

Shift Lock Control System

WIRING SYSTEM

48.Shift Lock Control System

A: WIRING DIAGRAM

1. WITHOUT PUSH BUTTON START

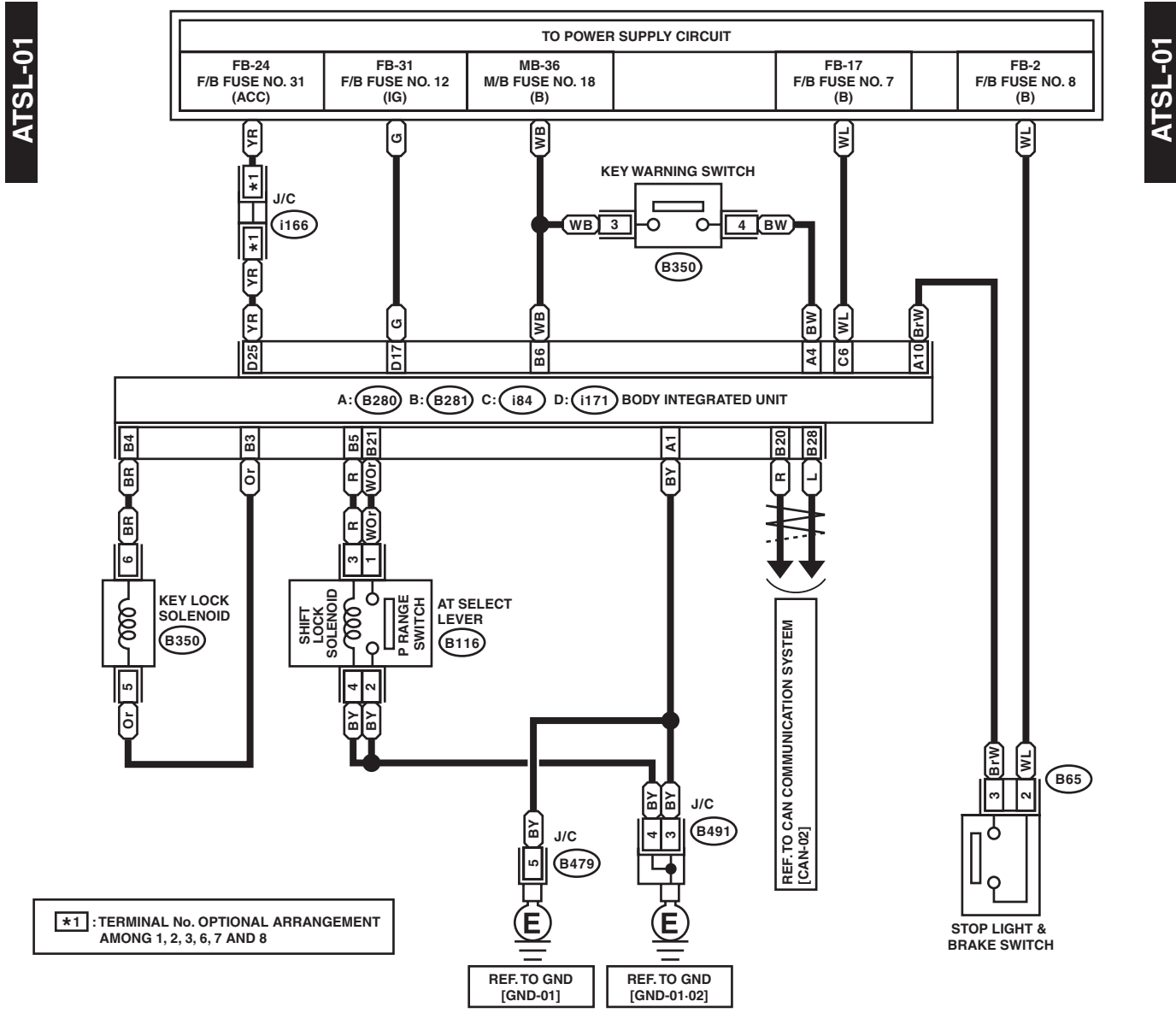

*1 : TERMINAL No. OPTIONAL ARRANGEMENT AMONG 1, 2, 3, 6, 7 AND 8

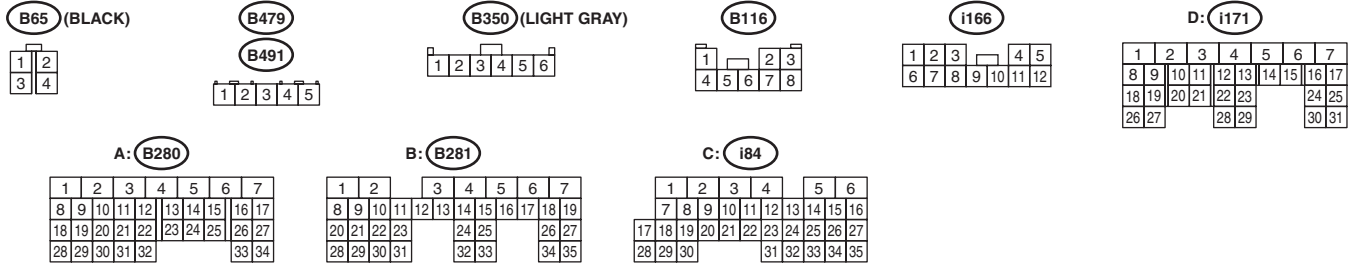

WI-41897

Shift Lock Control System

WIRING SYSTEM

2. WITH PUSH BUTTON START

ATSL(P)-01

ATSL(P)-01

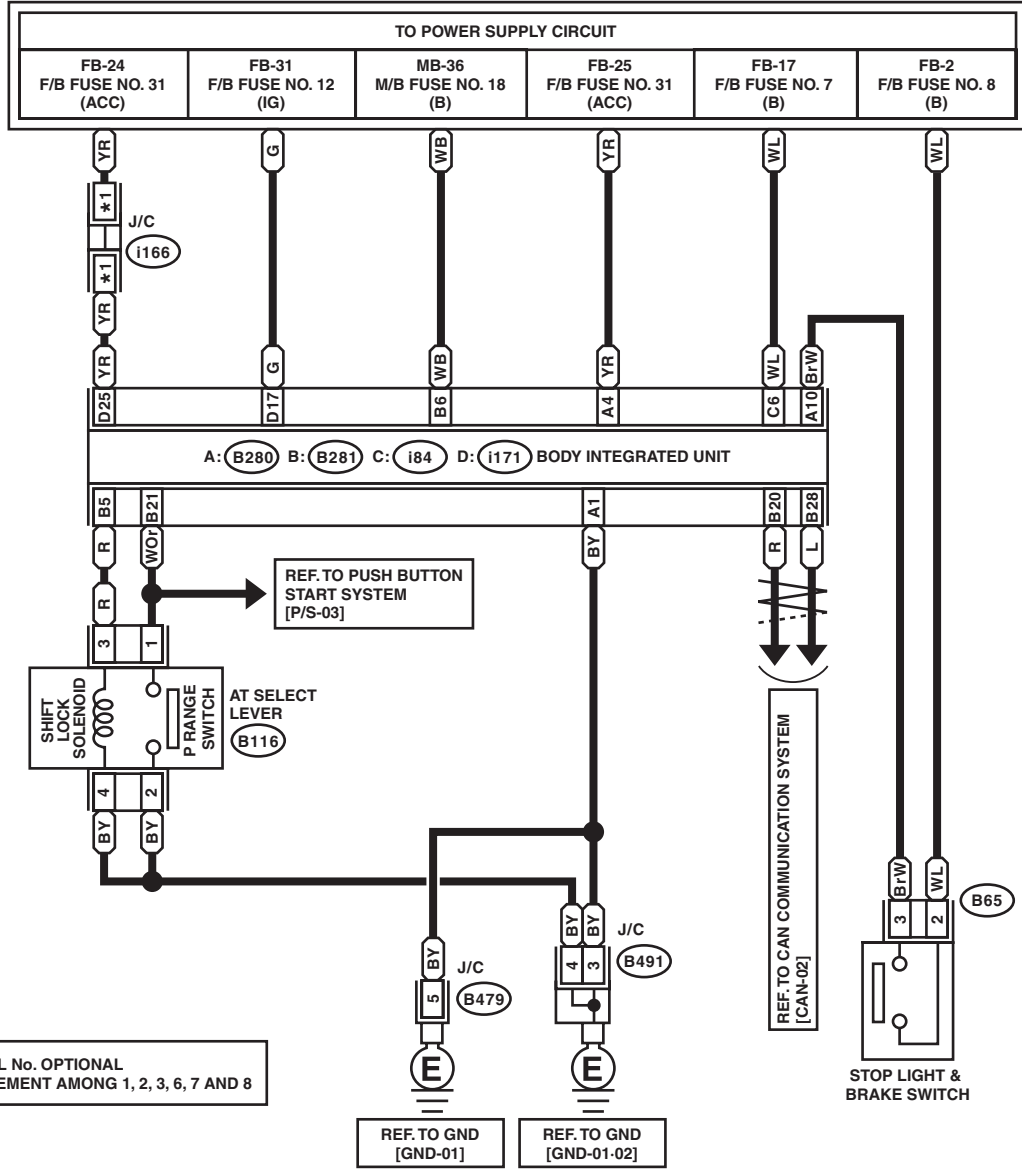

*1 : TERMINAL No. OPTIONAL ARRANGEMENT AMONG 1, 2, 3, 6, 7 AND 8

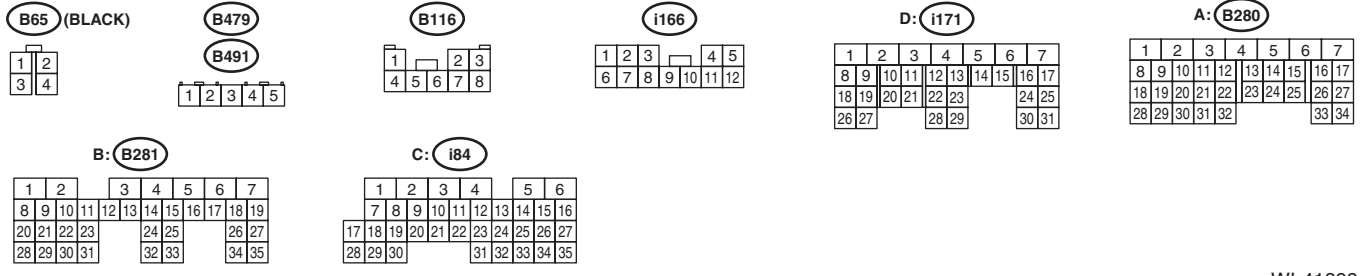

WI-41898