

General Description

AIRBAG SYSTEM (DIAGNOSTICS)

3. General Description

A: CAUTION

- When servicing a vehicle, be sure to turn the ignition switch to OFF, disconnect the ground cable from battery, and wait for more than 20 seconds before starting work.
- The airbag system is fitted with a backup power source. After disconnecting the battery ground cable, the airbag may deploy if you do not wait for more than 20 seconds before starting the service of airbag system.

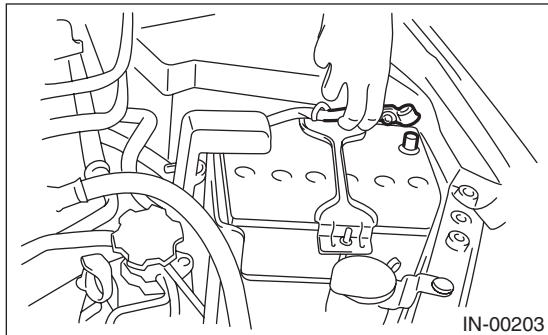

- If sensors, airbag module, airbag control module, pretensioner or harness is deformed or damaged, replace with new part.

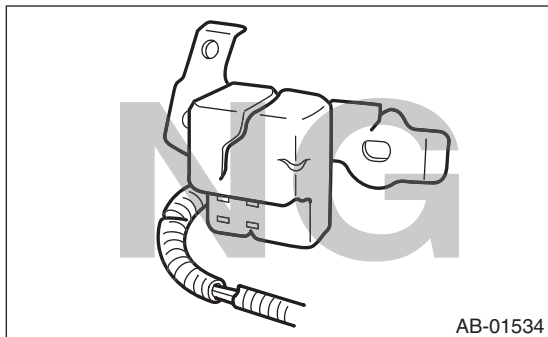

- Do not use the airbag system and pretensioners on other vehicles. When replacing parts, be sure to replace them with new parts.
- When inspecting the airbag system, be sure to use a digital circuit tester. Use of an analog circuit tester may cause the airbag to activate incorrectly due to a minimal current inside the tester.

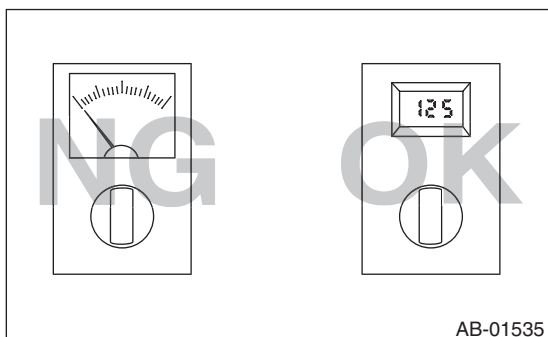

- When checking, use a test harness (1). Damage to connector terminal causes malfunction. Do not directly put the tester probe on airbag connector terminal.

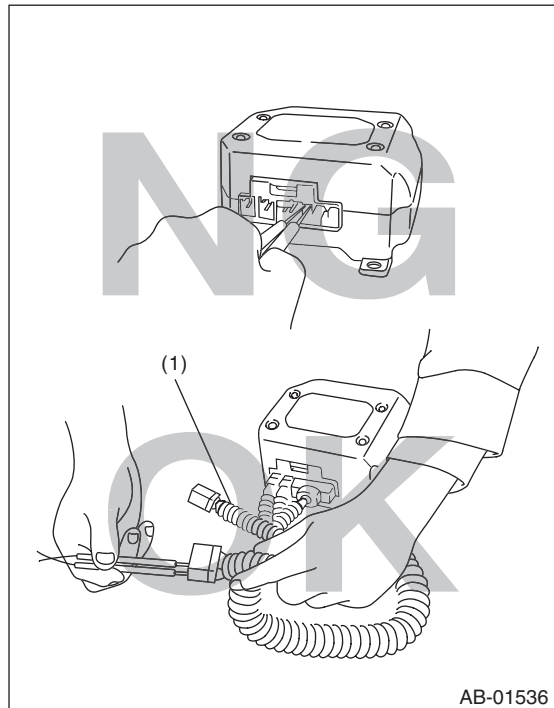

- Do not drop the airbag system parts, or keep them at high temperature over 93°C (199°F), or let water, oil or grease get on them; the internal parts may be damaged and reliability greatly lowered.

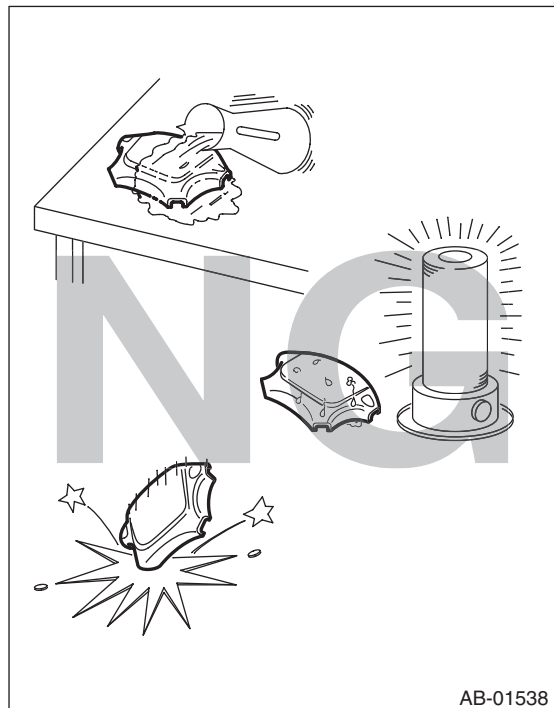

General Description

AIRBAG SYSTEM (DIAGNOSTICS)

- If damage, open circuit or rust is found on airbag system wiring harness, do not use a soldering equipment to repair. Replace the faulty harness with a new genuine part.

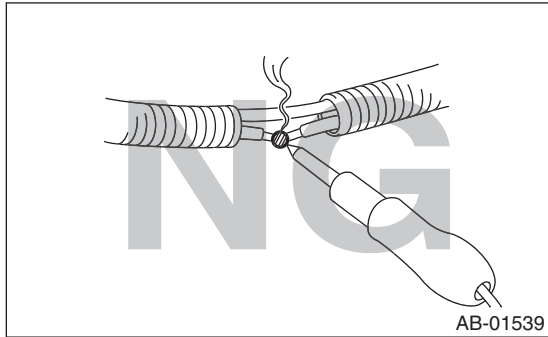

- Install the wiring harness securely with the specified clips to avoid interference or tangled with other parts.

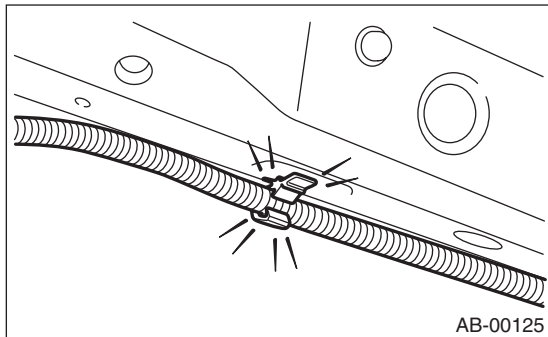

- Do not allow water or oil to come in contact with the connector terminals. Also do not touch the connector terminals.

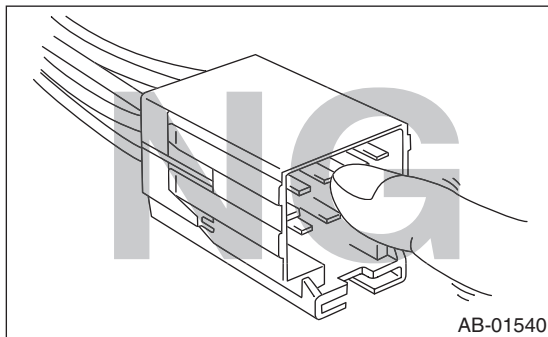

- Do not disassemble driver's airbag module, passenger's airbag module, side or curtain airbag modules, or pretensioner.

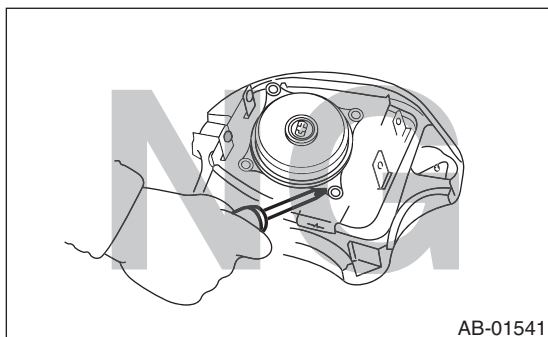

- The airbag module cannot be used again if deployed once.
- After removal, keep the airbag module with the pad side facing upward on a dry, clean and flat surface away from heat, light sources, moisture and dust.

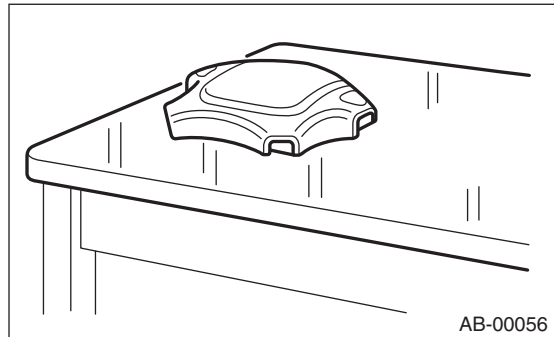

- Do not check continuity of the airbag modules for driver's side, passenger's side and curtain, or the pretensioner.

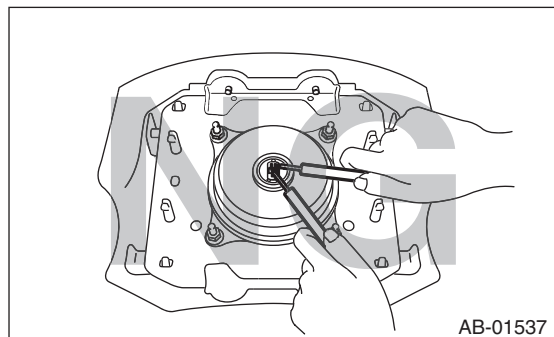

- The removed front seat with airbag module must be kept at least 200 mm (8 in) away from walls and other objects.

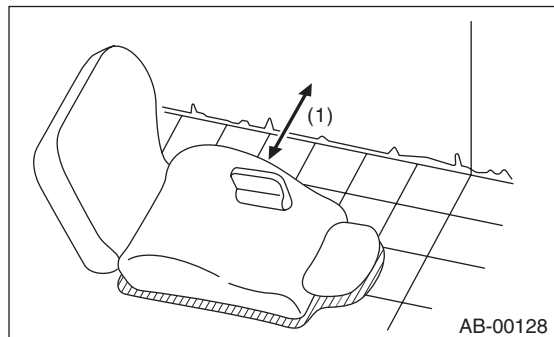

(1) 200 mm (8 in) or more

- When painting or performing sheet metal work on the front part of the vehicle, including the front wheel apron, front fender and front side frame, remove the front sub sensors and wiring harness of airbag system.

General Description

AIRBAG SYSTEM (DIAGNOSTICS)

- When painting or performing sheet metal work on the side of the vehicle, including the side sill, center pillar and front and rear doors, remove the side airbag sensors and wiring harness of the airbag system.

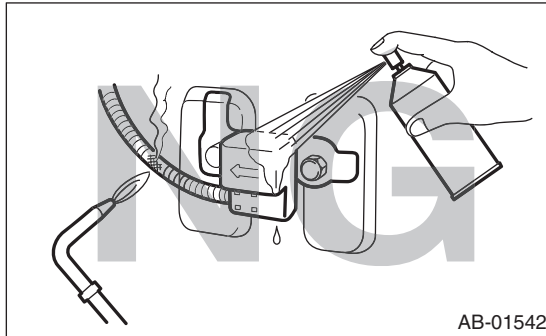

- Do not discard undeployed airbag module. They could easily cause a serious accident if accidentally deployed.

General Description

AIRBAG SYSTEM (DIAGNOSTICS)

- When storing a removed airbag module, do not place it with the pad side facing downward. Do not place any objects on the airbag module. Do not pile airbag modules on top of each other. If the airbag inflates for some reason when an airbag module pad is touching other objects, it may cause serious accident.

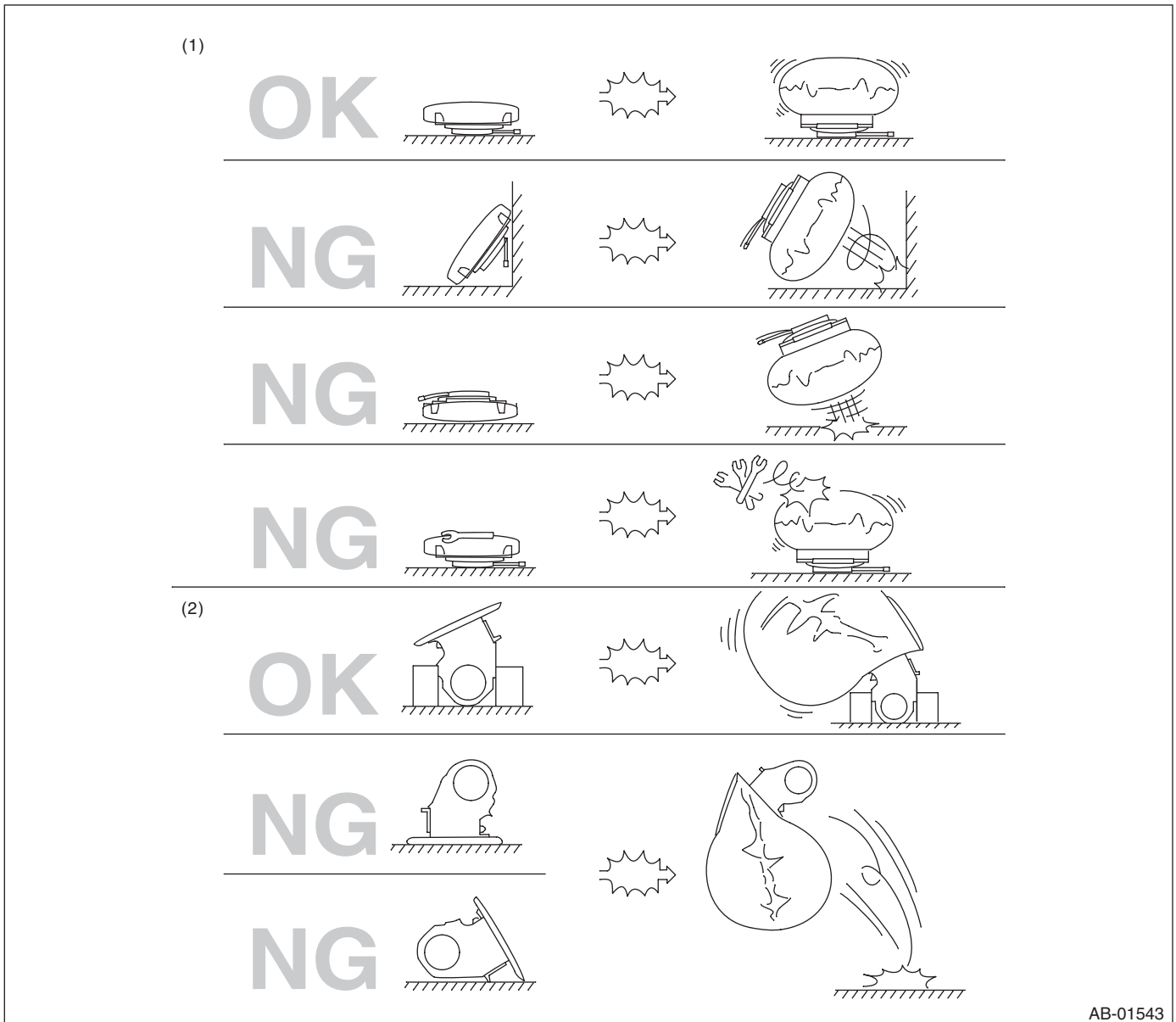

(1) Driver's airbag module

(2) Passenger's airbag module

General Description

AIRBAG SYSTEM (DIAGNOSTICS)

B: INSPECTION

Measure the battery voltage and check electrolyte.

Standard voltage: 12 V

Specific gravity: Above 1.260

C: PREPARATION TOOL

CAUTION:

To measure the voltage and resistance of airbag system component, be sure to use the specified test harness.

1. SPECIAL TOOL

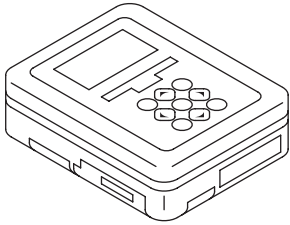
ILLUSTRATION	TOOL NUMBER	DESCRIPTION	REMARKS
 ST1B020XU0	1B020XU0	SUBARU SELECT MONITOR KIT	Used for troubleshooting the electrical system.

General Description

• TEST HARNESS D

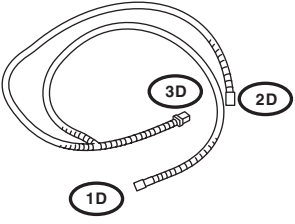
ILLUSTRATION	TOOL NUMBER	DESCRIPTION	REMARKS
 <p>ST98299AG060</p>	98299AG060	TEST HARNESS D	Used when measuring voltage and resistance of the front seat belt buckle switch.

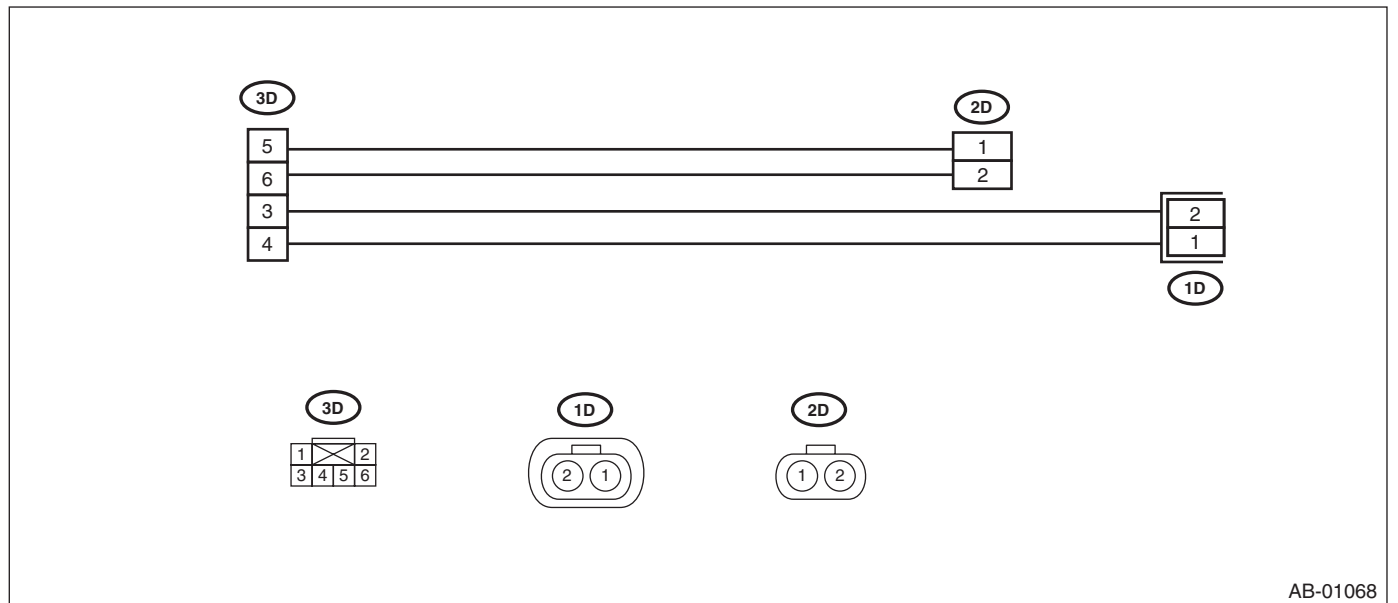

General Description

AIRBAG SYSTEM (DIAGNOSTICS)

- TEST HARNESS F

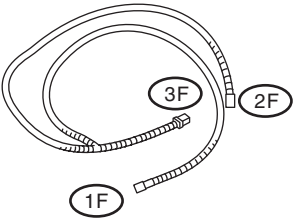
ILLUSTRATION	TOOL NUMBER	DESCRIPTION	REMARKS
 <p>ST98299FC010</p>	98299FC010	TEST HARNESS F	Used when measuring voltage and resistance of airbag module harnesses.

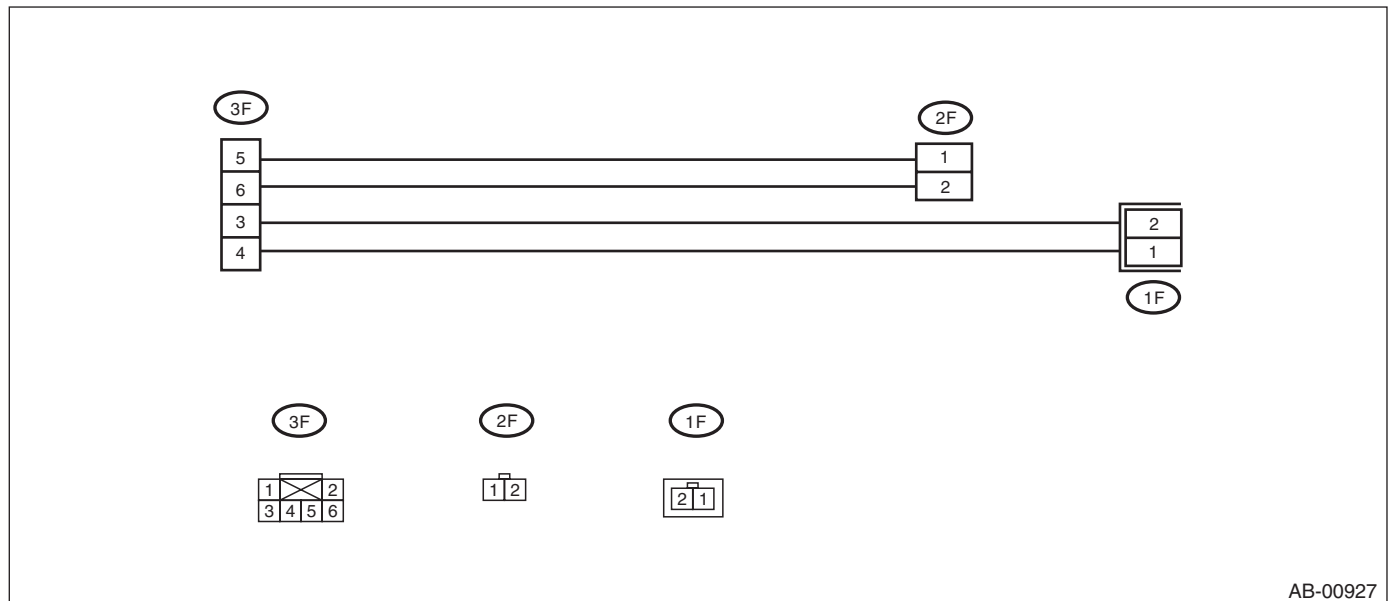

General Description

- TEST HARNESS H

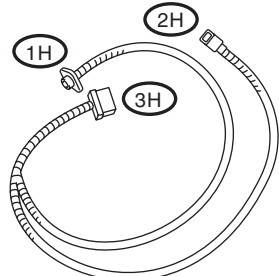
ILLUSTRATION	TOOL NUMBER	DESCRIPTION	REMARKS
 <p>ST98299FA030</p>	98299FA030	TEST HARNESS H	Used when measuring voltage and resistance of front sub sensor.

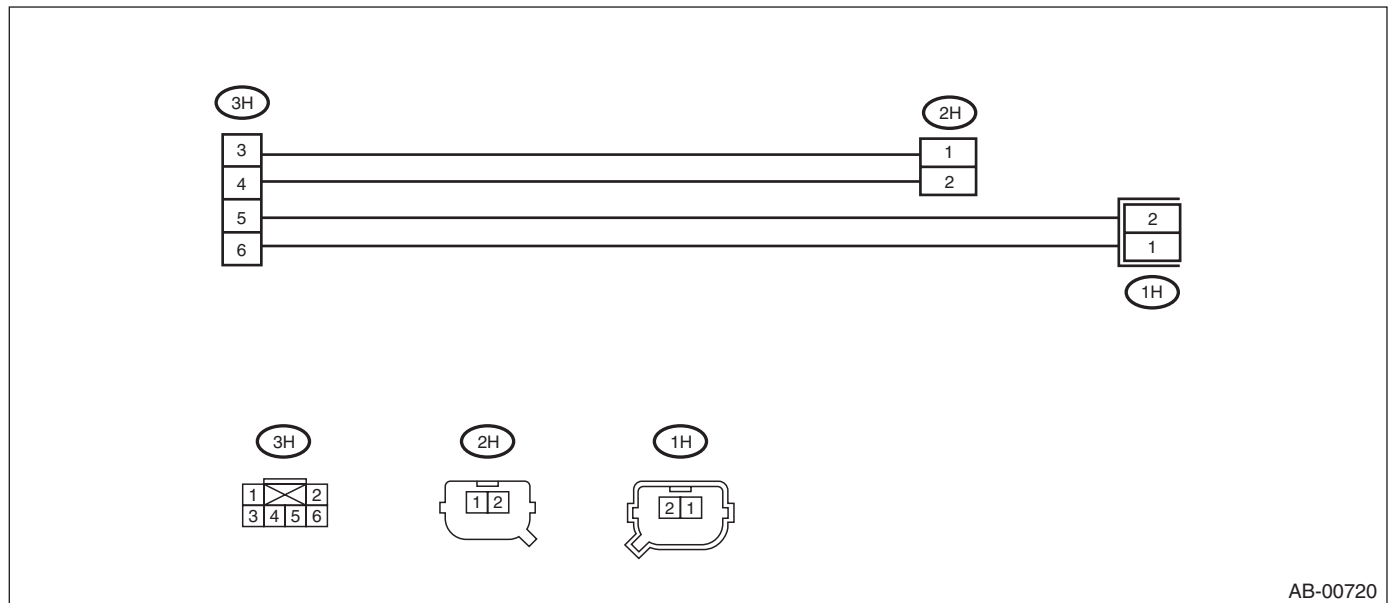

General Description

AIRBAG SYSTEM (DIAGNOSTICS)

- TEST HARNESS N

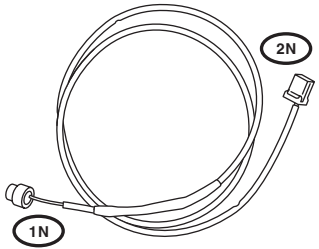
ILLUSTRATION	TOOL NUMBER	DESCRIPTION	REMARKS
 <p>ST98299SA000</p>	98299SA000	TEST HARNESS N	Used when measuring voltage and resistance of driver's airbag module, curtain airbag module and seat belt pretensioner.

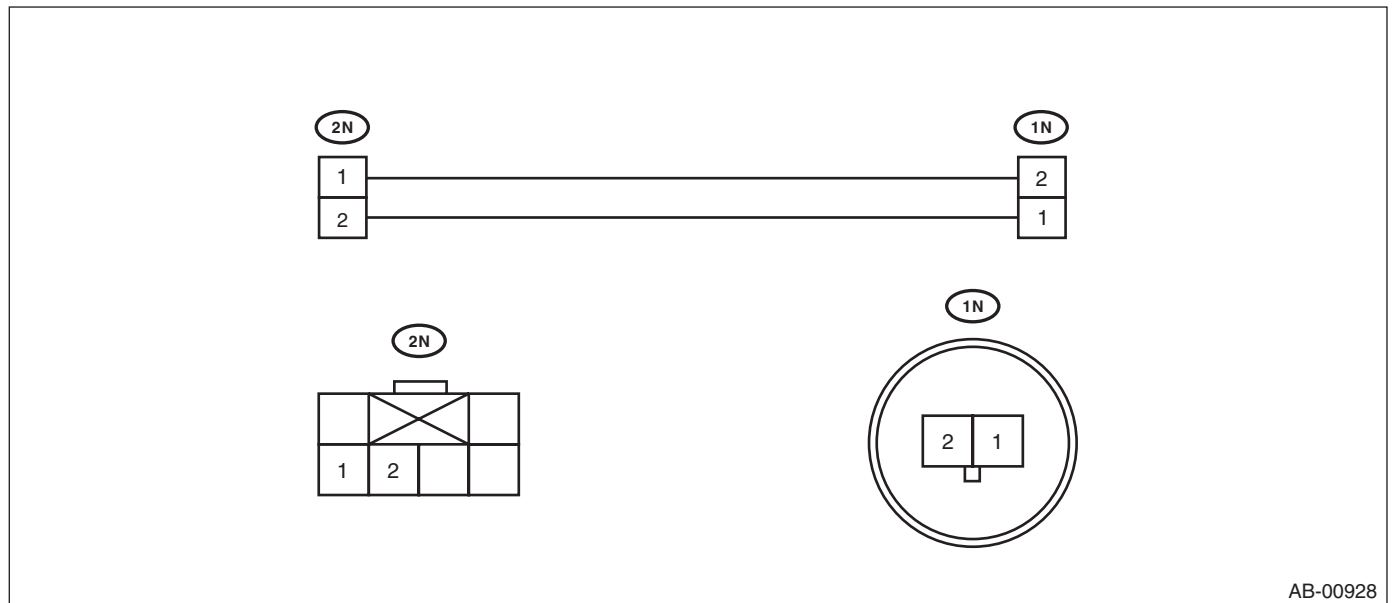

AB-00928

General Description

• TEST HARNESS P

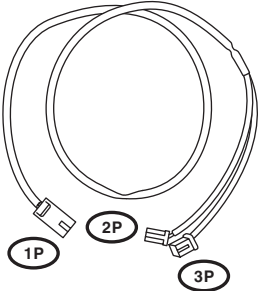
ILLUSTRATION	TOOL NUMBER	DESCRIPTION	REMARKS
 <p>ST98299SA020</p>	98299SA020	TEST HARNESS P	Used when measuring voltage and resistance of driver's airbag module harness and passenger's airbag module harness.

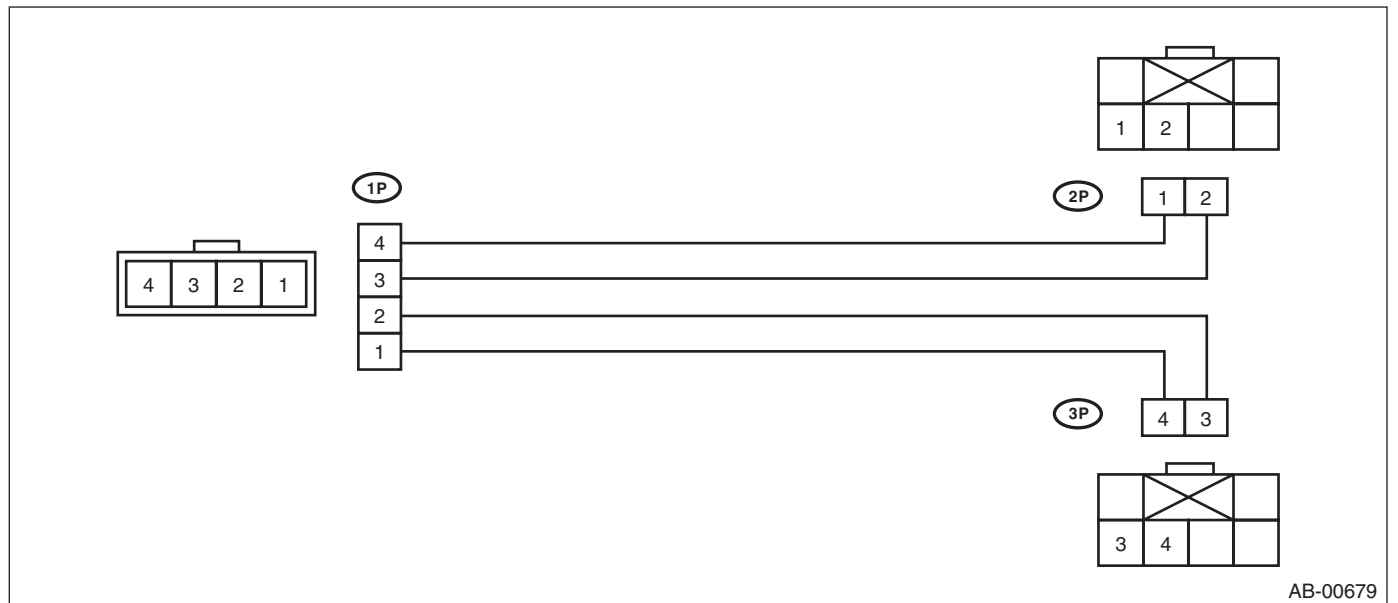

General Description

AIRBAG SYSTEM (DIAGNOSTICS)

- TEST HARNESS Q

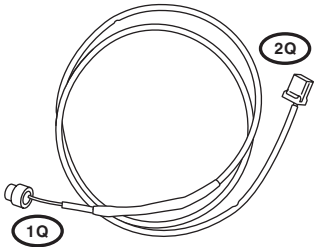
ILLUSTRATION	TOOL NUMBER	DESCRIPTION	REMARKS
 <p data-bbox="326 558 467 579">ST98299SA040</p>	98299SA040	TEST HARNESS Q	Used when measuring voltage and resistance of driver's airbag module.

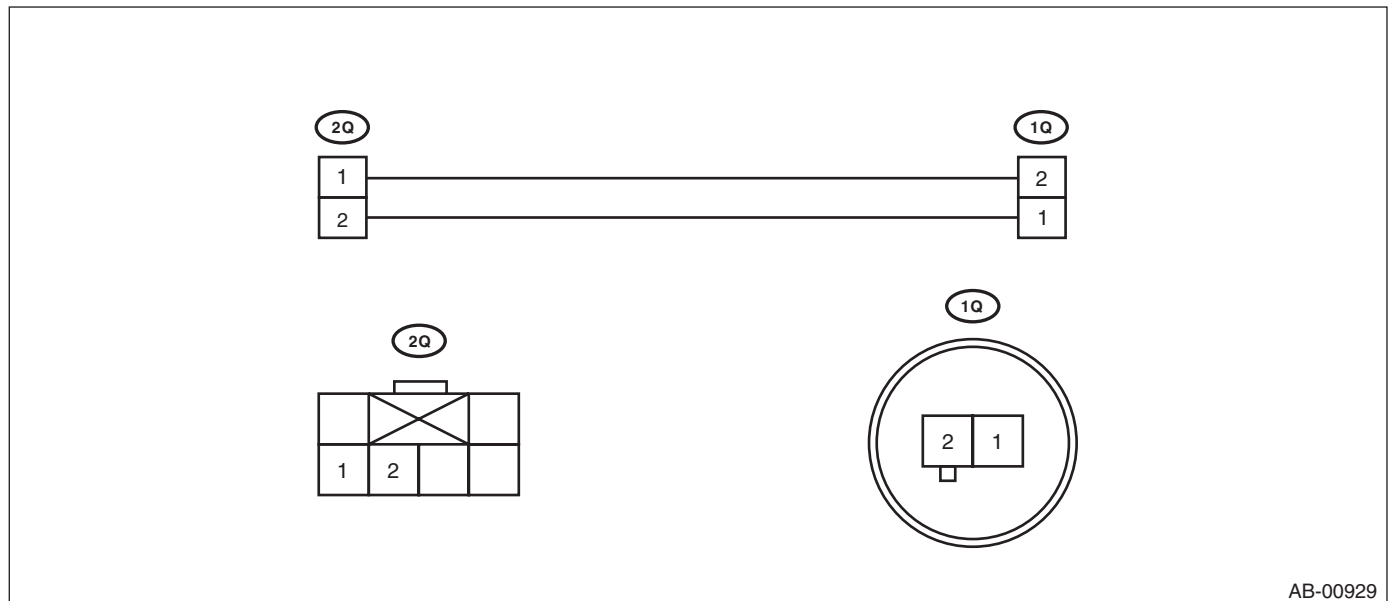

General Description

AIRBAG SYSTEM (DIAGNOSTICS)

- TEST HARNESS U

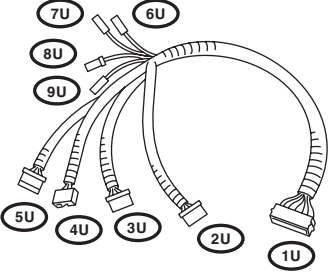
ILLUSTRATION	TOOL NUMBER	DESCRIPTION	REMARKS
 <p>The diagram shows a test harness with a central bundle of wires that splits into nine individual wires. Each wire is terminated with a specific connector. The wires are labeled as follows: 1U (bottom right), 2U (bottom center), 3U (bottom left), 4U (middle left), 5U (top left), 6U (top right), 7U (top left), 8U (middle left), and 9U (top left). The part number ST98299AG000 is printed at the bottom of the diagram.</p>	98299AG000	TEST HARNESS U	Used when measuring voltage and resistance of airbag control module.

General Description

AIRBAG SYSTEM (DIAGNOSTICS)

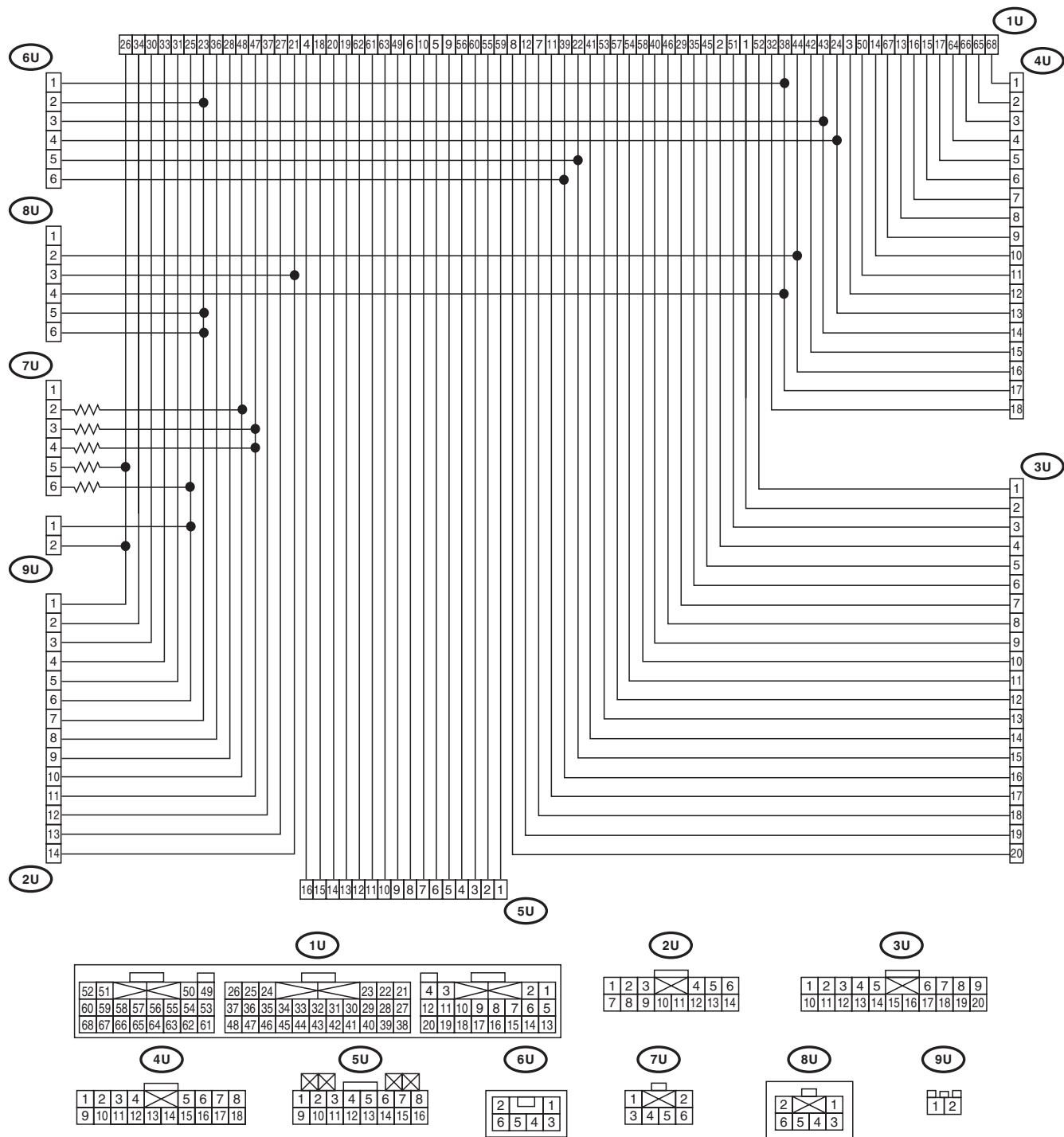

AB-00930

General Description

- TEST HARNESS V

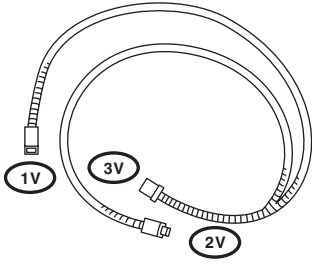
ILLUSTRATION	TOOL NUMBER	DESCRIPTION	REMARKS
 <p>ST98299AG010</p>	98299AG010	TEST HARNESS V	Used when measuring voltage and resistance of side airbag sensor and curtain airbag sensor.

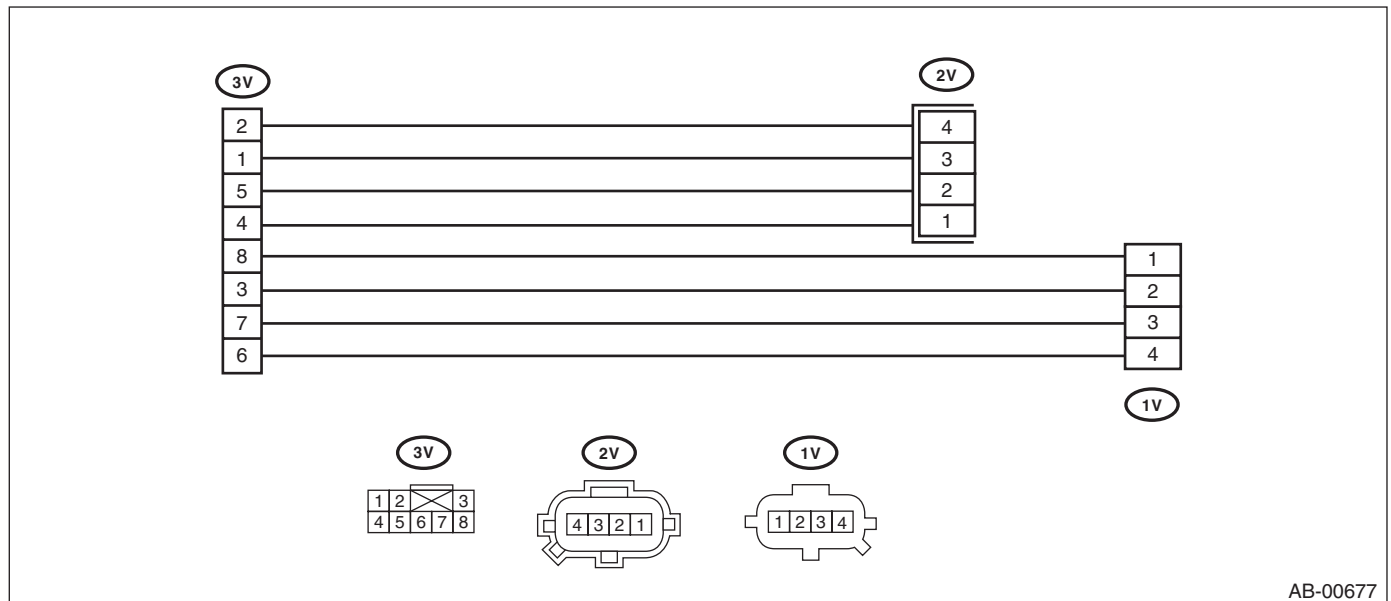

General Description

AIRBAG SYSTEM (DIAGNOSTICS)

- TEST HARNESS Y

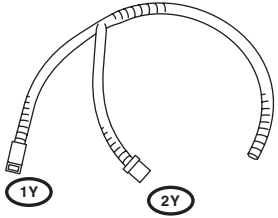
ILLUSTRATION	TOOL NUMBER	DESCRIPTION	REMARKS
 <p data-bbox="321 558 467 579">ST98299AG040</p>	98299AG040	TEST HARNESS Y	Used for diagnosing a failure of the seat belt buckle switch.

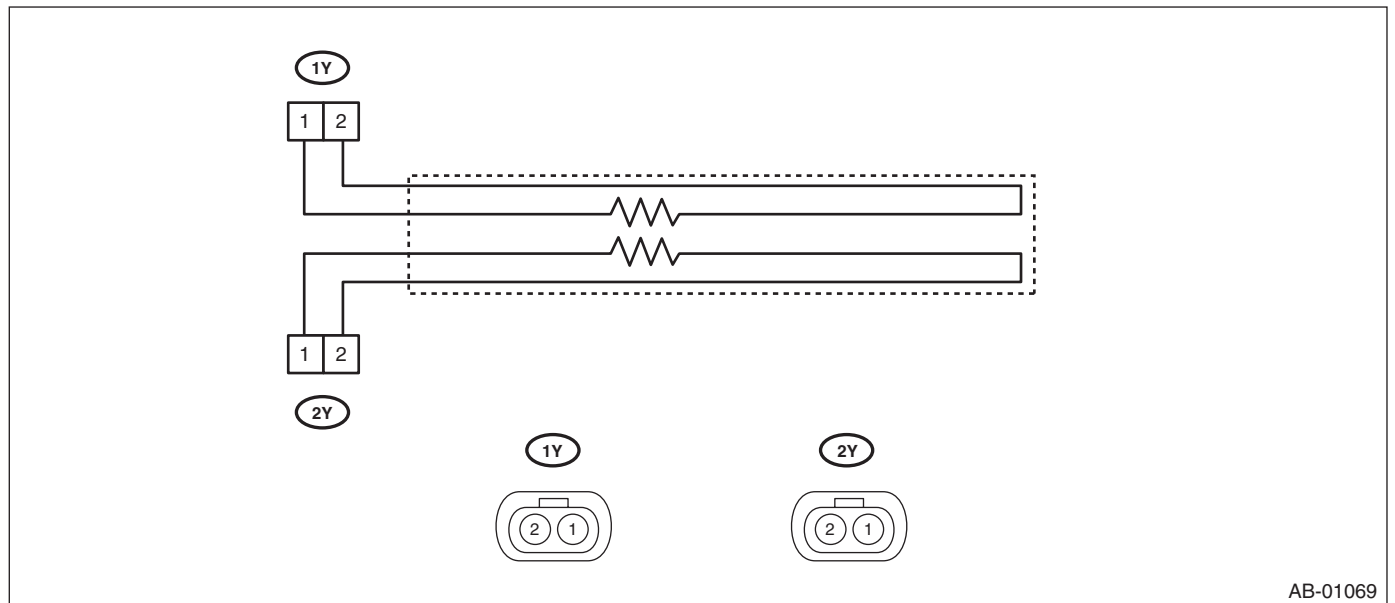

General Description

AIRBAG SYSTEM (DIAGNOSTICS)

- TEST HARNESS AB

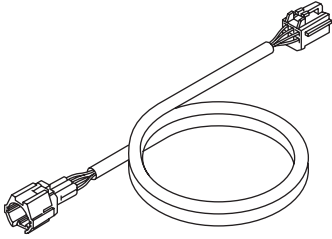
ILLUSTRATION	TOOL NUMBER	DESCRIPTION	REMARKS
 <p data-bbox="324 556 467 577">ST98299XA000</p>	98299XA000	TEST HARNESS AB	Used when measuring voltage and resistance of occupant detection system.

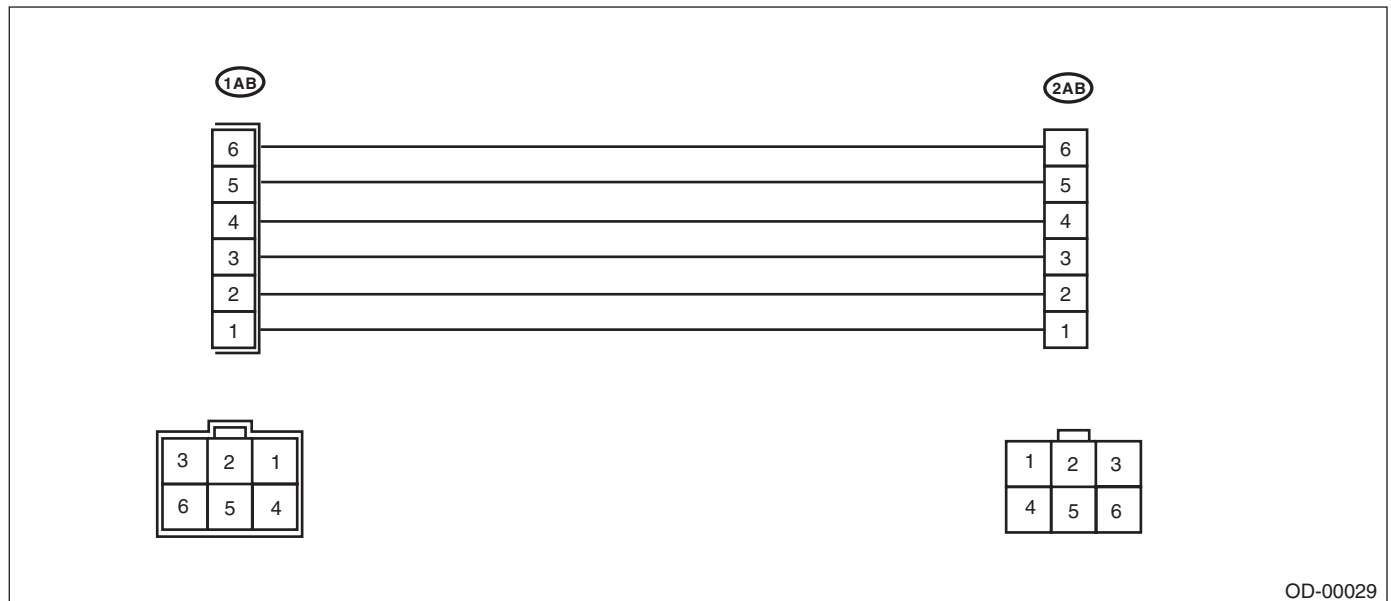

General Description

AIRBAG SYSTEM (DIAGNOSTICS)

- TEST HARNESS AC

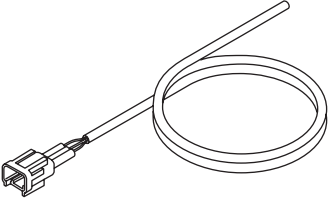
ILLUSTRATION	TOOL NUMBER	DESCRIPTION	REMARKS
 <p>ST98299XA010</p>	98299XA010	TEST HARNESS AC	Used for diagnosing a failure of the seat belt tension sensor.

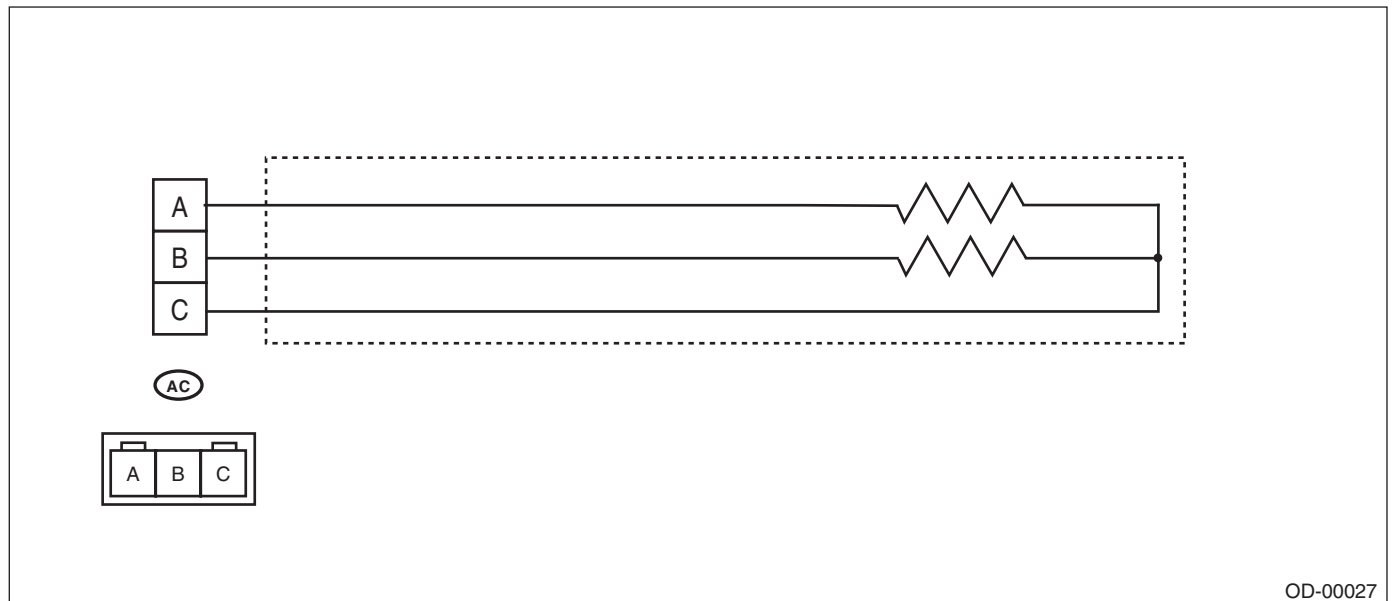

General Description

AIRBAG SYSTEM (DIAGNOSTICS)

- TEST HARNESS AD

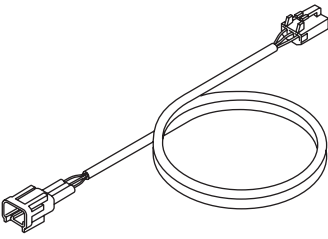
ILLUSTRATION	TOOL NUMBER	DESCRIPTION	REMARKS
 ST98299XA020	98299XA020	TEST HARNESS AD	Used when measuring voltage and resistance of seat belt tension sensor.

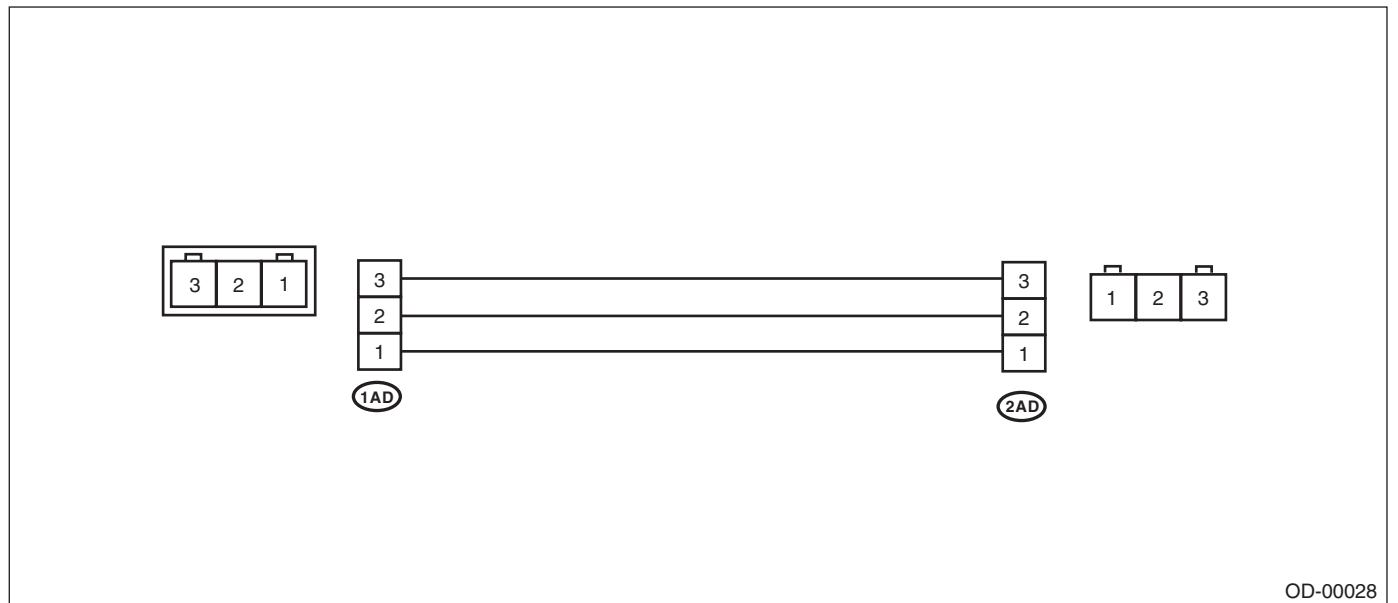

OD-00028

General Description

AIRBAG SYSTEM (DIAGNOSTICS)

• TEST HARNESS AE

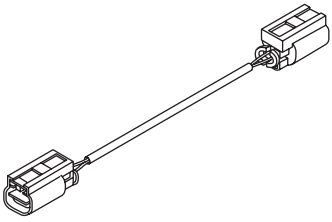
ILLUSTRATION	TOOL NUMBER	DESCRIPTION	REMARKS
 ST98299XA030	98299XA030	TEST HARNESS AE	<ul style="list-style-type: none">• Used for diagnosing a failure of the seat belt buckle switch.• Used together with the test harness Y.

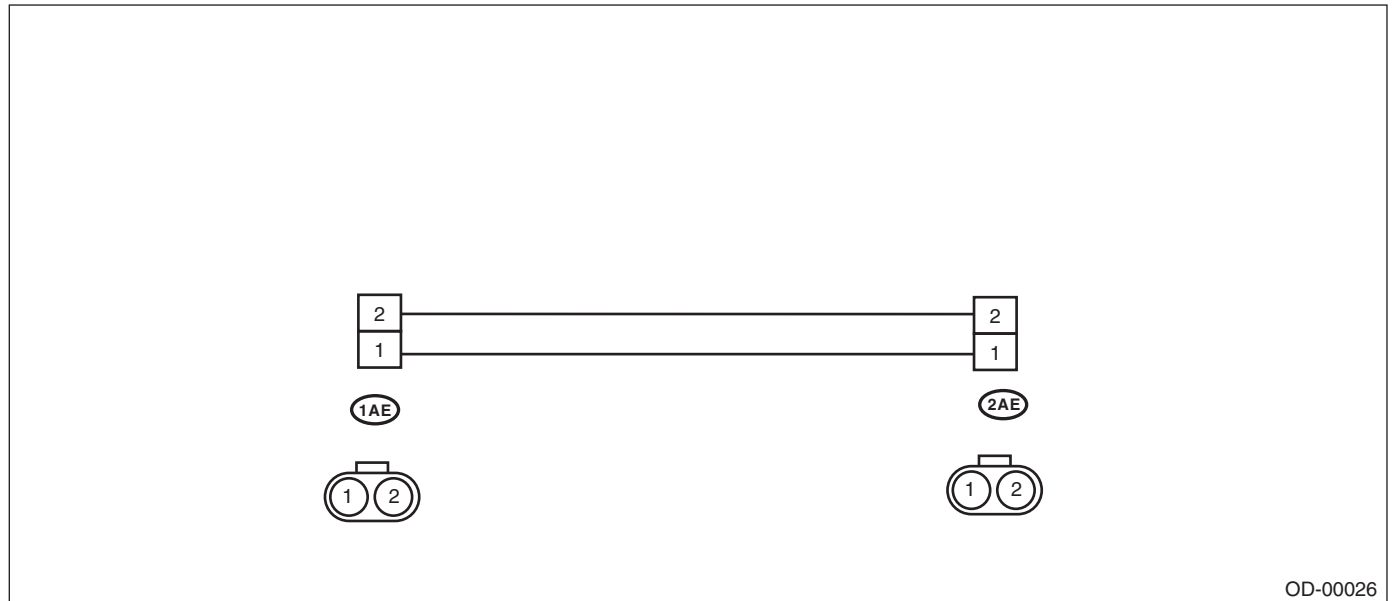

General Description

AIRBAG SYSTEM (DIAGNOSTICS)

• AIRBAG RESISTOR

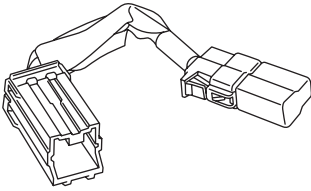
ILLUSTRATION	TOOL NUMBER	DESCRIPTION	REMARKS
 <p>ST98299PA040</p>	98299PA040	AIRBAG RESISTOR	Used in replacement of airbag module for which resistance value is same as airbag module.

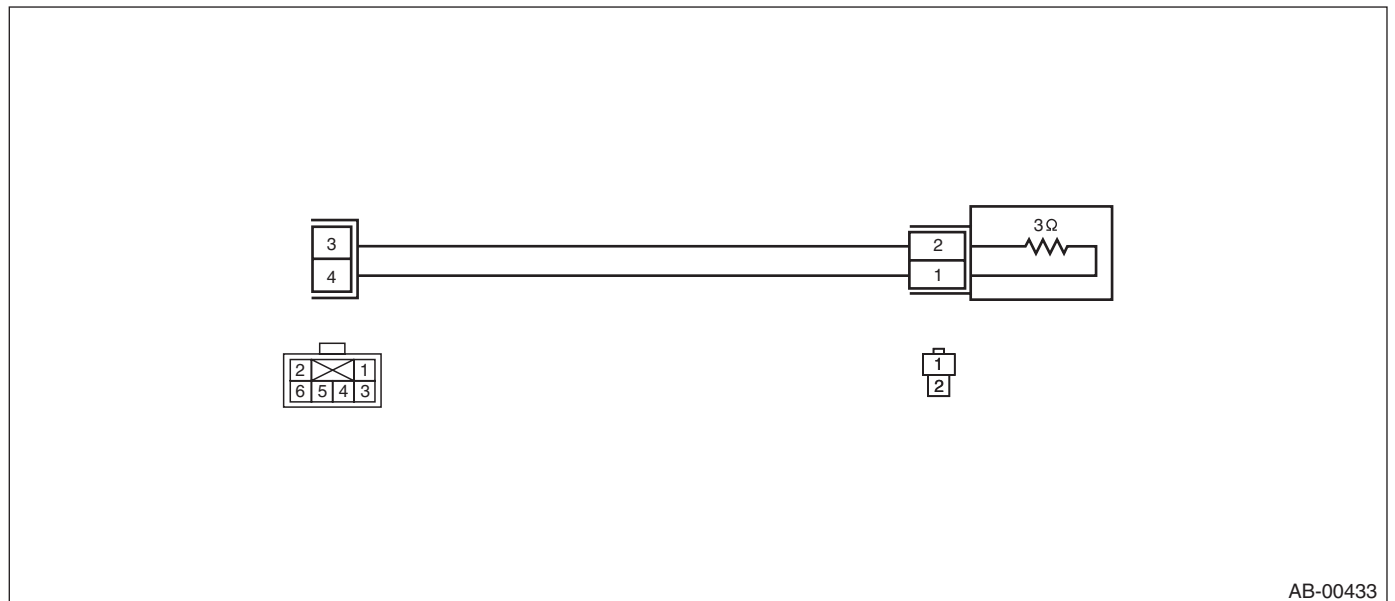

2. GENERAL TOOL

TOOL NAME	REMARKS
Circuit tester	Used for measuring resistance, voltage and current.
Oscilloscope	Used for measuring the sensor.