

5. Under Coat

A: SPECIFICATION



Repair material:

THREE BOND 6115

1) Take care that under coat does not attach to the locations other than shown in the figures and to the following locations.

- High-temperature parts related to the exhaust pipe
- Hoses, tubes, and harness parts
- Installation surfaces of rear suspension, transmission, subframe, etc.

2) Application area and application thickness

	300 μm or more
	600 μm or more
	

- Side view

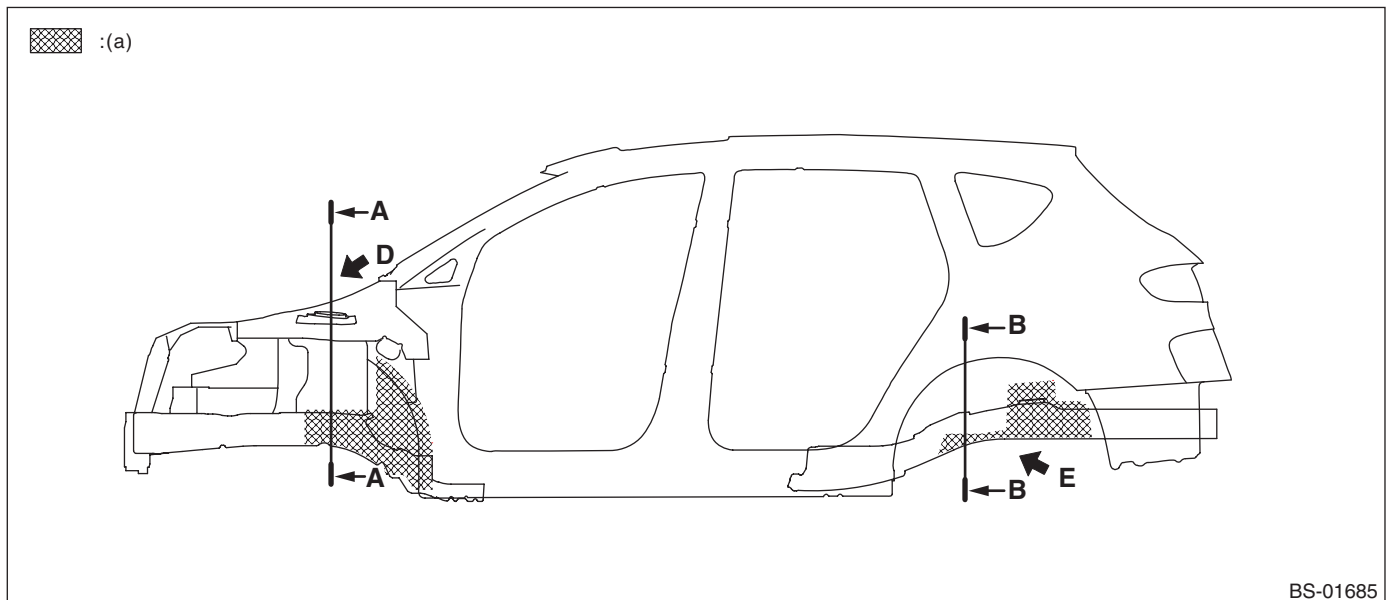

BS-01685

(a) 600 μm or more

Under Coat

BODY STRUCTURE

• Bottom view

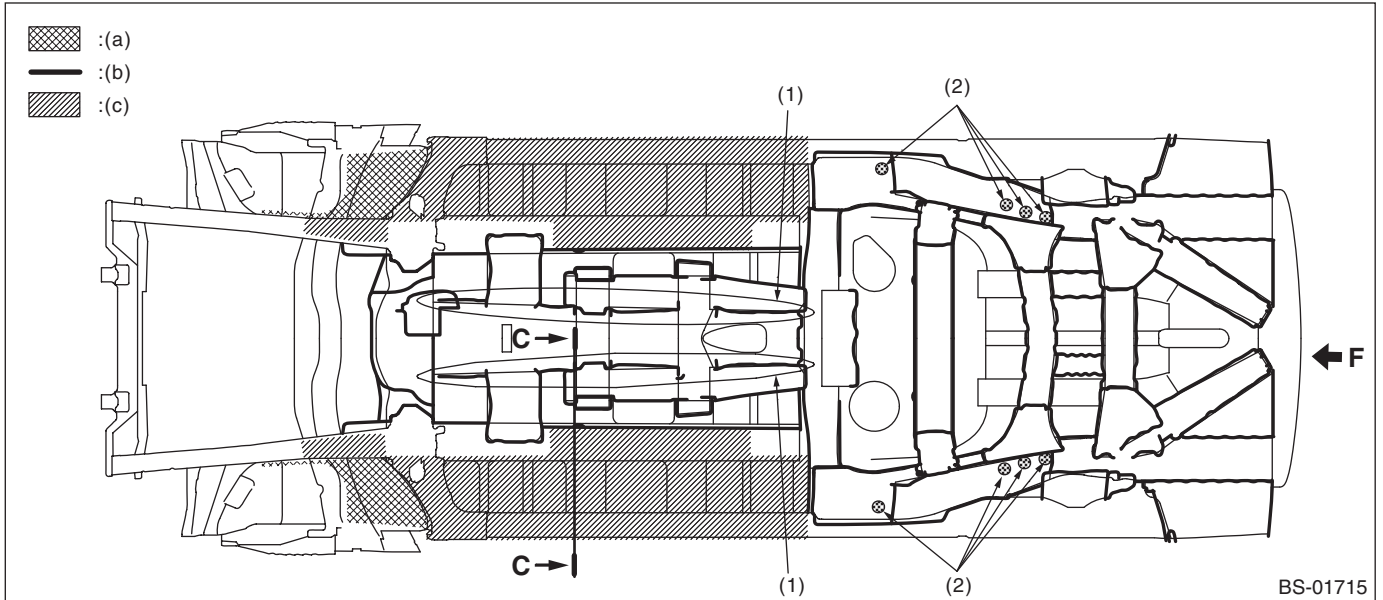

(a) 600 μm or more

(b) 600 μm or more

(c) 300 μm or more

(1) Film thickness in this area should be 200 μm or more.

(2) Apply to the grommet.

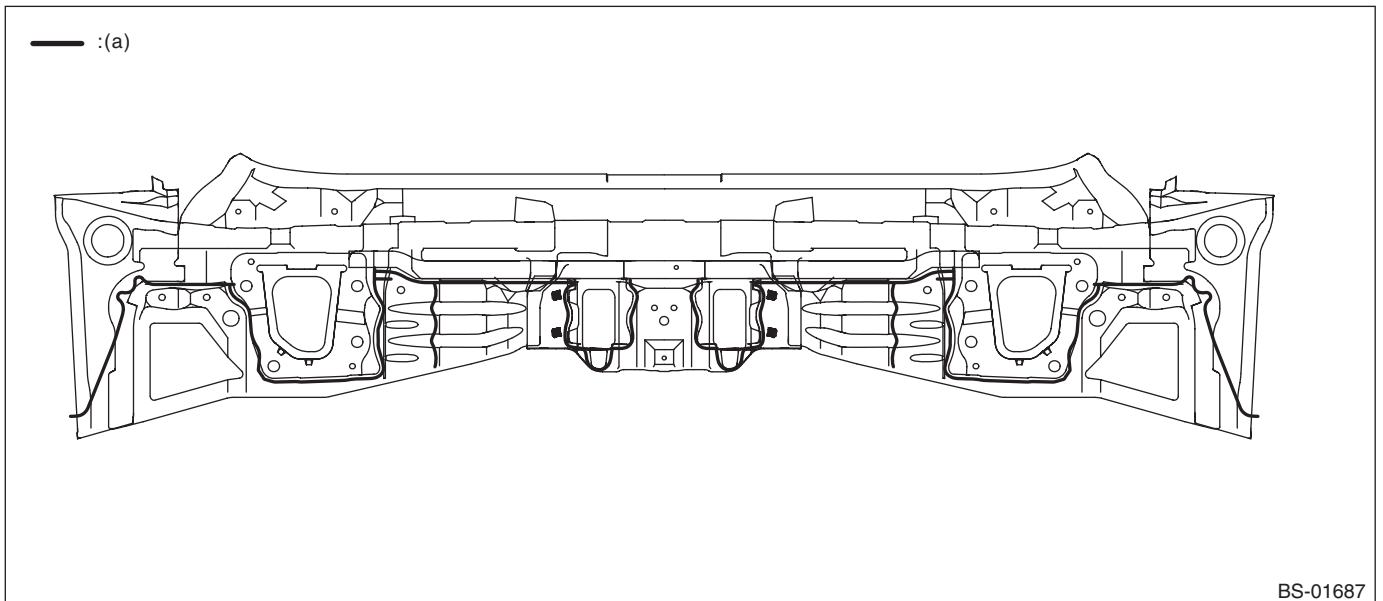

(a) 600 μm or more

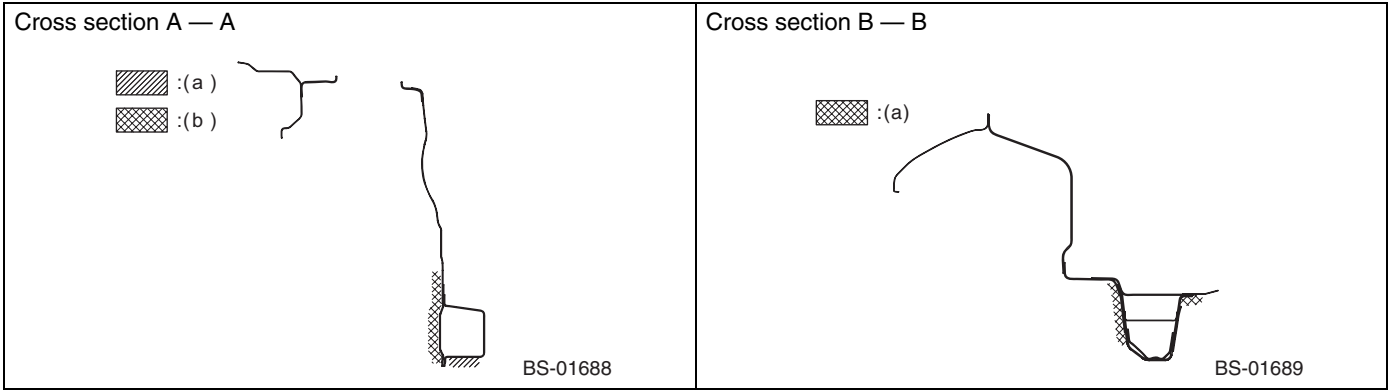

- (a) 300 μm or more
- (b) 600 μm or more

- (a) 600 μm or more

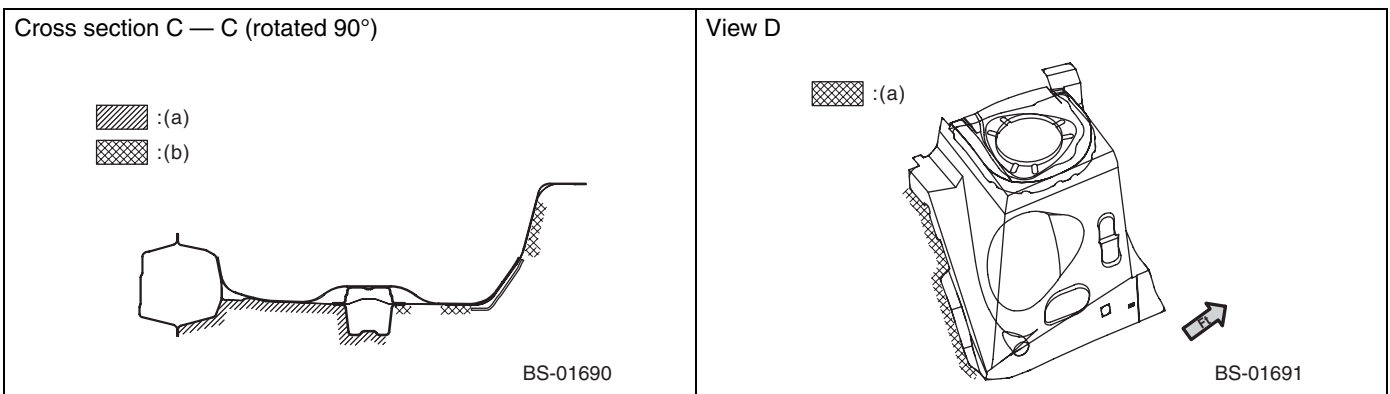

- (a) 300 μm or more
- (b) 600 μm or more

- (a) 600 μm or more

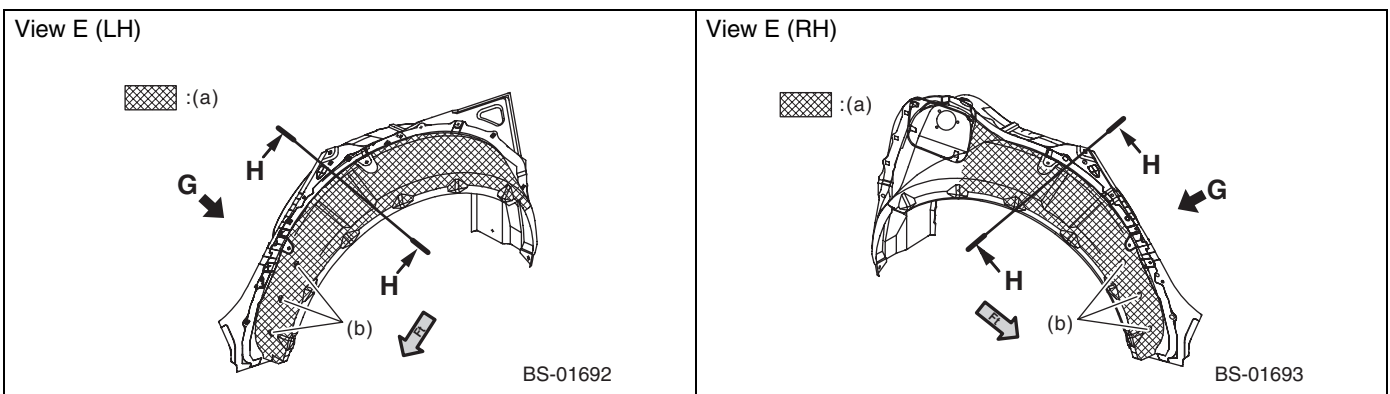



- (a) 600 μm or more
- (b) Also apply to the grommets.

- (a) 600 μm or more
- (b) Also apply to the grommets.

Under Coat

BODY STRUCTURE

View G (LH, RH)

-  : (a)
-  : (b)

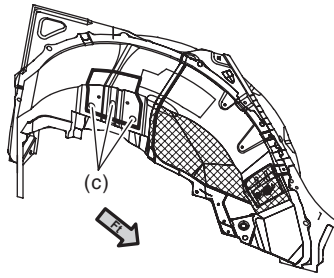

BS-01694

Cross section H — H

-  : (a)

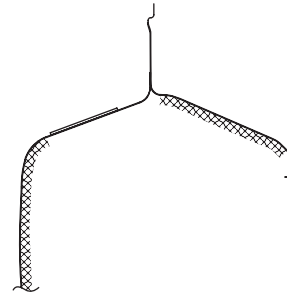

BS-01695

- (a) 600 μm or more
- (b) 600 μm or more
- (c) The holes shall be blocked.

- (a) 600 μm or more