

Diagnostic Procedure with Diagnostic Trouble Code (DTC)

CRUISE CONTROL SYSTEM (DIAGNOSTICS)

8. Diagnostic Procedure with Diagnostic Trouble Code (DTC)

A: DTC 11

TROUBLE SYMPTOM:

- Cruise control cannot be set. (Cancelled immediately.)
- Cruise control cannot be released.

WIRING DIAGRAM:

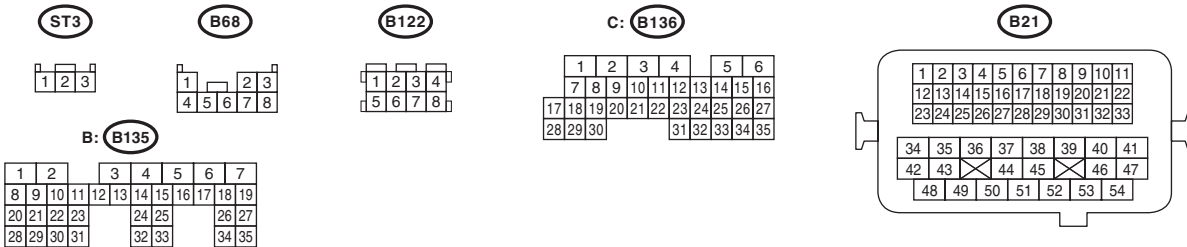
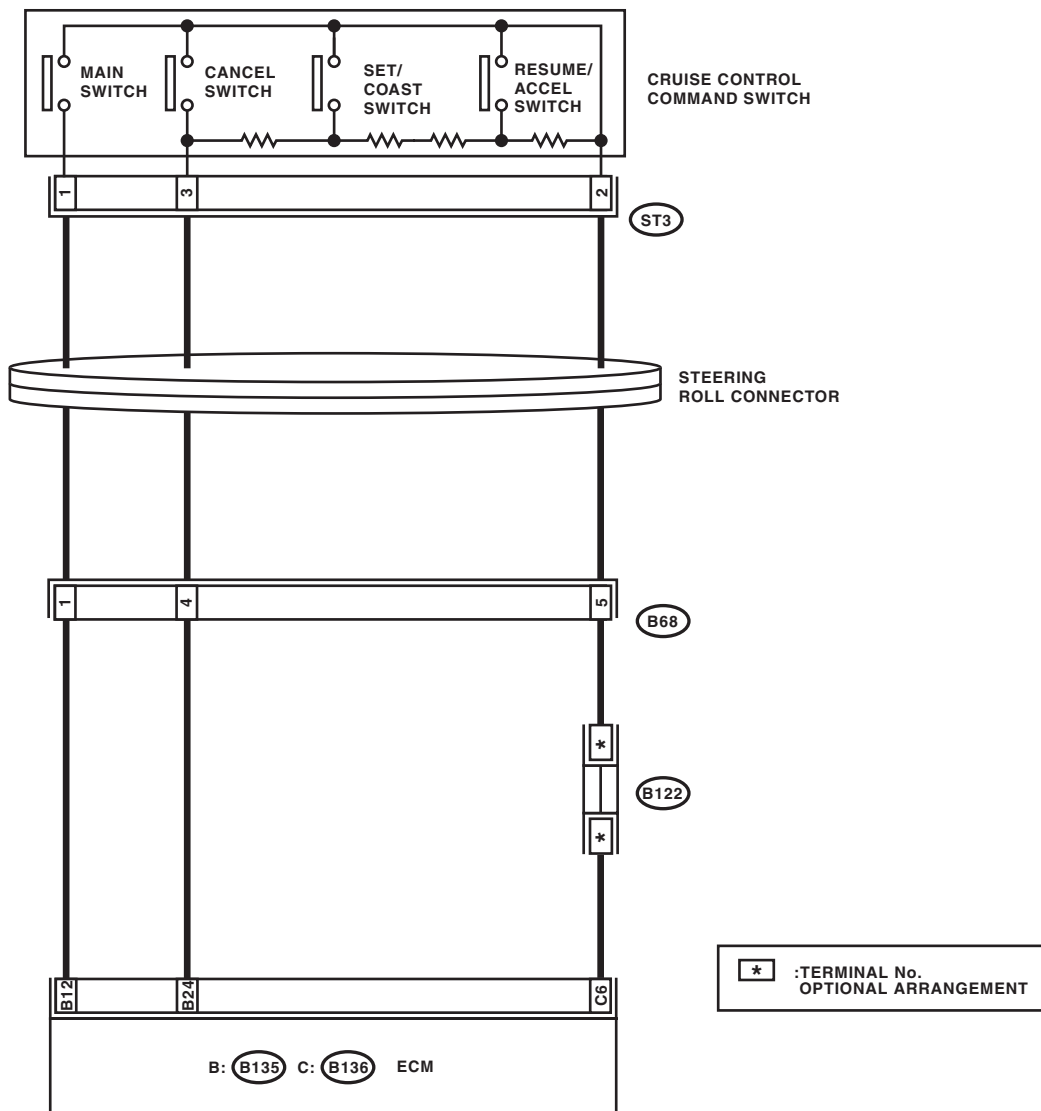

CC-00371

Diagnostic Procedure with Diagnostic Trouble Code (DTC)

CRUISE CONTROL SYSTEM (DIAGNOSTICS)

Step	Check	Yes	No
<p>1 CHECK CRUISE CONTROL COMMAND SWITCH CIRCUIT.</p> <p>1) Remove the driver's airbag module. <Ref. to AB-14, REMOVAL, Driver's Airbag Module.></p> <p>2) Disconnect the harness connector of cruise control command switch.</p> <p>3) Turn the ignition switch to ON.</p> <p>4) Measure the voltage between harness connector terminal and chassis ground.</p> <p>Connector & terminal (ST3) No. 1 (+) — Chassis ground (-): (ST3) No. 3 (+) — Chassis ground (-):</p>	Is the voltage 5 V or more?	Go to step 2.	Check the harness between cruise control command switch and ECM, and the steering roll connector for open or short circuit, or for poor contact.
<p>2 CHECK CRUISE CONTROL COMMAND SWITCH CIRCUIT.</p> <p>1) Turn the ignition switch to OFF.</p> <p>2) Remove the cruise control command switch. <Ref. to CC-5, REMOVAL, Cruise Control Command Switch.></p> <p>3) Measure the resistance between harness connector terminal and chassis ground.</p> <p>Connector terminal (ST3) No. 2 — Chassis ground:</p>	Is the resistance less than 10 Ω ?	Go to step 3.	Check for open between cruise control command switch and ECM and chassis ground, and check the ECM.
<p>3 Check Cruise Control Command Switch</p> <p>Measure the resistance between switch terminals when the cruise control command switch is not being pressed.</p> <p>Terminals No. 2 — No. 3:</p>	Is the resistance approx. 4 k Ω ?	Go to step 4.	Replace the cruise control command switch. <Ref. to CC-5, Cruise Control Command Switch.>
<p>4 CHECK CANCEL SWITCH.</p> <p>1) Turn the ignition switch to OFF.</p> <p>2) Remove the cruise control command switch. <Ref. to CC-5, REMOVAL, Cruise Control Command Switch.></p> <p>3) Measure the resistance between switch terminals when the CANCEL switch is pressed.</p> <p>Terminals No. 2 — No. 3:</p>	Is the resistance approx. less than 1 Ω when the CANCEL switch is pressed?	Go to step 5.	Replace the cruise control command switch. <Ref. to CC-5, Cruise Control Command Switch.>
<p>5 CHECK SET/COAST SWITCH.</p> <p>Measure the resistance between switch terminals when the SET/COAST switch is pressed.</p> <p>Terminals No. 2 — No. 3:</p>	Is the resistance approx. 250 Ω when SET/COAST switch is pressed?	Go to step 6.	Replace the cruise control command switch. <Ref. to CC-5, Cruise Control Command Switch.>
<p>6 CHECK RESUME/ACCEL SWITCH CIRCUIT.</p> <p>Measure the resistance between switch terminals when the RESUME/ACCEL switch is pressed.</p> <p>Terminals No. 2 — No. 3:</p>	Is the resistance approx. 1,500 Ω when RESUME/ACCEL switch is pressed?	Replace the ECM. <Ref. to FU(H6DO)-33, Engine Control Module (ECM).>	Replace the cruise control command switch. <Ref. to CC-5, Cruise Control Command Switch.>

Diagnostic Procedure with Diagnostic Trouble Code (DTC)

CRUISE CONTROL SYSTEM (DIAGNOSTICS)

B: DTC 12

TROUBLE SYMPTOM:

- Cruise control cannot be set.
- Cruise control cannot be released.

WIRING DIAGRAM:

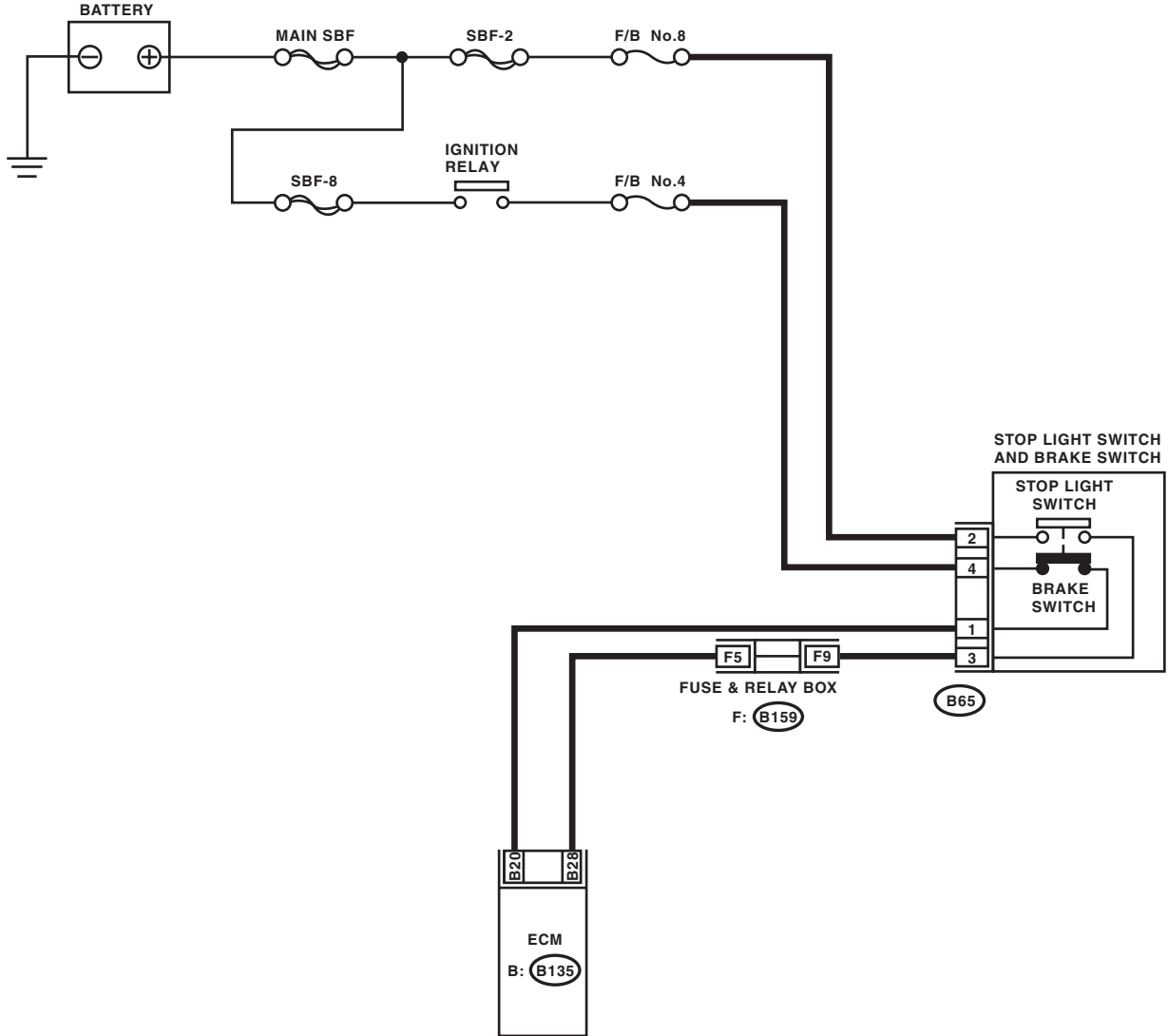

B107



B65



F: B159

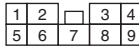

B: B135

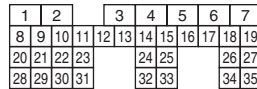

CC-00372

Diagnostic Procedure with Diagnostic Trouble Code (DTC)

CRUISE CONTROL SYSTEM (DIAGNOSTICS)

Step	Check	Yes	No
1 CHECK STOP LIGHT SWITCH AND BRAKE SWITCH CIRCUIT. 1) Turn the ignition switch to OFF. 2) Disconnect the stop light switch and brake switch harness connector. 3) Turn the ignition switch to ON. 4) Measure the voltage between harness connector terminal and chassis ground. Connector & terminal (B65) No. 2 (+) — Chassis ground (-):	Is the voltage 10 V or more?	Go to step 2.	<ul style="list-style-type: none"> • Check fuse No. 8 (in fuse & relay box). • Check for open or short in the harness between stop light/brake switch and fuse & relay box.
2 CHECK STOP LIGHT SWITCH AND BRAKE SWITCH CIRCUIT. Measure the voltage between harness connector terminal and chassis ground. Connector & terminal (B65) No. 4 (+) — Chassis ground (-):	Is the voltage 10 V or more?	Go to step 3.	<ul style="list-style-type: none"> • Check fuse No. 4 (in fuse & relay box). • Check for open or short in the harness between stop light/brake switch and fuse & relay box.
3 CHECK STOP LIGHT SWITCH AND BRAKE SWITCH CIRCUIT. 1) Turn the ignition switch to OFF. 2) Disconnect the harness connector of ECM. 3) Measure the resistance between ECM harness connector terminal and stop light switch and brake switch harness connector terminal. Connector & terminal (B135) No. 28 — (B65) No. 3: (B135) No. 20 — (B65) No. 1:	Is the resistance less than 10 Ω ?	Go to step 4.	Repair the harness.
4 Check Stop Light Switch and Brake Switch Remove and check the stop light switch and brake switch. <Ref. to CC-6, Stop Light & Brake Switch.>	Are the stop light switch and brake switch OK?	Replace the ECM. <Ref. to FU(H6DO)-33, Engine Control Module (ECM).>	Replace the stop light switch and brake switch.

Diagnostic Procedure with Diagnostic Trouble Code (DTC)

CRUISE CONTROL SYSTEM (DIAGNOSTICS)

C: DTC 14

TROUBLE SYMPTOM:

Cruise control cannot be set.

WIRING DIAGRAM:



B: **B55**

1	2	3	4	5	6	7	8	9
10	11	12	13	14	15	16	17	18
19	20	21				22	23	24

C: **B136**

1	2	3	4	5	6					
7	8	9	10	11	12	13	14	15	16	
17	18	19	20	21	22	23	24	25	26	27
28	29	30				31	32	33	34	35

CC-00373

Diagnostic Procedure with Diagnostic Trouble Code (DTC)

CRUISE CONTROL SYSTEM (DIAGNOSTICS)

	Step	Check	Yes	No
1	CHECK NEUTRAL POSITION SWITCH. 1) Connect the Subaru Select Monitor to data link connector. 2) Turn the ignition switch to ON and run the Subaru Select Monitor. 3) Select {Engine Control System} from the main menu. 4) Then, select {Current Data Display & Save}. 5) Check the neutral position switch signal by shifting the select lever to "P" or "N" range.	Is Subaru Select Monitor ON when select lever is shifted into "P" or "N" range? Is Subaru Select Monitor OFF when select lever is shifted to a range other than the "P" or "N" range?	Replace the ECM. <Ref. to FU(H6DO)-33, Engine Control Module (ECM).>	Go to step 2.
2	CHECK TCM OUTPUT VOLTAGE. 1) Turn the ignition switch to ON. 2) Measure the voltage between TCM harness connector terminal and chassis ground. Connector & terminal (B55) No. 19 (+) — Chassis ground (-):	Is voltage more than 10 V when select lever is shifted to a range other than "P" or "N" range? Is voltage less than 1 V when select lever is shifted into "P" or "N" range?	Go to step 3.	Check the TCM. <Ref. to 5AT(diag)-2, Basic Diagnostic Procedure.>
3	CHECK HARNESS BETWEEN TCM AND ECM. 1) Turn the ignition switch to OFF. 2) Disconnect the harness connector from TCM and ECM. 3) Measure the resistance between TCM harness connector terminal and ECM harness connector terminal. Connector & terminal (B136) No. 31 — (B55) No. 19:	Is the resistance less than 10 Ω ?	Replace the ECM. <Ref. to FU(H6DO)-33, Engine Control Module (ECM).>	Repair the wiring harness.

D: DTC 15

Malfunction regarding the cancel switch.

Refer to DTC 11 for diagnostic procedure.

<Ref. to CC(diag)-15, DTC 11, Diagnostic Procedure with Diagnostic Trouble Code (DTC).>

Diagnostic Procedure with Diagnostic Trouble Code (DTC)

CRUISE CONTROL SYSTEM (DIAGNOSTICS)

E: DTC 16

TROUBLE SYMPTOM:

Cruise control cannot be set.

WIRING DIAGRAM:

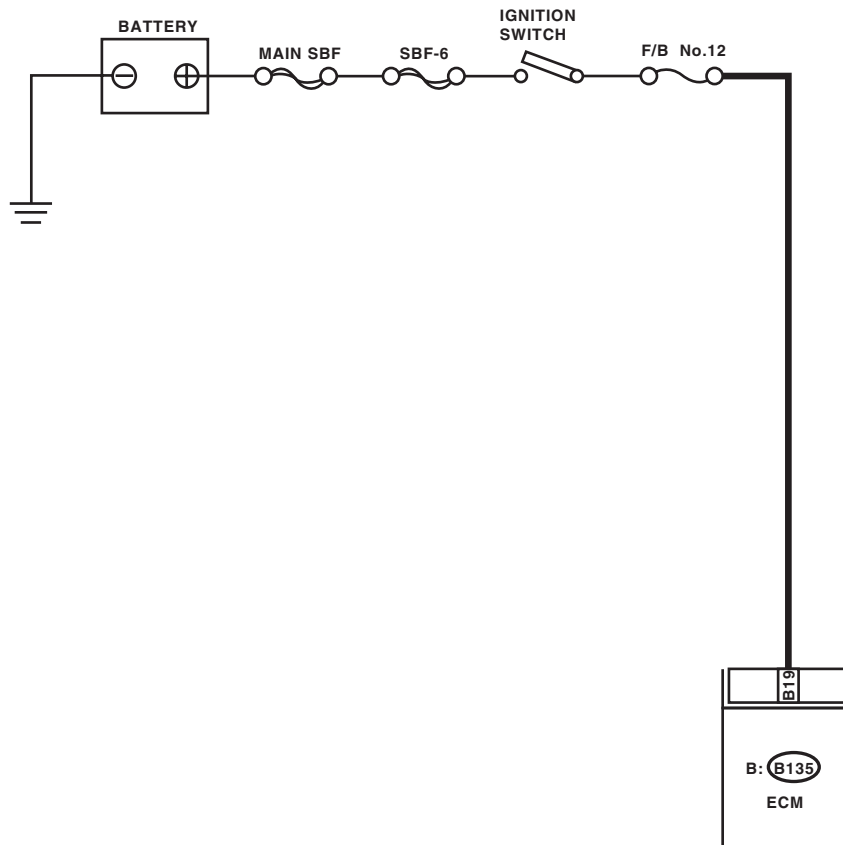

B: **B135**

1	2	3	4	5	6	7					
8	9	10	11	12	13	14	15	16	17	18	19
20	21	22	23	24	25	26	27				
28	29	30	31	32	33	34	35				

CC-00374

Diagnostic Procedure with Diagnostic Trouble Code (DTC)

CRUISE CONTROL SYSTEM (DIAGNOSTICS)

	Step	Check	Yes	No
1	CHECK IGNITION SWITCH CIRCUIT 1) Turn the ignition switch to OFF. 2) Disconnect the ECM harness connector. 3) Turn the ignition switch to ON. 4) Measure the voltage between harness connector terminal and chassis ground. Connector & terminal (B135) No. 19 (+) — Chassis ground (-):	Is the voltage 10 V or more?	Check poor contact of ECM connector.	<ul style="list-style-type: none"> • Check fuse No. 12 (in fuse & relay box). • Check the harness for open or short circuit between ignition switch and ECM.

F: DTC 21

Malfunction of the cruise control command switch.

Refer to DTC 11 for diagnostic procedure.

<Ref. to CC(diag)-15, DTC 11, Diagnostic Procedure with Diagnostic Trouble Code (DTC).>

G: DTC 22

DIAGNOSIS:

Open or short circuit in vehicle speed sensor system.

TROUBLE SYMPTOM:

Cruise control cannot be set. (Cancelled immediately.)

	Step	Check	Yes	No
1	CHECK ABS WARNING LIGHT. 1) Turn the ignition switch to ON. 2) After the initial operation of combination meter is completed, check if the VDC warning light continues to illuminate.	Does the VDC warning light continue to illuminate?	Check the VDCCM. <Ref. to VDC(diag)-2, Basic Diagnostic Procedure.>	Go to step 2.
2	CHECK LAN COMMUNICATION CIRCUIT ERROR DISPLAY Check if the communication error is displayed on the odo/trip meter in combination meter.	Is the error code "Er xx" displayed on odo/trip meter?	Check the LAN communication circuit. <Ref. to LAN(diag)-2, Basic Diagnostic Procedure.>	Replace the ECM. <Ref. to FU(H6DO)-33, Engine Control Module (ECM).>

Diagnostic Procedure with Diagnostic Trouble Code (DTC)

CRUISE CONTROL SYSTEM (DIAGNOSTICS)

H: DTC 24

Malfunction of the cruise control related switch.

Refer to DTC 11 for diagnostic procedure.

<Ref. to CC(diag)-15, DTC 11, Diagnostic Procedure with Diagnostic Trouble Code (DTC).>

I: DTC 25

Malfunction of the brake input circuit in ECM.

Refer to the Engine Diagnostic Procedure for diagnostic procedure.

<Ref. to EN(H6DO)(diag)-2, PROCEDURE, Basic Diagnostic Procedure.>

J: DTC 31

Malfunction of the engine speed signal.

Abnormal increase of engine speed is detected.

Gear is set to 1st or Reverse position.

After driving at the 2nd gear position or more, perform the cruise setting again. If the DTC is not detected, it is normal.

K: DTC 32

Out of vehicle speed range of system operation.

Refer to DTC 22 for diagnostic procedure.

<Ref. to CC(diag)-22, DTC 22, Diagnostic Procedure with Diagnostic Trouble Code (DTC).>

L: DTC 34

Malfunction of throttle opening angle continuous time is detected.

The vehicle has been driven at a speed higher than set speed for a long time (approximately 10 minutes) during cruise driving.

DTC is detected when driving for a long period of time at higher speed than appropriate cruise speed by operating accelerator pedal.

Release the cruise setting. If it is not detected again, it is normal.

M: DTC 35

Detected when it is impossible to perform the vehicle speed feedback.

Set vehicle speed cannot be kept for some reasons (steep uphill, unreleased parking brake, etc.) during cruise driving.

DTC is detected when driving condition is not suitable for cruise control.

Perform cruise set operation again after clearing the possible cause.

N: DTC 41

VDC/TCS has operated.

Vehicle dynamics control (VDC) or TCS is operated during cruise driving or cruise setting.

<Ref. to VDC(diag)-2, PROCEDURE, Basic Diagnostic Procedure.>

O: DTC 43

ABS/VDC malfunction is detected.

VDC malfunction is detected during cruise driving or cruise setting.

<Ref. to VDC(diag)-2, PROCEDURE, Basic Diagnostic Procedure.>

P: DTC 44

Body integrated unit malfunction is detected.

Body integrated unit system malfunction is detected during cruise driving or cruise setting.

<Ref. to LAN(diag)-2, PROCEDURE, Basic Diagnostic Procedure.>

Q: DTC 45

Malfunction of the combination meter is detected.

Combination meter malfunction is detected during cruise driving or cruise setting.

<Ref. to LAN(diag)-2, PROCEDURE, Basic Diagnostic Procedure.>

Diagnostic Procedure with Diagnostic Trouble Code (DTC)

CRUISE CONTROL SYSTEM (DIAGNOSTICS)

R: DTC 61

Malfunction of the brake light switch is detected.

Refer to DTC 12 for diagnostic procedure.

<Ref. to CC(diag)-17, DTC 12, Diagnostic Procedure with Diagnostic Trouble Code (DTC).>

S: DTC 62

Neutral position switch malfunction is detected.

Refer to DTC 14 for diagnostic procedure.

<Ref. to CC(diag)-19, DTC 14, Diagnostic Procedure with Diagnostic Trouble Code (DTC).>

T: DTC 63

Malfunction of vehicle speed signal variation is detected.

Refer to DTC 22 for diagnostic procedure.

<Ref. to CC(diag)-22, DTC 22, Diagnostic Procedure with Diagnostic Trouble Code (DTC).>

U: DTC 64

Malfunction related to engine is detected.

Refer to the Engine Diagnostic Procedure for diagnostic procedure.

<Ref. to EN(H6DO)(diag)-2, PROCEDURE, Basic Diagnostic Procedure.>

V: DTC 65

Cruise control command switch malfunction is detected.

While the command switch is pressed ON for a long time (approximately two minutes), stuck ON open circuit is detected.

Refer to DTC 11 for diagnostic procedure.

<Ref. to CC(diag)-15, DTC 11, Diagnostic Procedure with Diagnostic Trouble Code (DTC).>

W: DTC 66

Cruise control calculation malfunction is detected.

Refer to the Engine Diagnostic Procedure for diagnostic procedure.

<Ref. to EN(H6DO)(diag)-2, PROCEDURE, Basic Diagnostic Procedure.>

IMMOBILIZER (DIAGNOSTICS)

IM(diag)

	Page
1. Basic Diagnostic Procedure	2
2. General Description	3
3. Electrical Component Location	5
4. Immobilizer Control Module I/O Signal	6
5. Subaru Select Monitor	7
6. Read Diagnostic Trouble Code (DTC)	8
7. Clear Memory Mode	9
8. Diagnostics Chart for Security Indicator Light	10
9. List of Diagnostic Trouble Code (DTC)	14
10. Diagnostic Procedure with Diagnostic Trouble Code (DTC)	16