

## 10.Side Garnish

### A: REMOVAL

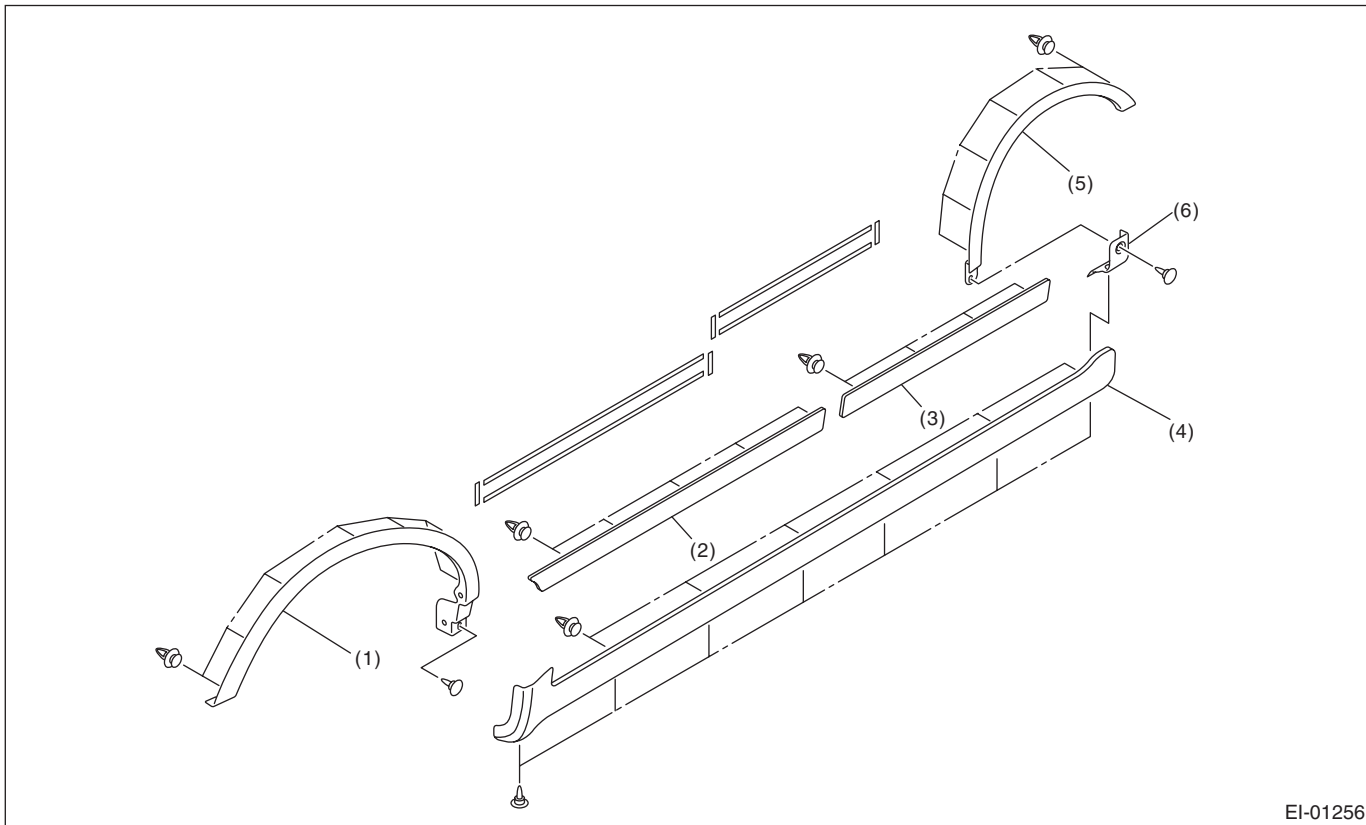

EI-01256

- |                          |                       |                          |
|--------------------------|-----------------------|--------------------------|
| (1) Front fender garnish | (3) Rear door garnish | (5) Rear quarter garnish |
| (2) Front door garnish   | (4) Side sill garnish | (6) Garnish end cover    |

1) Remove the clip on the bottom side of the vehicle body, and the clip that is attached with the front and rear mudguards.

2) Remove the double sided tape and the clip on the vehicle side, and remove the side sill spoiler.

(1) Insert a thin piece of string (A) of 0.8 mm (0.031 in) (fishing line, etc.) between the vehicle body and the door garnish.

(2) Cut the double sided tape, and remove the clip using a clip remover.

#### NOTE:

- To optimize the effect of solvent, slide the thread along body without removing the double-sided tape on the surface of body and spoiler.
- If it is difficult to remove the double-sided tape, warm it up to approx. 40°C (104°F).
- If the double-sided tape remains thick on the surface due to interfacial peeling, apply solvent after slicing off the double-sided tape using a cutter.

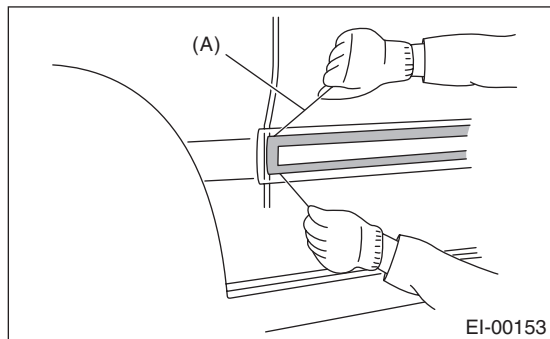

EI-00153

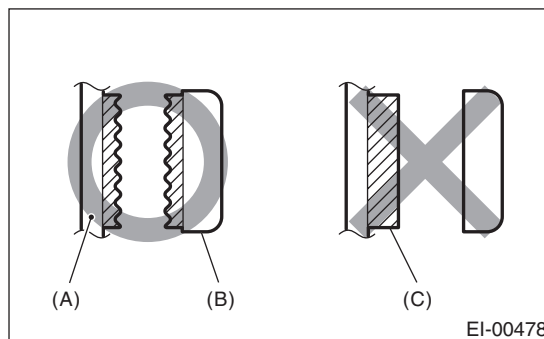

EI-00478

- |                       |
|-----------------------|
| (A) Panel             |
| (B) Door garnish      |
| (C) Double-sided tape |

(3) Apply masking tape around the double-sided tape remaining on the surface of body or spoiler.

(4) Apply solvent uniformly on the double-sided tape using a brush.

**CAUTION:**

- Do not use solvent to the body which has been repaired with lacquer paint.
- Wipe off immediately when the solvent is attached on surface of the body or spoiler.

**Solvent:****3M 8907 or equivalent**

(5) Cover the area where solvent is applied using plastic wrap (A), and then heat the double-sided tape for 5 to 10 minutes in 40 — 60°C (104 — 140°F) using a heat light (B).

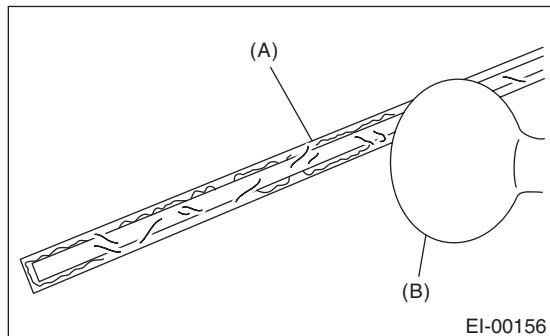
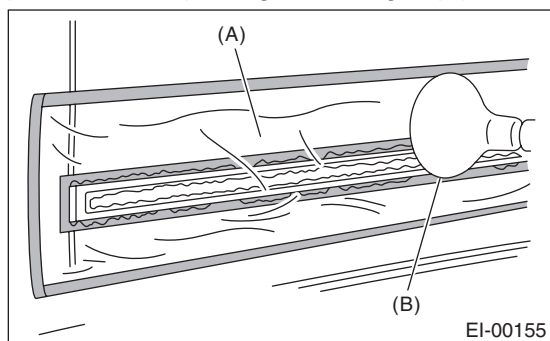
**CAUTION:**

**Do not heat the double-sided tape until the surface becomes white and excessively dried.**

(6) Remove the double-sided tape using a plastic spatula.

(7) After completely removing the double-sided tape, detach the masking tape and clean the surface using a cotton cloth damped with white gasoline.

3) Remove the front fender garnish and rear quarter garnish.

4) Remove the door garnish.

**B: INSTALLATION**

1) Apply primer to the door garnish surface where the double-sided tape is to be adhered, and then adhere the double-sided tape as shown in the figure.

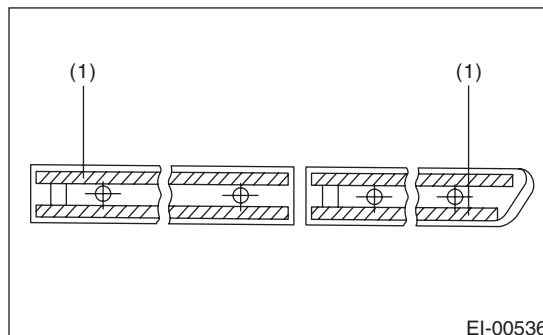

- (1) Double-sided tape:  
Thickness = 1.2 mm (0.047 in)  
Width 5 mm (0.197 in)

**Primer:****3M K-500 or equivalent****Double-sided tape:****3M 5531-5 or equivalent**

2) Heat the adhering part using a heat light.

Body side: 40 — 60°C (104 — 140°F)

Door garnish side: 20 — 30°C (68 — 86°F)

3) Peel off the backing sheet of double-sided tape, align the clip position, and then adhere the tape to the body while taking care to avoid air entering.

**CAUTION:**

**To keep the adhesion, do not wash the vehicle within 24 hours from installation.**