

15.Rear Gate Glass

A: REMOVAL

- 1) Remove the rear wiper motor. <Ref. to WW-19, REMOVAL, Rear Wiper Motor.>
- 2) Disconnect the electrical connectors from rear defogger terminal.
- 3) Remove the glass in the same procedure as for windshield glass. <Ref. to GW-18, REMOVAL, Windshield Glass.>

B: INSTALLATION

- 1) Mount the fastener on the body.
- 2) Install the dam rubber.
- 3) Cut off the cartridge nozzle tip as shown and set it in sealant gun.

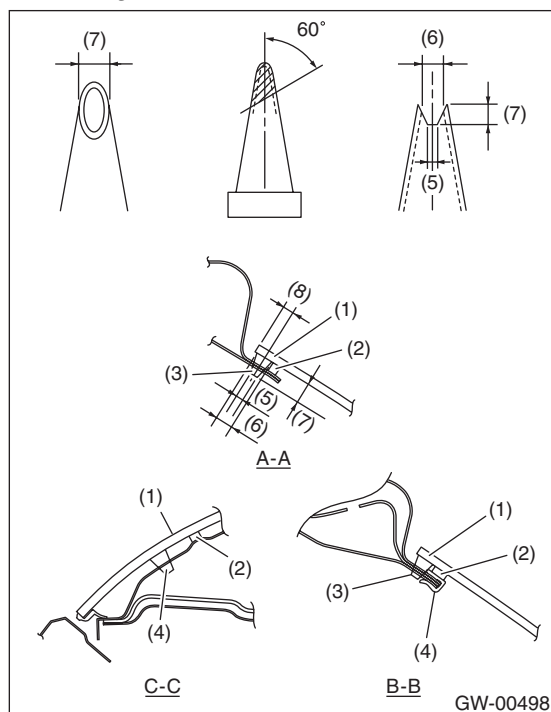

- (1) Glass
- (2) Spacer
- (3) Adhesive
- (4) Fastener
- (5) 4 mm (0.15 in)
- (6) 8 mm (0.31 in)
- (7) 10 mm (0.39 in)
- (8) 5.5 mm (0.22 in)

4) Apply adhesive in the same procedure as for windshield glass. <Ref. to GW-19, INSTALLATION, Windshield Glass.>

5) Insert the glass clip pin into rear gate hole, push on the area around the clip pin to secure it, and then push lightly all around the area to seal it.

Rear Gate Glass

GLASS/WINDOWS/MIRRORS

6) About one hour after installation, conduct a leak test.

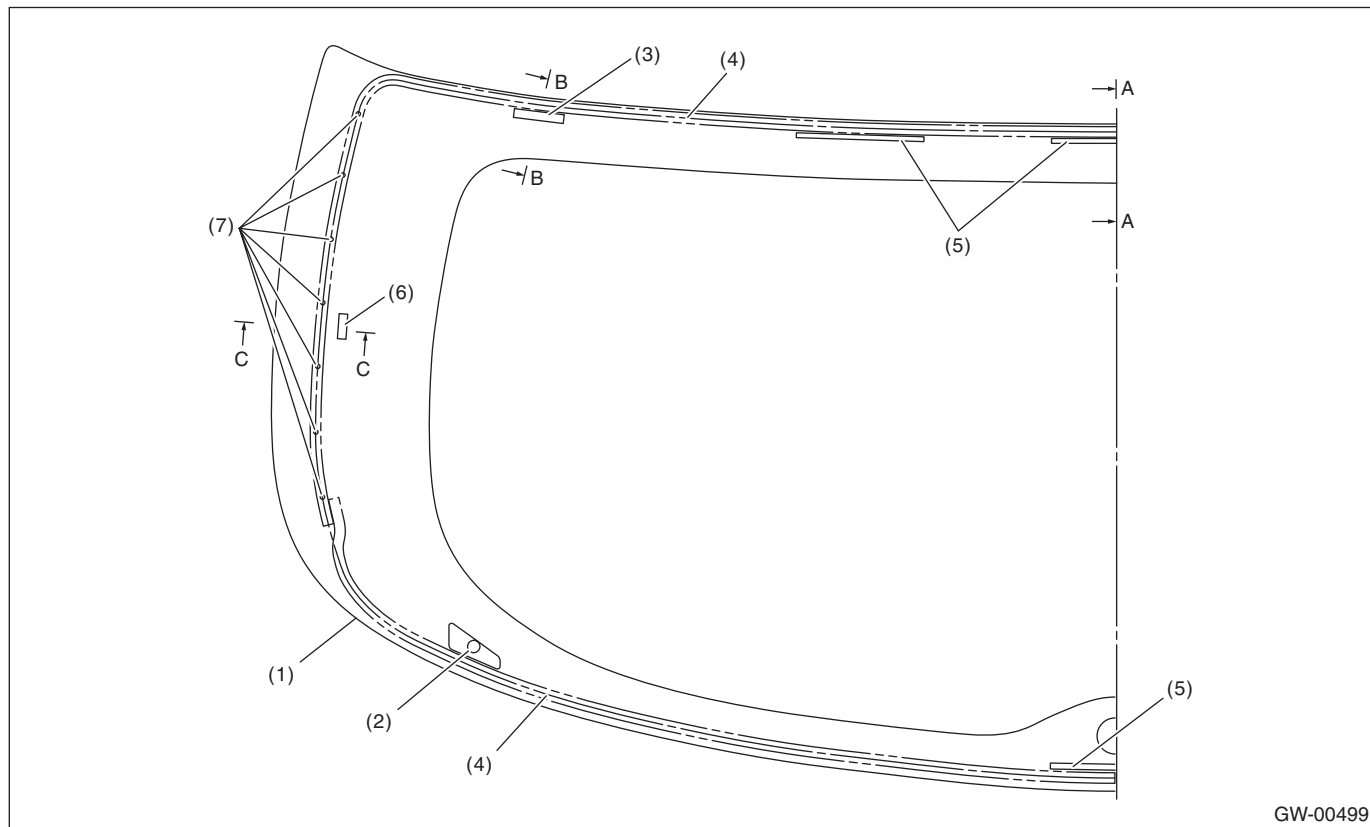

- | | | |
|--------------------|----------------|-----------------------------------|
| (1) Glass | (4) Adhesive | (6) Spacer |
| (2) Glass clip pin | (5) Dam rubber | (7) Marks for applying the primer |
| (3) Fastener | | |

7) After completion of all work, allow the vehicle to stand for about 24 hours.

NOTE:

- When door is opened/closed after glass is bonded, always lower the door glass first, and then open/close it carefully.
- Move the vehicle slowly.
- For minimum drying time and vehicle standing time before driving after bonding, follow instructions or instruction manual from the adhesive manufacturer.
- When a vehicle is returned to the user, tell him or her that the vehicle should not be subjected to heavy impact for at least three days.

8) Connect the rear defogger terminals.

9) Install the rear wiper. <Ref. to WW-19, INSTALLATION, Rear Wiper Motor.>