

Front Fog Light Assembly

LIGHTING SYSTEM

15. Front Fog Light Assembly

A: REMOVAL

- 1) Disconnect the ground cable from the battery.
- 2) Disengage the three clips, and then turn over the lower mud guard.
- 3) Disconnect the harness connector.
- 4) Remove the two mounting bolts, and pull and detach the fog light assembly.

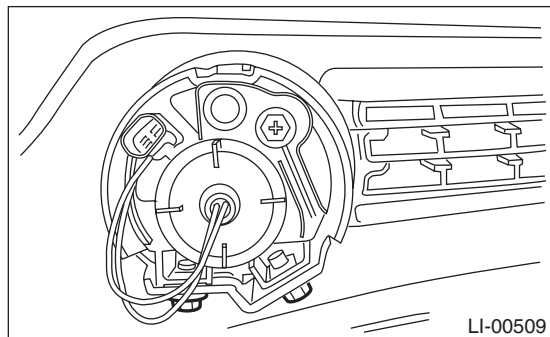

B: INSTALLATION

Install in the reverse order of removal.

C: ADJUSTMENT

Fog light aiming

NOTE:

Before checking the fog light beam level, be sure of the following:

- Check the area around the fog light for any scratches, damage or other type of deformation.
 - Make sure that the vehicle is parked on a level surface.
 - Make sure that the inflation pressure of tires are correct.
 - Check that the vehicle fuel tank is full.
- 1) Bounce the vehicle several times to normalize the suspension.
 - 2) Make certain that someone is seated in the driver's seat.
 - 3) Measure the height of the center of fog light.
 - 4) Disengage the three clips, and then turn over the mud guard.
 - 5) Insert a Phillips driver into the adjustment hole and adjust the front fog light pattern.

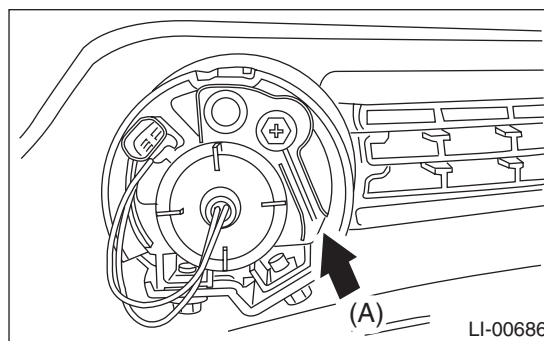

(1) Adjustment hole

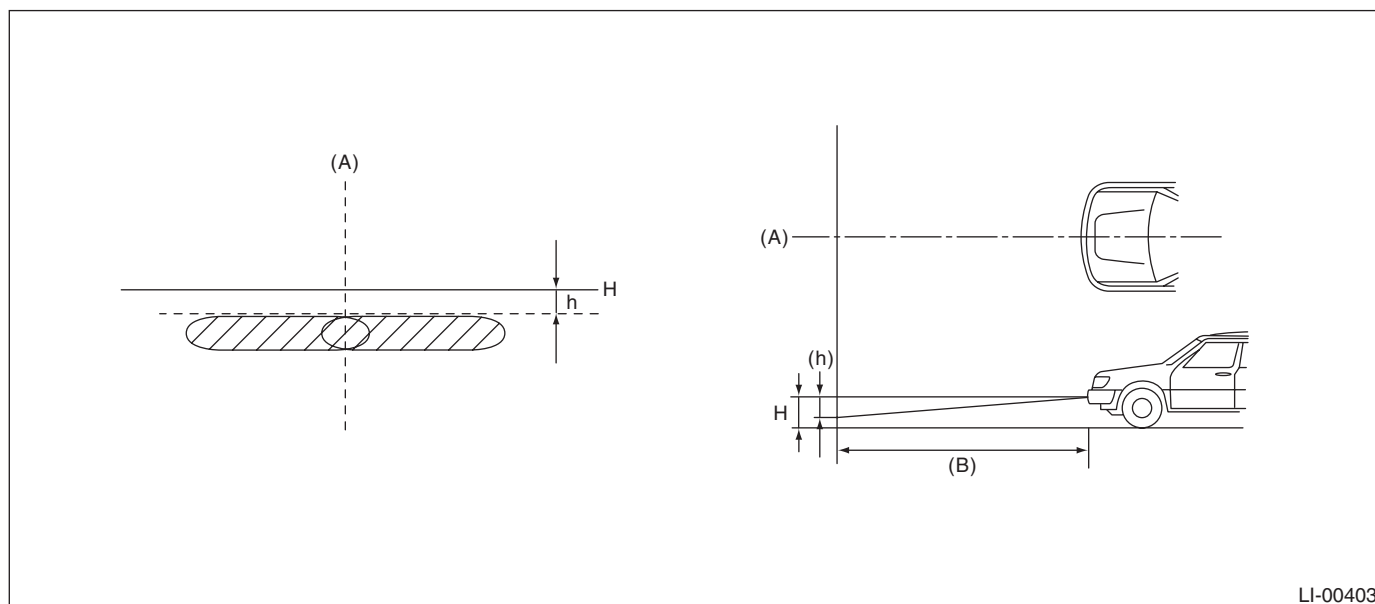

(A) Center of vehicle

(B) 3 m (10 ft)

(H) Height of the center of fog light (mm)

h Dimension mm (in)	40 (1.57)
---------------------	-----------