

5. Back-up Light System

A: WIRING DIAGRAM

1. BACK-UP LIGHT

<Ref. to WI-96, WIRING DIAGRAM, Back-up Light System.>

B: INSPECTION

1. BACK-UP LIGHT RELAY

Measure the resistance between headlight relay terminals when connecting terminal No. 4 to the battery positive terminal and terminal No. 3 to the battery ground terminal.

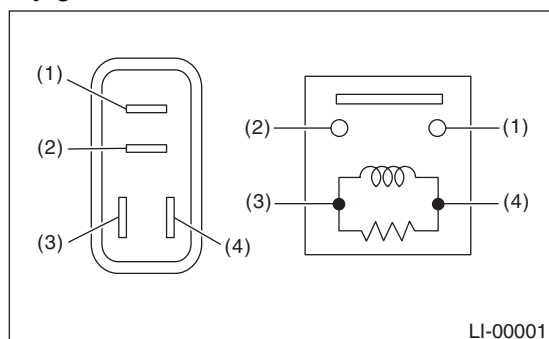

Continuity	Terminal No.	Standard
Yes	1 and 2	Less than 1 Ω
No		1 M Ω or more