

General Description

SEAT BELT SYSTEM

1. General Description

A: COMPONENT

1. FRONT SEAT BELT

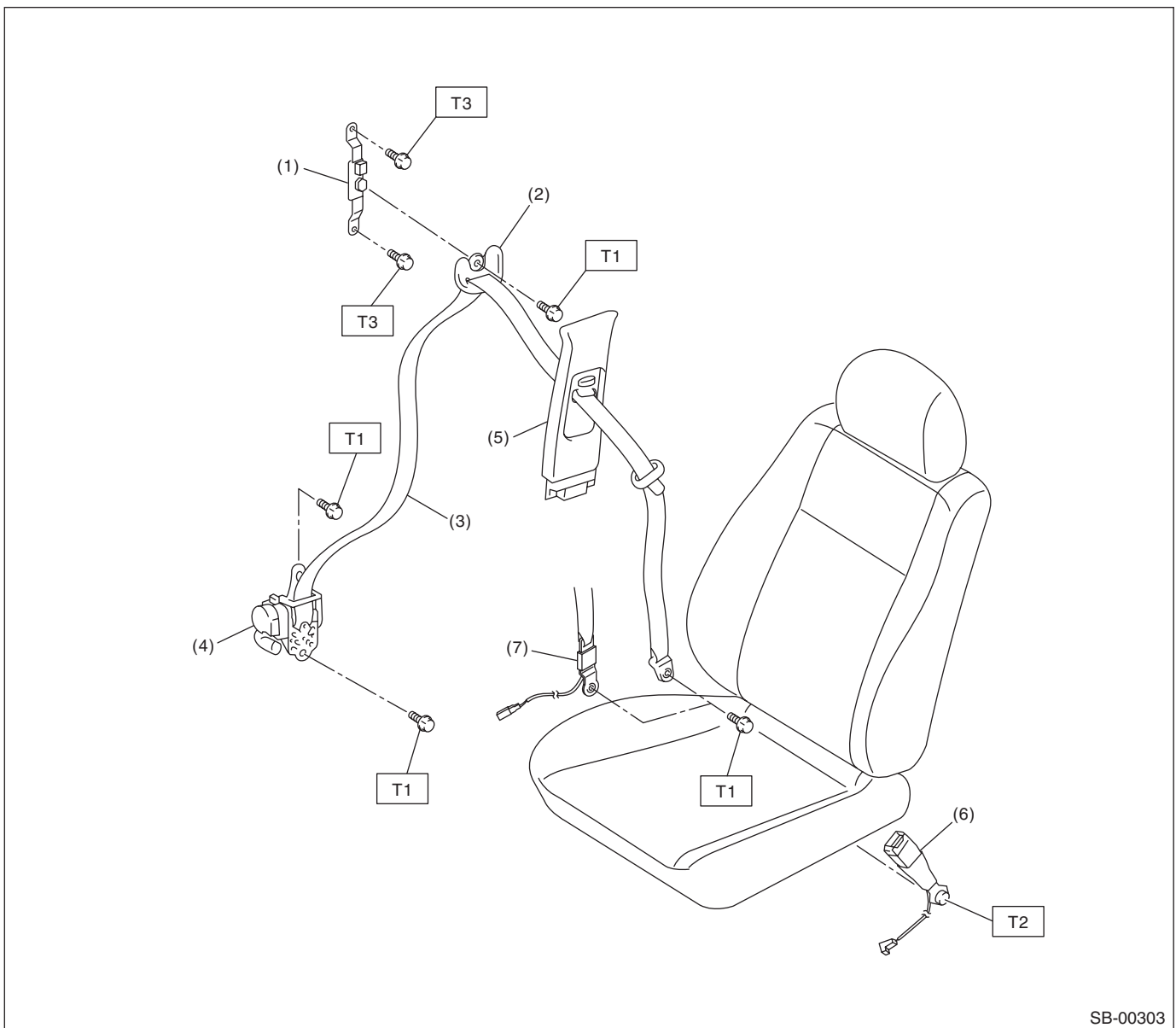

- | | |
|----------------------------|---|
| (1) Adjustable anchor ASSY | (5) Center pillar upper trim |
| (2) Shoulder anchor | (6) Inner seat belt ASSY |
| (3) Outer seat belt ASSY | (7) Belt tension sensor (passenger's side only) |
| (4) Seat belt retractor | |

Tightening torque: N·m (kgf·m, ft·lb)

T1: 30 (3.1, 22)

T2: 38 (3.9, 28)

T3: 53 (5.4, 39)

2. SECOND SEAT BELT

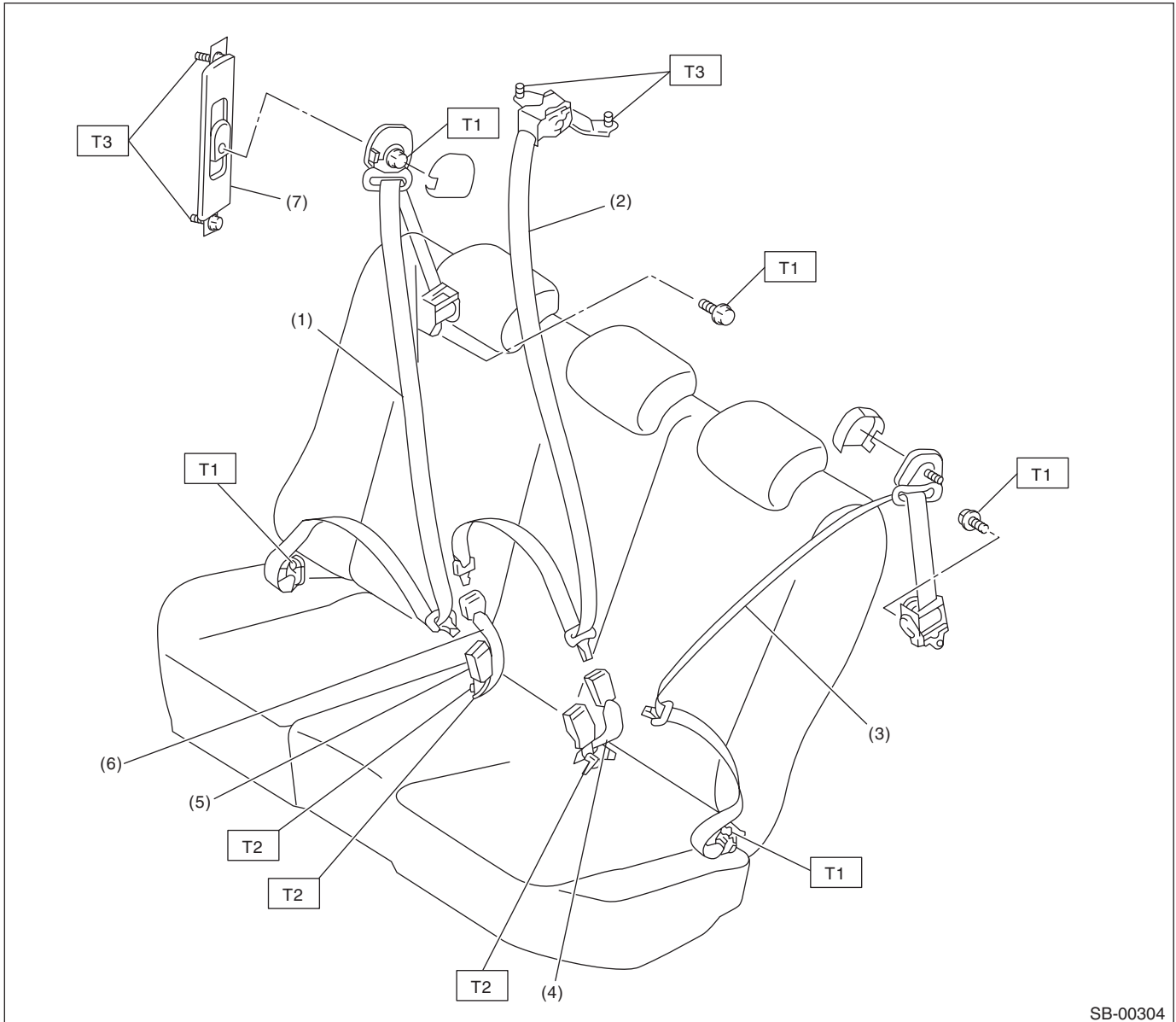

SB-00304

- | | |
|------------------------------------|---|
| (1) Outer seat belt RH ASSY | (5) Inner seat belt RH ASSY |
| (2) Shoulder seat belt center ASSY | (6) Shoulder seat belt center buckle ASSY |
| (3) Outer seat belt LH ASSY | (7) Adjustable anchor ASSY |
| (4) Inner seat belt LH ASSY | |

Tightening torque: N·m (kgf·m, ft·lb)

T1: 30 (3.1, 22)

T2: 38 (3.9, 28)

T3: 53 (5.4, 39)

General Description

SEAT BELT SYSTEM

3. THIRD SEAT BELT

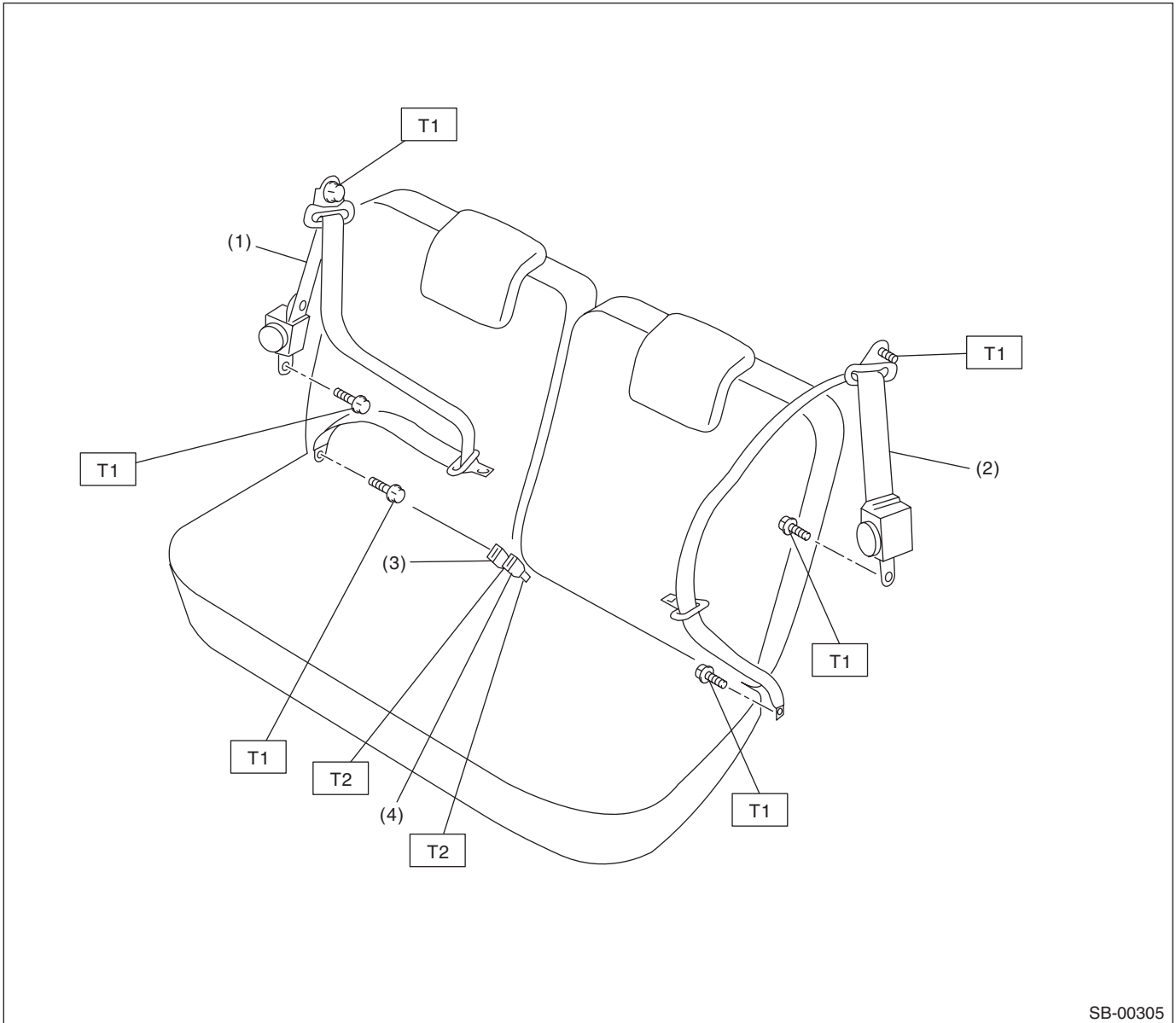

SB-00305

- (1) Outer seat belt RH ASSY
- (2) Outer seat belt LH ASSY
- (3) Inner seat belt RH ASSY

- (4) Inner seat belt LH ASSY

Tightening torque: N·m (kgf·m, ft·lb)

T1: 30 (3.1, 22)

T2: 38 (3.9, 28)

B: CAUTION

- Before starting the work, turn the ignition switch to OFF, disconnect the battery ground cable and wait for 20 seconds or more.
- The pretensioner system has a backup power source. The pretensioner might deploy if you do not wait for 20 seconds or more before starting work.
- Do not drop or apply any impact to the pretensioner.
- If oil, grease or water gets on the pretensioner, wipe it off immediately with a dry cloth.
- Do not expose the pretensioner to high temperature or flame.
- Do not allow current to flow through or voltage to reach the pretensioner. Do not use a circuit tester to check resistance of the pretensioner.
- Do not disassemble or attempt to repair the pretensioner. If it is dented, cracked or deformed, replace it with a new part.
- Do not use the airbag or pretensioner parts from other vehicles. Always replace parts with new parts.
- When handling a seat belt with deployed pretensioner, wear gloves and goggles. Wash your hands afterwards.
- Do not reuse a seat belt with deployed pretensioner.
- If material from the airbag enters the eyes or contacts skin during deployment, wash it away with clean water, and then consult a doctor.

C: PREPARATION TOOL

1. GENERAL TOOL

TOOL NAME	REMARKS
Circuit tester	Used for inspecting the seat belt warning system.
TORX® T50	Used for removing and installing the inner seat belt assembly.