

17. Ignition Key Lock

A: REPLACEMENT

- 1) Disconnect the ground cable from the battery.
- 2) Remove the steering column. <Ref. to PS-17, REMOVAL, Tilt Steering Column.>
- 3) Secure the steering column in a vise. Remove the bolt with a drill.

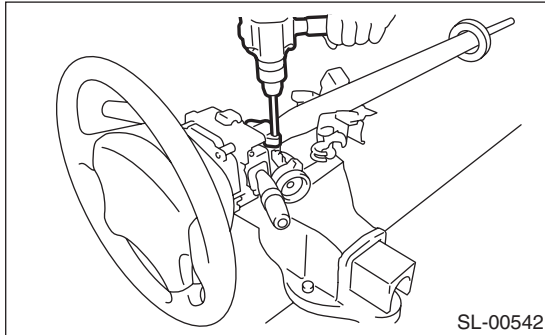

- 4) Remove the ignition key lock.
- 5) Using a new bolt, tighten the bolts all the way.

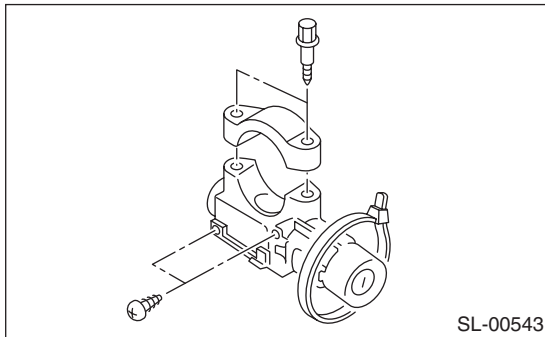

B: INSPECTION

- 1) Remove the instrument panel lower cover.
- 2) Remove the lower column cover.
- 3) Unfasten the fixing clip which secures harness, and then disconnect the connector of the ignition switch from body harness.
- 4) Turn the ignition key plate to each position and check the continuity between terminals of ignition connector.

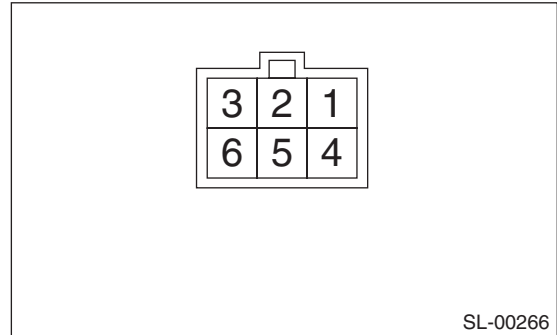

Switch position	Terminal No.	Standard
LOCK	—	—
ACC	No. 3 and No. 4	Less than 1 Ω
ON	No. 3, No. 1 and No. 4 No. 3 and No. 6	Less than 1 Ω
ST	No. 3 and No. 1 No. 3, No. 2 and No. 6	Less than 1 Ω

If NG, replace the ignition switch.