

Combination Switch (Wiper)

WIPER AND WASHER SYSTEMS

3. Combination Switch (Wiper)

A: REMOVAL

- 1) Disconnect the ground cable from the battery.
- 2) Remove the driver's airbag module. <Ref. to AB-14, REMOVAL, Driver's Airbag Module.>
- 3) Remove the steering wheel. <Ref. to PS-14, REMOVAL, Steering Wheel.>
- 4) Remove the screws and remove the steering column covers (upper & lower).

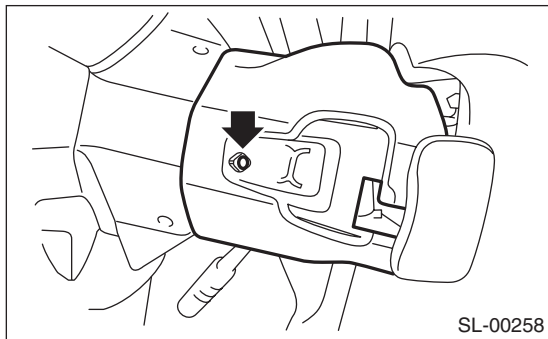

- 5) Disconnect the connector from the combination switch.
- 6) Remove the three screws, and pull out the combination base switch assembly toward you.

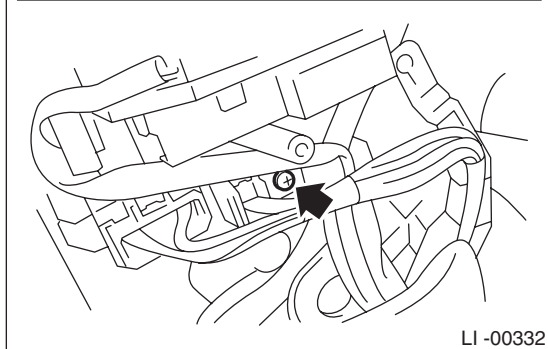
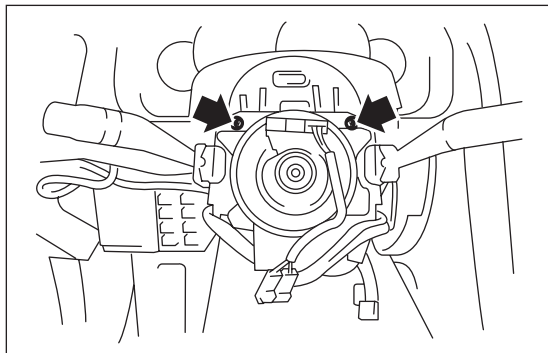

- 7) Remove the screws which secure the switch, then remove the combination switch.

B: INSTALLATION

Install in the reverse order of removal.

C: INSPECTION

1. COMBINATION SWITCH

- 1) Inspect the continuity between each connector terminal.

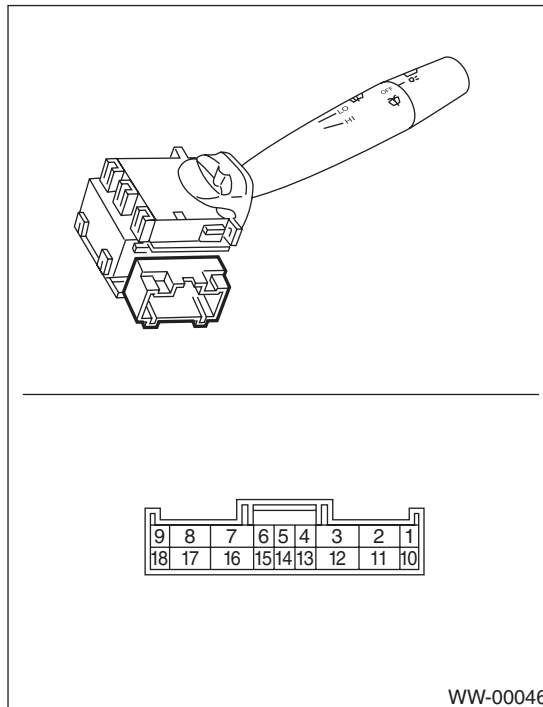

	Switch position	Terminal No.	Standard
Front	LO	7 and 17	Less than 1 Ω
	HI	8 and 17	Less than 1 Ω
	Washer ON	2 and 11	Less than 1 Ω
Rear	Washer ON	2 and 12	Less than 1 Ω
	OFF	2 and 10	1 MΩ or more
		2 and 12	
		2 and 13	
		10 and 12	
		10 and 13	
12 and 13			
INT	2 and 13	Less than 1 Ω	
ON	2 and 10	Less than 1 Ω	
Washer ON	2 and 12	Less than 1 Ω	
	12 and 10		
		2 and 10	

- 2) If continuity is not as specified, replace the switch.

Combination Switch (Wiper)

2. FRONT WIPER

1) Check with Subaru Select Monitor

When the front wiper switch is operated, check the input signal using the Subaru Select Monitor.

- (1) Connect the Subaru Select Monitor to data link connector.
- (2) Turn the ignition switch to ON.
- (3) Select {Integ. unit} from main menu.
- (4) Select the {Current Data Display & Save}.
- (5) Check the input signal when the front wiper switch is set to LO or HI.

Check	Yes	No
Is the input signal normal?	Finish the diagnosis.	Replace the body integrated unit. <Ref. to SL-51, Body Integrated Unit.>

2) Check the intermittent operation (inspection of the wiper switch alone)

- (1) Set the voltage meter between connector terminal No. 7 (+) and No. 2 (-).
- (2) Connect the battery between connector terminal No. 7 (+) and No. 2 (-).
- (3) Turn the wiper switch to INT.
- (4) Connect the battery ground terminal to the connector terminal No. 16 for five seconds.
- (5) After connecting the battery ground terminal for five seconds in step (4), connect the battery positive terminal to the connector terminal No. 16 for five seconds.
- (6) After connecting the battery ground terminal and the battery positive terminal to the connector terminal No. 16 for five seconds each in step (4) and (5), connect the ground terminal to the connector terminal No. 16 again.
- (7) Perform the step (1) to (6) above at MIN and MAX position of the intermittent control switch. If operation is not as specification, replace the wiper switch assembly.

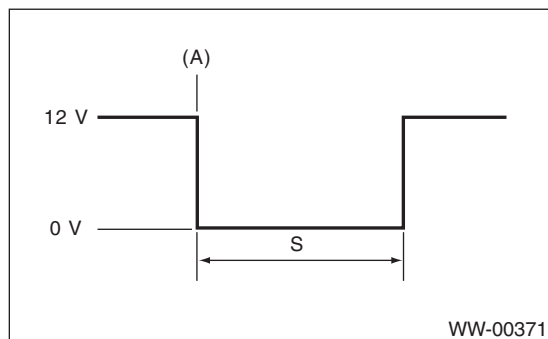

S: Intermittent down-time (sec.) (A): Connect battery terminal to No. 16 in Step (4).

Intermittent stationary time specification MIN: Approx. 4 seconds
MAX: Approx. 21 seconds

3) Inspect the vehicle speed response (With the wiper switch installed on the vehicle)

(1) Operational check

Position the front wiper switch to INT, then measure the intermittent stationary time at each vehicle speed.

Switch position	Vehicle speed (km/h (MPH))	Intermittent stationary time (sec.)
MIN.	0 (0)	Approx. 4
	30 (19)	Approx. 1.5
	60 (37)	Approx. 1
MAX.	0 (0)	Approx. 21
	30 (19)	Approx. 19.5
	60 (37)	Approx. 18

If operation is not as specified, replace the switch.

(2) Check vehicle speed signal

Raise the vehicle speed to 10 km/h (6 MPH) or more, then measure the voltage between the wiper switch connector and the chassis ground.

Terminals

No. 15 (+) — Chassis ground (-):

Check	Yes	No
Does the voltage repeat 12 V and 0 V?	Vehicle speed signal is normal.	Replace the wiper switch.

- (3) Check the vehicle speed signal harness
Measure the resistance between the wiper switch connector and the VDC control module.

Terminals

Wiper switch connector No. 15 — VDC control module No. 33:

Check	Yes	No
Is the resistance 0 Ω?	Replace the wiper switch.	Repair the harness.

Combination Switch (Wiper)

WIPER AND WASHER SYSTEMS

3. REAR WIPER

1) Check with Subaru Select Monitor

Step	Check	Yes	No
1 CHECK INPUT OF REAR WIPER SWITCH. Check the input from body integrated unit using the Subaru Select Monitor. 1) Connect the Subaru Select Monitor to data link connector. 2) Turn the ignition switch to ON. 3) Select {Integ. unit} from main menu. 4) Select the {Current Data Display & Save}. 5) Check the input of the rear wiper switch.	Is the input normal?	Go to step 2.	Check the rear wiper switch. <Ref. to WW-6, INSPECTION, Combination Switch (Wiper).>
2 CHECK OUTPUT OF BODY INTEGRATED UNIT. When the rear wiper switch is operated, check the output using the Subaru Select Monitor. 1) Turn the ignition switch to ON. 2) Operate the rear wiper switch and set to each position of ON and INT. 3) At this time, check the body integrated unit output.	When set to ON, is ON output continuous? When set to INT, is ON/OFF output repeated? (INT OFF time (when vehicle parked): 12 seconds)	Check the rear wiper motor. <Ref. to WW-19, INSPECTION, Rear Wiper Motor.>	Replace the body integrated unit. <Ref. to SL-51, Body Integrated Unit.>

Combination Switch (Wiper)

2) Check rear wiper motor circuit

	Step	Check	Yes	No
1	<p>CHECK POWER SUPPLY CIRCUIT OF THE REAR WIPER MOTOR.</p> <p>1) Disconnect the harness connector of the rear wiper motor.</p> <p>2) Turn the ignition switch to ACC.</p> <p>3) Measure the voltage between the rear wiper motor harness connector terminal and chassis ground.</p> <p>Connector & terminal (D43) No. 1 (+) — Chassis ground (-):</p>	Is the voltage 10 V or more?	Go to step 2.	<ul style="list-style-type: none"> • Check the fuse (No. 23 in fuse & relay box). • Check the fusible link (No. 6 in main fuse box).
2	<p>CHECK GROUND CIRCUIT OF REAR WIPER MOTOR.</p> <p>1) Turn the ignition switch to OFF.</p> <p>2) Measure the resistance between the rear wiper motor harness connector terminal and chassis ground.</p> <p>Connector & terminal (D43) No. 3 — Chassis ground:</p>	Is the resistance less than 10 Ω?	Go to step 3.	Repair the open circuit of the rear wiper motor ground circuit.
3	<p>CHECK HARNESS BETWEEN BODY INTEGRATED UNIT AND REAR WIPER MOTOR.</p> <p>1) Turn the ignition switch to OFF.</p> <p>2) Disconnect the harness connector of body integrated unit.</p> <p>3) Disconnect the harness connector of the rear wiper motor.</p> <p>4) Measure the resistance between the harness connector terminals of the body integrated unit and rear wiper motor.</p> <p>Connector & terminal (B280) No. 1 — (D43) No. 2: (B280) No. 8 — (D43) No. 4:</p>	Is the resistance less than 10 Ω?	Go to step 4.	Repair the open circuit of the harness between body integrated unit and rear wiper motor.
4	<p>CHECK OPERATION OF REAR WIPER MOTOR.</p> <p>1) Remove the rear wiper motor.</p> <p>2) Check the rear wiper motor. <Ref. to WW-19, INSPECTION, Rear Wiper Motor.></p>	Does the rear wiper motor rotate normally?	End.	Replace the rear wiper motor.