

Wiper Relay Unit

6. Wiper Relay Unit

A: REMOVAL

- 1) Disconnect the ground cable from the battery.
- 2) Remove the wiper arm. <Ref. to WW-15, REMOVAL, Front Wiper Arm.>
- 3) Remove the cowl panel. <Ref. to EI-30, REMOVAL, Cowl Panel.>
- 4) Disconnect connector (A) of the wiper motor assembly.
- 5) Remove bolt (B) and clip (C).
- 6) Disconnect connector (D) of the wiper relay unit.

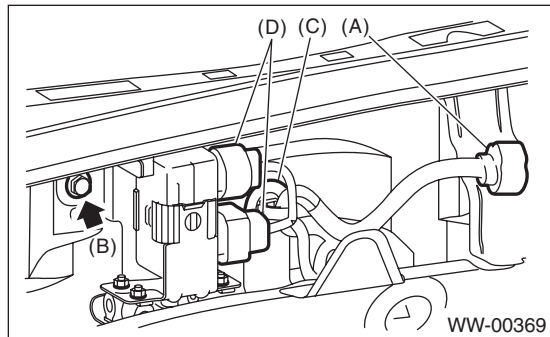

NOTE:

Unit body, bracket, and rubber mount is an assembly component and cannot be disassembled.

B: INSTALLATION

Install in the reverse order of removal.

CAUTION:

- Do not reuse the clips. Always replace them with new parts.
- Make sure the connector connection and clip insertion is secure, and confirm the contact

C: INSPECTION

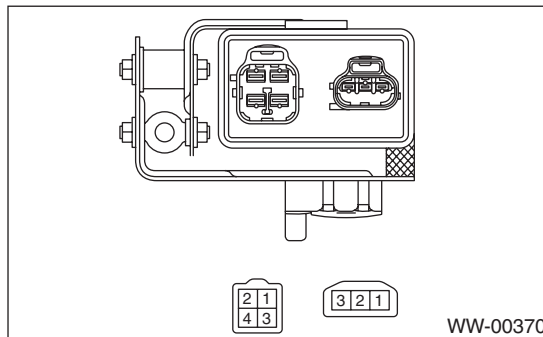

- 1) Inspect the continuity of 4 pole connector.

Terminal No.	Specification
1 and 2	Less than 1 Ω

- 2) Connect the battery to the 3 pole connector and measure the continuity of 4 pole connector.

Terminal No.		Specification
3 pole connector	4 pole connector	
2 and 3	1 and 4	Less than 1 Ω
1 and 2	3 and 4	Less than 1 Ω

- 3) When measurement value is different from the specification, replace the wiper relay unit.