

4. Water Pump

A: REMOVAL

- 1) Remove the radiator. <Ref. to CO(H6DO)-18, REMOVAL, Radiator.>
- 2) Remove the V-belts. <Ref. to ME(H6DO)-40, REMOVAL, V-belt.>
- 3) Remove the front chain cover. <Ref. to ME(H6DO)-42, REMOVAL, Front Chain Cover.>
- 4) Remove the timing chain assembly. <Ref. to ME(H6DO)-44, REMOVAL, Timing Chain Assembly.>
- 5) Remove the water pump.

NOTE:

When the water pump cannot be removed easily, screw-in the bolt (A) to the threaded end to remove water pump.

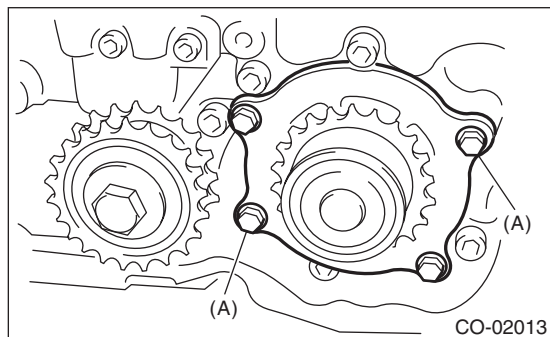

B: INSTALLATION

- 1) Install the water pump to rear chain cover.

NOTE:

- Use new O-rings.
- Apply engine coolant to O-ring.

Tightening torque:

6.4 N·m (0.65 kgf-m, 4.7 ft-lb)

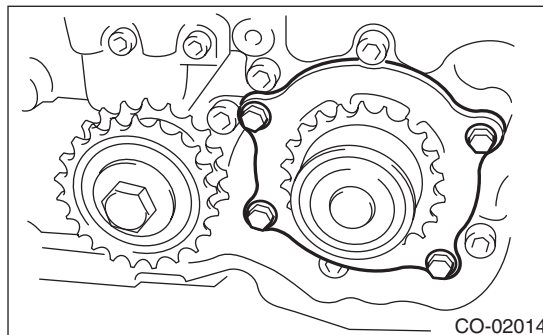

- 2) Install the timing chain assembly. <Ref. to ME(H6DO)-45, INSTALLATION, Timing Chain Assembly.>
- 3) Install the front chain cover. <Ref. to ME(H6DO)-42, INSTALLATION, Front Chain Cover.>
- 4) Install the V-belts. <Ref. to ME(H6DO)-40, INSTALLATION, V-belt.>
- 5) Install the radiator. <Ref. to CO(H6DO)-20, INSTALLATION, Radiator.>
- 6) Fill engine coolant. <Ref. to CO(H6DO)-13, FILLING OF ENGINE COOLANT, REPLACEMENT, Engine Coolant.>

C: INSPECTION

- 1) Check the water pump bearing for smooth rotation.
- 2) Check the water pump sprocket for abnormalities.