

Suzuki Carry & Every

English Version

Factory Service Manual Translation



F6A Series 660cc
Engine &
Parts Manual
Second Edition

James L. Danko

DE51V
DF51V
DC51T
DD51T
DC51B
DA52T
DB52T
DA52V

Suzuki Carry & Every

English Version

Factory Service Manual Translation

F6A Engine Manual

**Carry Truck 660cc
2WD &4WD**

**Every Van 660cc
AT-MT Models**

Suzuki Kei Vehicles Series

**Written By,
James Danko**

Second Edition 2008

Copyright © 2008 by James Danko

All rights reserved. All text and graphics in this publication if the author, unless otherwise noted or credited. It is unlawful to reproduce-or copy in anyway-resell, or redistribute this information without the express written permission of the publisher.

This book is an independent publication, and the author and/or publisher thereof are not in anyway associated with, and are not authorized to act on behalf of any of the manufactures listed in this book. All registered trademarks are the property of their owners. The publisher reserves the right to revise this publication or change its content from time to time without obligation to notify any persons of such revision or changes.

Edited By: James L. Danko

Artwork: James L. Danko©

Layout By: James L. Danko

Printed in U.S.A

Yokohama Motors Japan is a solely owned division of Nippon Security Inc. Yokohama Motors is a licensed new & used import/export automotive dealer based in Yokohama Japan. For more information please visit www.yokohamamotors.com

All translations from original Japanese text to English completed by James Danko.

Disclaimer: All translations from one language to another can involve technical errors. The author has found mistakes in the original Japanese text. The best suitable English vocabulary has been chosen by the author.

Credits: I would like to thank the Suzuki Motors Corporation (Japan) for their part in supplying required information.

Suzuki™ Carry© and Every© and all copyrights of said trademarks are property of Suzuki Corp, Japan.

Introduction

Due to the high request for English version manuals on Japanese mini trucks & Vans, we are publishing wide variety information to provide the mini truck community with the ability to maintain their vehicles.

Japanese mini trucks & vans are produced only for the Japanese market. Therefore, all original manuals are only available in Japanese.

Service manuals are not sold to the public in Japan, as in many countries. You must be a new car dealer to receive them. We have a few hundred in stock. We do not sell manuals from our own library. We will start publishing them in English (Translated) and our own original versions.

This book or manual is for the professional mechanic. Simple items as how to change a spark plug, or an air-filter are not in this book. It is full of diagrams and schematics that are easily understood by a professional mechanic. How to do an engine overhaul using the correct parts sizes, measurements, torque, etc. You will have the same information as the Suzuki Factory techs have.

We have manuals for all Japanese manufactures. It's a time consuming process, please check back frequently as we post more information.

For more information please visit our home page at www.yokohamamotors.com

Contents

1. Vehicle Types
2. Jacking Positions
3. VIN Decoding
4. Engine and Transmission Identification
5. Service Data and Specifications
6. Tools (OEM)
7. Engine Mounts and Frame Diagrams
8. Engine Removal
9. Intake Manifold Carry (Carbureted)
10. Intake Manifold Every Van (Carbureted)
11. Intake Manifold (Throttle Body)
12. Timing Belt Parts and Part Numbers
13. Timing Belt Tensioner Truck & Van
14. Timing Belt Replacement Truck & Van
15. Valve Lash 2 Cylinder
16. Valve Lash 4 Cylinder
17. Oil
18. Oil System Pressure Testing
19. Oil Pump Removal-Replacement
20. Cylinder Head 2 Valve Overhaul
21. Pistons Connecting Rods Cylinder Block
22. Main Bearings, Crankshaft, Cylinder Block
23. Crankshaft Inspection, Oil Seal, Flywheel
24. Parts Section
25. Conversion Charts

Suzuki Carry Truck 2WD & 4WD

DC51T



DD51T



Suzuki Every Van

DE51V



DE51V



DF51V



DF51V



Jacking Locations

Van

Front

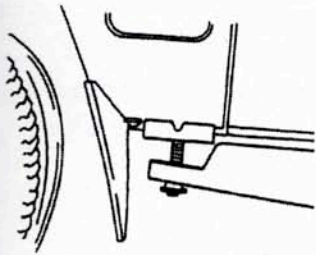

Rear

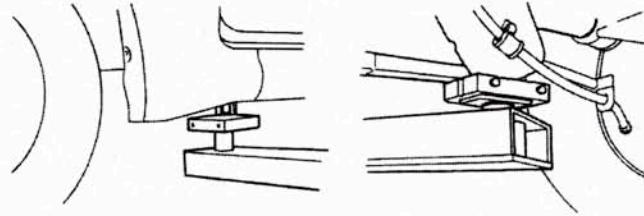

Truck

Front

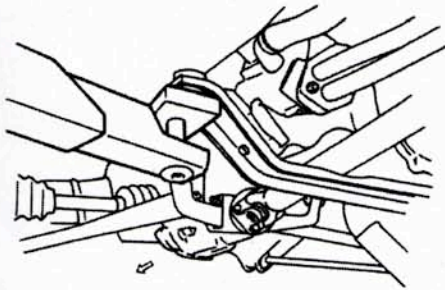

Rear

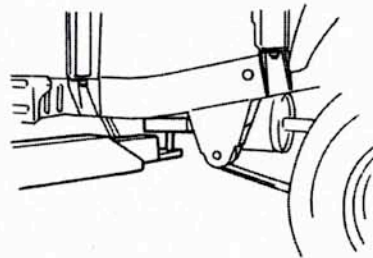

Rear

Front

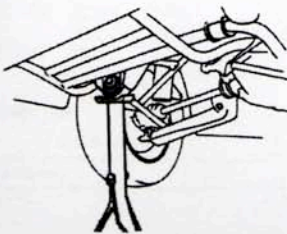

Rear

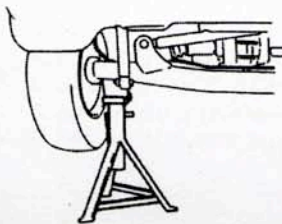

Axle

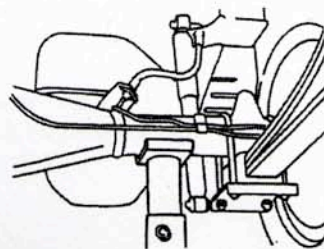

Floor Jack Locations

Front

2WD

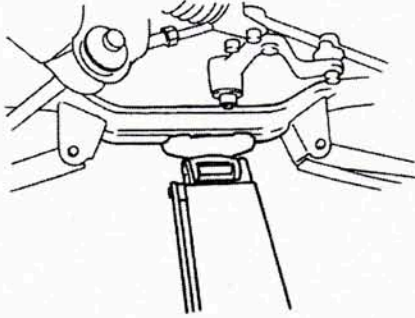

4WD

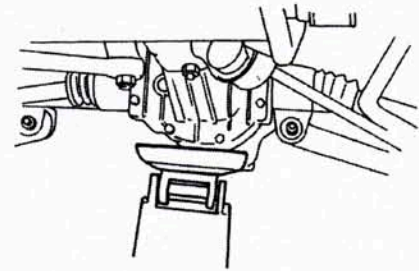

Rear
Van

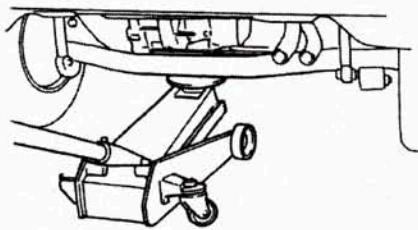

Truck

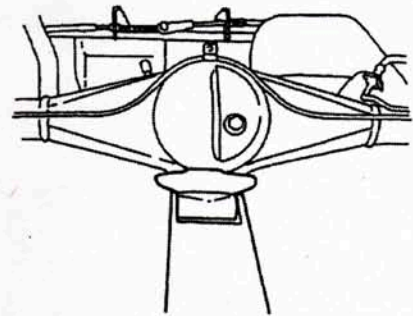

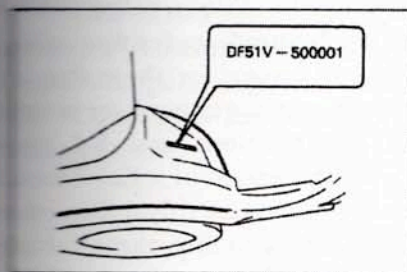

Drivers Side Inner Fender
Under Seat

Example: DE51V=Vehicle Series
500001=Production number
In Sequence

Every Van

DE51V-500001

DF51V-500001

Carry Truck

DC51T-100001~

DD51T-100001~

DC51B-100001~

Other Locations of ID Plates

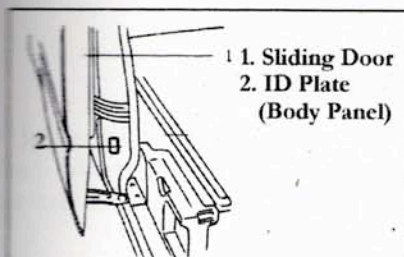

2. (R) Front Door

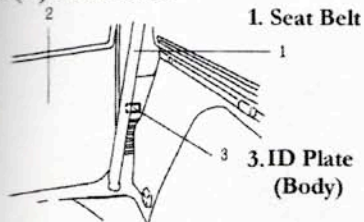

Note: Model Years do not exist in Japan, only Series.

Example: Car Manufactured in 2000 but not sold until 2008=2008. Therefore, vehicles go by codes and manufactures date means nothing in Japan.

*Note: For manufactured year check the seat belt tag or any paperwork you have from your dealer.

SUZUKI MOTOR CORPORATION JAPAN		
TYPE	V - DE51V	①
CHASSIS NO.	DE51V - 500001	②
ENGINE	F6A 657cc	③
COLOR	26U C61	④
		⑤
ENGINE NO.		⑥
スズキ株式会社		
Yokohama Motors		⑧

ID Plate Decoder

1. Vehicle Series
2. Vehicle VIN Number
3. Engine Series
4. Engine True Size(cc)
5. Body Color Code
6. Interior Color Code or Package Code
7. Makers Code (For Sales Dept. Information)
8. Suzuki Corporation(Japanese)

The Suzuki Carry has been a work horse in Japan for decades. Officially it is classified as a □□□□ (Kei-vehicle or Light Vehicle) which is symbolized by the unique yellow license plates they use for registration. All Kei-vehicles must be manufactured under law with a maximum 660cc engine displacement. Due to the obvious safety issues for their size and weight they are designed for a maximum highway speed of 80 kilometers per hour, or roughly 50MPH. Although recently with the addition of five speed transmissions and 3-4 speed automatics it is possible to travel at greater speeds. Since the average length of a Kei-Truck is roughly 10.2 feet it is not a good idea to push them to the limit as safety of drivability issues will arise. Average use in Japan for agricultural purposes and off road durability, these vehicles generally travel at 25MPH (40KPH) on local roads. As Japan is an island nation, roads are small and narrow. Kei-trucks are rarely seen going down the highway for long distance travel. The other issues of engines overheating at prolonged highway speeds. Their high winding motors do not have adequate cooling systems for long distance travel.

The Suzuki Carry is built tough and properly maintained will last for many years. The platform is durable, and easy to repair. There are still thousands of them driving around Japan that are 20-30 years old. This in itself amazing as the average life cycle of a normal car in Japan is 5-10 years.

Common uses in Japan of Carry Truck and Every Van

- Agriculture
- Construction companies
- Dump trucks
- Delivery Vans (Every Van)
- Postal
- Rescue and fire trucks
- Police Patrol
- Moving companies
- Many, many more

The basic body style has not changed much from the 1980s to 1998. The engines from the late 1970s to the beginning of 1980s saw the change from the 550cc engine to the 660cc version. Some makers in the 1980s started producing engines with either superchargers or turbochargers. Turbochargers and superchargers were not used that much on trucks but heavily on vans. Since vans we designed for on-road conditions and mostly delivery, they got the boost. Off road trucks could use the boost in power but due to dirty conditions and the chance of dirt in a turbo would provide disaster for the engine.

Vehicle Identification

One of the most highly requested questions we get at Yokohama Motors from overseas customers (remember, I'm in Japan) is what is my vehicle? What year is it? Is it a Suzuki or a Honda? Are parts interchangeable? Can I get parts from a Suzuki dealer in Kansas? After 30 years of questions I'm writing this book hoping to eliminate or at least lessen the amount of email requests.

VIN Plate

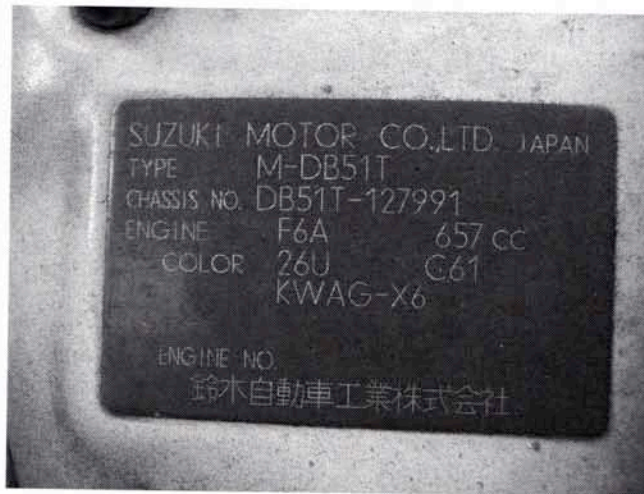

All Japanese vehicles have at least two ways to determine its identity. One is the standard VIN plate. Sometimes the VIN plate is attached by glue, screws, or rivets. If your plate is missing you will also find a permanent stamped VIN code on the body (Near or Under Drivers Seat).

VIN Stamp

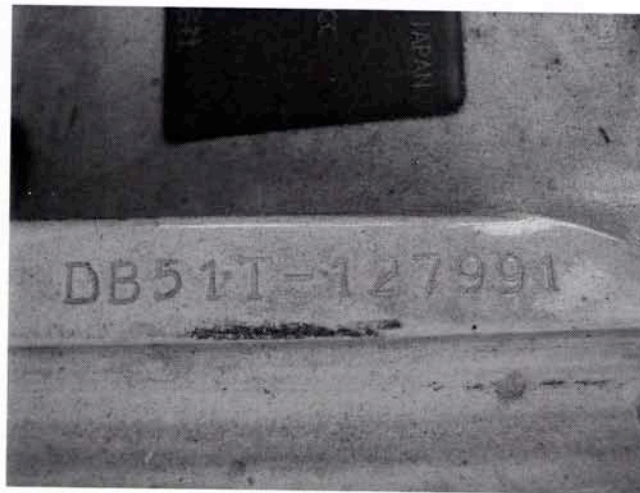

This body stamp just happens to be next to the ID plate. This is not always the case. It can be located almost anywhere as there is no set rule for this marking. Most common is under the driver's seat in the engine compartment or around the kick-panel on the passenger side. You will also notice that neither picture indicates the production year. That's because in Japan we don't specifically have a year! Totally confused now? A model year is not used, per say in

Japan. If I buy the same vehicle in December, 2007 it is a 2007. If I bought a car that was manufactured in 2006 and didn't register it until 2008 it is a 2008 car. To make it even more confusing, if I import a 1969 Camaro to Japan today and register it, it is a 2008 Camaro.

Instead of model years as the western world is used to, Japanese makers identify vehicles by code. The code will tell the parts supplier of mechanic everything about the vehicle. There is no room for error; for example between a 1996 or a 1997. We don't have a California or a New York version. A code tells all about the vehicle, period.

If you really want to know the vehicles manufactured year and you do not have a copy of the Japanese registration, look at the seatbelt tag. But remember, when ordering parts the year will have nothing to do with it.

Mistaken Identity

Note:* We have had people call for help and to their surprise found out their Suzuki was really a Mitsubishi! Not all vehicle name plates have English names on them! Use the chart below to correctly identify your truck!

Note* Japanese can spell names up to four different ways. Listed bellow is the most common.

Manufactures Names

□□ or □□□	Suzuki	□□ or □□□	Isuzu
□□□	Toyota	□□□ or □□	Honda
□□□□	Daihatsu	□□	Mitsubishi
□□ or □□□□	Nissan	□□□	Subaru
□□□	Mazda	□□□	Yamaha

Common Japanese terms on paperwork

□□□ (Shakenshou)	Title or registration
□□□□ (kabushikikaisha)	Corporation
□□□□ (shadaibangou)	VIN
□□ (nenshiki)	Year of manufacture- (Not model year)
□□ (katashiki)	Vehicle designation code(model)
□ (iro)	Color

Engine & Transmission Identification Location

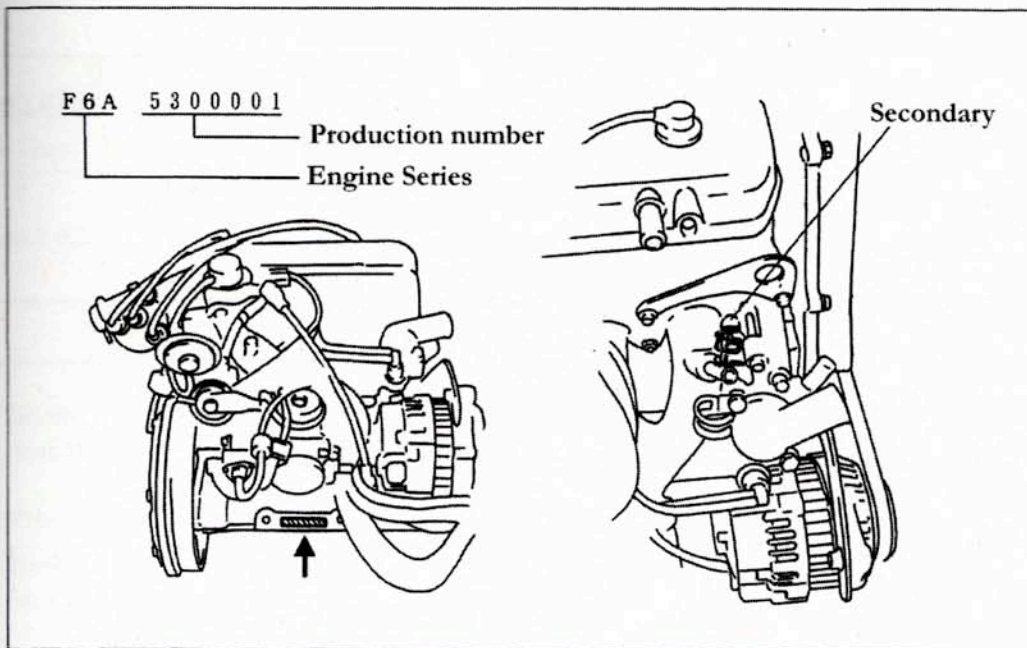

Automatic Transmission ID plate

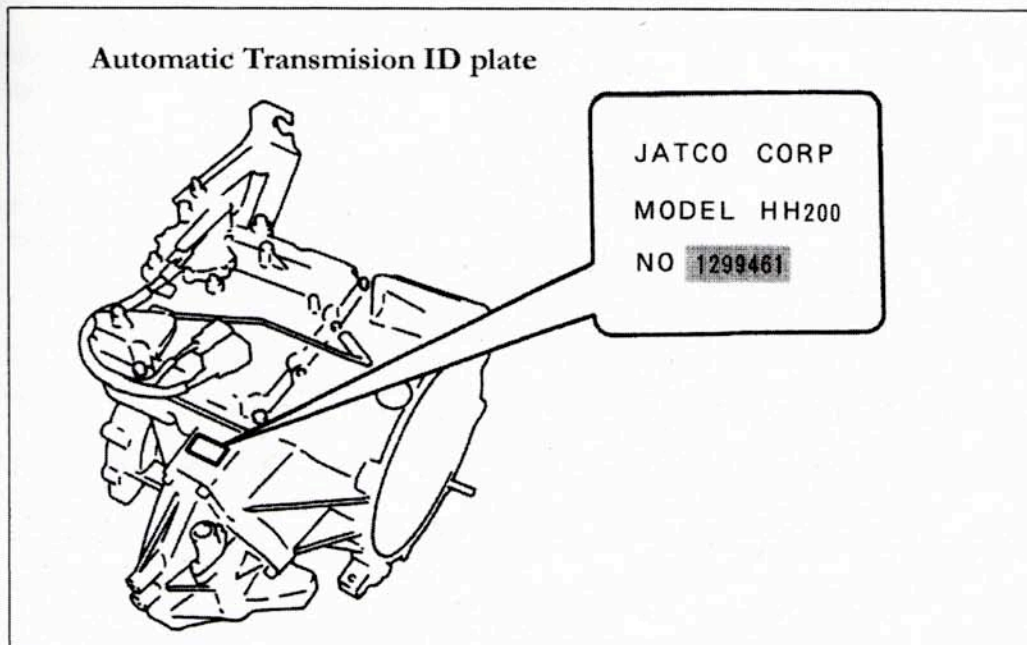

Service Data- Carry Truck and Every Van

Fuel Capacity (Liters)	Carry Truck 36L Every Van 37L	Conversion 1.0 Liter= 0.264 Gallon				
Engine Oil Requirements	Maximum 5000Km 3125 Miles	All Models 10W-30	Capacity			
			2.9 Liters			
Oil Filter Change 10,000 Km (Harsh conditions 2500Km)						
Transmission Oil	MT	2 Years or 20,000Km	Gear Oil #90 Suzuki (GL-4)	2WD	4 Speed 1.1Liter	
					5 Speed 1.2Liter	
				4WD	Part Time 2.6 Liter	
					Full Time 2.8 Liter	
	AT	2 Years or 40,000Km	Suzuki AT oil 5D06	Normal	Cp 2.6L	
				Turbo	Cp 2.8L	
Differential	2 Years or 20,000Km	75W-80 (GL-5)	2WD	Normal	1.0L	
				Turbo	1.3L	
			4WD	Front	0.7L	
				Part Time Rear	1.0L	
			4WD	Full Time	Front	0.7L
					Rear	1.3L

Spark Plug & Gap	Turbo	ND	W16EXR-U	GAP (Millimeters) 0.7 to 0.8mm
		NGK	BPR5E	
	Normal	ND	XU22EPR-U	0.8 to 0.9mm
		NGK	DCPR7E	

Battery	Normal	Part # 28B19R (Right positive connection)
	AC Equipped Also Refrigerated Trucks	Part # 38B20B







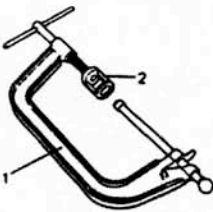

Ignition Timing

Carburetor Vehicles	Injection and Turbo Charged
Idle 950+-50 7 Degrees BTDC	Non-Turbo Idle 900+-50 Turbo Charged 950+-50 5 Degrees BTDC



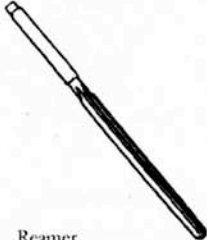



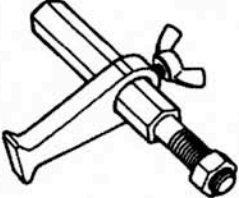

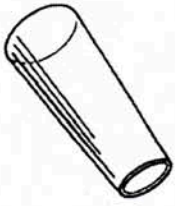
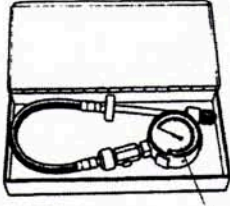

Note: See Vehicle Tag Mounted in Engine Room for Specific Details

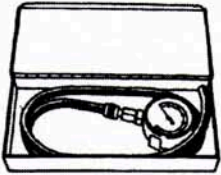
My Car Notes:

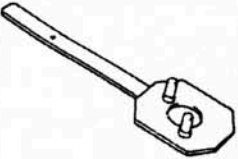
Suzuki Factory Tool Part Numbers

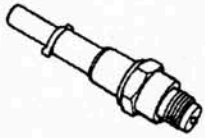
 <p style="text-align: center;">09915-47340 Oil Filter Wrench Socket</p>	 <p>1. 09916-14510 Compressor 2 Valve : 09916-48210 4 Valve : 09916-14910</p>	 <p>4 Valve : 09916-44310 2 Valve : 09916-44910 Valve Guide Remover</p>	 <p>4 Valve : 09916-57340 2 Valve : 09917-88230 Valve Guide Installer Socket</p>
 <p>4 Valve 09916-57330 Others 09916-58210 Valve Guide Installer</p>	 <p>Reamer 2 Valve 09916-38220(5.5mm) 4 Valve 09916-34570(5mm)</p>	 <p>Reamer 2 Valve 09916-38210(11mm) 4 Valve 09916-37320(10.5mm)</p>	 <p>09916-34541 Reamer Handle</p>
 <p>09916-77310 Spring Compressor</p>	 <p>09918-08210 Vacume Hose Joint</p>	 <p>09900-00410 Hexagon Wrench</p>	 <p>09924-17810 Flywheel Holder</p>

Suzuki Factory Tool Part Numbers

 <p>09926-18210 Oil Seal Guide</p>	 <p>09915-77310 Oil Pressure gage Set 1. Gage 09915-64510-001</p>	 <p>09915-77310 Oil Pressure Gage</p>	 <p>09915-67310 Vacume Gage</p>
 <p>09927-56020 Crankshaft Pulley Holder</p>	 <p>09917-68220 Camshaft Holder</p>	 <p>09915-64550 Compression gage 4Valve Attachment</p>	 <p>09915-64540 Compression gage 2Valve Attachment</p>
 <p>T-Box 10mm Wrench 09914-25550</p>	 <p>Compression Gage Hose 09915-64530</p>	 <p>Oil Pressure Gage Attachment 09915-78211</p>	

Frame Mount Diagram & Torque

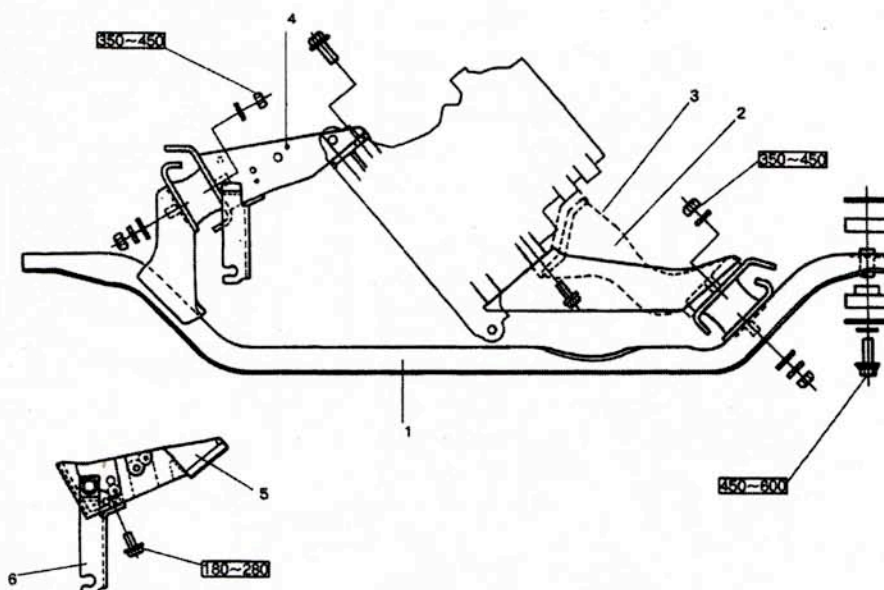

1. Front Mounting Member
2. Front Mounting Bracket Left (4WD)
3. Front Mounting Bracket Left (2WD)
4. Front Mounting Right Bracket (Truck)
5. Front Mounting Right Bracket (Van)
6. Clutch Cable Bracket (MT)

Box=Torque Spec (kg.cm)

Engine & Transmission Mounts

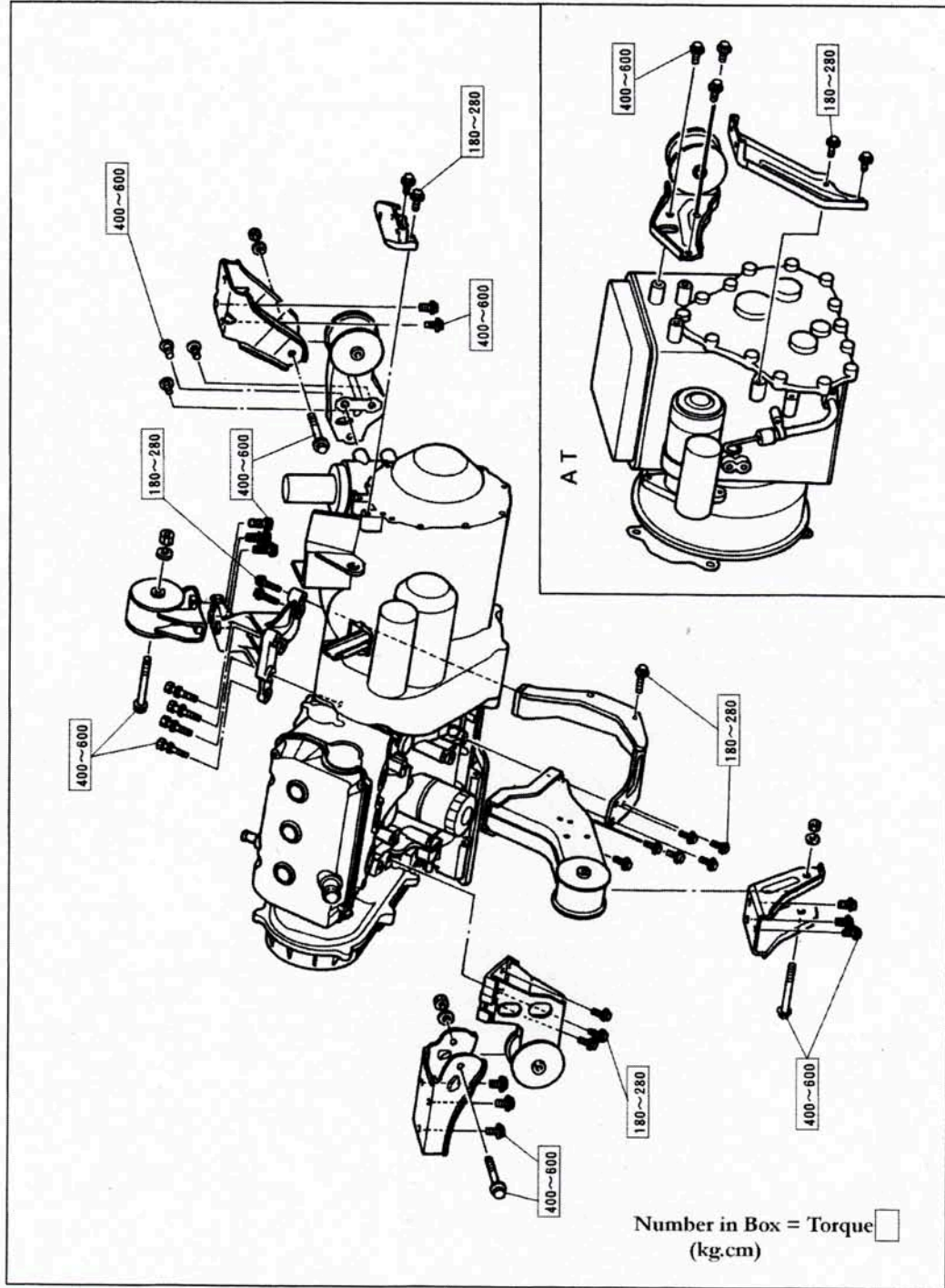

Engine Removal Truck 2WD & 4WD

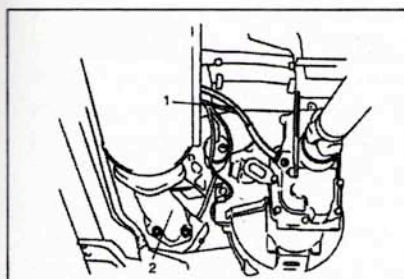
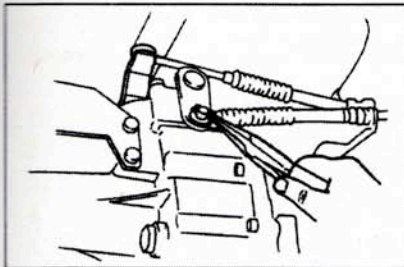
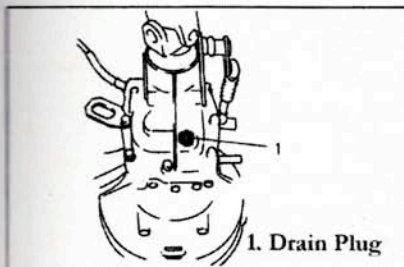
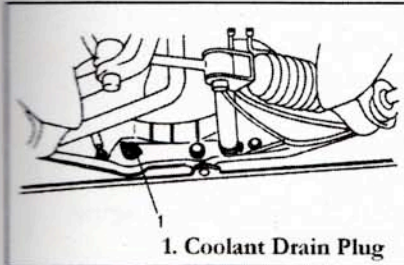

1. Remove Front Seat
2. Remove Front Door (Easy Access)
3. Remove Battery
4. Drain Coolant
5. Drain Transmission Oil
6. Disconnect Exhaust Pipe
7. Remove Rear Driveshaft
8. Remove Front Driveshaft (4WD)
9. Disconnect Clutch Cable (MT)
10. Disconnect shifter Connections
11. Disconnect Speedometer Cable
12. Disconnect Electrical Connections
13. Remove Heater Hoses
14. Remove Air Cleaner
15. Remove Air Duct
16. Disconnect Accelerator Cable
17. Disconnect Fuel Hose & Plug Line
18. Un-Bolt Mounts
20. Remove Engine

Engine Removal
 VAN 2 & 4WD
 AT-MT Versions

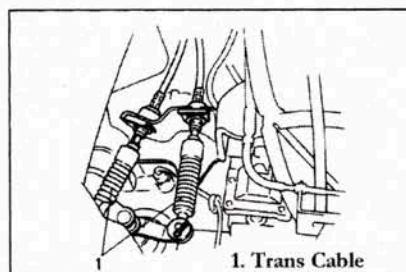
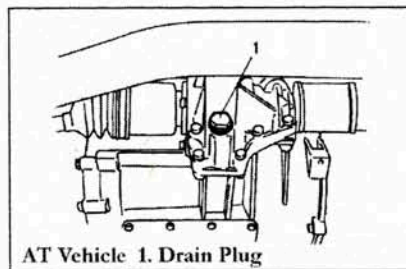
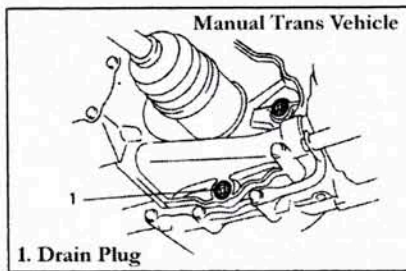
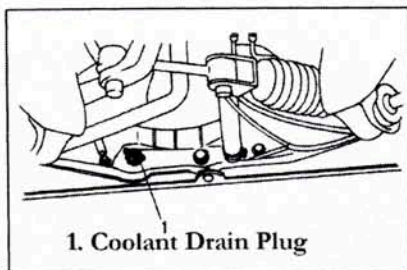

1. Remove Battery Connctions
2. Remove Engine Service Cover
3. Remove Rear Bumper
4. Drain Coolant System
5. Remove right-left wheel
6. Drain Transmission Oil
7. Disconnect Electrical Harness from Engine
8. Disconnect Speedometer Cable
9. Disonnect Accelerator Cable
10. Disconnect Transmission Cable
11. Disconnect Clutch Cable (MT Vehicle)
12. Remove Water Hose
13. Disconnect Vacume Hoses
14. Disconnect Fuel Hose
15. Remove (L-R) Brake Drum
16. Remove (L-R) Driveshaft hub
17. Disconnect Diveshaft connections
18. Disconnect Exhaust Center Pipe Bracket
19. Remove Front Drive Shaft (4WD Version)
20. Engine & Tranny Stiffiner
21. Remove Muffler
22. Remove Exhuast Center Pipe
23. Turbo-Charger Air Cleaner (If Equiped)
24. Remove Oil Filler Pipe (If Equiped)
25. Disconnect Tranny Mount
26. Remove Rear Engine Mounting Bracket
27. Unbolt Engine Front Mount
28. Unbolt Right Engine Mount
29. Remove Engine

Truck Carry

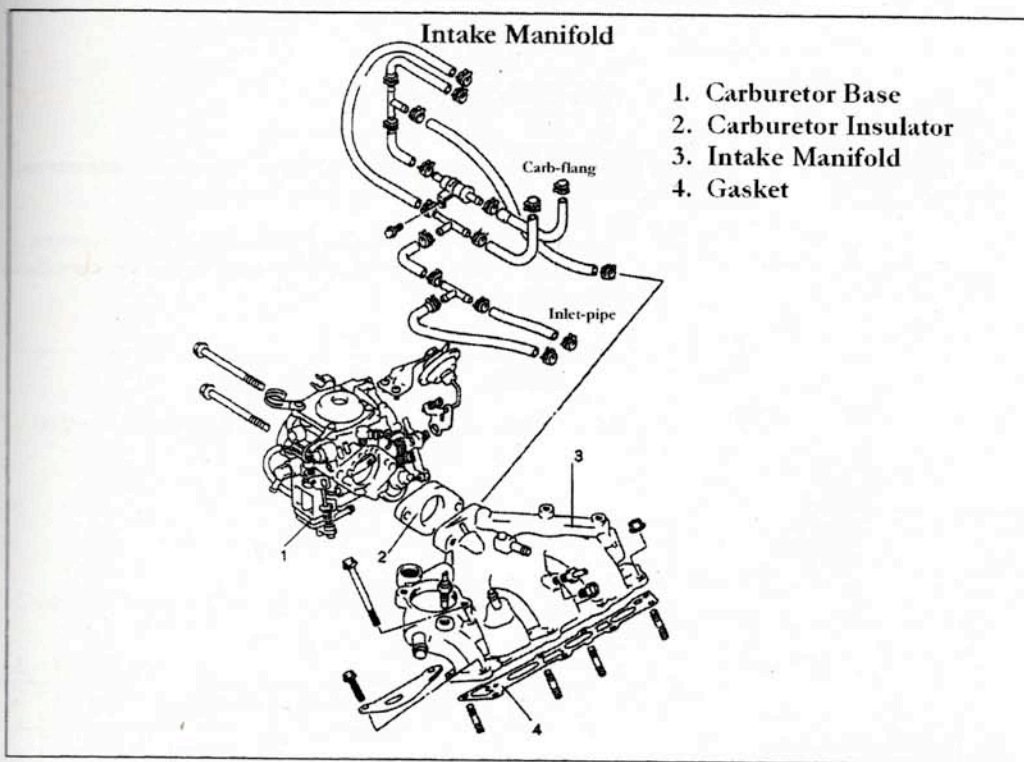

Remove or Disconnect the Following

1. Remove Front Seats
2. Remove Center Member and Side-Brake
3. Remove Air Cleaner
4. Drain Engine Coolant
5. Disconnect Carburetor Water Hose
6. Disconnect Carburetor Fuel Line
7. Disconnect Accelerator Cable
8. Disconnect Vacuum Hoses
9. Disconnect Electrical Connections
10. Disconnect and Remove Carburetor Assembly
11. Remove Manifold Attachment Bolts
12. Remove Intake Manifold

*Note: Use Only New Replacement Gaskets

Torque: Intake Manifold Bolts to (kg.cm) 180~280

Valve Lash (2 Valve)

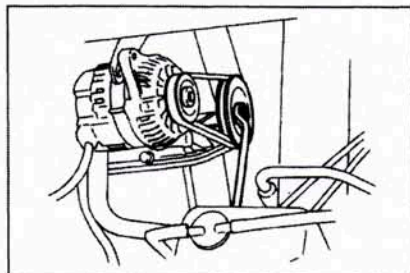

Valve Lash adjustment

2 Valve Engine

1. Remove Cylinder head valve cover
2. Rotate crankshaft to TDC position. Remove distributor cap and verify rotor bottom is facing #1 cylinder.
3. Using the chart below, use a feeler gage to slip between the adjustment screw and valve stem. Set to the specifications listed below.

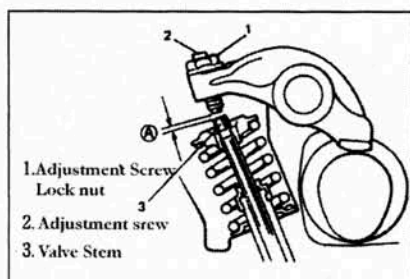

Note: Adjustment Screw Torque: (kg.cm) 150~200

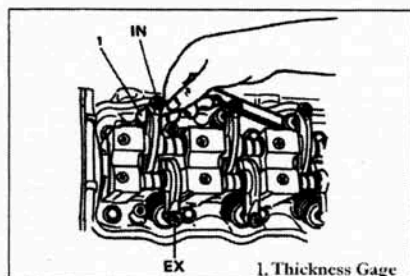

		Cylinder Number		
		1	2	3
Cylinder 1 TDC	I N	○	○	
	E X	○		○
Cylinder 1 Rotate the crank 1 turn	I N			○
	E X		○	

○ Circle mark = Time to adjust

Valve clearance measurements

Cold (mm)	I N	0.15
	E X	0.17
Hot (mm)	I N	0.25
	E X	0.27

4. Install a new valve cover gasket and install valve cover.
do not over tighten valve cover bolts
5. Set timing to specifications (see timing settings at the beginning of this book).
6. Test drive vehicle

Carburetor Intake Manifold VAN

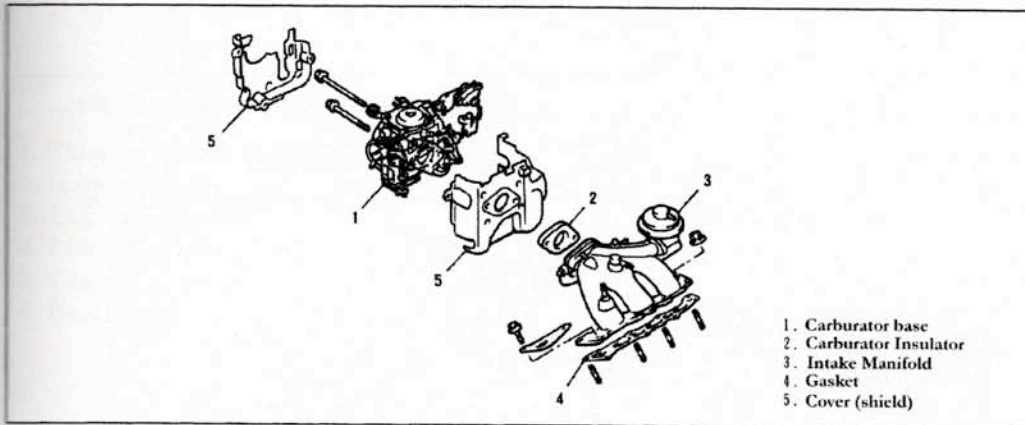

Caution: Never Drain Fluids While Hot. Always Drain Coolant at Outside Temperature

1. Drain Radiator
2. Remove Engine Service Cover
3. Remove Air Cleaner Assembly
4. Disconnect Electrical Connections
5. Remove Vacuum Hoses
6. Disconnect Accelerator Cable
7. Disconnect Fuel Lines and Plug
8. Remove Carburetor Cover
9. Disconnect Water Hose
10. Remove Carburetor Attachment Bolts and Remove Carburetor
11. Remove Intake Manifold Attachment Bolts and Remove Mainifold

Intake Manifold Torque: (kg.cm) 180~280

Note: Never Reuse Coolant

Exhaust Manifold

Truck

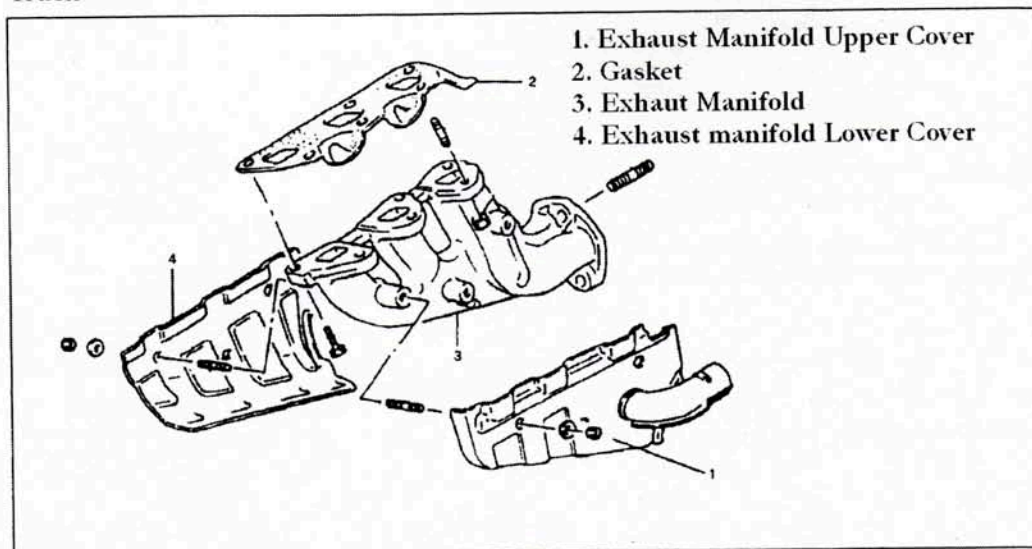

1. Remove Seat
2. Remove Air Cleaner Assembly
3. Remove Muffler
4. Remove Exhaust manifold Upper Cover
5. Remove Exhaust Manifold Lower Cover
6. Remove Exhaust Manifold Attachment Bolts
7. Remove Exhaust Manifold

Torque: Manifold Bolts (kg.cm) 180~200

Exhaust Manifold

Van

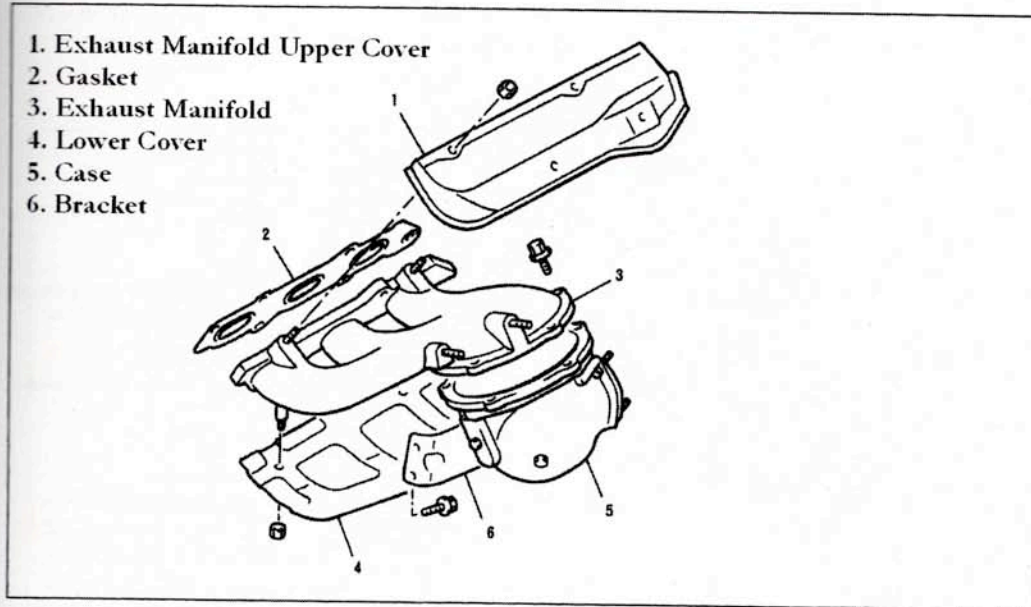

1. Jack Up Front of Vehicle
2. Remove Engine Service Cover
3. Remove Exhaust Manifold Upper Cover
4. Remove Exhaust Manifold Lower Cover
5. Remove Center Exhaust Pipe
6. Disconnect Sensor Coupler
7. Disconnect Bracket Attachment
8. Remove Manifold Attachment Bolts
9. Remove Manifold

Torque: Manifold Bolts (kg.cm) 100~200
Bracket Bolts (kg.cm) 180~280

Timing Belt & Tensioner Part Numbers

Timing Belt (4V)
FIG.14

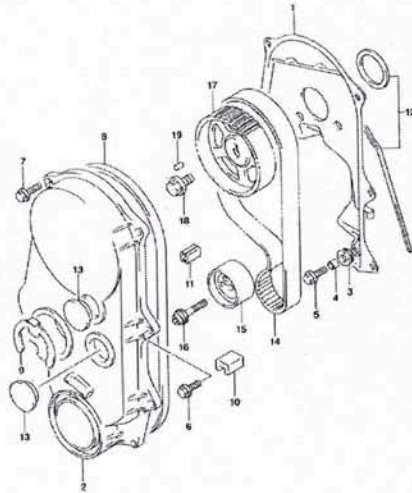

- | | |
|-----------------|---------------------------------|
| 1. 11360-79A00 | Cover: Timing Belt Inside |
| 2. 11390-77G01 | Cover: Outside |
| 3. 09308-10004 | Grommet |
| 4. 09180-06106 | Spacer 6.8x10x7 |
| 5. 09116-06167 | Bolt 6x20 |
| 6. 01550-06163 | Bolt |
| 7. 01550-06203 | Bolt |
| 8. 11396-77G00 | Seal: Timing Belt Cover-Outside |
| 9. 11397-76G00 | E-Ring: Timing Belt Cover |
| 10. 11394-77G00 | Seal |
| 11. 11394-70B00 | Seal |
| 12. 11480-77G00 | Seal Set: Timing Cover-Inside |
| 13. 09250-30017 | Cap: OD:36 |
| 14. 12761-79A00 | Belt: Timing |
| 15. 12810-76G00 | Tensioner |
| 16. 12815-76G00 | Bolt: Tensioner |
| 17. 12741-61D01 | Pulley: Camshaft Timing |
| 18. 01550-12253 | Bolt |
| 19. 09206-05001 | Pin |

Timing Belt (4V)

Timing Belt (Turbo)
FIG.15

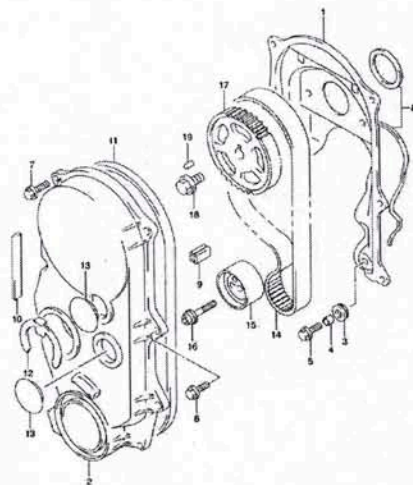

- | | |
|-----------------|------------------------------|
| 1. 11360-78A00 | Cover: Timing Belt-Inside |
| 2. 11390-76G01 | Cover: Outside |
| 3. 09308-10004 | Grommet |
| 4. 09180-06106 | Spacer: 6.8x8x10x7 |
| 5. 09116-06167 | Bolt 6x20 |
| 6. 01550-06163 | Bolt |
| 7. 01550-06203 | Bolt |
| 8. 11480-76G00 | Seal Set:Timing Cover-Inside |
| 9. 11394-70B00 | Seal |
| 10. 11395-76G00 | Seal |
| 11. 11396-76G00 | Seal |
| 12. 11397-76G00 | E Ring: Timing Cover |
| 13. 09250-30017 | Cap: OD:36 |
| 14. 12761-78A00 | Belt: Timing |
| 15. 12810-76G00 | Tensioner |
| 16. 12815-76G00 | Tensioner Bolt |
| 17. 12741-70D00 | Pulley: Camshaft Timing |
| 18. 01550-12253 | Bolt |
| 19. 09206-05001 | Pin |

Timing Belt (Turbo)

Timing Belt Tensioner

Van & Truck

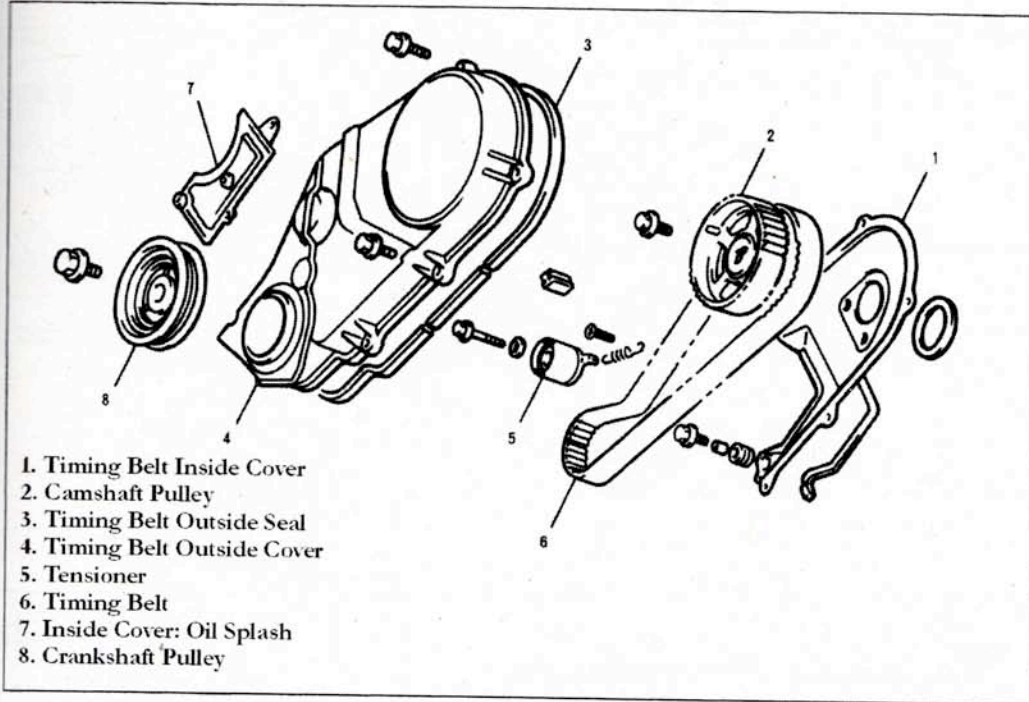

Note: Timing Belt Must be Changed Every 100,000 Kilometers (64,000 Miles)

Tensioner Replacement

1. Raise the Front of Vehicle. Place Jack Stands as recommended in this book
2. Remove Engine Service Cover
3. Remove Alternator Belt Outside Cover
4. Turn Crankshaft Pulley Over to TDC Position (Top Dead Center)
Note: Verify Distributor Rotor is Pointed to #1 Cylinder & Transmission Service Mark is Lined Up Through the View Hole.
5. Remove Alternator Belt
6. Remove Crankshaft Pulley
7. Remove Alternator Belt Inside Cover
8. Remove Timing Belt Outside Cover
9. Remove Tensioner and Inspect. If Over 50,000 Kilometers Replace. It is Not Recommended to Reuse Tensioner. If Tensioner Shows Damage Replace Timing Belt.

Note: It is Always Best Policy to Replace Tensioner & Timing Belt as a Set

Note: After Tensioner or Belt Replacement Always Adjust Valve Lash

Timing Belt Replacement

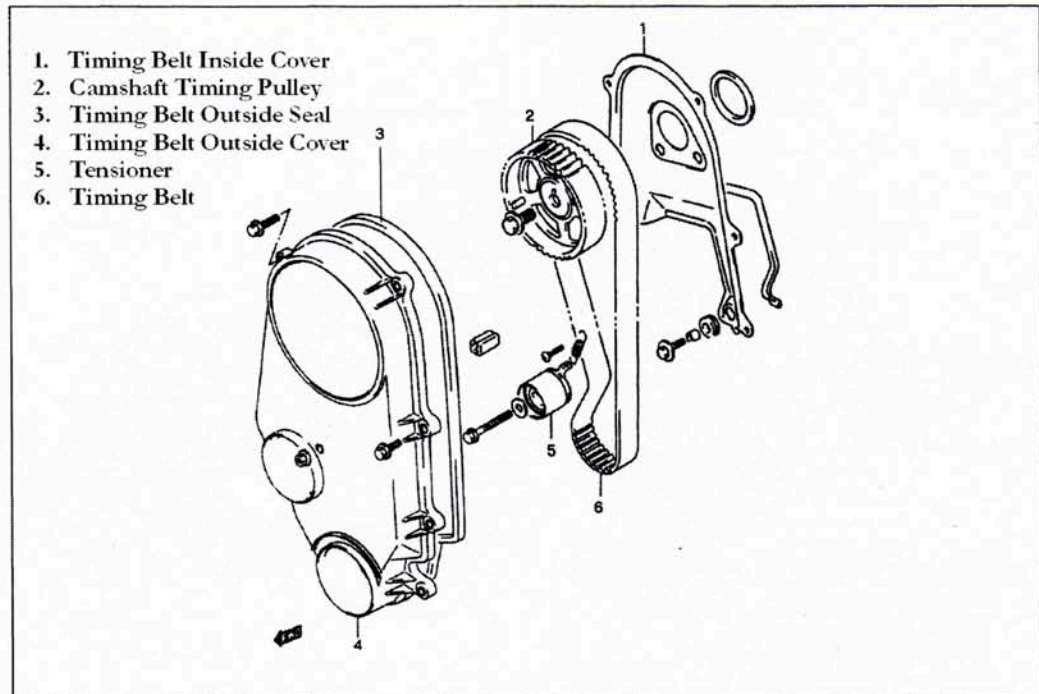

***Belt change every 100,000 Kilometers**

***If tensioner fails, always replace belt**

Timing Belt Replacement

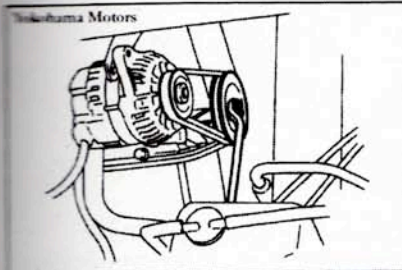

Procedure

1. Turn crank pulley until pointed to TDC
2. Remove crank pulley
3. Remove outside cover
4. Loosen tensioner
5. Remove old belt
6. Clean area
7. Inspect parts for damage or cracks (replace if damaged)

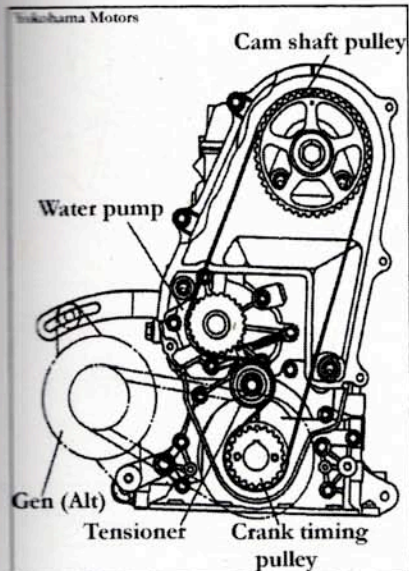

Service Point

- * Check tensioner for free spin. Any resistance replace*

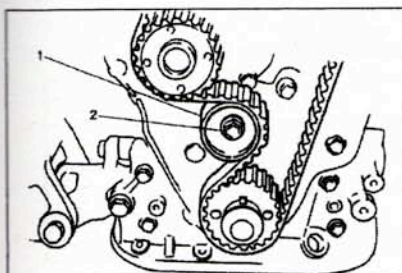

1. Tensioner
2. Tensioner bolt

8. Install Reverse Procedure
9. Run Engine 5~10 at Variable Speeds
10. Check Timing Settings
11. Check Valve Lash

Valve Lash (2 Valve)

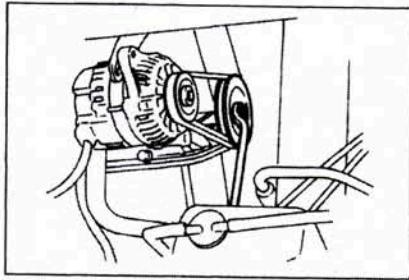

Valve Lash adjustment

2 Valve Engine

1. Remove Cylinder head valve cover
2. Rotate crankshaft to TDC position. Remove distributor cap and verify rotor bottom is facing #1 cylinder.
3. Using the chart below, use a feeler gage to slip between the adjustment screw and valve stem. Set to the specifications listed below.

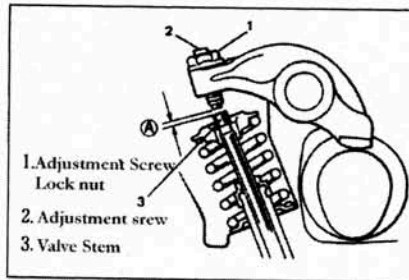

Note: Adjustment Screw Torque: (kg.cm) 150~200

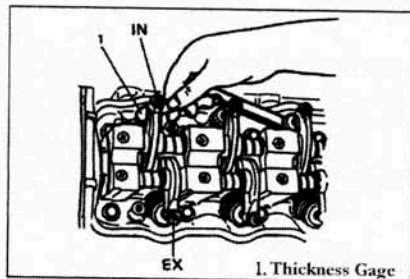

		Cylinder Number		
		1	2	3
Cylinder 1 TDC	I N	○	○	
	E X	○		○
Cylinder 1 Rotate the crank 1 turn	I N			○
	E X		○	

○ Circle mark = Time to adjust

Valve clearance measurements

Cold (mm)	I N	0.15
	E X	0.17
Hot (mm)	I N	0.25
	E X	0.27

4. Install a new valve cover gasket and install valve cover.
do not over tighten valve cover bolts
5. Set timing to specifications (see timing settings at the beginning of this book).
6. Test drive vehicle

Valve Lash (4 Valve)

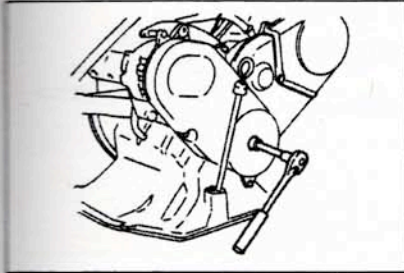

Valve lash adjustment

4 Valve

1. Remove Cylinder head valve cover
2. Rotate cranshaft to TDC position. Remove distributor car and verify rotor buton is facing #1 cylinder
3. Using the chart below, use a feeler gage to slip between the adjustment screw and valve stem. Set to the specifications listed below.

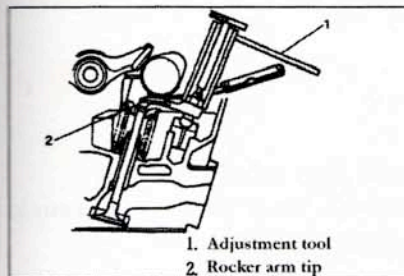
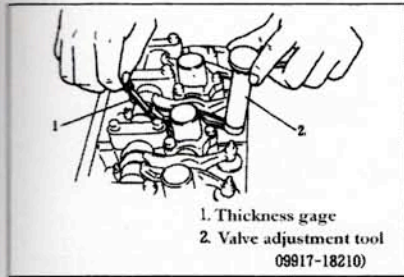

Cylinder Number		1	2	3
Cylinder #1 TDC	I N	○	○	
	E X	○		○
Cylinder #1 Rotate the crank 1 turn	I N			○
	E X		○	

○ Circle mark=Time to adjust

Cold (mm)	I N	0,08
	E X	0,10
Hot (mm)	I N	0,12
	E X	0,12

Adjustment screw lock nut torque (kg.cm) 100 to 130

Engine Oil

Engine Oil Level

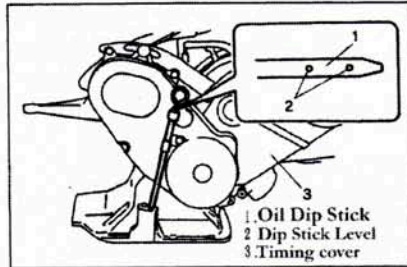

1. Remove dip stick and check level.
Level should be between the dots
2. If clean, add oil to proper level.

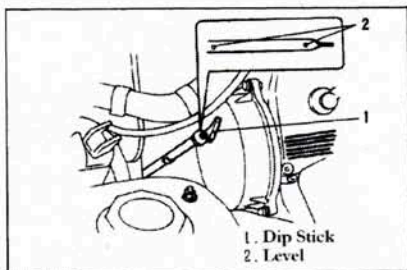

Oil Change

1. Remove drain plug from oil pan.
2. Inspect oil for contaminants, if clean replace plug.

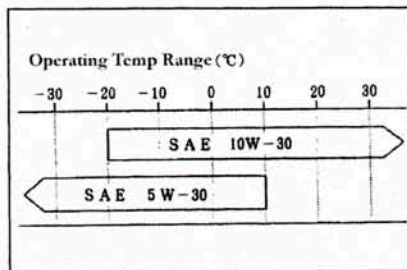

3. Fill oil to proper capacity with recommended oil from the temperature chart. Verify level with dip stick.

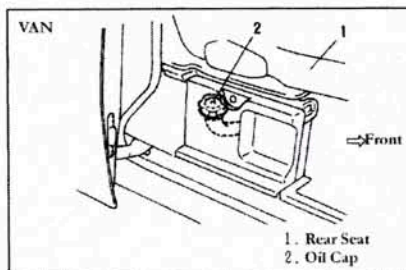

Oil Capacity 2.3 Liter
Check vehicle specifications chart

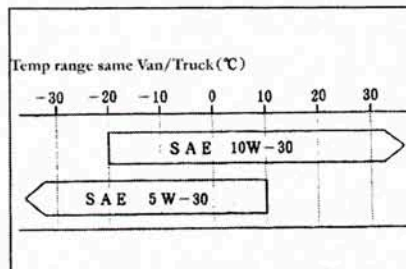

Engine Oil Pressure Test

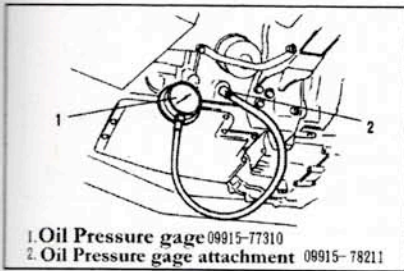
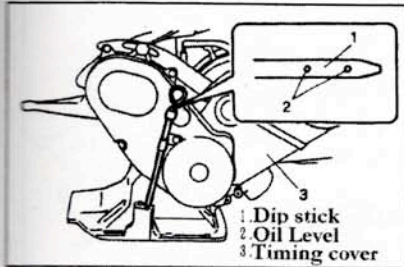

Part # for gage & Adapter is Suzuki Equipement

Oil Presure

VAN

Caution: Make sure to check oil level is correct!

- Check oil level
add if necessary
 - Make sure oil is clean
Change before test if dirty.
- If contaminants such as metal shavings are found, damage will occure to test equipment. At this point recomended to disassemble engine for inspection.

1. Remove plug from cylinder block as shown.

2. Attach gage and adapter as shown

3. Start engine and run to operating temperature.

4. Operating temp 90°C~100°C

Run engine to 4000RPM. Presure range below.

Oil Pressure
(kg/cm) : Turbo 3.3 ~ 4.3
Non-Turbo 2.7 ~ 3.7

5. Remove gage and adapter. Use new silicon tape on plug and torque to specification bellow.

6. Start engine and inspect for leaks.

Plug torque (kg · cm) : 120~150

Pressure out of range: Replace pump and repeat procedure.

Oil Pump Parts

Oil Pump (All)

FIG.31

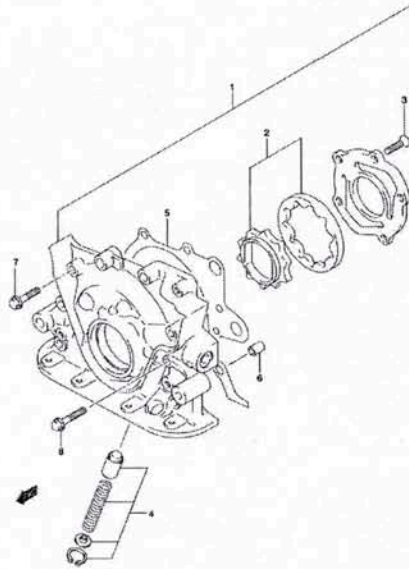

- | | | |
|----|-------------|-----------------------|
| 1. | 16100-76820 | Oil Pump Set |
| 2. | 16130-70B01 | Rotor Set |
| 3. | 02122-06163 | Screw |
| 4. | 16150-60A00 | Relief Valve Set |
| 5. | 16119-76G00 | Gasket: Oil Pump Case |
| 6. | 04211-09109 | Pin |
| 7. | 01550-06303 | Bolt |
| 8. | 01550-06353 | Bolt |

Oil Pump (All)

Oil Pump

Procedure

1. Remove the following
Crank pulley, outside cover, timing belt tensioner,
timing belt. *more information see "Timing belt removal".

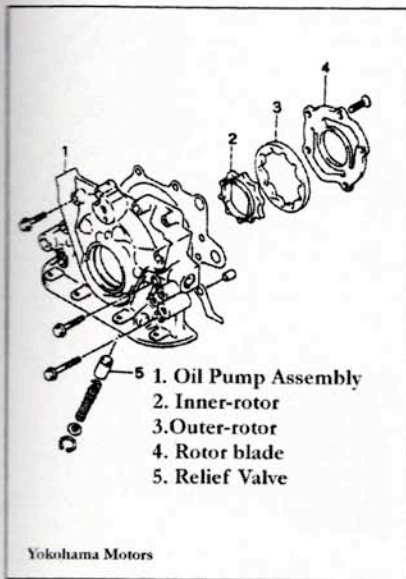

Remove

2. Timing belt pulley
3. Engine front mounts
4. Oil pan
5. Oil strainer

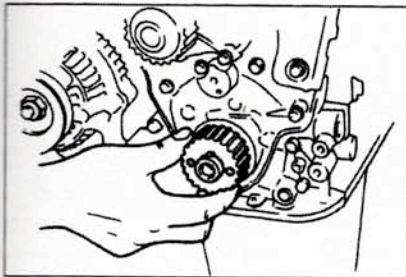

6. Remove the oil pump bolts (10).
7. Carefully remove assembly

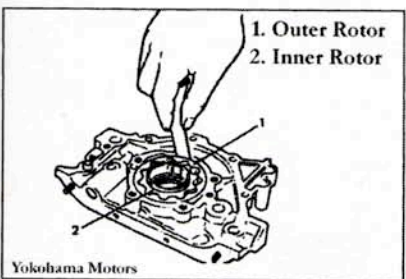
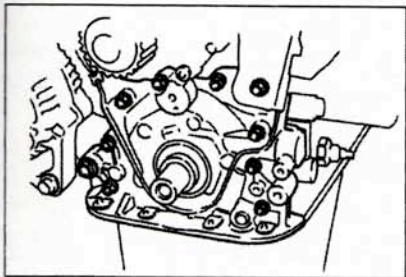

Pump Clearance Check

Outer rotor to case clearance must be below
0.13 (mm).

Replace if clearance is out of range

Oil Pump

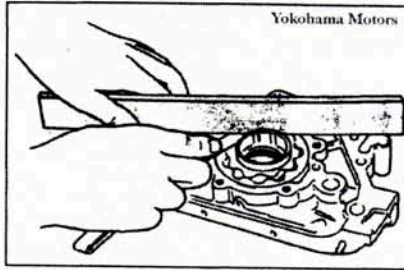

Side Clearence

Measure side clearence.
Side clearence must be below 0.15(mm)

Out of range replace

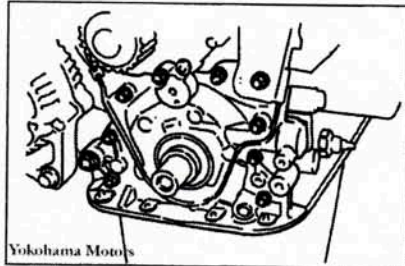
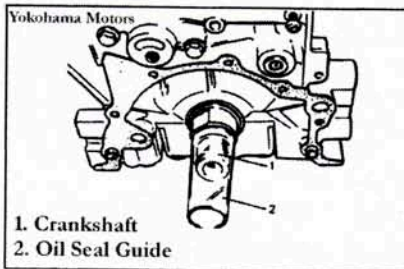

Attach oil pump ***Do not over torque***

Torque bolts to (kg.cm) 90-120

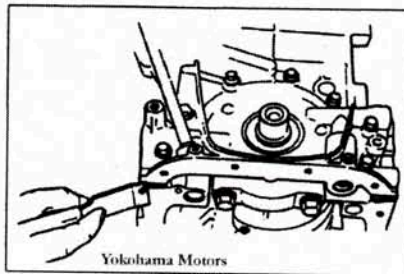

Oil Pump Gasket

Make sure all of the old gasket has been removed and surface is clean before installing new gasket

Re-assemble timing cover assembly

Always fill engine with new oil

Run engine a check oil pressure (begining of chapter)

Oil Pan & Strainer

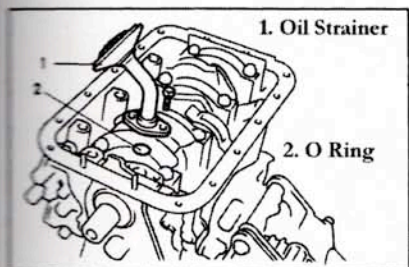

When ever removing or replacing the oil strainer always replace the O Ring. Before installing the O Ring, coat with clean engine oil.

Oil Strainer torque (kg.cm) 90-120

Type 1

Oil Pan Gasket. Apply High Temp Gasket Sealer

Note: Make sure all surfaces are oil free before applying sealant

Suzuki Sealant Part#1207C 99000-31150

Oil Pan Torque (kg.cm) 90-120

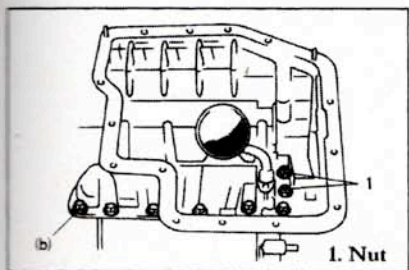
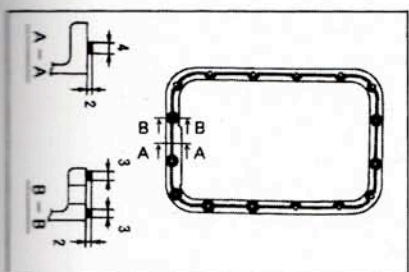

Type 2

Oil Pan Gasket. Apply High Temp Gasket Sealer

Note: Make sure all surfaces are oil free before applying sealant

Suzuki Sealant Part#1207C 99000-31150

Oil Pan Torque (kg.cm) 90-120

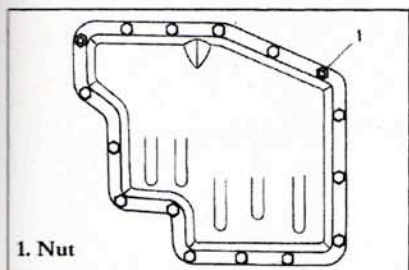
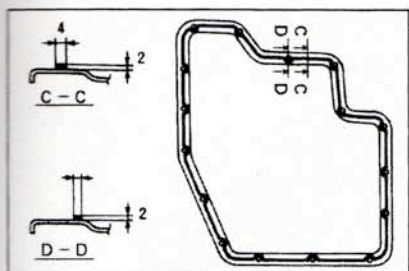

Cylinder Head, Camshaft, Valve, Rocker Arm

2 Valve Head

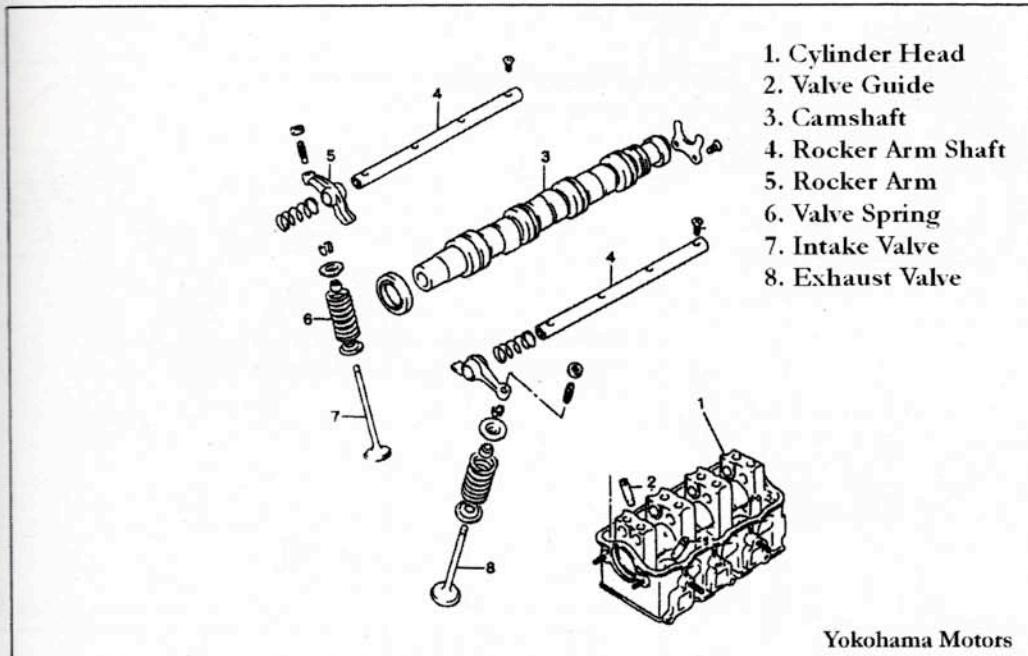

Disassemble-Disconnect-Remove The Following

1. Remove front seat
2. Disconnect negative (-) battery cable
3. Remove Engine service cover
4. Drain coolant system
5. Remove air cleaner case
6. Remove water pump
7. Disconnect fuel hose
8. Disconnect vacume hoses
9. Disconnect accelerator cable
10. Disconnect wiring
11. Remove timing belt (see previous)
12. Remove cam shaft pulley
13. Disconnect exhaust pipe and Manifold
14. *If equipped Turbo attachments*
15. Remove distributor
16. Remove valve cover
17. Remove cylinder head bolts (8)
18. Remove cylinder head

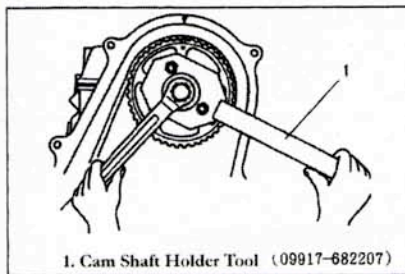

Cylinder Head (2-Valve)

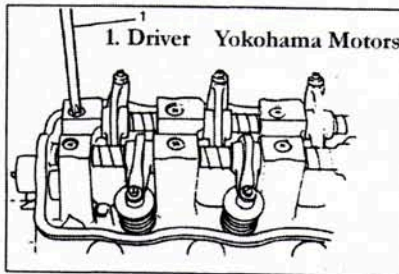

1. Remove Rocker Arm Shafts Screws

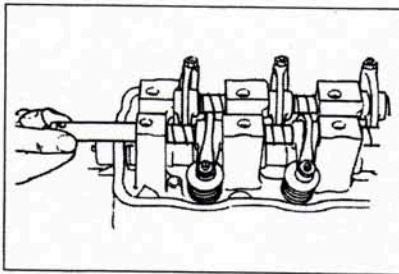

2. Remove intake and exhaust rocker arm shaft, then remove rocker arm shaft springs

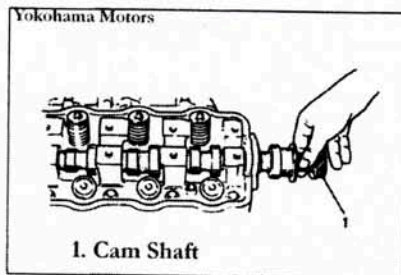

3. Carefully slide out cam shaft

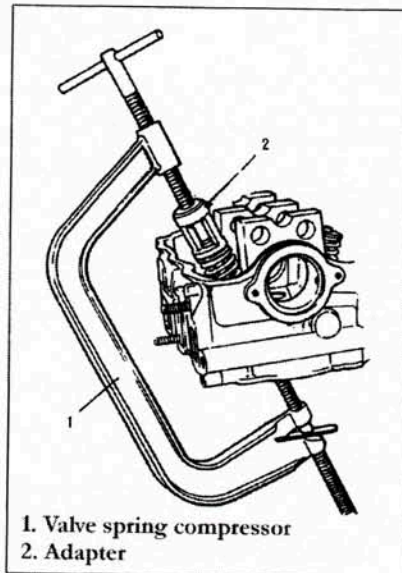

4. Using a valve spring compressor remove springs

note-lable springs from original location

*Caution-never hit sticky springs with a steel hammer
use only soft brass head hammer*

Cylinder Head (2-Valve)

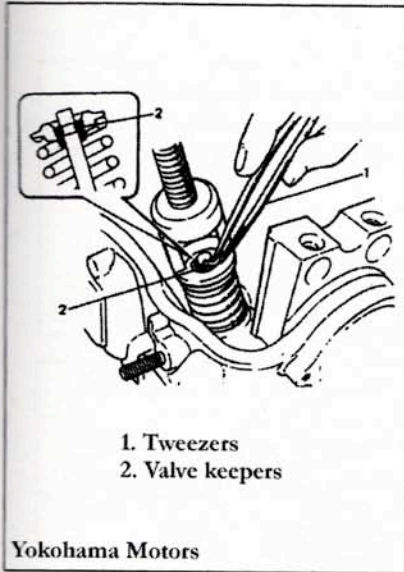

Caution- Springs under extream pressure, use saftey glasses when removing springs

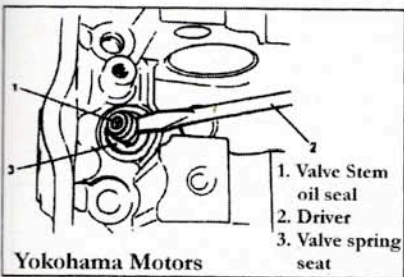

7. Remove valve lifter, spring retainer, valve spring
8. Remove valve
9. Remove valve stem oil seal, next remove valve spring seat

Caution- Never re-use oil seals!

Note-if valve guides must be removed use Suzuki tool number (09916-44910)

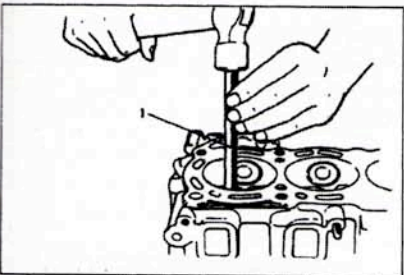

Inspection

Using a micrometer check the cam hight. If it is out of spec replace camshaft

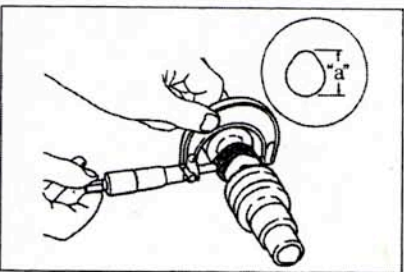

Cam Hight "a"	Acceptable	Limit
Intake cam (mm)	30.74	30.6
Exhaust cam (mm)	29.75	29.6

Cylinder Head (2-Valve)

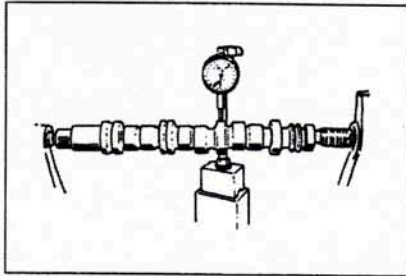

Camshaft Straightness Measurement

Use a dial indicator to measure for straightness rotate the camshaft and observe the reading

Reading must not exceed 0.10(mm)

If over the limits replace camshaft

Camshaft Journal

*To determine the amount of out-of-round, measure each journal in two different directions and compare to specifications

*Also check for journal taper by measuring at each end of the journal

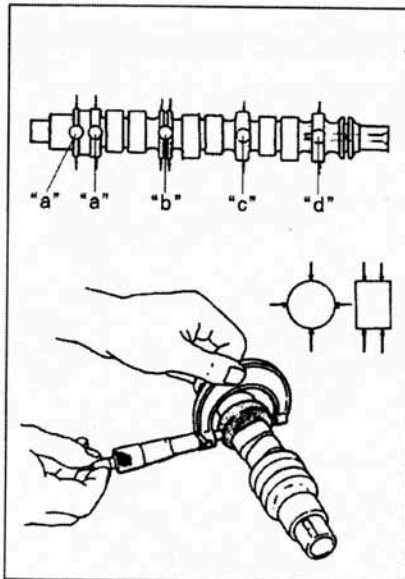

Journal limits: Within limits 0.050-0.091

Replace 0.15

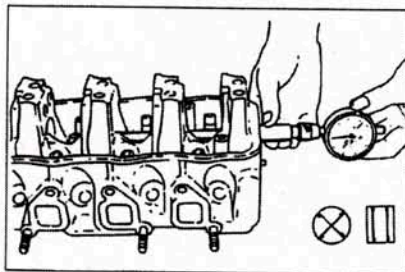

		Camshaft Outside (mm) Diameter	Cylinder Head Diameter (mm)
"a"	Normal	43.425~43.450	43.500~43.516
	Limit	43.375	43.525
"b"	Normal	43.625~43.650	43.700~43.716
	Limit	43.575	43.725
"c"	Normal	43.825~43.850	43.900~43.916
	Limit	43.755	43.915
"d"	Normal	44.205~44.050	44.100~44.116
	Limit	43.975	44.125

Cylinder Head (2-Valve)

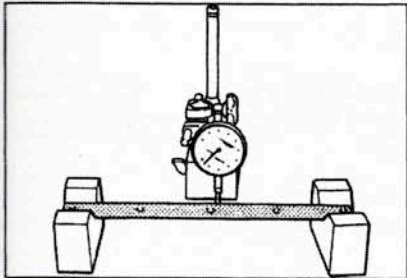

Rocker Arm Shaft Inspection

Use a dial gage to check diameter for warp age

*Maximum allowance 0.12 (mm)

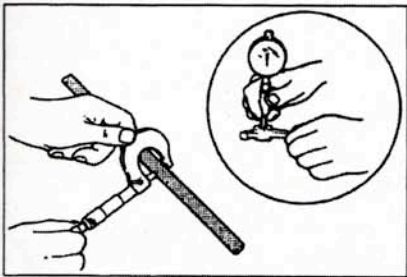

Roker Arm and Roker Arm Shaft Clearance

Rocker Arm and Shaft clearance

Allowance 0.005-0.040

Replace 0.06

Valve Stem & Guide Measurements

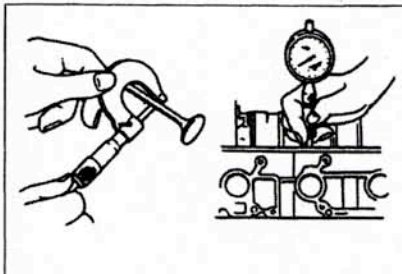

		Allowance	Limit
Valve Stem outer Diameter (mm)	I N	5.465~5.480	—
	E X	5.450~5.465	—
Valve Guide Inside Diameter (mm)	I N	5.500~5.512	5.54
	E X	5.500~5.512	5.54
Stem & Guide Clearance (mm)	I N	0.020~0.050	0.07
	E X	0.035~0.065	0.09

Cylinder Head (2-Valve)

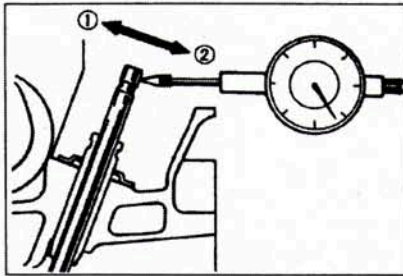

If a bore gage is not available, it is possible to use a dial gage. Use the diagram to the right as an example.

If the play between the stem and the guide are outside the range below. Replace valve guide.

IN 0.14
EX 0.18

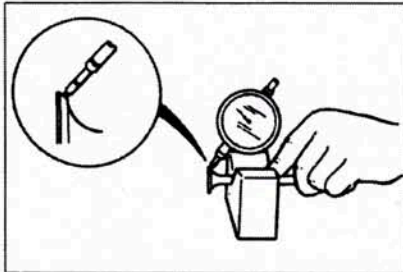

Place a Valve in a V block, and using a dial gage rotate valve.

Maximum allowance: 0.08 (mm)

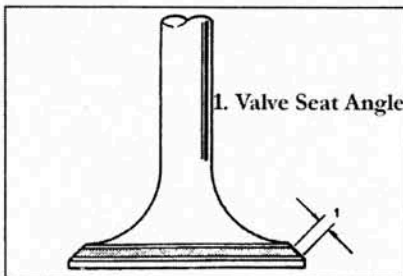

Valve to Valve Seat face

IN 1.3-1.5(mm)
EX 1.3-1.5(mm)

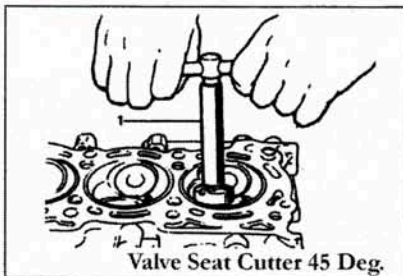

*Use extreme caution when cutting valve seats. It is recommended to start with a small cutter and work up to a larger cutter. Finally with 45 degree cutter. It is recommended to take the head to a machine shop for this operation. Over-cutting can cause serious damage to the head.

Cylinder Head (2-Valve)

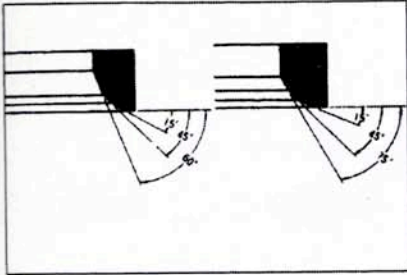

Valve Lap Degree Diagram

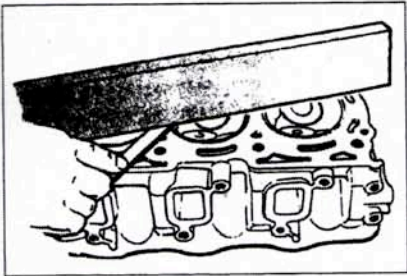

Cylinder Head Plane

Use a straight edge bar and a feeler gage

Allowance 0.05(mm)

Over range, have head machined to spec

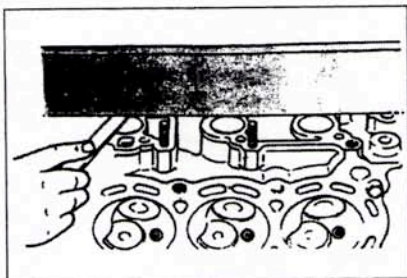

Manifold Face (Cylinder Head)

Use a straight edge bar and a feeler gage.

Allowance 0.10(mm)

Out of range, have face milled at a machine shop

Cylinder Head (2-Valve)

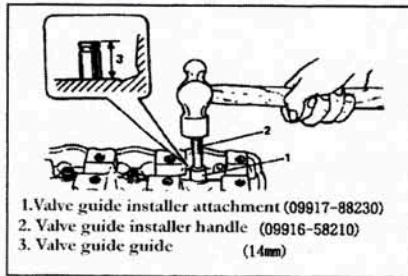
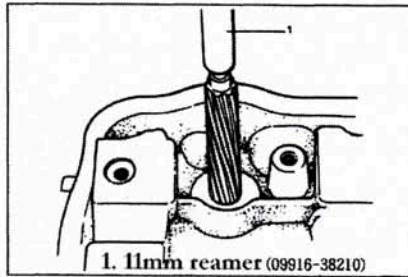

Assembly

1. Before installation of new valve guides use a 11mm reamer.

2. Pre-heat cylinder head to 80-100 Degrees Celcius
Use the proper tools as displayed in the box to the left. Install guides.

Note-if a guide has been removed for any reason it must be replaced with a new guide.

Oversize Guides (mm) 0.03

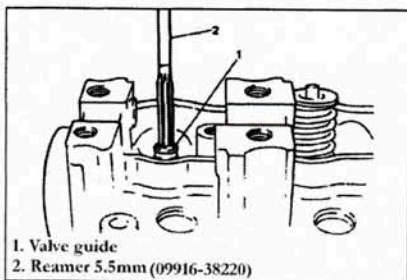

3. After installation, use a 5.5(mm) reamer to verify size.
4. Next place valve spring in place
5. Install new valve stem oil seal

*Note-lubricate new seals with clean engine oil

Cylinder Head (2-Valve)

Assembly

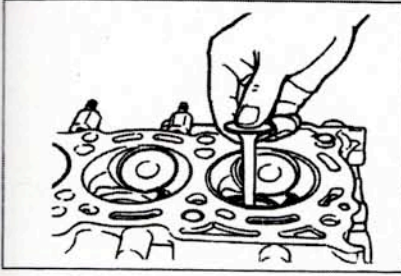

6. Lubricate valve with engine oil and slide into guide. Make sure guide slides without restriction.

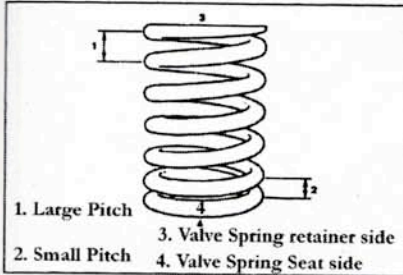

7. See chart on left for proper spring seating

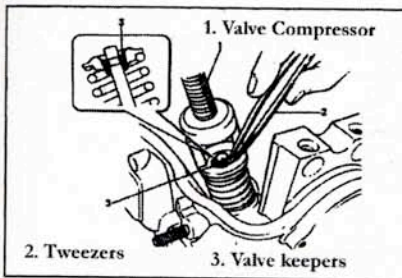

8. Using a valve compressor, install valve keepers

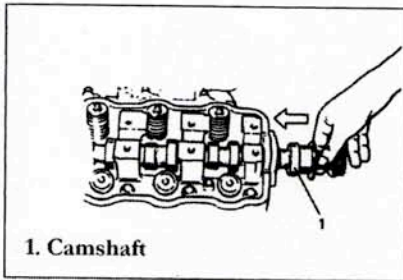

9. Heavily lubricate camshaft with engine oil and install

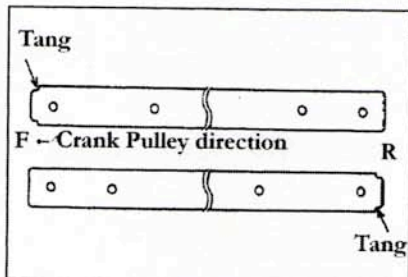

10. Install rocker arm shaft. Make sure tang is in the correct direction as noted in the diagram on the left.

Cylinder Head (2-Valve)

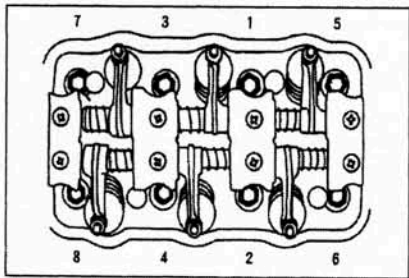
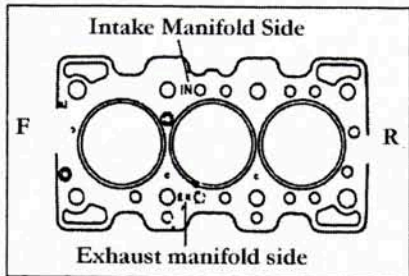

Assembly

Install new head gasket. Follow the diagram on the left for guidance.

Do not use sealant

Make sure all surfaces are clean

Install head assembly

Torque to (kg.cm) 550-600

Follow torque sequence on the chart to the left

Assemble remaining parts as in previous section of this chapter.

Cylinder Head (4-Valve)

Yokohama Motors

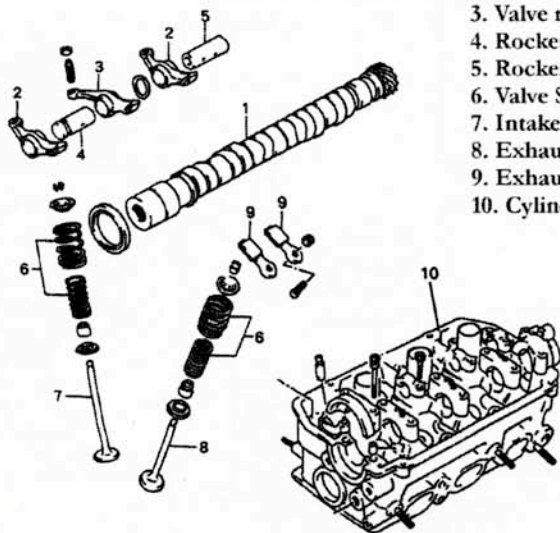

1. Camshaft
2. Valve rocker intake No. 1 Arm
3. Valve rocker intake No.2 Arm
4. Rocker Arm No.1 Shaft
5. Rocker Arm No.2 Shaft
6. Valve Spring Set
7. Intake Valve
8. Exhaust Valve
9. Exhaust Valve Roker Arm
10. Cylinder Head

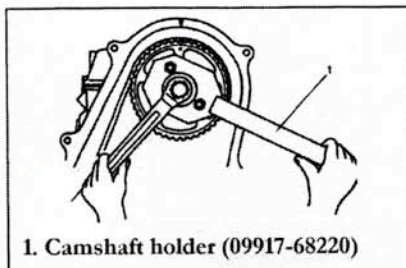

1. Camshaft holder (09917-68220)

Revomal

1. Drain coolant system
2. Remove service cover
3. Reome air cleaner case
4. Remove water hose
5. Disconnect vacum hoses
6. Disconnect fuel hose
7. Disconnect accelerator cable
8. Remove timing belt (see previous steps)
9. Disconnect Electrical connectors
10. Remove camshaft timing pulley
11. Remove timing belt inside cover
12. Remove exhaust center pipe
13. Remove exhaust manifold
14. Remove cylinder head

Cylinder Head (4-Valve)

Disassembly

Remove Rocker Arm Shaft

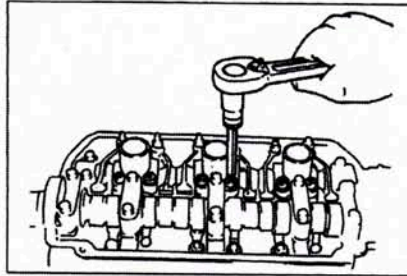

Remove
Intake Rocker Arm
Camshaft Caps
Camshaft

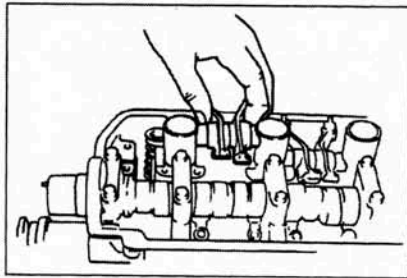

Remove Cylinder head Bolts (8)
Remove Cylinder Head

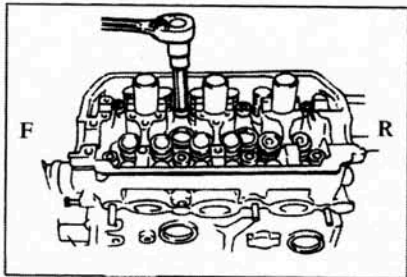

Using a spring compressor remove valves
*Spring under extreme pressure, always
use proper safety glasses*

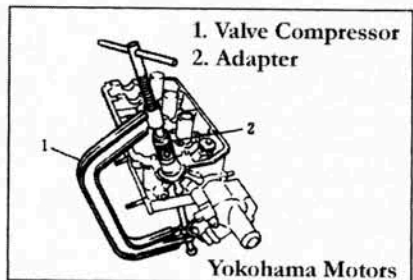

Cylinder Head (4-Valve)

Inspection

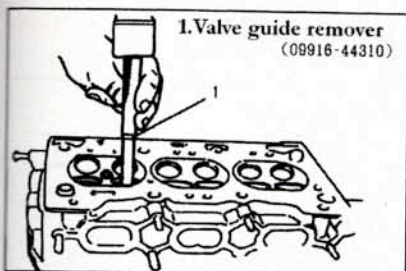

Using an appropriate tool, remove valve guides
Note-Never re-use valve guides

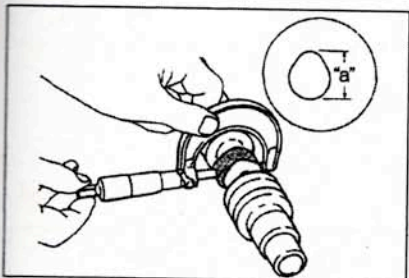

Cam Hight " a "	Allowance	Limit
Intake Cam (mm)	30.74	30.6
Exhaust Cam (mm)	30.20	30.1

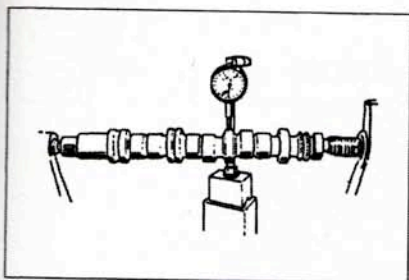

Camshaft Warp Age

Using a dial gage, check the camshaft

Allowance: Below 0.10 (mm)

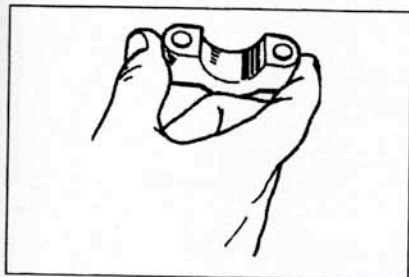

Check the camshaft housing caps for scratches, etc.
If visable damage exists-replace

Cylinder Head (4-Valve)

Inspection

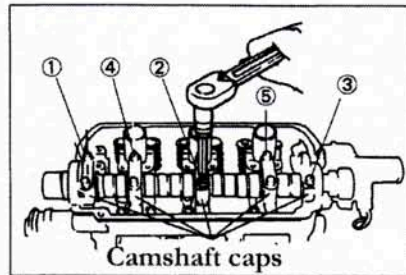

Re-insert camshaft into head and torque caps
Torque (kg.cm) 90-100
Make sure camshaft is well oiled

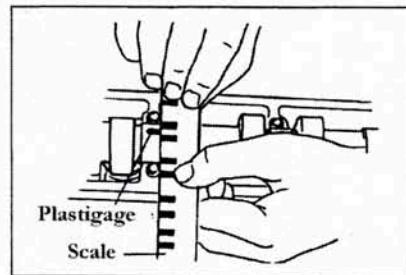

Using Plastigage, check clearance

Allowance 0.045-0.087(mm)
Limit 0.12(mm)

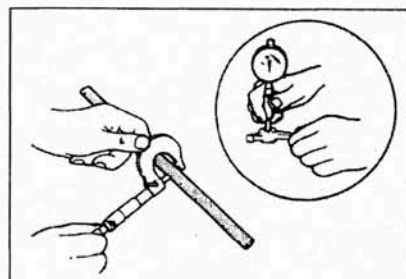
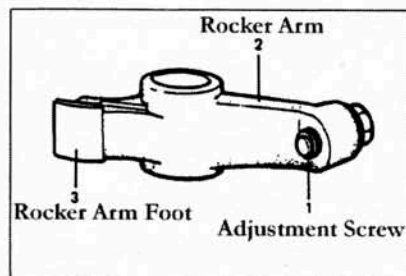

Rocker Arm Shaft Clearance

Allowance 0.005-0.040(mm)
Limit 0.006(mm)

Cylinder Head (4-Valve)

Valve Inspection

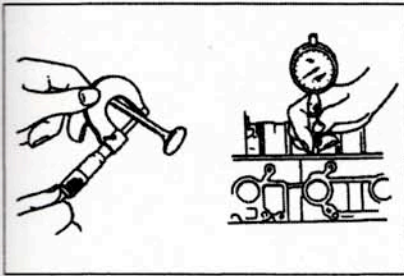

		(mm) Allowance	(mm) Limit
Valve Stem Diameter	I N	4.965~4.980	-
	E X	4.950~4.965	-
Valve Guide Inner-Dia	I N	5.000~5.012	5.04
	E X	5.000~5.012	5.04
Stem Guide	I N	0.020~0.047	0.07
	E X	0.035~0.062	0.09

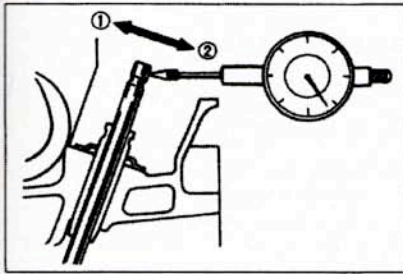

If a bore gage is not available, use a dial gage as in the example to the left

Limit= I N 0.14(mm)
EX 0.18(mm)

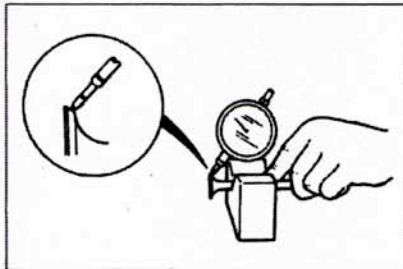

Using a V-Block and a dial gage check valve face

Limit= 0.08(mm)

Cylinder Head (4-Valve)

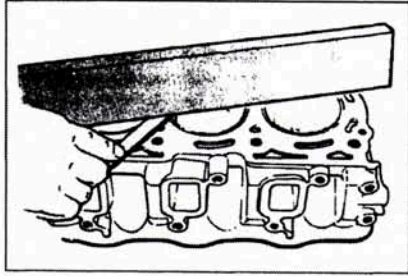

Surfaces

Using a straight edge and a feeler gage,
check surface clearance

Allowance 0.05(mm)

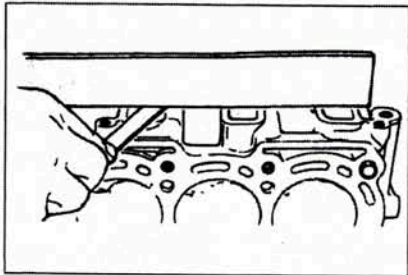

Using a straight edge check clearance

Manifold Face: Allowance 0.10(mm)

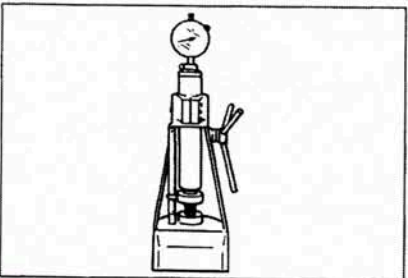
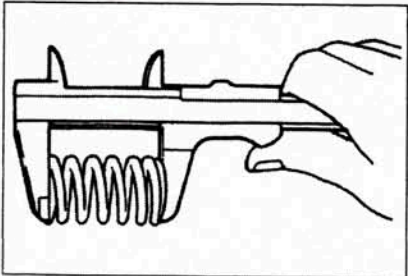

Valve Spring Chart

		Allowance	Limit
Valve Spring(mm)	Inner	32.9	31.8
	Outer	36.6	35.5
Valve Spring Pressure (kg/41.5mm)		24.8~29.2	22.8

Cylinder Head (4-Valve)

Assembly

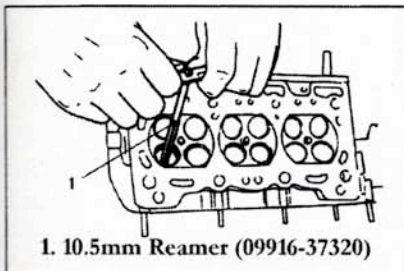

Using a 10.5(mm) reamer, ream out guide holes

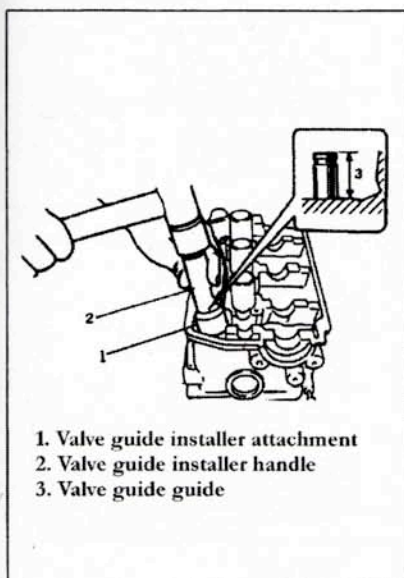

Warm cylinder head to between 80-100 degrees Celsius.

Use proper valve guide installation tools

Note-Never re-use valve guides

Maximum oversize guide use: 0.03(mm)

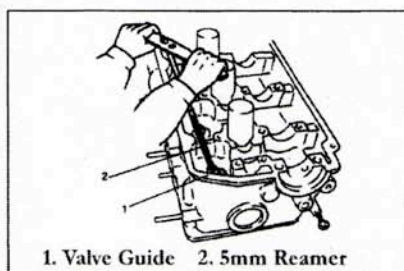

After guide installation, use a 5mm reamer to clean guide holes

Make sure no shavings are left in the holes

Cylinder Head (4-Valve)

Valve Spring

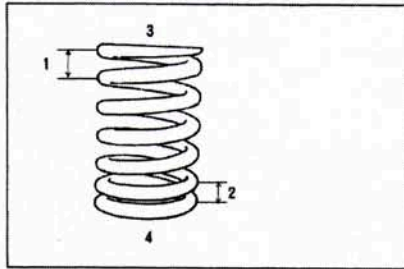

Assembly

1. Large Pitch Side
2. Small Pitch Side
3. Valve Spring Retainer Side
4. Valve Spring Seat Side

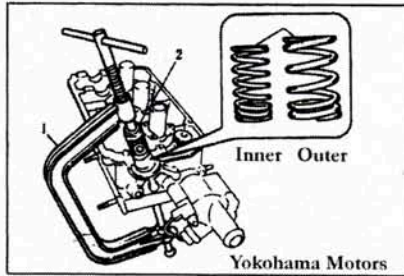

Assemble Springs and valves using a spring compressor as shown

Cylinder Head (4-Valve)

Assembly

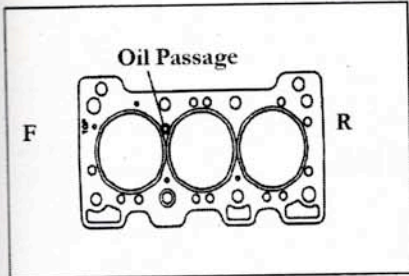

Install head gasket using the diagram on the left.

Make sure the gasket is oil free and clean

Do not use sealant on the head gasket

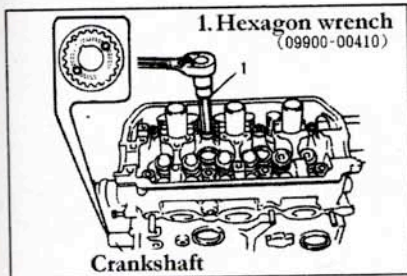

Cylinder Head Torque 600-650(kg.cm)

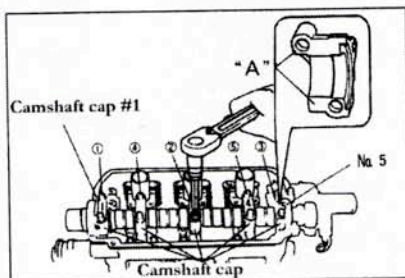
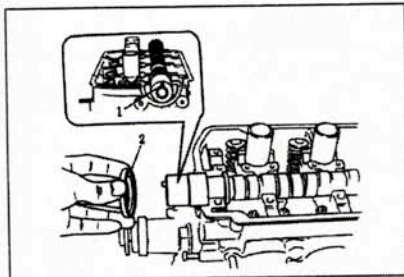
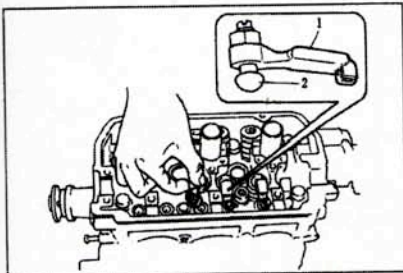

Camshaft Torque Spec

(kg.cm) 90-120

Cylinder Head (4-Valve)

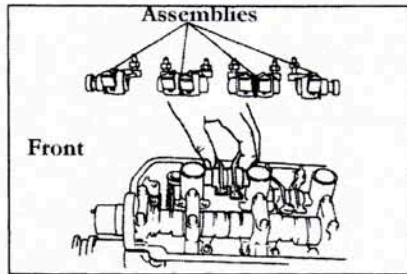

Assembly

Assemble Rocker Arms

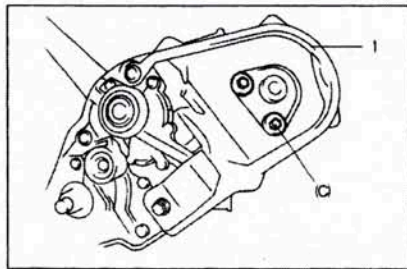

1. Timing Belt Inside Cover

Timing Belt Inside Cover (kg.cm) 90-120
Do not over torque

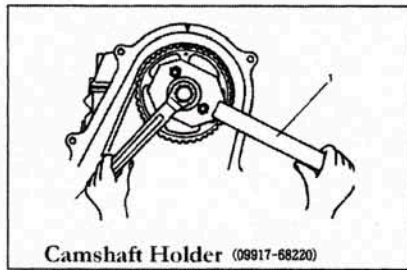

Set Camshaft pulley torque (kg.cm) 500-600

Assemble accessories and attachments

Set Valve Lash To Spec (see previous)

Camshaft Holder (09917-68220)

Piston & Rings-Connecting Rod-Cylinder

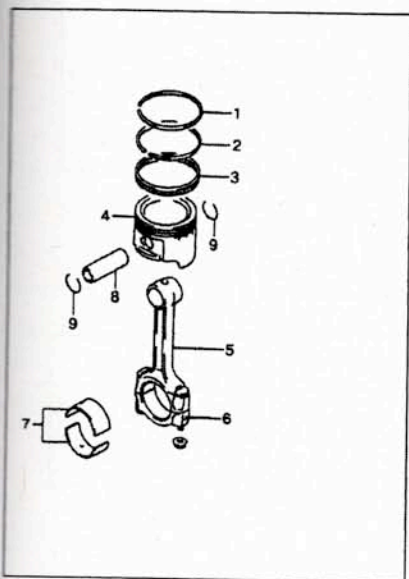

Piston Diagram 660cc 2 Valve and 4 Valve

1. Top Ring
2. 2nd Ring
3. Oil Ring
4. Piston Ring
5. Connecting Rod
6. Bearing Cap
7. Bearings
8. Piston Pin
9. C-Clip

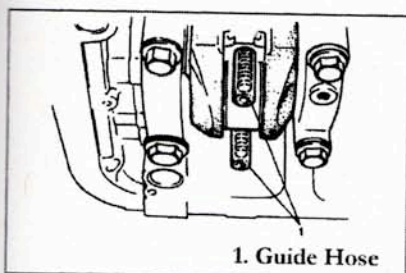

Note-When removing pistons place vacume hose or fuel hose over the bolt ends to prevent cylinder wall scratches during removal

Cylinder Diagram
Top

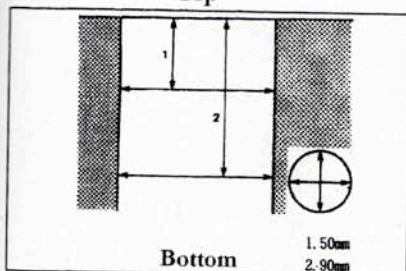

After piston removal check for a lip to determine excessive wearing. Excessive wearing will require cylinder boring. Oversize pistons and rings are available in 0.25(mm) or maximum 0.50(mm) sizes.

Use the chart on the left to determine diameter limits. The following charts and diagrams provide the correct sizes per boring requirments

Piston & Rings-Connecting Rod-Cylinder

Cylinder Bore Measurements

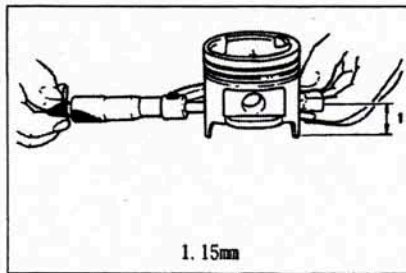
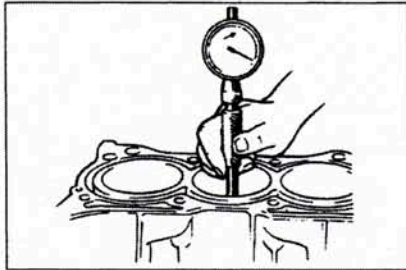

Cylinder Bore

Inside Diameter: 65.070(mm)

Taper Limit: 0.10(mm)

Note: If one or more cylinders are out of round or limits, all cylinders must be bored to the same size.

Piston Size

Piston Diameter (mm)	Allowance	64.965~64.985
	Oversize 0.25	65.215~65.235
	Oversize 0.50	65.465~65.485

Piston Rings

1. Piston Ring
2. Thickness Gage

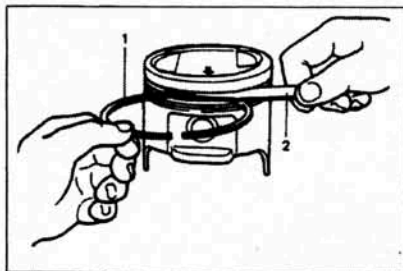

Ring Clearance Chart

Ring Side Clearance	Piston Ring	Allowance	Limit
	Top	0.03~0.07	0.12
	Second	0.02~0.06	0.10

Piston & Rings-Connecting Rod-Cylinder

Measure Ring End Gap

Before installing new piston rings, the ring end gap must be checked.

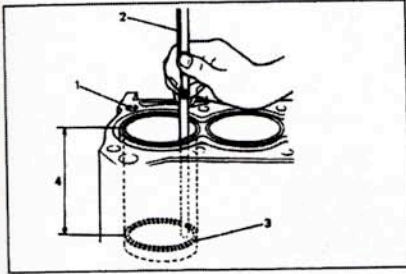

1. Cylinder Block
2. Feeler Gage
3. Piston Ring

Note: Check from top to bottom of cylinder

		Allowance	Limit
	Top Ring	0.12~0.27	0.7
	2nd Ring	0.15~0.30	0.7
	Oil Ring	0.20~0.70	1.8

Piston Pin

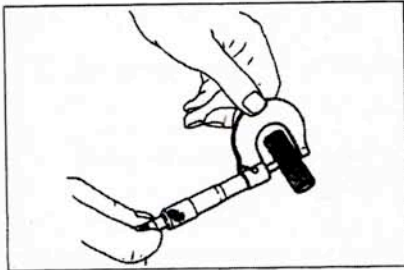

Piston Pin and Piston Boss Clearance

Piston Pin Hole		
	Allowance	
Outer	17.995~18.000 (15.995~16.000)	-
Piston Boss Inner Dia	18.006~18.014 (16.006~16.014)	-

() = 4 Valve

Connecting Rod Side Clearance

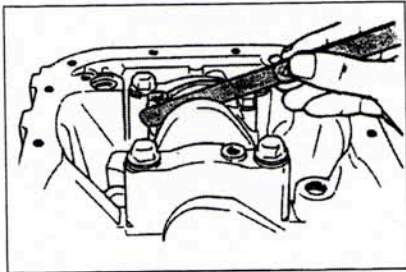

Connecting Rod Clearance

Allowance: 0.1-0.2(mm)

Piston & Rings-Connecting Rod-Cylinder

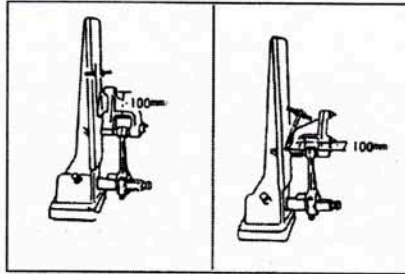

Alignment Machine

Connecting Rod Alignment

If a rod knocking noise was detected before disassembly, this test should be performed

Bend Rate Failure @ 0.05(mm)

Twist Rate Failure @ 0.10(mm)

Connecting Rod Bearings

*Note: Do Not Remove Old Bearings With Sharp Tools
Damage Will Occure*

Note: Always replace both upper and lower bearing as a set

Note: If an irregularity is indicated, measure the crank journal with a micrometer

Note: Only standard (STD) replacement bearings available

Warning: Do not rotate the crankshaft while gaging material is between the bearing and journal

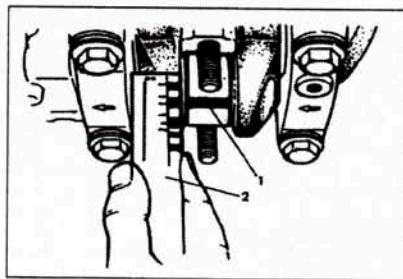

1. Plastigage 2. Scale

Bearing Clearance Measurement

Clearance
Allowance 0.020-0.040(mm)

Bearing Size
Normal: STD
Crankshaft (mm) 35.982-36.00

Bearing Cap Torque (kg.cm) 310-350

Piston & Rings-Connecting Rod-Cylinder

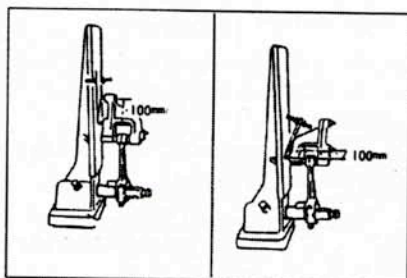

Alignment Machine

Connecting Rod Alignment

If a rod knocking noise was detected before disassembly, this test should be performed

Bend Rate Failure @ 0.05(mm)

Twist Rate Failure @0.10(mm)

Connecting Rod Bearings

*Note: Do Not Remove Old Bearings With Sharp Tools
Damage Will Occure*

*Note: Always replace both upper and lower bearing as
a set*

*Note: If an irregularity is indicated, measure the crank
journal with a micrometer*

Note: Only standard (STD) replacement bearings available

*Warning: Do not rotate the crankshaft while
gaging material is between the
bearing and journal*

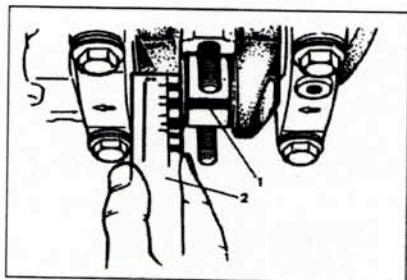

1. Plastigage 2. Scale

Bearing Clearance Measurement

Clearance
Allowance 0.020-0.040(mm)

Bearing Size
Normal: STD
Crankshaft (mm) 35.982-36.00

Bearing Cap Torque (kg.cm) 310-350

Piston & Rings-Connecting Rod-Cylinder

Piston Assembly

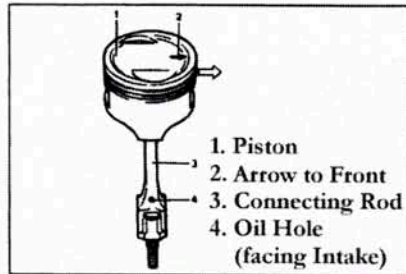

Note: Always use new piston rings

Install the connecting rod to the piston, making sure the piston direction arrow on the piston facing the front of the engine.

Make sure the piston pin is well lubricated, install retaining clips and verify they are well seated.

Piston Ring Chart

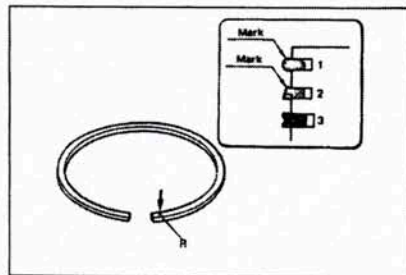

1. Top Compression Ring
2. Secondary Compression Ring
3. Oil Ring

Ring Gap Location

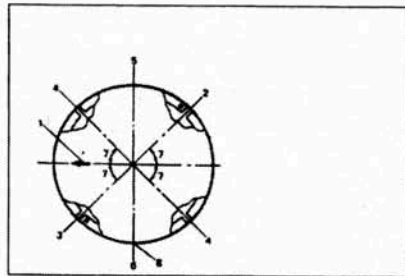

Use the chart to the left for Ring Gap Direction

1. Arrow (Pointing to front of engine)
2. Top Compression Ring
3. Second Compression Ring
4. Oil Ring
5. Intake direction
6. Exhaust direction
7. 45 degrees
8. Oil Ring

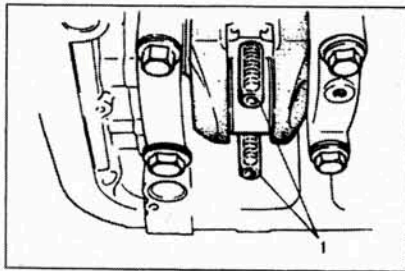

1. Guide Hose to protect journal

Main Bearing-Crankshaft, Cylinder Block

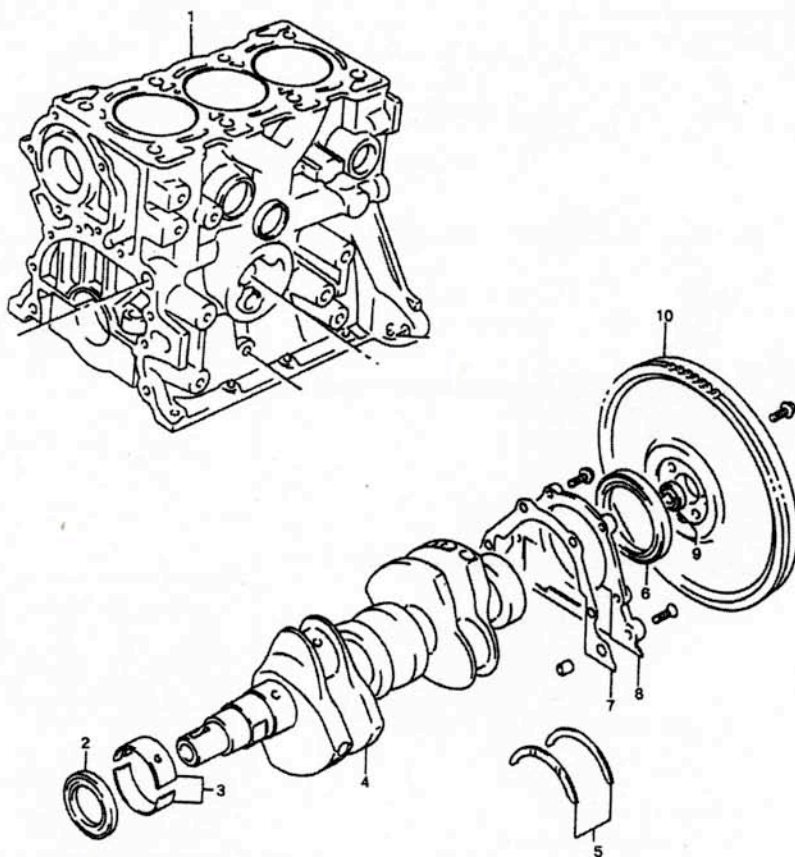

- 1. Cylinder Block
- 2. Front Main Seal
- 3. Main Bearing
- 4. Crankshaft

- 5. Thrust Bearing
- 6. rear Oil Seal
- 7. Oil Seal Housing Gasket
- 8. Oil Seal Housing

- 9. Input Shaft Bearing
- 10. Flywheel

Yokohama Motors

Main Bearing-Crankshaft, Cylinder Block

Crankshaft Inspection

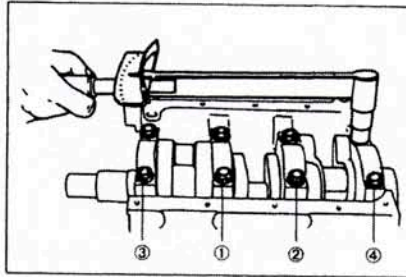

***Note:** Before removing crankshaft verify previous torque setting were correct

Follow the torque sequence guild to the left.
Torque should be (kg.cm) 550-600

Remove Crankshaft

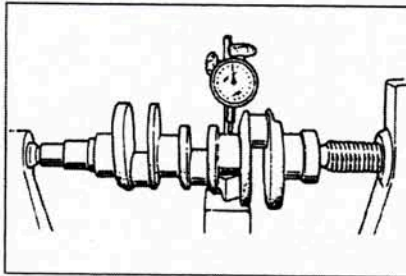

Crankshaft Journal Taper/Out of round Limit
Using a dial gage check the crankshaft. The test should involve minimum 3 turns per Journal

Out of round Limit: 0.03(mm)

Thrust Bearing

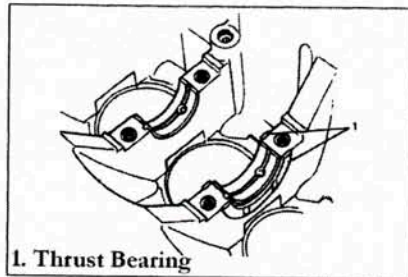

Inspect thrust bearings for unusual ware.

Remove thrust bearings and discard

***Not:** Do not re-use thrust bearings

Replace with new bearings

Main Bearing-Crankshaft, Cylinder Block

Crankshaft Inspection

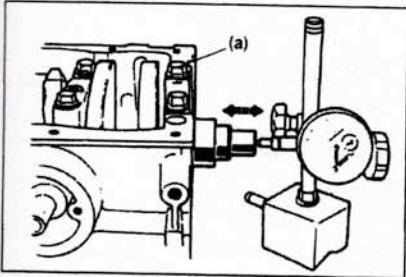

Main Bearing torque (kg.cm) 550-600

Crankshaft End-Play

Allowance: 0.13-0.28(mm)

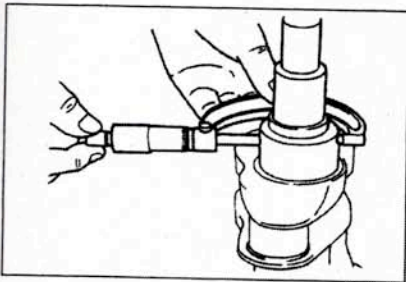

Using a micrometer, check journal taper

Crankshaft Journal STD

43.982-44.000(mm)

Journal Taper Allowance: 0.01(mm)

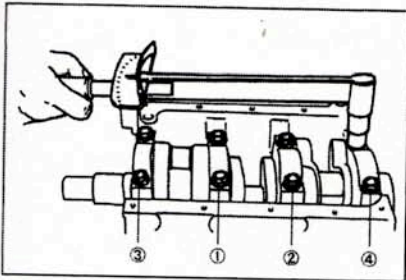

Re-Install Crankshaft and torque to Spec

Torque (kg.cm) 550-600

Use the diagram on the left for sequence

Crankshaft Bearing Oil Hole

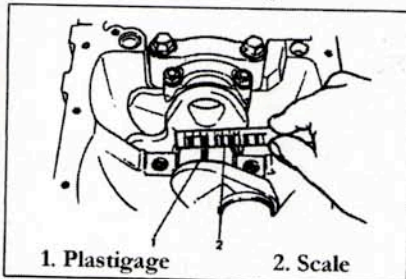

Crankshaft Bearing Orifice
(Oil Hole)

Allowance: 0.020-0.040(mm)

Main Bearing-Crankshaft, Cylinder Block

1. Rear Oil Seal

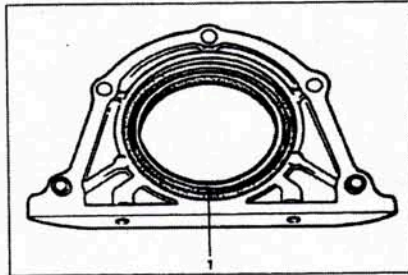

Install new rear oil seal

*Note: Take caution not to damage seal Lip

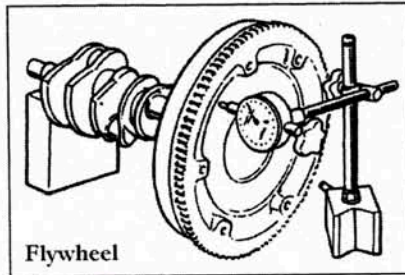

Flywheel

Flywheel Roundness Check

Limit (mm) 0.2

Flywheel Torque: (kg.cm) 400-450

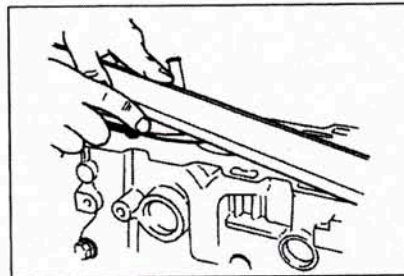

Cylinder Block Deck Check

Using a straight edge bar and a feeler gage check head deck for levelness

Allowance: 0.05(mm)

Out of spec, have deck re-surfaced

Engine Related Diagrams & Part Numbers

Engine Gasket Set (4V)

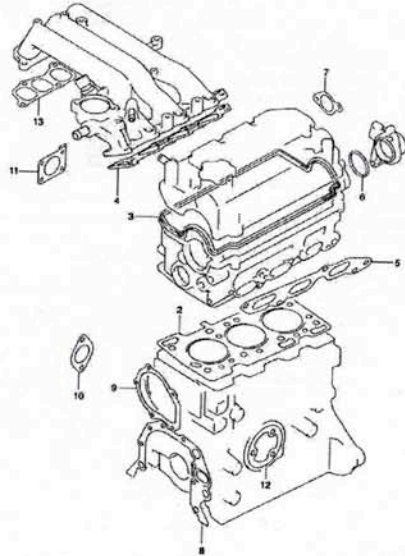

- | | |
|----------------------|---------------------------------------|
| 1. #11402-78881 | Gasket Set: Engine |
| 2. #11141-81401 | Gasket: Cylinder Head |
| 3. #11189-81402 | Gasket Cylinder Head Cover |
| 4. #13119-71G00 | Gasket Intake Manifold |
| 5. #14114-63F00 | Gasket: Exhaust Manifold |
| 6. #11162-81400 | O Ring |
| 7. #17699-53F01 | Gasket |
| 8. #16119-76G00 | Gasket: Oil Pump |
| 9. #17431-73001 | Gasket: Water Pump |
| 10. #17559-73000-H17 | Gasket: Water Inlet |
| 11. #13421-77G00 | Gasket: Throttle Body |
| 12. #16539-76001 | Gasket: Oil Filter Adapter Case (4WD) |
| 13. 13139-60H30 | Gasket |

Engine Gasket Set (4V)

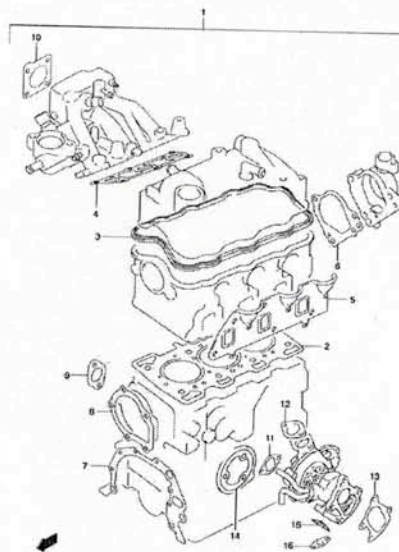

Turbo-4V

- | | | |
|------|-----------------|--|
| 1-1 | 11401-78894 | Gasket Set, Engine |
| 1-2 | 11401-60810 | Gasket Set, Engine: DA52V-DB52V-DA52W |
| 2 | 11141-81401 | Gasket: Cylinder Head |
| 3 | 11189-70D50 | Gasket: Valve Cover |
| 4 | 13119-84360 | Gasket: Intake Manifold |
| 5 | 14141-67F02 | Gasket: exhaust Manifold |
| 6-1 | 11169-70D00 | Gasket: Case |
| 6-2 | 11169-76G00 | Gasket: Case DA52T-DB52T-DA52V-DB52V-DA52W |
| 7 | 16119-76G00 | Gasket: Oil Pump Case |
| 8 | 17431-73001 | Gasket: Water Pump |
| 9 | 17559-73000-H17 | Gasket: Water Inlet |
| 10 | 13421-77G00 | Gasket: Throttle Body |
| 11 | 13955-56F00 | Gasket: Intake Air Pipe |
| 12 | 13965-56F00 | Gasket: Outlet Air Pipe |
| 13-1 | 14182-72B51 | Gasket: Turbo Outlet Pipe |
| 13-2 | 14182-60H50 | Gasket: Turbo Outlet Pipe DA52V-DB52V-DA52W |
| 14 | 16539-76001 | Gasket: Oil Filter Adapter Case |
| 15 | 14181-81051 | Gasket: Exhaust No.1 |
| 16 | 13945-70G50 | Gasket: Oil Drain |

Cylinder Head (4V)

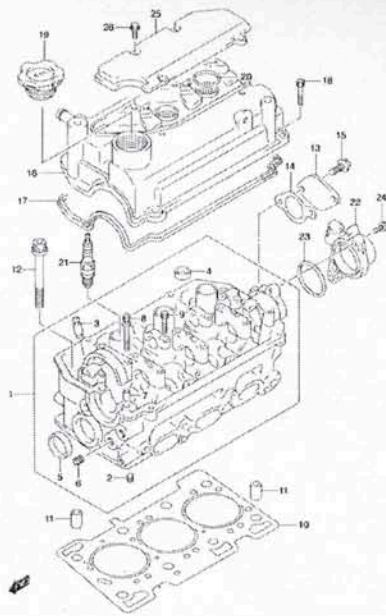

DASZT.2.003
CYLINDER HEAD (4V)

- | | | |
|-------|-----------------|-------------------------------|
| 1. | 11100-77G00 | Cylinder Head Assembly |
| 2. | 11112-53A00 | Plug: Oil Venturi |
| 3. | 11115-77G00-001 | Valve Guide |
| 4. | 09241-20006 | Plug, Outside Diameter:20 |
| 5. | 09241-30009 | Plug, OD:30 |
| 6. | 09246-05006 | Plug, 1/8PT, Hi:5.5 |
| 7. | 09206-08001 | Pin, 6.2x8x11 |
| 8. | 07130-06403 | Bolt |
| 9. | 09103-06185 | Bolt, 6x20 |
| 10. | 11141-81401 | Gasket: Cylinder Head |
| 11. | 04211-13189 | Pin |
| 12. | 1117-52E10 | Bolt: Cylinder Head |
| 13. | 11116-79A00 | Plate: Cylinder Head |
| 14. | 17699-53F01 | Gasket |
| 15. | 01550-08203 | Bolt |
| 16. | 11170-79A01 | Cover: Cylinder Head |
| 17. | 11189-81402 | Gasket: Cylinder Head Cover |
| 18. | 01550-06253 | Bolt |
| 19. | 16920-86502 | Cap: Oil Filler |
| 20. | 11179-81402 | O Ring |
| 21-1. | #09482-00448 | Spark Plug: DCPR7E (NGK) |
| 21-2. | #09482-00449 | Spark Plug: XU22EPR-U (Denso) |
| 22. | 33221-76G00 | Case: Cam Position Sensor |
| 23. | 11162-81400 | O Ring |
| 24. | 01550-06203 | Bolt |
| 25. | 11180-77G00 | Cover: Cylinder Head Upper |
| 26. | 01547-06163 | Bolt |

Cylinder Head (Turbo)

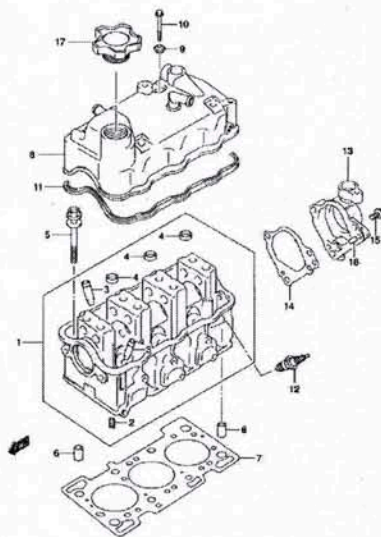

CYLINDER HEAD (TURBO)

- | | | |
|-------|------------------|---------------------------------|
| 1. | 11110-7002 | Cylinder Head |
| 2. | 11112-73002 | Plug: Oil Venturi |
| 3. | 11115-62D00-001 | Valve Guide |
| 4. | 09241-20006 | Plug: OD:20 |
| 5. | 09116-101116 | Bolt 10x87 |
| 6. | 04211-13189 | Pin |
| 7. | 11141-81401 | Gasket: Cylinder Head |
| 8. | 11170-60H50 | Cover: Cylinder Head |
| 9. | 11180-60B00 | Seal/Washer Cylinder Head Cover |
| 10. | 09113-06002 | Bolt 6x65 |
| 11. | 11189-70D50 | Cover Gasket |
| 12-1. | BPR5E (NGK) | Spark Plug |
| 12-2. | W16EPR-U (Denso) | Spark Plug |
| 13. | 11161-78A50 | Case: Cam Position Sensor |
| 14. | 11169-76G00 | Gasket |
| 15. | 09103-08152 | Bolt 8x25 |
| 16. | 04221-06129 | Pin |
| 17. | 16920-86502 | Cap: Oil Filter |

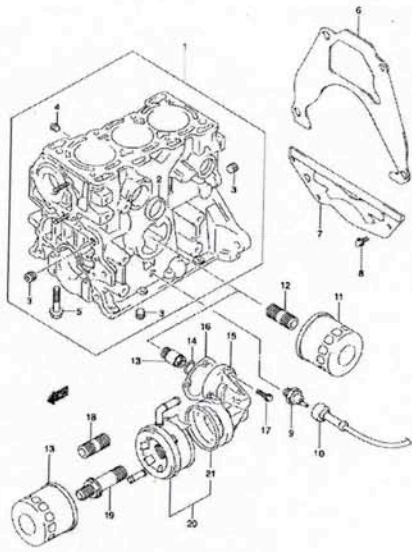

Cylinder Block

- 1-1. 11200-53F10 Block Assembly (4V)
- 1-2. 11200-55F00 Block Assembly (Turbo)
- 2. 09241-300009 Plug, OD:30
- 3. 09246-60002 Plug, 1/4PT, H:7.5
- 4. 09246-05006 Plug, 1/8PT, H:5.5
- 5. 09103-10022 Bolt 10x54
- 6-1. 11310-78A00 Plate: Clutch Housing Upper (MT)
- 6-2. 11311-78A20 Plate: Clutch Housing Upper (AT)
- 7-1. 11320-78A02 Plate: Clutch Housing Lower (MT)
- 7-2. 11320-78A21 Plate: Clutch Housing Lower (AT)
- 8-1. 01550-06103 Bolt (MT)
- 8-2. 01550-06103 Bolt (AT)
- 9. 37820-82001 Oil Pressure Switch
- 10. 36895-78A01 Oil Pressure Wire
- 11-1. 16510-82703 Oil Filter (Tokyo ROKI)
- 11-2. 16510-81403 Oil Filter (Denso)
- 12. 11241-7300 Adapter Pipe
- 13. 11241-85400 Oil Filter (4V-4WD-Turbo)
- 14. 09280-16005 O Ring
- 15. 16530-78A00 Case: Oil Cooler Adapter
- 16. 16539-76001 Gasket
- 17. 01550-06253 Bolt
- 18. 11241-73003 Adapter Adachment Pipe
- 19. 11241-82C00 Oil Cooler Adapter Pipe
- 20. 16600-78A00 Oil Cooler Assembly
- 21. 16221-78A00 Gasket

Cylinder Block

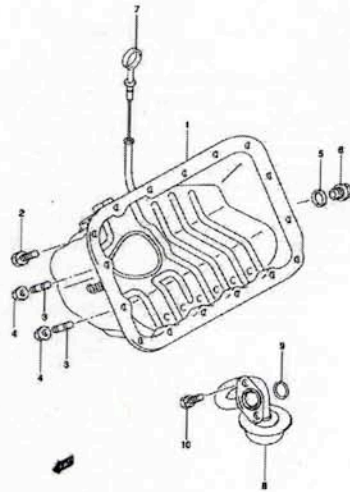

Oil Pan

- 1. 11510-78A10 Oil Pan
- 2. 09117-06033 Bolt 6x12
- 3. 01411-06123 Stud
- 4. 08316-10063 Nut
- 5. 09247-14027 Plug
- 6. 09168-14015 Gasket
- 7. 16910-78A01 Oil Level Stick (Dip Stick)
- 8. 16520-78A00 Strainer
- 9. 09280-16005 O Ring
- 10. 01570-06163 Bolt

Oil Pan

Crankshaft (4V)

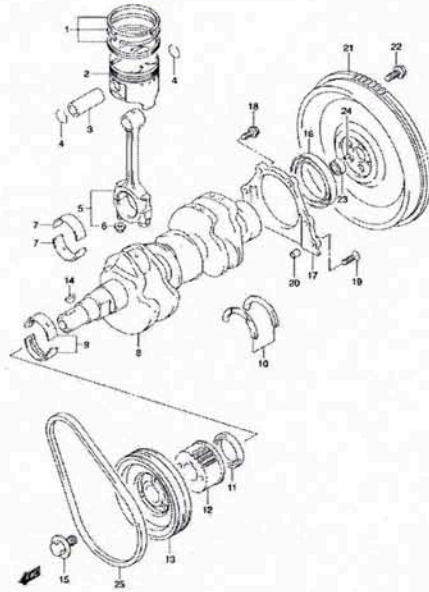

Crankshaft (4V)

- | | | |
|-------|-----------------|--------------------------------|
| 1-1. | 12140-51F10 | Ring Set: Piston STD |
| 1-2. | 12140-51F10-025 | Ring Set: Piston OS: 0.25 |
| 1-3. | 12140-51F10-050 | Ring Set: Piston OS: 0.50 |
| 2-1. | 12111-71G00-0B0 | Piston: STD |
| 2-2. | 12111-71G00-025 | Piston: OS: 0.25 |
| 2-3. | 12111-71G00-050 | Piston: OS: 0.50 |
| 3. | 12151-78110 | Piston Pin |
| 4. | 09381-16001 | Snap Ring |
| 5. | 12160-60D02 | Connecting Rod Assembly |
| 6. | 09159-08033 | Nut |
| 7-1. | 12181-81401-0A0 | Con Rod Bearing STD |
| 7-2. | 12181-81401-025 | Con Rod Bearing US: 0.25 |
| 8. | 12221-50E00 | Crankshaft |
| 9-1. | 12300-61810-0A0 | Crankshaft Bearing Set STD |
| 9-2. | 12300-61810-025 | Crankshaft Bearing Set US:0.25 |
| 10-1. | 12300-82820 | Thrust Bearing: T:2.5 |
| 10-2. | 12300-82820-012 | Thrust Bearing: T:2.563 |
| 11. | 09283-32042 | Oil Seal 32x47x6 |
| 12. | 12631-61D01 | Timing Belt Pulley |
| 13. | 12610-61H00 | Crankshaft Pulley |
| 14. | 08341-31059 | Key |
| 15. | 12619-60B00 | Crankshaft Pulley Bolt |

Crankshaft (4V) Part 2

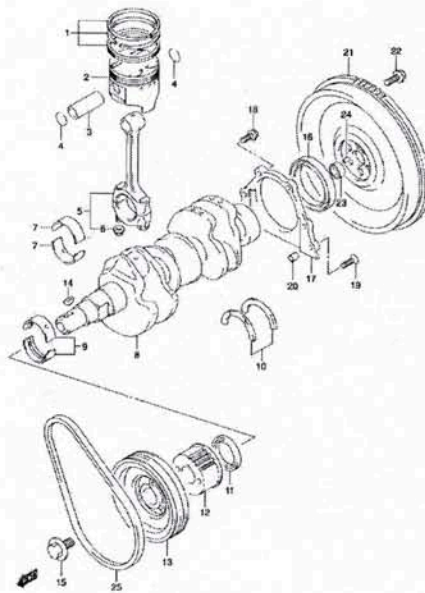

Crankshaft (4V)

- | | | |
|-------|-------------|-----------------------------------|
| 16. | 09283-60005 | Oil Seal, 60x80x8 |
| 17. | 11341-70B01 | Housing Oil Seal |
| 18. | 01550-06203 | Bolt |
| 19. | 02122-06253 | Screw |
| 20. | 04211-09109 | Pin |
| 21. | 12620-78A00 | Flywheel |
| 22. | 09103-10097 | Bolt 10x17 |
| 23. | 12623-70B00 | Bearing: Input Shaft |
| 24-1. | 04221-06129 | Pin (MT) |
| 24-2. | 09205-06009 | Spring Pin 6x14 (AT) |
| 25. | 17521-78A01 | Belt: Alternator L:758mm (LFM-30) |

Crankshaft (Turbo)

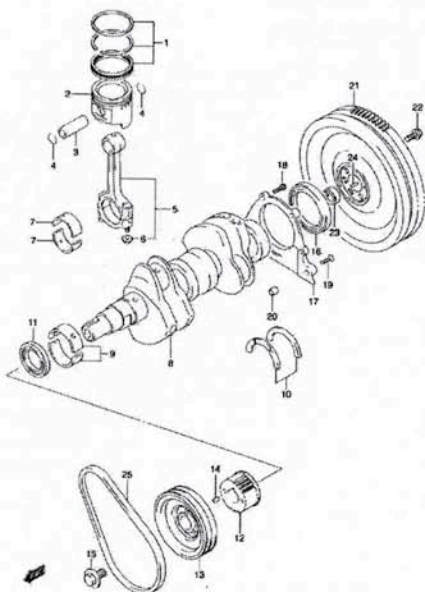

- 1-1. 12140-50E50 Ring Set: Piston STD
- 1-2. 12140-50E50-025 Ring Set: Piston OS 0.25
- 1-3. 12140-50E50-050 Ring Set: Piston OS 0.50
- 2-1. 12111-78A50-0B0 Piston: STD (Truck)
- 2-2. 12111-60D51-0B0 Piston: STD (Van)
- 2-3. 12111-78A50-025 Piston: OS 0.25 (T)
- 2-4. 12111-60D51-025 Piston: OS 0.25 (Van)
- 2-5. 12111-78A50-050 Piston: OS 0.50 (Truck)
- 2-6. 12111-60D51-050 Piston: OS 0.50 (Van)
- 3. 12151-54A50 Piston Pin (T&V)
- 4. 09381-18005 Snap Ring
- 5-1. 12160-76G50 Connecting Rod Assembly (T)
- 5-2. 12160-60d51 Connecting Rod Assembly (V)
- 6. 09159-08033 Nut
- 7-1. 12181-81401-0A0 Con Rod Bearing (T)
- 7-2. 12181-81051-0A0 Con Rod Bearing (V)
- 7-3. 12181-81401-025 Bearing: UnderSize: 0.25 (T)
- 7-4. 12181-81051-025 Bearing: US 0.25 (Van)
- 8-1. 12221-50E00 Crankshaft (T)
- 8-2. 12221-60H50 Crankshaft (V)
- 9-1. 12300-61810-0A0 Bearing Set Crankshaft STD (T & V)
- 9-2. 12300-61810-025 Bearing US: 0.25 (T&V)
- 10-1. 12300-82820 Thrust Bearing T:2.5
- 10-2. 12300-82820-012 Thrust Bearing T:2.563
- 11. 09283-32042 Oil Seal 32x47x6

Crankshaft (Turbo)

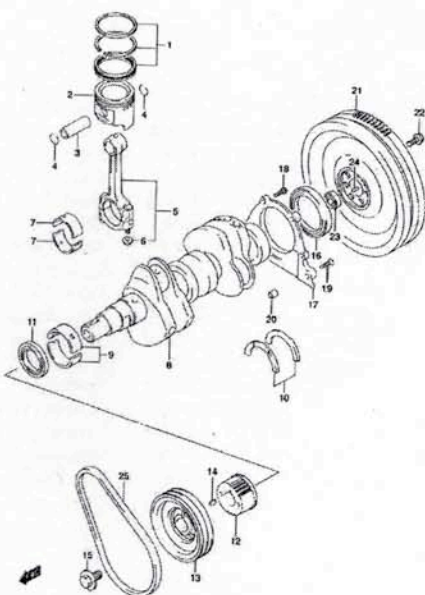

- 12. 12631-61D01 Timing Belt Pulley
- 13. 12610-61H00 Crankshaft Pulley
- 14. 08341-31059 Key
- 15. 12619-60B00 Crankshaft Pulley Bolt
- 16. 09283-60005 Oil Seal 60x80x8
- 17. 11341-70B01 Oil Seal
- 18. 01550-06203 Bolt
- 19. 02122-06253 Screw
- 20. 04211-09109 Pin
- 21. 12620-78A00 Flywheel
- 22. 09103-10097 Bolt 10x17
- 23. 12623-70B00 Bearing: Input Shaft
- 24-1. 04221-06129 Pin (MT)
- 24-2. 09205-06009 Spring Pin 6x14 (AT)
- 25. 17521-78A01 Alternator Belt: L:758mm (LFM-30)

Crankshaft (Turbo)

Camshaft-Valves (4V)

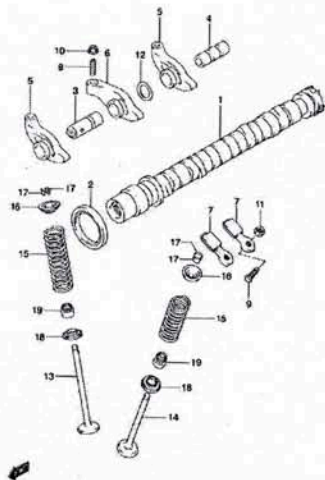

- | | | |
|-----|-------------|--------------------------|
| 1. | 12710-7900 | Camshaft |
| 2. | 09283-35047 | Oil Seal 35x47x6 |
| 3. | 12861-71G00 | Shaft: Rocket Arm No. 1 |
| 4. | 12862-71G00 | Shaft: Rocket Arm No.2 |
| 5. | 12841-77G11 | Rocker Arm: Intake No.1 |
| 6. | 12844-77G11 | Rocker Arm: Intake No.2 |
| 7. | 12845-77G00 | Rocker Arm: Exhaust |
| 8. | 12842-77G00 | Adjustment Screw: Intake |
| 9. | 12846-61D00 | Adjustment Screw |
| 10. | 12843-32400 | Nut |
| 11. | 12843-66D00 | Nut |
| 12. | 12891-81410 | Washer |
| 13. | 12911-77G00 | Valve: Intake |
| 14. | 12915-77G00 | Valve: Exhasut |
| 15. | 12921-51E00 | Spring: Valve |
| 16. | 12931-77G00 | Retainer |
| 17. | 12932-24400 | Keeper (Valve) |
| 18. | 12933-51E00 | Seat: Valve Spring |
| 19. | 09289-05012 | Seal: Valve Stem |

Camshaft-Valves (4V)

Camshaft-Valves (Turbo)

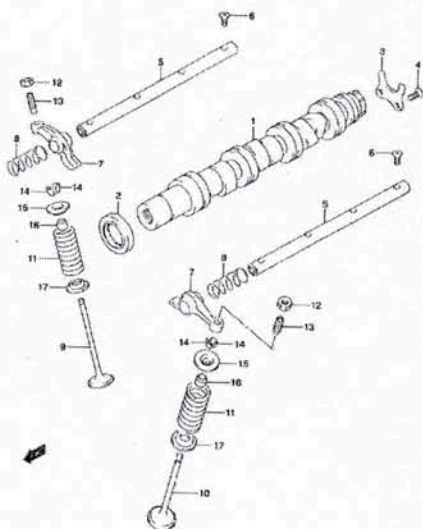

- | | | |
|-----|--------------|------------------------|
| 1. | 12710-60H50 | Camshaft |
| 2. | 09283-32042 | Oil Seal 32x47x6 |
| 3. | 12749-73002 | Plate: Camshaft Thrust |
| 4. | 02122-06123 | Screw |
| 5. | 12860-78102 | Shaft: Valve Rocker |
| 6. | 02122-06163 | Screw |
| 7. | 12841-77300 | Arm: Valve Rocker |
| 8. | 12891-51G00 | Spring: Rocker Arm |
| 9. | 12911-70B30 | Valve: Intake |
| 10. | 12915-70B00 | Valve: Exhaust |
| 11. | 12921-60H100 | Spring: Valve |
| 12. | 09159-07002 | Nut |
| 13. | 12848-73010 | Screw |
| 14. | 12932-24400 | Keeper (Valve) |
| 15. | 12931-60B01 | Retainer |
| 16. | 09289-05012 | Valve Stem Seal |
| 17. | 12933-86510 | Seat: Valve Spring |

Camshaft-Valves (Turbo)

Timing Belt (4V)

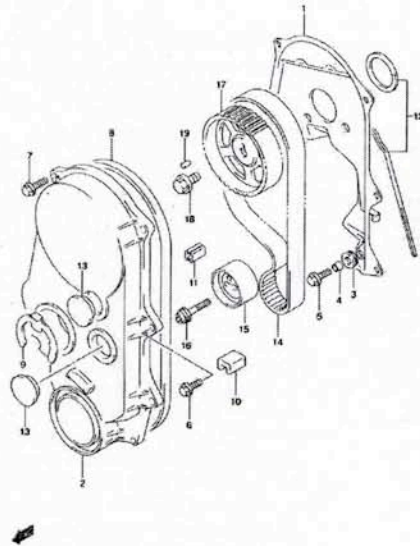

- | | |
|-----------------|---------------------------------|
| 1. 11360-79A00 | Cover: Timing Belt Inside |
| 2. 11390-77G01 | Cover: Outside |
| 3. 09308-10004 | Grommet |
| 4. 09180-06106 | Spacer 6.8x10x7 |
| 5. 09116-06167 | Bolt 6x20 |
| 6. 01550-06163 | Bolt |
| 7. 01550-06203 | Bolt |
| 8. 11396-77G00 | Seal: Timing Belt Cover-Outside |
| 9. 11397-76G00 | E-Ring: Timing Belt Cover |
| 10. 11394-77G00 | Seal |
| 11. 11394-70B00 | Seal |
| 12. 11480-77G00 | Seal Set: Timing Cover-Inside |
| 13. 09250-30017 | Cap: OD:36 |
| 14. 12761-79A00 | Belt: Timing |
| 15. 12810-76G00 | Tensioner |
| 16. 12815-76G00 | Bolt: Tensioner |
| 17. 12741-61D01 | Pulley: Camshaft Timing |
| 18. 01550-12253 | Bolt |
| 19. 09206-05001 | Pin |

Timing Belt (4V)

Timing Belt (Turbo)

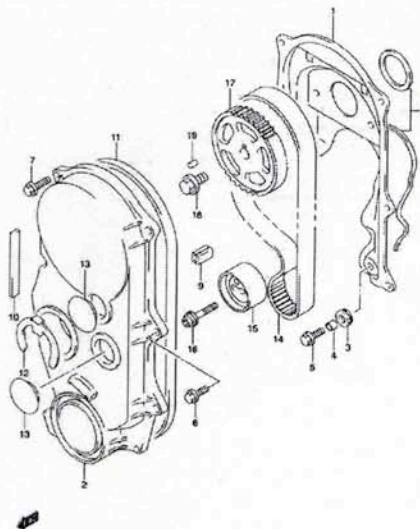

- | | |
|-----------------|------------------------------|
| 1. 11360-78A00 | Cover: Timing Belt-Inside |
| 2. 11390-76G01 | Cover: Outside |
| 3. 09308-10004 | Grommet |
| 4. 09180-06106 | Spacer: 6.8x8x10x7 |
| 5. 09116-06167 | Bolt 6x20 |
| 6. 01550-06163 | Bolt |
| 7. 01550-06203 | Bolt |
| 8. 11480-76G00 | Seal Set:Timing Cover-Inside |
| 9. 11394-70B00 | Seal |
| 10. 11395-76G00 | Seal |
| 11. 11396-76G00 | Seal |
| 12. 11397-76G00 | E Ring: Timing Cover |
| 13. 09250-30017 | Cap: OD:36 |
| 14. 12761-78A00 | Belt: Timing |
| 15. 12810-76G00 | Tensioner |
| 16. 12815-76G00 | Tensioner Bolt |
| 17. 12741-70D00 | Pulley: Camshaft Timing |
| 18. 01550-12253 | Bolt |
| 19. 09206-05001 | Pin |

Timing Belt (Turbo)

Intake Manifold/Throttle Body (4V)

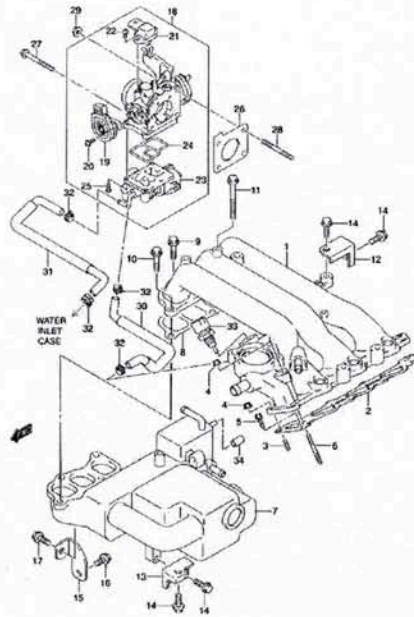

- | | | |
|-----|-------------|-------------------------------|
| 1. | 13110-60H30 | Intake Manifold |
| 2. | 13119-71G00 | Gasket: Intake Manifold |
| 3. | 01411-06203 | Stud Bolt |
| 4. | 08316-10063 | Nut |
| 5. | 01550-06203 | Bolt |
| 6. | 01411-06603 | Stud Bolt |
| 7. | 13130-60H30 | Surge Tank |
| 8. | 13139-60H30 | Gasket: Surge Tank |
| 9. | 01550-08253 | Bolt |
| 10. | 01550-08303 | Bolt |
| 11. | 01550-08803 | Bolt |
| 12. | 13161-60H30 | Bracket: Intake Manifold No.1 |
| 13. | 13162-60H30 | Bracket: Intake Manifold No.2 |
| 14. | 01550-08203 | Bolt |
| 15. | 13163-60H30 | Bracket: Surge Tank |
| 16. | 01550-08163 | Bolt |
| 17. | 01550-08203 | Bolt |
| 18. | 13400-60H30 | Throttle Body Assembly |
| 19. | 13420-77G00 | Throttle Body Position Sensor |
| 20. | 13428-77G10 | Screw |
| 21. | 18590-72F21 | Pressure Sensor |
| 22. | 13601-05148 | Screw 5x14 |
| 23. | 18117-60H30 | Valve: Idle Throttle Control |
| 24. | 14139-77G10 | Gasket: Valve |
| 25. | 13601-05148 | Screw 5x14 |

Intake Manifold/Throttle Body (4V)

Intake Manifold/Throttle Body (4V) Part 2

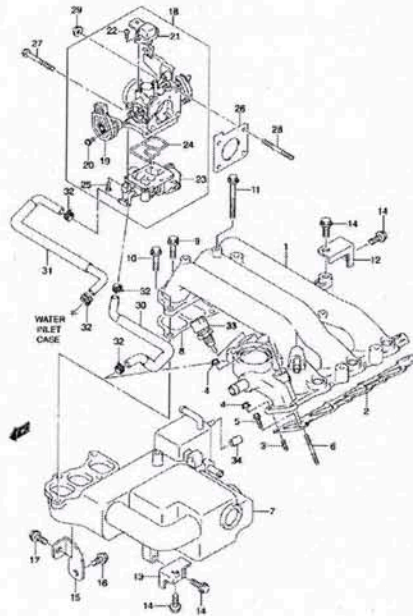

- | | | |
|-----|-------------|-----------------------|
| 26. | 13421-77G00 | Gasket: Throttle Body |
| 27. | 01550-06503 | Bolt |
| 28. | 01421-06453 | Stud Bolt |
| 29. | 08316-10063 | Nut |
| 30. | 13491-60H30 | Hose: Water-TB Inlet |
| 31. | 13492-60H30 | Hose: Water-TB Outlet |
| 32. | 09401-12410 | Clip |
| 33. | 13650-50F10 | Water Pressure Sensor |
| 34. | 09250-04003 | Plug: OD:8 |

Intake Manifold/Throttle Body (4V) Part 2

Intake Manifold/Throttle Body (Turbo)

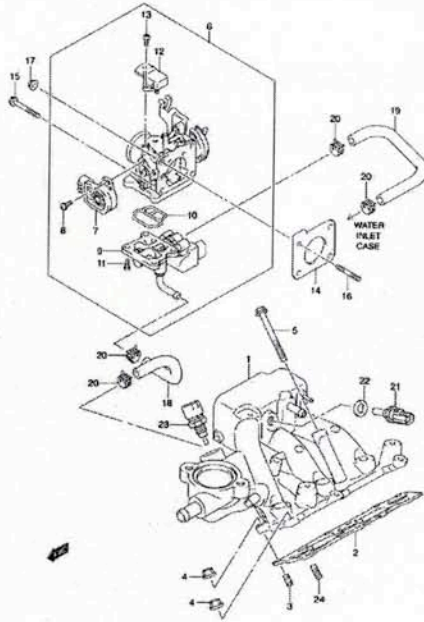

- | | | |
|-----|-------------|--------------------------|
| 1. | 13110-60H50 | Intake Manifold |
| 2. | 13119-84360 | Gasket: Intake Manifold |
| 3. | 01411-08203 | Stud Bolt |
| 4. | 08316-10083 | Nut |
| 5. | 01550-08953 | Bolt |
| 6. | 13400-78A50 | Throttle Body Assembly |
| 7. | 13420-77G00 | Throttle Position Sensor |
| 8. | 13428-77G10 | Screw |
| 9. | 18117-78A50 | Valve: Idle Control |
| 10. | 14139-70G30 | Gasket |
| 11. | 13601-05148 | Screw 5x14 |
| 12. | 18590-76G50 | Pressure Sensor |
| 13. | 13428-77G10 | Screw |
| 14. | 13421-77G00 | Throttle Body Gasket |
| 15. | 01550-06503 | Bolt |
| 16. | 01421-06453 | Stud Bolt |
| 17. | 08316-10063 | Nut |
| 18. | 13491-78A50 | Hose: Water Inlet |
| 19. | 13492-78A50 | Hose: Water Outlet |
| 20. | 09401-12410 | Clip |
| 21. | 13650-61B00 | Temp Sensor |
| 22. | 09168-12016 | Gasket: 12.2x21x0.8 |
| 23. | 13650-50F10 | Water Temp Sensor |
| 24. | 01411-08253 | Stud Bolt |

Intake Manifold/Throttle Body (Turbo)

Water Pump (All)

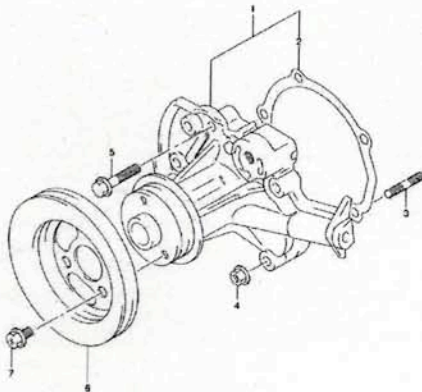

- | | | |
|----|-------------|---------------------------|
| 1. | 17400-78880 | Water Pump Set (Assembly) |
| 2. | 17431-73001 | Gasket: Water Pump |
| 3. | 01411-06253 | Stud Bolt |
| 4. | 08316-10063 | Nut |
| 5. | 01550-06303 | Bolt |
| 6. | 17511-76G10 | Water Pump Pulley |
| 7. | 02162-06103 | Bolt |

Water Pump (All)

Turbocharger (Turbo)

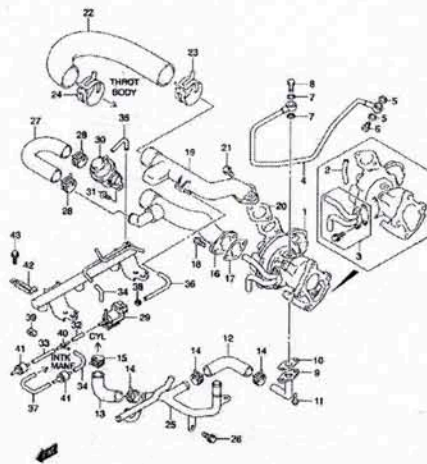

- 22. 13962-78A70 Hose: Turbocharger Outlet
- 23. 09402-50511 Clamp
- 24. 09402-57511 Clamp
- 25. 13980-60H150 Pipe: Drain
- 26. 01550-06123 Bolt
- 27. 13924-78A50 Hose: Air Bypass Outlet
- 28. 09401-23405 Clip
- 29. 18117-60H80 Valve: 3-Way Solenoid
- 30. 18119-78A50 Valve: Air Bypass
- 31. 01550-06253 Bolt
- 32. 09355-35754-601 Hose: 3.5x7.5x601
- 33-1. 09355-35754-601 Hose: 3.5x7.5x601
- 34.-37. 09355-35754-601
- 38. 09401-06405 Clip
- 39. 09408-00035 Clip
- 40. 09367-04002 3-Way Joint
- 41. 95569-78040 Check Valve
- 42. 09404-08207 Clamp L:97
- 43. 01550-06123 Bolt

Turbocharger (Turbo)

Turbocharger (Turbo)

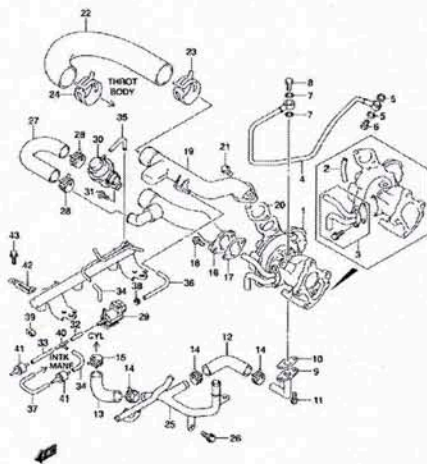

- 1-1. 13900-78A53 Turbocharger (Truck)
- 1-2. 13900-60H62 Turbocharger (Van)
- 2-1. 13913-78A50 Hose: Wastegate (T)
- 2-2. 13913-60H60 Hose: Wastegate (V)
- 3-1. 13919-78A50 Pipe Set: Water (T)
- 3-2. 13919-60H60 Pipe Set: Water (V)
- 4-1. 13930-78A51 Pipe: Turbo Oil Intake (T)
- 4-2. 13930-60H60 Pipe: Turbo Oil Intake (V)
- 5. 09161-10009 Washer 10x15x1.5
- 6-1. 09360-10049 Union Bolt (T)
- 6-2. 09360-10031 Union Bolt (V)
- 7. 09168-08016 Gasket: 8.2x14x1
- 8. 13948-76G50 Union Bolt
- 9. 13940-60H50 Oil Drain Joint
- 10. 13945-70G50 Gasket: Drain
- 11. 07120-06163 Bolt
- 12. 13946-60H50 Hose: Oil Drain No.1
- 13. 13947-78A50 Hose: Oil Drain No.2
- 14. 09401-18404 Clip
- 15. 09401-20404 Clip
- 16. 13950-78A50 Pipe: Turbo Inlet
- 17. 13955-56F00 Gasket
- 18. 01550-06253 Bolt
- 19. 13960-60H51 Pipe: Outlet
- 20. 13695-56F00 Gasket: Outlet
- 21. 01550-06853 Bolt

Turbocharger (Turbo)

Conversion Charts

CONVERSION OF TORQUE					
Convert			Convert		
From	To	Multiply	From	To	Multiply
lb.in.	oz.in.	16	oz.in.	lb.in.	.0625
lb.in.	lb.ft.	.08333	lb.ft.	lb.in.	12
lb.in.	kg.cm.	1.1519	kg.cm.	lb.in.	.8681
lb.in.	kg.m.	.011519	kg.m.	lb.in.	86.81
lb.in.	Nm	.133	Nm	lb.in.	8.85
lb.in.	dNm	1.13	dNm	lb.in.	.885
lb.ft.	kg.m.	.1382	kg.m.	lb.ft.	7.236
lb.ft.	Nm	1.356	Nm	lb.ft.	.7376
Nm	dNm	10	dNm	Nm	.10
Nm	kg.cm.	10.2	kg.cm.	Nm	.09807
Nm	kg.m.	.102	kg.m.	Nm	9.807

Thank you!

For More Information on other fine publications check the following resources.

www.lulu.com

www.amazon.com

Automotive Specialty

www.yokohamamtors.com

Automotive Service Manuals

Suzuki

Subaru

Honda

Mitsubishi

Daihatsu

Toyota

Nissan

Others

**The Complete F6A Engine Overhaul
&
Parts Manual**

**VIN Decoding
Engine Identification
Service Data
Intake Manifolds (Turbo-Fuel Injected-Carbureted)
Timing Belt
Valve Adjustments
Oil System & Pump Overhaul
Cylinder Head Overhaul
Pistons-Connecting Rods-Camshaft Specifications
Bearings & Crankshaft
Cylinder Block Specifications & Part Numbers
Engine Mounts & Frame Diagrams
Complete Engine Part Number Guide**

All this and more in the new Second Edition Version!

**Service & Parts Manual
Second Edition**

DE51V

DF51V

DC51T

DD51T

DC51B

DA52T

DB52T

DA52V