

## FOREWORD

This manual contains procedures for diagnosis, maintenance adjustments, service operations, replacement of components (Service) and for disassembly and assembly of major components.

The contents are classified into sections each of which is given a section number as indicated in the Table of Contents on next page. And on the first page of each individual section is an index of that section.

This manual should be kept in a handy place for ready reference of the service work. Strict observance of the so specified items will enable one to obtain the full performance of the vehicle.

When replacing parts or servicing by disassembling, it is recommended to use SUZUKI genuine parts, tools and service materials (lubricants, sealants, etc.) as specified in each description.

All information, illustrations and specifications contained in this literature are based on the latest product information available at the time of publication approval. The right is reserved to make changes at any time without notice. And used as the main subject of description is the vehicle of standard specifications among others. Therefore, note that illustrations and photos may differ from the vehicle being actually serviced.

### **IMPORTANT:**

It is important to note that, during any vehicle maintenance procedures, replacement fasteners must have the same measurements as those removed.

Mismatched or incorrect fasteners can result in vehicle damage or malfunction, or possible personal injury.

Therefore, fasteners removed from the vehicle should be saved for re-use whenever possible.

Where the fasteners are not satisfactory for reuse, care should be taken to select a replacement that matches the original.

Additional information concerning this subject will be found in the section 0 (METRIC INFORMATION).

This service manual is applicable to vehicles of and after the following body number.

Effective body No.:

JS3JC51C □ J4235001

JS3JC51V □ J4150001

JS4JC51C □ J4235001

JS4JC51V □ 54150001

*SUZUKI MOTOR CO LTD*

*TECHNICAL DEPARTMENT  
AUTOMOBILE SERVICE DIVISION*



# TABLE OF CONTENTS

	SECTION
<b>GENERAL, SPECIAL TOOLS AND SERVICE MATERIALS</b>	<b>0</b>
<b>PERIODIC MAINTENANCE SERVICE</b>	<b>1</b>
<b>TROUBLE SHOOTING</b>	<b>2</b>
<b>ENGINE</b>	<b>3</b>
<b>FUEL SYSTEM (CARBURETOR, AIR CLEANER FUEL PUMP AND FUEL FILTER)</b>	<b>4</b>
<b>EMISSION CONTROL SYSTEM</b>	<b>5</b>
<b>ENGINE COOLING SYSTEM</b>	<b>6</b>
<b>CAR HEATER</b>	<b>7</b>
<b>IGNITION SYSTEM</b>	<b>8</b>
<b>CRANKING SYSTEM</b>	<b>9</b>
<b>CHARGING SYSTEM</b>	<b>10</b>
<b>CLUTCH</b>	<b>11</b>
<b>GEAR SHIFTING CONTROL</b>	<b>12</b>
<b>TRANSMISSION</b>	<b>13</b>
<b>TRANSFER GEAR BOX</b>	<b>14</b>
<b>PROPELLER SHAFTS</b>	<b>15</b>
<b>DIFFERENTIAL</b>	<b>16</b>
<b>SUSPENSION</b>	<b>17</b>
<b>STEERING SYSTEM</b>	<b>18</b>
<b>BRAKES</b>	<b>19</b>
<b>BODY SERVICE</b>	<b>20</b>
<b>BODY ELECTRICAL EQUIPMENT</b>	<b>21</b>
<b>SERVICE DATA</b>	<b>22</b>

# SECTION 0

## GENERAL, SPECIAL TOOLS AND SERVICE MATERIALS

### CONTENTS

0-1.	IDENTIFICATION NUMBER .....	0-1
0-2.	STANDARD SHOP PRACTICES .....	0-2
0-3.	SPECIAL TOOLS.....	0-5
0-4.	REQUIRED SERVICE MATERIALS .....	0-9
0-5.	METRIC INFORMATION .....	0-12

### O-I. IDENTIFICATION NUMBER

#### VEHICLE IDENTIFICATION NUMBER

The vehicle identification number is on the instrument panel left side.  
Refer to below figure for detailed VIN cord information and its location.

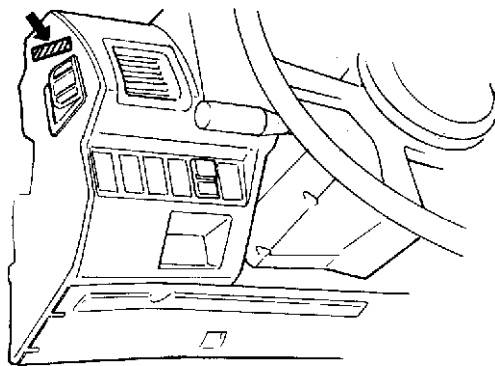
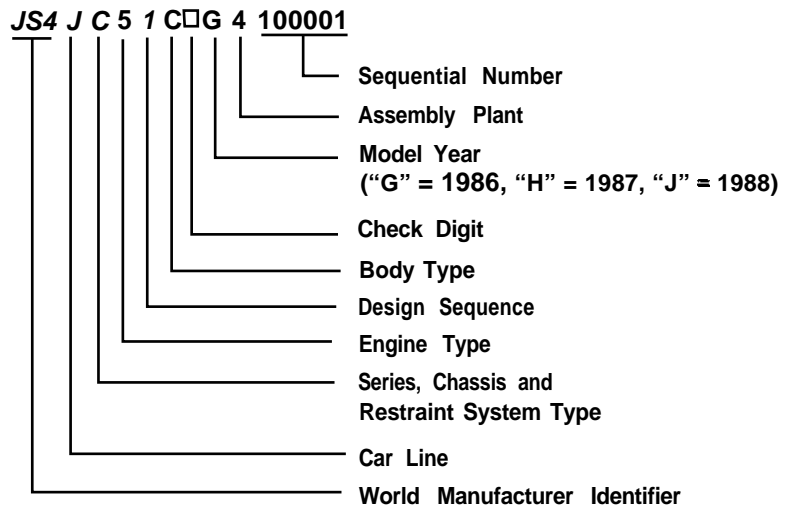


Fig. O-1



#### ENGINE IDENTIFICATION NUMBER

The engine number is punched on the rear portion of the left-hand skirt part of cylinder block.

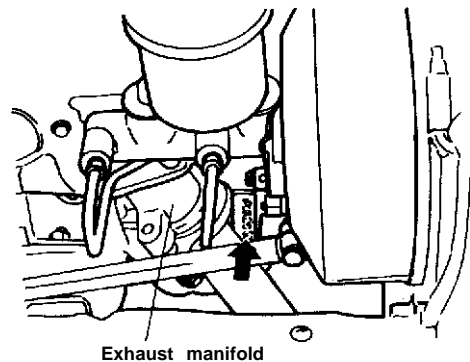


Fig. O-2 Location of Engine No.

## O-2. STANDARD SHOP PRACTICES

1. Protect painted surfaces of the body, and avoid staining or tearing seats. When working on fenders and seats, be sure to cover them up with sheets.
2. Disconnect negative terminal connection of the battery when working on any electrical part or component. This is necessary for avoiding electrical shocks and short-circuiting, and is very simple to accomplish: merely loosen wing nut on negative terminal and separate cable from terminal post.
3. In raising front or rear car end off the floor by jacking, be sure to put the jack against differential portion of axle housing.

### NOTE:

Don't get on the car, get under it or service it in this state.

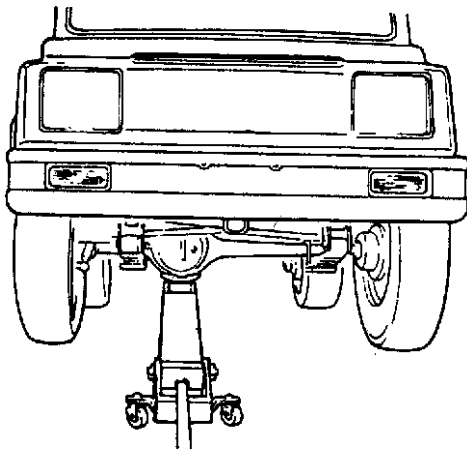


Fig. O-3 Front Side

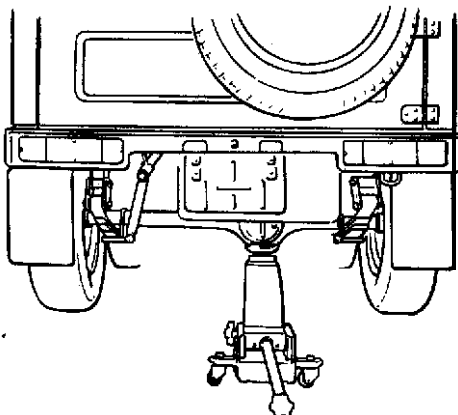


Fig. O-4 Rear Side

4. To perform service with either front or rear car end jacked up, be sure to place safety stands under chassis frame so that body is securely supported. Refer to below figures for where to place safety stands. And then check to ensure that chassis frame does not slide on safety stands and the car is held stable for safety's sake.

### WARNING:

Place chocks against both right and left wheels on the ground from both front and rear.

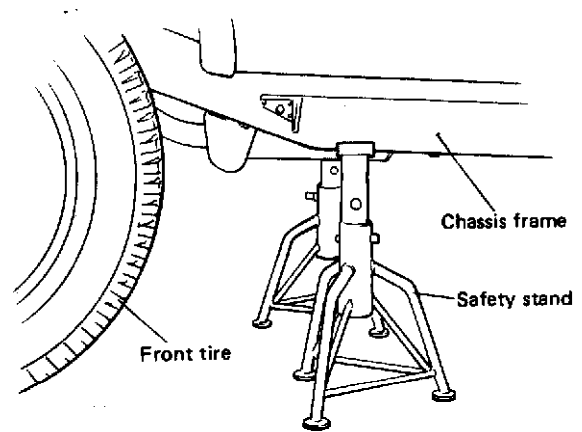


Fig. O-5 Front Side

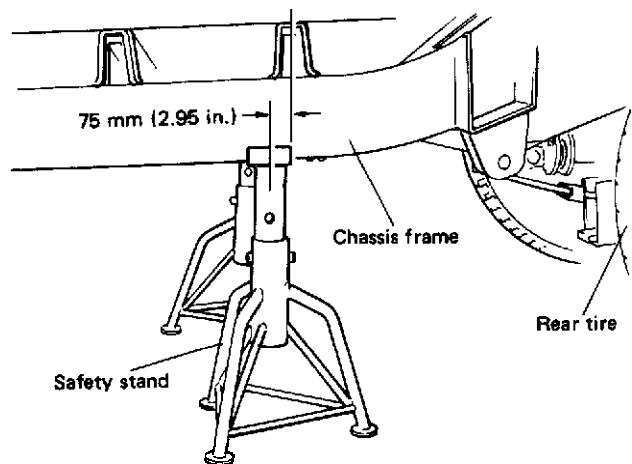


Fig. O-6 Rear Side

5. Fig. O-7 and O-8 show how to lift the car by using a hoist.

**WARNING:**

- When using frame contact hoist, apply hoist as shown below (right and left at the same position), Lift up the car till 4 tires are a little off the ground and make sure that the car will not fall off by trying to move car body in both ways. Work can be started only after this confirmation.
- Before applying hoist to underbody, always take car balance throughout service into consideration. Car balance on hoist may change depending of what part to be removed.
- For suspension parts removal, follow previous steps 3 and 4.
- Make absolutely sure to lock hoist after car is hoisted up.

When using frame contact hoist:

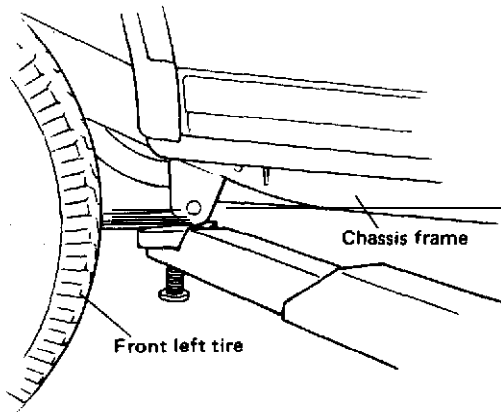


Fig. O-7 Front Support Location

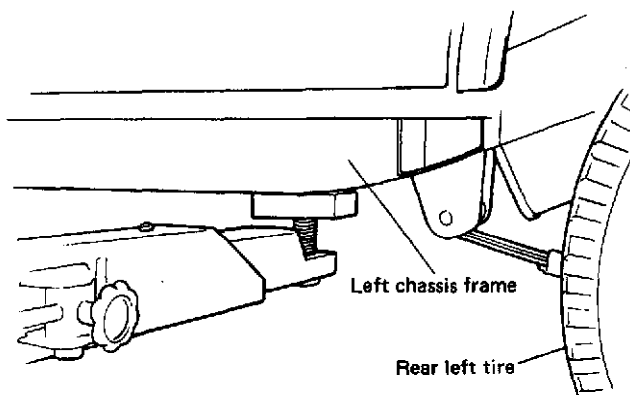


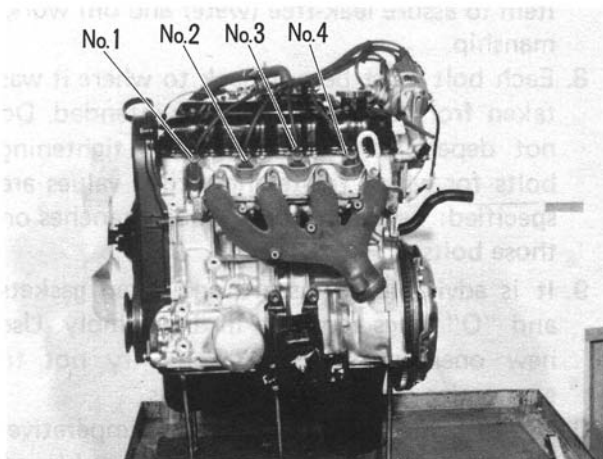
Fig. O-8 Rear Support Location

6. Orderliness is a key to successful overhauling. Trays, pans and shelves are needed to set aside disassembled parts in groups or sets in order to avoid confusion and misplacement. This is particularly important for engine overhauling.
7. Have on hand liquid packing-SUZUKI BOND No. 1215 (99000-31110) – for ready use. This packing dope is an essential item to assure leak-free (water and oil) workmanship.
8. Each bolt must be put back to where it was taken from or for which it is intended. Do not depend on your hunch in tightening bolts for which tightening torque values are specified: be sure to use torque wrenches on those bolts.
9. It is advisable to discard and scrap gaskets and “O” rings removed in disassembly. Use new ones in reassembly, and try not to economize gaskets and “O” rings.
10. Use of genuine SUZUKI parts is imperative. Use of imitation parts is a big gamble on safety and performance. Use genuine SUZUKI parts and live up to the trust your customer places on you.
11. Special tools save time and ensure good workmanship: They are available from SUZUKI. Use them where their use is specified. Moreover, your own safety is assured by the use of special tools in many of the disassembly and reassembly steps.

12. Refer to the contents of this **MANUAL** as often as practical, and do each job properly as prescribed.

**NOTE:**

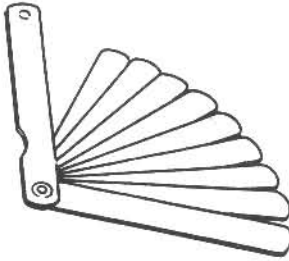
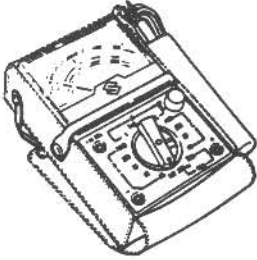
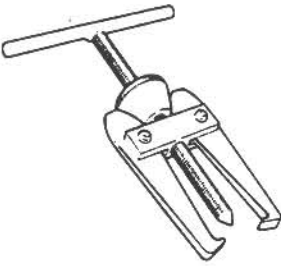
Engine cylinders are identified by numbers. See Fig. O-9. Counting from the front end, the cylinders are referred to as No. 1, No. 2, No. 3 and No. 4 cylinders.



**Fig. O-9 Engine Cylinder Numbers**




### O-3. SPECIAL TOOLS

Special tools assure three things: 1) improved workmanship; 2) speedy execution of jobs for which they are meant; and 3) protection of parts and components against damage. Here are the special tools prescribed for this Model:

 <p>09900-06107 Snap ring plier (opening type)</p>	 <p>09900-06108 Snap ring plier (closing type)</p>	 <p>09900-20803 Thickness gauge</p>	 <p>09900-25002 Pocket tester</p>
 <p>09900-27311 Timing light (Dry cell type)</p>	 <p>09900-27301 Timing light (D.C. 12V)</p>	 <p>1. 09927-18410 Universal puller 2. 09921-57810 Bearing remover</p>	 <p>09913-75510 Bearing installer</p>
 <p>09913-60910 Bearing puller</p>	 <p>09915-47310 Oil filter wrench</p>	 <p>1. 09916-14510 Valve lifter 2. 09916-48210 Valve lifter attachment</p>	 <p>09926-48010 Universal joint assembler</p>

## 0-4. REQUIRED SERVICE MATERIALS

The materials listed below are needed for maintenance work on these cars, and should be kept on hand for ready use. In addition, such standard materials as cleaning fluids, lubricants, etc., should also be available. Methods and time of use are discussed in the text of this manual on later pages.

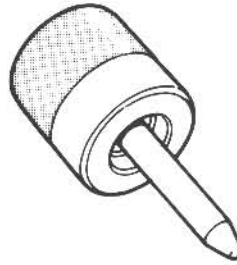
Ref. No.	Material		Use
1.	SUZUKI GOLDEN CRUISER 1200 "Anti-freeze/Anti-corrosion Coolant"		Additive to engine cooling system for improving cooling efficiency and for protection of wet walls against rusting.
2.	SUZUKI SUPER GREASE A (99000-25010)		<ul style="list-style-type: none"> <li>● For locations indicated in the section dealing with the starter motor.</li> <li>● Clutch release bearing retainer.</li> <li>● Clutch release shaft bushing.</li> <li>● Transmission oil seal.</li> <li>● Differential oil seal.</li> <li>● Wheel bearings.</li> <li>● Gear shifting control lever bushing &amp; seat.</li> <li>● Door window regulators.</li> <li>● For other locations specifically indicated in the text of this manual.</li> </ul>
3.	SUZUKI GREASE SUPER H (99000-25120)		Special grease intended for use on constant velocity joints.
4.	SUZUKI BOND NO. 1215 (99000-31110)		<ul style="list-style-type: none"> <li>● For top and bottom mating faces of transmission case.</li> <li>● For other locations specifically indicated in the text of this manual.</li> </ul>



09916-44511  
Valve guide remover



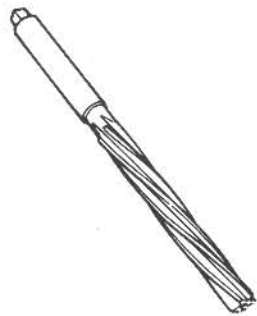
09917-88210  
Valve guide installer



09917-98210  
Valve stem seal installer



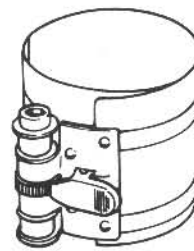
09916-34520  
Reamer (7 mm)



09916-37310  
Reamer (12 mm)



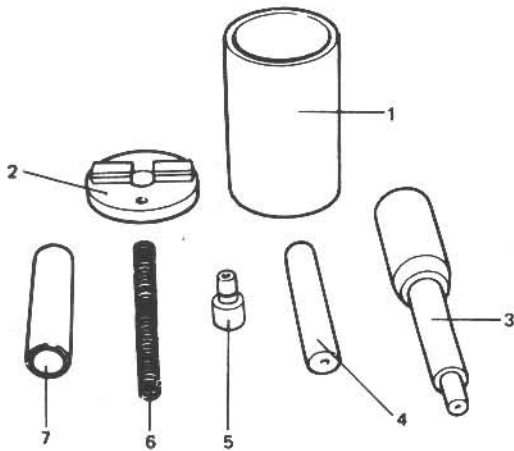
09916-34541  
Reamer handle



09916-77310  
Piston ring compressor



09916-84510  
Forceps

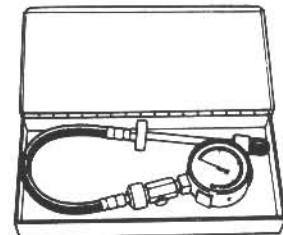


09910-38210  
Piston pin remover and installer

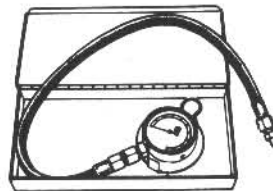
- 1. Base
- 2. Base cap
- 3. Driver handle
- 4. Piston pin guide for installation
- 5. Piston pin guide for removal
- 6. Spring
- 7. Spring guide



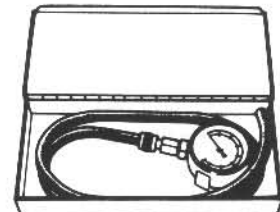
09916-57321  
Valve guide installer handle



09915-64510  
Compression gauge

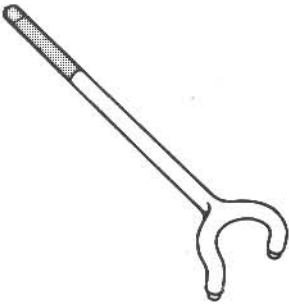
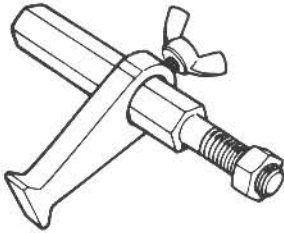
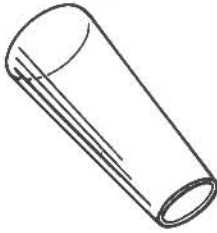

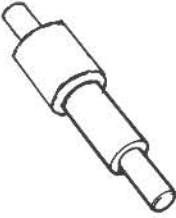
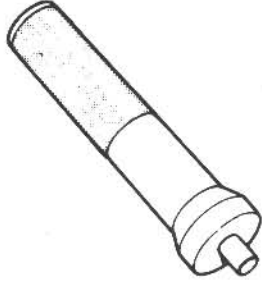
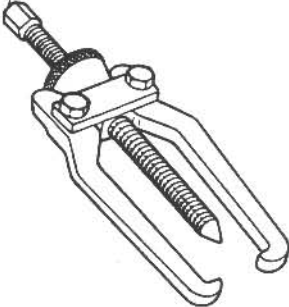

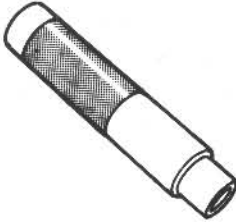
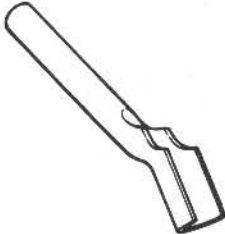

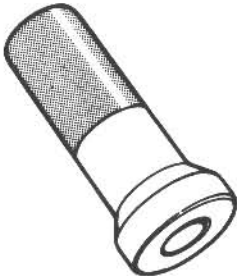
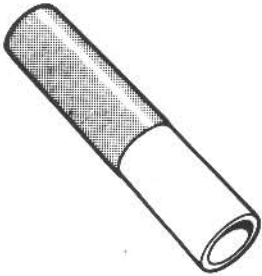

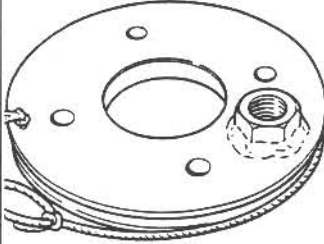



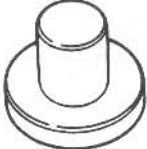
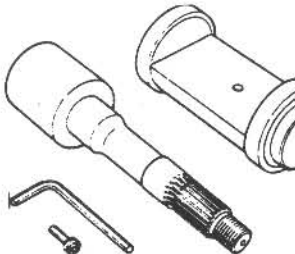




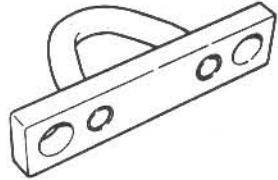

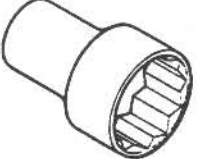
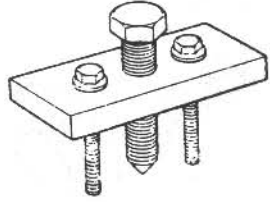
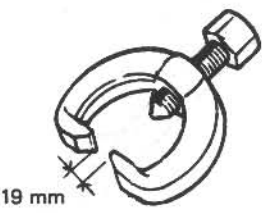
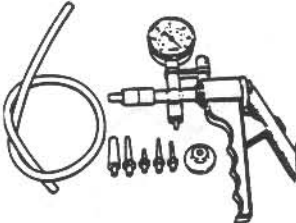

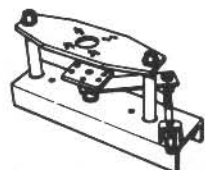
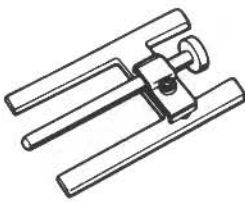
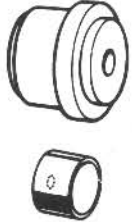
09915-77310  
Oil pressure gauge



09915-67310  
Vacuum gauge






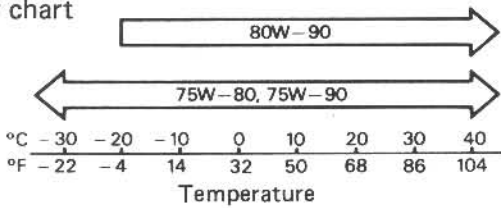
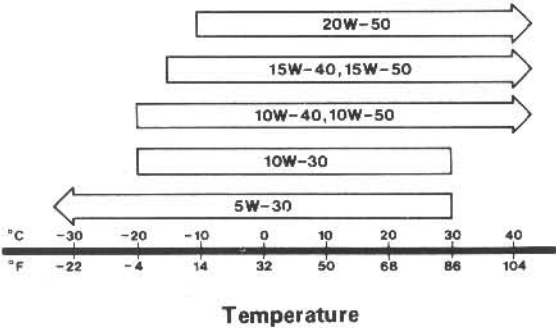
 <p>09917-68210 Camshaft lock holder</p>	 <p>09924-17810 Flywheel holder</p>	 <p>09926-18210 Oil seal guide (Vinyl resin)</p>	 <p>09917-58010 Bearing remover (for input shaft bearing)</p>
 <p>09923-38220 Clutch center guide</p>	 <p>09925-98210 Input shaft bearing installer</p>	 <p>09913-65135 Transmission and transfer bearing and gear remover</p>	 <p>09922-85811 Spring pin remover (4.5 mm)</p>
 <p>09925-18010 Transmission gear, bush and bearing installer</p>	 <p>09925-48210 Clutch release bush remover</p>	 <p>09913-75810 Transfer bearing installer</p>	 <p>09913-76010 Transfer bearing installer</p>
 <p>09913-84510 Transfer bearing installer</p>	 <p>09930-40113  <ul style="list-style-type: none"> <li>• Transfer flange lock holder</li> <li>• Differential side bearing adjuster</li> </ul> </p>	 <p>09922-75221  <ul style="list-style-type: none"> <li>• Differential bearing preload checking tool</li> </ul> </p>	 <p>09926-58010 Bearing puller attachment (transfer)</p>



 <p>09913-85230 Differential side bearing remover jig</p>	 <p>09926-78310 Differential bevel pinion mounting dummy</p>	 <p>09940-53111 Differential side bearing installer</p>	 <p>09924-74510 Bearing installer attachment</p>
 <p>09926-68310 Differential pinion bearing installer</p>	 <p>09942-15510 Sliding hammer</p>	 <p>09922-66010 Rear axle shaft remover</p>	 <p>09943-35511 Brake drum remover</p>
 <p>09941-58010 50 mm socket wrench</p>	 <p>09944-36010 Steering wheel remover</p>	 <p>09913-65210 Tie-rod end remover</p>	 <p>09917-47910 Vacuum pump gauge</p>
 <p>09950-78210 Flare nut wrench (10 mm)</p>	 <p>09950-88210 Booster overhaul tool set</p>	 <p>09950-98210 Booster piston rod gauge</p>	 <p>No. 1 09951-08210</p> <p>No. 2 09951-18210</p> <p>Booster No. 2 body Oil seal remover &amp; Installer No. 1, No. 2</p>

## 0-4. REQUIRED SERVICE MATERIALS

The materials listed below are needed for maintenance work on these cars, and should be kept on hand for ready use. In addition, such standard materials as cleaning fluids, lubricants, etc., should also be available. Methods and time of use are discussed in the text of this manual on later pages.

Ref. No.	Material		Use
1.	SUZUKI GOLDEN CRUISER 1200 "Anti-freeze/Anti-corrosion Coolant"		Additive to engine cooling system for improving cooling efficiency and for protection of wet walls against rusting.
2.	SUZUKI SUPER GREASE A (99000-25010)		<ul style="list-style-type: none"> <li>● For locations indicated in the section dealing with the starter motor.</li> <li>● Clutch release bearing retainer.</li> <li>● Clutch release shaft bushing.</li> <li>● Transmission oil seal.</li> <li>● Differential oil seal.</li> <li>● Wheel bearings.</li> <li>● Gear shifting control lever bushing &amp; seat.</li> <li>● Door window regulators.</li> <li>● For other locations specifically indicated in the text of this manual.</li> </ul>
3.	SUZUKI GREASE SUPER H (99000-25120)		Special grease intended for use on constant velocity joints.
4.	SUZUKI BOND NO. 1215 (99000-31110)		<ul style="list-style-type: none"> <li>● For top and bottom mating faces of transmission case.</li> <li>● For other locations specifically indicated in the text of this manual.</li> </ul>

5.	<p>CHASSIS GREASE</p>	<ul style="list-style-type: none"> <li>• For grease nipples on propeller shafts.</li> <li>• For propeller shaft splines.</li> </ul>												
6.	<p><b>GEAR OIL Oil Grade</b></p> <table border="1" data-bbox="245 562 667 716"> <tr> <td colspan="2"></td> <td>API GRADE</td> </tr> <tr> <td colspan="2">Transmission</td> <td rowspan="2">GL-4 or 5</td> </tr> <tr> <td colspan="2">Transfer</td> </tr> <tr> <td rowspan="2">Differential</td> <td>Front</td> <td rowspan="2">GL-5</td> </tr> <tr> <td>Rear</td> </tr> </table> <p>Viscosity chart SAE</p>  <p>Temperature</p>			API GRADE	Transmission		GL-4 or 5	Transfer		Differential	Front	GL-5	Rear	<ul style="list-style-type: none"> <li>• Transmission case 1.3 ltr. (2.7/2.3 US/Imp. pt.)</li> <li>• Transmission gear and bearing</li> <li>• Transfer case 0.8 ltr. (1.7/1.4 US/Imp. pt.)</li> <li>• Steering gear box</li> <li>• Differential gear box (Hypoid gear oil) Rear 1.5 ltr. (3.2/2.6 US/Imp. pt.) Front 2.0 ltr. (4.2/3.5 US/Imp. pt.)</li> </ul>
		API GRADE												
Transmission		GL-4 or 5												
Transfer														
Differential	Front	GL-5												
	Rear													
7.	<p>SEALANT (99000-31150)</p>	<ul style="list-style-type: none"> <li>• For mating surfaces of engine oil pan and cylinder block.</li> </ul>												
8.	<p><b>4-STROKE ENGINE OIL</b> It is recommended to use engine oil of SE, or SF class.</p> <p><b>Proper Engine Oil Viscosity Chart</b></p>  <p>Temperature</p>	<ul style="list-style-type: none"> <li>• For engine oil pan: (For periodical oil change)</li> <li>• Crank journal bearings and thrust plate.</li> <li>• Connecting-rod big-end and small-end bearings.</li> <li>• Camshaft journals.</li> <li>• Rocker shafts.</li> <li>• Oil pump gears.</li> <li>• Pistons and piston rings.</li> <li>• Engine oil seals.</li> <li>• Valve stems.</li> <li>• Accelerator and clutch cables.</li> <li>• Parking brake cable.</li> <li>• Accelerator, brake and clutch pedal shafts.</li> <li>• Door locks and hinges.</li> <li>• Distributor gear.</li> </ul>												

9.	SEALING COMPOUND "CEMEDINE" 366E (Water tight sealant) (99000-31090) 180 ml		<ul style="list-style-type: none"> <li>• King pin shim face.</li> <li>• For steering knuckle (rear axle housing) and brake packing plate mating surface.</li> <li>• For other locations specifically indicated in the text of this manual.</li> </ul>
10.	THREAD LOCK CEMENT SUPER 1333B (99000-32020)		<ul style="list-style-type: none"> <li>• Transmission reverse gear shift rim bolt.</li> <li>• Gear shift lever locating bolt.</li> <li>• Differential drive bevel gear bolt.</li> </ul>
11.	BRAKE FLUID "DOT3"		<ul style="list-style-type: none"> <li>• To fill master cylinder reservoir.</li> <li>• To clean and apply to inner parts of master cylinder, caliper and wheel cylinder when they are disassembled.</li> </ul>
12.	SILICONE GREASE (Furnished in repair kit)		<ul style="list-style-type: none"> <li>• To apply to brake booster inner parts where application is instructed in this manual.</li> </ul>
13.	THREAD LOCK CEMENT "1342" (99000-32050)		<ul style="list-style-type: none"> <li>• King pin bolt</li> </ul>
14.	SUZUKI SUPER GREASE I (99000-25210)		<ul style="list-style-type: none"> <li>• Transmission input shaft</li> </ul>

## O-5. METRIC INFORMATION

### METRIC FASTENERS

Most of the fasteners used for this vehicle are metric. When replacing any fasteners, it is most important that replacement fasteners be the correct diameter, thread pitch and strength.

### FASTENER STRENGTH IDENTIFICATION

Most commonly used metric fastener strength property classes are 4T, 7T and radial line with the class identification embossed on the head of each bolt. Some metric nuts will be marked with punch mark strength identification on the nut face. Fig. 0-10 shows the different strength markings.

When replacing metric fasteners, be careful to use bolts and nuts of the same strength or greater than the original fasteners (the same number marking or higher). It is likewise important to select replacement fasteners of the correct size. Correct replacement bolts and nuts are available through the parts department.

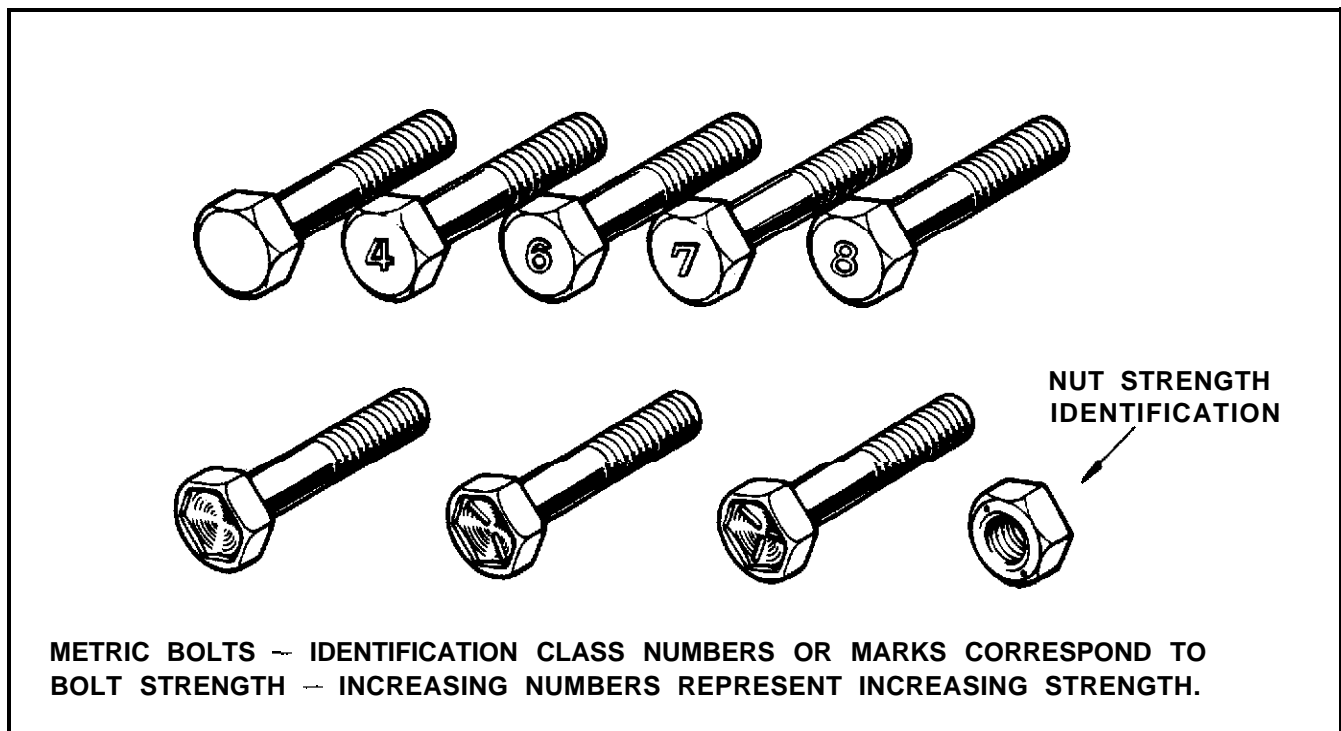


Fig. 0-10 Bolt Strength Markings

## STANDARD TIGHTENING TORQUE

Each fastener should be tightened to the torque specified in each section of this manual. If no description or specification is provided, refer to the following tightening torque chart for the applicable torque for each fastener. When a fastener of greater strength than the original one is used, however, use the torque specified for the original fastener.

### NOTE:

- For the flanged bolt and nut, add 10% to the tightening torque given in the below chart
- The below chart is applicable only where the fastened parts are made of steel or light alloy.

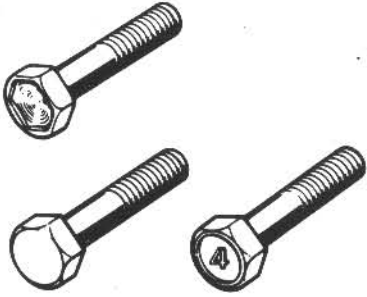
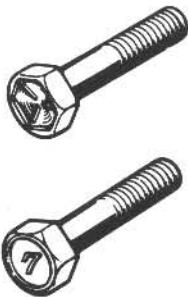
STRENGTH  THREAD DIAMETER (mm)	 Conventional bolt "4T" bolt			 "7T" bolt		
	N·m	kg·m	lb·ft	N·m	kg·m	lb·ft
4	1 – 2	0.1 – 0.2	0.7 – 1.0	1.5 – 3.0	0.15 – 0.30	1.5 – 2.0
5	2 – 4	0.2 – 0.4	1.5 – 3.0	3 – 6	0.3 – 0.6	2.5 – 4.0
6	4 – 7	0.4 – 0.7	3.0 – 5.0	8 – 12	0.8 – 1.2	6.0 – 8.5
8	10 – 16	1.0 – 1.6	7.5 – 11.5	18 – 28	1.8 – 2.8	13.5 – 20.0
10	22 – 35	2.2 – 3.5	16.0 – 25.0	40 – 60	4.0 – 6.0	29.0 – 43.0
12	35 – 55	3.5 – 5.5	25.5 – 39.5	70 – 100	7.0 – 10.0	51.0 – 72.0
14	50 – 80	5.0 – 8.0	36.5 – 57.5	110 – 160	11.0 – 16.0	80.0 – 115.5
16	80 – 130	8.0 – 13.0	58.0 – 94.0	170 – 250	17.0 – 25.0	123.0 – 180.5
18	130 – 190	13.0 – 19.0	94.5 – 137.0	200 – 280	20.0 – 28.0	145.0 – 202.5

Fig. 0-11 Tightening Torque Chart

## SECTION 1

# PERIODIC MAINTENANCE SERVICE

1

### CONTENTS

1-1. MAINTENANCE SCHEDULE.....	1-2
1-2. ENGINE AND EMISSION CONTROL .....	1-5
1-3. CHASSIS AND BODY .....	1-17





Interval: This interval should be judged by odometer reading or months, whichever comes first.	miles (x 1,000)		7.5		15		22.5		30		37.5		45		52.5		60		67.5		75		82.5		90		97.5		105		112.5		120					
	km (x 1,000)		12		24		36		48		60		72		84		96		108		120		132		144		156		168		180		192					
	months		6		12		18		24		30		36		42		48		54		60		66		72		78		84		90		96					
21. Fuel tank cap	-	-	-	-	**I(I)	-	-	-	-	-	R	-	-	-	-	-	-	-	-	-	-	-	-	-	-	-	-	-	-	-	-	-	R	-				
22. Air cleaner filter element	-	-	-	-	R	-	-	-	-	-	R	-	-	-	-	-	-	-	R	-	-	-	-	-	-	-	-	-	-	-	-	-	R	-				
23. Thermostatically controlled air cleaner system	-	-	-	-	-	-	-	-	-	-	-	-	-	-	-	-	-	-	-	-	-	-	-	-	-	-	-	-	-	-	-	-	-	-	-	-		
24. Choke system	-	-	-	-	-	-	-	-	I&L	-	-	-	-	-	-	-	I&L	-	-	-	-	-	-	-	-	-	-	-	-	-	-	-	-	-	I&L	-		
25. Fuel filter	-	-	-	-	-	-	-	-	**R(R)	-	-	-	-	-	-	-	R	-	-	-	-	-	-	-	-	-	-	-	-	-	-	-	-	-	R	-		
26. Fuel lines and connections	-	-	-	-	-	-	-	-	**I(I)	-	-	-	-	-	-	-	R	-	-	-	-	-	-	-	-	-	-	-	-	-	-	-	-	-	R	-		
*27. Idle speed	-	-	-	-	-	-	-	-	-	-	-	-	-	-	-	-	-	-	-	-	-	-	-	-	-	-	-	-	-	-	-	-	-	-	-	-		
28. Idle mixture	-	-	-	-	-	-	-	-	-	-	-	-	-	-	-	-	-	-	-	-	-	-	-	-	-	-	-	-	-	-	-	-	-	-	-	-		
29. Carburetor	Inspect at 100,000 miles (160,000 km)																																					
<b>CHASSIS AND BODY</b>																																						
30. Clutch	-	-	-	-	-	-	-	-	-	-	-	-	-	-	-	-	-	-	-	-	-	-	-	-	-	-	-	-	-	-	-	-	-	-	-	-	-	-
31. Brake discs and pads (front)	-	-	-	-	-	-	-	-	-	-	-	-	-	-	-	-	-	-	-	-	-	-	-	-	-	-	-	-	-	-	-	-	-	-	-	-	-	-
31. Brake drums and shoes (rear)	-	-	-	-	-	-	-	-	-	-	-	-	-	-	-	-	-	-	-	-	-	-	-	-	-	-	-	-	-	-	-	-	-	-	-	-	-	-
32. Brake hoses and pipes	-	-	-	-	-	-	-	-	-	-	-	-	-	-	-	-	-	-	-	-	-	-	-	-	-	-	-	-	-	-	-	-	-	-	-	-	-	-
33. Brake fluid	-	-	-	-	-	-	-	-	-	-	-	-	-	-	-	-	R	-	-	-	-	-	-	-	-	-	-	-	-	-	-	-	-	-	-	-	-	-
34. Brake pedal	-	-	-	-	-	-	-	-	-	-	-	-	-	-	-	-	-	-	-	-	-	-	-	-	-	-	-	-	-	-	-	-	-	-	-	-	-	-
35. Brake lever and cable	-	-	-	-	-	-	-	-	-	-	-	-	-	-	-	-	-	-	-	-	-	-	-	-	-	-	-	-	-	-	-	-	-	-	-	-	-	-
36. Tires	I	I	I	I	I	I	I	I	I	I	I	I	I	I	I	I	I	I	I	I	I	I	I	I	I	I	I	I	I	I	I	I	I	I	I	I	I	I
37. Wheel discs and free wheeling hubs (if equipped)	I	I	I	I	I	I	I	I	I	I	I	I	I	I	I	I	I	I	I	I	I	I	I	I	I	I	I	I	I	I	I	I	I	I	I	I	I	I
38. Steering knuckle oil seals	-	-	-	-	-	-	R	-	-	-	-	-	-	-	-	-	-	-	-	-	-	-	-	-	-	-	-	-	-	-	-	-	-	-	-	-	R	-
39. Wheel bearings	-	-	-	-	-	-	-	-	-	-	*I	-	-	-	-	-	-	-	-	-	-	-	-	-	-	-	-	-	-	-	-	-	-	-	-	-	-	-
40. Shock absorbers	I	I	I	I	I	I	I	I	I	I	I	I	I	I	I	I	I	I	I	I	I	I	I	I	I	I	I	I	I	I	I	I	I	I	I	I	I	I
41. Propeller shafts	-	-	I&L	-	-	-	-	-	-	-	-	-	-	-	-	-	-	-	-	-	-	-	-	-	-	-	-	-	-	-	-	-	-	-	-	-	-	-
42. Transmission, transfer and differential oil	R	I	I	I	R	I	I	I	R	I	I	I	R	I	I	I	R	I	I	I	R	I	I	I	R	I	I	I	R	I	I	I	R	I	I	I	R	I
43. Leaf springs	-	-	-	-	-	-	-	-	-	-	-	-	-	-	-	-	-	-	-	-	-	-	-	-	-	-	-	-	-	-	-	-	-	-	-	-	-	-
44. Bolts and nuts	T	T	-	-	-	-	-	-	T	-	-	-	-	-	-	-	T	-	-	-	-	-	-	-	-	-	-	-	-	-	-	-	-	-	-	-	-	-
45. Steering system	I	I	I	I	I	I	I	I	I	I	I	I	I	I	I	I	I	I	I	I	I	I	I	I	I	I	I	I	I	I	I	I	I	I	I	I	I	I
46. Door hinges	L	L	L	L	L	L	L	L	L	L	L	L	L	L	L	L	L	L	L	L	L	L	L	L	L	L	L	L	L	L	L	L	L	L	L	L	L	L

**NOTES:**

"R": Replace or change

"I": Inspect and correct or replace if necessary

"T": Tighten to the specified torque

"L": Lubricate

[ ]: Applicable to Canadian specification vehicle.

[\*]: (For U.S.A. specification vehicle) Item 21 \*\*I, Item 25 \*\*R and Item 26 \*\*I are recommended maintenance items.

[\*]: Item 26 R is applicable to the fuel hose and clamp only.

[\*]: Item \*27 is recommended maintenance item.

[\*]: Item 39 \*I is applicable to not only rattled wear but also their grease.

## MAINTENANCE RECOMMENDED UNDER SEVERE DRIVING CONDITIONS

If the car is usually used under the conditions corresponding to any severe condition code given below, it is recommended that applicable maintenance operation be performed at the particular interval as given in the below chart.

Severe condition code

A - Towing a trailer

B - Repeated short trips

C - Driving on rough and/or muddy roads

D - Driving on dusty roads

E - Driving in extremely cold weather and/or salted roads

F - Repeated short trips in extremely cold weather

Severe Condition Code	Maintenance	Maintenance Operation	Maintenance Interval
A - - D E F	Engine oil and oil filter	R	Every 3 750 miles (6 000 km) or 3 months
A B C - E →	Exhaust pipes and mountings	I	Every 7 500 miles (12 000 km) or 6 months
- - - D - -	Air cleaner filter element *1	I	Every 3 750 miles (6 000 km) or 3 months
		R	Every 15 000 miles (24 000 km) or 12 months
- - - - E →	Choke system (Carburetor shafts)	I & L	Every 7 500 miles (12 000 km) or 6 months
- - - - E →	Distributor cap and Ignition wiring *2	I	Every 15 000 miles (24 000 km) or 12 months
A B C D - -	Brake discs and pads (Front) Brake drums and shoes (Rear)	I	Every 7 500 miles (12 000 km) or 6 months
A B C - - -	Propeller shafts	I & L	Every 7 500 miles (12 000 km) or 6 months
A - C - - -	Transmission, transfer and differential oil	R	Every 15 000 miles (24 000 km) or 12 months After first replacement at 7 500 miles (12 000 km)
- - C - - -	Leaf springs	I	Every 15 000 miles (24 000 km) or 12 months
- - C - - -	Bolts and nuts on chassis	T	Every 7 500 miles (12 000 km) or 6 months
- - C - - -	Steering wheel free play, gear box oil and linkage	I	Every 3 750 miles (6 000 km) or 3 months
- - C - E →	Steering knuckle oil seals	R	Every 15 000 miles (24 000 km) or 12 months

### MOTES:

I - inspect and correct or replace if necessary

R - Replace or change

T - Tighten to the specified torque

L - Lubricate

\*1 Inspect more frequently if the vehicle is used under dusty conditions.

\*2 In areas where road salt is used, inspect and clean the distributor cap and ignition wiring more frequently.

## 1-2. ENGINE AND EMISSION CONTROL

### 1. WATER PUMP BELT INSPECTION AND REPLACEMENT

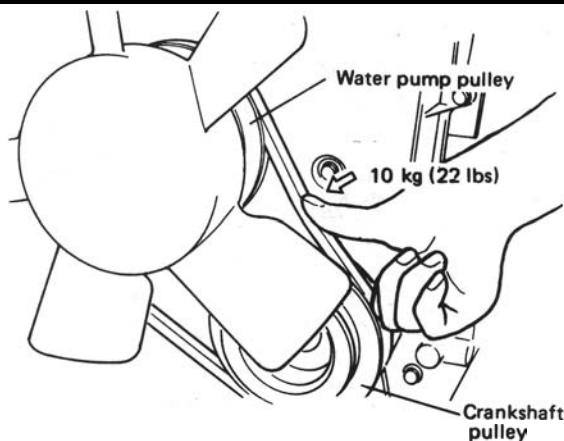
**WARNING:**

All inspection and replacement are to be performed with ENGINE NOT RUNNING.

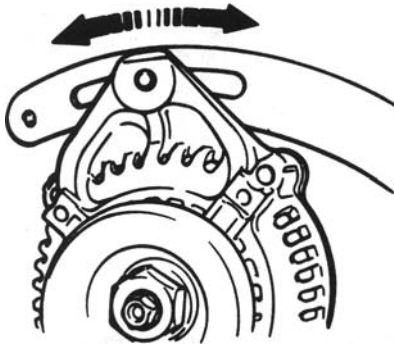
[INSPECTION]

- 1) Disconnect negative battery lead at battery.
- 2) Inspect belt for cracks, cuts, deformation, wear and cleanliness. If any defect, replace. Check belt for tension. The belt is in proper tension if it deflects 6 to 9 mm (0.24 – 0.35 in.) under thumb pressure (about 10 kg or 22 lb.).

Belt tension specification	6 – 9 mm (0.24 – 0.35 in.) as deflection
----------------------------	--



- 3) If the belt is too tight or too loose, adjust it to specification by adjusting alternator position.



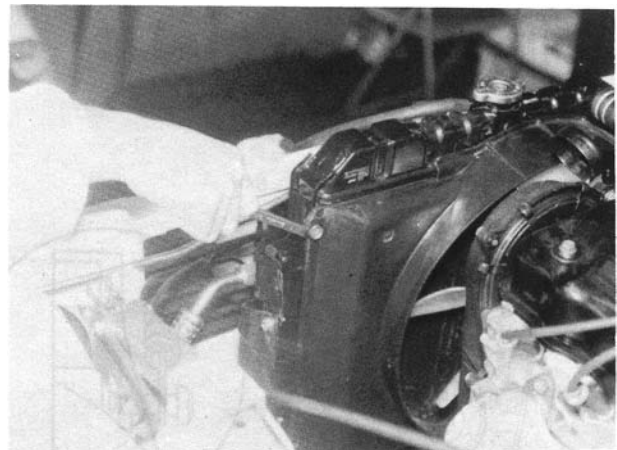
- 4) Tighten alternator adjusting bolt and pivot bolts.
- 5) Connect negative battery lead to battery.

[REPLACEMENT]

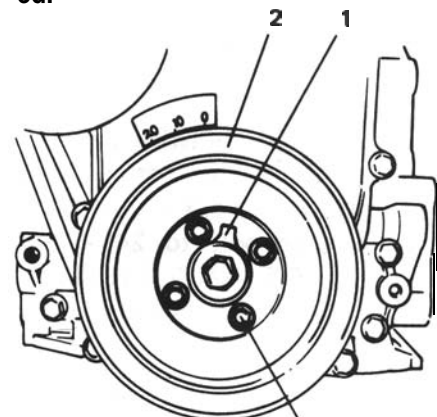
- 1) Disconnect negative battery lead at battery.
- 2) Loosen alternator adjusting bolt and pivot bolts.
- 3) Replace water pump belt.
- 4) Adjust belt tension to specification and tighten alternator adjusting bolt and pivot bolts.
- 5) Connect negative battery lead to battery.

### 2. CAMSHAFT TIMING BELT INSPECTION

- 1) Disconnect negative battery lead at battery.
- 2) Loosen fan drive belt, and remove 4 bolts securing radiator shroud panel and 4 nuts securing engine cooling fan & clutch. Then remove radiator shroud and cooling fan & clutch at the same time.



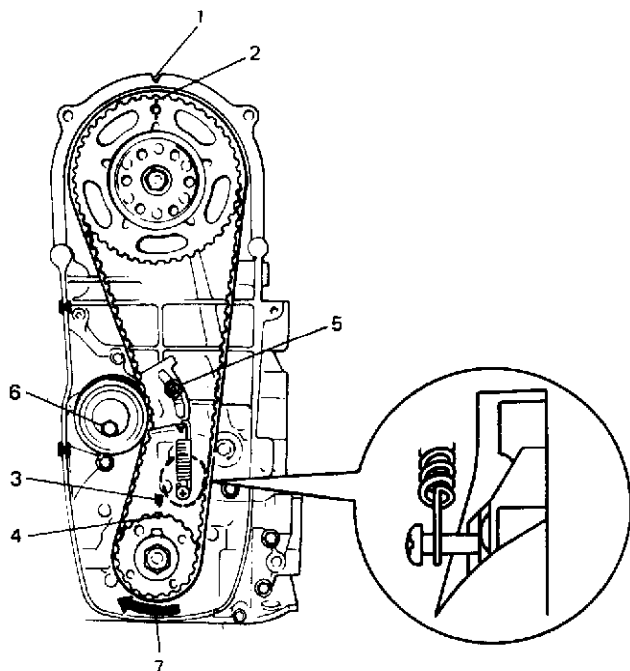
- 3) Remove water pump belt and pump pulley.
- 4) Remove crankshaft pulley by removing 4 pulley bolts. The crankshaft timing belt pulley bolt at the center need not be loosened.



1. Key
2. Crankshaft pulley
3. Pulley bolt

- 5) Remove timing belt outside cover. Inspect the belt for damage or wear. When any damage or wear is found on the belt, replace it.  
If belt replacement is necessary, be sure to install the belt properly.
- 6) Remove cylinder head cover and loosen all valve adjusting screws all the way to permit free rotation of camshaft.
- 7) Turn crankshaft clockwise and align 4 marks as shown.  
Loosen tensioner bolt and nut but do not remove.

- 9) Adjust valve lash to specification.
- 10) Install cylinder head cover and torque bolt to specification.
- 11) Install timing belt outside cover and torque bolts and nut to specification.
- 12) Install crankshaft pulley and torque bolts to specification.
- 13) Install water pump pulley and belt.
- 14) Install radiator shroud and cooling fan & clutch.
- 15) Adjust water pump belt tension to specification.
- 16) Connect negative battery lead to battery.



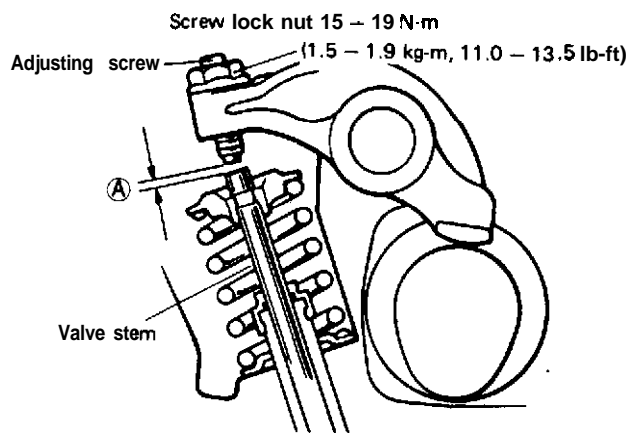
- |                |                      |
|----------------|----------------------|
| 1. "V" mark    | 5. Tensioner nut     |
| 2. Timing mark | 6. Tensioner bolt    |
| 3. Arrow mark  | 7. Turning direction |
| 4. Punch mark  |                      |

- 8) To allow belt to be free of any slack, turn crankshaft clockwise fully twice. After removing belt slack, tighten tensioner nut to 9 – 12 N·m (0.9 – 1.2 kg·m, 7.0 – 8.5 lb-ft) first and then tensioner bolt to 24 – 30 N·m (2.4 – 3.0 kg·m, 17.5 – 21.5 lb-ft). Then confirm again that 4 marks are matched.

### 3. VALVE LASH INSPECTION

- 1) Remove cylinder head cover.
- 2) Inspect intake and exhaust valve lash and adjust as necessary.

Valve lash specification		When cold (Coolant temperature is 15 – 25°C or 59 – 77°F)	When hot (Coolant temperature is 60-68°C or 140-154°F)
	Intake		0.13 - 0.17 mm (0.0051 - 0.0067 in)
Exhaust		0.16 - 0.20 mm (0.0063 - 0.0079 in)	0.26 - 0.30 mm (0.0102 - 0.0118 in)



- 3) Install cylinder head cover and tighten bolts to specification.

**NOTE:**

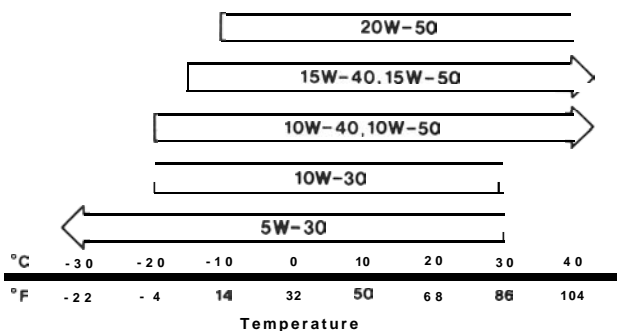
Steps 1) – 6) outlined above must be performed with **ENGINE NOT RUNNING**. For step 7), be sure to have adequate ventilation while engine is running

It is recommended to use engine oil of SE or SF class.

**NOTE:**

For temperatures below 32° F(0° C), it is highly recommended to use SAE 5W-30 oil.

**Proper Engine Oil Viscosity Chart**



**Engine Oil Viscosity Chart**

**Engine oil capacity**

Oil pan capacity	3.5 liters (7.4/6.2 US/Imp pt.)
Oil filter capacity	0.2 liters (0.4/0.3 US/Imp pt.)
Others	0.3 liters (0.6/0.5 US/Imp pt.)
<b>Total</b>	<b>4.0 liters</b> <b>(8.4/7.0 US/Imp pt.)</b>

8) Check oil filter and drain plug for oil leakage.

**5. COOLING SYSTEM HOSES AND CONNECTIONS INSPECTION**

1) Visually inspect cooling system hoses for any evidence of leakage and cracks. Examine them for damage, and check connection clamps for tightness.



2) Replace all hoses which show evidence of leakage, cracks or other damage. Replace all clamps which cannot maintain proper tightness.

**6. ENGINE COOLANT CHANGE**

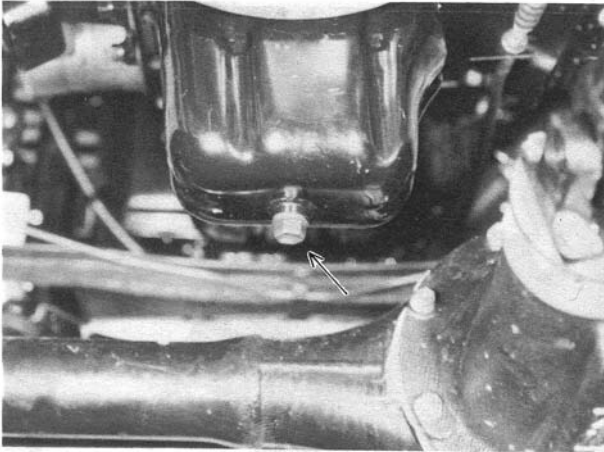
**WARNING:**  
To help avoid danger of being burned, do not remove radiator cap while engine and radiator are still hot. Scalding fluid and steam can be blown out under pressure if the cap is taken off too soon.

- 1) Remove radiator cap when engine is cool.
- 2) Loosen radiator drain plug ① to drain coolant.
- 3) Remove reservoir tank ②, which is on the side of radiator, and drain.
- 4) Tighten plug ① securely. Also reinstall reservoir tank.

#### 4. ENGINE OIL AND FILTER CHANGE

Before draining engine oil, check engine for oil leakage. If any evidence of leakage is found, make sure to correct defective part before proceeding to the following work.

1) Drain engine oil by removing drain plug.



2) After draining oil, wipe drain plug clean. Reinstall drain plug, and tighten it securely.

Tightening torque	N·m	kg·m	lb·ft
for oil drain plug	30-40	3.0-4.0	22.0-28.5

3) Loosen oil filter by using oil filter wrench "A" (special tool 09915-47310).



#### NOTE:

Before fitting new oil filter, be sure to oil its "O" ring. Use engine oil for this purpose.

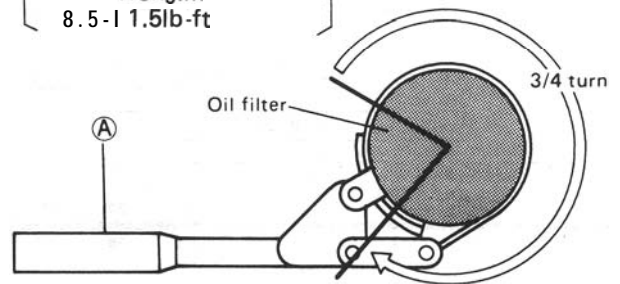
4) Screw new filter on oil filter stand by hand until the filter "O" ring contacts the mounting surface.

#### CAUTION:

To tighten the oil filter properly, it is important to accurately identify the position at which the filter "O" ring first contacts the mounting surface.

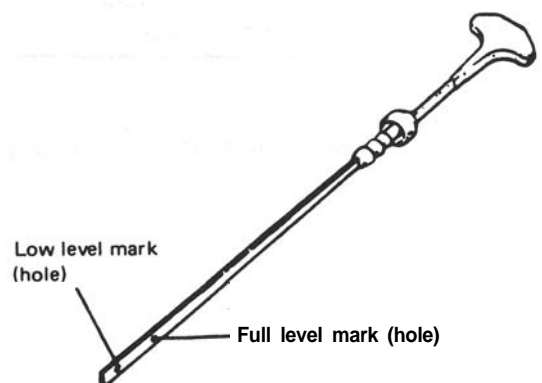
5) Tighten the filter 3/4 turn from the point of contact with the mounting surface using an oil filter wrench (A).

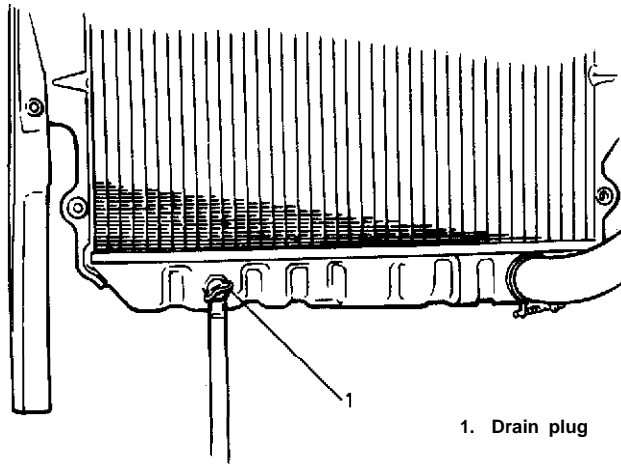
Oil filter tightening torque  
 12-16N·m  
 1.2-1.6kg·m  
 8.5-11.5lb·ft



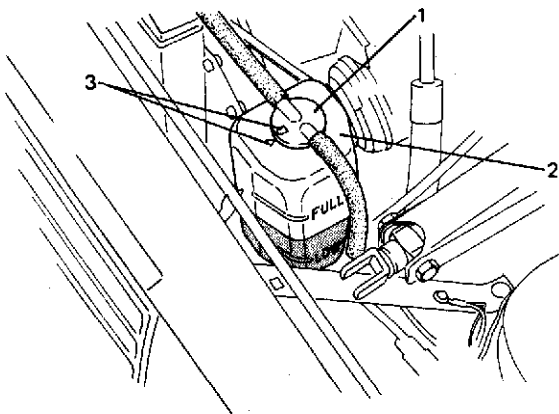
6) Replenish oil until oil level is brought to FULL level mark on dipstick. (about 3.7 liters or 7.8/6.5 US/Imp pt.). The filler inlet is atop the cylinder head cover.

7) Start engine and run it for three minutes. Stop engine and wait another three minutes before checking oil level. Add oil, as necessary, to bring oil level to FULL level mark on dipstick.





1. Drain plug



1. Reservoir tank cap  
2. Reservoir tank  
3. Arrow marks

- 5) Fill radiator with specified amount of coolant, and run engine for 2 or 3 minutes at idle. This drives out any air which may still be trapped within cooling system. STOP ENGINE. Add coolant as necessary until coolant level reaches the filler throat of radiator. Reinstall radiator cap.
- 6) Add coolant to reservoir tank so that the level aligns with Full mark. Then, reinstall cap aligning the arrow marks on the tank and cap.

COOLANT CAPACITY	
Engine, radiator and heater	4.2 liters (8.9/7.4 US/Imp pt.)
Reservoir tank	0.6 liters (1.3/1.1US/Imp pt.)
Total	4.8 liters (10.1/8.4 US/Imp pt.)

**CAUTION:**

When changing engine coolant, use mixture of 56% water and 50% GOLDEN CRUISER 1200 for the market where ambient temperature falls lower than -16°C (3°F) in winter and mixture of 70% water and 30% GOLDEN CRUISER 1200 for the market where ambient temperature doesn't fall lower than -16°C (3° F).

Even in a market where no freezing temperature is anticipated, mixture of 70% water and 30% GOLDEN CRUISER 1200 should be used for the purpose of corrosion protection and lubrication.

**7. EXHAUST PIPES AND MOUNTINGS INSPECTION**

**WARNING:**

To avoid danger of being burned, do not touch exhaust system when system is hot. Any service on exhaust system should be performed when system is cool.

When carrying out periodic maintenance, or the car is raised for other service, check exhaust system as follows:

- Check rubber mountings for damage, deterioration, and out of position.
- Check exhaust system for leakage, loose connections, dents, and damages.  
If bolts or nuts are loose, tighten them to specification. Refer to below chart for torque specification.
- Check nearby body areas for damaged, missing, or mispositioned parts, open seams, holes, loose connections or other defects which could permit exhaust fumes to seep into the car.
- Make sure that exhaust system components have enough clearance from the underbody to avoid overheating and possible damage to the floor carpet.
- Any defects should be fixed at once.

Bolts and nut	Tightening torque
Exhaust pipe bolts	40 – 60 N·m
	4.0 – 6.0 kg·m
	29.0 – 43.0 lb·ft
Muffler nuts	18 – 28 N·m
	1.8 – 2.8 kg·m
	13.5 – 20.0 lb·ft

Replace center pipe rubber mounting and muffler rubber mountings with new ones periodically.



## 8. PCV VALVE REPLACEMENT

- 1) Disconnect crankcase ventilation hose from PCV valve.
- 2) Remove PCV valve from intake manifold.
- 3) Wind sealing tape on thread of the new valve and install it securely.

Tightening torque for PCV valve	15 – 25 N·m 1.5 – 2.5 kg·m, 11.0 – 18.0 lb·ft
---------------------------------	---

- 4) Install hose and clamp it securely.

## 9. OXYGEN SENSOR REPLACEMENT

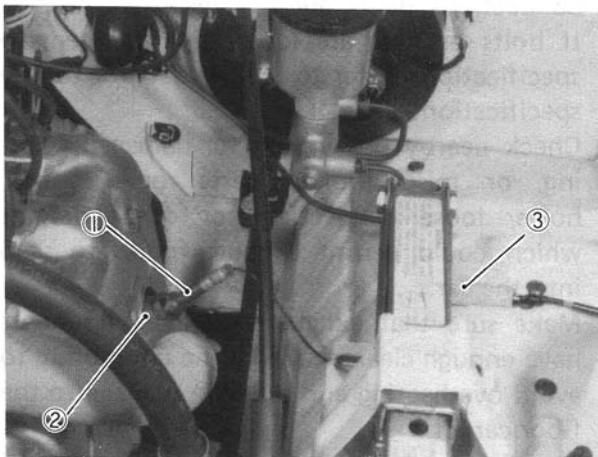
[Canadian specification vehicle]

When the odometer indicates 50,000 and 100,000 miles, replace oxygen sensor as follows.

### CAUTION:

To avoid the danger of being burned, do not touch the exhaust system when the system is hot. This work should be performed when the system is cool.

- 1) Disconnect battery negative cable from battery and disconnect oxygen sensor wire at the coupler.

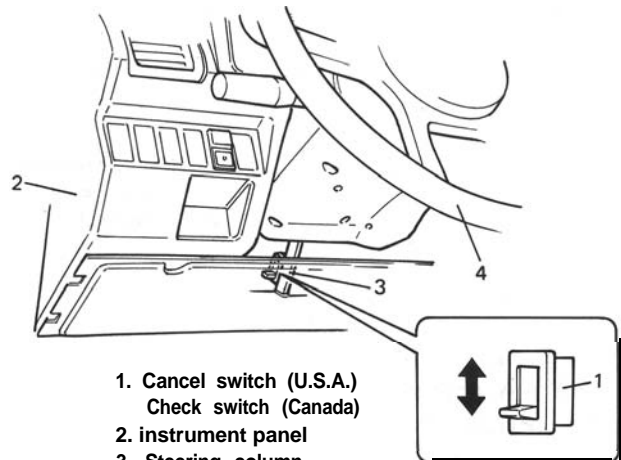


1. Oxygen sensor      3. Coupler  
2. Exhaust manifold

- 2) Remove oxygen sensor from exhaust manifold.
- 3) Install new gasket and oxygen sensor, and tighten it to specification.

Tightening torque for oxygen sensor	45 – 55 N·m 4.5 – 5.5 kg·m 33.0 – 39.5 lb·ft
-------------------------------------	--

- 4) Connect oxygen sensor- wire at the coupler securely and clamp its wire.
- 5) Connect negative cable to battery.
- 6) Start engine and check for gas leak.  
For Canadian specification vehicle, turn on check switch.
- 7) Run engine at 1,500 ~ 2,000 r/min for 30 sec. after warming up engine. Check to be sure that “CHECK ENGINE” light flashes, and turn off “CHECK ENGINE” light cancel/check switch on steering column holder bracket.



1. Cancel switch (U.S.A.)  
Check switch (Canada)  
2. instrument panel  
3. Steering column holder bracket  
4. Steering wheel

## 10. CATALYTIC CONVERTER INSPECTION

- 1) All accessories (wipers, heater, lights, etc.) are out of service.
- 2) Warm up engine to normal operating temperature.
- 3) Connect CO tester to muffler tail pipe.
- 4) With the engine warmed up, keep the engine speed at 1,500 to 2,000 r/min. (t-pm). If the CO concentration is 0.4% or less in this state, the catalytic converter is in good condition. If it exceeds the specification, refer to DIAGNOSIS (p. 5-15).

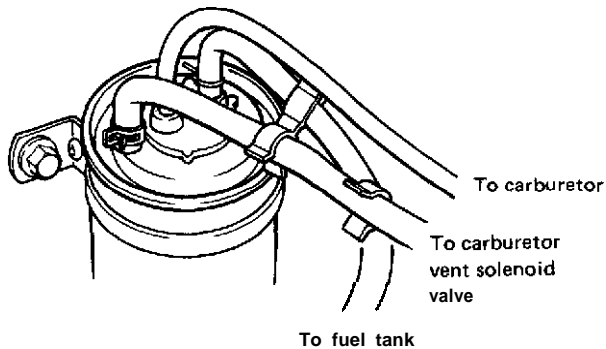
## 1. CHARCOAL CANISTER REPLACEMENT

### WARNING:

The following cautions should be always observed.

- Disconnect negative cable at battery.
- DO NOT smoke and place "NO SMOKING" signs near work area.
- Be sure to have CO<sub>2</sub> fire extinguisher handy.
- Wear safety glasses.
- To release the fuel vapor pressure in fuel tank, remove the fuel tank cap and then reinstall it.

- 1) Disconnect 3 hoses from canister.
- 2) Remove canister from car body.
- 3) Install new canister.
- 4) Connect 3 hoses to canister securely.
- 5) Clamp them securely.



## 12. EMISSION-RELATED HOSES AND TUBES INSPECTION

Check each vacuum hose and tube for secure connection. Also, check that it is free from any bend or damage.

Correct faulty condition, if any.

## 13. EXHAUST GAS RECIRCULATION (EGR) SYSTEM INSPECTION

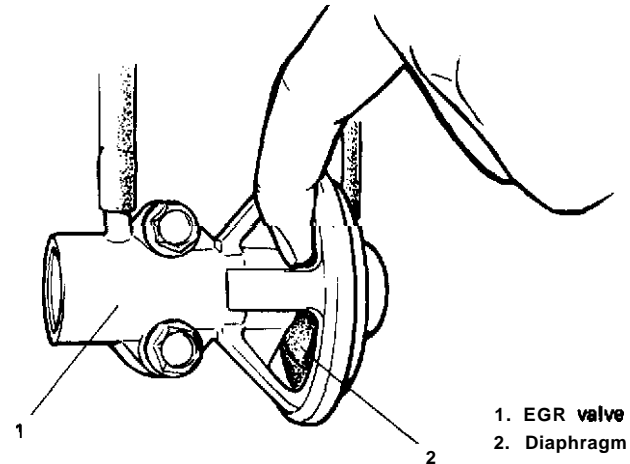
### NOTE:

- Before checking, confirm that altitude is not higher than 1,220 m (4,088 ft) (atmospheric pressure is below 680mmHg) and gear shift lever is at neutral position.
- When performing this check at higher than 1,220 m (4,000 ft) altitude, be sure to disconnect HAC coupler.

- 1) Run engine when it is cool (coolant temperature is below 55°C (131°F)) and check that EGR valve diaphragm is not operating in this state, by touching diaphragm with finger.

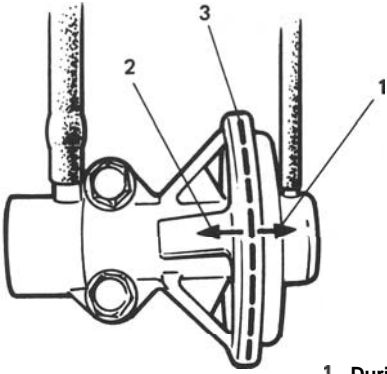
### WARNING:

If EGR valve is hot, it may be necessary to wear gloves to avoid burning finger.



Checking EGR valve diaphragm

- 2) Warm up engine to normal operating temperature and race it after warming up. Then check to be sure that diaphragm moves toward ① in below figure during acceleration and toward ② during deceleration.

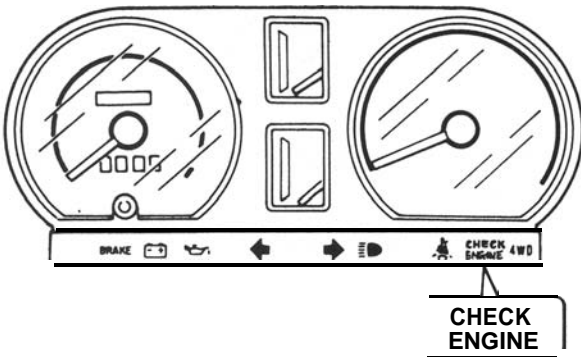


1. During acceleration
2. During deceleration
3. Diaphragm

*Movement of EGR valve diaphragm*

#### 14. ECM AND ASSOCIATED SENSORS INSPECTION

- 1) Start engine and warm it up to normal operating temperature.  
For Canadian specification vehicle, turn on check switch.
- 2) Run engine at 1500 – 2000 r/min (t-pm). In this state, make sure that “CHECK ENGINE” light flashes.  
Flashing of light proves that ECM and associated sensors are in good condition.  
If the light does not flash, check them and replace or adjust as necessary. Refer to SECTION 5 for checking procedure.



*“CHECK ENGINE” light*

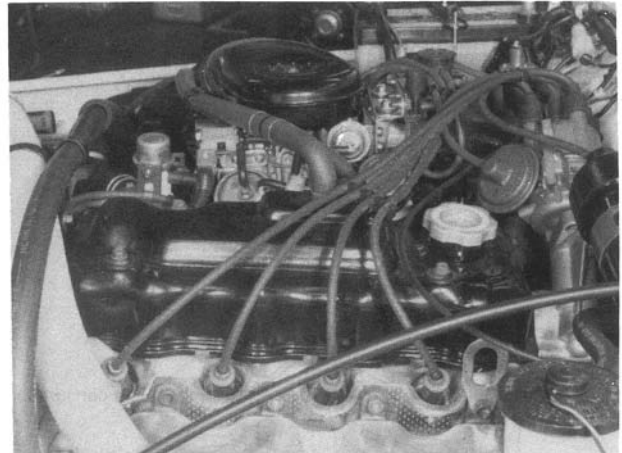
- 3) Turn off “CHECK ENGINE” light cancel or check switch on steering holder bracket.
- 4) Stop engine.

#### 15. WIRING HARNESS AND CONNECTIONS INSPECTION

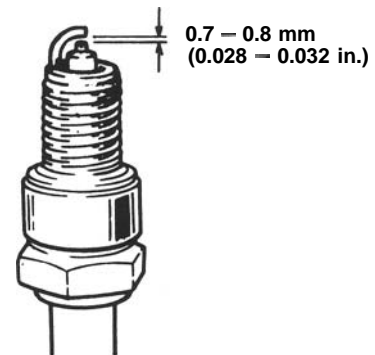
- 1) Visually inspect all wires located in engine compartment for evidence of breakage. Inspect the condition of the insulation (cracks). All clips and clamps should have solid connections to wires.
- 2) Replace any wires in a deteriorated or otherwise defective condition.

#### 16. SPARK PLUGS REPLACEMENT

- 1) Disconnect high-tension cords from spark plugs. Make sure to pull only on spark plug caps.



- 2) Using a spark plug wrench, loosen and remove plugs.



**NOTE:**

When replacing plugs, make sure to use new plugs of specified heat range and size.

**PLUG SPECIFICATION**

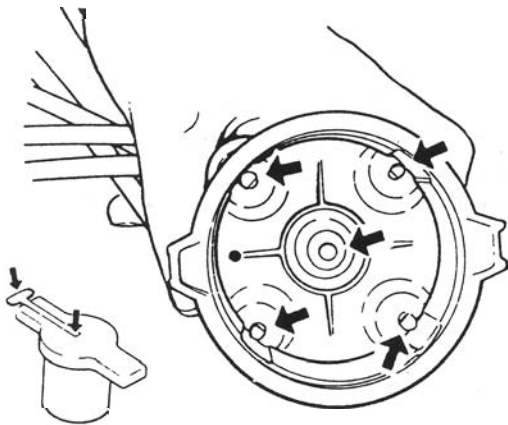
Maker	Heat range Standard type
NGK	BPR5ES
Nippon Denso	W16EXR-U

- 3) Install new spark plugs. Tighten plugs to specification.
- 4) Connect high tension cords to spark plugs. **DO NOT** push cords for connection. Push boots.

Spark plug tightening torque	20 – 30 N·m 2.0 – 3.0 kg·m 14.5 – 21.5 lb·ft
---------------------------------	--

**17. DISTRIBUTOR CAP AND ROTOR INSPECTION**

- 1) Inspect distributor cap and rubber caps for cracks.
- 2) Inspect center electrode and terminals for wear.



- 3) Inspect rotor for cracks, and its electrode for wear.
- 4) Check to see that there are no excessive closes in ventilation plug hole.
- 5) Repair or replace as necessary any component which is found to be in malcondition as described above.

**NOTE:**

Dust and stains found within distributor can be cleaned by using a dry, soft cloth.

**18. IGNITION WIRING REPLACEMENT**

- 1) Disconnect high tension cords from spark plugs, ignition coil and distributor.
- 2) Connect new high tension cords as shown and clamp them securely. **DO NOT** push cords for connection. Push boots.



**19. IGNITION TIMING INSPECTION**

Check to make sure that ignition timing is set properly. If out of specification, adjust it. Refer to p. 8-9 for inspection and adjustment procedure.

**20. DISTRIBUTOR ADVANCER INSPECTION**

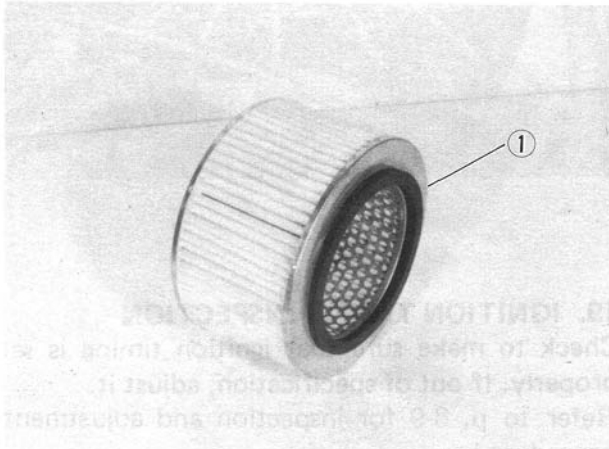
Check advancer for proper operation. Refer to p. 8-9 for checking procedure. Check vacuum hose for pinhole, crack or break. Correct or replace if necessary.

## 21. FUEL TANK CAP GASKET INSPECTION AND REPLACEMENT

Visually inspect gasket of fuel tank cap. If it is damaged or deteriorated, replace it with new one.

## 22. AIR CLEANER ELEMENT REPLACEMENT

- 1) Remove air cleaner cap.
- 2) Take cleaner element ① out of air cleaner case.
- 3) Install new cleaner element ① into cleaner case.



- 4) Install air cleaner cap securely.

## 23. THERMOSTATICALLY CONTROLLED AIR CLEANER SYSTEM INSPECTION

Check thermostatically controlled air cleaner system for proper operation. Refer to p. 5-19 for checking procedure.

## 24. CARBURETOR CHOKE SYSTEM LUBRICATION AND INSPECTION

- 1) Remove air intake case, and lubricate rotating parts.
- 2) Check choke for proper operation. Refer to p. 4-22 for checking procedure.

## 25. FUEL FILTER REPLACEMENT

### WARNING:

This work must be performed in a well ventilated area and away from any open flames (such as gas hot water heaters).

- 1) Disconnect negative cable from battery.
- 2) Remove fuel tank cap to release fuel vapor pressure in fuel tank. After releasing, reinstall the cap.
- 3) Disconnect inlet and outlet hoses from fuel filter located at the front part of fuel tank, inside the right-hand side of chassis.
- 4) Remove fuel filter with clamp.
- 5) Install new filter with clamp, and connect inlet and outlet hoses to fuel filter.

### NOTE:

The top connection is for the outlet hose, the lower one for the inlet hose.

- 6) Connect negative cable to battery.
- 7) After installation, start engine and check it for leaks.

## 26. FUEL LINES AND CONNECTIONS INSPECTION AND REPLACEMENT

### [INSPECTION]

Visually inspect fuel lines and connections for evidence of fuel leakage, hose cracking, and damage. Make sure all clamps are secure. Repair leaky joints, if any.

Replace hoses that are suspected of being cracked.

### [REPLACEMENT]

### WARNING:

The following cautions should be always observed.

- Disconnect negative cable at battery.
- DO NOT smoke and place "NO SMOKING" signs near work area.
- Be sure to have CO<sub>2</sub> fire extinguisher handy.
- Wear safety glasses.
- To release the fuel vapor pressure in fuel tank, remove the fuel tank cap and then reinstall it.

- 1) Replace fuel hoses (pipe to fuel pump, pipe to fuel filter and breather hose) in fuel feed and return lines with new ones.
- 2) Remove fuel tank.
- 3) Replace return hose (tank to return pipe) with new one.
- 4) Clamp hoses securely.
- 5) Install fuel tank referring to p. 4-35.
- 6) After installation, start engine and check it for leaks.

## 27. IDLE SPEED INSPECTION

### NOTE:

Before starting engine, place transmission gear shift lever in "Neutral", and set parking brake and block drive wheels.

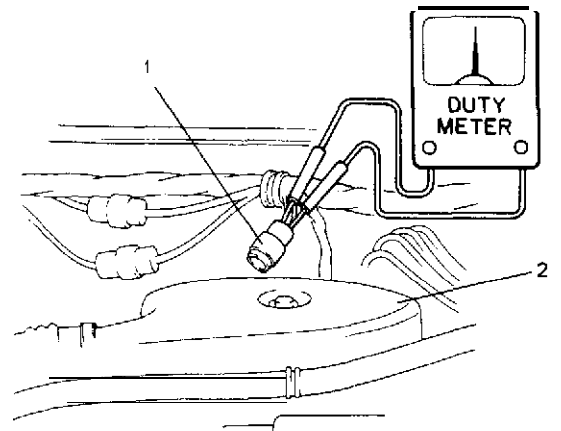
### WARNING:

Keep hands, tools, and clothing away from engine cooling fan to help prevent personal injury.

- 1) Warm up engine to normal operating temperature.
- 2) Check to ensure that idle speed is within 750 – 850 r/min (rpm).
- 3) If idle speed is not within specified range, adjust idle speed. Refer to MAINTENANCE SERVICE (p. 4-26) for procedures to check and adjust idle speed.

## 28. IDLE MIXTURE INSPECTION

- 1) Warm up engine to normal operating temperature.
- 2) Remove seal rubber of duty check coupler and connect positive terminal of duty meter to "Blue/Red" wire and negative terminal to "Black/Green" wire.



1. Duty check coupler  
2. Air intake case

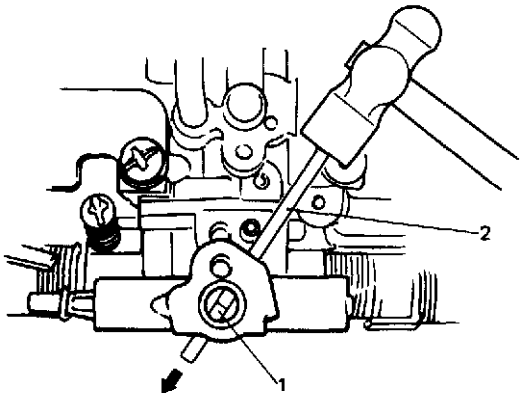
- 3) Set tachometer.
- 4) Run engine at 1,500 – 2,000 r/min for 30 seconds and bring it to idle speed.
- 5) Check duty at specified idle speed. If it is out of specification, adjust it to specification according to following adjustment procedure.

Specified Duty	10 - 50 at 750 – 850 r/min.
----------------	--------------------------------

After inspection, install seal rubber to duty check coupler.

Idle mixture adjustment procedure is as follows:

- 1) Remove carburetor from intake manifold following normal service procedure to gain access to mixture adjusting screw pin covering mixture adjusting screw.
- 2) Drive out mixture adjusting screw pin using about 4.5 mm (0.18 in) thick iron rod as shown below.



1. Mixture adjusting screw pin  
2. Rod

### **Mixture adjusting screw pin**

- 3) Reinstall carburetor following normal service procedures.  
Connect emission control system hoses and lead wires. Make specified play on accelerator cable and refill cooling system.
- 4) Place transaxle gear shift lever in "Neutral", set parking brake and block drive wheels.
- 5) Start engine, and warm it up to normal operating temperature, stop engine.
- 6) Be sure to check the following before idle mixture adjustment.
  - Fuel level is within round mark at the center of level gauge.
  - Valve lash is checked and adjusted according to the maintenance schedule.
  - Air cleaner has been properly installed and is in good condition.
  - All accessories (wipers, heater, lights etc) are out of service.
  - Ignition timing is within specification.
  - Choke valve opens fully.
  - Idle-up actuator does not operate.
- 7) Check and adjust idle speed to specification if necessary.
- 8) Remove seal rubber of duty check coupler and connect positive terminal of duty meter to "Blue/Red" wire and negative terminal to "Black/Green" wire.
- 9) Run engine at 1,500 – 2,000 r/min for 30 seconds and bring it to idle speed.

- 10) With engine running at idle speed, adjust idle mixture adjusting screw slowly in small increment allowing time for duty to stabilize after turning screw to obtain duty of 10 – 50. If duty is too low, back screw out; if too high, screw it in. After obtaining duty of 10 – 50, recheck idle speed, and adjust if necessary.

### **NOTE:**

**If adjustment can't be made because duty meter indicator does not deflect, check feed back system according to the checking procedure of system described in section of Emission Control System.**

- 11) After adjustment, install seal rubber to duty check coupler and drive in idle mixture adjusting screw pin.

## **29. CARBURETOR INSPECTION**

Check each carburetor mounting nut for tightness.

If it is found loose, tighten it securely.

Also, check where the carburetor and intake manifold are mated and other parts of the carburetor body for leakage. Be sure to correct the cause for leakage, if any.

### 1-3. CHASSIS AND BODY

#### 30. CLUTCH PEDAL INSPECTION

- 1) Check clutch pedal height. It should be the same as brake pedal height.
- 2) Check clutch pedal free travel.

Clutch pedal free travel	<b>20 – 30 mm (0.8 – 1.1 in.)</b>
--------------------------	---------------------------------------

For the details of the above steps 1) and 2), refer to MAINTENANCE SERVICE (p. 11-8) of SECTION 11.

#### 31. BRAKE DISCS, PADS, BRAKE DRUMS AND SHOES INSPECTION

##### Brake Discs and Pads

- 1) Remove wheel and caliper but don't disconnect brake hose from caliper.
- 2) Check front disc brake pads and discs for excessive wear, damage and deflection. Replace parts as necessary. For the details, refer to p. 19-1 6 and 19-1 7 of SECTION 19. Be sure to torque caliper guide pins to specification for reinstallation.

##### Brake Drums and Shoes

- 1) Remove wheel and brake drum.
- 2) Check rear brake drums and brake linings for excessive wear and damage, while wheels and drums are removed. Also check wheel cylinders for leaks, at the same time. Replace these parts as necessary.

For the details, refer to p. 19-21 and p. 19-22 of SECTION 19.

#### 32. BRAKE HOSES AND PIPES INSPECTION

Check brake hoses and pipes for proper hook-up, leaks, cracks, chafing and other damage. Replace any of these parts as necessary.

**CAUTION:**  
After replacing any brake pipe or hose, be sure to carry out air purge operation.

#### 33. BRAKE FLUID INSPECTION AND CHANGE

[INSPECTION]

- 1) **Check around** master cylinder and reservoir for fluid leakage.  
**If found leaky, correct.**
- 2) Check fluid level  
**If fluid level is lower than the minimum level of reservoir, refilling is necessary.** Fill reservoir with specified brake fluids.

Brake fluid	Specifications
	DOT 3

For the details, refer to MAINTENANCE SERVICE (p. 19-42) of SECTION 19.

##### **CAUTION:**

**Since the brake system of this car is factory-filled with glycol-base brake fluid, do not use or mix different type of fluid when refilling the system; otherwise serious damage will occur. Do not use old or used brake fluid, or one taken from unsealed container.**

[CHANGE]

- 1) Change brake fluid. As fluid change procedure, drain existing fluid from brake system completely, fill the system with above recommended fluid and carry out air purge operation.

For description of air purge, refer to p. 19-46 and 19-47 of SECTION 19.

#### 34. BRAKE PEDAL INSPECTION

**Check brake pedal travel.**

**For -checking procedure, refer to PEDAL TRAVEL CHECK (p. 19-43) of SECTION 19.**

#### 35. BRAKE LEVER AND CABLE INSPECTION

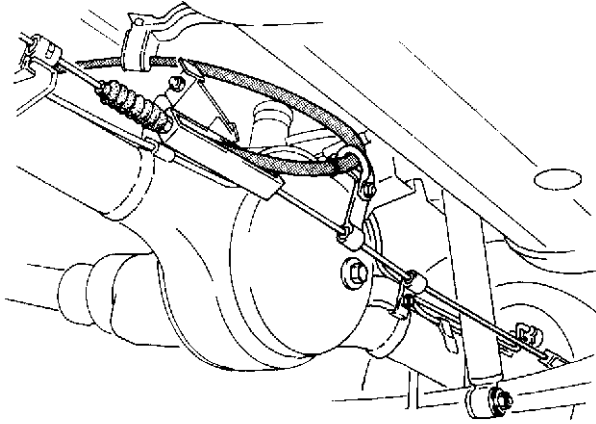
##### Parking Brake Lever

- 1) **Check tooth tip of each notch for damage or wear. If any damage or wear is found, replace parking lever.**
- 2) Check parking brake lever for proper operation and stroke, and adjust it if necessary. For checking and adjusting procedures, refer to PARKING BRAKE INSPECTION AND ADJUSTMENT (p. 19-44) of SECTION 19.



### Parking Brake Cable

Inspect brake cable for damage and smooth movement. Replace cable if it is in deteriorated condition.



### 36. TIRE INSPECTION AND ROTATION

- 1) Check tires for uneven or excessive wear, or damage. If defective, replace.
- 2) Check inflating pressure of each tire and adjust pressure to specification as necessary.

#### NOTE:

- Tire inflation pressure should be checked when tires are cool.
  - Specified tire inflation pressure should be found on tire placard or in owners' manual which came with the car.
- 3) Rotate tires.  
For the details of above steps 1) to 3), refer to MAINTENANCE SERVICE (p. 18-19 and 18-20) of SECTION 18.

### 37. WHEEL DISCS AND FREE WHEELING HUBS (if equipped) INSPECTION

#### Wheel Discs

Inspect each wheel disc for dents, distortion and cracks. A disc in badly damaged condition must be replaced.

#### Free Wheeling Hub

This is applicable to the car equipped with free wheeling hubs.

Check free wheeling hub for proper operation by moving free wheeling hub knob to LOCK and FREE positions. (The same check on both right and left wheels)

For checking procedure, refer to MAINTENANCE SERVICE (p. 17-29) of SECTION 17.

### 38. STEERING KNUCKLE OIL SEAL REPLACEMENT

For replacement procedure, refer to MAINTENANCE SERVICE (p. 17-23) of SECTION 17.

### 39. WHEEL BEARING INSPECTION

#### [Inspection of wheel bearing]

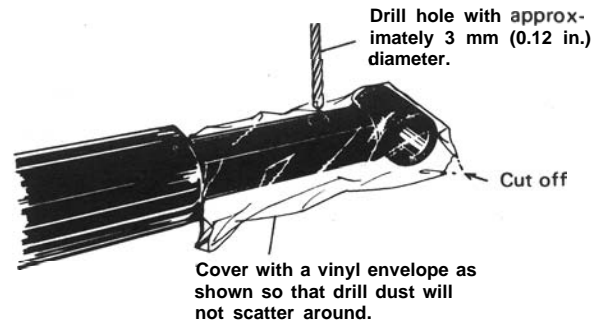
- 1) Check front wheel bearing for wear, damage, abnormal noise or rattles. For the details, refer to MAINTENANCE (p. 17-20 and 17-21) of SECTION 17.
- 2) Check rear wheel bearing for wear, damage abnormal noise or rattles. For the details, refer to MAINTENANCE SERVICE (p. 17-24) of SECTION 17.

#### [Inspection of front wheel bearing grease]

- 1) Remove wheel hub and spindle referring to FRONT WHEEL HUB REMOVAL of SECTION 17.
- 2) Check grease around front wheel bearing rollers and between front axle shaft surface and wheel spindle bush for deterioration and capacity.

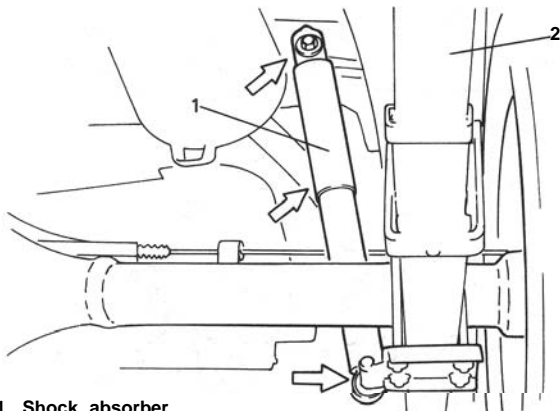
If grease is deteriorated, remove grease thoroughly and apply enough amount of new SUZUKI SUPER GREASE A or wheel bearing grease. If grease is found insufficient, add some more.

- 3) Install spindle, bearings, wheel hub, bearing nut and brake disc referring to INSTALLATION (p. 17-12) of SECTION 17.
  - 4) Adjust bearing preload and then tighten bearing lock nut to specification. Refer to MAINTENANCE (p. 17-21) of SECTION 17.
  - 5) Install drive flange or free wheeling hub (if equipped), brake caliper with mounting and wheel referring to INSTALLATION (p. 17-12) of SECTION 17.
- For tightening torque of each bolt and nut, refer to torque table (p. 17-26) of SECTION 17.



#### 40. SHOCK ABSORBERS INSPECTION

- 1) Inspect absorbers for evidence of oil leakage, dents or any other damage on sleeves; and inspect anchor ends for deterioration.
- 2) Depending on the results of the above inspection, replace absorbers.



1. Shock absorber  
2. Leaf spring

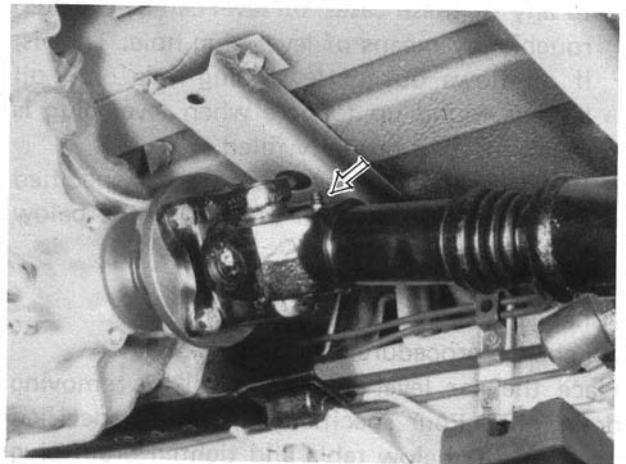
#### WARNING:

When handling rear shock absorber in which high-pressure gas is sealed, make sure to observe the following precautions.

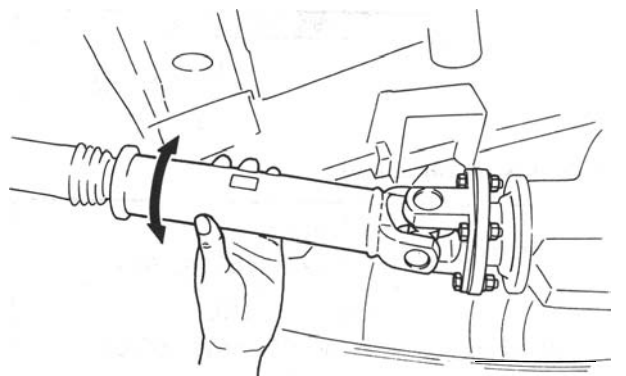
1. Don't disassemble it.
2. Don't put it into fire.
3. Don't store it where it gets hot
4. Before disposing it, be sure to drill a hole in it where shown in the illustration below and let gas and oil out. Lay it down sideways for this work.

#### 41. PROPELLER SHAFTS INSPECTION AND LUBRICATION

- 1) Lubricate propeller shaft,  
The nipple for lubrication is located on each sliding yoke. Be sure to use chassis grease.



- 2) Check universal joint and spline of propeller shaft for rattle. If rattle is found, replace defective part with a new one.



3) Check propeller shaft (No. 1, No. 2, No. 3) flange yoke bolts for tightness, and retighten them as necessary:

Tightening torque	N·m	kg·m	lb·ft
	23 – 30	2.3 – 3.0	17.0 – 21.5

#### 42. TRANSMISSION, TRANSFER, DIFFERENTIAL OIL INSPECTION AND CHANGE

[Inspection]

- 1) Inspect transmission case, transfer case and differential housing for evidence of oil leakage. Repair leaky point if any.
- 2) Make sure that the car is placed level for oil level check.
- 3) Remove each level plug of transmission, transfer and differential (front and rear). In any of these cases, oil level can be checked roughly by means of level plug hole. That is, if oil flows out of level plug hole or if oil level is found up to hole when level plug is removed, oil is properly filled.

If oil is found insufficient, pour specified amount of specified oil as given in the below table.

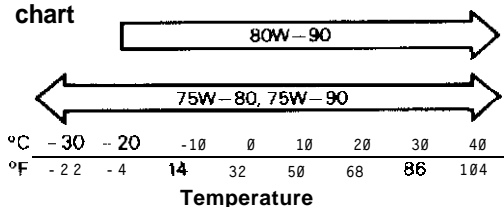
[Change]

Oil change procedure is as follows.

Place the car level and drain oil by removing drain plug. Pour specified amount of specified oil as in the below table and tighten drain plug and filler plug to specified torque.

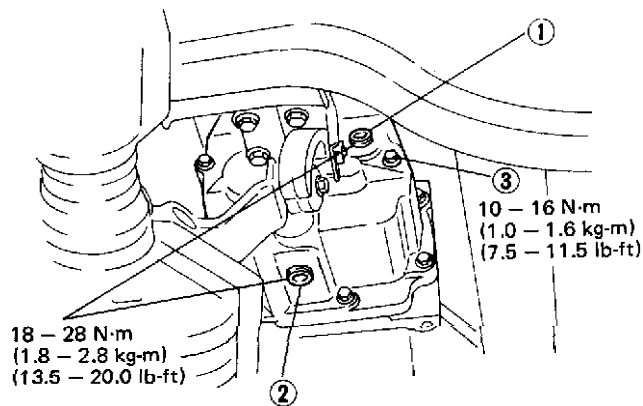
It is highly recommended to use SAE 75W-90 gear oil.

Viscosity chart  
SAE



Transmission oil change

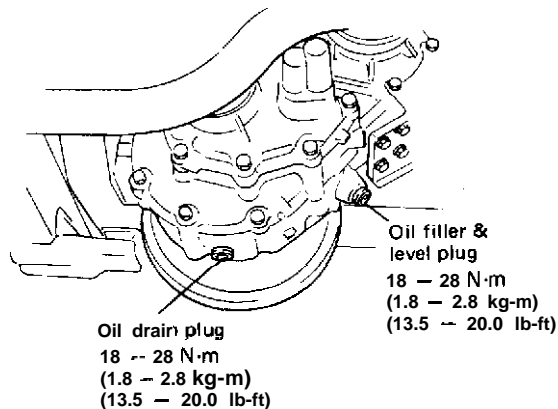
Oil capacity	1.3 liters (2.7/2.3 US/Imp pt.)
Type of oil	Gear oil, SAE 80W-90, 75W-80 or 75W-90



1. Oil filler plug
2. Oil drain plug
3. Oil level plug

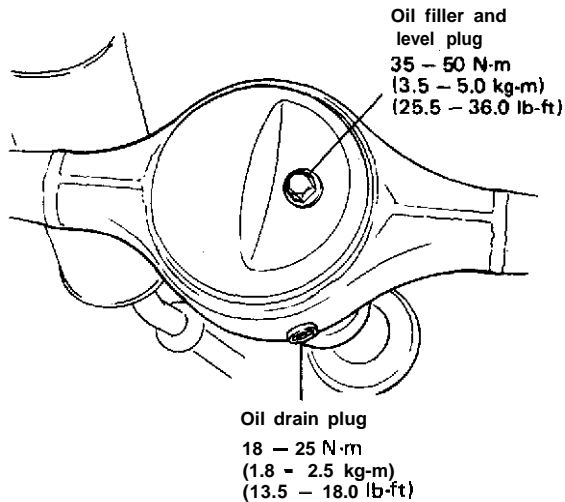
Transfer oil change

Oil capacity	0.8 liters (1.7/1.4 US/Imp. pt.)
Type of oil	Gear oil SAE 80W-90, 75W-80 or 75W-90



Differential oil change (Front and rear)

	Front	Rear
Oil capacity	2.0 liters (4.2/3.5 US/Imp pt.)	1.5 liters (3.2/2.6 US/Imp pt.)
Type of oil	Hypoid gear oil, SAE 80W-90, 75W-80 or 75W-90	



### 43. LEAF SPRING INSPECTION

Check leaf spring for wear, crack and damage. (Where each end of the shorter leaf contacts.) If excessive wear or cracking is noted, replace the spring with a new one.

### 44. BOLTS AND NUTS TIGHTENING

Check suspension bolts and nuts for tightness and retighten them as necessary. Repair or replace defective parts, if any.

#### NOTE:

For the details of check points, refer to the table of MAINTENANCE SERVICE (p. 17-24) of SECTION 17.

### 45. STEERING SYSTEM INSPECTION

1) Check steering wheel for play and rattle, holding car in straight forward condition on the ground.

Steering wheel play	10 – 30 mm (0.4 – 1.2 in.)
---------------------	-------------------------------

2) Check universal joint and rubber joint of steering shaft for rattle and damage. If rattle or damage is found, replace defective part with a new one.

3) Check bolts and nuts for tightness and retighten them as necessary. Repair or replace defective parts, if any. Refer to MAINTENANCE SERVICE on p. 18-18 for particular check points.

4) Inspect steering gear box for evidence of oil leakage. If leakage is found, check oil level in gear box.

#### NOTE:

For the details of the above steps 1) to 4), refer to MAINTENANCE SERVICE (p. 18-18) of SECTION 18.

5) Check boots of tie rod ends for damage. If damage is found, replace it with a new one.

6) Check wheel alignment.

#### Alignment service data

Side slip	OUT 0 – IN 3 m/km
Toe-in	2 - 6 m m (0.079 – 0.236 in.)
Camber	1 degree (1") ± 45'
Kingpin inclination	9 degrees (9") ± 2"
Caster	3 degrees 30 minutes (3" 30') ± 1°

#### NOTE:

For the details of wheel alignment, refer to WHEEL ALIGNMENT (p. 18-16) of SECTION 18.

### 46. DOOR HINGES LUBRICATION

Lubricate door hinges for smooth operation.

## **FINAL INSPECTION**

Carry out road test in safe place.

### **WARNING:**

**When carrying out the following road tests, select a safe place where no man or no running car is seen so as to prevent any accident.**

#### **1) Engine start**

Check engine start for readiness.

#### **2) Clutch**

Check the following:

- that clutch is completely released when depressing clutch pedal,
- that no slipping clutch occurs when releasing pedal and accelerating,
- and that clutch itself is free from any abnormal condition.

#### **3) Gearshift Lever (Transmission and Transfer)**

Check gearshift lever for smooth shifting to all positions and for good performance of transmission and transfer in any position.

#### **4) Brake**

[Foot brake]

Check the following when depressing brake pedal while driving;

- that brake works properly,
- that it is free from noise,
- and that braking force applies equally on all wheels.

[Parking brake]

Check to ensure that parking brake is fully effective when the car is stopped on the slope and brake lever is pulled all the way.

#### **5) Steering**

Check to ensure that steering wheel is free from instability, or abnormally heavy feeling while driving.

**SECTION 2**

**TROUBLE SHOOTING**

**CONTENTS**

<b>2-1. ENGINE .....</b>	<b>2-2</b>
<b>2-2. CARBURETOR .....</b>	<b>2-9</b>
<b>2-3. EXHAUST AND MUFFLER .....</b>	<b>2-9</b>
<b>2-4. CLUTCH .....</b>	<b>2-9</b>
<b>2-5. TRANSMISSION .....</b>	<b>2-10</b>
<b>2-6. DIFFERENTIALS .....</b>	<b>2-11</b>
<b>2-7. PROPELLER SHAFTS .....</b>	<b>2-12</b>
<b>2-6. BRAKES .....</b>	<b>2-12</b>
<b>2-9. SUSPENSION, STEERING SYSTEM AND TIRES .....</b>	<b>2-14</b>
<b>2-10. STARTING MOTOR.....</b>	<b>2-16</b>
<b>2-11. ALTERNATOR .....</b>	<b>2-17</b>
<b>2-12. WIPER MOTOR.....</b>	<b>2-18</b>
<b>2-13. FUEL METER .....</b>	<b>2-19</b>
<b>2-14. SPEEDOMETER .....</b>	<b>2-19</b>
<b>2-15. WATER TEMPERATURE METER .....</b>	<b>2-19</b>

## 2-1. ENGINE

Condition	Possible cause	Correction
<p>Poor starting (Hard starting)</p>	<p><b>Starter will not run</b></p> <ol style="list-style-type: none"> <li>1. Main fuse blown off</li> <li>2. Contact not closing in main switch, or this switch open-circuited</li> <li>3. Run-down battery</li> <li>4. Defective magnetic switch of starter</li> <li>5. Loose battery terminal connection</li> <li>6. Defective brushes in starter</li> <li>7. Loose battery cord connection</li> <li>8. Open in field or armature circuit of starter</li> </ol> <p><b>No sparking</b></p> <ol style="list-style-type: none"> <li>1. Defective spark plug</li> <li>2. High tension cord short-circuited (grounded)</li> <li>3. Cracked rotor or cap in distributor</li> <li>4. Defective signal generator or ignitor</li> <li>5. Maladjusted signal rotor air gap.</li> <li>6. Contact not closing positively in main switch, or this switch open-circuited</li> <li>7. Loose or blown fuse</li> <li>8. Improper ignition timing</li> <li>9. Defective ignition coil.</li> </ol> <p><b>Faulty intake and exhaust systems</b></p> <ol style="list-style-type: none"> <li>1. Carburetor out of adjustment</li> <li>2. Fuel pump not discharging adequately</li> <li>3. Clogged fuel filter</li> <li>4. Defective choke mechanism</li> <li>5. Loose intake manifold</li> <li>6. Dirty and clogged carburetor</li> <li>7. Float level out of adjustment</li> <li>8. Clogged fuel hose or pipe</li> <li>9. Not enough fuel in the tank</li> <li>10. Malfunctioning fuel cut solenoid valve</li> </ol> <p><b>Abnormal engine internal condition</b></p> <ol style="list-style-type: none"> <li>1. Ruptured cylinder head gasket</li> <li>2. Improper valve clearance</li> <li>3. Weakened or broken valve spring</li> <li>4. Loose manifold, permitting air to be drawn in</li> <li>5. Worn pistons, rings or cylinders</li> </ol>	<p>Replace Repair or replace</p> <p>Recharge Replace Clean and retighten Replace Retighten Repair or replace</p> <p>Adjust gap, or replace Repair or replace Replace Replace Adjust Replace</p> <p>Set right or replace Adjust Replace</p> <p>Adjust Replace Clean, or replace Repair or replace Retighten Disassemble and clean Adjust Clean or replace Refill Check solenoid valve for proper operation and replace if necessary</p> <p>Replace Adjust Replace Retighten and, as necessary, replace gasket Replace worn rings and pistons and rebore as necessary</p>

Condition	Possible cause	Correction
<p>Poor starting (Hard starting)</p>	<p>6. Broken valve timing belt 7. Poor valve seating 8. Wrong kind of engine oil 9. Burnt valves 10. Sticky valve stem</p> <p>Emission control 1. Malfunctioning PCV valve 2. Loose connection or disconnection of vacuum hoses 3. ECM is poorly grounded</p>	<p>Replace Repair or replace Replace Replace Correct or replace valve and guide</p> <p>Replace. Connect securely.</p> <p>Ground ECM securely</p>
<p>Not enough power</p>	<p>Inadequate compression 1. Improper valve clearance 2. Valves not seating tight 3. Valve stems tending to seize 4. Broken or weakened valve spring 5. Piston rings seized in grooves, or broken 6. Worn pistons, rings or cylinders</p> <p>7. Leaky cylinder head gasket</p> <p>Improperly timed ignition 1. Improper ignition timing 2. Defective spark plug 3. Worn distributor terminals 4. Leaks, loose connection or disconnection of high tension cord 5. Malfunctioning ignition timing advancers</p> <p>Fuel system out of order 1. Clogged carburetor jets 2. Defective fuel pump 3. Clogged fuel filter 4. Malfunctioning choke system 5. Float level out of adjustment 6. Clogged fuel pipe 7. Clogged fuel tank outlet 8. Loose joint in fuel system</p> <p>Abnormal condition in air intake system 1. Air cleaner dirty and clogged 2. Poor returning motion of choke valve</p> <p>Overheating tendency of engine 1. (Refer to the section entitled "overheating.")</p>	<p>Adjust Repair Replace Replace Replace Replace worn parts and rebore as necessary Replace</p> <p>Adjust Adjust gap or replace Dress or replace Connect or replace as necessary Replace</p> <p>Disassemble and clean Repair or replace Replace Adjust or replace Adjust Clean or replace Clean Retighten</p> <p>Clean or replace Repair, adjust or replace</p>



Condition	Possible cause	Correction
<p><b>Not enough power</b></p>	<p><b>Emission control</b></p> <ol style="list-style-type: none"> <li>1. Malfunctioning EGR valve</li> <li>2. Malfunctioning bowl vent solenoid valve.</li> <li>3. Malfunctioning high altitude switch.</li> <li>4. Malfunctioning throttle position switch (wide open switch)</li> </ol> <p><b>Others</b></p> <ol style="list-style-type: none"> <li>1. Dragging brakes</li> <li>2. Slipping clutch</li> </ol>	<p>Check and replace as necessary.  Check and replace as necessary.  Check and replace as necessary  Check nad replace as necessary</p> <p>Repair or replace  Adjust or replace</p>
<p><b>Engine hesitates (Momentary lack of response as the accelerator is depressed. Can occur at all car speeds. Usually most severe when first trying to make the car move, as from a stop sign.)</b></p>	<p><b>Abnormal condition in electrical systems</b></p> <ol style="list-style-type: none"> <li>1. Defective spark plug or plug gap out of adjustment</li> <li>2. Cracked rotor or cap in distributor, resulting in leakage</li> <li>3. Deteriorated ignition coil, or crack resulting in leakage</li> <li>4. Leaky high-tension cords</li> <li>5. Ignition timing out of adjustment</li> </ol> <p><b>Abnormal condition in fuel system</b></p> <ol style="list-style-type: none"> <li>1. Improper adjustment of float level</li> <li>2. Clogged carburetor jets</li> <li>3. Malfunctioning accelerator pump</li> <li>4. Inadequately discharging fuel pump</li> </ol> <p><b>Abnormal condition in engine</b></p> <ol style="list-style-type: none"> <li>1. Loss of compression pressure due to leaky cylinder head gasket</li> <li>2. Compression pressure too low because of worn pistons, rings, cylinders or burnt valves</li> </ol> <p><b>Emission control</b></p> <ol style="list-style-type: none"> <li>1. Malfunctioning bowl vent solenoid valve</li> <li>2. Malfunctioning throttle position switch (wide open switch)</li> <li>3. Malfunctionnig high altitude switch</li> <li>4. Malfunctioning EGR valve</li> <li>5. Malfunctioning thermostatically controlled air cleaner</li> </ol>	<p>Replace or adjust gap</p> <p>Replace</p> <p>Replace</p> <p>Replace  Adjust as prescribed</p> <p>Adjust  Clean  Check and replace as necessary  Replace</p> <p>Replace</p> <p>Replace and rebore as necessary</p> <p>Check and replace as necessary  Check and replace as necessary  Check and replace as necessary  Check and replace as necessary  Check and replace as necessary</p>

Condition	Possible cause	Correction
<p><b>Surges</b> (Engine power variation under steady throttle or cruise. Feels like the car speeds up and down with no change in the accelerator pedal.)</p>	<p><b>Fuel system out of order</b></p> <ol style="list-style-type: none"> <li>1. Clogged fuel filter</li> <li>2. Kinky, leaky or damaged fuel hoses and lines</li> <li>3. Malfunctioning fuel pump</li> <li>4. Leaky manifold and carburetor gaskets</li> <li>5. Improper float level</li> </ol> <p><b>Ignition system out of order</b></p> <ol style="list-style-type: none"> <li>1. Improper ignition timing</li> <li>2. Malfunctioning ignition timing advancers (mechanical and vacuum)</li> <li>3. Leaky or loosely connected high tension cord</li> <li>4. Defective spark plug (excess carbon deposits, improper gap, burned electrodes, etc..)</li> <li>5. Cracked rotor or cap in distributor</li> </ol> <p><b>Emission control</b></p> <ol style="list-style-type: none"> <li>1. Malfunctioning bowl vent solenoid valve</li> <li>2. Malfunctioning throttle position switch (wide open switch)</li> <li>3. Malfunctioning high altitude switch</li> <li>4. Malfunctioning EGR valve</li> <li>5. Malfunctioning thermostatically controlled air cleaner</li> </ol>	<p>Replace Check and replace as necessary Check and replace as necessary Replace Adjust</p> <p>Adjust Check or replace</p> <p>Check and repair or replace Check and clean, adjust or replace Replace</p> <p>Check and replace as necessary Check and replace as necessary Check and replace as necessary Check and replace as necessary Check and replace as necessary.</p>
<p><b>Dieseling</b> (Engine continues to run after ignition switch is turned off. it runs unevenly and may make knocking noise. )</p>	<p><b>Malfunctioning fuel cut solenoid valve in carburetor</b></p>	<p>Check solenoid valve for proper operation and replace as necessary</p>
<p><b>Erratic idling</b> (Improper engine idling)</p>	<p><b>Abnormal condition in ignition system</b></p> <ol style="list-style-type: none"> <li>1. Defective spark plug</li> <li>2. Leaky or disconnected high tension cord</li> <li>3. Worn distributor terminals</li> <li>4. Improper ignition timing</li> <li>5. Cracked cap in distributor, leakage inside</li> </ol>	<p>Adjust or replace Connect or replace Replace Adjust Replace</p>

Condition	Possible cause	Correction
<b>Erratic idling (Improper engine idling)</b>	<p><b>Abnormal condition in fuel system</b></p> <ol style="list-style-type: none"> <li>1. Clogged carburetor jets</li> <li>2. Incorrect idle adjustment</li> <li>3. Clogged air cleaner element</li> <li>4. Leaky manifold, carburetor or cylinder head gaskets</li> <li>5. Improper float level</li> <li>6. Malfunctioning choke system</li> <li>7. Malfunctioning fuel cut solenoid valve</li> </ol> <p><b>Others</b></p> <ol style="list-style-type: none"> <li>1. Loose connection or disconnection. of vacuum hoses</li> <li>2. Malfunctioning PCV valve</li> <li>3. Low compression</li> <li>4. Loose carburetor and intake manifold bolts and nuts</li> <li>5. Leaky carburetor and intake manifold gaskets</li> </ol>	<p>Clean Adjust Clean or replace Replace</p> <p>Adjust Adjust or replace Replace</p> <p>Connect</p> <p>Check and replace as necessary Previously outlined Tighten bolts and nuts</p> <p>Replace</p>
<b>Abnormal detonation</b>	<p><b>Abnormal condition in ignition system</b></p> <ol style="list-style-type: none"> <li>1. Spark plugs tending to overheat</li> <li>2. Improper ignition timing</li> <li>3. Loose connection in high-tension or low-tension circuit.</li> </ol> <p><b>Abnormal condition in fuel system</b></p> <ol style="list-style-type: none"> <li>1. Clogged fuel filter and fuel lines</li> <li>2. Clogged carburetor jets</li> <li>3. Improper adjustment of float level</li> <li>4. Malfunctioning fuel pump</li> <li>5. Air inhaling from intake manifold and carburetor gaskets</li> </ol> <p><b>Abnormal condition in engine</b></p> <ol style="list-style-type: none"> <li>1. Excessive carbon deposit on piston crowns or cylinder head</li> <li>2. Blown cylinder head gasket, resulting in low compression pressure</li> <li>3. Improper valve clearance</li> <li>4. Valves tending to seize</li> <li>5. Weakened valve springs</li> </ol> <p><b>Others</b></p> <p>Malfunctioning EGR valve</p>	<p>Change plug heat value Adjust Retighten</p> <p>Replace or clean Clean Adjust Replace Replace</p> <p>Clean</p> <p>Replace</p> <p>Adjust Replace Replace</p> <p>Replace</p>

Condition	Possible cause	Correction
<p><b>Overheating</b></p>	<p><b>Abnormal condition in ignition system</b></p> <ol style="list-style-type: none"> <li>1. Improper ignition timing</li> <li>2. Wrong heat value of spark plugs</li> </ol> <p><b>Abnormal condition in fuel systems</b></p> <ol style="list-style-type: none"> <li>1. Float level set too low</li> <li>2. Clogged jets in carburetor</li> <li>3. Loose inlet manifold</li> </ol> <p><b>Abnormal condition in cooling system</b></p> <ol style="list-style-type: none"> <li>1. Not enough coolant</li> <li>2. Loose or broken fan belt</li> <li>3. Erratically working thermostat</li> <li>4. Poor water pump performance</li> <li>5. Leaky radiator cores</li> </ol> <p><b>Abnormal condition in lubrication system</b></p> <ol style="list-style-type: none"> <li>1. Clogged oil filter</li> <li>2. Clogged oil strainer</li> <li>3. Deteriorated oil pump performance</li> <li>4. Oil leakage from oil pan or pump</li> <li>5. Improper engine oil grade</li> </ol> <p>6. Not enough oil in oil pan</p> <p><b>Others</b></p> <ol style="list-style-type: none"> <li>1. Dragging brakes</li> <li>2. Slipping clutch</li> <li>3. Blown cylinder head gasket</li> </ol>	<p><b>Adjust</b> <b>Change heat value</b></p> <p><b>Adjust</b> <b>Clean</b> <b>Retighten</b></p> <p><b>Refill</b> <b>Adjust or replace</b> <b>Replace</b> <b>Replace</b> <b>Repair or replace</b></p> <p><b>Replace</b> <b>Clean</b> <b>Replace</b> <b>Repair</b> <b>Replace with proper grade oil</b> <b>Replenish</b></p> <p><b>Repair or replace</b> <b>Adjust or replace</b> <b>Replace</b></p>
<p><b>Engine noise</b> <b>Note: Before checking the mechanical noise, make sure that:</b></p> <ul style="list-style-type: none"> <li>• Ignition timing is properly adjusted.</li> <li>• Specified spark plug is used.</li> <li>• Specified fuel is used.</li> </ul>	<p><b>Crankshaft noise</b></p> <ol style="list-style-type: none"> <li>1. Worn-down bearings, resulting in excessively large running clearances</li> <li>2. Worn connecting-rod bearings</li> <li>3. Distorted connecting rods</li> <li>4. Worn crankshaft journals</li> <li>5. Worn crankpins.</li> </ol> <p><b>Noise due to pistons, rings, pins or cylinders</b></p> <ol style="list-style-type: none"> <li>1. Abnormally worn cylinder bores</li> <li>2. Worn pistons, rings or pins</li> <li>3. Pistons tending to seize</li> <li>4. Broken piston rings</li> </ol> <p><b>Others</b></p> <ol style="list-style-type: none"> <li>1. Excessively large camshaft thrust play</li> <li>2. Excessively large crankshaft thrust clearance</li> <li>3. Valve clearance too large</li> <li>4. Not enough engine oil</li> </ol>	<p><b>Replace</b></p> <p><b>Replace</b> <b>Repair or replace</b> <b>Repair by grinding, or replace crankshaft</b> <b>Repair by grinding, or replace crankshaft</b></p> <p><b>Rebore to next oversize or replace</b> <b>Replace</b> <b>Replace</b> <b>Replace</b></p> <p><b>Replace</b> <b>Adjust as prescribed</b> <b>Adjust as prescribed</b> <b>Replenish</b></p>

Condition	Possible cause	Correction
<p><b>High fuel consumption</b></p>	<p><b>Abnormal condition ignition system</b></p> <ol style="list-style-type: none"> <li>1. Improper ignition timing</li> <li>2. Leak or loose connection of high tension cord</li> <li>3. Defective spark plug (improper gap, heavy deposits, and burned electrodes, etc..)</li> <li>4. Cracked distributor cap or rotor</li> <li>5. Malfunctioning mechanical and vacuum advancers in distributor</li> </ol> <p><b>Abnormal condition in fuel system</b></p> <ol style="list-style-type: none"> <li>1. Improper float level</li> <li>2. Fuel leakage from tank, pipe or carburetor</li> <li>3. Malfunctioning carburetor choke system</li> <li>4. Dirty or clogged carburetor jets</li> <li>5. Clogged air cleaner element</li> <li>6. Malfunctioning thermostatically controlled air cleaner</li> </ol> <p><b>Abnormal condition in engine</b></p> <ol style="list-style-type: none"> <li>1. Low compression</li> <li>2. Poor valve seating</li> <li>3. Improper valve clearance</li> </ol> <p><b>Emission control</b></p> <ol style="list-style-type: none"> <li>1. Air leaks at exhaust manifold</li> <li>2. Oxygen sensor out of order</li> <li>3. Water temperature switch out of order</li> <li>4. Malfunctioning throttle position switch</li> <li>5. Malfunctioning MCS (mixture control solenoid) valve in carburetor</li> <li>6. Malfunctioning EGR valve</li> </ol> <p><b>Others</b></p> <ol style="list-style-type: none"> <li>1. Dragging brakes</li> <li>2. Slipping clutch</li> <li>3. Improper tire pressure</li> </ol>	<p><b>Adjust</b>  <b>Repair or replace</b>  <b>Clean, adjust or replace</b></p> <p><b>Replace</b>  <b>Check and repair or replace</b></p> <p><b>Adjust</b>  <b>Repair or replace</b>  <b>Repair or replace</b>  <b>Clean</b>  <b>Clean or replace</b>  <b>Check and repair or replace</b></p> <p><b>Previously outlined</b>  <b>Repair or replace</b>  <b>Adjust</b></p> <p><b>Tighten manifold bolts and nuts.</b>  <b>Replace gasket.</b>  <b>Replace.</b>  <b>Replace.</b>  <b>Replace</b>  <b>Replace</b></p> <p><b>Replace</b></p> <p><b>Repair or replace</b>  <b>Adjust or replace</b>  <b>Adjust</b></p>
<p><b>Excessive engine oil consumption</b></p>	<p><b>Oil leakage</b></p> <ol style="list-style-type: none"> <li>1. Loose oil drain plug</li> <li>2. Loose oil pan securing bolts</li> <li>3. Deteriorated or broken oil pan sealant</li> <li>4. Leaky oil seals</li> <li>5. Blown cylinder head gasket</li> <li>6. Improper tightening of oil filter</li> <li>7. Loose oil pressure switch</li> </ol>	<p><b>Tighten</b>  <b>Tighten</b>  <b>Replace sealant</b>  <b>Replace</b>  <b>Replace</b>  <b>Tighten</b>  <b>Tighten</b></p>

Condition	Possible cause	Correction
Excessive engine oil consumption	<b>“Oil pumping” (Oil finding its way into combustion chambers.)</b> 1. Sticky piston ring  2. Worn piston ring groove and ring 3. Worn pistons or cylinders	Remove carbon and replace rings Replace piston and ring Replace pistons and rebore as necessary
	<b>Oil leakage along valve stems</b> 1. Defective valve stem oil seals 2. Badly worn valve stem	Replace Replace

## 2-2. CARBURETOR

Condition	Possible cause	Correction
Fuel overflow from carburetor	1. Float valve worn or dirty with foreign matter 2. Float level set too high 3. Float ruptured and containing some fuel 4. Broken or otherwise defective gasket 5. Loose float chamber securing screws	Clean or replace Adjust as prescribed Replace Replace Retighten

## 2-3. EXHAUST AND MUFFLER

Condition	Possible cause	Correction
Poor muffling performance	1. Loose exhaust pipe connection 2. Broken muffler gasket 3. Broken manifold, pipe or muffler 4. Exhaust manifold loose in place 5. Interference between body and muffler	Retighten Replace Repair or replace Retighten Repair, eliminating any contact

## 2-4. CLUTCH

Condition	Possible cause	Correction
Slipping clutch	1. Loss of clearance at the tip of release fork 2. Clutch facings dirty with oil 3. Clutch facings excessively worn 4. Weakened diaphragm spring 5. Distorted pressure plate or flywheel surface 6. Improper clutch pedal free travel	Adjust as prescribed Replace Replace Replace Replace Adjust and, as necessary, replace clutch facings

Condition	Possible cause	Correction
<b>Dragging clutch</b>	<ol style="list-style-type: none"> <li>1. Improper clutch pedal free travel</li> <li>2. Weakened diaphragm spring, or worn spring tip</li> <li>3. Damaged or worn splines of transmission input shaft</li> <li>4. Front input shaft bearing worn or broken</li> <li>5. Excessively wobbly clutch disc</li> <li>6. Clutch facings broken or dirty with oil</li> </ol>	Adjust free travel Replace  Replace  Replace Replace Replace
<b>Clutch vibration</b>	<ol style="list-style-type: none"> <li>1. Glazed (glass-like) clutch facings</li> <li>2. Clutch facings dirty with oil</li> <li>3. Wobbly clutch disc, or poor facing contact</li> <li>4. Weakened torsion springs (in clutchdisc)</li> <li>5. Clutch disc rivets loose</li> <li>6. Distorted pressure plate or flywheel surface</li> <li>7. Weakened engine mounting or loosened mounting bolt or nut</li> </ol>	Repair or replace Replace Replace Replace Replace the disc Replace Retighten or replace
<b>Noisy clutch</b>	<ol style="list-style-type: none"> <li>1. Worn or broken release bearing</li> <li>2. Front input shaft bearing worn down</li> <li>3. Excessive rattle of clutch disc hub</li> <li>4. Cracked clutch disc</li> <li>5. Pressure plate and diaphragm spring rattling</li> </ol>	Replace Replace Replace the disc Replace Replace
<b>Grabbing clutch</b>	<ol style="list-style-type: none"> <li>1. Clutch facings soaked with oil</li> <li>2. Excessively worn clutch facings</li> <li>3. Rivet heads showing out of the facing</li> <li>4. Weakened torsion springs</li> </ol>	Replace Replace Replace Replace

## 2-5. TRANSMISSION

Condition	Possible cause	Correction
<b>Gears slipping out of mesh</b>	<ol style="list-style-type: none"> <li>1. Worn shift fork shaft</li> <li>2. Worn locating steel balls</li> <li>3. Weakened springs for locating steel balls</li> <li>4. Worn shift fork</li> <li>5. Excessive rattle in thrust direction of gears</li> <li>6. Worn ring or hub in synchronizers</li> <li>7. Worn bearings of input shaft, main shaft or countershaft</li> </ol>	Replace Replace Replace Replace Replace Replace Replace
<b>Gears refusing to dis-engage</b>	<ol style="list-style-type: none"> <li>1. Weakened or broken synchronizer springs</li> <li>2. Worn inner groove of synchronizer ring</li> <li>3. Synchronizer ring seized on. the cone</li> <li>4. Distorted shift fork shaft or shift fork</li> </ol>	Replace Replace Replace the ring Replace.

Condition	Possible cause	Correction
Excessive gear noise	<ol style="list-style-type: none"> <li>1. Not enough oil in transmission</li> <li>2. Defective synchronizer</li> <li>3. Gears rattling in thrust direction</li> <li>4. Broken or worn bearings</li> <li>5. Damaged or worn gears</li> </ol>	Replenish Replace Replace Replace Replace
Hard shifting	<ol style="list-style-type: none"> <li>1. Clutch pedal play too large, resulting in a “dragging clutch”</li> <li>2. Worn clutch disc facings</li> <li>3. Clutch disc facings dirty with oil.</li> <li>4. Distorted or unevenly worn shift fork shaft</li> <li>5. Broken locating balls</li> <li>6. Worn synchronizer sleeve or ring</li> <li>7. Worn synchronizer hub</li> </ol>	Adjust as prescribed  Replace. Replace. Replace Replace Replace Replace

## 2-6. DIFFERENTIALS

C o n d i t i o n	Possible cause	Correction
Gear noise	<ol style="list-style-type: none"> <li>1. Maladjusted backlash between drive pinion and ring gear</li> <li>2. Damaged gear teeth or improper mesh of drive pinion and ring gear</li> <li>3. Improper tooth contact in the mesh between drive pinion and ring gear</li> <li>4. Insufficient or wrong kind of gear oil</li> <li>5. Ring gear wobbling when turning, or ring gear securing bolts loose</li> <li>6. Broken or otherwise damaged teeth of side gears or differential pinion gears</li> </ol>	Adjust as prescribed  Replace or adjust  Adjust as prescribed  Replenish or replace Replace, or retighten  Replace
Bearing noise	<ol style="list-style-type: none"> <li>1. (Constant noise) Insufficient or wrong kind of gear oil</li> <li>2. (Constant noise) Damaged or worn bearings or borne parts</li> <li>3. (Noise during coasting) Damaged bearings of rear drive pinion</li> <li>4. (Noise during turning) Broken bearings on axle shafts</li> </ol>	Replenish or change  Replace.  Replace  Replace



## 2-7. PROPELLER SHAFTS

Condition	Possible cause	Correction
Vibration and noise	<ol style="list-style-type: none"> <li>1. Broken or worn bearings of universal joint spider</li> <li>2. Distorted propeller shaft</li> <li>3. Unbalanced propeller shaft</li> <li>4. Loose propeller shaft</li> </ol>	<p>Replace</p> <p>Replace</p> <p>Replace</p> <p>Retighten</p>
Noise occurring at standing start or during coasting	<ol style="list-style-type: none"> <li>1. Worn or damaged universal joint</li> <li>2. Worn propeller shaft splines, due to lack of lubrication</li> <li>3. Loose propeller shaft</li> <li>4. Loose flanged yoke of universal joint</li> </ol>	<p>Replace</p> <p>Replace</p> <p>Retighten</p> <p>Retighten</p>

## 2-8. BRAKES

Condition	Possible cause	Correction
Not enough braking force	<ol style="list-style-type: none"> <li>1. Brake oil leakage from brake lines</li> <li>2. Brake disc or pads stained with oil</li> <li>3. Overheated brakes</li> <li>4. Poor contact of shoes on brake drum</li> <li>5. Brake shoes linings stained with oil or wet with water</li> <li>6. Badly worn brake shoe linings</li> <li>7. Defective wheel cylinders</li> <li>8. Malfunctioning caliper assembly</li> </ol>	<p>Locate leak point and repair</p> <p>Clean or replace</p> <p>Determine cause and repair</p> <p>Repair for proper contact</p> <p>Replace</p> <p>Replace</p> <p>Repair or replace</p> <p>Repair or replace</p>
Brake Pull (Brakes not working in unison)	<ol style="list-style-type: none"> <li>1. Shoe linings wet with water or stained with oil in some brakes</li> <li>2. Drum-to-shoe clearance out of adjustment in some brakes (Malfunctioning auto adjusting mechanism)</li> <li>3. Drum out of round in some brakes</li> <li>4. Wheel tires inflated unequally</li> <li>5. Malfunctioning wheel cylinders</li> <li>6. Disturbed front end alignment</li> <li>7. Unmatched tires on same axle</li> <li>8. Restricted brake tubes or hoses</li> <li>9. Malfunctioning caliper assembly</li> <li>10. Loose suspension parts</li> <li>11. Loose calipers</li> </ol>	<p>Replace</p> <p>Check for inoperative auto adjusting mechanism</p> <p>Replace</p> <p>Inflate equally</p> <p>Repair or replace</p> <p>Adjust as prescribed</p> <p>Use tires with approximately the same amount of tread on the same axle</p> <p>Check for soft hoses and damaged lines. Replace with new hoses and new double-walled steel brake tubing.</p> <p>Check for stuck or sluggish pistons and proper lubrication of caliper slide bus</p> <p>Caliper should slide.</p> <p>Check all suspension mountings</p> <p>Check and torque bolts to specifications</p>

Condition	Possible cause	Correction
Excessive pedal travel (Pedal stroke too large)	<ol style="list-style-type: none"> <li>1. Partial brake system failure</li> <li>2. Insufficient fluid in master cylinder reservoirs</li> <li>3. Air in system (Pedal soft/spongy)</li> <li>4. Rear brake system not adjusted (malfunctioning auto adjusting mechanism)</li> <li>5. Bent brake shoes</li> <li>6. Worn rear brake shoes</li> </ol>	<p>Check diagonal brake systems and repair as necessary</p> <p>Fill reservoirs with approved brake fluid. Check for leaks and air in brake systems. Check warning light. Bleed system if necessary.</p> <p>Bleed system</p> <p>Adjust rear brakes (Repair auto adjusting mechanism)</p> <p>Replace brake shoes</p> <p>Replace brake shoes</p>
Dragging brakes (A very light drag is present in all disc brakes immediately after pedal is released)	<ol style="list-style-type: none"> <li>1. Master cylinder pistons not returning correctly</li> <li>2. Clogged return port in master cylinder</li> <li>3. Restricted brake tubes or hoses</li> <li>4. Incorrect parking brake adjustment</li> <li>5. Weakened or broken return springs in the brake</li> <li>6. Sluggish parking-brake cables or linkage</li> <li>7. Wheel cylinder or caliper piston sticking</li> </ol>	<p>Repair master cylinder</p> <p>Clean</p> <p>Check for soft hoses or damaged tubes and replace with new hoses and/or new double-walled steel brake tubing</p> <p>Check and adjust to correct specifications</p> <p>Replace</p> <p>Repair or replace</p> <p>Repair as necessary</p>
Pedal pulsation (Pedal pulsates when depressed for braking)	<ol style="list-style-type: none"> <li>1. Damaged or loose wheel bearings</li> <li>2. Excessive disc lateral runout</li> <li>3. Parallelism not within specifications</li> <li>4. Rear drums out of round</li> </ol>	<p>Replace wheel bearings</p> <p>Check per instructions. If not within specifications, replace or machine the disc.</p> <p>Check per instructions. If not within specifications, replace or machine the disc.</p> <p>Check runout.</p>
Braking noise	<ol style="list-style-type: none"> <li>1. Glazed shoe linings, or foreign matters stuck to linings</li> <li>2. Worn or distorted shoe linings</li> <li>3. Loose front wheel bearings</li> <li>4. Distorted backing plates or loose mounting bolts</li> </ol>	<p>Repair or replace shoe lining</p> <p>Replace shoe lining (or pad)</p> <p>Replace wheel bearings</p> <p>Replace or retighten securing bolts</p>

## 2-9. SUSPENSION, STEERING SYSTEM AND TIRES

Condition	Possible cause	Correction
<b>Hard steering</b>	<ol style="list-style-type: none"> <li>1. Wheel tires not adequately inflated</li> <li>2. Bind in tie rod end ball stud</li> <li>3. Linkage connections tending to seize</li> <li>4. Steering gearbox out of adjustment</li> <li>5. Unevenly worn steering shaft bush</li> <li>6. Disturbed front wheel alignment</li> </ol>	<p>Adjust the pressure            Replace            Repair or replace            Adjust as prescribed            Replace            Adjust as prescribed</p>
<b>Wobbly steering wheel (Shimmy, shake or vibration)</b>	<ol style="list-style-type: none"> <li>1. Wheel tires inflated unequally</li> <li>2. Wobbly wheels</li> <li>3. Large difference in tire diameter between right and left wheels</li> <li>4. Loose hub nuts</li> <li>5. Damaged or worn wheel bearings</li> <li>6. Worn or loose tie rod ends</li> <li>7. Steering gearbox out of adjustment</li> <li>8. Steering gearbox mounted loose</li> <li>9. Worn steering knuckle oil seal</li> <li>10. Tire or wheel out of balance</li> <li>11. Blister or bump on tire</li> <li>12. Disturbed front wheel alignment</li> </ol>	<p>Adjust tire pressure            Repair or replace            Replace</p> <p>Retighten            Replace            Replace or retighten            Adjust as prescribed            Retighten            Replace            Balance wheel or replace tire and/or wheel            Replace tire            Check front wheel alignment</p>
<b>Steering wheel pulling to one side (car pulls)</b>	<ol style="list-style-type: none"> <li>1. Unevenly worn wheel tires</li> <li>2. Brake dragging in one road wheel</li> <li>3. Wheel tires unequally inflated</li> <li>4. Worn or distorted link rods</li> <li>5. Disturbed front wheel alignment</li> <li>6. Loose, bent or broken front or rear suspension parts</li> </ol>	<p>Replace            Repair            Adjust tire pressure            Replace            Adjust as prescribed            Tighten or replace suspension parts</p>
<b>Shocks coming to steering wheel (or wheel tramp)</b>	<ol style="list-style-type: none"> <li>1. Tire inflating pressure too high</li> <li>2. Poor shock absorber performance</li> <li>3. Differences in tire diameter among four road wheels</li> <li>4. Worn steering linkage connections</li> <li>5. Worn or broken front wheel bearings</li> <li>6. Loose front wheel</li> <li>7. Steering wheel loose in place</li> <li>8. Blister or bump on tire</li> </ol>	<p>Reduce to the specification            Replace            Adjust</p> <p>Replace            Replace            Retighten            Retighten the nut            Replace tire</p>
<b>Rapid wear or uneven wear of wheel tires (Abnormal or excessive tire wear)</b>	<ol style="list-style-type: none"> <li>1. Wheel tires improperly inflated</li> <li>2. Differences in diameter among four tires</li> <li>3. Worn or loose road wheel bearings</li> <li>4. Wobbly wheel tires</li> </ol>	<p>Adjust tire pressure            Adjust or replace            Replace            Repair or replace</p>

Condition	Possible cause	Correction
Rapid wear or uneven wear of wheel tires (Abnormal or excessive tire wear)	5. Wheel tires improperly "rotated" to result in unbalance 6. Disturbed front wheel alignment 7. Hard driving	Adjust  Adjust as prescribed Replace tire
Steering noise	1. Loose bolts and nuts 2. Loose leaf spring seats 3. Broken or otherwise damaged wheel bearings 4. Worn or sticky tie rod ends 5. Linkage joints needling grease	Retighten Retighten Replace  Replace Lubricate or replace
Too much play in steering	1. Worn wheel bearings . 2. Steering gear box attachments loose 3. Steering gear box adjustments 4. Worn steering shaft joints 5. Worn tie rod ends or drug rod ball joints	Replace wheel bearing Tighten or repair Check and adjust Replace joint Replace tie rod end or tie rod
Poor returnability	1. Bind in tie rod end ball studs 2. Bind in steering column 3. Lack of lubricant steering gear box 4. Disturbed front end alignment  5. Steering gear box adjustment  6. Tires not adequately inflated	Replace tie rod end Repair or replace Check, lubricate or replace Check and adjust front end alignment Check and adjust gear box torque Adjust pressure
Abnormal noise, front end	1. Worn, sticky or loose tie rod ends, drug rod ball joints or axle shaft joints 2. Damaged shock absorbers or mountings 3. Loose stabilizer bar 4. Loose wheel nuts 5. Loose suspension bolts or nuts  6. Broken or otherwise damaged wheel bearings 7. Broken suspension springs	Replace tie rod ends, drug rod or axle shaft joints Replace or repair Tighten bolts or replace bushes Tighten Tighten suspension bolts or nuts Replace  Replace
Wander or poor steering stability	1. Mismatched or uneven tires  2. Loose tie rod ends or drug rod 3. Faulty shock absorber or mounting	Replace tire or inflate tires to proper pressure Replace tie rod end or drug rod Replace absorber or repair mounting

Condition	Possible cause	Correction
Wander or poor steering stability	4. Loose stabilizer bar 5. Broken or sagging springs 6. Steering gear box adjustment 7. Front wheel alignment	Tighten or replace stabilizer bar or bushes Replace spring Check or adjust steering gear box torque Check front wheel alignment
Low or uneven trim height	1. Broken or sagging springs 2. Overloaded 3. Incorrect springs	Replace Check loading Replace
Ride too soft	1. Faulty shock absorbers	Replace
Suspension bottoms	1. Overloaded 2. Faulty shock absorbers 3. Incorrect, broken or sagging springs	Checking loading. Replace Replace
Body leans or sways in corners	1. Loose stabilizer bar 2. Faulty shock absorbers or mounting 3. Broken or sagging springs 4. Overloaded	Tighten stabilizer bar bolts or replace bushes Replace shock absorbers or tighten mounting Replace Check loading

## 2-10. STARTING MOTOR

Condition	Possible cause	Correction
Starter runs but pinion will not mesh into ring gear.	1. Worn pinion of starter clutch. 2. Defective splines resulting in sticky pinion plunging motion. 3. Worn bush. 4. Wrong pinion plunging position. 5. Worn teeth of ring gear.	Replace. Repair or replace. Replace. Adjust Replace.
Starter will not run at all, or runs but runs too slow to crank with full force.	<b>Battery trouble</b> 1. Poor contact in battery terminal connection 2. Loose ground cable connection 3. Battery run down 4. Battery voltage too low due to battery deterioration  <b>Ignition switch trouble</b> 1. Poor contacting action 2. Lead wire socket loose in place 3. Opne-circuit between ignition switch and magnet switch	Repair or retighten  Retighten Recharge Replace  Replace Retighten Repair

Condition	Possible cause	Correction
Starter will not run at all, or runs but runs too slow to crank with full force	<b>Magnet switch trouble</b> 1. Lead wire socket loose in place 2. Burnt contact plate, or poor contacting action 3. Open-circuit in pull-in coil 4. Open-circuit in holding coil  <b>Starter proper trouble</b> 1. Brushes seating poorly or worn down 2. Burnt commutator 3. Open-circuit in armature winding 4. Worn-down starter	Retighten Replace, or repair  Replace Replace  Repair or replace Repair or replace Replace Replace
Starter does not stop running.	1. Fused contact points of magnet-switch contact plate 2. Short-circuit between turns of magnet-switch coil (layer short-circuit) 3. Failure of returning action in ignition switch	Repair or replace  Replace  Replace

## 2-11. ALTERNATOR

Condition	Possible cause	Correction
Battery quickly becomes over-discharged.	1. Loose or broken "V" belt 2. Battery cables loose, corroded or worn 3. Low level of battery electrolyte 4. Defective battery cell plates 5. Insufficient contact in battery terminal connection. 6. Excessive electrical load 7. IC regulator or alternator faulty 8. Defective idle up system	Adjust or replace Repair or replcae Replace Replace the battery Clean and retighten  Check charging system Replace Repair or replace
Charge light does not light with ignition ON and engine off	1. Fuse blown 2. Light burned out 3. Loose wiring connection 4. IC regulator faulty	Check fuse Replace light Tighten loose connection! Replace
Alternator noise	1. Worn, loose or otherwise defective bearings	Replace

## 2-12. WIPER MOTOR

Condition	Possible cause	Correction
Wiper will not run	<ol style="list-style-type: none"> <li>1. Fuse set loose or blown off</li> <li>2. Incomplete metal-to-metal contact in connector.</li> <li>3. Worn or floating brushes</li> <li>4. Dirty or burnt commutator</li> <li>5. Short-circuited or fused field coil</li> <li>6. Loose terminal connection on wiper switch</li> </ol>	Tighten or replace Repair  Replace or repair Repair or replace Replace Repair
Wiper will not stop running	<ol style="list-style-type: none"> <li>1. Defective wiper switch</li> </ol>	Repair or replace
Wiper stops at wrong position	<ol style="list-style-type: none"> <li>1. Improper wiper arm setting</li> <li>2. Cover plate incorrectly positioned in place</li> </ol>	Repair Repair
Poor wiping action	<ol style="list-style-type: none"> <li>1. Insufficient pressure of wiper arm</li> <li>2. Deteriorated or hardened blade</li> <li>3. Blade improperly set</li> <li>4. Windshield dirty with oil</li> </ol>	Replace Replace Repair or replace Clean

## 2-13. FUEL METER

Condition	Possible cause	Correction
Faulty meter indication	<ol style="list-style-type: none"> <li>1. Incomplete metal-to-metal contact in terminal connections</li> <li>2. Defective receiver gauge due to burnt point or deformed bimetal element</li> <li>3. Erratic float movement</li> <li>4. Defective grounding (for float and gauge)</li> </ol>	Retighten  Replace  Repair or replace Repair
No indication	<ol style="list-style-type: none"> <li>1. Open-circuit</li> <li>2. Open-circuited heat wire</li> <li>3. Burnt point</li> <li>4. Deformed bimetal element</li> <li>5. Open-circuited resistor</li> </ol>	Repair Replace Replace Replace Replace

## 2-14. SPEEDOMETER

Condition	Possible cause	Correction
Faulty indication	<ol style="list-style-type: none"><li>1. Damaged speedometer drive or driven gear</li><li>2. Defective drive cable</li><li>3. Drive cable incompletely or improperly tied into the meter</li><li>4. Defective speedometer</li></ol>	Replace Replace Set right  Replace
Speedometer noise	<ol style="list-style-type: none"><li>1. Inadequately lubricated or defective cable</li><li>2. Not enough oil in transfer</li></ol>	Lubricate or replace Replenish

## 2-15. WATER TEMPERATURE METER

Condition	Possible cause	Correction
Faulty indication	<ol style="list-style-type: none"><li>1. Incomplete metal-to-metal contact in terminal connections</li><li>2. Receiver gauge defective (due to burnt point or deformed bimetal element)</li><li>3. Defective temperature gauge</li></ol>	Repair and tighten  Replace  Replace
No indication	<ol style="list-style-type: none"><li>1. Open-circuit</li><li>2. Defective receiver gauge (open-circuited heat wire, deformed bimetal element or pointer)</li><li>3. Defective temperature gauge</li></ol>	Repair Replace  Replace



## SECTION 3

# ENGINE

### CONTENTS

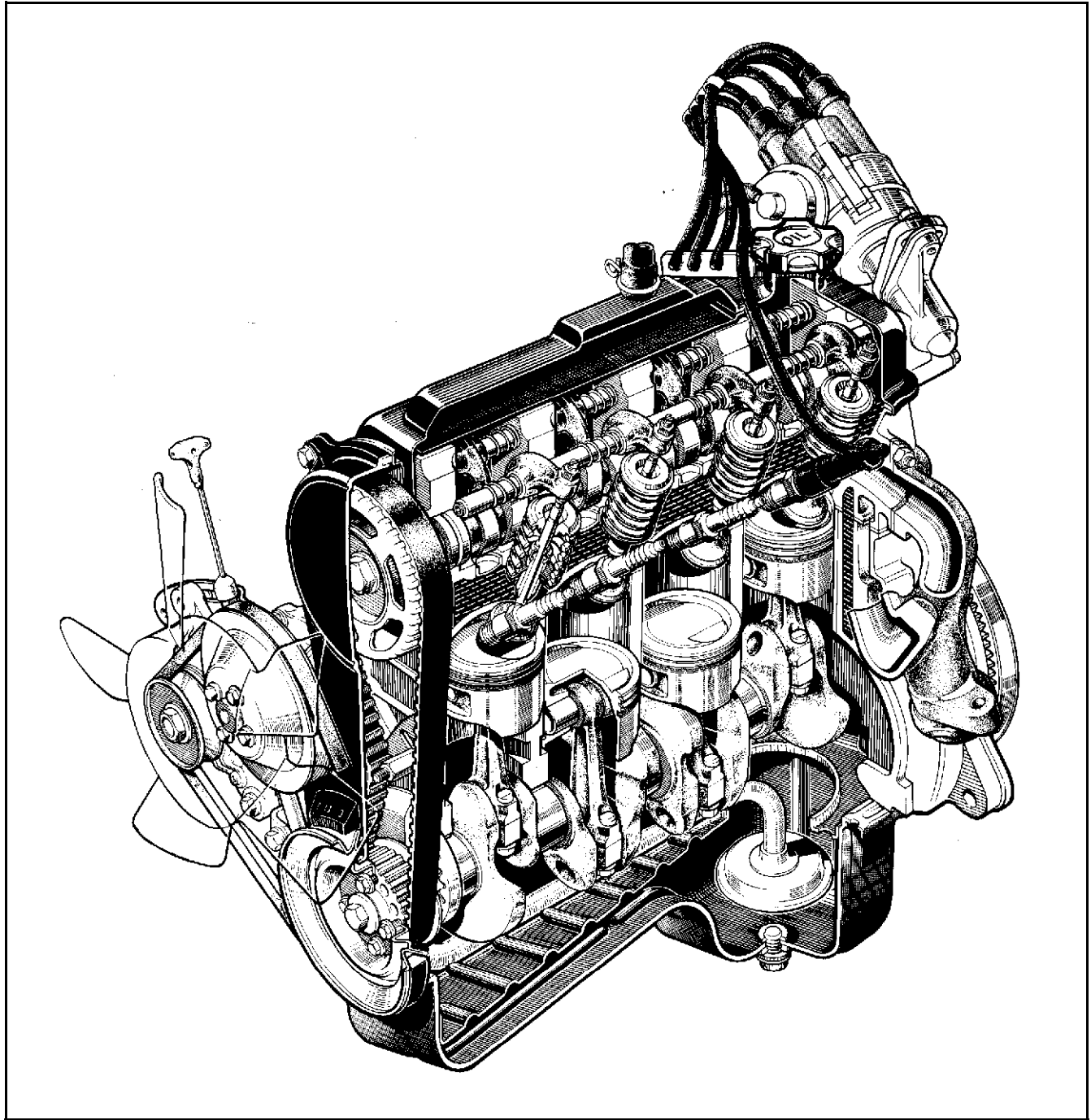
3-1.	GENERAL DESCRIPTION .....	3-2
3-2.	ENGINE SERVICES NOT REQUIRING ENGINE REMOVAL .....	3-5
3-3.	ENGINE REMOVAL .....	3-6
3-4.	ENGINE DISASSEMBLY .....	3-9
3-5.	INSPECTION OF ENGINE COMPONENTS .....	3-17
3-6.	ENGINE REASSEMBLY .....	3-35
3-7.	ENGINE INSTALLATION .....	3-53
3-8.	ENGINE MAINTENANCE SERVICE .....	3-53
3-9.	RECOMMENDED TORQUE SPECIFICATIONS .....	3-58

### 3-1. GENERAL DESCRIPTION

#### 1) Engine

The engine is water-cooled, in line 4 cylinders, 4 stroke cycle gasoline unit with its S.O.H.C (Single overhead camshaft) valve mechanism arranged for "V"-type valve configuration.

This single overhead camshaft is mounted over the cylinder head; it is driven from crankshaft through timing belt, and no push rods are provided in the valve train system.



*Fig. 3-1-1*

## 2) Engine Lubrication

The oil pump is of a trochoid type, and mounted on the crankshaft at the crankshaft pulley side.

Oil is drawn up through the oil pump strainer and passed through the pump to the oil filter.

The filtered oil flows into two paths in cylinder block.

In one path, oil reaches the crankshaft journal bearings.

Oil from the crankshaft journal bearings is supplied to the connecting rod bearings by means of intersecting passages drilled in the crankshaft, and then injected from a small hole provided on the big end of connecting rod to lubricate piston, rings, and cylinder wall.

In another path, oil goes up to the cylinder head and lubricates rocker arms, valves and camshaft, etc., after passing through the internal oilway of rocker arm shafts.

An oil relief valve is provided on the oil pump. This valve starts relieving oil pressure when the pressure comes over about  $3.0 \text{ kg/cm}^2$  (42.7 psi, 300 kPa). Relieved oil drains back to the oil pan.

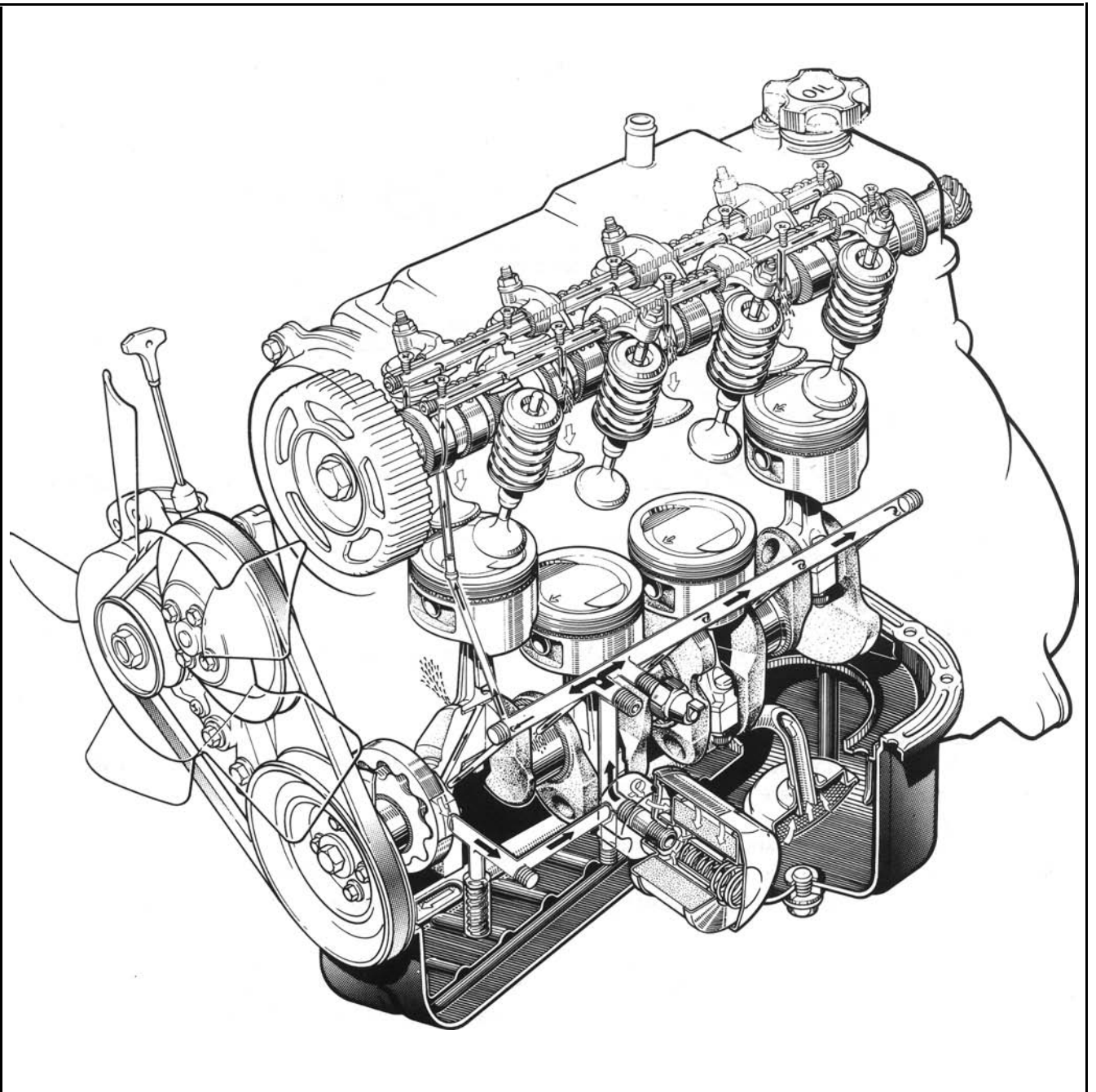


Fig. 3- 1-2

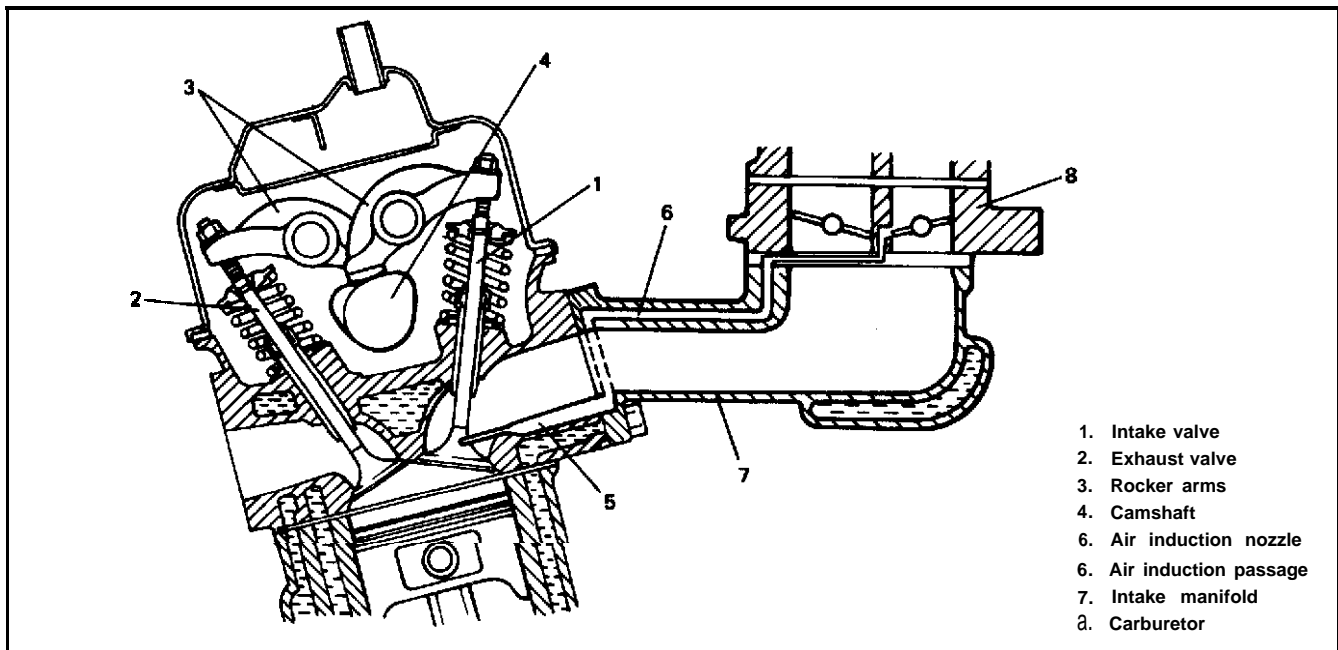
### 3) Cylinder Head and Valve Train

The cylinder head is made of cast aluminum alloy and has four combustion chambers arranged in-line. Each combustion chamber has an intake and an exhaust ports.

Moreover, as shown in Figure 3-1-3, the air induction nozzle is provided near each intake valve. During intake stroke of the engine, air/fuel mixture enters into the combustion chamber from carburetor through intake manifold and intake valve. At the same time, air flows to the air induction nozzle through carburetor and air induction passage in the intake manifold, and jets into the combustion chamber.

The air jetted into the combustion chamber accelerates the mixture swirl to improve the combustion efficiency.

A single overhead camshaft driven by the crankshaft through the timing belt is mounted on the cylinder head. The camshaft has eight cams, and each cam operates the intake or exhaust valve through rocker arm. The valve lash can be adjusted by turning the adjusting screw on the rocker arm after loosening the lock nut.



**Fig. 3-1-3** Cylinder head and valve train

### 4) Cylinder Block

The cylinder block is made of cast aluminum alloy and has 4 cylinders arranged "In-Line". A cylindrical cast iron sleeve is installed in each cylinder.

### 5) Crankshaft and Main Bearings

A monoblock casting crankshaft is supported by 5 main bearings which are of precision insert type. Four crank pins on the crankshaft are positioned  $180^\circ$  apart.

### 6) Pistons, Rings, Piston Pins and Connecting Rods

The piston is cast aluminum alloy, and has two compression rings and one oil ring.

Among two compression rings (top and 2nd rings), the top ring is plated with hard chromium for improvement in abrasion resistance.

The oil ring consists of two rails and one spacer.

The piston pin is offset. 0.5 mm towards the major thrust side. This allows a gradual change in thrust pressure against the cylinder wall as the piston travels its path. Pins are chromium steel and have a floating fit in the pistons. They are retained in the connecting rods by a press fit. The connecting rods are made of forged steel, and the rod bearings are of precision insert type.

### 3-2. ENGINE SERVICES NOT REQUIRING ENGINE REMOVAL

The following parts of components do not require engine removal to receive services (replacement, inspection or adjustment):

Part or Component	Nature of Service
1. Spark plug	Replacement or inspection
2. Distributor	Replacement, inspection or adjustment
3. Exhaust manifold	Replacement or inspection
4. Oil filter	Replacement
5. Oil pressure unit	Replacement
6. Cylinder head cover	Replacement
7. Rocker shaft	Replacement or inspection
8. Rocker-arm	Replacement or inspection
9. Rocker-arm spring	Replacement or inspection
10. Cam shaft	Replacement or inspection (Cylinder head removal required)
11. Cylinder head	Replacement or inspection
12. Radiator	Replacement or inspection (Cooling fan and fan shroud removal required)
13. Cooling fan	Replacement
14. Camshaft timing belt pulley	Replacement or inspection
15. Crankshaft timing belt pulley	Replacement or inspection
16. Timing belt	Replacement or inspection (Cooling fan and fan shroud removal required)
17. Fuel pump	Replacement
18. Carburetor	Replacement, inspection or adjustment
19. Intake manifold	Replacement
20. Alternator	Replacement or inspection
21. Starter motor	Replacement or inspection
22. Fan belt	Replacement, inspection or tension adjustment
23. Water pump	Replacement (Cooling fan and fan shroud removal required)
24. Pulleys (crank, generator, fan)	Replacement
25. Timing belt cover	Replacement (Cooling fan and fan shroud removal required)
26. Water hose	Replacement or inspection
27. Oil pan, oil strainer, and oil pump	Replacement or inspection
28. Piston and connecting rod	Replacement or inspection (Cylinder head and oil pan removal required)

### 3-3. ENGINE REMOVAL

- 1) Disconnect negative (–) and positive (+) cords from battery terminals.
- 2) From starter motor terminals, disconnect black/yellow lead wire and positive (+) battery cord.
- 3) Disconnect coupler and white lead wire from alternator terminals.
- 4) Disconnect lead wires from water temperature gauge and thermal switch. The gauge and switch are on intake manifold. Disconnect earth lead wire from intake manifold.
- 5) Disconnect couplers of carburetor fuel cut solenoid valve, vent solenoid valve and mixture control solenoid valve, and disconnect couplers from TWSVS and VSV.
- 6) Remove warm air hose.
- 7) Disconnect breather hose from air cleaner case.
- 8) Remove air intake case from carburetor body and air inlet hose.
- 9) Disconnect accelerator cable from carburetor.
- 10) Disconnect vacuum hoses of TCAC and canister from intake manifold.
- 11) Remove fuel tank filler cap to release fuel vapor pressure in fuel tank. After releasing, reinstall it. Disconnect fuel feed and return hoses from fuel pump.
- 12) Disconnect lead wire from oil pressure unit terminal and oxygen sensor lead wire at the coupler.
- 13) Disconnect lead wires of back-up light switch and fifth switch at their couplers.
- 14) Disconnect distributor lead wire at the coupler.
- 15) Pull off high-tension cord from ignition coil.
- 16) Loosen radiator drain plug to drain cooling water,
- 17) Disconnect water hoses from thermostat cap and water inlet pipe. After removing cooling fan & clutch and fan shroud, remove radiator.

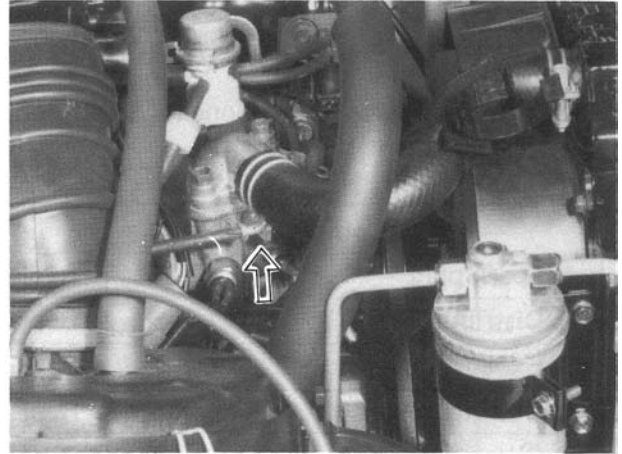


Fig. 3-3-1

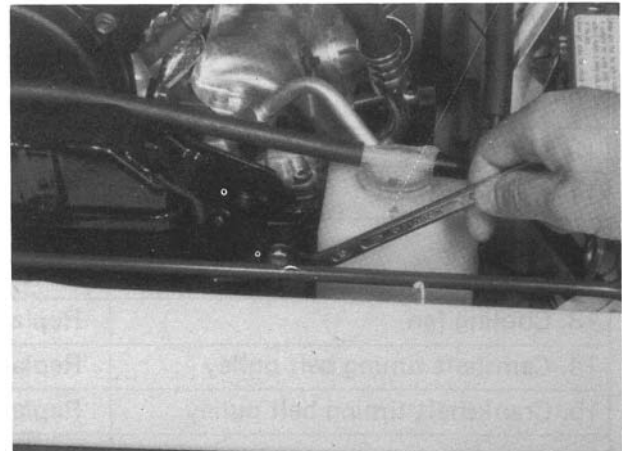


Fig. 3-3-2

- 16) Disconnect heater hoses from heater unit outlet pipe and intake manifold.



Fig. 3-3-3

- 19) Disconnect brake booster vacuum hose from pipe.
- 20) Disconnect coupler of lead wire (black) from distributor gear case.
- 21) Remove 4 bolts fastening gear shift lever boot No. 2 and move the boot upward.

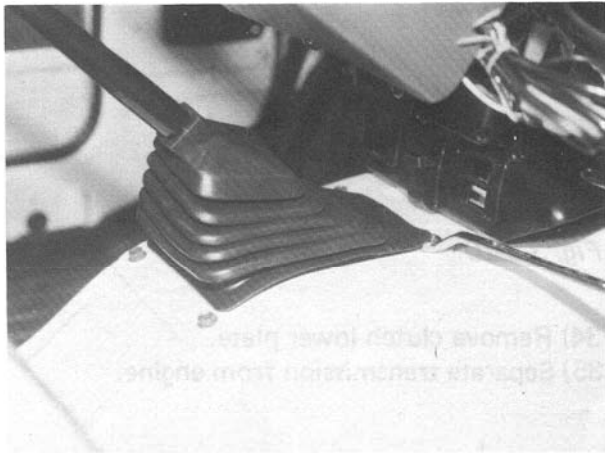


Fig. 3-3-4

- 22) Move gear shift lever boot No. 1 to upper side of shift lever.
- 23) Loosen 3 bolts tightening gear shift lever case cover and take shift lever out of lever case.

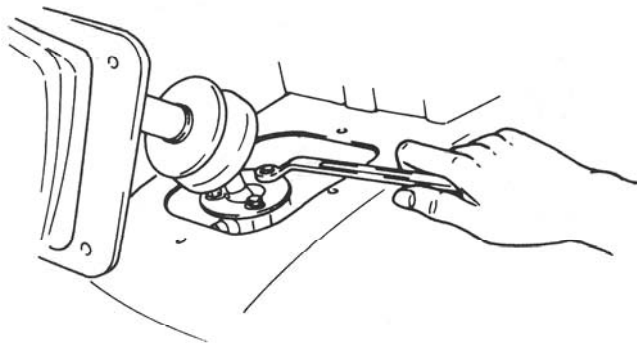


Fig. 3-3-5

- 24) Raise vehicle.
- 25) Sever exhaust manifold from muffler by undoing joint.

- 26) Disconnect clutch cable from engine mounting bracket and clutch release lever.
- 27) Loosen drain plug to drain transmission oil.
- 28) Remove propeller shaft interconnecting transmission case and transfer case.
- 29) By using a chain block, hold engine so that the engine is kept from falling.

**NOTE:**

**engine at two hooks provided, one on inlet-manifold side and the other on exhaust-manifold side.**

- 30) Remove exhaust center pipe mounting bracket and 4 transmission mounting bolts.

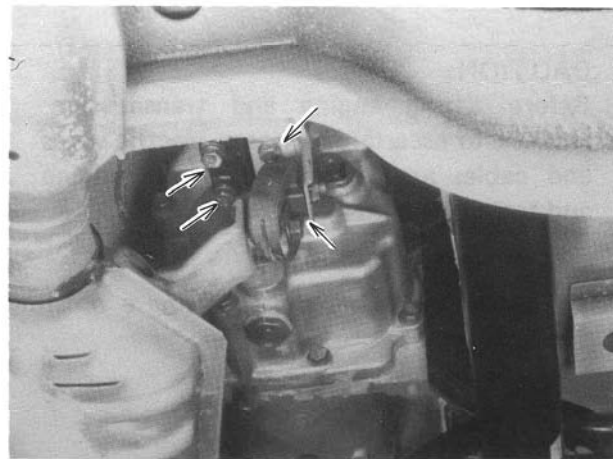


Fig. 3-3-6

- 31) Remove the pipe connected to chassis under the transmission case.

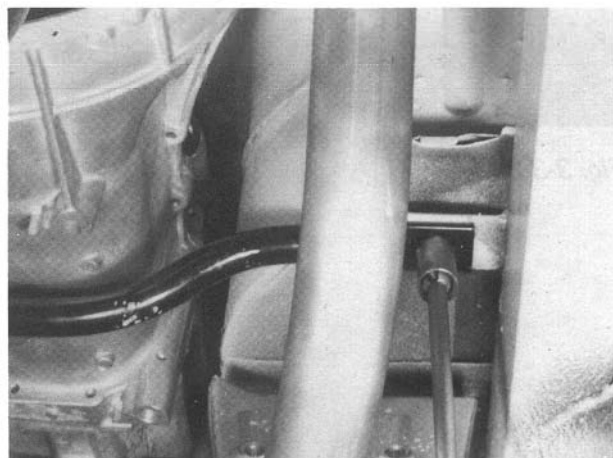


Fig. 3-3-7

32) Lower vehicle and remove 4 bolts securing right and left engine mounting brackets (body side).

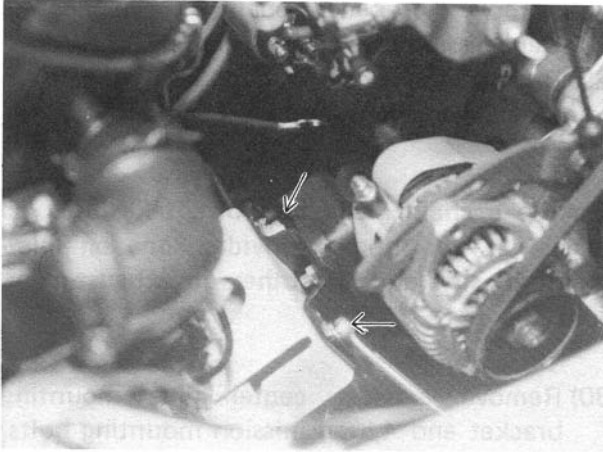


Fig. 3-3-8

**CAUTION:**

Before lifting engine and transmission, recheck to ascertain all hoses, electric wires and cables are disconnected from engine and transmission.

33) Take down engine by operating a hoisting means.

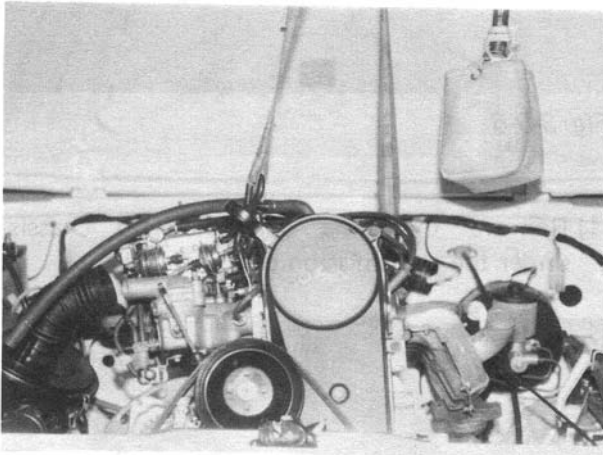


Fig. 3-3-9

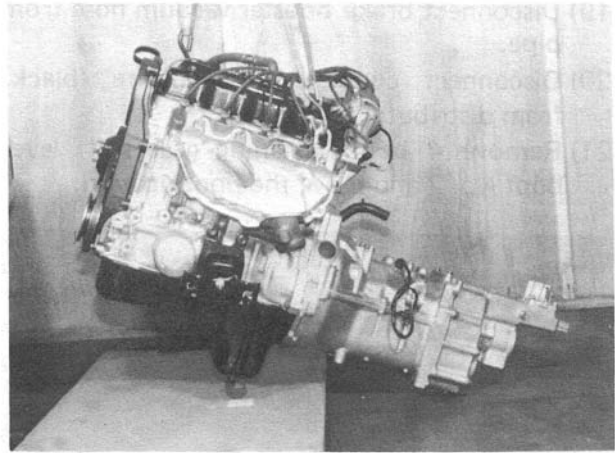


Fig. 3-3-10

34) Remove clutch lower plate.

35) Separate transmission from engine.

Throughout this MANUAL, 4 cylinders of engine are identified by numbers: No. 1, No. 2, No. 3 and No. 4 as counted from front end.

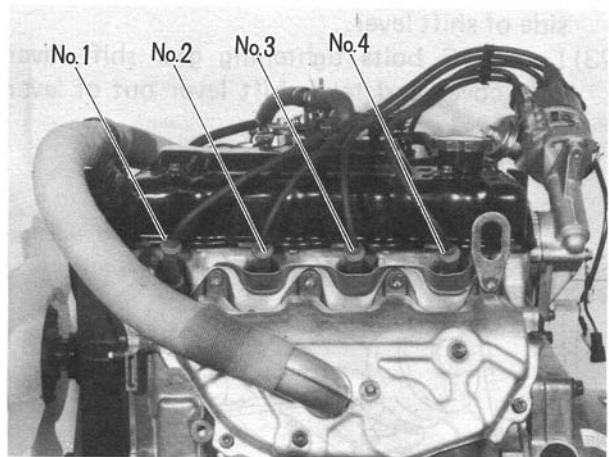


Fig. 3-3-11



### 3-4. ENGINE DISASSEMBLY

**NOTE:**

- Observe critically before starting to remove a component or part by loosening bolts, nuts and the like. What you may find before and during disassembly is valuable information necessary for successful reassembly.
- Be careful in handling aluminum-alloy parts. They are softer than steel or cast-iron parts and their finished surfaces more easily take scratch marks.
- Have trays and pans ready for setting aside disassembled parts in an orderly manner. Place parts in trays and pans in such a way that they can be readily identified. Put match marks or tags on them, as necessary, so that they will go back to where they came from.

Carry out engine disassembly in the following sequence :

- 1) Loosen drain plug and drain out engine oil.

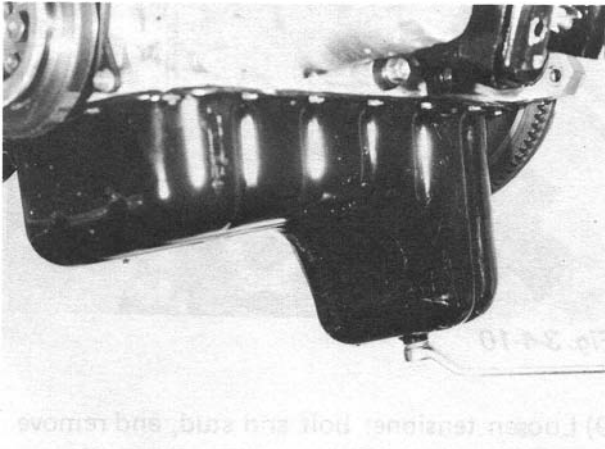


Fig. 3-4-1

- 2) Remove clutch cover and clutch disc.

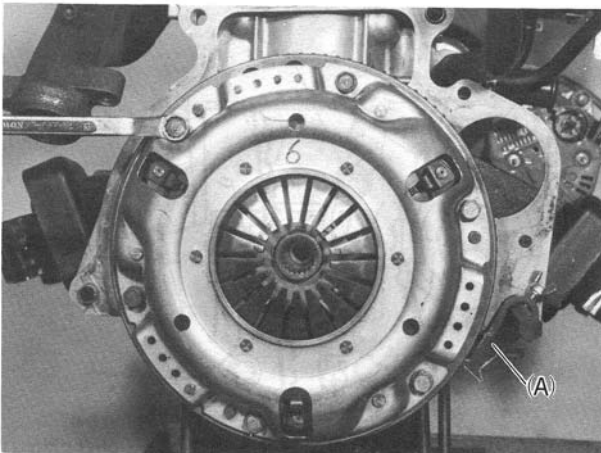


Fig. 3-4-2 (A) Flywheel holder (Special tool 09924-17810)

- 3) Remove distributor assembly.

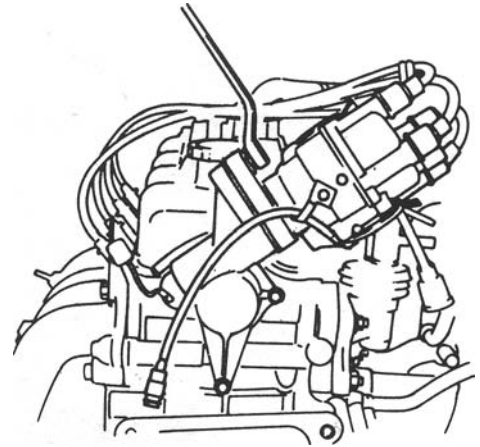


Fig. 3-4-3

- 4) Remove the fuel pump and rod.

**NOTE:**

When removing pump and distributor gear case, place waste or receiver under gear case.

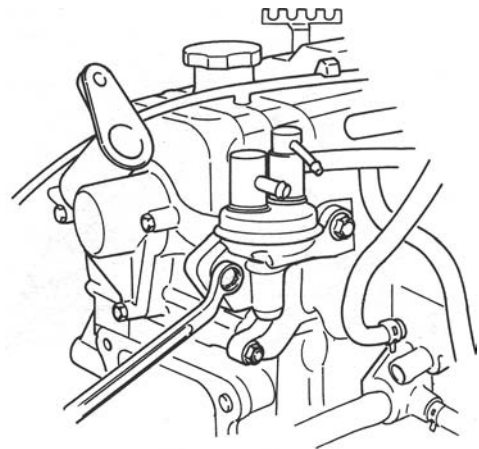


Fig. 3-4-4

- 5) Take down distributor case.

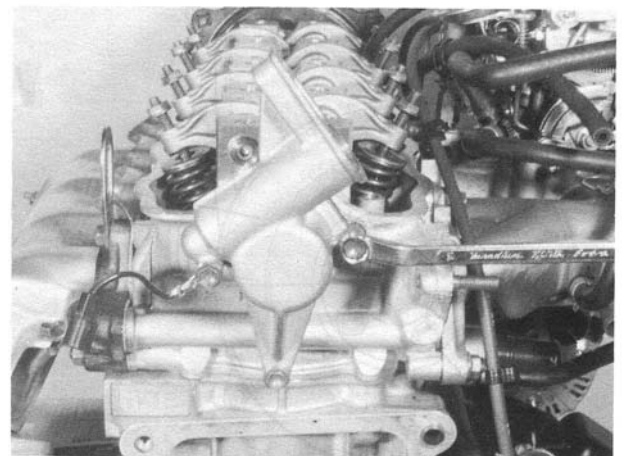


Fig. 3-4-5

6) Take down alternator and water pump pulley.

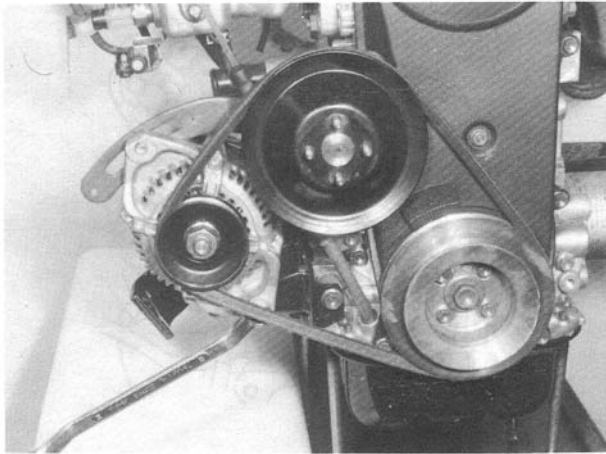


Fig. 3-4-6

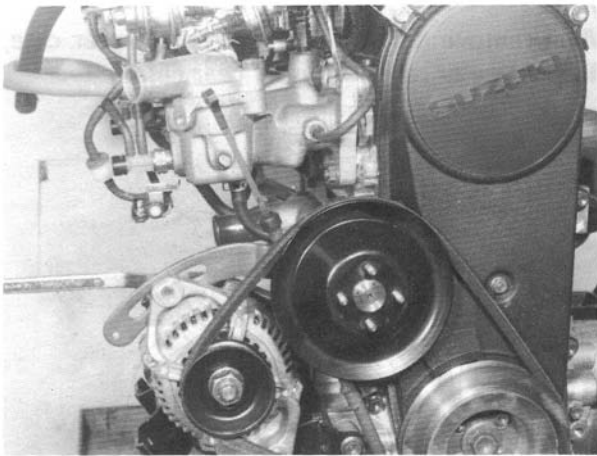
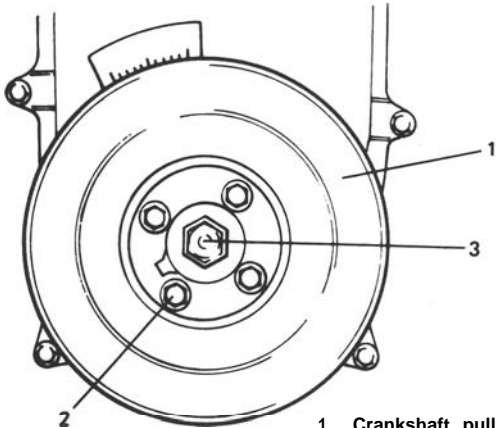


Fig. 3-4-7

7) Remove crankshaft pulley by removing 4 pulley bolts, with special tool (A) hitched to flywheel so that crankshaft will not turn. The crank timing belt pulley bolt at the center needs not to be loosened.



1. Crankshaft pulley
2. Crankshaft pulley bolt
3. Crank timing belt pulley bolt

Fig. 3-4-8

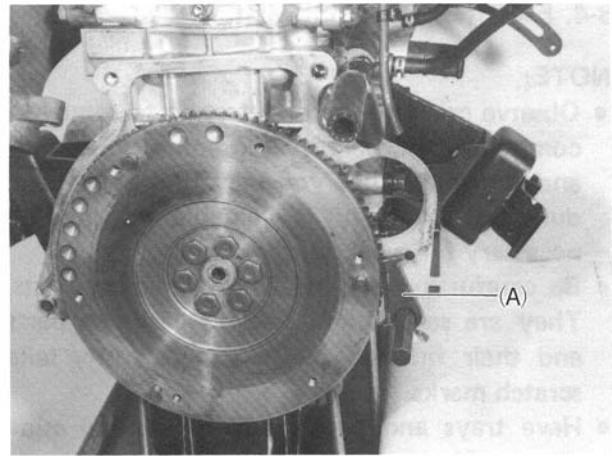


Fig. 3-4-9 (A) Flywheel holder (Special tool 09924-17810)

8) Remove outside cover on timing belt.

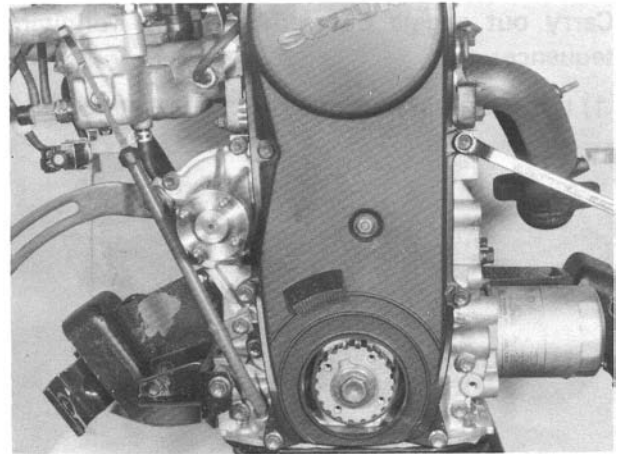
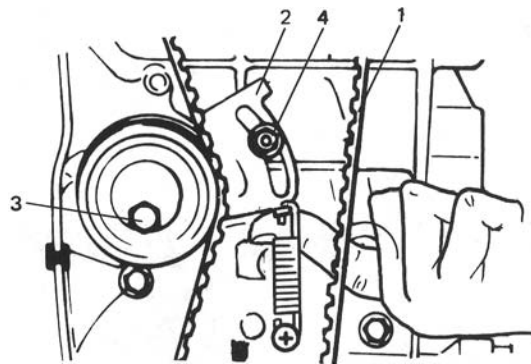


Fig. 3-4-10

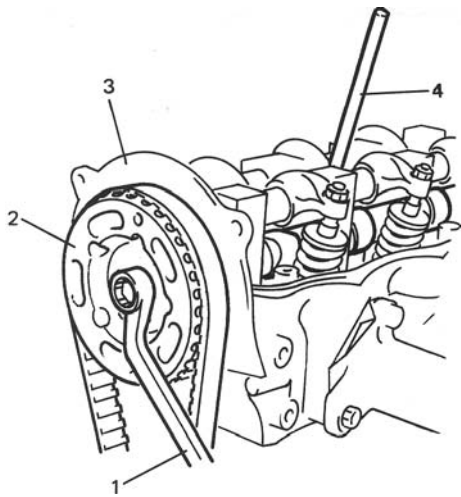
9) Loosen tensioner bolt and stud, and remove belt from crank timing belt pulley and camshaft pulley after pushing up tensioner plate fully by finger as shown in Figure 3-4-11.



1. Timing belt
2. Tensioner plate
3. Tensioner bolt
4. Tensioner stud

Fig. 3-4-11

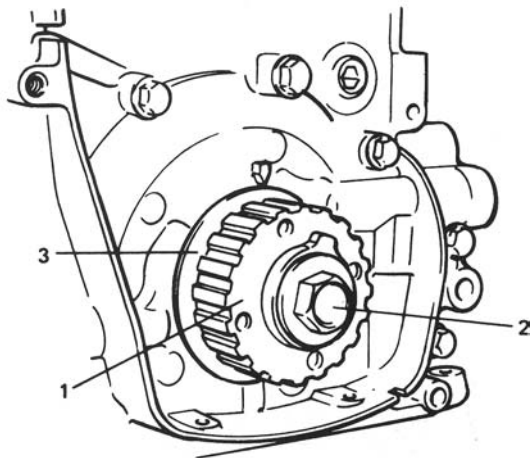
- 10) Remove timing belt tensioner, tensioner plate, and tensioner spring.
- 11) Remove camshaft timing belt pulley by locking camshaft (insert general rod into the camshaft hole) as shown below.



- 1. Wrench
- 2. Camshaft timing belt pulley
- 3. Timing belt inside cover
- 4. General rod

Fig. 3-4-12

- 12) Using flywheel holder (A) (Special tool), remove crankshaft timing belt pulley bolt, pulley and timing belt guide with crankshaft locked.



- 1. Crankshaft timing belt pulley
- 2. Pulley bolt
- 3. Timing belt guide

Fig. 3-4-13

- 13) Remove crankshaft timing belt pulley key.
- 14) Remove timing belt inside cover.

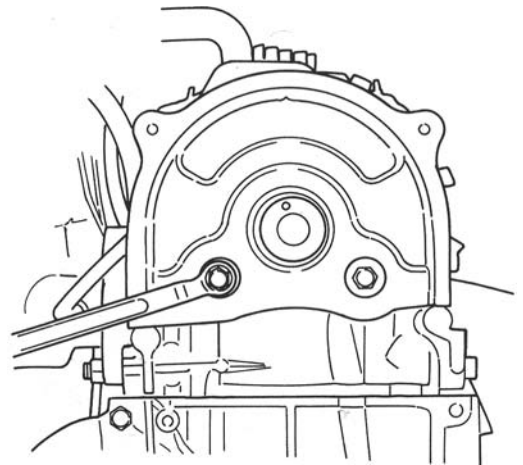


Fig. 3-4-14

- 15) Remove water pump.

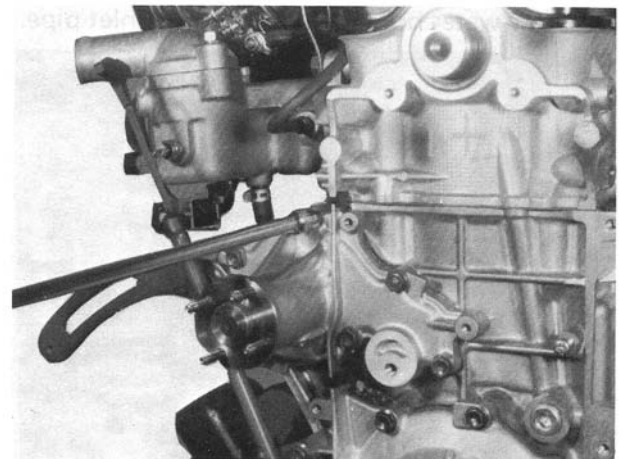


Fig. 3-4-15

- 16) Remove exhaust manifold cover.
- 17) Take off exhaust manifold and its gasket.

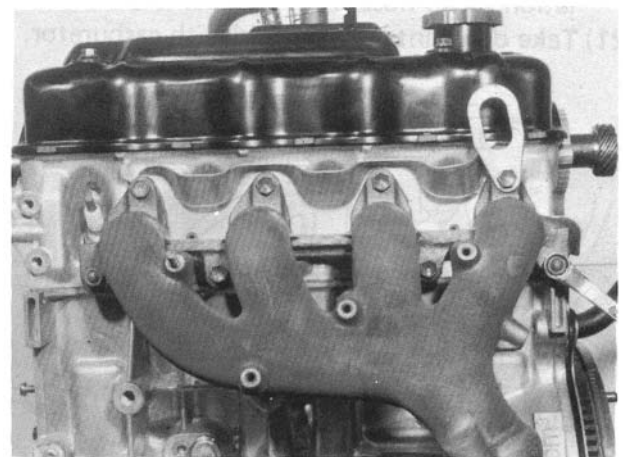


Fig. 3-4-16

18) Using special tool (C), remove oil filter.

**NOTE:**

Be careful not to spill oil when removing filter.

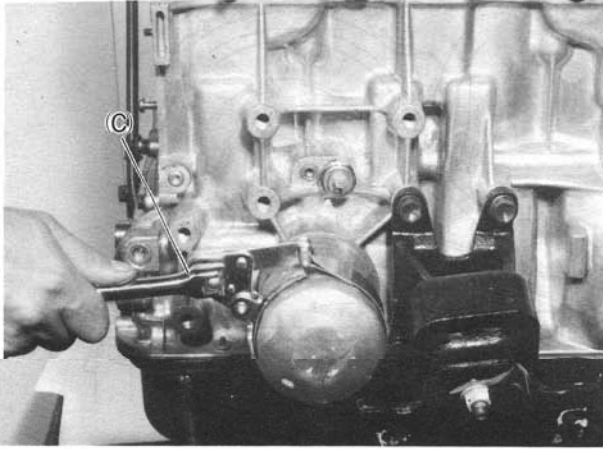


Fig. 3-4- 17 (C) Oil filter wrench (099 15-47310)

19) Draw water hoses off water pump inlet pipe.

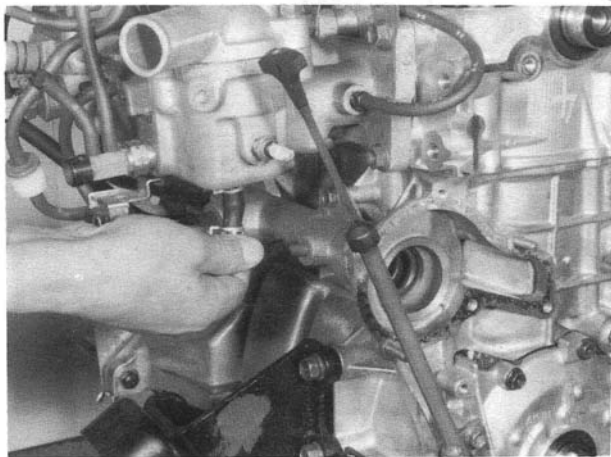


Fig. 3-4- 18

20) Disconnect PCV (Positive crankcase ventilation valve) hose from cylinder head cover.

21) Take down intake manifold with carburetor.

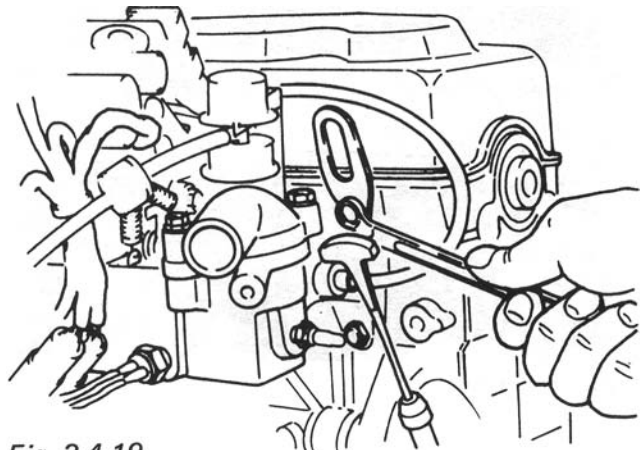


Fig. 3-4-19

22) Remove water inlet pipe.

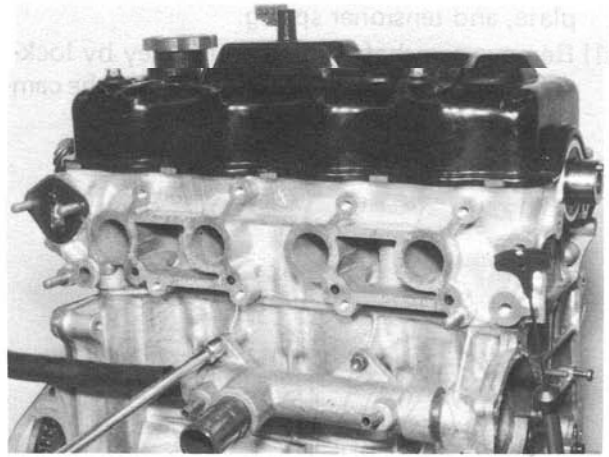


Fig. 3-4-20

23) Take off cylinder head cover.

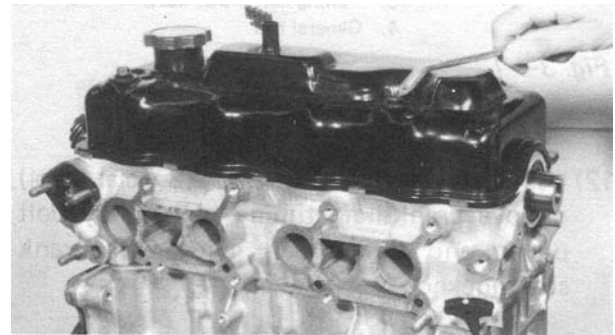


Fig. 3-4-2 1

24) Loosen 8 valve adjusting screws fully. Leave screws in place.

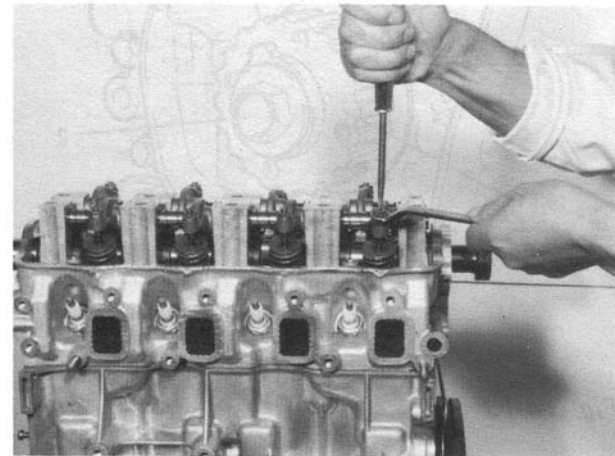


Fig. 3-4-22

25) Loosen rocker arm shaft securing screws (10 pcs).

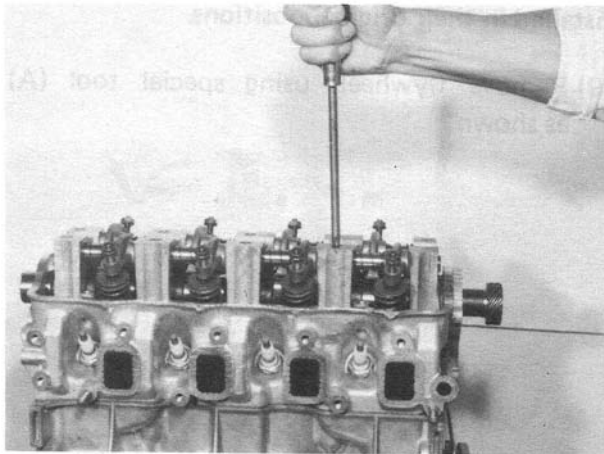


Fig. 3-4-23

26) While drawing out rocker arm shaft, separate valve rocker arms and rocker arm springs.

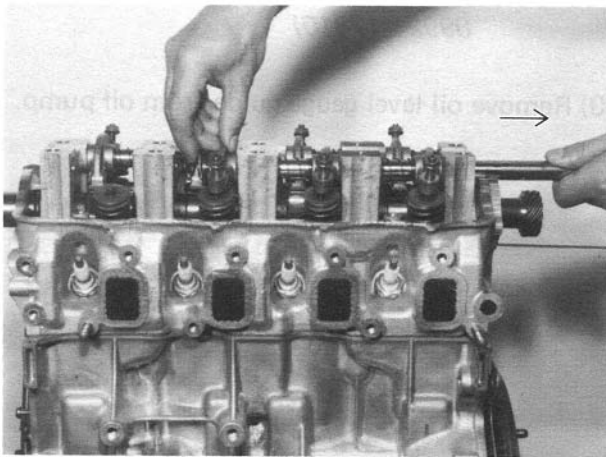


Fig. 3-4-24

27) Draw camshaft out toward rear end (transmission case side).

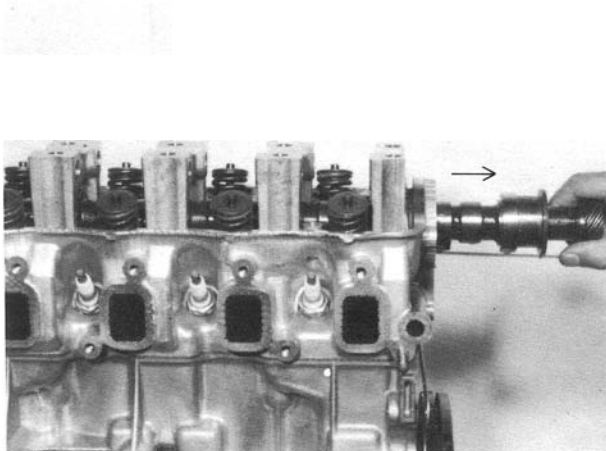


Fig. 3-4-25

28) Remove cylinder head.

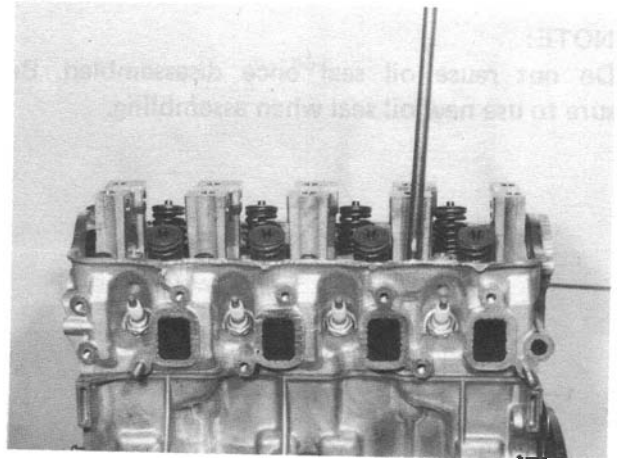
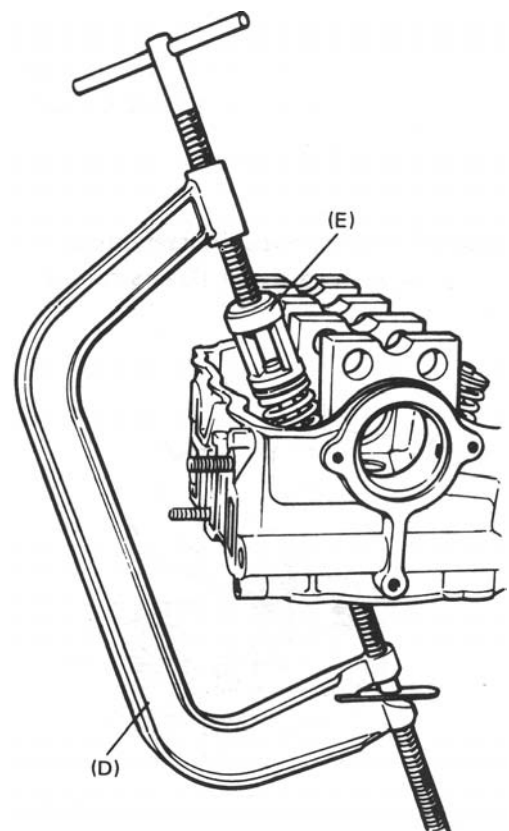


Fig. 3-4-26

a) Use valve lifter (D), (E) to compress valve spring in order to free valve cotter pieces for removal. In this way, remove valve spring and valves.



(D) Valve lifter  
(Special tool 09916-14510)

(E) Valve lifter attachment  
(Special tool 0991648210)

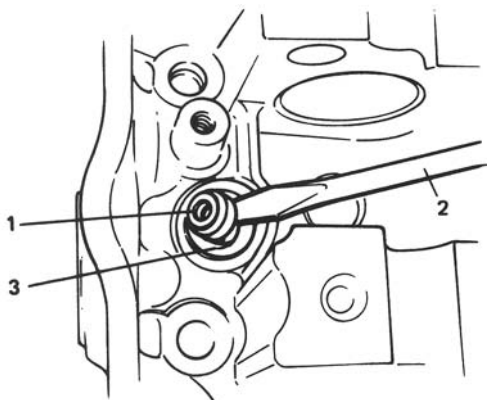
Fig. 3-4-27



b) Remove valve stem oil seal from valve guide, and then valve spring seat.

NOTE:

**Do not reuse oil seal once disassembled. Be sure to use new oil seal when assembling.**



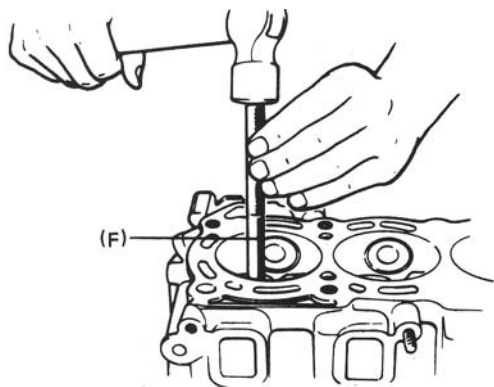
- 1. Valve stem oil seal
- 2. Blade screw driver
- 3. Valve spring seat

**Fig. 3-4-28**

c) Using special tool (F), drive valve guide out from combustion chamber side to valve spring side (Figure 3-4-29).

NOTE:

**Do not reuse valve guide once disassembled. Be sure to use new valve guide (Oversize) when assembling.**



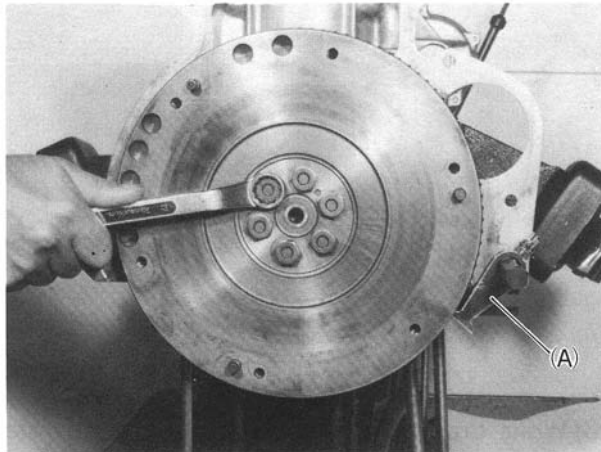
(F) Valve guide remover (Special tool 09916-44511)

**Fig. 3-4-29**

NOTE:

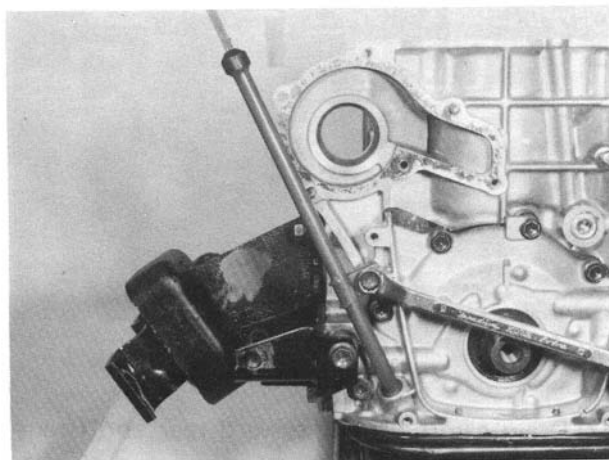
**Place disassembled parts except valve stem seal and valve guide in order, so that they can be installed in their original positions.**

29) Remove flywheel, using special tool (A) as shown.



**Fig. 3-4-30 (A) Flywheel holder (Special tool 09924-17810)**

30) Remove oil level gauge guide from oil pump.



**Fig. 3-4-3 1**

31) Take down oil pan.

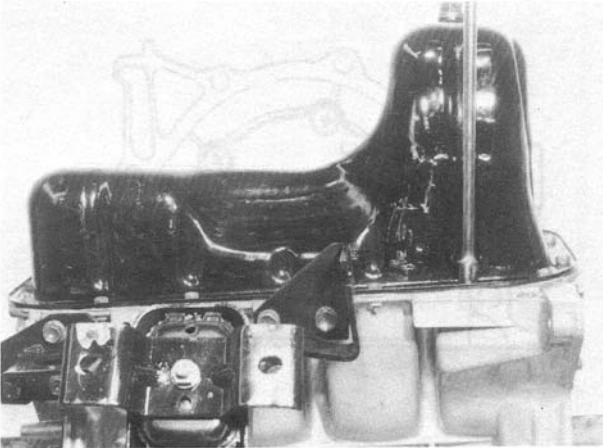


Fig. 3-4-32

32) Remove oil pump strainer.

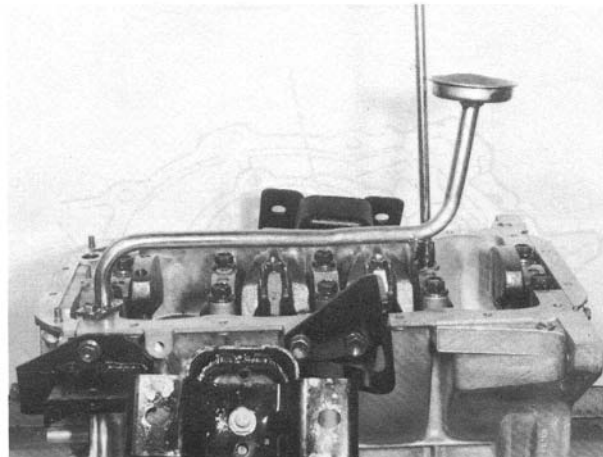


Fig. 3-4-33

33) Remove connecting rod bearing caps.

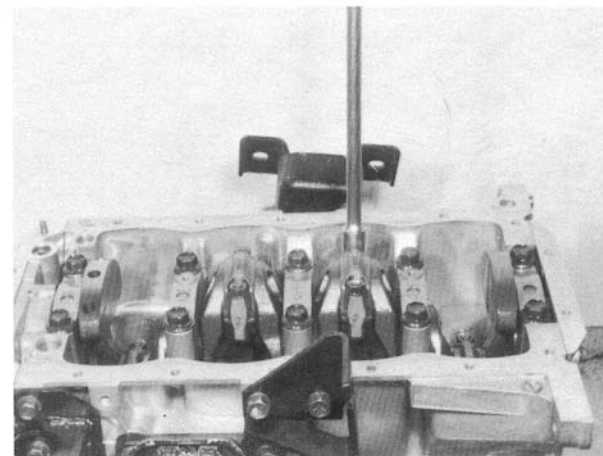
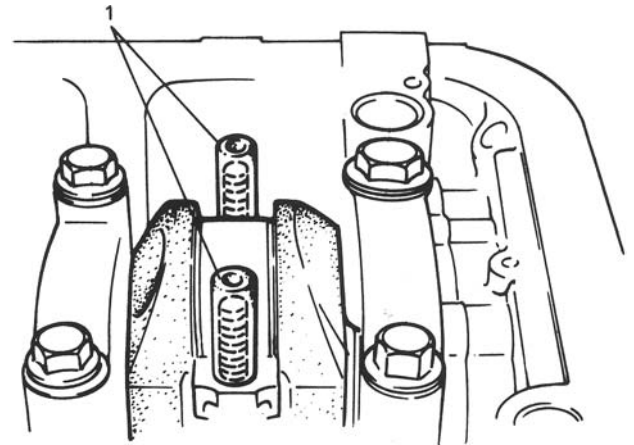


Fig. 3-4-34

34) Install guide hose over threads of rod bolts. This is to prevent damage to bearing journal and cylinder wall when removing connecting rod.



1. Guide hoses

Fig. 3-4-35

35) Decarbon top of cylinder bore, before removing piston from cylinder.

36) Push piston and connecting rod assembly out through the top of cylinder bore.

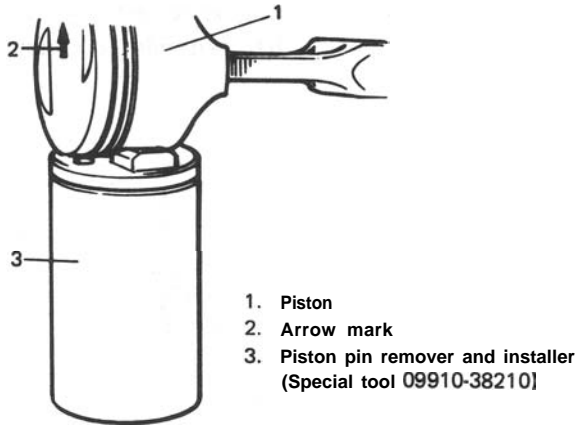
**CAUTION:**

- Before pulling piston out, scribe cylinder number on its crown.
- Be sure to identify each bearing cap for its connecting rod by using cylinder number. Set cap and rod aside in combination.

a) Using piston ring expander, remove two compression rings (Top and 2nd) and oil ring from piston.

b) Remove piston pin from connecting rod.

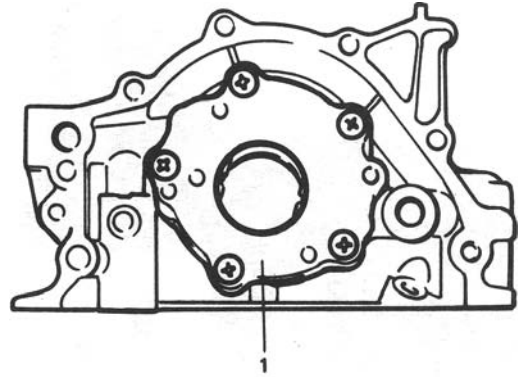
Fit piston and connecting rod assembly to special tool (Fig. 3-4-36), and then press piston pin out of connecting rod by using arbor press (Fig. 3-4-37).



- 1. Piston
- 2. Arrow mark
- 3. Piston pin remover and installer (Special tool 09910-38210)

Fig. 3-4-36

a) Remove oil pump rotor plate.



- 1. Rotor plate

Fig. 3-4-39

Press

- 1. Driver handle
- 2. Piston
- 3. Piston pin
- 4. Piston pin guide
- 5. Base
- 6. Support

NOTE:  
Items 1, 4, and 5 are in Special tool (09910-38210).

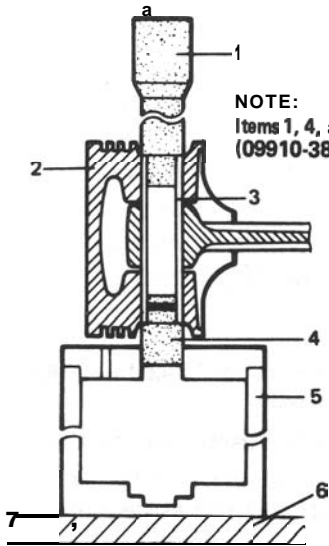
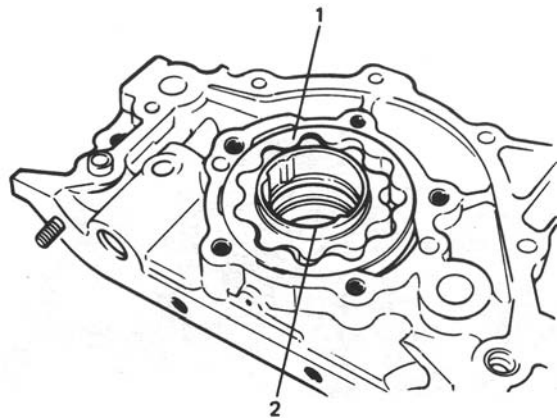


Fig. 3-4-37

b) Remove outer rotor and inner rotor.



- 1. Outer rotor
- 2. Inner rotor

Fig. 3-4-40

37) Remove oil pump assembly.

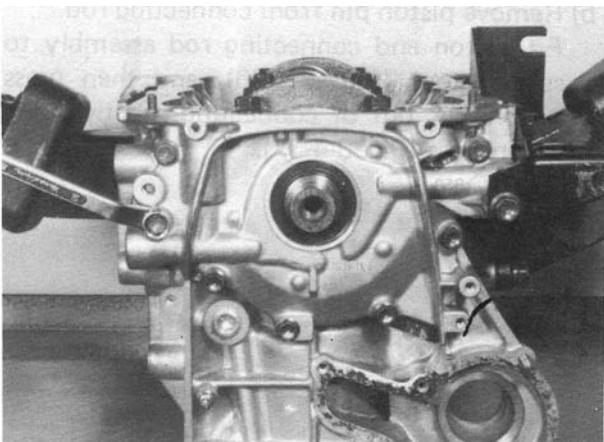


Fig. 3-4-38



38) Remove oil seal housing.

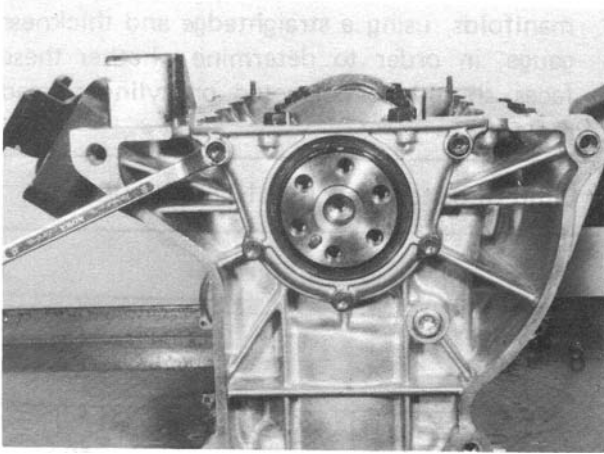


Fig. 3-4-41

39) Remove crankshaft bearing caps, and take out crankshaft.

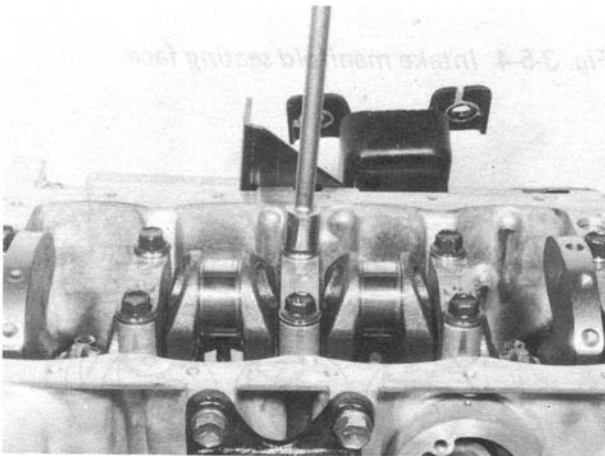


Fig. 3-4-42

### 3-5. INSPECTION OF ENGINE COMPONENTS

#### NOTE:

- During and immediately after disassembly, inspect cylinder block and head for evidence of water leakage or damage and, after washing them clean, inspect more closely.
- Wash all disassembled parts clean, removing grease, slime, carbon and scales, before inspecting them to determine whether repair is necessary or not. Be sure to de-scale water jackets.
- Use compressed air to clear internal oil holes and passages.
- Do not disturb set combinations of valves, bearings and bearing caps, etc. Have the sets segregated and identified.

#### Cylinder Head

- Remove all carbon from combustion chambers.

#### NOTE:

Do not use any sharp-edged tool to scrape off the carbon. Be careful not to scuff or nick metal surfaces when decarboning. This applies to valves and valve seats, too.

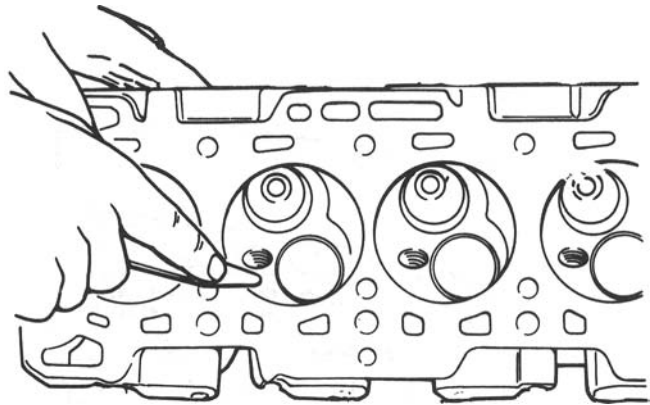


Fig. 3-5-1

- Check cylinder head for cracks in intake and exhaust ports, combustion chambers, and head surface.

- Flatness of gasketed surface:  
Using a straightedge and thickness gauge, check surface at a total of 6 locations. If the limit stated below, is exceeded, correct gasketed surface with a surface plate and abrasive paper of about # 400 (Waterproof silicon carbide abrasive paper): place paper on and over surface plate, and rub gasketed surface against paper to grind off high spots. Should this fail to reduce thickness gauge readings to within the limit, replace cylinder head.

Leakage of combustion gases from this gasketed joint is often due to a warped gasketed surface; such leakage results in reduced power output.

Limit of distortion	0.05 mm (0.002 in.)
---------------------	---------------------

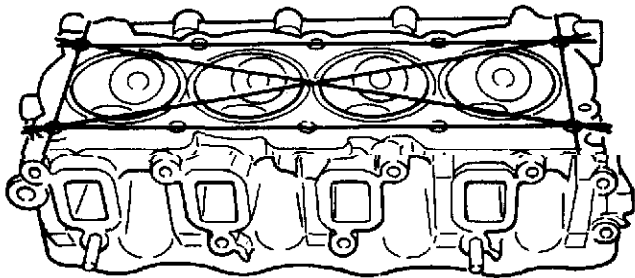


Fig. 3-5-2

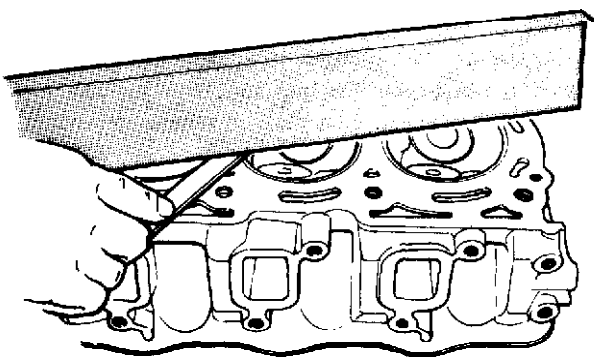


Fig. 3-5-3

- Distortion of manifold seating faces:  
Check seating faces of cylinder head for manifolds, using a straightedge and thickness gauge, in order to determine whether these faces should be corrected or cylinder head replaced.

Limit of distortion	0.10 mm (0.004 in.)
---------------------	---------------------

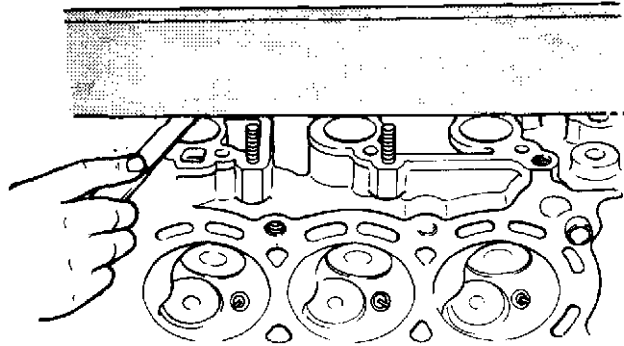


Fig. 3-5-4 In take manifold seating face

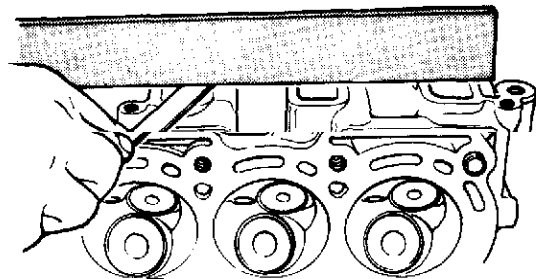


Fig. 3-5-5 Exhaust manifold seating face

### Rocker-Arm Shaft and Rocker Arms

- Shaft-to-arm clearance (IN & EX):  
Using a micrometer and a bore gauge, measure

The difference between two readings is the specified.

If the limit is exceeded, replace shaft or arm,

Item	Standard	Limit
Rocker arm I.D.	16.000 – 16.018 mm (0.629 – 0.630 in.)	
Rocker arm Shaft dia.	15.973 – 15.988 mm (0.628 – 0.629 in.)	
Arm-to-Shaft clearance	0.012 – 0.045 mm (0.0005 – 0.0017 in.)	0.08 mm (0.0035 in.)

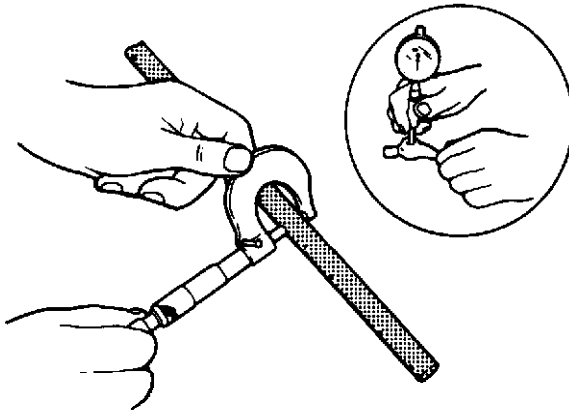


Fig. 3-5-6

- Runout of rocker-arm shaft:  
Using "V" blocks and dial gauge, check runout. If runout exceeds the limit, replace rocker arm shaft.

Runout limit	0.12 mm (0.004 in.)
--------------	---------------------

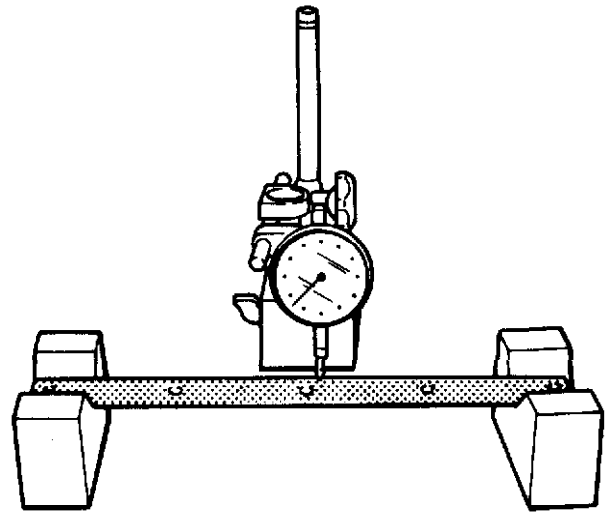
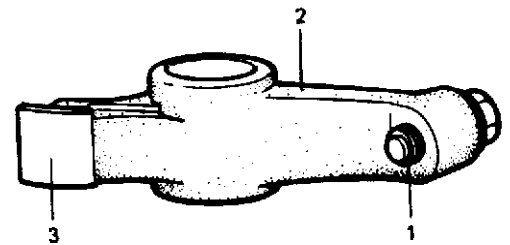


Fig. 3-5-7

- Wear of rocker-arm and adjusting screw:  
If the tip ① of adjusting screw is badly worn, replace screw. Arm must be replaced if its cam-riding face ③ is badly worn.



1. Adjusting screw
2. Rocker arm
3. Cam-riding face

Fig. 3-5-8

### Valve Guides

Using a micrometer and bore gauge, take diameter readings on valve stems and guides to determine stem clearance in guide. Be sure to take a reading at more than one place along the length of each stem and guide.

Item		Standard	Limit
Valve stem diameter	In	6.965 – 6.980 mm (0.2742 – 0.2748 in.)	—
	Ex	6.950–6.965 m m (0.2737 – 0.2742 in.)	—
Valve guide I.D.	In	7.000–7.015 m m (0.2756 – 0.2761 in.)	—
	Ex.	7.000–7.015 m m (0.2756 – 0.2761 in.)	—
Stem-to-guide clearance	In	0.020 – 0.050 mm (0.0008 – 0.0019 in.)	0.07 mm (0.0027 in.)
	Ex	0.035 – 0.065 mm (0.0014 – 0.0025 in.)	0.09 mm (0.0035 in.)

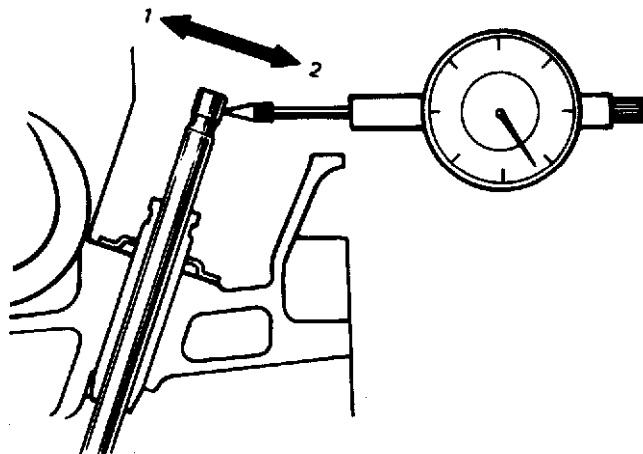


Fig. 3-5-10

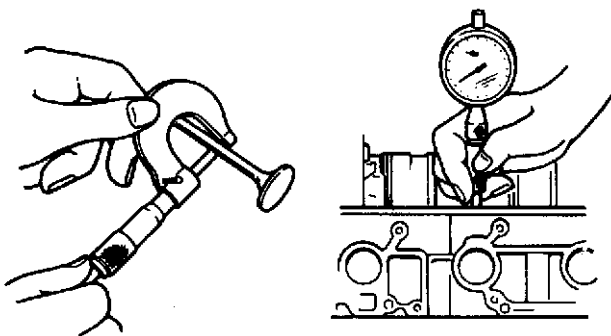


Fig. 3-5-9

If bore gauge is not available, check end deflection of the valve stem in place with a dial gauge rigged.

Move stem end in the directions ① and ② to measure end deflection.

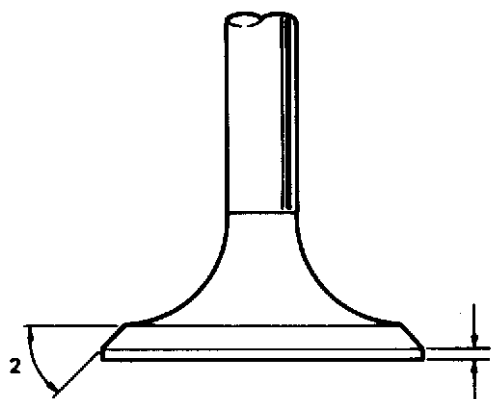
If deflection exceeds its limit, replace valve stem and valve guide.

Valve stem end deflection limit	In	0.14 mm (0.005 in.)
	Ex	0.18 mm (0.007 in.)

### Valves

- Remove all carbon from valves.
- Inspect each valve for wear, burn or distortion at its face and stem and replace as necessary.
- Measure thickness of valve head. If measured thickness exceeds its limit specified below, replace valve.

Valve head thickness		
Standard	Limit	
1.0 mm (0.039 in.)	In	0.6 mm (0.023 in.)
	Ex	0.7 mm (0.027 in.)



1. Valve head thickness
2. 45°

Fig. 3-5-11

- Check end face of each valve stem for wear. This face meets rocker arm intermittently in operation, and might become concaved or otherwise irregular. As necessary, smoothen the end face with an oil stone and, if this grinding removes the end stock by as much as 0.5 mm (0.0196 in.) (as measured from the original face), replace the valve.

Limit on stock allowance of valve stem end face	0.5 mm (0.0196 in.)
---	------------------------

- Check each valve for radial runout with a dial gauge and "V" block. To check runout, rotate valve slowly. If runout exceeds limit, replace valve.

Limit on valve head radial runout	0.08 mm (0.003 in.)
-----------------------------------	---------------------

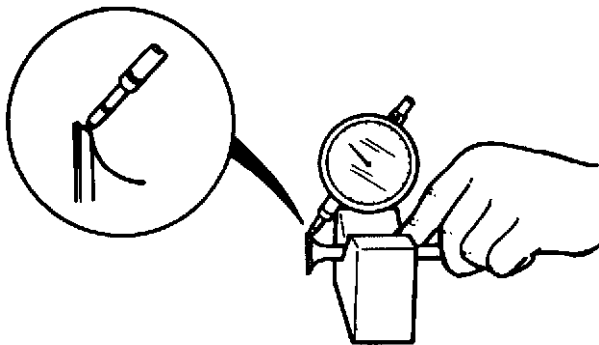


Fig. 3-5-12

#### Valve Seats

**CAUTION :**  
Valves to be checked and serviced for seating width and contact pattern must be those found satisfactory in regard to stem clearance in the guide and also requirements stated on preceding page under valves.

- Seating contact width:  
Produce contact pattern on each valve in the usual manner, namely, by giving uniform coat of marking compound to valve seat and by rotatingly tapping seat with valve head. Valve lapper (tool used in valve lapping) must be used.

The pattern produced on seating face of valve must be a continuous ring without any break, and width  $\text{\textcircled{W}}$  of pattern must be within stated range as follows.

Standard seating width revealed by contact pattern on valve face	Intake	1.3 – 1.5 mm (0.0512 – 0.0590 in.)
	Exhaust	

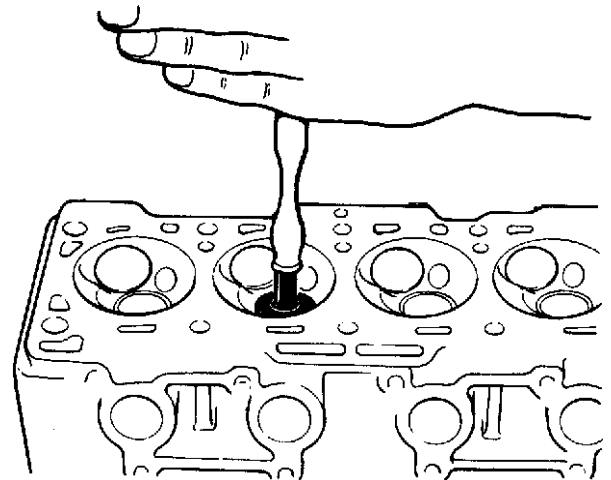
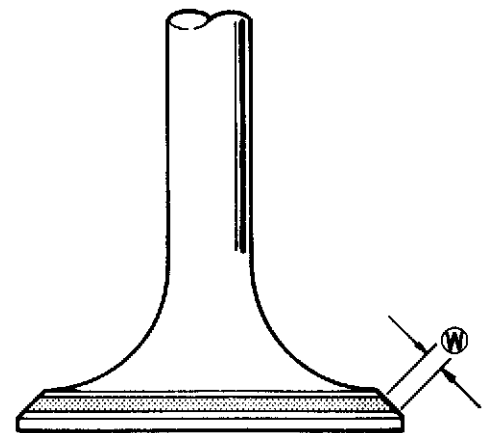


Fig. 3-5-13



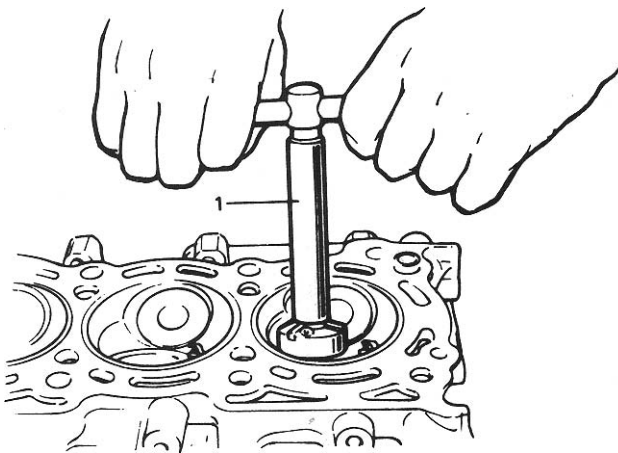
$\text{\textcircled{W}}$  Valve seat contact width

Fig. 3-5-14

- Valve seat repair:  
Valve seat not producing uniform contact with its valve or showing width  $\text{W}$  of seating contact that is off the specified range must be repaired by regrinding or by cutting and regrinding and finished by lapping.

1) EXHAUST VALVE SEAT: Use a valve seat cutter to make three cuts as illustrated in Fig. 3-5-16. Three cutters must be used: the first for making 15° angle, the second for making 75° angle and the last for making 45° seat angle. The third cut must be made to produce desired seat width  $\text{W}$ .

Seat width $\text{W}$ for exhaust valve seat	1.3 – 1.5 mm (0.0512 – 0.0590 in.)
--	---------------------------------------



1. Valve seat cutter

Fig. 3-5- 15 Valve seat cutting

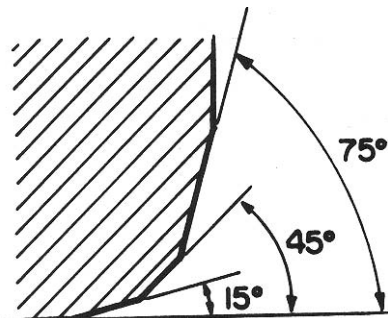


Fig. 3-5- 16 Valve seat angles for exhaust valve

2) INLET VALVE SEAT: Cutting sequence is the same as for exhaust valve seats but the second angle is (60°).

Seat width $\text{W}$ for inlet valve seat	1.3 – 1.5 mm (0.0512 – 0.0590 in.)
--	---------------------------------------

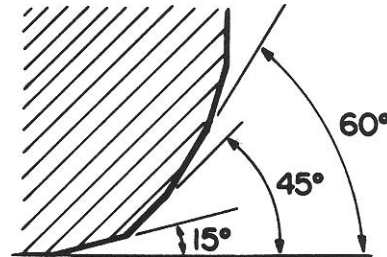


Fig. 3-5- 17 Valve seat angles for in take valve

3) VALVE LAPPING. Lap valve on seat in two steps, first with coarse-size lapping compound applied to its face and the second with a fine-size compound, each time using a valve lapper according to usual lapping method.

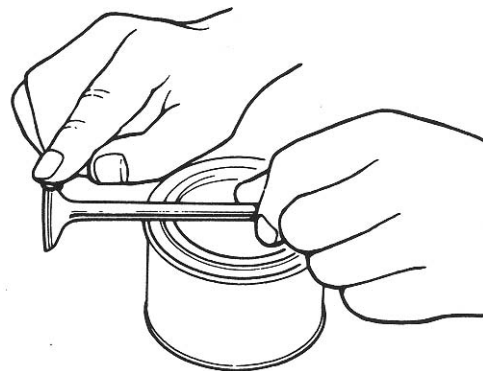


Fig. 3-5- 18 Applying lapping compound to valve face

**NOTE:**

- After lapping, wipe compound off valve face and seat, and produce contact pattern with marking compound. Check to be sure that contact is centered widthwise on valve seat and that there is no break in contact pattern ring.
- Be sure to check and, as necessary, adjust valve clearance after reinstalling cylinder head and valve mechanism.

### Camshaft

- **Runout of camshaft:**  
Hold camshaft between two "V" blocks, and measure runout by using a dial gauge.  
If runout exceeds its limit, replace camshaft.

Runout limit	0.10 mm (0.0039 in.)
--------------	----------------------

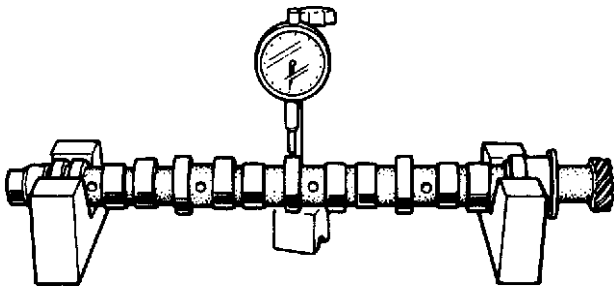


Fig. 3-5-23

- **Cam wear:**  
Using a micrometer, measure height (H) of cam (lobe). If measured height is less than respective limits, replace camshaft.

Cam height	Standard	Limit
Intake cam	37.500 mm (1.4763 in.)	37.400 mm (1.4724 in.)
Exhaust cam	37.500 mm (1.4763 in.)	37.400 mm (1.4724 in.)
Fuel pump drive cam	40.000 mm (1.5748 in.)	39.600 mm (1.5590 in.)

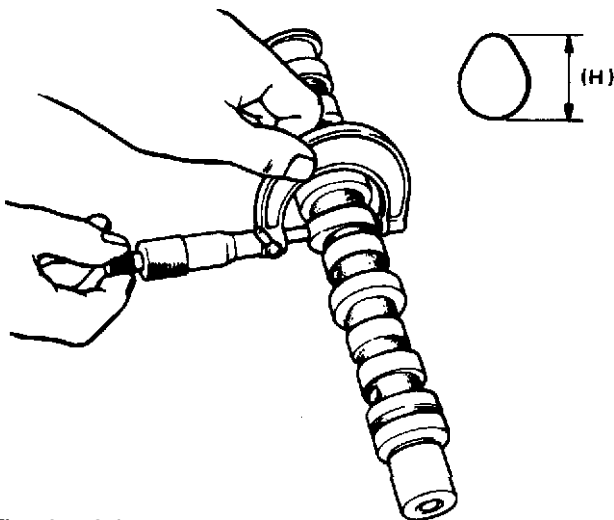


Fig. 3-5-24

- **Journal wear:**  
Measure journal diameter in two directions at two places (total of 4 readings) on each journal as shown in Fig. 3-5-25, and also by using bore gauge, measure journal bore in cylinder head as shown in Fig. 3-5-26 (i.e. 4 readings on each journal).  
Subtract journal diameter measurement from journal bore measurement to determine journal clearance.  
If journal clearance exceeds its limit, replace camshaft, and as necessary, cylinder head, too.

	Standard	
Journal clearance limit	0.050 – 0.091 mm (0.0020 – 0.0036 in.)	0.15 mm (0.0059 in.)

Camshaft journal dia.	Journal bore dia.
Ⓐ 44.125–44.150 mm (1.7372 – 1.7381 in.)	44.200 – 44.216 mm (1.7402 – 1.7407 in.)
Ⓑ 44.325 –44.350 mm (1.7451 – 1.7460 in.)	44.400 –44.416 mm (1.7480 – 1.7486 in.)
Ⓒ 44.525 –44.550 mm (1.7530 – 1.7539 in.)	44.600 –44.616 mm (1.7560 – 1.7565 in.)
Ⓓ 44.725 – 44.750 mm (1.7609 – 1.7618 in.)	44.800 – 44.816 mm (1.7638 – 1.7644 in.)
Ⓔ 44.925 – 44.950 mm (1.7687 – 1.7697 in.)	45.000 – 45.016 mm (1.7716 – 1.7723 in.)

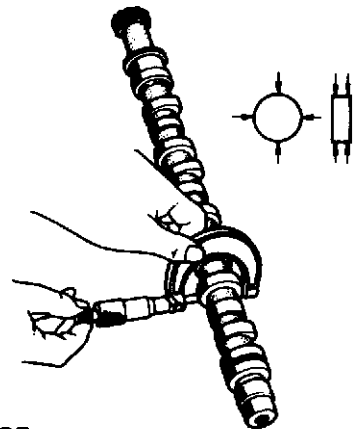
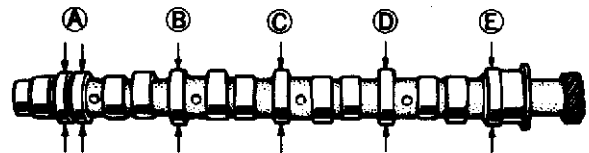


Fig. 3-5-25

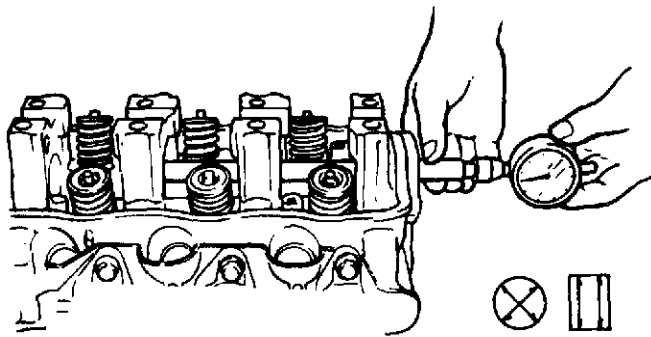


Fig. 3-5-26

### Cylinder Block

- Distortion of gasketed surface:  
Using a straightedge and a thickness gauge, check gasketed surface for distortion and, if result exceeds specified limit, correct it.

	Standard	Limit
Flatness	0.03 mm (0.0012 in.)	0.06 mm (0.0024 in.)

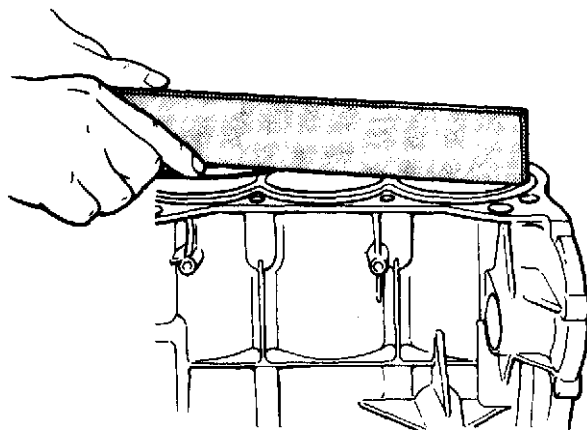


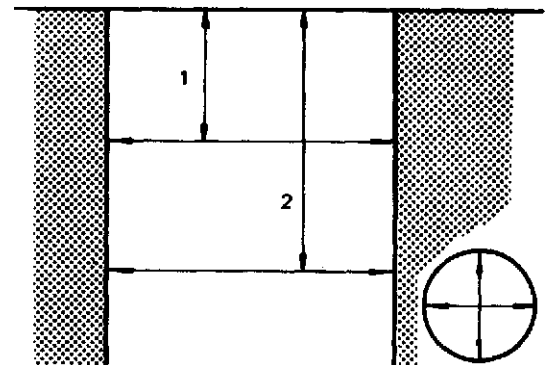
Fig. 3-5-27

- Cylinder bore:
  - 1) Inspect cylinder walls for scratches, roughness, or ridges which indicate excessive wear. If cylinder bore is very rough or deeply scratched, or ridged, rebore cylinder and use oversize piston.
  - 2) Using a cylinder gauge, measure cylinder bore in thrust and axial directions at two positions as shown in Fig. 3-5-28.  
If any of the following conditions exists, rebore cylinder.
    - Cylinder bore dia. exceeds its limit.
    - Difference of measurements at two positions exceeds taper limit.
    - Difference between thrust and axial measurements exceeds out-of-round limit.

Cylinder bore dia. limit	74.15 mm (2.9193 in.)
Taper and out-of-round limit	0.10 mm (0.0039 in.)

### NOTE:

If any one of four cylinders has to be rebored, rebore all four to the same next oversize. This is necessary for the sake of uniformity and balance.



1. 50mm (1.96 in.)
2. 95 mm (3.74 in.)

Fig. 3-5-28 Positions to be measured

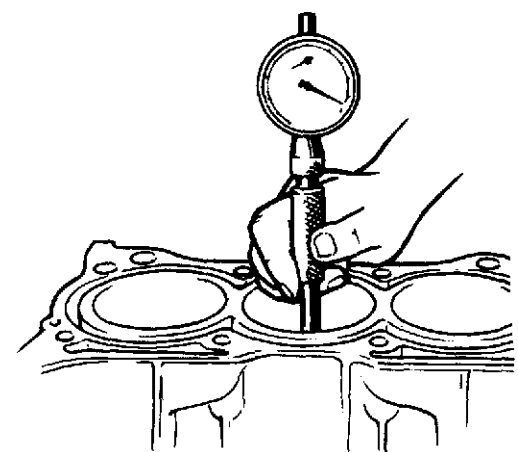


Fig. 3-5-29 Measuring cylinder bore with cylinder gauge



● Honing or reboring cylinders:

- 1) When any cylinder needs reboring, all other cylinders must also be rebored at same time.
- 2) Select oversized piston according to amount of cylinder wear.

Size	Piston diameter
O/S 0.25	74.220–74.230 mm (2.9220 – 2.9224 in.)
o/s 0.50	74.470–74.480 mm (2.9318 – 2.9322 in.)

- 3) Using micrometer, measure piston diameter.

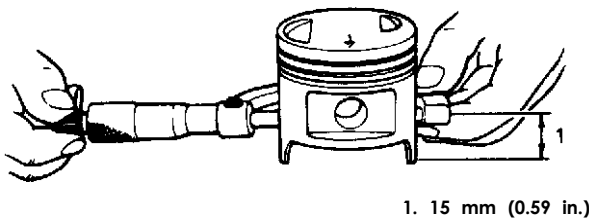


Fig. 3-5-30 Measuring piston diameter

- 4) Calculate cylinder bore diameter to be rebored.

$$D = A + B - C$$

D : Cylinder bore diameter to be rebored.

A : Piston diameter as measured.

B : Piston clearance = 0.02 – 0.04 mm  
(0.0008 – 0.0015 in)

C : Allowance for honing = 0.02 mm  
( 0 . 0 0 0 8 i n )

- 5) Rebore and hone cylinder to calculated dimension.

**NOTE:**

Before reboring, install all main bearing caps in place and tighten to specification to avoid distortion of bearing bores.

- 6) Measure piston clearance after honing.

**Piston and Piston Rings**

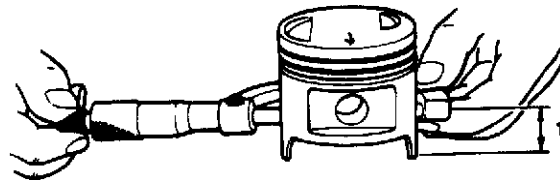
Clean carbon from piston head and ring grooves, using a suitable tool.

Inspect piston for faults, cracks or other damage. Damaged or faulty piston should be replaced.

● Piston diameter:

As indicated in Fig. 3-5-31, piston diameter should be measured at the height of 15 mm (0.59 in) from piston skirt end in the direction perpendicular to piston pin.

Piston diameter	Standard	73.970 – 73.990 mm (2.9122 – 2.9129 in.)
	Oversize: 0.25 mm (0.0098 in.)	74.220–74.230 mm (2.9220 – 2.9224 in.)
	0.50 mm (0.0196 in.)	74.47 – 74.48 mm (2.9319 – 2.9322 in.)



1.15 mm (0.59 in)

Fig. 3-5-31 Measuring piston diameter with micrometer

● Piston clearance:

To calculate piston clearance, measure cylinder bore diameter and piston diameter. The piston clearance is difference between cylinder bore diameter and piston diameter. Piston clearance should be within specification as follows.

If it is out of specification, rebore cylinder and use oversize piston.

Piston clearance	0.02 – 0.04 mm (0.0008 – 0.0015 in.)
------------------	---

**NOTE:**

Cylinder bore diameters measured in thrust direction at two positions as shown in Fig. 3-5-28 should be used for calculation of piston clearance.

- **Ring groove clearance:**  
Before checking, piston grooves must be clean, dry and free from carbon.  
Fit new piston ring into piston groove, and measure clearance between ring and ring land by using thickness gauge.  
If the clearance is out of specification, replace piston.

Ring groove clearance	Top	0.03 – 0.07 mm (0.0012 – 0.0027 in.)
	2nd	0.02 – 0.06 mm (0.0008 – 0.0023 in.)

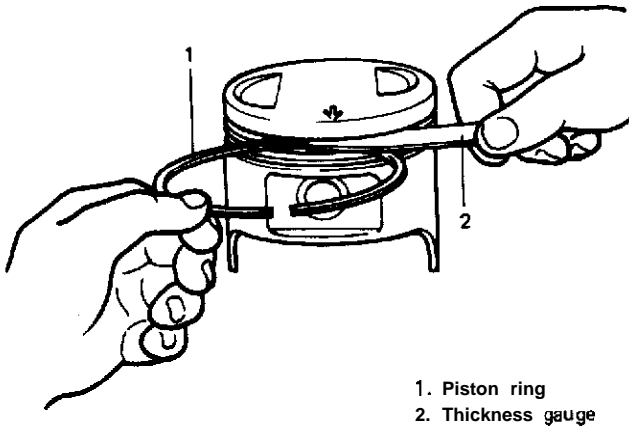


Fig. 3-5-32 Measuring ring groove clearance

- **Piston ring end gap:**  
To measure end gap, insert piston ring into cylinder bore, locating it at the lowest part of bore and holding it true and square; then use a feeler gauge to measure gap. If the gap exceeds its limit, replace ring.

**NOTE:**

Decarbon and clean top of cylinder bore, before inserting piston ring.

Item		Standard	Limit
Piston ring end gap	Top ring	0.20–0.33 mm (0.0079 – 0.0129 in.)	0.7 mm (0.0275 in.)
	2nd ring	0.20 – 0.35 mm (0.0079 – 0.0137 in.)	0.7 mm (0.0275 in.)
	Oil ring	0.20 – 0.70 mm (0.0079 – 0.0275 in.)	1.8 mm (0.0708 in.)

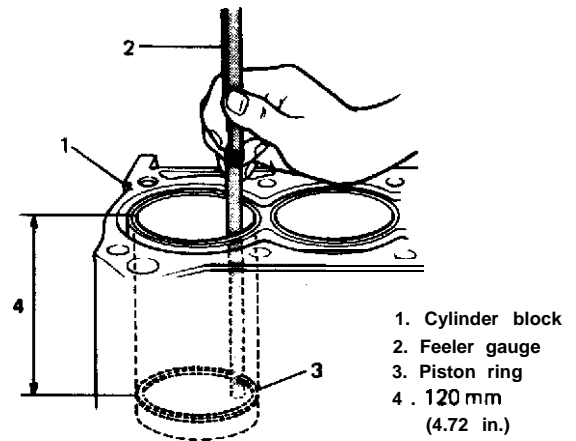


Fig. 3-5-33 Measuring piston ring end gap

**Piston Pins**

- Piston pin must be fitted into piston bore with an easy finger push at normal room temperature.
- Check piston pin and piston bore for wear or damage. If pin or piston bore is badly worn or damaged, replace pin or piston, or both.

**Connecting Rods**

- **Big-end side clearance:**  
Check big end of connecting rod for side clearance, with rod fitted and connected to its crank pin in the normal manner. If clearance measured is found to exceed its limit, replace connecting rod.

Item	Standard	Limit
Big-end side clearance	0.10 – 0.20 mm (0.0039 – 0.0078 in.)	0.35 mm (0.0137 in.)

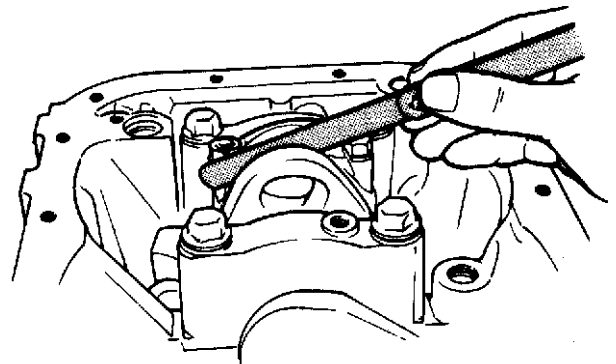


Fig. 3-5-34 Measuring side clearance

- **Connecting rod alignment:**  
Mount connecting rod on aligner to check it for bow and twist and, if either limit is exceeded, replace it.

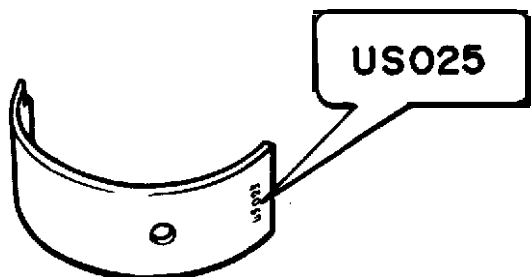
Limit on bow	0.05 mm (0.0020 in.)
Limit on twist	0.10 mm (0.0039 in.)

**Crank Pin and Connecting Rod Bearings**

- **Inspect crank pin for uneven wear or damage.**  
Measure crank pin for out-of-round or taper with a micrometer. If crank pin is damaged, or out-of-round or taper is out of limit, replace crankshaft or regrind crank pin to undersize and use undersize bearing.

Connecting rod bearing size	Crank pin diameter
Standard	41.982 – 42.000 mm (1.6529 – 1.6535 in.)
0.25 mm (0.0098 in.) undersize	41.732 – 41.750 mm (1.6430 – 1.6437 in.)
Out-of-round and taper limit	0.01 mm (0.0004 in.)

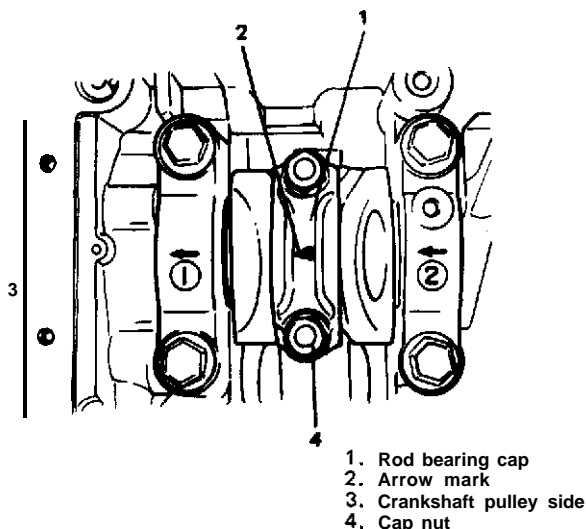
- **Rod bearing:**  
Inspect bearing shells for signs of fusion, pitting, burn or flaking and observe contact pattern. Bearing shells found in defective condition must be replaced.  
Two kinds of rod bearing are available; standard size bearing and 0.25 mm undersize bearing. To distinguish them, 0.25 mm undersize bearing has stamped number (US025) on its backside as indicated in Fig. 3-5-35, but standard size one has no such number.



*Fig. 3-5-35 0.25 mm undersize bearing*

- **Rod bearing clearance :**
  - 1) Before checking bearing clearance, clean bearing and crank pin.
  - 2) Install bearing in connecting rod and bearing cap.
  - 3) Place a piece of gaging plastic the full width of the crankpin as contacted by bearing (parallel to the crankshaft), avoiding the oil hole.
  - 4) Install rod bearing cap to connecting rod. When installing cap, be sure to point arrow mark on cap to crankshaft pulley side, as indicated in Fig. 3-5-36. Tighten the cap nuts to the specified torque, **DO NOT** turn crankshaft with gaging plastic installed.

Tightening torque for rod bearing cap nuts	33 – 37 N·m 3.3 – 3.7 kg·m 24.0 – 26.5 lb·ft
--	--



*' Fig. 3-5-36 Installing bearing cap*

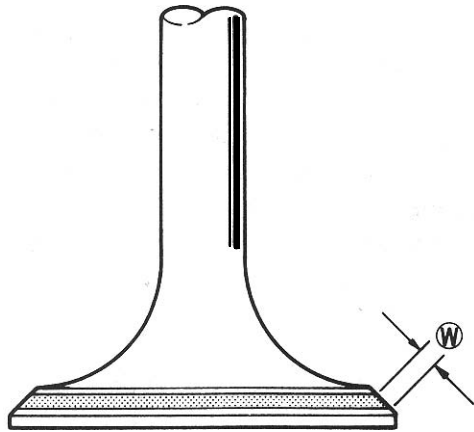


Fig. 3-5-19 Contactpattern  $\text{\textcircled{W}}$  uniform in width

### Valve Springs

- Referring to the criterion-data given below, check to be sure that each spring is in sound condition, free of any evidence of breakage or weakening. Remember, weakened valve springs can be the cause of chatter, not to mention the possibility of reducing power output due to gas leakage caused by decreased seating pressure.

Item	Standard	Limit
Valve spring free length	49.3 mm (1.9409 in.)	48.1 mm (1.8937 in.)
Valve spring preload	24.8 – 29.2 kg for 41.5 mm (54.7 – 64.3 lb/ 1.63 in.)	22.8 kg for 41.5 mm (50.2 lb/ 1.63 in.)

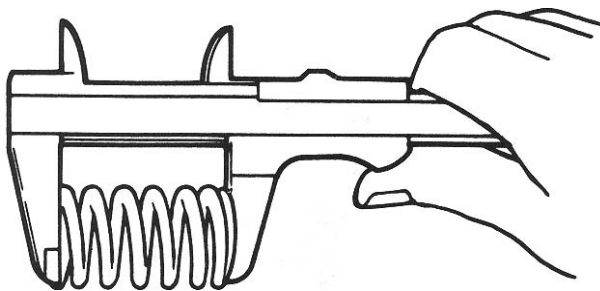


Fig. 3-5-20 Measuring free length of spring

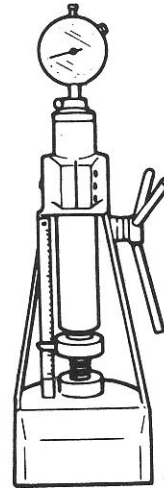


Fig. 3-5-21 Measuring spring preload

- Spring squareness:  
Use a square and surface plate to check each spring for squareness in terms of clearance between the end of valve spring and square. Valve springs found to exhibit a larger clearance than specified limit must be replaced.

---

Valve springs squareness limit	2.0 mm (0.079 in.)
--------------------------------	--------------------

---

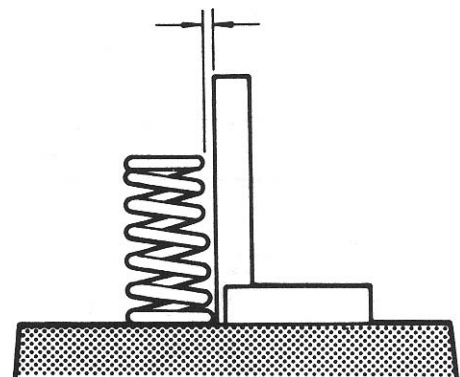


Fig. 3-5-22 Measuring spring squareness

- 5) Remove cap and using scale on gaging plastic envelope, measure gaging plastic width at the widest point.  
If the clearance exceeds its limit, use a new standard size bearing and remeasure clearance.

	Standard	Limit
Bearing clearance	0.030 – 0.050 mm (0.0012 – 0.0019 in.)	0.080 mm (0.0031 in.)

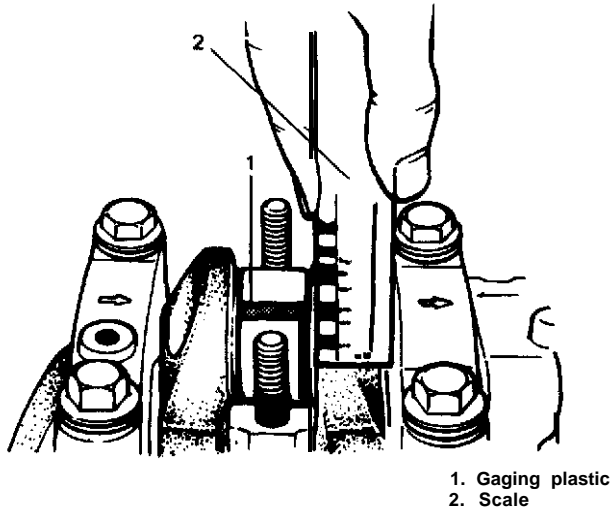


Fig. 3-5-37 Measuring rod bearing clearance

- 6) If clearance can not be brought to within limit even by using a new standard size bearing, regrind crankpin to the undersize and use 0.25 mm undersize bearing.

#### Crankshaft

- Crankshaft runout:  
Using a dial gauge, measure runout at center journal. Rotate crankshaft slowly. If runout exceeds limit, replace crankshaft.

Limit on runout	0.06mm (0.0023 in.)
-----------------	---------------------

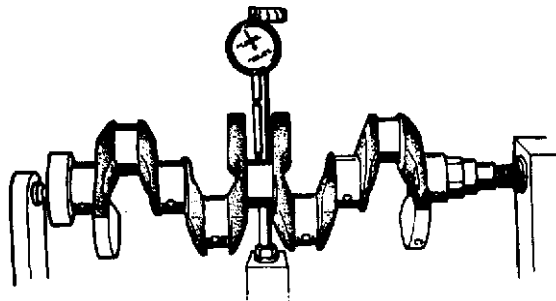


Fig3-5-38 Measuring runout

- Crankshaft thrust play :  
Measure this play with crankshaft set in cylinder block in the normal manner, that is, with thrust bearing fitted and journal bearing caps installed. Tighten bearing cap bolts to specified torque.  
Use a dial gauge to read displacement in axial (thrust) direction of crankshaft.  
If the limit is exceeded, replace thrust bearing with new standard one or oversize one to obtain standard thrust play.

Tightening torque for main bearing cap bolts	50 – 57 N·m 5.0 – 5.7 kg·m 36.5 – 41.0 lb·ft
--	--

Item	Standard	Limit
Crankshaft thrust play	0.11 – 0.31 mm (0.0044– 0.0122 in.)	0.38mm (0.0149 in.)

Thickness of crankshaft thrust bearing	Standard	2.50 mm (0.0984 in.)
	Oversize	2.563 mm (0.1009 in.)

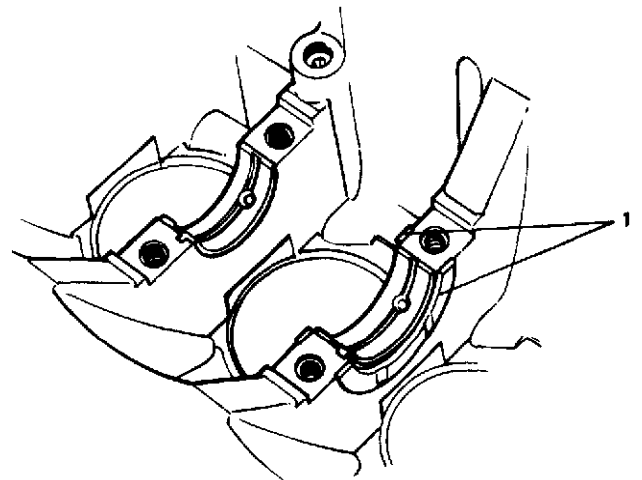


Fig. 3-5-39 Thrust bearings

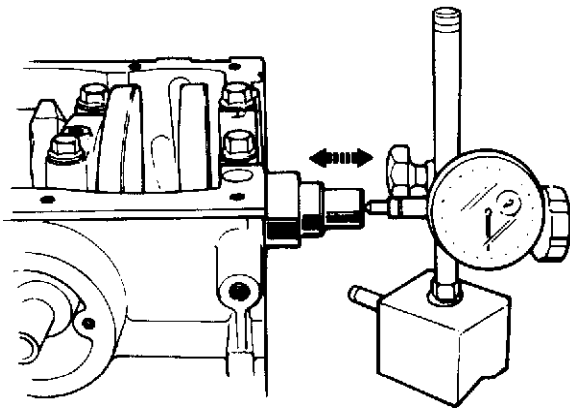


Fig. 3-5-40 Measuring thrust play of crankshaft

- **Out-of-round and taper (uneven wear):**  
An unevenly worn crankshaft journal shows up as a difference in diameter at a cross section or along its length (or both). This difference, if any, is to be determined from micrometer readings.  
If any of journals is badly damaged or if the amount of uneven wear in the sense explained above exceeds its limit, regrind or replace the crankshaft.

Limit on out-of-round and taper	0.01 mm (0.0004 in.)
---------------------------------	----------------------

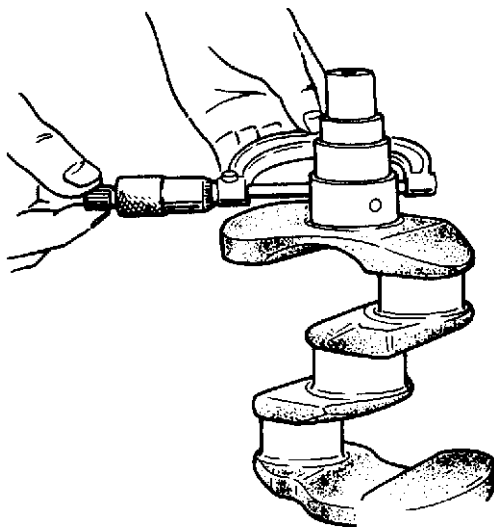


Fig. 3-5-41 Checking uneven wear

## Crankshaft Main (Journal) Bearings

### General informations:

- Service main bearings are available in standard-size and 0.25 mm (0.0098 in) undersize, and each of them has 5 kinds of bearings differing in tolerance.
- The upper half of bearing has oil groove as indicated in Fig. 3-5-42. Install this half with oil groove to cylinder block.

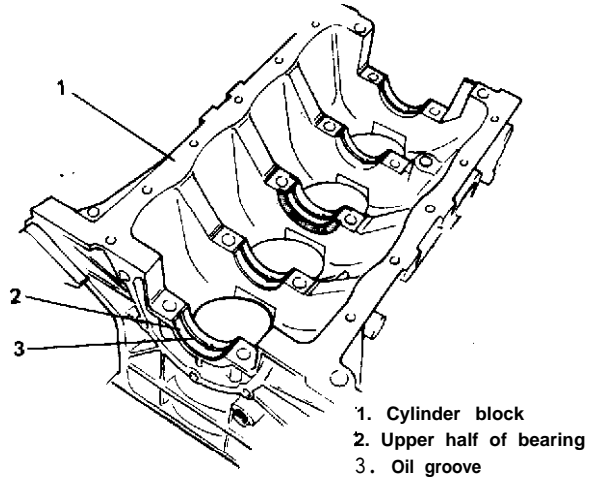


Fig. 3-5-42 Upper half of bearing installation

- On each main bearing cap, arrow mark and number are embossed as indicated in Fig. 3-5-43.

When installing each bearing cap to cylinder block, point arrow mark toward crankshaft pulley side and install each cap from crankshaft pulley side to flywheel side in ascending order of numbers ①, ②, ③, ④ and ⑤. Tighten cap bolts to specified torque.

Tightening torque for main bearing cap bolt	50 – 57 N·m 5.0 – 5.7 kg·m 36.5 – 41.0 lb·ft
---	--

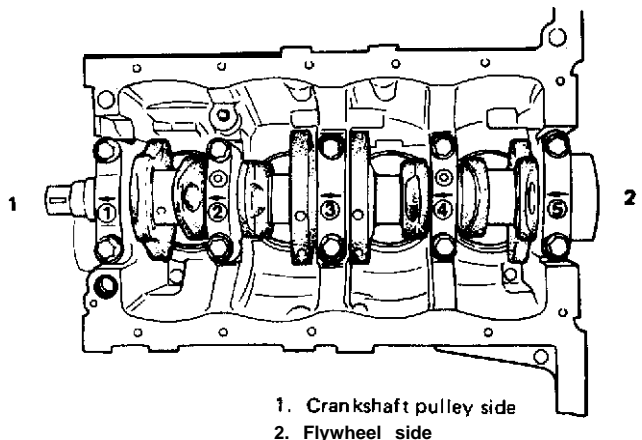


Fig. 3-5-43 Bearing caps installation

inspect:

Check bearings for pitting, scratches, wear or damage. If any malcondition is found, replace both upper and lower halves. Never replace one half without replacing the other half.

Main bearing clearance:

Check clearance by using gaging plastic according to following procedure.

- 1) Remove bearing caps.
- 2) Clean bearings and main journals.
- 3) Place a piece of gaging plastic the full width of the bearing (parallel to the crankshaft) on journal, avoiding oil hole.
- 4) Install bearing cap as previously outlined and evenly torque cap bolts to specified torque. Bearing cap **MUST** be torqued to specification in order to assure proper reading.

**NOTE:**

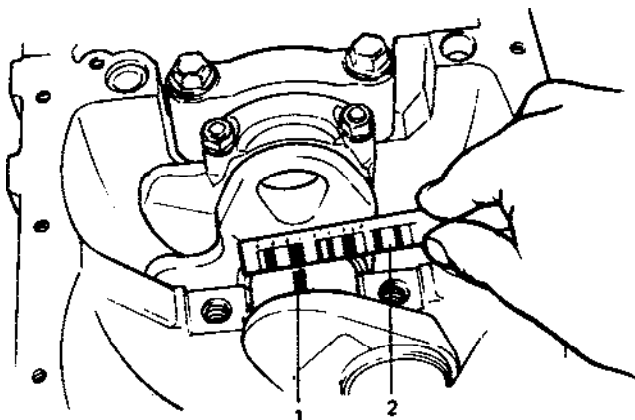
Do not rotate crankshaft while gaging plastic is installed.

- 5) Remove cap, and using scale on gaging plastic envelop, measure gaging plastic width at its Widest point. If clearance exceeds its limit, replace bearing. Always replace both upper and lower inserts as a unit.

A new standard bearing may produce proper clearance. If not, it will be necessary to regrind crankshaft journal for use of 0.25 mm undersize bearing.

After selecting new bearing, recheck clearance.

	Standard	Limit
Bearing clearance	0.020 – 0.040 mm (0.0008 – 0.0016 in.)	0.060 mm (0.0023 in.)



1. Gaging plastic
2. Scale

**Fig. 3-5-44** Measuring main bearing clearance

Selection of main bearings:

**STANDARD BEARING:**

If bearing is in malcondition, or bearing clearance is out of specification, select a new standard bearing according to the following procedure and install it.

- 1) First check journal diameter as follows.

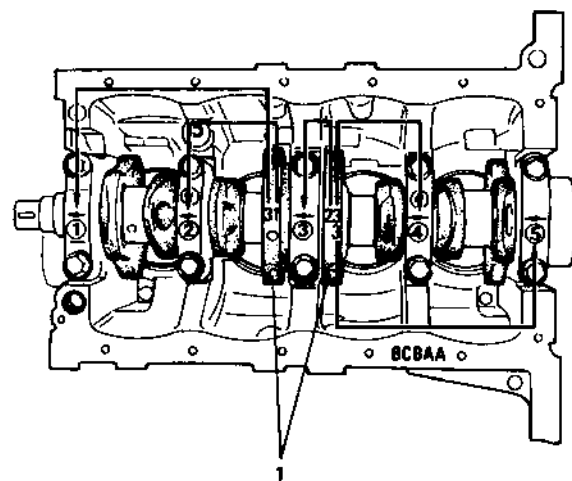
As shown in Fig. 3-5-45, crank webs of No. 2 and No. 3 cylinders have five stamped numerals.

Three kinds of numerals (1, 2 and 3) represent following journal diameters respectively.

Numeral stamped	Journal diameter
1	44.994 – 45.000 mm (1.7714 – 1.7716 in.)
2	44.988 – 44.994 mm (1.7712 – 1.7714 in.)
3	44.982 – 44.988 mm (1.7710 – 1.7712 in.)

The first, second, third, fourth and fifth (left to right) stamped numerals indicate the journal diameters at bearing caps "1", "2", "3", "4" and "5" respectively.

For example, in Fig. 3-5-45, the first (leftmost) numeral "3" indicates that journal dia. at bearing cap ① is within 44.982 – 44.988 mm, and second one "1" indicates that journal dia. at cap ② is within 44.994 – 45.000 mm.



1. Crank webs of No. 2 and 3 cylinder

**Fig. 3-5-45** Stamped numerals on crank webs of No. 2 and No. 3 cylinders

2) Next, check bearing cap bore diameter without bearing.

On mating surface of cylinder block, five alphabets are stamped as shown in Fig. 3-5-46.

Three kinds of alphabets (“A”, “B” and “C”) represent following cap bore diameters.

Alphabet stamped	Bearing cap bore diameter (without bearing)
A	49.000 – 49.006 mm (1.9292 – 1.9294 in.)
B	49.006 – 49.012 mm (1.9294 – 1.9296 in.)
C	49.012 – 49.018 mm (1.9296 – 1.9298 in.)

The first, second, third, fourth and fifth (left to right) stamped alphabets indicate the cap bore diameter of bearing caps “1”, “2”, “3”, “4” and “5” respectively.

For example, in Fig. 3-5-46, the first (leftmost) alphabet “B” indicates that the cap bore dia. of bearing cap ① is within 49.006 – 49.012 mm, and the fifth (rightmost) alphabet “A” indicates that the cap bore dia. of cap ⑤ is within 49.000 – 49.006 mm.

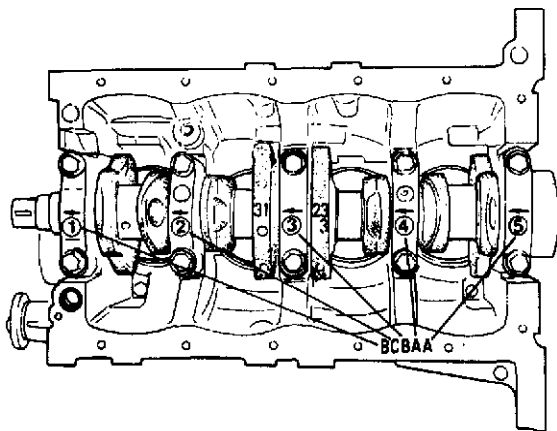
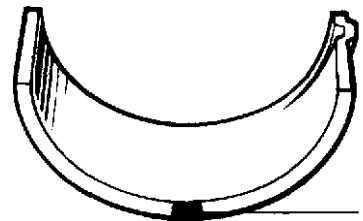


Fig. 3-5-46 Stamped alphabets on cylinder block

3) There are five kinds of standard bearings differing in thickness. To distinguish them, they are painted in following colors at the position indicated in Fig. 3-5-47.

Each color indicates the following thicknesses at center of bearing.

Color painted	Bearing thickness
Green	1.996 – 2.000 mm (0.0786 – 0.0787 in.)
Black	1.999 – 2.003 mm (0.0787 – 0.0788 in.)
Colorless (no paint)	2.002 – 2.006 mm (0.0788 – 0.0789 in.)
Yellow	2.005 – 2.009 mm (0.0789 – 0.0790 in.)
Blue	2.008 – 2.012 mm (0.0790 – 0.0791 in.)



1. Paint

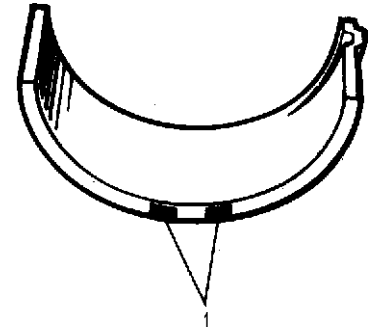
Fig. 3-5-47 Paint on standard bearing

4) From the numeral stamped on crank webs of No. 2 and No. 3 cylinders and the alphabets stamped on mating surface of cylinder block, determine new standard bearing to be installed to the journal, by referring to the table shown below.

For example, if numeral stamped on crank web is “1” and alphabet stamped on mating surface is “B”, install new standard bearing painted in “Black” to its journal.



		Numerals stamped on crank webs (Journals diameter)		
		1	2	3
Alphabets stamped on mating surface	A	Green	Black	Colorless
	B	Black	Colorless	Yellow
	c	Colorless	Yellow	Blue
New standard bearing to be installed.				



1. Paint

Fig. 3-5-48 Faints on undersize bearing

- 5) Using gaging plastic, check bearing clearance with new standard bearing selected. If clearance still exceeds its limit, use next thicker bearing and recheck clearance.
- 6) When replacing crankshaft or cylinder block due to any reason, select new standard bearings to be installed by referring to the numerals stamped on new crankshaft or the alphabets stamped on the mating surface of new cylinder block.

**UNDERSIZE BEARING (0.25 mm):**

- 0.25 mm undersize bearing is available in 5 kinds differing in thickness. To distinguish them, each bearing is painted in following colors at position indicated in Fig. 3-5-48. Each color indicates following thickness at center of bearing.

Color painted	Bearing thickness
Green & Red	2.121 – 2.125 mm (0.0835 – 0.0836 in.)
Black & Red	2.124 – 2.128 mm (0.0836 – 0.0837 in.)
Red only	2.127 – 2.131 mm (0.0837 – 0.0838 in.)
Yellow & Red	2.130 – 2.134 mm (0.0838 – 0.0839 in.)
Blue & Red	2.133 – 2.137 mm (0.0839 – 0.0840 in.)

- If crankshaft journal is necessary to be reground to undersize, regrind the journal and select undersize bearing to be used as follows.

- 1) Regrind journal to following finished diameter.

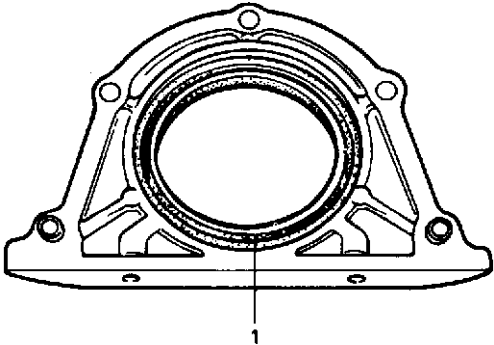
Finished diameter	44.732 -44.750 mm (1.7612 – 1.7618 in.)
-------------------	--

- 2) Using micrometer, measure reground journal diameter. Measurement should be carried out in two directions perpendicular to each other in order to check for out-of-round.
- 3) From the journal diameter measured above and the alphabets stamped on mating surface of cylinder block, select the undersize bearing to be installed by referring to the table shown below. Check bearing clearance with undersize bearing selected.

		Measured journal diameter		
		44.744 – 44.750 mm (1.7616 – 1.7618 in.)	44.738 – 44.744 mm (1.7614 – 1.7616 in.)	44.732 – 44.738 mm (1.7612 – 1.7614 in.)
Alphabets stamped on mating surface of cylinder block	A	Green & Red	Black & Red	Red only
	B	Black & Red	Red only	Yellow & Red
	C	Red only	Yellow & Red	Blue & Red
Undersize bearing to be installed.				

### Rear Oil Seal

Carefully inspect oil seal for wear or damage. If its lip is worn or damaged, replace oil seal.



1. Rear oil seal

Fig. 3-5-49 Rear oil seal

### Flywheel

- If ring gear is damaged, cracked or worn, replace flywheel.
- If surface contacting clutch disc is damaged, or excessively worn, replace flywheel.
- Check flywheel for face runout with a dial gauge.  
If runout is out of limit, replace flywheel.

Limit on runout	0.2 mm (0.0078 in.)
-----------------	---------------------

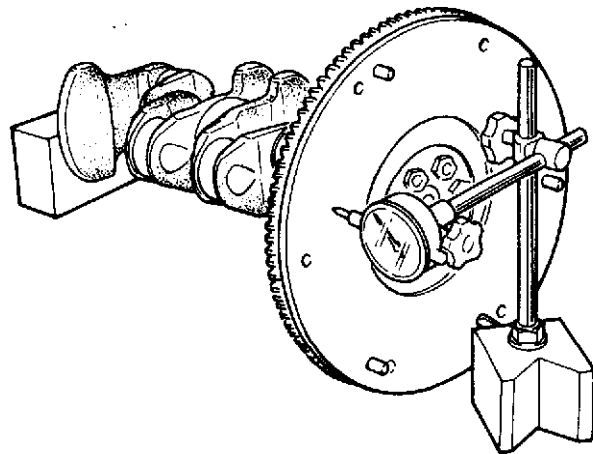


Fig. 3-5-50 Measuring runout

### Oil Pump

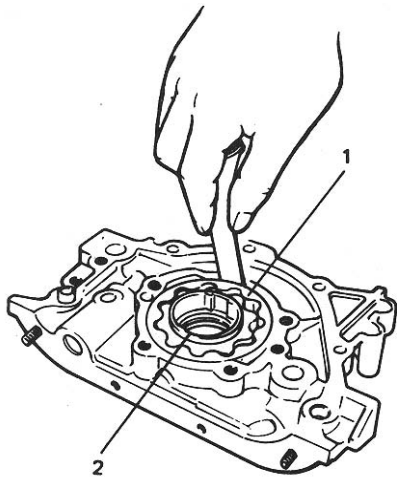
- 1) Inspect oil seal lip for fault or other damage. Replace as necessary.
  - 2) Inspect outer and inner rotors, rotor plate, and oil pump case for excessive wear or damage.
- Radial clearance:  
Check radial clearance between outer rotor and case, using thickness gauge.  
If clearance exceeds its limit, replace outer rotor or case.

Radial clearance between:	Limit on radial clearance
Outer rotor and case	0.310 mm (0.0122 in.)

### 3-6. ENGINE REASSEMBLY

#### NOTE:

- All parts to be used in reassembly must be perfectly clean.
- Oil sliding and rubbing surfaces of engine parts just before using them in reassembly. Use engine oil (Refer to page I-8).
- Have liquid packing ready for use. SUZUKI BOND NO. 1215 is specified for it. Use it wherever its use is specified in order to ensure leak-free (oil and water) workmanship of reassembly.
- There are many running clearances. During the course of engine reassembly, be sure to check these clearances, one after another, as they form.
- Gaskets, "O" rings and similar sealing members must be in perfect condition. For these members, use replacement parts in stock.
- Tightening torque is specified for important fasteners – mainly bolts and nuts -of the engine and other components. Use torque wrenches and constantly refer to the specified values given on p. 3-58.
- Do not disregard match marks provided on parts. Some of them are those given at the time of disassembly.
- There are many sets of parts. Crankshaft bearings, connecting rods, pistons, etc., are in combination sets. Do not disturb such combinations and make sure that each part goes back to where it came from.

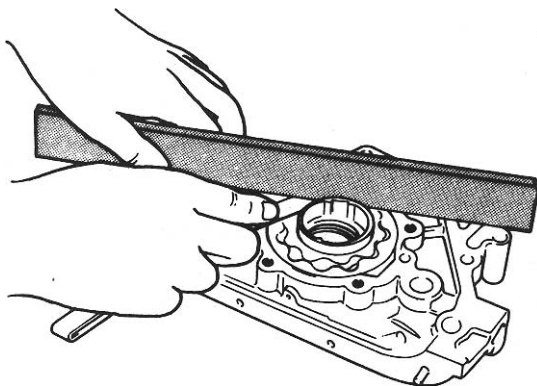


1. Outer rotor  
2. Inner rotor

**Fig. 3-5-51 Radial clearances**

- Side clearance:  
Using straight edge and thickness gauge, measure side clearance.

Limit on side clearance	0.15 mm (0.0059 in.)
-------------------------	----------------------



**Fig. 3-5-52 Side clearance measurement**

#### Timing Belt end Tensioner

- Inspect timing belt for wear or crack. Replace it as necessary.
- Inspect tensioner for smooth rotation.

Engine reassembly is the reverse of engine disassembly as far as sequence is concerned, but there are many reassembling steps that involve measures necessary for restoring engine as close to factory-assembled condition as possible. Only those steps will be dealt with here.

## Crankshaft

1) Install main bearings to cylinder block.

### NOTE:

If main bearing replacement is necessary, select such bearing as to allow proper clearance as described on p. 3-30 and install it in place.

Between two halves of main bearing, one side has oil groove. Install this half with oil groove to cylinder block, and another half without oil groove to bearing cap.

Make sure that two halves are painted with same color.

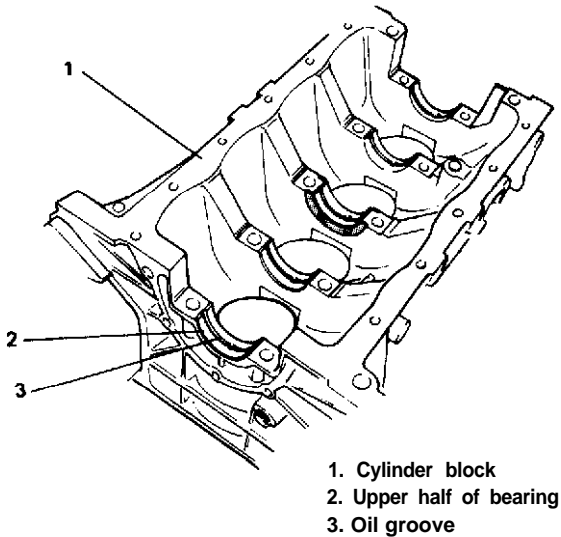


Fig. 3-6-1 Installing bearing half with oil groove

2) Be sure to oil crankshaft journal bearings as shown.

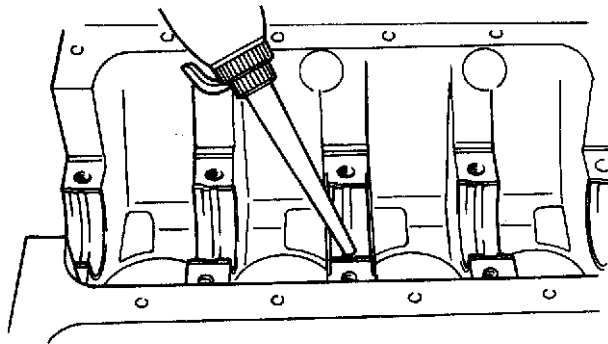


Fig. 3-6-2

3) Install thrust bearings to cylinder block between No. 2 and No. 3 cylinders. Face oil groove sides to crank webs.

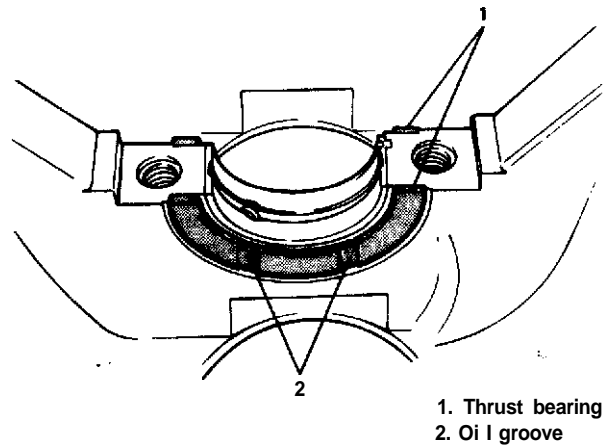


Fig. 3-6-3 Installing thrust bearing

4) Install crankshaft to cylinder block.

5) Oil crankshaft journals.

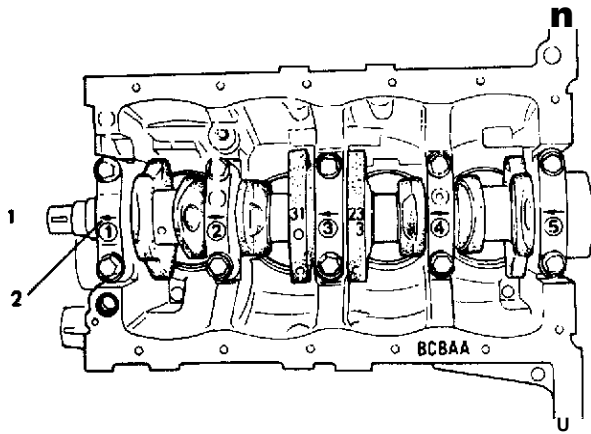
6) When fitting bearing caps to journals after setting crankshaft in place, be sure to point arrow mark (on each cap) to crankshaft pulley side. Fit them sequentially in ascending order, 1, 2, 3, 4 and 5, starting from pulley side.

Tightening torque for main bearing cap bolts	50 – 57 N·m 5.0 – 5.7 kg·m 36.5 – 41.0 lb·ft
--	--

Gradual and uniform tightening is important for bearing cap bolts. Make sure that five caps become tight equally and uniformly specified torque.

### NOTE:

After tightening cap bolts, check to be sure that crankshaft rotates smoothly when turned by hand.



1. Crankshaft pulley side  
2. Arrow mark

**Fig. 3-6-4 Installing main bearing caps**

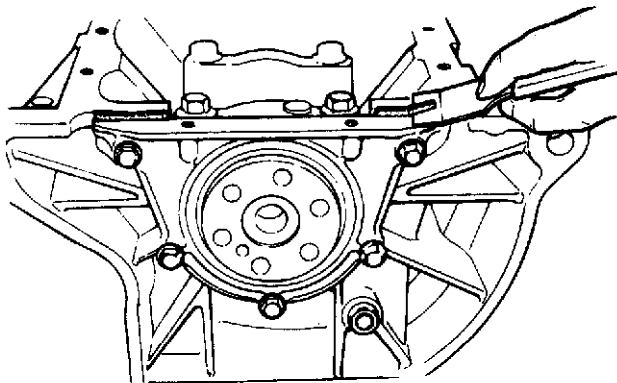
### Oil Seal Housing

Install oil seal housing and its gasket.

Install new gasket. Do not reuse gasket removed in disassembly. Apply oil to oil seal lip before installing. Tighten housing bolts to specification.

After installing oil seal housing, gasket edges might bulge out; if so, cut off edges to flush with cylinder block and oil seal housing.

Tightening torque for housing bolts	10 – 13 N·m
	1.0 – 1.3 kg·m
	7.5 – 9.0 lb·ft



**Fig. 3-6-5 Cutting off edges of gasket**

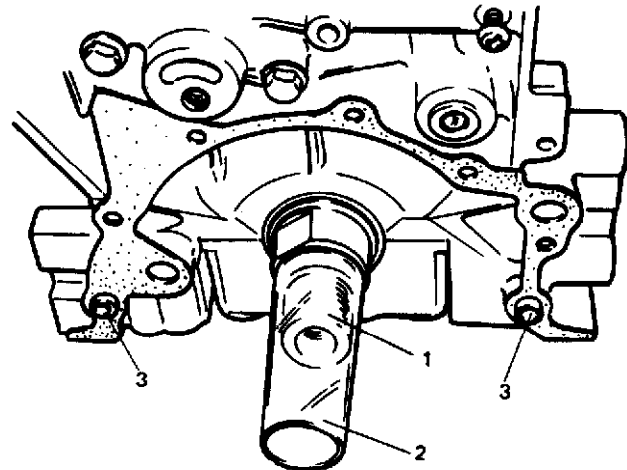
### Oil Pump

#### NOTE:

Reassemble components of oil pump assembly according to following procedure, if disassembled.

- Wash, clean and then dry all disassembled parts.
- Apply thin coat of engine oil to inner and outer rotors, oil seal lip portion, and inside surfaces of oil pump case and plate.
- Install outer and inner rotors to pump case.
- Install gear plate. Tighten 5 screws securely.
- After installing plate, check to be sure that gears turn smoothly by hand.

- Install two oil pump pins and oil pump gasket to cylinder block. Use new gasket.
- To prevent oil seal lip from being damaged or upturned when installing oil pump to crankshaft, fit oil seal guide (special tool) to crankshaft, and apply engine oil to it.



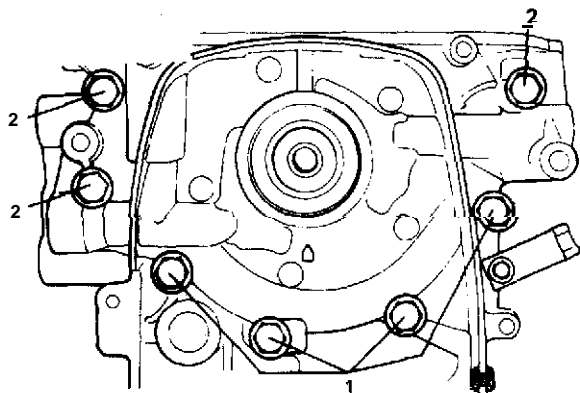
1. Crankshaft  
2. Oil seal guide (Vinyl resin) (Special tool 09926-18210)  
3. Oil pump pin

**Fig. 3-6-6 Special tool (Oil seal guide) installation**

3) Install oil pump to crankshaft and cylinder block. install No. 1 and No. 2 bolts as shown in Fig. 3-6-7, and tighten them to specified torque.

After installing oil pump, check to be sure that oil seal lip is not upturned, and then remove special tool.

Tightening torque for No. 1 and No. 2 bolts	9 – 12 N·m 0.9 – 1.2 kg·m 7.0 – 8.5 lb·ft
---	---



1. No. 1 bolts (short)  
2. No. 2 bolts (long)

Fig. 3-6-7

4) Edge of oil pump gasket might bulge out: if it does, cut bulge off with a sharp knife, making edge smooth and flush with end faces of the pump case and cylinder block.

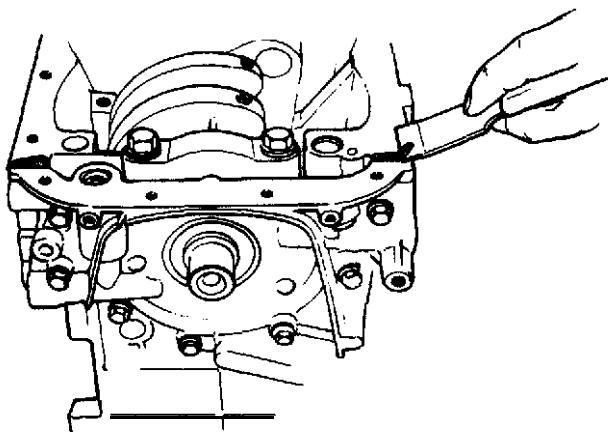


Fig. 3-6-8 Cutting the edge of gaske t

### Piston, Connecting Rod and Piston Rings

#### NOTE:

Two sizes of piston are available as standard size spare part so as to ensure proper piston-to-cylinder clearance. When installing a standard size piston, make sure to match piston with cylinder as follows.

a) Each piston has a stamped number 1 or 2 as shown depending on its outer diameter.

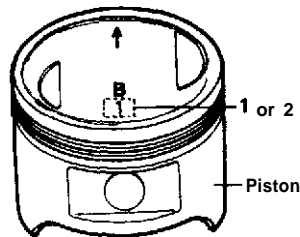


Fig. 3-6-9

b) There are also stamped numbers of 1 and 2 on cylinder block as shown below. First number indicates inner diameter of No. 1 cylinder, second number of No. 2 cylinder, third number of No. 3 cylinder and fourth number of No. 4 cylinder.

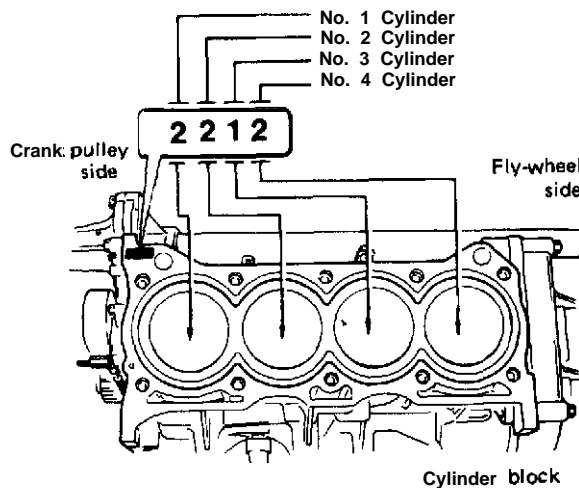


Fig. 3-6- 10

- c) Use a number 2 stamped piston for installation if cylinder is identified with number 2 and a number 1 piston for cylinder with number 1.

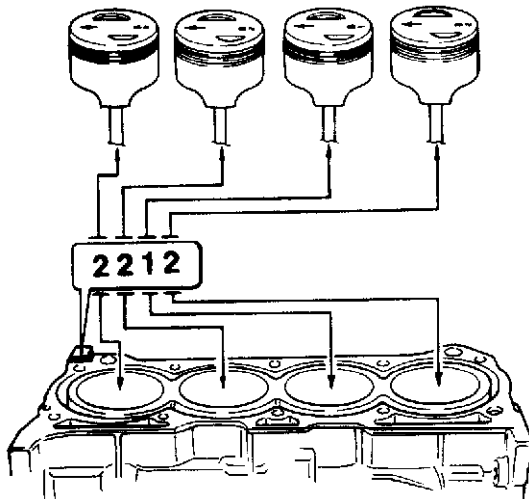


Fig. 3-6- 11

Piston		Cylinder		Piston-to-cylinder clearance
Number at the top (mark)	Outside diameter	Number (mark)	Bore diameter	
1	73.96 - 73.99mm (2.9126 - 2.9130in.)	1	74.01 - 74.02mm (2.9138 - 2.9142in.)	0.02 - 0.04mm (0.0008 - 0.0015in.)
2	73.97 - 73.98mm (2.9122 - 2.9126in.)	2	74.00 - 74.01 mm (2.9134 - 2.9138in.)	0.02 - 0.04mm (0.0008 - 0.0015in.)

Also, a letter A, 6, C etc., is stamped on piston head but ordinarily it is not necessary to discriminate each piston by this number.

1) Install connecting rod to piston.

- ① After applying engine oil to piston pin holes in piston and connecting rod, fit connecting rod to piston as prescribed in Fig. 3-6-12.

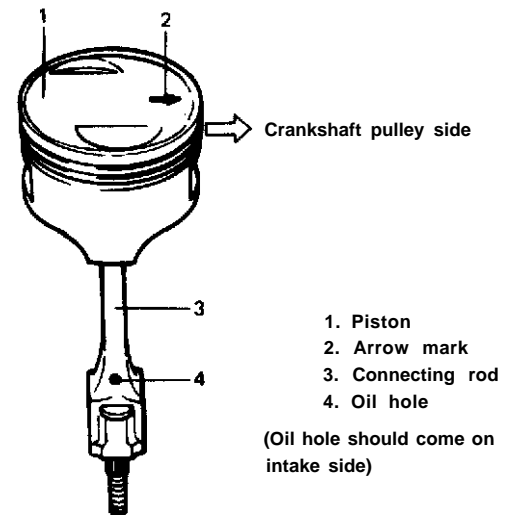


Fig. 3-6- 12 Fitting connecting rod to piston

- ② Place piston on piston pin remover and installer (special tool) as indicated in Fig. 3-6-13, and press piston pin into piston and connecting rod (Fig. 3-6-14).

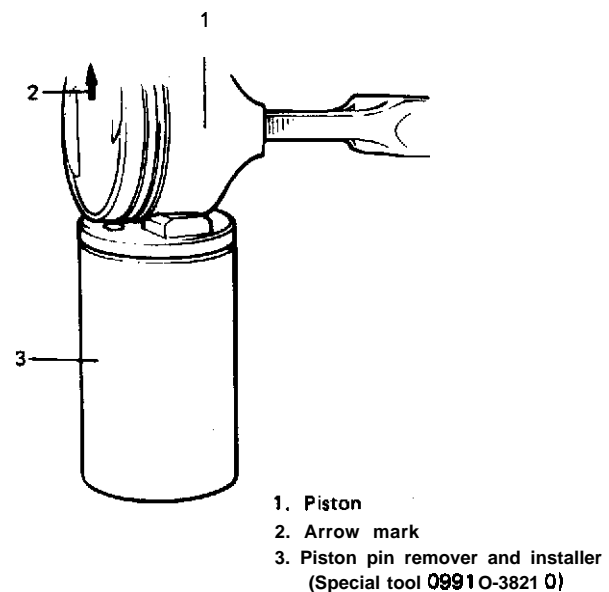


Fig. 3-6- 13 Fitting piston to special tool

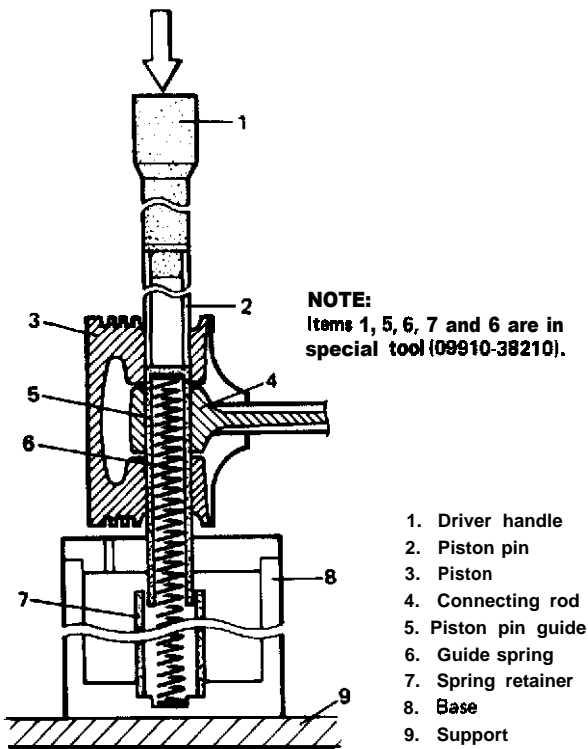


Fig. 3-6-14 Ins tating piston pin

- ③ Press piston pin until line marked on driver handle is flush with flat surface of piston (Fig. 3-6-1 5).

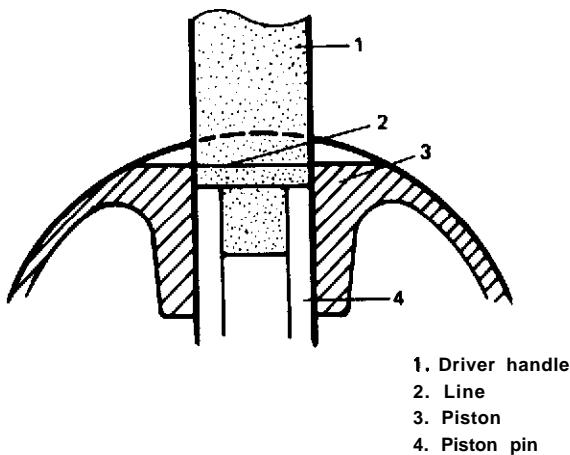


Fig. 3-6- 15 Line marked on driver handle

2) Install piston rings to piston.

- As indicated in Fig. 3-6-16, 1st and 2nd rings have "R" or "T" mark. Installing these piston rings to piston with marked side of each ring faced forward top of piston.
  - 1st ring differs from 2nd ring in thickness, shape and color of the surface contacting cylinder wall.
- Distinguish 1st ring from 2nd ring by referring to Fig. 3-6-16.
- When installing oil ring, install spacer first and then two rails.

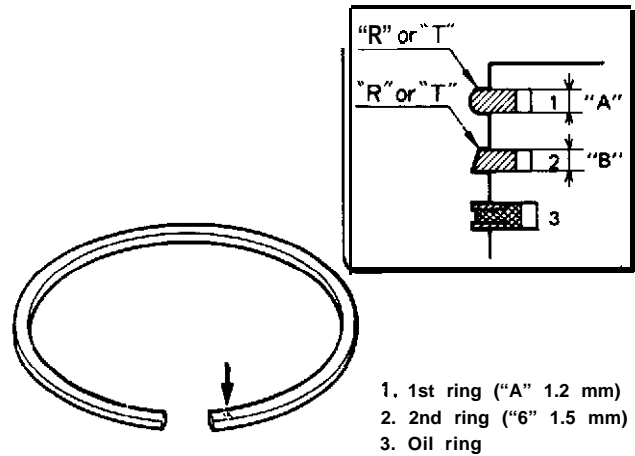


Fig. 3-6-16 Piston rings installation

- After installing 3 rings (1st, 2nd and oil rings), distribute their end gaps as shown in Fig. 3-6-1 7.

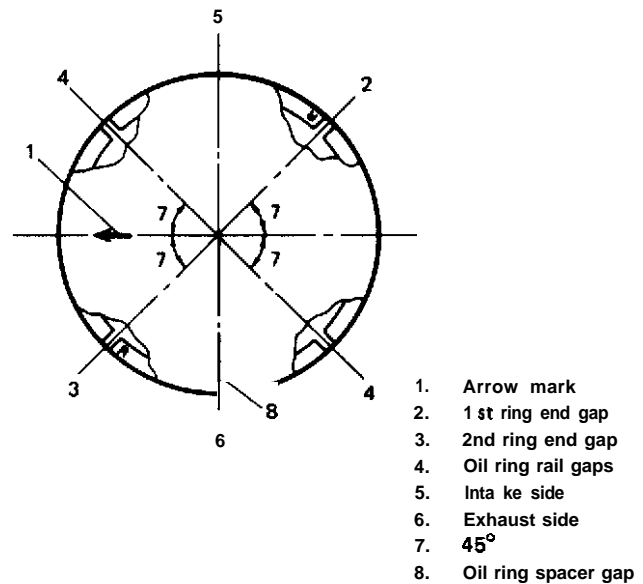


Fig. 3-6- 17 Piston ring end gaps positions



3) install piston and connecting rod assembly into cylinder bore.

@Apply engine oil to pistons, rings, cylinder walls, connecting rod bearings and crankpins.

@Put guide hoses over connecting rod bolts as shown in Fig. 3-6-18. These guide hoses protect crankpin and thread of rod bolt from damage during installation of connecting rod and piston assembly.

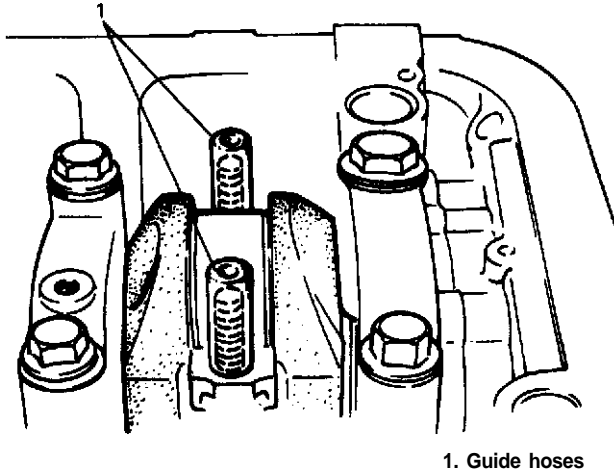


Fig. 3-6- 18 Guide hoses installation

@When installing piston and connecting rod assembly into cylinder bore, point arrow mark on each piston head to crankshaft pulley side.

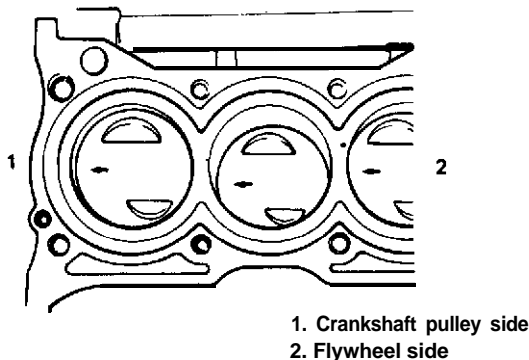


Fig. 3-6- 19 Direction of arrow mark on piston head

④ Use piston ring compressor (Special tool) to compress rings. Guide connecting rod into place on the crankshaft.

Using a hammer handle, tap piston head to install piston into bore. Hold ring compressor firmly against cylinder block until all piston rings have entered cylinder bore.

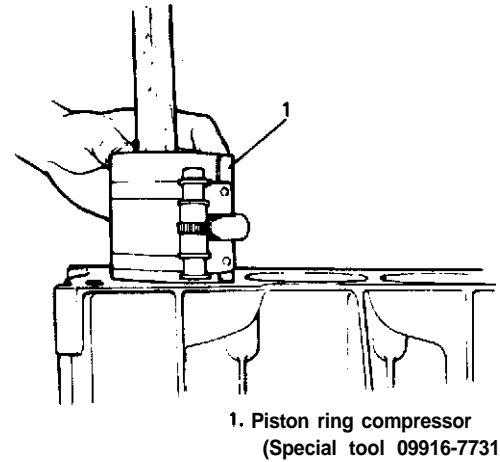


Fig. 3-6-20 Installing piston to cylinder

4) Install connecting rod bearing cap.

When installing cap to rod, point arrow mark on cap to crankshaft pulley side.

Tighten cap nuts to specification.

Tightening torque for rod bearing cap nuts	33 – 37 N-m 3.3 – 3.7 kg-m 24.0 – 26.5 lb-ft
--	--

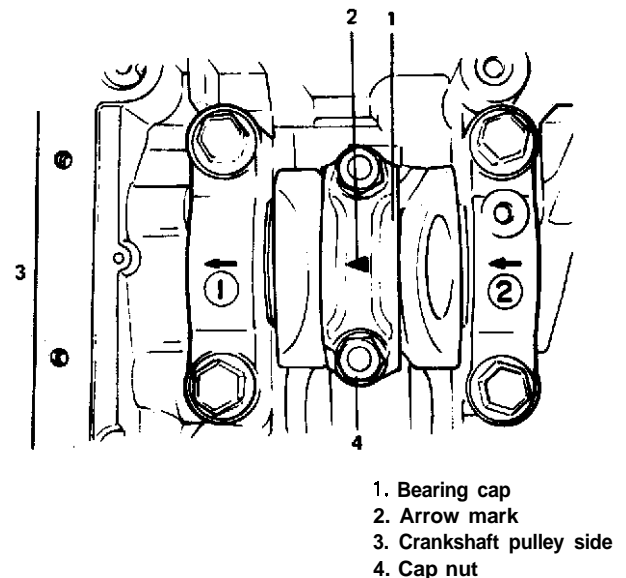


Fig. 3-6-21 Installing bearing cap

## Oil Pump Strainer

Install seal in the position shown in Fig. 3-6-22. Tighten strainer bolt first and bracket bolt to specified torque.

Tightening torque for bolts	9 – 12 N·m 0.9 – 1.2 kg·m 6.5 – 8.5 lb·ft
-----------------------------	---

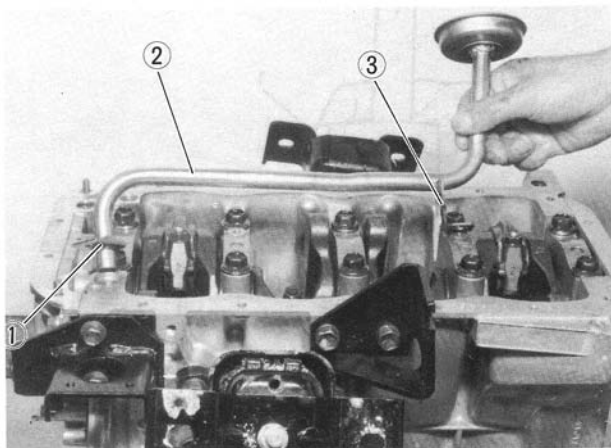


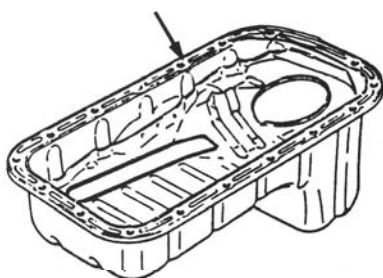
Fig. 3-6-22 Installing seal

1. Seal
2. Strainer
3. Bracket

## Oil Pan

1) Clean mating surfaces of oil pan and cylinder block. Remove oil, old sealant, and dusts from mating surfaces.

After cleaning, apply silicon type sealant to oil pan mating surface continuously as shown in Fig. 3-6-23.



Sealant (99000-31150)

Fig. 3-6-23 Applying sealant to oil pan

2) Install oil pan to cylinder block. After fitting oil pan to block, run in securing bolts and start tightening at the center: move wrench outward, tightening one bolt at a time.

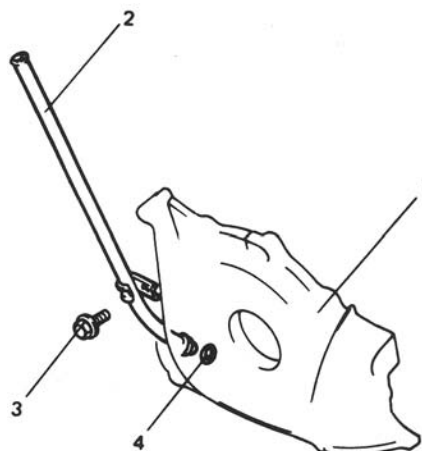
Tighten bolts to specified torque.

Tightening torque for oil pan bolts	9 – 12 N·m 0.9 – 1.2 kg·m 7.0 – 8.5 lb·ft
-------------------------------------	---

3) Install gasket and drain plug to oil pan. Tighten drain plug to specified torque.

Tightening torque for drain plug	30 – 40 N·m 3.0 – 4.0 kg·m 22.0 – 28.5 lb·ft
----------------------------------	--

4) Install guide seal to pump case and then oil level gauge guide.



1. Oil pump
2. Oil level gauge guide
3. Guide bolt
4. Guide seal

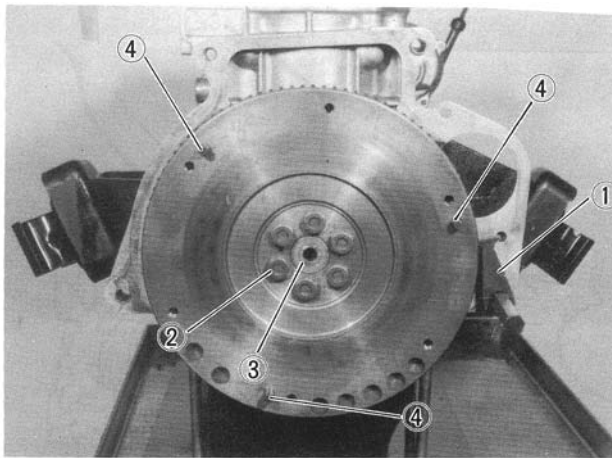
Fig. 3-6-24 Oil level gauge guide

## Flywheel

Install flywheel to crankshaft.

Using special tool, lock flywheel, and tighten flywheel bolts to specification.

Tightening torque for flywheel bolts	57–65 N·m 5.7–6.5 kg·m 41.5 – 47 lb·ft
--------------------------------------	--



1. Flywheel holder (Special tool 09924-I 7810)
2. Flywheel bolts
3. Input shaft end bearing
4. Locating pin

Fig. 3-6-25

### Cylinder Head

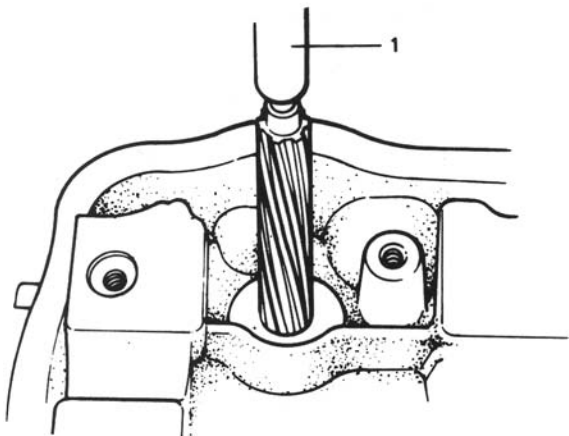
#### NOTE:

- Do not reuse valve guide once disassembled. Install new valve guide (Oversize).
- Intake and exhaust valve guides are identical.

Valve guide oversize	0.03 mm (0.0012 in.)
Valve guide protrusion (In and Ex)	14 mm (0.55 in.)

- 1) Install new valve guide into cylinder head.
  - a) Before installing new valve guide into cylinder head, ream guide hole with 12 mm reamer (Special tool) to remove burrs, making sure that guide hole diameter after reaming comes within specified range.

Valve guide hole Dia. (In & Ex)	12.030 – 12.048 mm (0.4736 – 0.4743 in.)
---------------------------------	---



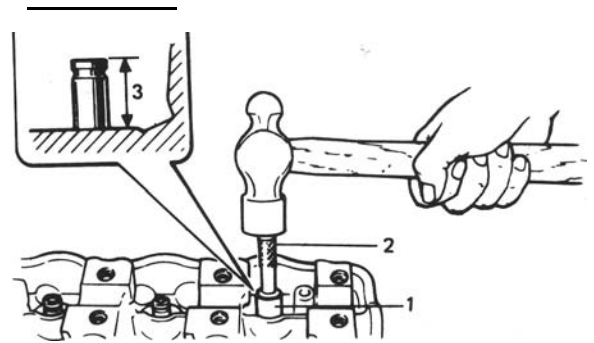
1. 12 mm reamer (Special tool 09916-37310)

Fig. 3-6-26 Reaming guide hole

#### b) Install valve guide to cylinder head.

Heat cylinder head uniformly at a temperature of 80 to 100°C (176 to 212°F), using care not to distort head, and drive new valve guide into hole with special tools. Refer to Fig. 3-6-27.

Drive in new valve guide until valve guide installer (Special tool) contacts cylinder head. After installation, make sure that valve guide protrudes by 14 mm from cylinder head (Fig. 3-6-27).

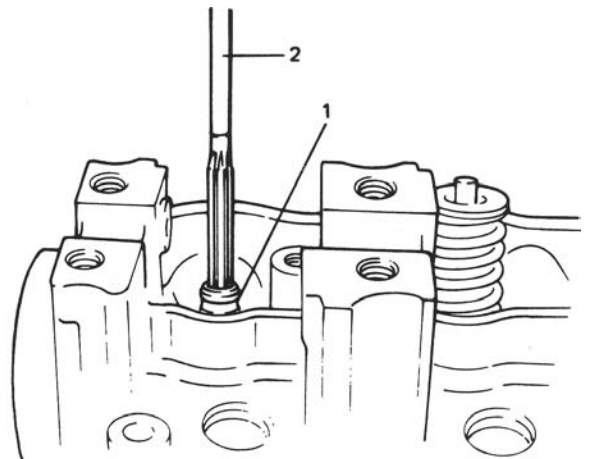


1. Valve guide installer attachment (Special tool 09917-88210)
2. Valve guide installer handle (Special tool 09916-57321)
3. Valve guide protrusion (14 mm)

Fig. 3-6-27 Valve guide installation

#### c) Ream valve guide bore with 7 mm reamer (Special tool).

After reaming, clean bore.



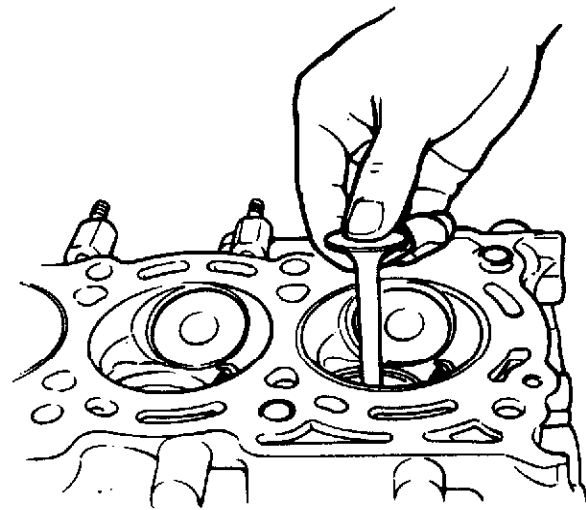
1. Valve guide
2. 7 mm reamer (Special tool 09916-34520)

Fig. 3-6-28 Reaming valve guide bore

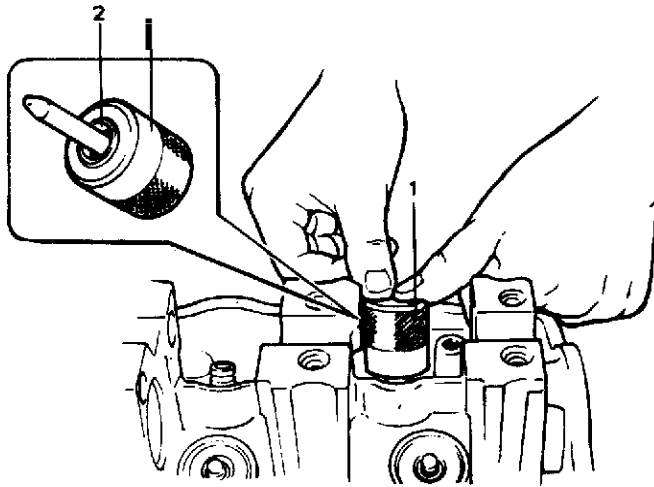
- 2) Install valve spring seat to cylinder head.
- 3) Install new valve stem seal to valve guide.  
After applying engine oil to seal and spindle of valve stem seal installer (special tool), fit oil seal to spindle, and then install seal to valve guide by pushing special tool by hand.  
After installation, check to be sure the seal is properly fixed to valve guide.

**NOTE:**

- Do not reuse oil seal disassembled. Be sure to install new oil seal.
- When installing, never tap or hit special tool with a hammer or else. Install seal to guide only by bushing special tool with hand. Tapping or hitting special tool may cause damage on seal.



**Fig. 3-6-30 Valve installation**

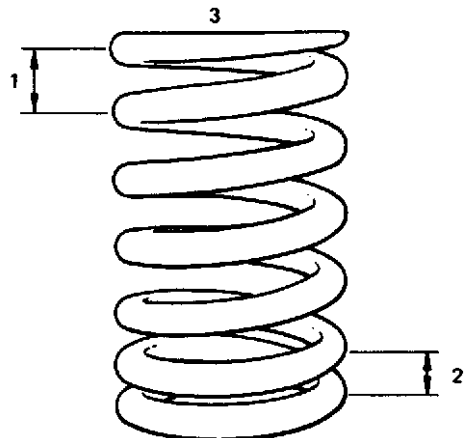


1. Valve stem seal installer (Special tool 09917-98210)
2. Valve stem seal

**Fig. 3-6-29 Valve stem seal installation**

- 4) Install valve to valve guide.  
Before installing valve to valve guide, apply engine oil to stem seal, valve guide bore, and valve stem.

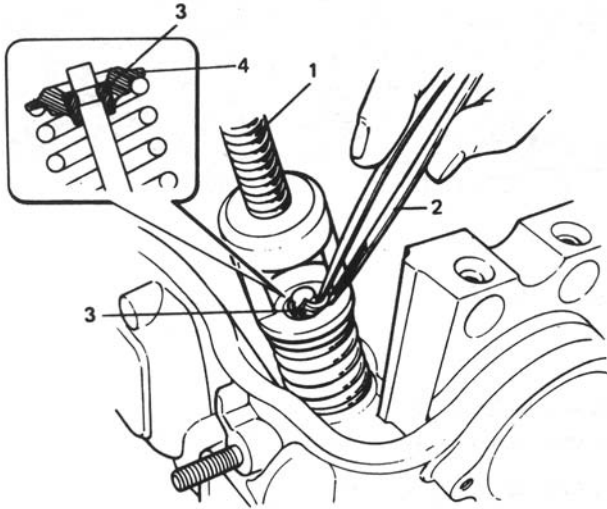
- 5) Install valve spring and spring retainer.  
Each valve spring has top end (large-pitch end) and bottom end (small-pitch end). Be sure to position spring in place with its bottom end (small-pitch end) down to valve spring seat side.



1. Large-pitch
2. Small-pitch
3. Valve spring retainer side
4. Valve spring seat side

**Fig. 3-6-3 1 Valve spring installation**

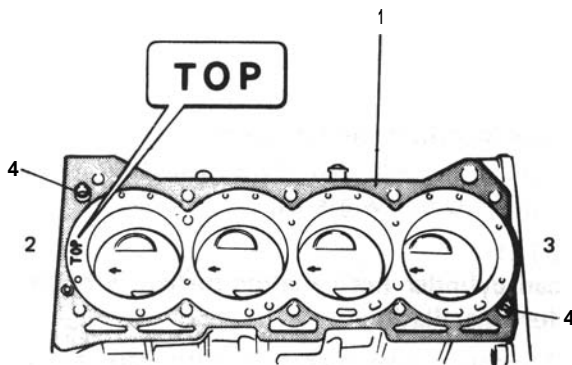
6) Using special tool (Valve lifter), compress valve spring and fit two valve cotters to groove provided in valve stem.



1. Valve lifter (Special tool)
2. Forceps (Special tool)
3. Valve cotters
4. Valve spring retainer

Fig. 3-6-32 Valve cotters installation

7) Be sure that locating pins (4) are in place and then install new head gasket as shown in Fig. 3-6-33, namely in such a way that "TOP" mark provided on the gasket comes on top side (toward cylinder head side) and on crankshaft pulley side.



1. Cylinder head gasket
2. Crankshaft pulley side
3. Flywheel side
4. Locating pin

Fig. 3-6-33 Cylinder head gasket installation

8) Install cylinder head onto cylinder block. Tighten cylinder head bolts gradually with a torque wrench, following sequence in Fig. 3-6-34. Finally tighten bolts to specified torque.

Tightening torque for cylinder head bolts	63 – 70 N·m
	6.3 – 7.0 kg-m
	46.0 – 50.5 lb-ft

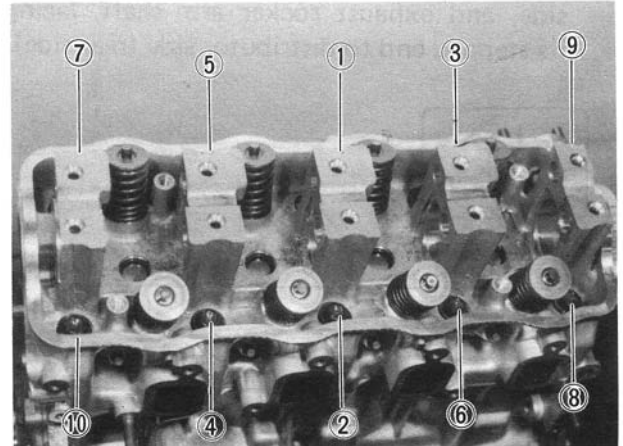


Fig. 3-6-34 Tightening sequence of cylinder head bolts

#### Camshaft

- 1) Apply engine oil to cams and journals on camshaft, and oil seal on cylinder head.
- 2) Install to cylinder head from transmission case side.

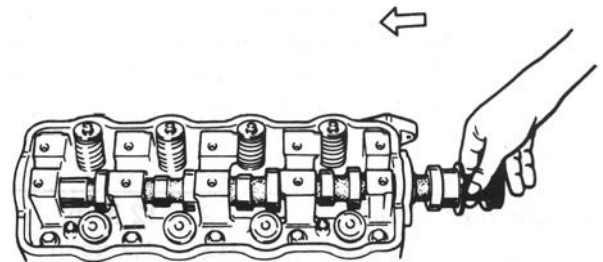
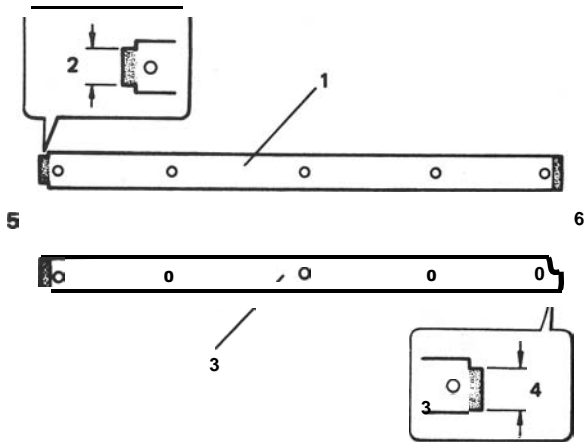


Fig. 3-6-35 Camshaft installation

## Rocker-Arm Shafts

- 1) Apply engine oil to rocker arms and rocker arm shafts.
- 2) Install rocker arms, springs and rocker arm shafts.

The two rocker arm shafts are not identical. To distinguish between the two, dimensions of their stepped ends differ as shown in Fig. 3-6-36. Install intake rocker arm shaft, facing its stepped end to camshaft pulley side, and exhaust rocker arm shaft, facing its stepped end to distributor side (rear side).



1. Intake rocker arm shaft
2. 14 mm (0.55 in)
3. Exhaust rocker arm shaft
4. 15 mm (0.59 in)
5. Camshaft pulley side
6. Distributor side

Fig. 3-6-36 Rocker arm shafts installation

- 3) After installing rocker arms, springs, and rocker arm shafts as shown in Fig. 3-6-37, tighten rocker arm shaft screws to specified torque.

Tightening torque for rocker arm shaft screws	9 – 12 N·m 0.9 – 1.2 kg·m 7.0 – 8.5 lb-ft
---	---

### NOTE:

Valve clearance is adjusted after all parts are assembled. So it is not adjusted at this point. Leave rocker arm adjusting screw as loose as can be.

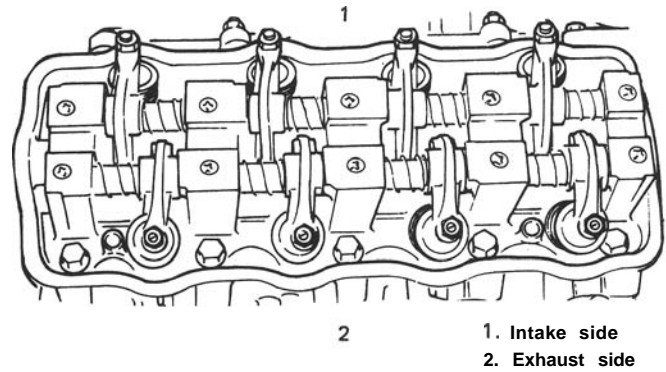


Fig. 3-6-37

## Water Inlet Pipe

Install water inlet pipe to cylinder block.

Make sure to fit seal ring @ (O-ring) to inlet pipe before installation.

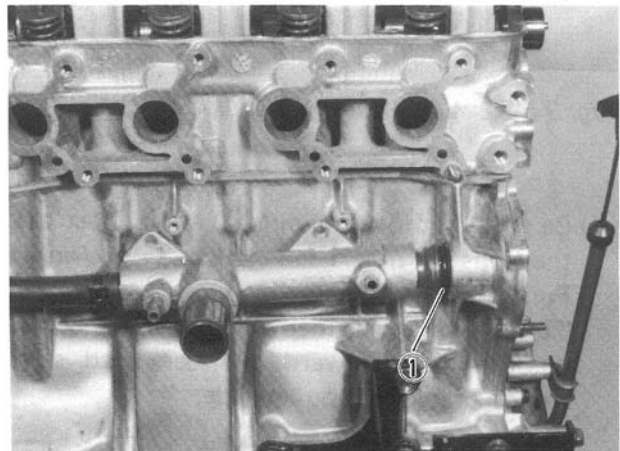


Fig. 3-6-38

## Intake Manifold and Carburetor

- 1) Install intake manifold gasket to cylinder head. Use new gasket.

### NOTE:

Clean cylinder head mating surface with gasket before installation.

- 2) Install intake manifold with carburetor to cylinder head.
- 3) Tighten manifold bolts and nuts to specified torque.

Tightening torque for manifold bolts and nuts	N·m	kg·m	lb-ft
	18 – 28	1.8 – 2.8	13.5-20.0

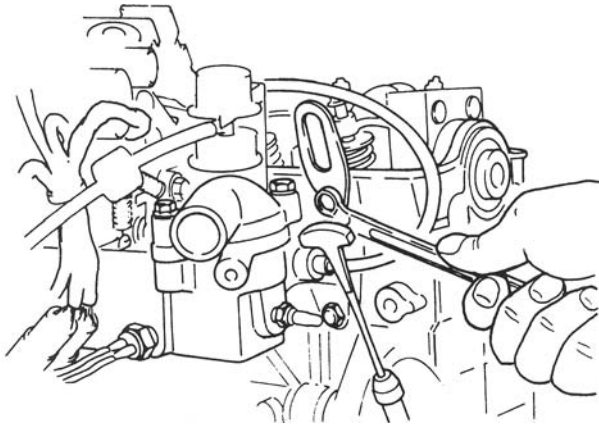


Fig. 3-6-39

- 4) Connect water hoses to water inlet pipe and clamp each hose.

#### Oil Filter

Install oil filter.

**CAUTION:**

For oil filter installation, refer to P. 1-7 of this manual.

#### Exhaust Manifold and Cover

- 1) Install exhaust manifold gasket to cylinder head.

Use new gasket.

**NOTE:**

Clean cylinder head mating surface with gasket before installation.

- 2) Install exhaust manifold to cylinder head.
- 3) Tighten bolts and nuts to specified torque.

Tightening torque for bolts and nuts	N·m	kg·m	lb·ft
	18 – 28	1.8 – 2.8	13.5-20.0

- 4) Install exhaust manifold cover.

#### Water pump

- 1) Install water pump gasket to cylinder block.  
Use new gasket.

**NOTE:**

Clean cylinder block mating surface with gasket before installation.

- 2) Install water pump to cylinder block.
- 3) Tighten bolts and nuts to specified torque.

Tightening torque for water pump bolts and nuts	N·m	kg·m	lb·ft
	9 – 12	0.9 – 1.2	7.0 – 8.5

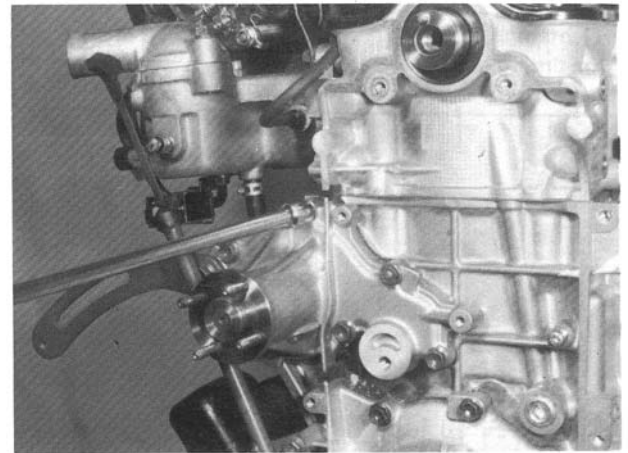


Fig. 3-6-40

- 4) Install rubber seats ①; one between oil pump and water pump and the other between water pump and cylinder head.

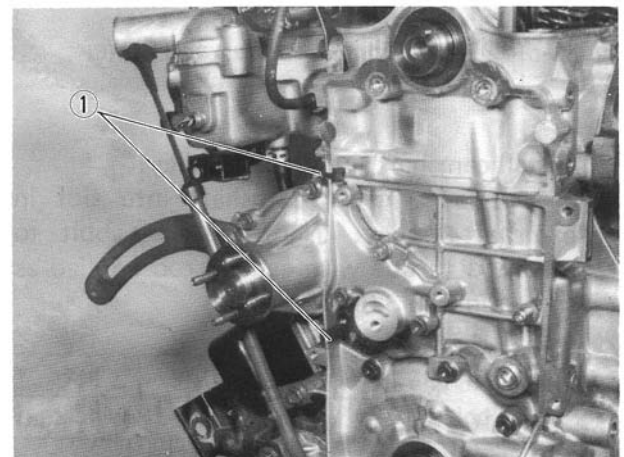


Fig. 3-6-4 1

**Timing Belt Inside Cover, Belt Pulleys, Tensioner, Timing Belt and Outside Cover**

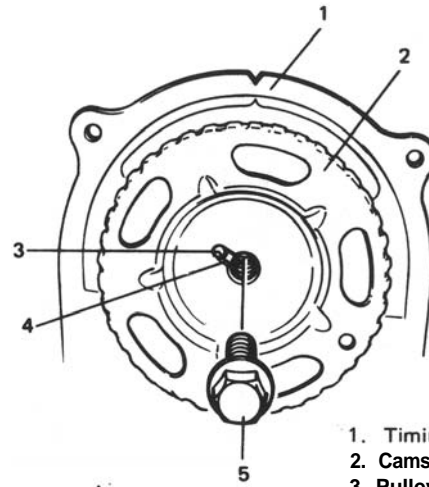
1) install timing belt inside cover to cylinder head.

2) Install crankshaft timing belt guide, key and pulley.

Refer to Fig. 3-6-42 for proper installation of these parts.

Install timing belt guide in such a way that its concave side faces oil pump.

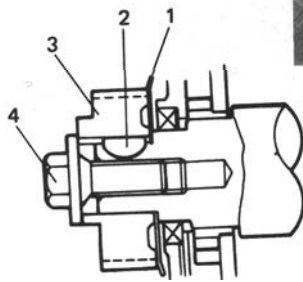
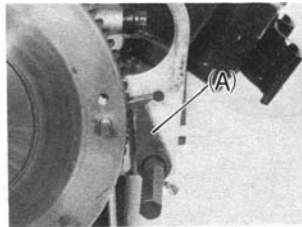
Tighten crankshaft timing belt pulley bolt to specified torque by using flywheel holder A (Special tool).



- 1. Timing belt inside cover
- 2. Camshaft pulley:
- 3. Pulley pin
- 4. Slot
- 5. Pulley bolt

**Fig. 3-6-43 Pulley pin, slot and pulley bolt**

Tightening torque for timing belt pulley bolt	N-m	kg-m	lb-ft
	65 – 75	6.5 – 7.5	47.5–54.0

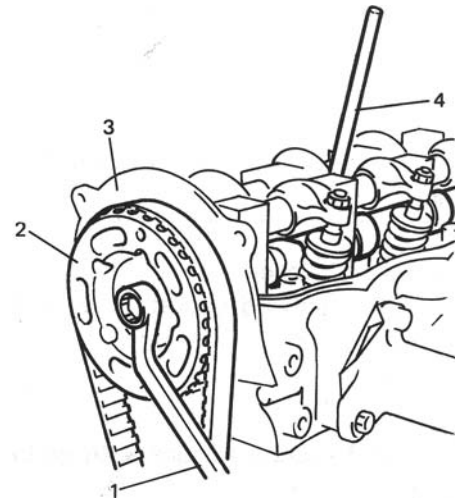


- 1. Timing belt guide
- 2. Key
- 3. Crank timing belt pulley
- 4. Pulley bolt
- (A) Flywheel holder (09924-I 7810)

**Fig. 3-6-42 Installing guide, key and pulley**

3) Install camshaft timing belt pulley.

Fit pulley pin on camshaft into slot in camshaft pulley. Tighten pulley bolt to specified torque with general rod applied as shown in Fig. 3-6-44.



- 1. Wrench
- 2. Camshaft timing belt pulley
- 3. Timing belt inside cover
- 4. General rod

**Fig. 3- 6-44**

Tightening torque for pulley bolt	N-m	kg-m	lb-ft
	56 – 64	5.6 – 6.4	41.0-46.0



- 4) Install timing belt tensioner plate to tensioner.  
Insert lug of tensioner plate into hole of tensioner.

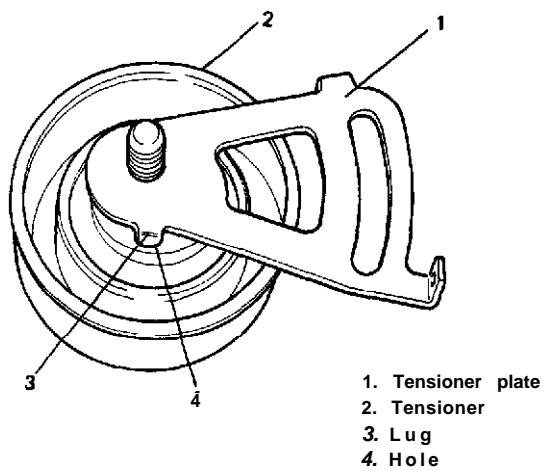


Fig. 3-6-45 Lug and hole

- 5) Install timing belt tensioner, tensioner plate and spring.  
Do not tighten tensioner bolt and stud with wrench yet.  
Hand tighten only at this time.  
Be sure that plate movement in arrow direction as shown in Fig. 3-6-46 causes the same directional movement of tensioner. If no associated movement between plate and tensioner occurs, remove tensioner and plate again and reinsert plate lug into tensioner hole.

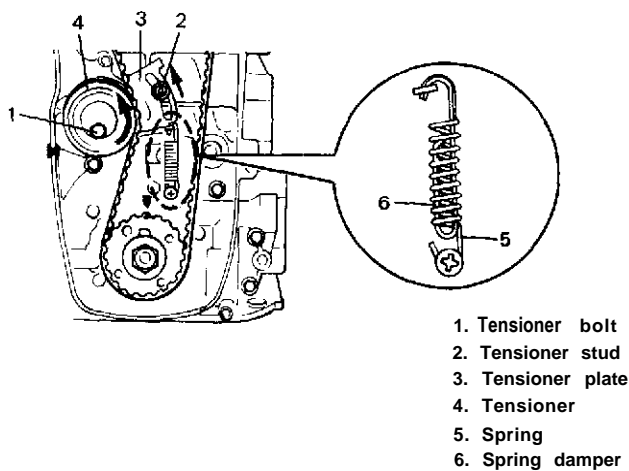


Fig. 3-6-46 Tensioner installation

- 6) Before installing timing belt to camshaft pulley and crankshaft timing belt pulley, loosen all valve adjusting screws of intake and exhaust rocker arms fully, or check to ensure they are loose.

This is to permit free rotation of camshaft for the following reason; when installing timing belt to both pulleys, belt should be correctly tensioned by tensioner spring force. If camshaft does not rotate freely, belt will not be correctly tensioned by tensioner.

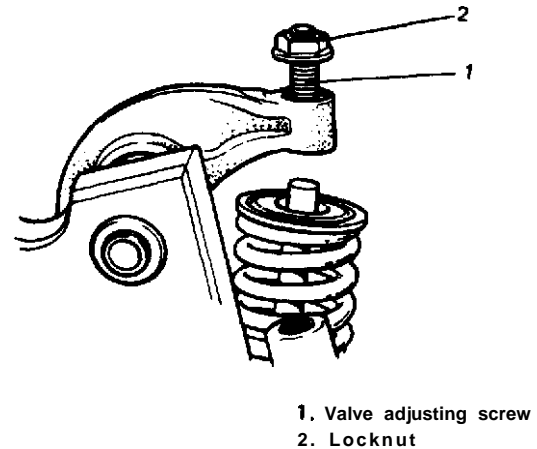


Fig. 3-6-47 Valve adjusting screw and lock nut

- 7) After loosening all valve adjusting screws all the way, turn camshaft pulley clockwise and align timing mark on camshaft pulley with "V" mark on belt inside cover as shown in Fig. 3-6-48.

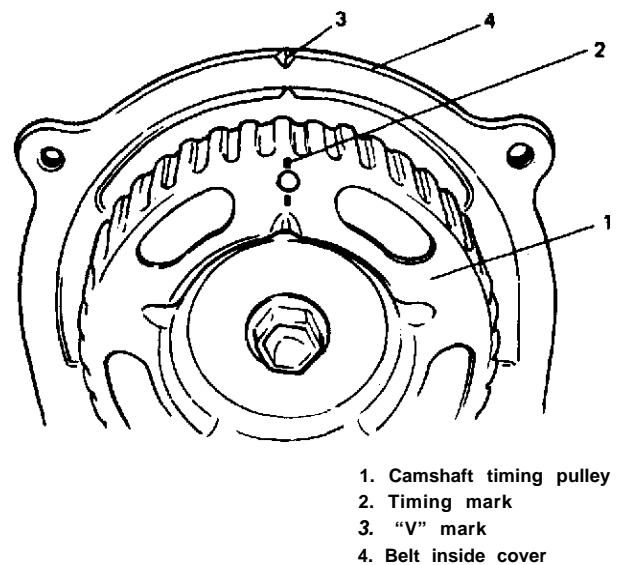
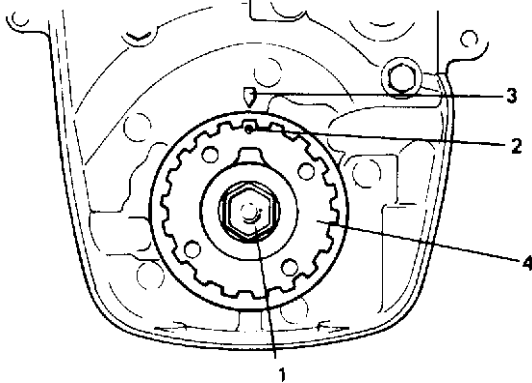


Fig. 3-6-48 Timing marks

8) Turn crankshaft clockwise, fitting 17 mm wrench to crankshaft timing belt pulley bolt, and align punch mark on timing belt pulley with arrow mark on oil pump as shown in Fig. 3-6-49.



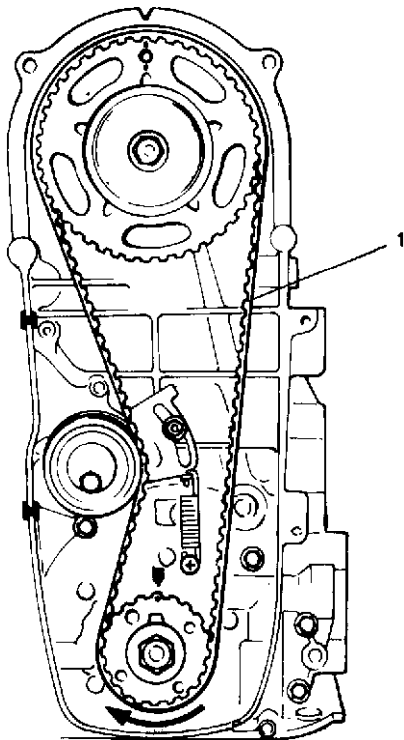
1. Crankshaft timing belt pulley bolt
2. Punch mark
3. Arrow mark
4. Crankshaft timing belt pulley

Fig. 3-6-49 Timing marks

9) With 4 marks aligned, install timing belt on two pulleys in such a way that drive side of belt is free from any slack, and with tensioner plate pushed up by finger.

**NOTE:**

In this state, No.4 piston is at top dead center of compression stroke.



Direction of crankshaft

1. Drive side of belt

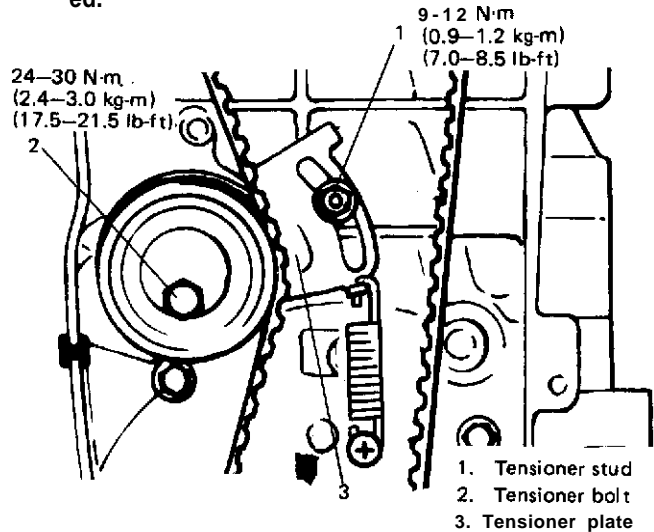
Fig. 3-6-50 Installing timing belt

**NOTE:**

When installing timing belt, match arrow mark (⇒) on timing belt with rotating direction of crankshaft.

10) To allow belt to be free of any slack, turn crankshaft clockwise fully twice after installing belt. After removing belt slack, tighten tensioner stud first and then tensioner bolt to 24 – 30 N·m (2.4 – 3.0 kg·m, 17.5 – 21.5 lb-ft).

Then confirm again that 4 marks are matched.



1. Tensioner stud
2. Tensioner bolt
3. Tensioner plate

Fig. 3-6-51 Tensioner bolt and nut

11) Install timing belt outside cover.

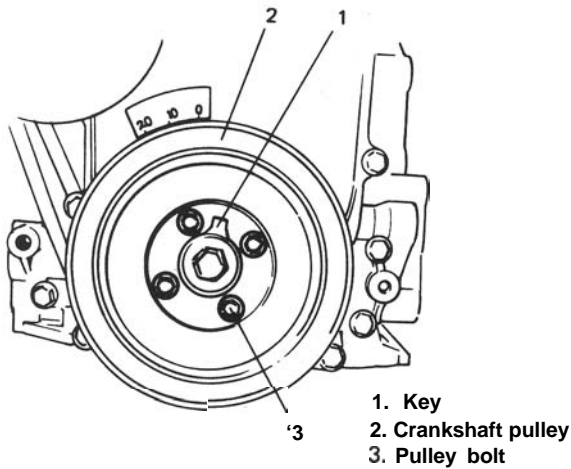
Tightening torque for outside cover bolts and nuts	N·m	kg·m	lb-ft
	9 – 12	0.9 – 1.2	7.0 – 8.5

**Crankshaft Pulley, Water Pump Pulley and Alternator**

1) Install crankshaft pulley.

Fit keyway on pulley to key of crankshaft timing belt pulley, and tighten 4 bolts to specification, with flywheel holder (special tool 09924-17810) hitched to flywheel so that crankshaft will not turn.

Tightening torque for pulley bolts	N·m	kg·m	lb-ft
	10 – 13	1.0 – 1.3	7.5 – 9.0



**Fig. 3-6-52 Installing crankshaft pulley**

2) Install alternator assembly.

Tighten alternator ass'y securing bolts (3pcs) only to the extent to allow alternator to be moved by hand. Don't torque them tight.

**NOTE:**

Adjust water pump belt tension to specification upon completion of installing engine ass'y to body and then cooling fan and water pump pulley. Make sure to refer to p. 1-5 of this manual for adjusting procedure.

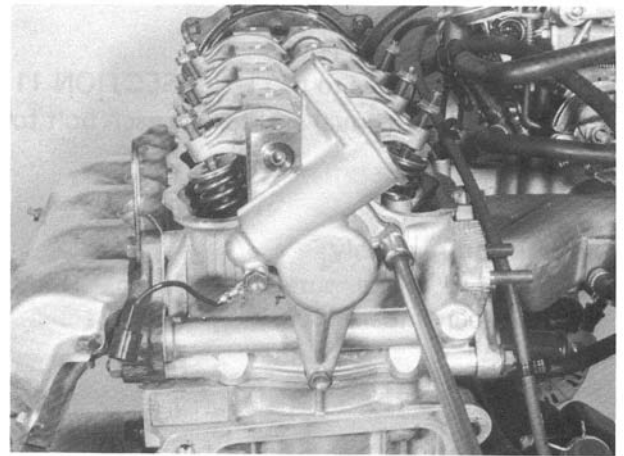
**Distributor Case**

- 1) Install distributor case O-ring to cylinder head.
- 2) Install distributor case.
- 3) Tighten bolts to specified torque.

Tightening torque	N·m	kg-m	lb-ft
for case bolts	8 - 12	0.8 - 1.2	6.0 - 8.5

**CAUTION:**

After tightening case bolts, fill distributor case with about 30cc (1.02/1.06 US/Imp oz) engine oil.

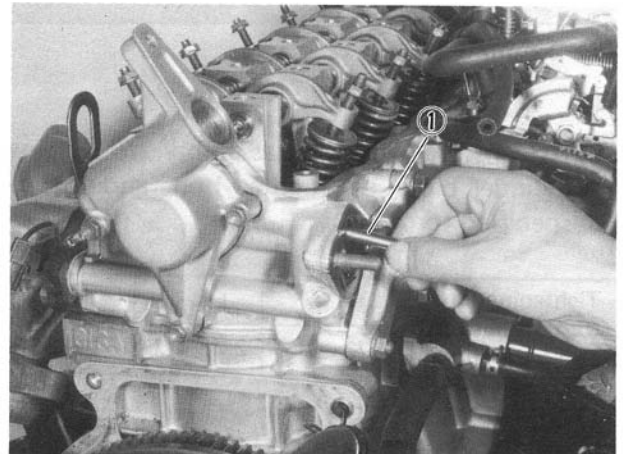


**Fig. 3-6-53**

**Fuel Pump**

Install fuel pump rod, gasket and fuel pump to cylinder head.

Apply engine oil to rod ① before installation. Use new gasket.



**Fig. 3-6-54 Fuel pump rod installation**

### Clutch Disc and Cover

Install clutch disc and cover.

For installation, refer to p. 11-7 of SECTION 11 CLUTCH in this manual and torque each bolt to specification.

### Transmission Assembly

- 1) Check to make sure that 2 pins ① are fitted to cylinder block.

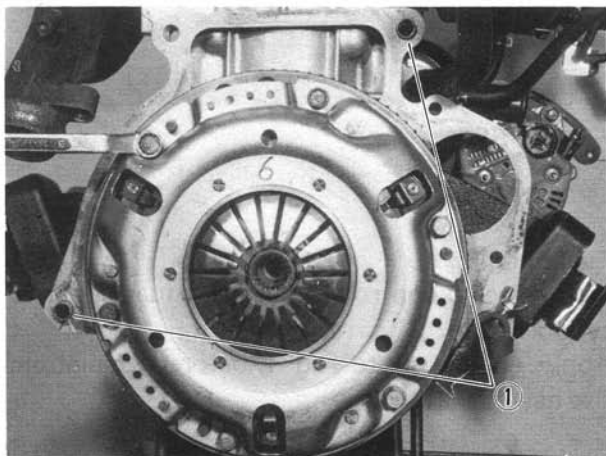


Fig. 3-6-55

- 2) Attach transmission assembly to engine cylinder block and tighten bolts and nuts to specified torque.

Tightening torque	N·m	kg-m	l b-ft
for transmission case bolts and nuts	22 – 35	2.2 – 3.5	16.0-25.0

### Distributor

- 1) Install distributor to case.

For installation, be sure to refer to SECTION 8 IGNITION SYSTEM in this manual.

### NOTE:

Check and adjust ignition timing with engine installed to car body and after installing and connecting all necessary parts. For procedure, refer to p. 8-9 of SECTION 8 IGNITION SYSTEM in this manual.

### Valve Lash (Clearance) Adjustment

Adjust valve lash of all intake and exhaust valves to specification, referring to description on valve lash on p. 3-53 of this manual.

### Cylinder Head Cover

Install cover to cylinder head and tighten bolts to specified torque.

Tightening torque for cylinder head cover bolts	N·m	kg-m	l b-ft
	4 – 5	0.4 – 0.5	3.0 – 3.5

### 3-7. ENGINE INSTALLATION

- 1) Lower engine with transmission into vehicle, but do not remove lifting device.
- 2) Tighten engine mounting bracket bolts (right and left) and transmission mounting bolts to specification. Refer to p. 3-58.
- 3) Remove lifting device.
- 4) Reverse removal procedures for installation of remainder.
- 5) Adjust accelerator cable play and clutch cable play.
- 6) Connect vacuum hoses securely. Refer to section 5 "EMISSION CONTROL SYSTEM" for correct connection.
- 7) Connect wire harnesses and couplers securely.
- 8) Tighten bolts and nuts to specified torque. For individual specification, refer to each section.
- 9) Fill specified amount of specified transmission oil and engine oil. For the detail, refer to SECTION 1 PERIODIC MAINTENANCE SERVICE of this manual.
- 10) After adjusting water pump belt tension to specification, fill specified amount of engine cooling water.
- 11) Before starting engine, check again to ensure that all parts once disassembled or disconnected are back in place securely.
- 12) Start engine and check ignition timing. If it is not to specified timing, adjust it, referring to SECTION 8 of this manual.
- 13) After engine is started, check for oil leak, abnormal noise and other malcondition. Also, check each part for operation.

### 3-8. ENGINE MAINTENANCE SERVICE

#### Fan Belt

Adjust belt tension as outlined in SECTION 6 ENGINE COOLING SYSTEM (p. 6-10).

#### Ignition Timing

Refer to IGNITION TIMING, Page 8-9.

#### Carburetor

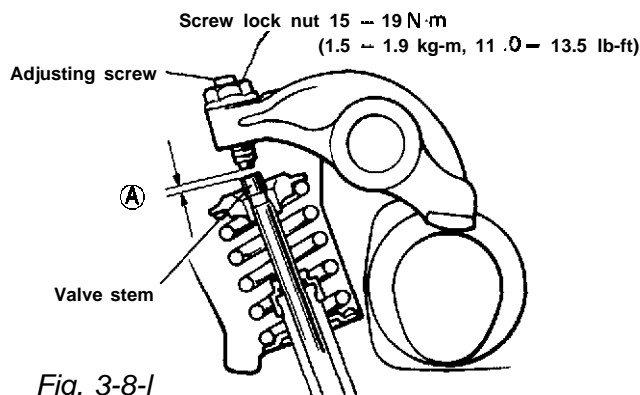
Adjustments to be made are detailed in SECTION 4 (p. 4-19).

#### Valve Lash (Clearance)

Valve lash specifications:

Valve lash refers to gap between rocker arm adjusting screw and valve stem. Use a thickness gauge to measure this gap  $\textcircled{A}$ .

Valve lash (gap A) specification		When cold (Coolant temperature is 15 – 25°C or 69 – 77°F)	When hot (Coolant temperature is 60 – 68°C or 140 – 154°F)
	Intake		0.13 - 0.17 mm (0.0051 - 0.0067 in)
Exhaust		0.16 - 0.20 mm (0.0063 - 0.0079 in)	0.26 - 0.30 mm (0.0102 - 0.0116 in)



Checking and adjusting procedures:

#### NOTE:

- Refer to Fig. 3-3-11 of SECTION 3 for cylinder numbers (No. 1, No. 2, No. 3 and No. 4) mentioned in this section.
- When adjustment becomes necessary in step 4), loosen adjusting screw lock nut and then make adjustment by turning adjusting screw. After adjustment, tighten lock nut to specified torque while holding adjusting screw stationary with straight headed screwdriver, and then make sure again that gap  $\textcircled{A}$  is within specification.

- 1) Remove cylinder head cover.
- 2) Remove ignition timing check window rubber plug from clutch housing of transmission case.
- 3) Turn crankshaft clockwise (viewing from crankshaft pulley side) to the extent that line @above "T" mark punched on flywheel is aligned with match mark ① on transmission case as shown below, i.e. No. 1 cylinder piston reaches TDC position.

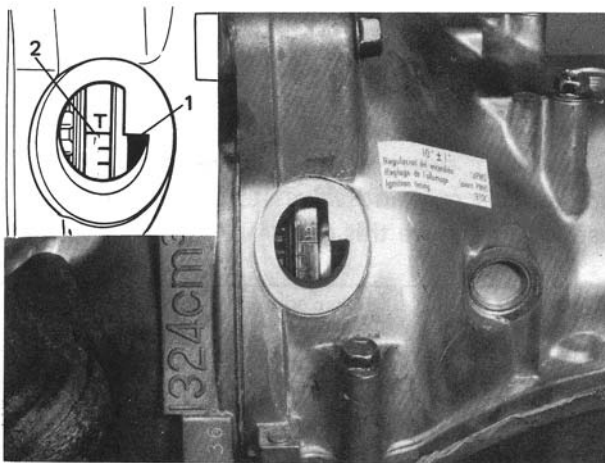


Fig. 3-8-2 1. Match mark 2. "T" (TDC) mark

- 4) Remove distributor cap and check that rotor is positioned as shown in figure. If rotor is out of place, turn crankshaft clockwise once (360"). In this state, check valve lashes at valves ①, ②, @and ⑦. Rotate crankshaft exactly one turn, and check the same at valves ③, ④, ⑥ and ⑧.



Fig. 3-8-3

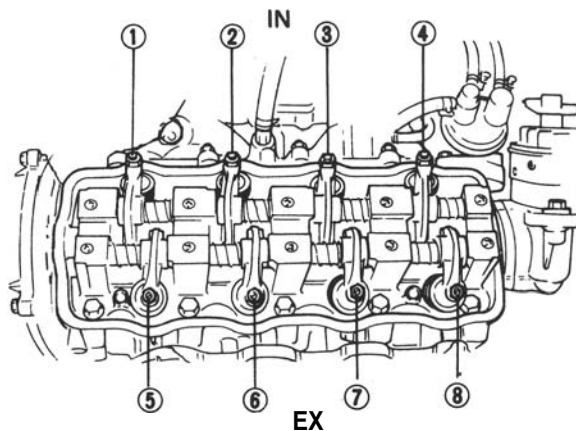


Fig. 3-8-4

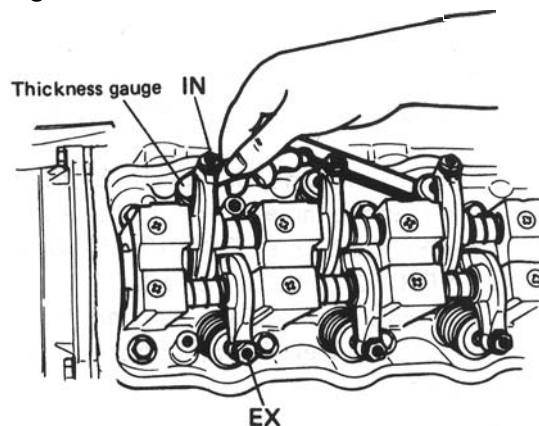


Fig. 3-8-5 Measuring valve lashes

- 5) Upon completion of check and adjustment, install cylinder head cover and torque bolts to specification.

Tightening torque for cylinder head cover bolts	N·m	kg·m	lb·ft
	4 - 5	0.4 - 0.5	3.0 - 3.5

- 6) Install distributor cap and connect blow-by gas hose to cylinder head cover.

#### Camshaft Timing Belt

For checking procedures of damage, wear and tension of camshaft timing belt, refer to SECTION 1 (p. 1-5) of this manual.

#### Engine Oil

Refer to SECTION 1 (p. 1-7) of this manual.

#### Engine Oil Filter

For removal and installation of filter, refer to SECTION 1 (p. 1-7) of this manual.

### Engine Coolant

This subject is covered in SECTION 6 ENGINE COOLING SYSTEM.

### Exhaust Line and Muffler

Inspect each exhaust line connection for tightness, and examine muffler and other parts for evidence of breakage and leakage of gases. Repair or replace defective parts, if any.

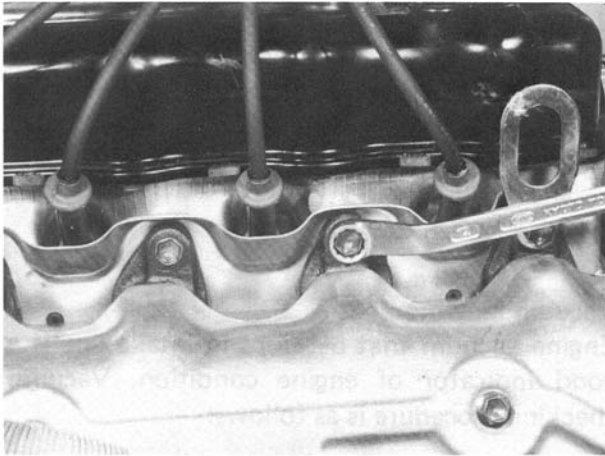
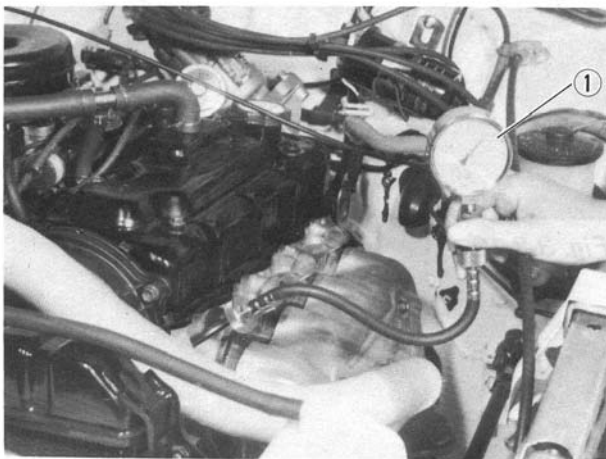


Fig. 3-8-6

### Compression Pressure Measurement

Check compression pressure on all four cylinders as follows:

- 1) Warm up engine.
- 2) Stop engine after warming up.
- 3) Remove all spark plugs and disconnect high tension cord from ignition coil.
- 4) Install compression gauge (special tool) into spark plug hole.



1. Compression gauge (Special tool 09915-64510)

Fig. 3-8-7 Installing compression gauge

- 5) Disengage clutch (to lighten starting load on engine), and depress accelerator pedal all the way to make throttle full-open.
- 6) Crank engine with fully charged battery, and read the highest pressure on compression gauge.

	Compression pressure
Standard	<b>14.0 kg/cm<sup>2</sup></b> (199.0 psi) 400 r/min
Limit	<b>12.0 kg/cm<sup>2</sup></b> (170.0 psi) 400 r/min
Max. difference between any two cylinders	<b>1.0 kg/cm<sup>2</sup></b> (14.2 psi), 400 r/min

- 7) Carry out steps 4) through 6) on each cylinder to obtain four readings.

#### NOTE:

Compression pressure value is measured by using compression gauge (Special tool 09915-64510).

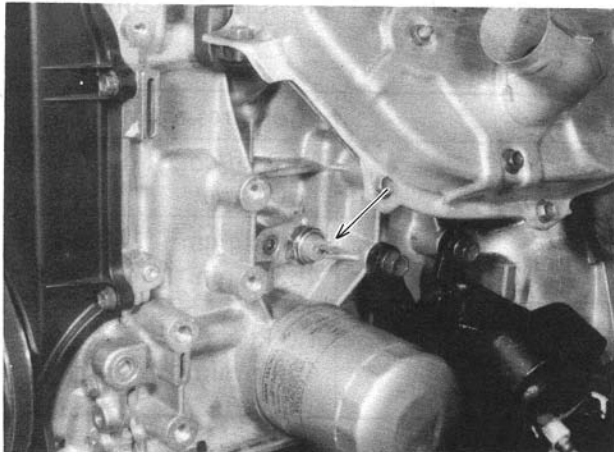
### Oil Pump Discharge Pressure Measurement

#### NOTE:

Prior to checking oil pressure, check the following.

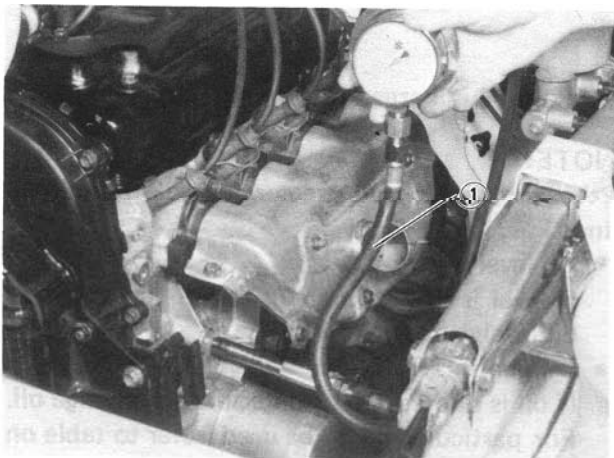
- Oil level in oil pan.  
If level is low, add oil up to Full level hole on oil level gauge.
- Oil quality.  
If oil is discolored, or deteriorated, change oil. For particular oil to be used, refer to table on p 1-8 of SECTION 1.
- Oil leak.  
If leak is found, repair it

- 1) Disconnect lead wire from oil pressure switch.
- 2) Remove oil pressure switch from cylinder block.



**Fig. 3-8-8 Oil pressure switch**

- 3) Install oil pressure gauge (special tool) to vacated threaded hole.



1. Oil pressure gauge (Special tool 09915-77310)

**Fig. 3-8-9 Oil pressure gauge installation**

- 4) Start engine and warm it up to normal operating temperature.
- 5) After warming up, raise engine speed to 3,000 r/min and measure oil pressure.

Oil pressure specification	3.0-4.2 kg/cm <sup>2</sup> 42.7-59.7 psi at 3,000 r/min (rpm)
----------------------------	---

- 6) After checking oil pressure, stop engine and remove oil pressure gauge.
- 7) Before reinstalling oil pressure switch, be sure to wrap its screw threads with sealing tape and tighten switch to specified torque.

Tightening torque for oil pressure switch	12 – 15 N·m 1.2 – 1.5 kg·m 9.0 – 10.5 lb·ft
---	---

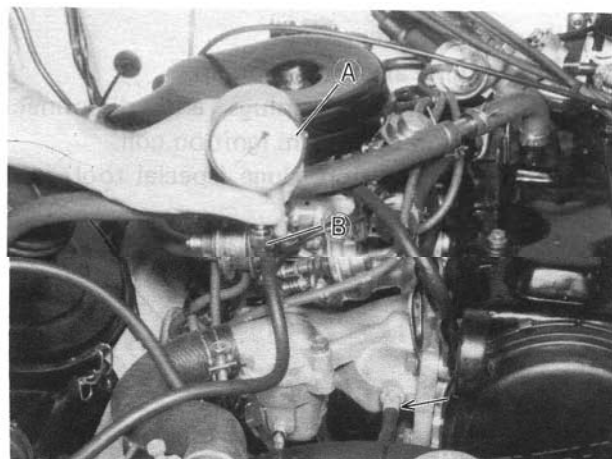
**NOTE:**

- If sealing tape edge is bulged out from screw threads of switch, cut off edge.
- 8) After installing oil pressure switch, start engine and check switch for oil leakage.

**Vacuum Measurement**

Engine vacuum that develops in intake line is a good indicator of engine condition. Vacuum checking procedure is as follows:

- 1) Warm up engine to normal operating temperature.
- 2) Install vacuum gauge (A) (09915-67310), as shown in Fig. 3-8-10. Install engine tachometer.



**Fig. 3-8-10**



- 3) Run engine at specified idling speed and, under this running condition, read vacuum gauge. Vacuum should not be lower than 45 cm Hg (17.7 in. Hg).

A low vacuum reading means that any combination of following malconditions is the cause, which must be corrected before releasing machine to customer:

- (a) Leaky cylinder head gasket
- (b) Leaky inlet manifold gasket
- (c) Leaky valves
- (d) Weakened valve springs
- (e) Maladjusted valve clearance
- (f) Valve timing out of adjustment
- (g) Ignition mistimed
- (h) Carburetor improperly adjusted

**NOTE:**

Should indicating hand of the vacuum gauge oscillate violently, turn adjusting nut **Ⓑ** to steady it

Standard vacuum (sea level)	45 – 55cm Hg (17.7 – 21.6 in. Hg)
Idling speed specification	BOO ± 50 r/min (rpm) (Take vacuum reading at this speed.)

- 4) After checking, remove vacuum gauge.
- 5) Before reinstalling vacuum checking plug, be sure to wrap its screw threads with sealing tape and tighten plug.

**Oil Filler Cap**

The cap has a packing. Be sure that packing is in good condition, free of any damage and signs of deterioration, and is tight IN place: it is replaceable.

### 3-9. RECOMMENDED TORQUE SPECIFICATIONS

Fastening parts	Tightening torque		
	N-m	kg-m	lb-ft
1. Cylinder head bolt	63-70	6.3 – 7.0	46.0 – 50.5
2. Cylinder head cover bolt	4 - 5	0.4 – 0.5	3.0 – 3.5
3. Spark plug	20 - 30	2.0 – 3.0	14.5 – 21.5
4. Distributor gear case	8 – 12	0.8 – 1.2	6.0 – 8.5
5. Rocker arm shaft screw	9 – 12	0.9 - 1.2	7.0 - 8.5
6. Valve adjusting screw lock nut	15 – 19	1.5 - 1.9	11.0 – 13.5
7. Crankshaft main bearing cap bolt	50 – 57	5.0 – 5.7	36.5 – 41.0
8. Oil filter stand	20-25	2.0 – 2.5	14.5 – 18.0
9. Oil filter Ass'y	12 – 16	1.2 – 1.6	9.0 – 11.5
10. Oil pressure switch	12 – 15	1.2 – 1.5	9.0 – 10.5
11. Oil drain plug	30 - 40	3.0 – 4.0	22.0 – 28.5
12. Oil pan bolt and nut	9 – 12	0.9 – 1.2	7.0 – 8.5
13. Oil pump strainer bolt	9 – 12	0.9 – 1.2	7.0 – 8.5
14. Water pump bolt and nut	9 - 12	0.9 – 1.2	7.0 – 8.5
15. Cooling fan nut	8 – 12	0.8 – 1.2	6.0 - 8.5
16. Flywheel bolt	57 – 65	5.7 – 6.5	41.5-47.0
17. Oil seal housing bolt	9 – 12	0.9 – 1.2	7.0 – 8.5
18. Connecting rod bearing cap nut	33-37	3.3 - 3.7	24.0 – 26.5
19. Crankshaft pulley bolt	10 – 13	1.0 – 1.3	7.5 – 9.0
20. Crankshaft timing belt pulley bolt	65 – 75	6.5 – 7.5	47.5 – 54.0
21. Timing belt cover bolt and nut	9 – 12	0.9 – 1.2	7.0 – 8.5
22. Camshaft timing pulley bolt	56 – 64	5.6 – 6.4	41.0 – 46.0
23. Timing belt tension bolt	24 – 30	2.4 – 3.0	17.5 – 21.5
24. Timing belt tensioner stud	9 – 12	0.9 – 1.2	7.0 – 8.5
25. Oil pump case bolt	9 – 12	0.9 – 1.2	7.0 - 8.5
26. Oil pump rotor plate screw	9 – 12	0.9 - 1.2	7.0 – 8.5
27. Inlet & exhaust manifold nut	18 - 28	1.8 - 2.8	13.5 – 20.0
28. Fuel pump nut	10 – 16	1.0 - 1.6	7.0 – 11.5
29. Engine mounting bracket frame side bolt	40 – 60	4.0 – 6.0	29.0 – 43.0
30. Engine mounting bracket engine side bolt	50 – 60	5.0 - 6.0	36.5 – 43.0
31. Engine mounting nut	40 - 50	4.0 – 5.0	29.0 – 36.0
32. Transmission mounting bracket bolt	18 - 28	1.8 – 2.8	13.5 – 20.0
33. Transmission mounting bolt	18 - 28	1.8 – 2.8	13.5 – 20.0
34. Transmission mounting and frame bolt	18 - 28	1.8 – 2.8	13.5 – 20.0
35. Propeller shaft flange bolt and nut	23 – 30	2.3 – 3.0	17.0 – 21.5

NOTE: If specified tightening torque for particular bolt or nut is not included here, refer to p O-12 of this manual.

## SECTION 4

# FUEL SYSTEM

### CONTENTS

4-1. CARBURETOR .....	4-2
GENERAL DESCRIPTION .....	4-2
REMOVAL AND INSTALLATION .....	4-12
UNIT REPAIR OVERHAUL .....	4-13
MAINTENANCE SERVICES .....	4-19
4-2. AIR CLEANER .....	4-29
GENERAL DESCRIPTION .....	4-29
MAINTENANCE SERVICES .....	4-29
4-3. FUEL PUMP, FILTER AND LINES .....	4-31
GENERAL DESCRIPTION .....	4-31
REMOVAL AND INSTALLATION .....	4-33
MAINTENANCE SERVICES .....	4-35
4-4. ACCELERATOR PEDAL .....	4-36

**CAUTION:**

THE ENGINE OF THIS VEHICLE REQUIRED THE USE OF UNLEADED FUEL ONLY. USE OF LEADED AND/OR LOW LEAD FUEL CAN RESULT IN ENGINE DAMAGE AND REDUCE THE EFFECTIVENESS OF THE EMISSION CONTROL SYSTEMS.

## 4-1. CARBURETOR

### GENERAL DESCRIPTION

#### General

This 2-barrel downdraft type carburetor has primary and secondary systems.

The primary system operates under normal driving condition, and the secondary system operates under high speed-high load driving condition. The choke valve is provided in the primary system.

The main components and their functions are as follows.

- The primary system has; (1) a mixture control solenoid valve which is operated by the electrical signals from the Electronic Control Module (ECM) so as to maintain the optimum air fuel ratio of the primary slow and the primary main systems at all times, (2) a fuel cut solenoid valve which is for the fuel cut under deceleration and prevention of the dieseling, and (3) an acceleration pump system.
- The secondary system has a secondary diaphragm which is operated by the vacuum from the primary side and actuates the secondary throttle valve.
- The choke system is a full automatic type using a thermo-wax.
- The switch vent solenoid valve provided on top of the float chamber is to reduce the evaporative emissions.

1. Air horn
2. Float chamber
3. Throttle chamber
4. Pump boot
5. Pump lever
6. Pump rod
7. Bracket
8. screw
9. Thermo element holder
10. Seal
11. Thermo element
12. Choke piston
13. Delay valve
14. Switch vent solenoid
15. Vacuum switching valve
16. 3 way joint
17. Vacuum transmitting valve
16. Primary slow air No. 1 bleeder
19. Secondary slow air bleeder
20. Mixture control solenoid valve
21. Solenoid valve seal
22. Needle valve filter
23. Needle valve gasket
24. Needle valve
25. Float
26. Air horn gasket
27. Connector (5 terminal)
28. Connector (4 terminal)
29. Connector (1 terminal)
30. injector weight
31. Injector spring
32. Injector weight
33. ball
34. Primary slow air No. 2 bleeder
35. Primary slow jet
36. Primary main air bleeder
37. Secondary main air bleeder
38. Spring
39. Secondary slow jet
40. Idle micro switch
41. Wide open micro switch
42. Idle up actuator
43. Solenoid valve (Fuel cut)
44. Washer
45. Level gauge seal
46. Level gauge
47. Level gauge gasket
48. Micro switch bracket
49. Primary main jet
60. Secondary main jet
51. Drain plug gasket
52. Drain plug
53. Float pin
54. Insulator
56. Secondary actuator (diaphragm)

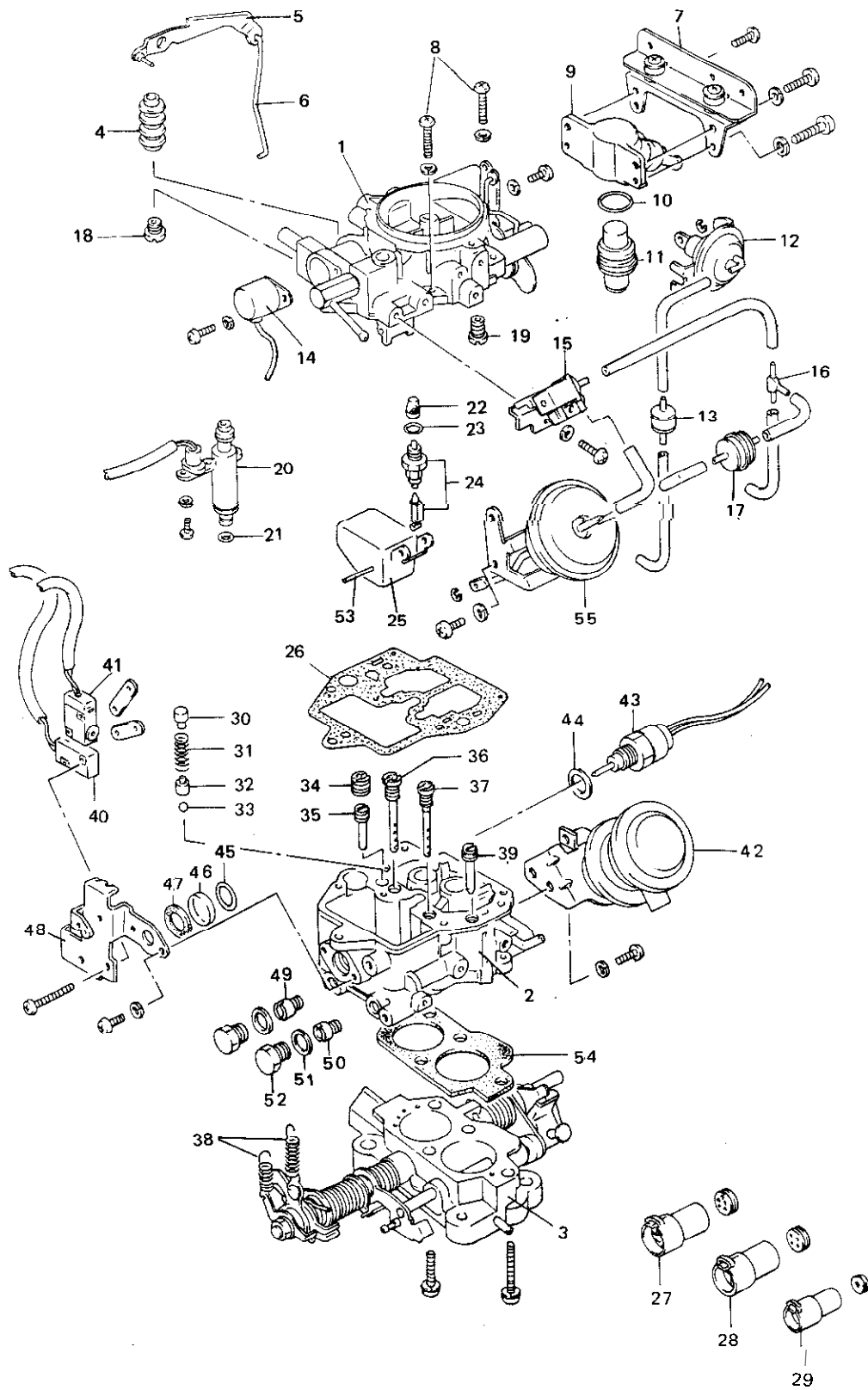


Fig. 4-1-1 Carburetor exploded view

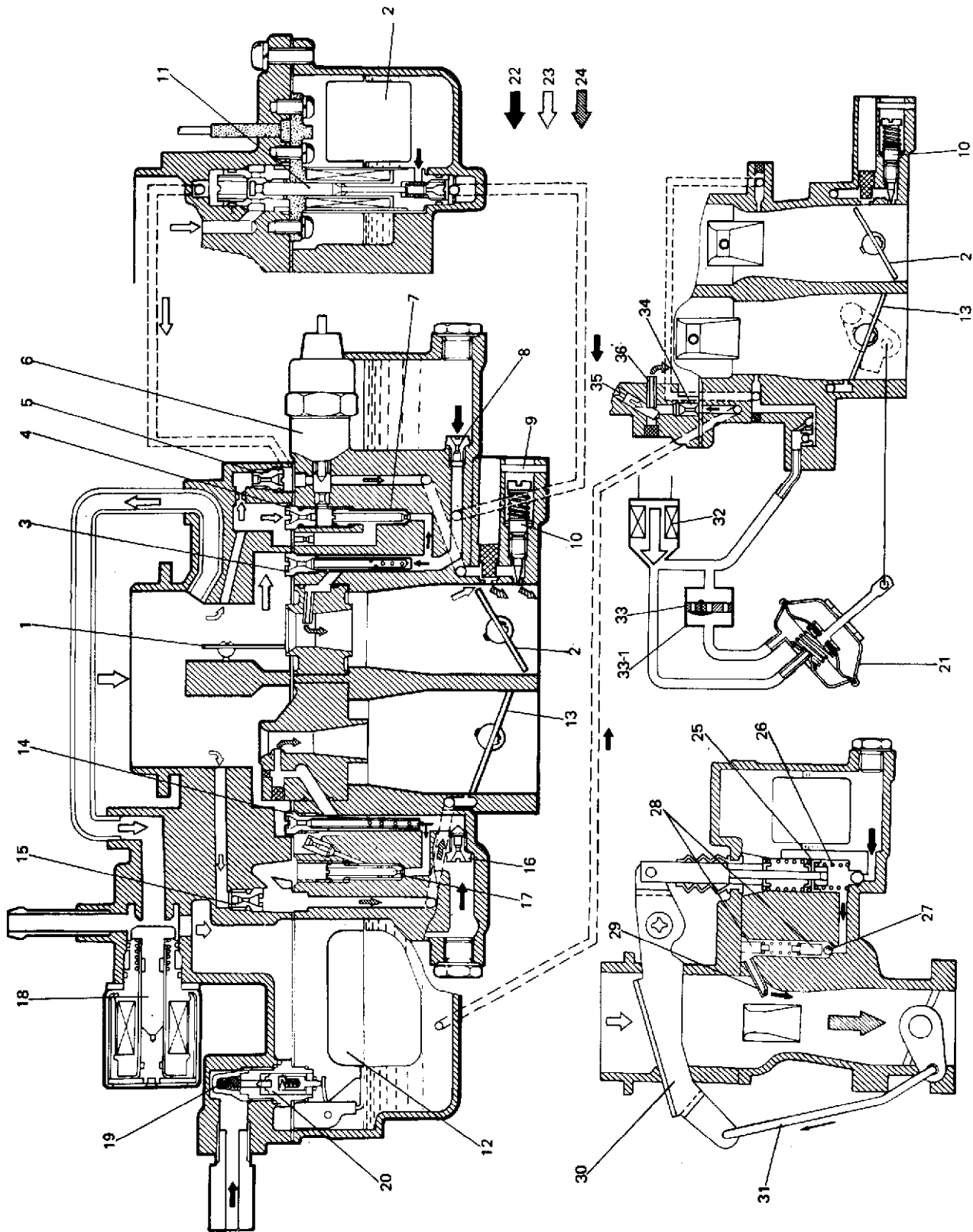
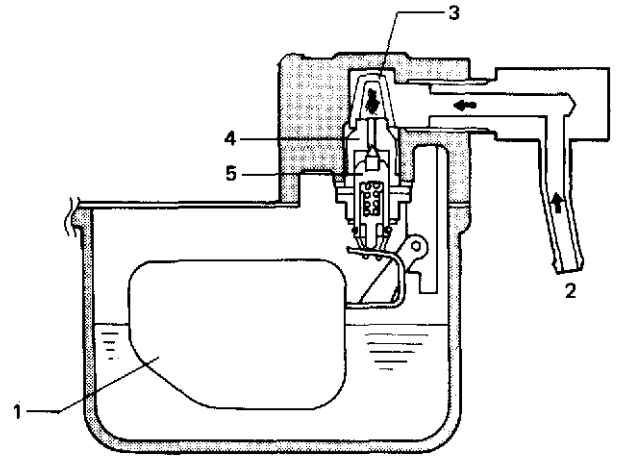


Fig. 4- 1-2 Carburetor cross-section

1. Choke valve
2. Primary throttle valve
3. Primary main air bleeder
4. Primary slow air No. 2 bleeder
5. Primary slow air No. 1 bleeder
6. Solenoid valve (Fuel cut)
7. Primary slow jet
8. Primary main jet
9. Mixture adjusting screw pin
10. Mixture adjusting screw
11. Mixture control solenoid valve
12. Float
13. Secondary throttle valve

14. Secondary main air bleeder
15. Secondary slow air bleeder
16. Secondary main jet
17. Secondary slow jet
18. Switch vent solenoid
19. Needle valve filter
20. Needle valve
21. Secondary (actuator) diaphragm
22. Fuel
23. Air
24. Air/Fuel mixture
25. Pump piston
26. Return spring

27. Ball
28. Injector weight
29. Discharge nozzle
30. Pump lever
31. Pump rod
32. VSV (Vacuum switching valve)
33. VTV (Vacuum transmitting valve)
- 33-1 Brown side
34. Richer jet
35. Richer air bleeder
36. Richer nozzle



1. Float
2. From fuel pump
3. Needle valve filter
4. Needle valve seat
5. Needle valve

Fig. 4- 1-3 Float system

## Float System

The float system consists of a float chamber, a float, a float needle valve and seat, and needle valve filter. Fuel from the fuel pump enters the float chamber, passing through the needle valve filter and the needle valve.

The float's function is to maintain a constant level in the chamber.

As the fuel level in the chamber drops, the float and the needle valve drops down allowing the fuel to enter the chamber. As the fuel enters the chamber, the float and the needle valve again rise to close the fuel inlet.

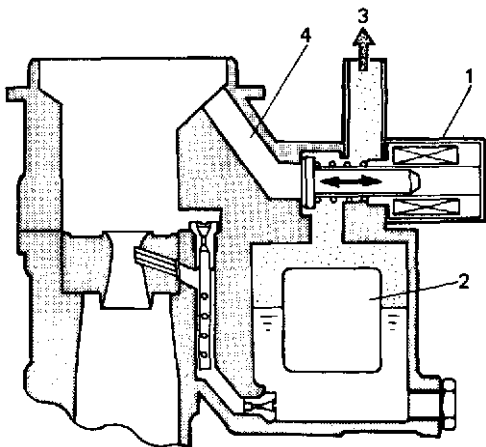
A constant fuel level in the chamber is maintained through the repetition of this cycle.

#### [Switch vent solenoid]

Provided on top of the float chamber is a switch vent solenoid which is connected to the ignition switch through ECM. As the ignition switch is operated, the solenoid opens and closes its valve so as not to release the fuel vapor in the float chamber out into the atmosphere.

When the ignition switch is turned to "OFF" position, the passage connecting the inner vent passage and the float chamber will close, and the passage connecting the float chamber and the canister will open, then the fuel vapor will flow into the canister.

When the ignition switch is turned to "ON" position, and engine speed is above 400 r/min, the passage connecting the float chamber and the canister will close, and the passage connecting the float chamber and the inner vent passage will open, then the fuel vapor will flow into the carburetor bore.



1. Switch vent solenoid
2. Float
3. To canister
4. Inner vent passage

Fig. 4- I-4 Switch vent solenoid

#### Primary System

##### [Primary slow system]

The fuel, after passing through the main jet, is metered by the primary slow jet, then mixed with the air from the primary slow air No. 2 bleeder. This air/fuel mixture is further blended with the air from the primary slow air No. 1 bleeder and air supplied through the mixture control solenoid. Then the air/fuel mixture passes through the idle down channel and enters the carburetor bore through the off idle discharge port and the idle discharge hole.

##### [Mixture control solenoid valve]

The primary system has the Mixture Control Solenoid (MCS) Valve. In the MCS, there is a plunger which makes 16 up and down movements per second by the electrical signals from the Electronic Control Module (ECM). That is, when an electrical signal is received by the solenoid, the plunger will move down and when no signal is received, the plunger will move up by the spring force.

When the plunger moves down, the air jet located on the upper side of the mixture control solenoid valve will open as shown in below figure, allowing the air to flow into the idle down channel. In this condition, the mixture will become lean.

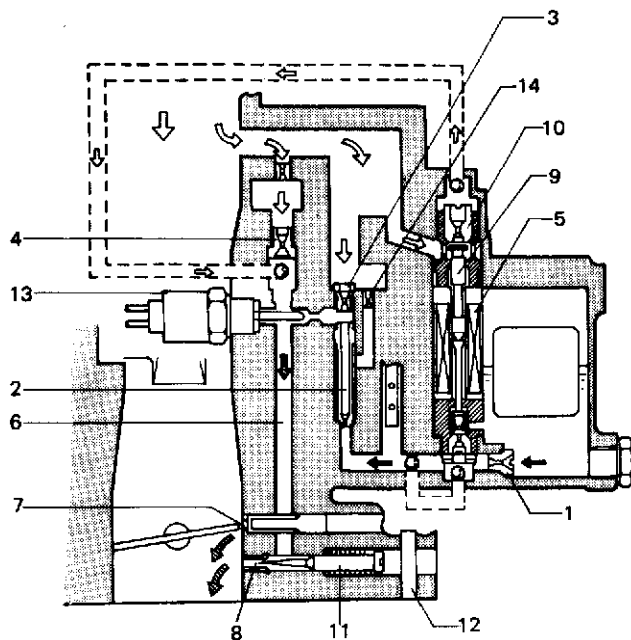
On the other hand, when the plunger is pushed up by the spring, the air jet will close, shutting off the air flow into the idle down channel. In this condition, the mixture will become rich.

The up and down movement of the plunger at the rate of 16 times per second to the signals from the ECM controls the air/fuel mixture to the optimum ratio at all times and as a result helps to improve the emission and engine performances, and fuel economy.

The ECM receives the electrical information from the oxygen sensor installed to the exhaust manifold and the engine operating condition signals from other devices and sends out and stops the electrical signal to the mixture control solenoid valve to actuate the plunger up and down 16 times every second. The ECM is located under the glove box of the instrument panel.



- Since the mixture control solenoid valve is factory adjusted, it must not be overhauled or its jets must not be removed.
- Since the mixture adjust screw is also factory adjusted, it must not be adjusted at the field except the following.
  - a. When the carburetor assembly has been replaced.
  - b. When the carburetor has been overhauled.
  - c. When the idle mixture adjustment is necessary due to the emission test failures.
 To adjust the mixture adjust screw in one of the above conditions, drive out the pin in front of the screw. After the adjustment, a new pin should be installed.

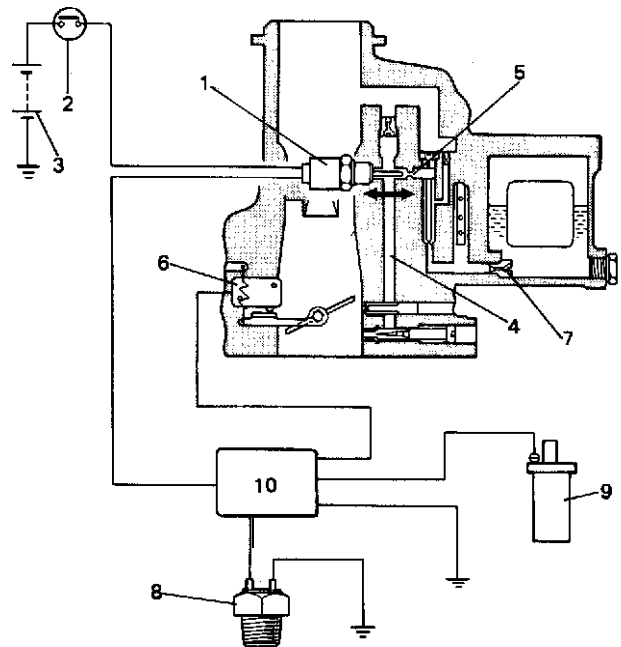


1. Primary main jet
2. Primary slow jet
3. Primary slow air No. 2 bleeder
4. Primary slow air No. 1 bleeder
5. Mixture control solenoid valve
6. Idle down channel
7. Off idle discharge port
8. Idle discharge hole
9. Plunger
10. Air jet
11. Mixture adjusting screw
12. Pin
13. Solenoid valve (Fuel cut)
14. Economizer air bleeder

Fig. 4- 1-5 Primary slow system

[Fuel cut system]

The primary slow system incorporates the fuel cut system with the fuel cut solenoid valve which is operated by the ignition switch and the ECM. When the ignition switch is at "OFF" position or during deceleration, the fuel cut solenoid valve stops the fuel flow into the idle down channel by closing the fuel passage. Thus the fuel cut system helps to prevent the dieseling and improve the emission performance and fuel economy. For details, refer to SECTION 5 "EMISSION CONTROL SYSTEM".



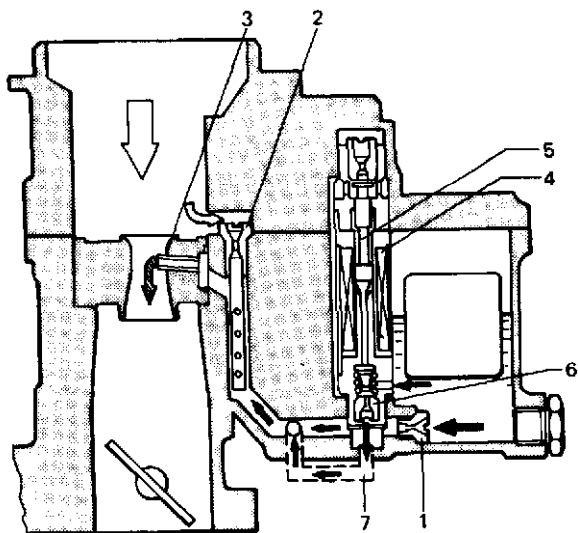
1. Fuel cut solenoid valve
2. Ignition switch
3. Battery
4. Idle down channel
5. Fuel passage
6. Idle micro switch
7. Primary main jet
8. Thermal switch
9. Ignition coil
10. ECM

Fig. 4-1-6 Fuel cut system

**[Primary main system]**

The fuel metered by the primary main jet is mixed with the air from the primary main air bleeder and then is discharged into the carburetor bore through the main discharge nozzle. When the plunger of the MCS is at the up position (i.e. the ECM electrical signal is not received by the MCS), the fuel orifice of the MCS is open. In this state, the fuel is allowed to flow into the fuel passage through this orifice in addition to the main jet and the mixture becomes rich.

On the other hand, when the plunger is at the down position (i.e. the ECM signal is received by the MCS), the fuel orifice is closed. In this state, the fuel flows into the fuel passage only through the main jet and therefore the mixture becomes lean. In this way, the mixture is maintained to the optimum air/fuel ratio at all times by the plunger which moves up and down at a frequency of 16 times per second according to the electrical signals from the ECM.



- 1. Primary main jet
- 2. Primary main air bleeder
- 3. Main discharge nozzle
- 4. Mixture control solenoid valve
- 5. Plunger
- 6. Fuel orifice
- 7. Fuel passage

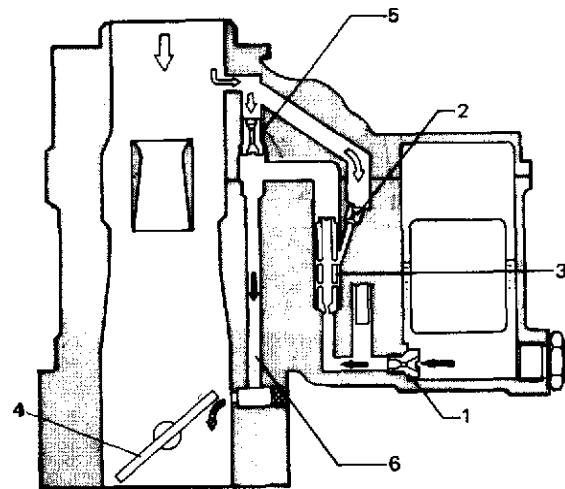
**Fig. 4- 1-7 Primary main system**

**Secondary System**

**[Secondary slow system]**

This system operates during the transition period from the primary main system to the secondary main system. When the primary throttle valve is open nearly 54° and the vacuum in "A" as shown in the below figure exceeds specification, the diaphragm pulls up the rod.

In this state, the secondary throttle valve is ready to open at any time when the primary throttle valve opens further. When the secondary throttle valve opens, the fuel discharged through the secondary main jet is mixed with the air from the economizer air bleeder at the secondary slow jet. Then it is further blended with the air from the secondary slow air bleeder and enters into the carburetor bore through the idle down channel.



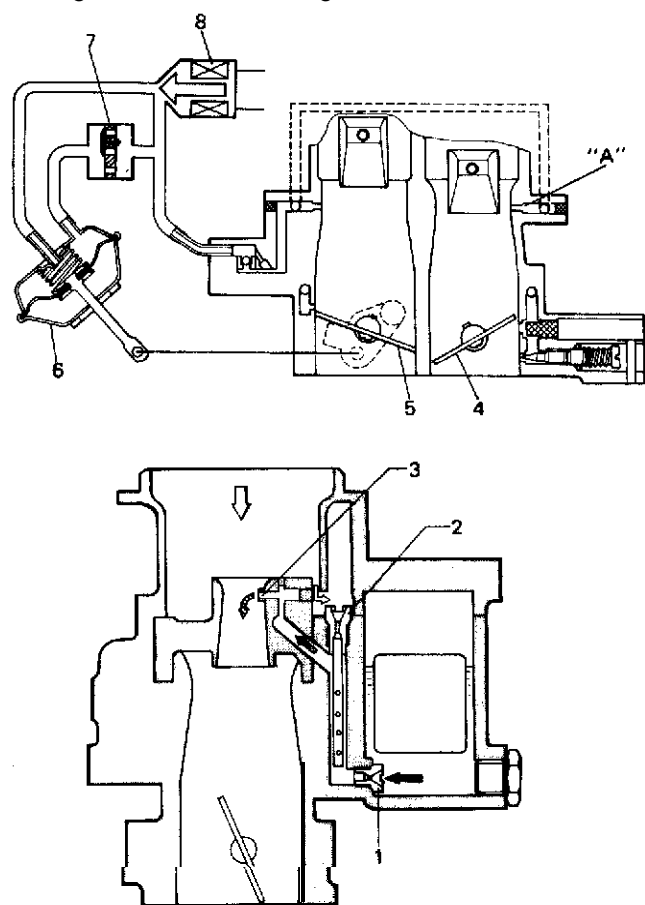
- 1. Secondary main jet
- 2. Economizer air bleeder
- 3. Secondary slow jet
- 4. Secondary throttle valve
- 5. Secondary slow air bleeder
- 6. Idle down channel

**Fig. 4-I-8 Secondary slow system**

**[Secondary main system]**

Operation of the secondary throttle valve is also controlled by the VTV and VSV. When the VSV is closed, the vacuum to be applied to the secondary diaphragm passes the VTV side and the secondary throttle valve opens gradually.

When the primary throttle valve opens almost fully, the VSV opens according to the signal from the ECM. Then the vacuum is applied directly to the secondary diaphragm and the secondary throttle valve responds to intensity of vacuum. When the secondary throttle valve opening is wider than when secondary slow system operates, the fuel is discharged through the secondary main jet and mixed with the air from the secondary main air bleeder. The air/fuel mixture is discharged into the carburetor bore through the main discharge hole.



- 1. Secondary main jet
- 2. Secondary main air bleeder
- 3. Main discharge hole
- 4. Primary throttle valve
- 5. Secondary throttle valve
- 6. Secondary diaphragm
- 7. VTV
- 8. VSV

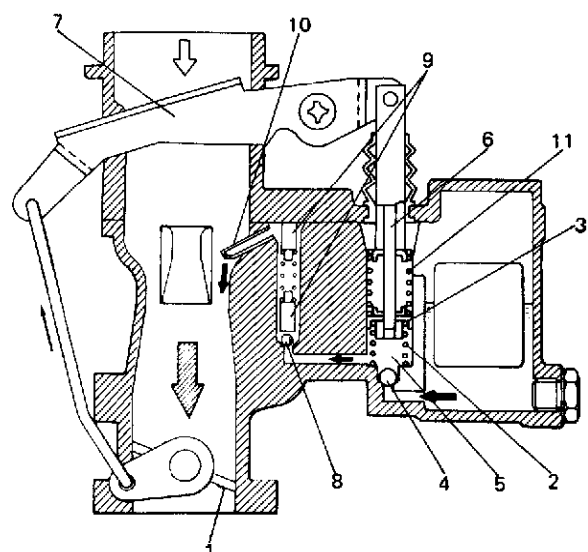
**Fig. 4-1-9 Secondary main system**

**Acceleration Pump System**

This system operates to supply extra fuel to the primary side only during the acceleration.

When the primary throttle valve closes, the return spring pushes up the pump piston. Then the fuel pushes up the check ball and enters into the pump cylinder. When the throttle valve opens during the acceleration, simultaneously the pump piston is pushed down by means of the pump lever. Then the fuel in the pump cylinder pushes up the discharge ball and the lower injector weight and discharges into the carburetor bore from the pump discharge nozzle.

In this way, a higher acceleration performance is provided by this system.



- 1. Primary throttle valve
- 2. Return spring
- 3. Pump piston
- 4. Check ball
- 6. Pump cylinder
- 6. Plunger
- 7. Pump lever
- 8. Discharge ball
- 9. Injector weight
- 10. Pump discharge nozzle
- 11. Pump damper spring

**Fig. 4-1- 10 Acceleration pump system**

## Choke System

This choke system is provided with a thermo-wax which operates according to the heat from the engine coolant, causing the choke valve to open and close as well as the fast idle system to operate automatically.

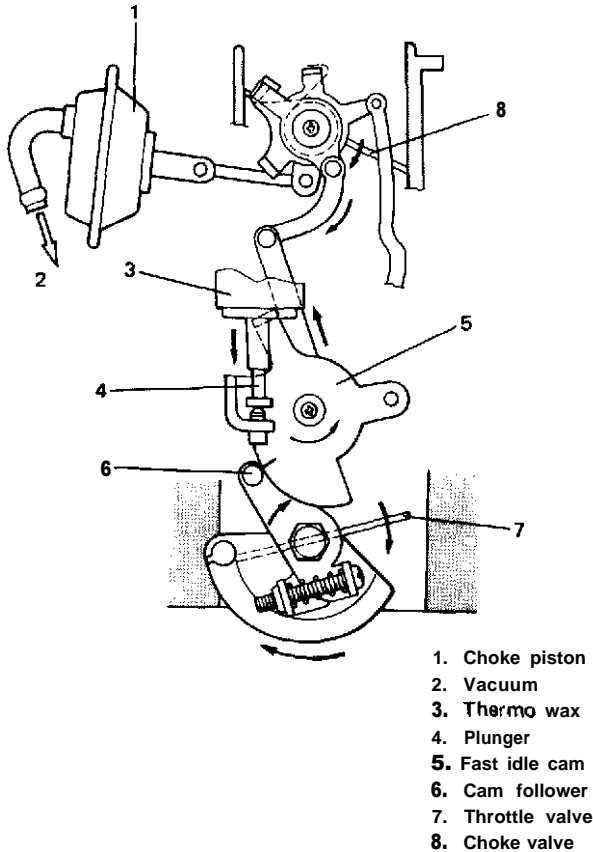


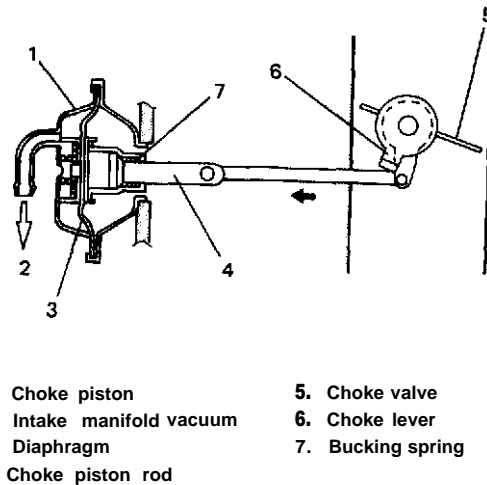
Fig. 4-1-11 Choke system

### [Operation of choke system]

As the thermo-wax is contracted at the low coolant temperature, the plunger of the thermo-wax is retracted (at the up position) and the fast idle cam rotates clockwise by the spring force. As a result, the cam follower pushed down by the cam causes the primary throttle valve to open and brings about the fast idle state. The thermo-wax expands as the coolant temperature rises and the plunger position lowers, causing the fast idle cam to rotate counterclockwise. As a result, the throttle valve starts moving to close. In this way, the throttle valve closes gradually as the coolant temperature rises until it reaches the idling position at the normal temperature. Refer to Fig. 4-1-11.

### 1) When coolant temperature is low:

As the thermo-wax is contracted and the plunger is retracted, the choke valve linked with the fast idle cam is closed. When the engine is started in this state, the intake manifold vacuum pulls the diaphragm of the choke piston to the left (below figure). The choke piston rod also moves to the left and acts on the choke valve to open. However, the choke valve is restricted by the plunger of the thermo-wax through the choke lever. Therefore, the rod cannot move to the left far enough to open the choke valve wide and has to stop at a position where the choke valve opening is small as shown in the figure. In this state, the diaphragm contracts the bucking spring.



- |                           |                   |
|---------------------------|-------------------|
| 1. Choke piston           | 5. Choke valve    |
| 2. Intake manifold vacuum | 6. Choke lever    |
| 3. Diaphragm              | 7. Bucking spring |
| 4. Choke piston rod       |                   |

Fig. 4-1-12 When coolant temp. is low

### 2) When the coolant temperature rises:

The plunger lowers due to the expansion of the thermo-wax. Then the fast idle cam rotates counterclockwise and consequently the choke lever clockwise. This allow the rod to move further to the left by the bucking spring force (below figure). Thus a wide opening of the choke valve is obtained.

Hereafter, the plunger of the thermo-wax moves futher down in accordance with the coolant temperature rise. The lower the plunger moves, the wider the choke valve opening becomes, and it becomes fully open at the normal coolant temperature.

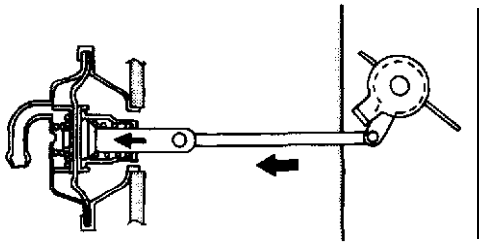


Fig. 4-1- 13 When coolant temp. rises

**[Unloader system]**

If accelerator pedal is depressed for acceleration while the opening of the choke valve is small, the throttle lever pulls down the unloader lever and the choke valve opens up temporarily for smooth acceleration.

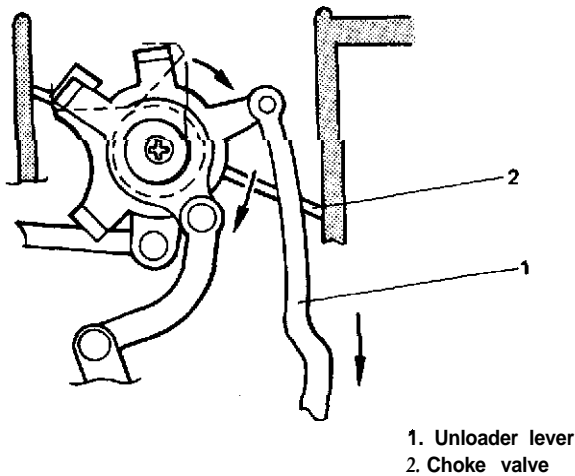


Fig. 4-1-14 Unloader system

**Idle Up System**

This system operates at idling and compensates the idle speed;

- 1) When any one of following electric loads is operating.
  - Small light, tail light, side marker light & license light
  - Rear defogger (if equipped)
  - Heater fan

- 2) When car is at a high altitude (higher than 1,220 m (4,000 ft) and HAC is ON).
- 3) When temperature in engine room is cold (below 7°C (44°F) and thermal switch is ON).
- 4) When engine speed after engine start is lower than 1,500 r/min.

The ECM sends an electric signal to the Three Way Solenoid Valve (TWSV). Receiving the signal, the TWSV opens its inner valve and transmits the manifold vacuum to the idle-up diaphragm. As the diaphragm moves down by the vacuum, the rod move down and push the throttle lever to open the throttle valve a little for the idle-up state.

In this way, the idle-up system helps to stabilize the idle speed even when electric loads operate. When electric loads stop operating, the TWSV closes. Then the idle-up diaphragm as well as rod moves back up, thus the idle-up state is released.

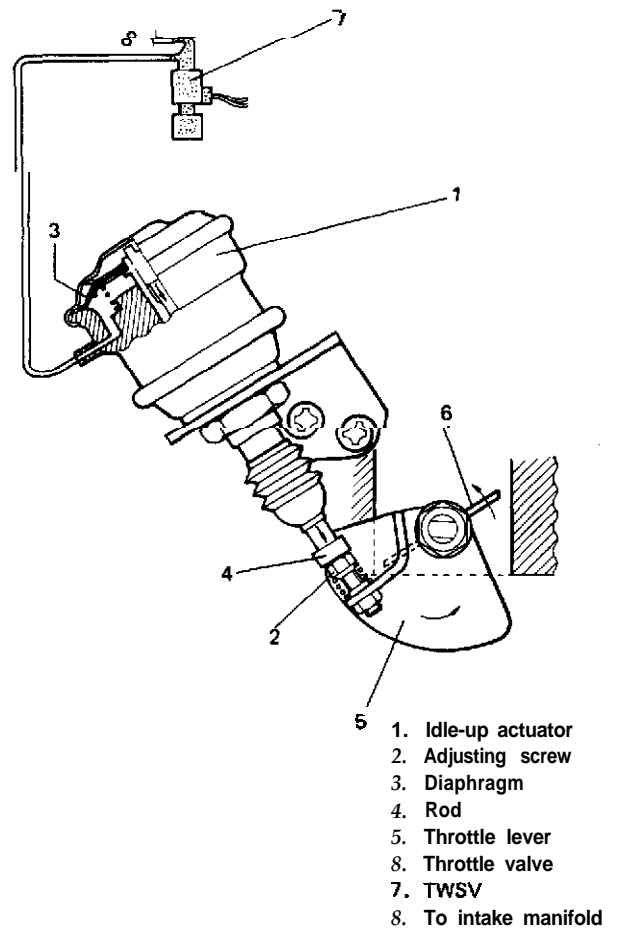


Fig. 4-1- 15 Idle-up system operation

## REMOVAL AND INSTALLATION

### WARNING:

Removal and installation of carburetor must be carried out in a well-ventilated place where no fire is used around.

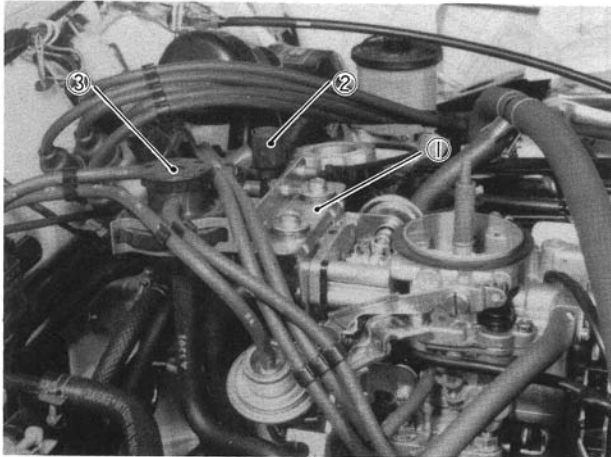
### Removal

- 1) Disconnect negative battery cord from battery.
- 2) Drain coolant.

### WARNING:

To help avoid the danger of being burned, do not remove the drain plug and the radiator cap while the engine and radiator are still hot. Scalding fluid and steam can be blown out under pressure if the plug and cap are taken off too soon.

- 3) Remove air intake case from carburetor.
- 4) Disconnect micro switches, switch vent solenoid valve, fuel cut solenoid valve and MCSV lead wires at their couplers.
- 5) Disconnect VSV coupler from VSV.
- 6) Detach bracket with EGR modulator and TWSV from carburetor.



1. Bracket
2. Twsv
3. EGR modulator

Fig. 4- 1- 16

- 7) Disconnect water inlet and outlet hoses from carburetor.
- 8) Disconnect accelerator cable from carburetor.

- 9) Disconnect vacuum hoses from idle up actuator and carburetor.
- 10) To release the pressure in fuel tank, remove fuel tank filler cap and then, reinstall it.
- 11) Disconnect fuel inlet hose from carburetor.
- 12) Check all around carburetor for any other parts required to be removed or disconnected for removal of carburetor and remove or disconnect whatever necessary.
- 13) Remove carburetor from intake manifold.

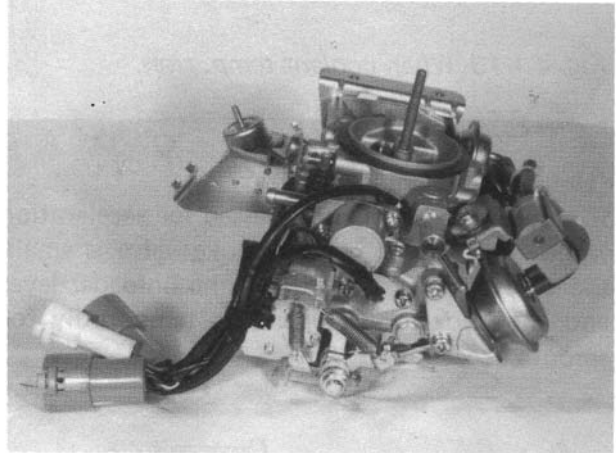


Fig. 4-1- 17

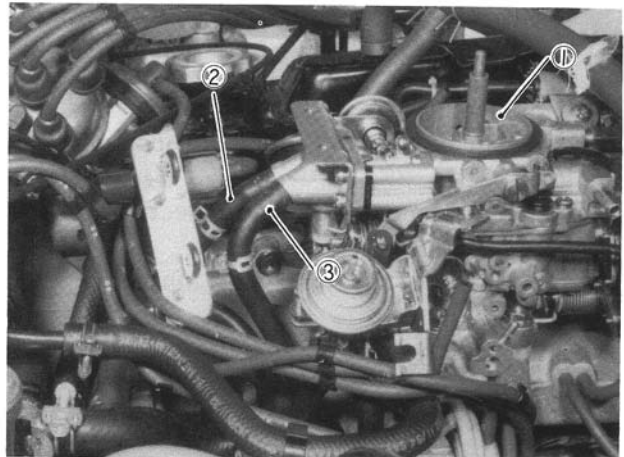
### Installation

Install in the reverse order of removal using care for the following.

- Install carburetor to intake manifold. Tighten 4 carburetor nuts to the specified torque.

Tightening torque for nuts	18 – 28 N·m
	1.8 – 2.8 kg·m
	13.5 – 20.0 lb·ft

- Connect water hoses to carburetor.



1. Carburetor
2. Inlet hose
3. Outlet hose

Fig. 4-1- 18

- Connect electric couplers securely.
- Connect accelerator cable to carburetor. With the accelerator pedal released, adjust the cable play to specification. This adjustment can be made by turning the adjusting nut. After adjustment, tighten the lock nut. Refer to p. 4-19.
- Connect vacuum hoses securely.
- Refill cooling system.
- Connect negative cable at battery.

**NOTE:**

Upon completion of installation, be sure to check each part for evidence of fuel leakage and for proper operation. If defective, correct.

**UNIT REPAIR OVERHAUL**

This section outlines procedure to be used for overhauling carburetor as removed from engine. For removal and installation of carburetor from and to engine, refer to the previous page.

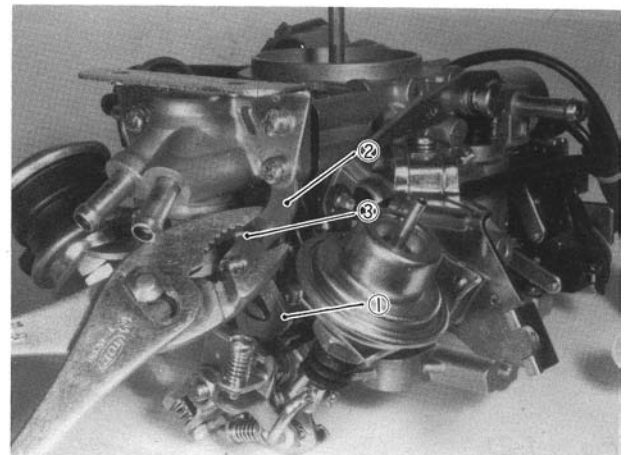
**NOTE:**

- Be sure to replace gaskets as well as worn or damaged parts.
- While disassembling and assembling carburetor, use special care not to deform levers on throttle valve shaft or cause damage to any other parts.
- Don't disassemble mixture control solenoid valve and accelerator pump piston.
- Don't remove idle and wide open micro switches from the bracket where they are installed.

**WARNING:**  
Keep lighted cigarette and any other fire off near carburetor as it contains gasoline, when servicing carburetor.

**Disassembly**

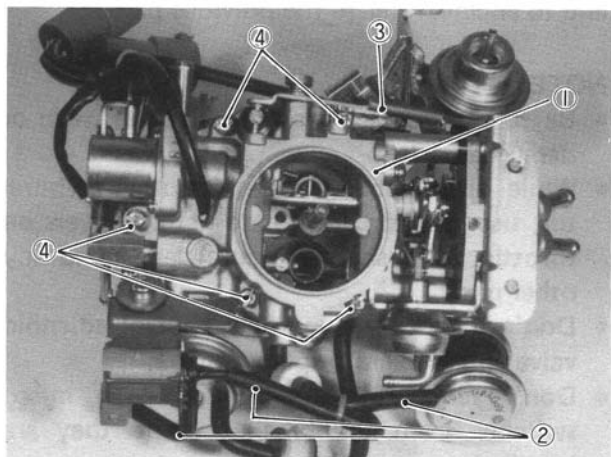
- 1) Turn fast idle cam counterclockwise and insert a pin available into holes on cam and bracket to lock the cam.



1. Fast idle cam      3. Pin  
2. Bracket

**Fig. 4-1- 19**

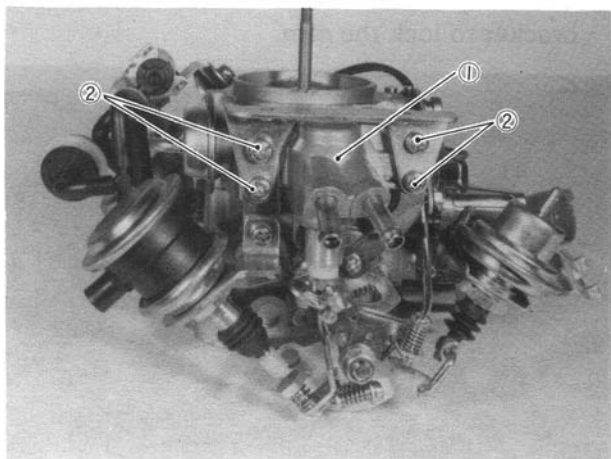
2) Remove air horn from float chamber after disconnecting three hoses and pump lever and removing five screws of air horn. Loosen idle up bracket screw.



- 1. Air horn
- 2. Hose
- 3. Pump lever
- 4. Screw

**Fig. 4- I-20 Air horn and hoses, etc.**

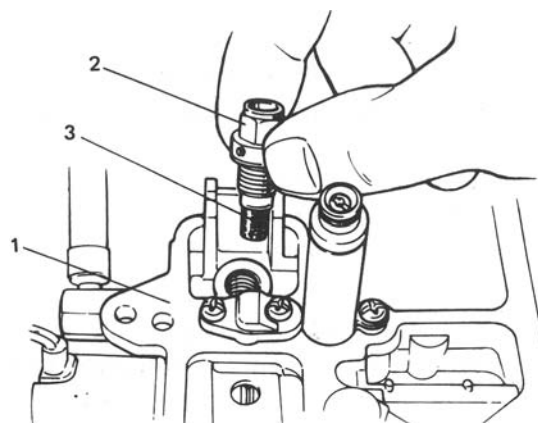
**NOTE:**  
Never loosen 4 screws fixing element holder at this point.



- 1. Thermo element holder
- 2. Screw

**Fig. 4-I-21**

3) Remove float and needle valve from air horn and then needle valve seat and filter.

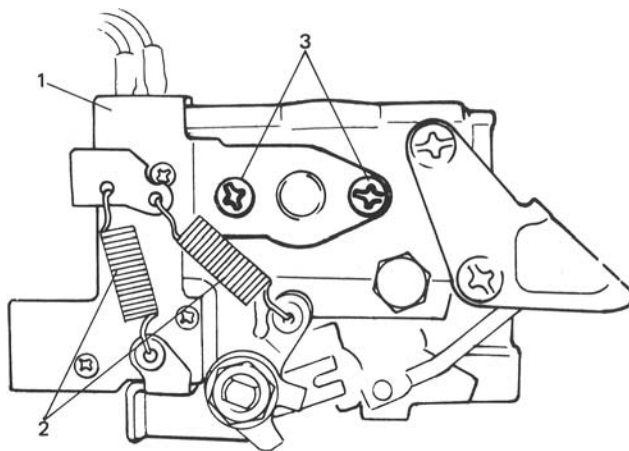


- 1. Air horn
- 2. Needle valve seat
- 3. Needle valve filter

**Fig. 4- I-22 Needle valve seat and filter**

4) Remove micro switch bracket after removing 2 springs and 2 screws indicated in below figure.

**NOTE:**  
Don't remove micro switches from bracket.

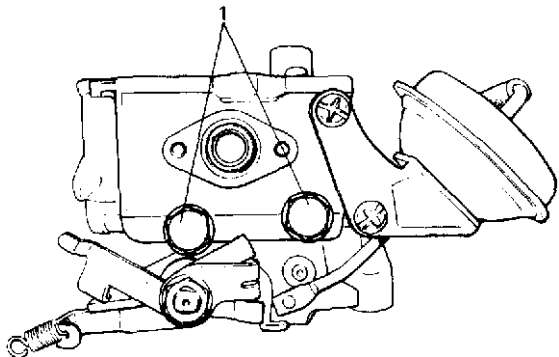


- 1. Micro switch bracket
- 2. Spring
- 3. Screw

**Fig. 4-1-23 Idle and wide open micro switches and bracket**



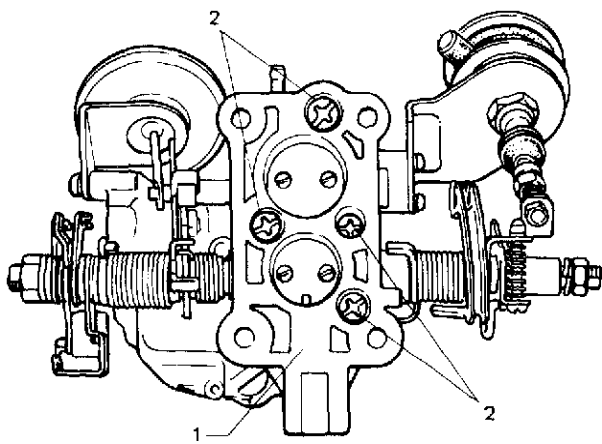
- 5) Remove two drain plugs and then primary and secondary main jets in float chamber through plug's holes, using a negative screw driver.



1. Drain plug

**Fig. 4- I-24 Drain plugs**

- 6) Remove throttle chamber from float chamber after removing four screws shown in below figure.



1. Throttle chamber  
2. Screw

**Fig. 4- I-25 Throttle chamber**

#### Cleaning

- 1) Wash below listed items in carburetor cleaner and then clean them by blowing compressed air.
  - All removable air jets and fuel jets, except mixture control solenoid valve jet.
  - Needle valve, valve seat and filter.

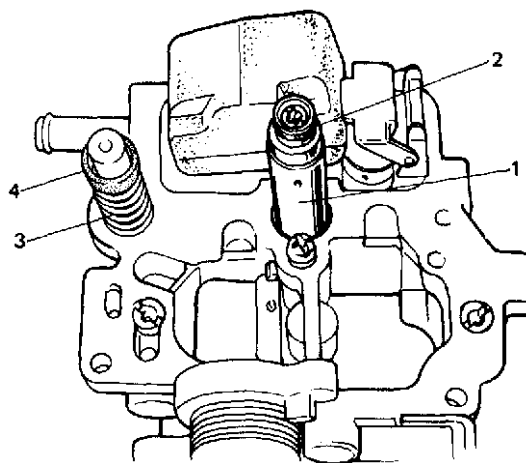
- 2) Blow compressed air into all passages to clean.
- 3) Clean bottom of float chamber.

#### NOTE:

- 1) Don't immerse following parts in carburetor cleaner.
  - Micro switches (wide open switch and idle switch)
  - Switch vent solenoid
  - Fuel cut solenoid valve
  - Mixture control solenoid valve
  - Secondary diaphragm, choke piston and idle-up actuator
  - Parts made of rubber or resin and gasket
  - Thermo-wax (thermo element)
- 2) Don't put drills or wires into fuel passages and metering jets for cleaning. It causes damages in passages and jets.
- 3) If cleaning solvent contacts rubber or resin parts, be sure to blow off cleaning solvent by compressed air immediately.

#### Inspection

- 1) Check choke valve and throttle valves for smooth operation.
- 2) Check rubber cup of pump piston and seal of mixture control solenoid valve for deterioration and damage. Refer to below figure.
- 3) Check needle valve and valve seat for wear.

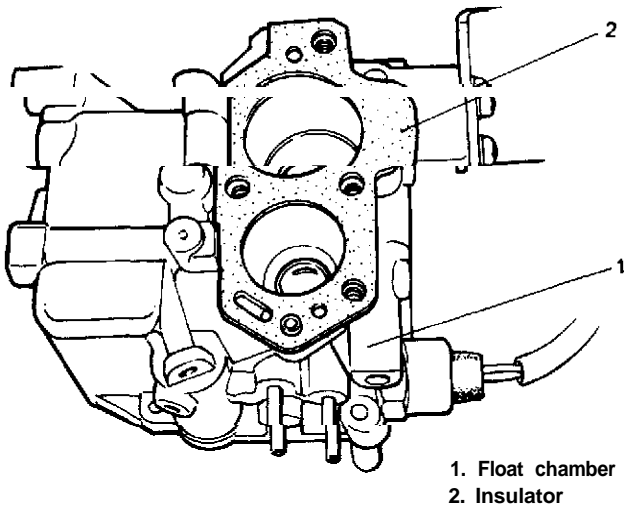


1. Mixture control solenoid valve  
2. seal  
3. Spring  
4. Rubber cup

**Fig. 4- I-26 Accelerator pump piston and mixture control solenoid valve**

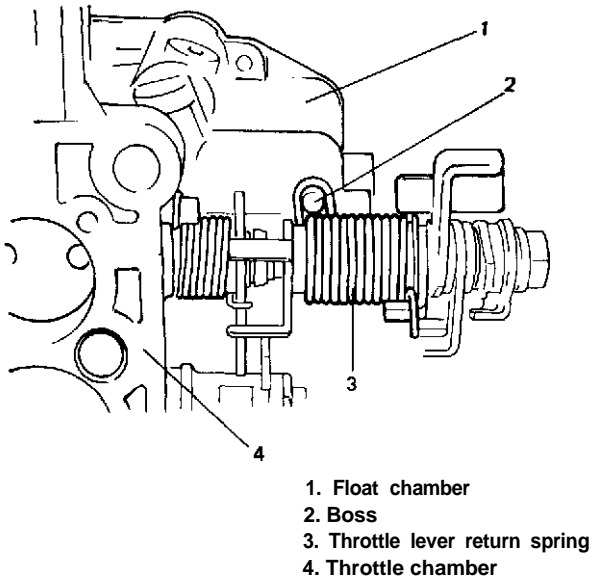
**Assembly**

1) Install insulator to float chamber as shown in below figure.



**Fig. 4-1-27 Insula tor installation**

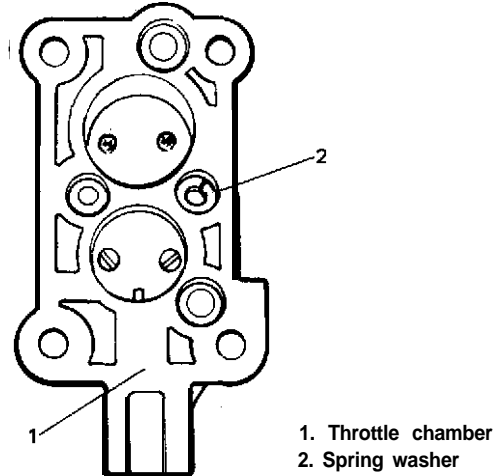
2) After attaching both ends of throttle lever return spring as shown in figure, install throttle chamber to float chamber. Hook throttle valve side end of return spring over the boss on float chamber as shown in below figure.



**Fig. 4- I-28 Hooking throttle lever return spring**

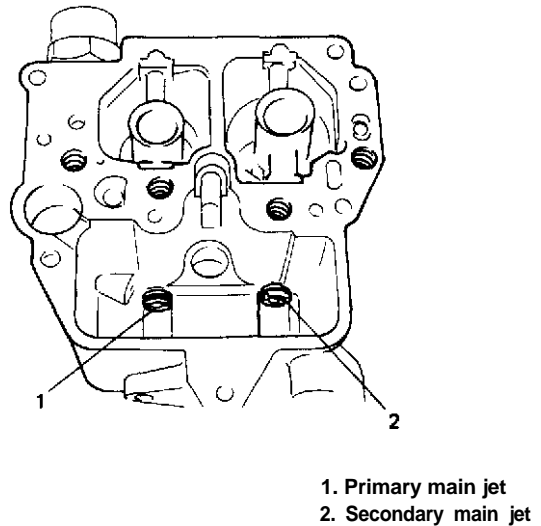
3) Install spring washer as below figure, and torque four screws to specification.

Tightening torque for screws	4 - 7 N·m 0.4 - 0.7 kg·m 3 - 5 lb·ft
------------------------------	--



**Fig. 4- I-29 Installing washer**

4) Install primary and secondary main jets.



**Fig. 4-I-30 Primary and secondary main jets**

5) Install gaskets and drain plugs, after installing main jets.

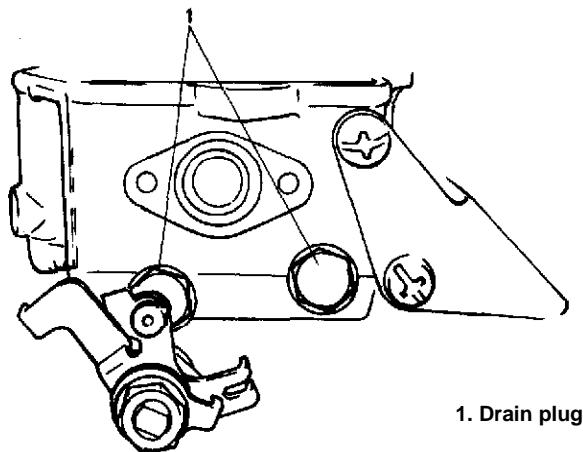


Fig. 4- I-3 1 Installing drain plugs

6) Install level gauge seal.

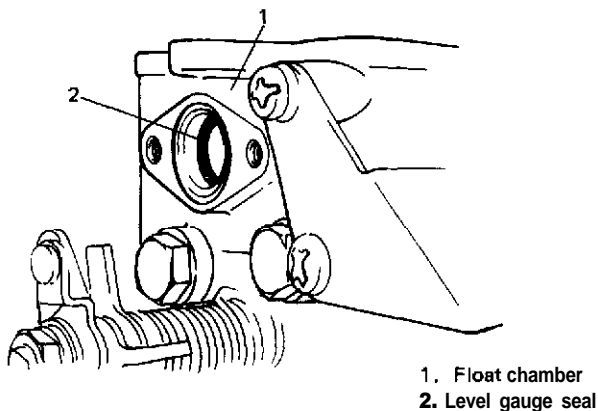


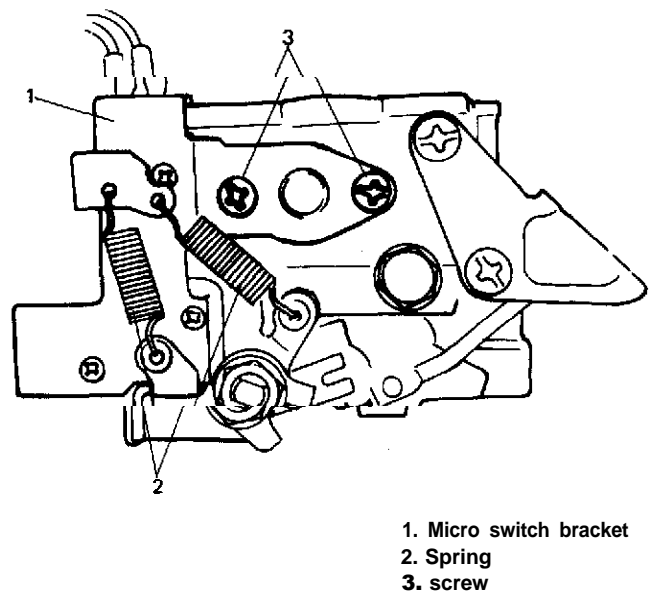
Fig. 4-I-32 Installing level gauge seal

7) install micro switch bracket with micro switches and level gauge, and two springs as shown in below figure.

**NOTE:**

- Don't remove micro switches (idle switch & wide open switch) from bracket.
- When bracket with micro switches has been removed from float chamber for any service and reinstalled after service work, make sure to check switches for operation and adjust if necessary. Check and adjustment for micro switches should be carried out with carburetor removed from intake manifold.

Refer to SECTION 5 "EMISSION CONTROL SYSTEM" for procedure to check and adjust micro switches.



Fig, 4- I-33 Ins talling bracket and springs

8) Install jets and air bleeders to float chamber. Refer to Fig. 4-I -34 for their installation.

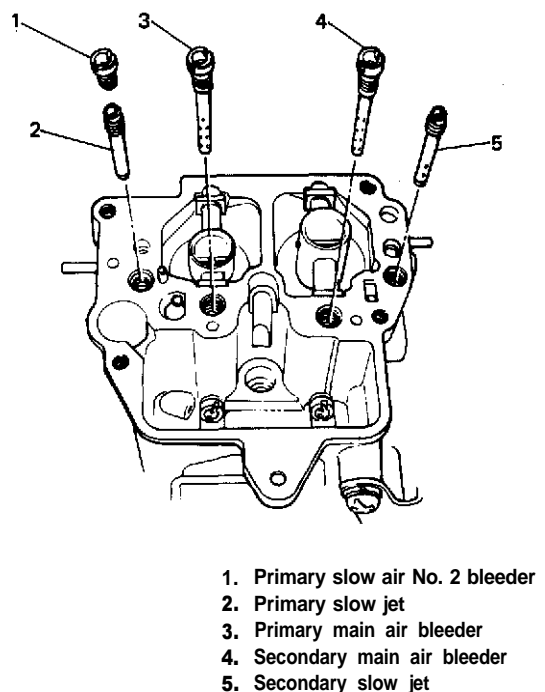


Fig. 4-1-34 Installing jets and air bleeders

9) Install balls, injector spring and weights to accelerator pump. Direct "U" bent end side of piston return spring downward as shown in below figure.

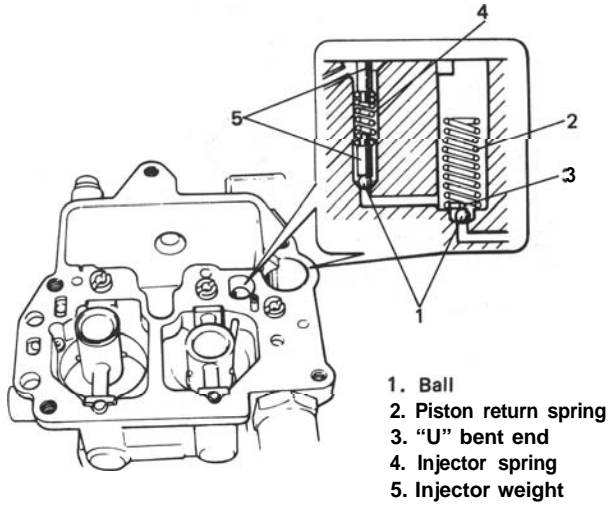


Fig. 4-1-35 Installing balls, injector spring and weights, and piston return spring

10) Install needle valve filter, valve seat, gasket, needle valve and float to air horn. After installing float, check for float level and adjust if necessary.  
 11) Install primary and secondary slow air bleeders to air horn.

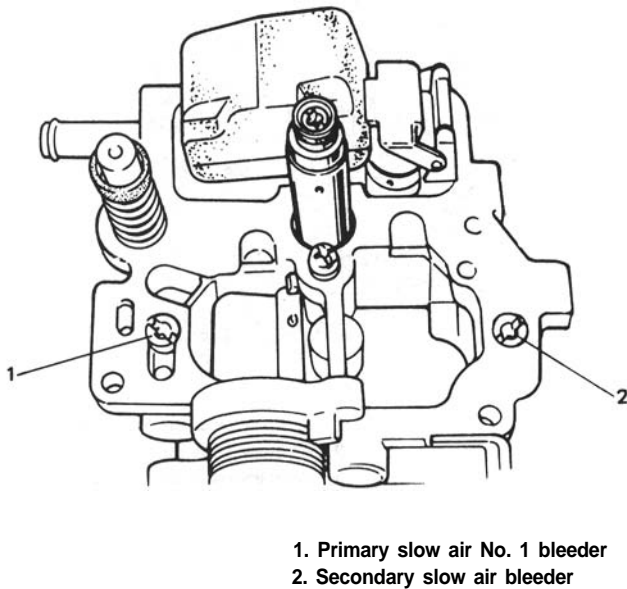


Fig. 4-1-36 Installing slow air bleeders

12) Be sure to apply silicone oil to mixture control solenoid valve seal before installing air horn to float chamber.

**NOTE:**

Be sure to use silicone oil that will not affect rubber.

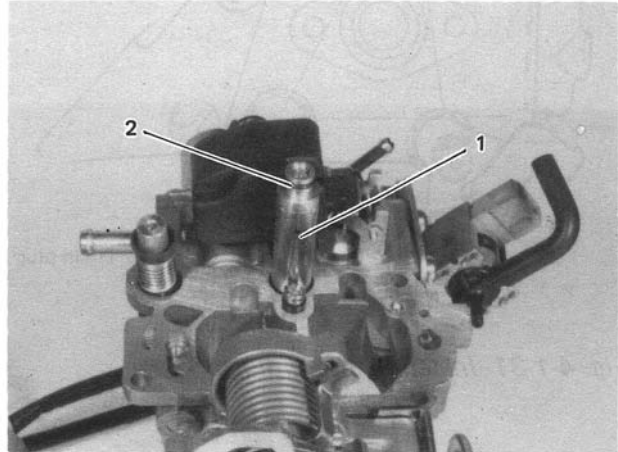


Fig. 4-1-37 Mixture control solenoid valve seal

13) Install air horn gasket to float chamber. Use new gasket.  
 14) Install air horn to float chamber. After installing acceleration pump lever to air horn, check lever for smooth operation.  
 15) Connect 3 hoses as shown below figure.

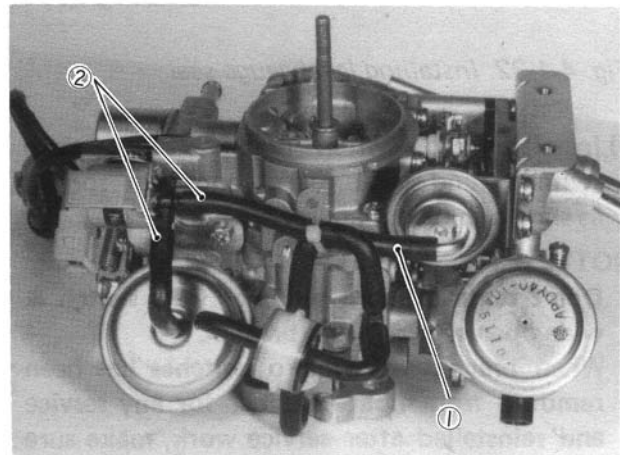
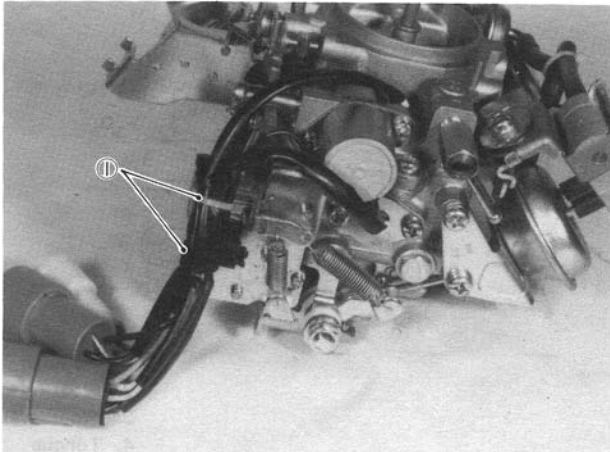


Fig. 4-1-38 Installing hoses

16) Clamp wire harness securely.



1. Clamp

Fig. 4- I-39

17) Remove the pin installed before disassembly (to lock fast idle cam).



Fig. 4-1-40

## MAINTENANCE SERVICES

Before checking or adjusting the carburetor as the cause of poor engine performance or rough idle, check the followings for malconditions.

- Ignition system including distributor, timing, spark plugs and wires.
- Air cleaner including thermostatically controlled air cleaner system.
- Evaporative emission control system.
- PCV system.
- EG R valve.
- Engine compression.

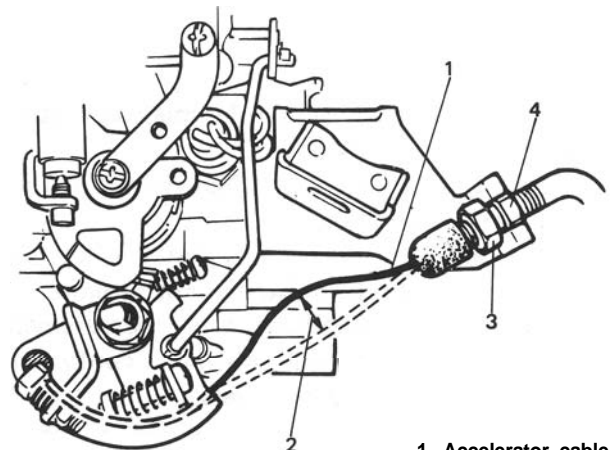
Also, check the intake manifold, carburetor and vacuum hoses for leakage.

### Accelerator Cable Adjustment

Check accelerator cable for play and adjust if necessary.

Cable play should be within the specifications. If out of specification, loosen lock nut and adjust by turning adjusting nut. Be sure to tighten lock nut securely after adjustment.

Condition	Cable play
When carburetor and coolant are cold;	10 – 15 mm (0.4 – 0.6 in.)
When carburetor and coolant are warm;	3 - 5 m m (0.12 – 0.20 in.)

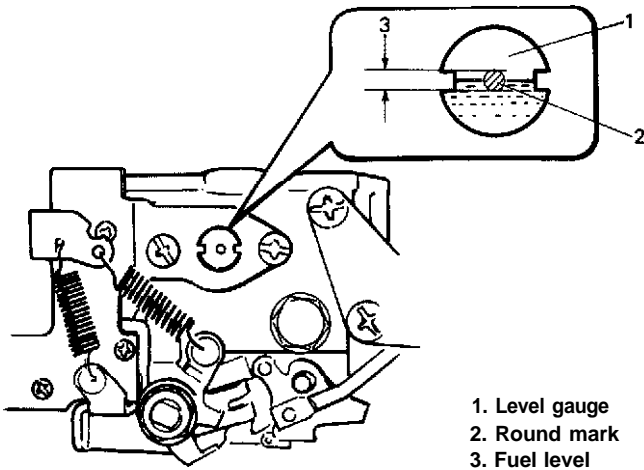


1. Accelerator cable
2. Cable play
3. Lock nut
4. Adjusting nut

Fig. 4- I-41 Accelerator cable play

## Float Adjustment

1) The fuel level in float chamber should be within round mark at the center of level gauge.



1. Level gauge  
2. Round mark  
3. Fuel level

Fig. 4-1-42 Fuel level

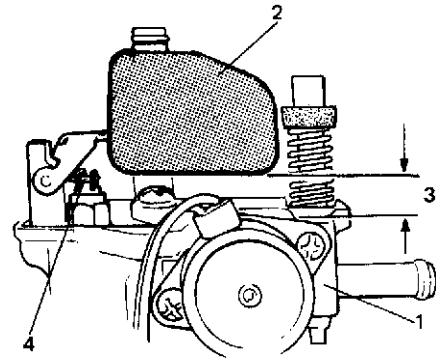
2) If the fuel level is not found within the round mark, check the float level and adjust it as follows:

- a) Remove the air horn, and invert it.
- b) Measure the distance between the float and the gasketed surface of air horn. The measured distance is float level, and it should be the specification.  
If the float level is out of specification, adjust it by bending the tongue up or down.

### NOTE:

- This measurement should be made without a gasket on the air horn.
- Check float height with float weight applied to needle valve.
- As a gauge for checking float level, use something whose thickness measurement is the same as specified level measurement (such as a drill or M8 bolt) after confirming thickness with vernier calipers.

Float level specification	8mm (0.31 in.)
---------------------------	-------------------

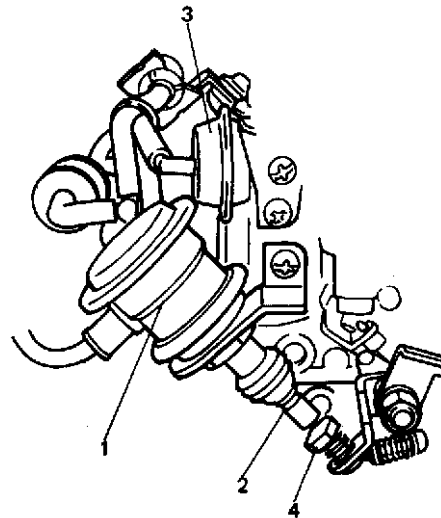


1. Air horn  
2. Float  
3. Float level  
4. Tongue

Fig. 4-1-43 Float level

## Idle Up Adjustment

- 1) Warm up engine to normal operating temperature.
- 2) Check to be sure that engine idle speed is specification.
- 3) Check to ensure that idle-up actuator rod moves down (indicating that idle-up is at work) when small light, tail light, license light and side marker light are turned "ON".



1. Idle-up actuator  
2. Idle-up actuator rod  
3. Choke piston  
4. Idle up adjusting screw

Fig. 4-1-44 Idle-up adjusting screw

- 4) With lights (head light) turned "ON", check engine rpm (idle-up speed). Be sure that heater fan, rear defogger (if equipped), and air conditioner (if equipped) are all turned "OFF".

Idle-up speed	900 – 1,000 r/min.
---------------	--------------------

If idle-up speed is not within specification, adjust by turning adjusting screw.

- 5) After idle-up adjustment, check to ensure that idle-up adjusting screw moves as in step 3) when only heater fan is operated and then only rear defogger is operated (small light, tail light, side marker light and license light should be "OFF" in this cases).

If found faulty in step 3), check following parts individually according to each procedure.

#### [Checking TWSV]

- 1) Make sure that lighting switch, heater fan switch, rear defogger switch (if equipped) and air conditioner switch (if equipped) are all turned OFF.
- 2) Disconnect TWSV vacuum hoses from intake manifold and actuator.
- 3) With ignition switch at "OFF" position, by blowing air into hose disconnected from actuator, make sure there is no continuity between these hoses.
- 4) Turn lighting switch to ON position and by blowing air into the hose disconnected from actuator, make sure that there is continuity between hoses.



1. TWSV (Black)                      3. To actuator  
2. To intake manifold

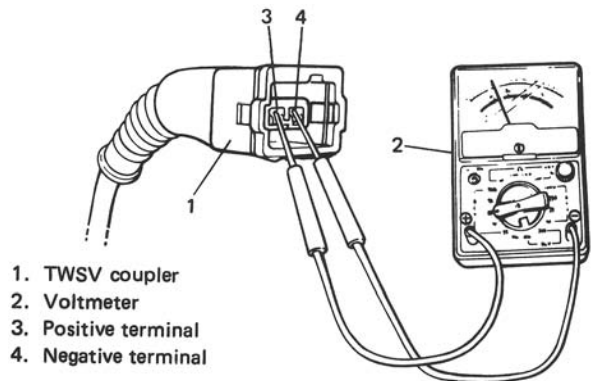
**Fig. 4- I-45**

If defective in steps 3) and 4), replace TWSV or checking TWSV circuit.

#### [Checking TWSV circuit]

- 1) Warm up engine to normal operating temperature.
- 2) Stop engine and disconnect TWSV coupler.
- 3) Run engine at idle speed and connect voltmeter to coupler terminals disconnected. Check that voltmeter indicates OV.
- 4) Check that voltmeter indicates about 12V under either of the following conditions.
  - When engine speed exceeds 2,000 r/min.
  - When lighting switch, heater fan switch or rear defogger switch (if equipped) is turned ON.

If defective in steps 3) and 4), the particular circuit is disconnected or in poor contact. Check the circuit for such condition. For detail, refer to item "CHECKING IDLE UP SIGNAL" in SECTION 5 "EMISSION CONTROL SYSTEM".

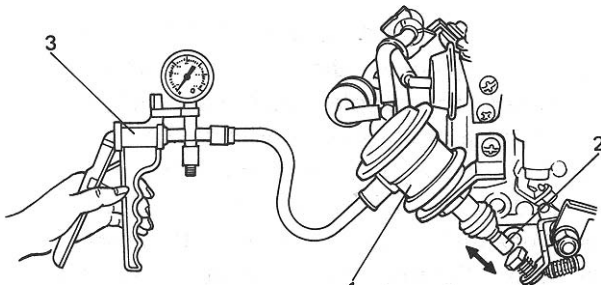


**Fig. 4-1-46**

#### [Checking actuator]

- 1) Disconnect hose from TWSV.
- 2) Connect special tool (vacuum pump gauge) to its hose,
- 3) Check that actuator rod moves smoothly and that it is held at the same position when about 40 cmHg vacuum is applied to actuator.

If rod doesn't move smoothly, or it isn't held at the same position, replace actuator.



1. Idle up actuator
2. Rod
3. Special tool (Vacuum pump gauge 09917-47910)

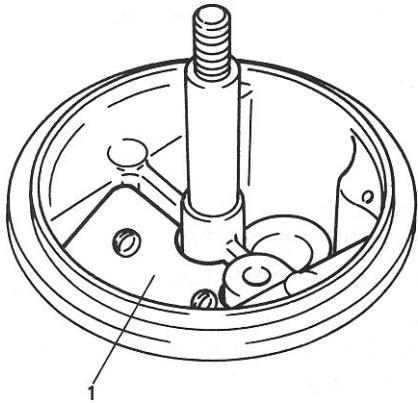
**Fig. 4-I-47**

### Choke Adjustment

Perform following check and adjustments with air intake case removed when engine is cold.

[Choke valve]

- 1) Check choke valve for smooth movement by pushing it with a finger.



1. Choke valve

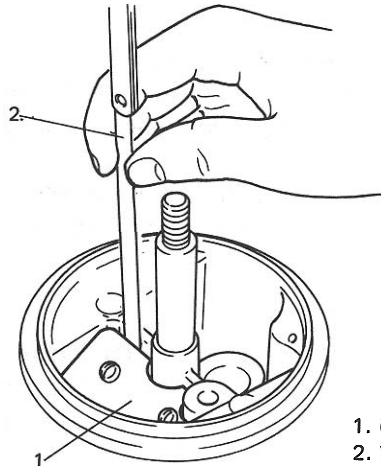
**Fig. 4-I-48 Choke valve**

- 2) Make sure that choke valve is closed almost completely when ambient temperature is below 25°C (77° F) and engine is cold.
- 3) Check to ensure that choke valve to carburetor bore clearance is within following specifications when engine is cool.

Ambient temperature	Clearance
25° C (77° F)	0.1 – 0.6 mm (0.004 – 0.023 in.)
40° C (104° F)	1.3 – 2.8 mm (0.05 – 0.11 in.)

### NOTE:

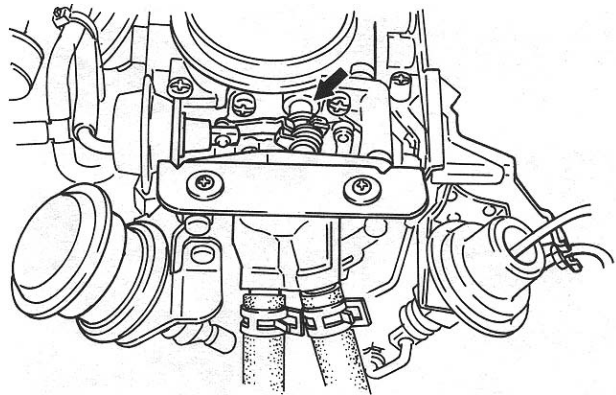
As ambient temperature or engine coolant temperature rises high, clearance increases.



1. Choke valve
2. Thickness gauge

**Fig. 4- 149 Choke valve to carburetor bore clearance**

- 4) If clearance is found excessively large or small in the above check, check strangler spring, choke piston and each link in choke system for smooth operation. Lubricate choke valve shaft and each link with spray lubricant if necessary.



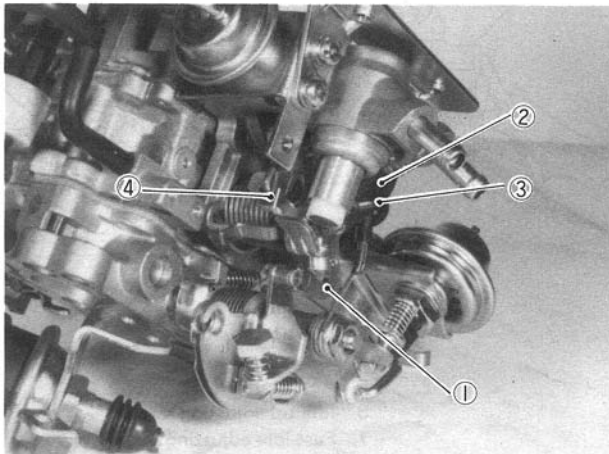
**Fig. 4-I-50**



5) If clearance is still out of specification even after lubrication in step 4), remove carburetor from intake manifold and remove idle-up actuator from carburetor.

Then, turn fast idle cam counterclockwise and insert a pin available into holes in cam and bracket to lock the cam.

In this state, bend choke lever shown in below figure up or down, with plier. Bending up causes choke valve to close, and down to open.

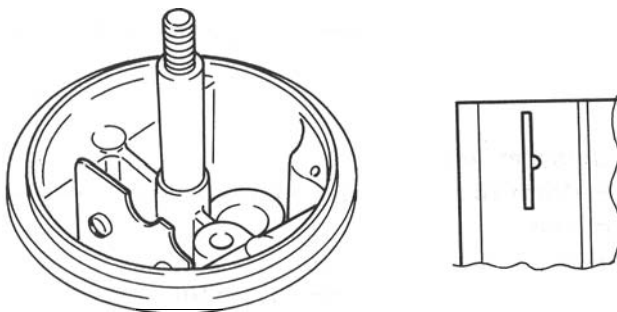


1. Fast idle cam 3. Pin  
2. Bracket 4. Choke lever

**Fig. 4-1-51 Choke lever**

6) After installing air intake case, start engine again and warm it up fully.

7) Stop the engine when it is warmed up and remove air intake case again, and then check to ensure that choke valve is fully open.



**Fig. 4- 1-52**

If choke valve doesn't open fully, defect lies in wax-element or its link system.

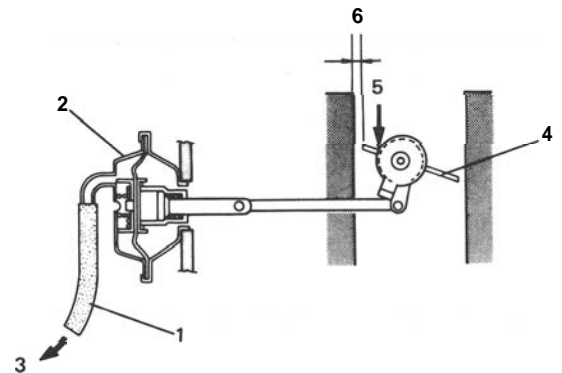
Repair or replace defective part(s).

**[Choke piston]**

Check choke piston as follows.

- 1) Disconnect choke piston hose at throttle chamber.
- 2) With choke valve pushed down to its closing side lightly by finger, apply vacuum, to choke piston hose with vacuum pump gauge, and check to ensure that choke valve to carburetor bore clearance is within the specification.

Choke valve to carburetor bore clearance	1.1 – 1.3 mm (0.04 – 0.05 in.)
--	-----------------------------------

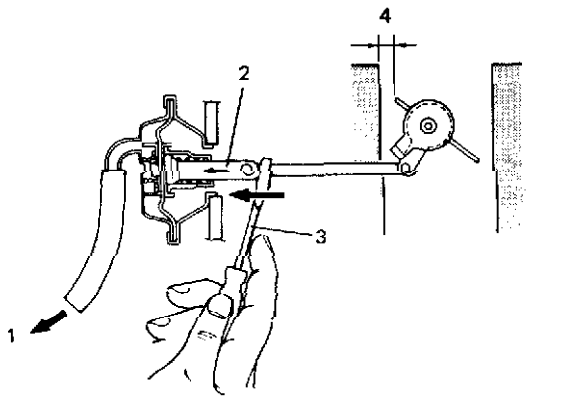


1. Choke piston hose  
2. Choke piston  
3. Vacuum (Apply -30 ~ -50 cm Hg vacuum)  
4. Choke valve  
5. Push here lightly  
6. Choke valve to carburetor bore clearance

**Fig. 4-1-53 Checking choke piston**

- 3) With vacuum applied as in step 2), move choke piston rod with small screw driver as shown and check to ensure that choke valve to carburetor bore clearance is within following specification.

Choke valve to carburetor bore clearance	3.2 – 3.7 mm (0.13 – 0.14 in.)
--	-----------------------------------



1. Vacuum (Apply -30 ~ -50 cm Hg vacuum)
2. Choke piston rod
3. Screw driver
4. Choke valve to carburetor bore clearance

Fig. 4- I-54 Moving choke piston rod

### Fast Idle Adjustment

#### NOTE:

Fast idle check and adjustment should be performed after making sure of the following.

- Ambient temperature is between 22°C and 28°C (71°F and 82°F).

\*Idle up system (idle up speed) is normal.

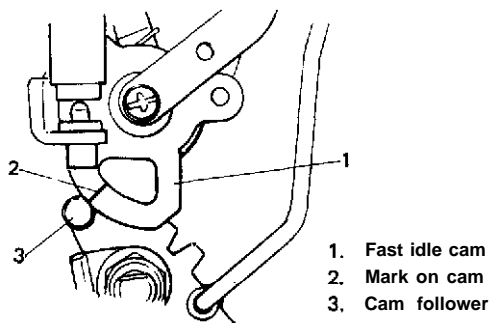
Check and adjustment procedure is as follows.

- 1) Leave car at a place where ambient temperature is between 22°C and 28°C (71°F and 82°F), for over 4 hours.

#### NOTE:

When carburetor is removed, leave carburetor at the place mentioned above for an hour and check as follows.

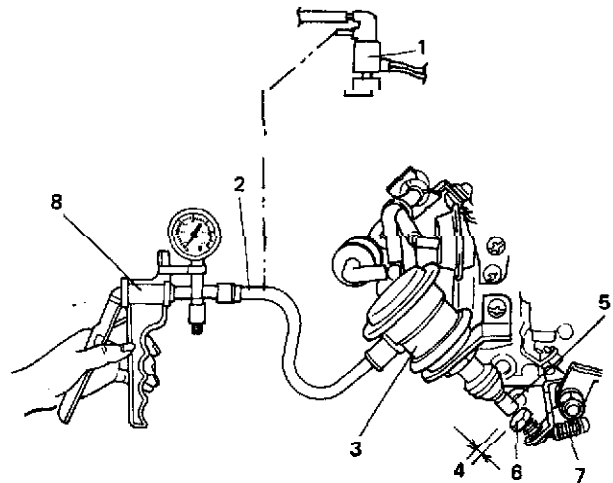
- 2) After leaving, make sure that the mark on cam and the center of cam follower are in alignment as shown in below figure.



1. Fast idle cam
2. Mark on cam
3. Cam follower

Fig. 4- I-55 Mark on cam and cam follower

- 3) Disconnect vacuum hose from TWSV and connect special tool (vacuum pump gauge) to its hose.



1. Twsv
2. Vacuum hose
3. Idle up actuator
4. Clearance
5. Actuator rod
6. Idle up adjusting screw
7. Fast idle adjusting screw
8. Special tool (Vacuum pump gauge)

With applying about 40 cmHg vacuum to actuator.

- 4) Check clearance between actuator rod and idle up adjusting screw.

Clearance "4" for fast idle	2.5 ~ 3.0 mm (0.10 ~ 0.12 in.)
--------------------------------	-----------------------------------

If clearance is out of specification, adjust it to specification with fast idle adjusting screw.

### Unloader Adjustment

Perform this check and adjustment when engine is cool.

- 1) Remove air intake case.
- 2) Make sure that choke valve is fully closed.
- 3) Fully open throttle valve and check choke valve to carburetor bore clearance to ensure it is within following specification.

- 4) If clearance is out of specification, adjust by bending the unloader arm indicated in below figure.

Choke valve to carburetor bore clearance	2.5 – 3.2 mm (0.10 – 0.12 in.)
--	-----------------------------------

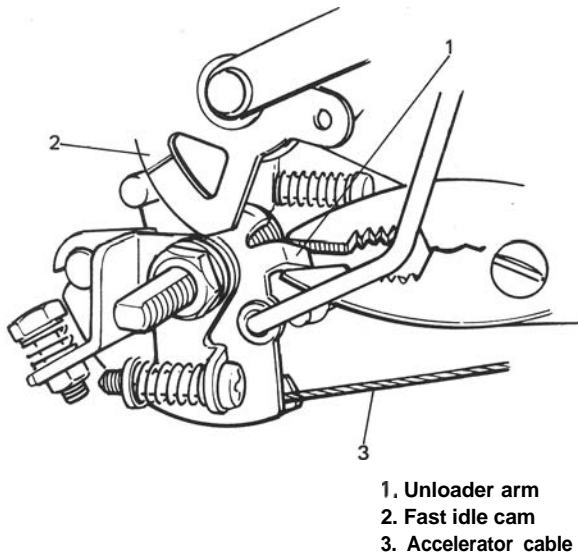


Fig. 4-1-57 Unloader lever arm

#### Checking Acceleration Pump

- 1) Remove air intake case.
- 2) Make sure that fuel comes out of pump discharge nozzle when accelerator pedal is depressed.

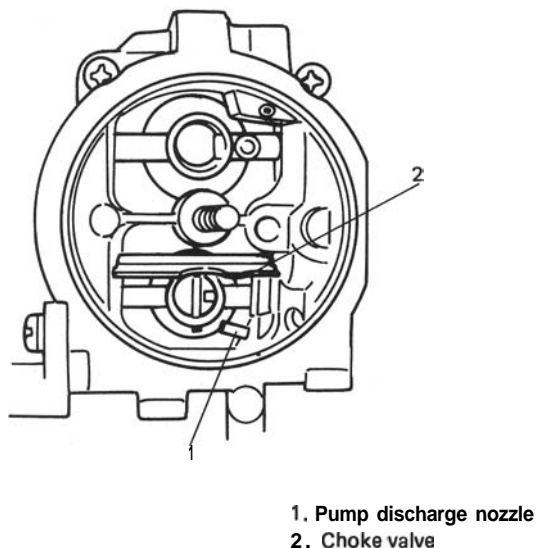


Fig. 4- 1-58 Pump discharge nozzle

#### Checking Secondary System

- 1) Remove air intake case.
- 2) Disconnect hose ① from 3 way joint, and connect vacuum pump gauge.
- 3) Open primary throttle valve fully.
- 4) Check if secondary throttle valve opens smoothly and is held there when vacuum (10 cmHg) is applied to actuator.
- 5) Disconnect hose ② from 3 way joint and connect vacuum pump gauge to its hose. Plug hose ① with finger.
- 6) Turn ignition switch to "ON" position and open primary throttle valve fully. 5 or 6 seconds later, make the same check as in above step 4).

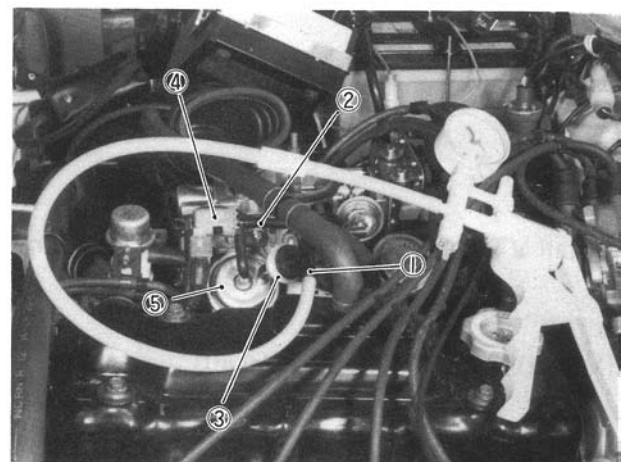


Fig. 4- 1-59  
1. Hose 2. Hose 3. VTV 4. vsv 5. Actuator

If check result in step 4) is not satisfactory, check VTV, and if that in step 6) is not satisfactory, check VSV.

If not satisfactory in either step 4) or 6) and both VTV and VSV are in good condition, replace actuator.

#### [VTV (Vacuum Transmitting Valve)]

Remove VTV. Use a vacuum pump gauge for VTV check. If pointer of vacuum pump gauge reacts as described below in each condition, VTV is in good condition.

With vacuum pump gauge set at Brown side of VTV, when pump is operated, pointer doesn't move (remains at zero position).

With vacuum pump gauge set at Black side of VTV, when pump is operated, pointer moves considerably but moves back to zero position as soon as pump operation is stopped.

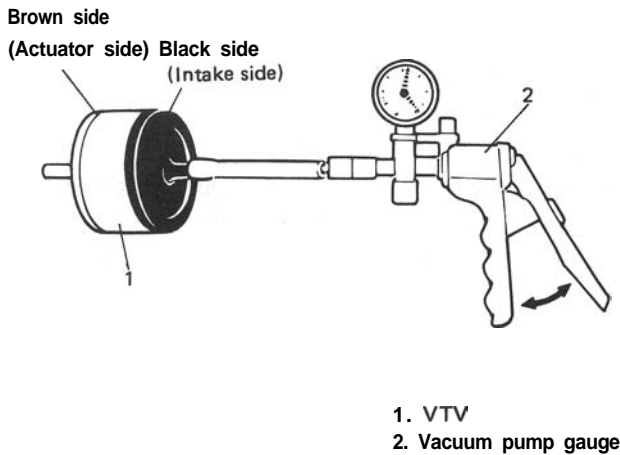


Fig. 4-1-60

install VTV. Refer to Fig. 4-1-2 for installation.

[ VSV (Vacuum Switching Valve)]

- 1) Disconnect VSV vacuum hoses from 3 way joint and secondary actuator and while blowing either hose, check that air doesn't come out of the other hose.
- 2) Turn on ignition switch and depress accelerator pedal fully. 5 or 6 seconds later, while blowing either vacuum hose, check that air comes out of the other hose.

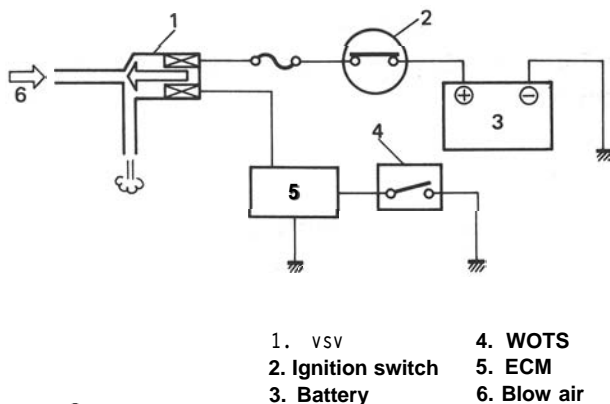


Fig. 4-1-61

If check results in steps 1) and 2) are not satisfactory, either replace VSV or check WOTS and its circuit referring to SECTION5 "EMISSION CONTROL SYSTEM".

Idle Speed Adjustment

NOTE:

Before starting engine, place transmission gear shift lever in "Neutral", and set parking brake and block drive wheels.

Before idle speed check and adjustment, make sure of the following.

- Lead wires and hoses of engine emission control systems are connected securely.
- Accelerator cable has some play, that is, it is not tight.
- All vacuum hoses are connected securely.
- Fuel level should be within round mark at the center of level gauge.
- Valve lash is checked and adjusted according to the maintenance schedule.
- Air cleaner has been properly installed and is in good condition.
- All accessories (wipers, heater, lights, etc) are out of service.
- Ignition timing is within specification.
- Idle up actuator is not operating when engine is running at idle speed.

NOTE:

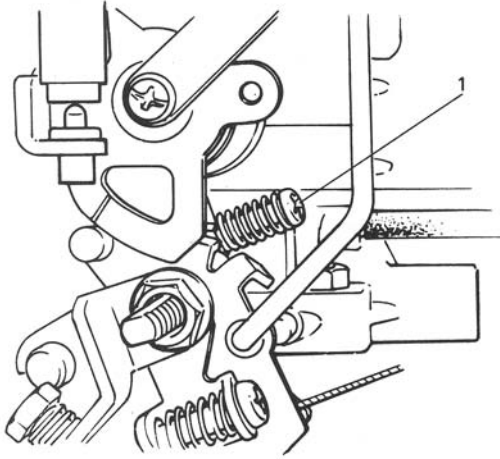
In areas above 4,000feet(1,220m) elevation (high altitude), idle up system will be normally in operation. Do not attempt to adjust the idle speed.

After above items are all confirmed, adjust idle speed as follows.

**WARNING:**

Keep hands, tools, and clothing away from engine cooling fan to help prevent personal injury.

- 1) Warm up engine to normal operating temperature.
- 2) Check to ensure that idle speed is within 750 – 850 r/min (rpm).
- 3) If idle speed is not within specified range, adjust by turning idle speed adjusting screw. If idle speed can not be adjusted to the specification by turning the adjusting screw, it can be due to faulty return of throttle valve or some other reason. Determine cause and repair, and then adjust idle speed to specification.



1. Idle speed adjusting screw

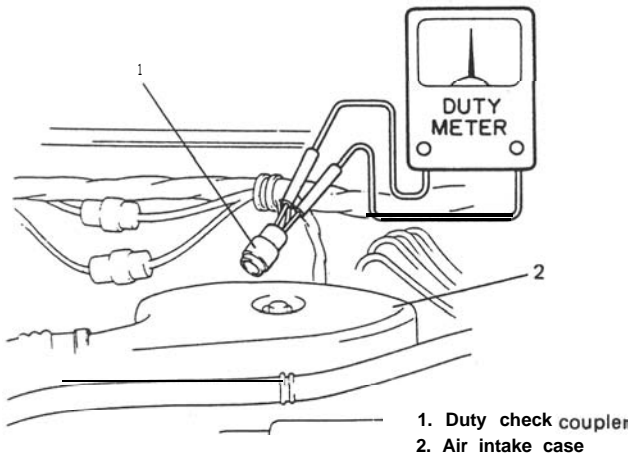
**Fig. 4- I-62 Idle speed adjusting screw**

- 4) After idle speed adjustment, check idle-up for operation with lights (small light, tail light, side marker light and license light), heater fan and rear defogger (if equipped) turned "ON", only one at a time. Refer to item "Idle Up Adjustment". (p. 4-20).
- 5) Stop engine and check to ensure that accelerator cable play is within the specification as previously outlined. If play is out of specification, adjust it.

#### Idle Mixture Inspection and Adjustment

##### [Inspection]

- 1) Warm up engine to normal operating temperature.
- 2) Remove seal rubber of duty check coupler and connect positive terminal of duty meter to "Blue/Red" wire and negative terminal to "Black/Green" wire.



1. Duty check coupler  
2. Air intake case

**Fig. 4- I-63**

- 3) Set tachometer.
- 4) Run engine at 1,500 – 2,000 r/min for 30 seconds and bring it to idle speed.
- 5) Check duty at specified idle speed. If it is out of specification, adjust it to specification according to following adjustment procedure.

Specified Duty	10 - 5 Ø at 750 – 850 r/min.
----------------	---------------------------------

After inspection, install seal rubber to duty check coupler.

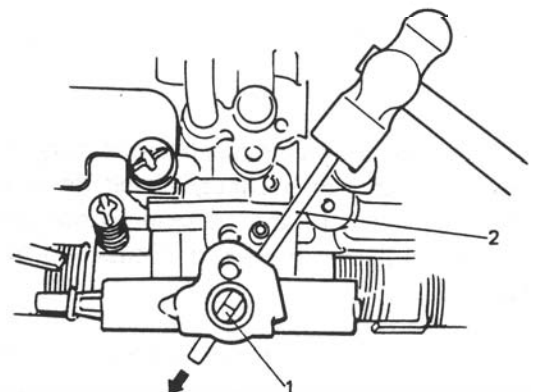
##### [Idle Mixture Adjustment]

The carburetor has been calibrated at the factory and should not normally need adjustment in the field. For this reason, the mixture adjustment should never be changed from the original factory setting. However, if during diagnosis, the check indicates the carburetor to be the cause of a driver performance complaint or emission failure, or the carburetor is overhauled or replaced, the idle mixture can be adjusted using the following procedure.

After adjustment, mixture adjusting screw pin must be installed.

Idle mixture adjustment procedure is as follows:

- 1) Remove carburetor from intake manifold following normal service procedure to gain access to mixture adjusting screw pin covering mixture adjusting screw.
- 2) Drive out mixture adjusting screw pin using about 4.5 mm (0.18 in) thick iron rod as shown below.



1. Mixture adjusting screw pin  
2. Rod

**Fig. 4- I-64 Mixture adjusting screw pin**

3) Reinstall carburetor following normal service procedures.

Connect emission control system hoses and lead wires. Make specified play on accelerator cable and refill cooling system.

4) Place transaxle gear shift lever in "Neutral", set parking brake and block drive wheels.

5) Start engine, and warm it up to normal operating temperature, stop engine.

6) Be sure to check the following before idle mixture adjustment.

- Fuel level is within round mark at the center of level gauge.
- Valve lash is checked and adjusted according to the maintenance schedule.
- Air cleaner has been properly installed and is in good condition.
- All accessories (wipers, heater, lights etc) are out of service.
- Ignition timing is within specification.
- Choke valve opens fully.
- Idle-up actuator does not operate.

7) Check and adjust idle speed to specification if necessary.

8) Remove seal rubber of duty check coupler and connect positive terminal of duty meter to "Blue/Red" wire and negative terminal to "Black/Green" wire.

9) Run engine at 1,500 – 2,000 r/min for 30 seconds and bring it to idle speed.

10) With engine running at idle speed, adjust idle mixture adjusting screw slowly in small increment allowing time for duty to stabilize after turning screw to obtain duty of 10 – 50. If duty is too low, back screw out; if too high, screw it in. After obtaining duty of 10 – 50, recheck idle speed, and adjust if necessary.

**NOTE:**

**If adjustment can't be made because duty meter indicator does not deflect, check feed back system according to the checking procedure of system described in section of Emission Control System.**

11) After adjustment, install seal rubber to duty check coupler and drive in idle mixture adjusting screw pin.

## 4-2. AIR CLEANER

### GENERAL DESCRIPTION

In the air cleaner case, a dry-type air cleaner element is provided for filtering out dirt and dust from air being drawn into the engine for combustion.

A damaged element must be replaced with a new one, since it allows dust particles to enter the engine if used as it is. Such dust particles could cause wear to the engine inner parts and this further results in decreased output.

Also, the element must be cleaned periodically. Dusty and dirty element causes decrease in output and increase in fuel consumption. The dusty element even after cleaning should be replaced with a new one.

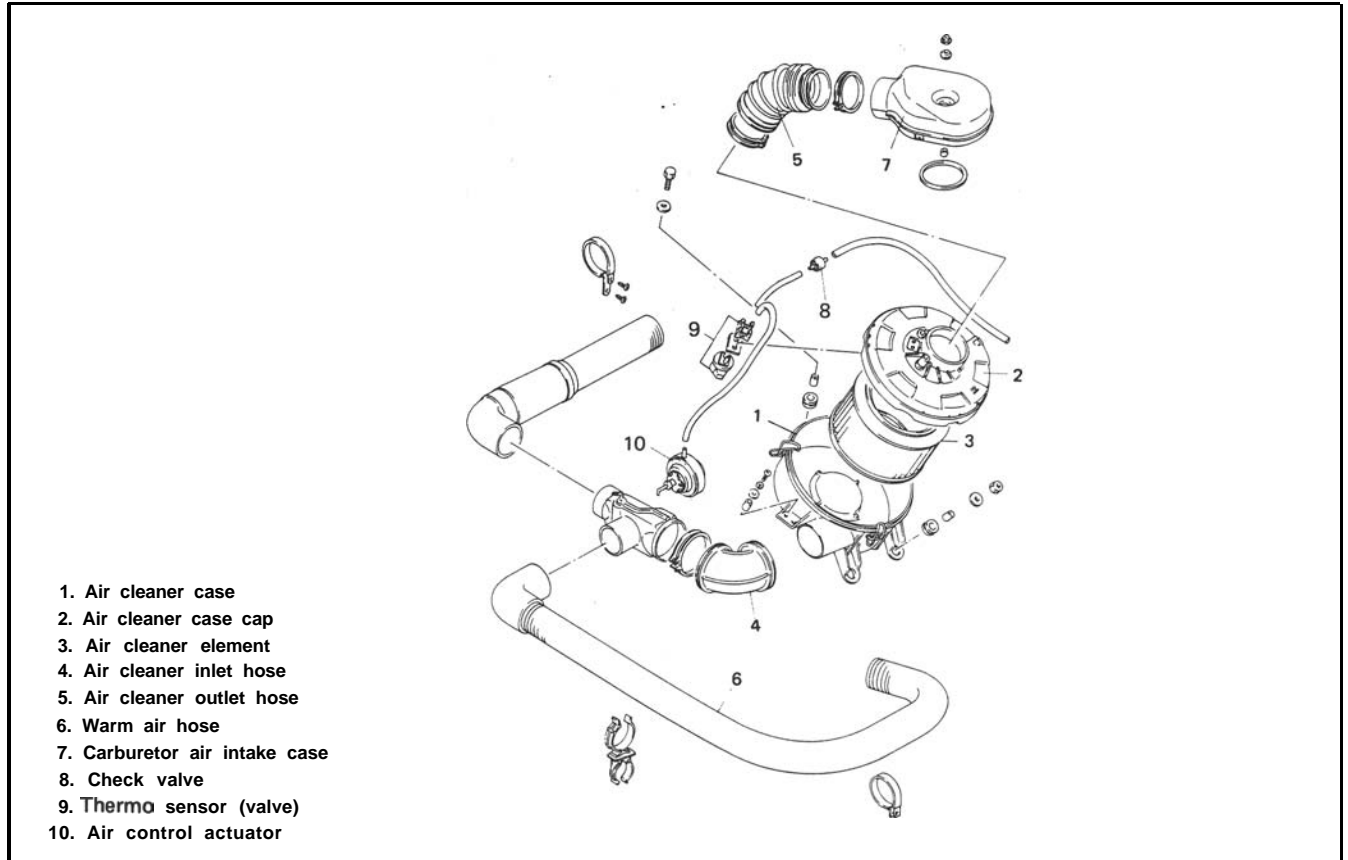


Fig. 4-2-1

### MAINTENANCE SERVICES

#### Air Cleaner Element

##### [Cleaning]

- 1) Remove air cleaner outlet hose and case cap.

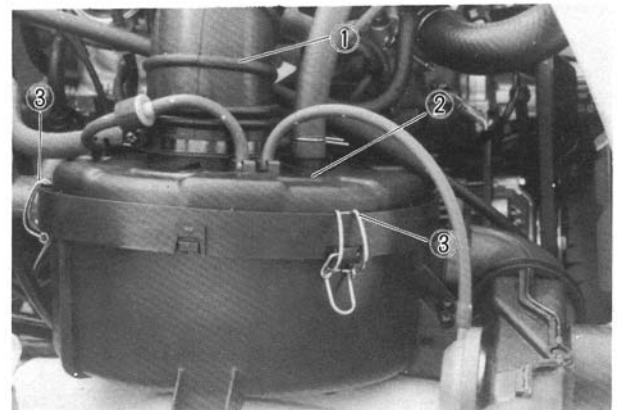


Fig. 4-2-2

1. Air cleaner outlet hose
2. Air cleaner case cap
3. Clamp

- 2) Take out air cleaner element from air cleaner case and blow off dust with compressed air from inside of element.

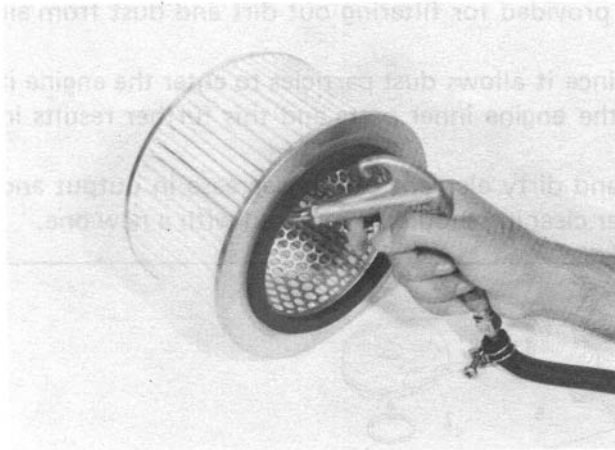


Fig. 4-2-3

- 3) Install element and cap by fitting cap groove to case securely, and be sure to clamp cap.
- 4) Install air cleaner outlet hose.

[Replacement]

- 1) Remove air cleaner outlet hose and case cap.
- 2) Remove air cleaner element.

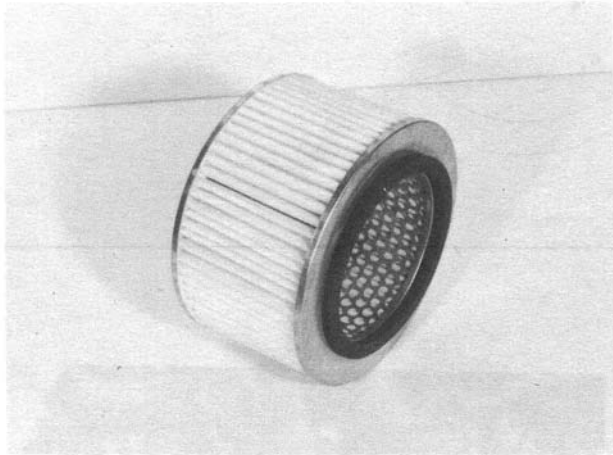


Fig. 4-2-4

- 3) Install new element and cap by fitting cap groove to case securely, and be sure to clamp cap.
- 4) Install air cleaner outlet hose.

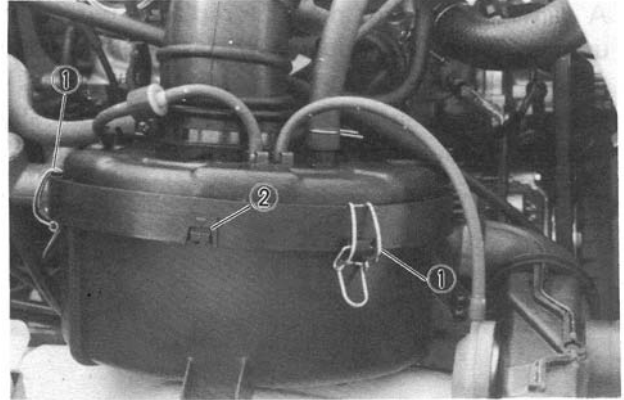


Fig. 4-2-4- 1

1. Clamp
2. Groove



### 4-3. FUEL PUMP, FILTER AND LINES

#### GENERAL DESCRIPTION

The main components of the fuel system are fuel tank, fuel pump and fuel filter and it includes three lines; fuel feed line, fuel return line and fuel vapor line.

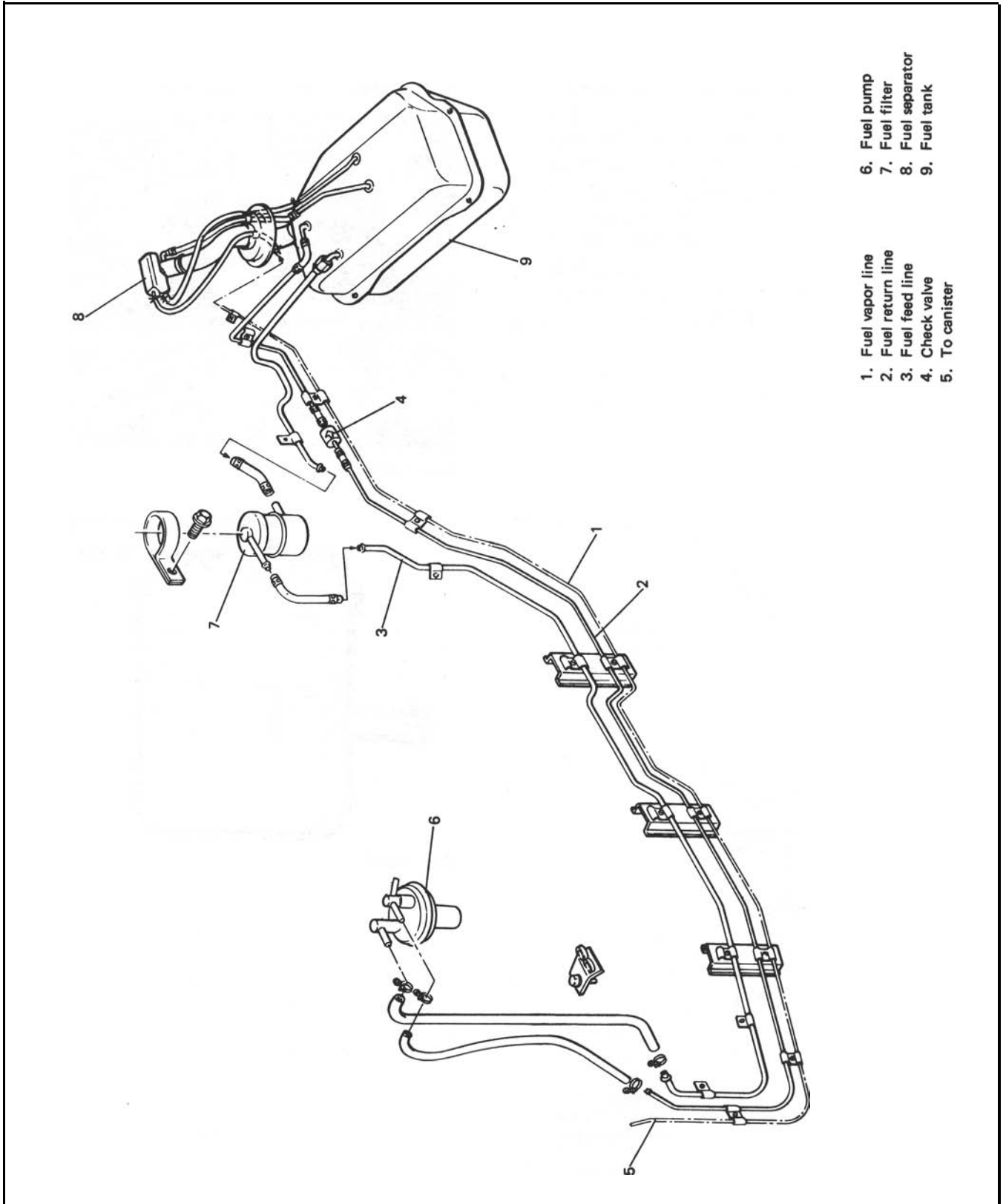


Fig. 4-2-5

## Fuel Pump

A mechanical fuel pump is mounted on the cylinder head.

The diaphragm in fuel pump is actuated from the cam on the engine camshaft, through a fuel pump rod and a rocker arm of fuel pump. A rocker arm rides on the cam through the fuel pump rod and moves the pump diaphragm up and the fuel pump feeds the fuel into carburetor. A fuel return circuit is provided in this pump in order to avoid "vapor lock". When the float chamber refuses to admit fuel, a slight pressure buildup occurs on the discharge side of the pump and this buildup causes the fuel to flow through the return circuit to the fuel tank. In other words, the fuel pump is kept in action as long as the engine is running, so that the constant flow of fuel through the pump keeps it cool.

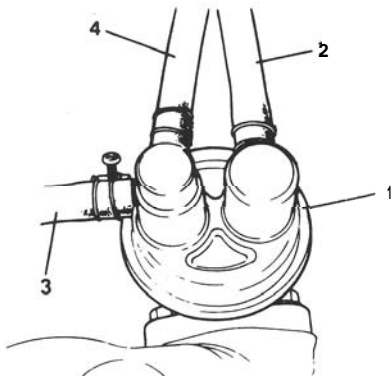


Fig. 4-2-6

1. Fuel pump
2. inlet hose
3. Outlet hose
4. Return hose

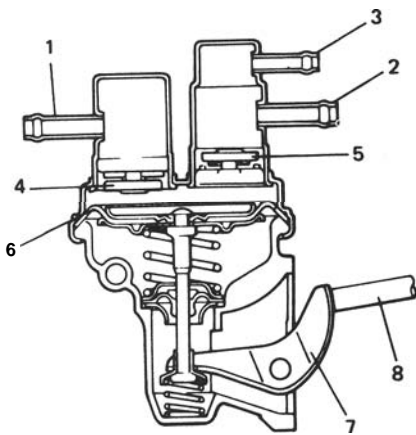


Fig. 4-2-7

1. Inlet
2. Outlet
3. Return tube
4. inlet valve
5. Outlet valve
6. Diaphragm
7. Rocker arm
8. Fuel pump rod

## Fuel Filter

Fuel filter is located at the front part of fuel tank, inside the right-hand side of chassis.

Fuel enters the filter through its inlet hose and, after passing through filtering element, comes out of its outlet hose communicated to the fuel pump. This filter is not meant to be disassembled. It is of cartridge type, consisting of a filtering element in a plastic case.

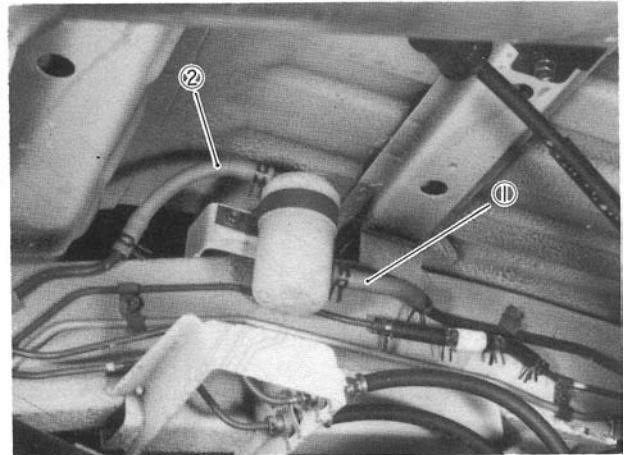


Fig. 4-2-8

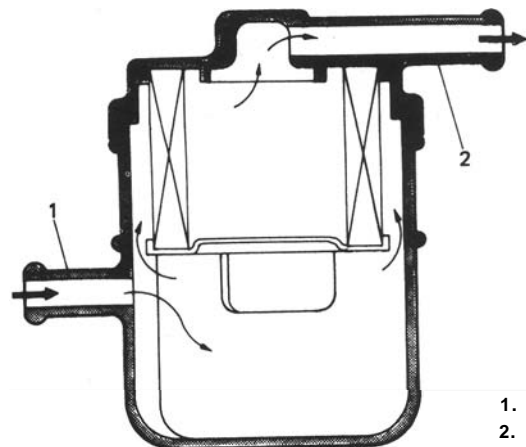


Fig. 4-2-9

1. Inlet
2. Outlet

## Fuel Filler Cap

The fuel tank filler neck has a pressure-vacuum cap.

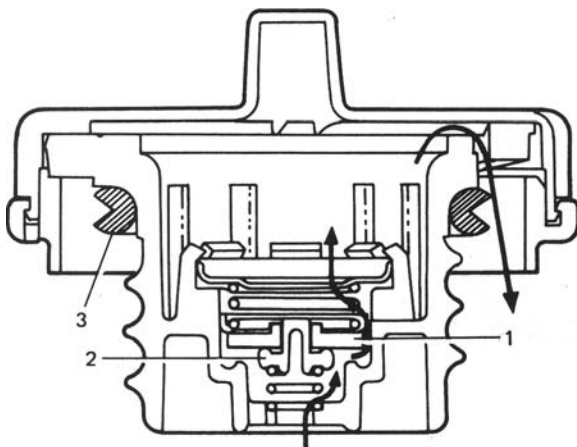
A ratchet tightening device on the threaded fuel filler cap reduces the chances of incorrect installation, which would prevent sealing fuel vapors.

After the gasket on fuel filler cap and the filler neck flange contact, the ratchet produces a loud clicking noise, indicating the seal has been set.

This cap has pressure relief valve and vacuum relief valve inside.

If the pressure of fuel vapor in fuel tank should exceed that for which fuel system is designed, the pressure relief valve opens to relieve the pressure.

The vacuum relief valve opens to relieve the vacuum created in fuel tank.



1. Pressure relief valve
2. Vacuum relief valve
3. Gasket

Fig. 4-2-10 Fuel filler cap cross-section

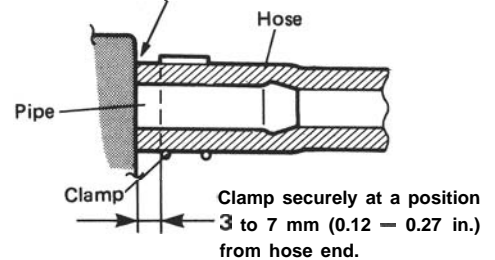
## REMOVAL AND INSTALLATION

### CAUTION:

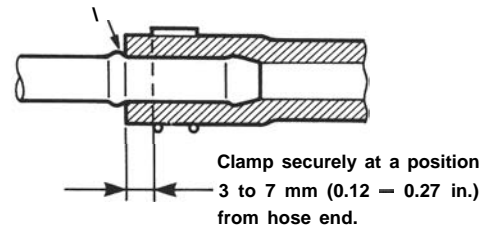
Before attempting service of any type on fuel system, the following cautions should be always observed.

- Disconnect negative cable at battery.
- DO NOT smoke, and place "NO SMOKING" signs near work area.
- Be sure to have CO<sub>2</sub> fire extinguisher handy.
- Wear safety glasses.
- To release fuel vapor pressure in fuel tank, remove fuel filler cap from fuel filler neck and then reinstall it. If pressure in fuel tank is not released beforehand, fuel in fuel tank may come out of fuel hoses due to the pressure when they are disconnected.
- Note that fuel hose connection varies with each type of pipe. Be sure to connect and clamp each hose correctly referring to the following.

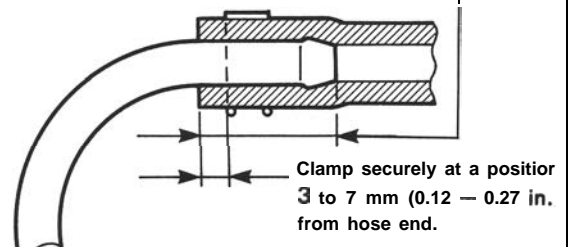
With following type pipe, fit hose as far as it reaches pipe joint as shown.



With following type pipe, fit hose as far as its peripheral projection as shown.



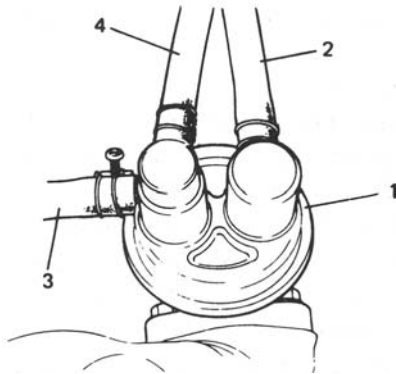
With following type pipe, fit hoses as far as its bent part as shown or till pipe is about 20 to 30 mm (0.79 – 1.18 in.) into the hose.



## Fuel Pump

### [Removal]

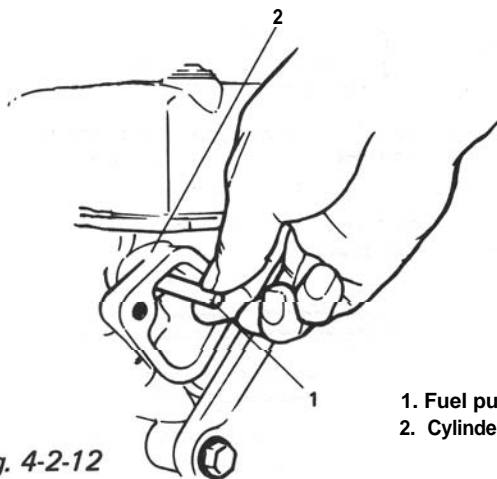
- 1) Disconnect negative cable from battery.
- 2) Remove fuel filler cap from fuel filler neck to release fuel vapor pressure in fuel tank. After releasing, reinstall the cap.
- 3) Disconnect fuel inlet, outlet and return hoses from fuel pump.



1. Fuel pump
2. Inlet hose
3. Outlet hose
4. Return hose

Fig. 4-2-11

- 4) Remove fuel pump from cylinder head.
- 5) Remove fuel pump rod from cylinder head.



1. Fuel pump rod
2. Cylinder head

Fig. 4-2-12

### [Installation]

Reverse removal procedure for installation using care for the following.

- After oiling it, install fuel pump rod to cylinder head.
- Use new fuel pump gasket.
- Make sure for proper hose connection.
- Upon completion of installation, start engine and check fuel hose or its joints for leaks.

## Fuel Filter

### [Removal]

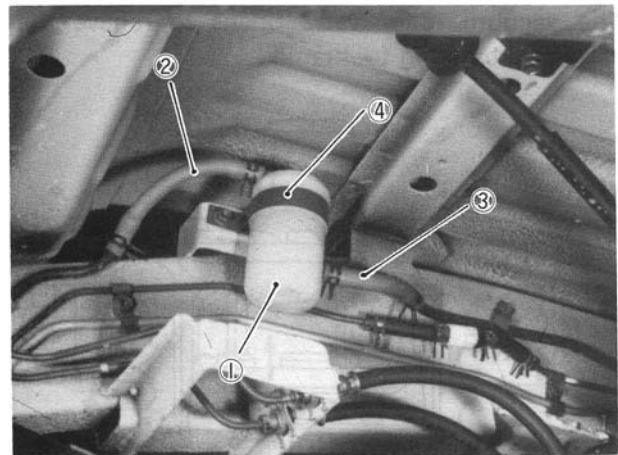
- 1) Disconnect negative cable from battery.
- 2) Remove fuel filler cap to release fuel vapor pressure in fuel tank. After releasing, reinstall the cap.
- 3) Disconnect inlet and outlet hoses from fuel filter.
- 4) Remove fuel filter with clamp.

### [Installation]

- 1) Install filter and clamp, and connect inlet and outlet hoses to fuel filter.

### NOTE:.

The top connection is for outlet hose, the lower one for inlet hose.



1. Fuel filter
2. To fuel pump
3. From fuel tank
4. Clamp

Fig. 4-2-13

- 2) Connect negative cable to battery.
- 3) After installation, start engine and check it for leaks.

## Fuel Tank

### [Removal]

- 1) Disconnect negative cable from battery.
- 2) Disconnect fuel level gauge lead wire.
- 3) To release the pressure in fuel tank, remove fuel filler cap and then, reinstall it.
- 4) Raise car on hoist.
- 5) Drain fuel by removing drain plug.
- 6) Remove filler hose protector.
- 7) Disconnect filler hose from fuel tank.
- 8) Disconnect fuel hoses and pipe from fuel tank.
- 9) Remove fuel tank.

[Fuel tank purging procedure]

**WARNING:**

This purging procedure will NOT remove all fuel vapor. Do not attempt any repair on tank where heat or flame is required, as an explosion resulting in personal injury could occur.

The following procedure is used for purging the fuel tank.

- 1) After removing fuel tank, remove all hoses, fuel level gauge from fuel tank.
- 2) Drain all remaining fuel from tank.
- 3) Move tank to flushing area.
- 4) Fill tank with warm water or tap water, and agitate vigorously and drain. Repeat this washing until inside of tank is clean. Replace tank if inside is rusty.
- 5) Completely flush out remaining water after washing.

[ Installation]

Reverse removal procedure for installation using care for the following.

Tightening torque for fuel tank drain plug	30-45 Nm (3.0 – 4.5 kg-m) (22.0 – 32.5 lb-ft)
--	---

Refer to Fig. 4-2-5 for piping and clamp positions.

- Make sure for correct hose-to-pipe connection.
- Clamp hoses securely.
- Upon completion of installation, start engine and check hose joints for leaks.

**MAINTENANCE SERVICES**

**Fuel Lines**

Visually inspect fuel lines and connections for evidence of fuel leakage, hose cracking, and damage. Make sure all clamps are secure.

Repair leaky joints, if any.

Replace hoses that are suspected of being cracked.

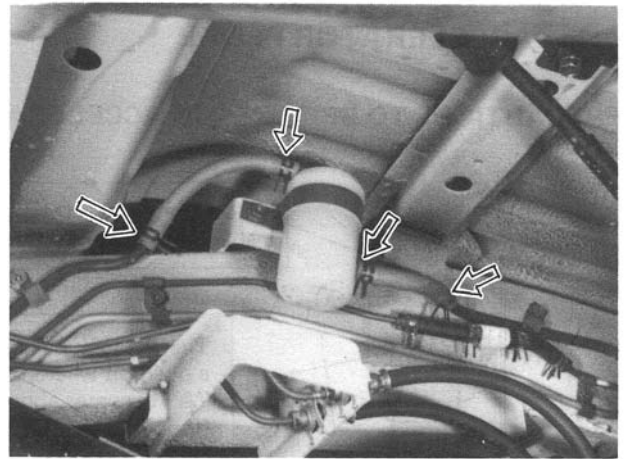


Fig. 4-2-14

**Fuel Filler (tank) Cap**

Visually inspect gasket of fuel filler cap.

If it is damaged or deteriorated, replace filler cap with new one.

**NOTE:**

If cap requires replacement, only a cap with the same features should be used. Failure to use correct cap can result in a serious malfunction of the system.

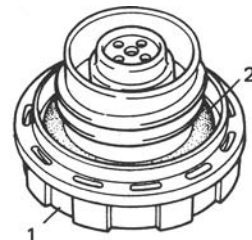


Fig. 4-2-15

1. Fuel filler cap
2. Fuel filler capgasket

**Fuel Filter**

As said before, this filter does not permit disassembly: it is to be replaced with a new one periodically.

Replace fuel filter referring to previous item of “Fuel Filter Removal and Installation”.

**WARNING:**

This servicing must be performed in a well ventilated area and away from any open flames (such as gas hot water heaters).

## 4-4. ACCELERATOR PEDAL

### PRECAUTIONS TO BE TAKEN IN ACCELERATOR PEDAL INSTALLATION

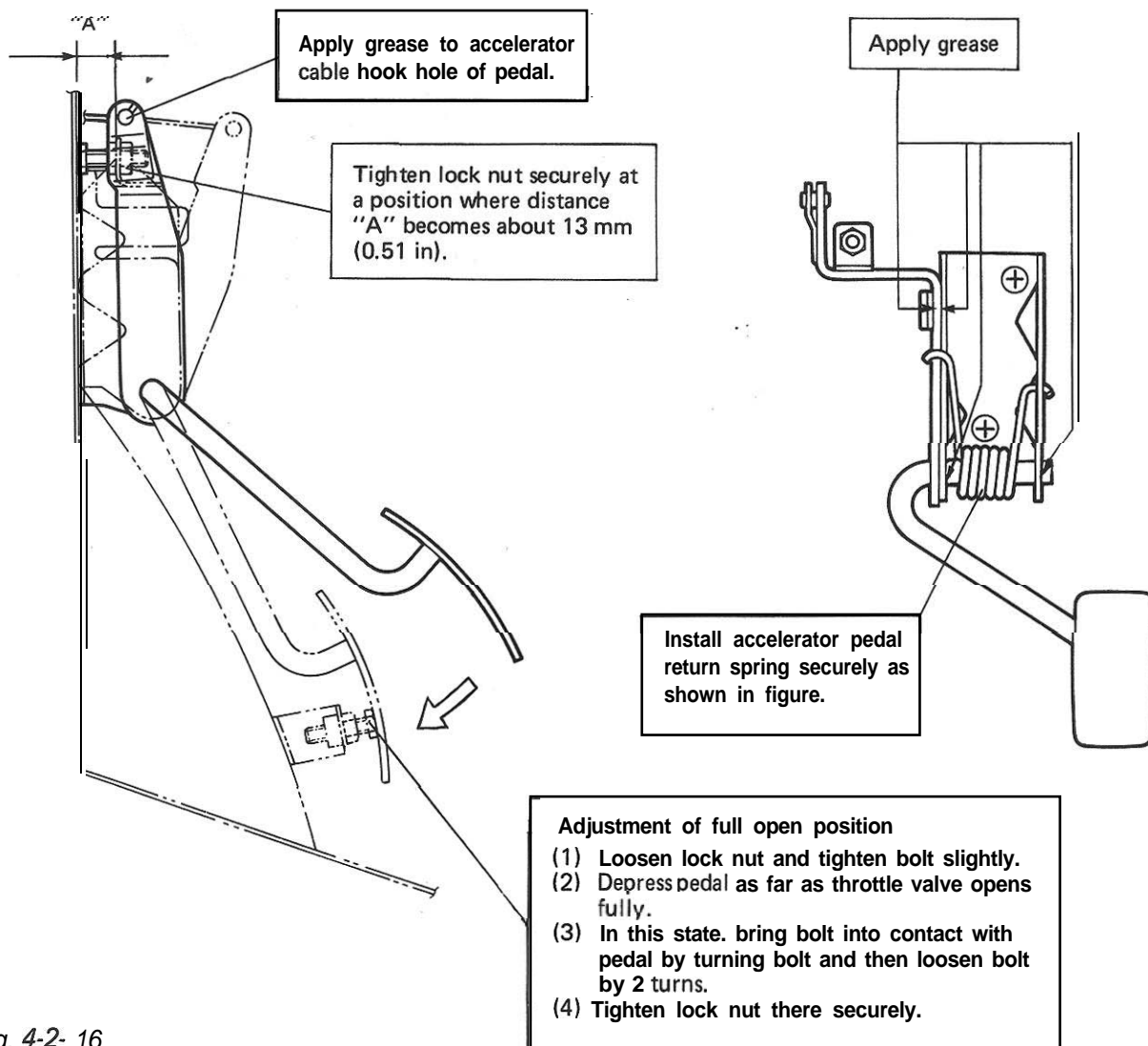


Fig. 4-2- 16

## SECTION 5

# EMISSION CONTROL SYSTEM

## CONTENTS

5-1.	GENERAL DESCRIPTION .....	5-4
	POSITIVE CRANKCASE VENTILATION (PCV) SYSTEM .....	5-5
	THERMOSTATICALLY CONTROLLED AIR CLEANER (TCAC) SYSTEM .....	5-6
	EVAPORATIVE EMISSION CONTROL SYSTEM .....	5-7
	HOT IDLE COMPENSATOR (HIC) .....	5-8
	DECELERATION MIXTURE CONTROL SYSTEM .....	5-9
	COMPUTER CONTROLLED EMISSION CONTROL SYSTEM .....	5-10
	BOWL VENTILATION SYSTEM .....	5-12
	FUEL CUT SYSTEM .....	5-13
	EXHAUST GAS RECIRCULATION (EGR) SYSTEM .....	5-14
5-2.	DIAGNOSIS .....	5-15
5-3.	MAINTENANCE SERVICE .....	5-18
	GENERAL .....	5-18
	PCV SYSTEM .....	5-18
	TCAC SYSTEM .....	5-19
	EVAPORATIVE EMISSION CONTROL SYSTEM .....	5-20
	HOT IDLE COMPENSATOR (HIC) .....	5-21
	DECELERATION MIXTURE CONTROL SYSTEM .....	5-21
	FEED BACK SYSTEM .....	5-22
	SWITCH VENT SOLENOID .....	5-36
	FUEL CUT SYSTEM .....	5-36
	EGR SYSTEM .....	5-37

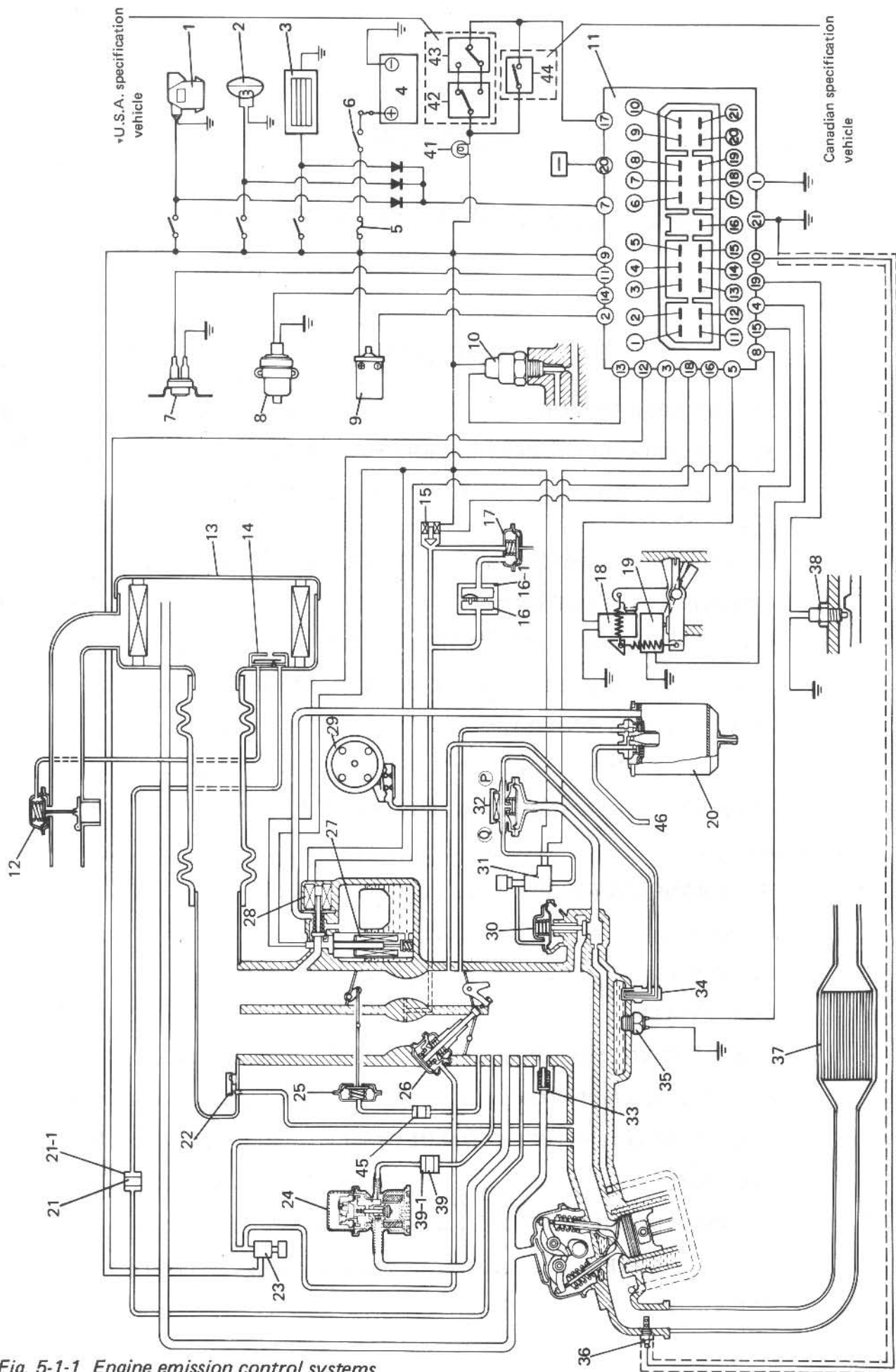


Fig. 5-1-1 Engine emission control systems



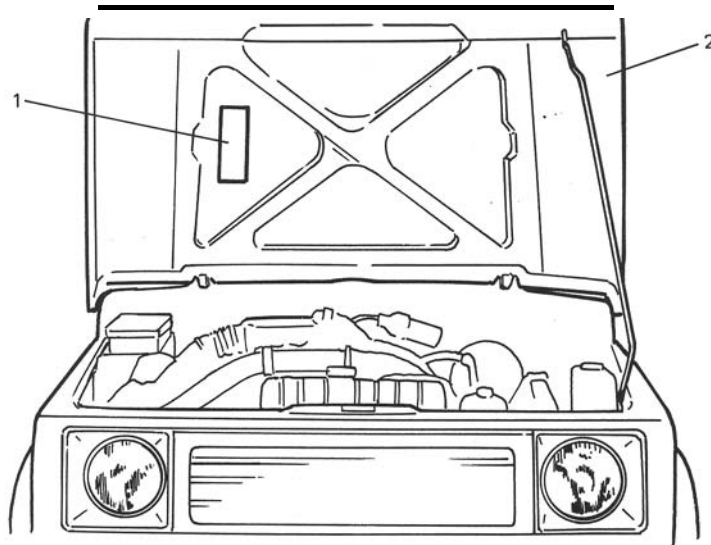
- |   |  |   |
|---|--|---|
| 1. Heater fan                               | 21. Check valve (black)                        | 39-1. Gray side                                   |
| 2. Small, Tail, Side marker & license light | 21-1. Orange side                              | 40. Check connector                               |
| 3. Rear defogger                            | 22. Hot idle compensator (HIC)                 | 41. "CHECK ENGINE" light                          |
| 4. Battery                                  | 23. Three way solenoid valve (TWSV)            | 42. Mileage sensor (U.S.A. specification vehicle) |
| 5. Fuse (circuit fuse)                      | 24. Mixture control valve (MCV)                | 43. Cancel switch (U.S.A. specification vehicle)  |
| 6. Ignition switch                          | 25. Choke piston                               | 44. Check switch (Canadian specification vehicle) |
| 7. Thermal engine room switch               | 26. Idle up actuator                           | 45. Delay valve (orifice)                         |
| 8. High altitude compensator (HAC)          | 27. Mixture control solenoid valve (MCSV)      | 46. To fuel tank                                  |
| 9. Ignition coil                            | 28. Vent solenoid valve                        |   |
| 10. Fuel cut solenoid                       | 29. Distributor                                |   |
| 11. Electronic control module (ECM)         | 30. Exhaust gas recirculation (EGR) valve      |   |
| 12. Air control actuator                    | 31. Three way solenoid valve (TWSV)            |   |
| 13. Air cleaner                             | 32. EGR modulator                              |   |
| 14. Thermo sensor                           | 33. Positive crankcase ventilation (PCV) valve |   |
| 15. Vacuum switching valve (VSV)            | 34. Bi-metal vacuum switching valve (BVSV)     |   |
| 16. Vacuum transmitting valve (VTV)         | 35. Thermal switch                             |   |
| 16-1. Brown side                            | 36. Oxygen sensor                              |   |
| 17. Secondary throttle valve actuator       | 37. Three way catalyst                         |   |
| 18. Wide open micro switch                  | 38. Fifth switch                               |   |
| 19. Idle micro switch                       | 39. Jet (colorless)                            |   |
| 20. Vapor storage canister                  |  |   |

## 5-1. GENERAL DESCRIPTION

### VEHICLE EMISSION CONTROL INFORMATION LABEL

The Vehicle Emission Control Information Label is located under hood. The label contains important emission specifications and setting procedures, as well as a vacuum hose schematic with emission components identified.

When servicing the engine or emission systems, the Vehicle Emission Control Information Label should be checked for up-to-date information.



- 1. Emission control label
- 2. Hood

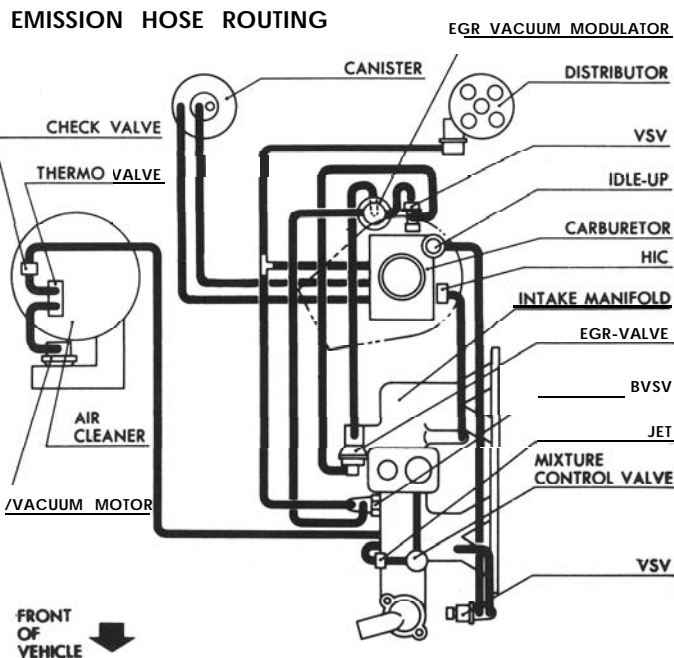


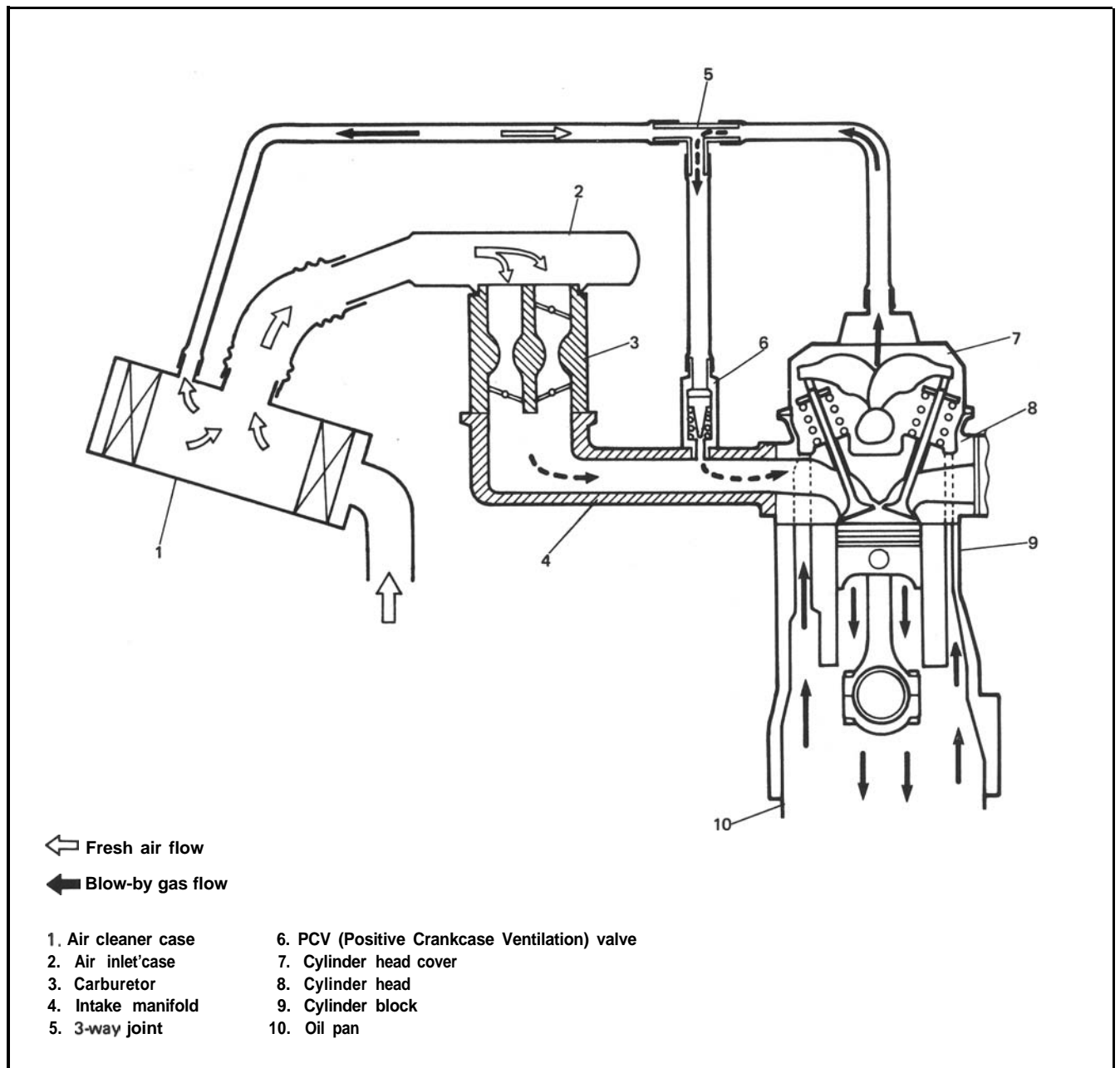
Fig. 5- 1-2 Vehicle emission control information label

**POSITIVE CRANKCASE VENTILATION (PCV) SYSTEM**  
**(Blow-by gas recycling system)**

The blow-by gas in the crankcase flows through the passage in the cylinder block into the cylinder head. The oil particles are separated from the blow-by gas by the oil separating unit in the cylinder head cover. The gas is then returned together with the fresh air coming from the air cleaner through the PCV valve into the intake manifold for recombustion.

When the vacuum in the intake manifold is low (when the opening of the throttle valve is large), the PCV valve is wide open due to its spring force. Thus a large amount of the blow-by gas is drawn into the intake manifold.

On the other hand, when the vacuum in the manifold is high, the PCV valve opening is limited due to the high vacuum. Thus the amount of the blow-by gas drawn into the intake manifold is small.



**Fig. 5-I-3 PCV system operation**



## EVAPORATIVE EMISSION CONTROL SYSTEM

An evaporative emission control system is used to prevent emission of fuel vapors from the vehicle fuel system.

The system allows evaporating fuel vapors to be stored, when the engine is not running.

This is accomplished by venting the fuel tank and carburetor float chamber through a vapor storage canister containing activated charcoal.

The major system components are vapor storage canister, vent solenoid, and liquid vapor separator.

The fuel vapor from the fuel tank is led into the canister and stored there when the engine is not running. The fuel vapor from the carburetor float chamber is also stored in the canister when the ignition switch is "OFF".

When engine runs, the fuel vapor stored in the canister is drawn into the carburetor together with fresh air.

For vent solenoid valve operation, refer to item of "BOWL VENTILATION SYSTEM."

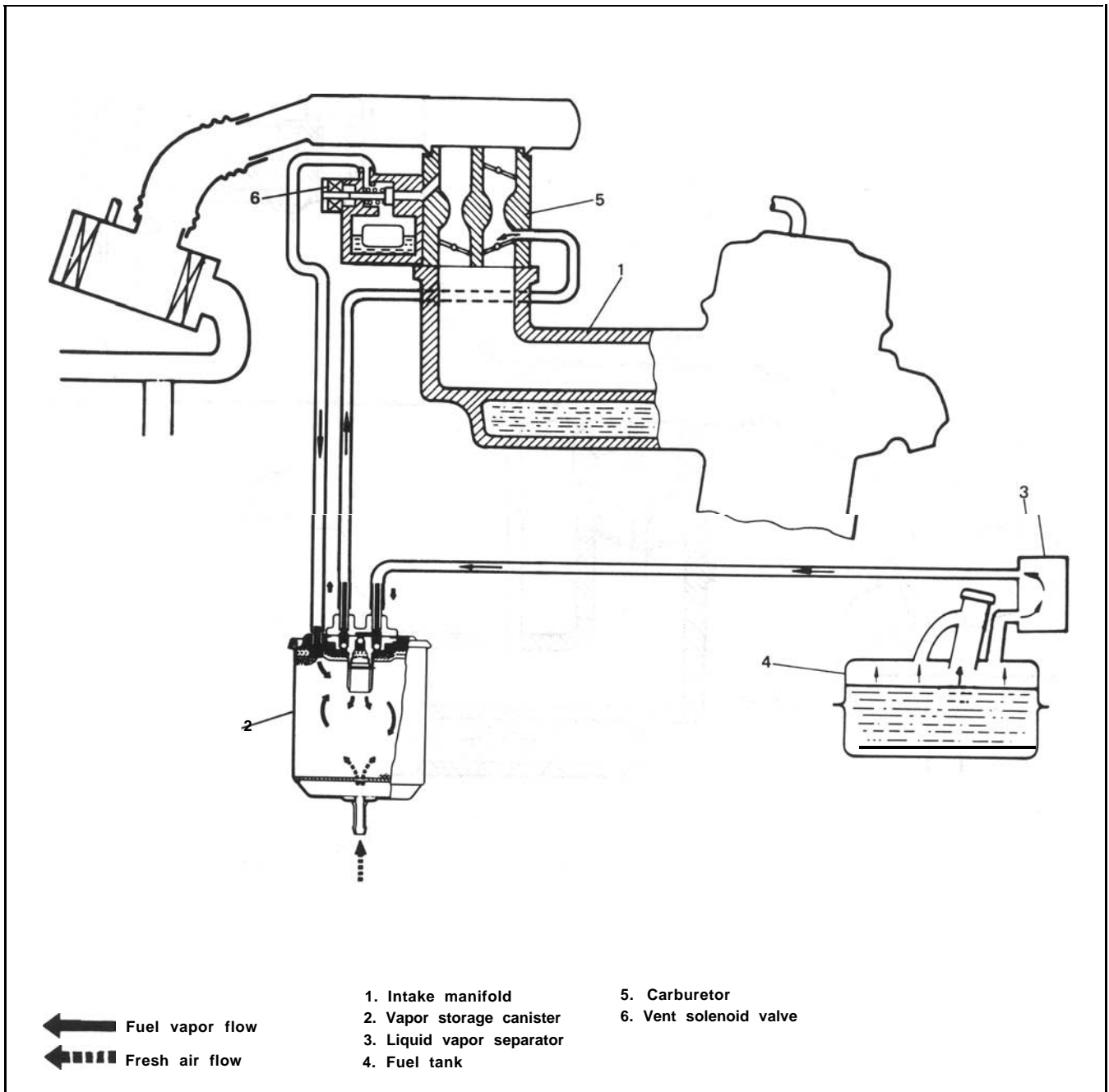


Fig. 5- I-5 Evaporative emission con trol sys tern

## HOT IDLE COMPENSATOR (HIC)

HIC attached to the air intake case serves to provide the optimum air/fuel mixture during hot idle so as to ensure stable idle speed.

HIC has a bimetal which warps as the heat transferred to it rises higher than about 55°C (131° F). Caused by this, the valve in HIC starts to open and it reaches to the full open state at about 70°C (158° F).

While the engine at idle, the throttle valve is closed and the vacuum in the intake manifold stays high. As the HIC valve opens in this state, the air from the air cleaner is drawn through the HIC valve into the intake manifold to prevent the air/fuel mixture getting richer during hot idle, thus maintaining a stable idle speed.

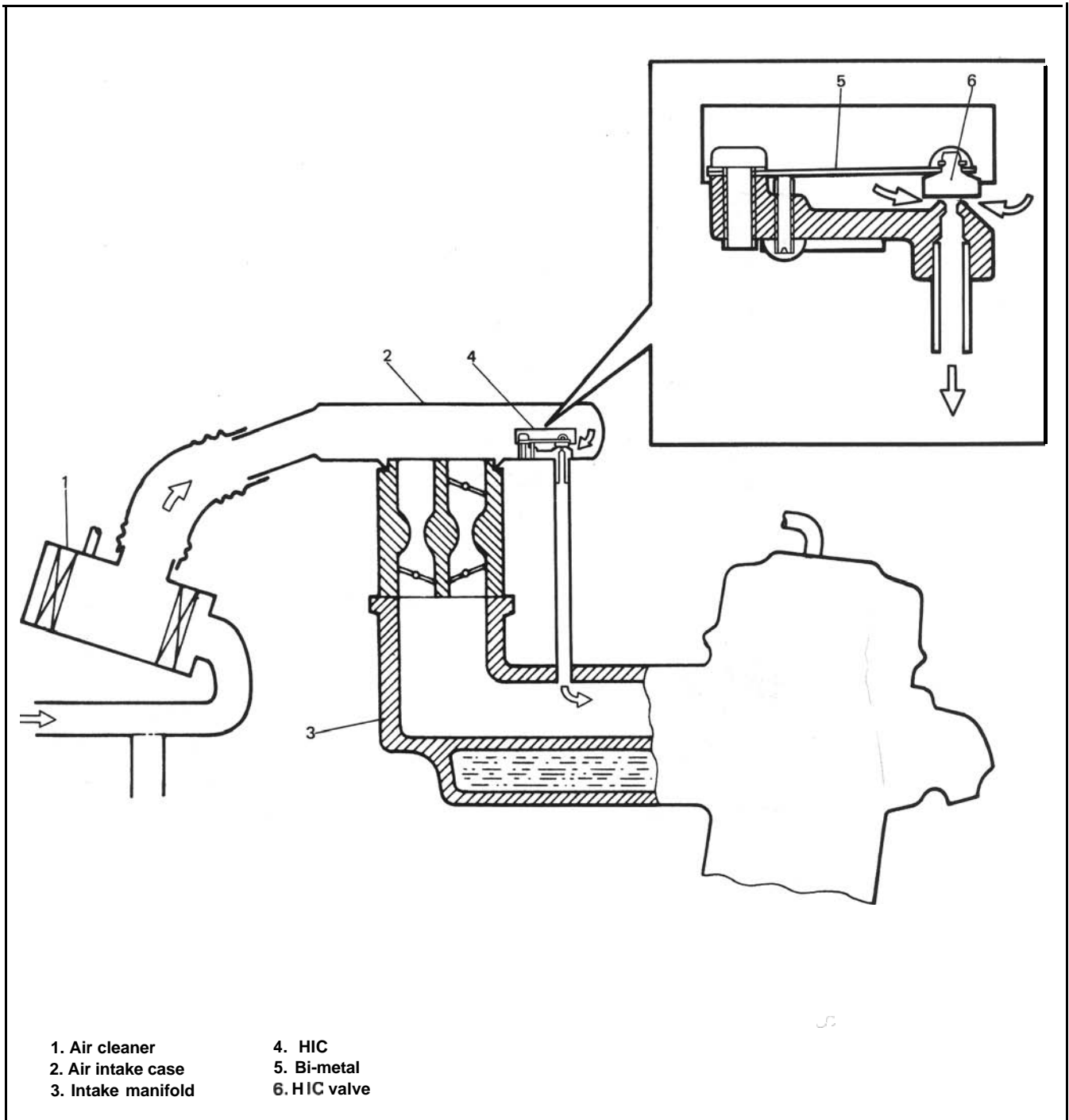


Fig. 5-1-6 Hot idle; compensator

## DECELERATION MIXTURE CONTROL SYSTEM

This system consists of a MCV (Mixture Control Valve), jet and vacuum hoses.

This system is designed to introduce fresh air into the intake manifold to reduce generation of excessive HC and CO emission caused by temporary rich air-fuel ratio while rapid deceleration.

The MCV has a pressure balancing orifice and check valve on its diaphragm, and closes when manifold vacuum is constant. As manifold vacuum increases according to rapid deceleration, manifold vacuum applies to MCV chamber "B" through jet, the MCV opens and introduces fresh air into the intake manifold. When manifold vacuum becomes constant, pressure difference between two sectioned chambers "A" and "B" gradually diminishes through pressure balancing orifice, then the MCV closes.

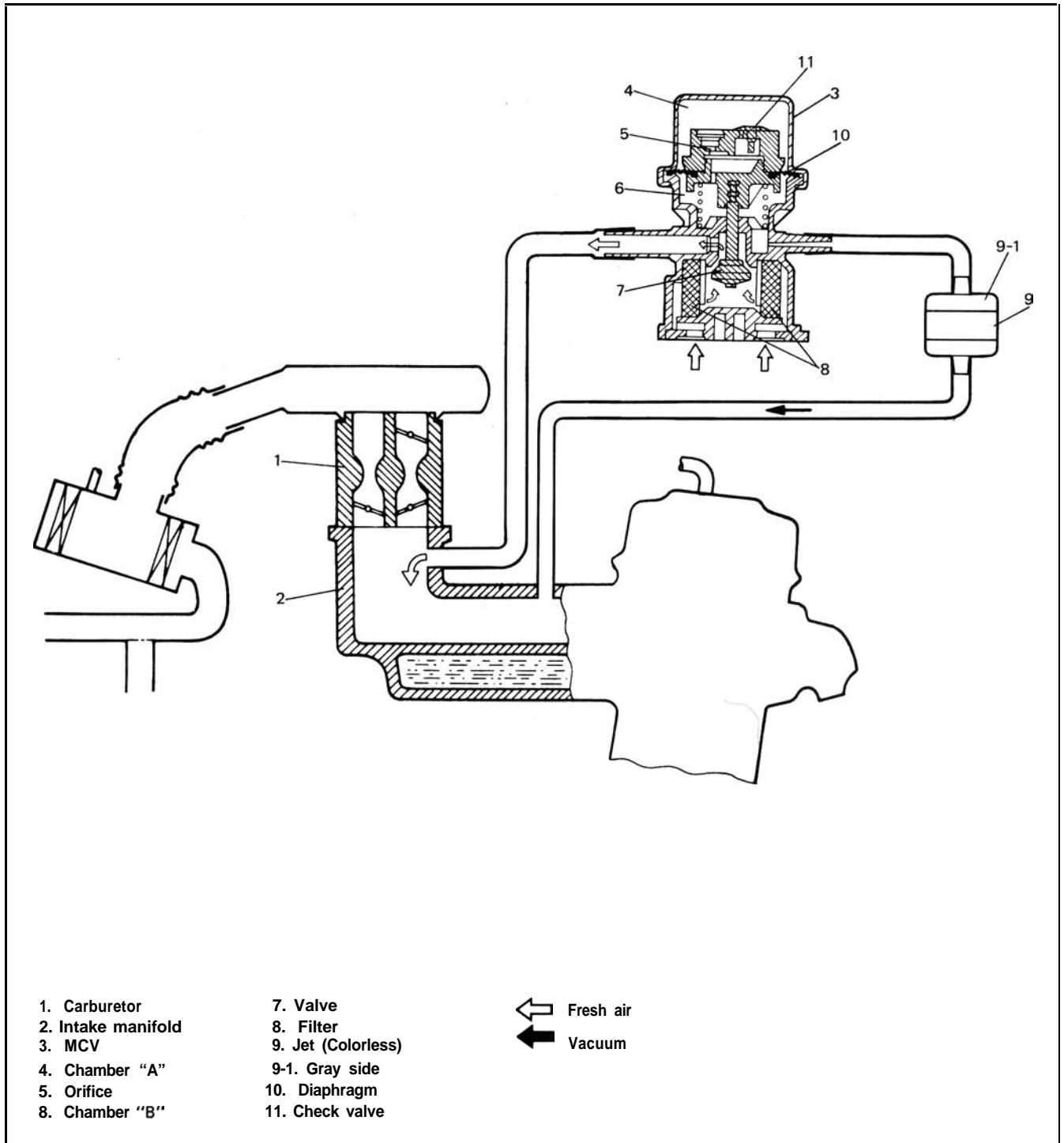


Fig. 5-1-7 Deceleration mixture control system

## COMPUTER CONTROLLED EMISSION CONTROL SYSTEM

### [Feed back system]

A prime purpose of this system is to maintain a controlled air fuel ratio, allowing the catalyst to reduce oxides of nitrogen, hydrocarbons, carbon monoxide and to improve fuel economy simultaneously.

The electronic control module (ECM) and the oxygen sensor are provided in this system.

The oxygen sensor mounted on the exhaust manifold monitors the exhaust gas air fuel ratio and signals to the ECM.

The ECM processes the oxygen sensor signal and controls carburetor air fuel ratio by the operation of the mixture control solenoid in the carburetor.

Thus the signal of the exhaust gas air fuel ratio sensed by the oxygen sensor is fed back to ECM and the carburetor air fuel ratio is controlled.

### [Electronic control module (ECM)]

The ECM controls the fuel cut system, idle-up system, bowl vent system, EGR system and secondary throttle valve system, as well as the feed back system. The ECM is located under the glove box of the instrument main panel. Refer to Fig. 5-1 -9.

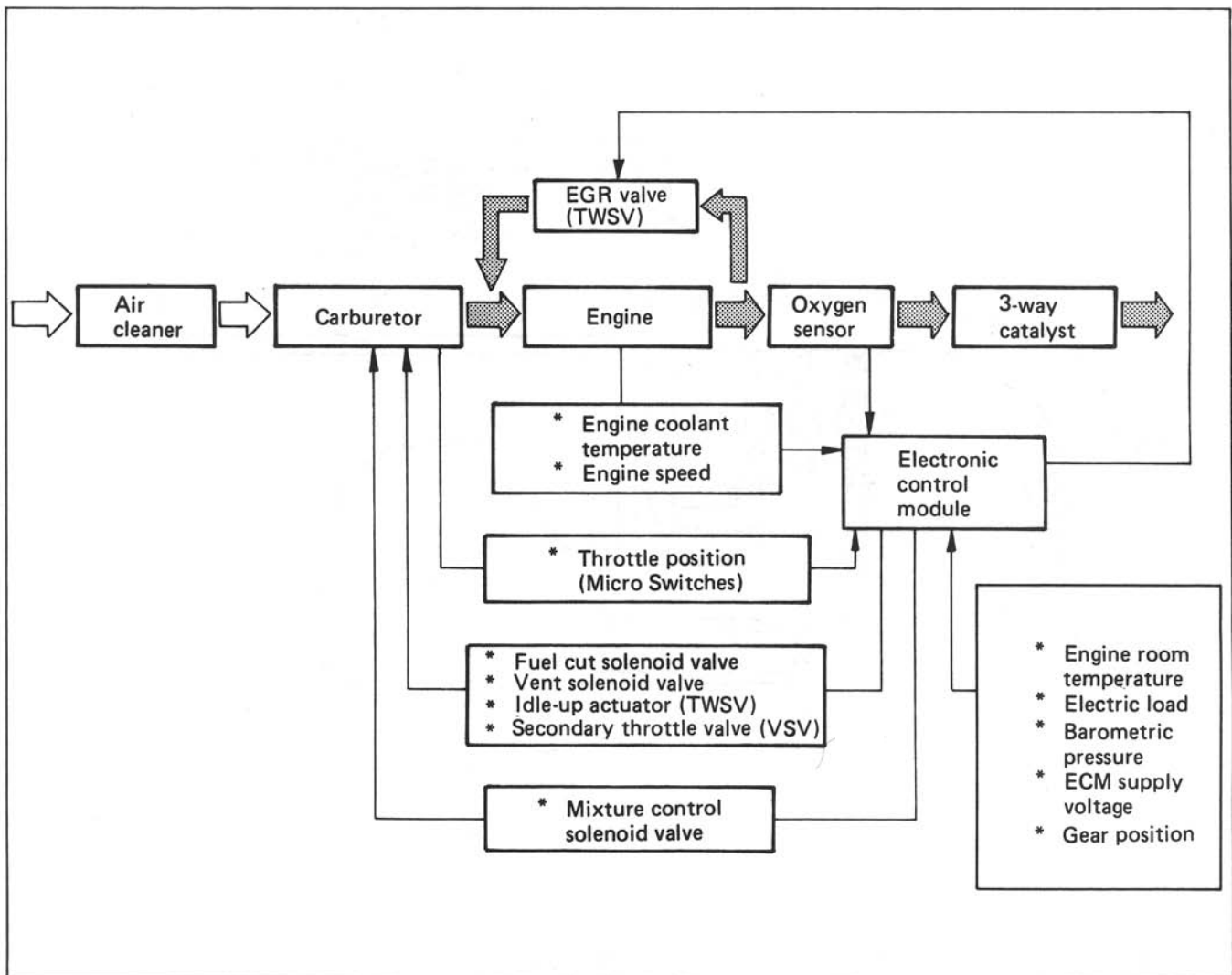
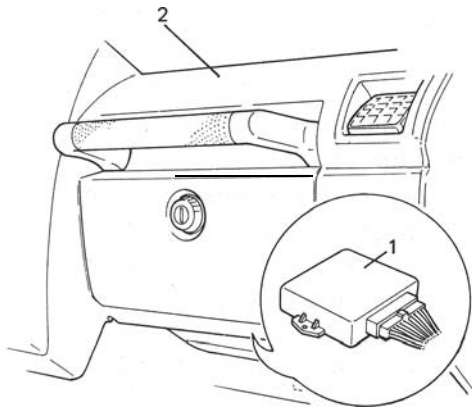


Fig. 5-1-8 Computer controlled emission control system



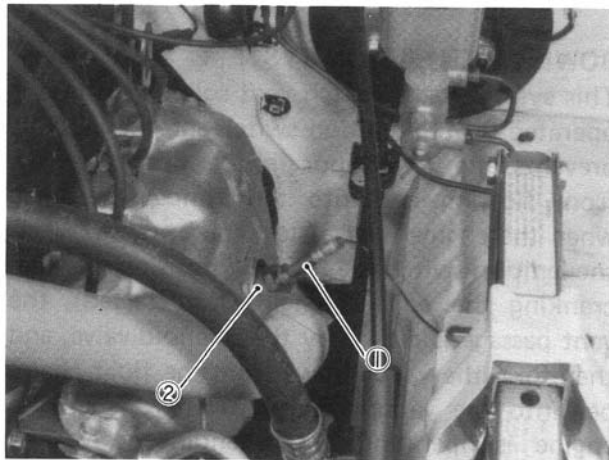


**Fig. 5-1-9 ECM**

- 1. ECM
- 2. Instrument panel

The ECM sensed parameters are as follows:

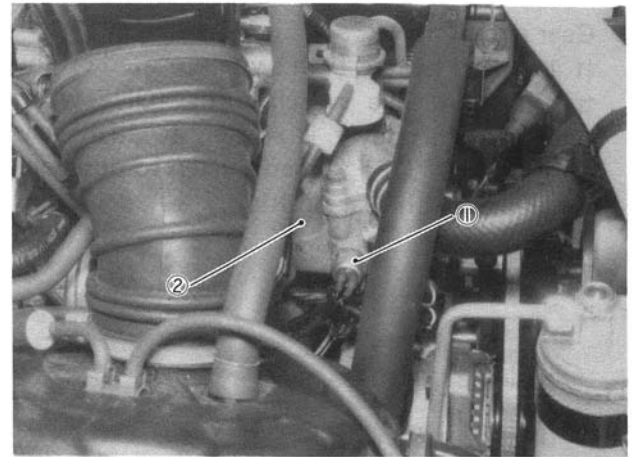
- Exhaust Oxygen Concentration.  
It is sensed by the oxygen sensor installed on the exhaust manifold.



**Fig. 5-1-10 Oxygen sensor**

- 1. Oxygen sensor
- 2. Exhaust manifold

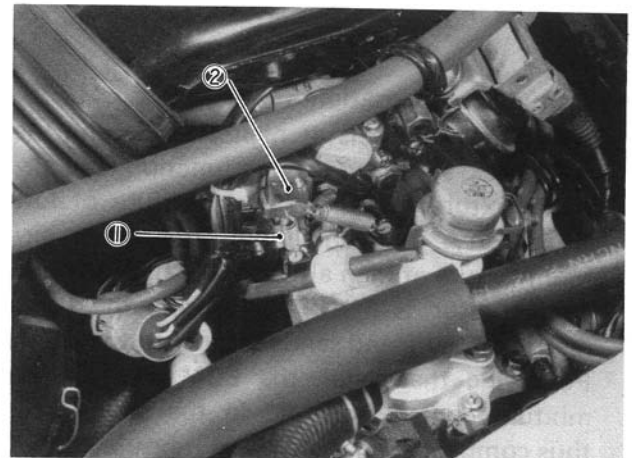
- Engine coolant temperature.  
It is sensed by the thermal switch installed on the intake manifold.



**Fig. 5-1-11 Thermal switch**

- 1. Thermal switch
- 2. Intake manifold

- Throttle position.  
It is sensed by the micro switches (wide open switch and idle switch) installed on the carburetor.

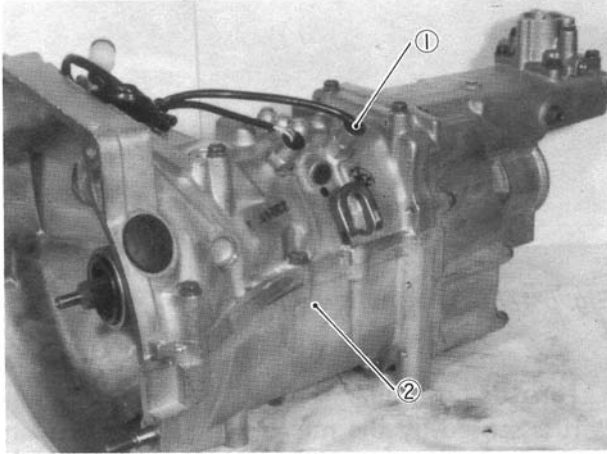


**Fig. 5-1-12 Micro switches**

- 1. Idle micro switch
- 2. Wide open micro switch

- Engine speed.  
It is computed by the ECM based on the electrical signal received from the ignition system.
- Electric load.  
The ECM senses electric loads of the following items to provide idle speed compensation.
  - a. Small, tail, side marker, license light.
  - b. Rear defogger (if equipped).
  - c. Heater fan.

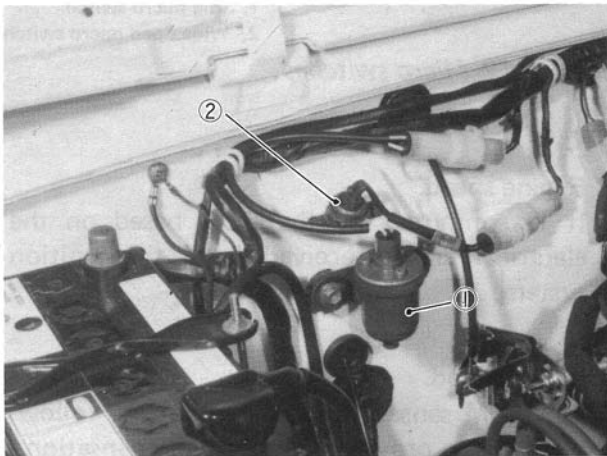
- Gear position.  
It is sensed by the fifth switch located on the transmission. The switch turns "ON" when the gear shift lever is shifted to fifth gear position and "OFF" when shifted to positions other than fifth gear position.



1. Fifth switch  
2. Transmission

**Fig. 5-1-13 Fifth switch**

- Altitude compensation.  
When the vehicle is at high altitude and the feed back system does not function, the air/fuel mixture becomes richer because of low air density. To compensate the richer air/fuel mixture at high altitude, the high altitude compensator is "ON" by sensing the barometric pressure and sends a signal to the ECM. Following the signal, the ECM controls the mixture control solenoid in the carburetor, thus compensating the air/fuel mixture.



1. High altitude compensator  
2. Thermal engine room switch

**Fig. 5-1- 14 High altitude compensator and thermal engine room switch**

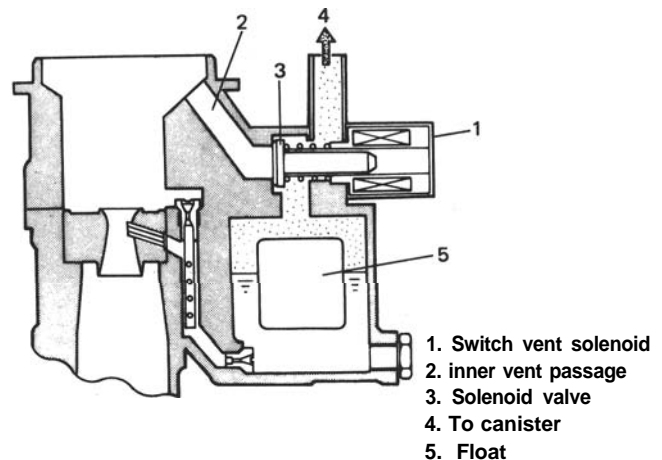
- Engine room temperature compensation.  
Sensing the air temperature in the engine room the thermal engine room switch sends an electric signal to ECM to compensate the air/fuel ratio of the mixture. When the air temperature in the engine room is low, the switch operates to make the mixture rich. When the air temperature in the engine room is high, the switch stops operating, which means, the air/fuel ratio of the mixture is not controlled by the switch. Refer to Fig. 5-1-1 for the thermal engine room switch.

[Three-way catalyst]

The three-way catalyst is provided in the exhaust system (exhaust center pipe). The function of the catalyst is to reduce the emission of CO, HC and NO<sub>x</sub> in the exhaust gas by oxidizing or converting them into CO<sub>2</sub>, H<sub>2</sub>O and N<sub>2</sub> respectively.

**BOWL VENTILATION SYSTEM**

This system has a switch vent solenoid which is operated by the ignition switch and the ECM. It prevents the fuel vapor in the float chamber from flowing out into the atmosphere both when the engine is at a stop and at work. When the ignition switch is at "OFF" position or when cranking the engine (engine not started), the vent passage is closed by the solenoid valve, and therefore, the vapor flows from the float chamber into the vapor storage canister. When the engine is operating, the solenoid receives an electrical signal from the ECM and its valve keeps the inner vent passage open. As a result, the vapor passes through the passage into the carburetor and is drawn into the engine.



1. Switch vent solenoid  
2. inner vent passage  
3. Solenoid valve  
4. To canister  
5. Float

**Fig. 5-1-15 Bowl ventilation system**

## FUEL CUT SYSTEM

As shown in the figure, the fuel cut solenoid valve is provided in the primary slow system of the carburetor to open and close the fuel passage of the slow system.

As turning the ignition switch "OFF" cuts off the electric current to the solenoid, the solenoid closes the fuel passage. Thus this system contributes to preventing dieseling of the engine after the ignition switch is turned "OFF". Also, during the deceleration and provided that all below listed three conditions exist, the fuel cut solenoid valve operates to cut the fuel feed to the engine temporarily by closing the fuel passage when it received a signal from the ECM.

Such operation of this system prevents the three-way catalyst from getting heated high and improves fuel economy.

Three conditions:

- The coolant temperature is normal.
- The idle micro switch is in "ON" position. In other words, the primary throttle valve is closed.
- The engine revolution is more than 2,400 rpm.

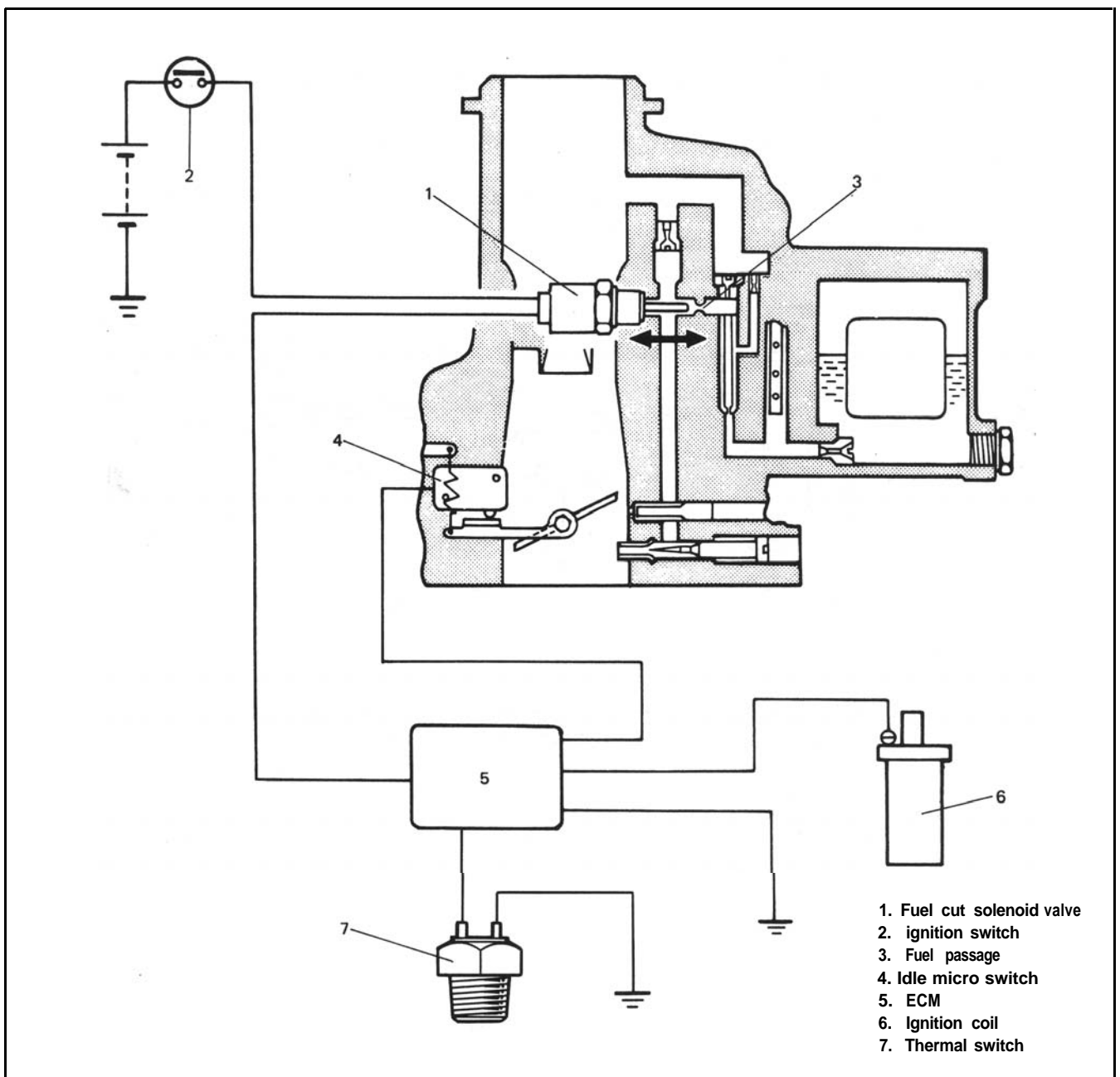


Fig. 5-1-16 Fuel cut system

## EXHAUST GAS RECIRCULATION (EGR) SYSTEM

This system controls the formation of NO<sub>x</sub> emission by recirculating the exhaust gas into the combustion chamber through the intake manifold.

The diaphragm mounted in the EGR modulator is operated by back pressure of the exhaust gas to open and close the valve. By this opening and closing action of the valve, the EGR modulator controls the vacuum transmitted to the EGR valve.

Under a low load condition such as low speed driving, the exhaust pressure is low. In this state, the diaphragm in the EGR modulator is pushed down by the spring force and the modulator valve opens to allow the air into the vacuum passage from the outside.

As a result, the vacuum transmitted to the EGR valve becomes smaller and so does the opening of the EGR valve. Thus, less amount of exhaust gas is recirculated to the intake manifold.

Under a high load condition such as high speed driving, on the other hand, the exhaust pressure is high. By the high exhaust pressure, the diaphragm in the modulator is pushed up and closes its valve. As the air does not enter the vacuum passage in this state, the vacuum transmitted to the EGR valve grows larger and so does the opening of the EGR valve. Thus, larger amount of exhaust gas is recirculated to the intake manifold.

Under any one of the following conditions, the vacuum passage is closed by the TWSV or BSVS and the vacuum is not transmitted to the EGR valve which, therefore, doesn't operate.

- When the coolant temperature is low. (BVSV is closed)
- When the gear shift lever is shifted to fifth gear position and fifth switch is turned on. (TWSV is closed)
- When HAC is turned on. (TWSV is closed)

Other than the above, EG R valve opens and closes in accordance with the EG R modulator operation.

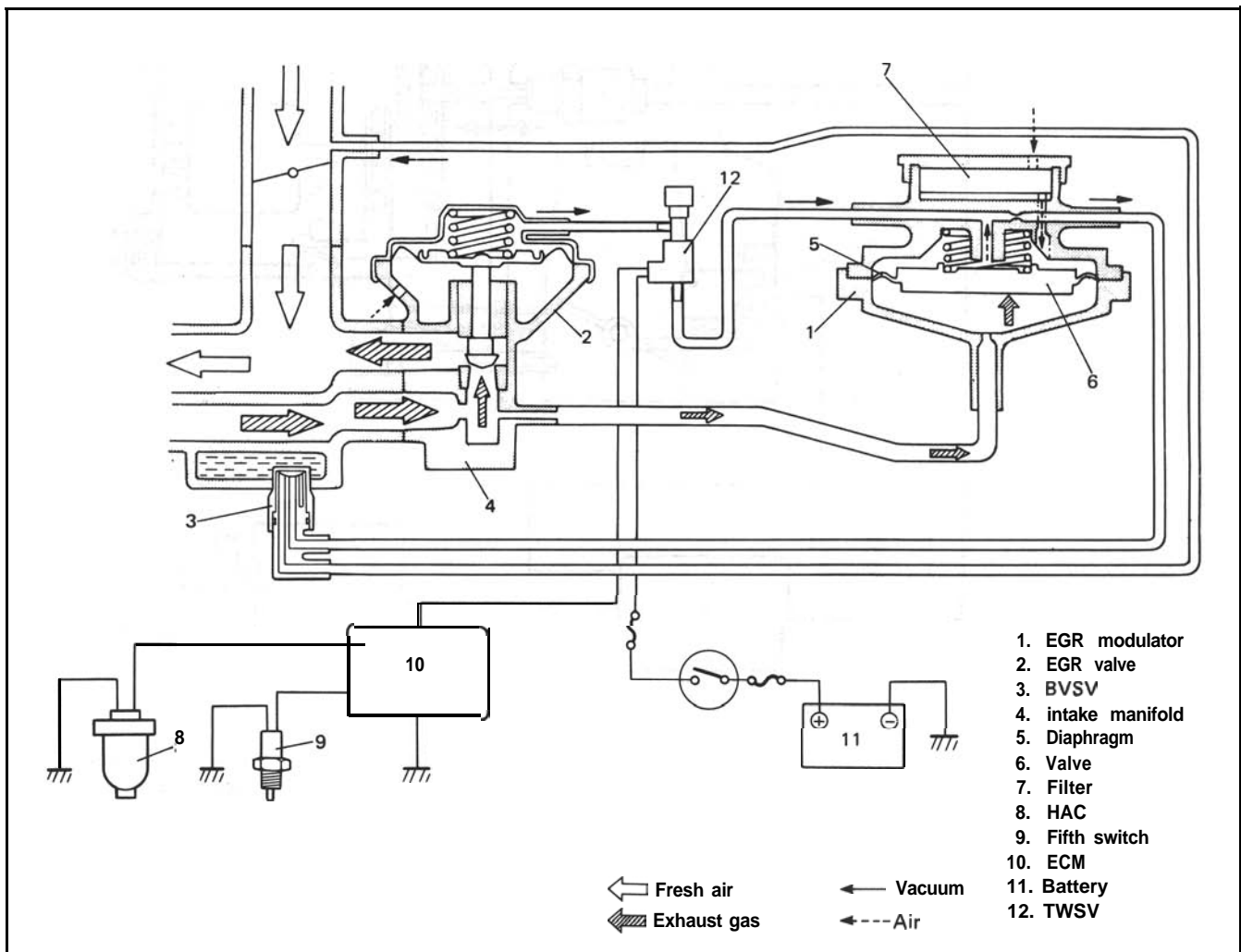


Fig. 5-1-17 EGR system operation

## 5-2. DIAGNOSIS

### POSSIBLE CAUSES OF EMISSIONS TEST FAILURES

Excessive Emission	Explanation	Possible Causes
Hydrocarbons (HC)	Excessive hydrocarbons are caused by an air/fuel mixture that is not burning completely.	<ul style="list-style-type: none"> <li>● Engine not at normal operating temperature</li> <li>● Disconnected, obstructed, leaking, or misrouted vacuum hoses</li> <li>● Vacuum leaks</li> <li>● Maladjusted idle mixture</li> <li>● Improper adjusted/sticking choke</li> <li>● Maladjusted initial spark timing</li> <li>● Defective spark plugs, wires or distributor cap</li> <li>● Malfunctioning MCV</li> <li>● Lead contamination of catalytic converter</li> <li>● Malfunctioning feed back system</li> </ul>
Carbon monoxide (CO)	Excessive carbon monoxide emissions are due to a mixture that is rich.	<ul style="list-style-type: none"> <li>● Engine not at normal operating temperature</li> <li>● Maladjusted idle mixture</li> <li>● Improperly adjusted/sticking choke</li> <li>● Lead contamination of catalytic converter</li> <li>● Leaking carburetor fuel passages or gaskets</li> <li>● Carburetor float level</li> <li>● Restricted air cleaner element</li> <li>● Malfunctioning feed back system</li> </ul>
Oxides of nitrogen (Nox)	Excessive oxides of nitrogen are generally due to high temperatures in the combustion chamber.	<ul style="list-style-type: none"> <li>● Obstructed/leaking/misrouted vacuum lines</li> <li>● Improper operation of the EGR system</li> <li>● Plugged EGR passages</li> <li>● Inoperative BVSV or TWSV</li> <li>● Lead contamination of catalytic converter</li> <li>● Malfunctioning feed back system</li> </ul>

## EGR DIAGNOSIS

Condition	Possible Cause	Correction
<p>Engine idles abnormally rough and/or stalls.</p>	<p>EGR valve vacuum hoses mis-routed.</p> <p>Leaking EGR valve.</p> <p>EGR valve gasket failed or loose EGR attaching bolts.</p> <p>Improper vacuum to EGR valve at idle.</p> <p>Sticky EGR valve</p>	<p>Check EGR valve vacuum hose routing. Correct as required.</p> <p>Check EGR valve for correct operation.</p> <p>Check EGR attaching bolts for tightness. If no loose, remove EGR valve and inspect gasket.</p> <p>Check vacuum from carburetor EGR port with engine at stabilized operating temperature and at idle speed.</p> <p>Check EGR valve for correct operation,</p>
<p>Engine runs rough on light throttle acceleration and has poor part load performance.</p>	<p>EGR valve vacuum hose mis-routed.</p> <p>Loose EGR attaching bolts</p> <p>Sticky or binding EGR valve.</p> <p>EGR modulator valve blocked or air flow restricted.</p> <p>Wrong or no EGR gasket.</p>	<p>Check EGR valve vacuum hose routing. Correct as required.</p> <p>Torque bolts.</p> <p>Same as listing in "Engine idles Abnormally Rough and/or Stalls" condition.</p> <p>Clean EGR passage deposits.</p> <p>Perform EGR System Check.</p> <p>Check EGR modulator valve operation.</p> <p>Install new gasket, torque attaching parts.</p>
<p>Engine stalls on decelerations.</p>	<p>EGR modulator valve blocked of air flow restricted.</p> <p>Restriction in EGR vacuum line.</p> <p>VSV filter plugged.</p> <p>Sticking or binding EGR valve.</p>	<p>Check EGR modulator valve operation.</p> <p>Check EGR vacuum lines for kinks, bends, etc. Remove or replace hoses as required.</p> <p>Check VSV for correct operation.</p> <p>Check EGR valve for excessive deposits causing sticky or binding operation.</p>
<p>Part throttle engine detonation.</p> <p><b>NOTE:</b> Non-functioning EGR valve could contribute to part throttle detonation. Detonation can be caused by several other engine variables. Perform ignition and carburetor related diagnosis.</p>	<p>EGR modulator valve blocked of air flow restricted.</p> <p>Insufficient exhaust gas recirculation flow during part throttle accelerations.</p>	<p>Check internal control valve operation.</p> <p>Check EGR valve hose routing. Check EGR valve operation. Repair or replace as required. Replace valve as required. Check EGR passages and valve for excessive deposit. Clean as required. Check VSV operation.</p>

Condition	Possible Cause	Correction
Engine starts but immediately stalls when cold.  <b>NOTE:</b> <b>Stalls after start can also be caused by carburetor problems.</b>	EGR valve hoses misrouted.  BVSV is out of order.	Check EGR valve hose routings.  Check BVSV. Replace as necessary.

### PCV SYSTEM DIAGNOSIS

Condition	Possible Cause	Correction
Unstable idle, frequent stalling.  Oil in air cleaner.	PCV valve completely stuck. Hose plugged.  PCV system plugged.	Replace valve. Check hoses.  Replace valve.

## 5-3. MAINTENANCE SERVICE

### GENERAL

If the emission control hoses were disconnected and any system component was removed for service, be sure to reinstall the component properly and route and connect hoses correctly after service. Refer to Fig. 5-1-1 for hose connection.

### PCV SYSTEM

#### Checking PCV System

##### NOTE:

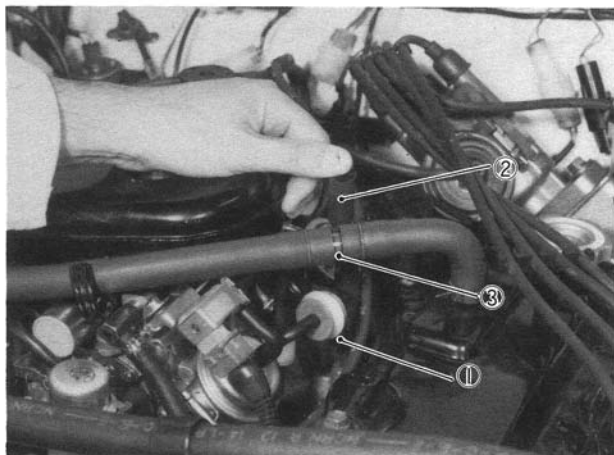
If the engine is idling rough, this may be caused by a stuck PCV valve, plugged hoses or vacuum leakage of PCV line, therefore, never adjust the carburetor idle without first checking the PCV valve and hoses.

##### [ PCV hoses]

Check hoses for connection, leakage, clog, and deterioration. Replace as necessary.

##### [ PCV valve]

- 1) Disconnect PCV hoses at three way joint.
- 2) Run engine at idle.
- 3) Place your thumb over the end of disconnected PCV hose to check for vacuum. If there is no vacuum, check for clogged hose or valve. Replace as necessary.



1. PCV valve
2. PCV hose
3. Three way joint

**Fig. 5-3- 1 Checking vacuum**

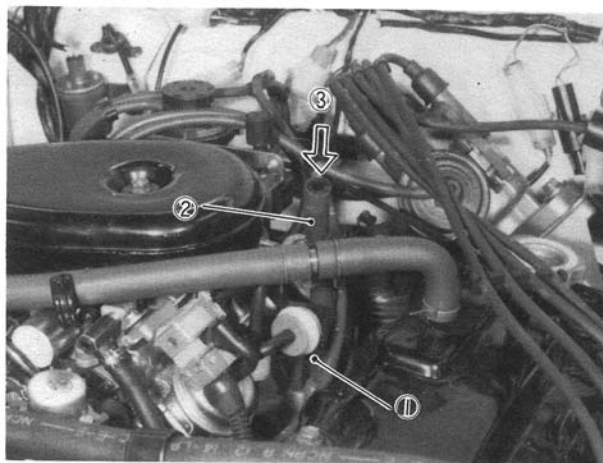
- 4) After checking vacuum, stop engine and check PCV valve for sticking.

With engine stopped, remove PCV hose and connect a new hose to PCV valve.

Blow air into new hose and check that air flows with difficulty from cylinder head side to intake manifold side. If air flows without difficulty, the valve is stuck in "Open" position. Replace PCV valve. Before installing new PCV valve to intake manifold, wind sealing tape on thread of the valve.

##### WARNING:

Do not suck air through PCV valve. The petroleum substances inside the valve and fuel vapor inside intake manifold are harmful.



1. PCV valve
2. New PCV hose
3. Blow air

**Fig. 5-3-2 Checking PCV valve for sticking**

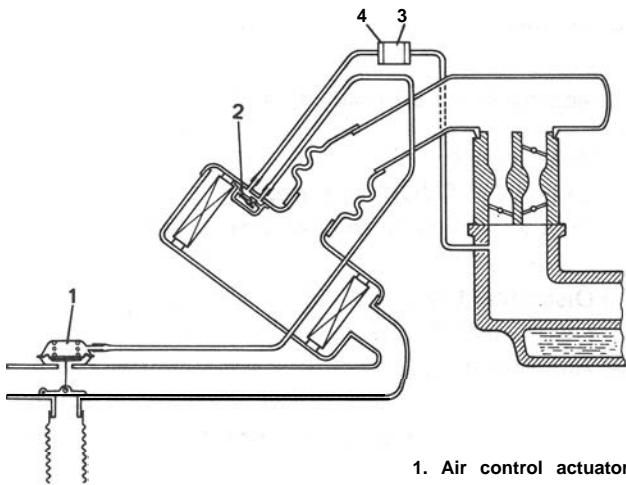
- 5) Connect PCV hose securely.



## TCAC SYSTEM

### Checking TCAC System

- 1) Check vacuum hose for connection, deterioration or damage. Replace as necessary.



1. Air control actuator
2. Thermo sensor
3. Check valve
4. Orange side

Fig. 5-3-3 TCA C sys tern

- 2) With engine at a stop, make sure that the valve indicated in figure is completely closed (closing warm air side). This check should be carried out by putting finger into duct after removing warm air hose from it.

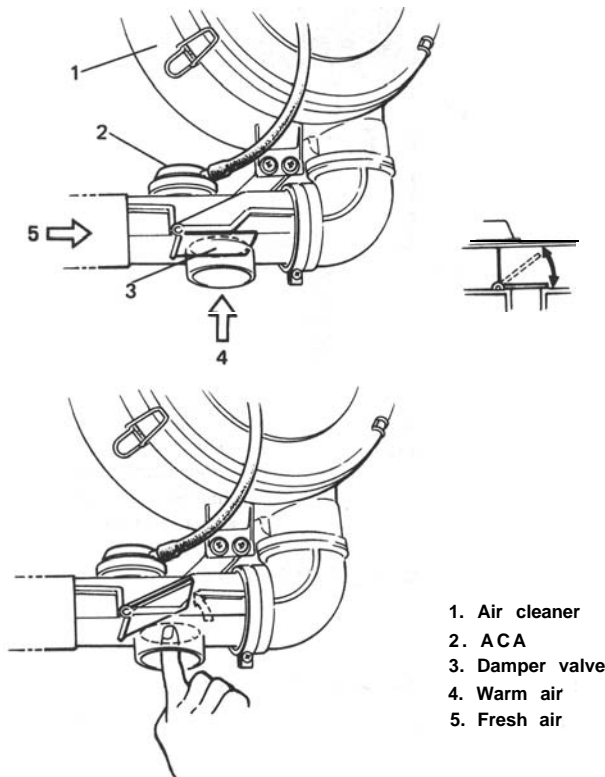


Fig. 5-3-4 Checking TCA C sys tern

- 3) Check that when engine is started (and run at idle speed) under the condition that air cleaner is cool, valve on warm air side becomes fully open and one on fresh air inhaling side is completely closed.
- 4) If nothing was found faulty in the above step, connect warm air hose.

If found defective in above step 2) or 3), inspect following parts according to each procedure.

#### [Air control actuator]

- 1) Disconnect vacuum hose from thermo sensor.
- 2) Make sure that damper opens fully when more than 20 cmHg (7.87 in.Hg) vacuum is applied to ACA.

Also, make sure that damper is held at the same position when a constant vacuum is applied to it.

If damper doesn't open or close smoothly, or it isn't held at the same position, replace ACA.

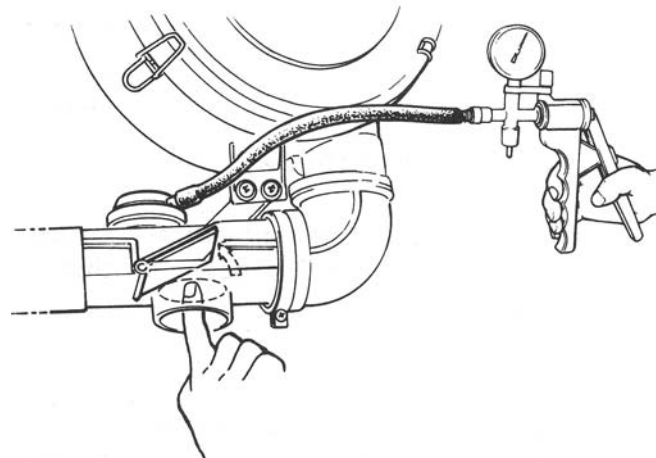


Fig. 5-3-5 Checking A CA

#### [Thermo sensor]

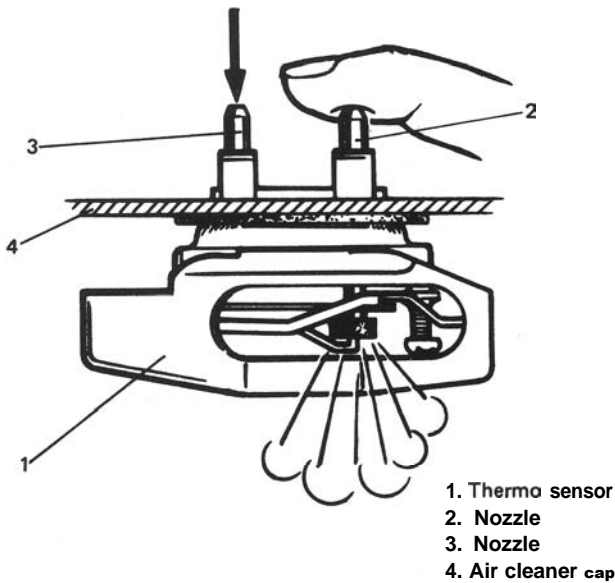
- 1) Remove air cleaner case cap.
- 2) Disconnect two vacuum hoses from thermo sensor.
- 3) Measure the temperature around thermo sensor.
- 4) Close a nozzle with finger and then blow air into nozzle. If measured temperature is above 40°C (104° F), air should come out of thermo sensor valve (valve is open) as shown in Fig. 5-3-6.

If the temperature is below 25°C (77° F), air should not come out (valve is closed).

Replace defective parts.

**NOTE:**

- To check thermo sensor for operation at higher than 40°C (104° F) temperature when thermo sensor is lower than 25°C (77° F), remove thermo sensor from air cleaner cap and warm it up with hair drier or photo light before checking.
- Never touch bimetal or valve in thermo sensor.

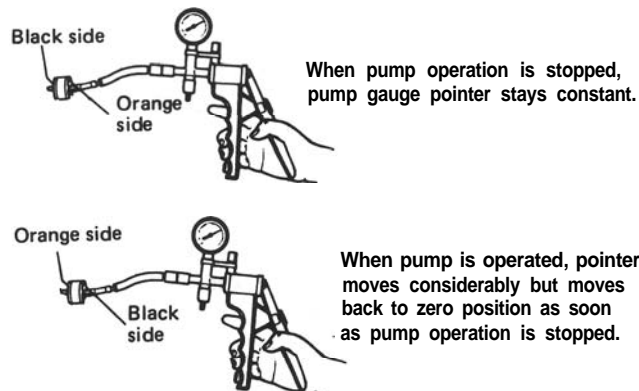


**Fig. 5-3-6 Checking thermo sensor**

- 5) After checking, reinstall air cleaner case cap, and connect 2 vacuum hoses to thermo sensor.

**[Check valve]**

- 1) Remove check valve with vacuum hose.
- 2) Using vacuum pump gauge, check for the following.



**Fig. 5-3-7 Checking check valve**

If found defective, replace.

- 3) Install check valve with its orange side directed toward thermo valve.

**EVAPORATIVE EMISSION CONTROL SYSTEM**

**Checking vapor storage canister**

**WARNING:**  
**DO NOT SUCK** the nozzles on canister. Fuel vapor inside the canister is harmful.

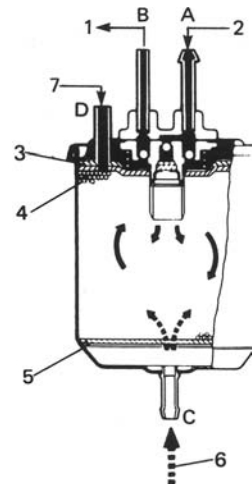
- 1) Disconnect negative cable at battery.
- 2) Disconnect 3 hoses from canister.
- 3) Remove canister.

air into pipe A strongly, and air should come out from pipe B.

pass through pipe A, C or D.

- 6) When air is blown into pipe C, air should come out from pipe A, B and D.

If operation differs from above description, canister must be replaced.



1. Vapor to carburetor
2. Vapor from fuel tank
3. Filter
4. Charcoal
5. Filter
6. Air flow under vacuum condition
7. Vapor from float chamber when ignition switch is "OFF"

**Fig. 5-3-8 Checking canister**

- 7) Install canister and connect hoses and battery negative cable.

[Hoses]

Visually inspect hoses and pipe for cracks, damage, or excessive bends, and hose connection for tightness.

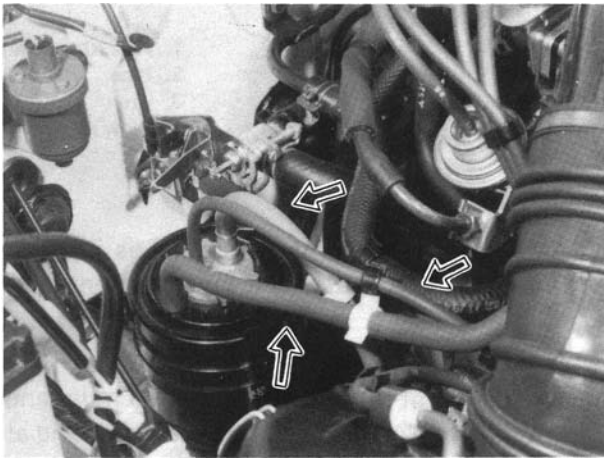


Fig. 5-3-9

### HOT IDLE COMPENSATOR (HIC)

#### Checking Hot Idle Compensator

- 1) Remove air intake case with hose.
- 2) Check temperature around HIC with thermometer.
- 3) If temperature is below 45°C (113° F), air should not come out of HIC when air is blown into hose. If temperature is above 65°C (149° F), air comes out of HIC. Replace HIC if defective.
- 4) After checking, install air intake case and connect hose to intake manifold.

#### NOTE:

- To check HIC for operation at higher than 65°C (149°F) temperature when HIC (bi-metal) temperature is lower than 45°C (113° F), warm it up with hair drier or photo light before checking.
- Never touch bimetal or valve in HIC.

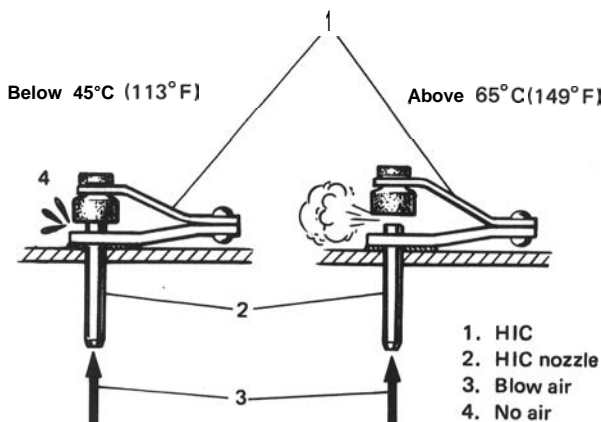


Fig. 5-3-10

### DECELERATION MIXTURE CONTROL SYSTEM

#### Checking

[Hoses]

Inspect each hose for pinholes, cracks or damage. Also check to ensure that each joint is securely connected. Any part found defective must be corrected or replaced.



Fig. 5-3-11

[Mixture control valve (MCV)]

- 1) Warm up the engine to normal operating temperature.
- 2) Disconnect hose ① and reconnect it. At this time, check that air is drawn into MCV.

#### NOTE:

At this time, the engine will idle rough or die, but this is normal.

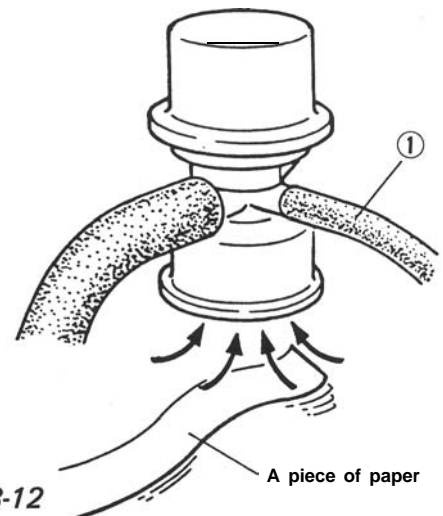
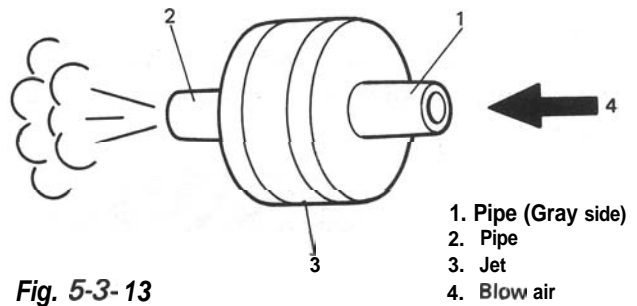


Fig. 5-3-12

If the above checks show anything wrong, replace it.

**[Jet]**

- 1) Remove jet.
- 2) When blowing air into pipe ①, air should come out of pipe ②.  
Replace clogged jet.
- 3) Install jet with its gray side directed toward **MCV**.



**Fig. 5-3-13**

**FEED BACK SYSTEM**

Whether feed back system including oxygen sensor and ECM (Electronic Control Module) is in good condition or not, can be judged by checking for operation of "CHECK ENGINE" light in instrument cluster.

[U.S.A. specification vehicle]

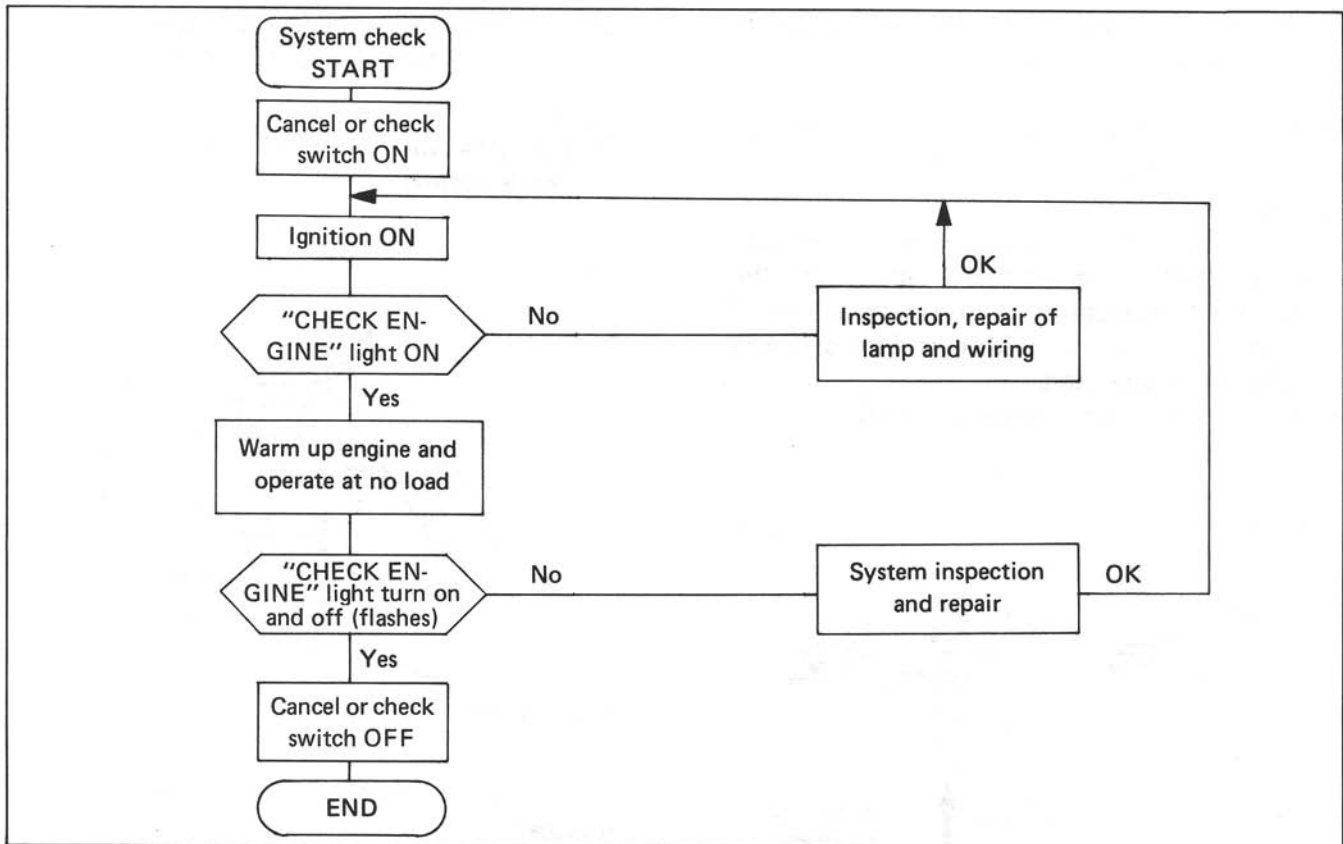
As previously outlined, "CHECK ENGINE" light automatically flashes at 50,000 miles, 80,000 miles and 100,000 miles indicated on odometer when running warmed up engine. And this automatic flashing at above mileages proves that system is in good condition.

Should any of following malcondition occur, the system check can be performed according to "System check flow chart", even when mileage indicated by odometer is not any of 50,000 miles, 80,000 miles and 100,000 miles.

[Canadian specification vehicle]

Should any of following malconditions occur, the system check can be performed according to "System check flow chart".

- Fuel consumption increases **excessively** even in normal driving.
- Engine tends to stall.
- Engine is hard to start.



**Fig. 5-3-14 System check flow chart**

### Checking feed back system

- 1) Operate (turn ON) cancel switch or check switch located at the place shown in below figure.

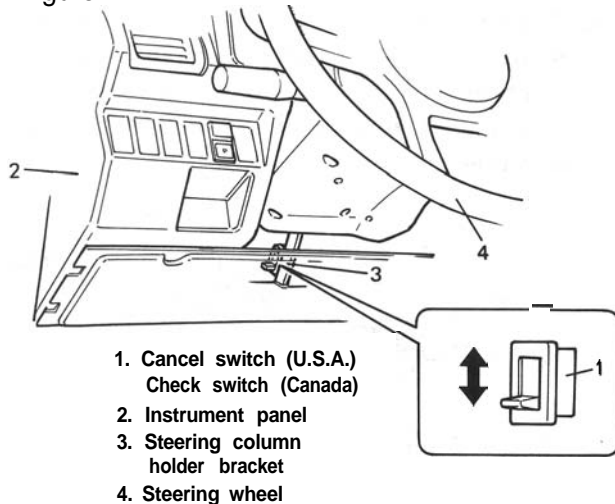


Fig. 5-3-15 Cancel switch or check switch

- 2) Turn ignition switch ON without running engine.

At this time, "CHECK ENGINE" light should light (should not flash).

If it does not light, check electric circuit of the light, namely light for blow off and lead wire for disconnection.

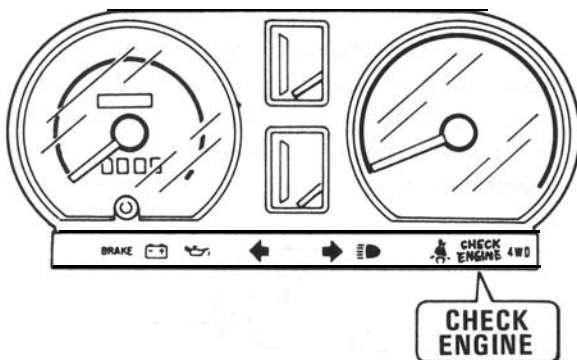


Fig. 5-3-16 "CHECK ENGINE" light

- 3) After lighting of the light is confirmed, start engine and warm it up to normal operating temperature.
- 4) When engine is warmed up, run engine at 1,500 – 2,000 rpm. In this state, make sure that "CHECK ENGINE" light flashes. Flashing of light proves that system is in good condition. If light does not flash, it can be caused by one of the following. Check them and replace or adjust as necessary.

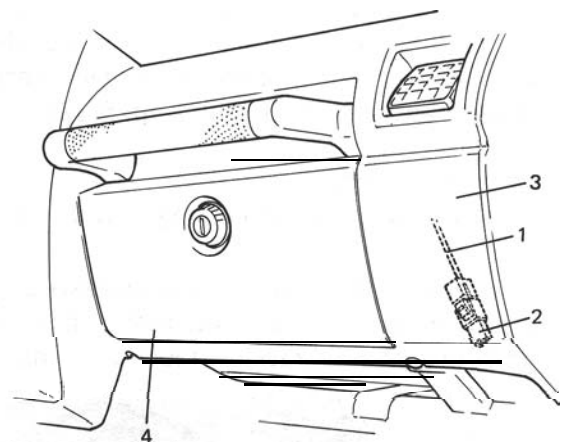
- Defective oxygen sensor
  - Defective mixture control solenoid valve
  - Defective carburetor or maladjusted idle mixture
  - Defective thermal switch
  - Disconnected or loosely connected electric lead wires of emission control systems
  - Defective ECM
  - Defective micro switches (idle and wot)
- 5) After making sure that "CHECK ENGINE" light flashes, turn cancel switch OFF. Light should go off.
  - 6) Stop engine.

### Checking idle and wide open micro switches

Check idle and wide open micro switches according to the following procedures.

1. Warm up engine to normal operating temperature and stop engine.
2. For this check, use check terminal coming from the lower right of instrument panel as shown.

Connect negative prod of ohmmeter to check terminal and positive prod to body.



- |                     |                     |
|---------------------|---------------------|
| 1. Light green wire | 3. Instrument panel |
| 2. Check terminal   | 4. Glove box lid    |

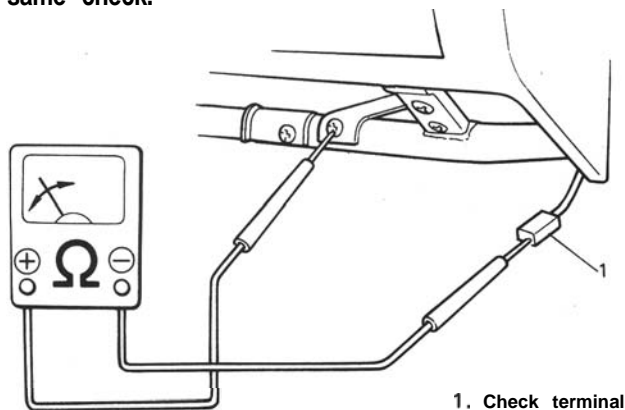
Fig. 5-3-17

3. Turn ignition switch to "ON" position.
4. Observe ohmmeter indicator reaction to make sure for the following movement for each throttle valve position.

THROTTLE VALVE POSITION	INDICATOR MOVEMENT
Idle position	Swing
1/2 open	Stay after deflection
Full open	Swing

**NOTE:**

If indicator doesn't deflect at all, reverse above connection, that is, negative prod to body and positive one to check terminal, and carry out the same check.



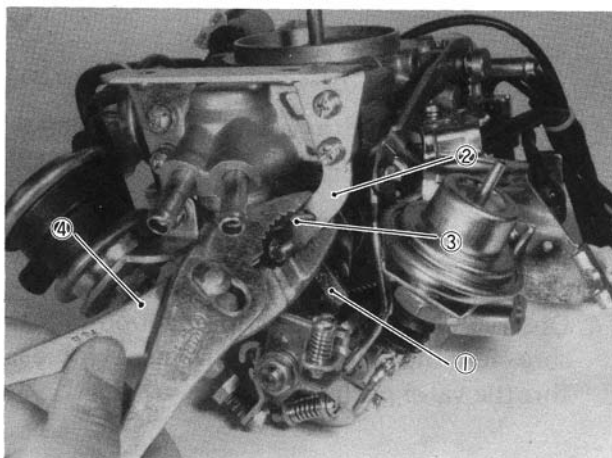
1. Check terminal

**Fig. 5-3- 18**

If check results are not satisfactory, check idle and wide open micro switches as follows or their circuits for continuity referring to item "checking sensors and their lead wires" (p. 5-32).

[Idle micro switch]

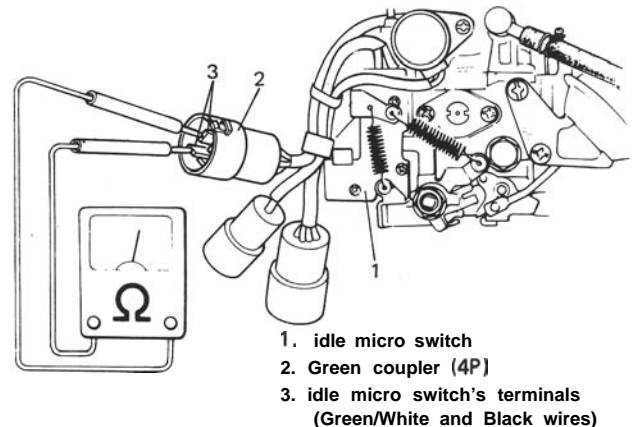
- 1) Remove carburetor following normal service procedures.
- 2) Turn fast idle cam counterclockwise and insert a suitable pin available then into holes in **cam** and bracket to lock the cam.



1. Fast idle cam      3. Pin  
2. Bracket            4. Plier

**Fig. 5-3- 19**

- 3) Connect ohmmeter to terminals of idle micro switch. Check for continuity between terminals. When throttle valve is at idle position, ohmmeter should indicated "zero" ohm.
- 4) Open throttle valve by 1/4 to 1/2, and ohmmeter indicator should indicate infinity. If check results in steps 3) and 4) are not satisfactory, replace idle micro switch with a new one.

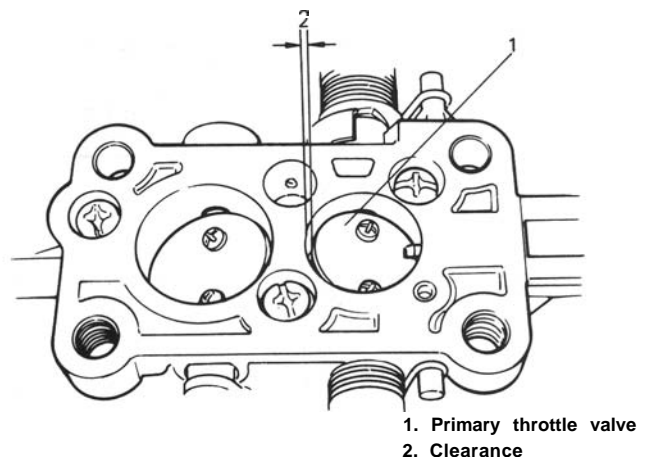


1. idle micro switch  
2. Green coupler (4P)  
3. idle micro switch's terminals (Green/White and Black wires)

**Fig. 5-3-20 Connecting ohmmeter to idle micro switch**

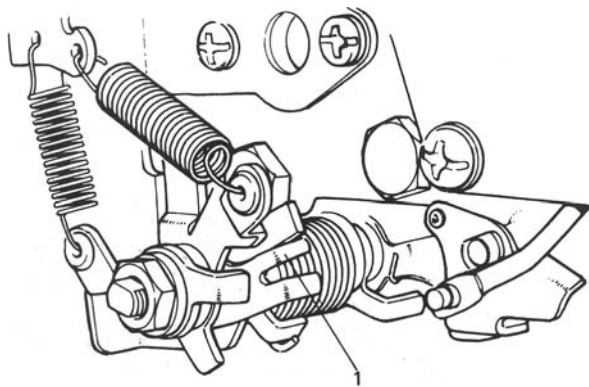
- 5) Open throttle valve slowly till throttle valve-to-carburetor bore clearance becomes 0.36 — 0.62 mm (0.014 — 0.024 in) and check that ohmmeter indicator moves from "zero" ohm to infinity then.

If the above indicator movement does not occur within specified range, make adjustment by bending lever shown in below figure. Bend lever down when clearance is below specification and up when over specification.



1. Primary throttle valve  
2. Clearance

**Fig. 5-3-21 Clearance between throttle valve and carburetor bore**

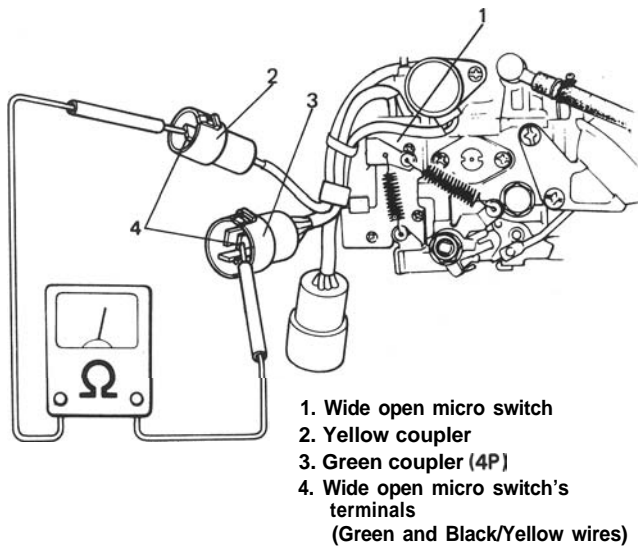


1. Lever

**Fig. 5-3-22 Lever**

[Wide open micro switch]

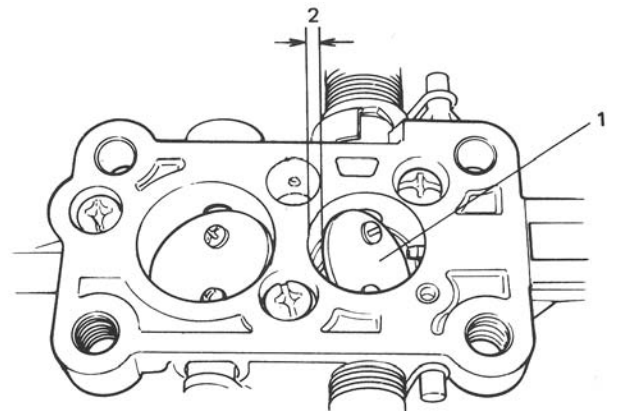
- 1) Connect ohmmeter to wide open micro switch as indicated in below figure. At this time, ohmmeter indicator should indicate "zero" ohm.
- 2) When throttle valve is fully opened, ohmmeter should indicate infinity. If any defect, replace.



1. Wide open micro switch  
 2. Yellow coupler  
 3. Green coupler (4P)  
 4. Wide open micro switch's terminals  
 (Green and Black/Yellow wires)

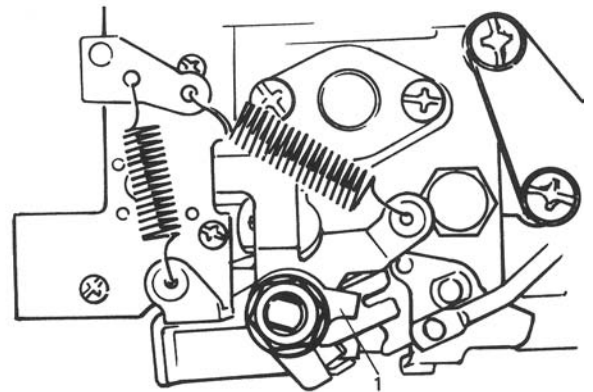
**Fig. 5-3-23 Checking wide open micro switch**

- 3) Open throttle valve gradually until the ohmmeter indicates infinity. Then, using a vernier, measure the clearance between throttle valve and carburetor bore as shown in below figure. The clearance should be within 6.0 – 7.2 mm (0.24 – 0.28 in). If the clearance is out of specified range, make adjustment by bending the lever in below figure.



1. Primary throttle valve  
 2. Clearance

**Fig. 5-3-24 Clearance between throttle valve and carburetor bore**



1. Wide open micro switch lever

**Fig. 5-3-25 Wide open micro switch lever**

Upon completion of checks, install carburetor following normal service procedures.

**Checking mixture control solenoid valve**

- 1) Check to make sure that ignition switch is at "OFF" position.
- 2) Disconnect couplers from ECM, TWSVs and VSV.
- 3) Disconnect mixture control solenoid valve lead wires at the coupler (5P).



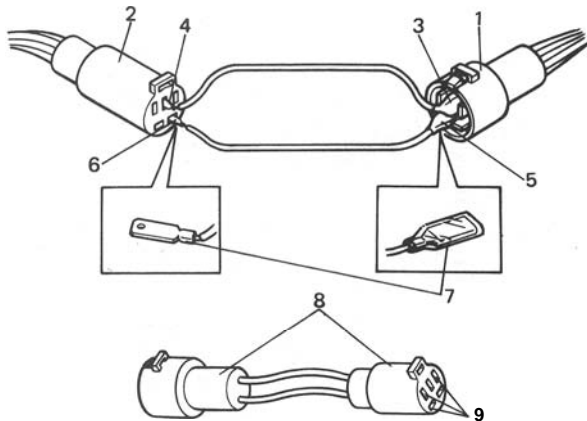
1. Green coupler (5P)

**Fig. 5-3-26**

- 4) Using couplers of the same shape as that mentioned in step 3) or 1P couplers, connect only mixture control solenoid valve wire terminals (Yellow/Black terminal of coupler ① and Black/White terminal of coupler ②, White terminal of coupler ① and Blue/Red terminal of coupler ②).

**NOTE:**

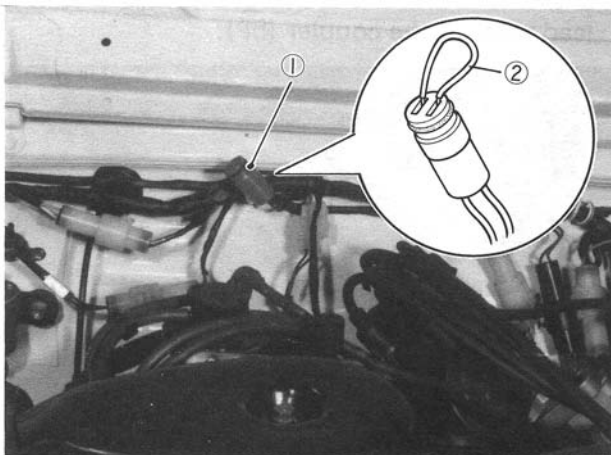
- Couplers must be used to connect each terminal.
- Use special care when connecting terminals as wrong connection may cause damage to other parts.



- |                                 |  |
|---------------------------------|--|
| 1. Coupler of MCSV side         | 7. 1 p coupler   |
| 2. Coupler of wire harness side | 8. 5p coupler (when using this coupler, leave positions indicated as 9 in figure blank). |
| 3. Yellow/Black wire terminal   | 9. Blank   |
| 4. Black/White wire terminal    |  |
| 5. White wire terminal          |  |
| 6. Blue/Red wire terminal       |  |

Fig. 5-3-27

- 5) Remove cap of duty check coupler located on dash panel and connect terminals with a lead wire to short them.



- |                       |
|-----------------------|
| 1. Duty check coupler |
| 2. Lead wire          |

Fig. 5-3-28

- 6) Turn ignition switch "ON" and "OFF" repeatedly (without starting engine) and check if MCSV operating sound is heard as ignition switch is operated.

Operating sounds prove its proper operation.

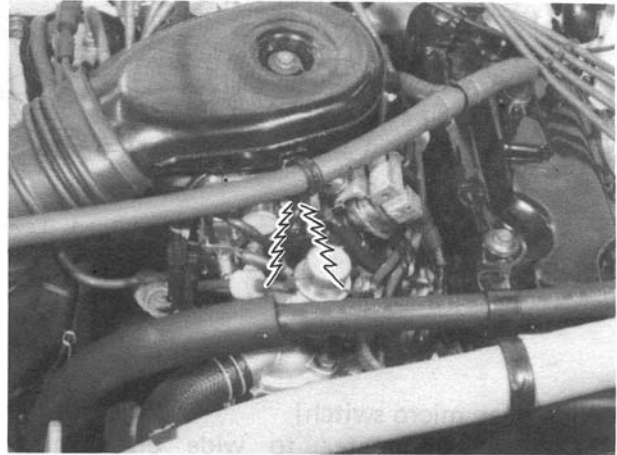


Fig. 5-3-29

- 7) Upon completion of checks, re-connect disconnected couplers to original positions securely.

**Checking thermal switch**

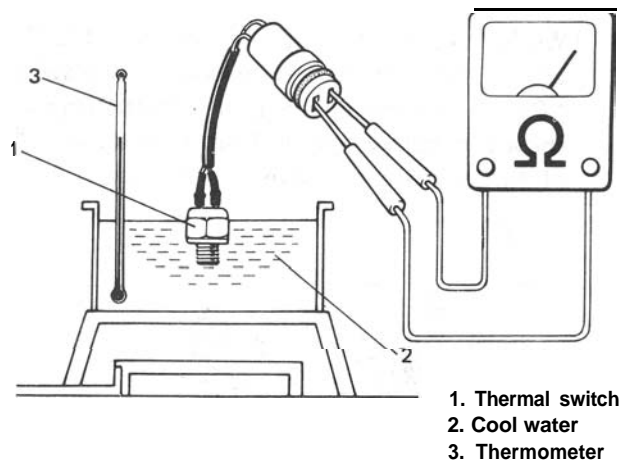
**NOTE:**

For the rough check of the operation, thermal switch can be checked by warming up (above 46.5°C, 116°F) or cooling down (below 30°C, 86°F) the engine without being removed from the intake manifold.

The check procedure is the same as the following except item 1), 2), 5) and 6).

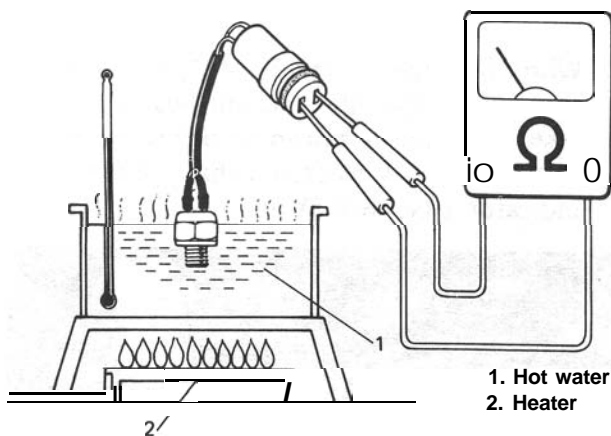
- 1) Drain cooling system.
- 2) Remove thermal switch from intake manifold.
- 3) Cool switch to below 30°C (86° F), and using an ohmmeter, check that there is continuity between terminals.





**Fig. 5-3-30** Checking thermal switch in cool water

- 4) Heat switch to above 46.5°C (116°F), and check that there is no continuity between terminals.

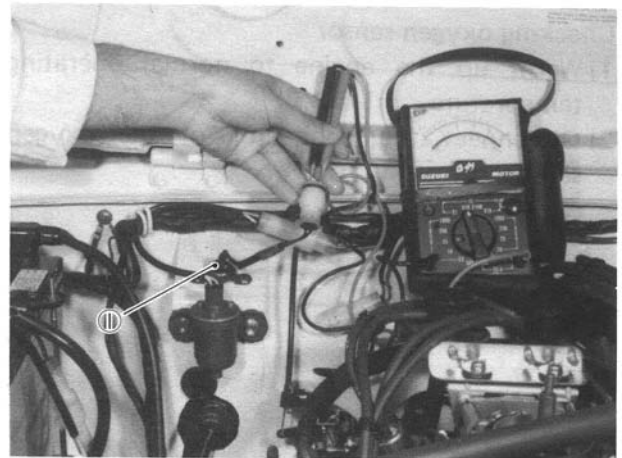


**Fig. 5-3-31** Checking switch in hot water

- 5) Reinstall switch to intake manifold. Before installing, wind sealing tape on its thread.  
6) Refill cooling system.

**Checking thermal engine room switch**

- 1) Disconnect connector of switch and connect ohmmeter between terminals on switch side.
- 2) Make sure that switch is "ON" (ohmmeter indicates "Zero" ohm) when atmospheric temperature is below 7°C (44° F) and "OFF" (ohmmeter. indicates infinity) when above 19.5°C (67° F).



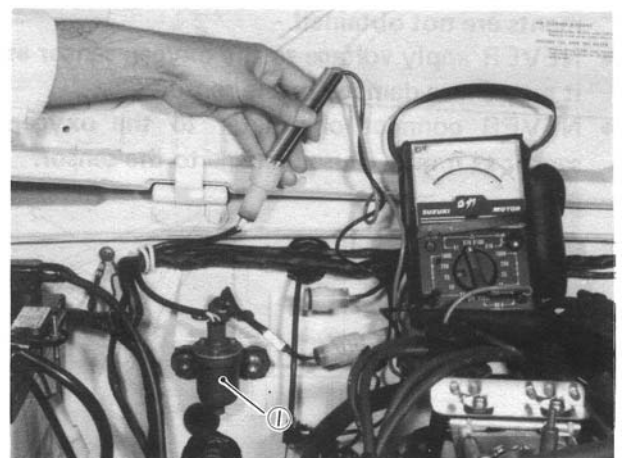
1. Thermal engine room switch

**Fig. 5-3-32** Checking thermal engine room switch

**Checking high altitude compensator**

Check the compensator as follows:

- 1) Disconnect the coupler of compensator and connect an ohmmeter to the compensator.
- 2) Check to be sure that;
  - If the altitude of the place where this check is performed is above 1,220 m (4,000 ft), the ohmmeter should indicate "Zero" ohm (compensator is ON).
  - If the altitude is below 1,220 m (4,000 ft), the ohmmeter should indicate infinity ohm (compensator is OFF).
- 3) After checking, connect the coupler.



1. High altitude compensator

**Fig. 5-3-33** Checking high altitude compensator

### Checking oxygen sensor

- 1) Warm up the engine to normal operating temperature.
- 2) Disconnect the connector of the oxygen sensor.

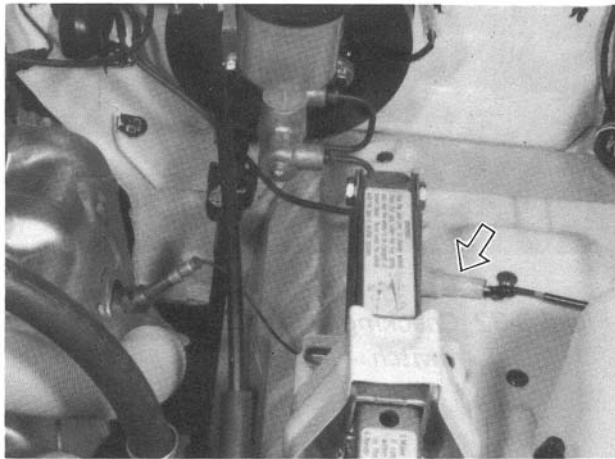


Fig. 5-3-34 Connector of oxygen sensor

- 3) Connect the voltmeter between the oxygen sensor side terminal of the disconnected connector and the ground as shown in below figure.

#### NOTE:

- Be sure to use a voltmeter whose inner resistance is more than some  $M\Omega$  per IV or a digital type voltmeter. Any other voltmeter should not be used because accurate measurements are not obtained.
- NEVER apply voltage to the oxygen sensor as it may cause damage to the sensor.
- NEVER connect ohmmeter to the oxygen sensor as it may cause damage to the sensor.

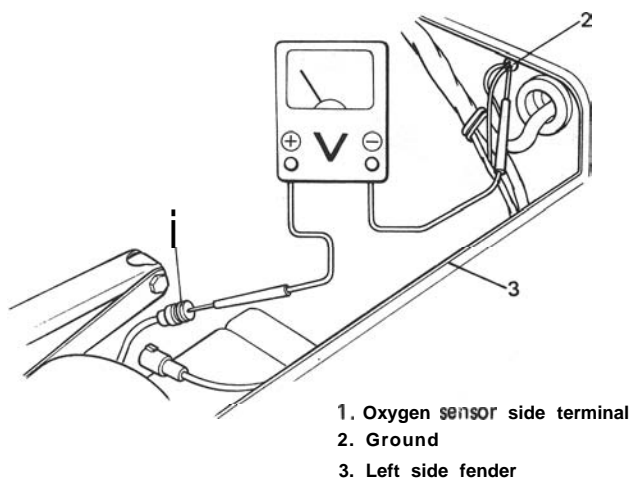
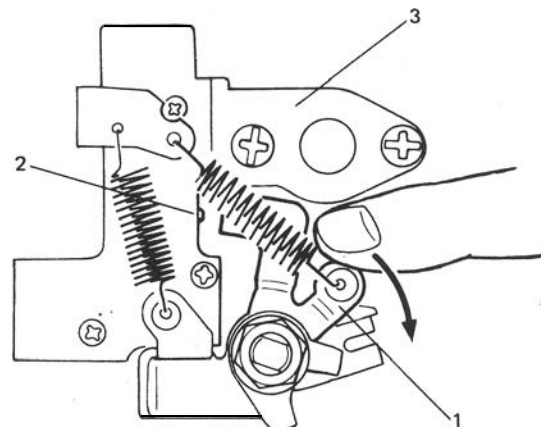


Fig. 5-3-35 Connecting voltmeter

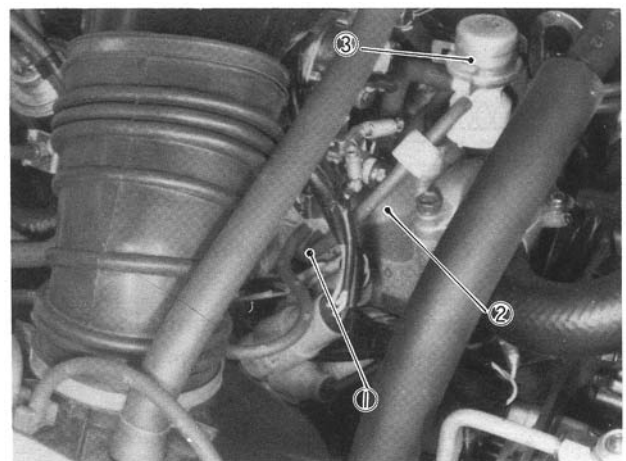
- 4) While keeping the engine running at 1,500 – 2,000 rpm, turn the wide open micro switch “OFF” by moving the lever with the finger as shown in below figure. Then take the reading of the voltmeter to make sure it is about 0.8V.



1. Lever
2. Wide open micro switch
3. Carburetor

Fig. 5-3-36 Moving lever

- 5) With the engine running at 1,000 – 1,500 rpm, disconnect the vacuum hose at the intake manifold as shown in below figure. At this time, check to ensure that the voltmeter indicator is below 0.2V.



1. Vacuum hose
2. Intake manifold
3. MCV

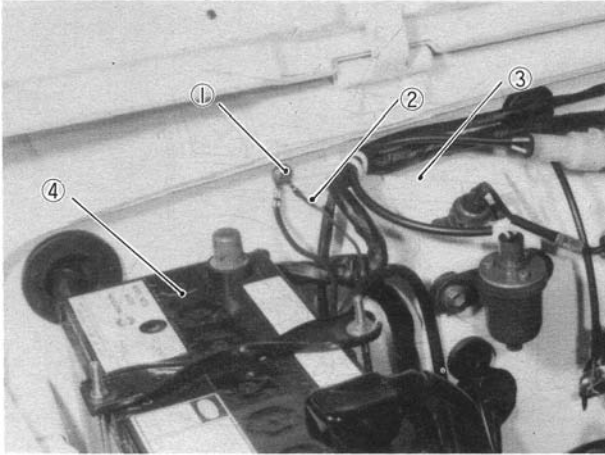
Fig. 5-3-37 Disconnecting vacuum hose

- 6) After checking, reconnect the vacuum hose to the intake manifold and the connector of oxygen sensor.



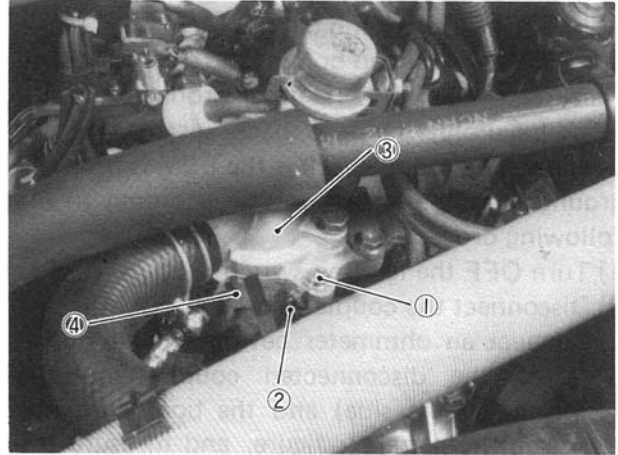
4) If the measured resistance between each terminal (① and ②) and the body is “ZERO (0)” ohm, the ECM is grounded securely at two points. If the resistance is not “ZERO (0)” ohm, the possibility is that the lead wire between the terminal (① or ②) and the ground is not securely grounded or disconnected.

The below figures show the particular points where “B” and “B/G” wires are grounded. Check for their secure grounding by referring to these figures.



- 1. Body ground
- 2. Black/Green lead wire
- 3. Dash panel
- 4. Battery

**Fig. 5-3-40 Body ground**



- 1. Engine ground
- 2. Black lead wire
- 3. Thermostat cap
- 4. Intake manifold

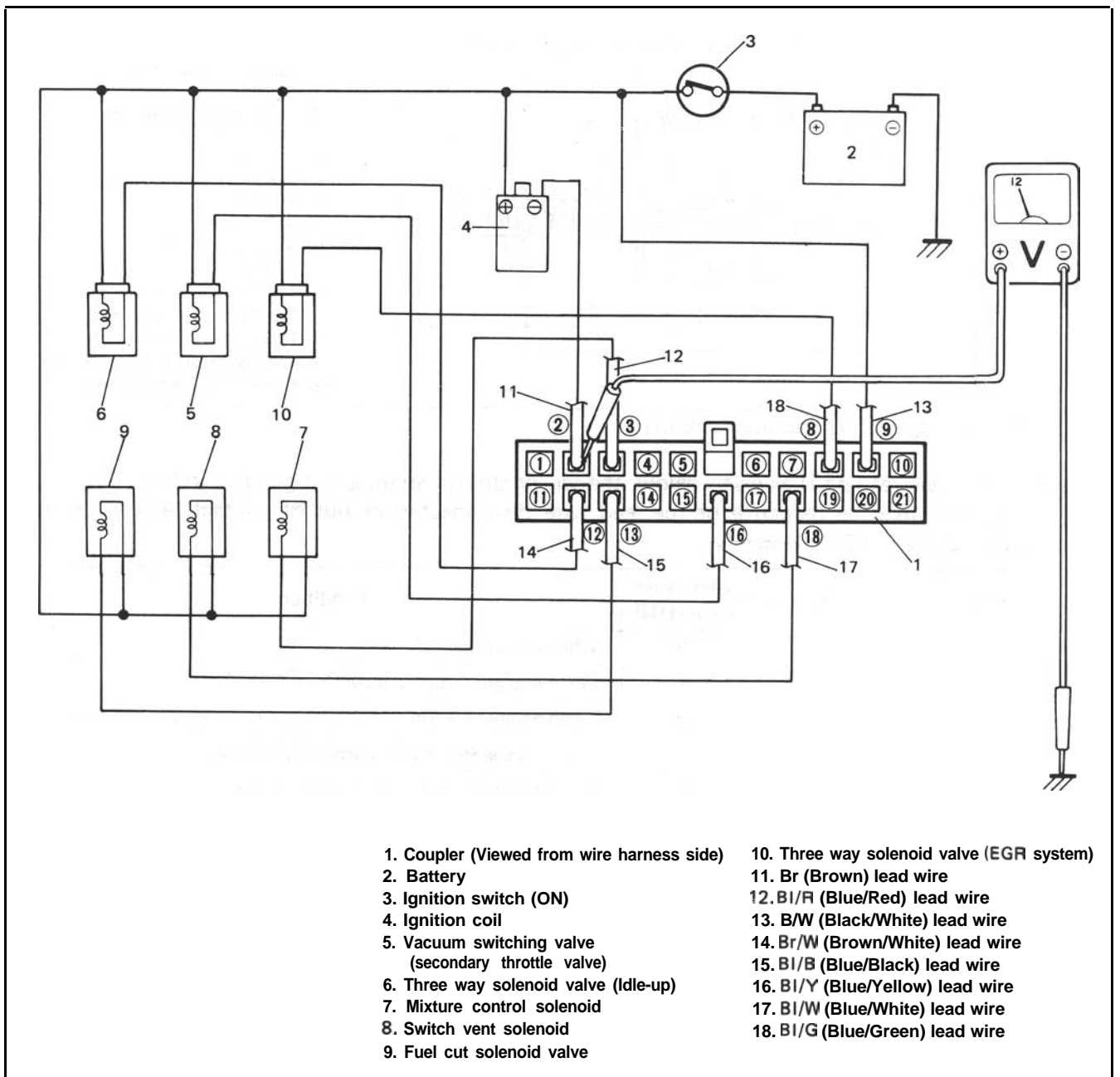
**Fig. 5-3-41 Engine ground**

5) After checking, connect the coupler to ECM securely.

**[Checking ECM power circuits]**

Connected to the ECM are the ignition coil and solenoids or solenoid valves. If a disconnection or a failure of contact occurs within a circuit (power circuit) including any of these coil or solenoids or solenoid valves, signals will not be sent to the ECM and as a result, the feed back system will not operate properly. Therefore, check the power circuits according to the following procedure.

- 1) Disconnect the coupler connected to the ECM.
- 2) Turn ON the ignition switch but be sure not to run the engine.
- 3) Connect a voltmeter between the terminal ② of the disconnected coupler (on the wiring harness side) and the body (ground) as shown in below figure and measure the voltage. And then repeat the same with each of the terminals ③, ⑧, ⑨, ⑫, ⑬, ⑯ and ⑱. If the measured voltage between each terminal and the body is about 12V, each circuit is in good condition.
- 4) If about 12V is not obtained in the above check, the particular circuit may be disconnected or out of contact. Check the circuit for such conditions.
- 5) After checking, connect the coupler to ECM securely.



**Fig. 5-3-42 Checking ECM power circuits**

[Checking sensors and their lead wires]

The sensors constituting the feed back system are; wide open micro switch, idle micro switch, thermal switch, high altitude compensator, thermal engine room switch and fifth switch. If any of the above sensors malfunctions or if the sensor circuit has some trouble, signals are not sent to the ECM and consequently the feed back system will not function properly.

Therefore, check each sensor and its circuit according to the following procedure.

- 1) Turn OFF the ignition switch.
- 2) Disconnect the coupler from the ECM.
- 3) Connect the ohmmeter between the terminal ④ of the disconnected coupler and the terminal ① (ground) as shown in below figure and measure the resistance. And then repeat the same with each of the terminals ⑤, ⑪, ⑭, ⑮ and ⑲.

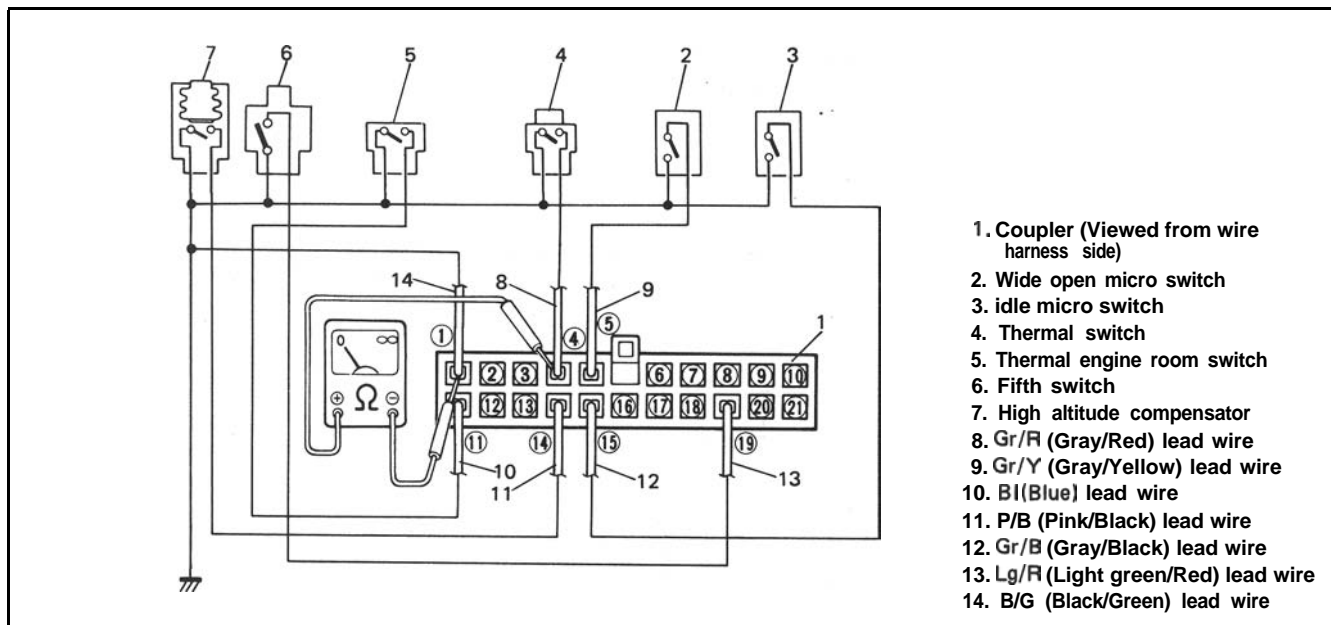


Fig. 5-3-43 Checking sensors and their circuits

- 4) If each ohmmeter reading is as given below, the sensor and its circuit are in good condition. But if not, the sensor itself may be defective or the lead wire disconnected or out of contact. After checking, connect the coupler to ECM securely.

Sensor	Terminal	Ohmmeter reading(Ω)	Condition
Thermal switch	④	0	When coolant temp. is low.
		∞	When coolant temp. is above 46.5°C (116°F).
Idle micro switch	⑮	0	When engine is warm and accelerator pedal is not depressed.
		∞	When accelerator pedal is depressed a little.
High altitude compensator	⑭	∞	When altitude is below 1,220 m (4,000 ft.).
		0	When altitude is above 1,220 m (4,000 ft.).
Thermal engine room switch	⑪	0	When temp. in engine room is low.
		∞	When temp. in engine room is above 19.5°C (67°F).
Wide open micro switch	⑤	0	When accelerator pedal is not depressed or depressed only a little.
		∞	When accelerator pedal is depressed all the way.
F i f t h s w i t c h	⑲	∞	When gear shift lever is shifted to low, second, third, fourth or reverse gear position.
		0	When gear shift lever is shifted to fifth gear position.

[Checking function of oxygen sensor and feed back system]

If oxygen sensor fails to send signal to the ECM, the feed back system does not operate. While the feed back system is at work, the ECM sends out the feed back signal, and in this condition, after warming up engine to normal operating temperature, when the cancel switch or check switch, is turned ON, the "CHECK ENGINE" light in the instrument cluster flashes. If the "CHECK ENGINE" light does not flash in such conditions as described above, check the feed back system for function according to the following procedure.

**NOTE:**

Except for Canadian specification vehicle, also when mileage sensor is turned ON (the odometer indicates 50,000, 80,000 or 100,000 miles), the "CHECK ENGINE" light flashes. If the "CHECK ENGINE" light does not flash in such condition, check the feed back system for function according to the following procedure.

- 1) Remove the ECM from the instrument main panel.
- 2) Connect the coupler to the ECM.  
(Don't disconnect the coupler from the ECM if connected)
- 3) Warm up the engine to the normal operating temperature and keep it at idle.
- 4) Connect voltmeter between the terminals ⑩ (oxygen sensor signal) and ⑪ (ground) as shown in below figure.
- 5) If the voltmeter indicator deflects between 0V and 0.8V while racing the engine at a speed between idling and 1,500 – 2,000 rpm, the feed back system is in good condition.

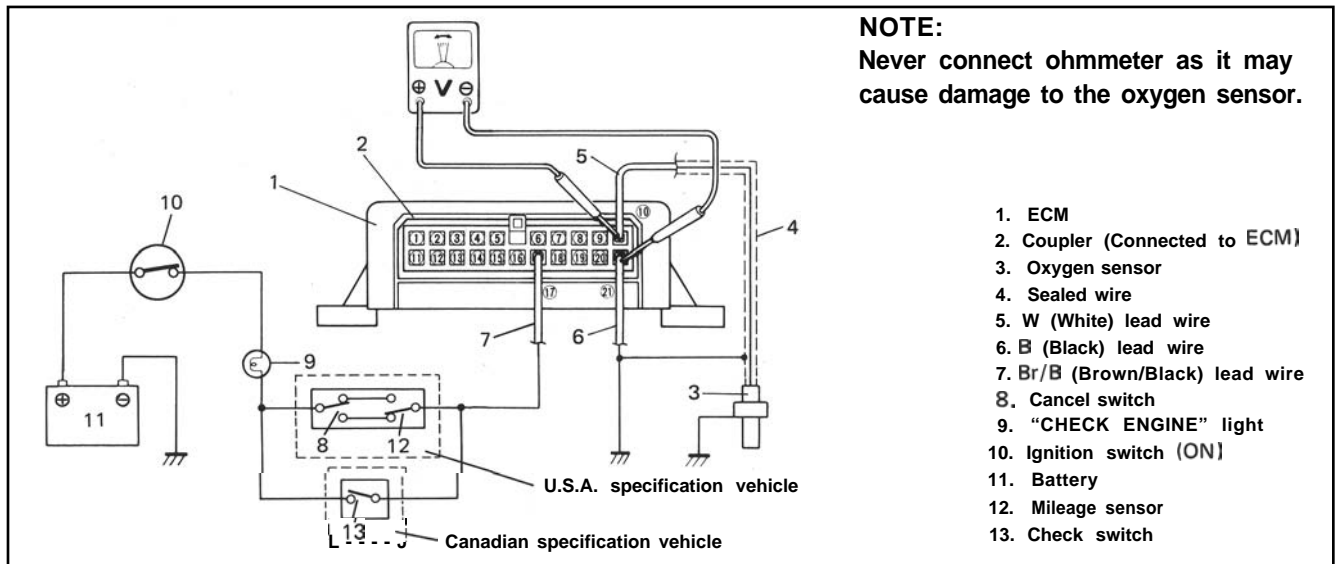


Fig., 5-3-44 Checking oxygen sensor signal

6) If the indicator does not deflect between 0V and 0.8V, possible causes are as follows.

Voltmeter indicator:	Possible causes
Remains at "Zero (0)"V	<ul style="list-style-type: none"> <li>● Oxygen sensor lead wire is disconnected or out of contact.</li> <li>● intake system is leaky or air/fuel mixture is too lean due to malfunction of carburetor,</li> <li>● Inner resistance of voltmeter is too small.</li> <li>● Oxygen sensor is defective.</li> </ul>
Indicates about 0.8V and does not deflect.	<ul style="list-style-type: none"> <li>● Choke is operating because engine is not warmed up fully.</li> <li>● Thermal switch is defective.</li> <li>● Wide open micro switch is defective.</li> <li>● Lead wire of mixture control solenoid is disconnected.</li> <li>● Mixture control solenoid valve is defective.</li> </ul>

7) After it is confirmed through steps 1) to 5) that oxygen sensor sends signals to ECM properly, check feed back signal according to the following procedure. If feed back system operates properly, ECM should send out feed back signal.

a) Connect an ohmmeter between terminal ⑰ and body (ground). Be sure to connect positive (+) prod of the ohmmeter to body (ground) and negative (-) prod to terminal ⑰ as shown in below figure and never connect the other way around.

**NOTE:**

**For this check, cancel switch must be OFF ("CHECK ENGINE" light off).**

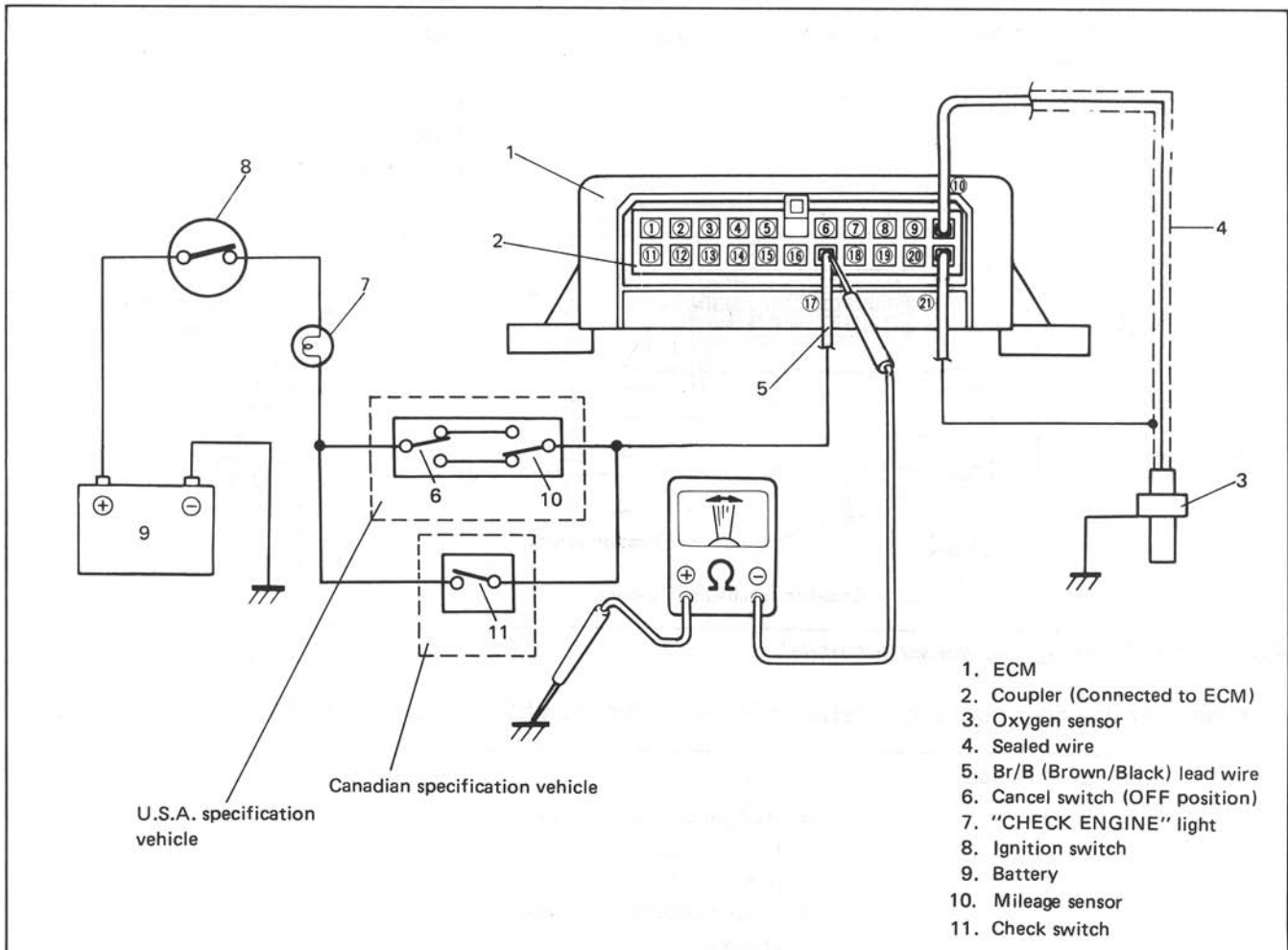
b) If indicator of ohmmeter deflects when connected as described in the above step, it means that ECM sends out feed back signal, that is, feed back system operates properly.

**NOTE:**

**If indicator doesn't deflect at all, reverse connection (positive prod to terminal ⑰ and negative prod to body) and check.**

In this state, turning ON cancel or check switch causes "CHECK ENGINE" light to flash. If "CHECK ENGINE" light does not flash, wire harness, bulb of light or cancel/check switch may be defective.

8) After checking, install ECM to instrument main panel, and make sure coupler is connected to ECM securely.



**Fig. 5-3-45 Checking feed back signal**



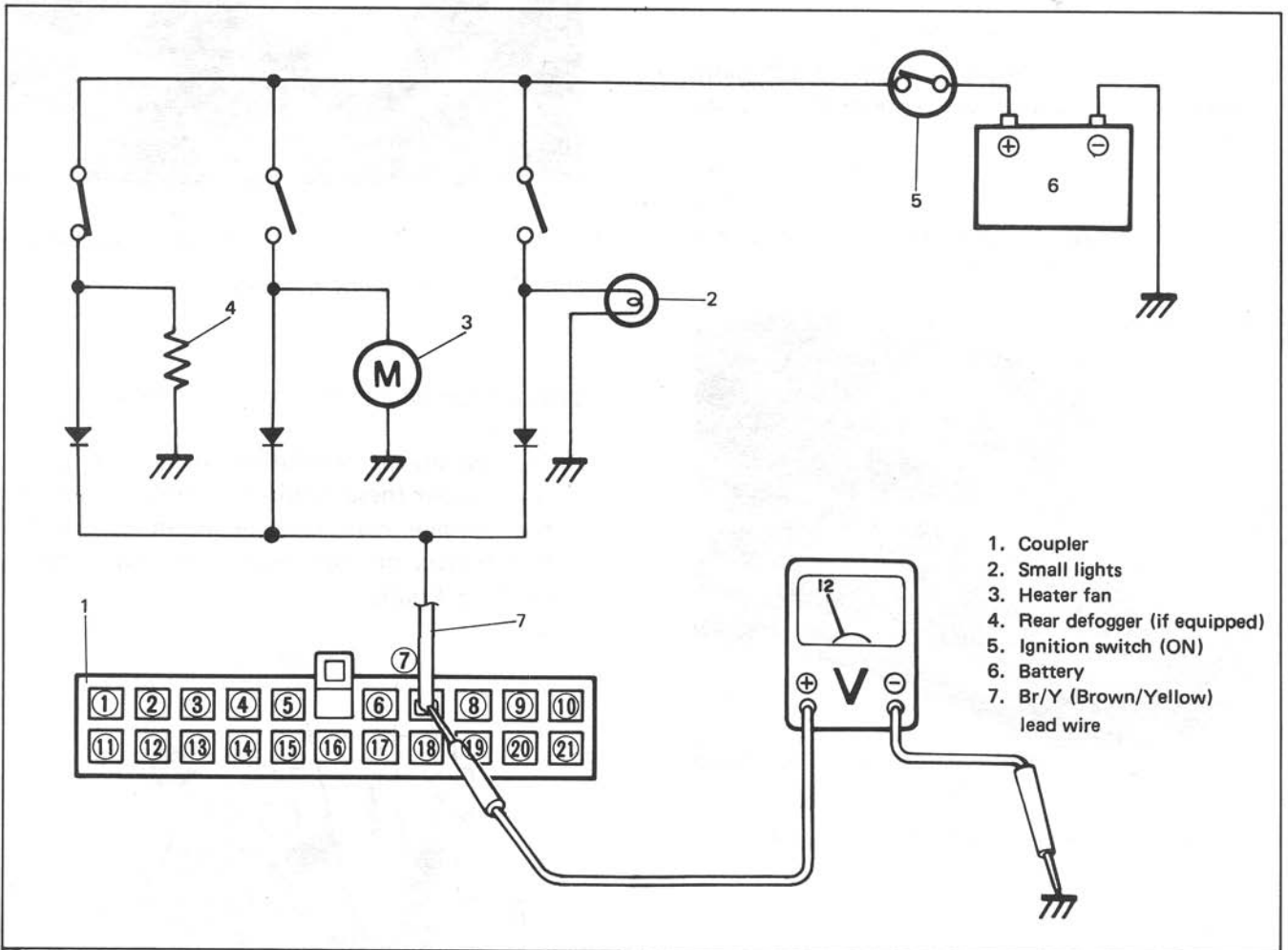
**[Checking idle-up signal]**

The idle-up system operates when any of the small lights (such as tail light, side marker light and license light), heater fan and rear defogger is put in operation. If the idle-up actuator fails to operate even when any of such equipments is put in operation, check if signal is sent to the ECM according to the following procedure.

- 1) Disconnect the coupler from the ECM.
- 2) Turn ON the ignition switch but don't run the engine.
- 3) Connect a voltmeter between the ⑦ terminal and the body (ground) as shown in below figure. If the voltmeter indicates 11 – 14V when each equipment is operated individually, it means that idle-up signal is sent to the ECM.

If the voltmeter does not indicate 11 – 14V, the particular circuit is disconnected or in poor contact. Check the circuit for such conditions.

- 4) After checking, connect the coupler to ECM securely.



**Fig. 5-3-46 Checking idle-up signal**

### [Replacing ECM]

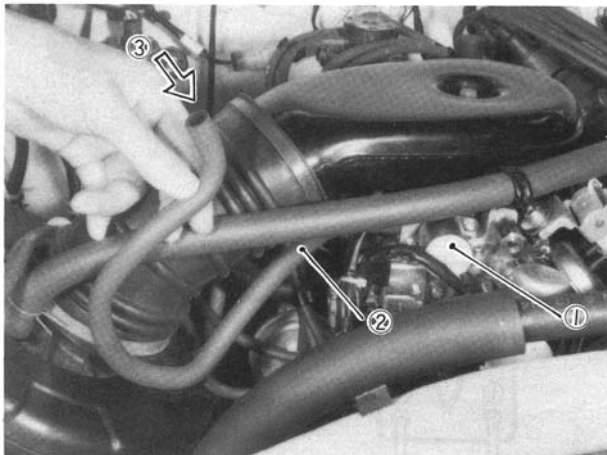
If a malfunction such as those listed below still occurs even after confirming proper function and condition of the sensors of the feedback system and their circuits through the above checks, a trouble may exist within the ECM. In such a case, replace the ECM.

- Fuel consumption increases even in normal driving.
- Engine tends to stall.
- Engine is hard to start.

### SWITCH VENT SOLENOID

#### Checking switch vent solenoid

- 1) Disconnect canister hose from switch vent solenoid and connect a new hose to the pipe of solenoid.
- 2) Blow air into new hose with ignition switch at both "OFF" and "ON" (but without starting engine) and check to be sure that air passes through solenoid in both cases.



1. Switch vent solenoid      3. Blow air  
2. Canister hose (new)

**Fig. 5-3-47 Checking switch vent solenoid**

#### **WARNING:**

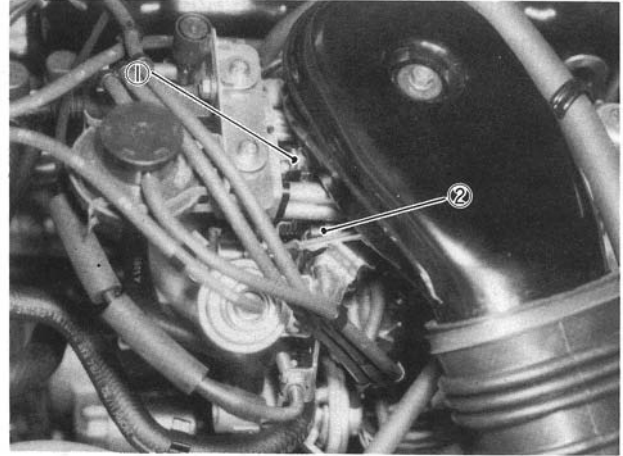
**Do not suck the hose. The fuel vapor in float chamber is harmful.**

- 3) Start engine and run it at idle speed. Then check to be sure that air does not pass through solenoid when blowing air into new hose.
- 4) Remove new hose and connect original hose to switch vent solenoid.

### FUEL CUT SYSTEM

#### Checking fuel cut system

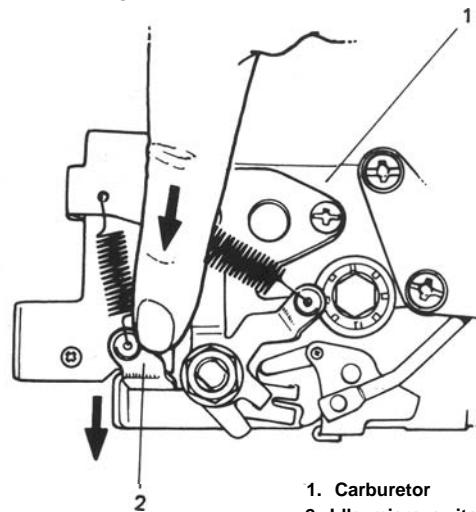
- 1) Make sure that fuel cut solenoid valve makes a clicking sound when ignition switch is turned to "ON" or "OFF" without cranking engine.



1. Carburetor  
2. Fuel cut solenoid valve

**Fig. 5-3-48 Fuel cut solenoid valve**

- 2) Warm up engine to normal operating temperature.
- 3) Increase engine revolution to 3,000 – 3,500 rpm. Under these conditions, check to be sure that engine rpm changes when idle micro switch lever on carburetor is moved as shown in below figure.



1. Carburetor  
2. Idle micro switch lever

**Fig. 5-3-49 Idle micro switch lever**

If found defective in above checks 1) and 3), check fuel cut solenoid circuit referring to item "checking feedback system circuits" in p. 5-29.

## EXHAUST GAS RECIRCULATION (EGR) SYSTEM

### Checking EGR system

#### NOTE:

- Before checking, confirm that altitude is not higher than 1,220 m (4,000 ft) (atmospheric pressure is below 680mmHg) and gear shift lever is at neutral position.
- When performing this check at higher than 1,220 m (4,000 ft) altitude, be sure to disconnect HAC coupler.

1) Run engine when it is cool (coolant temperature is below 55°C (131°F)) and check that EGR valve diaphragm is not operating in this state, by touching diaphragm with finger.

#### WARNING:

If EGR valve is hot, it may be necessary to wear gloves to avoid burning finger.

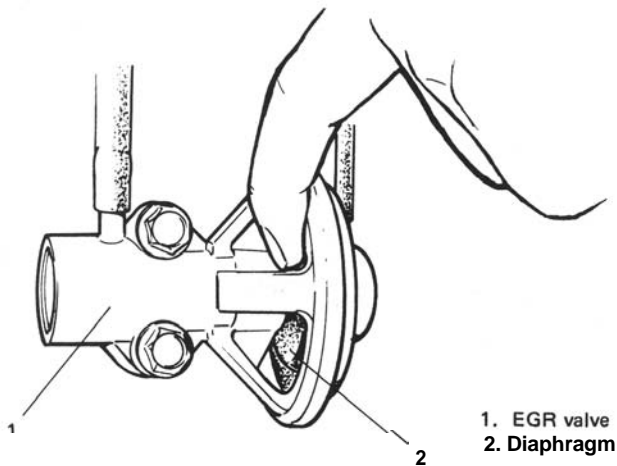


Fig. 5-3-50 Checking EGR valve diaphragm

2) Warm up engine to normal operating temperature and race it after warming up. Then check to be sure that diaphragm moves toward ① in below figure during acceleration and toward ② during deceleration.

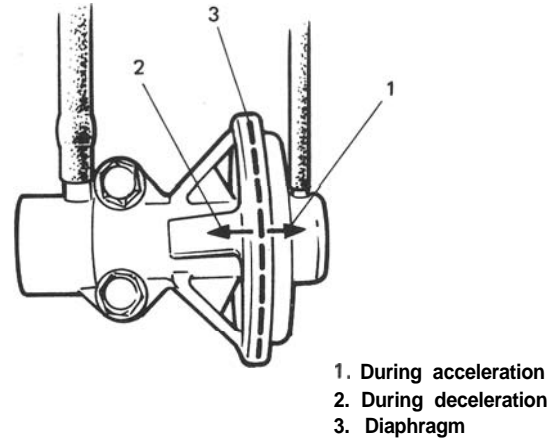


Fig. 5-3-51 Movement of EGR valve diaphragm

If found defective in above step 1) or 2), inspect following parts according to each procedure.

#### NOTE:

Refer to item "CHECKING SENSOR AND THEIR LEAD WIRES" in page 5-32 for checking HAC, fifth switch and their circuit.

[Vacuum hoses]

Check hoses for connection, leakage, clog and deterioration. Replace as necessary.

[EGR valve]

- 1) Disconnect vacuum hose from TWSV.
- 2) Connect vacuum pump gauge to its hose.
- 3) Check that EGR valve diaphragm moves smoothly and that it is held at the same position when more than 20 cmHg vacuum is applied to EGR valve.

If diaphragm doesn't move smoothly, or it isn't held at the same position, replace EGR valve.

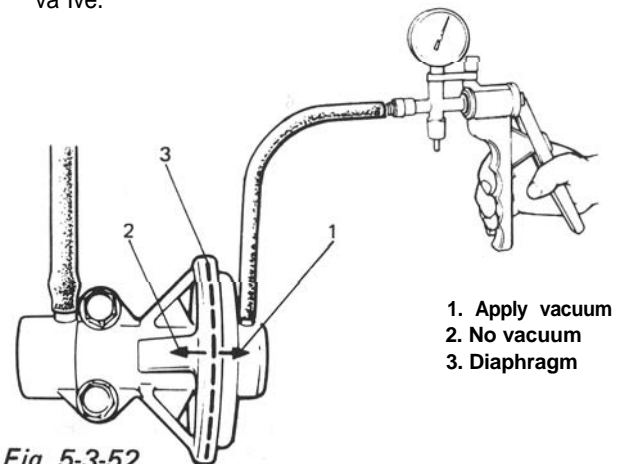


Fig. 5-3-52

4) After checking, be sure to connect vacuum hose to TWSV.

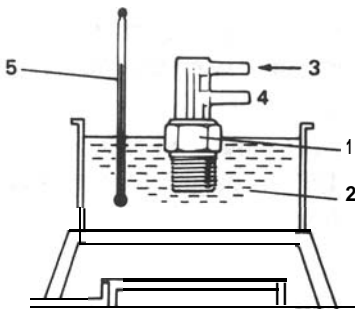
[Bi-metal vacuum switching valve (BVSV)]

**NOTE:**

For the rough check of the operation, BVSV can be checked by warming up or cooling down the engine without being removed from the intake manifold.

The check procedure is the same as the following except item 1), 2) and 5).

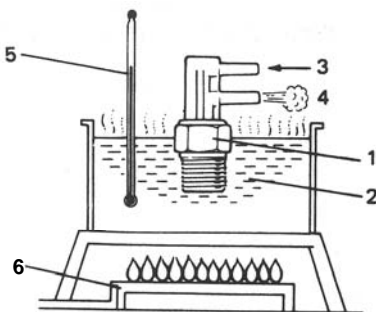
- 1) Drain cooling system when engine is cold.
- 2) Disconnect vacuum hoses and remove BVSV from intake manifold.
- 3) While keeping BVSV cool (below 53°C (127° F)), blow nozzle "3". Air should not come out of nozzle "4".



1. BVSV
2. Cool water
3. Blow air (nozzle)
4. "No air" (nozzle)
5. Thermometer

*Fig. 5-3-53 Checking B VSV (1)*

- 4) While keeping BVSV warm (above 65° C (149°F)) in hot water, blow nozzle "3". Air should come out of nozzle "4".



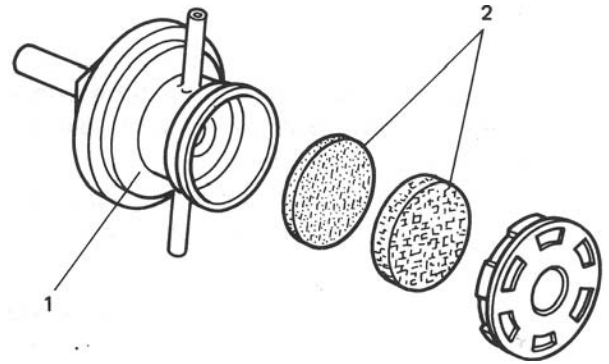
1. BVSV
2. Hot water
3. Blow air (nozzle)
4. Air (nozzle)
5. Thermometer
6. Heater

*Fig. 5-3-54 Checking B VSV (2)*

- 5) Reinstall BVSV to intake manifold. Before installing, wind sealing tape on its thread.
- 6) Connect vacuum hoses.

[EG R modulator]

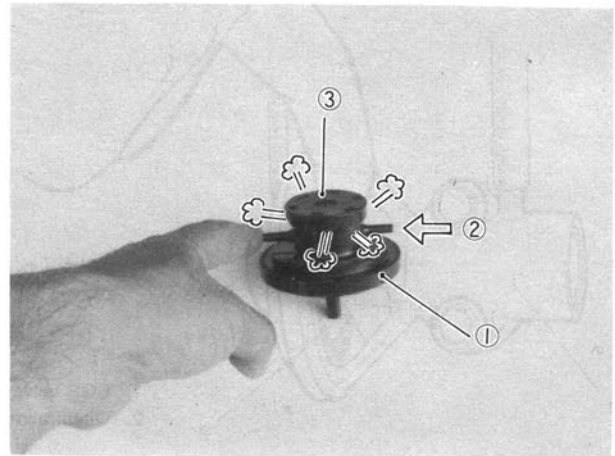
- 1) Check filter for contamination and damage. Using compressed air, clean filter.



1. EGR modulator
2. Filter

*Fig. 5-3-55 Filter of EGR modulator*

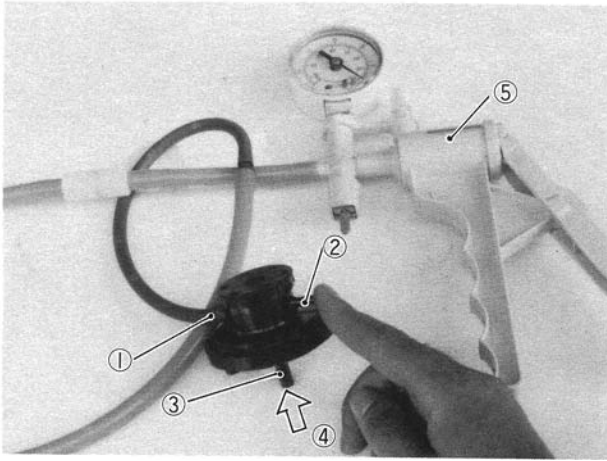
- 2) Remove EGR modulator and plug nozzle with your finger. Blow air into another nozzle and check that air passes through to air filter side freely.



1. EGR modulator
2. Blow air
3. Air filter

*Fig. 5-3-56 Checking EGR modulator (1)*

- 3) Connect vacuum pump gauge to nozzle ① and plug nozzle ② with your finger. While blowing air into nozzle ③, operate vacuum pump gauge and check that vacuum is applied to modulator then.



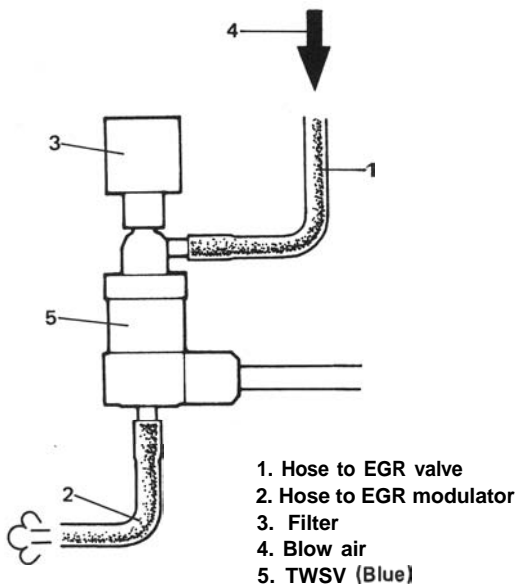
- |           |                      |
|-----------|----------------------|
| 1. Nozzle | 4. Blow air          |
| 2. Nozzle | 5. Vacuum pump gauge |
| 3. Nozzle |                      |

**Fig. 5-3-57 Checking EG R modulator (2)**

- 4) After checking, install modulator and connect hoses securely. Refer to Fig. 5-I-I for connecting.

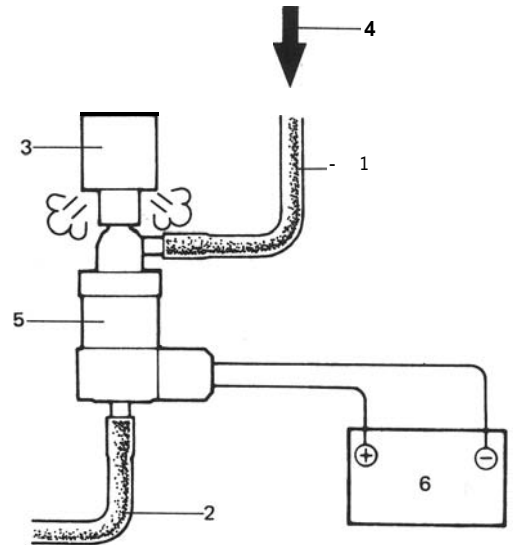
[Three way solenoid valve (TWSV)]

- 1) Disconnect 2 vacuum hoses from EGR modulator and EGR valve.
- 2) Blow hose ①. Air should come out of hose ② and not out of filter.



**Fig. 5-3-58**

- 3) Disconnect coupler and connect 12V-battery to TWSV terminals. In this state, blow hose ①. Air should come out of filter and not out of hose ②.



- |                          |             |
|--------------------------|-------------|
| 1. Hose to EGR valve     | 4. Blow air |
| 2. Hose to EGR modulator | 5. Twsv     |
| 3. Filter                | 6. Battery  |

**Fig. 5-3-59**

- 4) After checking, be sure to connect vacuum hoses and coupler.

**SECTION 6**

**ENGINE COOLING SYSTEM**

**CONTENTS**

<b>6-1. GENERAL DESCRIPTION .....</b>	<b>6-2</b>
<b>6-2. REMOVAL .....</b>	<b>6-5</b>
<b>6.3. INSPECTION OF COMPONENTS .....</b>	<b>6-7</b>
<b>THERMOSTAT .....</b>	<b>6-7</b>
<b>RADIATOR .....</b>	<b>6-8</b>
<b>WATER PUMP .....</b>	<b>6-8</b>
<b>6-4. IMPORTANT STEPS FOR REINSTALLATION .....</b>	<b>6-9</b>
<b>WATER PUMP .....</b>	<b>6-9</b>
<b>THERMOSTAT .....</b>	<b>6-9</b>
<b>COOLING FAN AND WATER PUMP BELT .....</b>	<b>6-9</b>
<b>RADIATOR .....</b>	<b>6-10</b>
<b>6-5. MAINTENANCE SERVICE .....</b>	<b>6-10</b>
<b>WATER PUMP BELT .....</b>	<b>6-10</b>
<b>COOLANT .....</b>	<b>6-11</b>
<b>COOLANT LEVEL .....</b>	<b>6-11</b>
<b>COOLING SYSTEM SERVICE .....</b>	<b>6-12</b>
<b>COOLING SYSTEM, FLUSH AND REFILL .....</b>	<b>6-12</b>

## 6-1. GENERAL DESCRIPTION

The cooling system consists of the radiator cap, radiator, water reservoir tank, hoses, water pump, cooling fan & clutch, thermostat. The radiator is of tube-and-fin type.

### Cooling System Circulation

During engine warm-up (thermostat closed), the water pump discharges coolant into the water jacket chamber adjacent to No. 1 cylinder. Coolant then flows through the cylinder block and the cylinder head. Coolant then returns to the water pump through intake manifold, heater inlet hose, heater unit, heater outlet hose, and water intake pipe.

During normal temperatures (thermostat open), coolant takes the same basic route but is now allowed to flow past the thermostat, the inlet hose and the radiator, and then back to the water pump through the outlet hose and the water intake pipe.

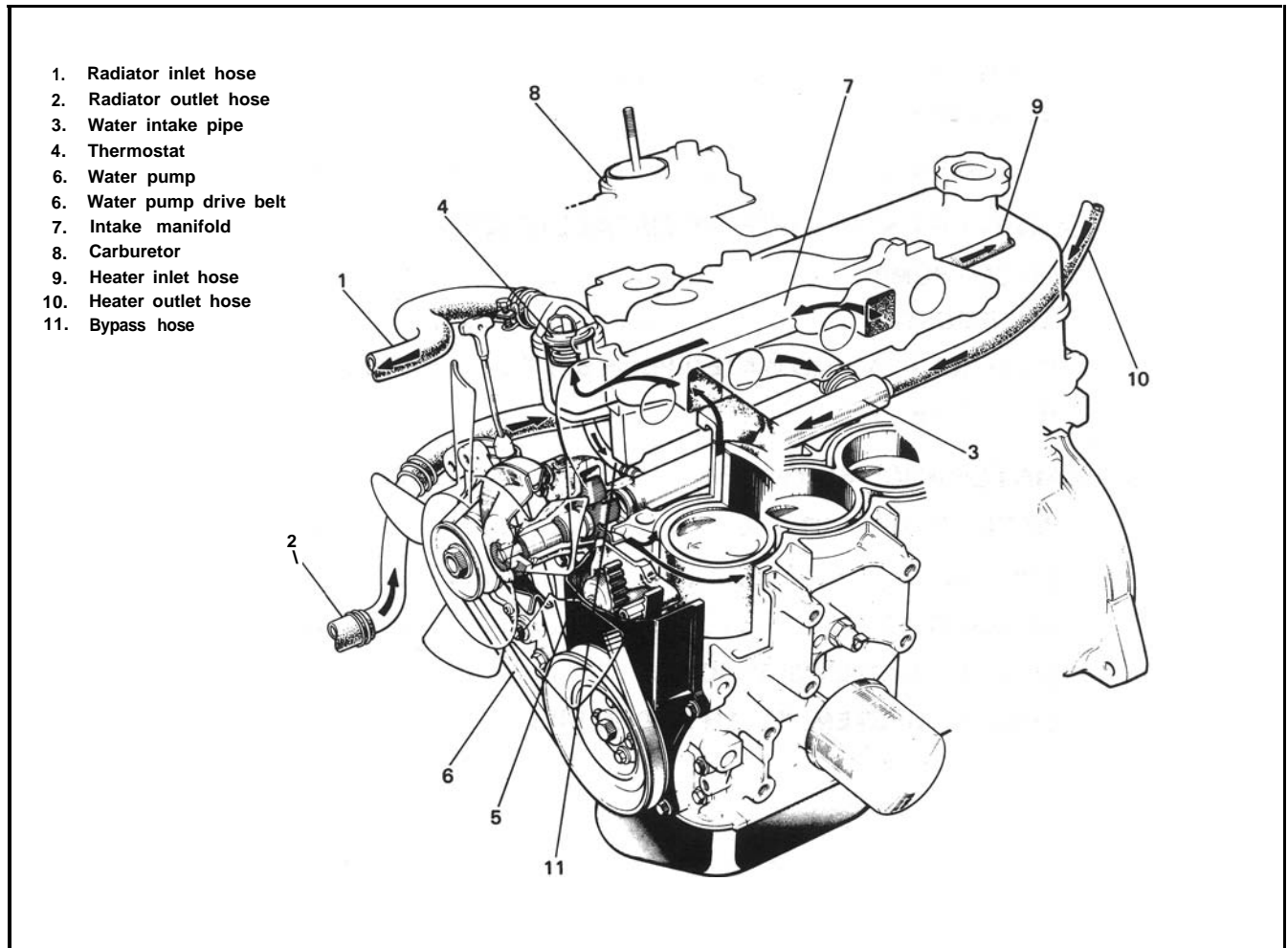


Fig. 6-1 Cooling system

## Radiator Cap

A pressure-vent cap is used on the radiator. The cap contains a pressure valve and vacuum valve. The pressure valve is held against its seat by a spring of pre-determined strength which protects the cooling system by relieving the pressure if the pressure in cooling system rises by 0.9 kg/cm<sup>2</sup> (12.8 psi, 90 kPa). The vacuum valve is held against its seat by a light spring which permits opening of the valve to relieve vacuum created in the system when it cools off and which otherwise might cause the radiator to collapse.

The cap has its face marked 0.9, which means that its pressure valve opens at 0.9 kg/cm<sup>2</sup> (12.8 psi, 90 kPa).

### NOTE:

**Do not remove radiator cap to check engine coolant level; check coolant visually the see-through water reservoir tank.**

**Coolant should be added only to reservoir tank as necessary.**

### WARNING:

As long as there is pressure in the cooling system, the temperature can be considerably higher than the boiling temperature of the solution in the radiator without causing the solution to boil. Removal of the radiator cap while engine is hot and pressure is high will cause the solution to boil instantaneously and possibly with explosive force, spewing the solution over engine, fenders and person removing cap. If the solution contains flammable anti-freeze such as alcohol (not recommended for use at any time), there is also the possibility of causing a serious fire.

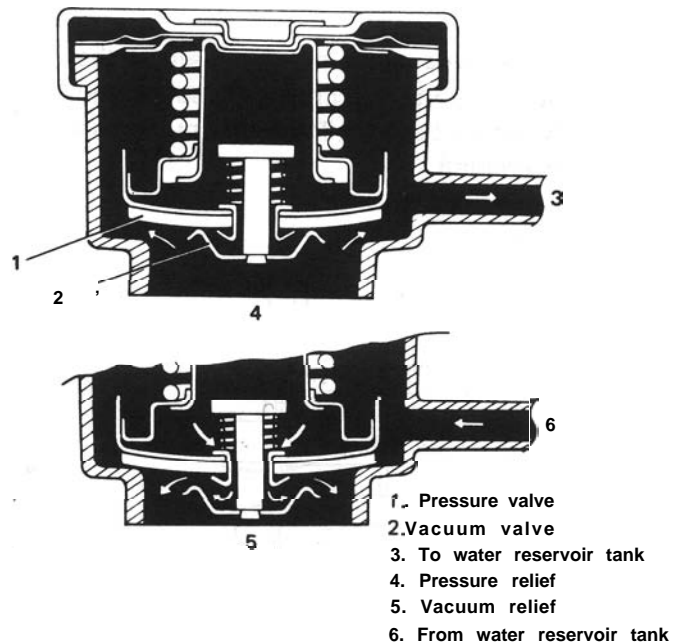


Fig. 6-2

## Water Reservoir Tank

A "see-through" plastic reservoir tank is connected to the radiator by a hose. As the car is driven, the coolant is heated and expands. The portion of the coolant displaced by this expansion flows from the radiator into the reservoir tank.

When the car is stopped and the coolant cools and contracts, the displaced coolant is drawn back into the radiator by vacuum.

Thus, the radiator is kept filled with coolant to the desired level at all times, resulting in increased cooling efficiency.

Coolant level should be between "FULL" and "LOW" marks on the reservoir tank.

Coolant should be added only to the reservoir tank as necessary.

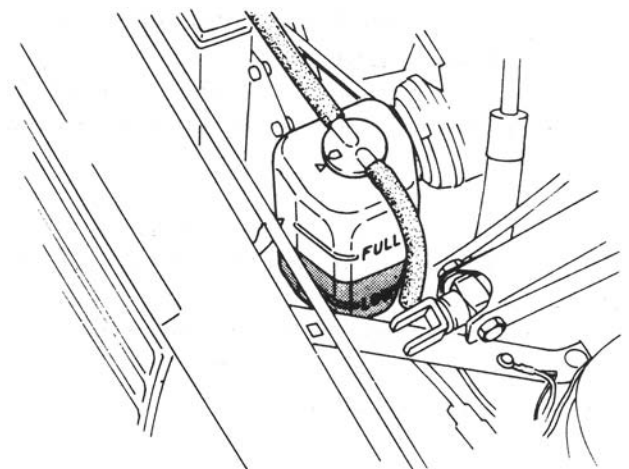


Fig. 6-3 Water reservoir tank



### Water Pump

The centrifugal type water pump is used in the cooling system. The pump impeller is supported by a totally sealed bearing. The water pump can not be disassembled.

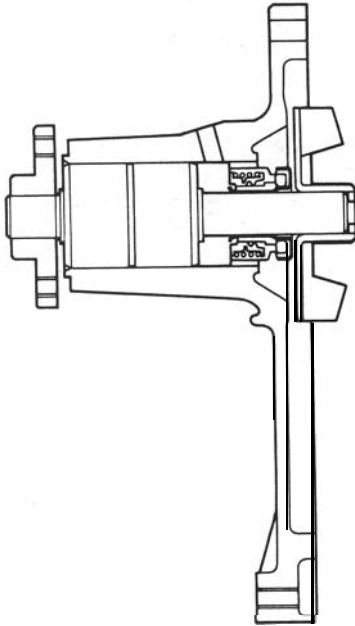


Fig. 6-4

### Thermostat

A wax pellet type thermostat is used in the coolant outlet passage to control the flow of engine coolant, to provide fast engine warm up and to regulate coolant temperatures.

A wax pellet element is hermetically contained in a metal case, and expands when heated and contracts when cooled.

When the pellet is heated and expands, the metal case pushes down the valve to open it.

As the pellet is cooled, the contraction allows a spring to close the valve.

Thus, the valve remains closed while the coolant is cold, preventing circulation of coolant through the radiator.

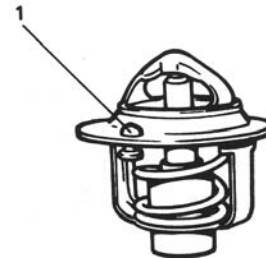
At this point, coolant is allowed to circulate only throughout the engine to warm it quickly and evenly.

As the engine warms, the pellet expands and the thermostat valve opens, permitting coolant to flow through the radiator.

In the top portion of the thermostat, an air bleed valve is provided; this valve is for venting out the gas or air, if any, that is accumulated in the circuit.

There are two types of thermostat, A and B, as given below. Either one is used depending on vehicle specifications. The temperature at which the valve begins to open is stamped on each thermostat. Be sure to note this stamped temperature for replacement.

Thermostat functional spec. $\pm 1.5^{\circ}\text{C}$ ( $2.7^{\circ}\text{F}$ )		
	Thermostat "A" (Thermostat "B")	
Temp. at which valve begins to open	82°C (179°F)	88°C (190°F)
Temp. at which valve become fully open	95°C (203°F)	100°C (212°F)
Valve lift	More than 8 mm at 95°C	More than 8 mm at 100°C



1. Air bleed valve

Fig. 6-5 Thermostat

## 6-2. REMOVAL

### WARNING:

- Check to make sure that cooling water temperature is cold before removing any part of cooling system components.
- Also be sure to disconnect ⊖ cord from battery ⊖ terminal before removing any part.

### 1. Coolant Draining

- 1) Remove radiator cap.
- 2) Loosen drain plug ① on radiator to empty its water side.

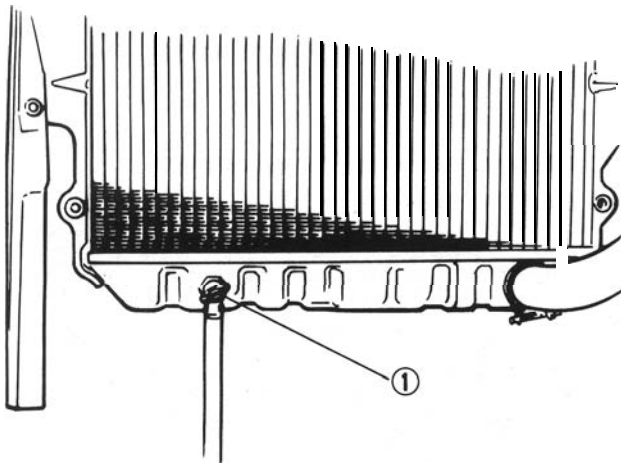


Fig. 6-6

### 2. Cooling Water Pipes or Hoses

- 1) Drain cooling system.
- 2) To remove these pipes or hoses, loosen screw on each pipe or hose clip and pull hose end off.

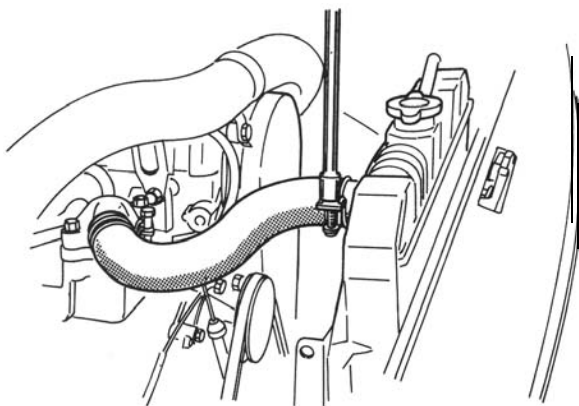


Fig. 6-7

### 3. Water Pump Drive Belt

- 1) Loosen water pump drive belt tension.
- 2) Remove belt.

### 4. Cooling Fan, Fan Clutch and Water Pump Pulley

- 1) Remove radiator shroud securing bolts (4 pcs) and cooling fan securing nuts (or bolts, 4 pcs).

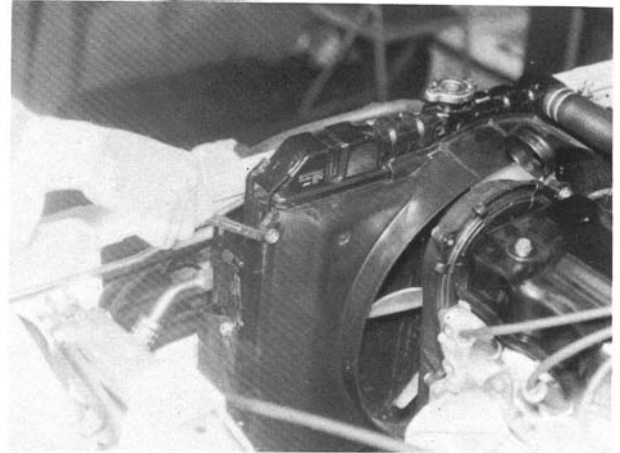


Fig. 6-8

- 2) Then remove radiator shroud and cooling fan and/or fan clutch and water pump pulley at the same time.

### 5. Radiator

- 1) Drain cooling system.
- 2) Loosen water pump drive belt tension.
- 3) Remove radiator shroud and cooling fan & clutch at the same time.
- 4) Disconnect water hoses from radiator.
- 5) Remove radiator.



Fig. 6-9

## 6. Thermostat

- 1) Drain cooling system.
- 2) Disconnect thermostat cap from intake manifold.

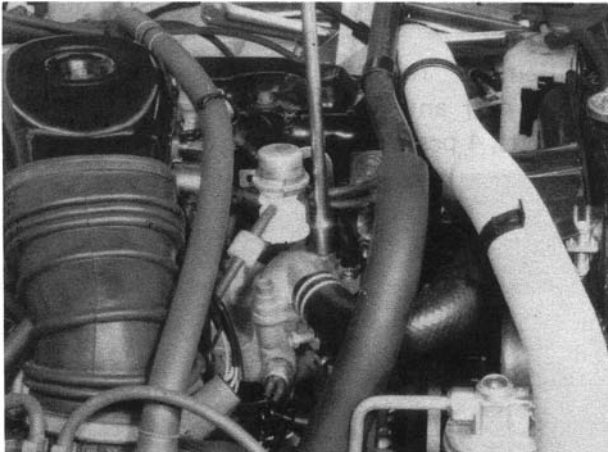


Fig. 6-10

- 3) Remove thermostat.

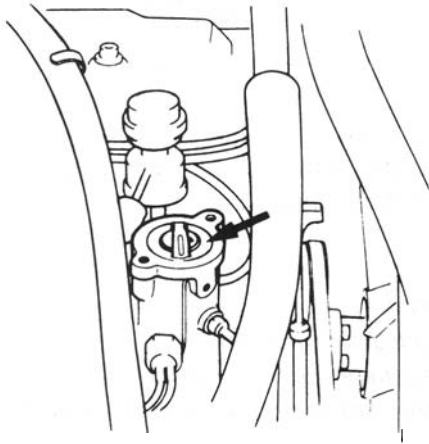


Fig. 6-11

## 7. Water Pump

- 1) Drain cooling system.  
Refer to 1. Coolant draining on previous page.
- 2) Remove the radiator shroud and cooling fan & clutch at the same time.  
Refer to item 4 on previous page.
- 3) Loosen water pump drive belt tension.  
Then remove water pump pulley and pump drive belt.
- 4) Remove crankshaft pulley by removing 4 pulley bolts. Crankshaft timing belt pulley bolt at the center is needs not to be loosened.

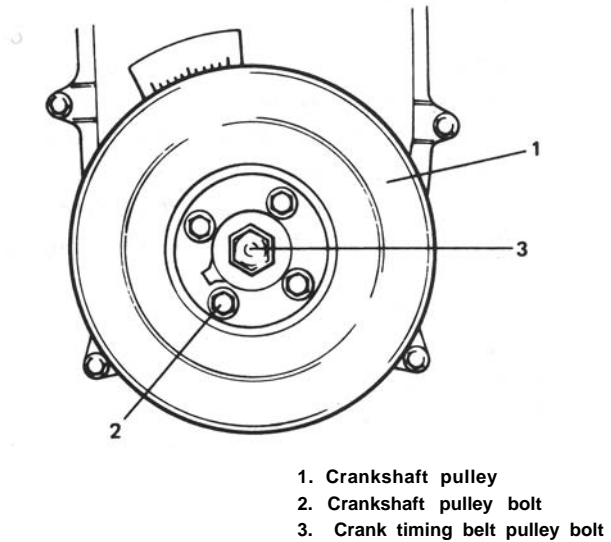


Fig. 6-12

- 5) Remove timing belt outside cover.

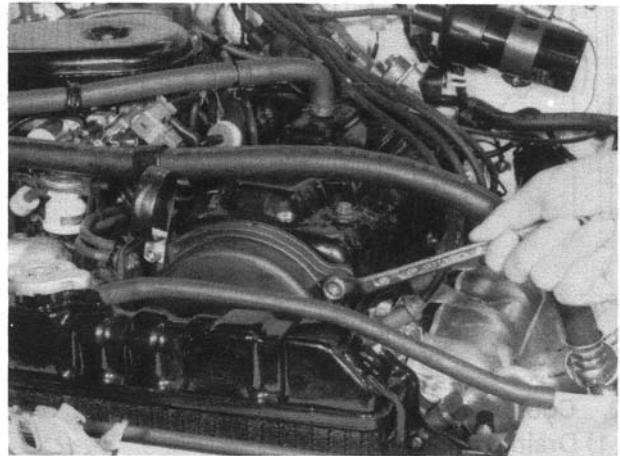


Fig. 6-13

- 6) Loosen tensioner bolt and stud, and remove belt from crank timing belt pulley and camshaft pulley after pushing up tensioner plate fully with finger as shown in Figure.

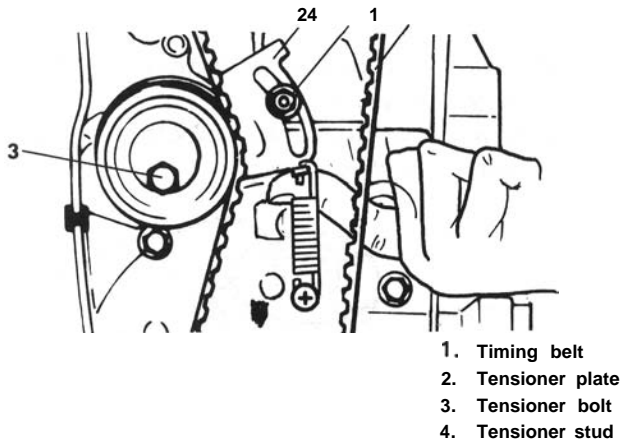


Fig. 6- 14

- 7) Remove timing belt tensioner, plate and spring.
- 8) Remove water pump assembly.

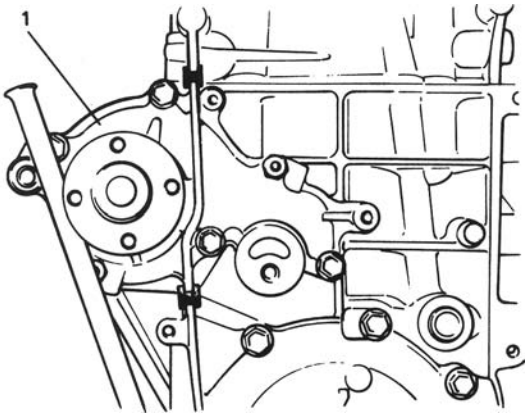


Fig. 6- 15

### 6-3. INSPECTION OF COMPONENTS

#### Thermostat

- 1) Make sure that air bleed valve of thermostat is clear. Should this valve be clogged, engine would tend to overheat.

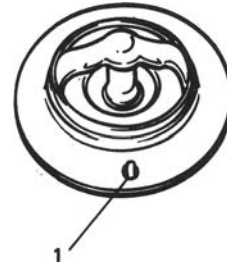


Fig. 6- 16

- 2) Check valve seat for some foreign matters being stuck which prevent valve from seating tight.
- 3) Check thermostatic movement of wax pellet as follows:

- Immerse thermostat in water, and heat water gradually.
- Check that valve starts to open at specification temp.
- If valve starts to open at a temperature substantially below or above, thermostat unit should be replaced with a new one. Such a unit, if reused, will bring about overcooling or overheating tendency.

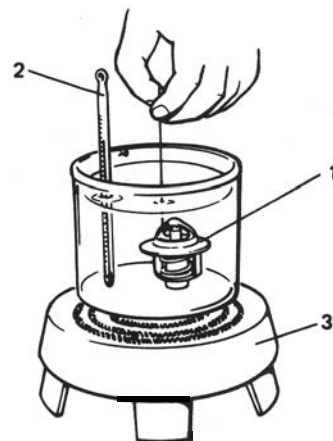


Fig. 6-17

### Radiator

If the water side of the radiator is found excessively rusted or covered with scales, clean it by flushing with the radiator cleaner compound. This flushing should be carried out at regular intervals for scale or rust formation advances with time even where a recommended type of coolant is used. Periodical flushing will prove more economical.

Inspect the radiator cores and straighten the flattened or bent fins, if any. Clean the cores, removing road grimes and trashes.

Excessive rust or scale formation on the wet side of the radiator lowers the cooling efficiency. Flattened or bent fins obstruct the flow of air through the core to impede heat dissipation.

Radiator flushing interval	Two years (recommended)
----------------------------	-------------------------



Fig. 6-18

### Water Temperature Gauge

For gauge inspection, refer to SECTION 21 BODY ELECTRICAL EQUIPMENT of this manual.

### Water Pump

#### NOTE:

Do not disassemble water pump.

If any repair is required on pump, replace it as assembly.

- Rotate water pump by hand to check for smooth operation.  
If pump does not rotate smoothly or makes an abnormal noise, replace it.

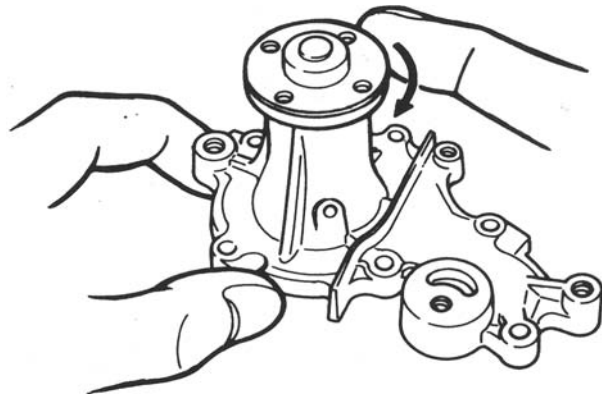


Fig. 6-19

## 6-4. IMPORTANT STEPS FOR REINSTALLATION

### Water Pump

- 1) Install new pump gasket to cylinder block.
- 2) Install water pump to cylinder block.

Tightening torque for bolts & nuts	10 – 13 N·m
	1.0 – 1.3 kg-m
	7.5 – 9.0 lb-ft

After installing water pump, install rubber seal between water pump and oil pump, and another between water pump and cylinder head.

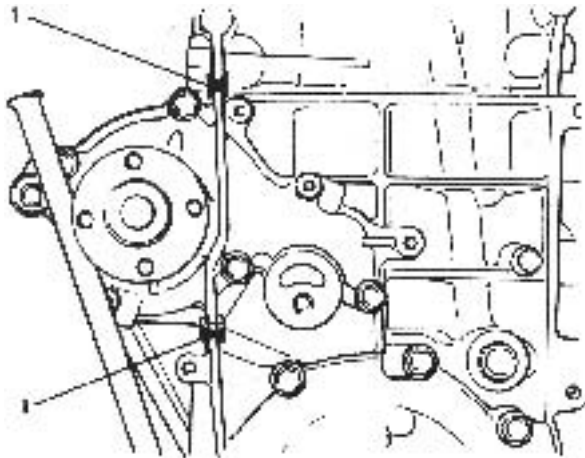


Fig. 6-20

1. Rubber seal

- 3) Install belt tensioner plate, tensioner, tensioner spring, timing belt and timing belt outside cover.

### NOTE:

- Special care must be used when installing belt tensioner and timing belt. Be sure to refer to p. 3-48 of this manual.
  - Torque each bolt and nut to specification.
- 4) Install crankshaft pulley, water pump pulley, pump drive belt, cooling fan & clutch and radiator shroud.
  - 5) Adjust intake and exhaust valve lashes.  
(For adjustment and related data, refer to p. 3-53 of this manual).
  - 6) Adjust water pump belt tension.  
(Refer to P. 6-10).
  - 7) Connect negative cable at battery.
  - 8) Fill the cooling system.

### Thermostat

- 1) When positioning the thermostat on the intake manifold, be sure to bring its air breather valve ① to front side of the engine.

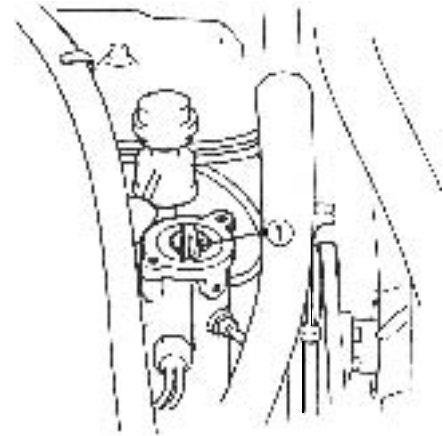


Fig. 6-21

- 2) Install new gasket and thermostat cap to intake manifold.
- 3) Fill the cooling system.

### Cooling Fan, Fan clutch and Water Pump Belt

Once cooling fan, fan clutch or water pump belt has been removed, make sure to tighten bolts and nuts securely in reinstallation and adjust pump belt tension to specification. (For specified tension, refer to p. 6-10.)

## Radiator

- 1) Tighten bolts securely for proper installation. Also, fix joints of 2 hoses with clamps.

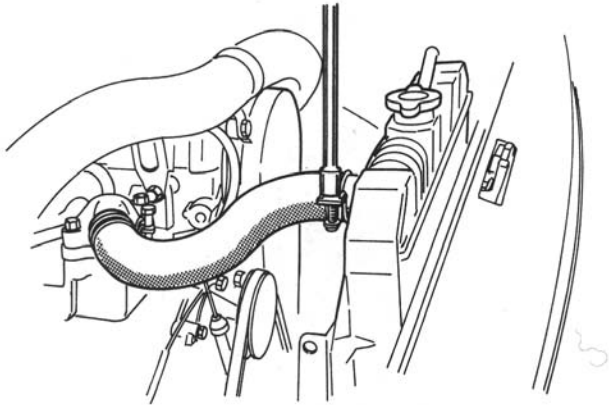


Fig. 6-22

- 2) Install radiator shroud and cooling fan & clutch at the same time.
- 3) Tighten shroud bolts and fan clutch nuts.
- 4) Adjust water pump belt tension.
- 5) Fill specified amount of coolant.

## 6-5. MAINTENANCE SERVICE

### Water Pump Belt

- 1) Inspect belt for cracks, cuts, deformation, wear and cleanliness. If it is necessary to replace belt, refer to p6-5 for procedure.
- 2) Check belt for tension. Belt is in proper tension when it deflects 6 to 9 mm (0.24 – 0.35 in.) under thumb pressure (about 10 kg or 22 lb.).

Belt tension specification	6 – 9 mm (0.24 – 0.35 in.) as deflection
----------------------------	--

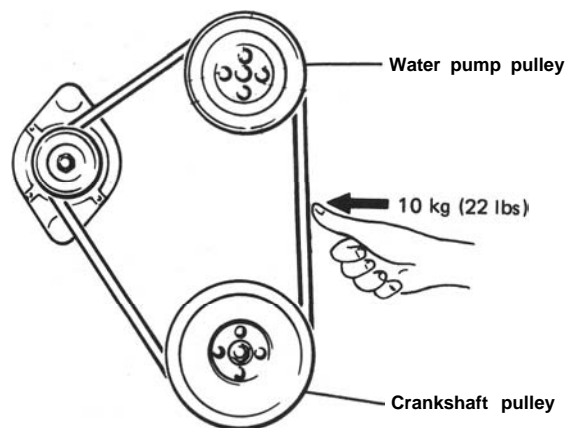


Fig. 623

- 3) If belt is too tight or too loose, adjust it to proper tension by displacing alternator position.

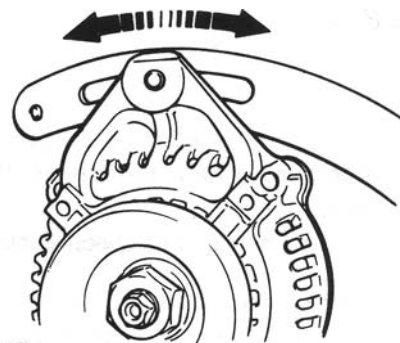


Fig. 6-24

- 4) Tighten alternator adjusting bolt and pivot bolt.

### WARNING:

All adjustments described above are to be performed with ENGINE NOT RUNNING.

## Coolant

The coolant recovery system is standard. The coolant in the radiator expands with heat, and the overflow is collected in the reservoir tank.

When the system cools down, the coolant is drawn back into the radiator.

The cooling system has been filled at the factory with a quality coolant that is either 50/50 mixture of water and GOLDEN CRUISER 1200 or 30/70 mixture of water and GOLDEN CRUISER 1200.

The 50/50 mixture coolant solution provides freezing protection to  $-36^{\circ}\text{C}$  ( $-33^{\circ}\text{F}$ ), the 30/70 mixture coolant solution provides freezing protection to  $-16^{\circ}\text{C}$  ( $3^{\circ}\text{F}$ ).

**GOLDEN CRUISER 1200 – “Anti-freeze and Summer Coolant” – its effects**

- 1) Its freezing temperature is much lower and depends on the concentration of GOLDEN CRUISER 1200. It is an anti-freeze coolant.
- 2) It does not corrode the metal surfaces of the cooling circuit. It is an anti-corrosion coolant.
- 3) It does not develop foam or bubbles. It is a foam-inhibited coolant.

When changing the engine coolant, use mixture of 50% water and 50% GOLDEN CRUISER 1200 for the market where ambient temperature falls lower than  $-16^{\circ}\text{C}$  ( $3^{\circ}\text{F}$ ) in winter and mixture of 70% water and 30% GOLDEN CRUISER 1200 for the market where ambient temperature doesn't fall lower than  $-16^{\circ}\text{C}$  ( $3^{\circ}\text{F}$ ).

**ANTI-FREEZE PROPORTIONING CHART**

Freezing Temperature	$^{\circ}\text{C}$	- 16	- 36
	$^{\circ}\text{F}$	3	- 33
GOLDEN CRUISER Concentration	%	30	50
Ratio of compound to cooling water	ltr.	1.44/3.36	2.40/2.40
	us pt.	3.04/7.10	5.07/5.07
	Imp. pt.	2.53/5.91	4.22/4.22

COOLANT CAPACITY	
Engine, radiator and heater	4.2 liters (8.9/7.4 US/Imp pt.)
Reservoir tank	0.6 liters (1.3/1.1US/Imp pt.)
Total	4.8 liters (10.1/8.4 US/Imp pt.)

### NOTE:

- Alcohol or methanol base coolants or plain water alone should not be used in cooling system at any time, as damage to cooling system could occur.
- Even in a market where no freezing temperature is anticipated, mixture of 70% water and 30% GOLDEN CRUISER 1200 should be used for the purpose of corrosion protection and lubrication.

### Coolant Level

To check level, lift hood and look at “see through” water reservoir tank.

It is not necessary to remove radiator cap to check coolant level.

### WARNING:

To help avoid danger of being burned:

- do not remove reservoir tank cap while coolant is “boiling”, and
- do not remove radiator cap while engine and radiator are still hot

Scalding fluid and steam can be blown out under pressure if either cap is taken off too soon.

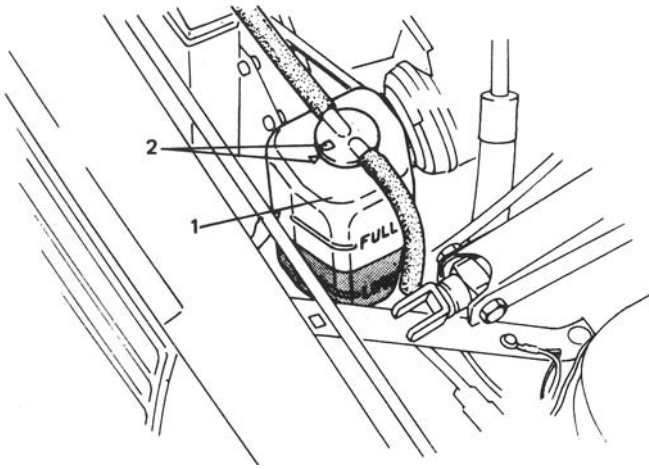
When engine is cool, check coolant level in reservoir tank. A normal coolant level should be between “FULL” and “LOW” marks on reservoir tank.

If coolant level is below “LOW” mark, remove reservoir tank cap and add proper coolant to tank to bring coolant level up to “FULL” mark. Then, reinstall cap aligning the arrow marks on the tank and cap.

### NOTE:

If proper quality antifreeze is used, there is no need to add extra inhibitors or additives that claim to improve system. They may be harmful to proper operation of system, and are unnecessary expense.





1. Reservoir tank  
2. Arrow mark

Fig. 6-25

### Cooling System Service

Cooling system should be serviced as follows.

- 1) Check cooling system for leaks or damage.
- 2) Wash radiator cap and filler neck with clean water by removing radiator cap when engine is cold.
- 3) Check coolant for proper level and freeze protection.
- 4) Using a pressure tester, check system and radiator cap for proper pressure holding capacity 0.9 kg/cm<sup>2</sup> (12.8 psi, 90 kPa). If replacement of cap is required, use proper cap specified for this vehicle.
- 5) Tighten hose clamps and inspect all hoses. Replace hoses whenever cracked, swollen or otherwise deteriorated.
- 6) Clean frontal area of radiator core.

### NOTE:

After installing radiator cap ① to radiator, make sure that its ear ② is aligned with reservoir tank hose ③ as shown in Figure. If not, turn cap more to align its ear with hose.

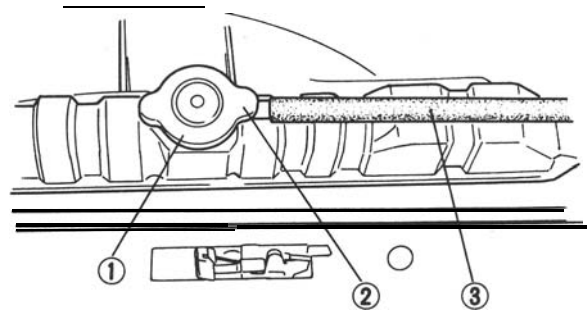


Fig. 6-26 Installation of radiator cap

### Cooling System, Flush and Refill

- 1) Remove radiator cap when engine is cool:

#### WARNING:

To help avoid danger of being burned, do not remove radiator cap while engine and radiator are still hot. Scalding fluid and steam can be blown out under pressure if cap is taken off too soon.

- 2) With radiator cap removed, run engine until upper radiator hose is hot (this shows that thermostat is open and coolant is flowing through system).
- 3) Stop engine and open radiator drain plug ① to drain coolant.

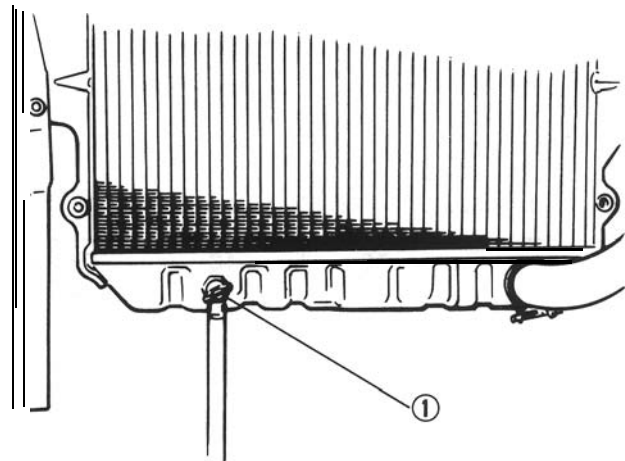


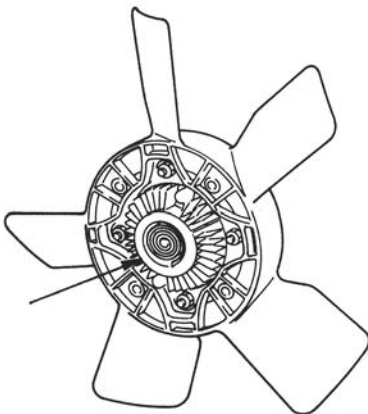
Fig. 6-27 Radiator drain plug

- 4) Close drain plug. Add water until system is filled and run engine until upper radiator hose is hot again.
- 5) Repeat steps 3) and 4) several times until drained liquid is nearly colorless.
- 6) Drain system and then close radiator drain plug tightly.
- 7) Disconnect hose from water reservoir tank. Remove tank and pour out any fluid. Scrub and clean inside of tank with soap and water. Flush it well with clean water and drain. Reinstall tank and hose.
- 8) Add proper mixture coolant (refer to page 6-11 of **GOLDEN CRUISER 1200** and water to radiator and tank.  
Fill radiator to the base of radiator filler neck and reservoir tank to "FULL" level mark. Reinstall reservoir tank cap, aligning the arrow marks on the tank and cap.
- 9) Run engine, with radiator cap removed, until radiator upper hose is hot.
- 10) With engine idling, add coolant to radiator until level reaches the bottom of filler neck. Install radiator cap, making sure that the ear of cap lines up with reservoir tank hose.

#### **Cooling Fan Clutch**

Inspect fluid coupling for oil leakage.

If necessary, replace fan clutch assembly. Do not disassemble clutch assembly.



**Fig. 6-28**

**SECTION 7**  
**CAR HEATER**

**CONTENTS**

**7-1. DESCRIPTION .....7-2**

**7-2. ELECTRICAL CIRCUIT..... 7-3**

**7-3. HEATER SERVICES .....7-4**

**7-4. REMOVAL AND INSTALLATION.....7-5**



## 7-1. DESCRIPTION

The car heater is of a hot water type and operates quietly. The air is heated by the engine coolant and the warm air is blown into the car interior by the blower motor.

The blower motor is driven electrically, independent of engine speed, and operates effectively even when the engine speed is low.

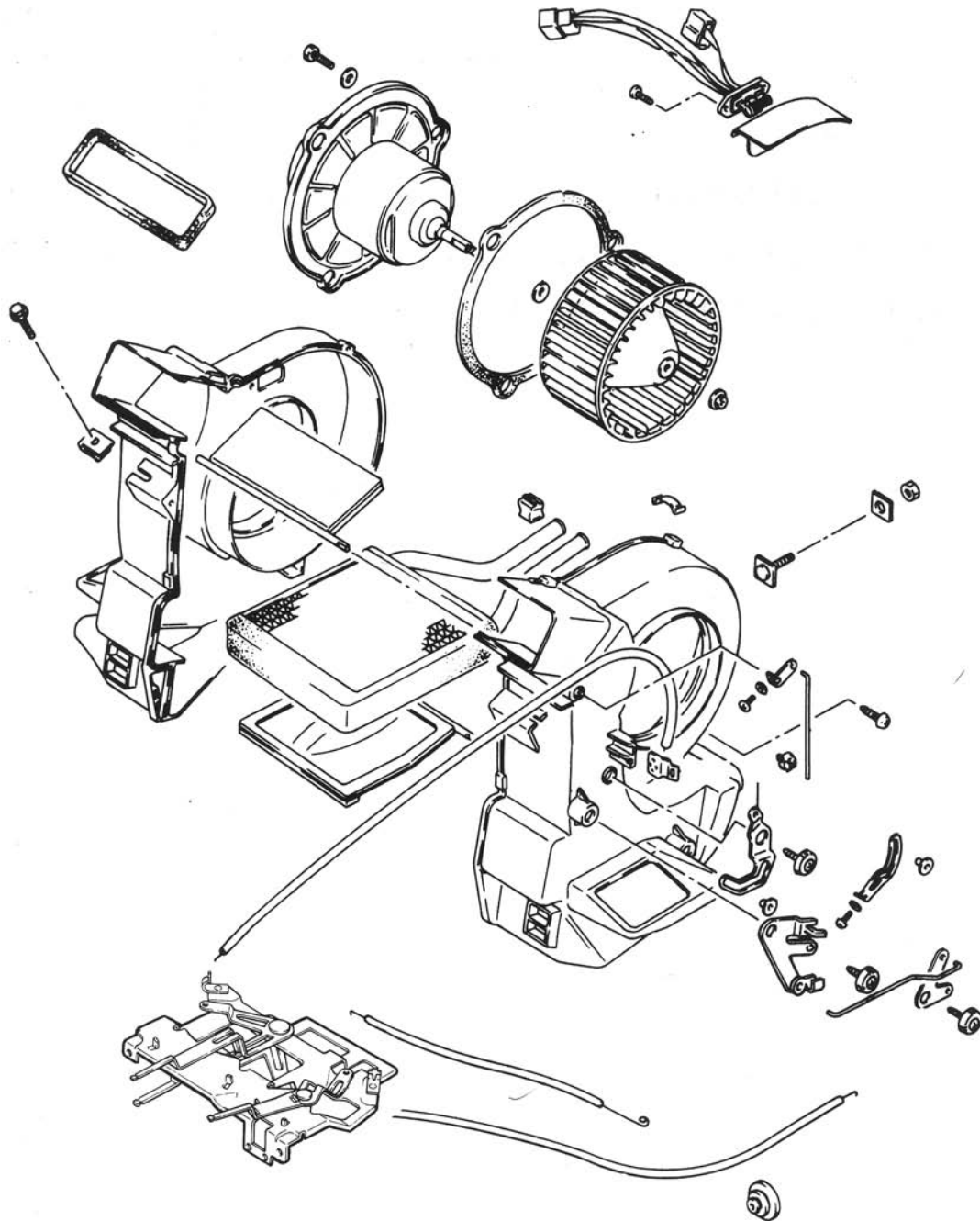


Fig. 7-1

## 7-2. ELECTRICAL CIRCUIT

The circuit diagram (Fig. 7-2) shows how the blower motor is controlled. Turn the main switch to "ON", turn (slide) the blower switch lever on one step, and voltage is applied across the blower motor. The current is small because of the resistor provided in the circuit (indicated as "blower motor resistance" in the diagram).

Under this condition, the blower runs slowly. By turning (sliding) the blower switch lever fully, the full battery voltage is applied across the blower motor, a large current flows and the blower motor runs at full speed.

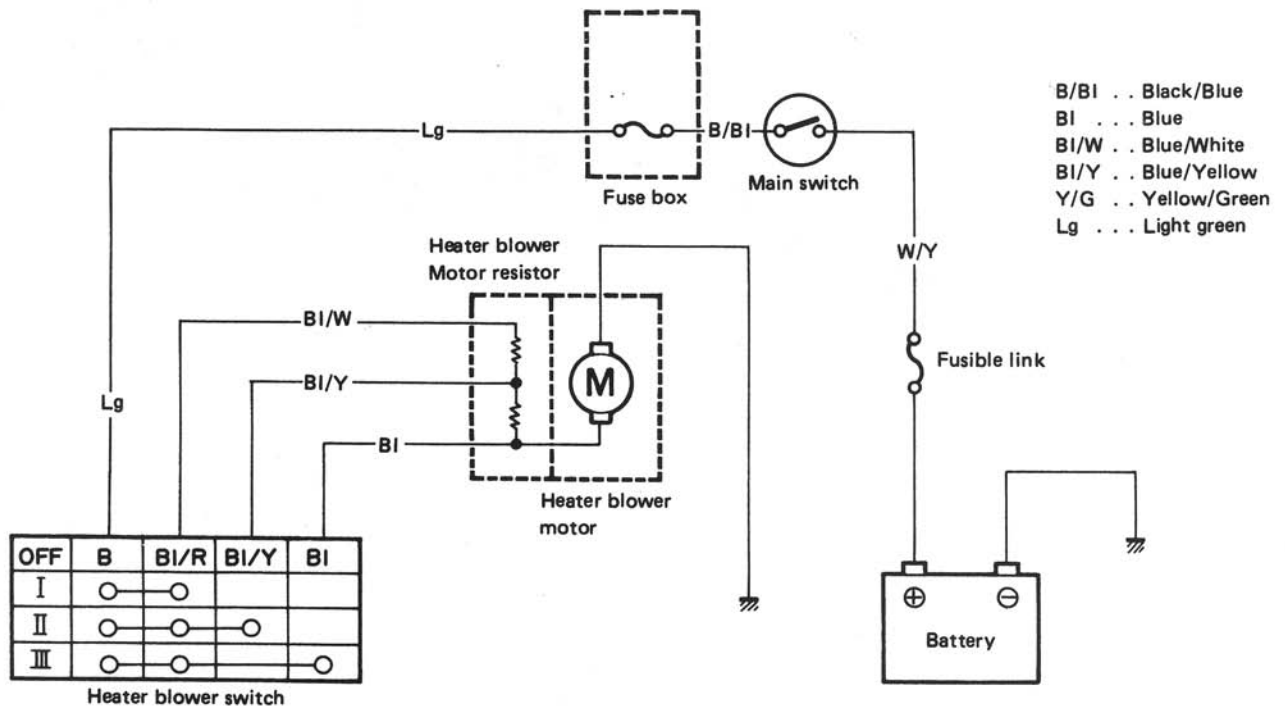


Fig. 7-2

### 7-3. HEATER SERVICES

#### Blower resistor

This resistor is on heater case. Check it for signs of cracking or breakage and replace as necessary. If blower motor will not run or when resistor is replaced, check continuity between Blue/White and Blue/Black terminals using a circuit tester.

Blower resistor specification	Several ohms
-------------------------------	--------------

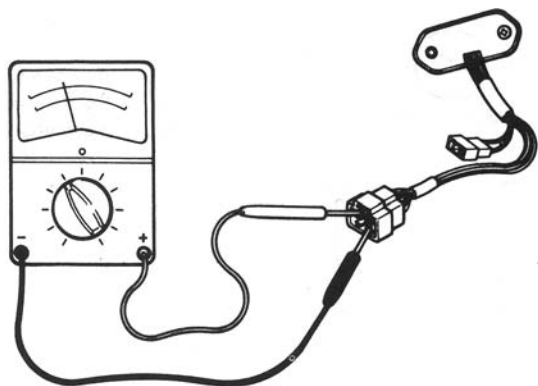


Fig. 7-3

#### Blower switch

Using a circuit tester, check this switch for circuit continuity:

III	○	—	—	○
II	○	—	○	
I	○	○		
OFF				
	Black	Blue/red	Blue/Yellow	Blue

#### Heater hoses

Check heater hoses for the connection condition, breakage, cracks and other damage and replace if necessary.

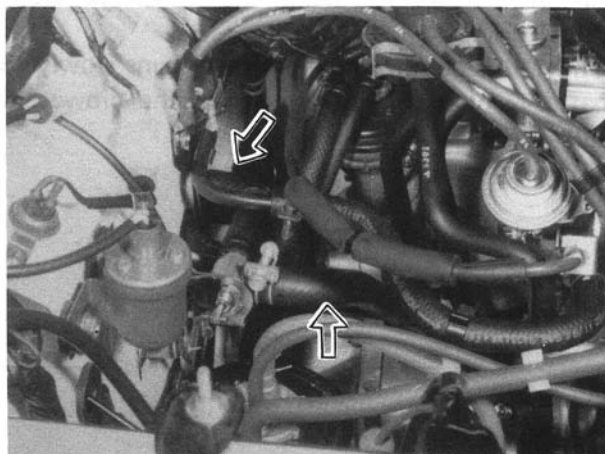


Fig. 7-4

## 7-4. REMOVAL AND INSTALLATION

### Removal

#### [Heater and blower motor]

1. Disconnect battery negative cable.
2. Drain cooling system.

#### WARNING:

To help avoid the danger of being burned, do not remove the drain plug and the radiator cap while the engine and radiator are still hot. Scalding fluid and steam can be blown out under pressure if the plug and cap are taken off too soon.

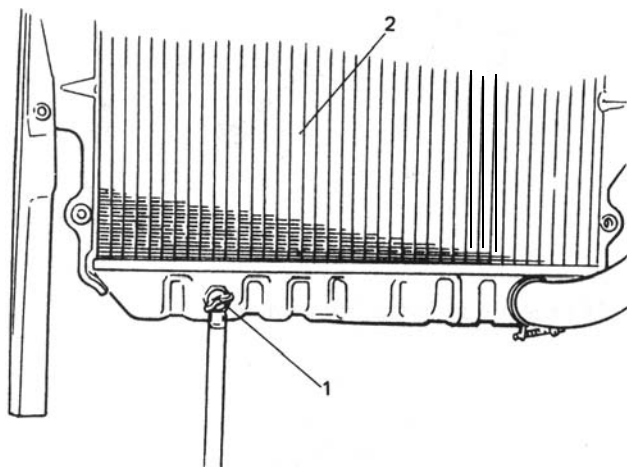


Fig 7-5 1. Drain plug 2. Radiator

3. Disconnect heater inlet and outlet hoses from heater unit pipes.
4. Remove instrument panel ass'y with speedometer ass'y as follows.
  - 1) Take off horn pad and remove steering wheel using special tool (A).

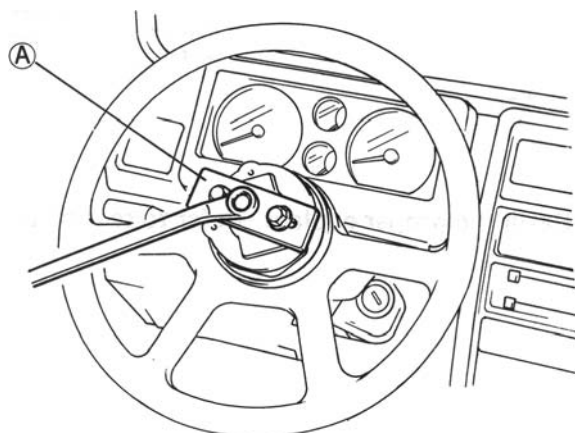


Fig. 7-6 (A) Special tool (Steering wheel remover 09944-360 10)

- 2) If equipped with radio and cigarette lighter, disconnect radio and cigarette lighter lead wires, and pull out radio case with radio and cigarette lighter after loosening case stay screw, and remove radio case bracket.
- 3) Pull out ashtray and loosen ashtray plate screws.
- 4) Disconnect front food opening cable from lock ass'y.
- 5) Loosen panel box stay screw and hood opening cable lock nut on back side of panel box cover.
- 6) Disconnect lead wires to control lever at the coupler and heater control cables.
- 7) Pull out lever knobs and plate, and loosen lever case screws.
- 8) Remove defroster and side ventilator hoses.
- 9) Disconnect lead wires to speedometer and switches installed instrument panel at the couplers.
- 10) Disconnect speedometer cable from speedometer.
- 11) Release wire harness clamps installed to instrument panel.
- 12) Loosen screws securing instrument panel.
- 13) Remove instrument panel.

#### NOTE:

- Before removing, recheck to ascertain all hoses, wire harness, cables and screws are disconnected from instrument panel.
  - When removing heater lever case which is fitted in steering column holder, be very careful not to damage it
5. Remove steering column holder after loosening front door open stopper screws.



Fig. 7-7

6. Disconnect heater blower motor and resistor lead wires at the coupler.
7. Loosen heater case securing nut on the engine room side.

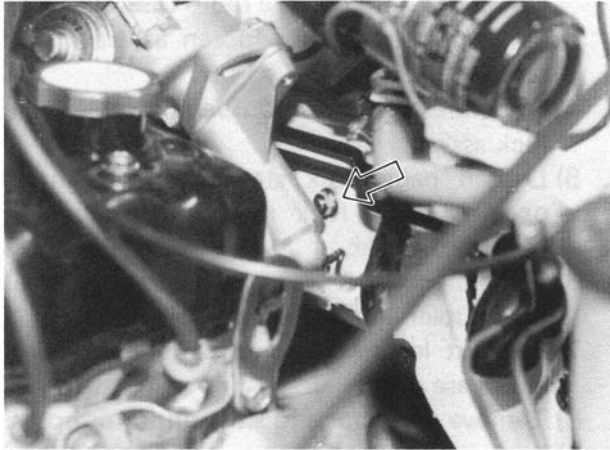


Fig. 7-8

6. Remove heater ass'v.



Fig. 7-9

9. Remove heater blower motor.

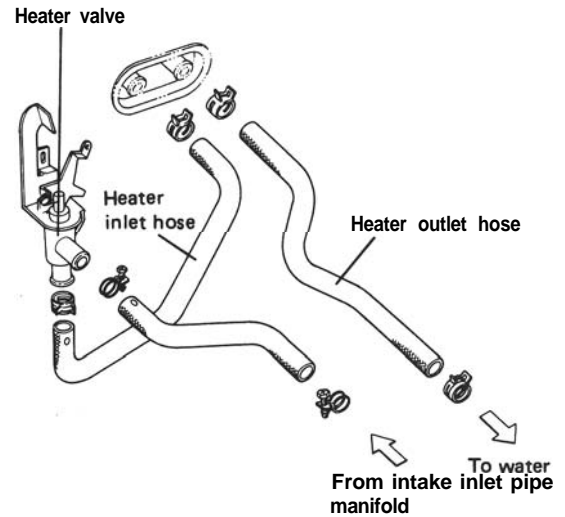
#### Installation

Reverse the removal procedure for installation, exercising care to the following.

1. Make definitely sure to insert holder plate between holder and body,
2. When installing parts, be careful to prevent wire harness from being caught between parts.
3. Clamp wire harness securely and make sure that it does not contact sharp edge of any part.

4. When connecting heater hoses, route them correctly making sure they are free from twist.

[For right hand steering vehicle]



[For left hand steering vehicle]

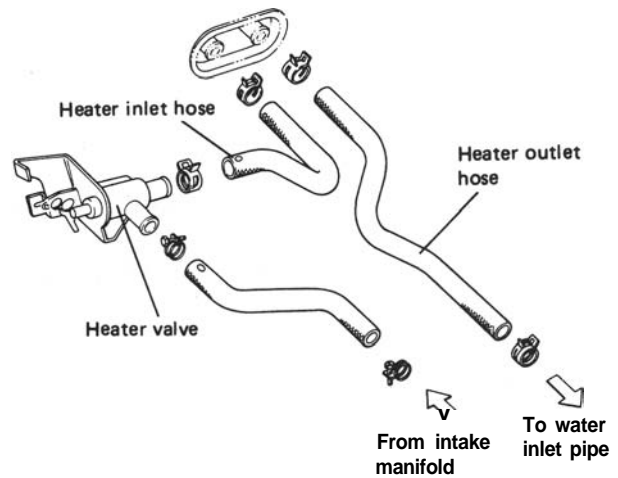


Fig. 7-10

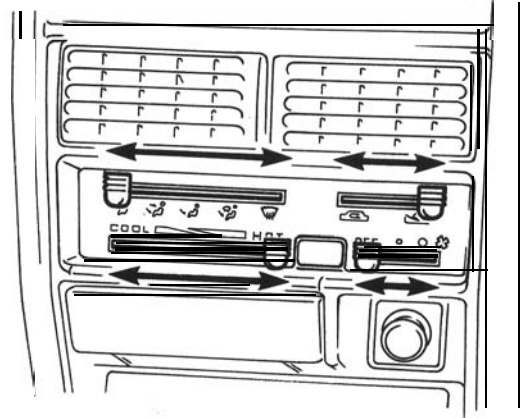
5. Refill the proper coolant. Refer to section 6.



**NOTE:**

Upon completion of all jobs, perform following checks.

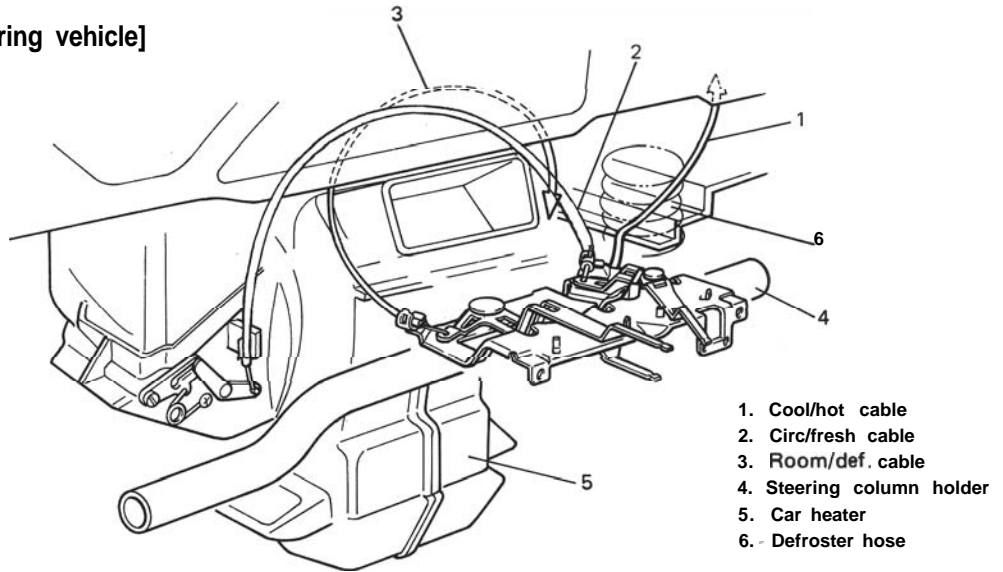
- Check to ensure that every joint of each heater hose and pipe is free from leakage of cooling water.
- Check to ensure that each control lever operates smoothly and that car heater operates correctly to each control lever position.  
If found faulty, adjust by changing control cable clamp position.
- Check to ensure that each wire harnesses are securely clamped.



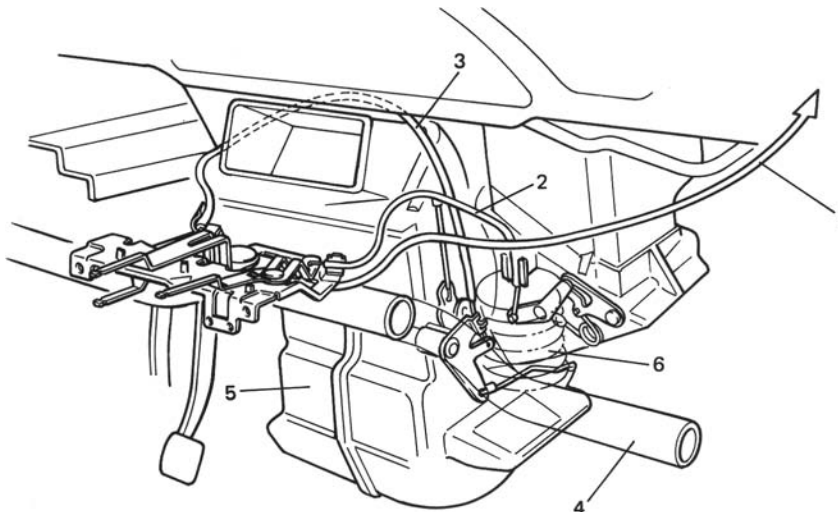
*Fig. 7 - 17*

**Heater & Ventilator Control Cable Routing**

[For right hand steering vehicle]



[For left hand steering vehicle]



# SECTION 8

## IGNITION SYSTEM

### CONTENTS

8-1. GENERAL DESCRIPTION .....	8-2
DISTRIBUTOR .....	8-3
IGNITION COIL .....	8-4
SPARK PLUG .....	8-4
8-2. MAINTENANCE SERVICE .....	8-5
HIGH TENSION CORD .....	8-5
SPARK PLUG .....	8-5
IGNITION COIL .....	8-5
DISTRIBUTOR .....	8-5
IGNITION TIMING .....	8-9
DISTRIBUTOR DRIVE GEAR .....	8-10
8-3. IMPORTANT REMINDERS FOR INSTALLATION .....	8-11
DISTRIBUTOR .....	8-11

## 8-1. GENERAL DESCRIPTION

The ignition system is of contact-pointless type (full-transistorized type).

The principal components of the ignition system are spark plugs, ignition coil, and distributor. The distributor has a rotor, an ignitor, a signal generator, a vacuum advancer and a centrifugal advancer.

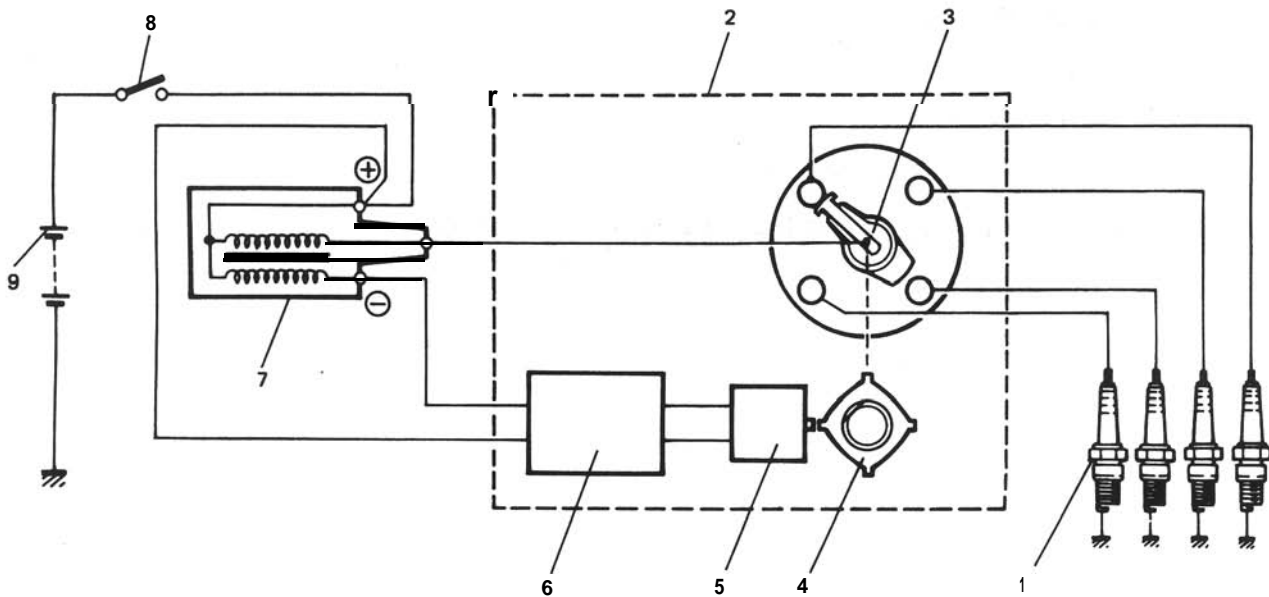
The signal generator is to generate the ignition signal and consists of a signal rotor, a magnet and a pickup coil. The signal rotor is attached to the distributor shaft, and the magnet and the pickup coil are attached to the generator base plate.

When the distributor shaft rotates, the magnetic flux passing through the pickup coil varies due to the change in air gap between the pickup coil and the signal rotor. As a result, the alternating current voltage is induced in the pickup coil. The voltage induced turns on and off the ignitor which switches off the ignition coil primary current. Thus, the high voltage is induced in the secondary winding of ignition coil and ignition sparks are generated at the spark plugs.

The distributor is a sort of rotary switch, whose rotor connects the four plugs, one at a time, to secondary winding of the ignition coil through the wires called "high-tension" cords. Note that there are one high-tension cord, from secondary winding to the center of the distributor cap, and four more high-tension cords between the spark plugs and the four terminals on the cap.

### NOTE:

Whereabouts of terminal connections are clearly indicated in the diagram below. When inspecting the electrical wiring, refer to this diagram and check to be sure that each connection is tight. Examine the cords for torn insulation and for evidence of grounding.



1. Spark plug
2. Distributor
3. Distributor rotor
4. Signal rotor
5. Generator
6. Ignitor
7. Ignition coil
8. Ignition switch
9. Battery

Fig. 8-1

# Distributor

1. Vacuum controller
2. Distributor cap
3. Seal
4. Distributor housing
5. Distributor driven gear
6. Pin
7. O-ring
8. Rotor
9. Signal generator dust cover
10. Ignitor dust cover
11. Signal generator
12. Ignitor
13. Generator base plate
14. Signal rotor

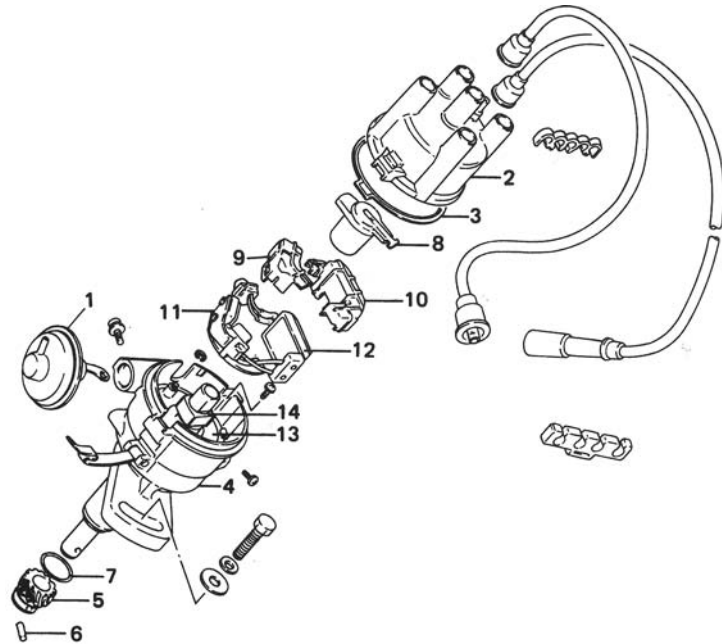


Fig. 8-2

## [Timing advancer]

The distributor shaft, from its driven-gear end to the rotor-carrying end, is not a single solid piece; actually this shaft is in two pieces connected together through the timing advancer. The advancer is essentially a flyweight mechanism. Timing advancing action is accomplished by twisting the top shaft piece relative to the bottom one in the direction of shaft rotation. The single rotor is mounted on the top piece. The twisting movement is produced by the speed-dependent radial (or spreading) movements of the two flyweights.

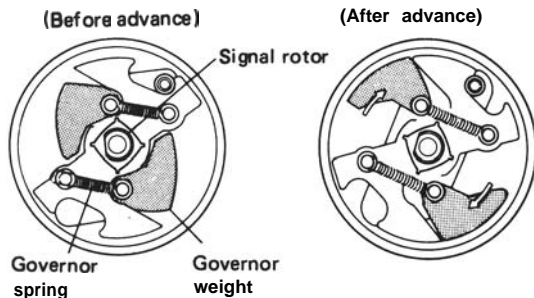


Fig. 8-3

## [Vacuum advancer]

In this vacuum-advance mechanism, when the vacuum in the carburetor gets high, the pressure acting on the diaphragm overcomes the spring force in it and the controller rod attached to the diaphragm is pulled. And the rod so pulled turns the generator base plate counter to the direction of the distributor shaft rotation (counterclockwise) to advance (quicken) the ignition.

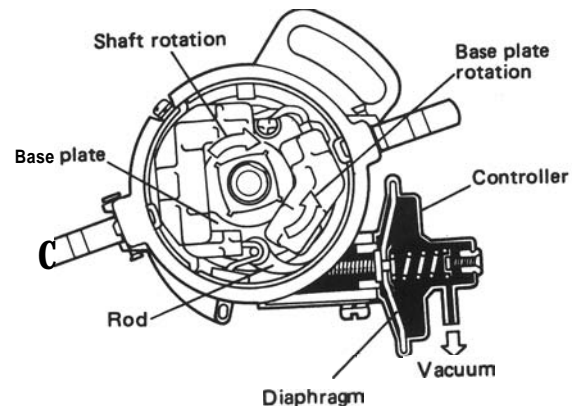


Fig. 8-4

## Ignition Coil

The ignition coil is a sort of miniature transformer and, as such, has an iron core around which two coils are wound – primary and secondary windings mentioned above. The two are so close to each other that a sudden change in the magnetic flux produced by “primary current” flowing in primary winding (in a less number of coil turns) induces a very large electromotive force (voltage) in secondary winding (in a greater number of coil turns). These live parts are housed in a tight, insulator case topped by the cap. Note that the cap has three terminals: one high-tension terminal and two low-tension terminals.

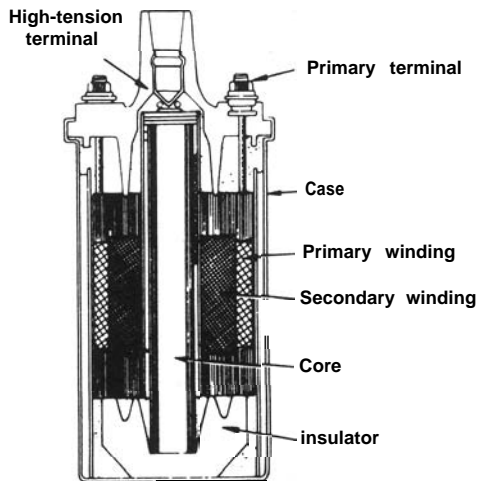


Fig. 8-5

## Spark Plugs

Each new machine shipped from the factory is fitted with standard plugs.

	Standard type	Cold type
NGK	<b>BPR-5ES</b>	<b>BPR-6ES</b>
Nippon Denso	<b>W16EXR-U</b>	<b>W20EXR-U</b>

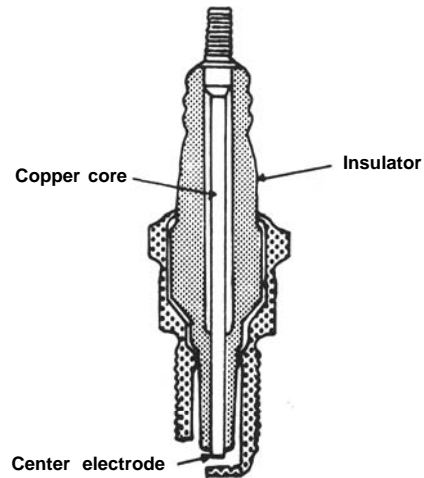


Fig. 8-6

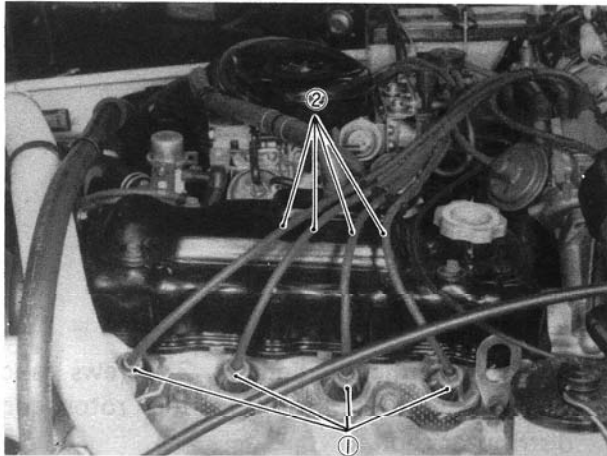
## 8-2. MAINTENANCE SERVICE

### High Tension Cords

Check cord terminals for corrosion, breaks and distortion, and cords for crack or deterioration. Replace cord as necessary.

#### NOTE:

DO NOT bend or pull high tension cords to avoid inside damage. Grip rubber boot when removing or installing cords.



1. Rubber boot
2. High tension cord

Fig. 8-7

### Spark Plugs

Check following:

- Electrode wear
- Carbon deposits
- Insulator damage.

If any fault is found, replace plugs.

Check gap, and make sure that gap is within specification. If gap is out of specification, adjust it by bending ground (side) electrode.

Plug gap "A"	0.7 – 0.8 mm (0.027 – 0.031 in.)
--------------	-------------------------------------

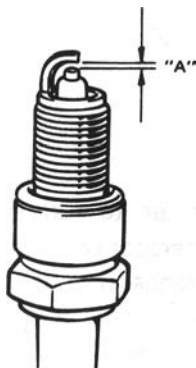


Fig. 8-8

### Ignition Coil

Disconnect negative cable at battery. Disconnect lead wires and high tension cord from ignition coil. Remove ignition coil, and check it as follows.

Measure primary coil resistance.

Using ohmmeter, measure resistance between positive  $\oplus$  and negative  $\ominus$  terminals.

Primary coil resistance	1.35 – 1.65 $\Omega$
-------------------------	----------------------

Measure secondary coil resistance.

Using ohmmeter; measure resistance between positive  $\oplus$  terminal and high tension terminal.

Secondary coil resistance	11.0 – 14.5 k $\Omega$
---------------------------	------------------------

#### NOTE:

Take readings when coil is about 20° C (66° F).



Fig. 8-9

Reverse removal procedure for installation.

When reinstalling, make sure that each connection is tight.

### Distributor

[Distributor cap]

Leakage of high-tension energy for ignition shows up as misfiring in the engine. It occurs at any part of the high-tension line where insulation has failed or in a dirty distributor cap, that is, an internally dirty cap.

A wider spark gap in the plug, a condition often found in poorly cared spark plugs, promotes a tendency of high-tension energy to find a short-cut to ground.

Cleanliness is very important for the distributor cap. With a clean dry cloth, wipe off dust or grime, if any, and inspect for any damaged (scarred, scratched or cracked) part or any part evidencing high-tension leakage inside the cap. Be sure to replace such parts.

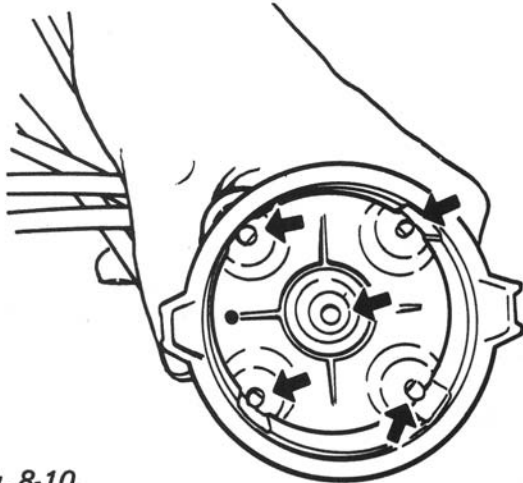


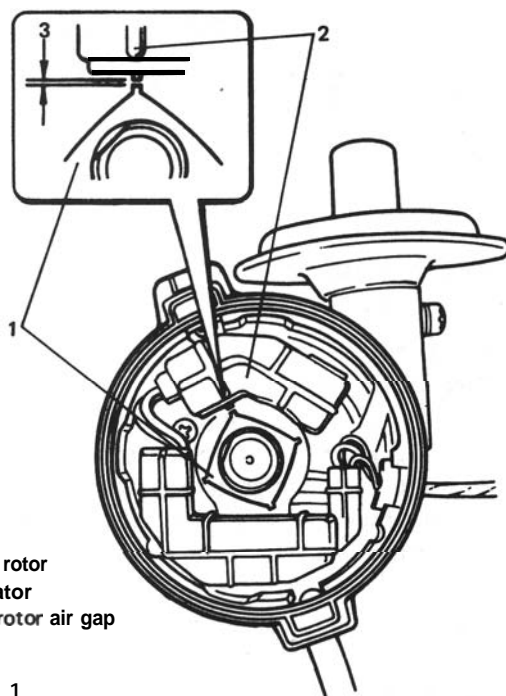
Fig. 8-10

[Signal rotor air gap]

Signal rotor air gap	0.2– 0.4m m (0.008– 0.016 n)
----------------------	---------------------------------

Check air gap and adjust it as necessary.

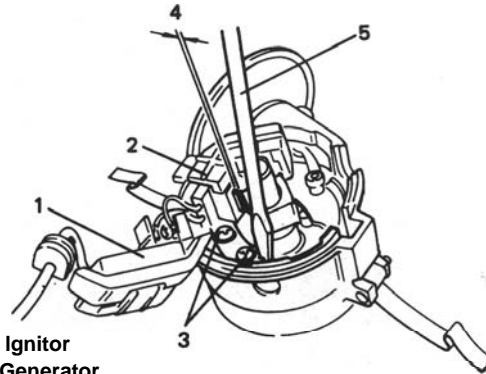
1. Remove distributor cap and rotor.
2. Using thickness gauge, measure air gap between signal rotor tooth and generator.



1. Signal rotor
2. Generator
3. Signal rotor air gap

Fig 8-1 1

3. If air gap is out of specification, adjust it. Remove distributor and then ignitor. Loosen 2 screws securing generator. Using blade (-) screwdriver, move generator and adjust air gap to specification.



1. Ignitor
2. Generator
3. Generator screw
4. Signal rotor air gap
5. Blade screwdriver

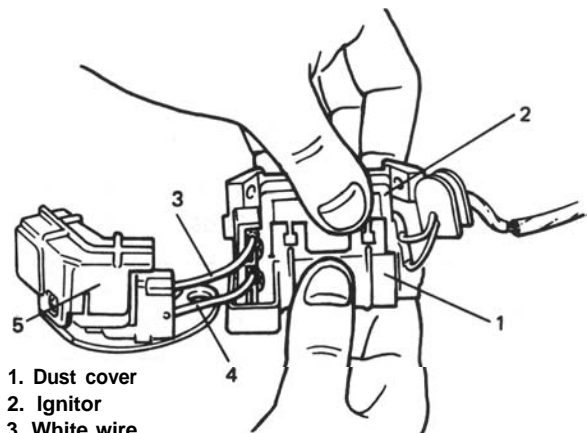
Fig. 8-1 2

After adjustment, tighten 2 screws and recheck air gap. Install ignitor, rotor and distributor cap.

Install distributor referring to p. 8-11.

[Generator]

1. Disconnect negative cable at battery. Remove distributor, and then ignitor and generator.
2. Remove dust cover from ignitor.
3. Disconnect red and white wires from ignitor.

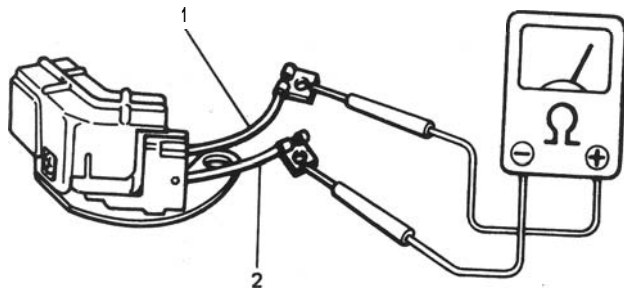


1. Dust cover
2. Ignitor
3. White wire
4. Red wire
5. Generator

Fig. 8-1 3

4. Connect ohmmeter to red and white wires, and measure generator resistance. Generator resistance should be within 130 – 190 ohms. If resistance is not within specification, replace the generator.

Generator (Pickup coil) resistance	130 – 190 ohms
------------------------------------	----------------

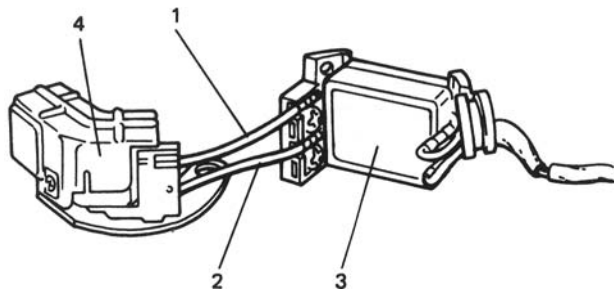


1. White wire
2. Red wire

Fig. 8-14

5. After checking, connect red and white wires to ignitor as shown in Figure 8-15, and then install dust cover.

**NOTE:**  
NEVER connect red and white wires reversely. Reverse connection may cause damage to generator and ignitor.



1. White wire
2. Red wire
3. Ignitor
4. Generator

Fig. 8-15

6. After generator has been assembled on distributor, make sure to adjust air gap and install ignitor.  
7. Install distributor referring to page 8-11.

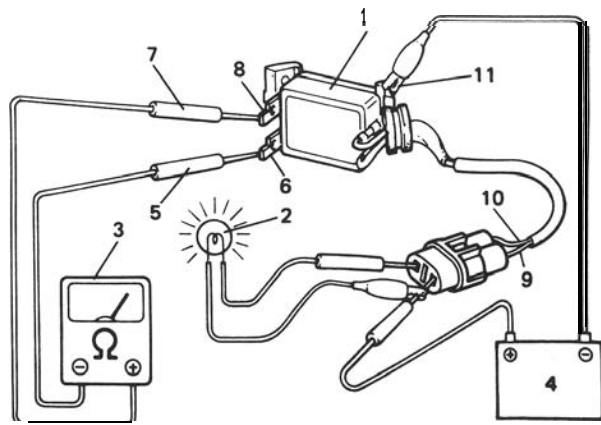
### [ Ignitor]

1. Disconnect negative cable at battery. Remove distributor, and then ignitor and generator.
2. Remove dust cover from ignitor.
3. Disconnect red and white wires from ignitor.
4. Connect an ohmmeter, a bulb and 12 voltage battery to ignitor as shown in Figure 8-16.

Set ohmmeter at 1 ohm to 10 ohm range. Then bring ohmmeter negative  $\ominus$  prod to touch red wire terminal of ignitor, and positive  $\oplus$  prod to touch white wire terminal. If bulb is illuminated, it indicates that ignitor is satisfactory. If not, replace ignitor.

### NOTE:

- Never connect battery positive and negative wires reversely. Reverse connection may cause damage to ignitor.
- Under no circumstances should ohmmeter be connected reversely.
- Be sure to perform this ohmmeter check within a short time (two to three seconds).



1. Ignitor
2. Bulb
3. Ohmmeter
4. Battery (12V)
5. Negative prod
6. Red wire terminal
7. Positive prod
8. White wire terminal
9. Black/White wire
10. Brown wire
11. Earth

Fig. 8-16

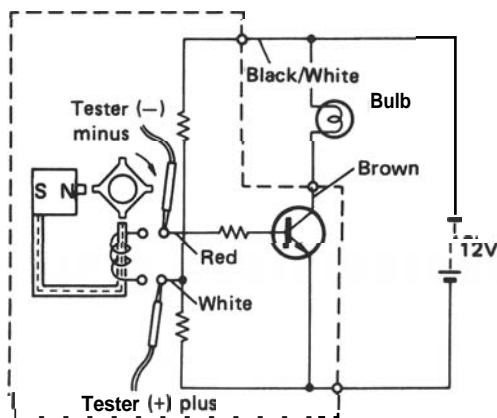


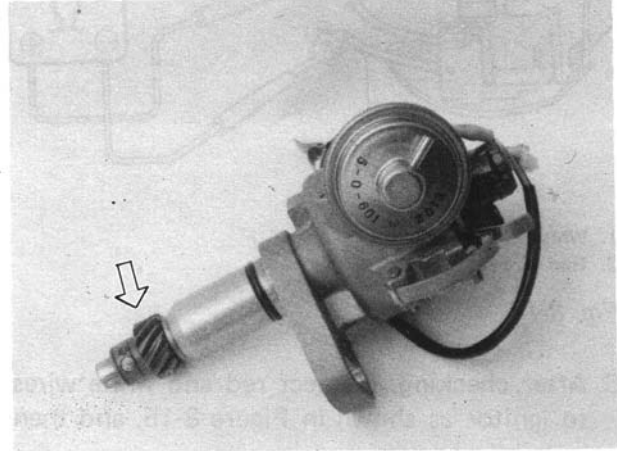
Fig. 8-17



5. After checking, connect red and white wires of generator to ignitor and install dust cover on ignitor.  
Refer to Fig. 8-15 for proper connection of red and white wires.
6. After the generator and ignitor have been assembled on the distributor, make sure to adjust the air gap.
7. Install distributor referring to page 8-11.

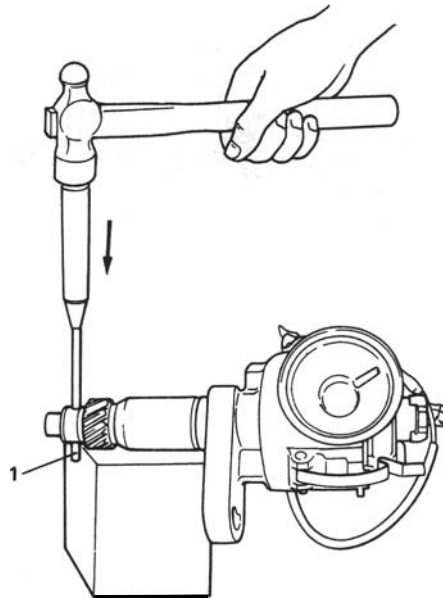
**[Distributor driven gear]**

Inspect gear teeth for wear, and see if the backlash is normal or not. Excessive backlash can be told by turning the shaft back and forth, with its driven gear in mesh with driving gear. Maladjusted ignition timing is often due to excessive tooth wear in this gearing and, in such a case, can be corrected by replacing driven gear.



*Fig. 8-18*

To replace driven gear, grind off both caulked ends of driven gear set pin with grinder and drive it off. After fitting new gear, make sure to use a new pin and caulk its both ends.



*Fig. 8-19*

1. Driven gear set pin

## Ignition Timing

Ignition timing	10° BTDC at 800 ± 50 r/min
Ignition order	1 - 3 - 4 - 2

When checking and adjusting ignition timing, be sure to use timing light (09900-27301 or 09900-27311).

### NOTE:

Prior to check and adjustment of ignition timing, make sure that head lights, heater fan, rear defogger (if equipped), and air conditioner (if equipped) are "OFF". If any one of these systems is "ON", idle up system operates and engine idle speed will be out of the specification.

### [Checking]

1. Remove rubber plug from timing check window on the transmission case.
2. Start engine and warm it up to normal operating temperature.
3. After warming up, check to be sure that idle speed is within specification. If idle speed is out of specification, adjust it by turning idle speed adjusting screw of carburetor.
4. Connect timing light to high tension cord of No. 1 cylinder.
5. With engine running at specified idle speed, direct the timing light to timing check window. If 10° BTDC timing mark ① on flywheel appears aligned to timing match mark ②, ignition is properly timed.

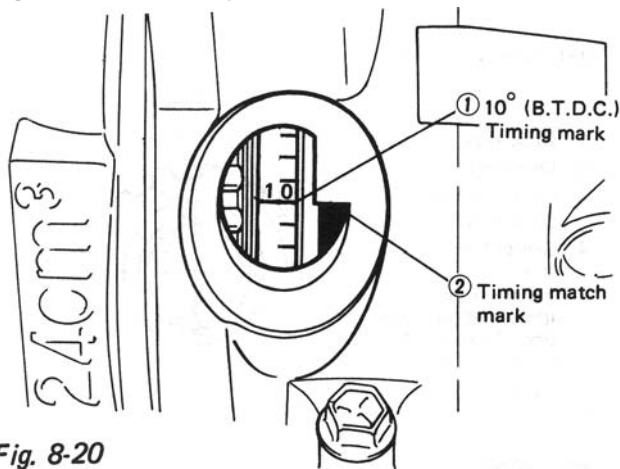


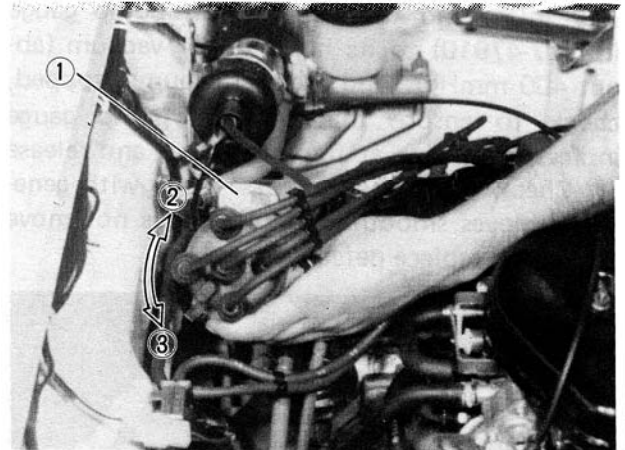
Fig. 8-20

### [Adjusting]

If ignition timing is out of specification, adjust it.

Loosen distributor flange bolt and turn distributor housing in place to advance or retard timing.

Turning housing counterclockwise advances timing, and vice versa. After adjustment, tighten flange bolt and recheck timing.



1. Distributor flange bolt
2. Timing is retarded
3. Timing is advanced

Fig. 8-21

Be sure to re-install check window rubber plug after making above check and adjustment.

### WARNING:

When engine is warmed up, exhaust manifold cover and other parts are hot as well. Be careful not to touch them when removing and reinstalling rubber plug.

### [Checking centrifugal advancer]

After removing distributor cap, turn rotor clockwise by finger and release it. Check that rotor returns smoothly counterclockwise by spring force.

If defective, replace distributor.

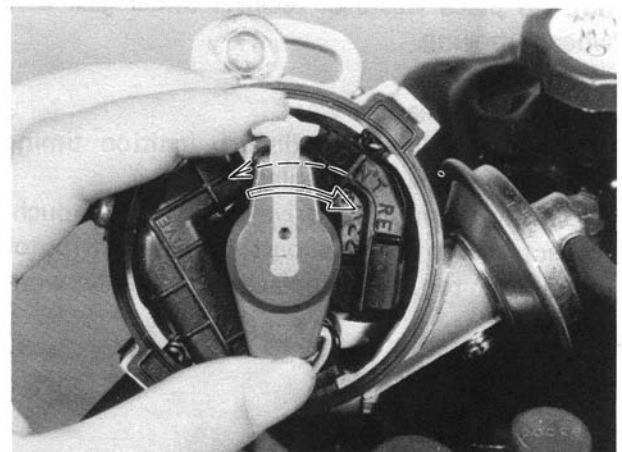
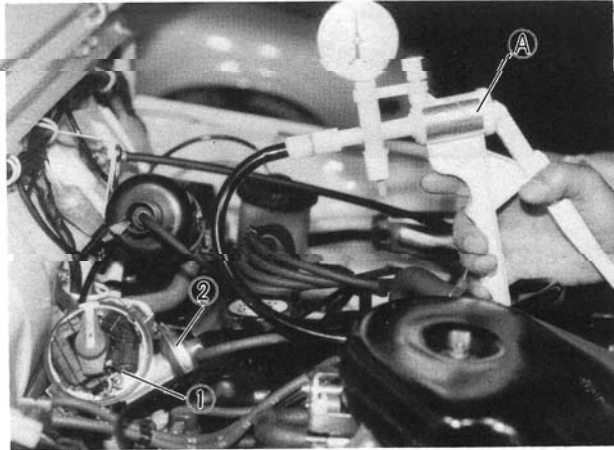


Fig. 8-22

**[Checking vacuum advancer]**

Remove distributor cap.

Disconnect vacuum hose from vacuum hose 3 way joint, and connect vacuum pump gauge (0991747910) to its hose. Apply vacuum (about 400 mmHg). And then with pump stopped, check to ensure that vacuum pump gauge indicator remains at the same level, and release it. Check that generator base plate with generator moves smoothly. If plate does not move smoothly, replace defective parts.



Ⓐ Vacuum pump gauge (09917-47910)  
 1. Generator base plate  
 2. Vacuum controller

Fig. 8-23

**Distributor Drive Gear**

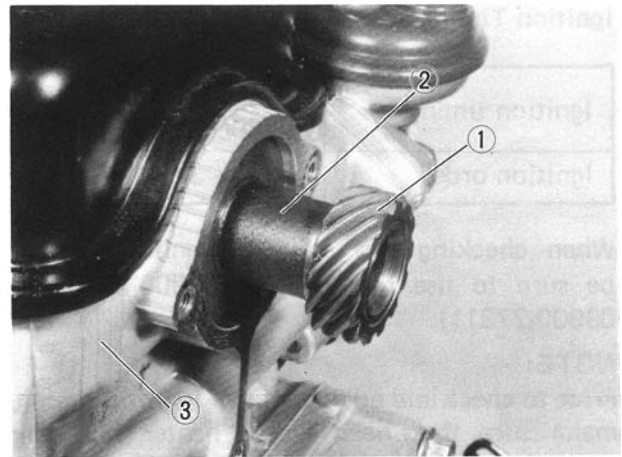
**NOTE:**

When removing distributor gear case from cylinder head, engine oil in cylinder head may come out. So place waste or receiver under gear case when removing.

Inspect drive gear for wear.

Worn gear is likely to disturb ignition timing and therefore must be replaced.

Replacing worn-down drive gear is not enough. Inspect driven gear (a part of the distributor assembly), too, and replace it if badly worn down.



1. Distributor drive gear  
 2. Camshaft  
 3. Cylinder head

Fig. 8-24

**[Important reminders for removal and installation]**

- Before removing drive gear from camshaft, scribe a match mark on this shaft to root center line of drive gear as shown in Fig. B-25 and, when mounting replacement drive gear, refer to this mark.
- When pressing replacement drive gear onto camshaft, be sure to position gear angularly as shown in Fig. B-25. (align mark on Camshaft scribed in removal with root center of drive gear)

**NOTE:**

There is no need to discriminate between two end faces of drive gear.

Distributor side view

1. Drive gear
2. Camshaft
3. Center line of  $\phi 5$  mm hole
4. Center line of root
5.  $\phi 5$  mm hole (Provided on pulley side of camshaft)
6. Scribed match mark
7.  $5^\circ$

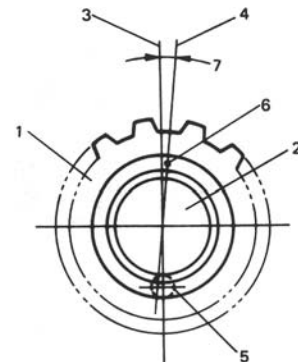


Fig. 8-25

- About 30 cc (1.01/1.05 US/Imp oz) of engine oil must be fed into distributor gear case after servicing this case, that is, removing and putting it back. Be sure to add this much oil before starting engine for the first time after servicing.

### 8-3. IMPORTANT REMINDERS FOR INSTALLATION

#### Distributor

When re-installing distributor, be sure to insert it into distributor gear case in the following sequence:

1. Turn over crankshaft in normal direction (clockwise as viewed from crankshaft pulley side) until specified timing mark @ on flywheel aligns with timing match mark ②.

#### CAUTION :

After aligning two marks, remove cylinder head cover to visually confirm that rocker arms are not riding on camshaft cams at No. 1 cylinder. If arms are found to be riding on cams, turn over crankshaft 360° to align two marks anew.

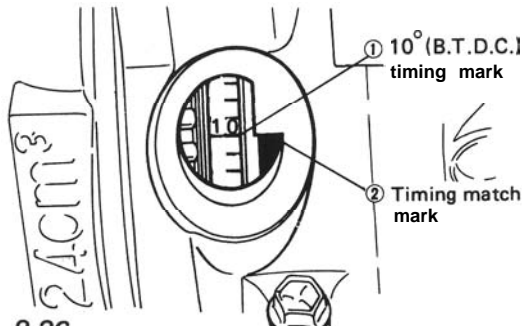


Fig. 8-26

2. Remove distributor cap, and turn rotor to make center of rotor align with cap clamp center on distributor housing as shown in figure.

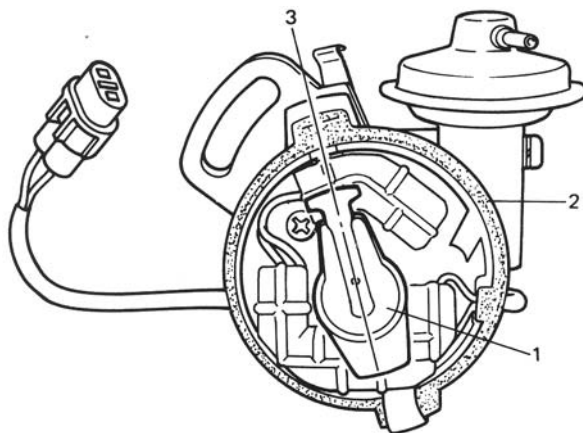


Fig. 8-27

- |            |                              |
|------------|------------------------------|
| 1. Rotor   | 3. Center of rotor and clamp |
| 2. Housing |                              |

3. Insert distributor into gear case in such a way that center of distributor flange will coincide with the distributor mounting screw hole provided in distributor gear case. When

distributor is inserted properly, position of distributor rotor becomes as shown in figure. Secure distributor in place tentatively by making mounting screw finger-tight.

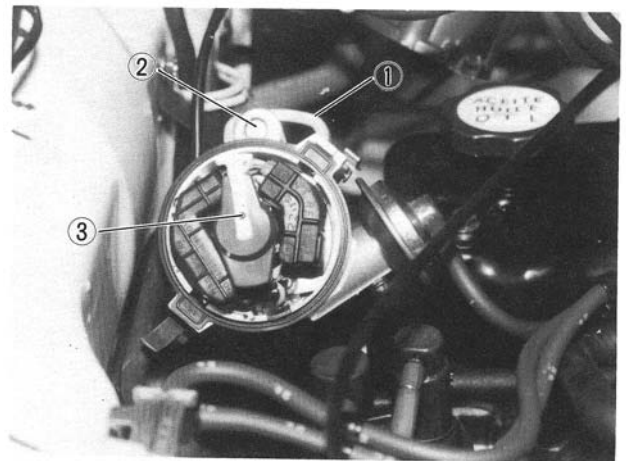


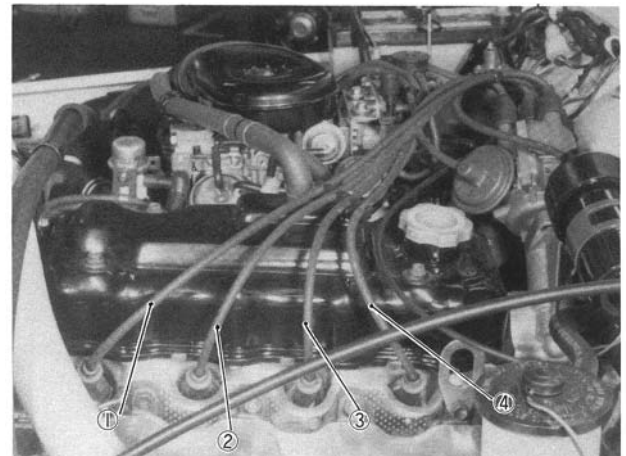
Fig. 8-28

- |                       |          |
|-----------------------|----------|
| 1. Distributor flange | 3. Rotor |
| 2. Mounting screw     |          |

4. Install cap gasket and distributor cap to distributor. Hook 2 clamps securely.
5. Distribute cords as shown in figure. Securely connect cords to distributor cap terminals and spark plugs.

#### NOTE:

Make sure to clamp high tension cords so that they do not contact other parts.



- |                   |                   |
|-------------------|-------------------|
| 1. No. 1 cylinder | 3. No. 3 cylinder |
| 2. No. 2 cylinder | 4. No. 4 cylinder |

Fig. 8-29 High tension cords distribution

6. Connect vacuum hose to vacuum controller, and coupler of lead wires.
7. Connect negative cable at battery.
8. Start engine and adjust ignition timing by using timing light as previously outlined. After adjustment, tighten distributor flange bolt.

## SECTION 9

# CRANKING SYSTEM

## CONTENTS

9-1.	GENERAL DESCRIPTION .....	9-2
9-2.	SPECIFICATIONS .....	9-4
9-3.	LUBRICATION .....	9-5
9-4.	REMOVAL AND INSTALLATION .....	9-5
9-5.	DISASSEMBLY .....	9-6
9-6.	STARTING MOTOR INSPECTION .....	9-7
	COMMUTATOR .....	9-7
	FIELD COIL .....	9-8
	BRUSH .....	9-8
	BRUSH HOLDER AND SPRING .....	9-9
	DRIVE LEVER .....	9-9
	PINION .....	9-9
	ARMATURE SHAFT BUSH .....	9-9
	MAGNETIC SWITCH .....	9-10
9-7.	PERFORMANCE TEST .....	9-11
	PULL-IN TEST .....	9-11
	HOLD-IN TEST .....	9-11
	PLUNGER RETURN .....	9-11
	PERFORMANCE TEST .....	9-11
9-8.	CLUTCH SWITCH .....	9-12

## 9-1. GENERAL DESCRIPTION

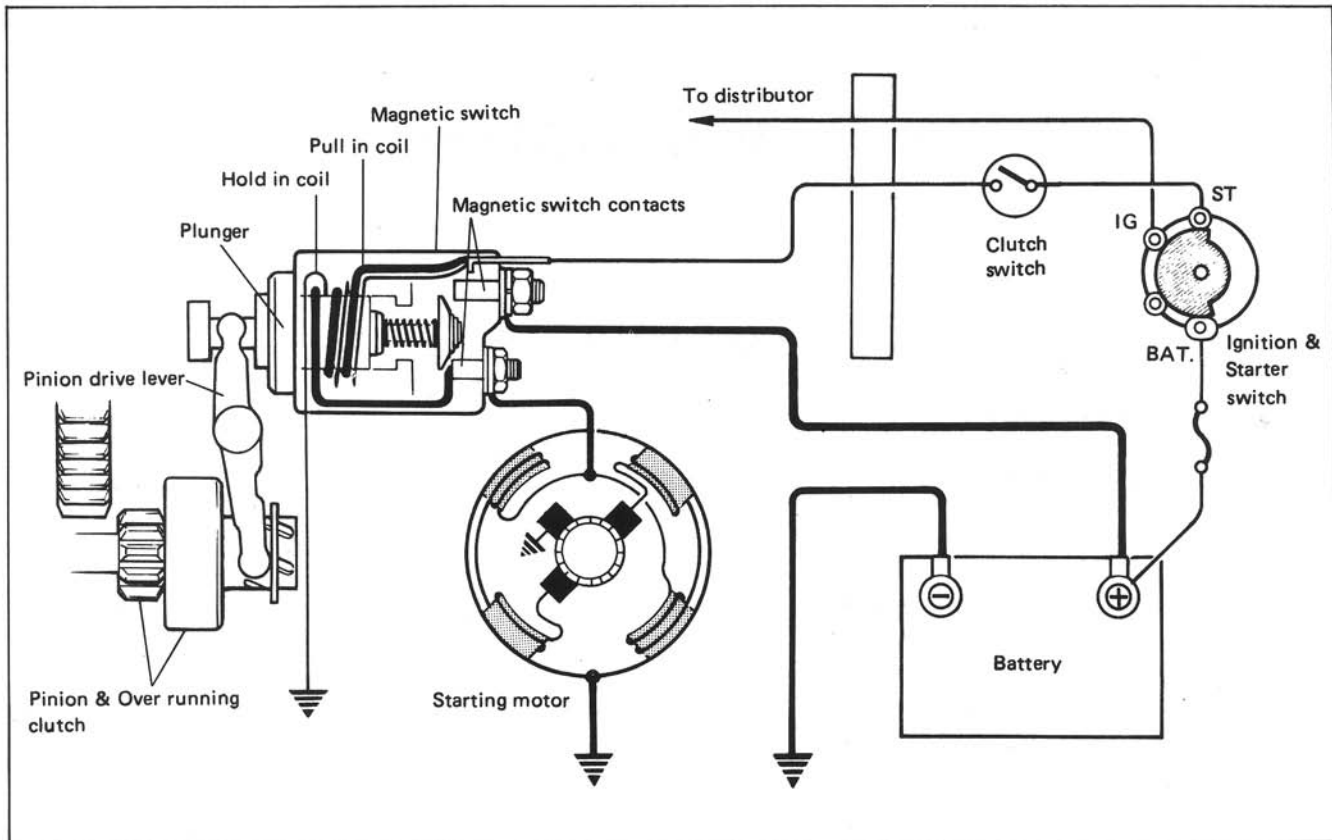


Fig. 9-1 Cranking circuit

### CRANKING CIRCUIT

The cranking circuit consists of the battery, starting motor, ignition switch, clutch switch and related electrical wiring. These components are connected electrically as shown in Fig. 9-1. Only the starting motor will be covered in this portion.

### STARTING MOTOR

The starting motor consists of parts shown in Fig. 9-2 and has field coils mounted in starting motor yoke (frame).

The magnetic switch assembly and parts in the starting motor are enclosed in the housings so that they will be protected against possible dirt and water splash.

In the circuit shown in Fig. 9-1, the magnetic (motor) switch coils are magnetized when the ignition switch is closed. The resulting plunger and pinion drive lever movement causes the pinion to engage the engine flywheel gear and the magnetic switch main contacts to close, and cranking takes place. When the engine starts, the pinion overrunning clutch protects the armature from excessive speed until the switch is opened, at which time the return spring causes the pinion to disengage.

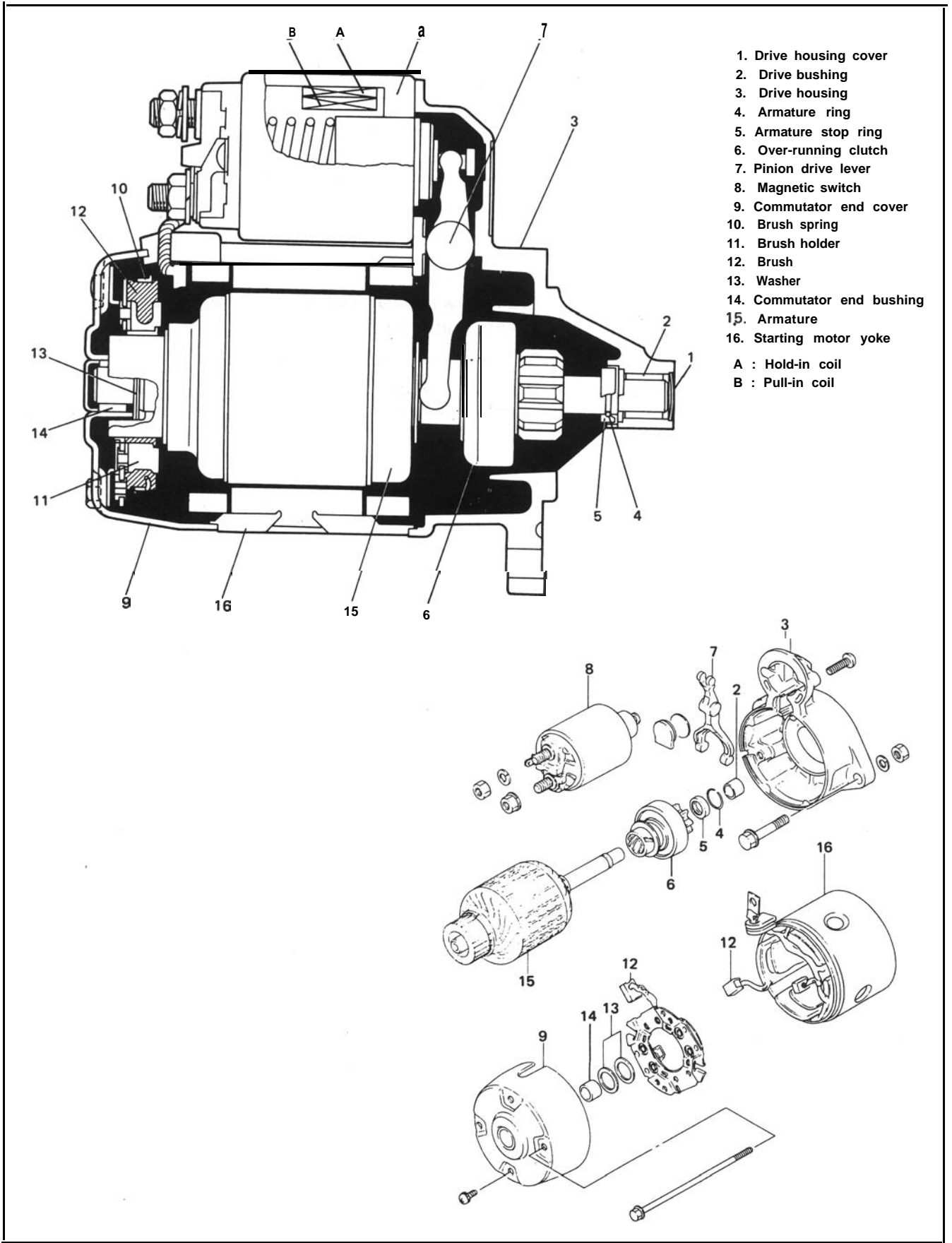


Fig. 9-2

## 9-2. SPECIFICATIONS

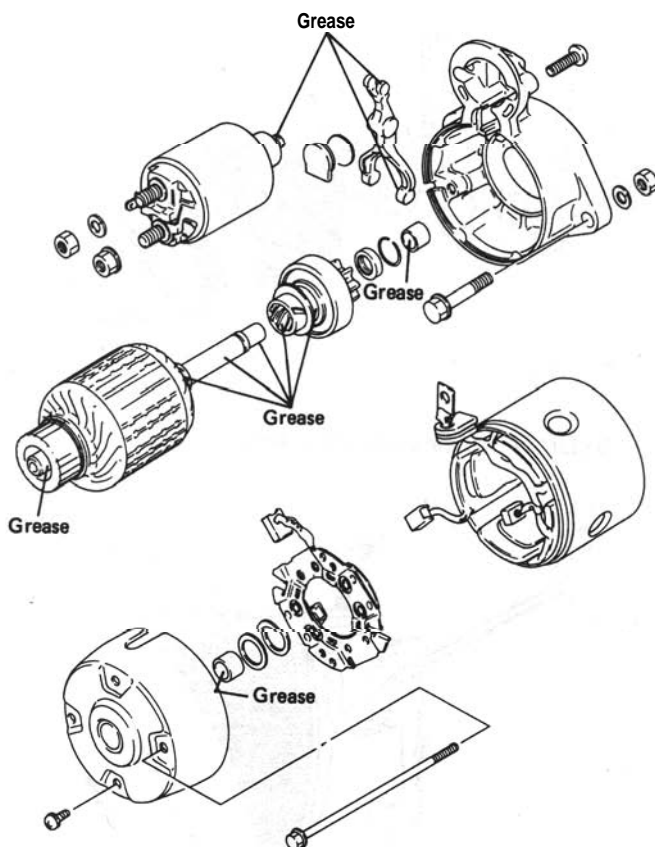
<b>Voltage</b>	<b>12 volts</b>
<b>output</b>	<b>0.9 kW</b>
<b>Rating</b>	<b>30 seconds</b>
<b>Direction of rotation</b>	<b>Clockwise as viewed from pinion side</b>
<b>Brush length</b>	<b>17 mm (0.67 in.)</b>
<b>Number of pinion teeth</b>	<b>6</b>
<b>No-load characteristic</b>	<b>60 A maximum at 11.5 volts, 6,600 r/min minimum</b>
<b>Load characteristic</b>	<b>150 A maximum at 9 volts and 0.29 kg-m torque, 1,900 r/min minimum</b>
<b>Locked rotor current</b>	<b>500A maximum at-5 volts, 1.15 kg-m minimum</b>
<b>Magnetic switch operating voltage</b>	<b>8 volts maximum</b>



### 9-3. LUBRICATION

The starting motor does not require lubrication except during overhaul.

When the motor is disassembled for any reason, lubricate as follows:



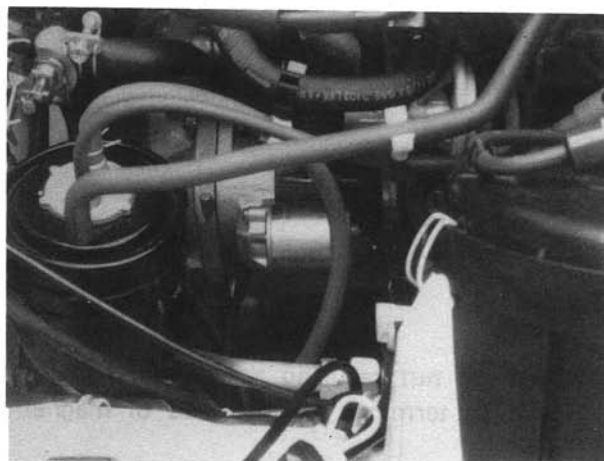
Bearing grease  
SUZUKI SUPER GREASE A  
99000-25010

**Fig. 9-3 Starting motor greasing point**

### 9-4. REMOVAL AND INSTALLATION

Use following procedure to remove starter:

- 1) Disconnect negative battery lead at battery.
- 2) Disconnect magnetic switch lead wire (BLACK/YELLOW) and battery cable from starting motor terminals.
- 3) Remove two starting motor mount bolts.
- 4) Remove starting motor.
- 5) To install, reverse the above procedure.



**Fig. 54 Starting motor mounting**

## 9-5. DISASSEMBLY

### NOTE:

Before disassembling starting motor, be sure to put match marks at two locations (A and B) as shown in the figure below so that any possible mistakes can be avoided.

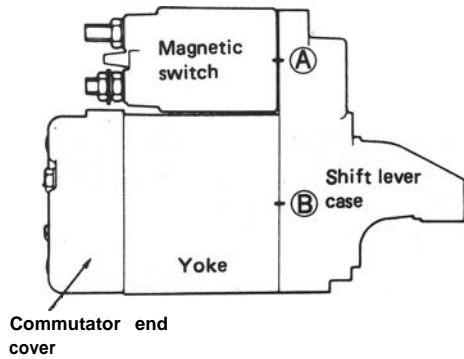


Fig. 95

- 1) Remove nut securing the end of field coil lead to terminal on the head of magnetic switch.

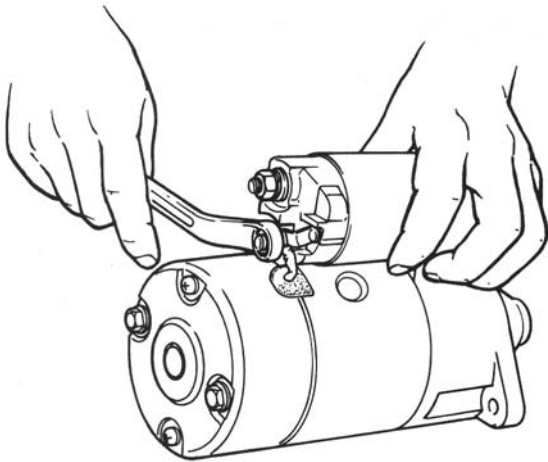


Fig. 9-6

- 2) Take off magnetic switch ① from starting motor body by removing two mounting screws.

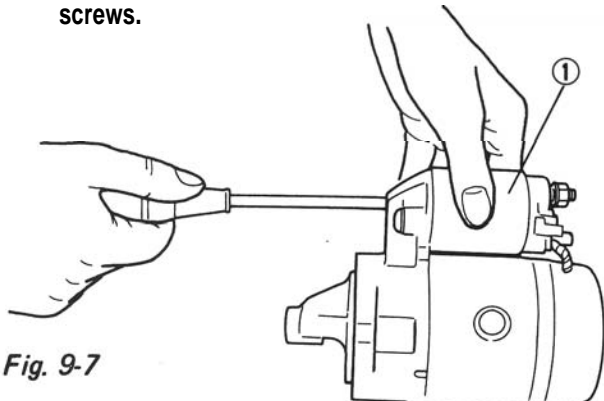


Fig. 9-7

- 3) Loosen 2 bolts and 2 screws to remove commutator end cover.
- 4) Separate drive housing and armature from yoke.

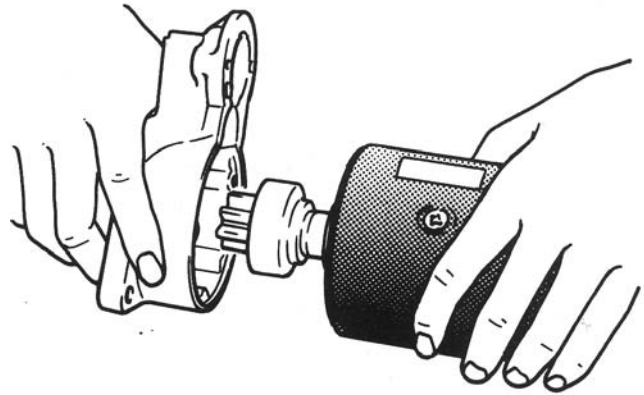


Fig. 9-8

- 5) Draw brushes out of holder.

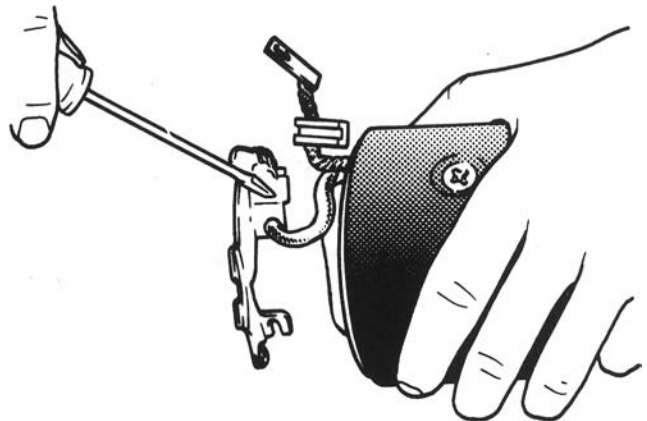


Fig. 49

- 6) Draw off over running clutch, as follows:
  - (1) Draw stop ring ① toward clutch side.
  - (2) Remove armature ring ② and slide off clutch.

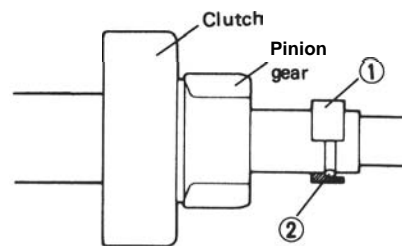


Fig. 910

## 96. STARTING MOTOR INSPECTION

### 1) Inspect Commutator

Inspect commutator for dirt or burn. Correct with sandpaper or lathe, if necessary.

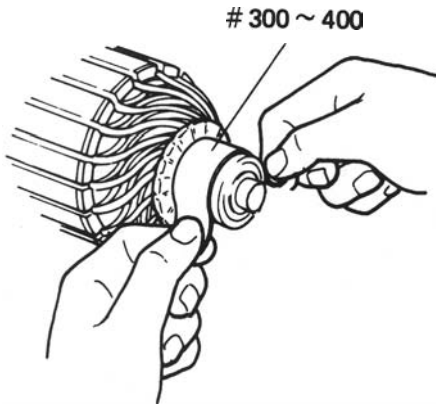


Fig. 9-11

Check commutator for uneven wear. If deflection of dial gauge pointer exceeds limit, repair or replace.

#### NOTE:

Below specification presupposes that armature is free from bend. Bent shaft must be replaced.

	Standard	Limit
Commutator out of round	0.05 mm (0.0019 in.) or less	0.4 mm (0.015 in.)

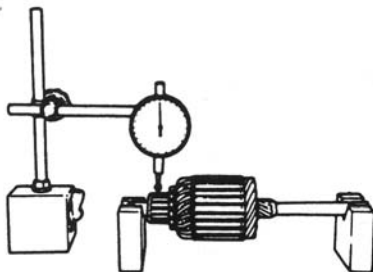


Fig. 912

Inspect commutator for wear. If below limit, replace armature.

	Standard	Limit
Commutator outside diameter	32 mm (1.26 in.)	31 mm (1.22 in.)

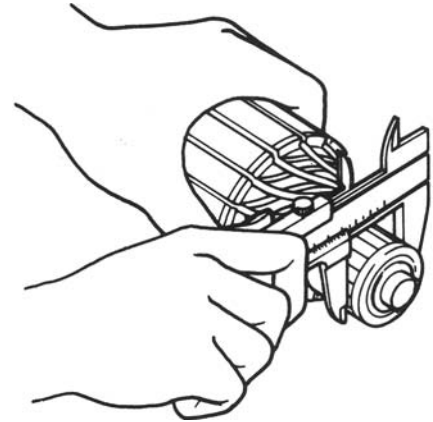


Fig. 9- 13

Inspect commutator for mica depth. Correct or replace if below limit.

	Standard	Limit
Commutator mica depth	0.4 – 0.6 mm (0.015 – 0.023 in.)	0.2 mm (0.0076 in.)

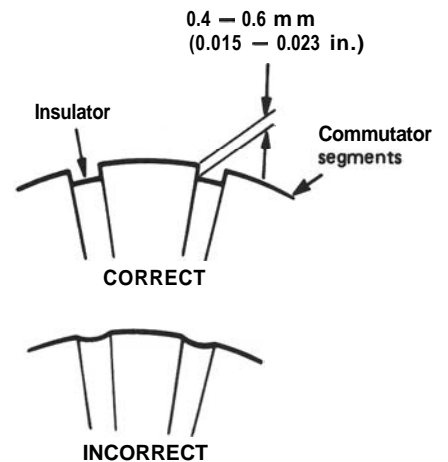


Fig. 9- 14

### Ground test

Check commutator and armature coil core. If there is continuity, armature is grounded and must be replaced.

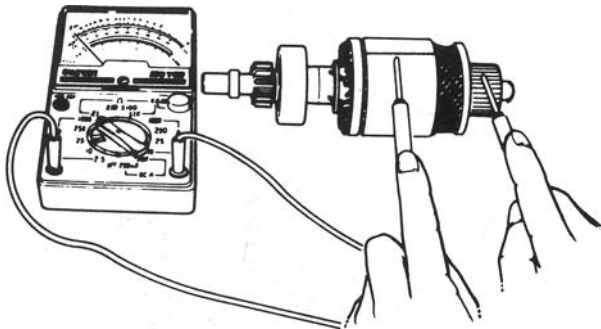


Fig. 9-15

### Open circuit test

Check for continuity between segments. If there is no continuity at any test point, there is an open circuit and armature must be replaced.

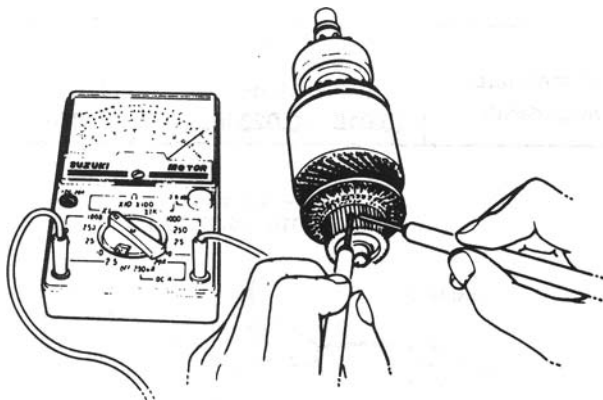


Fig. 9-16

### 2) Inspect Field Coil

#### Open circuit test

Check for continuity between brush and bare surface. If there is continuity, field windings are grounded. The field coil must be replaced.

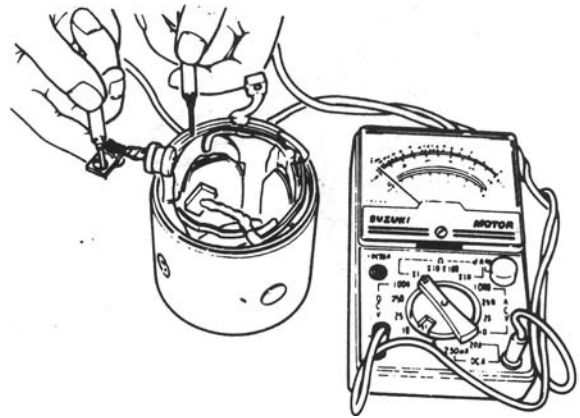


Fig. 917

### 3) Inspect Brush

Check brushes for wear. If below limit, replace brush.

	Standard	Limit
Brush length	17 mm (0.67 in.)	11.5 mm (0.45 in.)

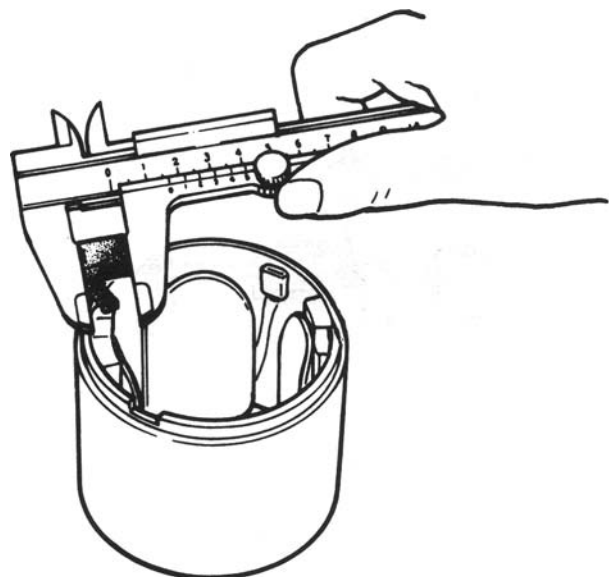


Fig. 918

#### 4) Inspect Brush Holder and Spring

Check movement of brush in brush holder. If brush movement within brush holder is sluggish, check brush holder for distortion and sliding faces for contamination.

Clean or correct as necessary.

Check for continuity across insulated brush holder (positive side) and grounded brush holder (negative side).

If continuity exists, brush holder is grounded due to defective insulation and should be replaced.

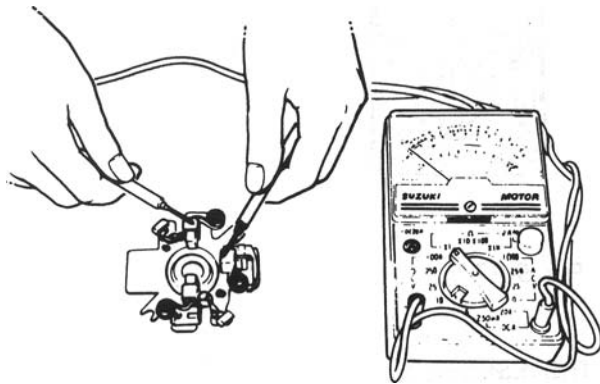


Fig. 9- 19

Inspect brush spring for wear, damage or other abnormal conditions. Replace if necessary.

Brush spring tension	Standard	Limit
	1.6 kg (3.53 lb)	1.0 kg (2.20 lb)

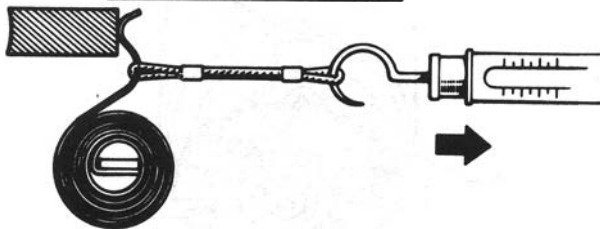


Fig. 9-20

#### 5) Inspect Drive Lever

Inspect drive lever for wear. Replace if necessary.

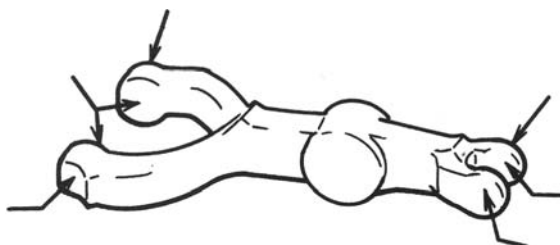


Fig. 921

#### 6) Inspect Pinion

Inspect pinion for wear, damage or other abnormal conditions. Check that clutch locks up when turned in direction of drive and rotates smoothly in reverse direction. Replace if necessary.

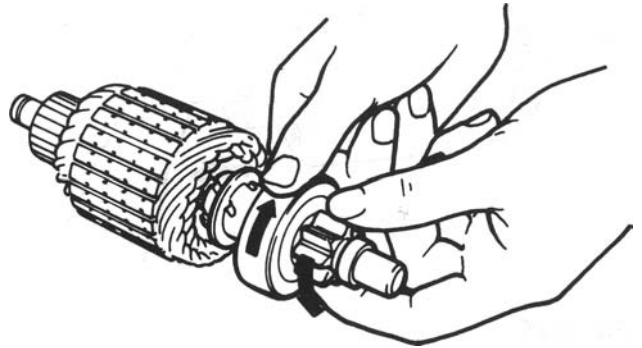


Fig. 9-22

Inspect spline teeth for wear or damage. Replace if necessary. Inspect pinion for smooth movement.

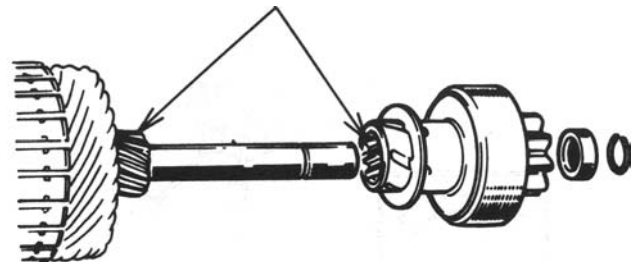


Fig. 923

#### 7) Inspect Armature Shaft Bush

Inspect bushes for wear or damage. Replace if necessary.

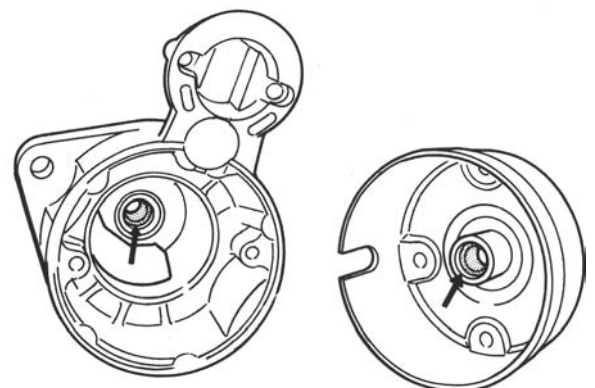


Fig. 9-24

### 8) Inspect Magnetic Switch

Push in plunger and release it. The plunger should return quickly to its original position. Replace if necessary.

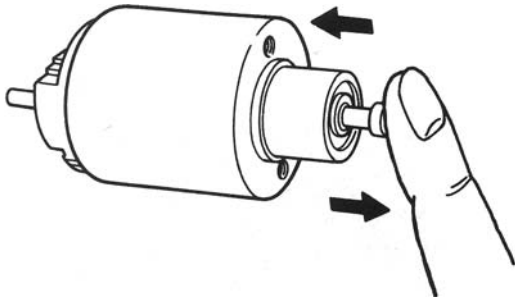


Fig. 925

### Pull-in coil open circuit test

Check for continuity across magnetic switch 'S' terminal and 'M' terminal. If no continuity exists, the coil is open and should be replaced.

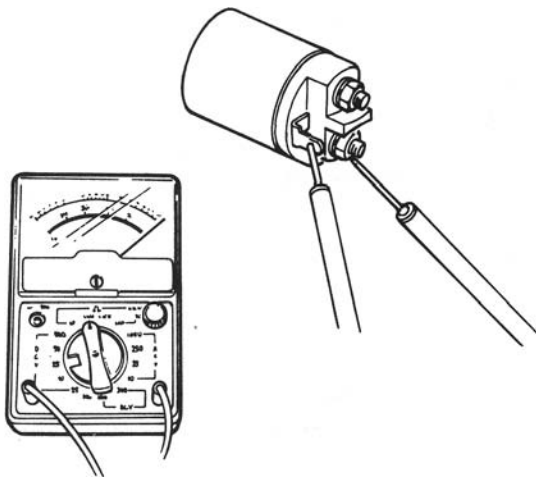


Fig. 926

### Hold in coil open circuit test

Check for continuity across magnetic switch 'S' terminal and coil case. If no continuity exists, the coil is open and should be replaced.

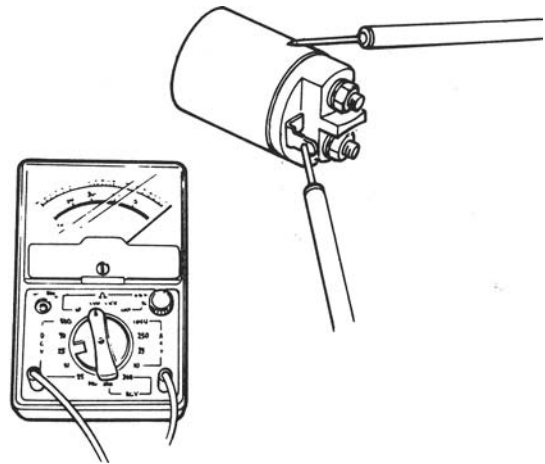
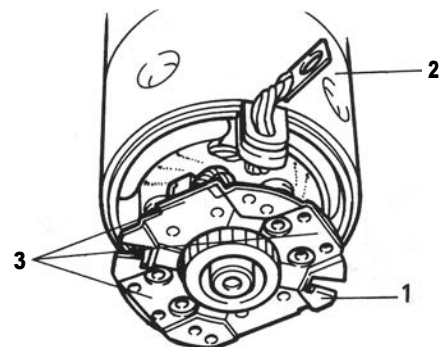


Fig. 927

### REASSEMBLY

Reverse disassembly procedure, using care on following points.

- When installing pinion drive lever, refer to Fig. 9-2 for its installation direction.
- When installing brush holder, be careful of brush position.



- 1. Brush holder
- 2. Yoke

- 3. Brush positions

Fig. 9-27-1

## 9-7. PERFORMANCE TEST

### IMPORTANT:

These tests must be performed within 3 – 5 seconds to avoid burning out the coil.

### 1) Pull-in Test

Connect battery to magnetic switch as shown. Check that plunger moves outward. If plunger does not move, replace magnetic switch.

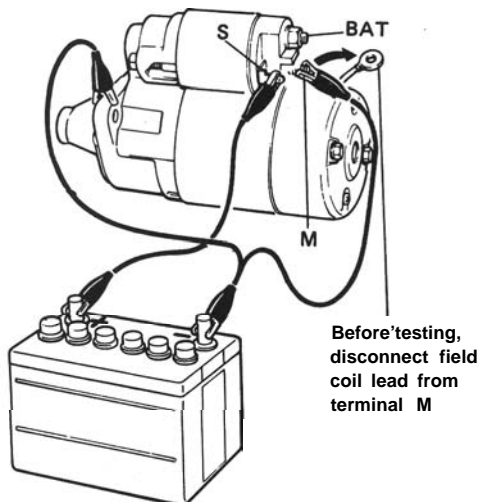


Fig. 9-28

### 2) Hold-in Test

While connected as above with plunger out, disconnect negative lead from terminal M. Check that plunger remains out. If plunger returns inward, replace magnetic switch.

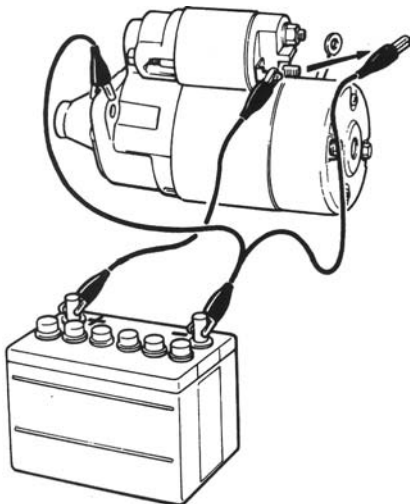


Fig. 9-29

### 3) Check Plunger Return

Disconnect negative lead from switch body. Check that plunger returns inward. If plunger does not return, replace magnetic switch.

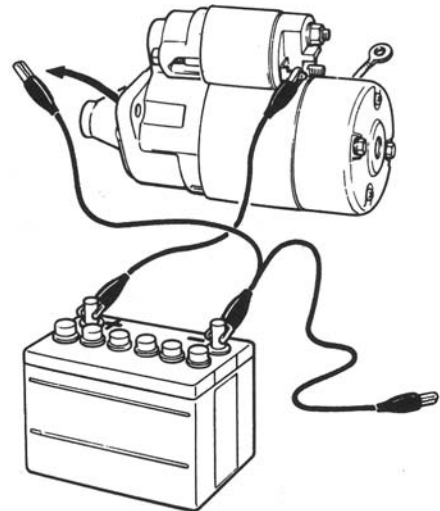


Fig. 9-30

### 4) No-load Performance Test

- Connect battery and ammeter to starter as shown.
- Check that starter rotates smoothly and steadily with pinion moving out. Check that ammeter reads the specified current.

Specified current
Less than 60 A at 11.5 V

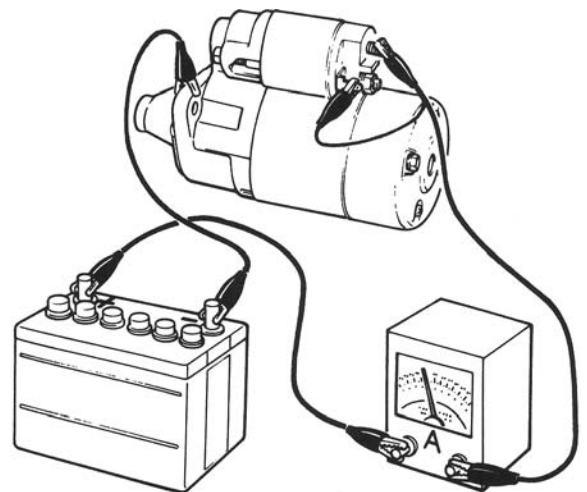


Fig. 9-31

## 9-8. CLUTCH SWITCH

Install clutch switch in such a way that clearance between thread end of clutch switch and clutch pedal (distance 3 in Fig. 9-32) satisfies following specification when clutch pedal is depressed fully.

Tighten clutch switch lock nut to specified torque.

Clutch switch thread end-to-clutch pedal clearance	1.0 – 1.5 mm (0.04– 0.06 in)
--	---------------------------------

Tightening torque for clutch switch lock nut	N·m	kg·m	lb·ft
	10 – 15	1.0 – 1.5	7.5 – 10.5

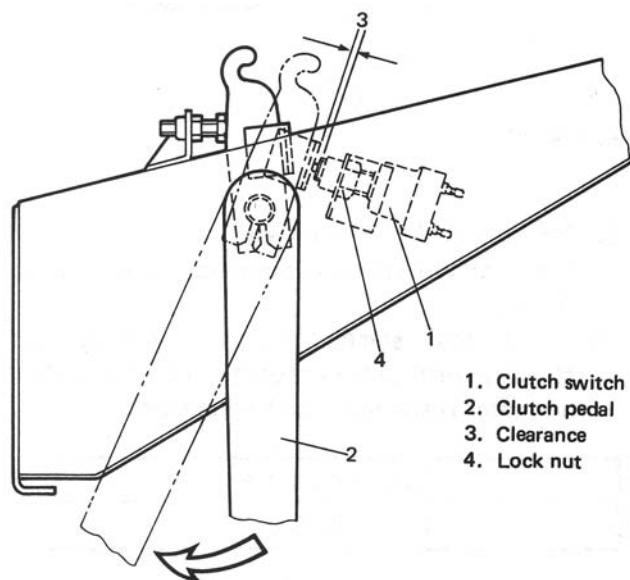


Fig. 9-32



## SECTION 10

# CHARGING SYSTEM

### CONTENTS

<b>10-1. ALTERNATOR</b> .....	<b>10-2</b>
GENERAL DESCRIPTION .....	<b>10-2</b>
DATA AND SPECIFICATION .....	<b>10-3</b>
DIAGNOSIS .....	<b>10-3</b>
REMOVAL .....	<b>10-6</b>
DISASSEMBLY .....	<b>10-6</b>
INSPECTION .....	<b>10-8</b>
ASSEMBLY .....	<b>10-9</b>
<b>10-2. BATTERY</b> .....	<b>10-10</b>
GENERAL DESCRIPTION .....	<b>10-10</b>
CARE OF THE BATTERY .....	<b>10-10</b>
REMOVE AND REPLACE .....	<b>10-12</b>
BATTERY CABLE .....	<b>10-12</b>

# 10-I. ALTERNATOR

## GENERAL DESCRIPTION

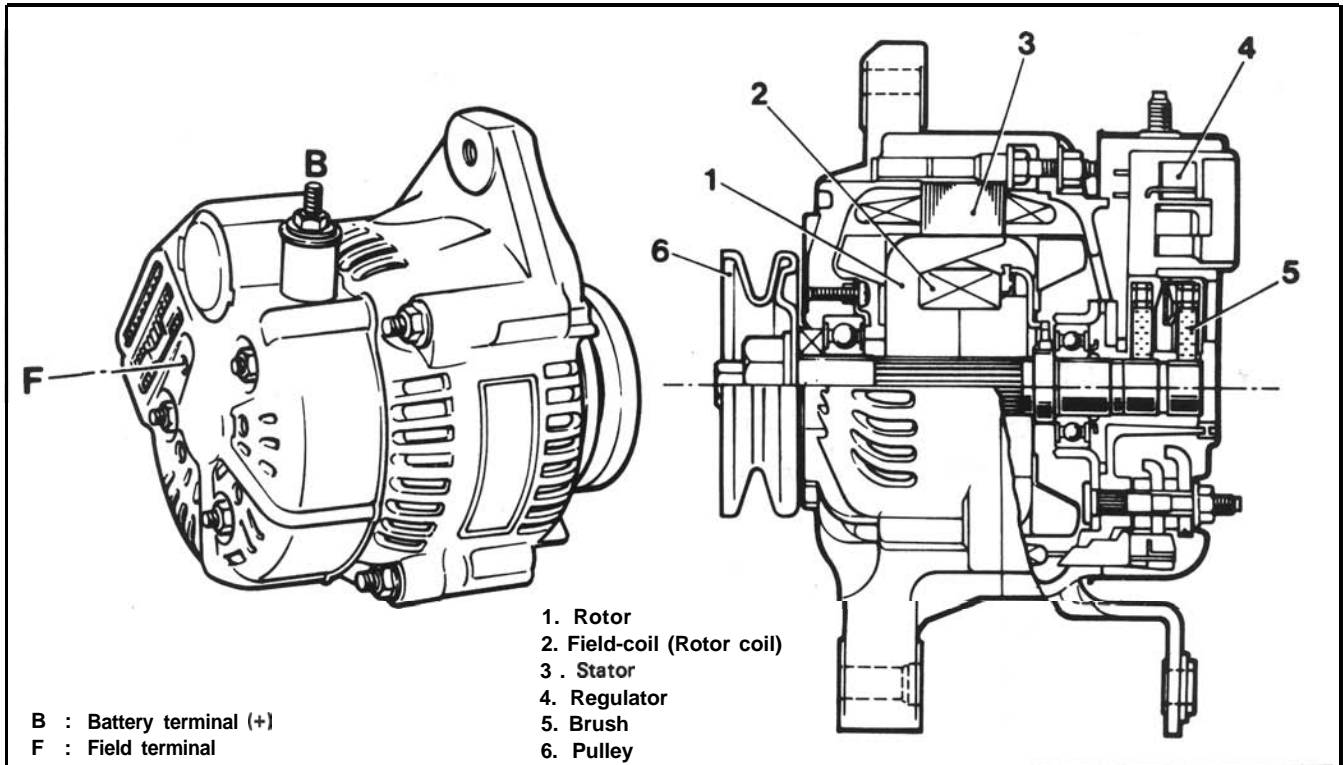


fig. 10-1

The basic charging system is the IC integral regulator charging system. The internal components are connected electrically as shown below,

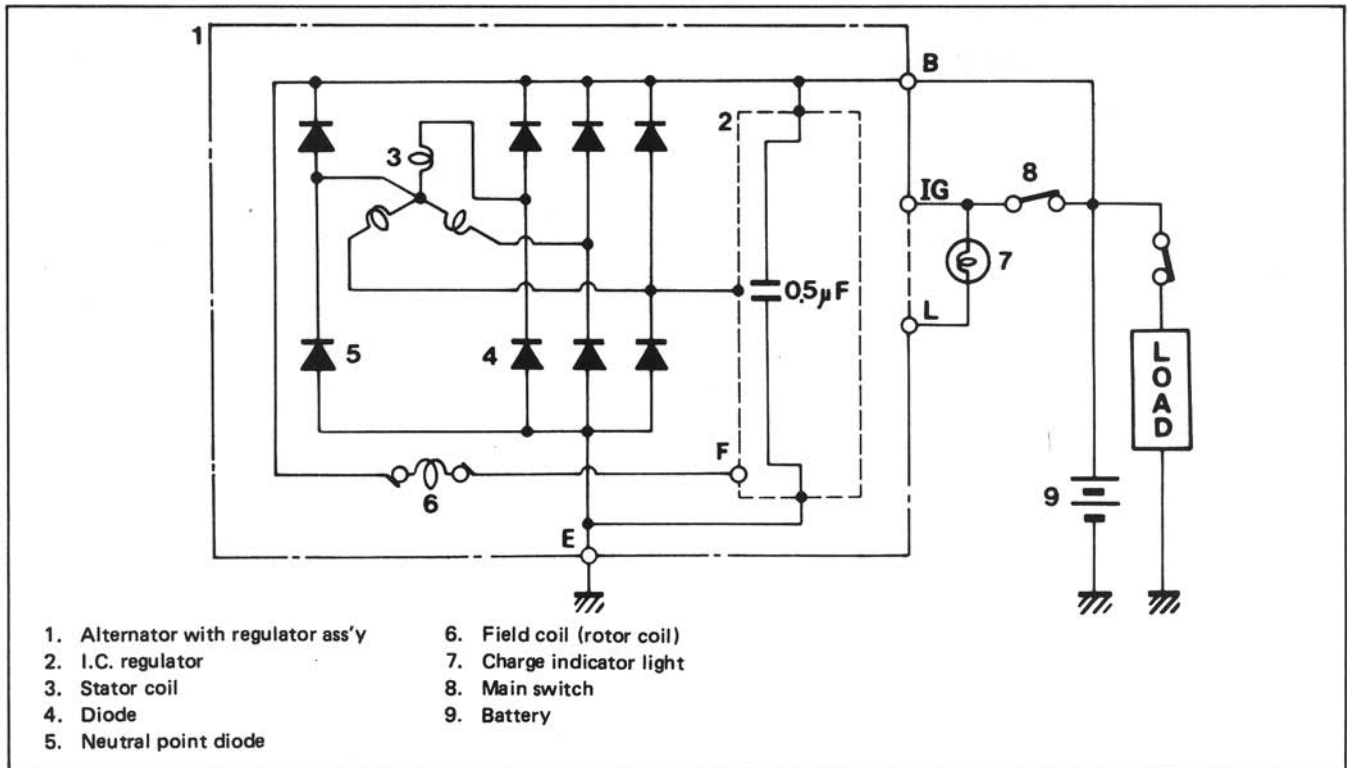


Fig. 10-2

The alternator features a solid state regulator that is mounted inside the alternator. All regulator components are enclosed into a solid mold, and this unit along with the brush holder assembly is attached to the slip ring end frame. The regulator voltage setting cannot be adjusted.

The alternator rotor bearings contain enough grease to eliminate the need for periodic lubrication. Two brushes carry current through the two slip rings to the field coil mounted on the rotor, and under normal conditions will provide long period of attention-free service.

The stator windings are assembled on the inside of a laminated core that forms part of the alternator frame. A rectifier bridge connected to the stator windings contains six diodes, and electrically changes the stator A.C. voltages to a D.C. voltage which appears at the generator output terminal.

The neutral diodes serve to convert the voltage fluctuation at the neutral point to direct current for increasing the alternator output.

A condenser mounted in the end frame protects the diodes from high voltages and suppresses radio noise.

#### DATA AND SPECIFICATION

Nominal operating voltage	12 volts
Max. alternator output	45A
Polarity	Negative ground
No-load alternator speed	1,110 rpm (r/min)
Regulated voltage	14.5 ± 0.3 V
Direction of rotation	Clockwise as viewed from pulley side
Maximum permissible alternator speed	15,000 rpm (r/min)
Working temperature range	-30 ~ 90°C (-22 ~ 194°F)
Rectification	Full wave rectification

#### Noisy Alternator

Noise from the alternator may be caused by a loose drive pulley, loose mounting bolts, worn or dirty bearings, defective diode, or defective stator.

#### DIAGNOSIS

A charging circuit wiring diagram for alternator connection is shown above. To avoid damage, always follow these precautions:

- 1) Do not mistake the polarities of IG terminal and L terminal.
- 2) Do not create short circuit between IG and L terminals. Always connect these terminals through a lamp.
- 3) Do not connect any load between L and E.

Trouble in the charging system will show up as one or more of the following conditions:

- a. Faulty indicator lamp operation.
- b. An undercharged battery as evidenced by slow cranking or indicator clear with red dot.
- c. An overcharged battery as evidenced by excessive spewing of electrolyte from the vents.

### A. Faulty Indicator Lamp Operation

Problem	Possible cause	Correcti on
Charge light does not light with ignition ON and engine off	Fuse blown Light burned out Wiring connection loose IC regulator faulty	Check fuse Replace light Tighten loose connections Replace IC regulator
Charge light does not go out with engine running (battery requires frequent re-charging)	Drive belt loose or worn Battery cables loose, corroded or worn IC regulator or alternator faulty Wiring faulty	Adjust or replace drive belt Repair or replace cables Check charging system Repair wiring

### B. Undercharged Battery

This condition, as shown by slow cranking or indicator clear with red dot, can be caused by one or more of the following conditions even though the indicator lamp may be operating normally. The following procedures also apply to cars with a voltmeter.

- 1) Insure that the undercharged condition has not been caused by accessories left on for extended period.
- 2) Check drive belt for proper tension.
- 3) If a battery defect is suspected, refer to latter part of this section, p. 10-10 ~ p. 10-11.
- 4) Inspect wiring for defects. Check all connections for tightness and cleanliness, including slip connectors at alternator and bulkhead, and battery cable connections at battery, starter and ignition ground cable.
- 5) Connect voltmeter and ammeter as shown in the diagram below.

#### a. Voltmeter

Set between alternator (B) terminal and ground.

#### b. Ammeter

Set between alternator (B) terminal and battery (+) terminal.

#### 6) Current and voltage measurements

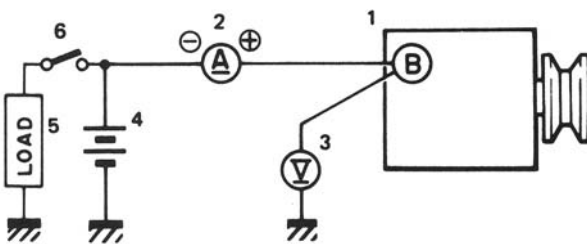
##### a. No-load check

Run engine from idling up to 2,000 r/min (rpm) and read meters.

Standard current	10 A maximum
Standard voltage	14.2 – 14.8 V (at 25° C, 77° F)

#### NOTE:

Consideration should be taken that the voltage will vary somewhat with regulator case temperature.



1. Generator
2. Ammeter
3. Volt meter
4. Battery
5. Load
6. Switch

Fig. 10-3

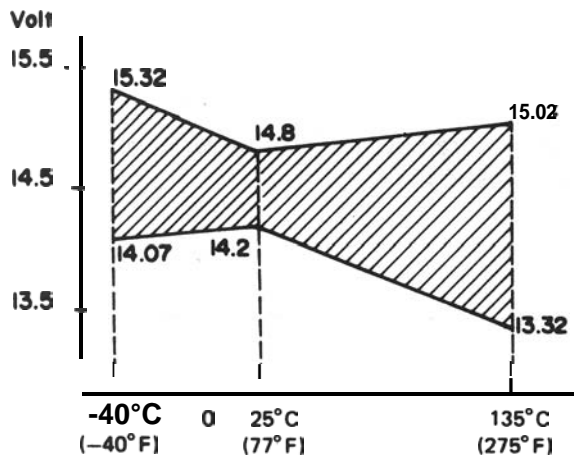


Fig. 10-4

If voltage is higher than standard value, replace IC regulator.

If voltage is below standard value, check IC regulator and alternator as follows:

Ground F terminal and start engine. Then measure voltage at B terminal.

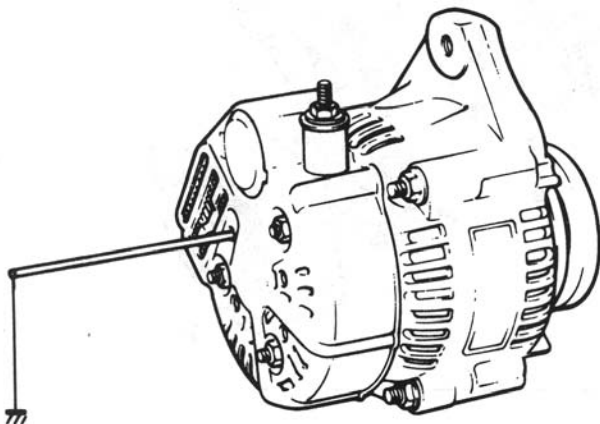


Fig. 10-5 Grounding terminal "F"

If voltage is above standard value, replace IC regulator.

If voltage is below standard value, check alternator.

**b. Load check**

Run engine at 2,000 r/min (rpm) and turn on headlamps and heater motor.

Measure current and if less than 20A, repair alternator.

**C. Overcharged Battery**

- 1) If an obvious overcharge condition exists as evidenced by excessive spewing of electrolyte, proceed to **DISASSEMBLY** under **ALTERNATOR SERVICE** on p.10-6 and check field windings for grounds and shorts. If defective, replace rotor.

## ALTERNATOR SERVICE

### REMOVAL

- 1) Remove battery (-) terminal.
- 2) Disconnect alternator lead wires (coupler & white lead wire).
- 3) Unclamp brake pipe from pipe clamp on radiator under cover and remove radiator under cover.
- 4) Remove alternator mounting bolts and alternator drive belt adjusting bolt.
- 5) Take down alternator.

### DIASSEMBLY

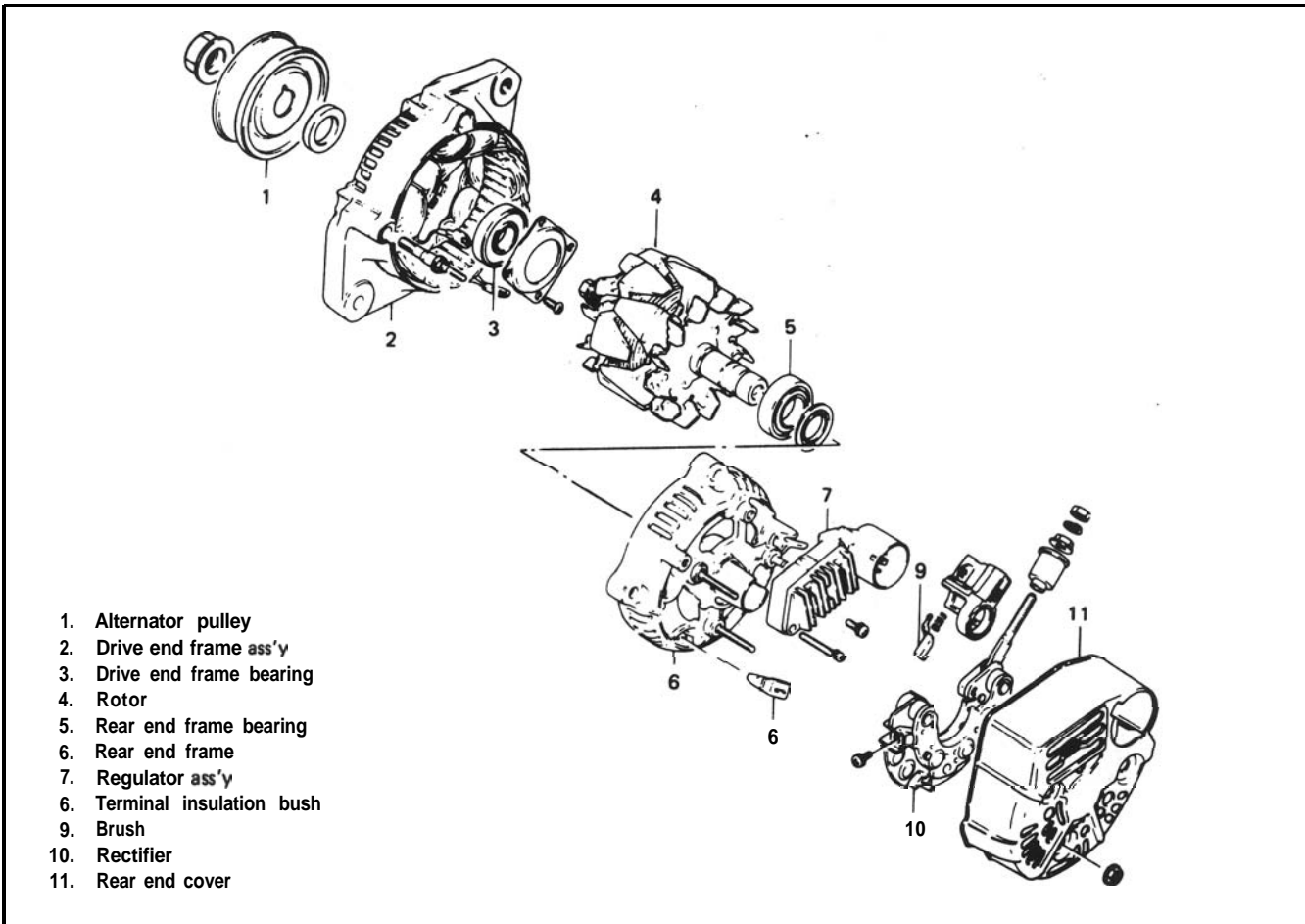


Fig. 10-6

- 1) Remove nut and take off B terminal insulator bushing.
- 2) Remove 3 nuts and take off rear end cover.
- 3) Remove 2 regulator mounting screws and 3 brush holder screws and take off regulator and brush holder.
- 4) Remove 4 stator coil terminal screws.
- 5) Remove rectifier holder together with I.C. regulator.
- 6) Remove 4 nuts and take off rear end frame,

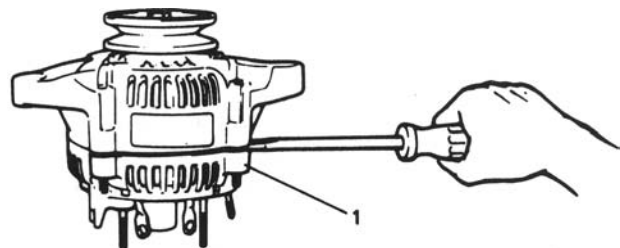
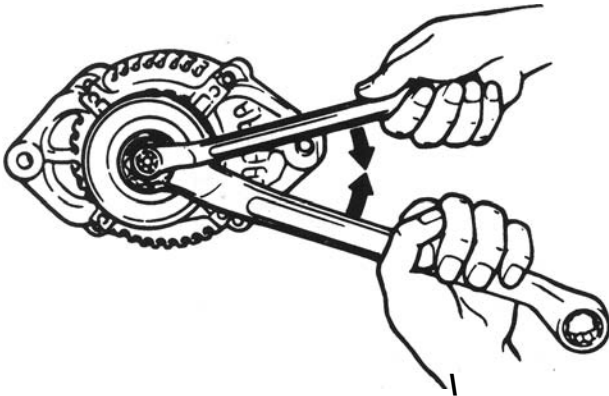


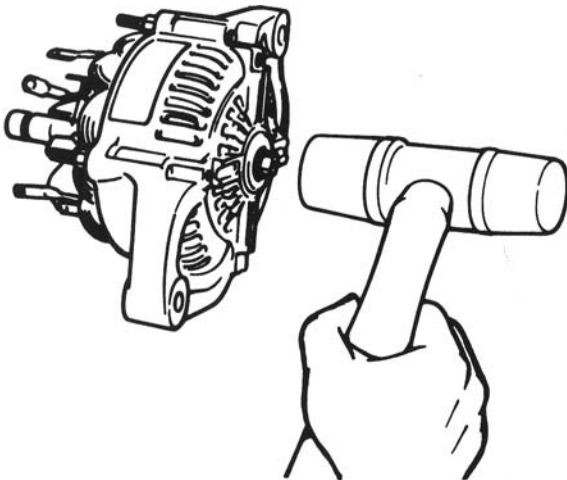
Fig. 10-7

7) Loosen alternator pulley nut and take off pulley.



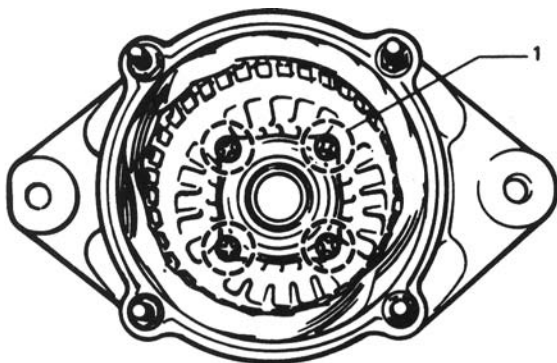
**Fig. 108**

8) Remove rotor from drive end frame.



**Fig. 109**

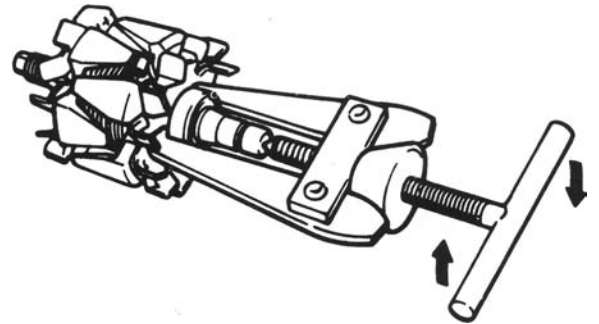
9) When removing front end bearing, remove 4 4-mm bearing retainer screws.



1. Bearing retainer fitting screw

**Fig. 1010**

10) When removing rear bearing, use bearing puller.



**Fig. 10- 11**

## INSPECTION

### Rotor

- 1) Check rotor for no open circuits  
Using an ohmmeter, check for continuity between slip rings.

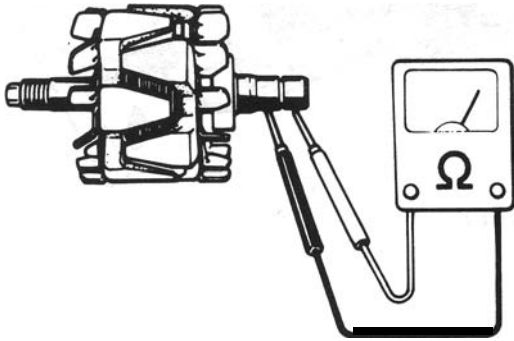


Fig. 10-12

Standard resistance	2.8 – 3.0 $\Omega$
---------------------	--------------------

If there is no continuity, replace rotor.

- 2) Check rotor for no grounds.  
Using an ohmmeter, check that there is no continuity between slip ring and rotor.  
If there is continuity, replace rotor.

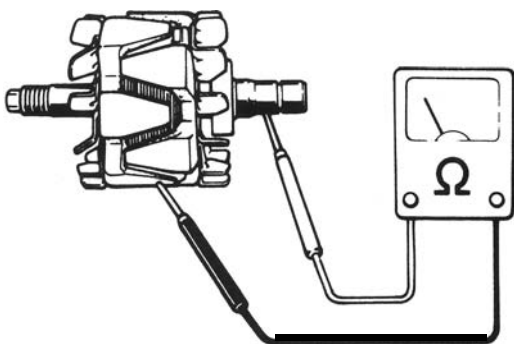


Fig. 10-13

- 3) Inspect slip rings  
Check slip rings for roughness or scoring. If rough or scored, replace rotor.

### Stator

- 1) Check stator for no open circuits  
Using an ohmmeter, check all leads for continuity. If there is no continuity, replace stator.

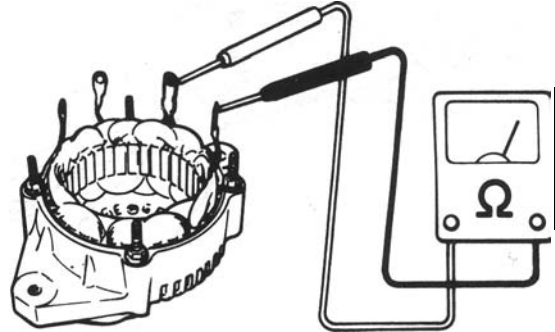


Fig. 1014

- 2) Check stator for no grounds  
Using an ohmmeter, check that there is no continuity between coil leads and stator core.  
If there is continuity, replace rotor.

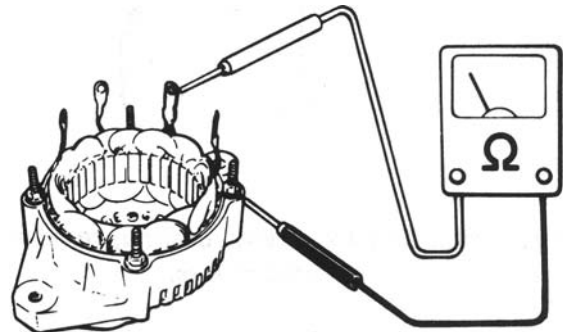


Fig. 1015



**Brush and Brush holder**

Check each brush for wear by measuring its length as shown. If brush is found worn down to service limit, replace brush with holder.

Brush length	Standard	Service limit
	11 mm (0.43 in)	5 mm (0.20 in)

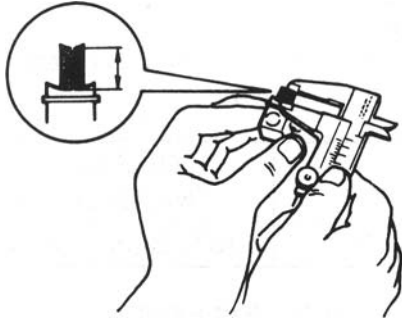


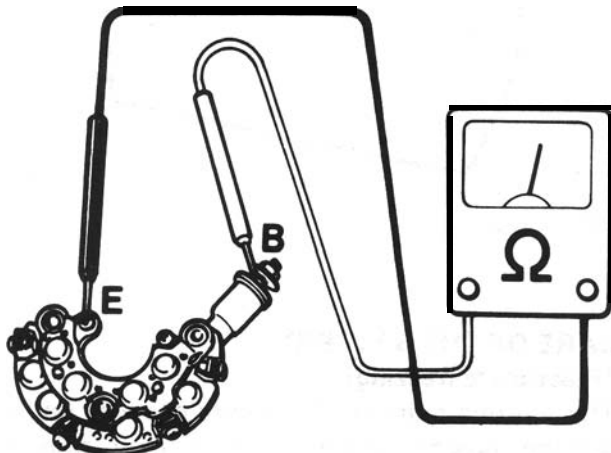
Fig. 10-16

**Rectifier**

Using an ohmmeter, check continuity between "B" terminal and ground.

Put one tester lead to terminal "B" and the other lead to ground; then swap two leads. Of two tester indications, one should be about 10 ohms, meaning continuity, and the other should be infinity (non continuity).

If not, replace rectifier assembly.



B : Battery terminal  
E : Earth

Fig. 10-17

**Condenser**

Check condenser capacity in regulator.

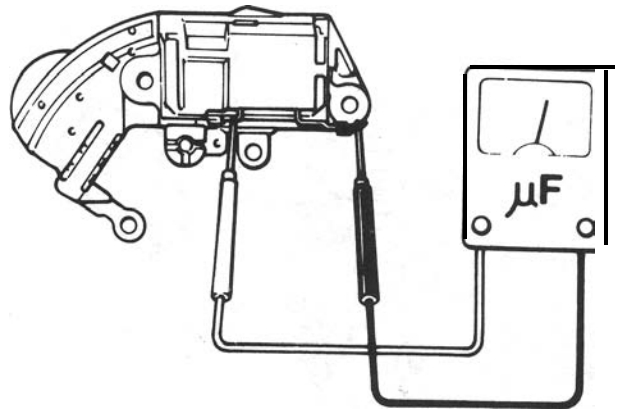


Fig. 10-18

Condenser capacity	0.5 µF
--------------------	--------

**ASSEMBLY**

Reverse disassembly procedure, using care on following points.

- 1) Use a press when forcing bearing into rotor shaft or drive end frame.

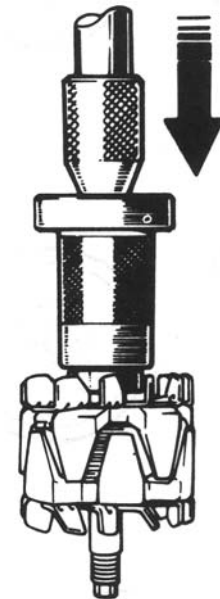
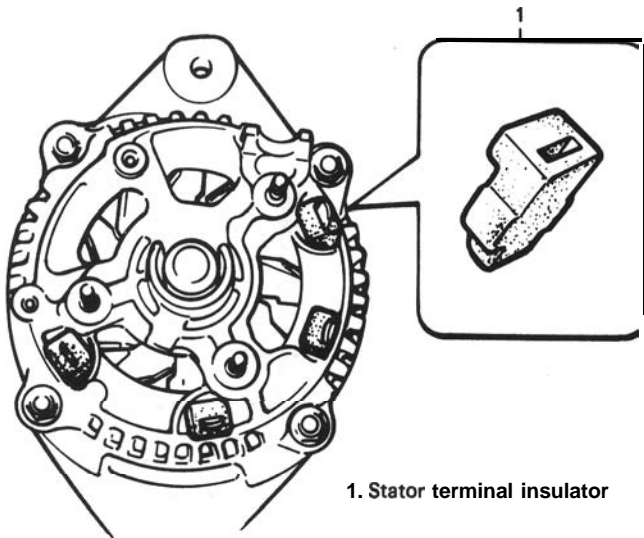


Fig. 10-19

- 2) Alternator pulley tightening torque.

Tightening torque		
50-65 N·m	5.0 – 6.5 kpm	37 - 47 lb-ft

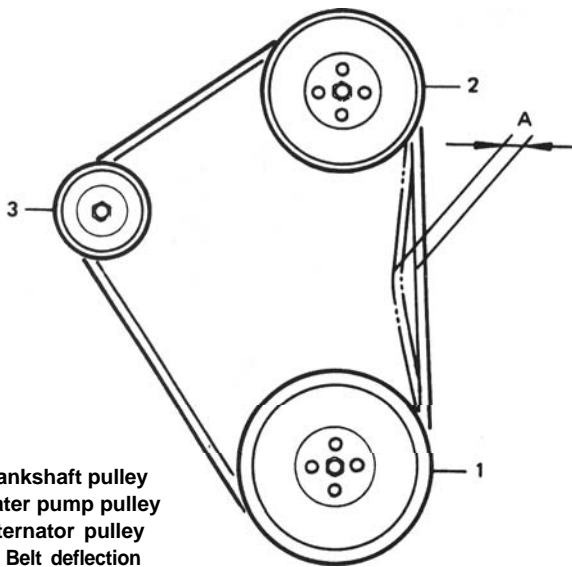
3) Make sure to assemble stator terminal insulator properly.



1. Stator terminal insulator

Fig. 10-20

4) Alternator V belt tension.



- 1. Crankshaft pulley
- 2. Water pump pulley
- 3. Alternator pulley
- A : Belt deflection

Fig. 10-21

Drive belt deflection (Under 10 kg thumb pressure)	6 – 9 mm (0.24 – 0.35 in)
---	------------------------------

**NOTE:**

Clamp brake pipe with pipe clamp on radiator under cover after installing radiator under cover.

## 10-2. BATTERY

### GENERAL DESCRIPTION

The battery has three major functions in the electrical system. First, it is a source of electrical energy for cranking the engine. Second it acts as a voltage stabilizer for the electrical system. And third, it can, for a limited time, provide energy when the electrical load exceeds the output of the generator.

Each new car shipped from the factory is fitted with following battery.

Model	55B24R (S) (NX100-S6 (S))
Rated capacity	1 3 7 kC (38 Ah)/5HR

This battery is completely sealed, except for six small vent holes in the top. These vent holes allows the small amount of gas produced in the battery to escape. This sealed battery has a built-in temperature compensated indicator in the top of the battery.

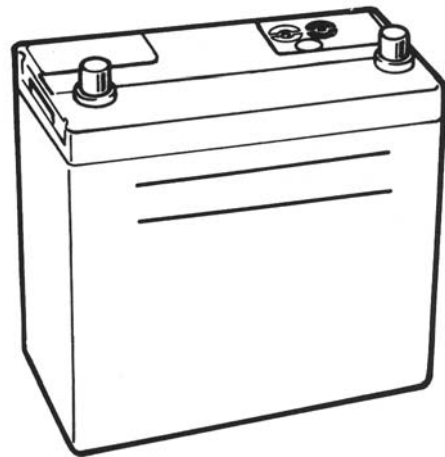


Fig. 10-22

### CARE OF THE BATTERY

#### [Electrolyte freezing]

The freezing point of electrolyte depends on its specific gravity. Since freezing may ruin a battery, it should be protected against freezing by keeping it in a fully charged condition.

**[Carrier and hold-down]**

The battery carrier and hold-down clamp should be clean and free from corrosion before installing the battery. The carrier should be in good condition so that it will support the battery securely and keep it level.

Make certain there are no parts in carrier before installing the battery.

To prevent the battery from shaking in its carrier, the hold-down bolts should be tight but not over tightened.

**[Visual inspection]**

Check for obvious damage, such as cracked or broken case or cover, that could permit loss of electrolyte. If obvious damage is noted, replace the battery. Determine cause of damage and correct as needed.

Check the battery terminal and cords for corrosion. If any, it should be cleaned.

**[Built-in indicator]**

This sealed battery has a built-in temperature compensated indicator in the top of the battery. This indicator is to be used with the following diagnostic procedure. When observing the indicator, make sure that the battery has a clean top. A light may be needed in some poorly-lit areas.

Under normal operation, two indications can be seen



1		OK
2		CHARGING NECESSARY

Fig. 10-23

- **Clear with Red Dot**

This means the discharging battery. In this case, charge the battery until the indicator will be blue with red dot. The charging and electrical systems should also be checked at this time. If any defective is found, correct it. While charging it, if the battery feels hot 52°C (125° F), or if violent gassing or spewing of electrolyte through the vent hole occurs, discontinue charging or reduce charging rate.

[Jump starting in case of emergency with auxiliary (booster) battery]

**NOTE:**

- Do not push or tow the vehicle to start. Damage to the emission system and/or to other parts of the vehicle may result.
- Both booster and discharged battery should be treated carefully when using jumper cables. Follow the procedure outlined below, being careful not to cause sparks:

**CAUTION:**

- Departure from these conditions or the procedure below could result in: (1) Serious personal injury (particularly to eyes) or property damage from such causes as battery explosion, battery acid, or electrical burns; and/or (2) damage to electronic components of either vehicle.
- Never expose battery to open flame or electric spark-batteries generate a gas which is flammable and explosive.
- Remove rings, watches, and other jewelry. Wear approved eye protection.
- Do not allow battery fluid to contact eyes, skin, fabrics, or painted surfaces - fluid is a corrosive acid. Flush any contacted area with water immediately and thoroughly. Be careful that metal tools or jumper cables do not contact the positive battery terminal (or metal in contact with it) and any other metal on the car, because a short circuit could occur. Batteries should always be kept out of the reach of children.

- 1) Set parking brake and place transmission in neutral. Turn off the ignition, turn off lights and all other electrical loads.
- 2) Check electrolyte level. If level is below low level line, replace battery.

**NOTE:**

When jump starting an engine with charging equipment, be sure equipment used is 12-volt and negative ground. Do not use 24-volt charging equipment. Using each equipment can cause serious damage to the electrical system or electronic parts.

- 3) Attach the end of one jumper cable to the positive terminal of the booster battery and the other end of the same cable to the positive terminal of the discharged battery. Do not permit vehicles to touch each other as this could cause a ground connection and counteract the benefits of this procedure. (Use 12-volt battery only to jump start the engine).
- 4) Attach one end of the remaining negative cable to the negative terminal of the booster battery, and the other end to a solid engine ground (such as A/C compressor bracket or generator mounting bracket) at least 18 inches from the battery of the vehicle being started (DO NOT CONNECT DIRECTLY TO THE NEGATIVE TERMINAL OF THE DEAD BATTERY).
- 5) Start the engine of the vehicle that is providing the jump start and turn off electrical accessories. Then start the engine in the car with the discharged battery.
- 6) Reverse these directions exactly when removing the jumper cables. The negative cable must be disconnected from the engine that was jump started first.

## REMOVE AND REPLACE

When handling a battery, the following safety precautions should be followed:

- 1) Hydrogen gas is produced by the battery. A flame or spark near the battery may cause the gas to ignite.
- 2) Battery fluid is highly acidic. Avoid spilling on clothing or other fabric. Any spilled electrolyte should be flushed with large quantity of water and cleaned immediately. To remove or replace a battery, always disconnect the negative cable first, then the positive cable.

## BATTERY CABLES

Connect battery cables as shown in the figure below and make sure to properly tighten all terminals.

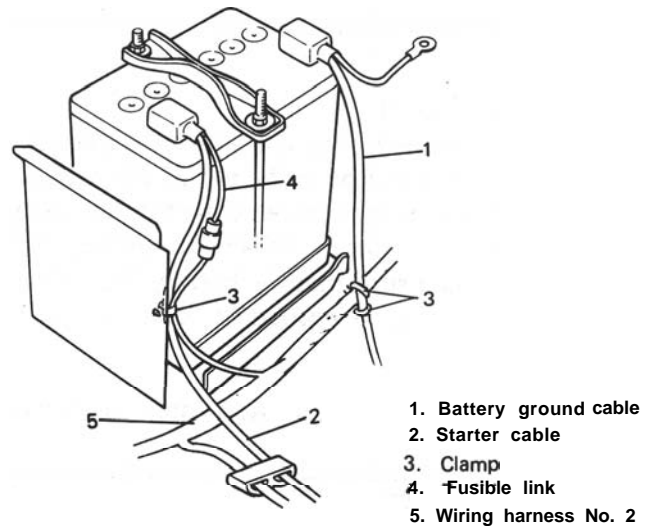


Fig. 10-24

## SECTION 11

# CLUTCH

### CONTENTS

11-1. GENERAL DESCRIPTION .....	11-2
11-2. REMOVAL .....	11-2
11-3. INSPECTION OF COMPONENTS.....	11-5
11-4 INSTALLATION .....	11-7
11-5. MAINTENANCE SERVICES .....	11-8
11-6 RECOMMENDED TORQUE SPECIFICATION .....	11-10

## 11-I. GENERAL DESCRIPTION

The clutch is a diaphragm-spring clutch of a dry single disc type. The diaphragm spring is of a tapering-finger type, which is a solid ring in the outer diameter part, with a series of tapering fingers pointing inward. The disc, carrying four torsional coil springs, is slidably mounted on the transmission input shaft with a serration fit.

The clutch cover is secured to the flywheel, and carries the diaphragm spring in such a way that the peripheral edge of the spring pushes on the pressure plate against the flywheel (with the disc in between), when the clutch release bearing is held back: This is the engaged condition of the clutch.

Depressing the clutch pedal causes the release bearing to advance and push on the tips of the tapering fingers of the diaphragm spring. When this happens, the diaphragm spring pulls the pressure plate away from the flywheel, thereby interrupting the flow of drive from flywheel through clutch disc to transmission input shaft.

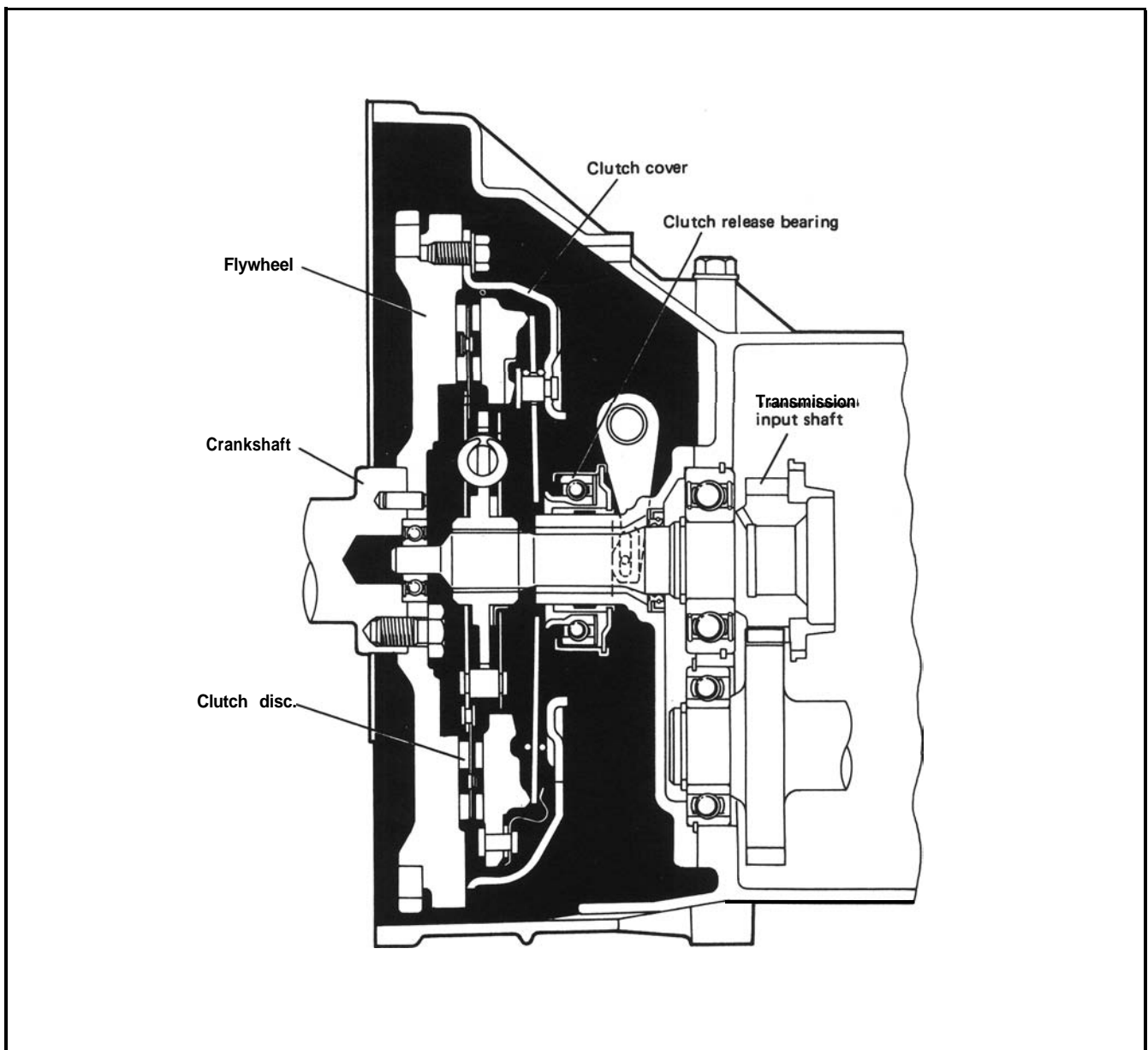
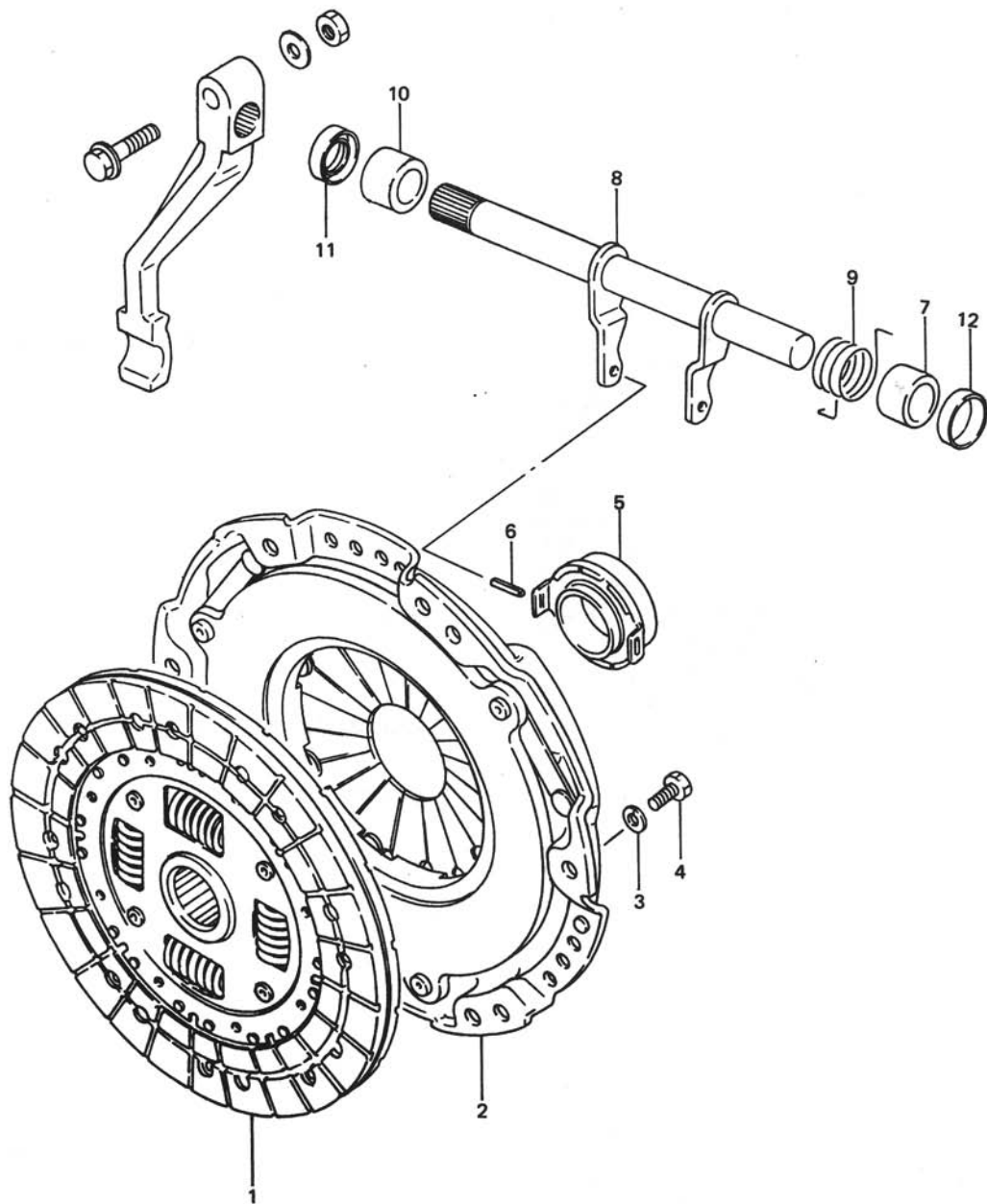


Fig. 11-1



- |                            |                         |
|----------------------------|-------------------------|
| 1. Clutch disc             | 7. No. 2 bushing        |
| 2. Clutch cover            | 8. Clutch release shaft |
| 3. Lock washer             | 9. Return spring        |
| 4. Cover bolt              | 10. No. 1 bushing       |
| 5. Clutch release bearing  | 11. Shaft seal          |
| 8. Clutch release fork pin | 12. Shaft cover         |

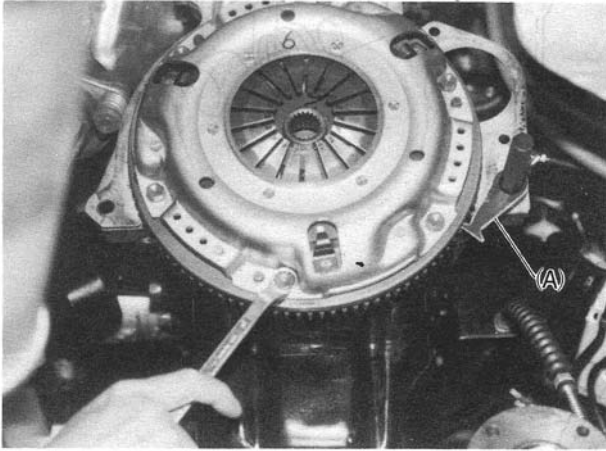
Fig. 11-2

## 11-2. REMOVAL

Removal of clutch presupposes that the transmission has been dismantled according to the method outlined in SECTION 13 TRANSMISSION.

### Clutch Cover and Disc

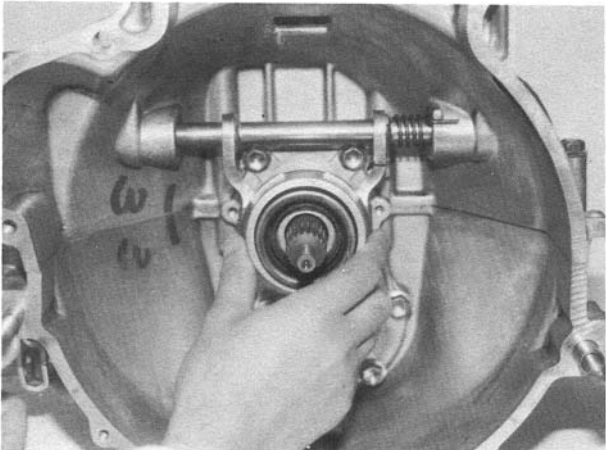
Remove 6 bolts securing clutch cover to flywheel, and take off clutch cover and disc.



**Fig. 11-3** Ⓐ Special tool (Flywheel holder 09924-17810)

### Clutch Release Bearing

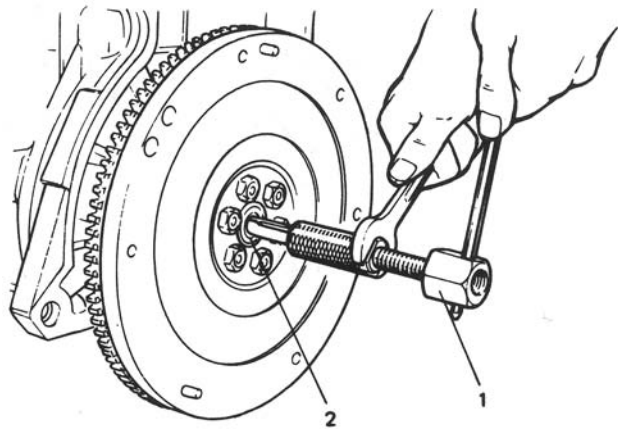
Remove clutch release bearing from transmission input shaft bearing retainer.



**Fig. 11-4**

### Input Shaft End Bearing

Use bearing remover (special tool) for removal of this bearing.



1. Special tool (Bearing remover 09917-58010)
2. Input shaft bearing

**Fig. 11-5**

### Clutch Release Shaft Bushes

For replacement of bushes, refer to p. 13-5 of SECTION 13 TRANSMISSION.



### 11-3. INSPECTION OF COMPONENTS

#### Clutch Disc Facing Surface Condition

A burnt or glazed (glass-like surface) facing can be reconditioned by grinding it with No. 120 – 200 sandpaper. If surface is in bad condition beyond repair, replace whole clutch disc assembly.

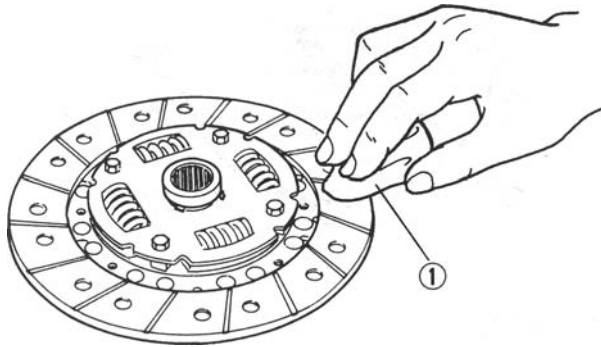


Fig. 1 I-6 ① Sandpaper

#### Clutch Facing Wear

Check wear of facing by measuring depth of each rivet head depression, i.e. distance between rivet head and facing surface. If depressing is found to have reached service limit at any of the holes, replace clutch disc assembly.

Rivet head depression	Standard	Service limit
	1.2 mm (0.05 in.)	0.5 mm (0.02 in.)

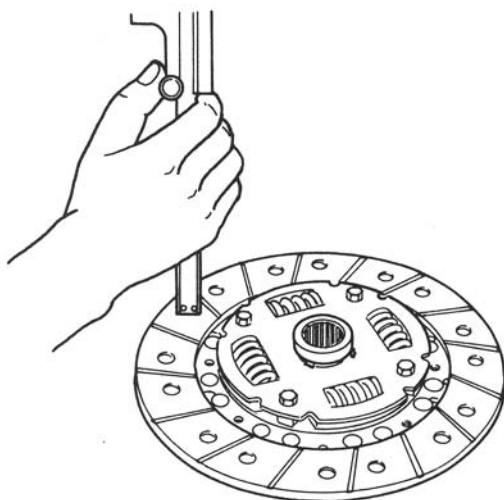


Fig. 11-7

#### Backlash in Disc Serration Fit

Check backlash by turning disc back and forth as mounted on transmission input shaft. Replace disc assembly if backlash is noted to exceed service limit. Backlash here is a circular displacement as measured with a dial indicator.

Backlash in serration fit	Service limit
	0.8 mm (0.03 in.)

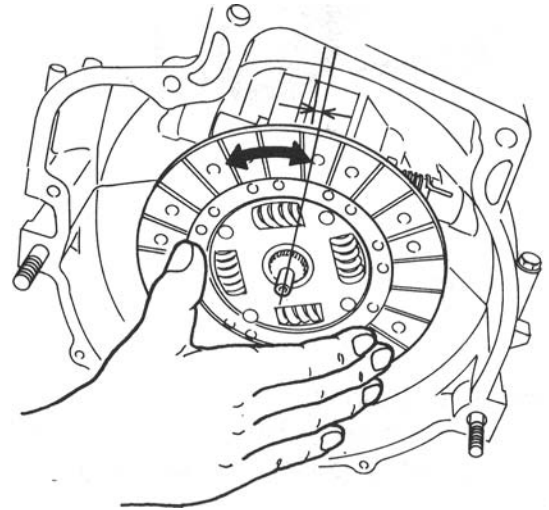


Fig. 11-8

#### Clutch Cover

Inspect clutch cover for evidence of diaphragm spring rivets getting loose. If rivets are loose or are getting loose, replace cover assembly as such cover makes rattling noise when clutch pedal is depressed.

Inspect tips of tapering fingers (to which the release bearing exerts a push to disengage clutch) for wear. If tips are worn excessively, replace cover assembly.

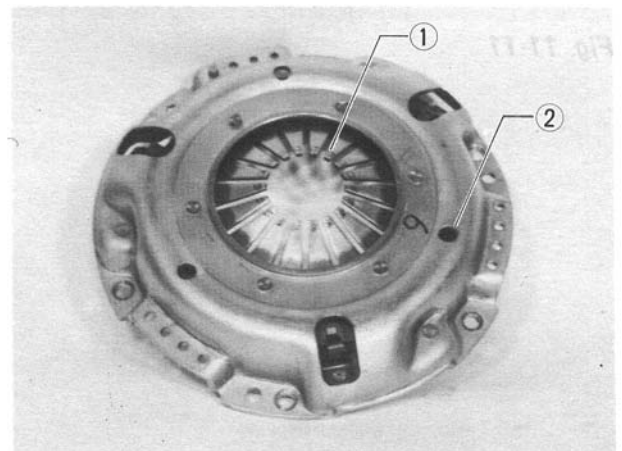


Fig. 11-9 ① Spring rivet; ② Rivet

### Release Bearing

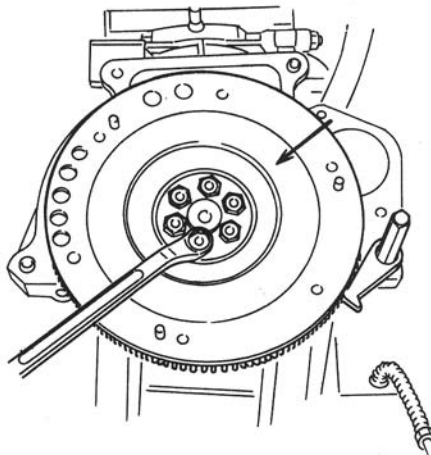
Replace release bearing if it sticks, rattles or makes abnormal noise when spun and turned by hand.



**Fig. 11-10**

### Flywheel

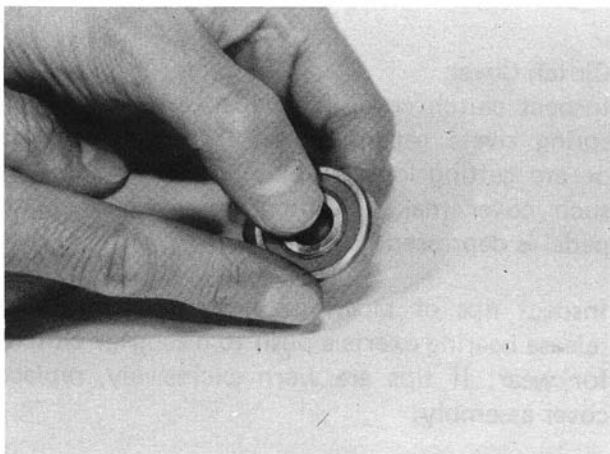
Check surface contacting clutch disc for any wear or damage.



**Fig. 11-12**

### Input Shaft Bearing

Replace input shaft bearing if it sticks, rattles or makes abnormal noise when spun and turned by hand.



**Fig. 11- 11**

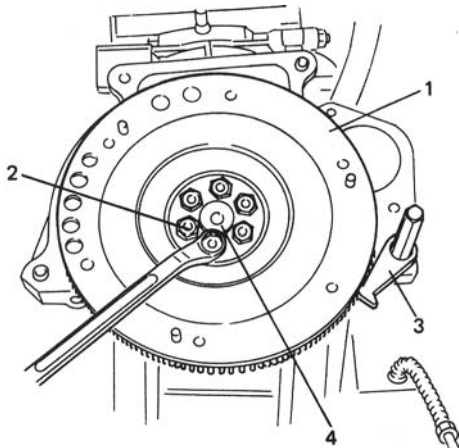
## 114. INSTALLATION

Install clutch by reversing removal procedure. Some important steps will be explained below.

### Flywheel

1) Tighten bolts to specification.

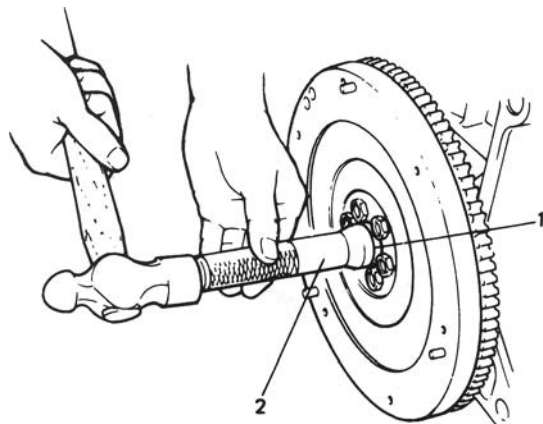
Tightening torque for flywheel bolts	N·m	kg·m	lb·ft
	57 – 65	5.7 – 6.5	41.5 – 47.0



1. Flywheel
2. Flywheel bolt
3. Special tool (Flywheel holder 09924-I 7810)
4. Input shaft bearing

Fig. 11-13

2) Install input shaft end bearing to flywheel using bearing installer (special tool).



1. Input shaft bearing
2. Special tool (Input shaft bearing installer 09925-98210)

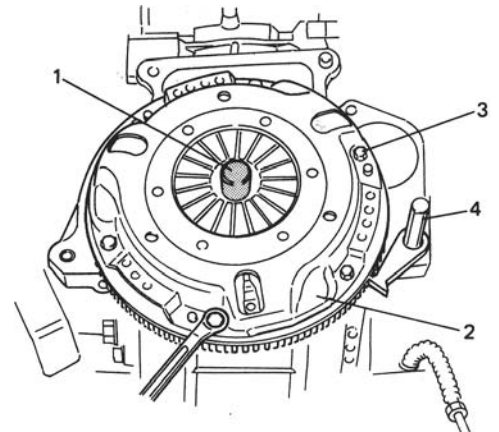
Fig. 11-13-1

### Clutch Disc and Clutch Cover

Using special tool (clutch center guide), install clutch disc and clutch cover.

Tighten clutch cover bolts to specification using special tool (Flywheel holder).

Tightening torque for clutch cover bolts	N·m	kg·m	lb·ft
	18 – 28	1.8 – 2.8	13.5 – 20.0



1. Special tool (Clutch center guide 09923-38220)
2. Clutch cover
3. Clutch cover bolt
4. Special tool (Flywheel holder 09924-I 7810)

Fig. 11-14

### Clutch Release Bearing

Before installing retainer, apply grease to its inner surface.

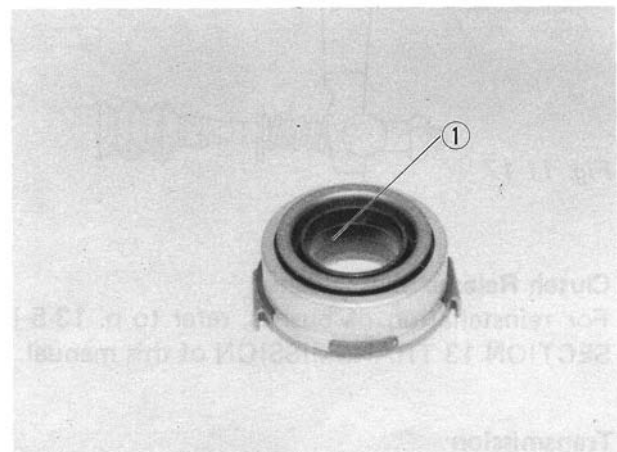


Fig. 11-15 ① Grease (SUZUKI SUPER GREASE "A")

**Clutch Release Shaft Fork**  
Apply grease to end of fork.

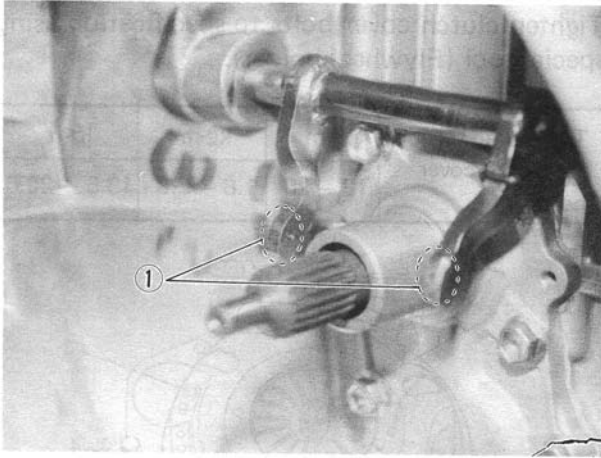


Fig. 11- 16 ① Grease (SUZUKI SUPER GREASE "A")

**Clutch Release Arm**  
Align two punch marks when installing clutch release arm on clutch release shaft.

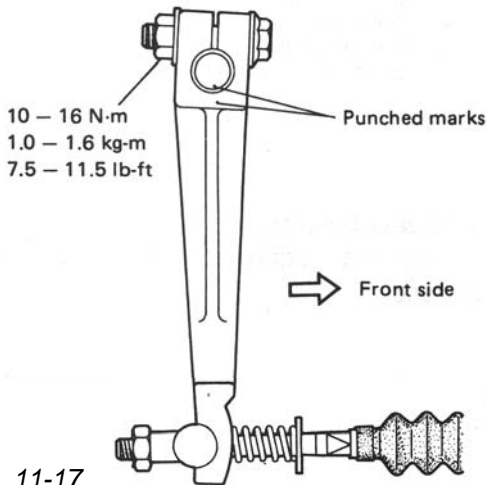


Fig. 11-17

**Clutch Release Shaft Bushes**  
For reinstallation of bushes, refer to p. 13-5 in SECTION 13 TRANSMISSION of this manual.

**Transmission**  
For remounting transmission, refer to p. 13-4 in SECTION 13 TRANSMISSION of this manual and reverse dismounting procedure.

Before remounting transmission ass'y, apply grease (SUZUKI SUPER GREASE I) to input shaft. Refer to Fig. 13-84.

## 11-5. MAINTENANCE SERVICES

### Clutch Pedal Height

Adjust height of clutch pedal with clutch pedal stop bolt so that pedal is level with brake pedal. Tighten lock nut after adjusting.

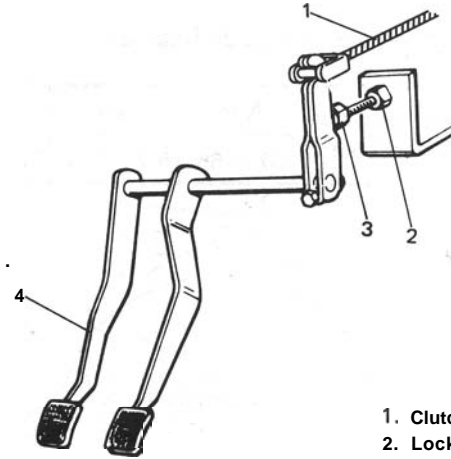


Fig. 11- 18

1. Clutch cable
2. Lock nut
3. Adjust bolt
4. Clutch pedal

### Clutch Pedal Free Travel

1) Depress clutch pedal, stop the moment clutch resistance is felt, and measure distance (clutch pedal free travel). Free travel should be within the following specification.

Clutch pedal free travel	20 - 30 mm (0.8 - 1.1 in.)
--------------------------	-------------------------------

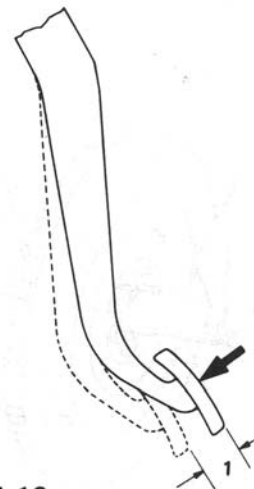


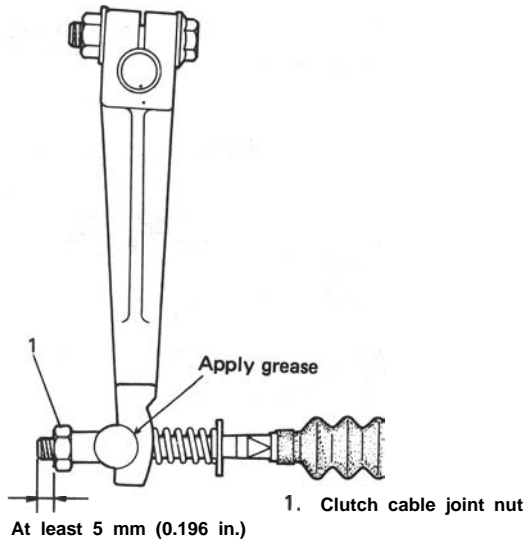
Fig. 11-19

1. Clutch pedal free travel

2) If free travel is out of specification, adjust it with clutch cable outer nuts.

**NOTE:**

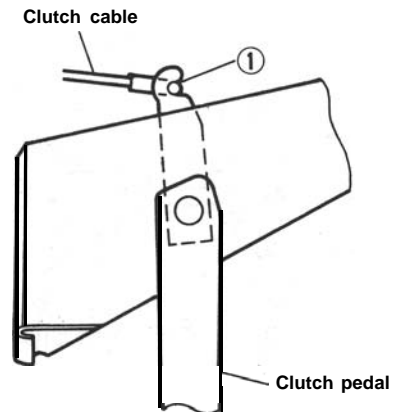
After adjusting free travel, make sure that the clutch cable end protrudes at least 5 mm from joint nut



**Fig. 11-20**

**Clutch Cable Lubrication**

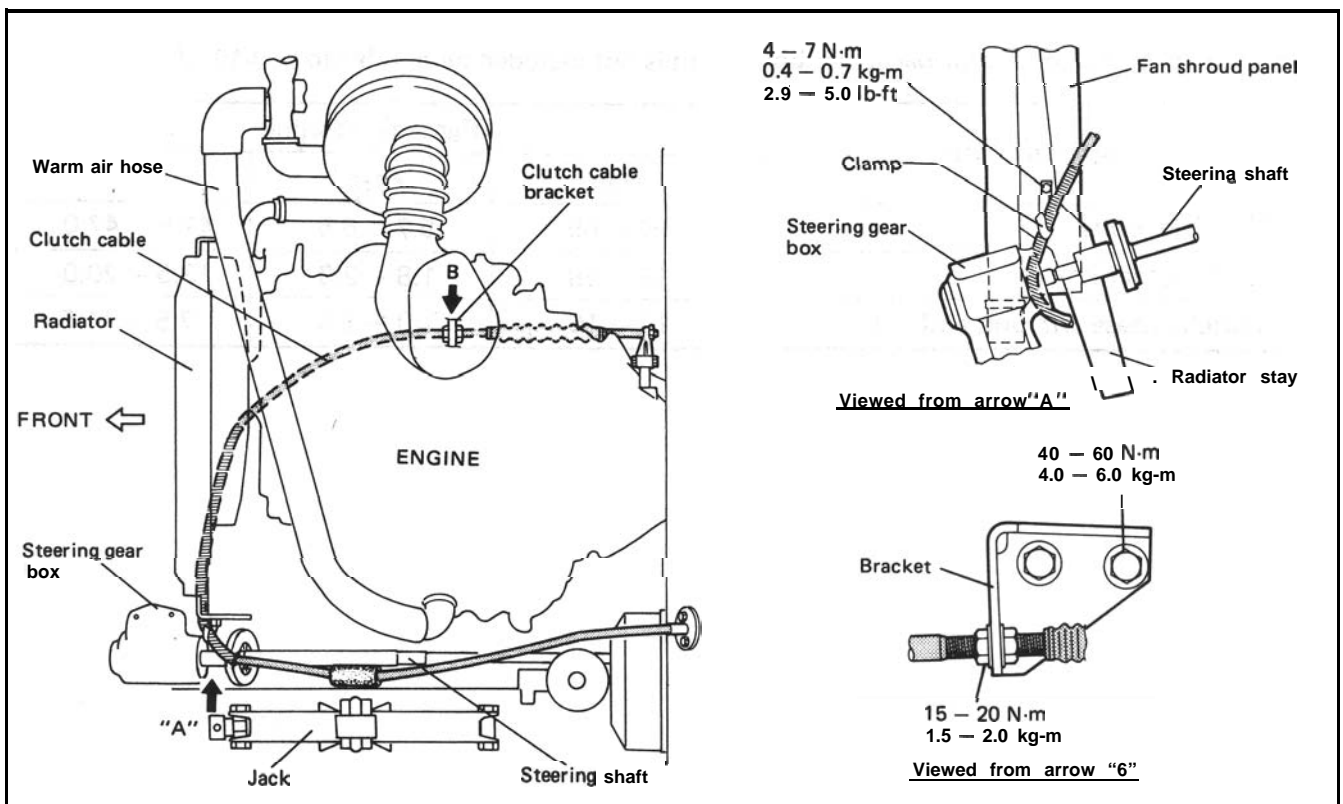
Apply grease to hook part ① of clutch cable.



**Fig. 11-21**

**Clutch Cable Routing**

1) For left-hand side steering vehicle.



**Fig. 1 I-22**

2) For right-hand side steering vehicle.

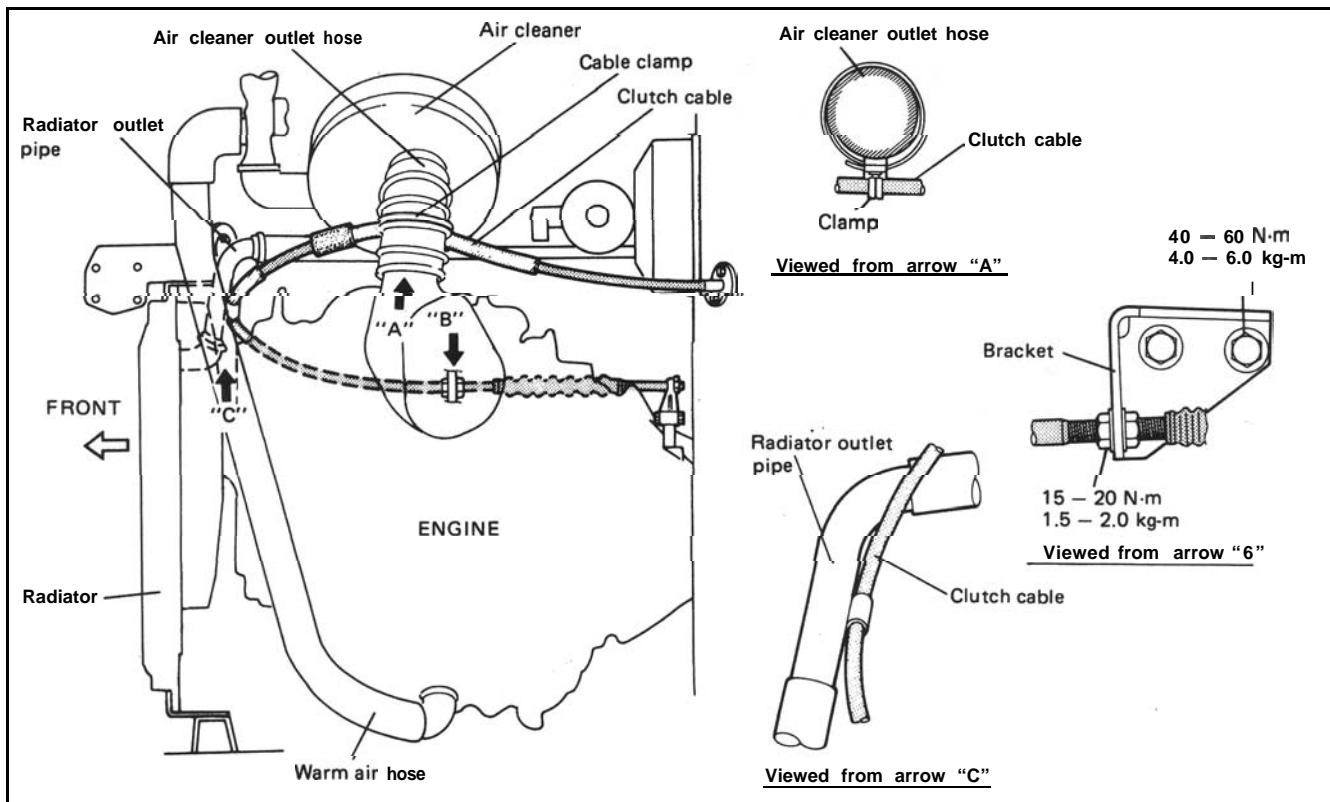


Fig. 11-23

**11-6. RECOMMENDED TORQUE SPECIFICATION**

Be sure to torque each nut or bolt, if loosened, to specification given below.

If specified tightening torque for particular bolt or nut is not included here, refer to p. O-12 of this manual.

Fastening Parts	Tightening torque		
	, N·m	kg-m	lb-ft
1. Flywheel bolts	57 – 65	5.7 – 6.5	41.5 – 47.0
2. Clutch cover bolts	18 – 28	1.8 – 2.6	13.5 – 20.0
3. Clutch release arm bolt and nut	10 – 16	1.0 – 1.6	7.5 – 11.5

## SECTION 12

# GEAR SHIFTING CONTROL

### CONTENTS

<b>12-1. GENERAL DESCRIPTION</b> .....	<b>12-2</b>
<b>12-2. REMOVAL</b> .....	<b>12-3</b>
<b>GEAR SHIFT LEVER</b> .....	<b>12-3</b>
<b>GEAR SHIFT LEVER SELECT GUIDE PINS</b> .....	<b>12-3</b>
<b>12-3. INSPECTION OF COMPONENTS</b> .....	<b>12-4</b>
<b>GEAR SHIFT LEVER</b> .....	<b>12-4</b>
<b>REVERSE &amp; LOW SPEED SELECT GUIDE PINS</b> .....	<b>12-4</b>
<b>GEAR SHIFT FORK SHAFT</b> .....	<b>12-4</b>
<b>12-4. INSTALLATION</b> .....	<b>12-5</b>
<b>REVERSE &amp; LOW SPEED GUIDE PINS</b> .....	<b>12-5</b>
<b>GEAR SHIFT LEVER CASE</b> .....	<b>12-5</b>
<b>GEAR SHIFT CONTROL LEVER SEAT</b> . . . . .	<b>12-6</b>
<b>TIGHTENING TORQUE &amp; GREASING POINT</b> .....	<b>12-6</b>

## 12-1. GENERAL DESCRIPTION

In this gear shifting control system, by its mechanical structure, the movement of the gear shift lever, which is located beside the driver's seat, directly actuates the gear shift fork shaft to shift the gear into the selected position. This system consists of the following parts.

1. Gear shift lever knob
2. Gear shift lever
3. Gear shift lever boot No. 2
4. Gear shift lever boot No. 1
5. Gear shift lever case cover
6. Gear shift lever locating bolt
7. Gear shift lever case
8. Reverse select pin screw
9. Reverse select locating springs
10. Reverse select locating ball
11. Reverse select guide pin
12. Reverse gear shift fork shaft
13. High speed gear shift fork shaft
14. Select return springs
15. Low speed select pin bolt
16. Low speed select guide pin
17. Low speed gear shift fork shaft
18. Gear shift lever wave washer
19. Gear shift lever seat

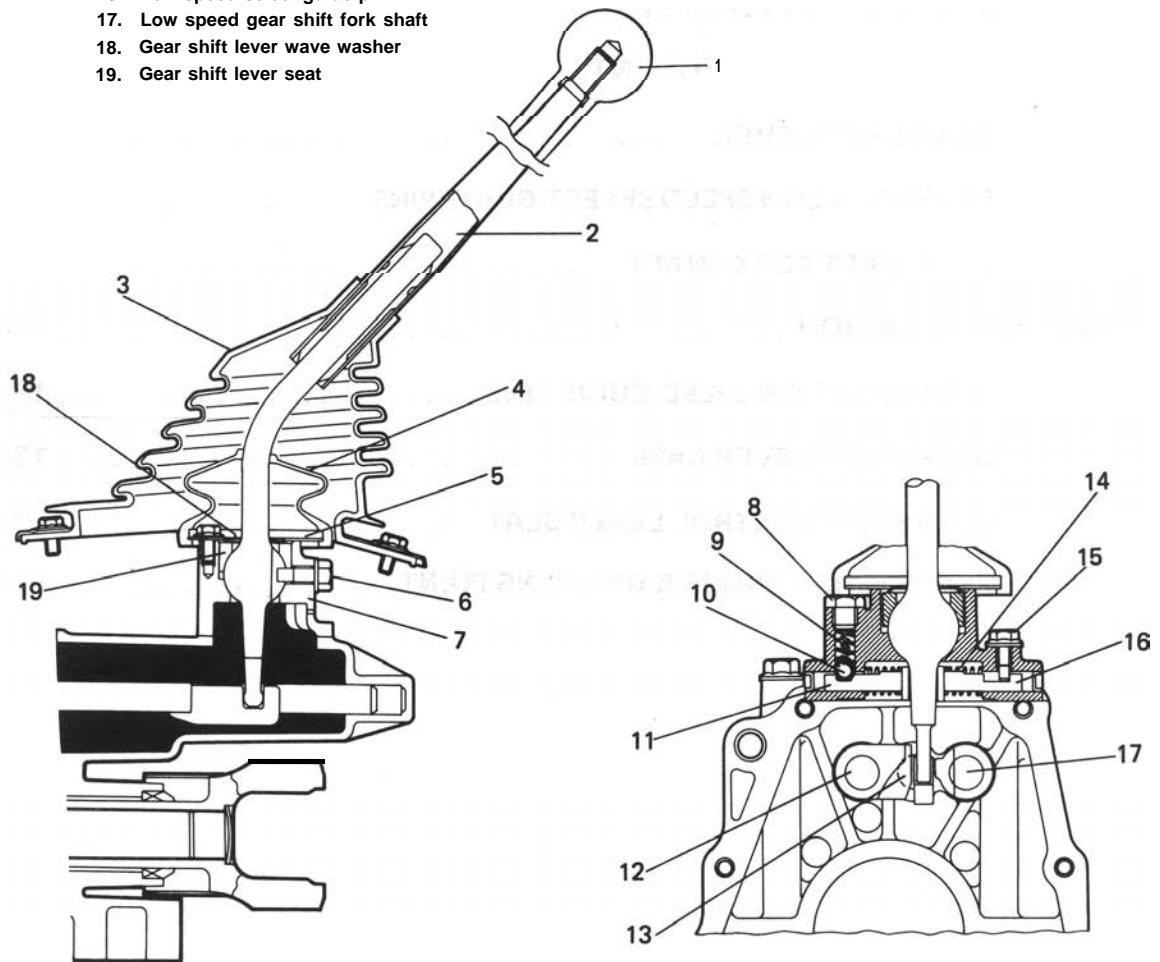


Fig. 12- 1



## 12-2. REMOVAL

### Gear Shift Lever

- 1) Remove bolts tightening gear shift lever boot No. 2 and take boot off floor center tunnel.

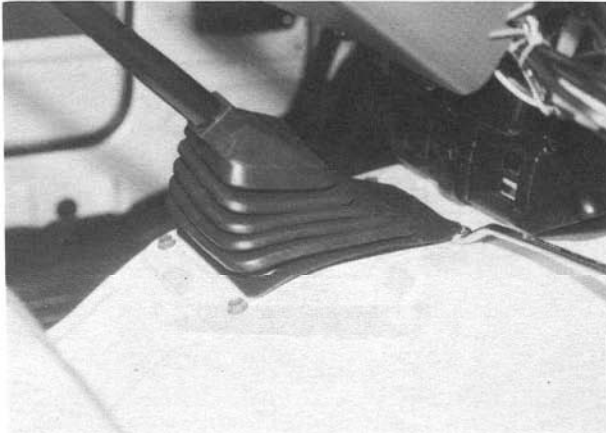


Fig. 12-2

- 2) Take boot No. 1 off gear shift lever case and move it up (toward knob).
- 3) Remove 3 bolts tightening gear shift lever case cover.

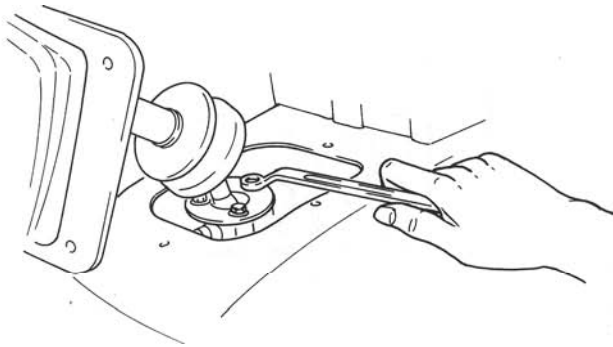


Fig. 12-3

- 4) Pull gear shift lever out of gear shift lever case.

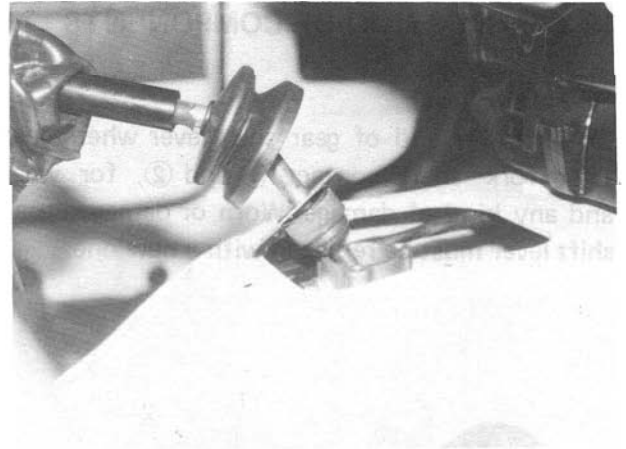


Fig. 12-4

### Gear Shift Lever Select Guide Pins

- 1) After gear shift lever is removed according to foregoing steps 1) through 4), remove gear shift lever case by loosening its tightening bolts.



Fig. 12-5

- 2) Remove reverse select pin screw and take out spring and ball from case.
- 3) Remove low speed select pin bolt.
- 4) Compress reverse select guide pin ② against low speed select guide pin ① and take it out of gear shift lever case.

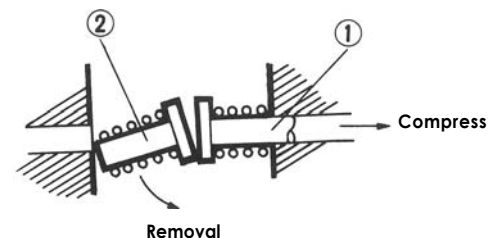


Fig. 12-6

### 12-3. INSPECTION OF COMPONENTS

#### Gear Shift Lever

Check lower end of gear shift lever where gear shift fork shaft contact, ① and ②, for wear and any kind of damage. Worn or damaged gear shift lever must be replaced with a new one.

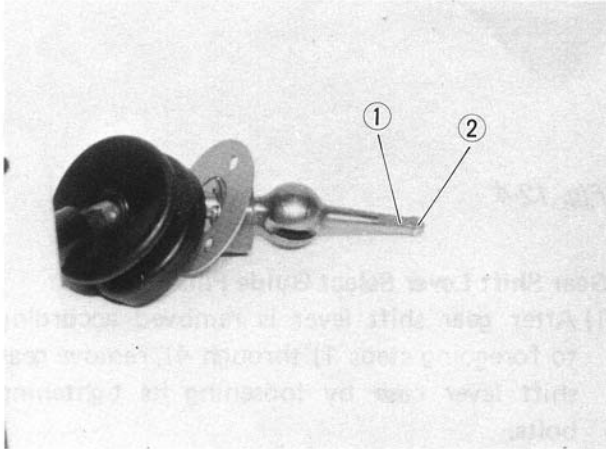


Fig. 12-7

#### Reverse & Low Speed Select Guide Pins

Check both select guide pins where gear shift lever contacts, ③, for stepped wear. Replace worn select guide pin.

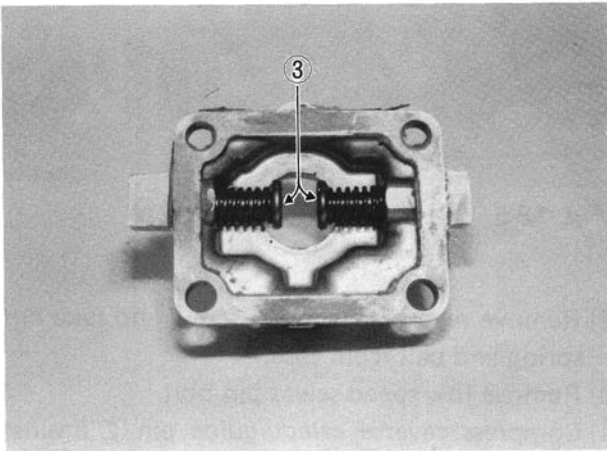


Fig. 12-8

Move shaft and check low speed select guide pin for smooth movement without rattle. If found defective, replace it and apply grease to pin.

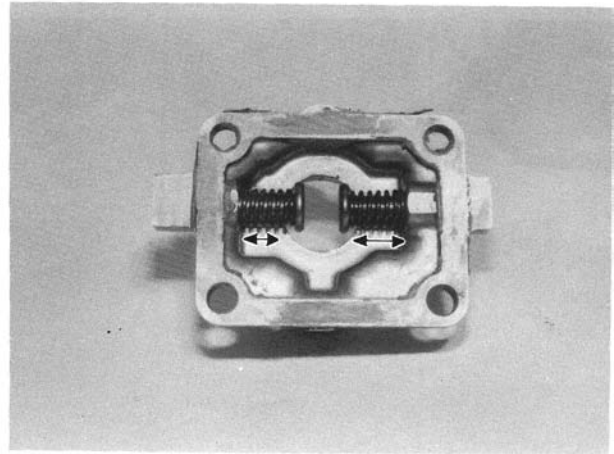


Fig. 12-9

#### Gear Shift Fork Shaft

Visually check each gear shift fork shaft (High, Low and Reverse) where gear shift lever contacts, ④, for wear. Worn shaft must be replaced.

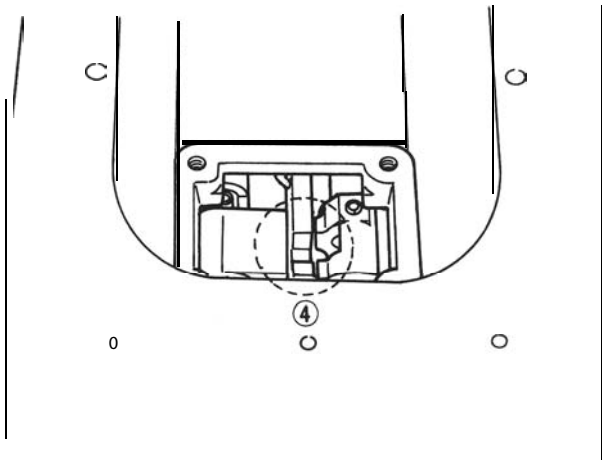


Fig. 12-10

## 12-4. INSTALLATION

Gear shift lever is installed by reversing removal procedure. Some important steps will be explained in detail.

### Reverse & Low Speed Guide Pins

Be sure to apply grease to select guide pins before installing them into gear shift lever case.

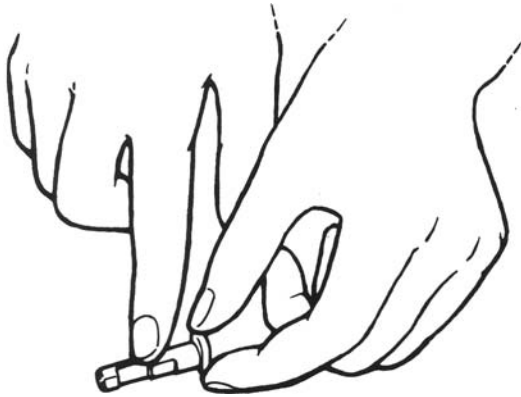


Fig. 12-11

When fitting low speed select guide pin into gear shift lever case, tighten locating bolt while pushing pin so that bolt goes in the groove provided in the pin. Then install reverse select guide pin in case and securely fit the locating ball in the groove provided in the pin.

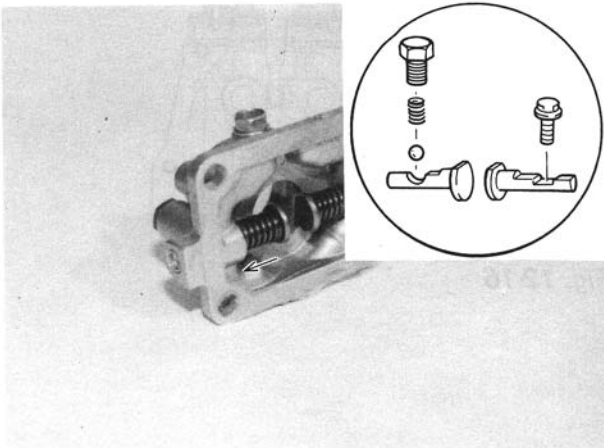


Fig. 12-12

### NOTE:

After each guide pin is installed, make sure that flat surface ⑤ at the tip of pin faces upward (toward gear shift lever).

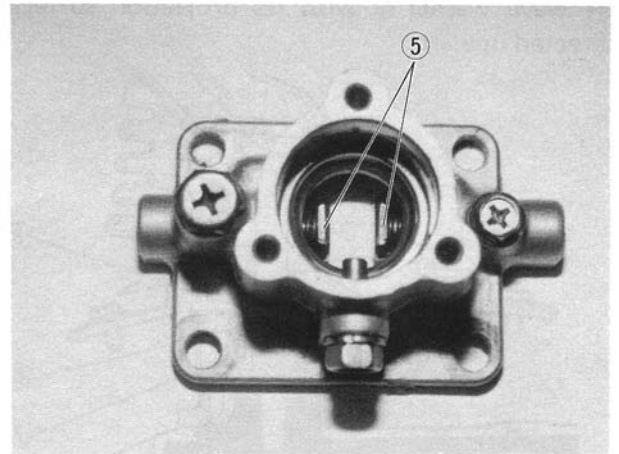


Fig. 12-13

### Gear Shift Lever Case

When installing lever case to transmission extension case, clean joint faces, and then apply sealant (SUZUKI BOND NO. 1215, 99000-31110) to joint faces.

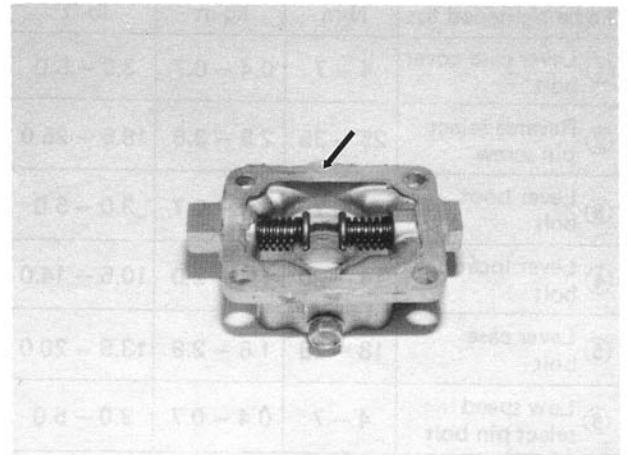


Fig. 12-14

### Gear Shift Control Lever Seat

Make sure to fit control lever seat ⑥ into gear shift lever case so that locating bolt ⑦ goes in the groove of control lever seat. And fit wave washer ⑧ with its projection surface directed upward.

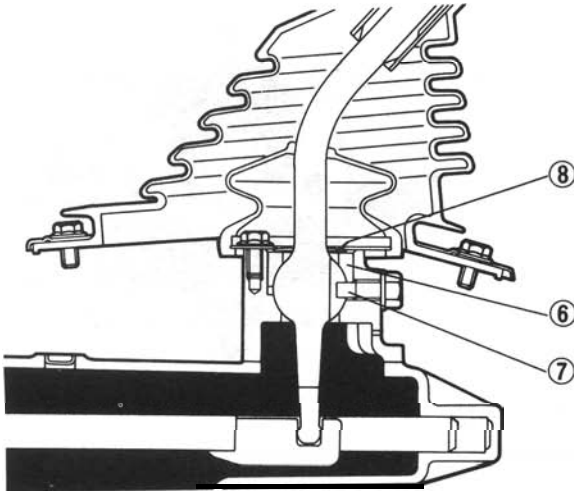


Fig. 12-15

### Tightening Torque & Greasing point

To be tightened to:	N·m	kg·m	lb·ft
① Lever case cover bolt	4 - 7	0.4 - 0.7	3.0 - 5.0
② Reverse select pin screw	25 - 35	2.5 - 3.5	18.5 - 25.0
③ Lever boot bolt	4 - 7	0.4 - 0.7	3.0 - 5.0
④ Lever locating bolt	14 - 20	1.4 - 2.0	10.5 - 14.0
⑤ Lever case bolt	18 - 28	1.8 - 2.8	13.5 - 20.0
⑥ Low speed select pin bolt	4 - 7	0.4 - 0.7	3.0 - 5.0

### Apply to

- Ⓐ : Between gear shift lever boot No. 1 and lever case cover
- Ⓑ : Between gear shift lever and lever seat
- Ⓒ : Between gear shift lever and lever case
- Ⓓ : Gear shift lever locating bolt

\* Grease to be used for each greasing point is SUZUKI SUPER GREASE A(99000-25010).

\* If gear shift lever locating bolt is removed from case, be sure to apply locking agent (THREAD LOCK CEMENT SUPER "1333B" 99000-32020) to bolt thread for reinstallation.

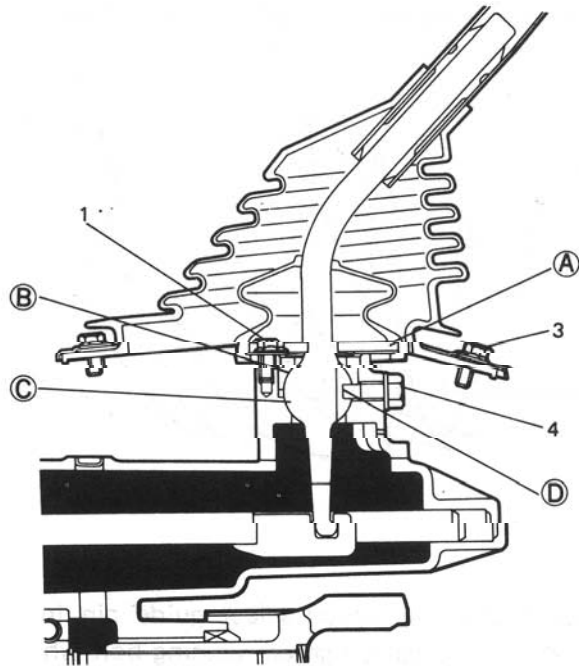
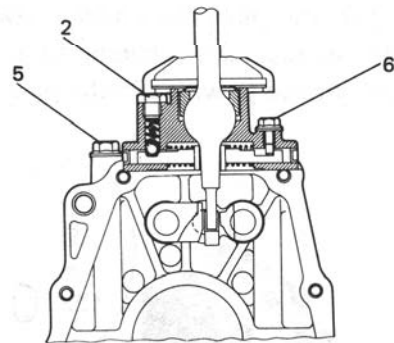


Fig. 12-16



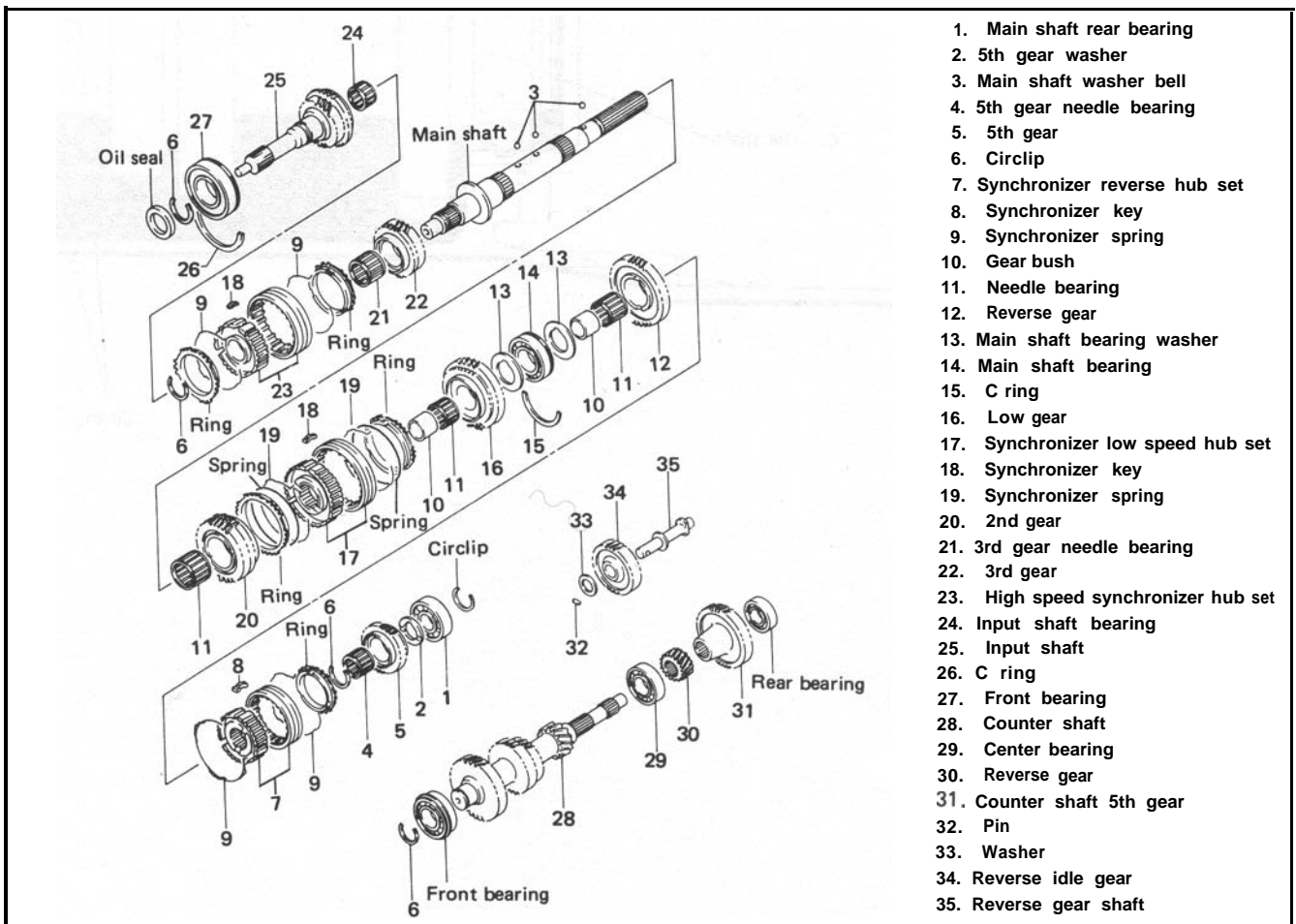
## SECTION 13

# TRANSMISSION

### CONTENTS

13-1. GENERAL DESCRIPTION .....	13-1
13-2. TRANSMISSION GEAR RATIO .....	13-3
13-3. DISMOUNTING. ....	13-4
13-4. DISASSEMBLY .....	13-5
13-5. INSPECTION OF COMPONENTS .....	13-12
13-6. IMPORTANT STEPS IN INSTALLATION .....	13-15
13-7. MAINTENANCE SERVICES .....	13-25
13-8. RECOMMENDED TORQUE SPECIFICATION .....	13-26

### 13-1. GENERAL DESCRIPTION



1. Main shaft rear bearing
2. 5th gear washer
3. Main shaft washer bell
4. 5th gear needle bearing
5. 5th gear
6. Circlip
7. Synchronizer reverse hub set
8. Synchronizer key
9. Synchronizer spring
10. Gear bush
11. Needle bearing
12. Reverse gear
13. Main shaft bearing washer
14. Main shaft bearing
15. C ring
16. Low gear
17. Synchronizer low speed hub set
18. Synchronizer key
19. Synchronizer spring
20. 2nd gear
21. 3rd gear needle bearing
22. 3rd gear
23. High speed synchronizer hub set
24. Input shaft bearing
25. Input shaft
26. C ring
27. Front bearing
28. Counter shaft
29. Center bearing
30. Reverse gear
31. Counter shaft 5th gear
32. Pin
33. Washer
34. Reverse idle gear
35. Reverse gear shaft

Fig. 13-1

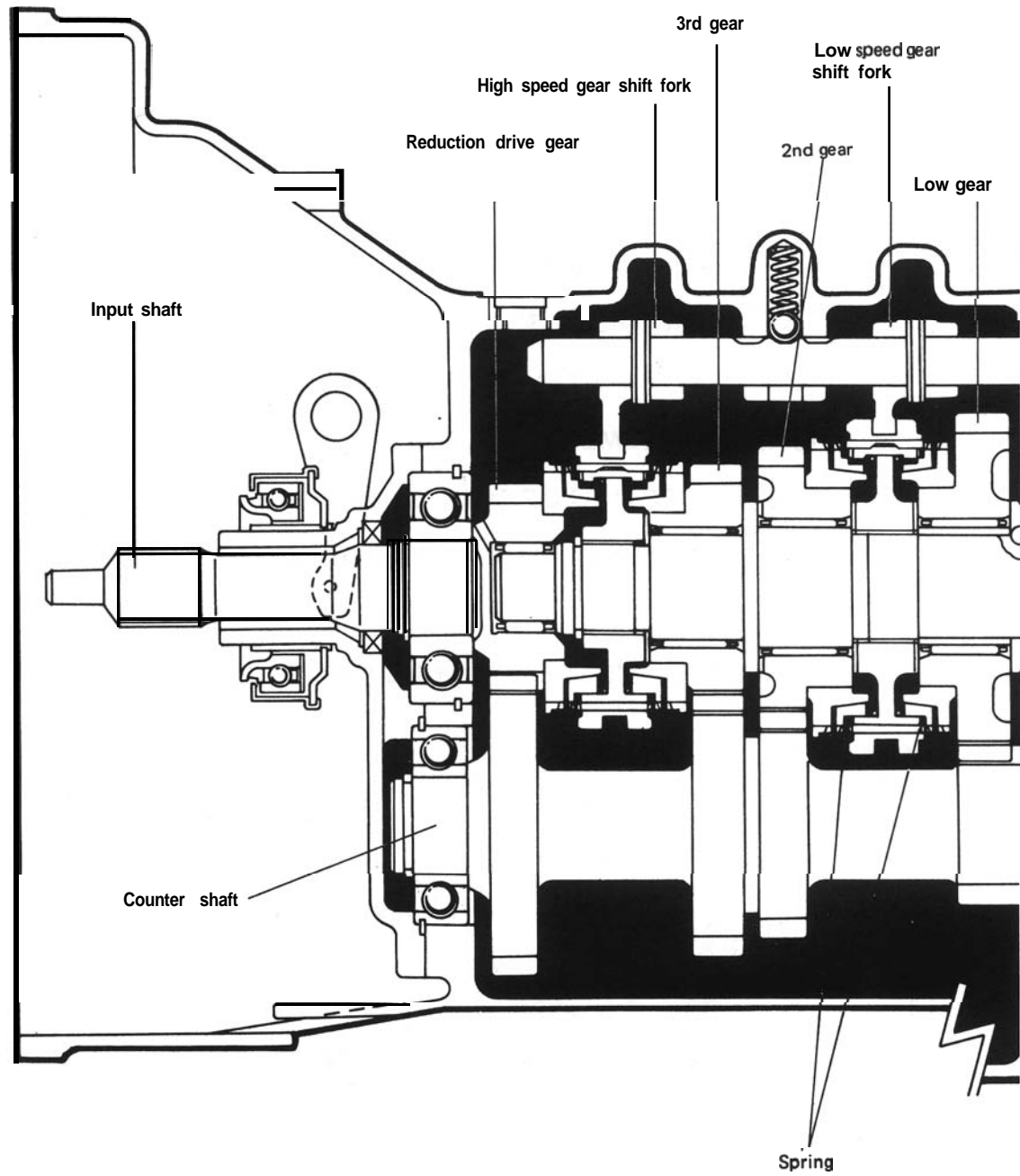
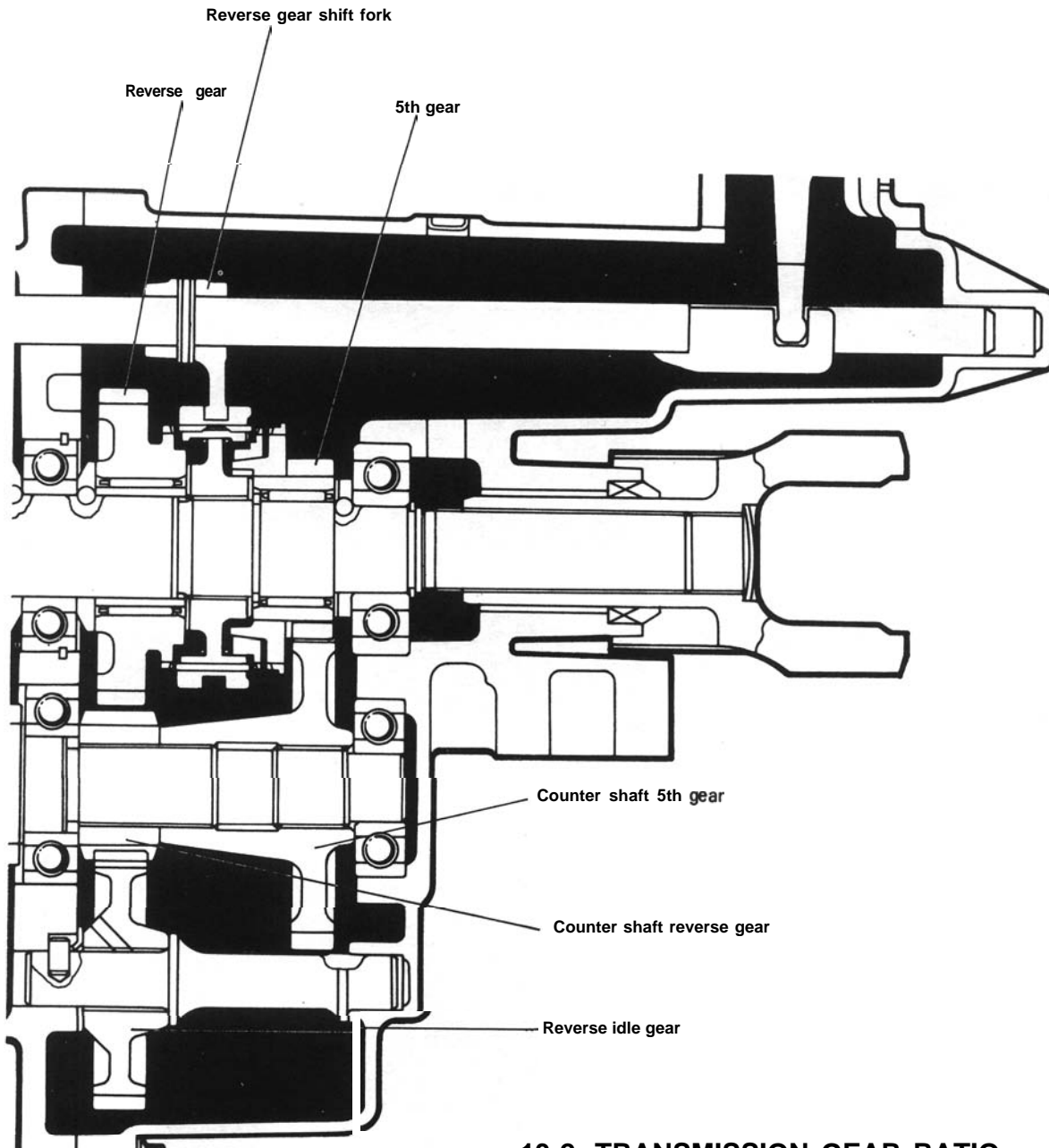


Fig. 13-2



### 13-2. TRANSMISSION GEAR RATIO

Primary gear ratio		35/23				—	35/23		
Primary speed ratio		1.521				—	1.521		
Secondary ratios		Shift position		Reverse	Low	Second	Third	Fourth	Fifth
		Gear ratio		41/18	36/15	32/25	29/31	—	25/44
		Speed ratio		2.277	2.400	1.280	0.935	—	0.568
Overall speed reduction ratio				3.466	3.652	1.947	1.423	1.000	0.864

### 13-3. DISMOUNTING

#### In Passenger Compartment

- 1) Loosen 4 bolts fastening gear shift lever boot No. 2 and move boot upward.



Fig. 13-2-1

- 2) Move gear shift boot No. 1 upward. Loosen gear shift lever case cover bolts (3 pcs) and draw gear shift lever out of lever case.

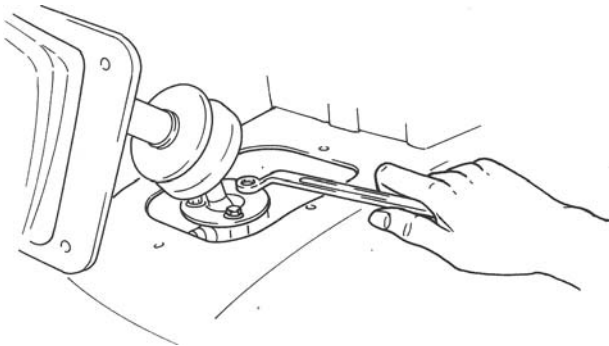


Fig. 13-2-2

#### In Engine Room

- 3) Disconnect negative (-) and positive (+) cords from battery terminals.
- 4) Disconnect back light and fifth switch lead wires at coupler respectively.
- 5) Disconnect Black/Yellow lead wire and positive (+) cord from starter motor.
- 6) Remove starter motor from transmission case and fuel hoses clamp from transmission case.

#### Under Engine

- 7) Remove drain plug to drain oil in transmission.
- 8) Disconnect clutch wire from clutch release lever.
- 9) Remove propeller shaft No. 1 (from transmission to transfer).
- 10) Remove propeller shaft No. 2 (from transfer to front differential).
- 11) Remove clutch housing lower plate from transmission case.

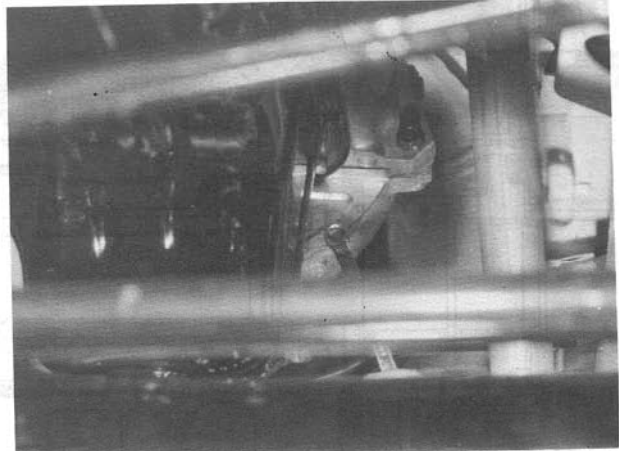


Fig. 13-2-3

- 12) Remove bolts and nuts fastening engine cylinder block and transmission case.
- 13) Remove pipe ① as shown in Fig. 13-24.

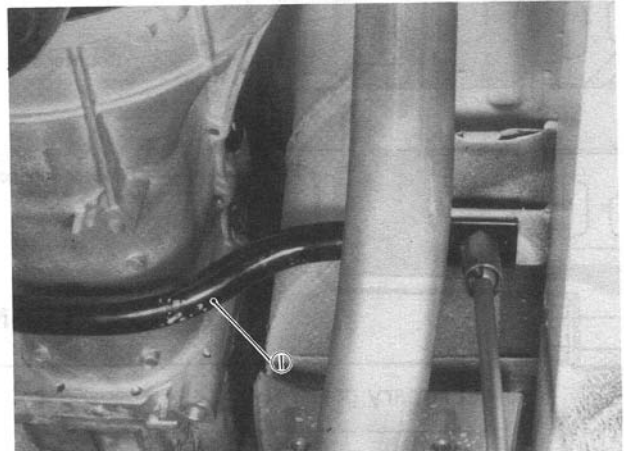


Fig. 13-2-4

- 14) Remove exhaust center pipe.
- 15) Remove transmission rear mounting bracket from chassis and transmission case.

#### NOTE:

Before starting to remove transmission, check around once again to be sure that there is no connection left undone.

- 16) Take down transmission.



## 13-4. DISASSEMBLY

### Replacing Clutch Release Shaft Bush

- 1) Remove clutch release bearing from input shaft bearing retainer.

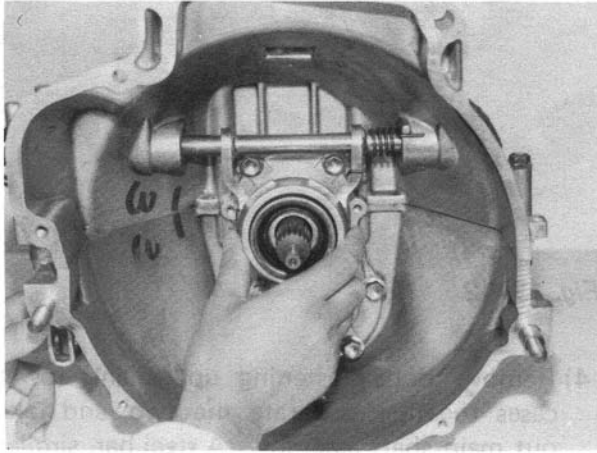


Fig. 13-3

- 2) Remove a part of spring from clutch release shaft lever.

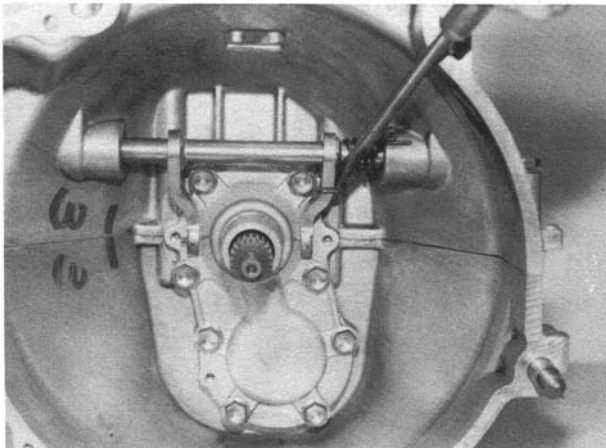


Fig. 13-3-1

- 3) Remove clutch release shaft spring from shaft. With special tool (A) applied in such a position as shown in Fig. 13-3-2, tap the end of special tool to take out bush and cap. Clutch release bush remover (A) (09925 48210)

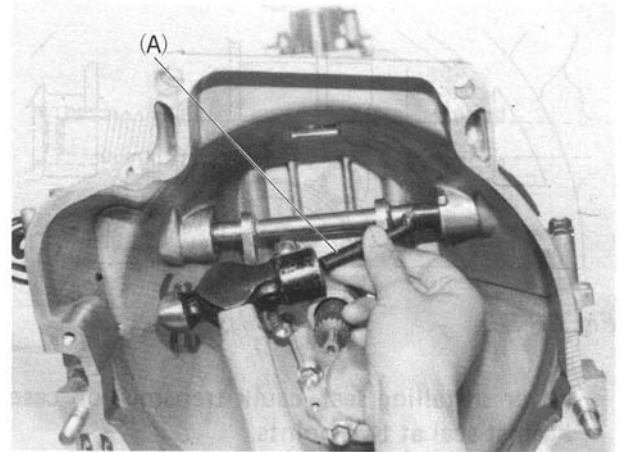


Fig. 13-3-2

- 4) Take out the other bush, too.

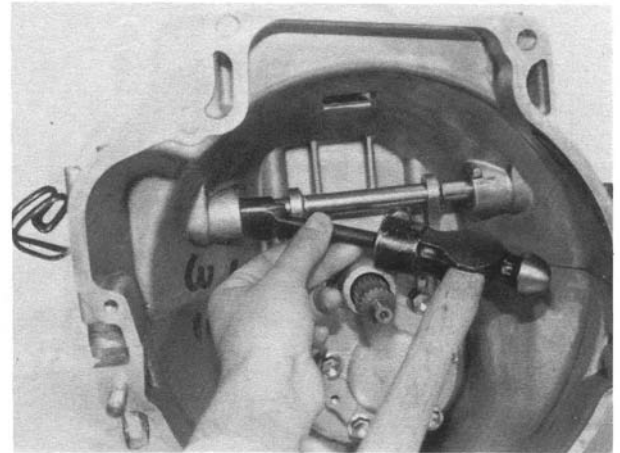


Fig. 13-3-3

- 5) Precautions on bush reinstallation:

- Make sure to apply grease to inside of bushes.
- Drive in bushes to the same level as inside surface of transmission case. Install cap and oil seal securely after greasing oil seal lip.

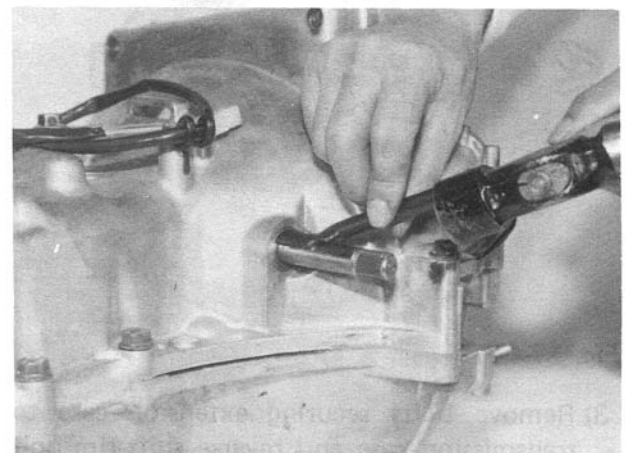
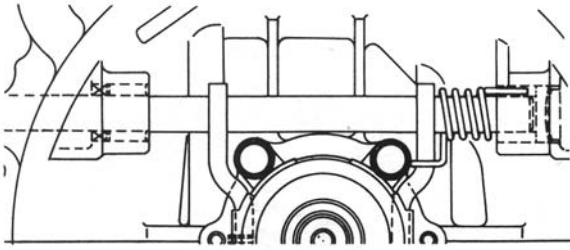


Fig. 13-3-4

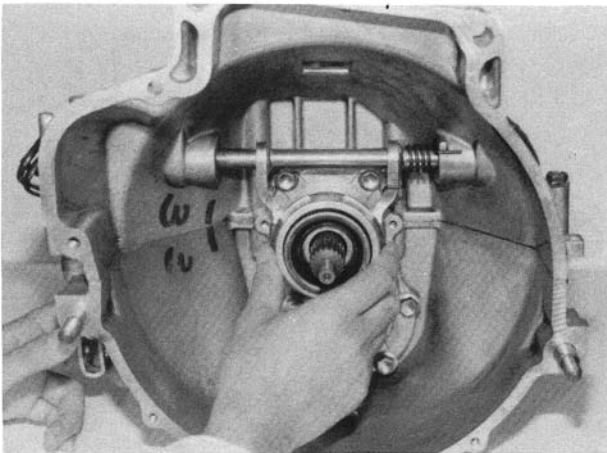


**Fig. 13-3-5**

- After installing seal, caulk transmission case against seal at two points.

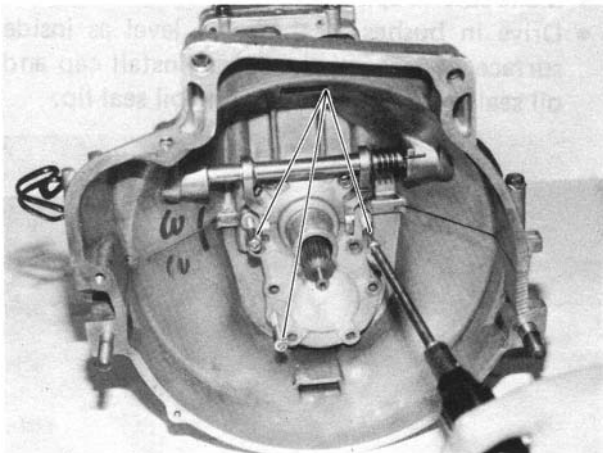
**Separating Upper Case from Lower Case**

- 1) Remove clutch release bearing from transmission input shaft.



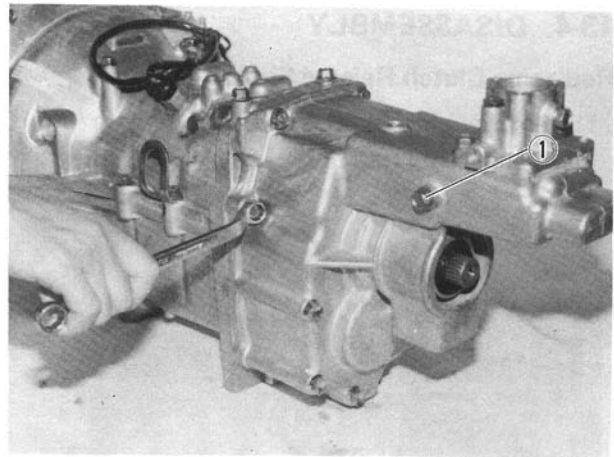
**Fig. 13-4**

- 2) Remove input shaft bearing retainer bolts and pull out retainer by using 3 conventional 6 mm bolts.



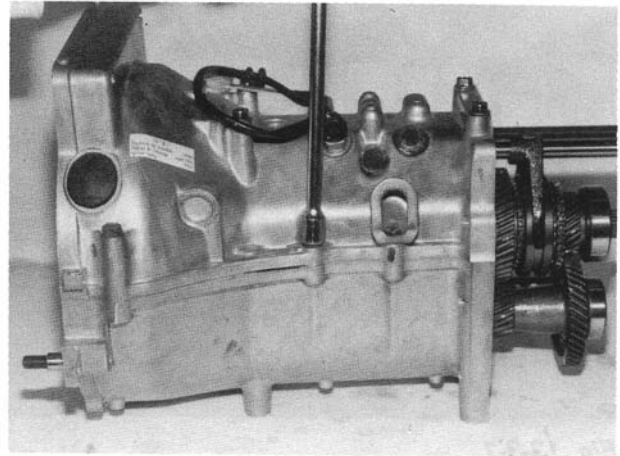
**Fig. 13-4-1**

- 3) Remove bolts securing extension case to transmission case and reverse shift rim bolt ①. Then take off extension case.

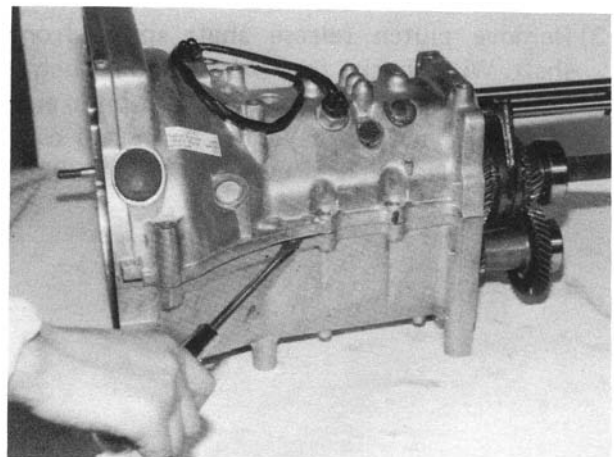


**Fig. 13-4-2**

- 4) Remove bolts fastening upper and lower cases together, separate the two, and take out main shaft assembly. A steel bar, similar in shape to screwdriver, may have to be used to pry two cases apart, as shown. In such a case, do not stick bar too far into between two mating faces, or faces may become damaged.



**Fig. 13-5**



**Fig. 13-5-1**

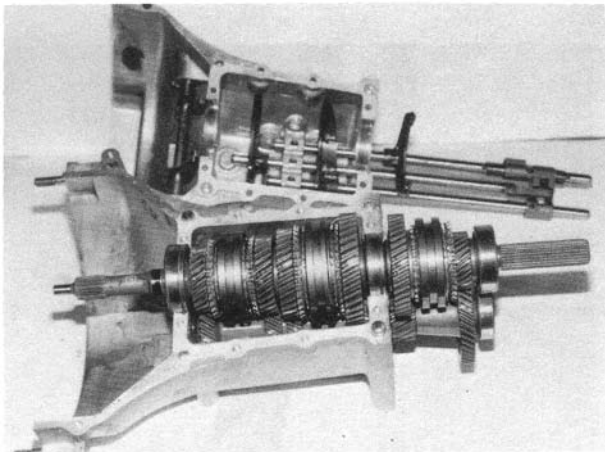


Fig. 13-5-2

### Removing Countershaft

- 1) Remove reverse gear shaft with gear.

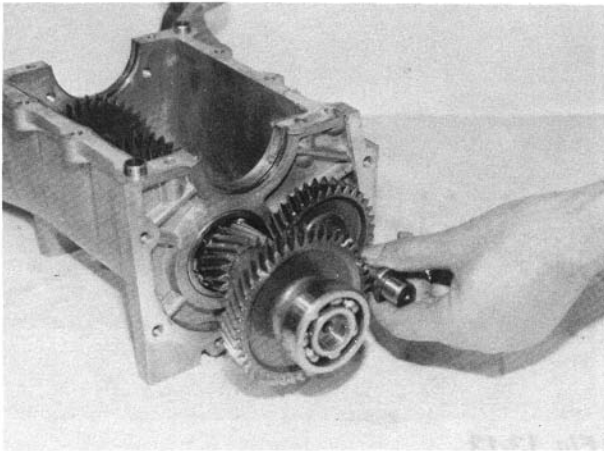


Fig. 13-6

- 2) Remove countershaft rear bearing.

Bearing puller (B) (09913-65135)

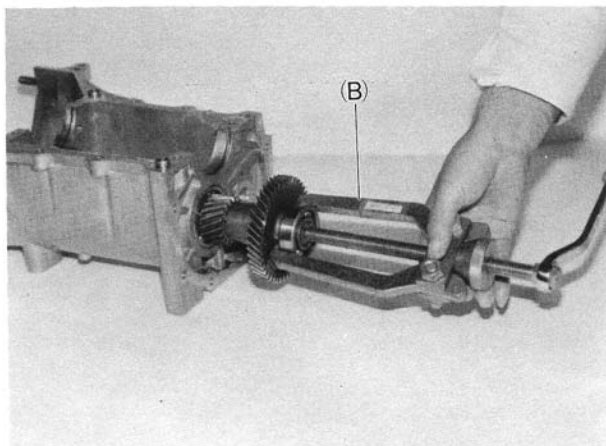


Fig. 13-7

- 3) Remove counter-shaft 5th gear and counter-shaft reverse gear.

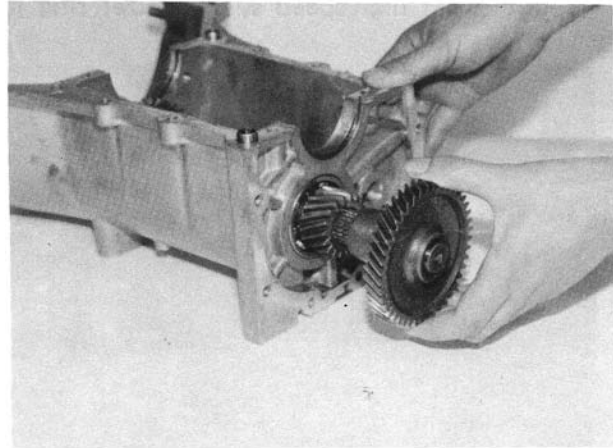


Fig. 13-8

- 4) Remove circlip from countershaft. Push out countershaft to extension case side by using hydraulic press, remove bearing, and take countershaft assembly out of case.

Bearing puller (B) (09913-65135)

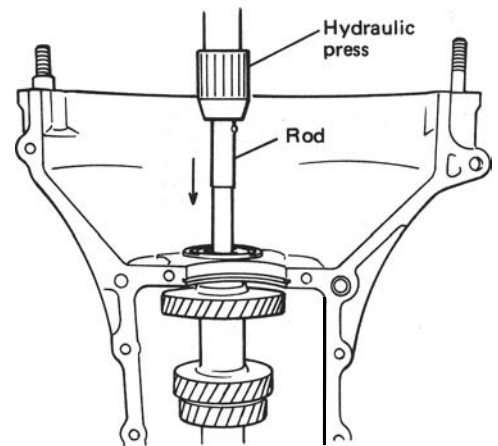


Fig. 13-9

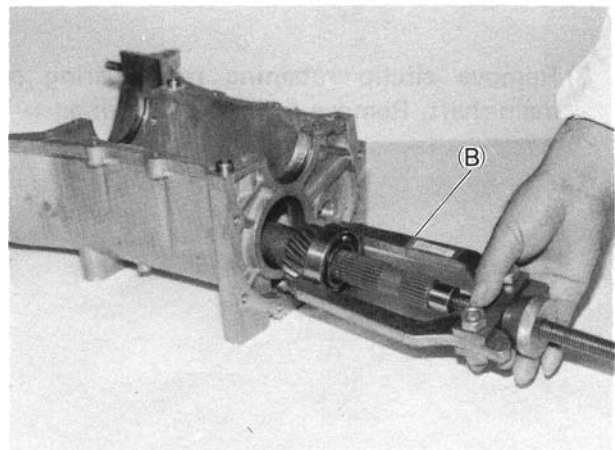
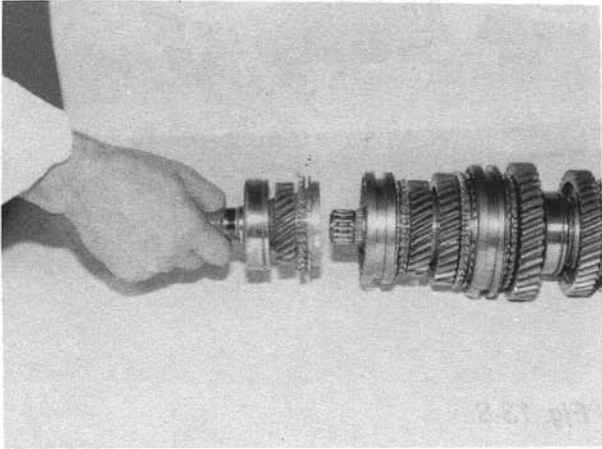


Fig. 13-9-1

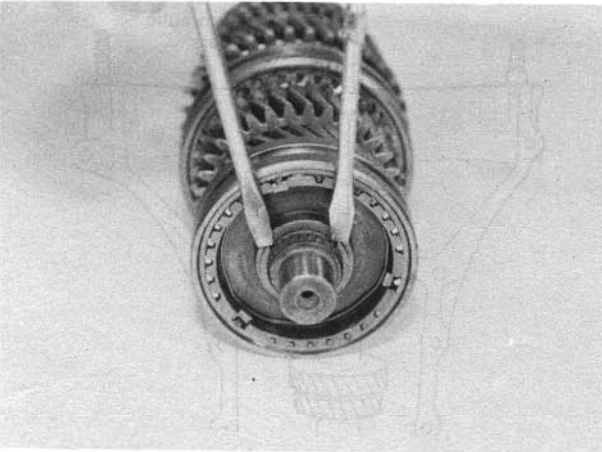
## Removing Main Shaft and Input Shaft

- 1) Take out input shaft by hand, taking care not to let high-speed synchronizer ring fall off.



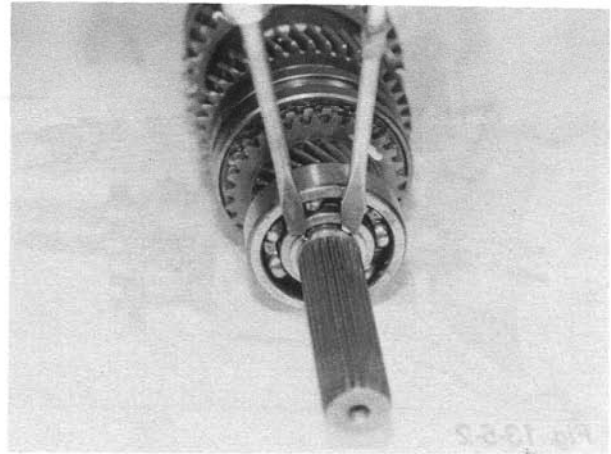
**Fig. 13-10**

- 2) Remove circlip retaining hub of high-speed synchronizer sleeve, and slide off sleeve hub, third driven gear and needle bearing from main shaft.



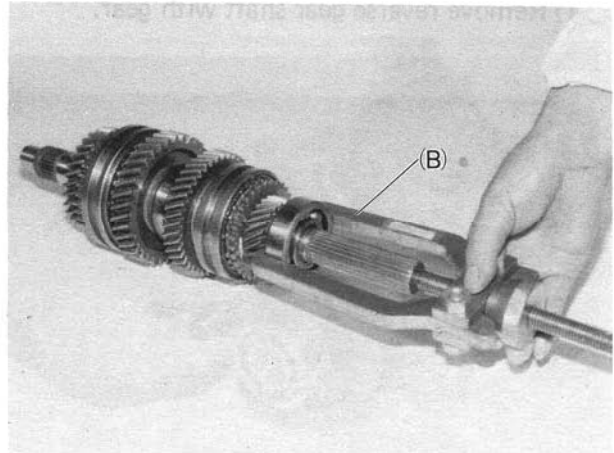
**Fig. 13-1 1**

- 3) Remove circlip retaining rear bearing on main shaft. Remove main shaft bearing.



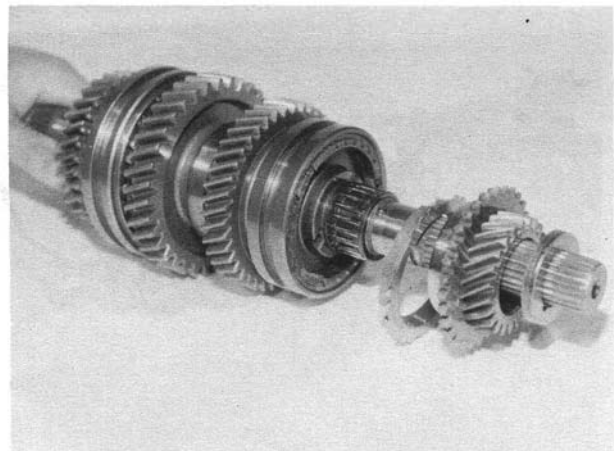
**Fig. 13-12**

**Bearing puller (B) (09913-65135)**



**Fig. 13-13**

- 4) From main shaft, take off 5th gear washer, ball, 5th gear, 5th speed synchronizer ring and 5th gear needle bearing,



**Fig. 13-14**

- 5) Remove circlip retaining the reverse synchronizer hub on main **shaft**.

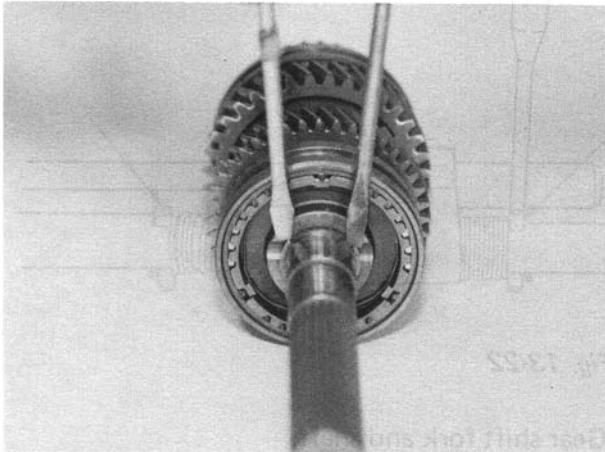


Fig. 13-15

- 6) Remove reverse synchronizer hub, reverse gear and reverse gear needle bearing.

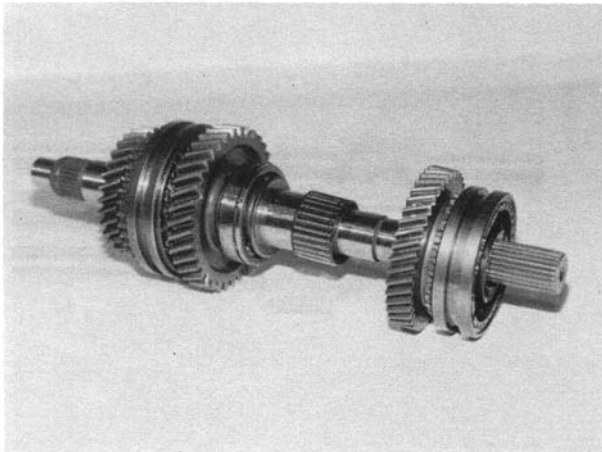


Fig. 13-16

- 7) Remove bearing washer and reverse gear bush on main shaft by using hydraulic press.

**NOTE:**

During this removal, watch out for a ball which may fall off. It must not be lost. Also, ball bearing should not be removed together with above washer and bush.

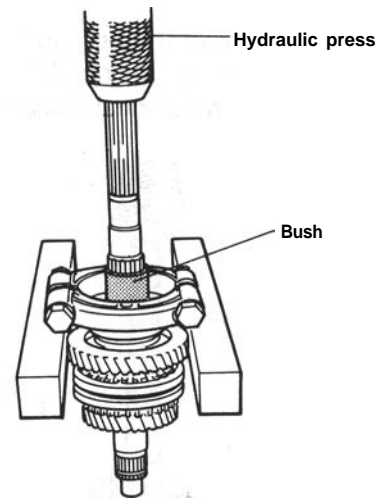


Fig. 13-17

- 8) Remove ball and main shaft (center) bearing by using hydraulic press.

**NOTE:**

In the state as shown below, there is a ball in washer which is located under bearing. Be sure to prevent it from falling off and getting lost.

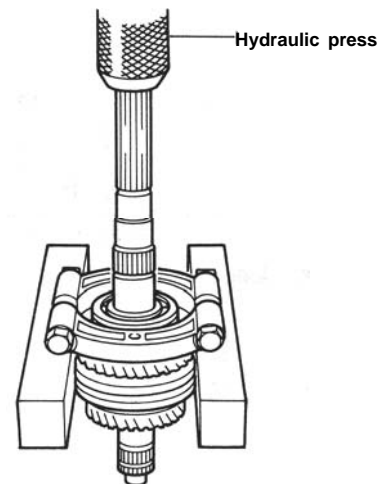


Fig. 13-18

- 9) Remove low gear, needle bearing, synchronizer ring and spring on main shaft.

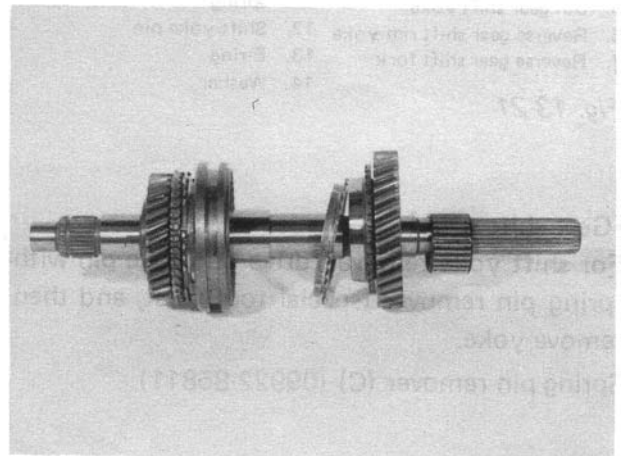


Fig. 13-19



10) Remove low gear bush, low speed synchronizer hub, ring, spring, 2nd gear and 2nd gear bearing by using hydraulic press.

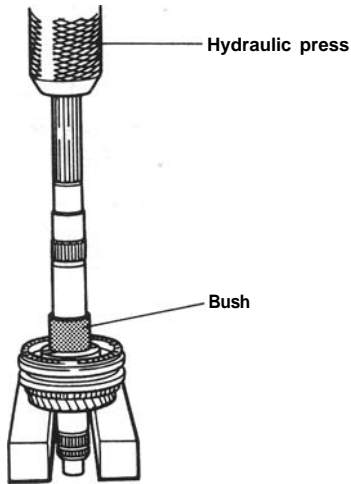
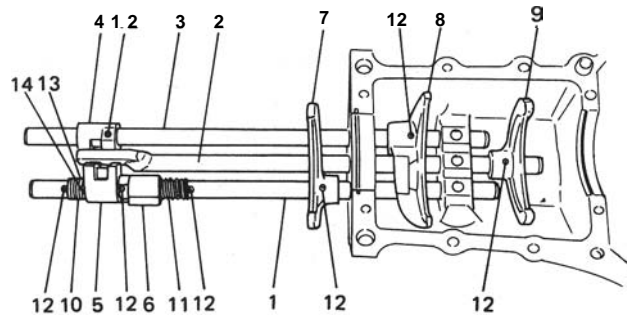


Fig. 13-20

**Removing Shift Yokes, Forks and Shafts**



- |                                |                                   |
|--------------------------------|-----------------------------------|
| 1. Reverse gear shift shaft    | 8. Low speed gear shift fork      |
| 2. High speed gear shift shaft | 9. High speed gear shift fork     |
| 3. Low speed gear shift shaft  | 10. 5th select return spring      |
| 4. Low speed gear shift yoke   | 11. Reverse gear shift rim spring |
| 5. 5th gear shift yoke         | 12. Shift yoke pin                |
| 6. Reverse gear shift rim yoke | 13. E-ring                        |
| 7. Reverse gear shift fork     | 14. Washer                        |

Fig. 13-21

[Gear shift yoke]

For shift yoke removal, drive out yoke pin with spring pin remover (special tool) first, and then remove yoke.

Spring pin remover (C) (09922-85811)

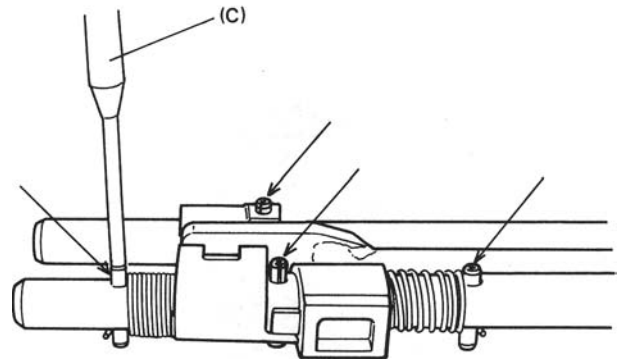


Fig. 13-22

[Gear shift fork and shaft]

Before starting removal, make sure that all shift fork shafts in place are in neutral position and remove each fork and shaft according to following 1), 2) and 3).

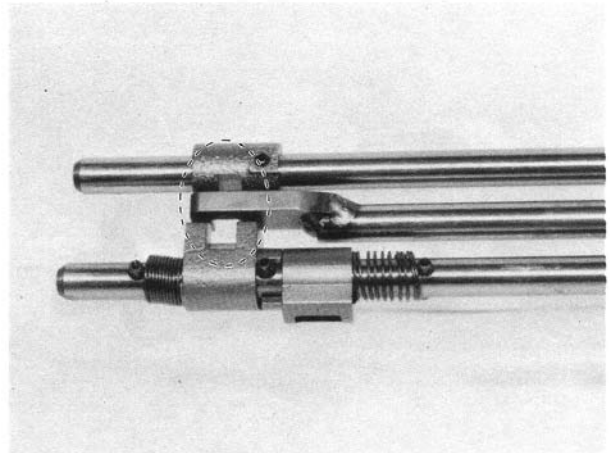


Fig. 13-23 Neutral position

1) Pull out reverse gear shift shaft. As this shaft comes out, locating ball and spring will jump out of hole; do not let them fly away.

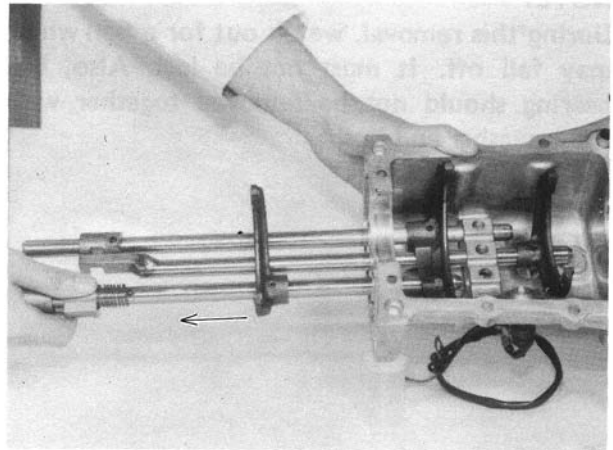
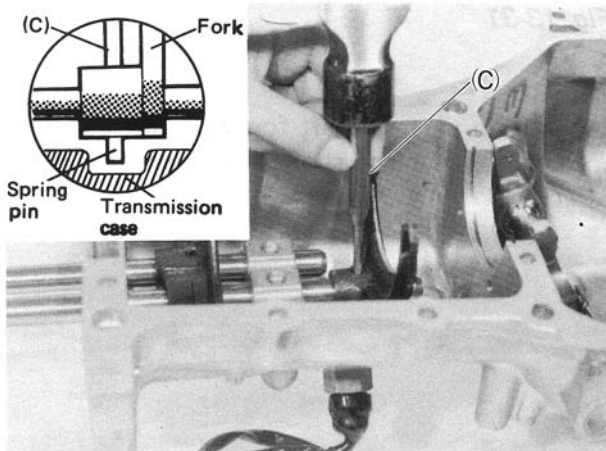


Fig. 13-24

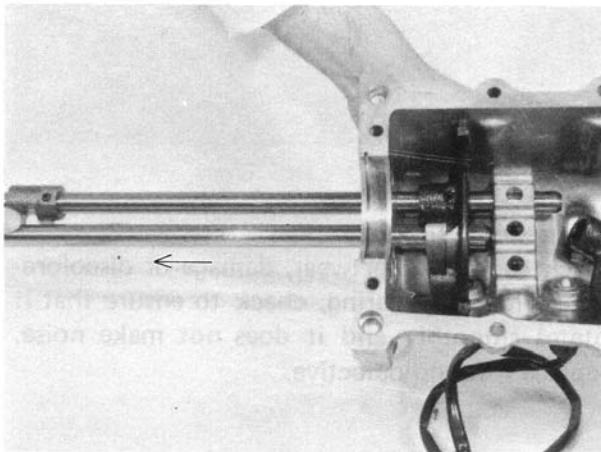
2) Using the same special tool (C), mentioned above, drive out yoke pin on high speed gear shift fork, and pull out shift shaft. As in above case, be careful not to let locating ball, interlock ball and spring fly away.

**CAUTION:**

When removing yoke pin, be sure not to drive it out so far as to contact case. Or it will cause damage to case.

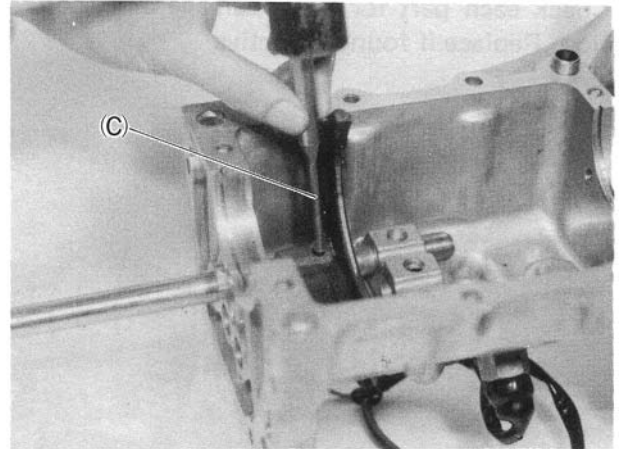


**Fig. 13-25**

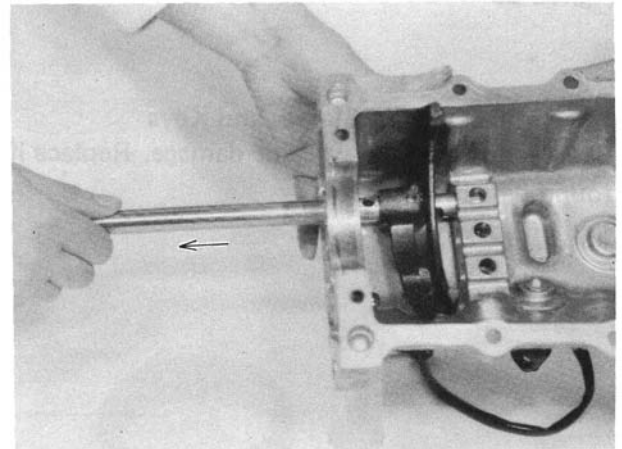


**Fig. 13-26**

3) Drive yoke pin out of low speed gear shift fork as in above step 2) and pull out fork shaft and fork.



**Fig. 13-27**



**Fig. 13-28**

## 13-5. INSPECTION OF COMPONENTS

### Gears

Check each part for wear, damage or discoloration. Replace if found defective.

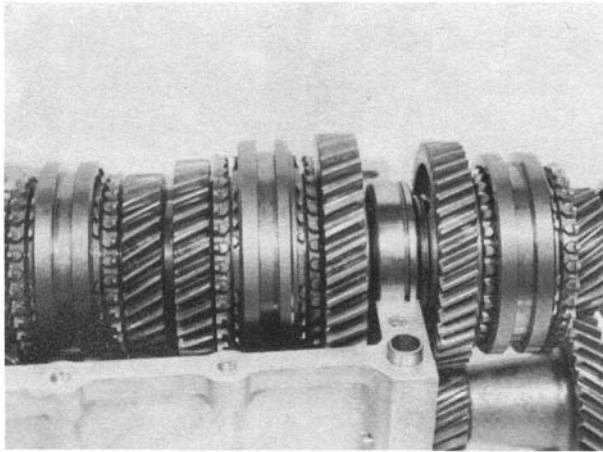


Fig. 13-29

### Synchronizer Hubs, Sleeves and Keys

Check each part for wear or damage. Replace if found defective.

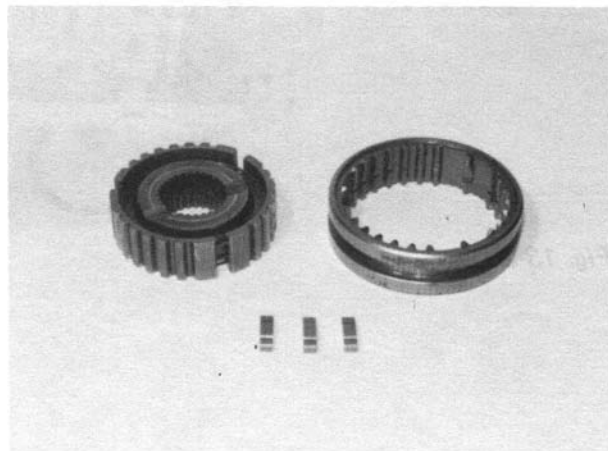


Fig. 13-30

### Shift Forks and Sleeves

Check contact surfaces for wear or damage. Measure clearance between fork and sleeve.

Maximum clearance	1.0 mm (0.039 in)
-------------------	-------------------

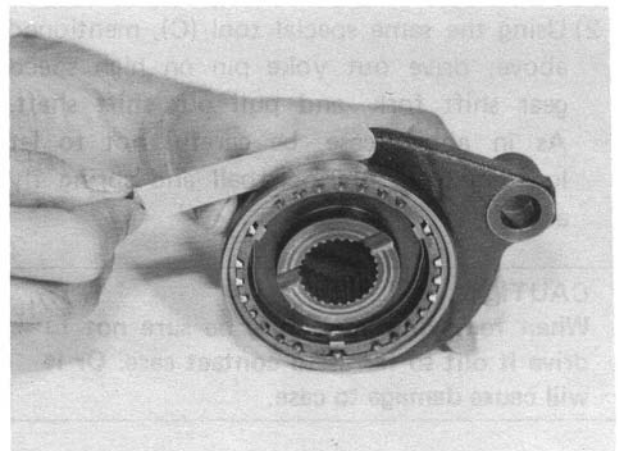


Fig. 13-31

### Main Shaft

Check each part of shaft for wear, discoloration or damage. Replace shaft if any part is found defective.

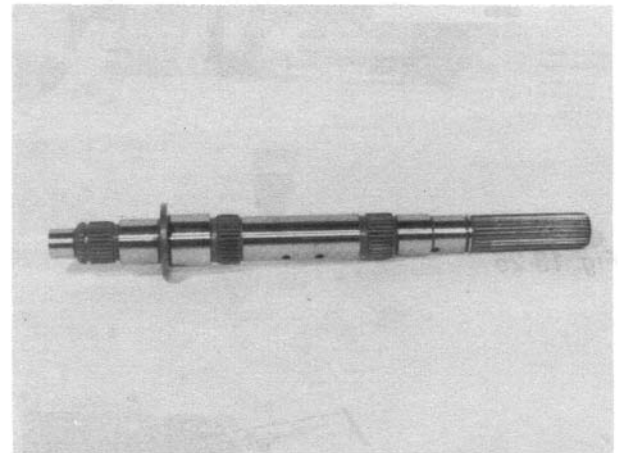


Fig. 13-32

### Bearings and Bushes

Check each part for wear, damage or discoloration. With ball bearing, check to ensure that it rotates smoothly and it does not make noise. Replace if found defective.

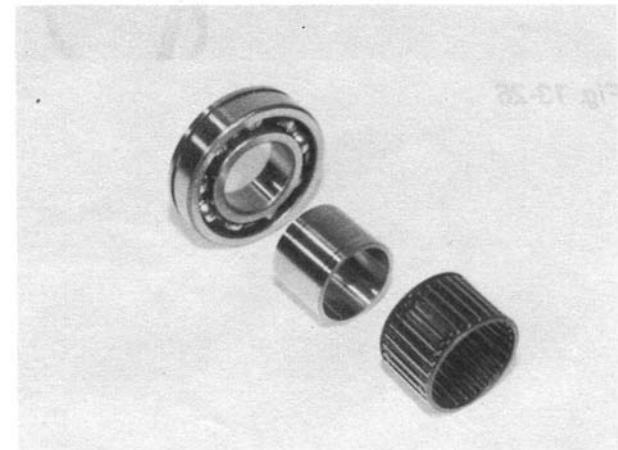


Fig. 13-33



### Input Shaft

Referring to Fig. 13-34, inspect cone ① and toothed ring ② for wear and damage.

Inspect gear teeth ③ and splines ④ for wear and damage.

If any part of input shaft inspected as above is found excessively worn or badly damaged, replace shaft.

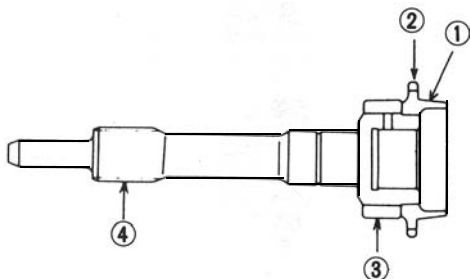


Fig. 13-34

### Combination of Gear and Synchronizer Ring

Fit ring to cone of each gear, and measure clearance between the two at peripheral teeth, as shown in Fig. 13-35. If clearance exceeds service limit, replacement is necessary.

Clearance between gear and ring		
	Standard	Service limit
Low and High speed	1.0 – 1.4 mm (0.039 – 0.055 in.)	0.5 mm (0.019 in.)
5th speed	1.2 – 1.6 mm (0.047 – 0.063 in.)	0.5 mm (0.019 in.)

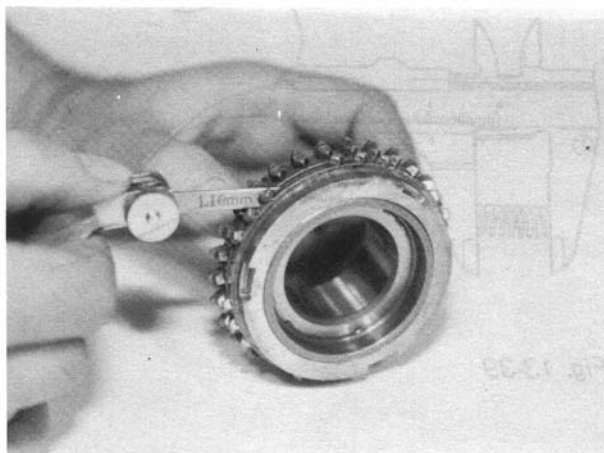


Fig. 13-35

Inspect external cone (of gear) and internal cone (of ring) for abnormal wear. Be sure that contact patterns on these surfaces indicate uniform full-face contact, and that surfaces are free from any wavy wear. A badly worn member must be replaced.

Proper synchronizing action on gear shifting can be expected only when ring-to-gear clearance (Fig. 13-35) and condition of cone surfaces, among other things, are satisfactory.

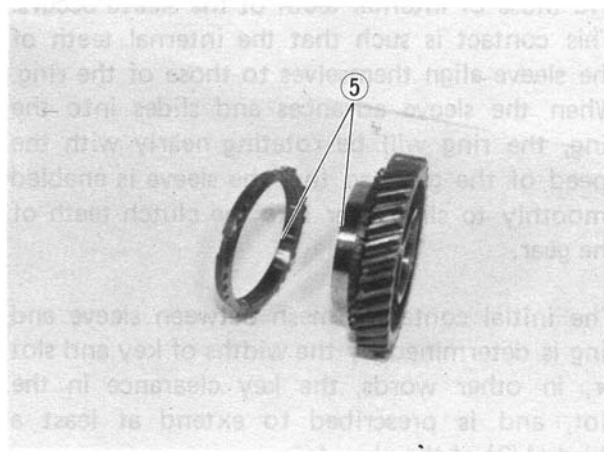


Fig. 13-36 ⑤ Checking contacting surface

### Chamfered Tooth Ends of Ring (External Teeth) and Sleeve (Internal Teeth)

Synchronizer ring and hub have three slots each, in which keys are carried as backed by expanding springs, so that the hub and its two rings, one on each end, are capable of running together. Since the sleeve is engaged by its internal teeth with the hub as if the two were splined together, the sleeve, too, runs with the hub and rings.

In meshing action, the sleeve is pushed (by the shifter fork) to one side, so that it slides axially on the hub, pushing the ring toward the cone surface of the gear. This push is transmitted by three keys, which are lightly gripped by the sleeve.

By friction between the gear cone and ring cone (internal), the ring begins to rotate but is copposed by the hub because of keys. In other words, the ring is at this time twisted, while the sleeve is advancing further to push the ring fully against the gear cone, Since the ring is unable to slide along any further, the sleeve lets go off the keys and rides over to the ring. At this moment, the initial contact between the chamfered ends of teeth of the ring and those of internal teeth of the sleeve occurs. This contact is such that the internal teeth of the sleeve align themselves to those of the ring. When the sleeve advances and slides into the ring, the ring will be rotating nearly with the speed of the gear, so that the sleeve is enabled smoothly to slide over into the clutch teeth of the gear.

The initial contactor mesh between sleeve and ring is determined by the widths of key and slot or, in other words, the key clearance in the slot, and is prescribed to extend at least a third (1/3) of the chamfer.

With the synchronizer properly assembled on the shaft, push in and twist each synchronizer to see if one-third mesh occurs or not; if not, it means that the overall wear (which is the sum of wears of slots, keys and chamfered tooth ends) is excessive and, in such a case, the entire synchronizer assembly must be replaced.

Mesh of chamfered tooth ends of synchronizer ring and sleeve	Contact extending about 1/3 of chamfered face from apex
--	---

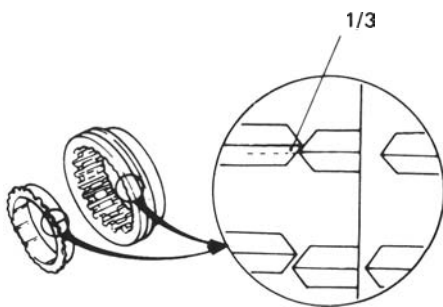


Fig. 13-37

### Synchronizer Rings

Inspect each synchronizer ring for wear of its key slots by measuring width of each slot. If width reading exceeds limit, replace ring.

Key slot width of synchronizer ring	Standard	Service limit
	10.1 mm (0.397 in.)	10.4 mm (0.409 in.)

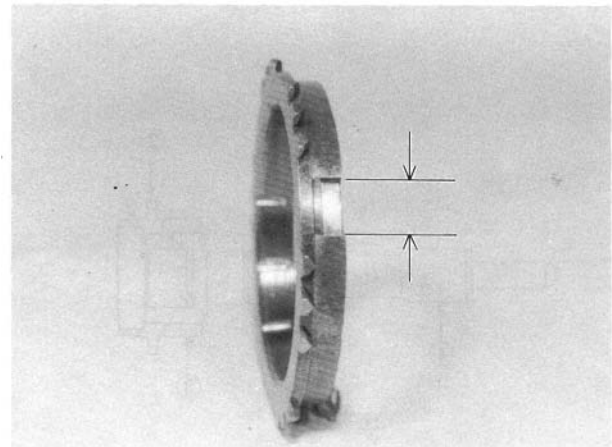


Fig. 73-38

### Fork Shaft Locating Springs

If “gears slipping out of mesh” has been complained, check these springs for strength by measuring their free length, and replace them if their free lengths are less than service limit.

Spring No.	Standard	Service limit
Free length	25.5 mm (1.004 in.)	21.0 mm (0.826 in.)

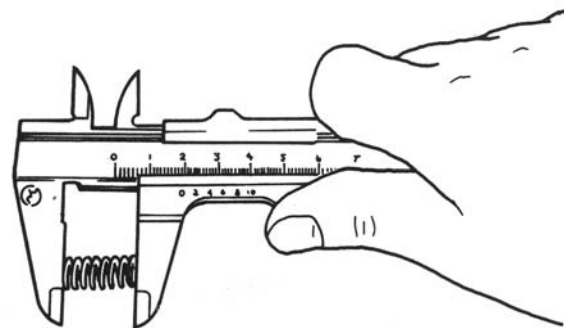


Fig. 73-39

### Gear Shift Shafts

Check the part of shaft as indicated in below figure for uneven wear. Replace shaft if uneven wear is noted.

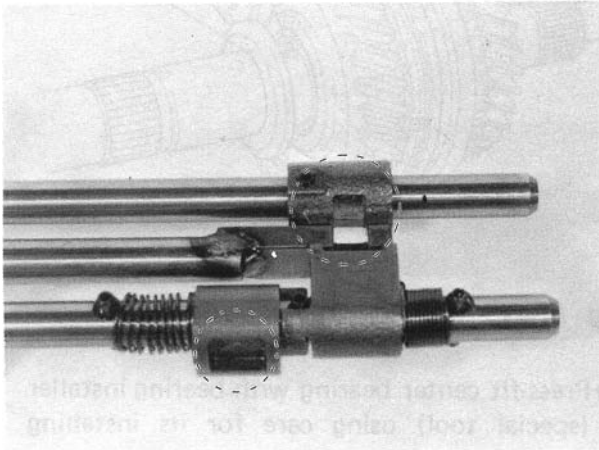


Fig. 13-40

### Extension Case Bush

Check bush press-fitted in extension case for wear by measuring radial clearance between bush bore and sliding yoke. If sliding yoke rattles in bush because of advanced wear it will cause propeller shaft to rattle. For this reason, an extension case found to allow its sliding yoke to rattle in excess of service limit must be replaced; replacement of bush alone is not permissible.

Rattle of sliding yoke in extension case bush	Standard 0.025 – 0.089 mm (0.0010 – 0.0035 in.)	Service limit 0.2 mm (0.0078 in.)

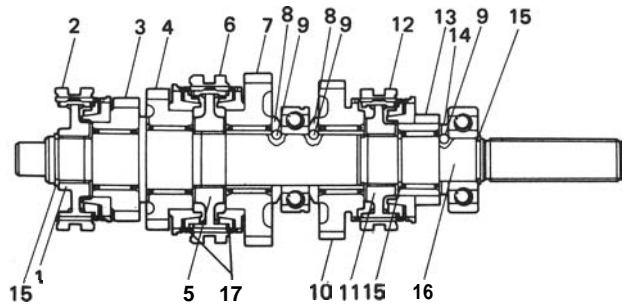
## 13-6. IMPORTANT STEPS IN INSTALLATION

### NOTE:

- Before installation, wash each part and apply specified gear oil to sliding faces of bearing and gear.
- Use new circlips on shaft for reinstallation. Don't reuse used circlips.
- Tighten each fastening bolt and nut according to specified torque data listed on the last page of this section.

### Main Shaft and Input Shaft

Install each parts by reversing respective removal procedures. Be careful for installing direction of each washer, gear, synchronizer hub and sleeve. Refer to figure below. Make sure to install each ball on main shaft.



- |                                   |                                 |
|-----------------------------------|---------------------------------|
| 1. High speed synchronizer hub    | 6. Washer                       |
| 2. High speed synchronizer sleeve | 9. Ball                         |
| 3. 3rd gear                       | 10. Reverse gear                |
| 4. 2nd gear                       | 11. Reverse synchronizer hub    |
| 5. Low speed synchronizer hub     | 12. Reverse synchronizer sleeve |
| 6. Low speed synchronizer sleeve  | 13. 5th gear                    |
| 7. Low gear                       | 14. 5th gear washer             |
|                                   | 15. Circlip                     |
|                                   | 16. Main shaft                  |
|                                   | 17. Spring                      |

Fig. 13-4 1

1) Install 2nd gear bearing, 2nd gear, spring, synchronizer ring and low speed synchronizer hub/sleeve onto main shaft, using care for installing direction of synchronizer sleeve.

After putting on each synchronizer, be sure that 3 keys mounted on hub fit snugly into slots cut in ring.

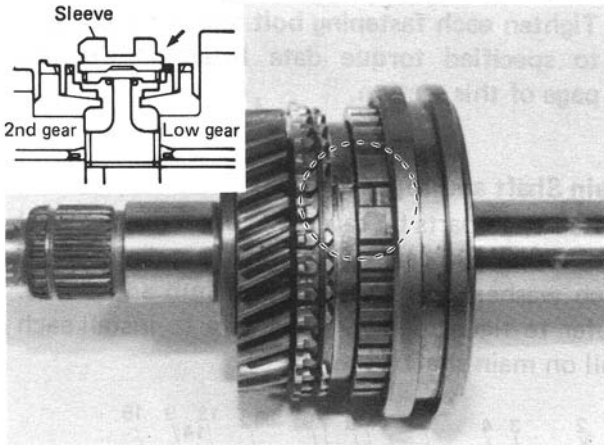


Fig. 13-42

Then using hydraulic press, press-fit low gear bush. 2 bushes on main shaft are the same.  
Bearing installer (D) (09925-18010)

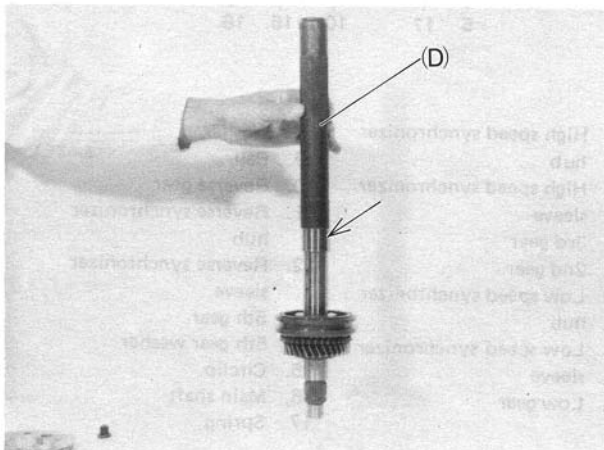


Fig. 13-43

2) Install low gear needle bearing, spring, synchronizer ring, low gear, ball and washer onto main shaft.

Fit ball into hole in shaft and install washer so that its slot ① comes over ball ③.

To direct washer correctly, bring its circumference chamfered side ② to main shaft center bearing.

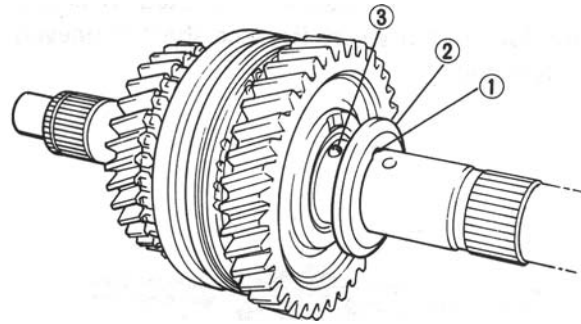


Fig. 13-44

3) Press-fit center bearing with bearing installer (special tool) using care for its installing direction.

Bearing installer (D) (09925-18010)

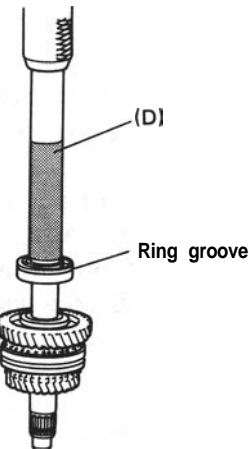


Fig. 13-45

4) Install ball and washer.

As figure shows, install washer so that its circumference chamfered side faces center bearing ① and its slot ② comes over ball ③.

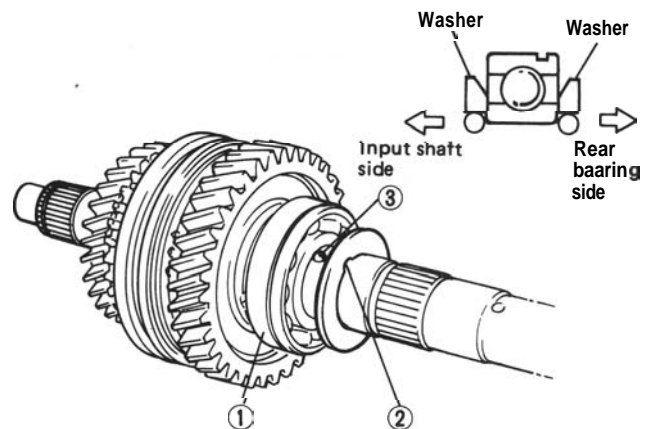


Fig. 13-46

- 5) Press-fit reverse gear bush, preventing ball installed in step 4) from coming off.  
 Bearing installer (D) (09925-I 8010)

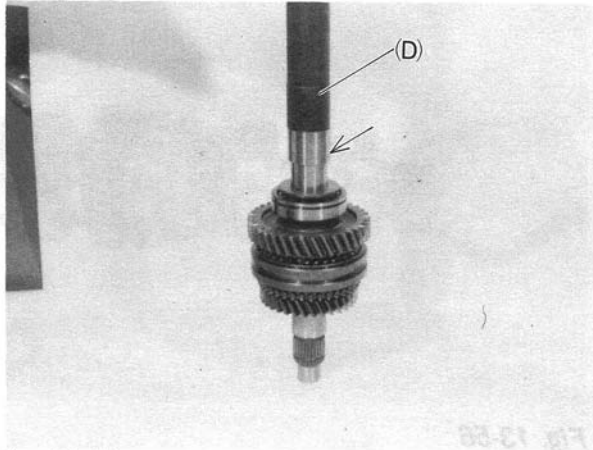


Fig. 13-47

- 6) Install reverse gear bearing, reverse gear and reverse synchronizer hub/sleeve. For proper direction, make sure to install hub so that the side whose inside boss ① is smaller in diameter and longer is directed to main shaft rear bearing, and sleeve so that the side whose inside is stepped ② is also directed to main shaft rear bearing.

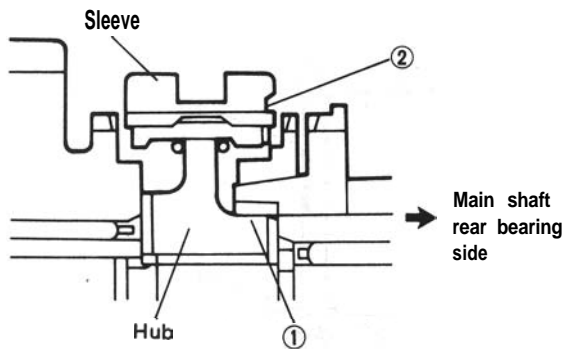


Fig. 13-48

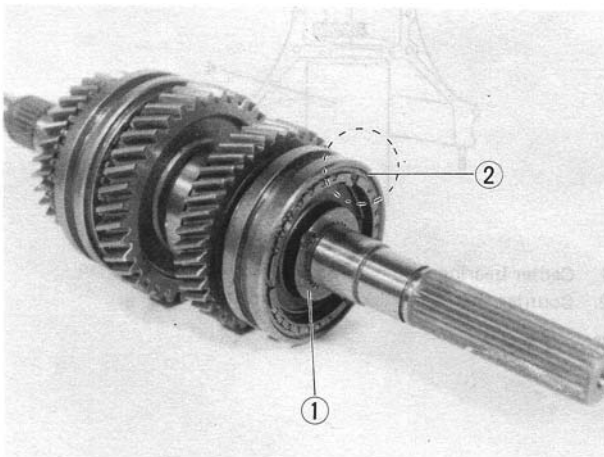


Fig. 1349

- 7) Fit reverse hub circlip into groove in main shaft.

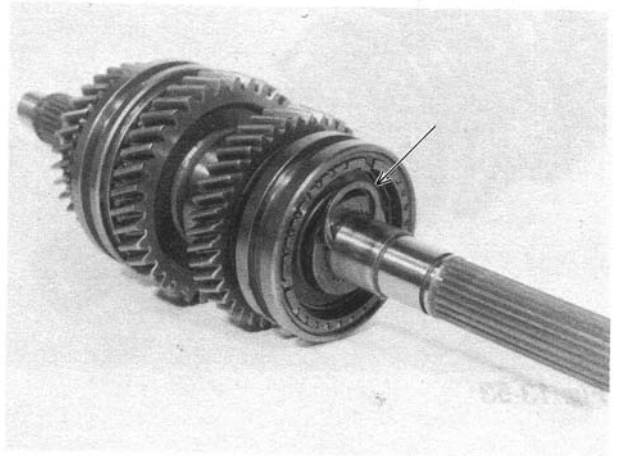


Fig. 13-50

- 8) Install 5th gear bearing, 5th gear synchronizer ring and 5th gear. Then install ball and washer, making oil groove of washer face 5th gear.

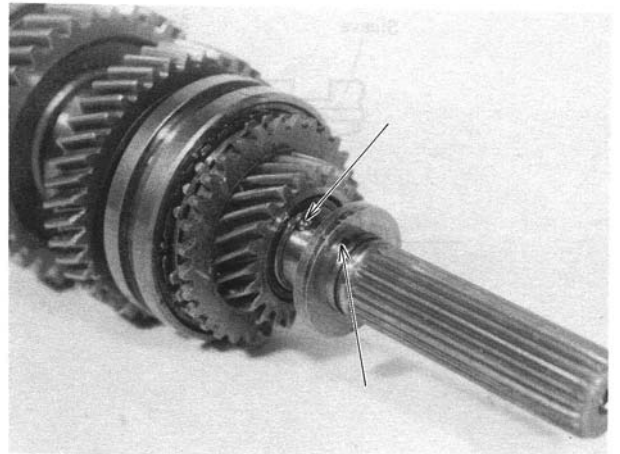


Fig. 13-51

- 9) Press-fit main shaft rear bearing and fit circlip into groove in main shaft.  
 Bearing installer (D) (09925-18010)

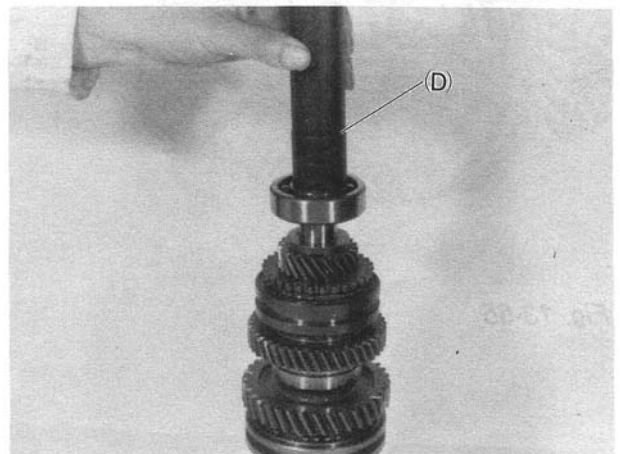


Fig. 13-52

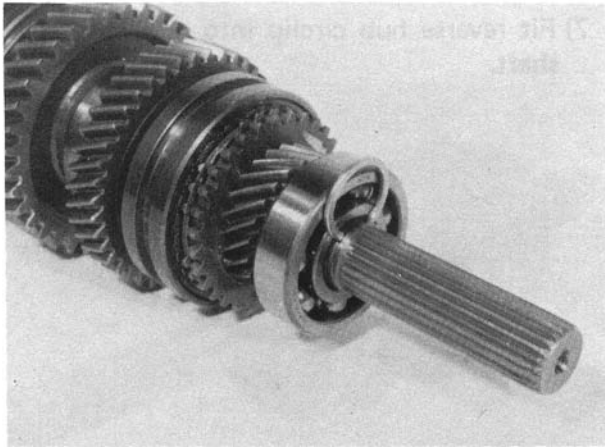


Fig. 13-53

10) Install 3rd gear bearing, 3rd gear, high speed synchronizer ring and hub/sleeve. When installing hub, direct the side with larger outer diameter boss to 3rd gear side. Then fit circlip into groove in main shaft.

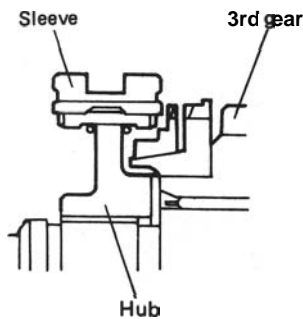


Fig. 13-54

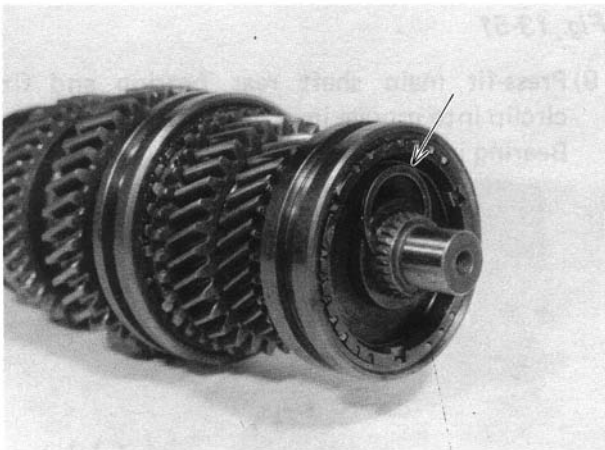


Fig. 13-55

11) Install synchronizer ring, needle bearing and input shaft.

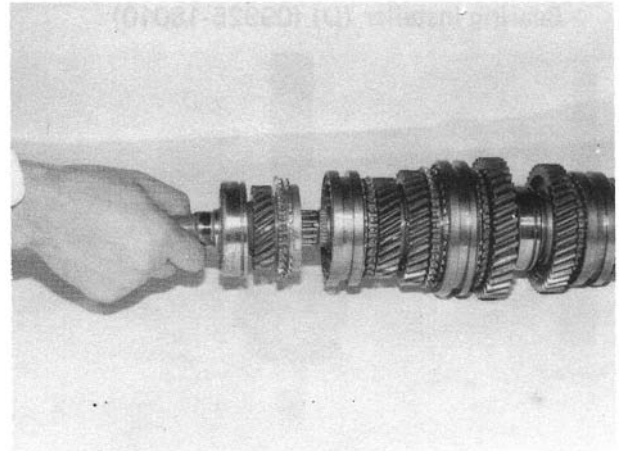
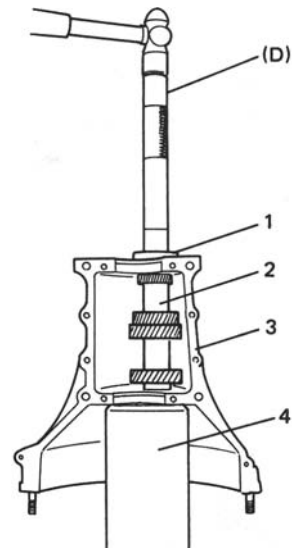


Fig. 13-56

#### Counter Shaft and Reverse Idle Gear

1) Drive counter shaft front bearing into lower case. Then using plastic hammer, drive counter shaft into front bearing a little. In the above state, using bearing installer (special tool), drive center bearing onto counter shaft and into lower case.

Bearing installer (D) (09925-18010)



1. Center bearing  
2. Counter shaft

3. Transmission lower case  
4. Wood stand

Fig. 13-57

2) Fit counter shaft front circlip into groove in shaft.

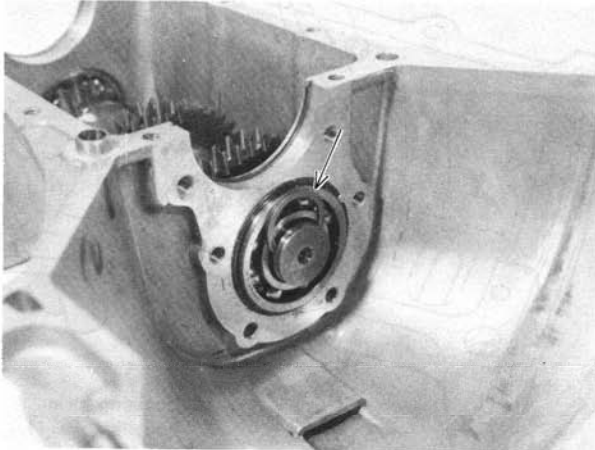


Fig. 13-58

3) Install counter shaft reverse gear and 5th gear onto counter shaft. And then drive counter shaft rear bearing onto it.

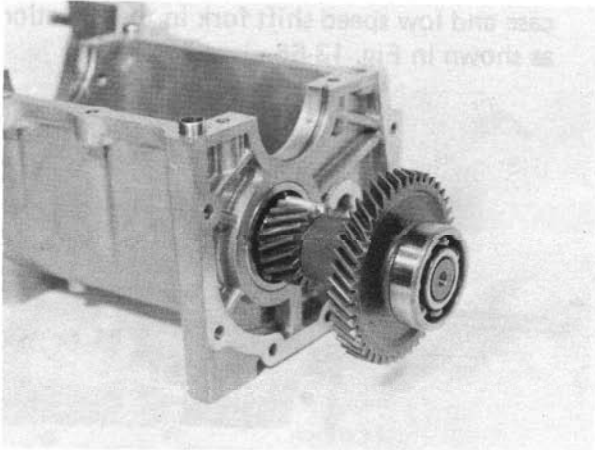


Fig. 13-59

4) Install idle gear and washer onto reverse gear shaft and pin into it. Install above as assembled into lower case with pin ① and washer tongue ② aligned as shown below.

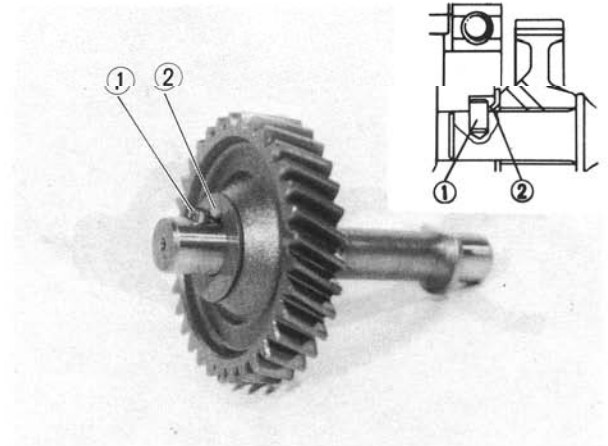


Fig. 13-60

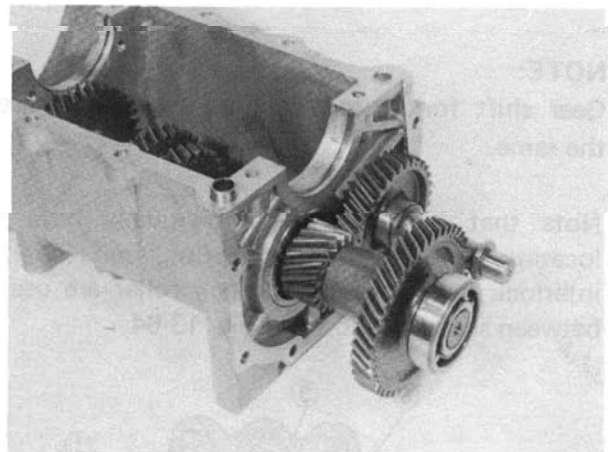


Fig. 13-61

### Shifter Forks, Shafts and Yokes [Forks and Shafts]

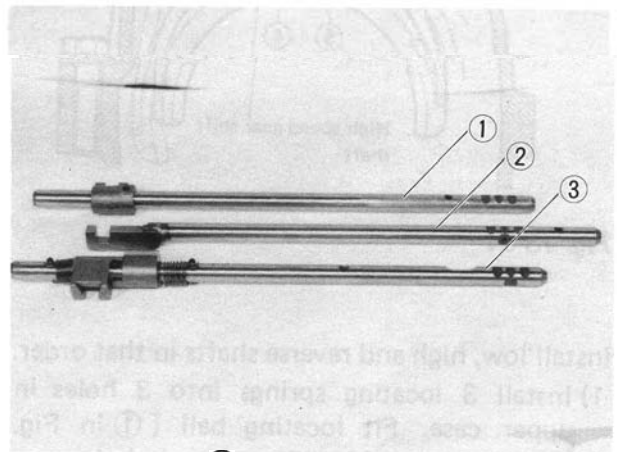
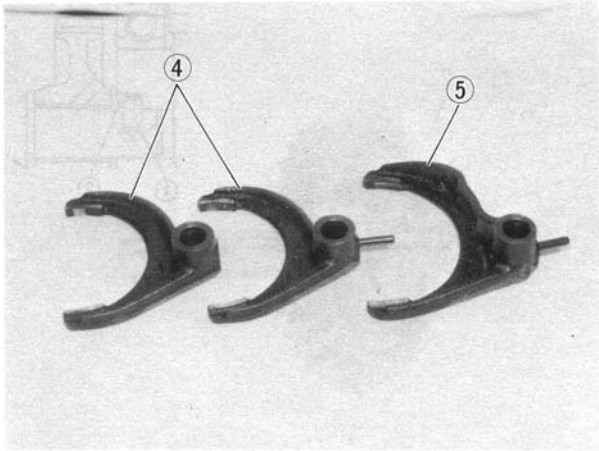


Fig. 13-62

- ① Low speed gear shift shaft
- ② High speed gear shift shaft
- ③ Reverse gear shift shaft



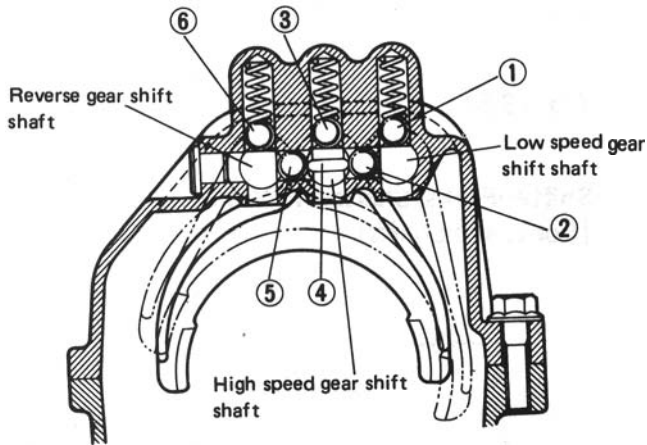


**Fig. 13-63** ④ High and reverse gear shift fork  
⑤ Low speed gear shift fork

**NOTE:**

Gear shift forks used for high and reverse are the same.

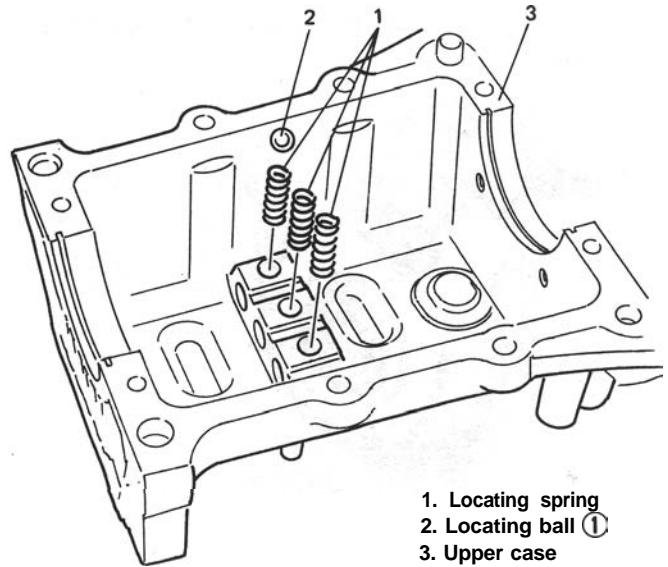
Note that 3 shift shafts individually have a locating ball and locating spring, and that 2 interlock balls and an interlock roller are used between shafts as shown in Fig. 13-64.



**Fig. 13-64**

Install low, high and reverse shafts in that order.

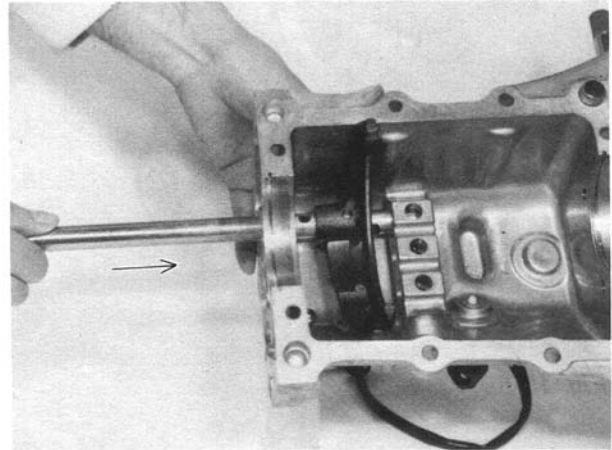
- 1) Install 3 locating springs into 3 holes in upper case. Fit locating ball (① in Fig. 13-64) on top of locating spring in hole.



**Fig. 13-65**

1. Locating spring
2. Locating ball ①
3. Upper case

- 2) Insert low speed gear shift shaft into upper case and low speed shift fork in the direction as shown in Fig. 13-66.



**Fig. 13-66**

- 3) As shown below, push down low speed gear shift shaft locating ball to pass shaft over it and keep inserting shaft until locating ball fits in center slot of 3 continuous slots in shaft.  
Drive shift yoke pin into fork and shaft.



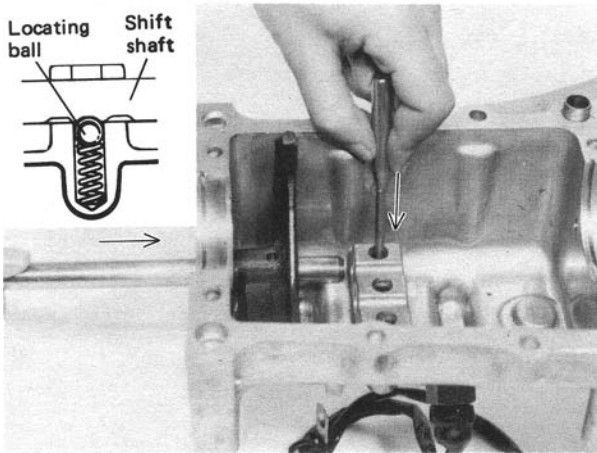


Fig. 13-67

- 4) Install interlock ball (② in Fig. 1364) and locating ball (③ in Fig. 13-64) in upper case. After installing interlock roller (④ in Fig. 1364) in high speed gear shift shaft and insert shaft into upper case as described in 2) and 3).

Fork should be installed in such direction as shown in Fig. 13-68. Then drive shift yoke pin until it becomes flush with outer surface of fork.

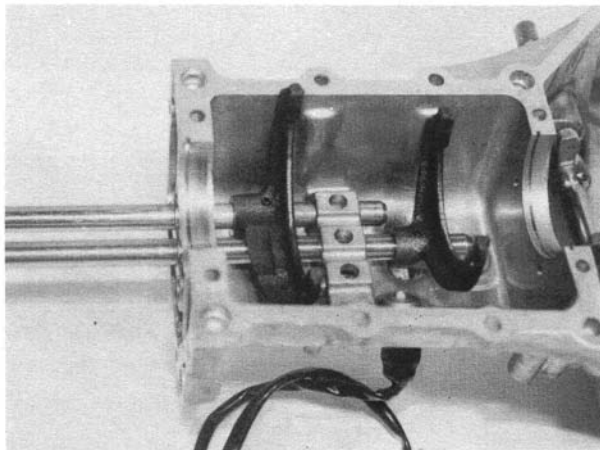


Fig. 13-68

- 5) Install interlock ball (⑤ in Fig. 1364) and locating ball (⑥ in Fig. 13-64) into upper case. Then insert reverse gear shift shaft into upper case as described in 2) and 3).

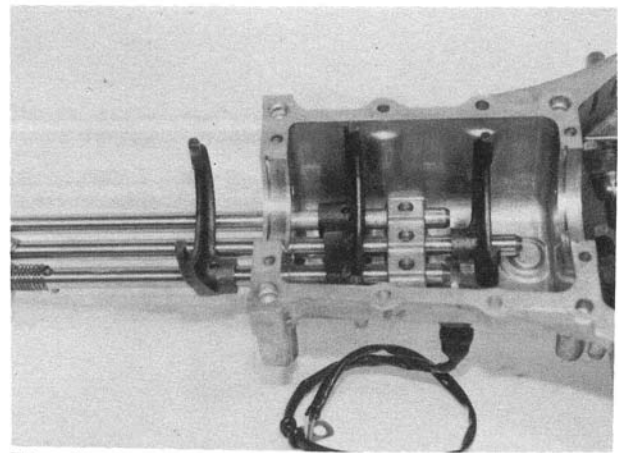


Fig. 13-69

### [Yokes]

- 1) Install low speed gear shift yoke as shown below, using care for its direction.

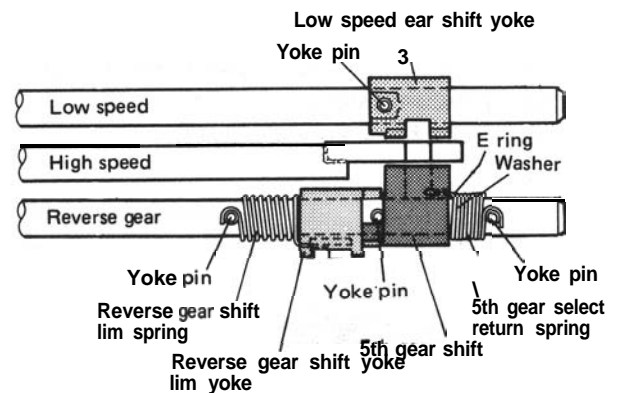


Fig. 13-70

- 2) Install reverse gear shift yoke and 5th gear shift yoke as shown below. Use care for installing direction of each part. Between 2 springs, shorter one is 5th select return spring.

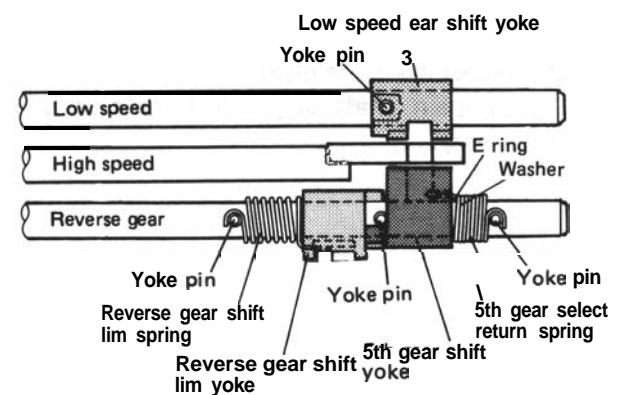
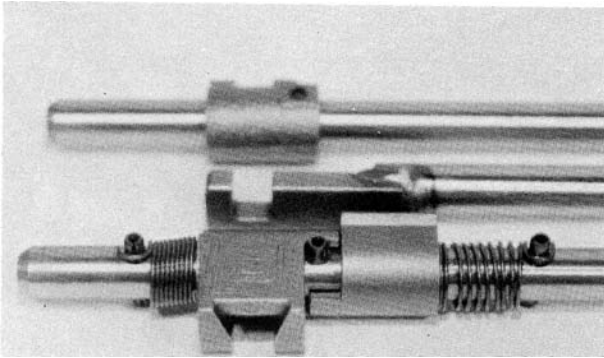
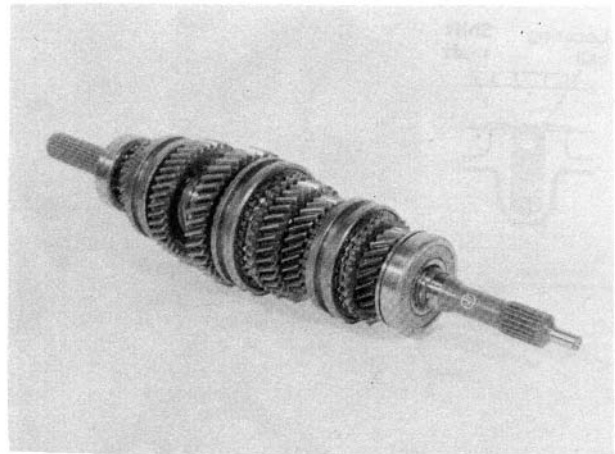


Fig. 13-71



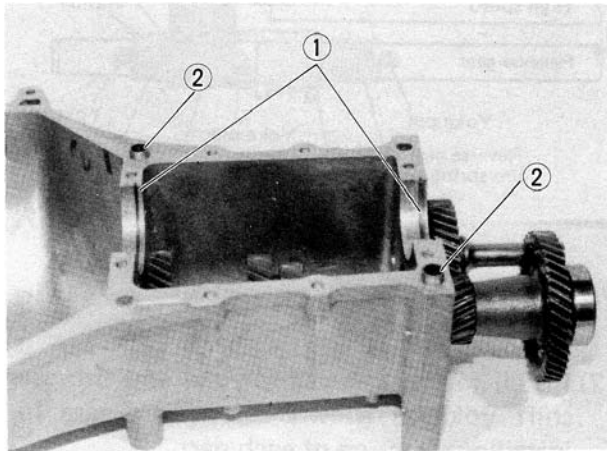
**Fig. 13-72**



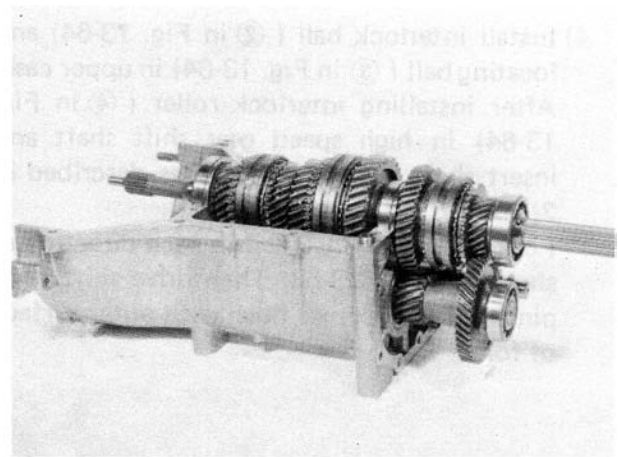
**Fig. 13-74 Main shaft and input shaft assembly**

**Transmission Lower Case and Upper Case**

- 1) With counter shaft ass'y, reverse idle gear and reverse gear shaft installed in lower case, check to ensure that bearing stopper rings ① are fitted in both sides of lower case as shown below. Also check for 2 knock pins ②.

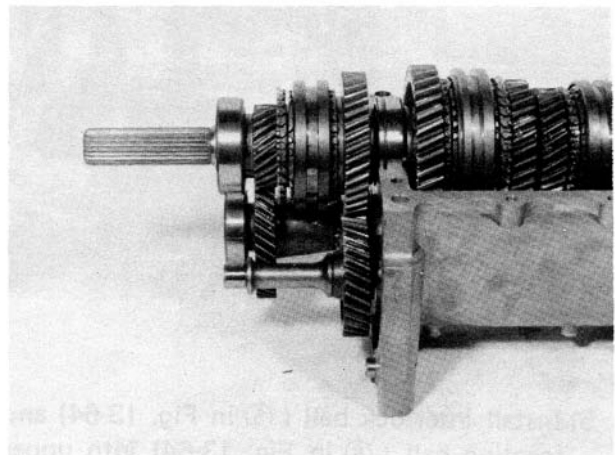


**Fig. 13-73**



**Fig. 13-75**

- 2) Make sure that mating surfaces of both lower and upper cases are clean.
- 3) Install main shaft and input shaft ass'y in lower case.



**Fig. 13-76**

- 4) Uniformly apply sealant (SUZUKI BOND NO. 1215, 99000-31110) to mating surface of lower case.

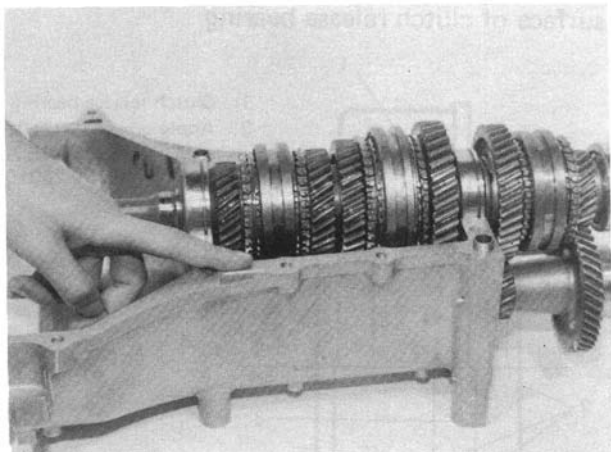


Fig. 13-77

- 5) Install upper case to lower case by matching 3 shift forks with 3 grooves in synchronizer sleeve on main shaft respectively.

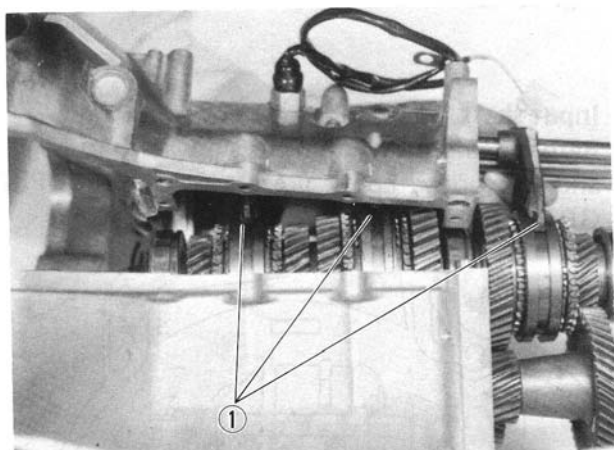


Fig. 13-78 ① Shift forks

- 6) Tighten case bolts to specification.

Tightening torque for transmission case bolts	N·m	kg·m	lb·ft
	18 - 28	1.8 - 2.8	13.5 - 20.0

Extension Case

- 1) Check to ensure that knock pins ① are fitted.

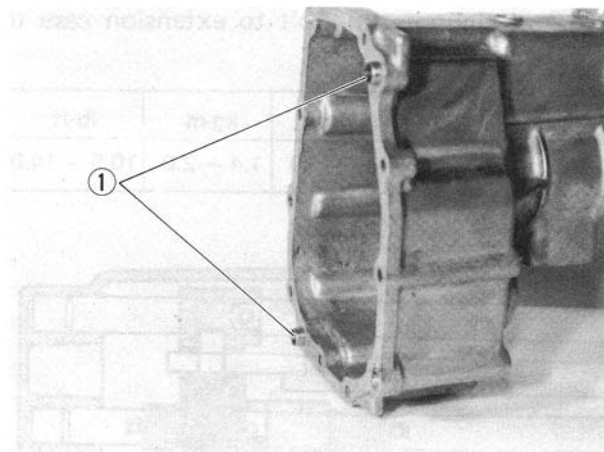


Fig. 13-79

- 2) Apply grease (SUZUKI SUPER GREASE A 99000-25010) to oil seal lip.

- 3) Clean surface of extension case to mate with transmission case and uniformly apply sealant (SUZUKI BOND No. 1215, 99000-31110).

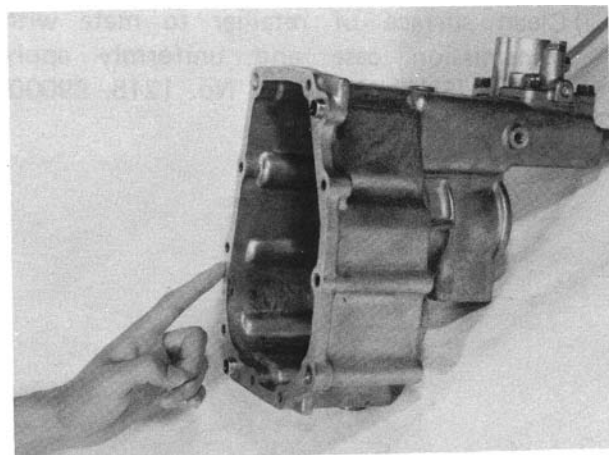


Fig. 13-80

- 4) Make sure that 3 shift shafts are in neutral position as shown in Fig. 13-23.

- 5) Install extension case to transmission case.  
6) Tighten case bolts to specification.

Tightening torque for extension case bolts	N·m	kg·m	lb·ft
	18 - 28	1.8 - 2.8	13.5 - 20.0

7) Apply thread lock agent (THREAD LOCK CEMENT SUPER "1333B" 99000-32020) to thread of reverse gear shift rim bolt, And tighten rim bolt to extension case to specified torque.

Tightening torque for reverse gear shift rim bolt	N·m	kg·m	lb-ft
	14 - 20	1.4 - 2.0	10.5 - 14.0

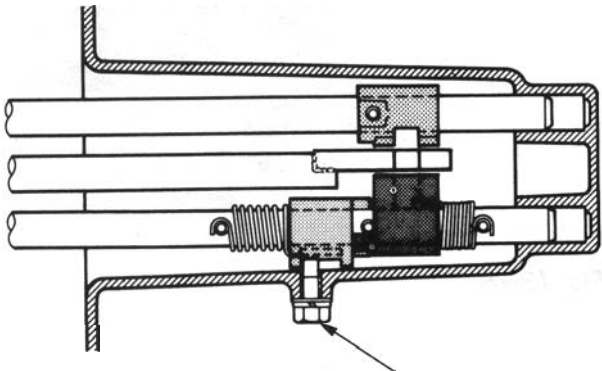


Fig. 13-81

#### Input Shaft Bearing Retainer

- 1) Apply grease (SUZUKI SUPER GREASE A 99000-25010) to oil seal lip.
- 2) Clean surface of retainer to mate with transmission case and uniformly apply sealant (SUZUKI BOND No. 1215, 99000-31110).

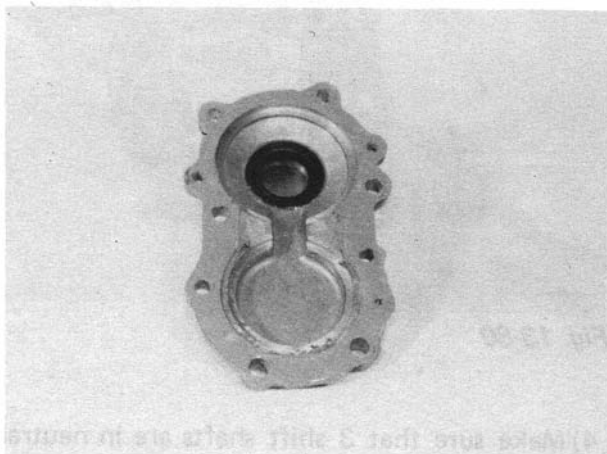


Fig. 13-82

- 3) Tighten retainer bolts to specification.

Tightening torque for retainer bolts	N·m	kg - m	lb-ft
	18 - 28	1.8 - 2.8	13.5 - 20.0

- 4) Check transmission input shaft for easy rotation by hand.
- 5) Check each select and shift shaft for operation.

#### Clutch Release Bearing

Before installing bearing, apply grease (SUZUKI SUPER GREASE A 99000-25010) to inner surface of clutch release bearing.

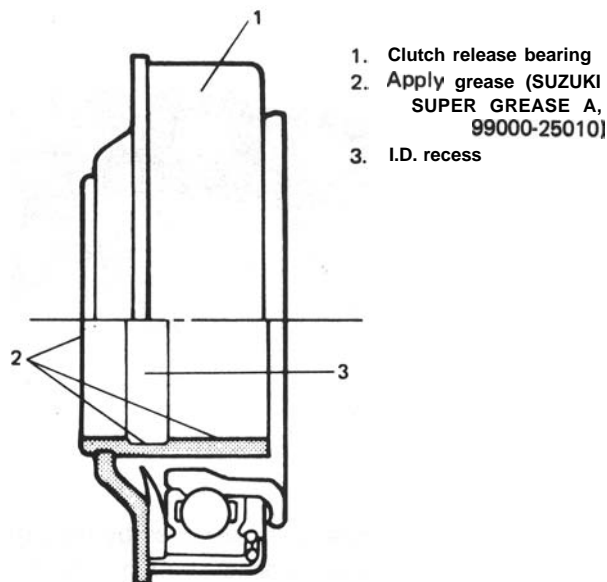


Fig. 13-83

#### Input shaft

Before remounting transmission ass'y to engine and car body, apply grease (SUZUKI SUPER GREASE I, 99000-25210) to input shaft.

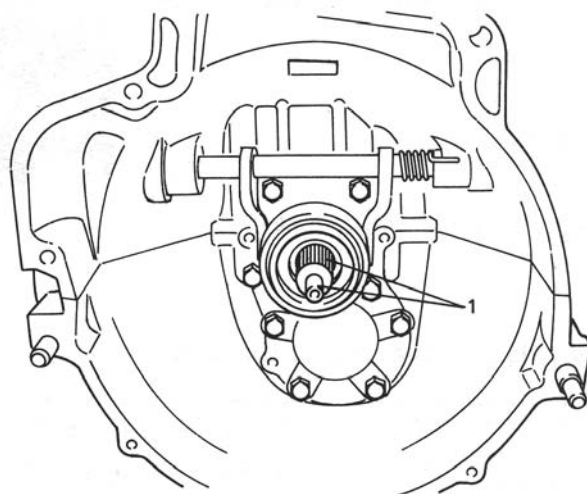


Fig. 13-84

1. Apply grease

#### Others

Upon completion of reassembly and installation of transmission ass'y in car body, pour specified amount of transmission oil into transmission, and check carefully for oil leakage. Refer to p. 13-25 for oil to be used and specified amount.

## 13-7. MAINTENANCE SERVICES

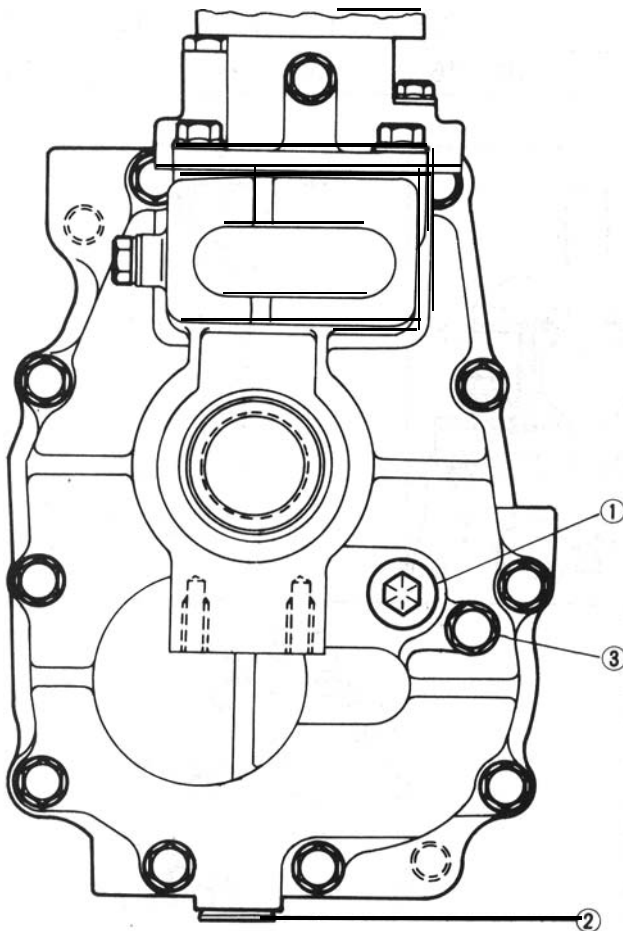
### Transmission Oil

Before changing oil, check for oil leakage first and correct defects, if any. Fill specified new oil in specified amount.

Oil capacity	1.3 litres (2.75/2.29 US/Imp. pt.)
Oil specification	Gear oil, SAE 80W-90, 75W-80 or 75W-90

It is highly recommended to use SAE 75W-90 gear oil.

For viscosity chart, refer to P. I-20.



- ① Oil filler plug
- ② Oil drain plug
- ③ Oil level plug

Fig. 13-85

After filling transmission with oil, torque oil filler and drain plugs to specification.

Tightening torque for oil drain and filler plug	N·m	kg·m	lb·ft
	18-28	1.8-2.8	13.5-20.0
Tightening torque for oil level plug	10-16	1.0-1.6	7.5-11.5

### NOTE:

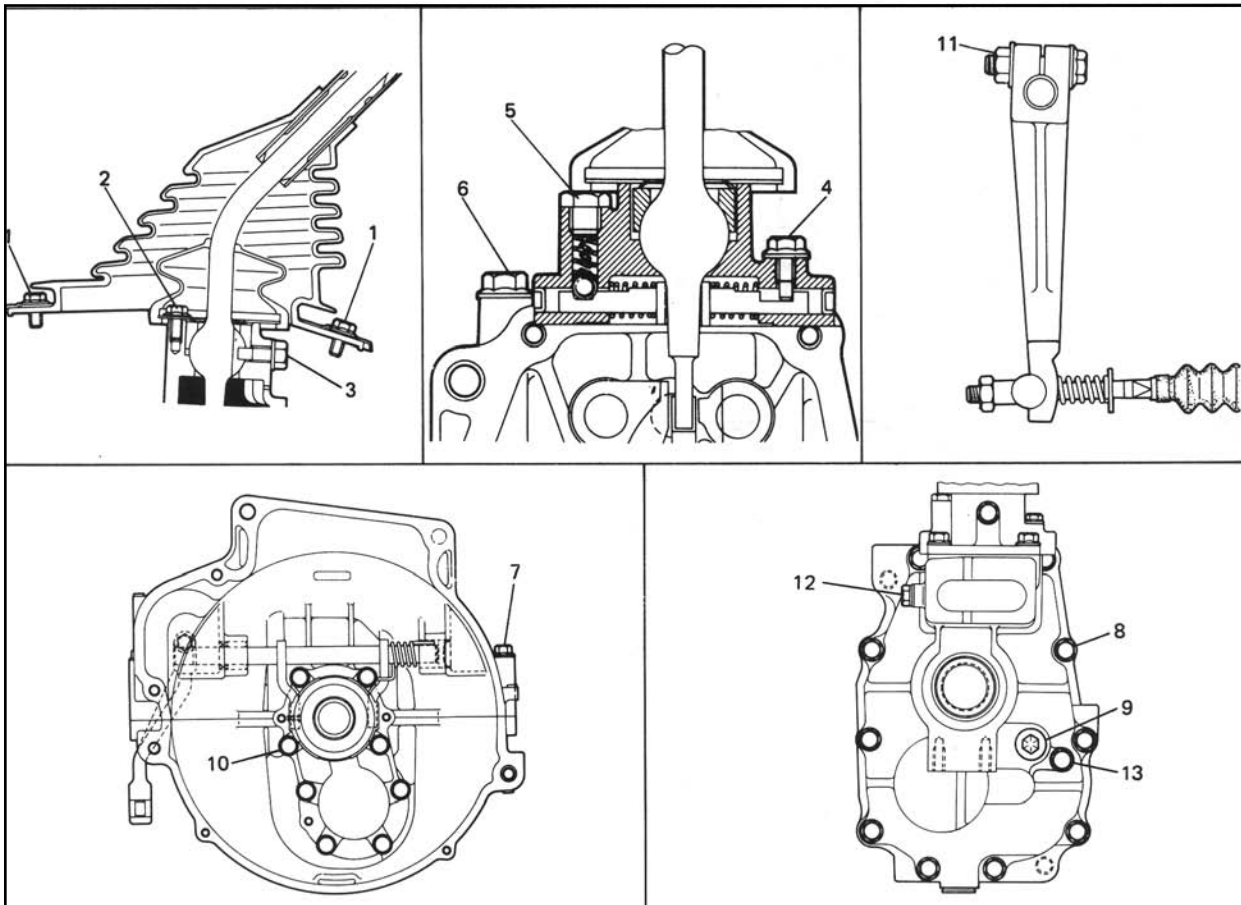
Whenever car was hoisted for any other service work than oil change, also be sure to check for oil leakage.

When installing oil drain and filler plugs to transmission case, apply sealant (SUZUKI BOND No.1215, 99000-31110) to thread part of plug.

### 13-8. RECOMMENDED TORQUE SPECIFICATION

Be sure to torque each bolt and nut according to specification given below, whenever loosened.  
If specified torque for particular bolt or nut is not included in the list, refer to page O-13.

System	Fastening parts	Tightening torque		
		N·m	kg·m	lb·ft
Gear shifting control	1. Gear shift control boot cover bolt	4 – 7	0.4 – 0.7	3.0 – 5.0
	2. Gear shift lever case cover bolt	4 – 7	0.4 – 0.7	3.0 – 5.0
	3. Control lever locating bolt	14 – 20	1.4 – 2.0	10.5 – 14.0
	4. Low speed select pin bolt	4 – 7	0.4 – 0.7	3.0 – 5.0
	5. Reverse select pin screw	25 – 35	2.5 – 3.5	18.5 – 25.0
	6. Gear shift lever case bolt	18 – 28	1.8 – 2.8	13.5 – 20.0
Transmission	7. Transmission case bolt	18 – 28	1.8 – 2.8	13.5 – 20.0
	8. Extension case bolt	18 – 28	1.8 – 2.8	13.5 – 20.0
	9. Transmission oil filler and drain plug	18 – 28	1.8 – 2.8	13.5 – 20.0
	10. Input shaft bearing retainer bolt	18 – 28	1.8 – 2.8	13.5 – 20.0
	11. Clutch release arm nut	10 – 16	1.0 – 1.6	7.5 – 11.5
	12. Reverse gear shift rim bolt	14 – 20	1.4 – 2.0	10.5 – 14.0
	13. Transmission oil level plug	10 – 16	1.0 – 1.6	7.5 – 11.5



## SECTION 14

# TRANSFER GEAR BOX

### CONTENTS

14-1.	GENERAL DESCRIPTION .....	14-2
14-2.	SELECTIVE FLOWS OF TRANSFER DRIVE .....	14-3
14-3.	GEAR RATIO DATA .....	14-4
14-4.	TRANSFER SERVICES NOT REQUIRING TRANSFER REMOVAL ....., .....	14-5
14-5.	REMOVAL .....	14-6
14-6.	DISASSEMBLY .....	14-8
14-7.	INSPECTION OF COMPONENTS .....	14-12
14-8.	REASSEMBLY .....	14-14
14-9.	MAINTENANCE SERVICES .....	14-22
14-10.	TIGHTENING TORQUE .....	14-23







## 14-2. SELECTIVE FLOWS OF TRANSFER DRIVE

### 2-Wheel Drive (Rear-Wheel Drive)

Rear shifter fork pushes rear clutch sleeve into "high" gear, thus coupling the gear to output rear shaft.

Drive flows from input shaft to output rear shaft through big gear, "high" gear and rear clutch.

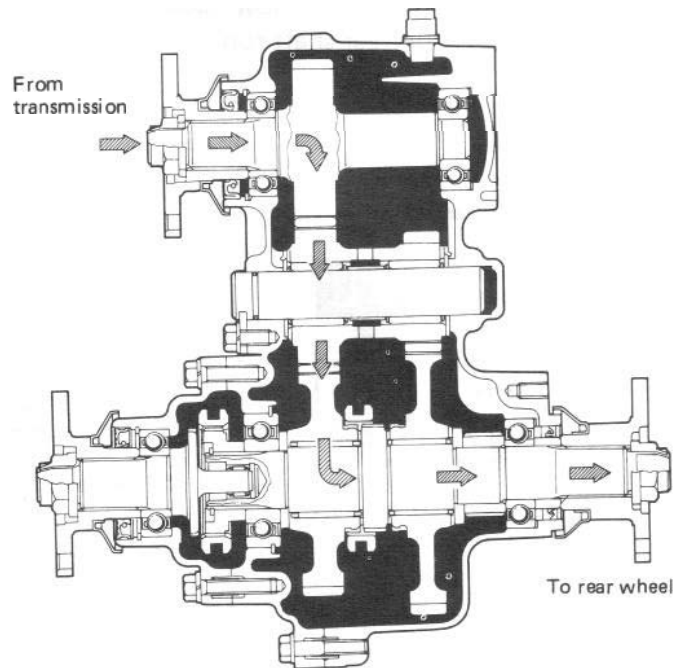
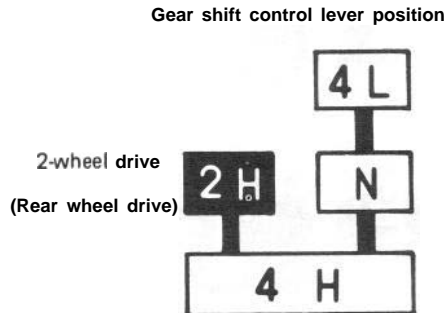


Fig. 14-2

### 4-Wheel Drive HIGH (All-Wheel Drive on HIGH)

Under the conditions of rear-wheel drive, described above, front shifter fork pushes the sleeve of front clutch onto the toothed clutch ring, thus coupling output rear shaft to output front shaft. Front shaft and rear shaft run together on HIGH.

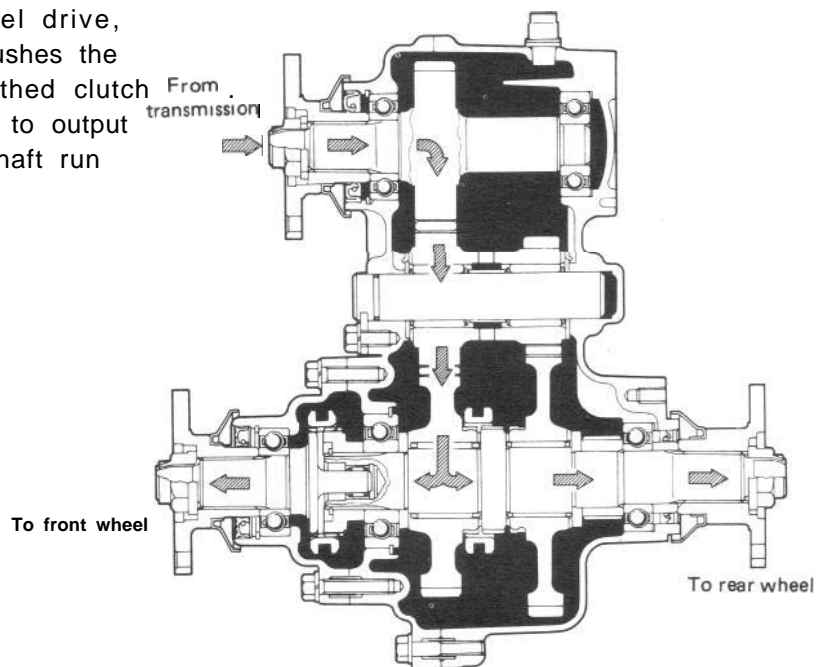
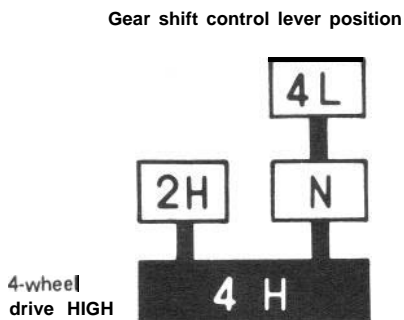


Fig. 14-3

**4-Wheel Drive LOW (All-Wheel Drive on LOW)**  
 Front shifterforkactuates front clutch to couple rear shaft to front shaft; and rear shifter fork actuates rear clutch to couple "low" gear to rear shaft. Front shaft and rear shaft run together on LOW.

Gear shift control lever position

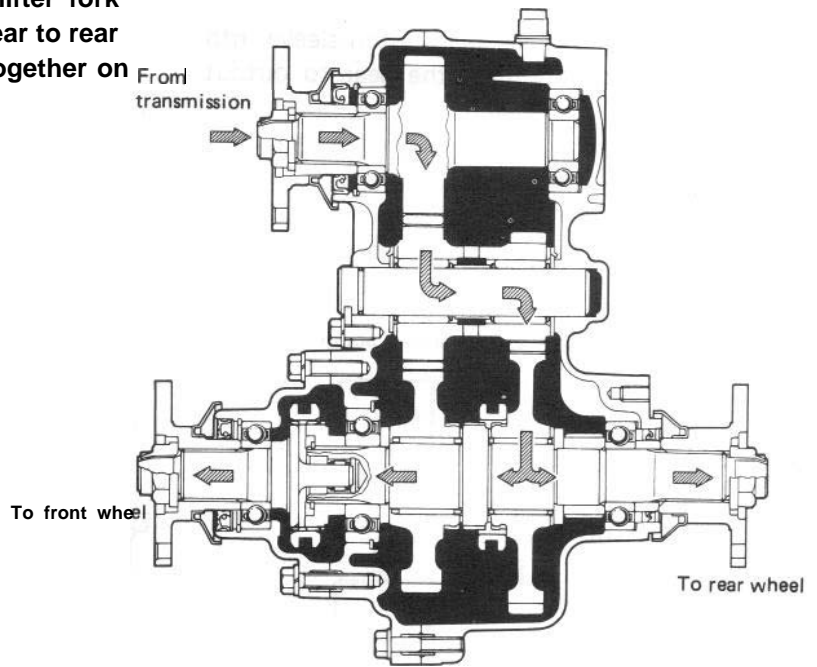
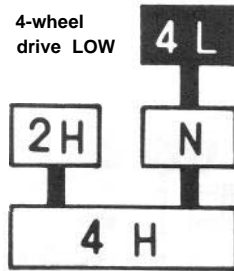


Fig. 14-4

**14-3. GEAR RATIO DATA**

Shift position	Rear-wheel drive	All-wheel drive high	All-wheel drive low
Gear	41/44 · 62/41	41/44 · 62/41	41/44 · 56/23
Reduction	1.409	1.409	2.268

#### 14-4. TRANSFER SERVICES NOT REQUIRING TRANSFER REMOVAL

Following parts or components do not require transfer removal to receive services (replacement, inspection) :

Part or Component	Nature of Service
1. Universal-joint yoke flanges	Replacement or inspection
2. Front drive shift shaft fork	Replacement or inspection
3. Transfer output front shaft oil seal	Replacement or inspection
4. Transfer output front shaft bearing	Replacement
5. Transfer output front shaft	Replacement
6. Transfer front case	Replacement
7. Front drive clutch hub	Replacement or inspection
8. Front drive clutch sleeve	Replacement or inspection
9. Transfer input shaft oil seal	Replacement
10. 4WD indicator light switch	Replacement or inspection
11. Speedometer driven gear	Replacement or inspection
12. Gear shift control lever	Replacement or inspection
13. Gear shift control boot No. 1, No. 2	Replacement
14. Gear shift control lever spring seat	Replacement or inspection

## 14-5. REMOVAL

- 1) Lift up car and remove securing bolts from each universal-joint flange connection to sever 3 propeller shafts from transfer gear box.

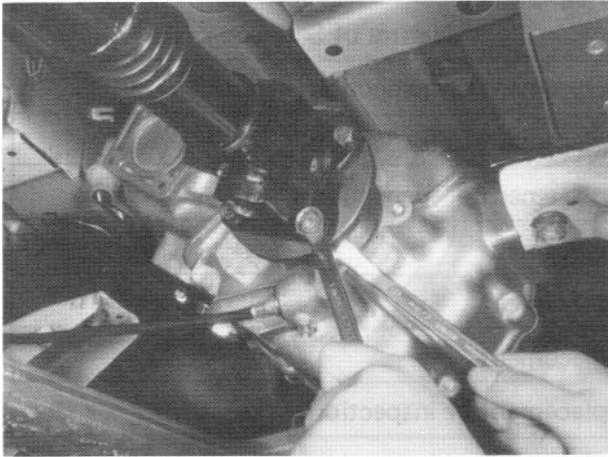


Fig. 14-5

- 2) Remove clamp ① and boot ② from transfer gear box.

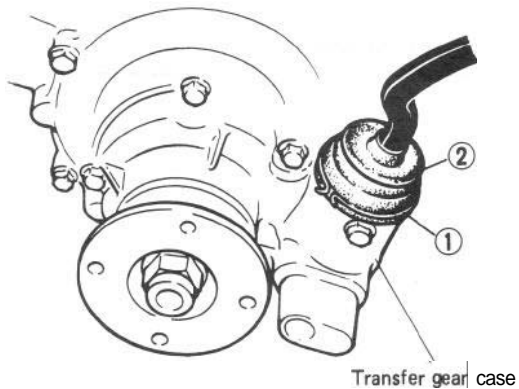


Fig. 14-6

- 3) Twist control lever guide counterclockwise while pushing it down; this will permit lever to be removed from gear box.

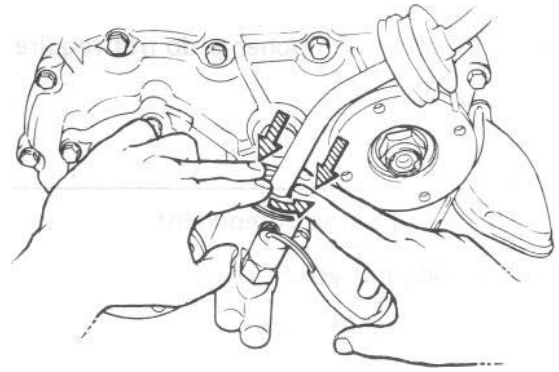


Fig. 14-7

- 4) Drain out oil from gear box by loosening its drain plug.

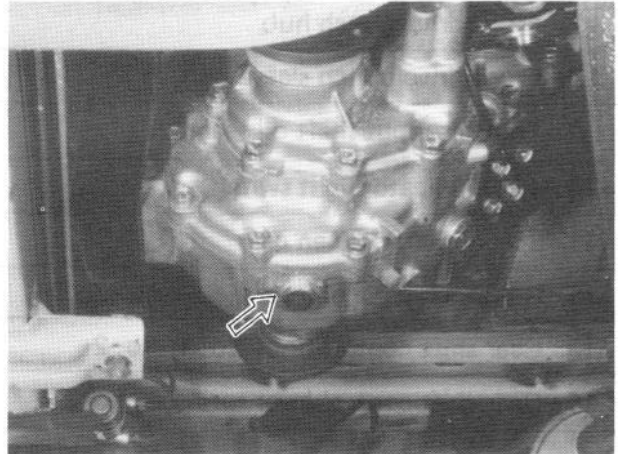


Fig. 14-8

- 5) Disconnect speedometer drive cable from transfer gear box.

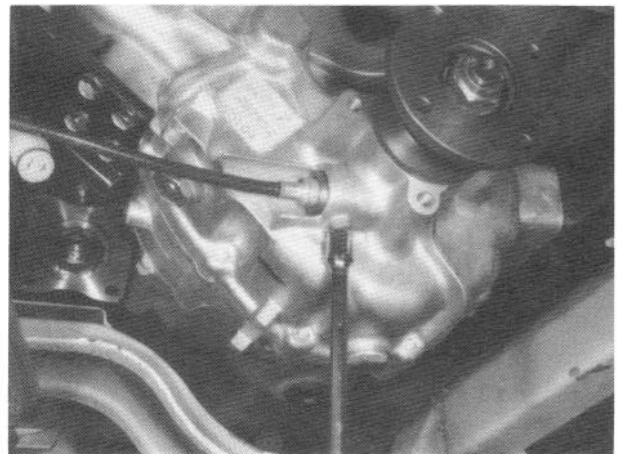


Fig. 14-9

- 6) Disconnect 4WD switch lead wire at coupler.
- 7) Remove 3 mounting nuts securing gear box to chassis, and take down gear box.

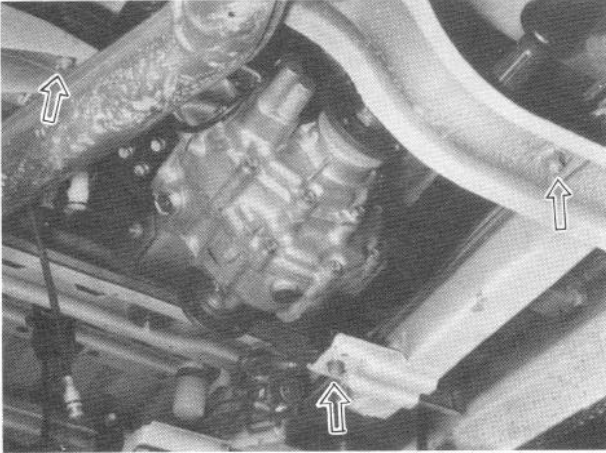


Fig. 14-11



## 14-6. DISASSEMBLY

### Universal-Joint Yoke Flanges

There are 3 flanges to be removed: one from input shaft and other from output front and rear shafts. Lock flange so that it will not turn, and loosen and remove nut holding flange to the shaft. Draw off flange.

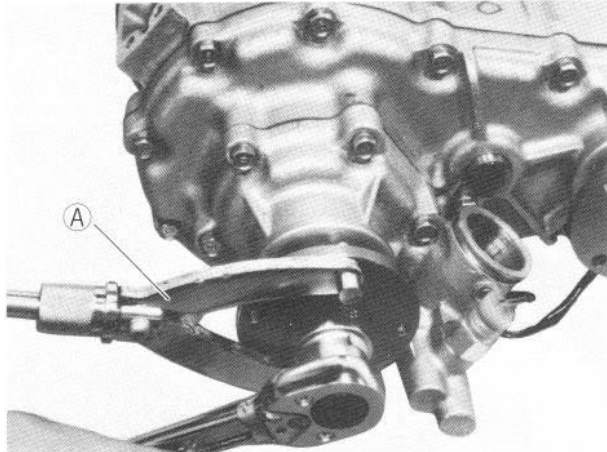


Fig. 14-12 A Special tool (09930401131)

### Speedometer Driven Gear

Loosen speedometer driven gear case bolt and remove speedometer driven gear case with gear.

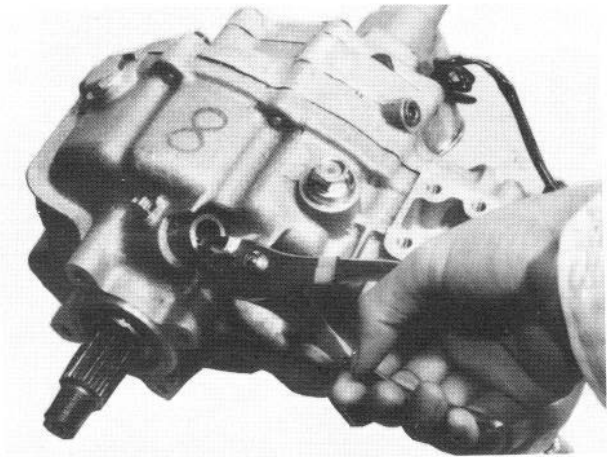


Fig. 14-15

### Transfer Front Case

Remove the indicator light switch from front case.

#### NOTE:

Use care not to lose switch ball. This ball is larger than interlock ball and locating balls.

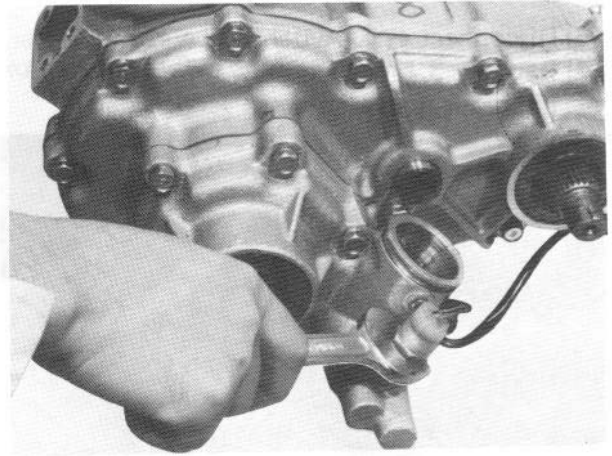


Fig. 14-16

Remove bolts securing transfer front case, and take off case.

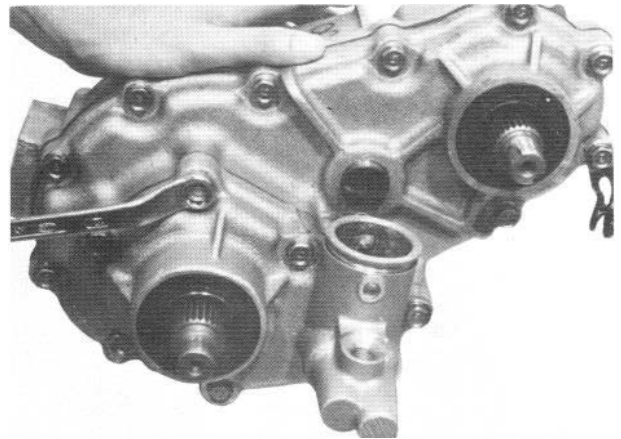


Fig. 14-17

By tapping output front shaft with a plastic hammer, remove output front shaft from front case.

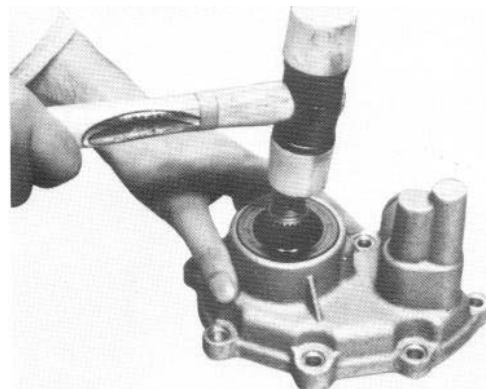
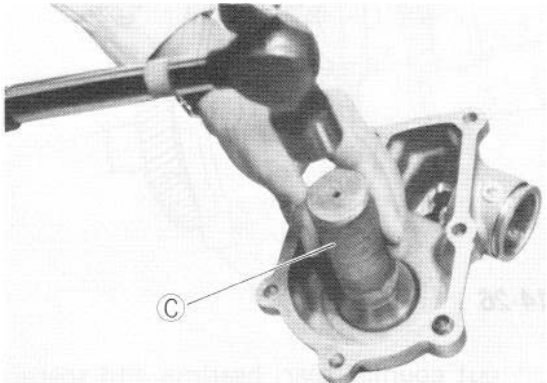


Fig. 14-18

After removing oil seal, remove circlip and drive bearing out of front case by using bearing installer (special tool).

Bearing installer ① : (09913-76010)

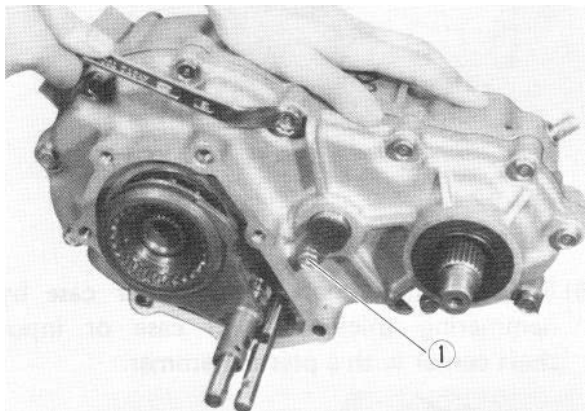


**Fig. 14-19**

#### Transfer Center Case

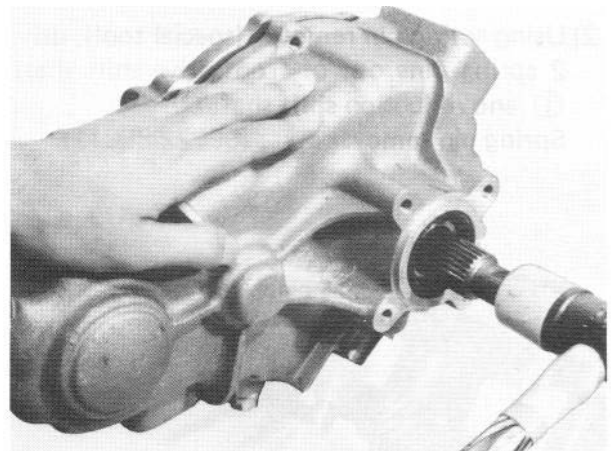
Remove bolts fastening center case and rear case together.

Do not loosen bolt ① at this point.

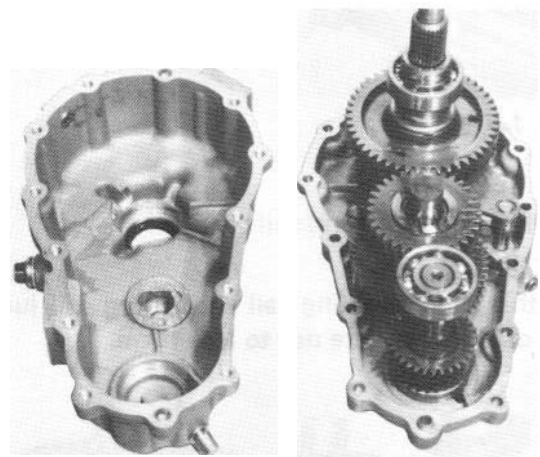


**Fig. 14-20**

By tapping rear case and output rear shaft with a plastic hammer, separate center and rear case.



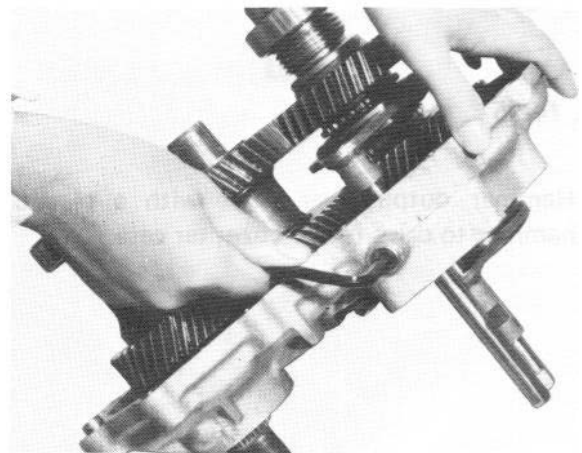
**Fig. 14-21**



**Fig. 14-22**

Given below are procedures for disassembling component parts of center case as separated from rear case.

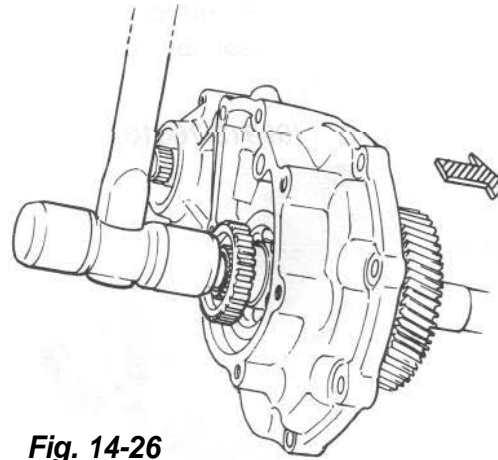
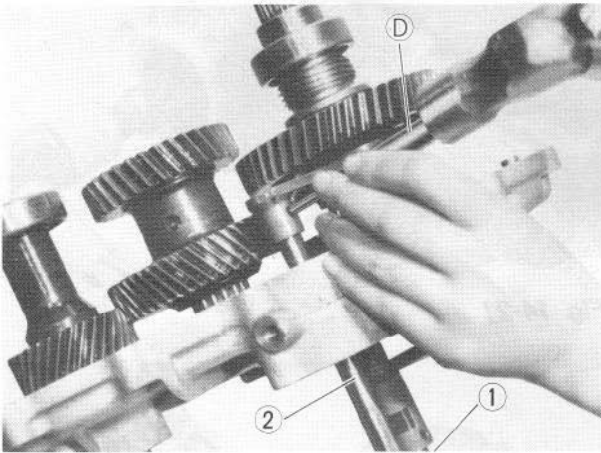
- 1) Loosen gear shift locating spring plug and take out spring and locating ball.



**Fig. 14-23**



- 2) Using spring pin remover (special tool), drive 2 spring pins out of front drive shift shaft ① and reduction shift shaft ②.  
Spring pin remover ④ : (09922-85811).



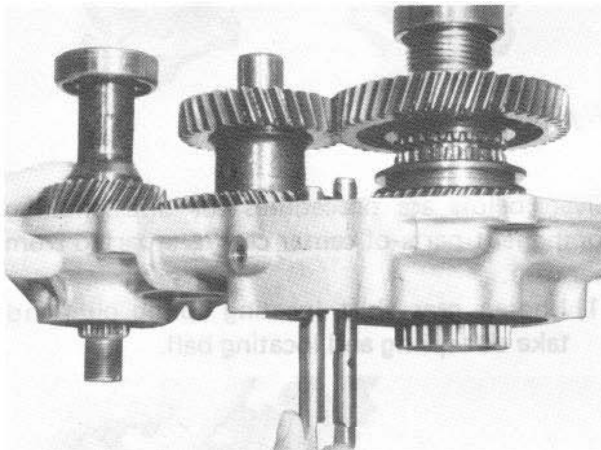
**Fig. 14-26**

- 5) Pull out counter gear, bearings and spacer. Remove counter shaft from center case by loosening counter shaft lock plate bolt.

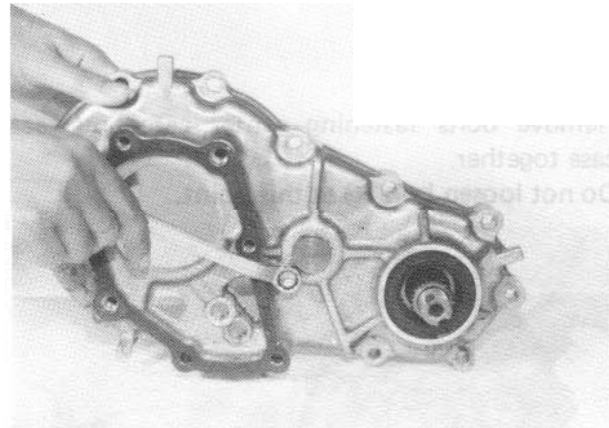
- 3) Remove forks and shift shafts.

**NOTE:**

At this time, locating ball and spring will jump out of hole, use care not to lose them.



**Fig. 14-25**



**Fig. 14-27**

- 6) Remove input shaft from center case by hammering thick part of case or input shaft center with a plastic hammer.

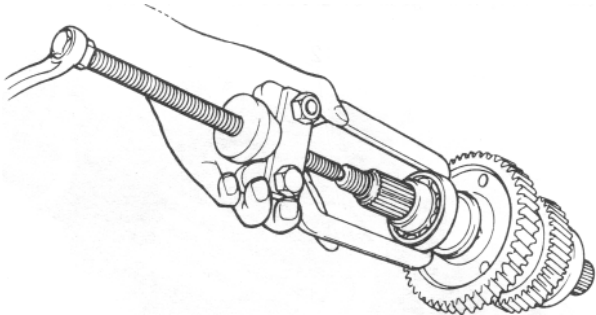
- 4) Hammer output rear shaft with a plastic hammer to drive it out of center case.



**Fig. 14-28**



- 7) Remove output shaft rear bearing and retainer together by using bearing puller. After removing bearing, speedometer drive gear, thrust washer, output low gear and needle roller bearing can be removed.

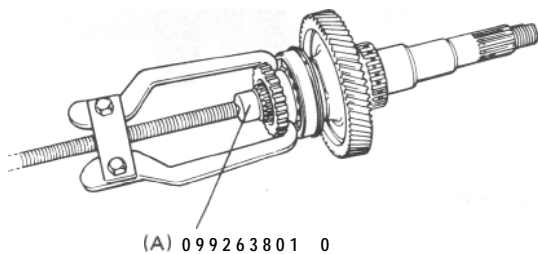


**Fig. 14-29**

- 8) Remove front drive clutch hub circlip and pull clutch hub off shaft by using bearing puller and puller attachment (special tool A).

**NOTE:**

Use care to prevent damage to needle roller bearing in output rear shaft when removing clutch hub.

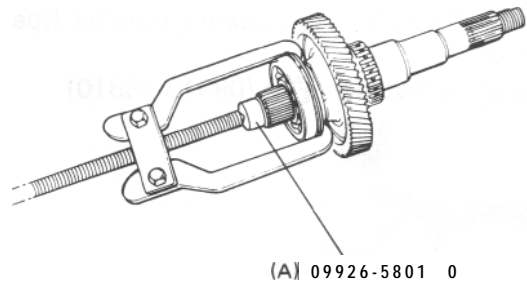


**Fig. 14-30**

- 9) Remove front bearing by using bearing puller and puller attachment (special tool A).

**NOTE:**

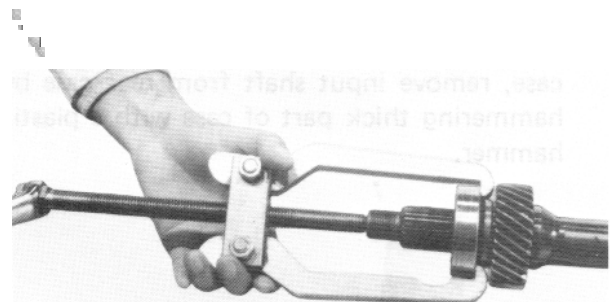
Use care to prevent damage to needle roller bearing in output rear shaft while bearing is being removed.



(A) 09926-5801 0

**Fig. 14-31**

- 10) When input shaft is removed or center case and rear case are separated, input shaft bearings may come off. In such a case, bearings can be removed from shaft by using bearing puller.



**Fig. 14-32**

11) When input shaft is removed, front bearing may be left in case. In this case, after removing oil seal and circlip, bearing can be taken out of case by using bearing installer (special tool).

Bearing installer (F) : (09913-75810)

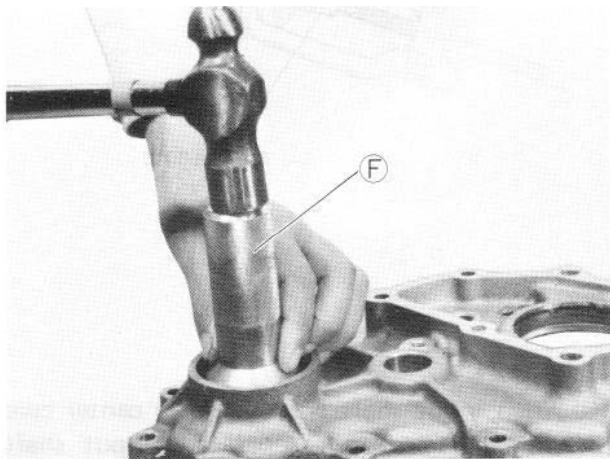


Fig. 14-33

#### Transfer Rear Case

1) When center case and rear case are separated, input shaft may be left in rear case. In this case, remove input shaft from rear case by hammering thick part of case with a plastic hammer.

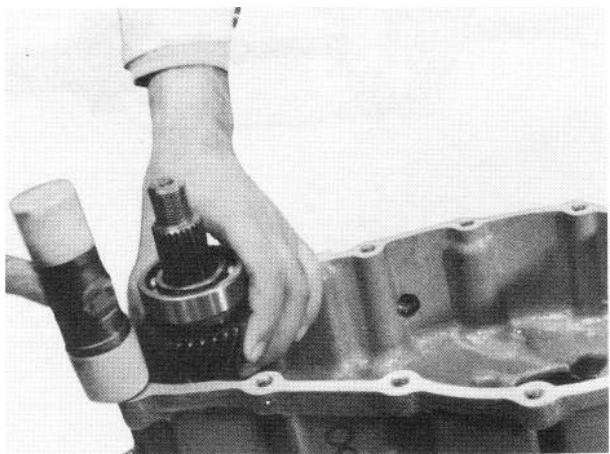


Fig. 14-34

## 14-7. INSPECTION OF COMPONENTS

### Gear Teeth

Inspect gear teeth ①, internal teeth of rear clutch sleeve ② and clutch teeth of gear 3. for wear, cracking, chipping and other malcondition. Replace gear or sleeve as necessary.

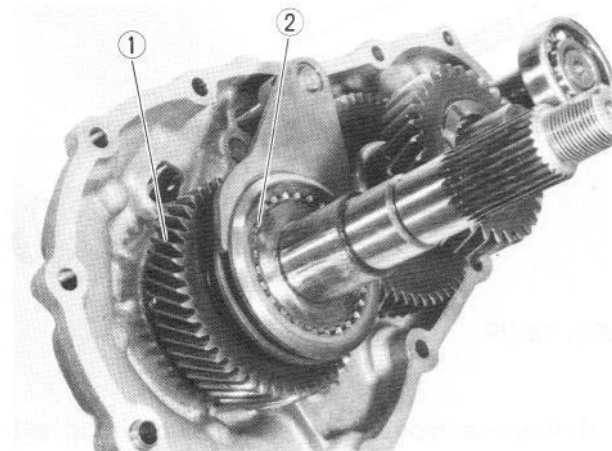


Fig. 14-35

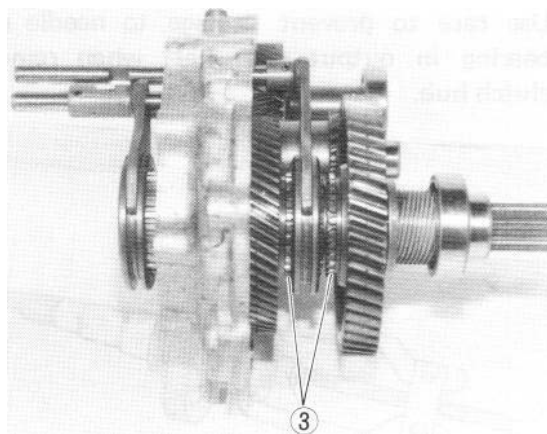
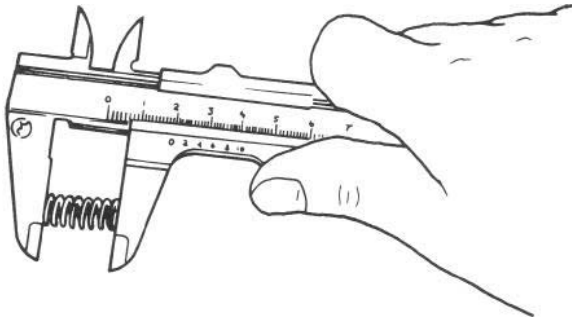


Fig. 14-36

### Locating Spring

Check each shifter fork shaft locating spring for strength by measuring its free length. If length is noted to be less than service limit, replace it.

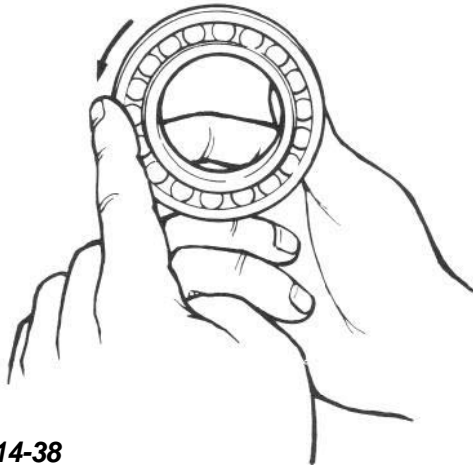
Free length of locating spring	Standard	Service limit
	23.7 mm (0.933 in)	22.0 mm (0.866 in)



**Fig. 14-37**

**Bearings**

Check each bearing by spinning its outer race by hand to “feel” smoothness of rotation. Replace bearing if noted to exhibit sticking, resistance or abnormal noise when spun or rotated by hand.

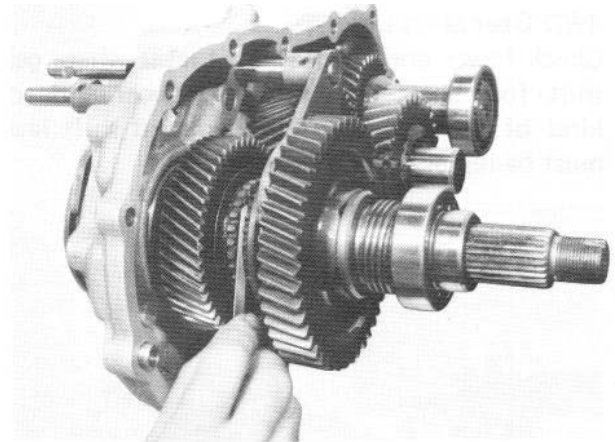


**Fig. 14-38**

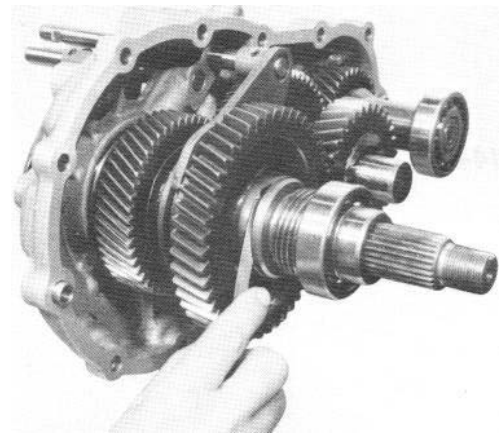
**Side Clearance of Gears**

With gear, bearing and thrust washer installed on shaft, check for side clearances of gears. If clearance exceeds service limit, replace thrust washer.

Side clearance of gear		Standard	Service limit
output gears	low gear	0.175 – 0.325mm	0.7mm (0.027in)
	high gear	(0.007 – 0.012in)	



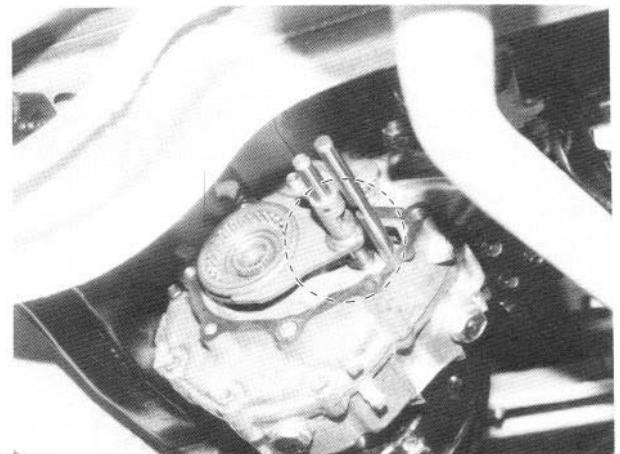
**Fig. 14-39 Output high gear**



**Fig. 14-40 Output low gear**

**Gear Shift Shafts**

Check each part as indicated in below figures for uneven wear. Replace defective parts.



**Fig. 14-41**

#### 4WD Gear Shift Lever

Check lower end of gear shift lever where gear shift fork shaft contacts ① for wear and any kind of damage. Worn or damaged shift lever must be replaced with new one.



Fig. 14-42

## 14-8. REASSEMBLY

### NOTE:

- 1 All parts to be used in reassembly must be perfectly clean.
- 1 Oil or grease sliding and rubbing surfaces of transfer components just before using them in reassembly with gear oil and SUZUKI SUPER GREASE A (99000-25010).
- 1 Oil seals, "O" rings, gaskets and similar sealing members must be in perfect condition. For these members, use replacement parts in stock.
- 1 Tightening torque is specified for important fasteners — mainly bolts — of transfer and other components. Use torque wrenches and constantly refer to specified data given in P. 14-23.

### Input Shaft

Press-fit bearings onto both sides of input shaft by using bearing installer (special tool).

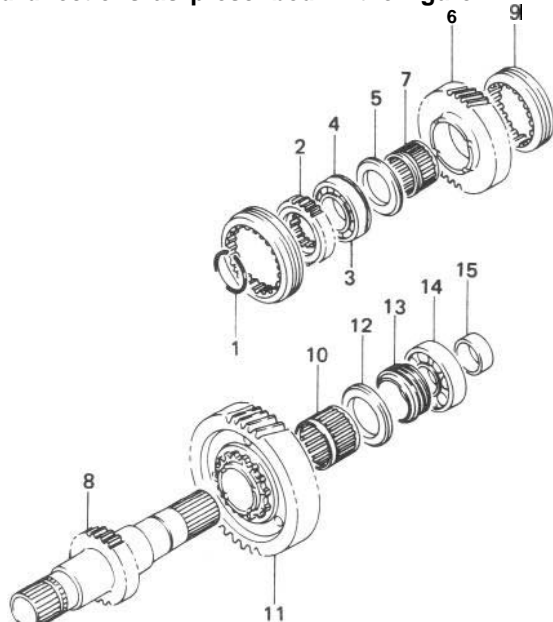
Bearing installer (A) : (09913-84510)



Fig. 14-43

## Output Rear Shaft

Install following parts onto shaft in such order and directions as prescribed in the figure.



- |                       |                            |
|-----------------------|----------------------------|
| 1. Circlip            | 9. Sleeve                  |
| 2. Hub                | 10. Bearing (short)        |
| 3. Bearing            | 11. Output low gear        |
| 4. Bearing outer ring | 12. Thrust washer          |
| 5. Thrust washer      | 13. Speed meter drive gear |
| 6. Output high gear   | 14. Bearing                |
| 7. Bearing (long)     | 15. Retainer               |
| 8. Output rear shaft  |                            |

Fig. 14-44

- 1) After installing bearing (long), high gear and thrust washer, press-fit bearing 1. and then hub ② by using bearing installer (special tool).

Bearing installer (A) : (0991384510)

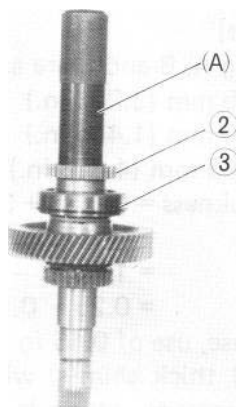


Fig. 14-45

- 2) Fit circlip ① securely into groove in shaft.

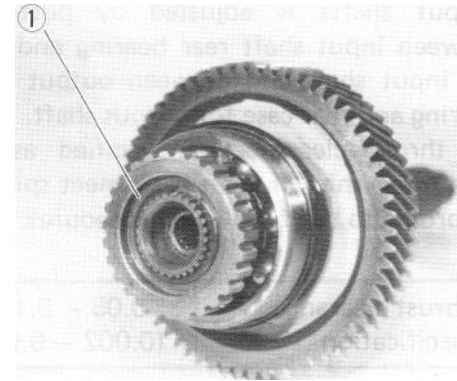


Fig. 14-46

- 3) After installing sleeve, bearing (short), low gear and thrust washer, press-fit speedometer drive gear by using bearing installer (special tool).

Bearing installer (A) : (09913-84510)

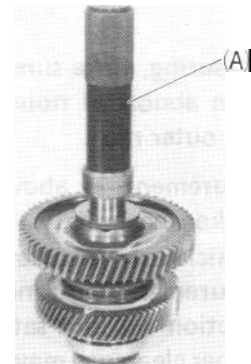


Fig. 14-47

- 4) Press-fit bearing ⑭ and the retainer ⑮ by using bearing installer (special tool).

Bearing installer (A) : (0991384510)

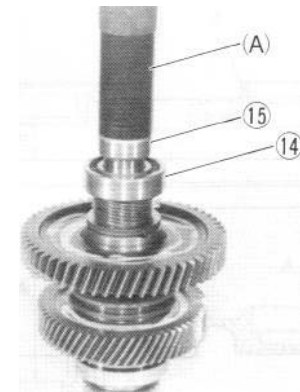


Fig. 14-48

**Shim Adjustment of Input and Output Shafts**  
 Clearance in thrust direction of both input and output shafts is adjusted by putting shims between input shaft rear bearing and rear case for input shaft and between output shaft rear bearing and rear case for output shaft.  
 As thrust clearance is specified as follows determine shim thickness to meet specification according to the following procedures.

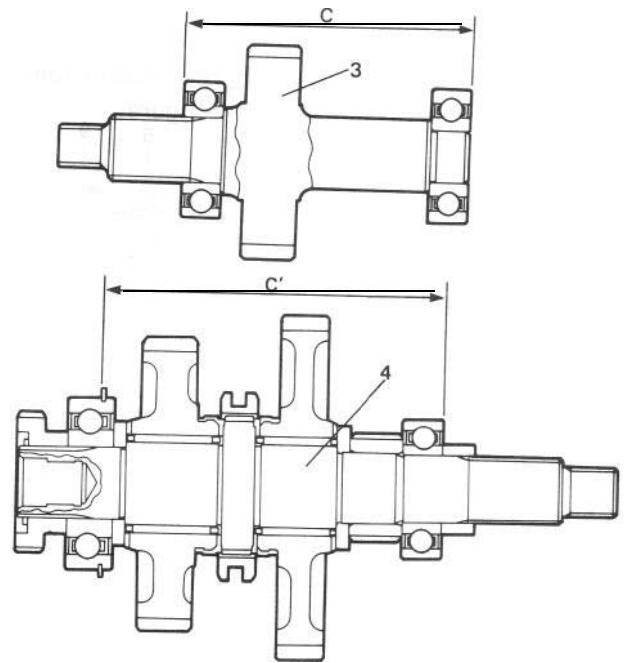
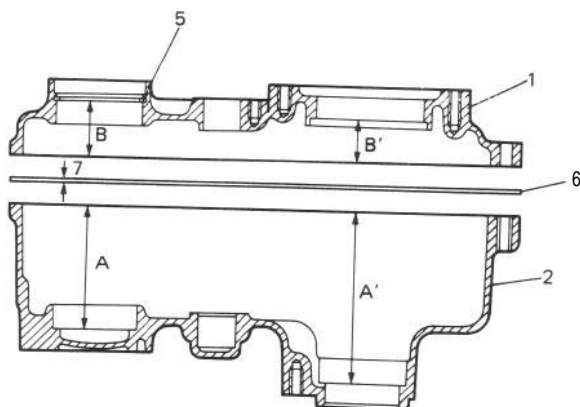
Thrust clearance specification	0.05 – 0.15 mm (0.002 – 0.006 in.)
--------------------------------	---------------------------------------

**[Input shaft]**

- 1) Take measurement “A” of rear case as shown in figure below by using depth gauge,
- 2) Take measurement “B” of center case with bearing circlip installed.
- 3) Take measurement “C” (between bearing inner races) of input shaft with bearings installed, by using micrometer.

**NOTE:**

- 1 Before measuring, make sure that each bearing is free from abnormal noise or resistance by spinning its outer race.
- 1 Each measurement in above steps 1) to 3) must be taken accurately in careful manner, If shim thickness is determined based on rough measurement, clearance of each shaft in thrust direction will not satisfy specification. And improper clearance may cause oil leakage, broken bearing and abnormal noise.
- 1 Take the same measurement at 3 to 4 different positions and use their mean.



- |                 |   |
|-----------------|---|
| 1. Center case  | 5. Bearing circlip                          |
| 2. Rear case    | 6. Gasket                                   |
| 3. Input shaft  | 7. Gasket thickness<br>(0.3 mm or 0.012 in) |
| 4. Output shaft |   |

**Fig. 14-48-1**

- 4) Using measurements obtained in steps 1) to 3) and equation described below, calculate shim thickness which is necessary for proper thrust clearance.

$$\text{Thrust clearance} = (\text{“A”} + \text{“B”} + \text{Gasket thickness}) - \text{“C”}$$

As the above equation holds for thrust clearance and gasket thickness is specified as 0.3 mm and thrust clearance as 0.05 to 0.15 mm, shim thickness is calculated by the following equation.

$$\text{Shim thickness} = (\text{“A”} + \text{“B”} + 0.3) - (\text{“C”} + 0.05 \sim 0.15)$$

**[Example]**

Supposing A, B and C are as follows;

$$A = 81.35 \text{ mm (3.203 in.)}$$

$$B = 35.70 \text{ mm (1.405 in.)}$$

$$C = 117.05 \text{ mm (4.608 in.)}$$

$$\begin{aligned} \text{Shim thickness} &= (81.35 + 35.70 + 0.3) - \\ &\quad (117.05 + 0.05 \sim 0.15) \\ &= 117.35 - 117.10 \sim 117.20 \\ &= 0.25 \sim 0.15 \end{aligned}$$

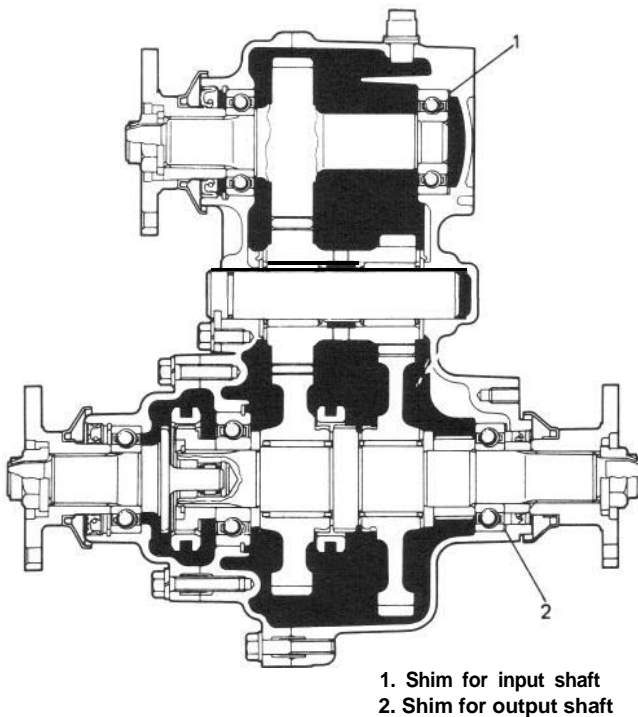
In this case, use of 0.15 to 0.25 mm (0.006 to 0.009 in) thick shim(s) will ensure specified thrust clearance which is 0.05 to 0.15 mm (0.002 to 0.006 in). Therefore 2 pieces of 0.1 mm (0.004 in) thick shim should be selected in available shims below to satisfy thickness.

5) When shim thickness is determined, select proper shim(s) from among the following shims and use it (them) between input shaft rear bearing and rear case when matching center case and rear case.

Available shim size (thickness)	0.1, 0.3, 0.5 mm (0.004, 0.012, 0.020 in.)
---------------------------------	---

[Output shaft]

Just as with input shaft, take measurements of "A'", "B'" and "C'" as indicated in Fig. 14-48-1, calculate shim thickness and install proper shim(s) between output shaft rear bearing and rear case when matching center case and rear case.



**Fig. 14-48-2**



### Rear Case

- 1) Install oil seal in rear case and apply grease to oil seal lip.

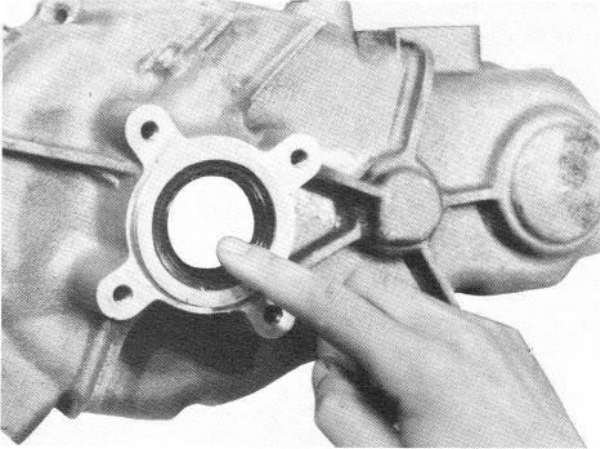


Fig. 14-49

- 2) Install counter shaft thrust washer to rear case, bringing its face without depressions against case and fit its bent portion securely into groove in case.

### NOTE:

Apply ample amount of grease to both surfaces of washer so as to lubricate sliding surfaces and prevent washer from moving out of place or slipping off.

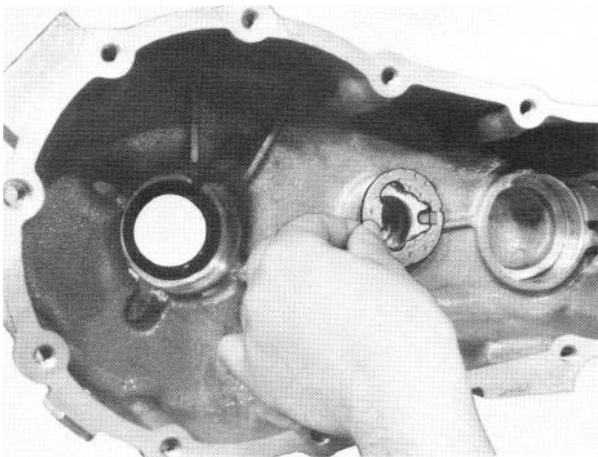


Fig. 14-50

### Center Case

- 1) Install input shaft front bearing circlip and oil seal in center case.  
Snap ring pliers (A) : (09900~6108)

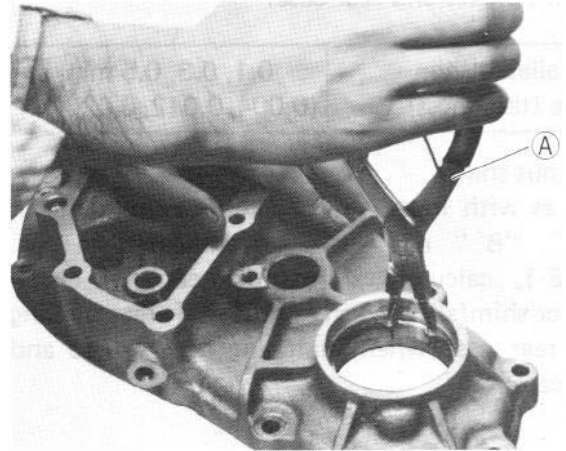


Fig. 14-51

- 2) Install input shaft to center case.

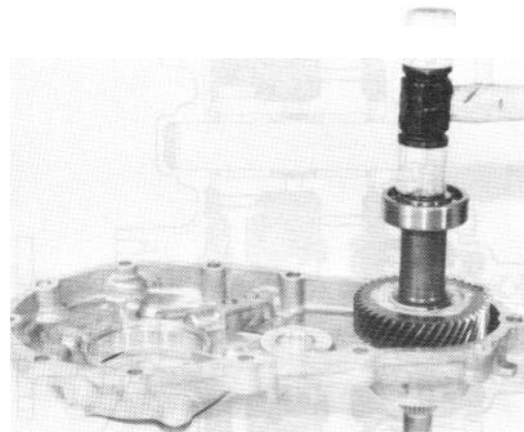


Fig. 14-52

- 3) After greasing O ring on counter shaft, insert shaft into center case and secure shaft with lock plate and bolt.

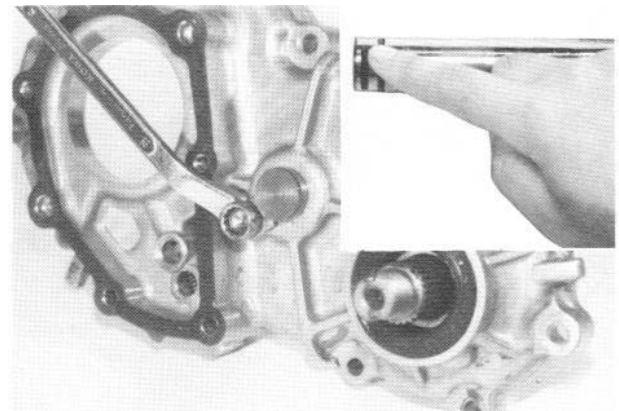


Fig. 14-53



4) Install the counter shaft thrust washer to center case. For installation, apply ample amount of grease to both faces of the washer so as to lubricate sliding surfaces and prevent it from moving out of place or slipping off and bring its face without depressions against center case, and fit its bent portion into groove in case securely.

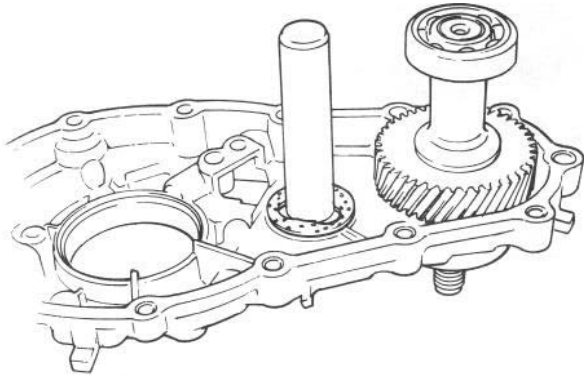


Fig. 14-54

5) Install needle roller bearings, spacer and counter gear on counter shaft.

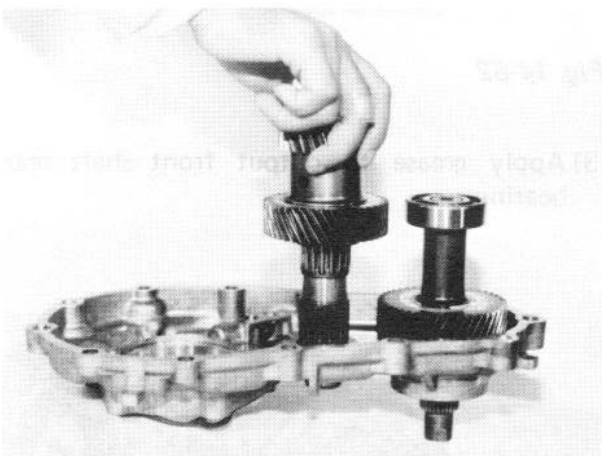


Fig. 14-55

6) Install output shaft assembly to center case.



Fig. 14-56

7) When installing front drive shift shaft and reduction shift shaft in center case, install spring ①, ball ②, shaft ③, ball ④, shaft ⑤, ball ⑥, spring ⑦ and plug 8. in that order.

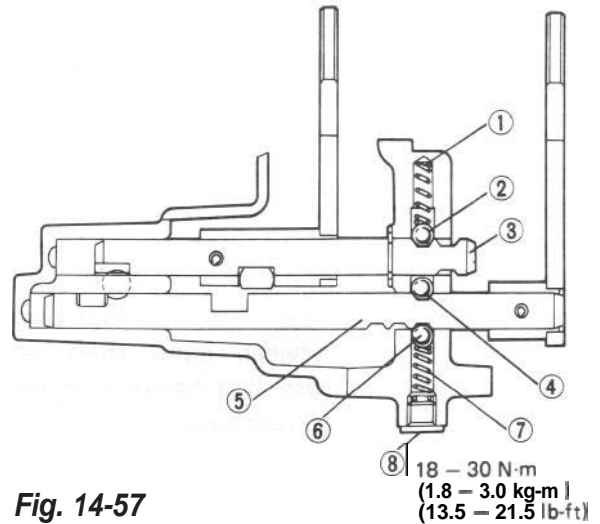


Fig. 14-57

8) Fit forks on shift shafts and lock them with spring pins. Forks should be fitted in correct direction according to below figure.

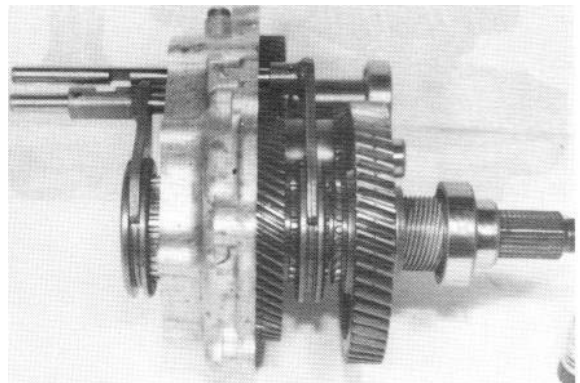
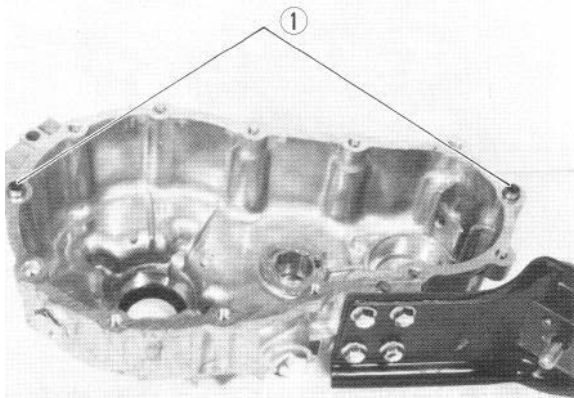


Fig. 14-58

## Center and Rear Cases

- 1) Check center case (or rear case) to ensure that it is provided with 2 dowel pins ①

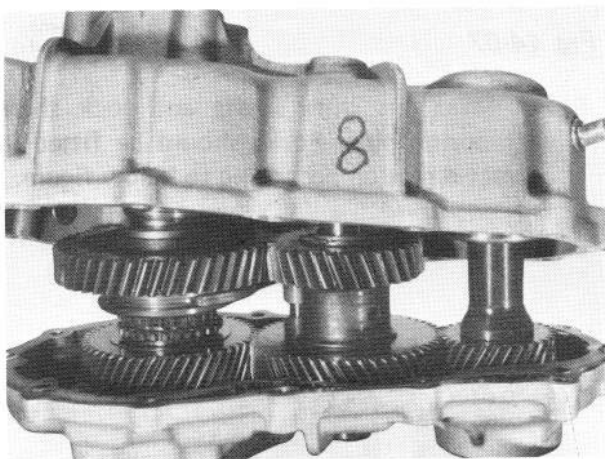


**Fig. 14-59**

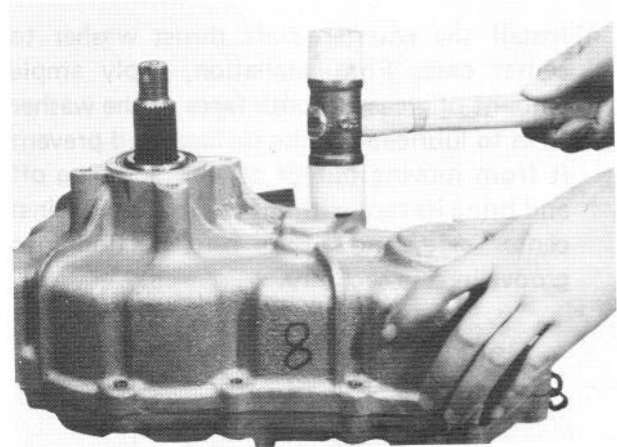
- 2) Put gasket on center case. Bring rear case and center case into match and apply uniform force gradually all around rear case with a plastic hammer. Tighten center case securing bolts to specified torque.

### NOTE:

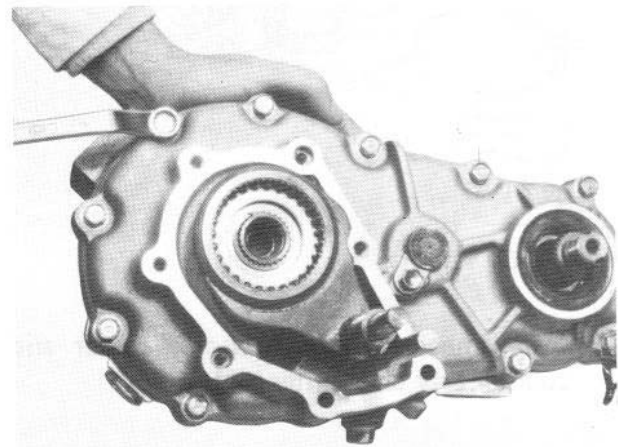
- 1 Matching must be made carefully so as not to move countershaft thrust washers out of place.
- 1 Be sure to install shims determined in previous item "Shim Adjustment of Input and Output Shafts" between input shaft rear bearing and rear case and between output shaft rear bearing and rear case.



**Fig. 14-60**

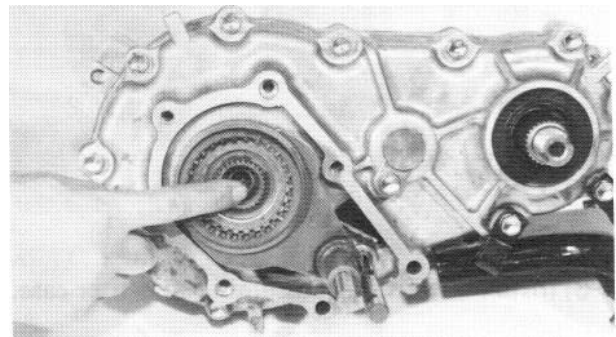


**Fig. 14-61**



**Fig. 14-62**

- 3) Apply grease to output front shaft rear bearing.



**Fig. 14-63**

## Front Case

- 1) Install bearing, circlip and oil seal to front case. Apply grease to oil seal lip and install output front shaft using bearing installer (special tool).

Bearing installer (A) : (09913-76010)

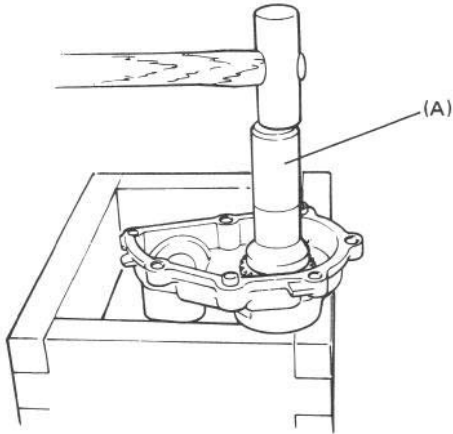


Fig. 14-64

- 2) Put gasket on center case.
- 3) Check front case to ensure that it is provided with 2 dowel pins.

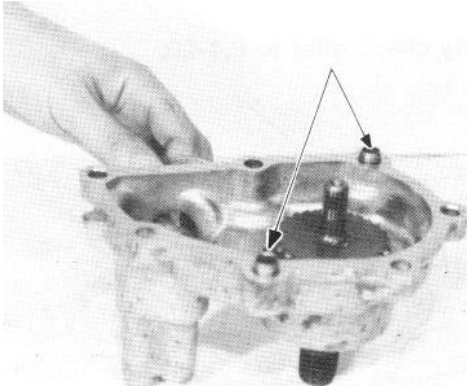


Fig. 14-65

- 4) Install front case to center case.

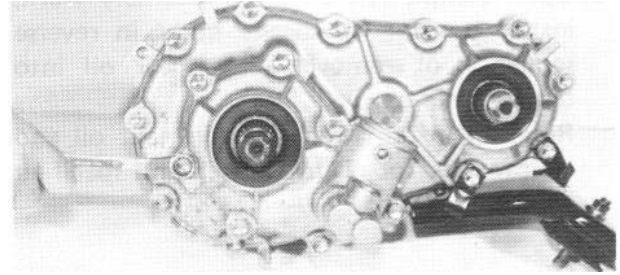


Fig. 14-66

- 5) When installing speedometer driven gear and its gear case in rear case, apply grease to O ring and oil seal lip, and align bolt holes in rear case and driven gear case.

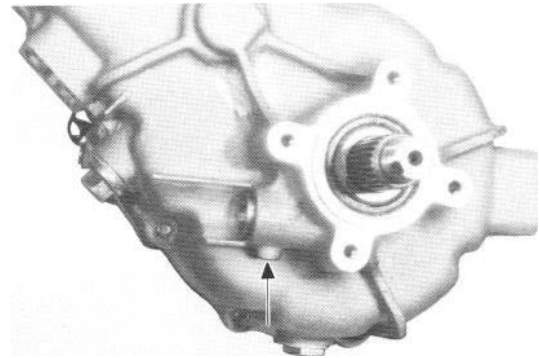


Fig. 14-67

- 6) Install 4WD ball and switch. Then clamp switch lead wire properly.

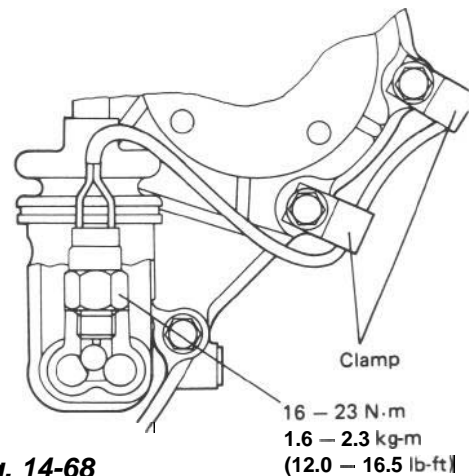


Fig. 14-68



- 7) Install propeller shaft flanges and tighten nuts to specified torque and **calk** the nuts.
- 8) Upon completion of entire assembly work, install transfer in chassis body in reverse sequence of removal. Pour gear oil into transfer gear box.  
Refer to information given in next oil and oil capacity for oil to be used and specified amount.

**NOTE:**

**When installing oil filler and drain plugs to transfer case, apply sealant (SUZUKI BOND No.1215, 99000-31110) to thread part of plug.**

## 14-9. MAINTENANCE SERVICES

### Oil Level

Oil level must be checked with car held in horizontal position in both front to rear and side to side directions.

Oil level plug and oil filler plug are one and the same as shown in figure.

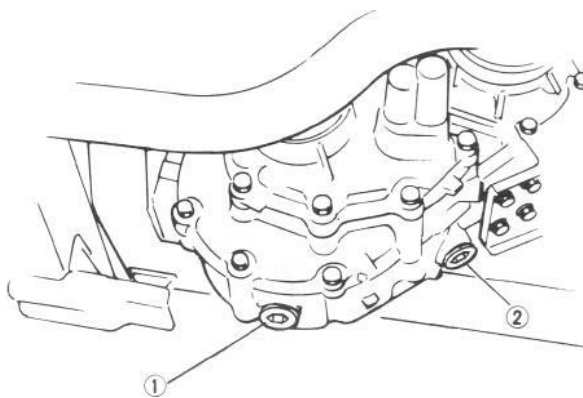
If oil flows out of filler plug hole or if oil level is found up to hole when plug is removed, amount of oil is appropriate. Replenish oil if noted as insufficient.

### Oil and Oil Capacity

Whenever car is lifted up for any service including oil change, make sure to check around transfer gear box for oil leakage. Correct defects, if any, and change or refill oil.

Transfer oil capacity	0.8 litre (1.7/1.4 US/Imp. pt)
Transfer oil specification	Gear oil SAE 80W-90, 75W-80 or 75W-90

It is highly recommended to use SAE 75W-90 gear oil.  
For viscosity chart, refer to P. 1-20.



- ① : Oil drain plug
- ② : Oil filler & level plug

**Fig. 14-70**

## 14-10. TIGHTENING TORQUE

Fastening parts	N·m	lb-ft
	kg-m	
Front case bolt	13 – 23	9.5 – 16.5
	1.3 – 2.3	
Center case bolt	13 – 23	9.5 – 16.5
	1.3 – 2.3	
Counter shaft lock plate bolt	9 – 17	7.0 – 12.0
	0.9 – 1.7	
Universal joint flange nut	110 – 150	80.0 – 108.0
	11.0 – 15.0	
Transfer mounting bracket bolt	18 – 28	13.5 – 20.0
	1.8 – 2.8	
Transfer mounting nut	25 – 35	18.5 – 25.0
	2.5 – 3.5	
Cross joint bolt & nut	23 – 30	17.0 – 21.5
	2.3 – 3.0	
Oil filler and drain plug	18 – 28	13.5 – 20.0
	1.8 – 2.8	

**SECTION 15**

**PROPELLER SHAFTS**

**CONTENTS**

**15-1. GENERAL DESCRIPTION ..... 15-2**

**15-2. REMOVAL ..... 15-3**

**15-3. INSTALLATION ..... 15-3**

**15-4. MAINTENANCE SERVICES. .... 15-4**

**15-5. TIGHTENING TORQUE ..... 15-5**

**15-6. DISASSEMBLY ..... 15-6**

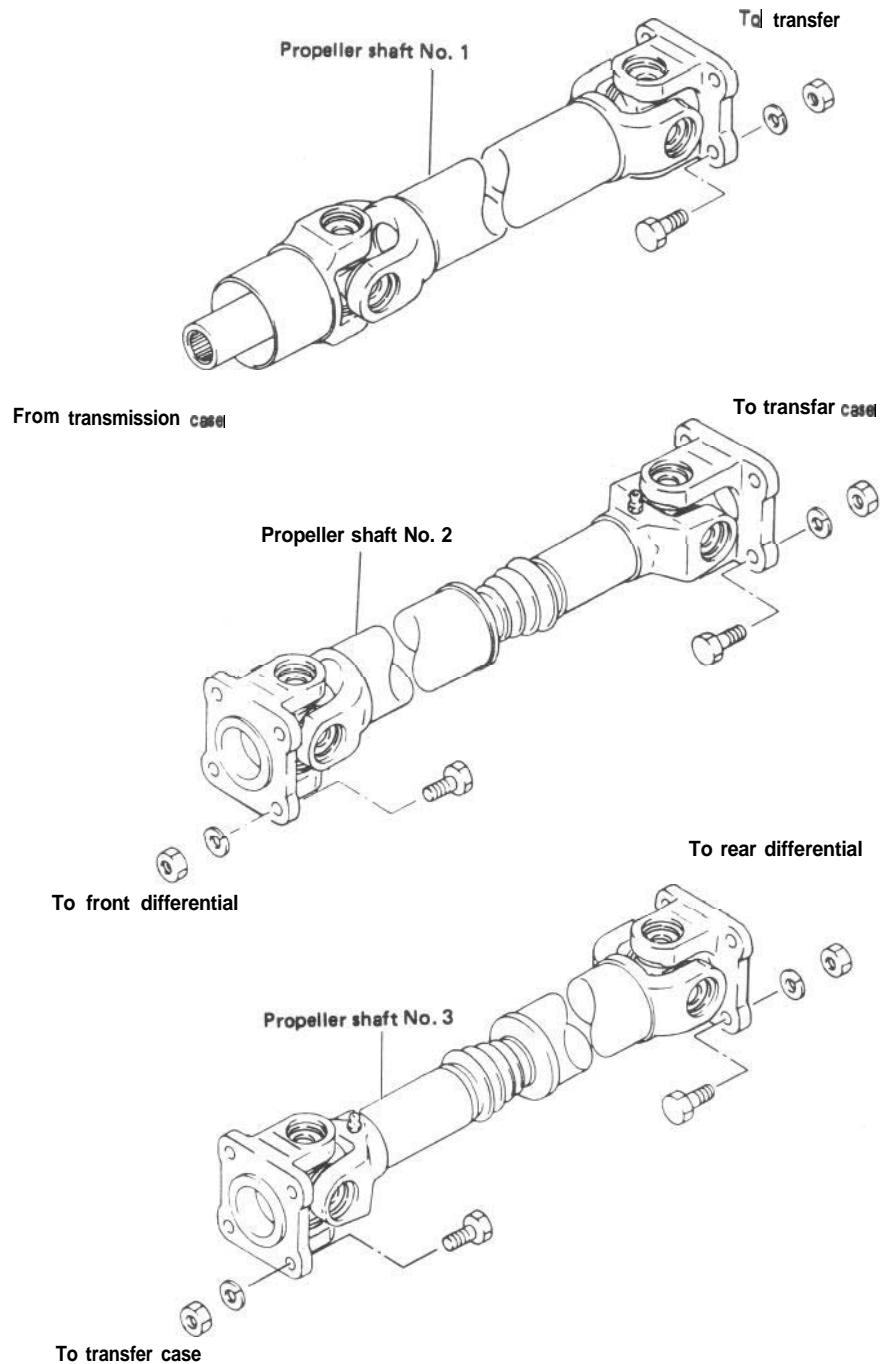
**15-7. REASSEMBLY ..... 15-7**

## 151. GENERAL DESCRIPTION

These automobiles, covered in this manual are four-wheel drive machines and, as such, use three propeller shafts designated as No. 1, No. 2 and No. 3.

No. 1 propeller shaft transmits drive from the transmission to the transfer gear box. No. 2 shaft and No. 3 shaft extend from the transfer gear box, the former driving the front axle and the latter the rear axle.

The cross spider in each universal joint is fitted with four needle roller bearings.



**Fig. 15-1**

## 15-2. REMOVAL

- 1) Hoist car.
- 2) Loosen propeller shaft nuts and bolts.
- 3) Remove propeller shaft.

Transmission-side end of No. 1 shaft has no flange piece; this end is splined to driving shaft inside extension case. All you have to do there is to pull No. 1 shaft off extension case.

### NOTE:

When withdrawing propeller shaft No. 1 from transmission, transmission oil will not leak, provided oil level is to specification and car is raised horizontally in its front and rear direction. However, if only car front is hoisted, be sure to drain transmission oil before withdrawing propeller shaft No. 1.

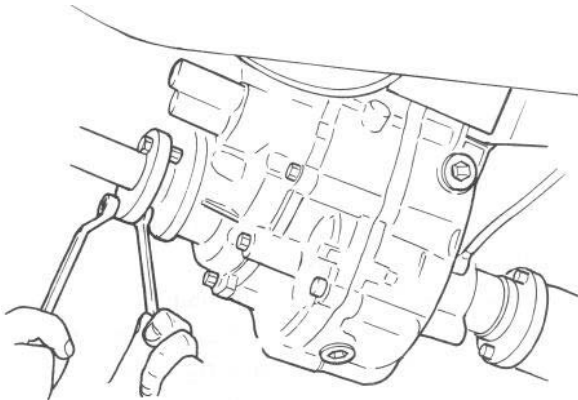


Fig. 15-2

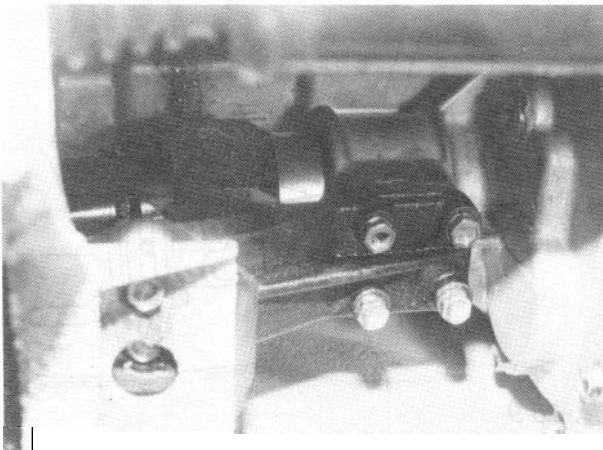


Fig. 15-3

## 15-3. INSTALLATION

The installing procedure is reverse of the removal procedure. Be sure to adhere to following instructions when installing shafts:

- 1 Flange tightening torque

Be sure to tighten 4 nuts to the following torque when securing companion flange to yoke at each end of propeller shaft:

Tightening torque for universal joint flange bolts & nuts	23-30 N·m (2.3-3.0 kg-m) (17.0 - 21.5 lb-ft)
---	--

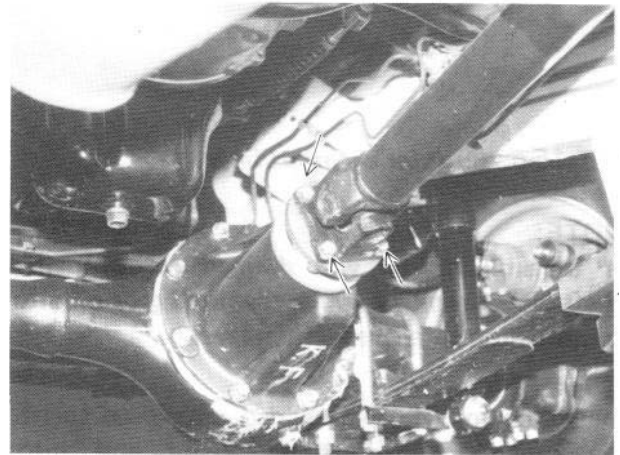


Fig. 15-4

- 1 Grease splines liberally, filling grooves with grease.

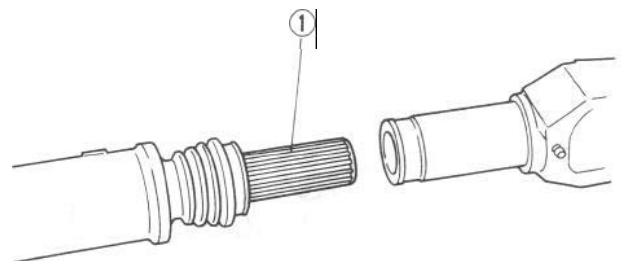
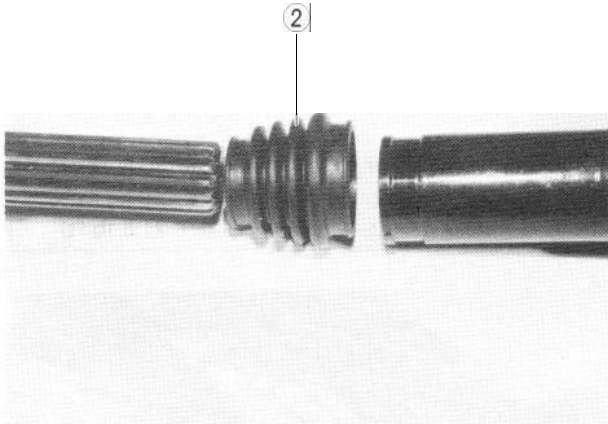


Fig. 15-5 ① Grease (chassis grease)



- 1 Joint sheath rubber has a large diameter in one end and a small diameter in the other. Be sure to fit sheath rubber with its large diameter end brought to joint yoke side.

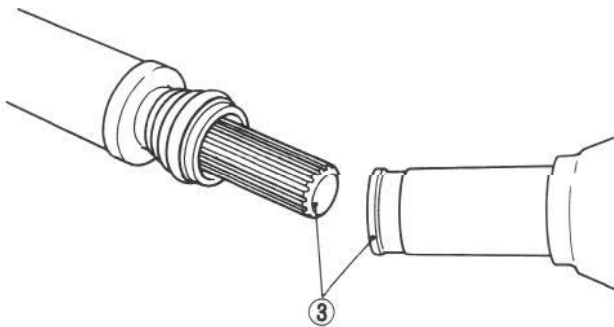


**Fig. 15-6** ② *Joint sheath rubber*

**NOTE:**

If transmission oil was drained for propeller shaft No. 1 removal, pour specified gear oil into transmission case to specified level.

- 1 Match marks are provided on slip-on spline connections. Inserting splined end into splined bore without regard to match marks can be a possible cause of noise or vibration of propeller shaft. Be sure to index marks.

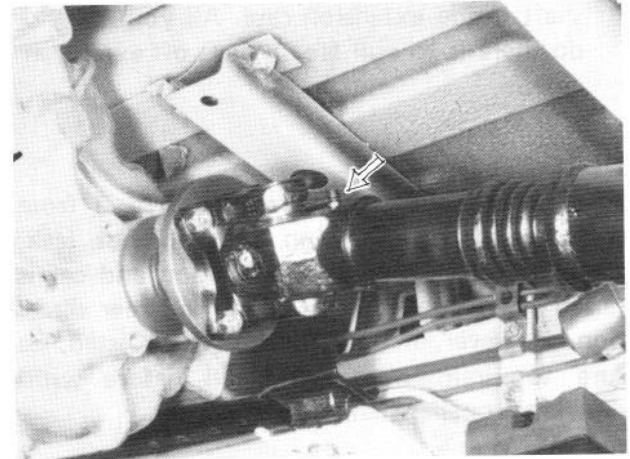


**Fig. 15-7** ③ *Match marks*

## 15-4. MAINTENANCE SERVICES

### Lubrication

Inside yoke of each universal joint has a grease nipple. At regular intervals stated in the recommended servicing schedule, pump in grease to relubricate joint. Use chassis grease.

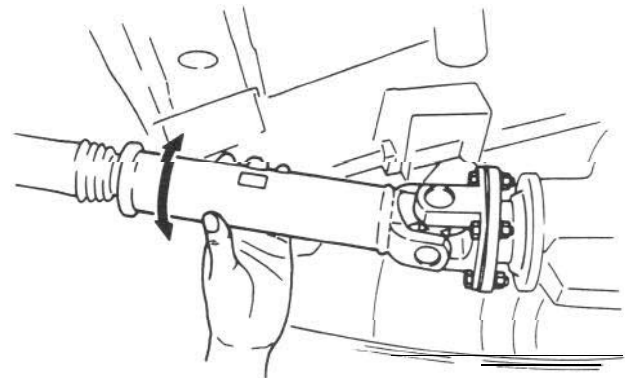


**Fig. 15-8**

### Universal Joint Noise

If universal joints are suspected of producing chattering or rattling noise, inspect them for wear. Check to see if cross spider rattles in yokes or if splines are worn down and replace defective propeller shaft with new one.

The noise coming from universal joint can be easily distinguished from other noises because rhythm of chattering or rattling is in step with cruising speed. Noise is pronounced particularly on standing start or in coasting condition (when braking effect of engine is showing in the drive line).



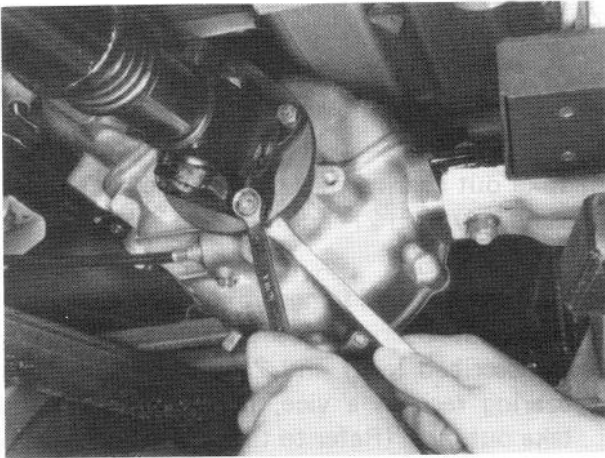
**Fig. 15-9**

## 15-5. TIGHTENING TORQUE

### Bolts & Nuts

Check following bolts and nuts for tightness and retighten them as necessary:

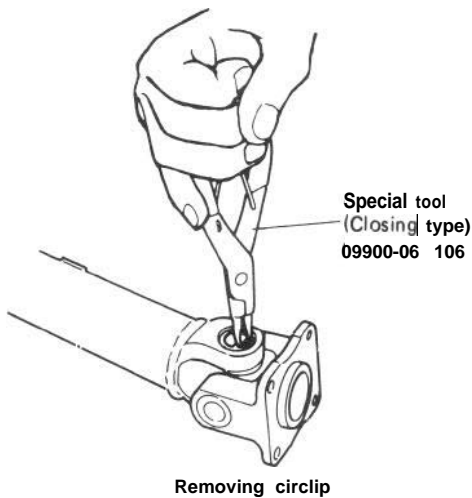
Fastening parts	N·m	kg-m (lb-ft)
Propeller shaft bolt & nut	23 – 30	2.3 – 3.0 (17.0 – 21.5)



*Fig. 15-10*

## 15-6. DISASSEMBLY

- 1 Disassembling on propeller shaft yoke side.
- 1) Using snap ring pliers (Special tool), remove 2 circlips.



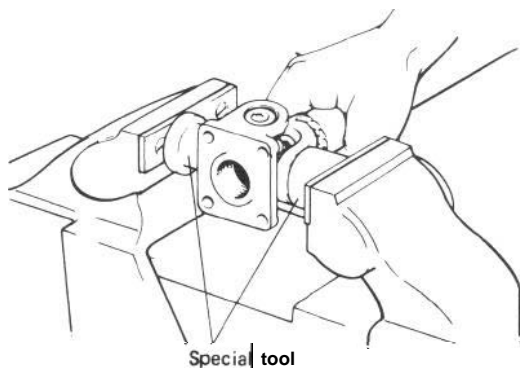
**Fig. 15-11**

Removing circlip

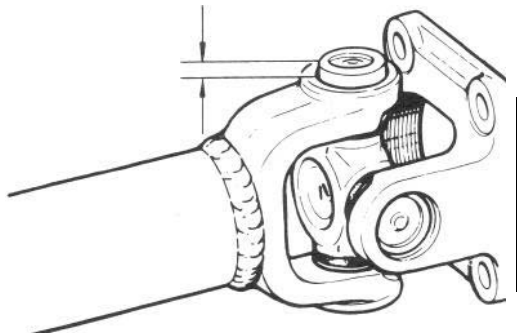
- 2) Using universal joint assembler (Special tool 09926-48010), push spider bearing race out 3 – 4 mm (0.12 – 0.16 in.) from shaft yoke race.

**NOTE:**

Before pushing it out, apply penetrate lubricant between bearing race and yoke race.

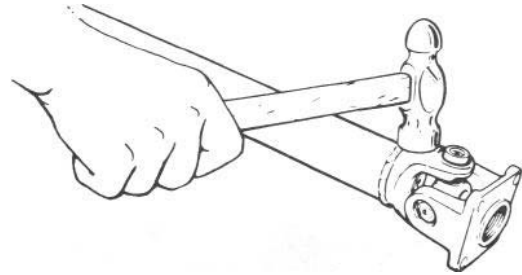


3 – 4 mm (0.12 – 0.16 in.)



**Fig. 15-12**

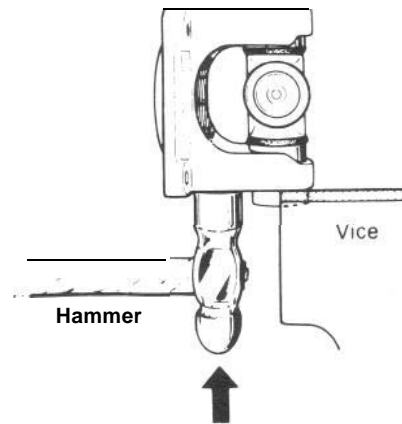
- 3) Tapping yoke with a hammer, completely remove bearing race.



**Fig. 15-13**

- 4) Take out bearing race on the other side in the same way as in 2) and 3).

- 1 Disassembling on flange yoke side
- Push out bearing race on flange yoke side as described in 1) and 2), and then, holding bearing race in a vice, tap flange yoke and take out race, (Refer to the below figure.)
- Remove bearing race on the opposite side in the same way.



**Fig. 15-14**

**NOTE:**

- 1 Take care not to lose rollers in spider bearing race when removing it.
- 1 Fit removed bearings temporarily in spider so that they can be reinstalled in their original positions.

## 15-7. REASSEMBLY

### NOTE:

- 1 Make certain that rollers inside spider bearing race are all in place.
- 1 Make sure to apply SUPER GREASE C (99000-25030) to spider bearing race.

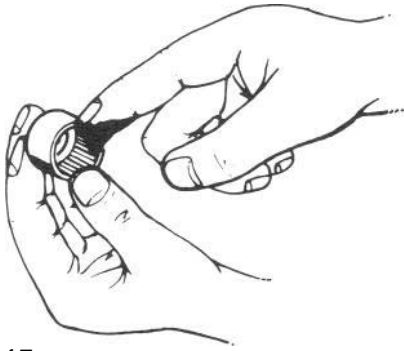


Fig. 15-15

### CAUTION:

In reassembly, be sure to use new circlips, spider and bearings. Reuse of circlips, spider and bearings once reassembled is prohibited

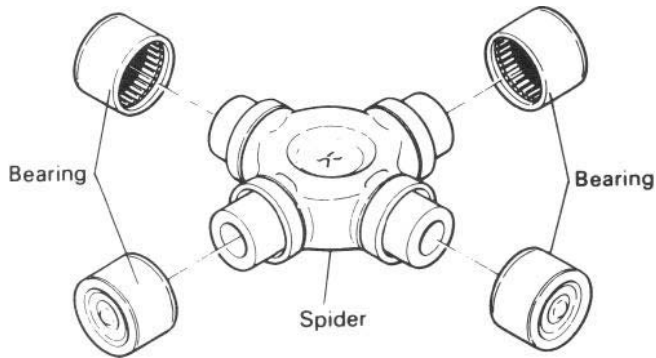
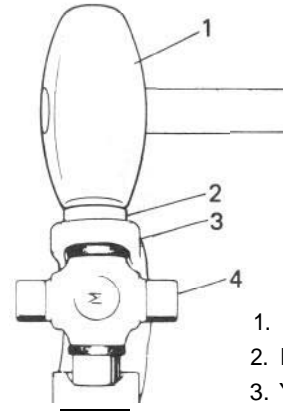


Fig. 15-16

- 1) Insert bearing race into yoke, tapping it with a hammer, until it is flush with yoke face. When doing this, insert spider into bearing race to prevent rollers in bearing race from coming out.



1. Copper hammer
2. Bearing race
3. Yoke
4. Spider

Fig. 15-17

- 2) Insert the other bearing race on the opposite side into yoke, tapping with a hammer until it is flush with yoke face.
- 3) Insert bearing races on the flange yoke side in the same way as described in 1) and 2) above.

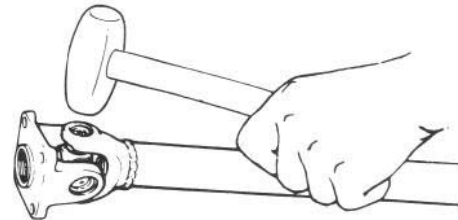


Fig. 15-18

- 4) Place a metal plate on bearing races when tapping them in to avoid damaging yoke.
- 5) Securely fit 4 circlips to shaft and flange yoke.

### NOTE:

- 1 After reassembly, check to ensure that both shaft yoke and flange yoke move smoothly.
- 1 Make sure that each circlip is fitted in the groove securely.

6) inspect propeller shaft and flange yoke for damage, and propeller shaft for runout  
If damage is found or shaft runout exceeds specifications, replace.

Runout limit	0.8 mm (0.031 in.)
--------------	-----------------------

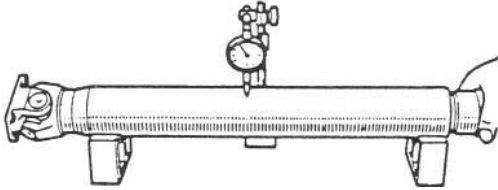


Fig. 15-19

**SECTION 16**  
**DIFFERENTIAL**

**CONTENTS**

<b>16-1. GENERAL DESCRIPTION .....</b>	<b>16-2</b>
<b>16.2. REMOVAL .....</b>	<b>16-3</b>
<b>16-3. DISASSEMBLY .....</b>	<b>16-6</b>
<b>16-4. INSPECTION AND ADJUSTMENT OF COMPONENTS .....</b>	<b>16-7</b>
<b>16.5. REASSEMBLY .....</b>	<b>16-13</b>
<b>16-6. INSTALLATION .....</b>	<b>16-15</b>
<b>16-7. MAINTENANCE SERVICES .....</b>	<b>16-16</b>
<b>16-8. RECOMMENDED TORQUE SPECIFICATIONS .....</b>	<b>16-16</b>

## 16-1. GENERAL DESCRIPTION

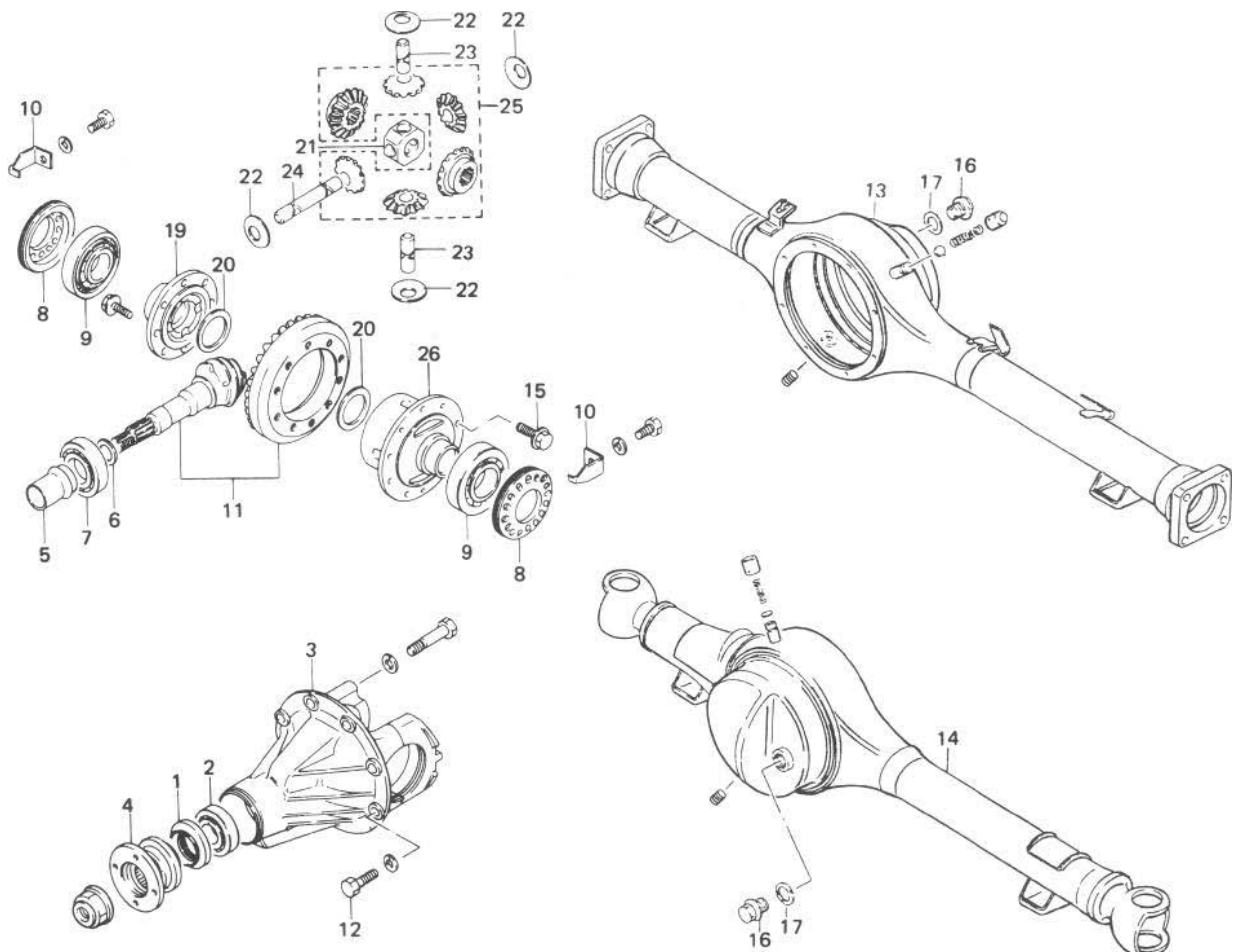
The two axles, front and rear, are identical as far as the designs of pinion-and-gear drive and differential gearing are concerned. The major difference in this limited sense lies in the shape of the housing.

Each axle may be regarded as consisting, speaking roughly, of supporting parts (axle sleeves, differential housing and carrier case) and drive transmitting parts (bevel pinion and gear, differential gearing and live axle shafts). In the present section, only the bevel pinion and gear and differential gearing are taken up under the collective title of "differential."

The bevel gear drive is of hypoid design; pinion and gear have hypoid gear teeth. This means that the pinion is located slightly below the center of the bevel gear to permit the car body to be lowered in design, and that some wiping or sliding action occurs in tooth meshing between pinion and gear. Here lies the reason why use of hypoid gear oil is specified for the differential.

Four differential pinions are used in the differential case to qualify this gearing for heavy-duty "differential" drive. Thus, a total of 8 gears—a drive pinion, a crown gear, two side gears and four pinions—are inside the differential housing, all mounted on the differential carrier case bolted to the housing.

This differential is so constructed that the bevel pinion bearing preload is adjusted by tightening the bevel pinion nut to compress the spacer.



- |                                     |                           |                        |
|-------------------------------------|---------------------------|------------------------|
| 1. Oil seal                         | 9. Side bearing           | 18. Oil drain plug     |
| 2. Bearing                          | 10. Adjuster lock plate   | 19. Right case         |
| 3. Carrier                          | 11. Bevel gear pinion set | 20. Thrust washer      |
| 4. Joint flange                     | 12. Bolt                  | 21. Joint              |
| 5. Bearing preload adjusting spacer | 13. Rear axle housing     | 22. Thrust washer      |
| 6. Shim                             | 14. Front axle housing    | 23. Pinion shaft No. 2 |
| 7. Bearing                          | 15. Bolt                  | 24. Pinion shaft No. 1 |
| 8. Bearing adjuster                 | 16. Oil level plug        | 25. Side gear set      |
|                                     | 17. Gasket                | 26. Left case          |

Fig. 16-1

## 16-2. REMOVAL

1. Loosen, but do not remove, wheel nuts of front or rear wheels, and raise car off the floor by jacking.  
Rest car steady on safety stands.
2. Drain out oil in differential housing by loosening drain plug.
3. Remove wheel nuts and take off wheels, front or rear. Each wheel has five wheel nuts.

### For Front Differential

After taking down front wheels, remove disc brake caliper with carrier.

### NOTE:

Hang removed caliper with a wire hook or the like so as to prevent brake hose from bending and twisting excessively or being pulled.

Don't operate brake pedal with caliper removed.

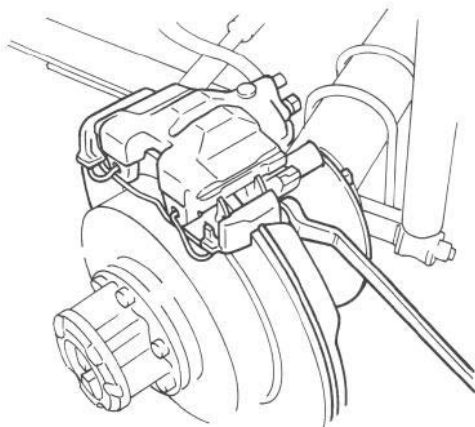


Fig. 16-2

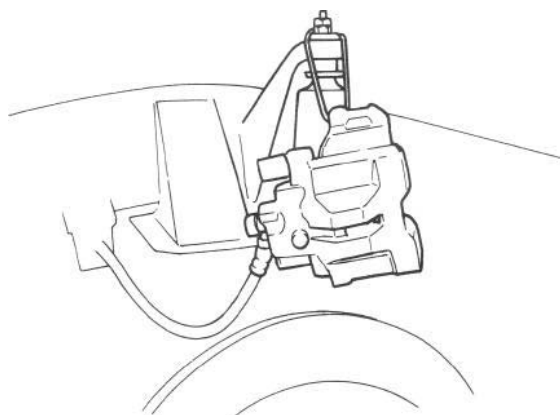


Fig. 16-3

At each tie rod end, remove nut and disconnect the end from steering knuckle using special tool

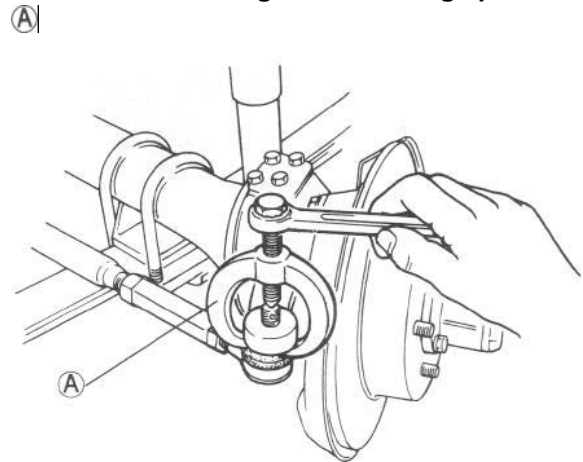


Fig. 16-4 (A) Special tool (Tie rod endremover 099 13-652 10)

Remove 8 oil seal cover securing bolts. From steering knuckle, take off felt pad, oil seal and seal retainer.

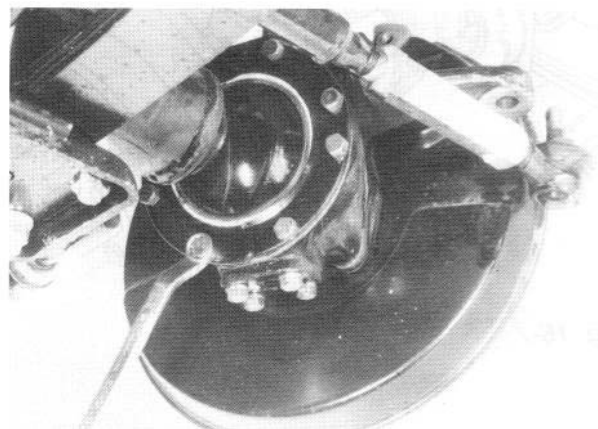


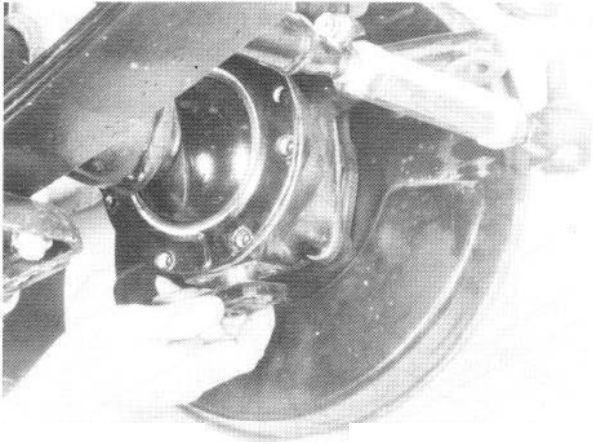
Fig. 16-5

Remove top and bottom kingpins from knuckle by removing 4 bolts securing each pin.

### NOTE:

The removed top and bottom kingpins must be kept separated so as to prevent an error when putting them back in their place in reassembly.



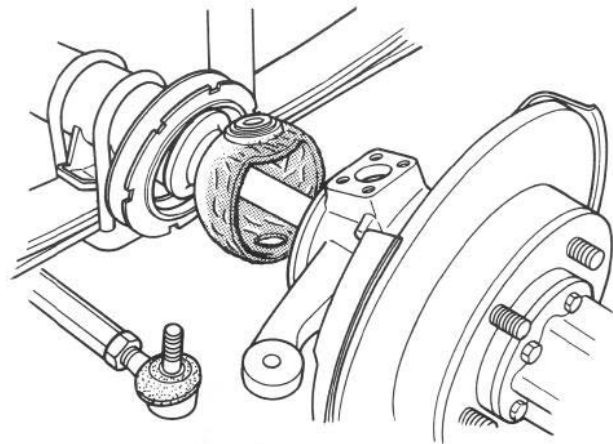


**Fig. 16-6**

Draw out live axle shaft from axle housing.

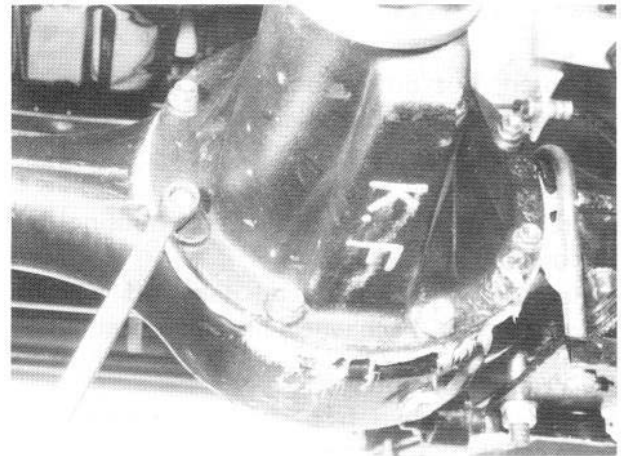
**NOTE:**

At this time, lower kingpin bearing sometimes falls off. So remove bearing while pulling off knuckle gradually.



**Fig. 16-7**

At differential housing, disconnect propeller shaft by removing bolts securing flange yoke to companion flange. Remove 8 bolts holding fast differential carrier case to housing, and take down carrier assembly.



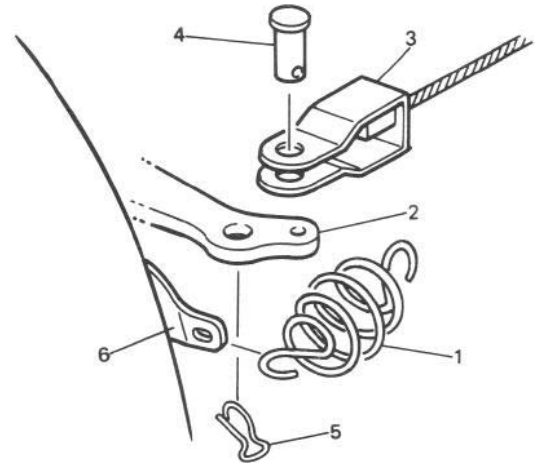
**Fig. 16-8**

**For Rear Differential**

After taking down rear wheels, remove brake drums by using special tools.

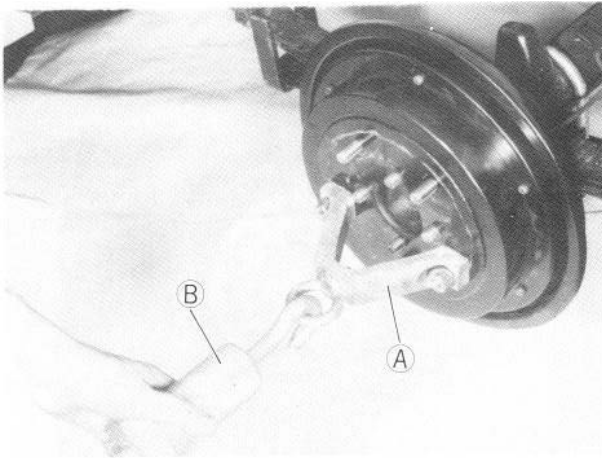
**NOTE:**

Before removing brake drum, check to ensure that parking brake lever is not pulled up. To increase clearance between brake shoe and brake drum, remove parking brake shoe lever return spring ① and disconnect parking brake cable joint ③ from parking brake shoe lever ②. Remove parking brake shoe lever stopper plate.



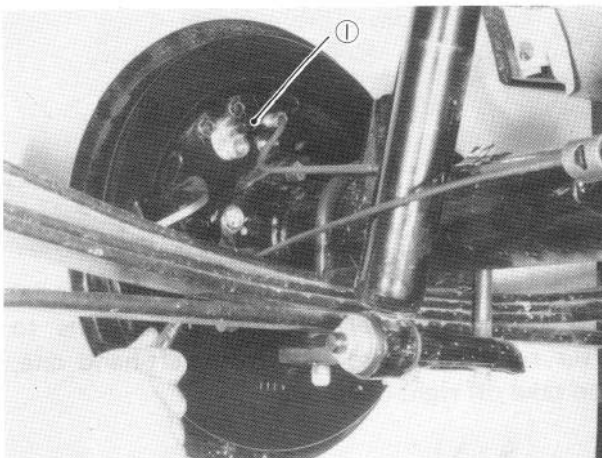
- |   |                     |
|---|---------------------|
| 1. Parking brake shoe lever return spring | 4. Pin              |
| 2. Parking brake shoe lever               | 5. Clip             |
| 3. Parking brake cable joint              | 6. Brake back plate |

**Fig. 16-9**



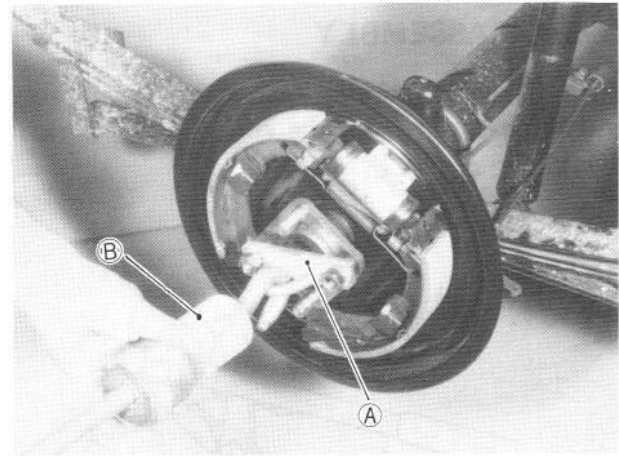
**Fig. 16-19-1** (A) *Special tool (Brake drum remover 09943-355 71)*  
 (B) *Special tool (Sliding hammer 09942 15510)*

Disconnect brake pipe from wheel cylinder. Have a small plug ready for use when disconnecting pipe. As pipe comes off the wheel cylinder, plug the pipe to prevent brake fluid from leaking out. And remove 4 brake backing plate securing bolts.



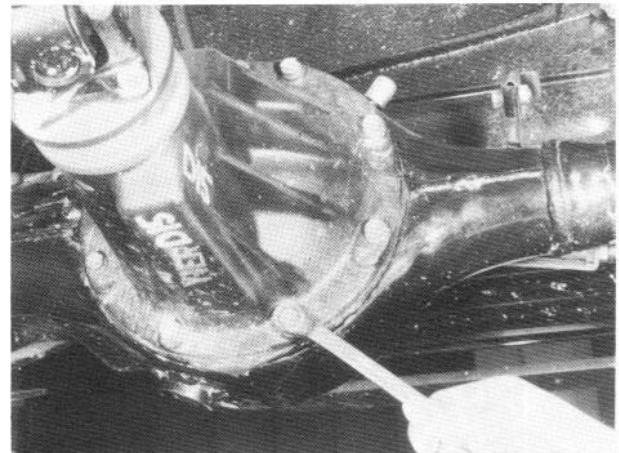
**Fig. 16-9-2** (I) *Plug*

Using special tools indicated below, draw out each axle shaft with brake backing plate.



**Fig. 16-10** (A) *Special tool (Rear axle remover 09922-66010)*  
 (B) *Special tool (Sliding hammer 09942-15510)*

Disconnect propeller shaft as in the case of front axle, and detach and take down differential carrier case from housing by removing 8 bolts.



**Fig. 16-11**

### 16-3. DISASSEMBLY

Lock flange immovable by using special tool, and remove nut from the end of bevel pinion shank.

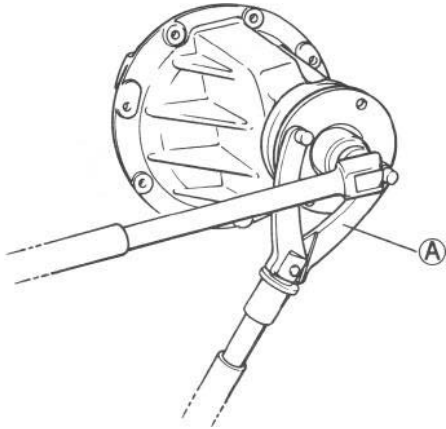


Fig. 16-12 (A) Special tool (Rotor holder 09930-40 113)

Scribe marks on each cap bolted to the saddle portion of carrier case and holding down the side bearing. The marks are to identify caps. This means that there are right and left caps, so identified and so handled at the time of reassembly.

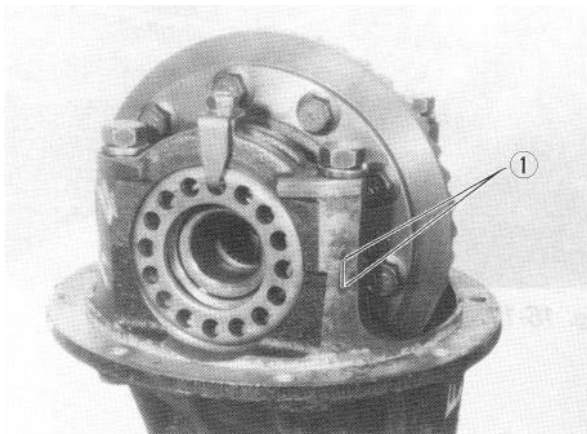


Fig. 16-13 (1) Scribed match marks

At each side, loosen bolts on bearing adjuster stopper, remove bearing cap securing bolts, and take off cap. Lift differential case assembly, complete with bevel gear, off the carrier.

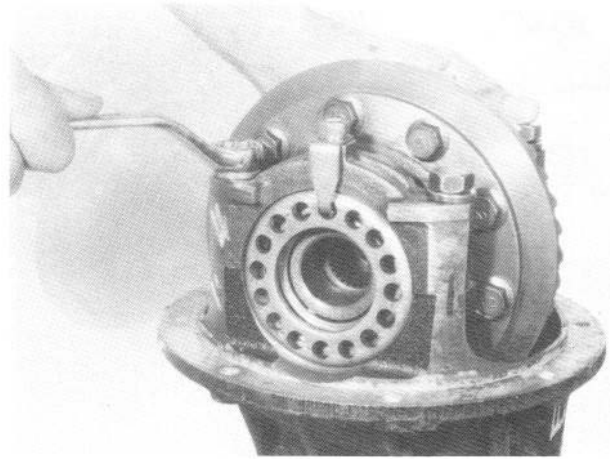


Fig. 16-14

Remove 10 bolts securing bevel gear to differential case, and separate gear from case.

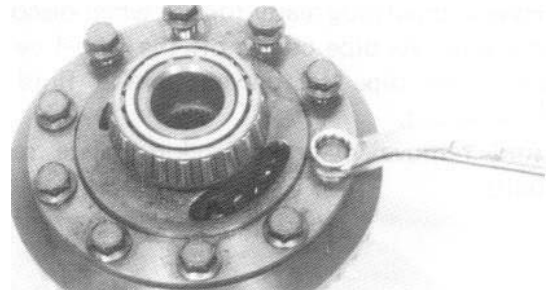


Fig. 16-15

There are 8 bolts fastening two differential case halves together. Remove these bolts to sever right-hand case half from left-hand one, and take off right-hand one.

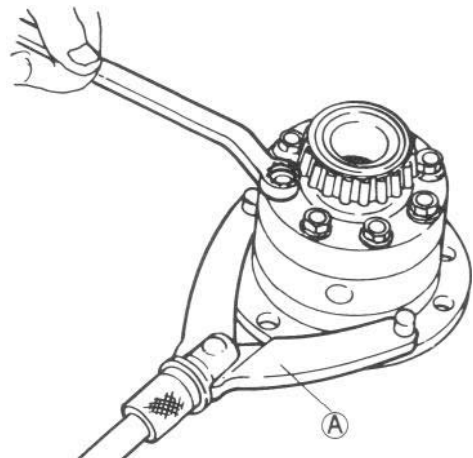
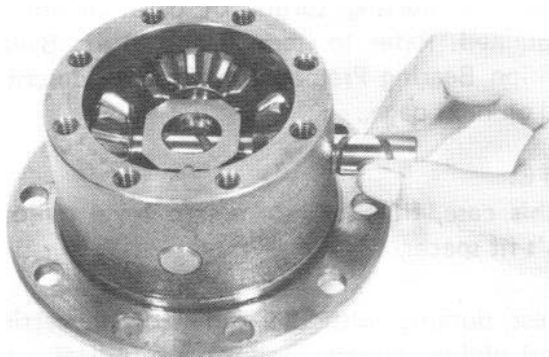


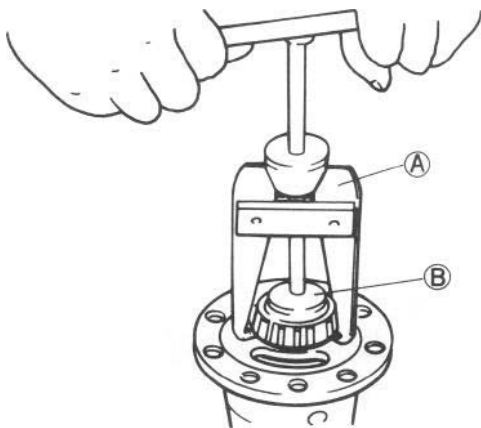
Fig. 16-16 (A) Special tool (Rotor holder 09930-40 113)

Remove side gears, differential pinions and thrust washers.



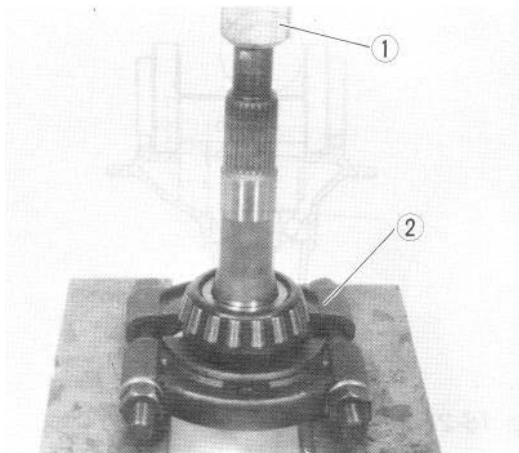
**Fig. 16-17**

Using special tools indicated below, extract side bearing from each differential case half.



**Fig. 16-18** **A** Special tool (Bearing puller 09913-60910)  
**B** Special tool (Side bearing removing jig 099 13-85230)

Using puller and hydraulic press, remove inner race of bevel pinion bearing.



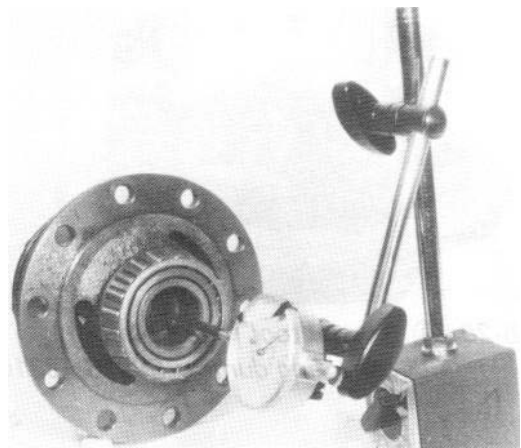
**Fig. 16-18-1** **1** Hydraulic press **2** Puller

## 16-4. INSPECTION AND ADJUSTMENT OF COMPONENTS

### Side Gear Thrust Play

To check thrust play, assemble differential gearing and case, as shown in Fig. 16-19, fastening together two case halves by tightening securing bolts to prescribed torque. By comparing thrust play reading, taken as shown in Fig. 16-19, against thrust play indicated below, increase or decrease total thickness of thrust washers, which are located in two places, that is, on the inner side of each case half.

Side gear thrust play specification	0.12 — 0.37 mm (0.005 — 0.014 in)
Available thrust washer sizes (thickness)	0.9, 1.0, 1.1 & 1.2 mm (0.035, 0.039, 0.043 & 0.047 in)

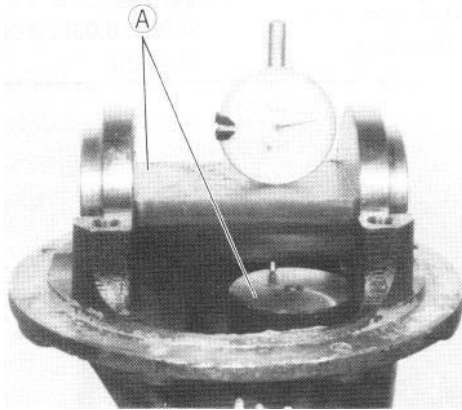


**Fig. 16-19**

**Determination of Shim Thickness for Bevel Pinion**

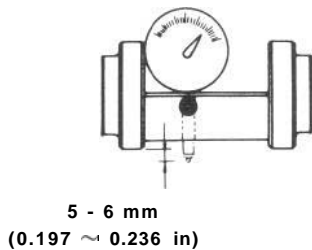
Thickness of shims to be used on the bevel pinion varies from one vehicle to another on account of factors involved in machining and assembling. Thus, for each vehicle, the thickness of shims necessary for locating pinion in correct position (for producing a proper backlash in the mesh between pinion and gear) must be determined anew at the time of reassembly.

In order to facilitate this determination, a 2-piece dummy tool (special tool) is made available. Following procedure is based on use of this tool and supposes that pinion dummy (one of the two pieces) is set in carrier, without any shims, as shown in Fig. 16-20.



**Fig. 16-20** A) Special tool (Bevel pinion mounting dummy 09926-78310)

- 1) Set dial indicator on dummy, letting the indicator spindle protrude 5 to 6 mm from the bottom of dummy as shown in Fig. 16-21-1.



**Fig. 16-21-1**

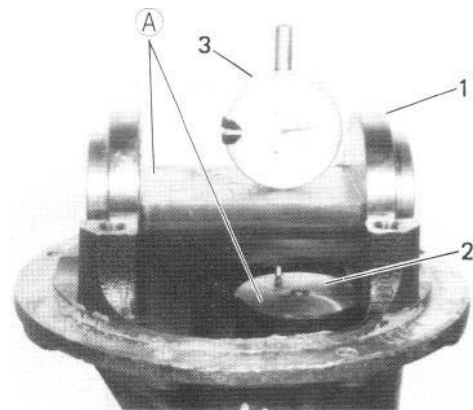
- 2) Feed dummy pinion with bearings into the carrier, positioning it properly, and install joint flange.

And then tighten bevel pinion nut until specified starting torque of bevel pinion is obtained. Refer to item 2) and 3) of "Bevel Pinion Bearing Preload Adjustment" described on next page.

**NOTE:**

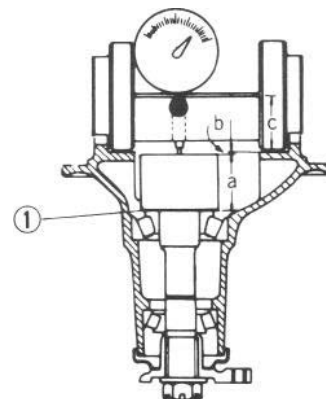
In this case, fit only bearings to bevel pinion. Don't fit spacer.

- 3) Rest dummy with dial indicator on carrier and pinion dummy, and set dial indicator to zero.



**Fig. 16-21-2** 1) Dummy 2. Pinion dummy 3) Dial indicator

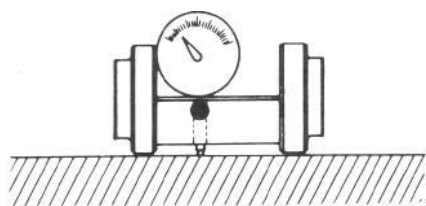
- 4) Referring to Fig. 16-21-3, note that three dimensions are involved: "a" "b" and "c". The value of "b" is unknown, and is to be determined now for calculating the required thickness of shims. The values of "a" and "c" are given: the sum, "a" + "c" is 94 mm, which is indicated on the dummy tool.



**Fig. 16-21-3**



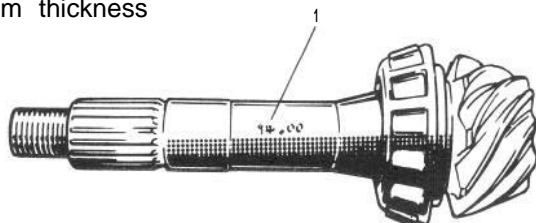
Rest dummy with dial indicator on surface plate, and the dial indicator pointer may have deflected from "0" mark to show a certain value; read this value, which is "b".



SURFACE PLATE

**Fig. 16-21-4**

Add this reading to 94 mm (= "a" + "c") and, from the sum, subtract the value marked on bevel pinion. The remainder is required shim thickness:  $(94 + "b") - \text{marked value} = \text{required shim thickness}$



**Fig. 16-22** 1. Marked value

5) Shim stock is available in twelve selective thicknesses. Select one or two shim(s) from the below to obtain the closest thickness to above required thickness, and insert selected shim piece(s) into clearance indicated as Fig. 16-21-3 ①

Sizes of shims for bevel pinion	1.00, 1.03, 1.06, 1.09, 1.12, 1.15, 1.18, 1.21, 1.24, 1.27, 1.30 & 0.3 mm
	{ 0.039, 0.041, 0.042, 0.043, 0.044, 0.045, 0.046, 0.047, 0.048, 0.049, }
	{ 0.050 & 0.012 in. }

**Bevel Pinion Bearing Preload Adjustment**

The bevel pinion, as installed in normal manner in carrier, is required to offer a certain torque resistance when checked by using prescribed preload adjuster (special tool A) as shown in Fig. 16-23. This resistance is a "preload," which is due to the tightness of the two tapered roller bearings by which the pinion is held in the carrier. And this tightness is determined primarily by tightening torque of bevel pinion nut. Adjust preload of bevel pinion bearings as follows.

1) Install pinion bearings, spacer, bevel pinion, oil seal and universal joint flange to differential carrier.

At this time, be sure to apply gear oil to bearings lightly and grease to oil seal lip.

2) Tighten bevel pinion nut by hand, and install special tool to universal joint flange.

3) After turning pinion several times, tighten pinion nut gradually, while checking pinion starting torque with spring balance, and stop tightening when starting torque reaches specification given below.

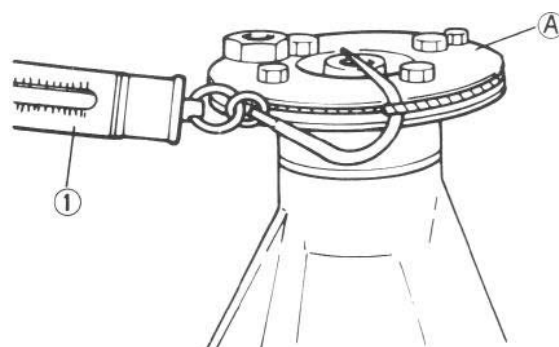
4) Caulk bevel pinion nut to prevent it from loosening.

**NOTE:**

Bevel pinion bearing preload is adjusted by tightening bevel pinion nut to crush spacer. Therefore, be sure to use a new spacer for adjustment and tighten pinion nut step by step and check for starting torque (preload) as often as tightening to prevent over crushing of spacer. If exceeds specification given below during adjustment, replace spacer and repeat preload adjustment procedure. Attempt to decrease starting torque (preload) by loosening pinion nut will not do.

The below data are not tightening torque of pinion nut but pinion bearing preload.

Pinion bearing preload	9.0 – 17.0 kg-cm (7.8 – 14.7 lb-in)
Starting torque (When using special tool)	1.8 – 3.4 kg (4.0 – 7.5 lb)



**Fig. 16-23** ① Spring balance

Ⓐ Special tool (Differential gear preload adjuster 09922-75221)

### Bevel Gear Backlash Adjustment

Backlash between bevel gear and pinion is checked as shown in Fig. 16-24. Note that differential case assembly is mounted in the normal manner, and fastened down by tightening the side bearing cap bolts to 1.0 – 2.0 kg-m (7.5 – 14.0 lb-ft). At this time, screw in each adjuster till it contacts bearing outer race so that outer race is prevented from inclining. The dial indicator spindle is pointed squarely to “heel” on drive side (convex side) of gear tooth. Hold bevel pinion rigidly, and turn gear back and forth.

The dial indicator reading, which is bevel gear backlash, must be within this range:

Bevel gear backlash	0.10 – 0.15 mm (0.004 – 0.006 in.)
---------------------	---------------------------------------

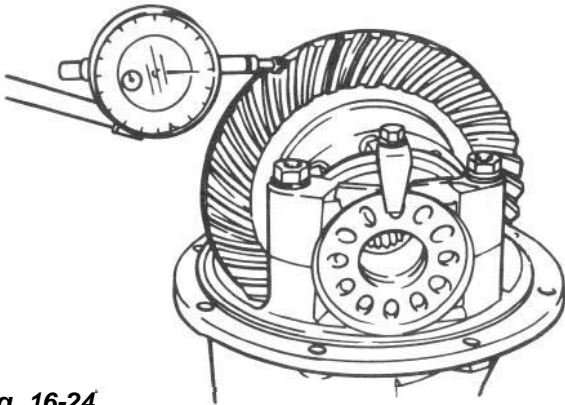


Fig. 16-24

To increase or decrease backlash for adjustment, displace bevel gear toward or away from pinion by running in one adjuster and running out the other adjuster by equal amount.

Turning the adjuster one notch changes backlash by about 0.05 mm (0.002 in.).

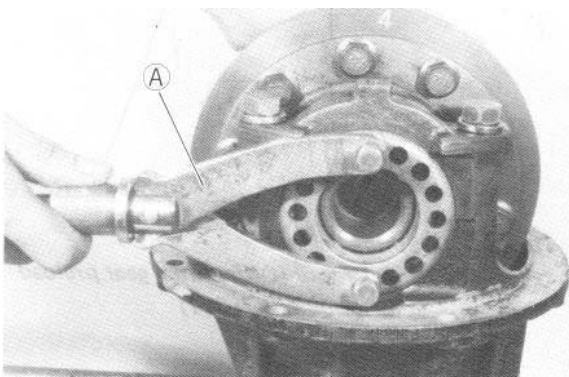
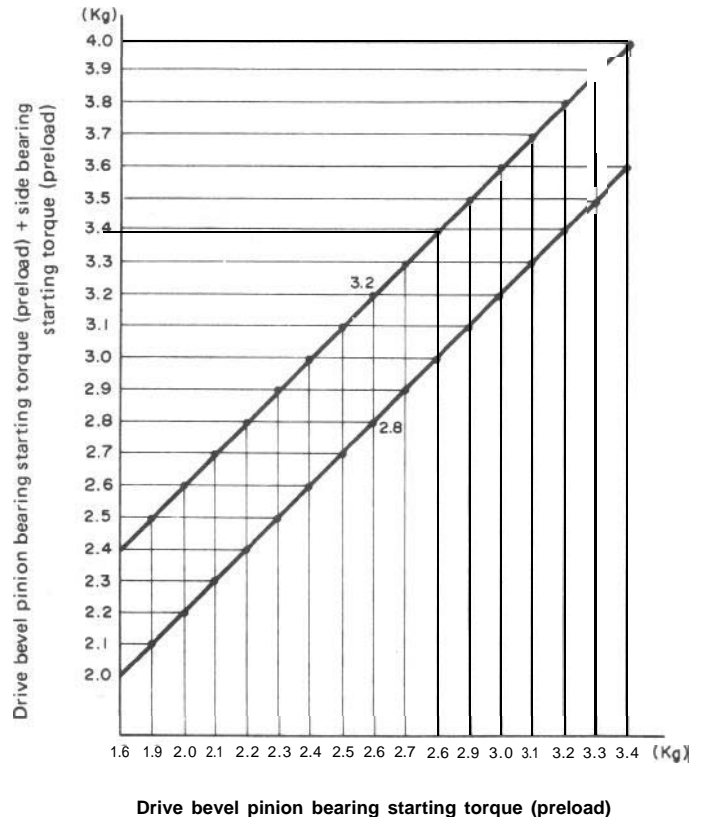


Fig. 16-25 (A) Special tool (Rotor holder 09930-40113)

### CAUTION:

- Adjust preload on side bearing during back-lash adjustment: mount special tool on drive bevel pinion as shown in Fig. 16-23 and measure using spring balance ①. If reading at the instant bevel gear starts moving is within the range given below, side bearing preload is acceptable. Referring to the graph, for example, when the drive bevel pinion bearing preload measured as shown in Fig. 16-23 is 2.6 kg (5.73 lb), drive bevel pinion bearing preload (kg) + bevel gear side bearing preload (kg) should be 2.8 – 3.2 kg (6.17 – 7.05 lb).
- Upon completion of this adjustment, be sure to tighten bearing cap bolts to 7.0 – 10.0 kg-m or 51.0 – 72.0 lbft.



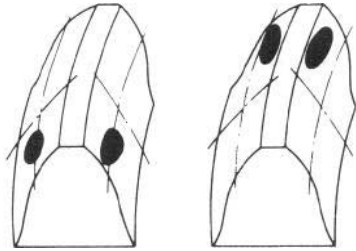
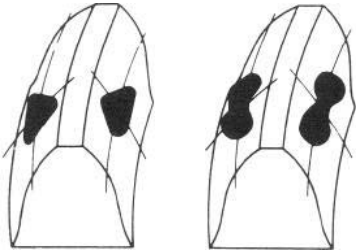
**Pinion-to-gear Tooth Contact Pattern Check and Adjustment**

In addition to proper backlash, proper tooth contact must be secured in the mesh of bevel pinion and gear, so that there will be no “gear noise” coming from the axle and that the hypoid teeth will not be overstressed in transmitting drive.

After the specified amount of backlash has been secured, check the pinion and gear for tooth contact by “rolling” contact patterns in a manner consistent with the standard shop practice: use a red lead paste to paint ten teeth, both drive side and coast side, of the gear, turn the gear back and forth by hand while holding the pinion in a “braking” manner, and examine the contact patterns in reference to the following chart:

	Contact patterns	Diagnosis, and what to do
Normal contact pattern		<p>Contact is roughly centered and somewhat more displaced toward toe than toward heel on both drive side (concave) and coast (convex) side.</p>
Patterns due to improper shim adjustment		<p><b>High contact:</b> Contact is on heel (drive side) and on toe (coast side). This condition means that the pinion is too far back and must be brought forward by increasing its shim thickness used in “mounting distance” adjustment.</p>
		<p><b>Low contact:</b> Contact is on toe (drive side) and on heel (coast side). This condition means that the pinion is too far out from the carrier and must be backed away by decreasing its shim thickness.</p>
Pattern due to defective parts		<p>These contact patterns indicate that the “offset” of differential carrier is too much or too little. The remedy is to replace the carrier with a new one.</p>



	Contact patterns	Diagnosis, and what to do
Patterns due to defective parts		<p>These contact patterns, located on toe or heel on both drive and coast sides, mean that 1) both pinion and gear are defective, 2) carrier is not true and square, or 3) gear is not properly seated on differential case. The remedy is to replace the defective member.</p>
		<p>Irregular patterns: If the pattern is not oval, it means that bevel gear is defective. High or low spots on tooth surfaces or on the seat of bevel gear are the cause of irregular patterns appearing on some teeth. The remedy is to replace the pinion and-gear set and, if the seat is defective, so is differential case.</p>

**CAUTION:**

When applying red lead paste to teeth, be sure to paint tooth surfaces uniformly. The paste must not be too dry or too fluid.

## 16-5. REASSEMBLY

Reverse disassembly procedure for reassembly, noting the following.

### NOTE:

Bevel pinion and bevel gear are supplied as a set. Even when only bevel pinion or bevel gear replacement is necessary, be sure to replace both as a set.

### Differential Pinion Shaft (Shorter)

When installing shaft into differential case and pinion, insert its "A" side into pinion joint.

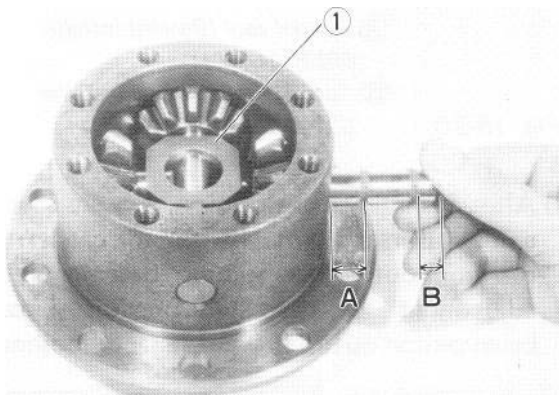


Fig. 16-26 ① Pinion joint  
 $A > B$  ("A" is longer than "B".)

### Drive Bevel Gear Bolts

Bolts securing bevel gear to differential case are subject to shear stress since drive is transmitted by these bolts from gear to case. For this reason, they are special bolts made from chrome steel and must never be replaced by common bolts.

When mounting gear onto case, be sure to apply **THREAD LOCK CEMENT SUPER 1333B (99000-32020)** to these bolts before running them in.

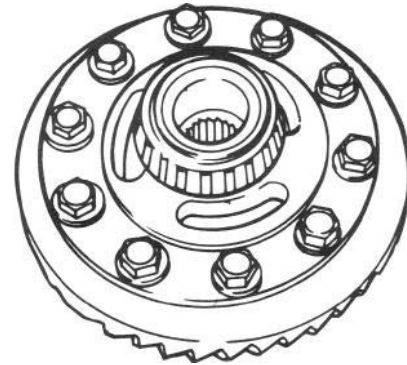


Fig. 16-26-1

### Differential Side Bearings

Press-fit these bearings into differential case by using special tool. Driving the bearing into case is not permitted.

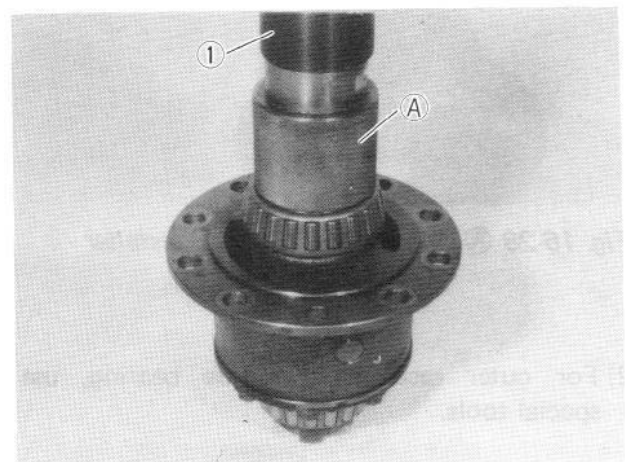


Fig. 16-27

- ① Press
- Ⓐ Special tool (Bearing installer 09940-53111)

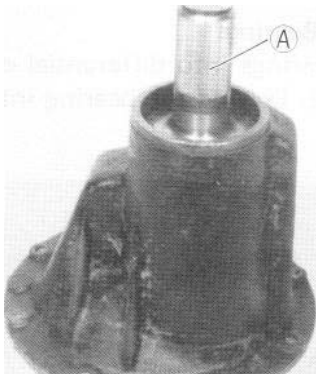
### Bevel Pinion Bearings

A press must be used to install two tapered roller bearings on bevel pinion. Outer races are press-fitted into the differential carrier and inner races onto the pinion.

#### NOTE:

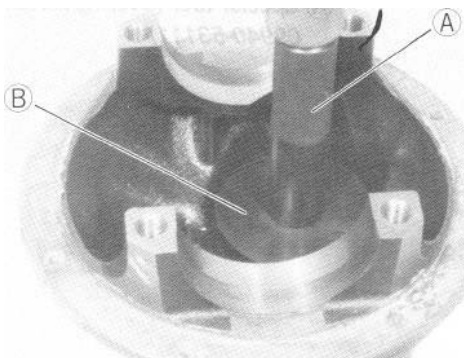
When replacing bevel pinion bearings, check to ensure that gear side and flange side bearings are the same maker's products.

- 1) For outer race of flange side bearing, use special tool as shown below.



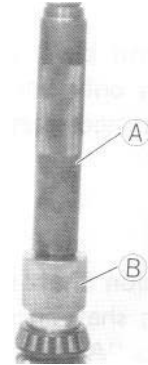
**Fig. 16-28** (A) Special tool (Bearing installer 09913-75510)

- 2) For outer race of gear side bearing, use special tools.



**Fig. 16-29** (A) Special tool (Bearing installer attachment 09924-74510)  
(B) Special tool (Bearing installer 09926-683 10)

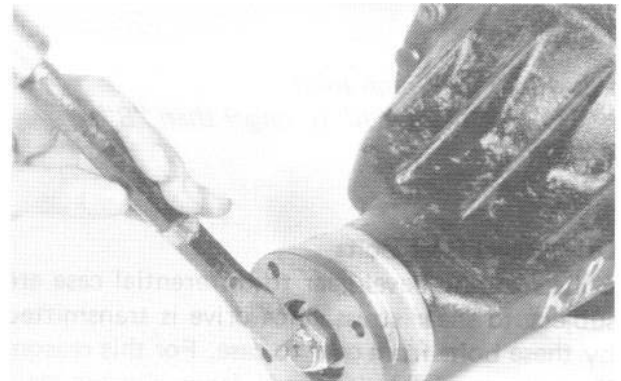
- 3) After installing proper bevel pinion shim(s), press-fit inner race to bevel pinion using special tools.



(A) Special tool (Bearing installer 09925-18010)  
(B) Special tool (Bearing installer 09940-53111)

**Fig. 16-30**

- 4) After installing bevel pinion, spacer, bearings and universal joint flange to carrier and carrying out "bevel pinion bearing preload adjustment" as described previously, caulk bevel pinion nut to prevent it from loosening.



**Fig. 16-30-1**

### Side Bearings Caps

When putting on side bearing caps, be sure to discriminate the right-hand cap from the left-hand one by referring to match marks scribed at the time of disassembly.

Then, after carrying out "Bevel gear backlash adjustment" as described on p. 16-10 torque cap bolts to specification.

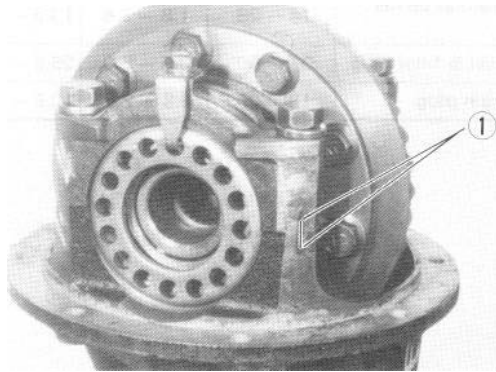


Fig. 16-31 ① Scribed match marks

## 16-6. INSTALLATION

Reverse removal procedure for installation, noting the following.

### Differential

Before installing differential ass'y to axle housing, clean mating surfaces of differential carrier and housing and apply sealant to them.

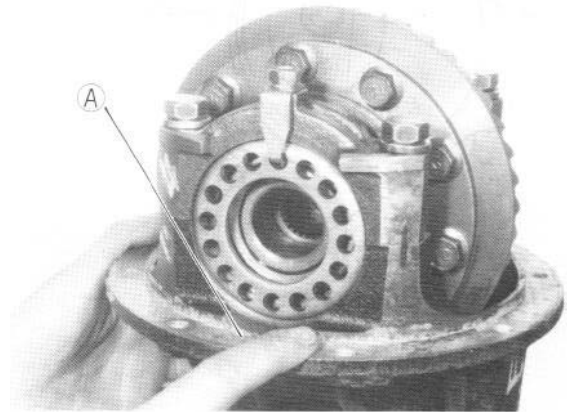


Fig. 16-32 ② Sealant (SUZUKI BOND NO. 1215 99000-31110)

### Front Axle Shaft and Steering Knuckle

For installation them, refer to "Front Suspension Installation" in SECTION 17 of this manual.

### Rear Brake Drum

For installation of rear brake drum, refer to "Rear Brake Installation" in SECTION 19 of this manual.

### Differential Gear Oil

Refill differential housing with new specified oil. Refer to "MAINTENANCE SERVICE" in this section for refill.

### Brake Circuit Air Purging

If brake pipe (right & left) was disconnected from wheel cylinder as in Fig. 16-9-2, make sure to purge air out of brake circuit. Refer to section 19. BRAKES for "air purging" operation. Then check to ensure that joint seam of pipe is free from oil leak.

## 16-7. MAINTENANCE SERVICES

### Inspection

Inspect differential and differential housing for evidence of oil leakage.

Oil level is checked by means of its oil level plug. Refer to p 1-20 for level inspection,

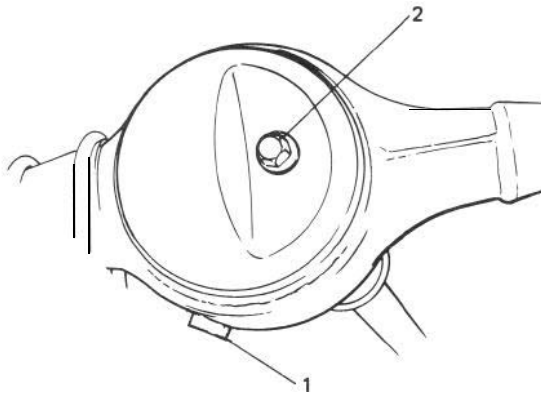


Fig. 16-33 ① Drain plug  
② Oil level & filler plug

### Oil Change

- 1) Remove oil drain plug and drain oil.
- 2) Reinstall drain plug and tighten it to specified tightening torque.
- 3) Remove oil level & filler plug and fill differential housing with new specified oil.

Differential oil specification		Hypoid gear oil SAE 80W-90, 75W-80 or 75W-90
Oil capacity	Front	2.0 litres (4.2/3.5 US/Imp pt.)
	Rear	1.5 litres (3.2/2.6 US/Imp pt.)

It is highly recommended to use SAE 75W-90 gear oil.

For viscosity chart, refer to P. 1-20.

- 4) Reinstall oil level & filler plug and tighten it to specified tightening torque.

## 16-8. RECOMMENDED TORQUE SPECIFICATIONS

Fastening parts	Tightening torque		
	N-m	kg - m	lb-ft
Side bearing cap bolt	70 - 100	7.0 - 10.0	51.0 - 72.0
Drive bevel gear bolt	80 - 90	8.0 - 9.0	58.0 - 66.0
Differential case bolt	37-45	3.7 - 4.5	27.0 - 32.5
Side bearing adjuster lock bolt	9 - 14	0.9 - 1.4	7.0 - 10.0
Differential carrier bolt	18 - 28	1.8 - 2.8	13.5 - 20.0
Oil level & filler plug	35 - 50	3.5 - 5.0	25.5 - 36.0
Oil drain plug	18 - 25	1.8 - 2.5	13.5 - 18.0

# SECTION 17

## SUSPENSION

### CONTENTS

17-1. FRONT SUSPENSION.....	17-2
17-2. REAR SUSPENSION .....	17-15
17-3. MAINTENANCE SERVICES.....	17-20
17-4. RECOMMENDED TORQUE SPECIFICATIONS.....	17-26
17-5. FRONT FREE WHEELING HUB (OPTIONAL) .....	17-27

**NOTE:**

- 1 All suspension fasteners are an important attaching part in that it could affect the performance of vital parts and systems, and/or could result in major repair expense. They must be replaced with one of the same part number or with an equivalent part if replacement becomes necessary. Do not use a replacement part of lesser quality or substitute design. Torque values must be used as specified during reassembly to assure proper retention of this part.
- 1 Never attempt to heat, quench or straighten any suspension part. Replace it with a new part, or damage to the part may result.
- 1 The leaf spring number or shape shown in this manual may differ from the car being actually serviced, depending on specification.

## 17-1. FRONT SUSPENSION

### GENERAL DESCRIPTION

The front suspension consists of the double-acting shock absorbers, stabilizer bar, semi-elliptical leaf springs, axle housing, etc. as shown below.

The Barfield universal joints are used in the front axle to enable the axle shafts to drive the front wheels while allowing the wheels to be steered. This type of joint provides for a larger steering angle range and, what is more important, constant-velocity drive to the wheel.

If a single two-yoke (or Hooke's) universal joint is used to connect the axle shaft to the wheel on each side of the front end, the wheels will run with the same speed, but not with the same constant velocity, as that of the axle shafts when the wheels are turned around their kingpins for steering action. The Barfield joint transmits drive without varying the angular velocity of drive.

The Barfield joint is enclosed by the knuckle, which is shaped integral with the knuckle arm, and has a two-piece kingpin, namely, upper and lower kingpins.

The end of the dead axle sleeve is in the shape of dish. This dish is rotatably fitted into the knuckle structure to form a flexible connection, the sliding clearance between the two being sealed with a felt packing (against road dust and mud) and also with an oil seal (against the oil inside). The upper and lower kingpins, bolted to the knuckle extend into the knuckle and, inside, are held by the dish-like inner case through tapered roller bearings.

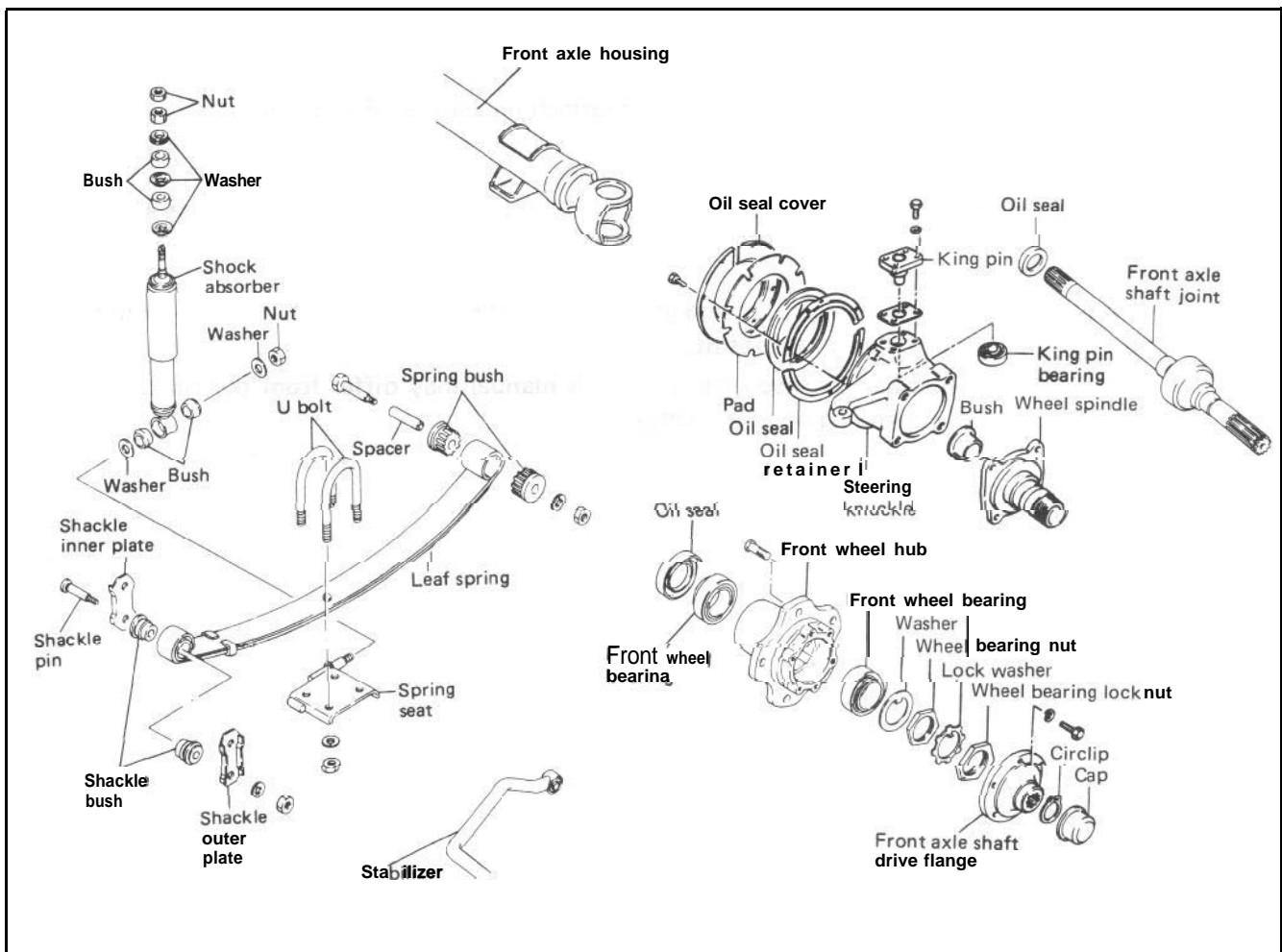
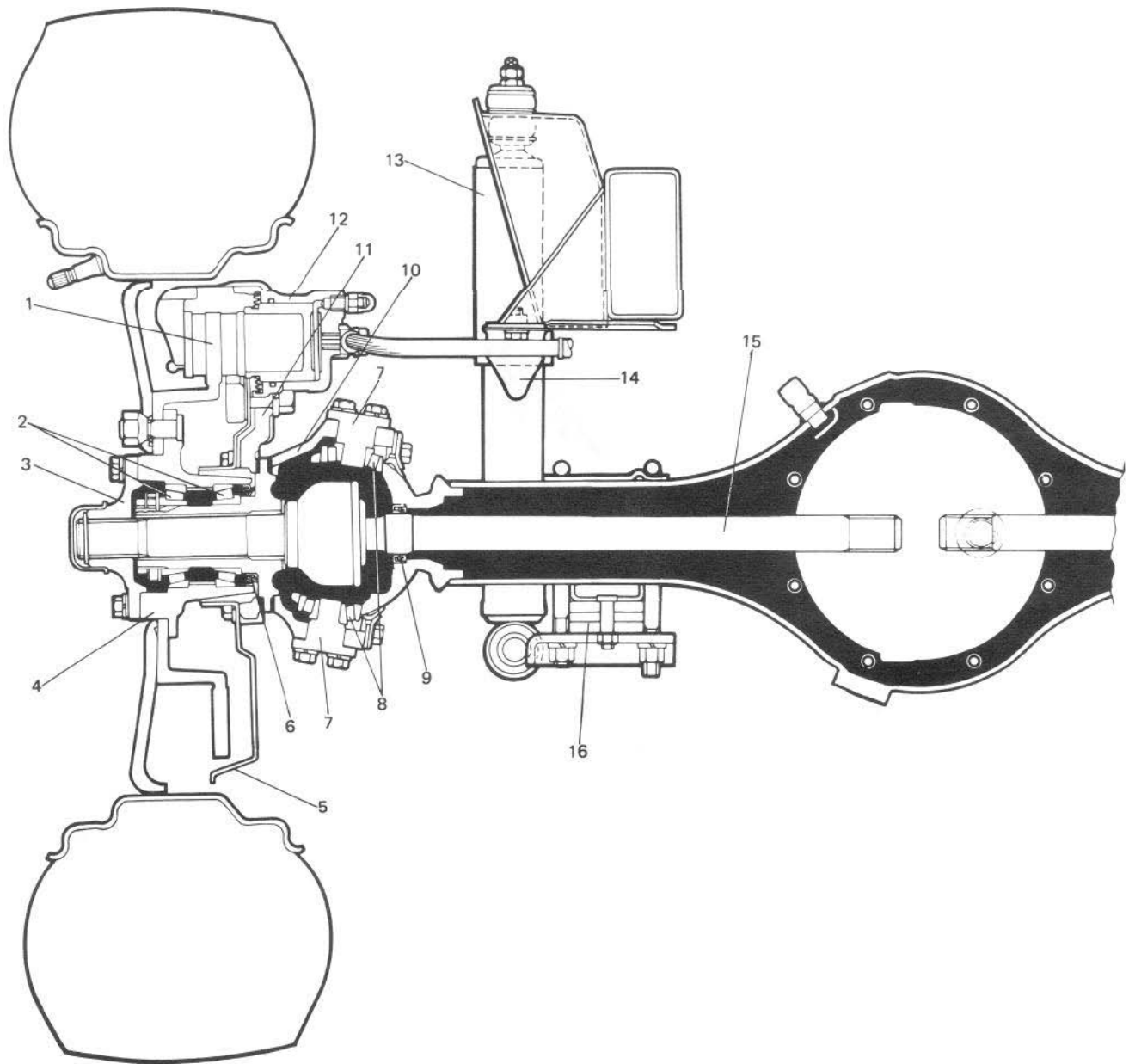


Fig. 17-1-1



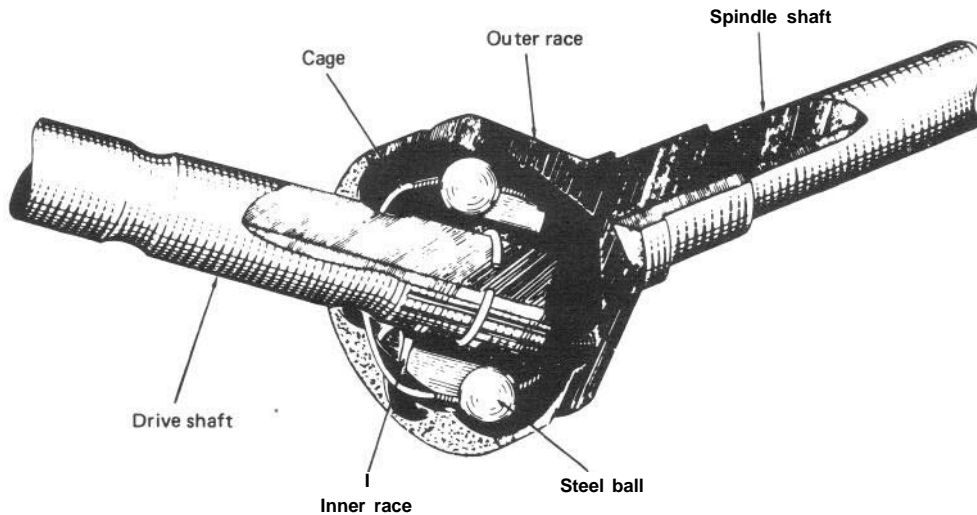
**Fig. 17-1-2**

- |                            |                        |
|----------------------------|------------------------|
| 1. Front brake disc        | 9. Oil seal            |
| 2. Wheel bearing           | 10. Steering knuckle   |
| 3. Axle shaft drive flange | 11. Disc brake holder  |
| 4. Wheel hub               | 12. Disc brake caliper |
| 5. Dust cover              | 13. Shock absorber     |
| 6. Oil seal                | 14. Spring bumper      |
| 7. King pin                | 15. Axle shaft joint   |
| 8. King pin bearing        | 16. Leaf spring        |



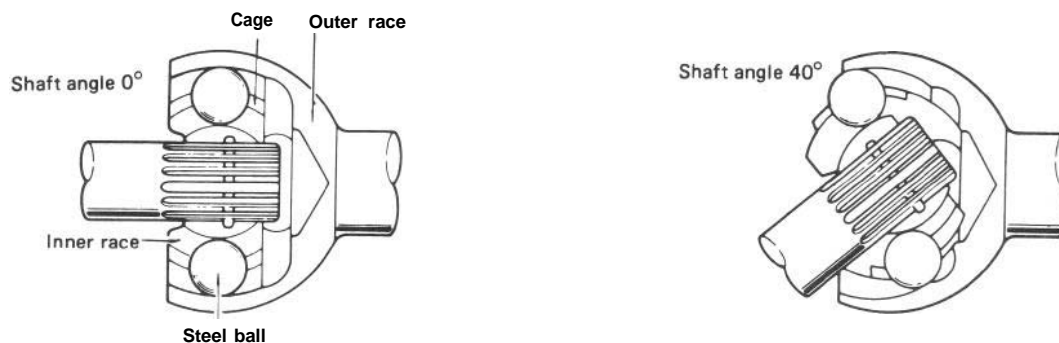
### BARFIELD JOINT CONSTRUCTION AND OPERATION

The major parts of the Barfield joint are the outer race (integral with wheel spindle, to which the wheel disc is splined), inner race (splined to the live axle shaft), six steel balls disposed between the two races, and cage (holding the steel balls in a single row lying in a plane).



**Fig. 17-1-3**

The balls are fitted in two groups of raceways; one group is on the outer race and the other group on the inner race. Each ball is in its own raceways as if it were locked between the two races in the direction of rotation. The outer race with its wheel spindle is capable of angling and, when it so angles with respect to the axis of axle shaft, the row of steel balls angles just half as much, that is, the plane including this row tilts by an angle equal to one-half of the spindle angle. This relationship is illustrated in Fig. 17-1-4.



**Fig. 17-1-4**

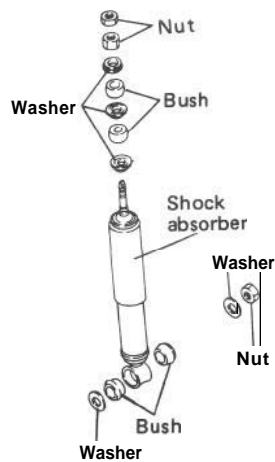
## REMOVAL

### Shock Absorber

The shock absorber is non-adjustable, non-refillable, and cannot be disassembled.

The only service the shock absorber requires is replacement when it has lost its resistance, is damaged, or leaking fluid.

1. Hoist car.
2. Loosen lower and upper mounting nuts and remove shock absorber.



**Fig. 17-1-5**

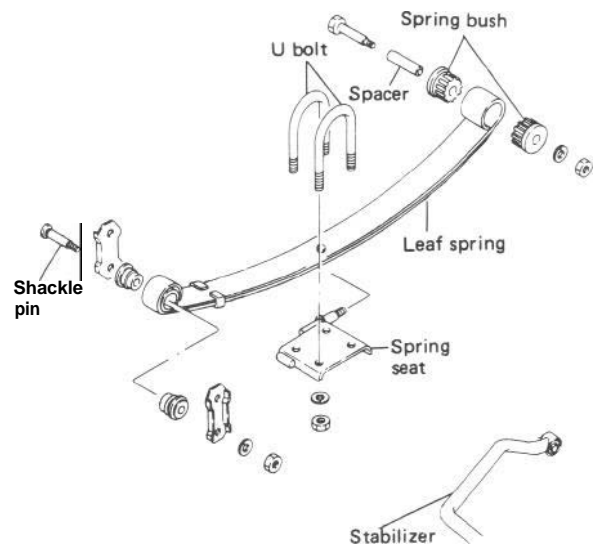
### Leaf Spring

1. Raise car. In this operation, garage jack or hoist must not be positioned against front suspension related parts. When garage jack is used, place safety stands under chassis to support raised body.
2. Remove front wheel.
3. Remove stabilizer bolt.
4. Remove U-bolt nuts.
5. Remove shackle nuts and leaf spring nut.

### NOTE:

Removal of leaf spring causes axle housing to hang. Support it with safety stand to prevent it from damaging universal joint of propeller shaft and others.

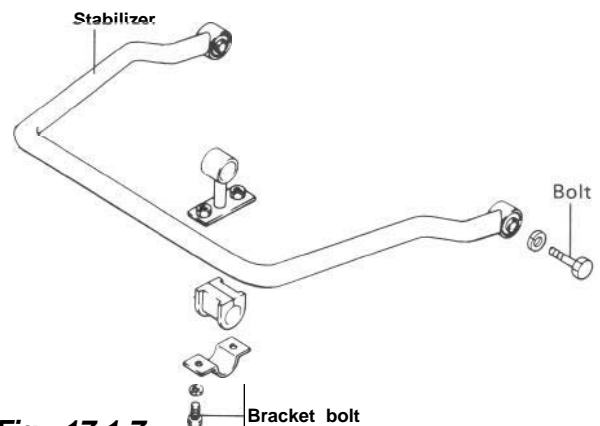
6. Pull out leaf spring bolt and remove leaf spring from shackle pin.



**Fig. 17-1-6**

### Stabilizer

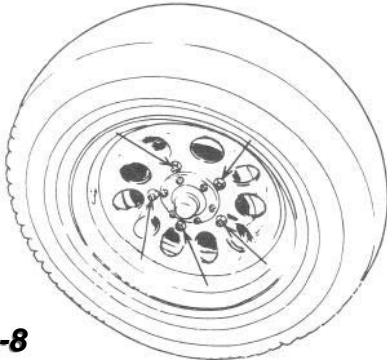
1. Hoist car.
2. Remove stabilizer bolts.
3. After removing stabilizer mount bush bracket bolts, remove stabilizer.



**Fig. 17-1-7**

### Front Wheel Hub & Bearing

1. Loosen the five nuts securing the wheel.  
Raise the front end by jacking.  
Rest the machine steady on safety stands.
2. Remove the five nuts and take off the wheel.

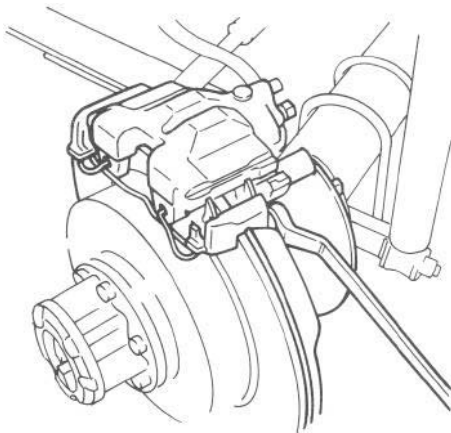


**Fig. 17-1-8**

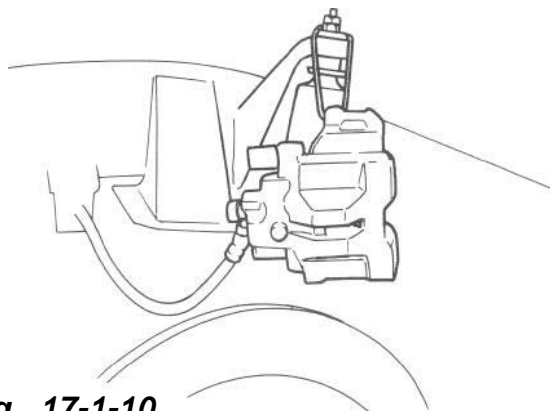
3. Remove the caliper with carrier by loosening carrier bolts.

#### NOTE:

Hang removed caliper with a wire hook or the like so as to prevent brake hose from bending and twisting excessively or being pulled.  
Don't operate brake pedal with caliper removed.



**Fig. 17-1-9**

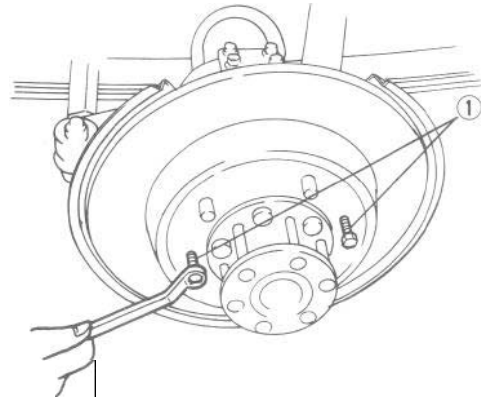


**Fig. 17-1-10**

4. Remove brake disc.

#### NOTE:

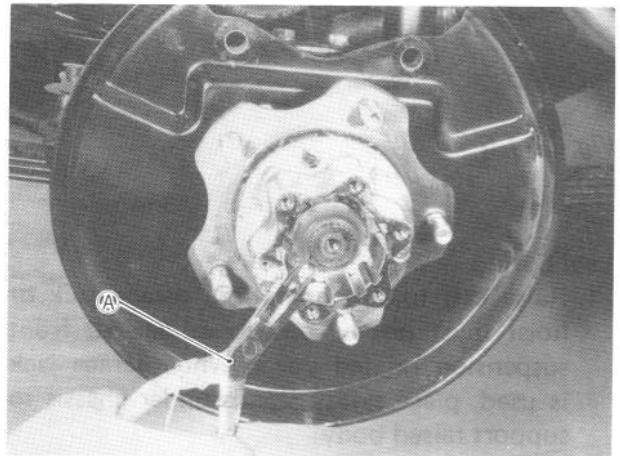
If brake disc can not be removed by hand, use 8 mm bolts as shown below.



**Fig. 17-1-11 ① 8mm Bolt**

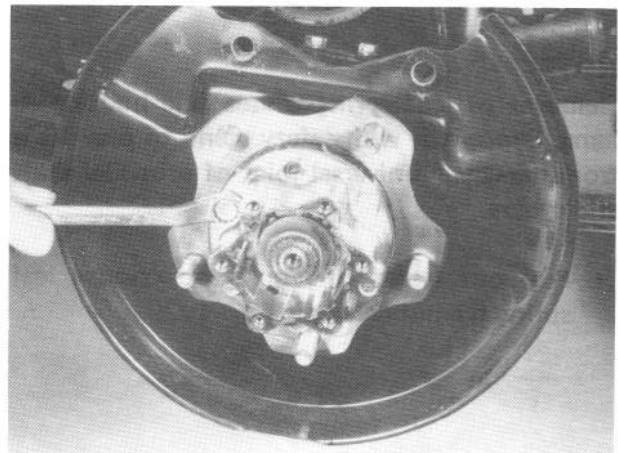
[For car equipped with free wheeling hub]

5. Remove free wheeling hub cover and circlip.



**Fig. 17-1-12-1 ① Circlip remover (09900-06107)**

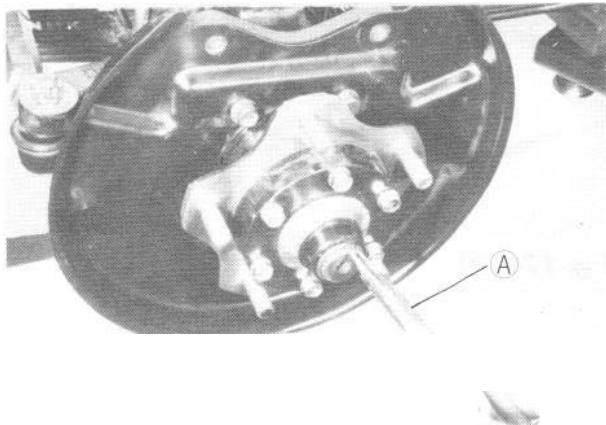
6. Remove free wheeling hub body.



**Fig. 17-1-12-2**

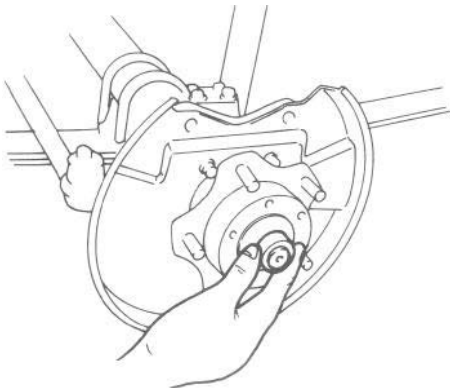
[For car not equipped with free wheeling hub]

5. Remove the front axle shaft cap.
6. Remove the circlip retaining the front axle shaft drive flange on front drive shaft, using the circlip remover (A).



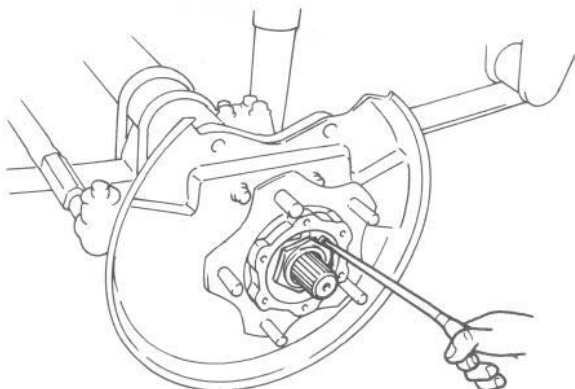
**Fig. 17-1-12-3 (A) Circlip Remover**

7. Loosen securing bolts of front axle shaft drive flange and take off drive flange.

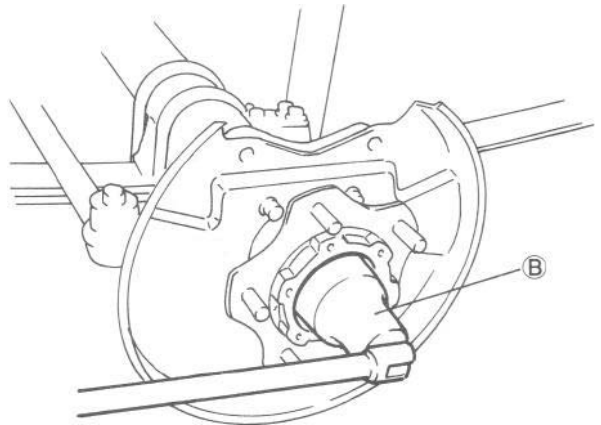


**Fig. 17-1-13**

8. Straighten bent part of lock washer and remove wheel bearing lock nut with special tool (B).

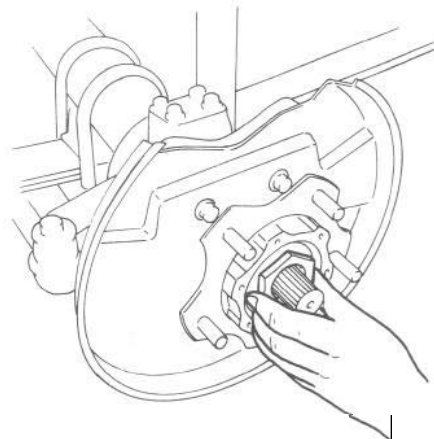


**Fig. 17-1-14**



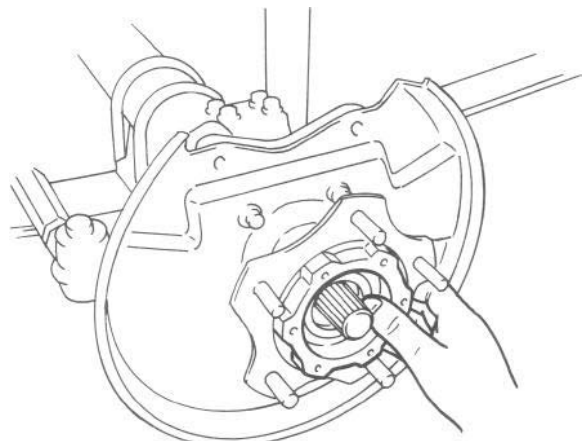
**Fig. 17-1-15 Special tool (B)  
(Front Wheel Bearing Nut Socket  
Wrench 09941-58010)**

9. After loosening front wheel bearing nut with the same special tool (B) as mentioned in the foregoing step 8, take nut and washer off the front wheel spindle.



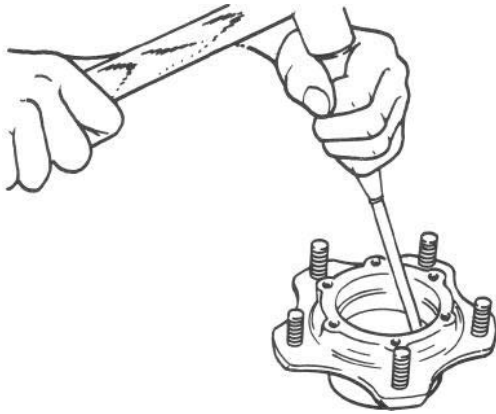
**Fig. 17-1-16**

10. Pull front wheel hub off the front wheel spindle.



**Fig. 17-1-17**

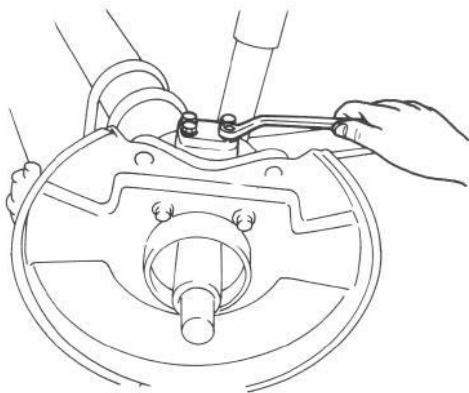
11. Remove oil seal and outer race of inner bearing or outer bearing from wheel hub.



**Fig. 17-1-18**

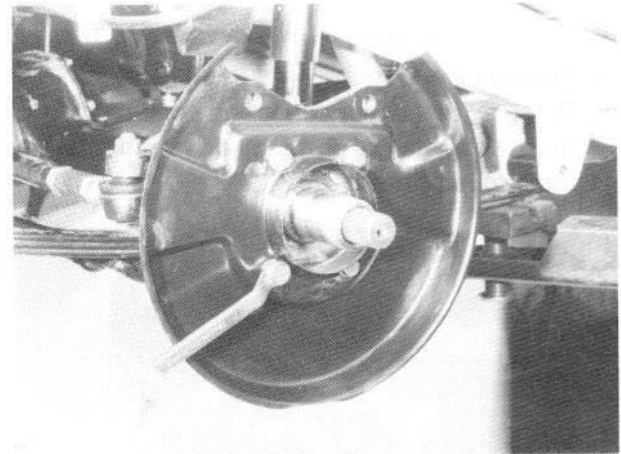
#### Steering Knuckle

1. Remove front wheel hub, referring to steps 1 to 10 of foregoing front wheel hub and bearing removal.
2. Loosen bolts securing kingpins (upper & lower). At this point, king pins mustn't be removed.



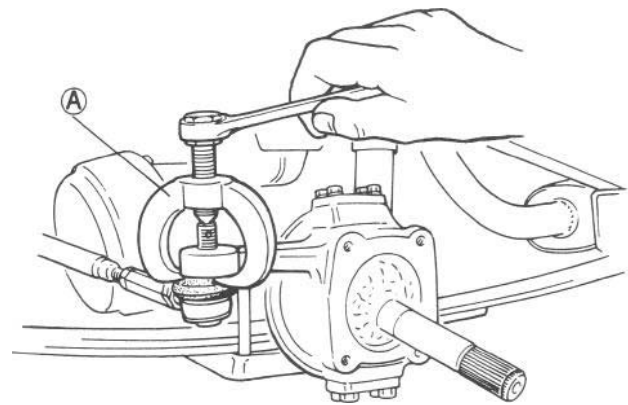
**Fig. 17-1-19**

3. Remove disc dust cover, caliper holder and wheel spindle.



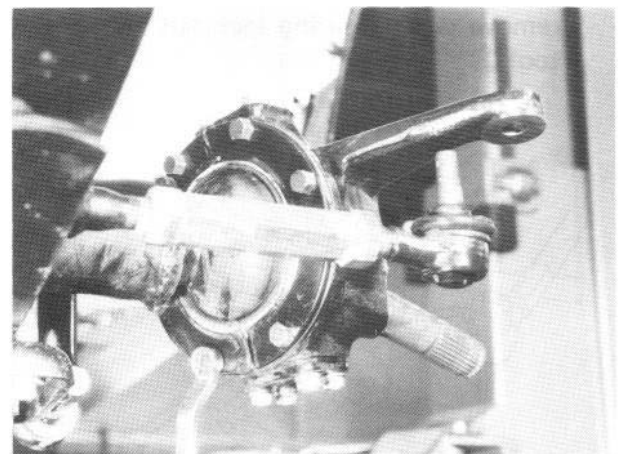
**Fig. 17-1-20**

4. Remove tie rod end castle nut and disconnect tie rod end from steering knuckle with special tool (A).



**Fig. 17-1-21 Special tool (A) (Tie Rod End Remover 09913-65210)**

5. Remove joint seal bolts. Then remove oil seal cover, pad, oil seal and retainer from knuckle.

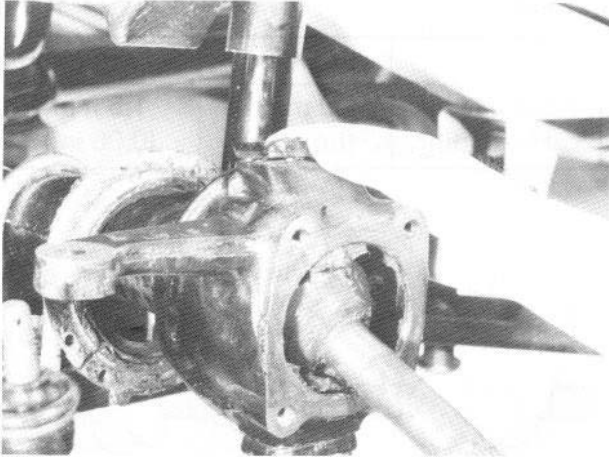


**Fig. 17-1-22**

6. Remove lower and upper kingpins.

**NOTE:**

- 1 Upper and lower kingpins, when removed, must be marked off one from the other.
- 1 Also make sure to check the number of kingpin shims that were fitted on each side.

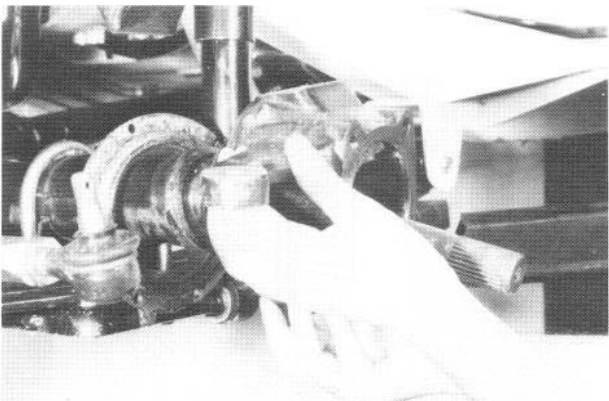


**Fig. 17-1-23**

7. Pull off steering knuckle,

**NOTE:**

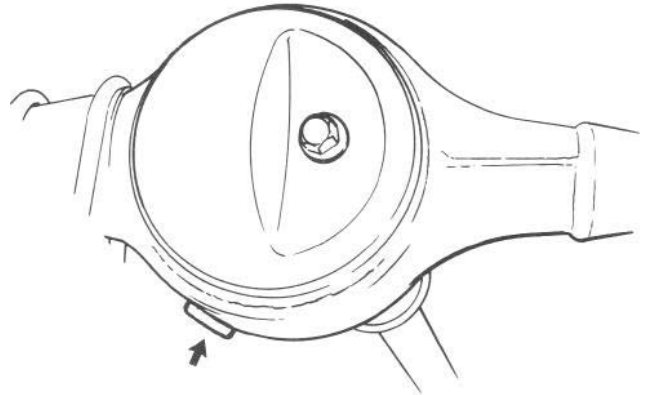
- When steering knuckle is pulled, lower kingpin bearing sometimes falls off. So remove bearing while pulling off the knuckle gradually.
- Upper and lower kingpin bearings must be also marked off one from the other.



**Fig. 17-1-24**

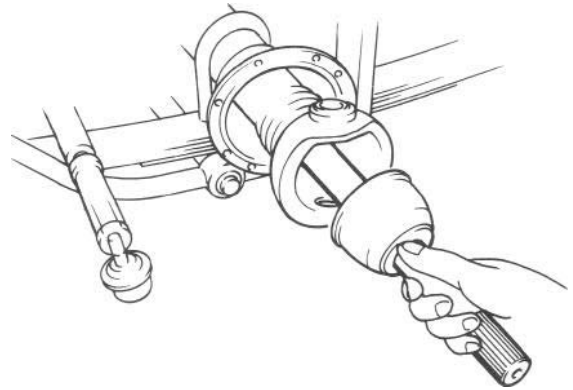
**Front Axle Shaft Joint**

1. To remove axle shaft joint, carry out steps 1 through 7 of steering knuckle removal (p. 17-8 and 17-9) and then follow steps 2 and 3 given below.
2. Drain oil from differential housing by loosening drain plug.



**Fig. 17-1-25**

3. Pull axle shaft joint off front axle housing.



**Fig. 17-1-26**

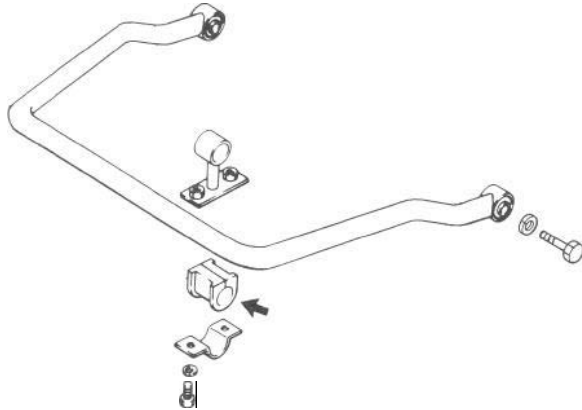


## INSPECTION OF COMPONENT

### Stabilizer and its Bush

Inspect stabilizer for damage or deformation. If defective, replace.

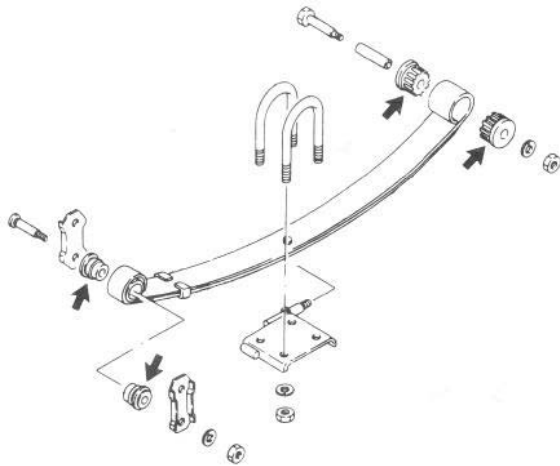
Inspect bushes for damage, wear or deterioration. If defective, replace.



**Fig. 17-1-27**

### Leaf Spring Bushes

Inspect for wear and breakage. If found defective, replace.

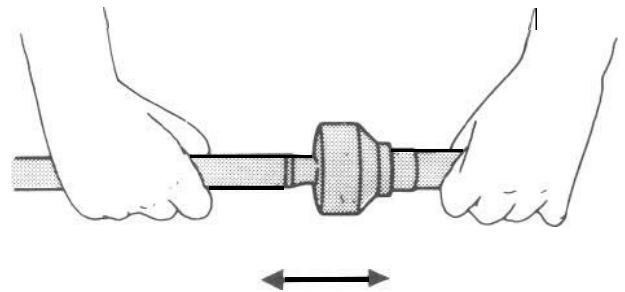


**Fig. 17-1-28**

### Barfield Joint

To be checked on this joint is its axial play, which shows up when a push-and-pull motion is given to live axle shaft and wheel spindle held in both hands, as shown in figure. There should be no play at all but a play of up to 1.5 mm (0.06 in.) is permissible. If play exceeds service limit, replace it.

	Standard	Service Limit
Axial play in barfield joint	0 mm (no play)	1.5 mm (0.06 in.)



**Fig. 17-1-29**

### Front Wheel Bearing

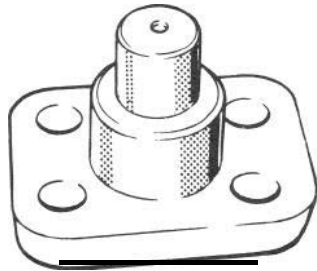
Check front wheel bearing rollers for damage. If anything is found wrong, replace bearing with a new one.



**Fig. 17-1-30**

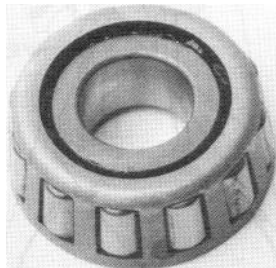
### **Kingpins and Bearings**

Inspect each kingpin closely for dents, signs of cracking, distortion or any other damage. Replace the kingpins found in defective condition.



*Fig. 17-1-31*

Check the kingpin bearings for damage. If anything is found wrong, replace the bearing with new one.

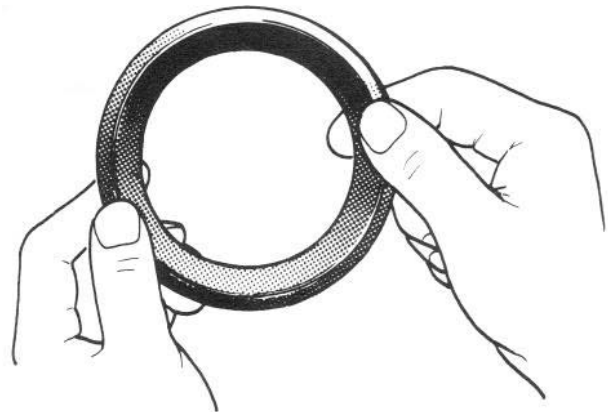


*Fig. 17-1-32*

### **Steering Knuckle Oil Seal**

The oil seal used at the spherical sliding joint between the knuckle and the inner case accomplishes the additional purposes of keeping out road dust and of acting as the damper for the steering handwheel. As the wear of this seal advances, its damping effect decreases and thus make the front wheel develop a tendency to “shimmy” not only that road dust begins to creep into the sliding clearance to promote the wear of the spherical sliding surfaces.

Check the oil seal for wear or damage. If defective, replace with new one.



*Fig. 17-1-33*



## INSTALLATION

Reverse removal procedure observing each precaution.

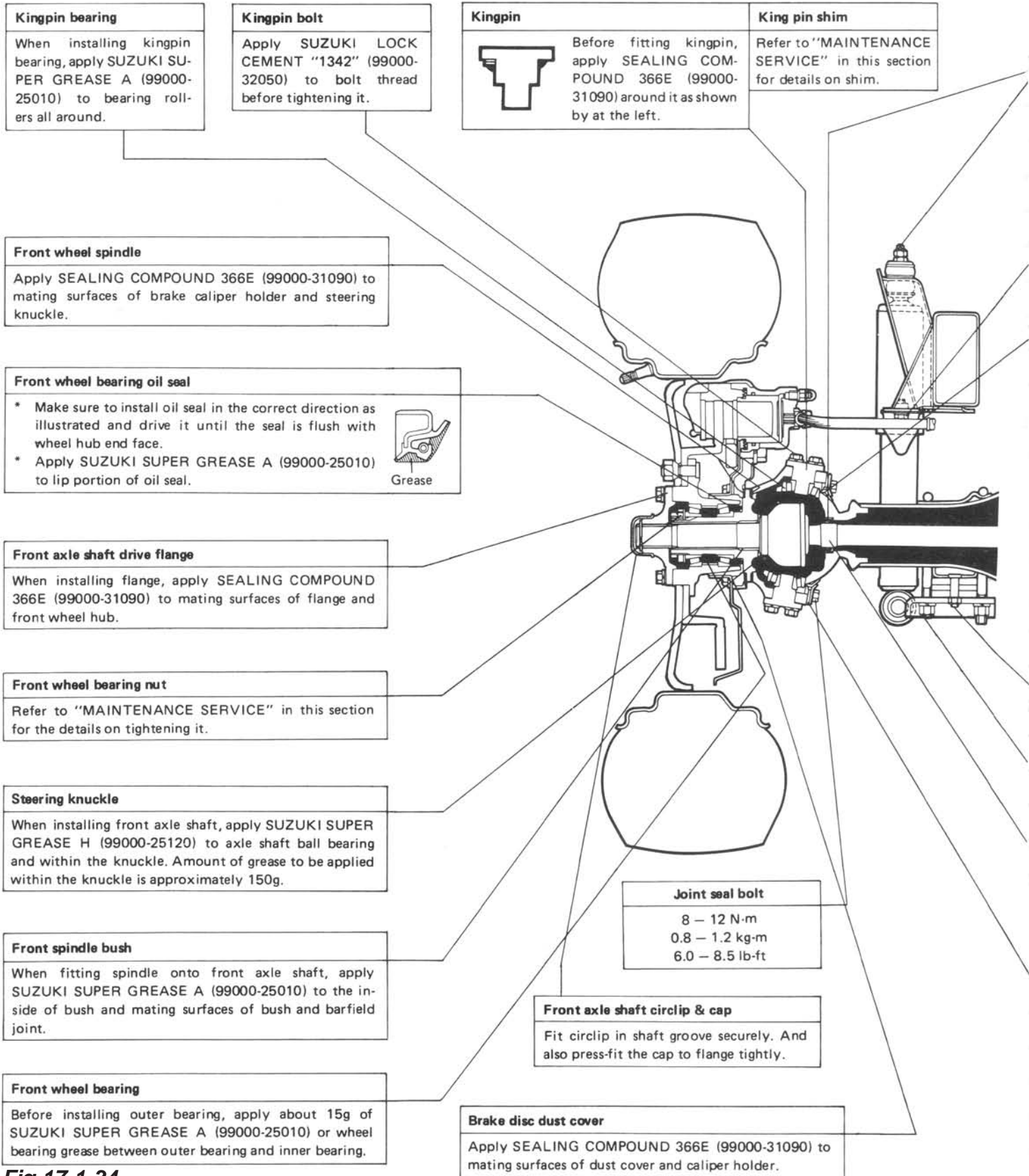


Fig 17-1-34

**Shock absorber lock nut**

22 – 35 N·m  
 2.2 – 3.5 kg·m  
 (16.0 – 25.0 lb·ft)

**Front axle shaft oil seal**

Grease

- \* Before installing oil seal, apply SUZUKI SUPER GREASE A (99000-25010) to its lip portion.
- \* Use care for correct installing direction, referring to the illustration.

**Spring bumper bolt**

18 – 28 N·m  
 1.8 – 2.8 kg·m  
 (13.5 – 20.0 lb·ft)

**Steering knuckle oil seal**

Grease

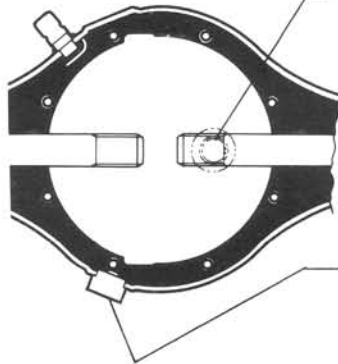
Before installing oil seal, apply SUZUKI SUPER GREASE A (99000-25010) to its lip portion.

**Oil level & filler plug**

35 – 50 N·m  
 3.5 – 5.0 kg·m  
 (25.5 – 36.0 lb·ft)

**Oil drain plug**

18 – 25 N·m  
 1.8 – 2.5 kg·m  
 (13.5 – 18.0 lb·ft)

**Leaf spring center bolt & nut**

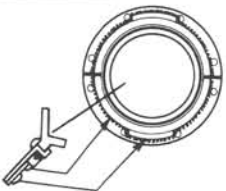
Insert bolt and nut securely into holes of axle housing seat and spring seat.

**Front spring U bolt**

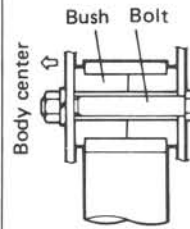
When securing U bolt, tighten its front and rear nuts evenly.

**Front axle shaft joint Ass'y**

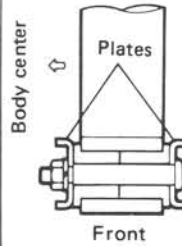
When inserting axle shaft into front axle housing, be careful not to cause any damage or distortion to axle shaft oil seal.

**Oil seal retainer**

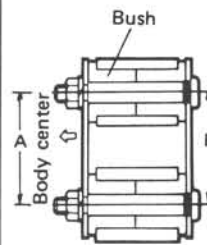
When installing retainer, apply SEALING COMPOUND 366E (99000-31090) all around it.

**Front leaf spring bush & spring bolt**

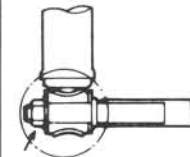
- \* Either water or household type detergent may be used to press-fit the bush onto spring. But oil of any kind is strictly prohibited.
- \* Insert both right and left bolts from the outside into the inside of body.

**Front leaf spring shackle plate**

Install plates with their backs directed to each other.

**Front leaf spring shackle pins & bush**

- \* Insert both right and left pins from outside into inside of body.
- \* Tighten nuts to specified torque in unloaded state.
- \* When pins are inserted, make sure that the difference (A – B) is within  $-0.3 \sim +0.3$  mm ( $-0.024 \sim +0.024$  in).
- \* Either water or household type detergent may be used to press-fit bush onto spring. But oil of any kind is strictly prohibited.

**Shock absorber & nut**

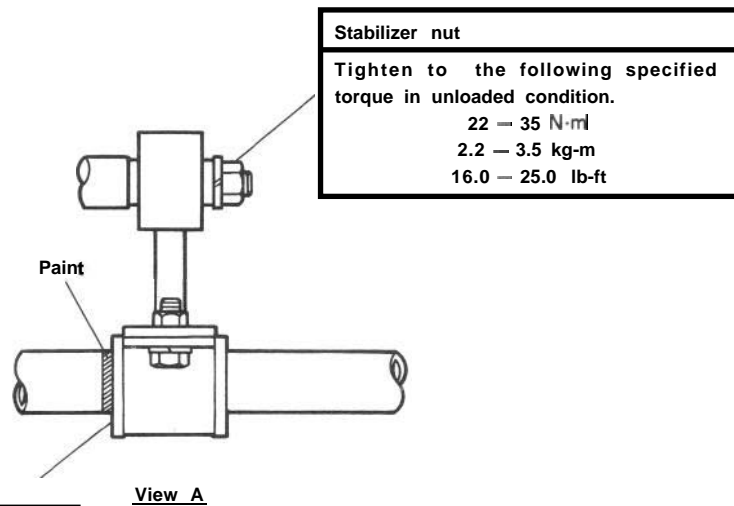
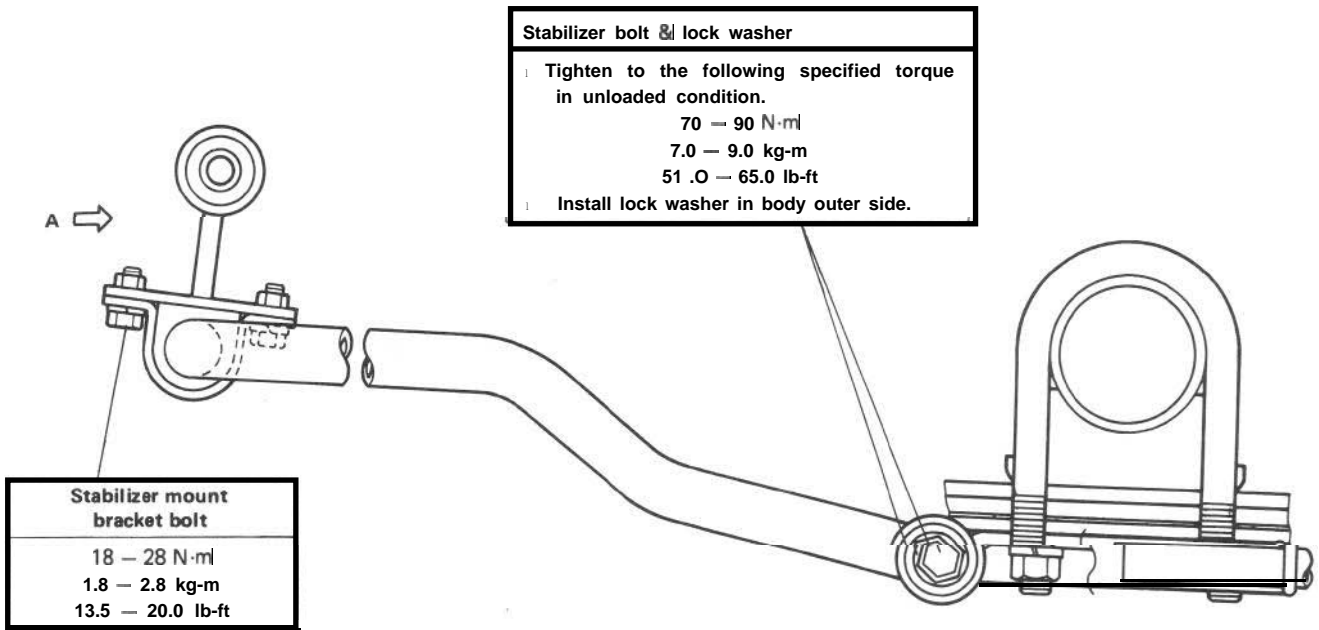
For correct installing direction of absorber washer, refer to the figure.

35 – 55 N·m  
 3.5 – 5.5 kg·m  
 (25.5 – 39.5 lb·ft)

**NOTE:**

Torque specifications of other bolts and nuts are given under "RECOMMENDED TORQUE SPECIFICATIONS" of this section.

# Stabilizer



**Stabilizer mount bush**

Install stabilizer mount bushes (right & left) by aligning them with painted positions on stabilizer respectively.

Fig. 17-1-35

## 17-2. REAR SUSPENSION

### GENERAL DESCRIPTION

The rear suspension consists of leaf springs, axle housing, axle shafts and shock absorbers as shown below. The leaf springs are attached to the chassis frame through rubber bushes located at their both ends as shown. The axle housing is installed on the right and left leaf springs by means of spring seats and U bolts. The two shock absorbers (right & left) are installed with their lower ends attached to the spring seats and the upper ends to the chassis frame, all through rubber bushes.

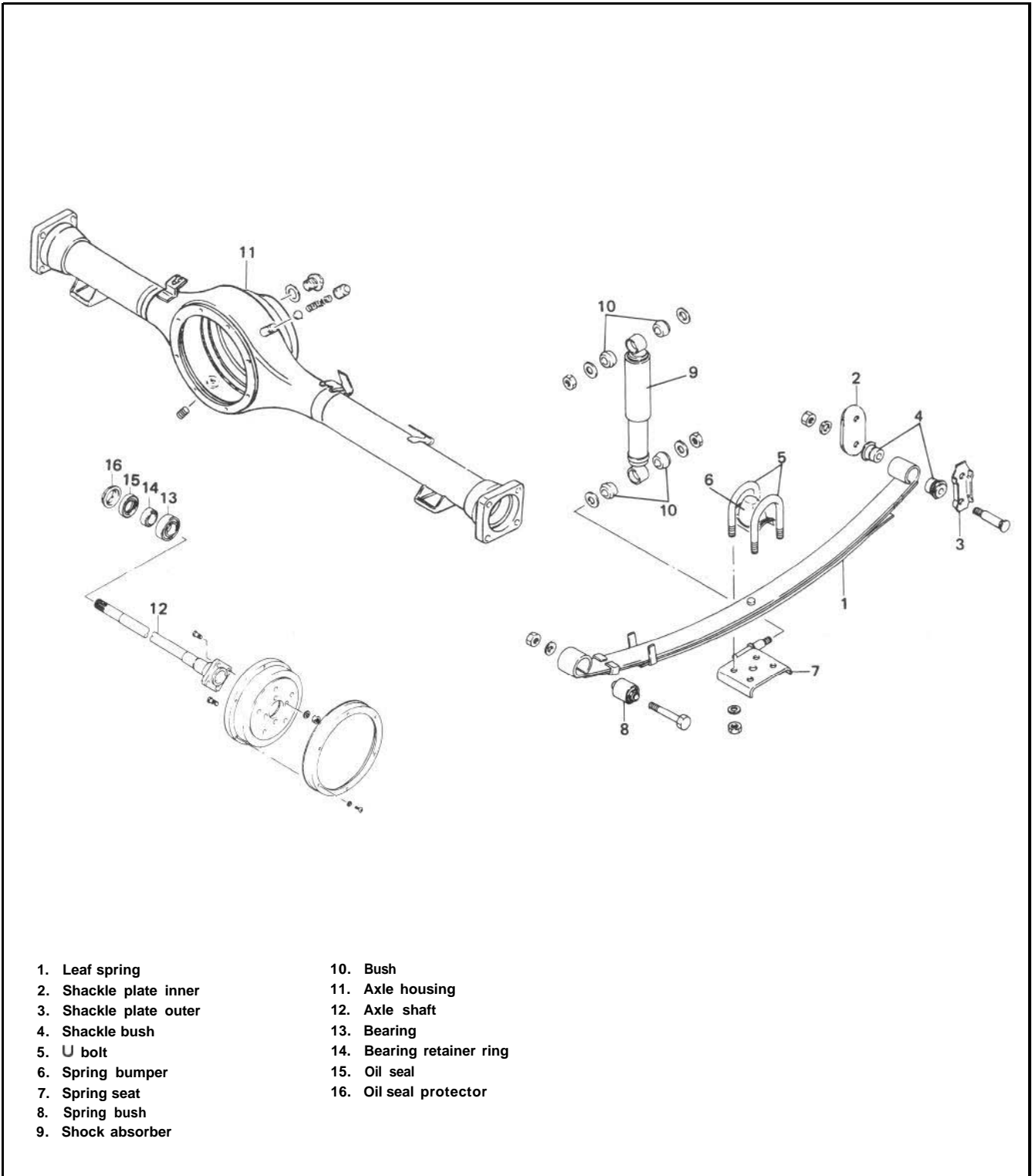


Fig 17-2-7



## REMOVAL

### Shock Absorber

The shock absorber is non-adjustable, non-refillable, and cannot be disassembled. The only service the shock absorber requires is replacement when it has lost its resistance, is damaged, or leaking oil or gas.

- 1) Hoist car.
- 2) Loosen lower and upper nuts, and remove shock absorber.

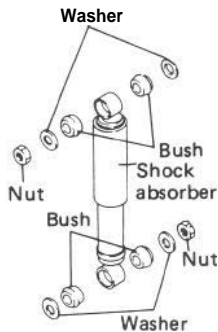


Fig. 17-2-2

### Leaf Spring

- 1) Raise car. In this operation, garage jack or hoist must not be positioned against rear suspension related parts. When garage jack is used, place safety stands under chassis to support raised body.

#### NOTE:

Don't let rear axle housing hang on brake hose or pipe. If it occurs, hose or pipe may be damaged. To prevent it, always hold rear axle housing of raised car with safety stands.

- 2) Remove rear wheel.
- 3) Remove U-bolt nuts.
- 4) Remove shackle nuts and leaf spring nut.
- 5) Pull out leaf spring bolt and remove leaf spring from shackle pin.

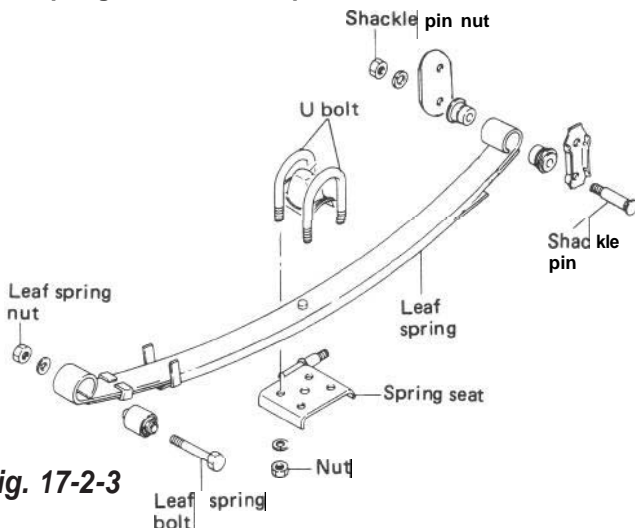
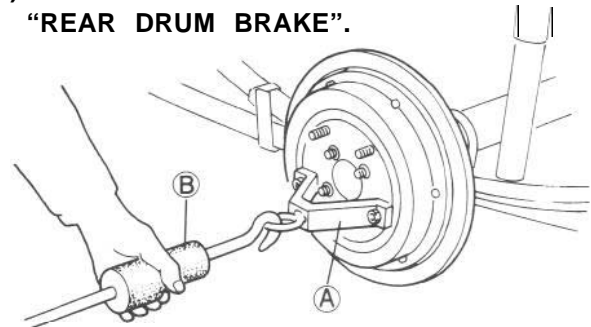


Fig. 17-2-3

### Rear Axle Shaft

- 1) Remove rear brake drum. Refer to item 19-3 "REAR DRUM BRAKE".



- (A) Special tool (Brake drum remover 09943-35511)  
 (B) Special tool (Sliding hammer 09942-15510)

Fig. 17-2-4

- 2) Drain oil from axle housing loosening drain plug.

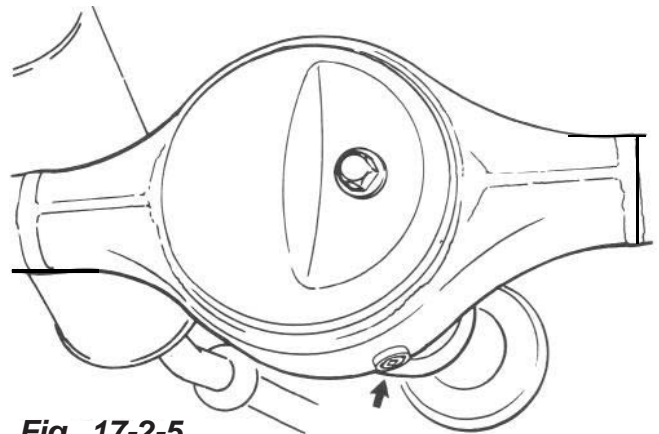


Fig. 17-2-5

- 3) Disconnect brake pipe from wheel cylinder. Have a small plug ready for use when disconnecting pipe. As pipe comes off the wheel cylinder, plug the pipe to prevent brake fluid from leaking out. And remove 4 brake backing plate securing bolts.

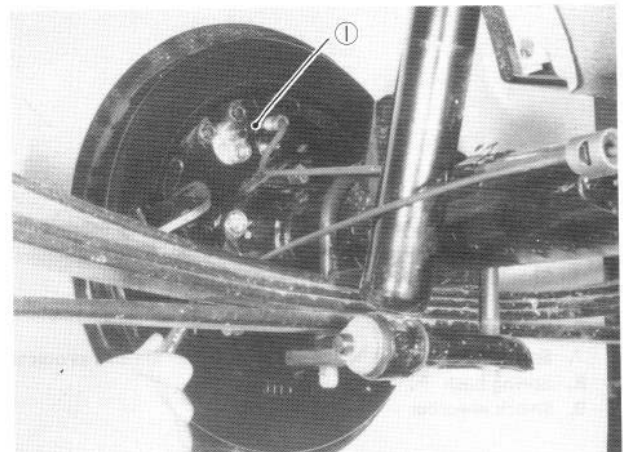
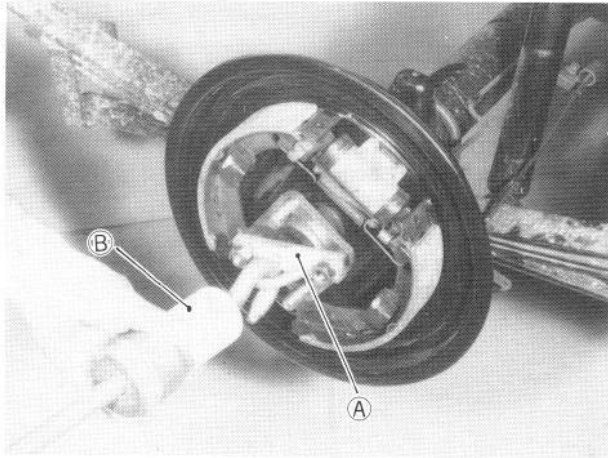


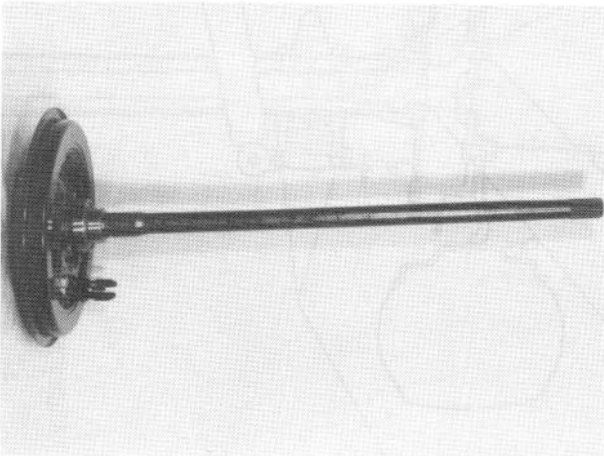
Fig. 17-2-6 1. Plug

4) Using special tools indicated below, draw out each axle shaft with brake backing plate.



**Fig. 17-2-7** (A) **Special Tool (Rear Axle Remover 09922-66010)**  
 (B) **Special Tool (Sliding Hammer 09942-15510)**

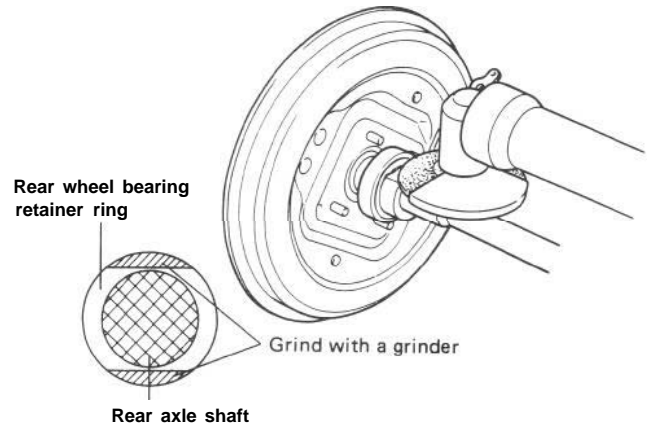
Rear axle shaft that was drawn out.



**Fig. 17-2-8**

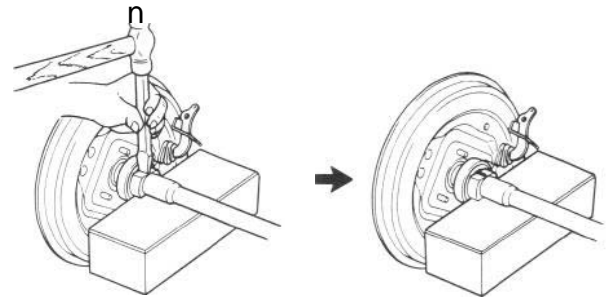
5) In order to remove the retainer ring from the shaft, grind with a grinder two parts of the bearing retainer ring as illustrated till it becomes thin.

**CAUTION:**  
 Be careful not to go so far as to grind the shaft.



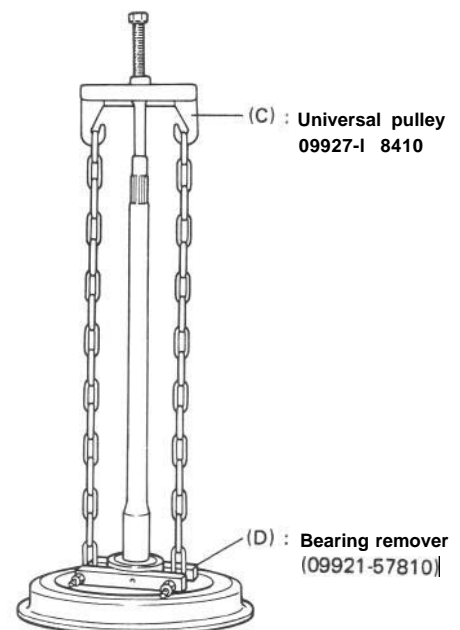
**Fig. 17-2-9**

Break with a chisel the thin ground retainer ring, and it can be removed.



**Fig. 17-2-10**

6) Using special tools (C and D), remove bearing from shaft and then remove brake back plate.



**Fig. 17-2-11**

## INSTALLATION

Reverse removal procedure observing each precaution.

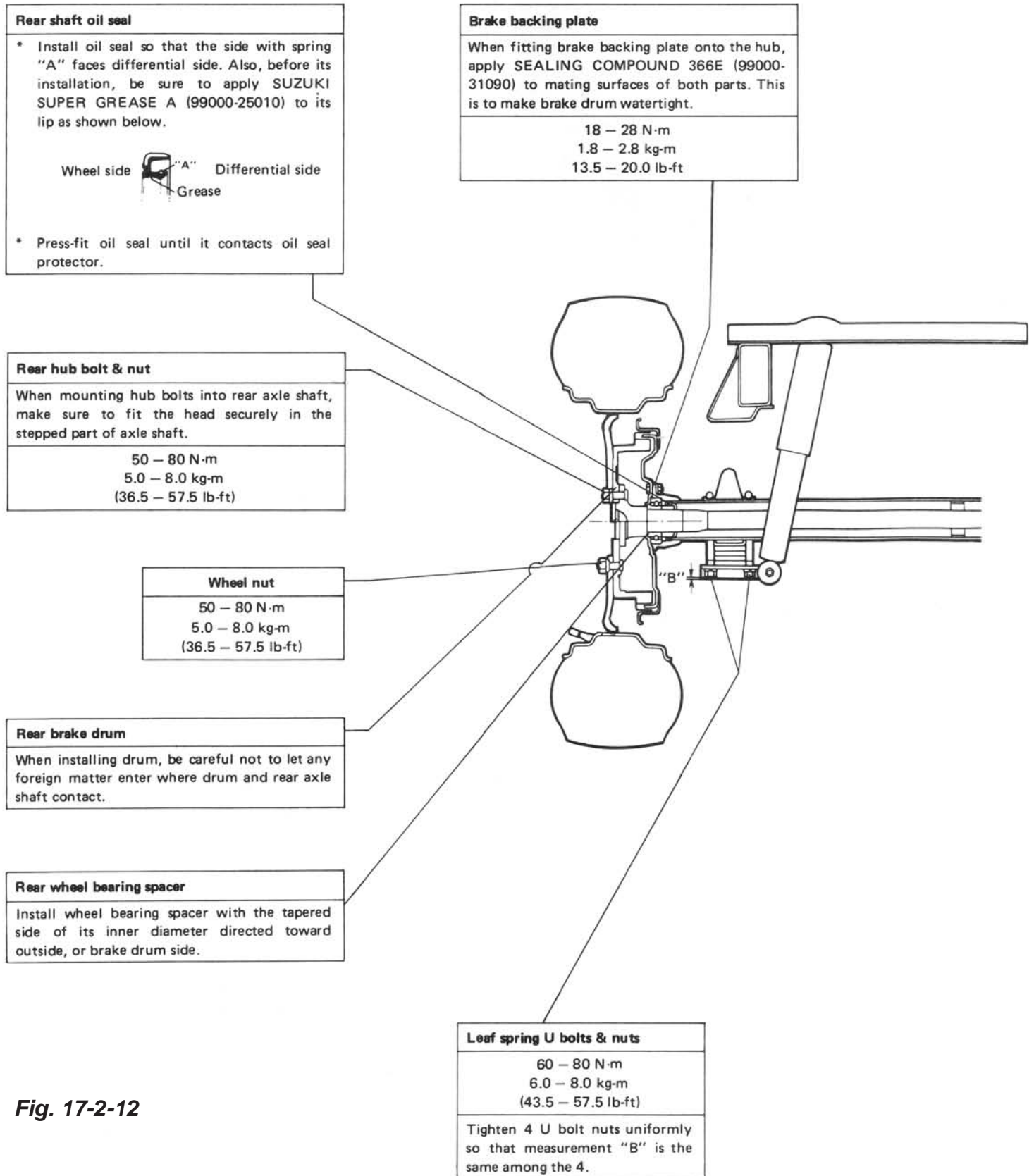
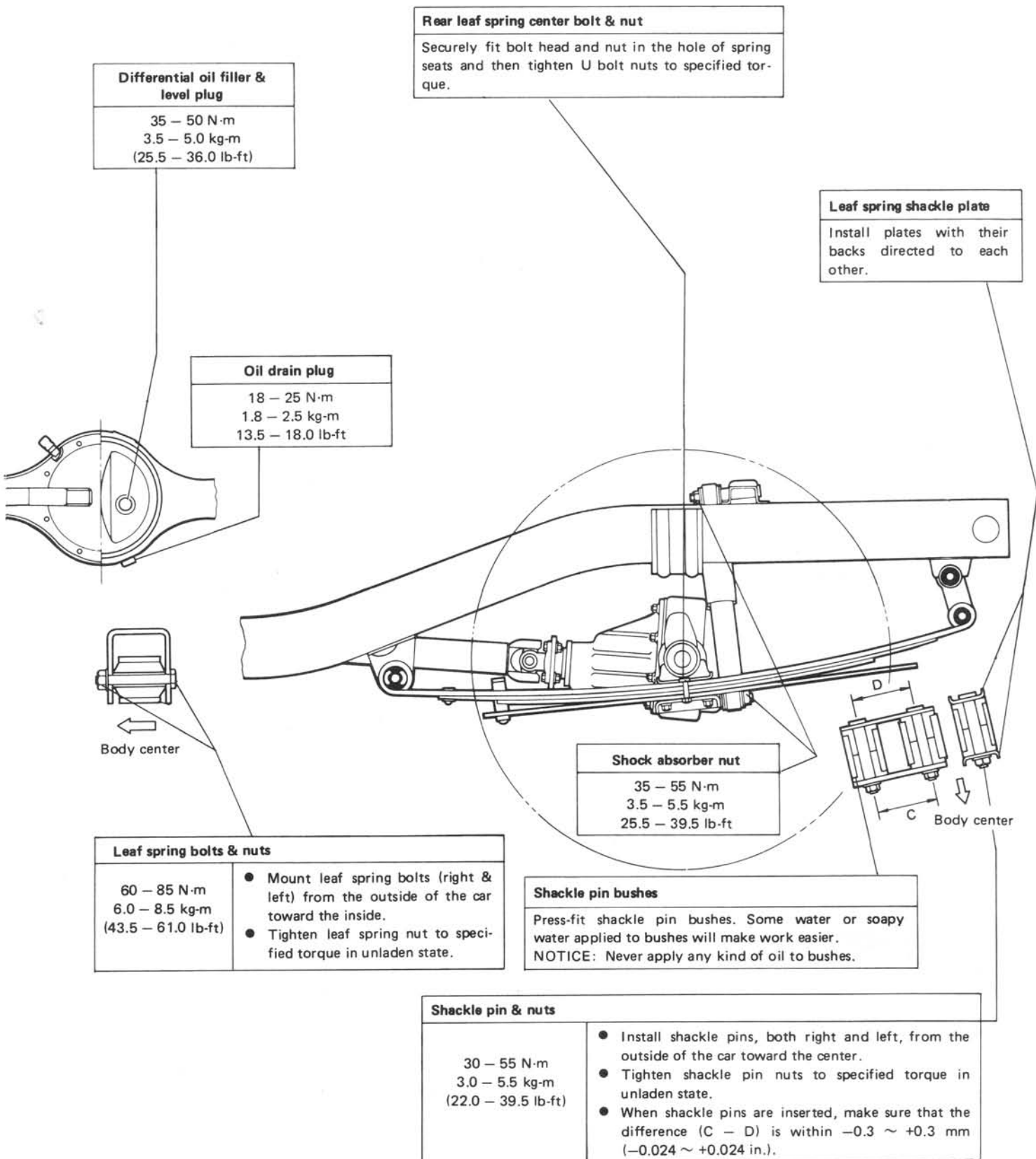


Fig. 17-2-12





**Differential oil filler & level plug**  
 35 – 50 N·m  
 3.5 – 5.0 kg-m  
 (25.5 – 36.0 lb-ft)

**Oil drain plug**  
 18 – 25 N·m  
 1.8 – 2.5 kg-m  
 13.5 – 18.0 lb-ft

**Rear leaf spring center bolt & nut**  
 Securely fit bolt head and nut in the hole of spring seats and then tighten U bolt nuts to specified torque.

**Leaf spring shackle plate**  
 Install plates with their backs directed to each other.

**Shock absorber nut**  
 35 – 55 N·m  
 3.5 – 5.5 kg-m  
 25.5 – 39.5 lb-ft

**Leaf spring bolts & nuts**

60 – 85 N·m 6.0 – 8.5 kg-m (43.5 – 61.0 lb-ft)	<ul style="list-style-type: none"> <li>● Mount leaf spring bolts (right &amp; left) from the outside of the car toward the inside.</li> <li>● Tighten leaf spring nut to specified torque in unladen state.</li> </ul>
--	--

**Shackle pin bushes**  
 Press-fit shackle pin bushes. Some water or soapy water applied to bushes will make work easier.  
 NOTICE: Never apply any kind of oil to bushes.

**Shackle pin & nuts**

30 – 55 N·m 3.0 – 5.5 kg-m (22.0 – 39.5 lb-ft)	<ul style="list-style-type: none"> <li>● Install shackle pins, both right and left, from the outside of the car toward the center.</li> <li>● Tighten shackle pin nuts to specified torque in unladen state.</li> <li>● When shackle pins are inserted, make sure that the difference (C – D) is within –0.3 ~ +0.3 mm (–0.024 ~ +0.024 in.).</li> </ul>
--	--



## 17-3. MAINTENANCE SERVICES

### Shock Absorber

- 1) Inspect for deformation or damage.
- 2) Inspect bushings for wear or damage.
- 3) Inspect for evidence of oil leakage.

Replace any defective part.

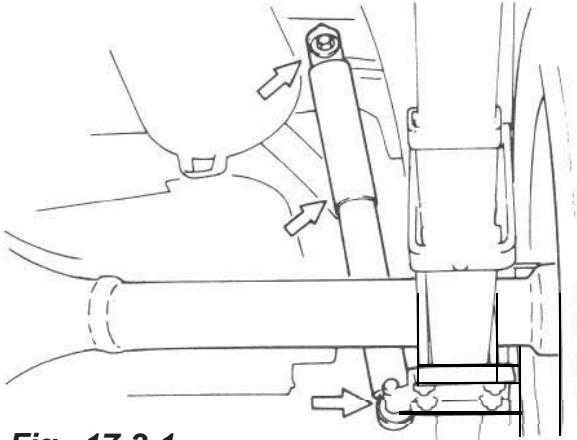


Fig. 17-3-1

#### WARNING:

When handling rear shock absorber in which high-pressure gas is sealed, make sure to observe the following precautions.

- 1) Don't disassemble it.
- 2) Don't put it into the fire.
- 3) Don't store it where it gets hot.
- 4) Before disposing it, be sure to drill a hole in it where shown by an arrow in the figure below and let gas and oil out. Lay it down sideways for this work.

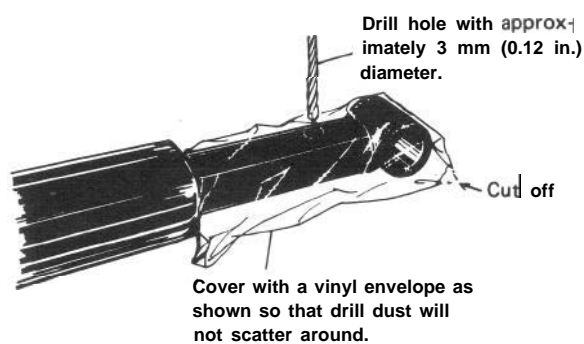


Fig. 17-3-2

### Leaf Spring and Bumper

- 1) Inspect leaf spring for crack, wear and damage.

#### NOTE:

Special attention must be paid to that part as indicated by "A" in below figure (where each end of the shorter leaf contacts).

- 2) Inspect bumper for damage.  
If found defective, **replace**.

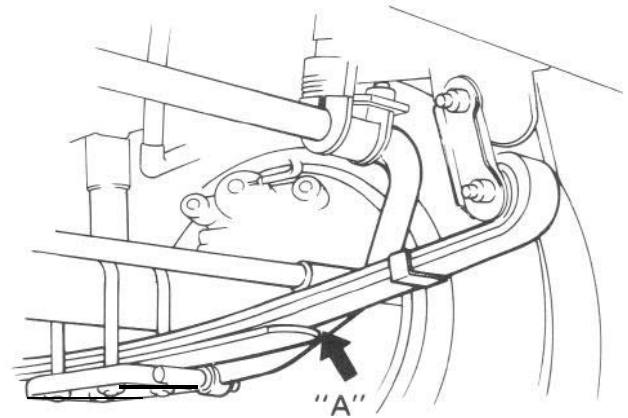


Fig. 17-3-3

### Front Wheel Bearing [ INSPECTION ]

- (1) To check wheel bearings, jack up front end. Spin wheel and check if it is spun smoothly and is free from abnormal noise. If it isn't, replace wheel bearing.

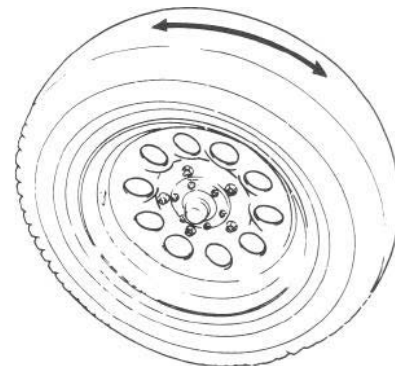


Fig. 17-3-4

- (2) Upon completion of the check in above(1), check each joint of steering system for tightness, each ball stud of the steering link as well as each kingpin for rattle. Then check bearing as described below.

- 1) Shake wheel in the direction indicated by an arrow in below figure to see if bearing rattles.

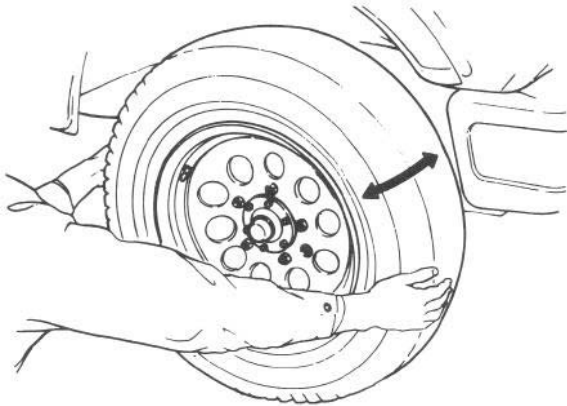


Fig. 17-3-5

- 2) Shake wheel in the direction indicated by an arrow in below figure to see if bearing rattles.



Fig. 17-3-6

- 3) If bearing rattles, check bearing preload with wheel, drive flange or free wheeling hub (if equipped) and brake caliper & holder removed as shown in below figure.

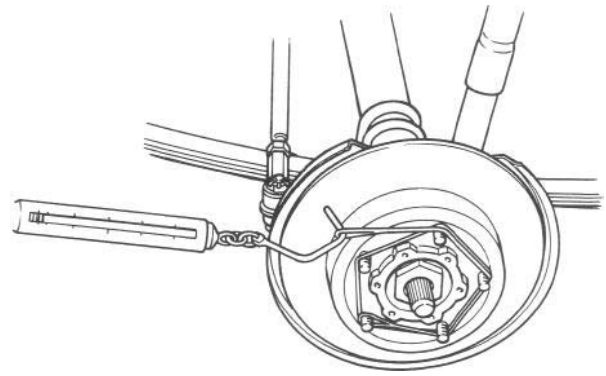


Fig. 17-3-7

Wheel bearing starting preload	1.0 – 3.0 kg (2.2 – 6.6 lb)
--------------------------------	--------------------------------

If preload is not within the above specification, adjust bearing preload according to following “adjustment”.

[Adjustment]

- (1) After removing wheel bearing lock nut and lock washer, tighten bearing nut ① to the torque of 80 N·m (8.0 kg-m, 57.5 lb-ft) while spinning hub by hand. Next, loosen the nut until the torque becomes 0 N·m (0 kg-m, 0 lb-ft) and then tighten it again to tightening torque specified below.

In this way, an appropriate bearing preload is obtained.

Wheel bearing nut ① tightening torque	10.0 – 15.0 N·m 1.0 – 1.5 kg-m (7.5 – 10.5 lb-ft)
---------------------------------------	---

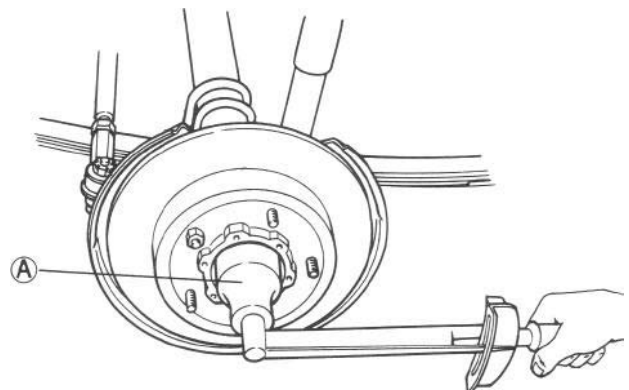
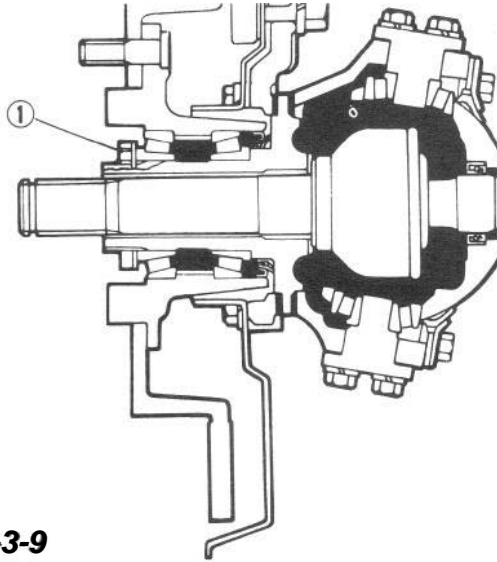


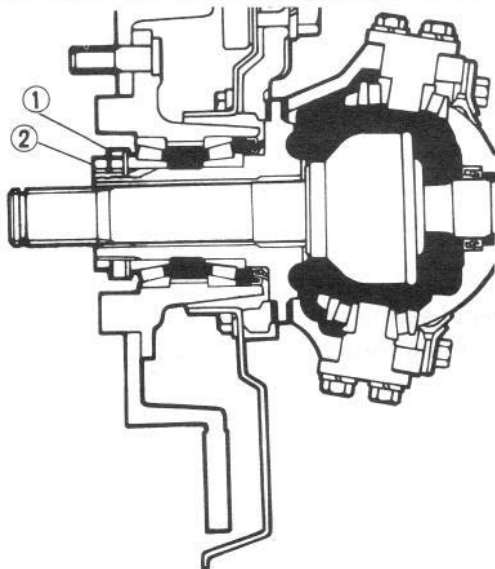
Fig. 17-3-8 (A) Special tool (Front Wheel Bearing nut socket wrench 09941-58010 )



**Fig. 17-3-9**

- (2) Be sure to insert lock washer after adjustment and tighten lock nut ② to specified torque. Then bend a part of lock washer toward bearing nut (body side) and another part toward lock nut (outside) so that these 2 nuts are locked.

Wheel bearing lock nut	<b>60</b> – 90 N·m
② tightening torque	<b>6.0</b> – 9.0 kg·m (43.5 – 65.0 lb·ft)



**Fig. 17-3-10** ① Wheel Bearing Nut  
② Wheel Bearing Lock Nut

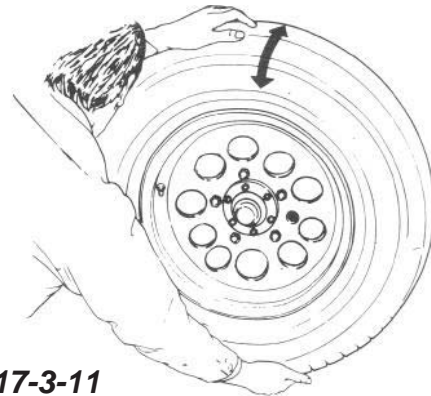
- (3) Recheck that bearing starting preload is within specification.  
 (4) Upon completion of adjustment, be sure to install axle shaft drive flange or free wheeling hub (if equipped), circlip, disc brake caliper & holder and wheel.

Refer to “INSTALLATION” in this section.

### King Pin

[ Inspection and adjustment ]

Where tapered roller bearings holding 2 kingpins at each front wheel are in good and properly preloaded (tightened) condition, there will be no appreciable rattle of wheel. To check kingpins and their tapered roller bearings, jack up the front end and shake wheel to feel any rattle, as shown in figure. If rattle is felt, eliminate it by properly decreasing the shim thickness. The shim is located between flanged part of kingpin and knuckle.

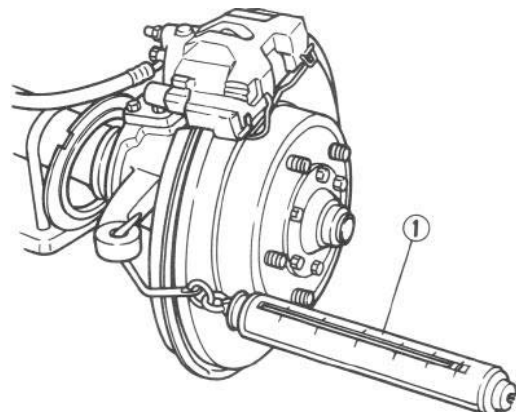


**Fig. 17-3-11**

The above-mentioned method of making a shim adjustment demands a high degree of skill on the part of the serviceman. The alternative method is to adjust shim thickness by referring to the torque resistance which knuckle arm offers when pulled in the condition shown in figure. For this method, the reference torque value is established as indicated below, and you are to increase or decrease shim thickness to produce this torque value,

#### NOTE:

After removing wheel and steering knuckle oil seal and disconnecting tie rod end, this checking and adjustment should be carried out.



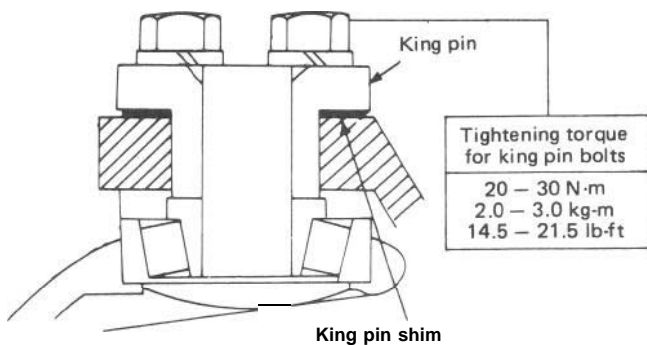
**Fig. 17-3-12** ① Spring Balance

Before giving a test pull to knuckle arm with a spring balance in the alternative method, install a large amount of shims on each kingpin to lighten preload on tapered roller bearing. Keep on reading the torque, each time decreasing shim thickness a little, and continue this process until specified torque value is obtained. (This process protects kingpins because it ensure that no excessive pull will be applied to bearings at the onset.) If the process fails to produce specified torque, that is, if desired torque resistance does not occur even when shim thickness has been reduced to zero on each kingpin, it means that bearings or kingpins are excessively worn and need replacement.

**NOTE:**

- 1 Read spring balance indication when knuckle arm begins to turn. In other words, you are to read “starting torque.”
- 1 When checking knuckle arm starting torque, be sure to have axle hub oil seal removed and tighten king pin bolts to specified torque.

Knuckle arm starting torque (force)	1.0 – 1.8 kg (2.20 – 3.96 lb) without oil seal
Available sizes of shim for kingpins	0.1, 0.5 mm (0.004, 0.02 in.)



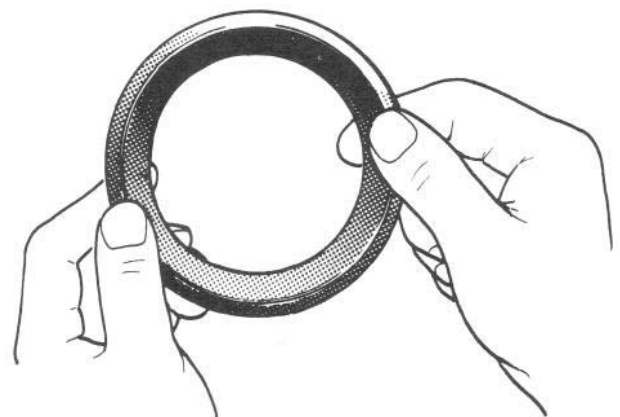
**Fig. 17-3-13**

Upon completion of this check and/or adjustment, be sure to connect tie rod end to steering knuckle and install oil seal retainer, oil seal, felt packing oil seal cover and wheel. Refer to “INSTALLATION” in this section.

**Steering Knuckle Oil Seal**

The oil seal used at the spherical sliding joint between knuckle and inner case accomplishes additional purposes of keeping out road dust and of acting as the damper for steering hand wheel. As wear of this seal advances, its damping effect decreases and thus makes front wheel develop a tendency to “shimmy” not only that road dust begins to creep into sliding clearance to promote wear of spherical sliding surfaces.

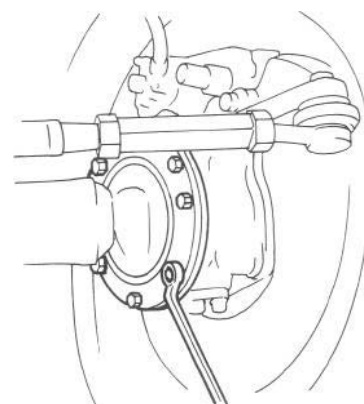
The oil seal is an expendable item, and must be replaced at regular intervals.



**Fig. 17-3-14**

[How to replace oil seal]

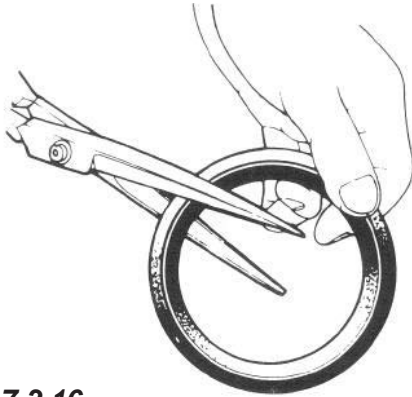
- 1) Remove 8 bolts securing joint seat, and displace oil seal cover and felt packing inward.



**Fig. 17-3-15**



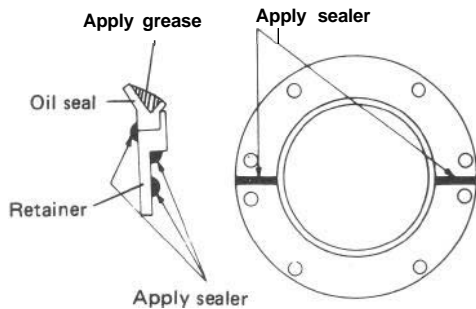
- 2) Cut oil seal in place with scissors or a knife, and take it off.
- 3) Cut replacement oil seal at one place with scissors or a knife as shown in below figure.
- 4) Install the seal in oil seal retainer, bringing the cut portion to top side and locating it about 30 degrees off the matching face of oil seal retainer.



**Fig. 17-3-16**

- 5) Apply grease to inside of oil seal. Apply sealing compound to mating face all around: this is for preventing entry of water.

<ul style="list-style-type: none"> <li>. SEALING COMPOUND "CEMEDINE" 366E (99000-31090)</li> <li>. SUZUKI SUPER GREASE H 99000-25120).</li> </ul>
---



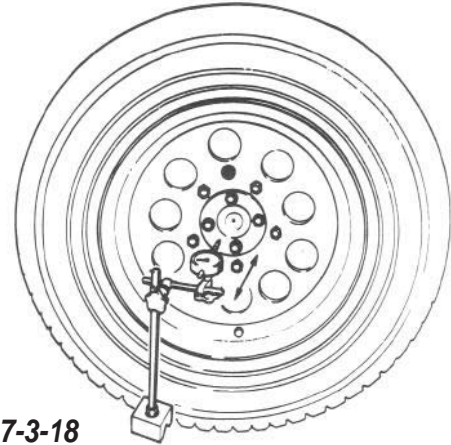
**Fig. 17-3-17**

- 6) Tighten joint seat securing bolts to specified torque.

**Rear Wheel Bearing**

- 1) Check wheel bearings for wear. When measuring thrust play, apply a dial gauge to drum center.

Thrust play Limit	Rear	0.8 mm (0.03 in.)
-------------------	------	-------------------



**Fig. 17-3-18**

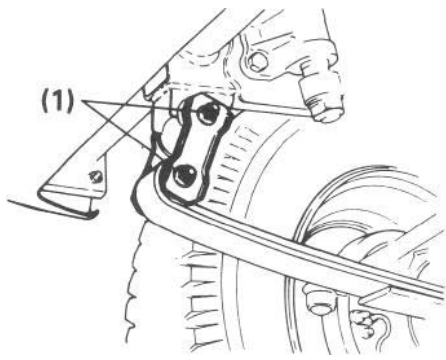
When measurement exceeds limit, replace bearing.

- 2) By rotating wheel actually, check wheel bearing for noise and smooth rotation. If it is defective, replace bearing.

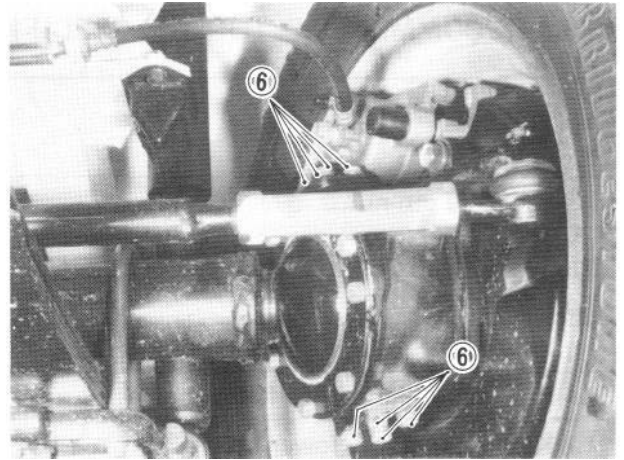
**Bolts and Nuts**

Check following bolts and nuts for tightness and retighten them to specified torque as necessary.

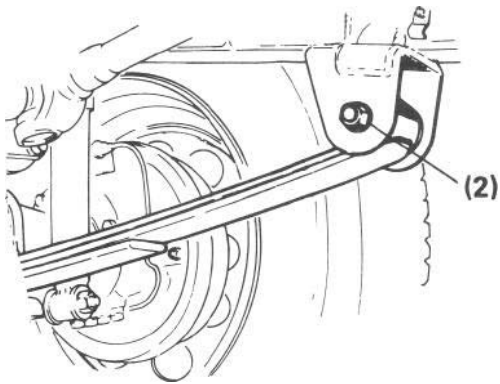
Fastening parts	Tightening torque
① Shackle pin nut	Refer to "RECOMMENDED TORQUE SPECIFICATIONS" in this section
② Leaf spring nut	
③ Leaf spring U bolt nut	
④ Wheel nut	
⑤ Front axle shaft drive flange bolt	
⑥ Kingpin upper & lower bolt	
⑦ Rear hub nut	



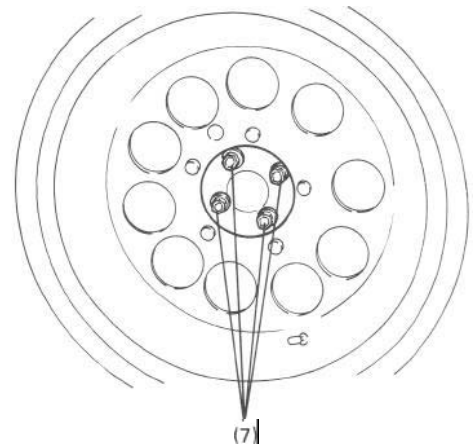
**Fig. 17-3-19**



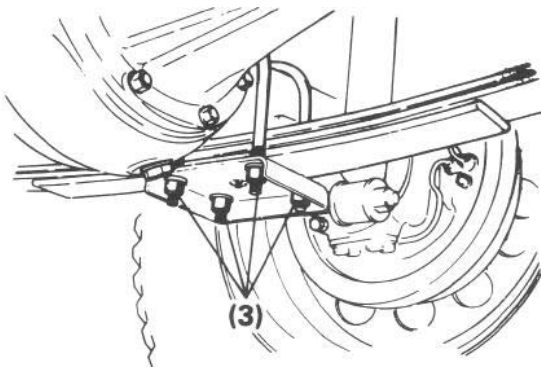
**Fig. 17-3-23**



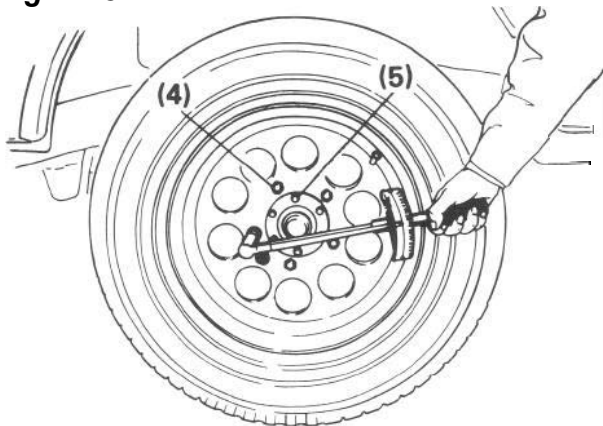
**Fig. 17-3-20**



**Fig. 17-3-24**



**Fig. 17-3-21**



**Fig. 17-3-22**

#### 17-4. RECOMMENDED TORQUE SPECIFICATIONS

Fastening parts	Tightening torque		
	N·m	kg·m	lb·ft
Schackle pin nut	30 – 55	3.0 – 5.5	22.0 – 39.5
Leaf spring nut	60 – 85	6.0 – 8.5	43.5 – 61.0
Leaf spring U bolt nut	60 – 80	6.0 – 8.0	43.5 – 57.5
Wheel nut	50 – 80	5.0 – 8.0	36.5 – 57.5
Front axle shaft drive flange bolt	20 – 30	2.0 – 3.0	14.5 – 21.5
Kingpin upper & lower bolts	20 – 30	2.0 – 3.0	14.5 – 21.5
Joint seal bolt	8 – 12	0.8 – 1.2	6.0 – 8.5
Front & rear shock absorber lower nut	35 – 55	3.5 – 5.5	22.5 – 39.5
Front shock absorber upper lock nut	22 – 35	2.2 – 3.5	16.0 – 25.0
Front leaf spring bumper bolt	18 – 28	1.8 – 2.8	13.5 – 20.0
Stabilizer bolt	70 – 90	7.0 – 9.0	51.0 – 65.0
Stabilizer nut	22 – 35	2.2 – 3.5	16.0 – 25.0
Stabilizer mount bracket bolt	18 – 28	1.8 – 2.8	13.5 – 20.0
Front wheel bearing nut	10 – 15	1.0 – 1.5	7.5 – 10.5
Front wheel bearing lock nut	60 – 90	6.0 – 9.0	43.5 – 65.0
Differential oil drain plug	18 – 25	1.8 – 2.5	13.5 – 18.0
Differential oil filler & level plug	35 – 50	3.5 – 5.0	25.5 – 36.0
Rear hub nut	50 – 80	5.0 – 8.0	36.5 – 57.5

## 17-5. FRONT FREE WHEELING HUB (OPTIONAL)

### General Description

This section describes operation, installation and maintenance of free wheeling hub. Be sure to refer to this section carefully for proper service.

### Operation

A free wheeling hub should be fitted onto each of the right and left front wheel hubs. The free wheeling hub has a knob and two embossed marks, "FREE" and "LOCK". When the knob is set to the "FREE" position, the axle shaft and wheel are disconnected and the revolution of the front wheels becomes free. When it is set to the "LOCK" position, the axle shaft and wheel are connected.

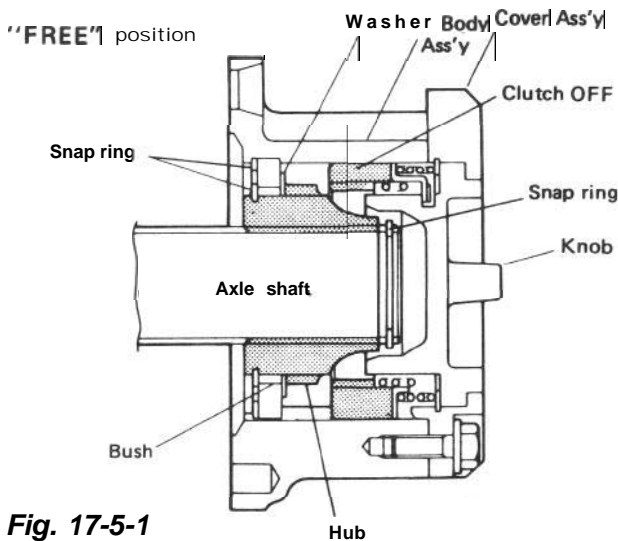


Fig. 17-5-1

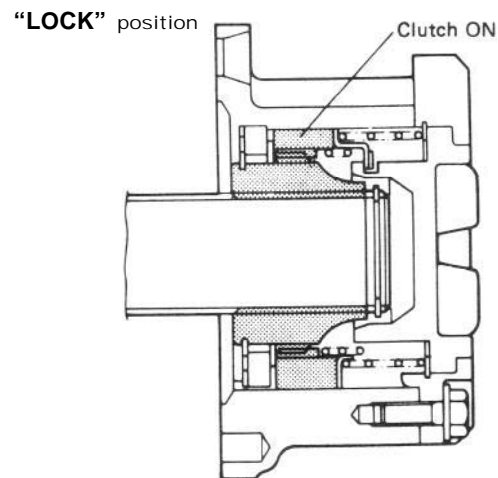


Fig. 17-5-2

For their usage, refer to Owner's Manual supplied with the car.

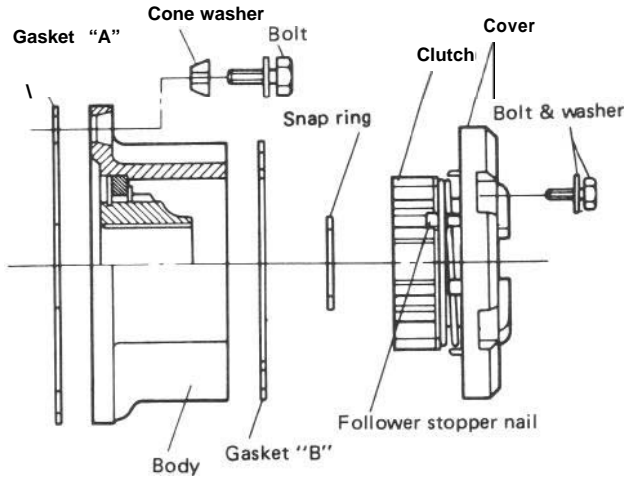
### CAUTION :

Both of the right and left wheeling hub knobs must be set to the same position (either FREE or LOCK). Don't set one to 'FREE" and the other to "LOCK" positions.



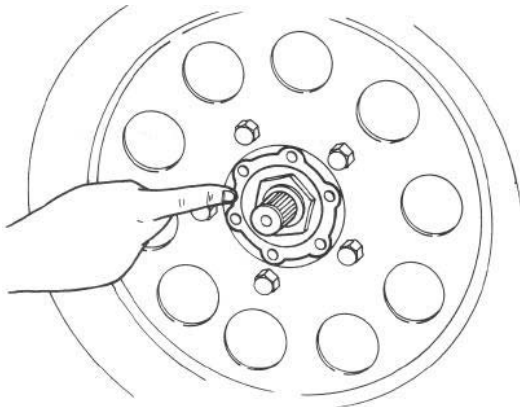
**Installation Instruction**

After removing front axle shaft drive flange, install parts (shown in below figure) in accordance with the following procedure.



**Fig. 17-5-3**

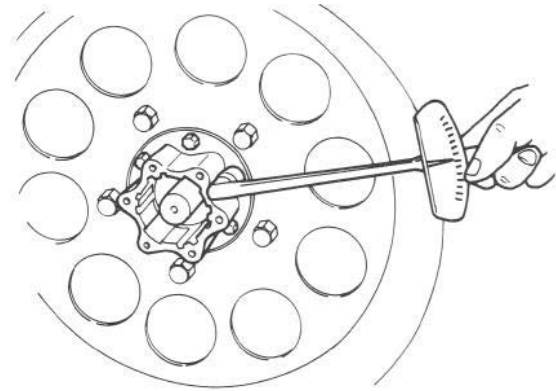
- 1) After aligning "▽" mark on the knob of free wheeling hub cover with "FREE" position, separate free wheeling cover ass'y from body ass'y .
- 2) To facilitate installation, apply sealing compound 366E (99000-31090) thin.



**Fig. 17-5-4**

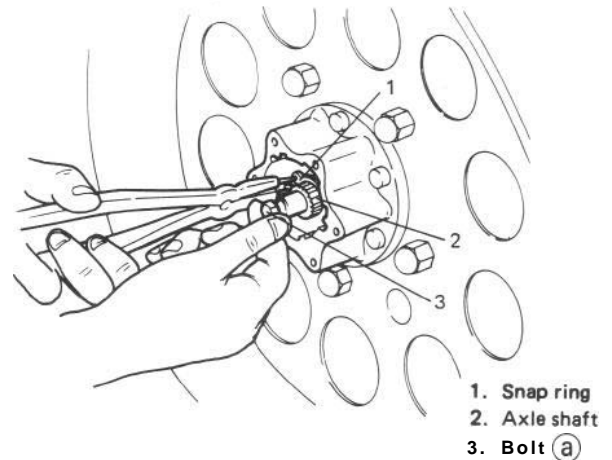
- 3) Install gasket "A" and free wheeling hub body ass'y on front wheel hub.

Tightening torque	N.m	kg-m	lb-ft
	20 - 30	2.0 - 3.0	14.5 - 21.5



**Fig. 17-5-5**

- 4) Put bolt (a) into front axle shaft and pull out the shaft and fit snap ring in the groove of axle shaft.  
Remove bolt (a) from axle shaft.



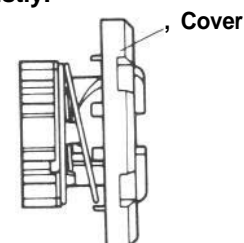
**Fig. 17-5-6**

- 5) Install cover ass'y to body ass'y so that follower stopper nail is fitted into groove of body ass'y.

**NOTE:**

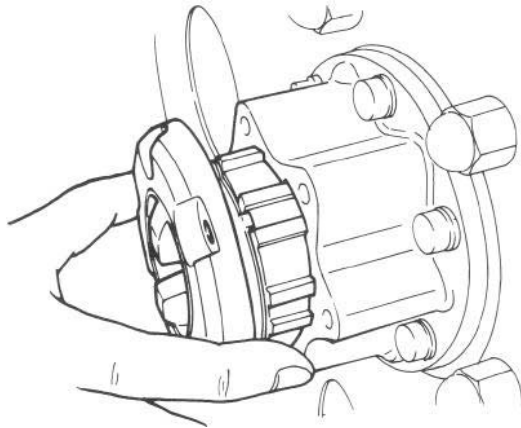
Before installing cover ass'y, make sure of following points.

- 1 "▽" mark on knob is at "FREE" position.
- 1 Clutch is lifted to the cover side, if not (shown in below figure) it may cause malfunction.
- 1 Gasket is set justly.



**Fig. 17-5-7**

There are two follower stopper nails and two grooves which can be fitted freely.

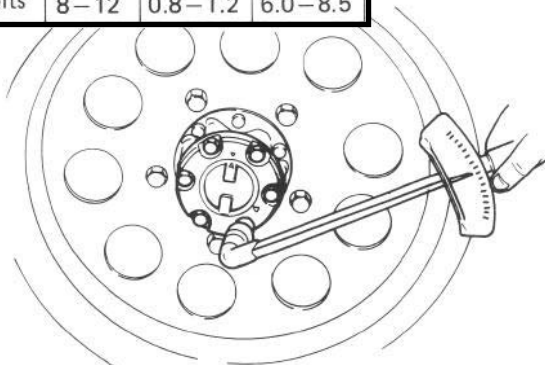


**Fig. 17-5-8**

6) Fix cover ass'y to body ass'y with cover bolts.

Tightening torque

Cover bolts	N·m	kg-m	lb-ft
	8-12	0.8-1.2	6.0-8.5



**Fig. 17-5-9**

7) To check free wheeling hub operation, jack up the front end, move the knob of free wheeling hub between "FREE" and "LOCK" positions and check for smoothness. Also check if wheel operates correctly with the knob at "FREE" and "LOCK" positions and by rotating wheel by hand.

**Maintenance Service**

The car equipped with free wheeling hubs are subject to the following periodical checks.

To check free wheeling hubs operation, jack up the front end, move the knob of free wheeling hub between "FREE" and "LOCK" positions

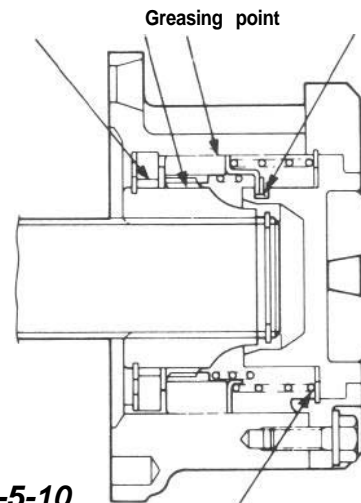
and check for smoothness. Also check if wheel operates correctly with the knob at "FREE" and "LOCK" positions and by rotating wheel by hand.

Should the check result be unsatisfactory, remove free wheeling hub cover and grease each sliding surface with SUZUKI SUPER GREASE A (99000-25010) or multipurpose grease after cleaning each sliding part.

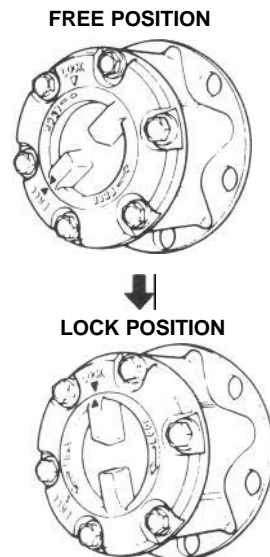
If faulty operation is still noted even after greasing, correct defective part or replace it with a new one.

**CAUTION:**  
Hubs should not be packed with grease.

For installation, refer to "Installation Instruction" in this section.



**Fig. 17-5-10**



**Fig. 17-5-11**

# SECTION 18

## STEERING SYSTEM

### CONTENTS

18-1. GENERAL DESCRIPTION .....	18-4
18-2. SPECIFICATIONS AND DATA .....	18-4
18-3. STEERING GEAR BOX CONSTRUCTION AND OPERATION ...	18-5
18-4. REMOVAL .....	18-6
18-5. INSPECTION OF COMPONENTS .....	18-9
18-6. CHECKING STEERING COLUMN FOR ACCIDENT DAMAGE.	18-11
18-7. IMPORTANT STEPS IN REINSTALLATION .....	18-12
18-8. WHEEL ALIGNMENT .....	18-16
18-9. MAINTENANCE SERVICES .....	18-18
18-10. RECOMMENDED TORQUE SPECIFICATIONS .....	18-22

**NOTE:**

All steering system fasteners are important parts in that they could affect the performance of vital parts and systems, and/or could result in major repair expense. They must be replaced with one of the same part number or with an equivalent part if replacement becomes necessary. Do not use a replacement part of lesser quality or substitute design. Torque values must be used as specified during reassembly to assure proper retention of this part.

## 18-1. GENERAL DESCRIPTION

The rotary motion of the steering handwheel is carried to the steering shaft upper, steering shaft lower, steering gear box and pitman arm. Then as the pitman arm moves, the drag rod is caused to move linearly, actuating the tie rod to turn the wheels, right and left, through their knuckle arms. The turning force exerted by the tie rod experiences a damping action due to the presence of the oil seal at the sphere-like joint between the knuckle case and the inner case (integral with the dead axle sleeve). Another damping action is available, which will be mentioned below.

The steering system formed by the components named above is designed for easy steering, high durability and excellent steering reaction as well as reliable self-restoring action. Articulated joints in the steering lever is equipped with a damping device for ensuring the greater steering stability.

Linkage are of wear-resistant ball-and-socket type. Pitman arm is equipped with a damping device for ensuring the greater steering stability.

[Right-hand steering vehicle]

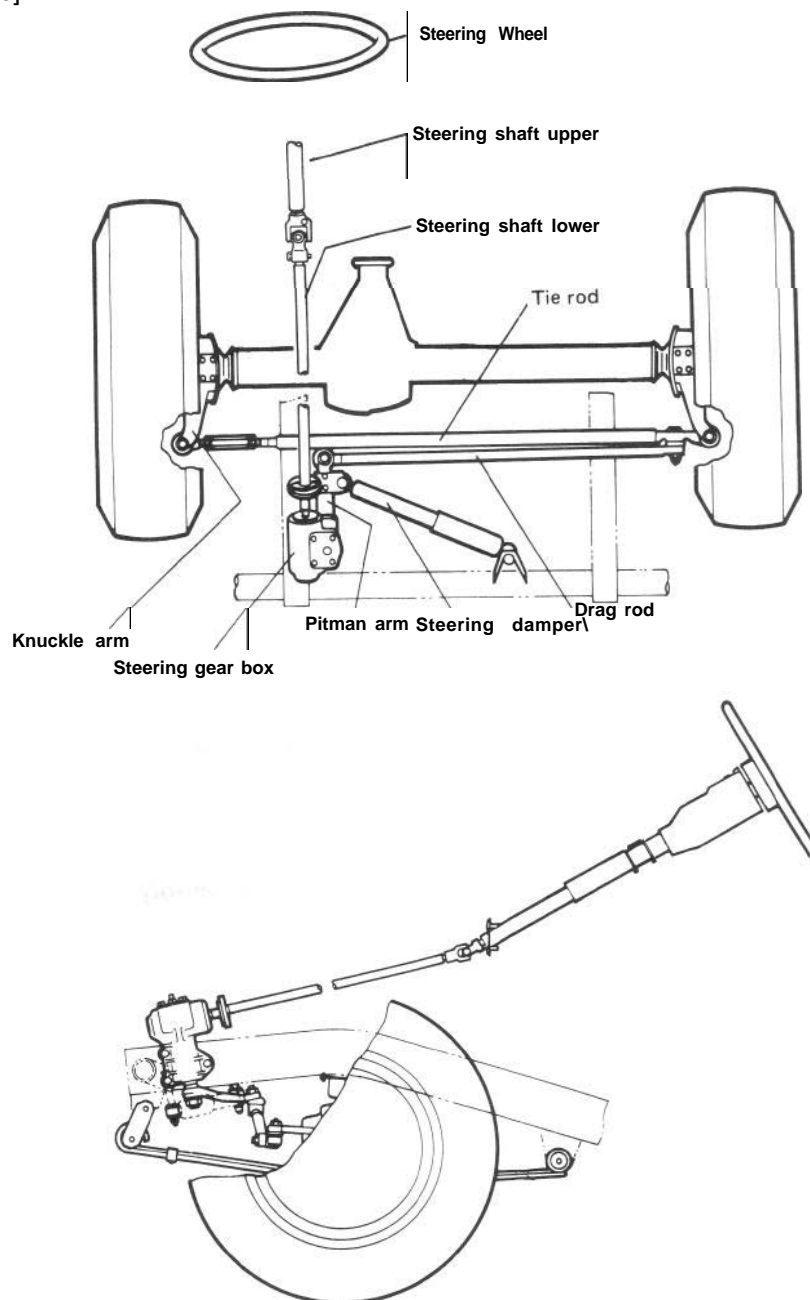


Fig. 18-1

[Left-hand steering vehicle]

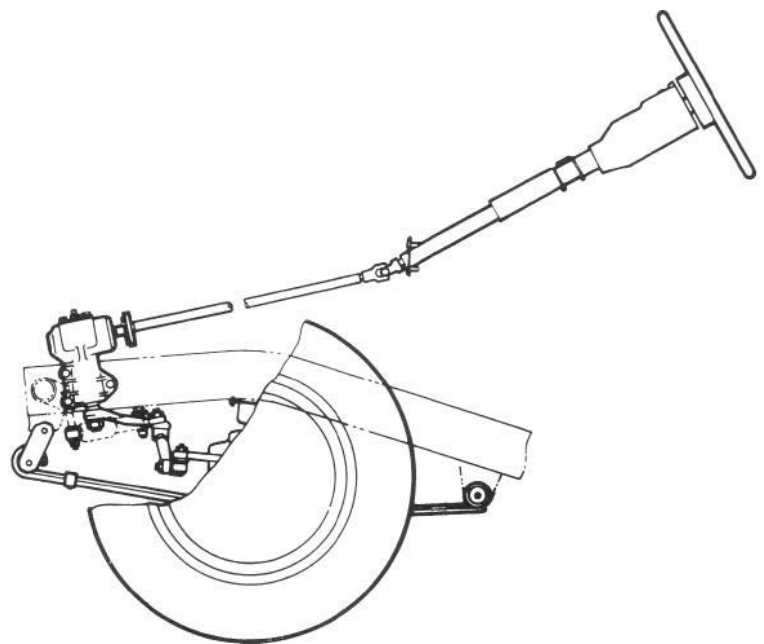
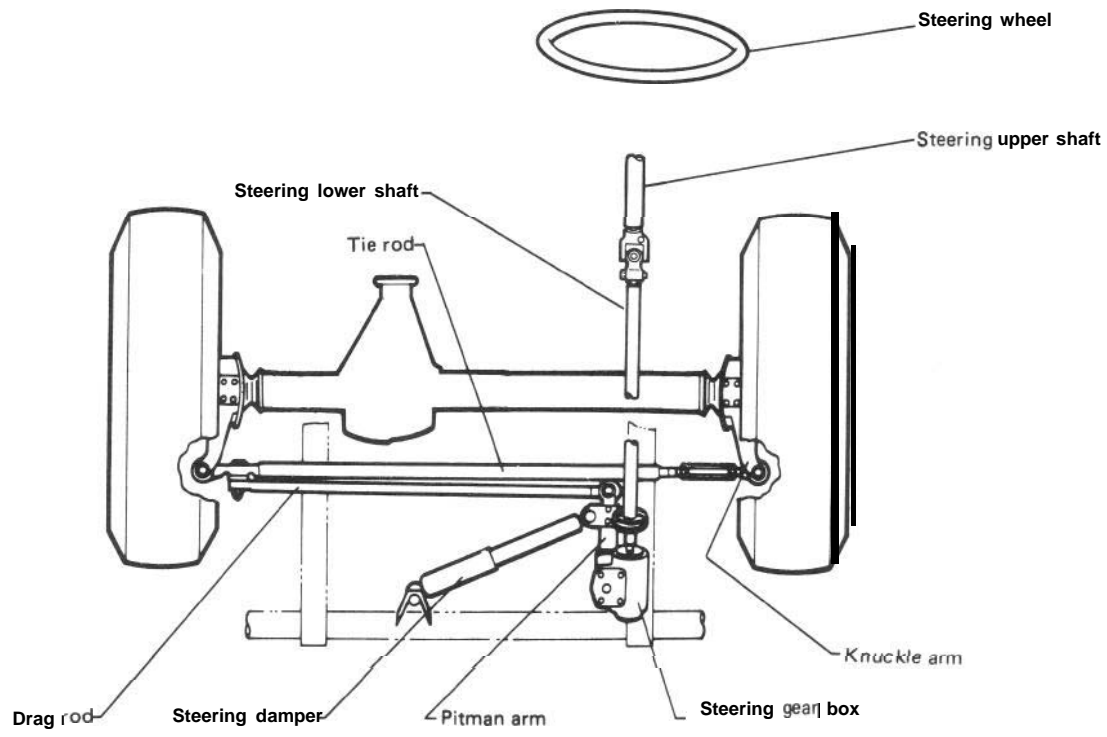


Fig. 18-1-1

## 18-2. SPECIFICATIONS AND DATA

Steering gear box		Recirculating ball-and-nut type
Gear ratio		15.6 – 18.1
Steering angle, inside		29° ± 3°
Steering angle, outside		26° ± 3°
Steering wheel diameter		400 mm (15.74 in.)
Minimum turning radius		5.1 m (16.73 ft.)
WHEEL ALIGNMENT	Toe-in	2 – 6 mm (0.079 – 0.236 in.)
	Camber	1 degree (1'') ± 45'
	Kingpin inclination	9 degree (9'') ± 2"
	Caster	3 degree 30 minutes (3' 30') ± 1"
	Side slip	0 – in 3 m/km

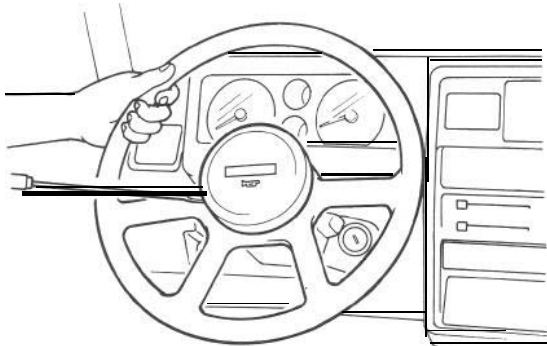
## 18-4. REMOVAL

### NOTE:

When removing the column assembly from the car, special care must be taken in handling it. Use of a steering wheel puller other than the steering wheel remover recommended in this manual or a sharp blow on the end of the steering shaft, leaning on the assembly, or dropping the assembly is prohibited. Any of such actions could shear the plastic shear pins which maintain column length especially.

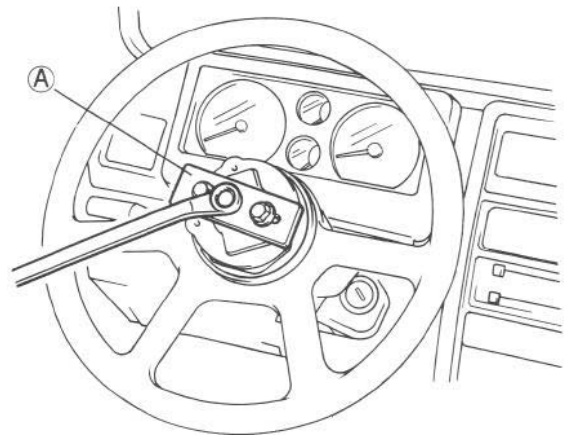
### Steering Hand Wheel

- 1) Disconnect negative battery cable.
- 2) Pull horn button to remove.



**Fig. 18-3**

- 3) After loosening steering shaft nut, remove steering wheel by using special tool.



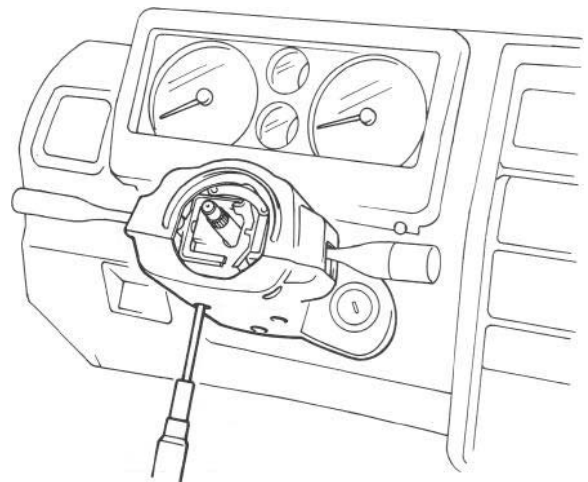
**Fig. 18-4** (A) *Special tool (Steering wheel remover 09944-36010)*

### Steering Column

- 1) After removing steering handwheel according to the foregoing step, remove steering covers (lower & upper).

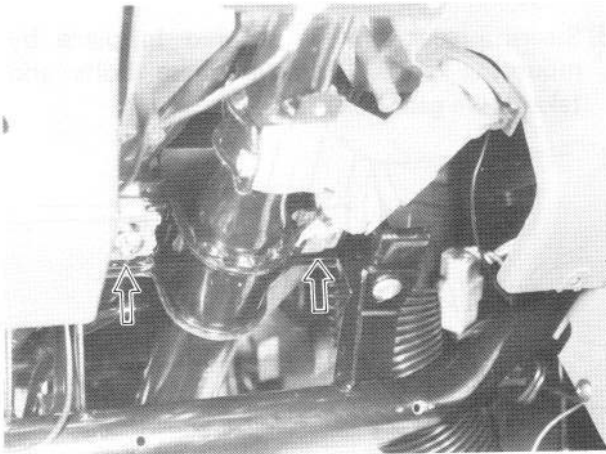
### NOTE:

After removing instrument lower panel, loosen 2 screws and 4 nuts securing steering column to remove upper cover.

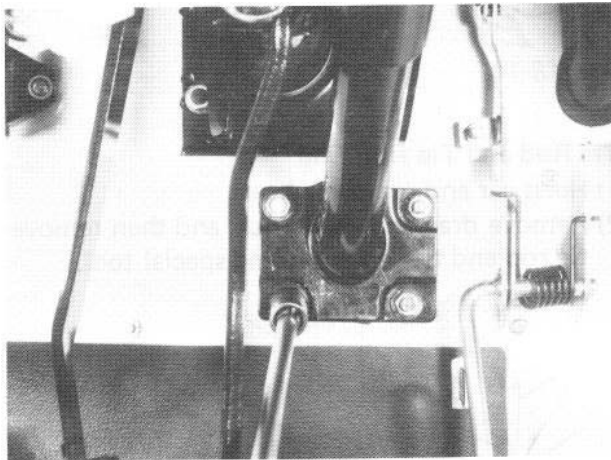


**Fig. 18-5**



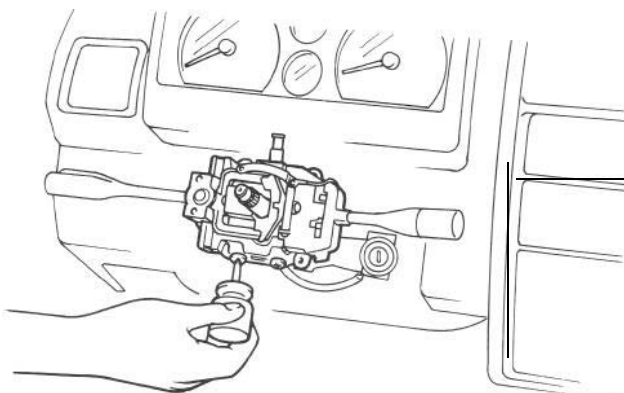


**Fig. 18-6**



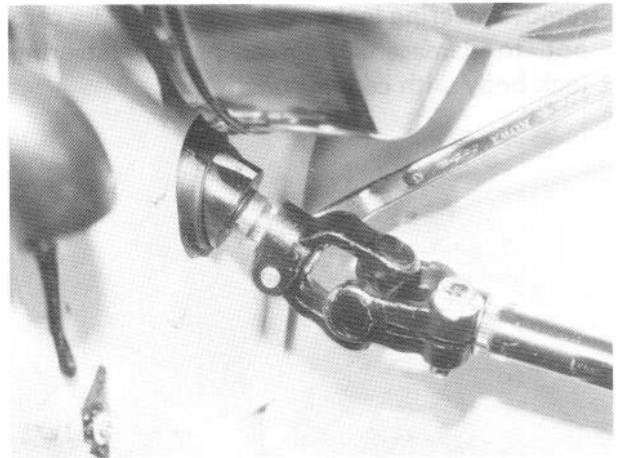
**Fig. 18-7**

- 2) Disconnect combination switch couplers and remove combination switch.



**Fig. 18-8**

- 3) Remove the bolt joining steering shafts in engine room.

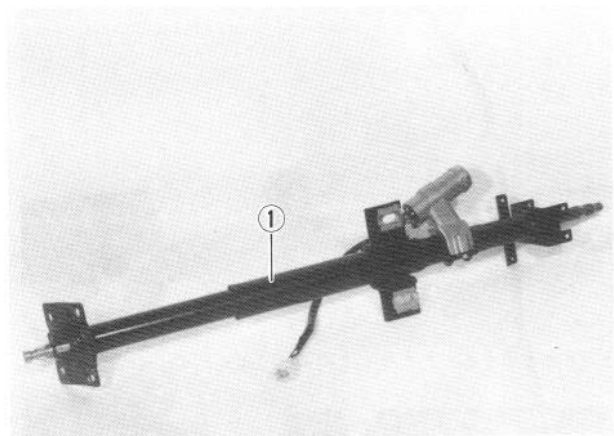


**Fig. 18-9**

- 4) Remove steering column ass'y.

NOTE:

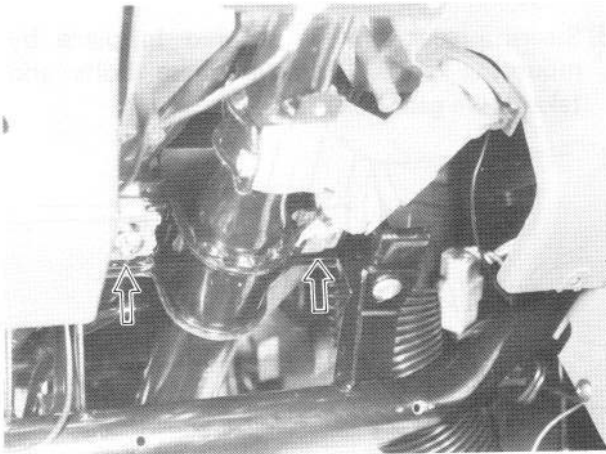
- 1 Don't separate steering column assembly into steering column and shaft. If column or shaft is defective, replace as an assembly.



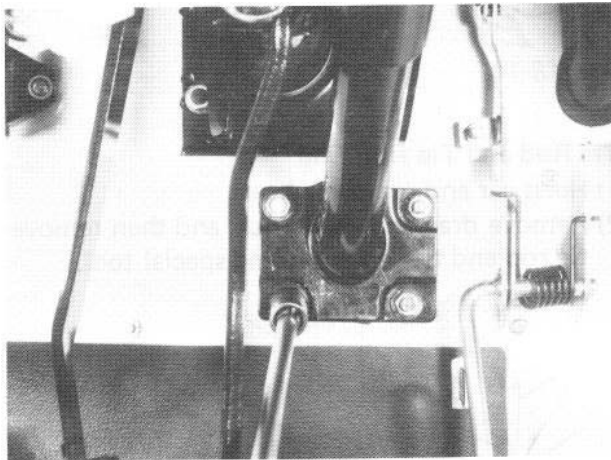
**Fig. 18-10**

1. Steering column ass'y



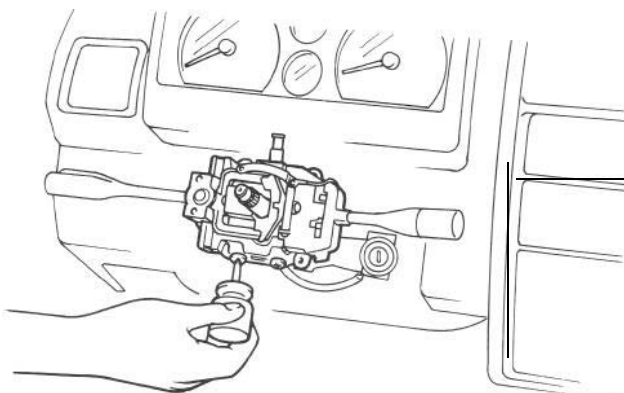


**Fig. 18-6**



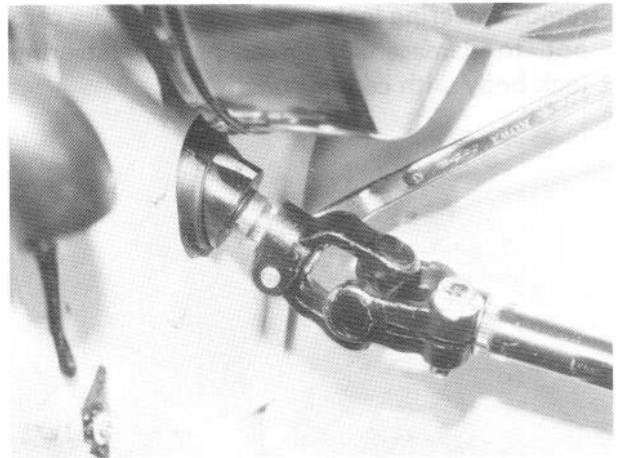
**Fig. 18-7**

- 2) Disconnect combination switch couplers and remove combination switch.



**Fig. 18-8**

- 3) Remove the bolt joining steering shafts in engine room.

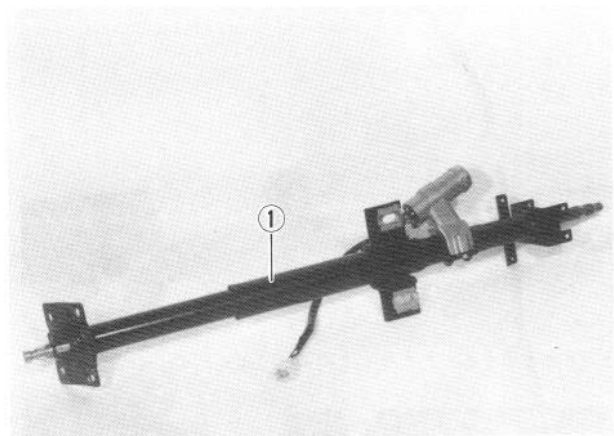


**Fig. 18-9**

- 4) Remove steering column ass'y.

NOTE:

- 1 Don't separate steering column assembly into steering column and shaft. If column or shaft is defective, replace as an assembly.

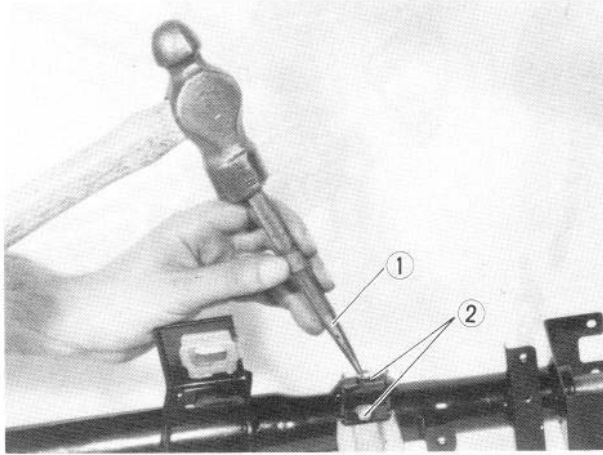


**Fig. 18-10**

1. Steering column ass'y

**Steering Lock**

- 1) After removing steering column, loosen and remove steering lock mounting bolts. Use care not to damage aluminum part of steering lock body with center punch.

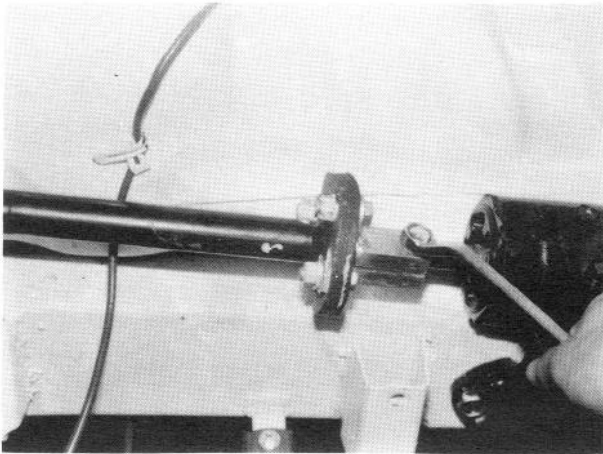


**Fig. 18-11** 1) Center punch (with sharp point)  
2. Steering lock mounting bolts

- 2) Remove steering lock assembly from steering column.

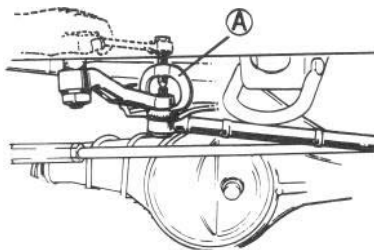
**Gear Box**

- 1) Remove joint bolt.



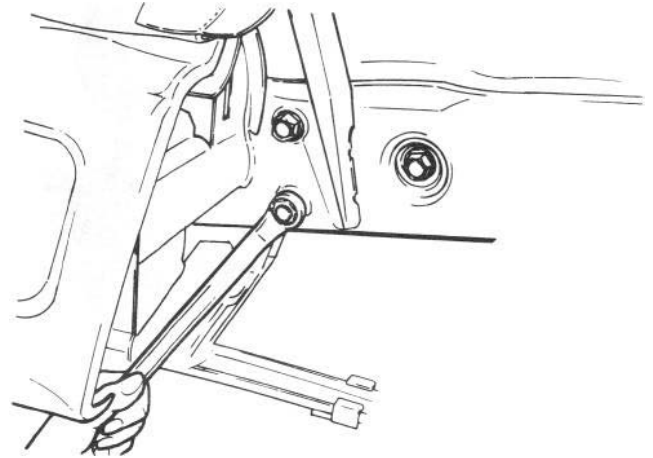
**Fig. 18-12**

- 2) Remove radiator under cover, and disconnect ball stud of drag rod using special tool and steering damper from pitman arm.



**Fig. 18-13** (A) Special tool (Tie-rod end remover 09913-65210)

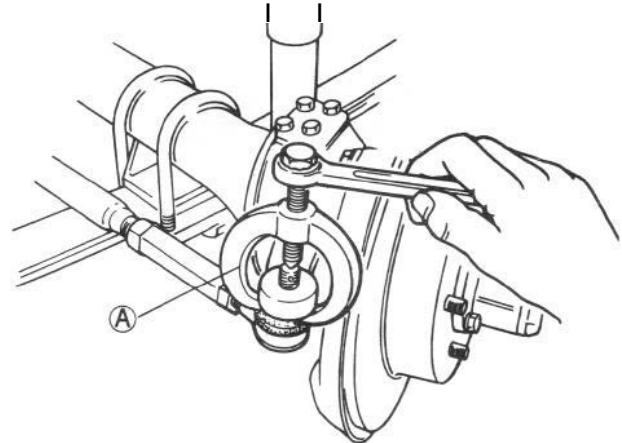
- 3) Steering gear box is secured in place by mounting bolts. Remove these bolts and take down gear box.



**Fig. 18-14**

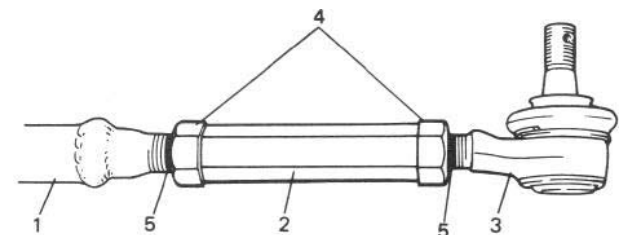
**Tie Rod and Tie Rod End**

- 1) Hoist car and remove wheels.
- 2) Remove drag rod castle nut, and then remove tie rod and tie rod end using special tool.



**Fig. 18-15** (A) Special tool (Tie-rod end remover 09913-65210)

- 3) For ease of adjustment after installation, mark tie rod and tie rod end to indicate lock nut positions. Then loosen each lock nut and separate tie rod and tie rod end.



1. Tie rod
2. Turnbuckle
3. Tie rod end
4. Locknut
5. Marking to be made

**Fig. 18-16**

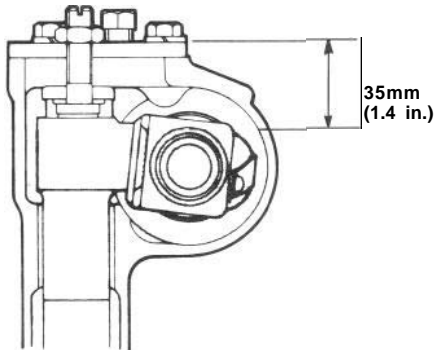
## 18-5. INSPECTION OF COMPONENTS

### Steering Gear Box

#### [Oil level]

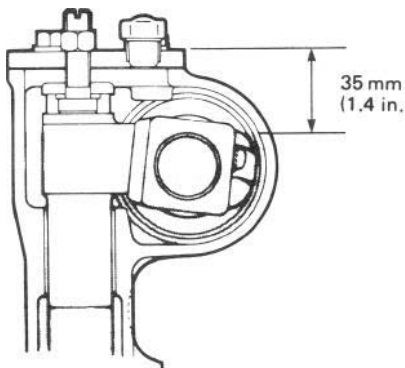
Oil surface should be up to the level as shown in below figures. If not, add prescribed gear oil, SAE 90.

Right hand steering vehicle



**Fig. 18-17**

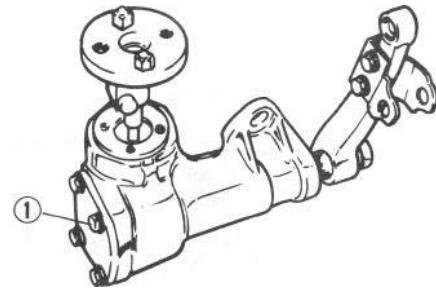
Left hand steering vehicle



**Fig. 18-18**

#### [Adjustment of worm shaft starting torque]

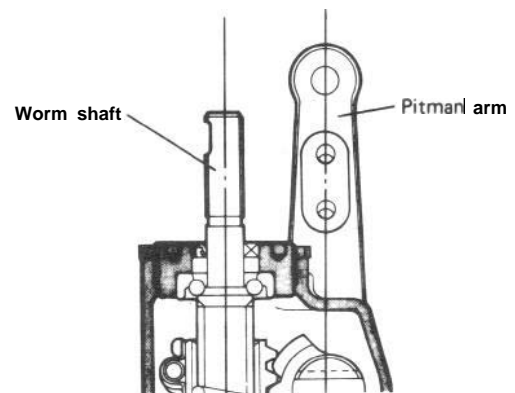
The steering gear box is provided with adjusting bolt ① which gives preload to sector shaft.



**Fig. 18-19 (1) Adjusting bolt**

Make an adjustment according to the following procedure.

- 1) Check worm shaft to ensure that it is free from thrust play.
- 2) Position pitman arm in parallel with worm shaft as shown below.  
(With pitman arm in this position, front wheel is in straightforward state.)



**Fig. 18-20**

3) Measure worm shaft starting torque from its position in the straightforward state in 2), using a spring balance and string as shown in below figure.

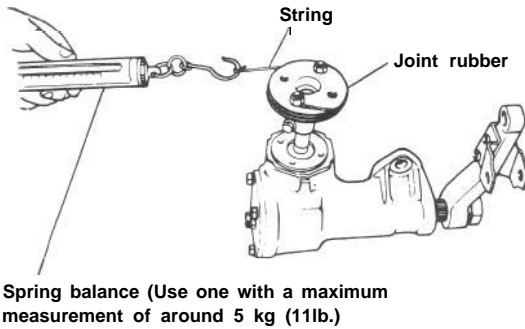


Fig. 18-21

Worm shaft (including sector shaft) starting torque (with torque wrench)	Right-hand steering vehicle 7.5 – 13.0 kg-cm (0.54 – 0.94 lb-ft)
	Left-hand steering vehicle 6.0 – 10.0 kg-cm (0.43 – 0.72 lb-ft)

Worm shaft (including sector shaft) starting torque (with spring balance)	Right-hand steering vehicle 1.97 – 3.42 kg (4.34 – 7.53 lb)
	Left-hand steering vehicle 1.58 – 2.63 kg (3.48 – 5.80 lb)

If measured torque is not within the specification, carry out adjustment with adjusting bolt ① to meet specification and check to confirm it again.

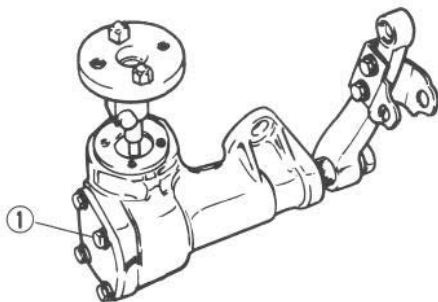


Fig. 18-22

4) If worm shaft starting torque is checked all right, another check should be carried out on worm shaft operating torque in its entire operating range (turning the worm shaft all the way to the right and left) as shown in Fig. 18-21.

Worm shaft (including sector shaft) operating torque (with torque wrench)	Right-hand steering vehicle Under 13.0 kg-cm (Under 0.94 lb-ft)
	Left-hand steering vehicle Under 12.0 kg-cm (Under 0.86 lb-ft)
Worm shaft (including sector shaft) operating torque (with spring balance)	Right-hand steering vehicle Under 3.42 kg (Under 7.53 lb)
	Left-hand steering vehicle Under 3.15 kg (Under 6.96 lb)

If measured torque does not conform to specification, readjust worm shaft starting torque in straightforward state by means of adjusting bolt ①, and then recheck worm shaft operating torque.

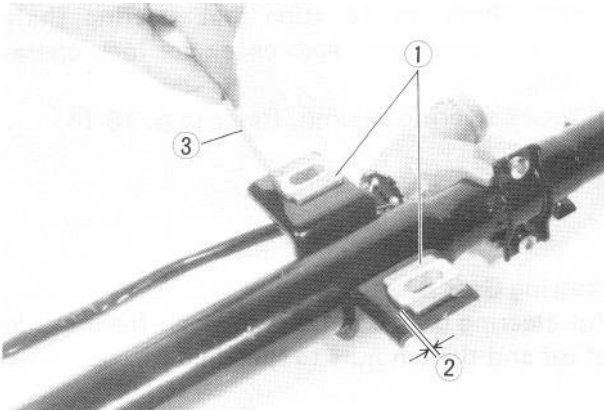
If the specified value is not attained even after readjustment, it is advisable to replace the gear box with a new gear box ass'y.

## 18-6. CHECKING STEERING COLUMN FOR ACCIDENT DAMAGE

Cars involved in accidents resulting in body damage or where the steering column has been impacted may also have a damaged or misaligned steering column.

### Checking Procedure

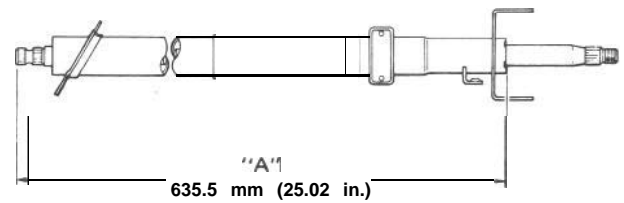
- 1) Check capsules on steering column bracket; all should be within 1.0 mm (0.039 in) from the bottom of slots. If not, steering column assembly should be replaced. Use thickness gauge for convenience.



- |   |  |
|---|--|
| <p>1. Capsules<br/>Each capsule should be within 0 – 1.0 mm (0 – 0.039 in.) from the bottom of slot. If not, replace column assembly.</p> | <p>2. Within 0 – 1.0 mm (0-0.039 in)</p> <p>3. Thickness gauge</p> |
|---|--|

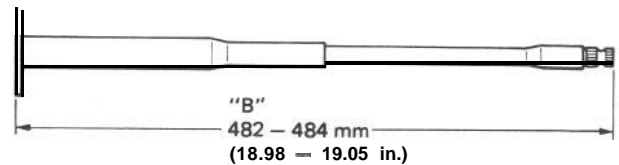
**Fig. 18-23**

- 2) Take measurement "A" as shown. If it is shorter than specified length, replace column assembly with new one.



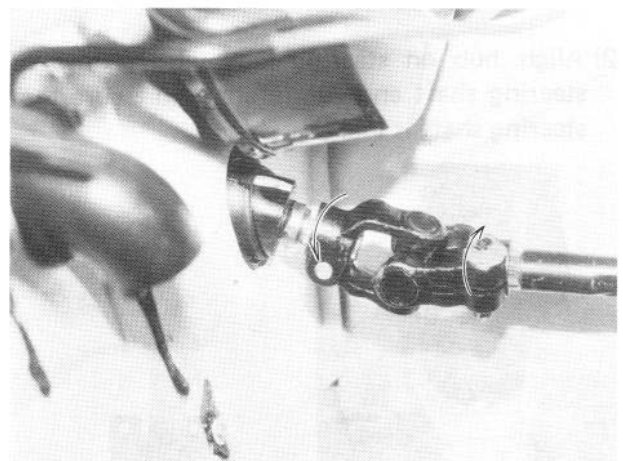
**Fig. 18-24**

- 3) Take measurement "B" of steering lower shaft as shown. If it is shorter than specified length, replace it with new one.



**Fig. 18-25**

- 4) Check steering shaft joints and shaft for any damages such as crack, breakage, malfunction or excessive play. If anything is found faulty, replace.



**Fig. 18-26**

- 5) Check steering shaft for smooth rotation. If found defective, replace as column assembly.



## 18-7. IMPORTANT STEPS IN REINSTALLATION

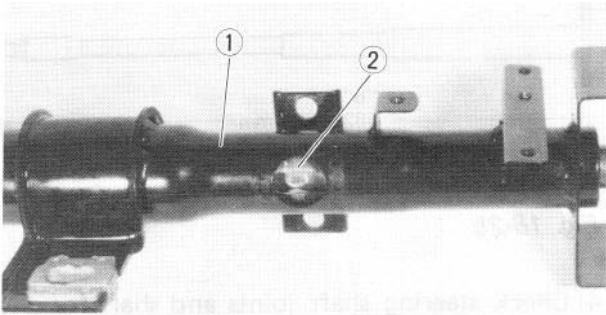
### NOTE:

For installation, it is important that only the specified screws, bolts, and nuts be used as designated and that they are tightened to the specified torque.

Reverse removal procedure for installation, noting the following.

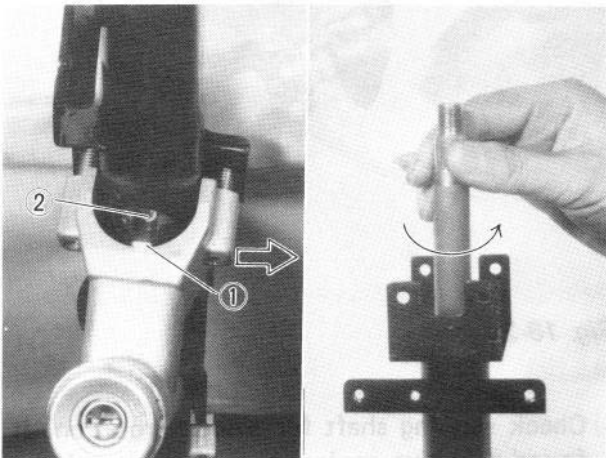
### Steering Lock

- 1) Position groove of steering shaft in the center of hole in column.



**Fig. 18-27** 1. Steering column  
2. Steering shaft

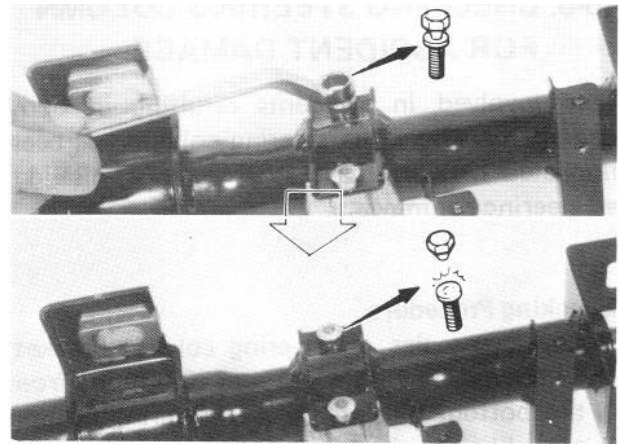
- 2) Align hub on steering lock with groove of steering shaft and rotate shaft to assure that steering shaft is locked.



**Fig. 18-28** 1. Hub  
2. Groove

- 3) Tighten 2 new bolts until head of each bolt is broken off.

18-12

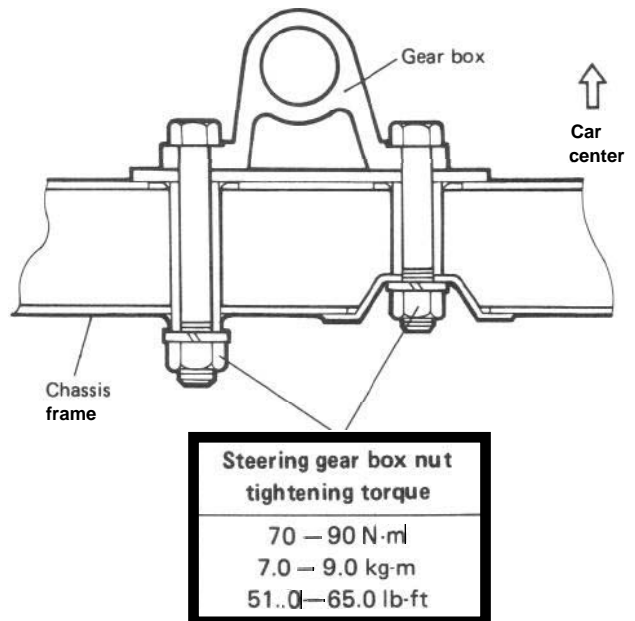


**Fig. 18-29**

- 4) Turn ignition key to "ACC" or "ON" position and check to be sure that steering shaft rotates smoothly. Also check for lock operation.
- 5) Install steering column. Refer to p. 18-14.

### Steering Gear Box

Put steering gear box bolts through from inside of car and tighten nuts to specified torque.



**Fig. 18-29-1**

### Steering Damper

- 1 install steering damper with larger diameter hole end directed toward pitman arm and hole in outer shell downward.
- 1 Install steering damper stay, directing its circular boss side upward.
- 1 Mount steering damper and steering damper stay bolts from the top.
- 1 Torque steering damper pin nut and damper nut to specification while directing steering to straightforward state (with pitman arm in parallel with center line of car).

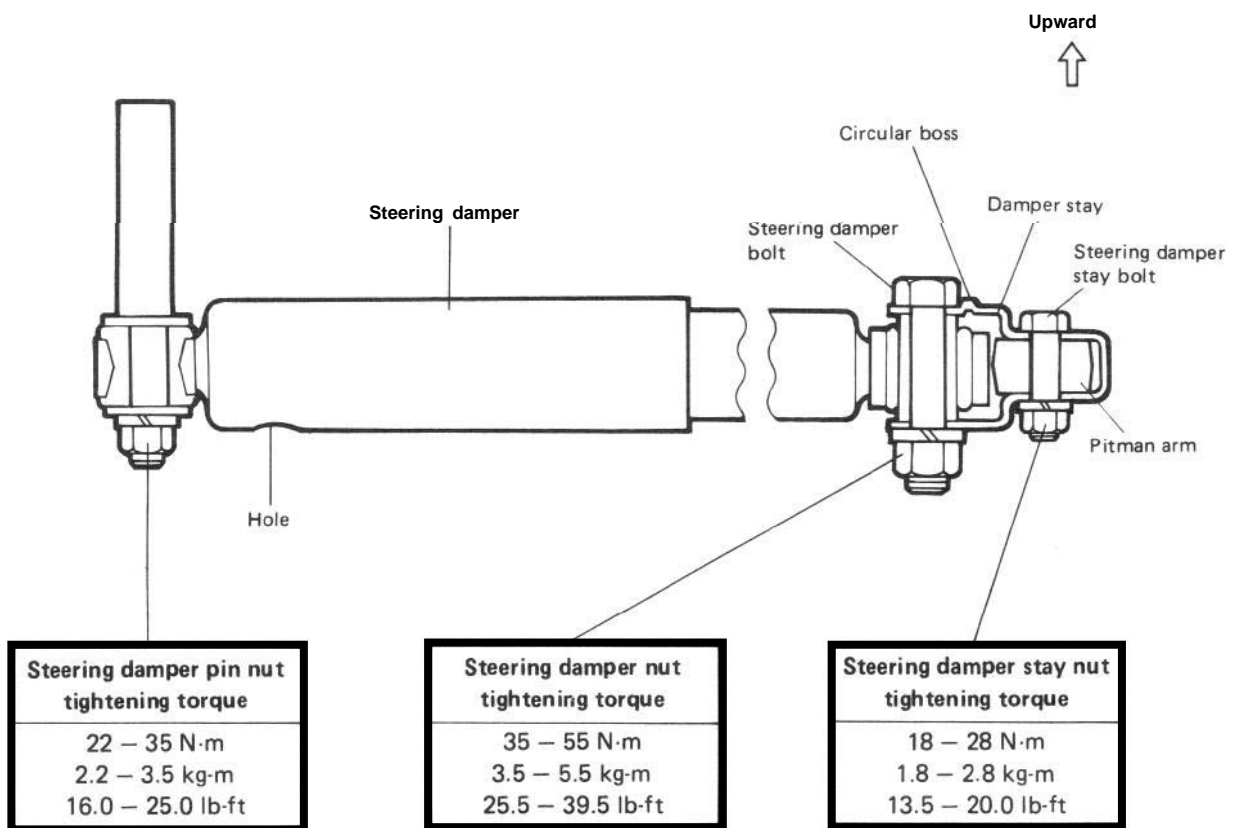


Fig. 18-29-2

# Steering Column

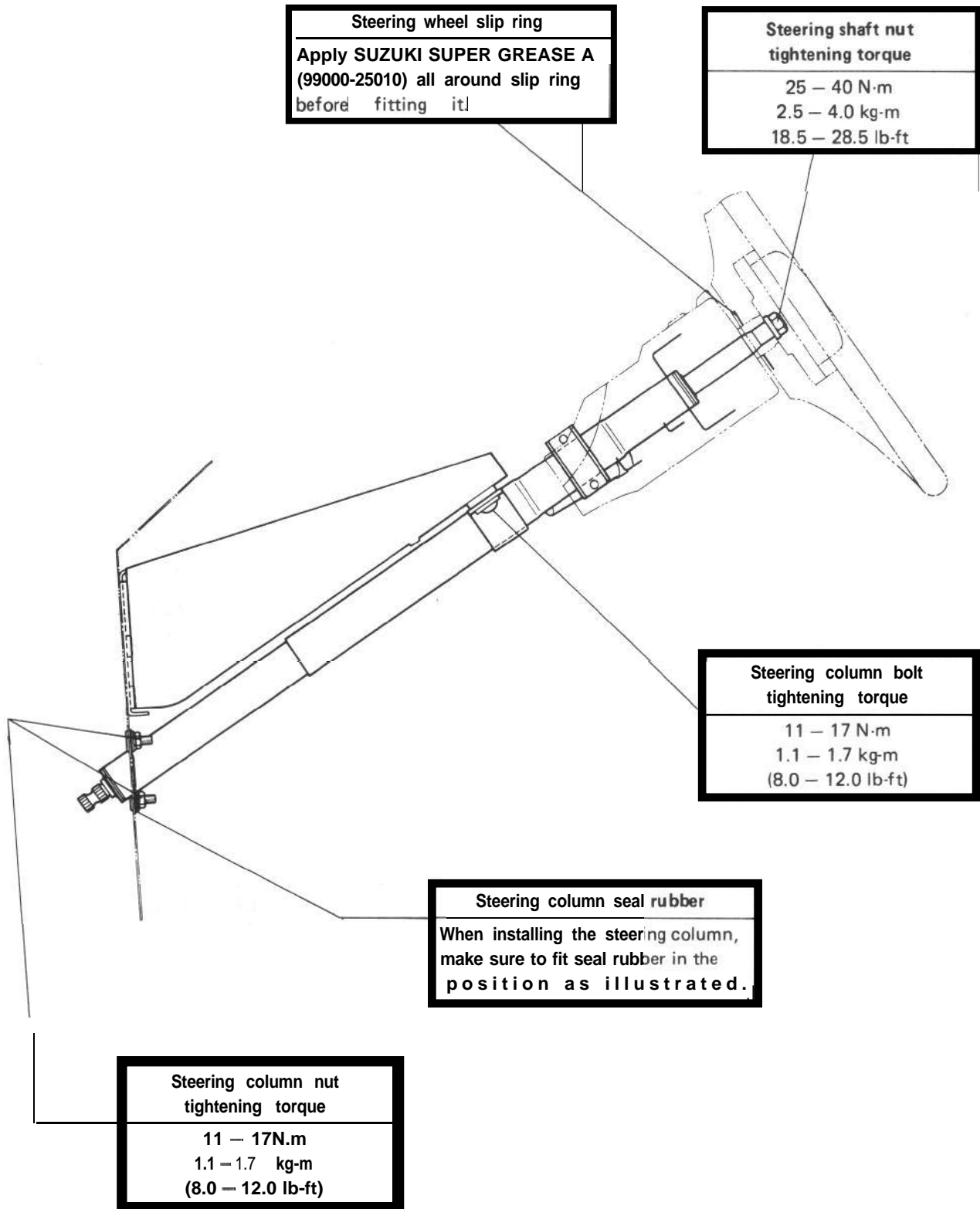


Fig. 18-30



## Steering Lower Shaft and Joint

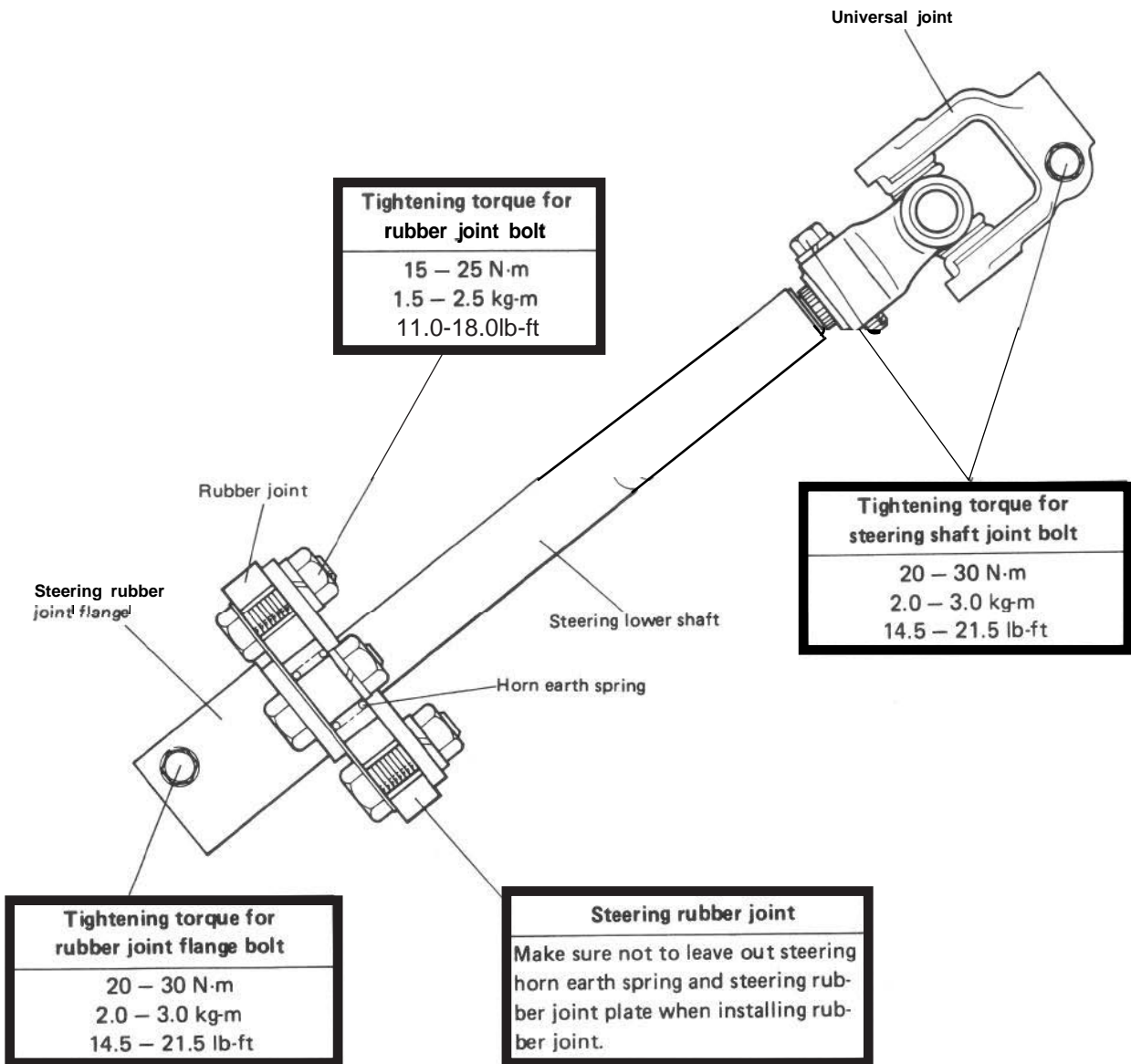


Fig. 18-31

### Steering Handwheel

Two requirements must be met, among others, in installing and setting steering wheel: 1) check to be sure that handwheel play meets specification, and 2) set it in such a way that, with front wheels in straightforward state, its two outer spokes are horizontal.

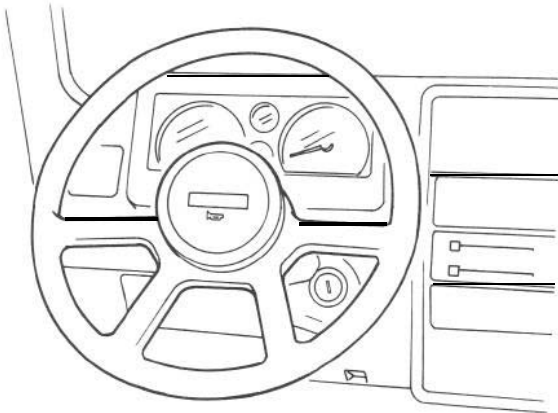
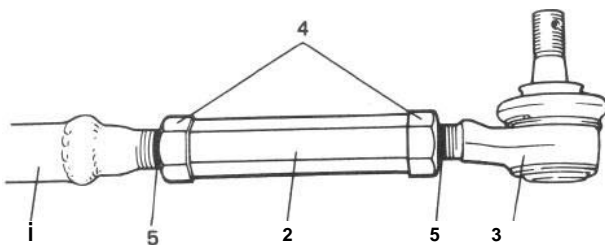


fig. 18-32

### Tie Rod and Tie Rod End

1) Install tie rod end to tie rod, aligning each lock nut to respective marks scribed before disassembly.



1. Tie rod
2. Turnbuckle
3. Tie rod end
4. Lock nut
5. Marking to be made

fig. 18-33

- 2) Connect tie rod end to knuckle and tie rod to drag rod. Tighten castle nut until holes for split pin are aligned, but only within specified torque.
- 3) Bend split pin.
- 4) Inspect for proper toe (Refer to 18-8 WHEEL ALIGNMENT).
- 5) After confirming proper toe, tighten tie rod end lock nuts to specified torque.

## 18-8. WHEEL ALIGNMENT

Front alignment refers to the angular relationship between the front wheels, the front suspension attaching parts and the ground. Generally, the only adjustment required for front alignment is toe setting. Camber and caster can't be adjusted. Therefore, should camber or caster be out of specification due to the damage caused by hazardous road conditions or collision, whether the damage is in chassis frame (body) or in suspension should be determined and damaged body should be repaired or damaged suspension should be replaced.

### Toe Setting

Toe is the turning in or out of the front wheels. The purpose of a toe specification is to ensure parallel rolling of the front wheels (Excessive toe-in or toe-out may increase tire wear). Amount of toe can be obtained by subtracting "A" from "B" as shown in figure and therefore is given in mm (in.).

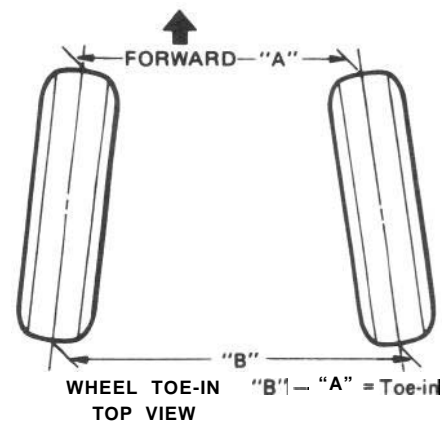


fig. 18-34

## Camber

Camber is the tilting of the front wheels from the vertical, as viewed from the front of the car. When the wheels tilt outward at the top, the camber is positive. When the wheels tilt inward at the top, the camber is negative. The amount of tilt is measured in degrees.

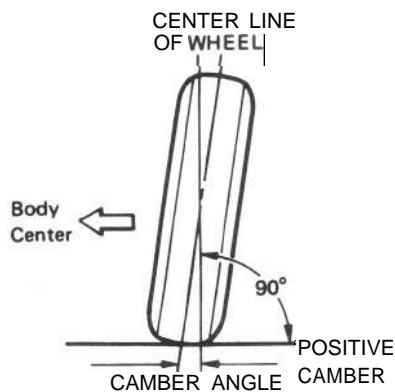


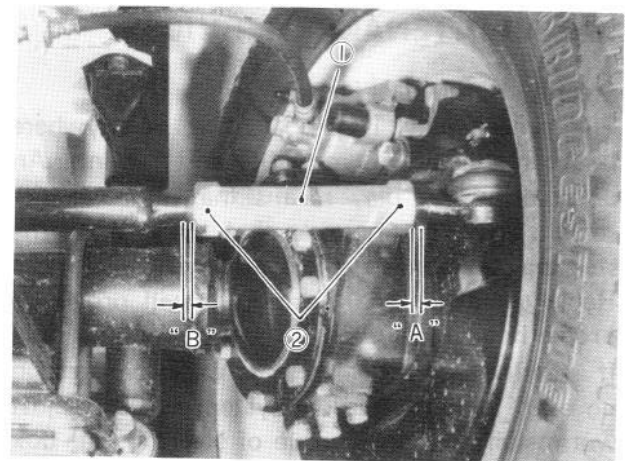
Fig. 18-35

## Toe Adjustment

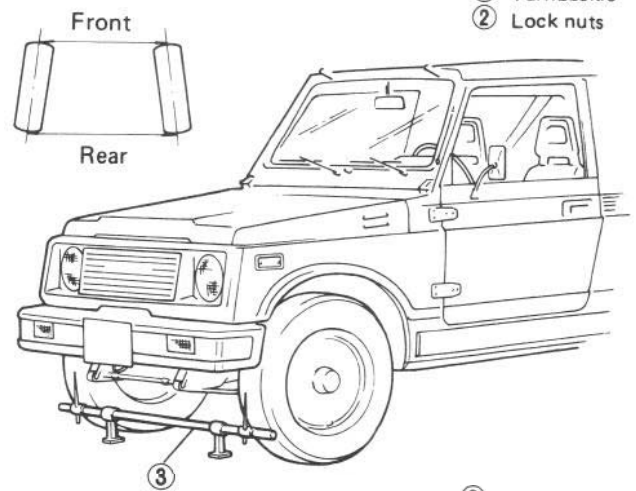
1. Before making any adjustment affecting toe setting, the following checks and inspections should be made to insure correctness of alignment readings and alignment adjustments:

- 1) Check all tires for proper inflation pressures and approximately the same tread wear.
- 2) Check steering and suspension system for looseness. If excessive looseness is noted, it must be corrected before adjusting.
- 3) Check for run-out of wheels and tires.
- 4) Consideration must be given to excess loads, such as tool boxes. If this excess load is normally carried in the car, it should remain in the car during alignment checks.
- 5) Consider condition of the equipment being used to check alignment and follow manufacturer's instructions.
- 6) Regardless of equipment used to check alignment, the car must be on a level surface both fore and aft and transversely.
- 7) Check to be sure that front wheels are set in straightforward driving position.

2. Toe is adjusted by changing tie rod length. Loosen tie rod end lock nuts first and then rotate turnbuckle ① to align toe-in to specification. At this time, thread length "A" and "B" should be equal. After adjustment, tighten lock nuts to specified torque.



- ① Turnbuckle
- ② Lock nuts



- ③ Toe-in gauge

Fig. 18-36

## Camber and Caster Adjustment

Should camber or caster be found out of specifications upon inspection, locate its cause first. If it is in damaged, loose, bent, dented or worn suspension parts, they should be replaced. If it is in chassis frame (car body), repair it so as to attain specifications.

To prevent possible incorrect reading of camber or caster, car front end must be moved up and down a few times before inspection.

## Reference Information:

### SIDE SLIP:

For inspecting front wheel side slip with side slip tester:

Side slip limit: Less than 3 mm/m  
(Less than 0.118 in/3 ft)

If side slip exceeds this limit, toe-in or front wheel alignment may not be correct.

## 189. MAINTENANCE SERVICES

### Steering Handwheel Play

The wheel play is proper if it is anywhere between 10 and 30 mm (0.4 and 1.2 in.). An unusually large play means that the ball-and-socket joints are loose or that the wear in the steering gear box is excessively large.

Replacement of the worn joint will provide a proper handwheel play.

If steering handwheel play is excessive though no each joint of steering system rattles, adjust worm shaft starting torque of steering gear box by referring to item of "Adjustment of worm shaft starting torque."

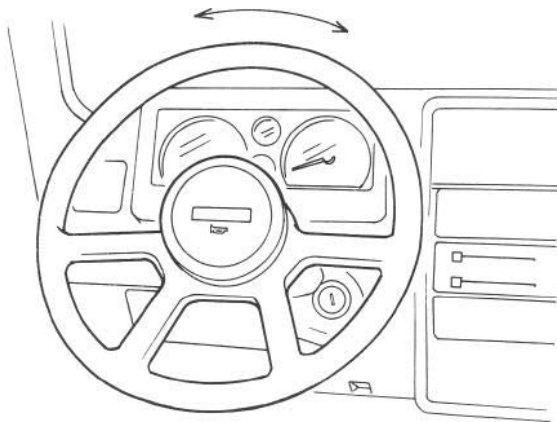


Fig. 18-37

### Steering Shaft Joint

Check universal joint of the steering shaft for rattle and damage, If rattle and damage is found, replace defective part with a new one.

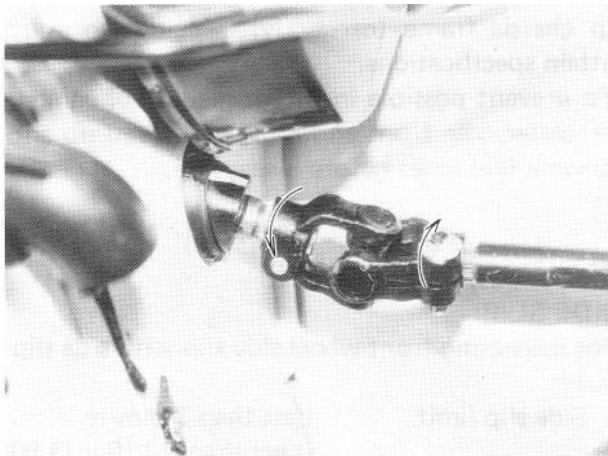


Fig. 18-38

### Steering Rubber joint

Inspect rubber joint for evidence of crack or breakage, and make sure that its bolts are tight.

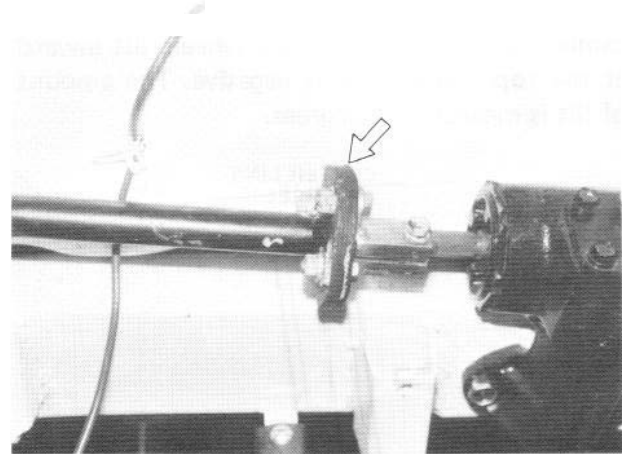


Fig. 18-39

### Steering Link & Tie Rod

Inspect steering link and tie rod for bend and rattle where they are joined. Inspect ball joint boots in steering system for leaks, detachment, tear or other damage. If one of such malconditions is found, replace defective part with a new one.

Check the following bolts and nuts ( ①—⑦ ) for tightness and retighten them as necessary.

Refer to "RECOMMENDED TORQUE SPECIFICATIONS" in this section for tightening torque.

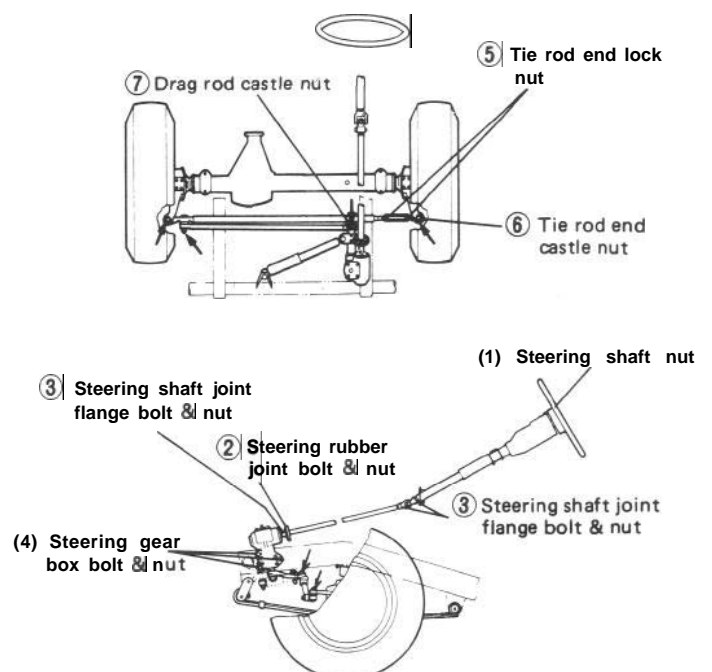


Fig. 18-40

### Steering Gear Box

Check steering gear box for evidence of oil leakage. If leakage is found, repair or replace and then refill specified oil to specified level.

Refer to “18-5 INSPECTION OF COMPONENT” in this section for steering gear box oil.

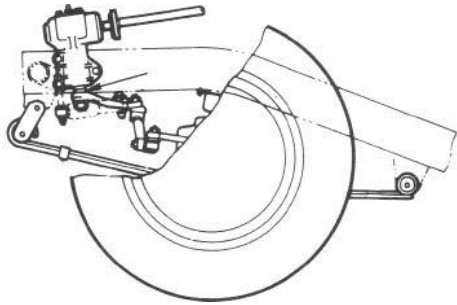


Fig. 18-41

### Tires

When replacement is necessary, the original equipment type tire should be used. Refer to Tire Placard.

Replacement tires should be of the same size, load range and construction as those originally on the car. Use of any other size or type tire may affect ride, handling, speedometer/odometer calibration, vehicle ground clearance and tire or snow chain clearance to body and chassis.

#### NOTE:

Do not mix different types of tires on the same car such as radial, bias and bias-belted tires except in emergencies, because car handling may be seriously affected and may result in loss of control.

It is recommended that new tires be installed in pairs on the same axle. If necessary to replace only one tire, it should be paired with the tire having the most tread, to equalize braking traction.

#### [Inspection]

- 1 Check tires for uneven or excessive wear, or damage. If defective, replace.
- 1 Check inflating pressure of each tire and, as necessary, adjust pressure to specification.
- 1 Check wheels for dent, crack or other damage.
- 1 Check wheel nuts for tightness.

Tightening torque for wheel nuts	50-80	N·m
	5.0 – 8.0	kg-m
	(36.5 – 57.5)	lb-ft

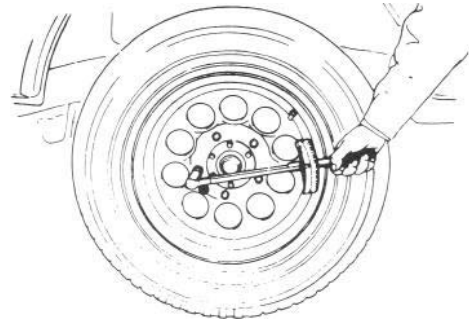


Fig. 18-42

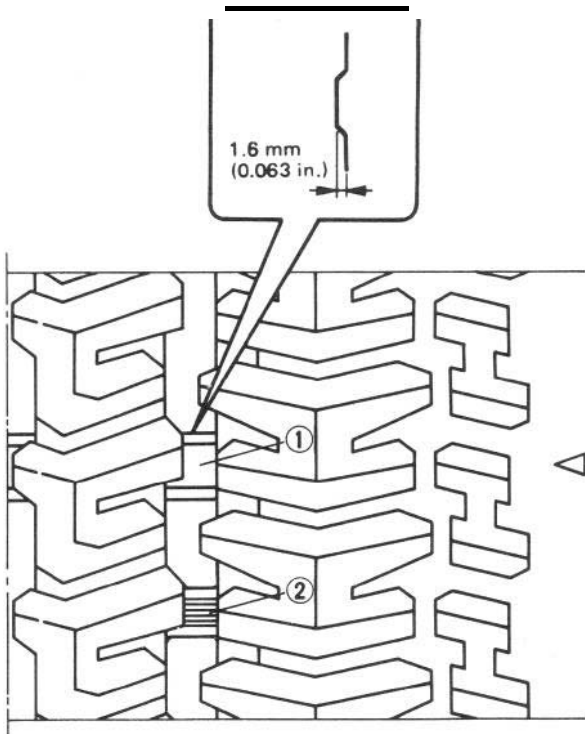
#### [Tire wear indicator]

Check wear indicator, and replace tire when its wear is the same level as the indicator.

Tire service limit	Less than 1.6 mm (0.063 in.) depth of tread at two places.
--------------------	--

#### NOTE:

The mud & snow tire has a platform to indicate wear in addition to tire tread wear indicator. It shows up when 50% of tire tread is worn out. When driving on muddy or snowy roads, check if its wear is the same level as the platform and if it does, replace the tire.



**Fig. 18-43** ① Tire tread wear indicator  
② Wear indicating platform

**[ Inflation of tires]**

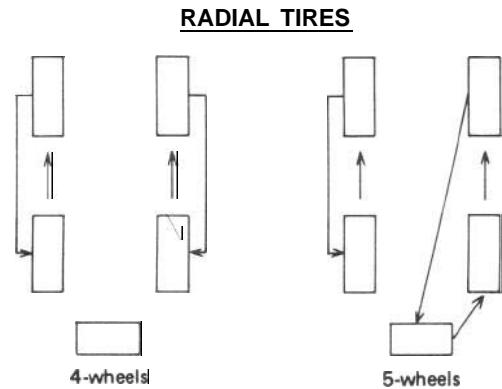
- 1 Tire inflation pressures are listed on the Tire Placard at driver's side of instrument panel.
- 1 Tire inflation pressures should be checked (including spare tire) at least monthly and when significantly changing the load in the car.
- 1 Always check tire inflation pressures when tires are "cold".
- 1 Always use tire pressure gauge when checking inflation pressure.
- 1 Be sure to reinstall tire inflation valve caps to prevent dirt and moisture from getting into valve core, as they may cause air leakage.
- 1 If air loss occurs while driving, do not drive on the deflated tire more than is needed to stop safely. Driving even a short distance on a deflated tire can damage a tire and wheel beyond repair.

**[Tire rotation]**

"Rotate" tires at the regular intervals in order to equalize tire wear and thereby make full use of each tire. Refer to below figure for the scheme of rotation. Adherence to this scheme prolongs tire life.

**NOTE:**

Before installing wheels, remove any build-up of corrosion on the wheel mounting surface and brake drum or disc mounting surface by scraping and wire brushing. Installing wheels without good metal-to-metal contact at the mounting surfaces can cause wheel nuts to loosen, which can later allow a wheel to come off while the car is moving.

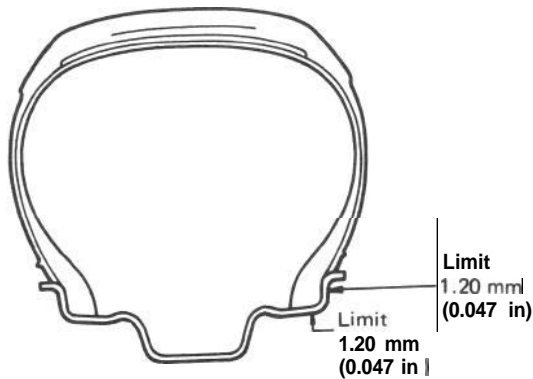


**Fig. 18-44**

**[Wheels]**

Wheels must be replaced if they are bent, dented, have excessive lateral or radial runout, leak air through welds, have elongated bolt holes, if lug nuts won't stay tight, or if they are heavily rusted. Wheels with greater runout than shown in below figure may cause objectional vibrations. Replacement wheels must be equivalent to the original equipment wheels in load capacity, diameter, rim width, offset and mounting configuration. A wheel of improper size or type may affect wheel and bearing life, brake cooling, speedometer/odometer calibration, car ground clearance and tire clearance to the body and chassis.





\*TOTAL INDICATOR READING  
 IGNORE INDICATOR "JUMPS"  
 DUE TO WELD SEAMS, PAINT  
 RUNS, SCRATCHES, ETC.

*Fig. 18-45*

Wheel repairs that use welding, heating, or peening are not approved. All damaged wheels should be replaced.

**[Tire demounting and mounting]**

Use a 'tire changing machine to mount or demount tires. Follow the equipment manufacturer's instructions. Do not use hand tools or tire irons alone to change tires as they may damage the tire beads or wheel rim.

Rim bead seats should be cleaned with a wire brush or coarse steel wool to remove lubricants, old rubber and light rust. Before mounting or demounting a tire, the bead area should be well lubricated with an approved tire lubricant.

After mounting, inflate to 220kPa (32 psi) so that beads are completely seated.

**WARNING:**

Do not stand over tire when inflating. Bead may break when bead snaps over rim's safety hump and cause serious personal injury.

Do not exceed 240kPa (35 psi) pressure when inflating. If 220kPa (32 psi) pressure will not seat beads, deflate, re-lubricate and reinflate. Over inflation may cause the bead to break and cause serious personal injury.

Inflate to specified pressure.

**[Tire repair]**

There are many different materials and techniques on the market to repair tires. As not all of these work on all types of tires, tire manufacturers have published detailed instructions on how and when to repair tires. These instructions can be obtained from the tire manufacturer.

## 18-10. RECOMMENDED TORQUE SPECIFICATIONS

Fastening parts	Tightening torque		
	N·m	kg-m	lb-ft
Steering shaft nut	25 – 40	2.5 – 4.0	18.5 – 28.5
Steering shaft rubber joint bolt	15 – 25	1.5 – 2.5	11.0 – 18.0
Steering shaft joint flange bolt	20 – 30	2.0 – 3.0	14.5 – 21.5
Steering gear box nut	70 – 90	7.0 – 9.0	51.0 – 65.0
Drag rod castle nut	30 – 70	3.0 – 7.0	22.0 – 50.5
Tie rod end castle nut	30 – 55	3.0 – 5.5	22.0 – 39.5
Tie rod end lock nut	70 – 100	7.0 – 10.0	51.0 – 72.0
Steering damper stay nut	18 – 28	1.8 – 2.8	13.5 – 20.0
Steering damper nut	35 – 55	3.5 – 5.5	25.5 – 39.5
Steering damper pin nut	22 – 35	2.2 – 3.5	16.0 – 25.0
Steering column bolt & nut	11 – 17	1.1 – 1.7	8.0 – 12.0



# SECTION 19

## BRAKES

### CONTENTS

19-1. GENERAL DESCRIPTION .....	19-2
19-2. FRONT DISC BRAKE .....	19-14
19-3. REAR DRUM BRAKE .....	19-20
19-4. MASTER CYLINDER .....	19-27
19-5. BRAKE BOOSTER .....	19-30
19-6. PARKING BRAKE .....	19-38
19-7. BRAKE PIPES AND HOSES .....	19-39
19-8. MAINTENANCE SERVICE .....	19-42
19-9. TORQUE SPECIFICATION.. .....	19-49

**NOTE:**

All brake fasteners are important attaching parts in that they could affect the performance of vital parts and systems, and/or could result in major repair expense. They must be replaced with one of same part number or with an equivalent part if replacement becomes necessary. Do not use a replacement part of lesser quality or substitute design. Torque values must be used as specified during reassembly to assure proper retention of all parts. There is to be no welding as it may result in extensive damage and weakening of the metal.

**WARNING:**

When servicing wheel brake parts, do not create dust by grinding, sanding brake linings, or by cleaning wheel brake parts with a dry brush or with compressed air. Many wheel brake parts contain asbestos fibers which can become airborne if dust is created during servicing. Breathing dust containing asbestos fibers may cause serious bodily harm. A water dampened cloth or water based solution should be used to remove any dust on brake parts. Equipment is commercially available to perform this washing function. These wet methods will prevent asbestos fibers from becoming airborne.

## 19-1. GENERAL DESCRIPTION

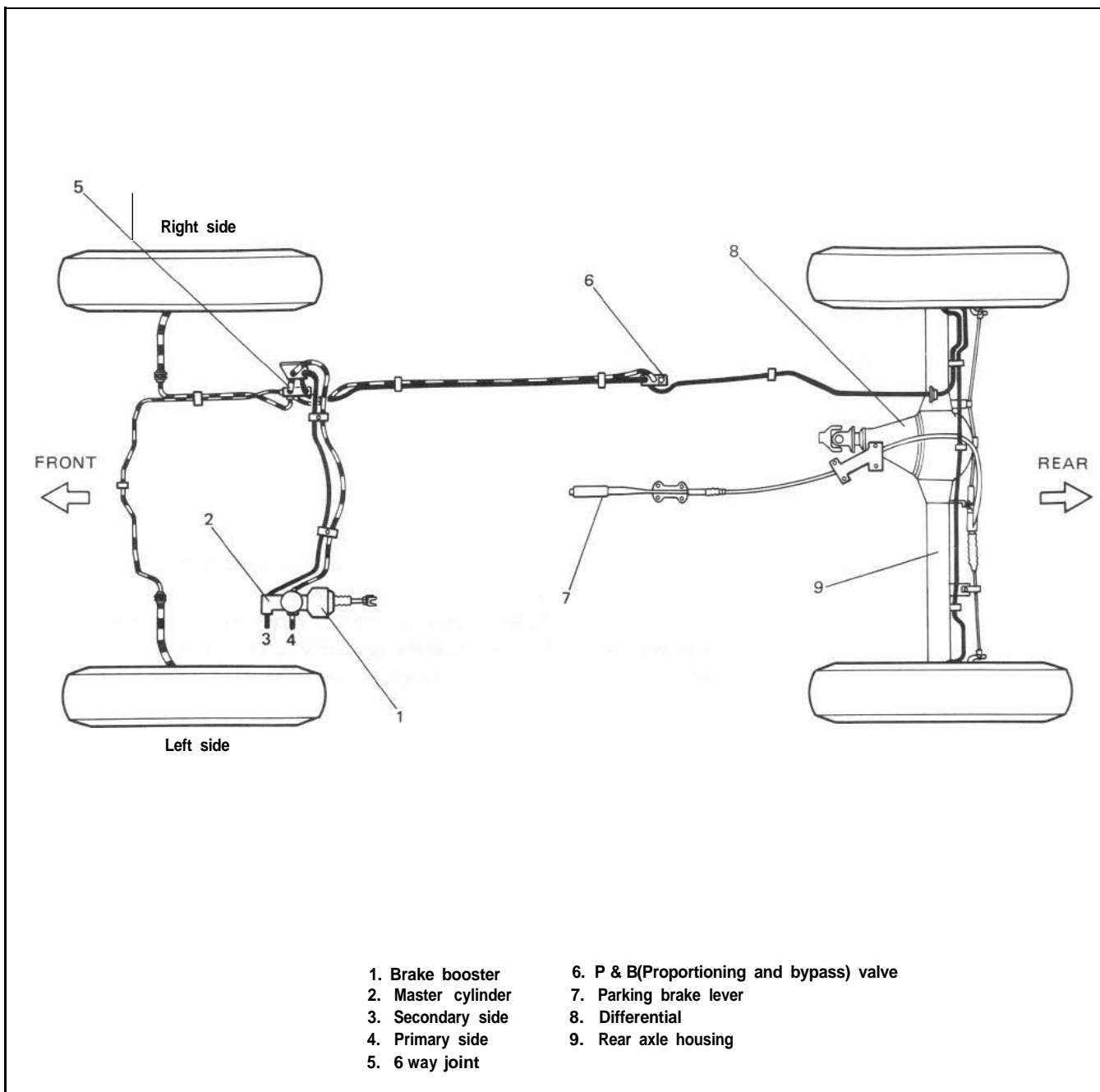
When the foot brake pedal is depressed, hydraulic pressure is developed in the master cylinder to actuate pistons (two in front and four in rear).

The master cylinder is a tandem master cylinder. Two brake pipes are connected to the master cylinder and they make two independent circuits. One connects the front brakes (right & left) and the other connects the rear brakes (right & left).

The proportioning and bypass valve (P&B valve) is included within the brake circuit which connects the master cylinder and the rear wheel brake.

In this brake system, the disc brake type is used for the front wheel brake and a drum brake type (leading/trailing shoes) for the rear wheel brake.

The parking brake system is mechanical. It applies brake force to only rear wheels by means of the cable and mechanical linkage system. The same brake shoes are used for both parking and foot brakes.



**Fig. 19-1**

## MASTER CYLINDER

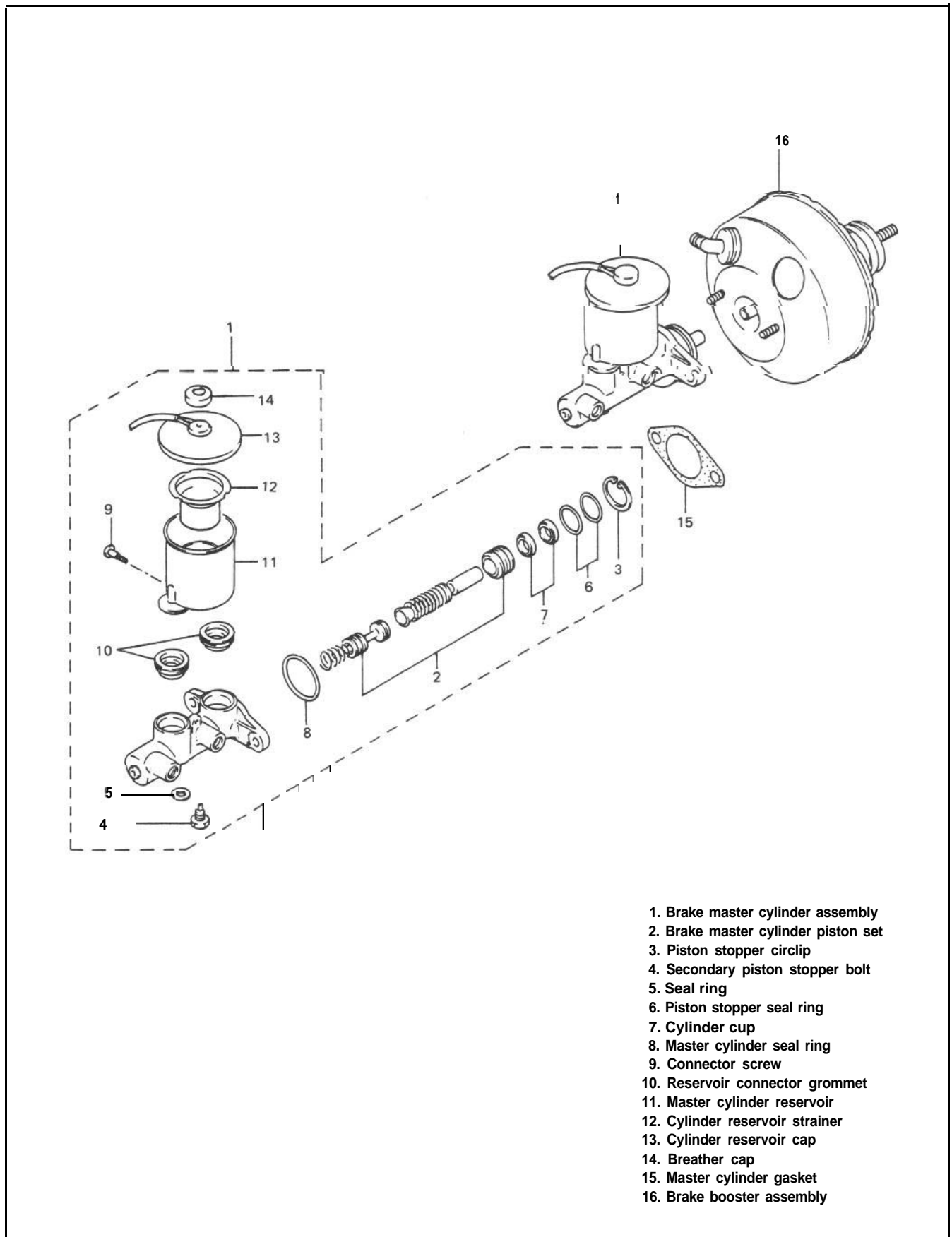


Fig. 19-2

## MASTER CYLINDER ASSEMBLY

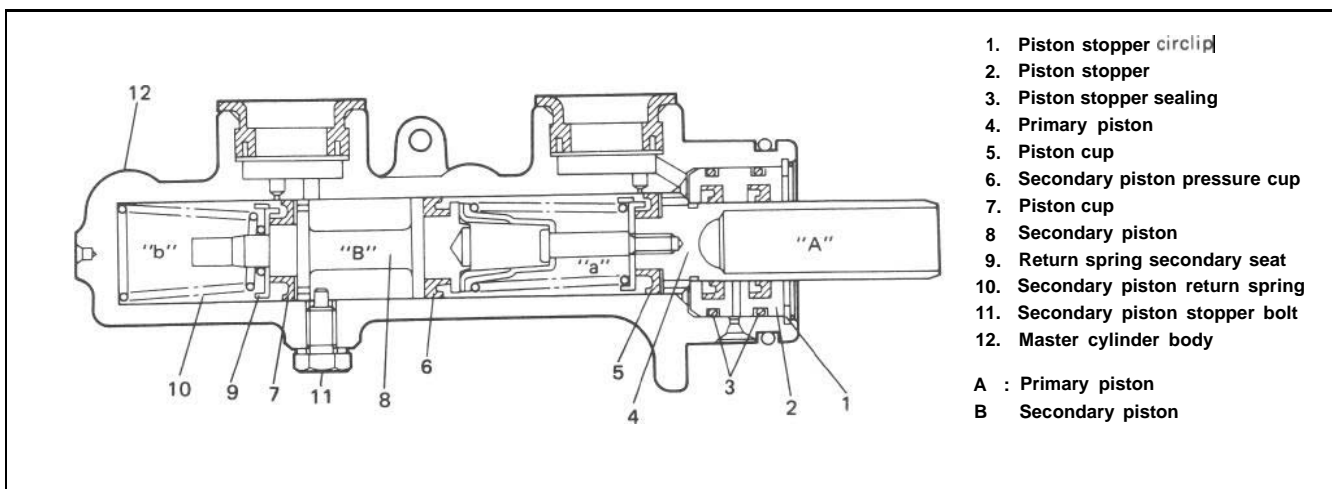
### [GENERAL DESCRIPTION]

The master cylinder has two pistons and three piston cups. Its hydraulic pressure is produced in the primary ("a" in the below figure) and secondary ("b") chambers. The hydraulic pressure produced in the primary chamber ("a") acts on the front wheel brakes (right & left).

Also, the hydraulic pressure produced in the secondary chamber ("b") acts on the rear wheel brakes (right & left).

### NOTE:

Replace all components included in repair kits to service this master cylinder. Lubricate rubber parts with clean, fresh brake fluid to ease assembly. Do not use lubricated shop air on brake parts as damage to rubber components may result. If any hydraulic component is removed or brake line disconnected, bleed the brake system. The torque values specified are for dry, unlubricated fasteners.



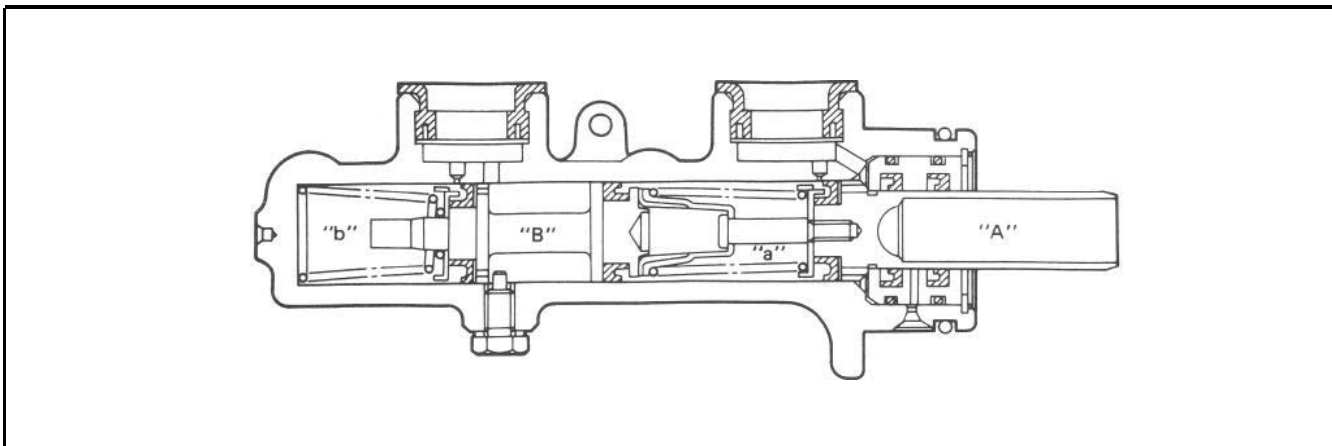
**Fig. 19-3**

### [Master cylinder OPERATION]

#### Normal operation

Depressing the brake pedal forces the primary piston "A" to move to the left in the below figure and consequently the hydraulic pressure is produced in the chamber "a".

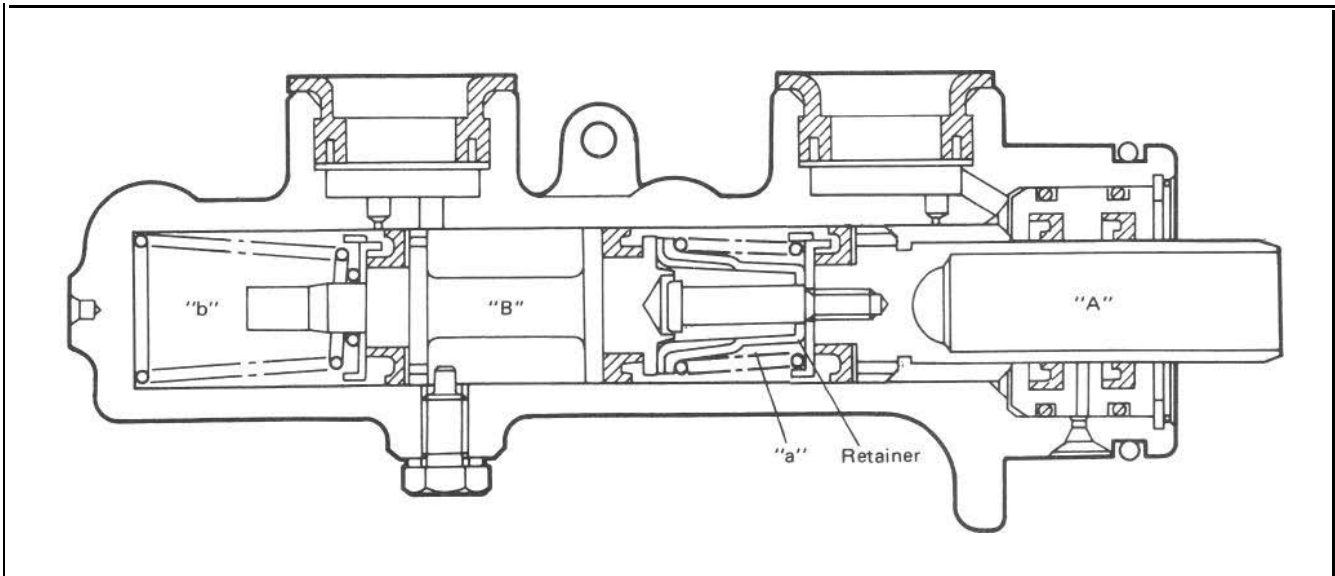
By means of this pressure and the return spring force, the secondary piston "B" is also pushed to the left and thus the hydraulic pressure is produced in the chamber "b".



**Fig. 19-3-1**

**One-circuit operation (Primary chamber "a" circuit failure)**

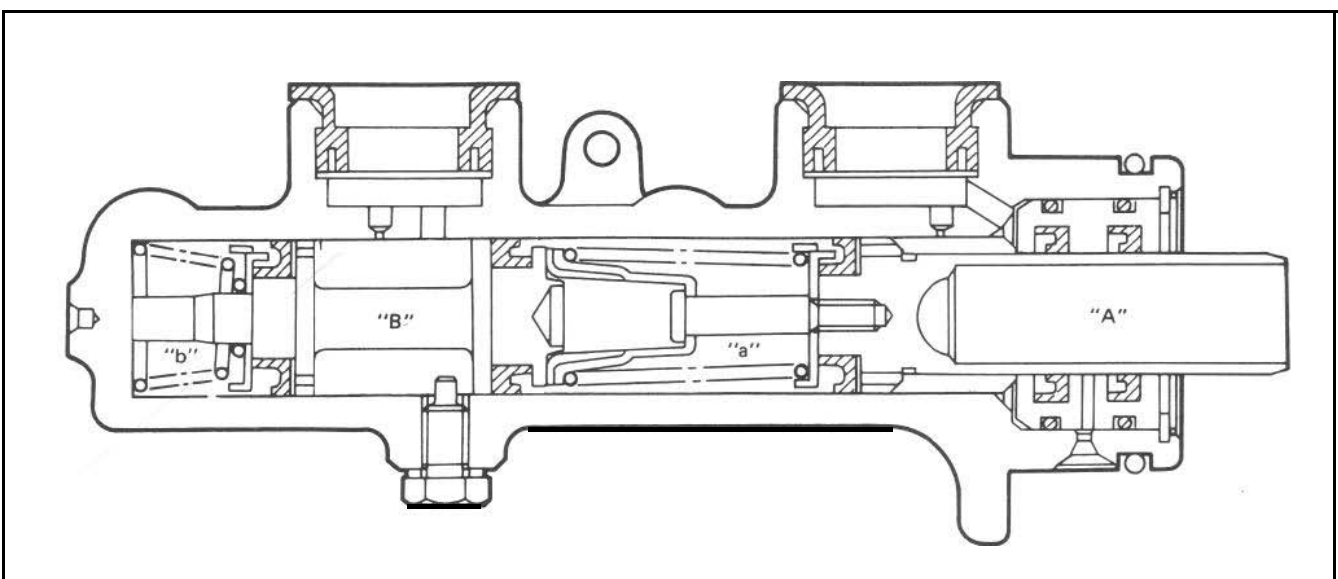
Depressing the brake pedal forces the primary piston "A" to move as described previously, but since the brake circuit connected to the chamber "a" cannot hold the pressure, no pressure is produced in the fluid immediately ahead of the piston "A". The piston "A" keeps moving while compressing the spring and when it reaches the retainer, the piston "B" is pushed and begins to move. This causes the pressure to rise in the chamber "b" and the pressure acts on rear wheel brakes (right & left).



**Fig. 19-4**

**One-circuit operation (Secondary chamber "b" circuit failure)**

In this case, the leftward movement of the piston "A" has but little effect in causing the fluid pressure to rise in the chamber "a" in the beginning, because the initial rise of the fluid pressure causes the piston "B" to promptly yield and move to the left. However, when the forward end of the piston "B" comes to the head of the cylinder and stops there, the leftward movement of the piston "A" becomes effective. Thus the fluid pressure is produced in the chamber "a" and it acts on front wheel brakes (right & left). The below figure shows secondary piston "B" at halt.



**Fig. 19-4**

## DISC BRAKE CALIPER ASSEMBLY

### [GENERAL DESCRIPTION]

This caliper has a single 51.1 mm (2.012 in.) bore and is mounted to the brake caliper holder with two mounting bolts. Hydraulic force, created by applying force to the brake pedal, is converted by the caliper to friction. The hydraulic force acts equally against the piston and the bottom of the caliper bore to move the piston outward and to move (slide) the caliper inward, resulting in a clamping action on the disc. This clamping action forces the pads (linings) against the disc, creating friction to stop the car.

For details, refer to OPERATION in the next page.

### NOTE:

Lubricate parts as specified. Do not use lubricated shop air on brake parts as damage to rubber components may result. If any component is removed or line disconnected, bleed the brake system. Replace pads in axle sets only. The torque values specified are for dry, unlubricated fasteners.

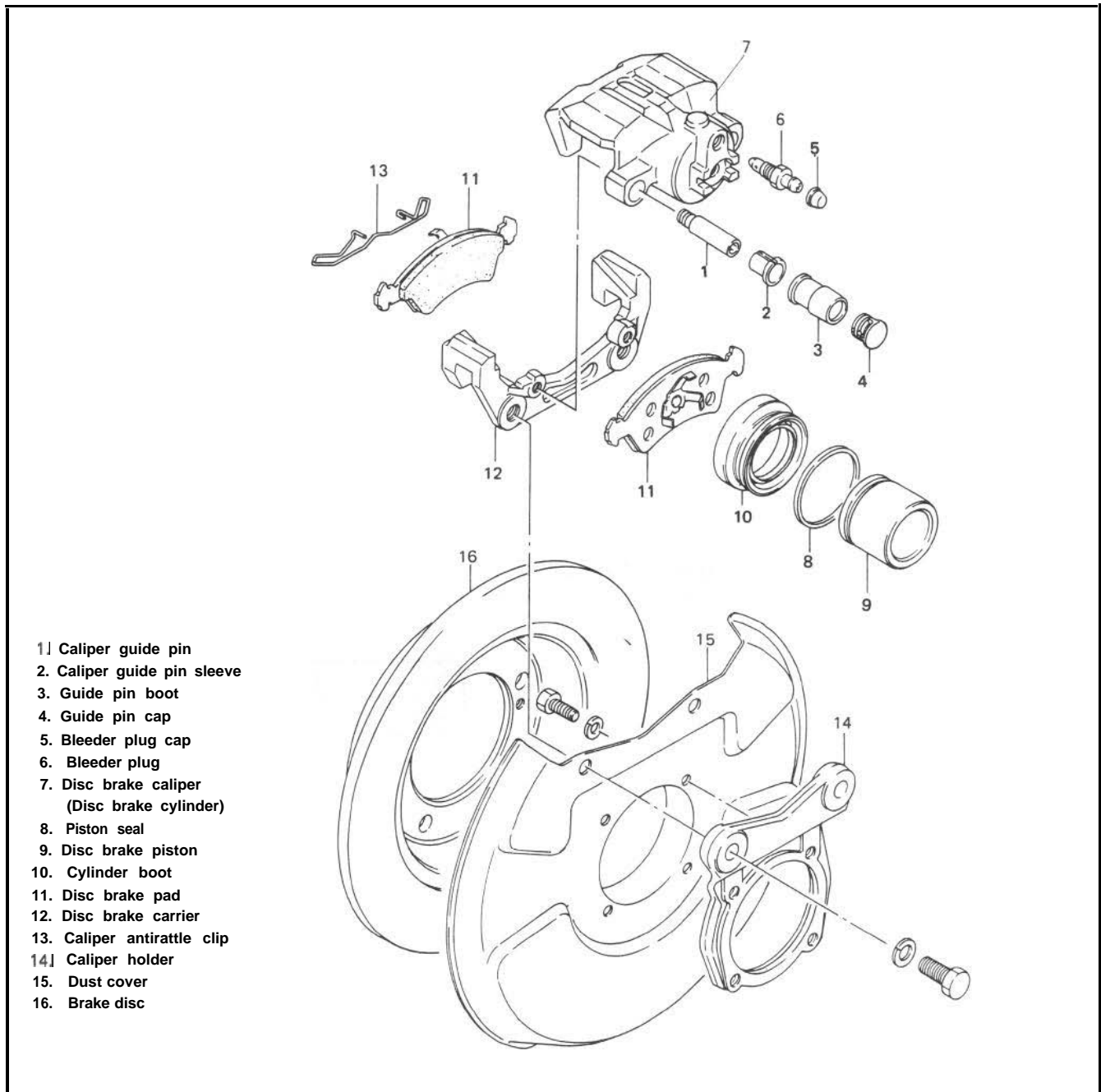
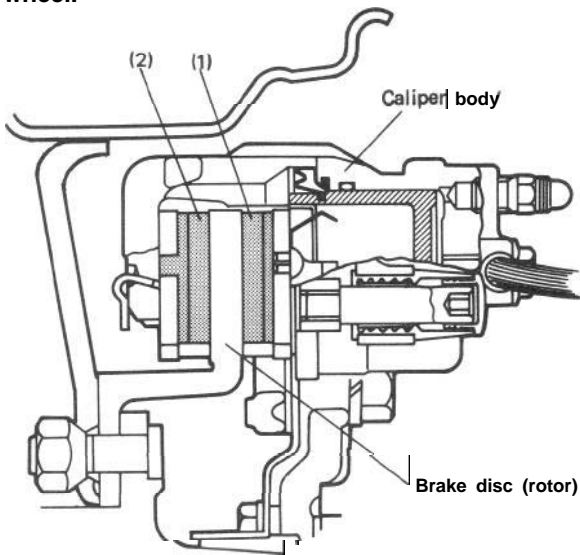


Fig. 19-5

**[Caliper OPERATION]**

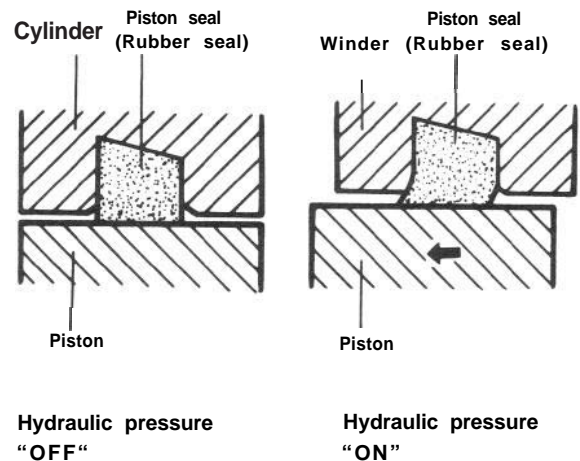
**Single piston floating caliper type**

The single piston floating caliper type brake is employed in this model. One cylinder and one piston are used for this type. (The cylinder is constructed as a monoblock with the caliper.) Fluid pressure generated in the cylinder causes the pad (1) on the piston side to press against the disc. At the same time, the floating type caliper body is moved to the right by the cylinder pressure, as shown in below figure, which pulls pad (2) against the disc and so brakes the wheel.



**Fig. 19-6**

The disc brake has no servo assistance as in drum braking, and it is necessary to increase the working pressure of the piston and pad. For this purpose, the wheel cylinder has a large bore. Even only a little change in clearance between the disc and pad has therefore a large influence on the brake pedal stroke. It is necessary to have the clearance adjusted to the minimum at all times, by means of the piston (rubber) seal.



**Fig. 19-7**

**Clearance correction**

When oil pressure is applied to the piston, the piston moves forward. The rubber seal, which exerts considerable pressure against the piston, moves with the cylinder. However, as a part of the rubber seal has been fixed into a groove in the cylinder, the shape of the rubber seal is distorted toward internal end of the cylinder, as shown in above figure. When pressure is taken off from the foot brake pedal and fluid pressure is released from the piston, a restoring force is generated at the seal and pushes the piston back. As the pads wear away and the clearance between the disc and pads becomes larger, the piston moves a larger distance. The seal then could change in shape further but, since the end of the seal is fixed into the groove in the cylinder, the distortion is limited to the same amount as previously described. The piston moves further to cover the distance of clearance. The piston returns by the same distance and the rubber seal recovers its shape as described above and thus the clearance between the disc and pads are maintained in adjustment.

## DRUM BRAKE ASSEMBLY (Rear Wheel Brake)

### [GENERAL DESCRIPTION]

The drum brake assembly has a self shoe clearance adjusting system so that drum-to-shoe clearance is maintained appropriate at all times. For details, refer to OPERATION in the next page.

### NOTE:

Replace all components included in repair kits used to service this drum brake. Lubricate parts as specified.

### WARNING:

When servicing wheel brake parts, do not create dust by grinding or sanding brake linings or by cleaning wheel brake parts with a dry brush or with compressed air. (A water dampened cloth should be used.) Many wheel brake parts contain asbestos fibers which can become airborne if dust is created during servicing. Breathing dust containing asbestos fibers may cause serious bodily harm. If any hydraulic component is removed or brake line disconnected, bleed the brake system. The torque values specified are for dry, unlubricated fasteners.

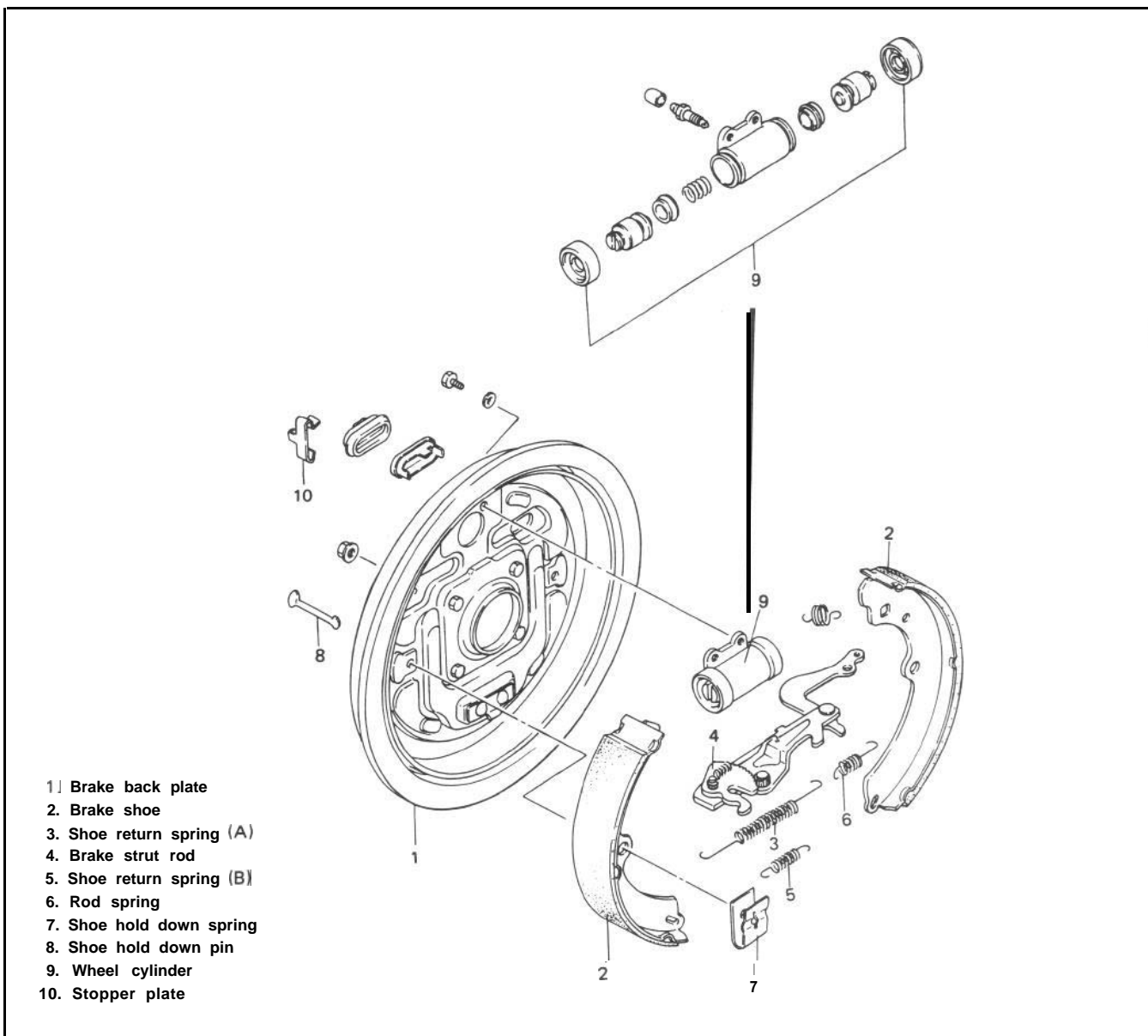


Fig. 19-8



**[Rear brake OPERATION]**

With the general drum brake type, when the brake pedal is depressed, two pistons in the wheel cylinder force the brake shoes outward, restraining the turn of the drum.

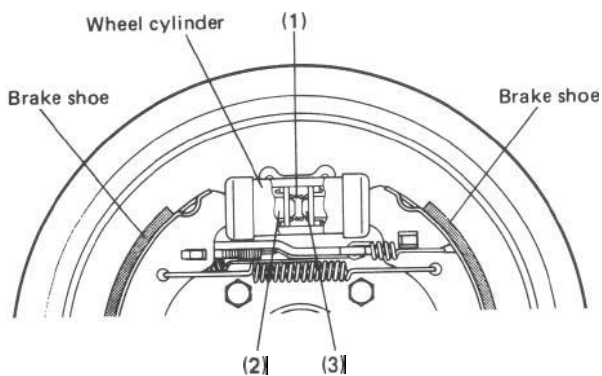
The more the brake shoes get worn, the longer distance the pistons must move. As a result, the brake pedal travel (pedal-to-wall clearance) increases. Then the shoe clearance must be adjusted by the shoe adjusting screws. Thus periodical adjustment is required for the drum brake type in general.

This rear brake is provided with a self-adjusting system which automatically adjusts the shoe-to-drum clearance (pedal-to-wall clearance) caused by such brake shoe wear.

**Clearance correction**

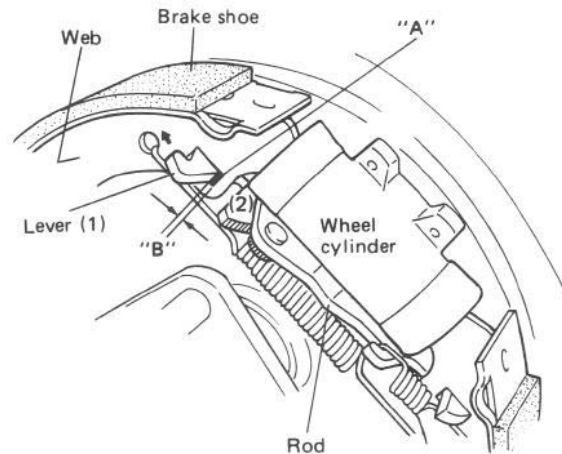
In each rear wheel cylinder, pistons, piston cups, and a piston spring (1) are installed. When the brake pedal is depressed, fluid pressure is applied to the inside of the chamber on the piston (2), (3).

Being actuated by this pressure, the piston (2) moves to the left (piston (3) moves to the right) in the following figure and presses the brake shoe against the brake drum, thus producing brake force.



**Fig. 19-9**

At this time, the distance the brake shoe moves is "B", that is, the distance that "A" (the end of the long hole made in the brake shoes web) moves till it contacts the lever (1) which is fitted in the long hole.



**Fig. 19-10**

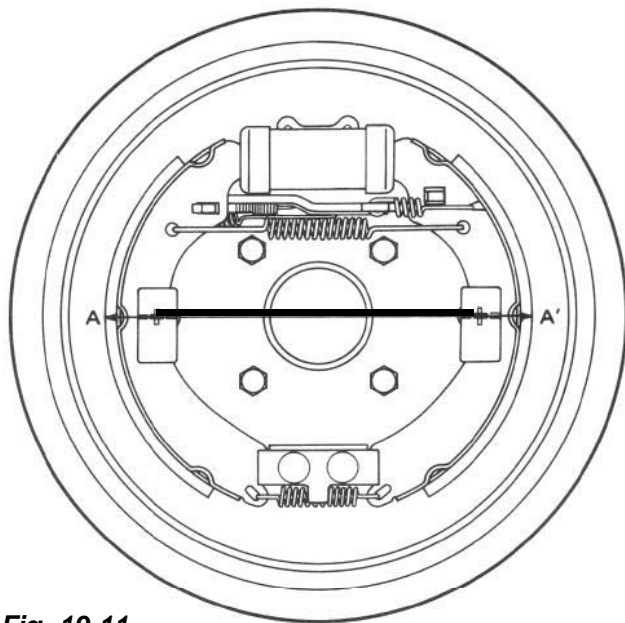
When the brake pedal is depressed, the piston and brake shoe move toward the brake drum side by the aforementioned distance "B" and "A" of the brake shoe web contacts the lever (1). As the brake shoe gets worn and the brake shoe clearance becomes larger, the force applied to the lever (1) at the time of such a contact becomes larger. When it exceeds 10 – 12 kg (22 – 26 lbs), the "A" of the brake shoe web moves the lever (1) as much as the amount of the brake shoe lining wear toward the direction as shown with an arrow in the figure. Thus the shoe is forced against the drum and the brake force is produced.

The distance the lever (1) moves corresponds to the amount of wear. In accordance with the lever (1) movement, the fan-shaped ratchet (2) also moves, for they are assembled as a unit. The lever (1) and ratchet (2) remain in the positions as they moved until the shoe-to-drum clearance becomes even larger.

When the brake pedal is released, the brake shoe is allowed to move back by the amount of clearance "B" by means of the return spring. In this way, the brake shoe-to-drum clearance is automatically adjusted constant every time the brake pedal is depressed.

The brake shoe-to-drum clearance "B" corresponds to 0.6 – 0.8 mm (0.0236 – 0.0315 in.) in terms of the brake drum diameter  $A \leftrightarrow A'$ . And the amount adjusted by one notch of the ratchet corresponds to 0.20 mm (0.008 in.) in terms of the brake drum diameter  $A \leftrightarrow A'$ .

The spring provided in the wheel cylinder prevents the piston from moving back more than the specified brake shoe-to-drum clearance.



**Fig. 19-11**

## BOOSTER ASSEMBLY

### [GENERAL DESCRIPTION]

The booster is located between the master cylinder and the brake pedal. It is so designed that the force created when the brake pedal is depressed is mechanically increased combined with the engine vacuum. The booster has a diaphragm of  $\phi$  180 mm effective diameter. Its operation is described in the following pages.

### NOTE:

Use all components included in repair kits to service this booster. Lubricate rubber parts, where indicated, with silicone grease provided in kits. The torque values specified are for dry, unlubricated fasteners. If any hydraulic component is removed or brake line disconnected, bleed the brake system. Never lubricate any hydraulic component with silicone grease.

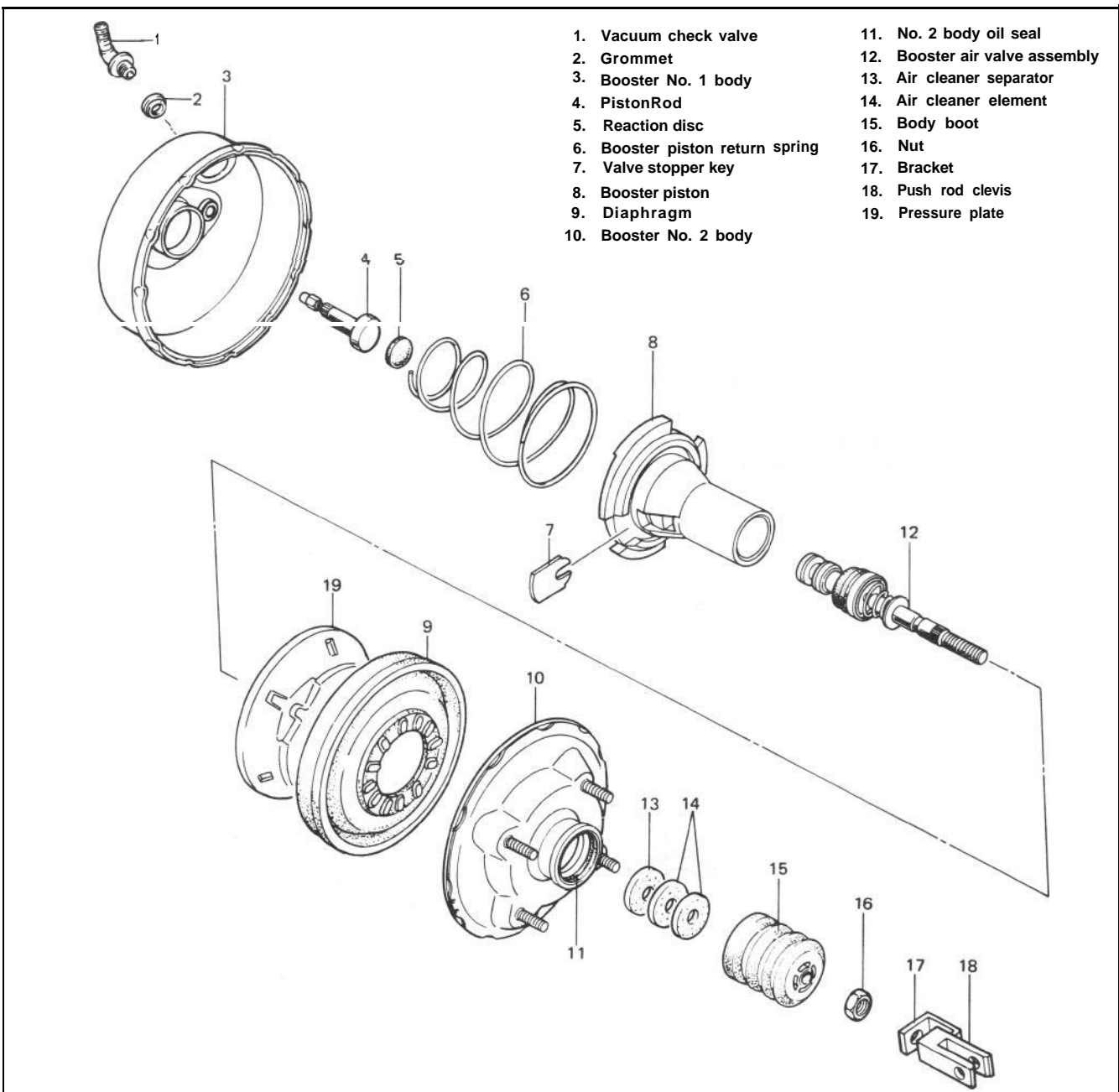
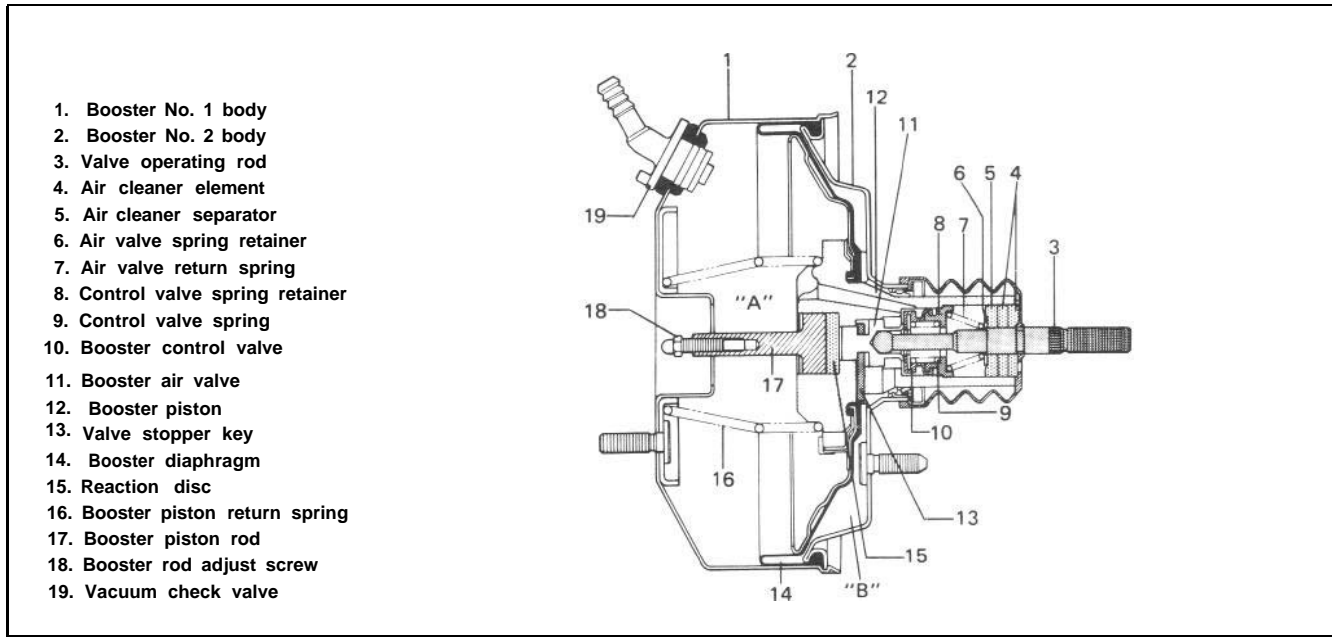


Fig. 19-12

**[Booster OPERATION]**



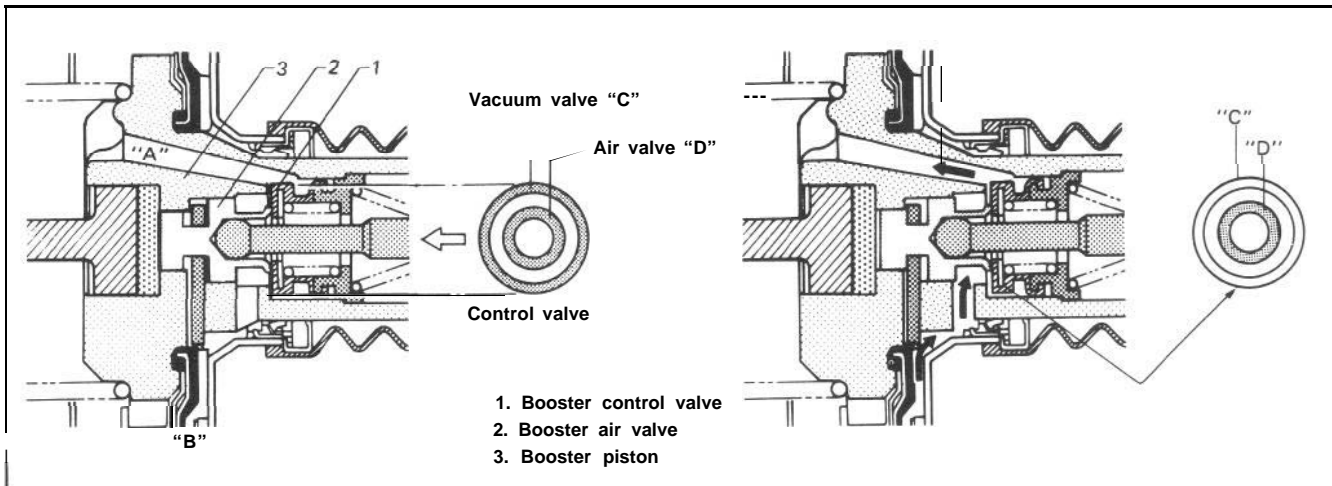
**Fig. 19-13-1 Vacuum Booster Assembly**

When the brake pedal is depressed, the force is transmitted to the piston of the master cylinder through the valve operating rod, booster air valve, reaction disc and piston rod. At the same time, the force of the booster piston developed due to the pressure difference between the two chambers "A" and "B" in the above figure is added to it.

The end of the booster control valve has a double function of a vacuum valve and air valve. That is, as shown in the figure, the booster control valve closes between the "A" and "B" chambers as its outer end "C" contacts the booster piston seat and opens as "C" leaves the booster piston seat (vacuum valve function). Also it closes between the "B" chamber and outside air as its inner end "D" contacts the air valve seat and opens as "D" leaves the air valve seat (air valve function).

**When foot brake pedal is not depressed**

The valve operating rod is pushed to the right by the spring force as shown. The air valve is also enough to the right to contact the valve stopper key as shown. In this state, the vacuum valve (control valve "C") is open and the air valve (control valve "D") is closed. Thus the chambers "A" and "B" conduct and share the same negative pressure (because of no pressure difference) which allows the return spring to push the booster piston to the right.



**Fig. 19-13-2 Vacuum Booster Assembly**

When foot brake pedal is depressed  
 Being pushed by the operating rod, the booster air valve moves to the left as shown. Then the control valve is pushed against the booster piston seat closely by the valve spring force. Thus the vacuum valve (control valve "C") is closed to cut off between the chambers "A" and "B". At this time the air valve (control valve "D") is still closed.

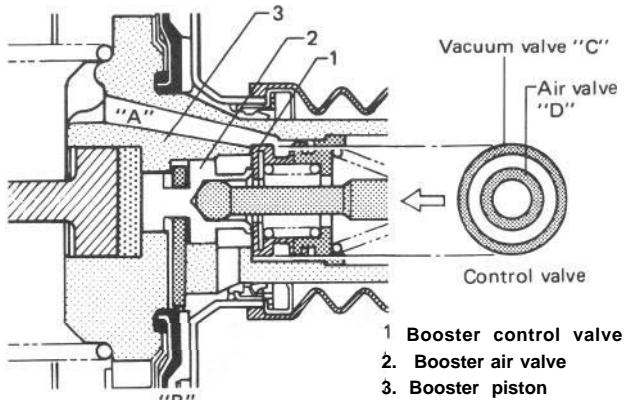


Fig. 19-14-1

As the booster air valve moves further to the left, it leaves the control valve and the air valve (control valve "D") opens to allow the air to flow into the chamber "B". The entry of air causes a difference in pressures between the chambers "A" and "B". When this pressure difference grows greater than the piston return spring force, the booster piston moves to the left and the booster control valve also moves to the left. The resulting air valve (control valve "D") closure stops the air flow into the chamber "B" and its pressure remains as it is. In this way, a small brake pedal depressing force is made into a strong push to the master cylinder push rod to produce high hydraulic pressure.

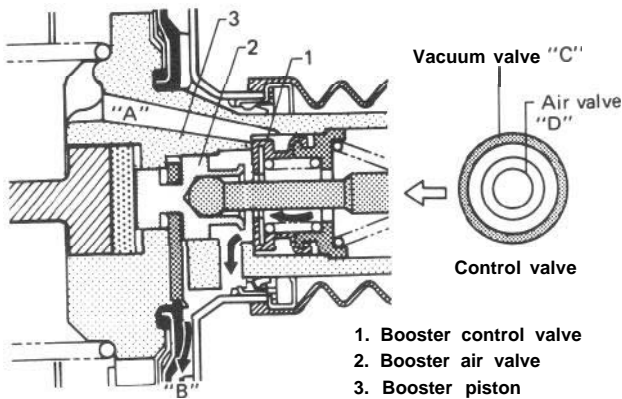


Fig. 19-14-2

When foot brake pedal is released  
 When the brake pedal is released, the booster air valve returns to the right by the master cylinder piston return force and the air valve return spring force as shown. Then the vacuum valve (control valve "C") opens and causes negative pressure in the chamber "B". The result is that the master cylinder piston and booster piston return to their original positions. This is the same state as described under "When foot brake pedal is not depressed".

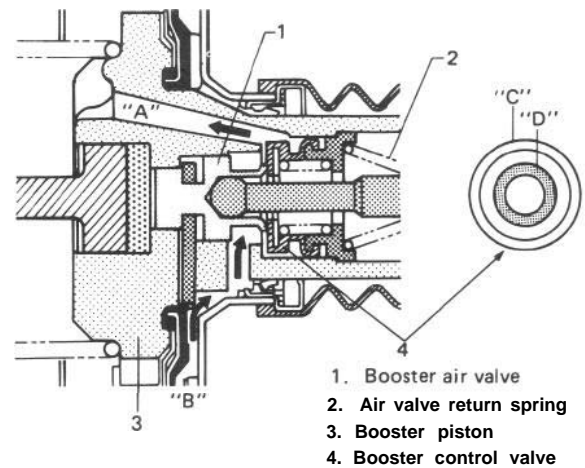


Fig. 19-14-3

Reference

Should any of the vacuum related parts in the booster be faulty, the brake force is not increased. Even then, however, the brake depressing force is transmitted to the valve operating rod, booster air valve, valve stopper key and booster piston in that order, to push the master cylinder push rod. Thus, the braking operation itself will not fail.

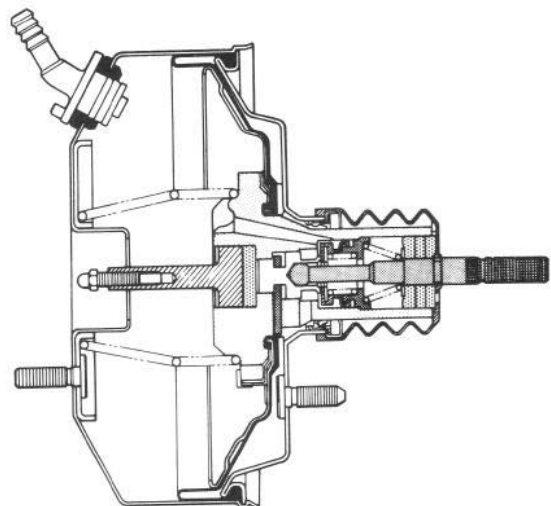


Fig. 19-14-4

## 19-2. FRONT DISC BRAKE

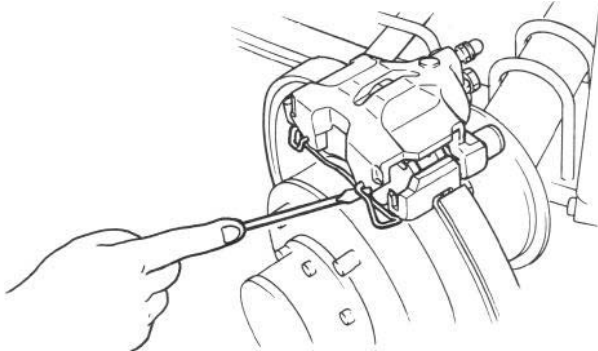
### REMOVAL

- 1) Loosen, but do not remove, front wheel nuts.
- 2) Hoist car.
- 3) Remove wheel nuts and take off front wheels.

### Brake Pad

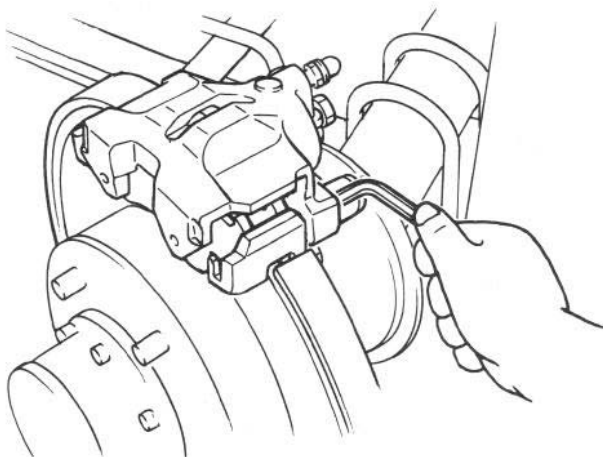
After taking down the wheel, remove brake pads according to the following procedure.

- 1) Remove caliper antirattle clip.



**Fig. 19-17**

- 2) Remove caliper guide pin caps (2 pcs).
- 3) Remove caliper guide pins (2 pcs) by using 6 mm hexagon wrench.



**Fig. 19-18**

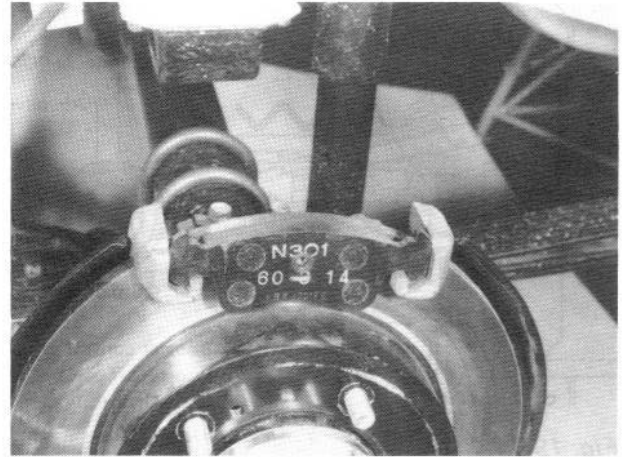
- 4) Remove caliper (cylinder).

### NOTE:

**During removal, be careful not to damage brake flexible hose.**

**Also, don't depress brake pedal.**

- 5) Remove pads.



**Fig. 19-20**



### Caliper

After taking down the wheel, remove piston and piston seal according to the following procedure,

- 1) Clean outside of reservoir.
- 2) Take out fluid with a syringe or such.
- 3) Wipe caliper clean.
- 4) Disconnect brake flexible hose from caliper body (cylinder).

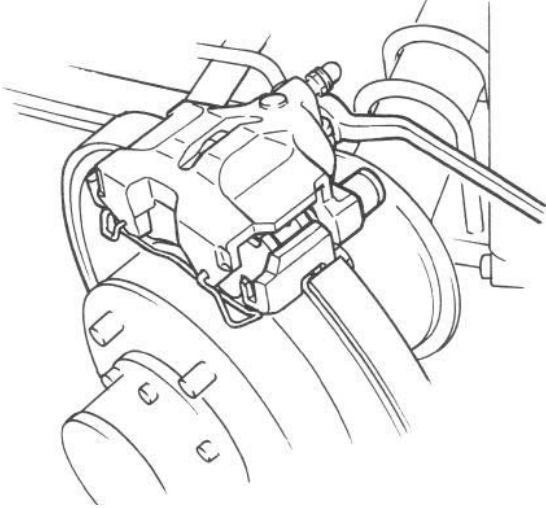


Fig. 19-21

- 5) Remove caliper (cylinder) and bolt. For removal of caliper and pads, refer to steps 1) through 5) of brake pad removal in this section (p. 19-14).

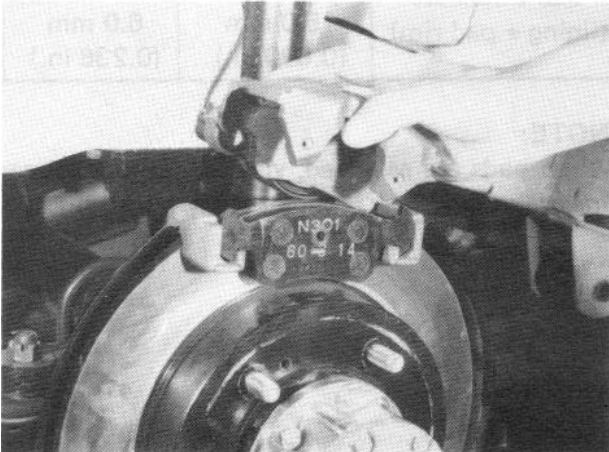


Fig. 19-22

- 6) Blow compressed air into cylinder through bolt hole where flexible hose was fitted. With this air pressure, the piston can be pushed out of cylinder.

#### WARNING:

Do not apply too highly compressed air which will cause piston to jump out of cylinder. It should be taken out gradually with moderately compressed air. Do not place your fingers in front of the piston when using compressed air to push it out

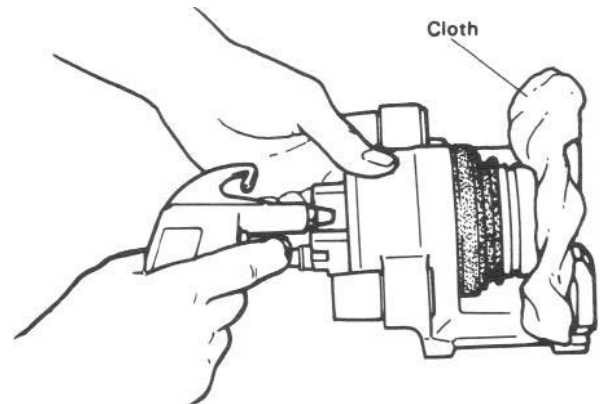


Fig. 19-23

- 7) Remove piston seal using a thin blade like a thickness gauge, etc.

#### CAUTION:

Be careful not to damage inside (bore side) of cylinder.

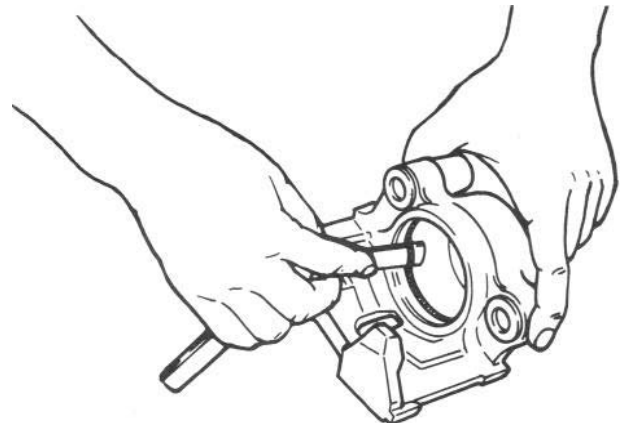
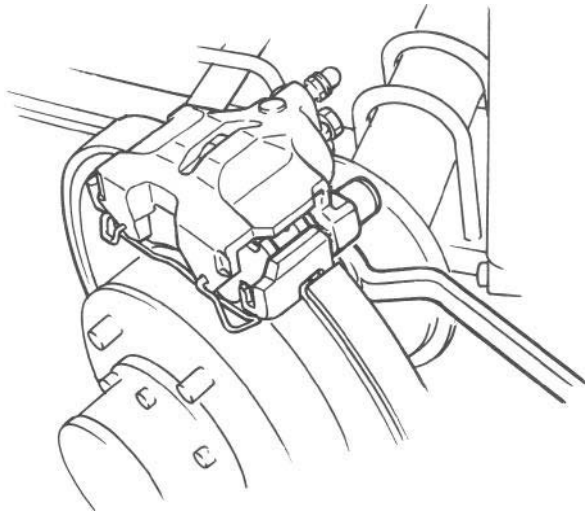


Fig. 19-24

**Disc**

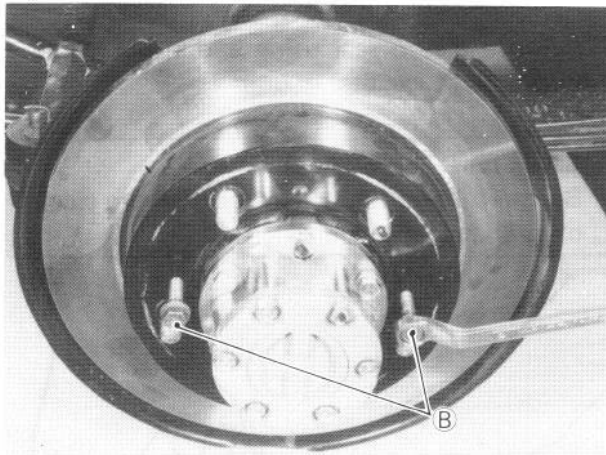
1) After taking down the wheel, remove caliper assembly by loosening carrier bolts (2 pcs).

**CAUTION:**  
During removal, be careful not to damage brake flexible hose and not to depress brake pedal.



**Fig. 19-25**

2) Remove disc by using 8 mm bolts **B** (2 pcs).

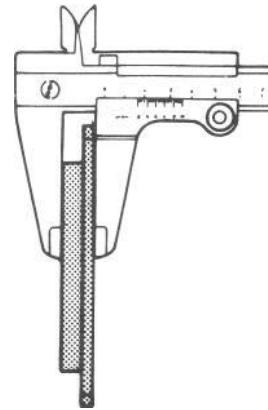


**Fig. 19-26**

**INSPECTION OF COMPONENTS**

**Brake Pad**

Check pad lining for wear. When wear exceeds its limit, replace with a new one.



**Fig. 19-27**

**CAUTION :**  
Never polish pad lining with sandpaper. If lining is polished with sandpaper, hard particles of sandpaper will be deposited in lining and may damage disc. When pad lining requires correction, replace it with a new one.

	Standard	Limit
Pad thickness (lining + pad rim)	15.0 mm (0.590 in.)	6.0 mm (0.236 in.)

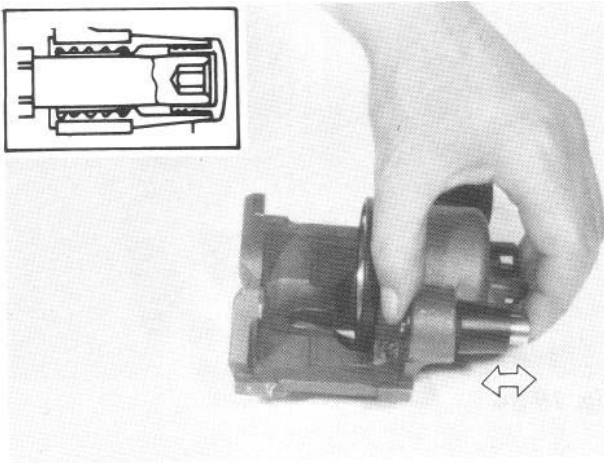
**NOTE:**

When pads are removed, visually inspect caliper for brake fluid leak. Correct leaky point, if any.



**Cylinder Slide Bush**

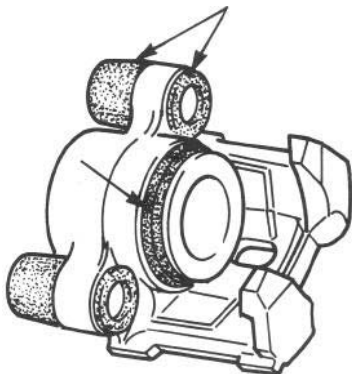
Check bush for smooth movement as shown. If it is found faulty, replace guide pin or guide pin sleeve.



**Fig. 19-28**

**Bush Dust Boot and Cylinder Boot**

Check boots for breakage, crack and damage. If defective, replace.



**Fig. 19-29**

**Piston Seal**

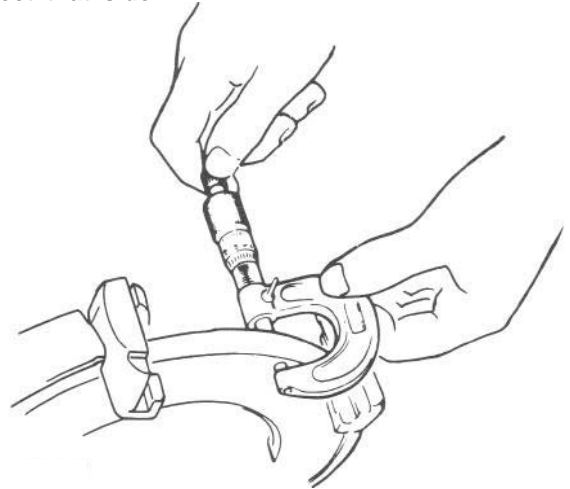
Excessive or uneven wear of pad lining may indicate unsmooth return of the piston. In such a case, replace rubber seal.



**Fig. 19-30**

**Brake Disc**

Check disc surface for scratches in wearing parts. Scratches on disc surface noticed at the time of specified inspection or replacement are normal and the disc is not defective if these are not serious. But when there are deep scratches or scratches all over the surface, replace disc. When only one side is scratched, polish and correct that side.

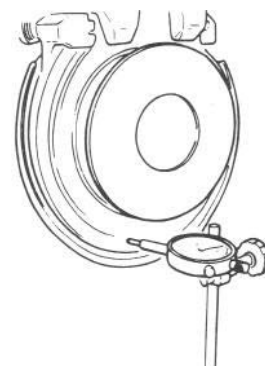


**Fig. 19-31**

	Standard	Limit
Disc thickness	10 mm (0.394 in.)	8.5 mm (0.334 in.)

To check disc deflection, measure at 2 points on its periphery and center with a dial gauge, while rotating the disc.

Limit on disc deflection	0.15 mm (0.006 in.)
--------------------------	---------------------



**Fig. 19-32**

**NOTE:**

Check front wheel bearing for looseness before measurement.

**PRECAUTIONS ON INSTALLATION**

Reassemble front brake in the reverse order of disassembly, using care for the following points.

**CAUTION:**

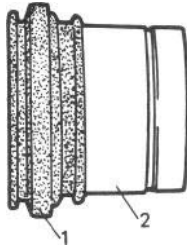
Wash each part cleanly before installation in the same fluid as the one used in master cylinder reservoir.  
Never use other fluid or thinner.  
Before installing piston and piston seal to cylinder, apply fluid to them.  
After reassembling brake line, bleed air from lines.

**Piston Seal**

Piston seal is used to seal piston and cylinder and to adjust clearance between pad and disc. Replace with a new one at every overhaul. Fit piston seal into groove in cylinder taking care not to twist it.

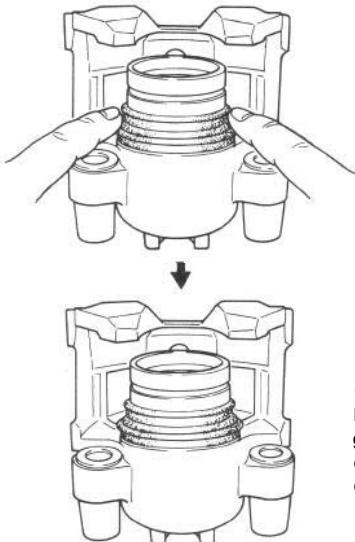
**Piston and Boot**

1) Before inserting piston into cylinder, install boot onto piston as shown below.



- 1. Boot
- 2. Piston

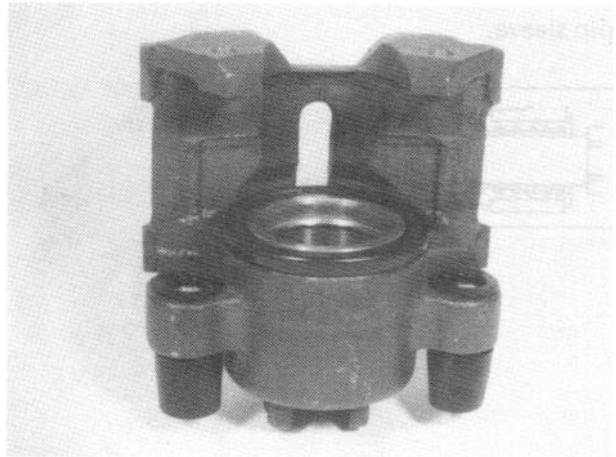
2) Fit boot as it is in the above figure into boot groove in cylinder with fingers.



Check to make sure that boot is fitted into boot groove in cylinder completely in its circumference.

**Fig. 19-33**

3) Insert piston into cylinder by hand and fit boot in- boot groove in piston.



**Fig. 19-34**

4) To confirm that boot is fitted in its groove in cylinder properly, pull piston out of cylinder a little but do not take it all out.

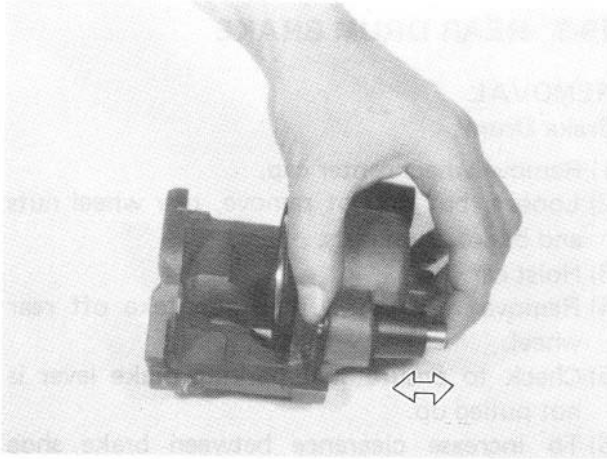


**Fig. 19-35**

5) Insert piston into cylinder by hand.

**Caliper**

Before installing caliper (cylinder body) to carrier, check to ensure that guide pin inserted in each caliper hole can be moved smoothly in thrust direction.



**Fig. 19-36**

**Front Brake Disc and Pad**

Use care not to scratch or put oil or grease on sliding surface of disc and pad during installation work.

After installing brake disc to wheel hub properly, tighten wheel nuts to specified torque.

**Front Wheel Spindle**

Apply SEALING COMPOUND 366E (99000-31090) to mating surfaces of brake caliper holder and steering knuckle.

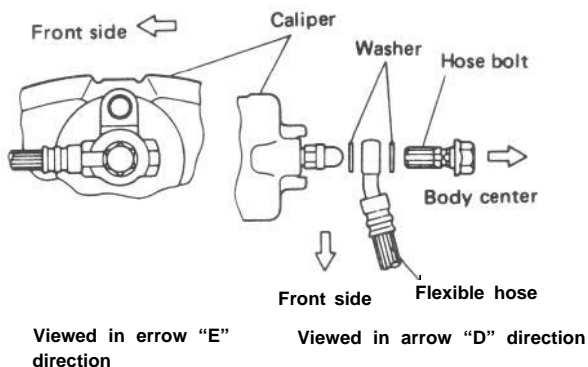
**Dust Cover**

When fitting dust cover onto brake caliper holder, apply SEALING COMPOUND 366E (99000-31090) to mating surfaces of both parts.

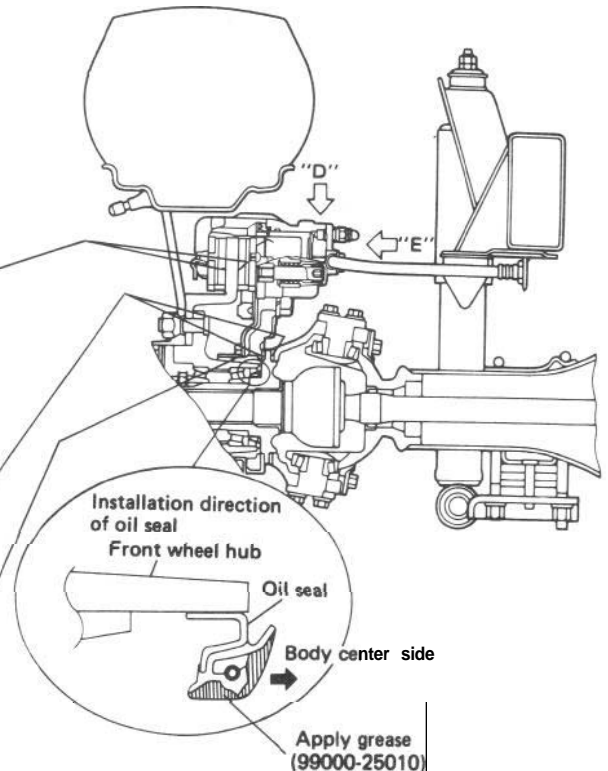
**Front Brake Flexible Hose**

Connect flexible hose to caliper as shown below and tighten hose bolt to specified torque.

Connect the other end of hose to chassis body bracket, being careful not to kink it with front wheels directed straightforward.



**Fig. 19-38**



**Fig. 19-37**

**Tightening torque**

Fastening parts	N-m	kg-m (lb-ft)
Flexible hose bolt	20 - 25	2.0 - 2.5 (14.5 - 18.0)
Carrier bolt	70 -100	7.0- 10.0 (51.0 -72.0)
Caliper holder bolt	40 - 60	4.0- 6.0 (29.0 - 43.0)
Caliper guide pin	25 - 30	2.5 - 3.0 (18.5 - 21.5)
Wheel nut	50 - 80	5.0 - 8.0 (36.5 - 57.5)

**NOTE:**

After completing installation, fill reservoir with brake fluid and bleed brake system. Perform brake test and check each installed part for oil leakage.

### Inspection for Front Brake After installing

Mount tires and make certain that they rotate smoothly, with a force of less than 3.0 kg (6.6 lb).

NOTE:

For the above check, the following must be observed.

- 1) Jack up front wheels, both right and left, off the ground.
- 2) Set free wheeling hubs of both right and left wheels to "LOCK", if equipped.
- 3) Shift transfer shift lever to 2H (rear wheel) position.
- 4) The below figure shows outer periphery of tire.
- 5) Be careful not to depress brake pedal when checking tire for rotation.

If tire rotation is heavy, check the following:

- Wheel bearings for breakage.
- Wheel bearing starting preload for proper adjustment.
- Disc for flatness (Improper flatness brings disc into contact with lining during rotation and makes rotation heavy).

To check this, measure disc deflection.

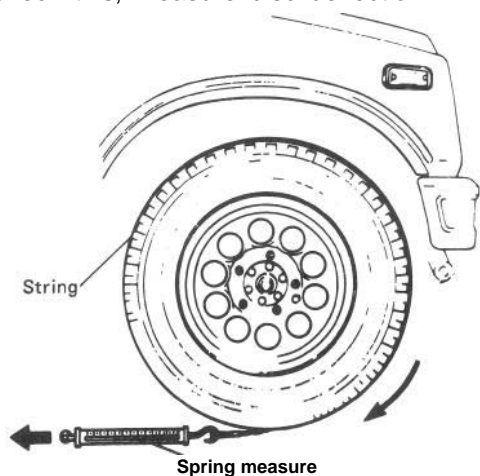


Fig. 19-39

### 19-3. REAR DRUM BRAKE

#### REMOVAL

##### Brake Drums

- 1) Remove wheel center cap.
- 2) Loosen, but do not remove, rear wheel nuts and brake drum nuts.
- 3) Hoist car.
- 4) Remove rear wheel nuts and take off rear wheel.
- 5) Check to ensure that parking brake lever is not pulled up.
- 6) To increase clearance between brake shoe and brake drum, remove parking brake shoe lever return spring @ and disconnect parking brake cable joint ③ from parking brake shoe lever ② ↓

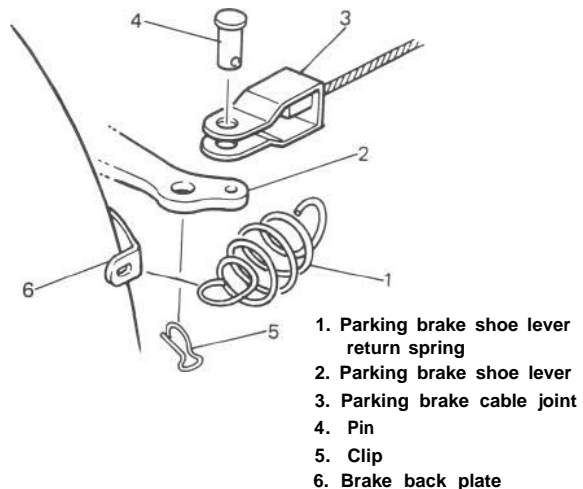


Fig. 19-40

- 7) Remove parking brake shoe lever stopper plate.

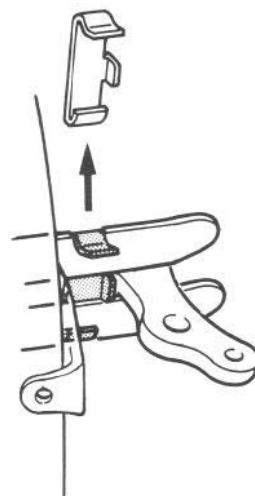
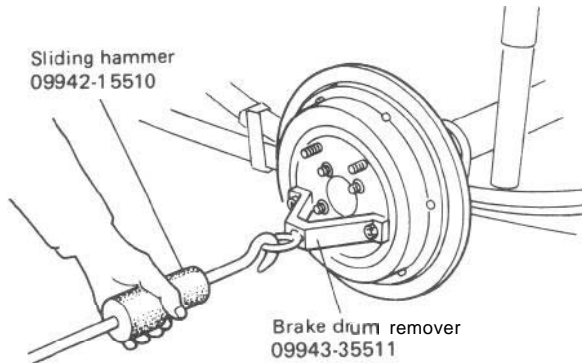


Fig. 19-41



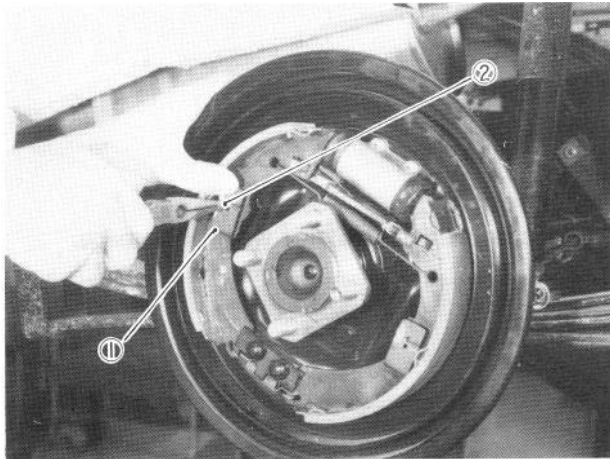
8) Remove brake drum by using special tools.



**Fig. 19-42**

### Brake Shoes and Strut

- 1) Remove brake drum referring to REMOVAL on previous page.
- 2) Remove shoe hold down springs ① by turning shoe hold down pins ② as shown.



**Fig. 19-43**

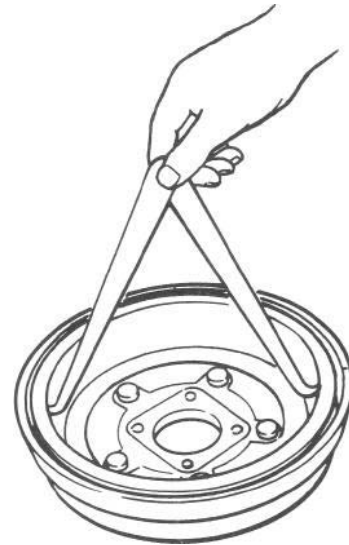
- 3) Remove brake shoes.
- 4) Remove brake shoe strut.

## INSPECTION OF COMPONENTS

### Brake Drum

Inspect drum for cleanliness. Check its braking surface for wear by measuring its inside diameter.

Item	Standard	Service limit
Brake drum ID	220 mm (8.66 in.)	222 mm (8.74 in.)



**Fig. 19-44**

Whenever brake drums are removed, they should be thoroughly cleaned and inspected for cracks, scores, deep grooves.

### Cracked, Scored, or Grooved Drum

A cracked drum is unsafe for further service and must be replaced. Do not attempt to weld a cracked drum. Smooth up any slight scores. Heavy or extensive scoring will cause excessive brake lining wear and it will probably be necessary to resurface drum braking surface.

If brake linings are slightly worn and drum is grooved, drum should be polished with fine emery cloth but should not be cut.

### NOTE:

When drum is removed, visually inspect wheel cylinder for brake fluid leak. Correct leaky point, if any.

### Brake Shoe and Rim

If lining is worn out beyond service limit, replace shoe.

Brake lining	Standard	Service limit
Thickness (lining + shoe rim)	7.0 mm (0.28 in.)	3.0 mm (0.12 in.)

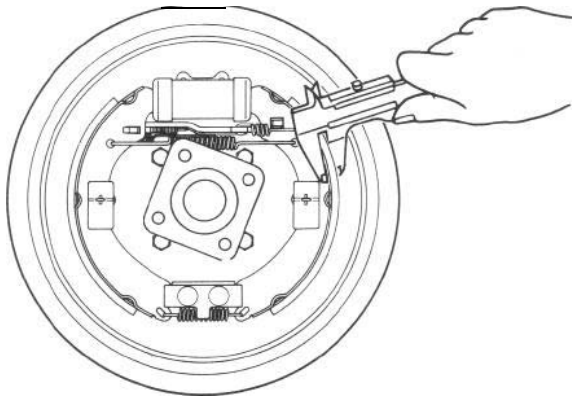


Fig. 19-45

If one of brake linings is worn to or beyond service limit, all linings must be replaced at the same time.

#### NOTE:

Never polish lining with sandpaper. If lining is polished with sandpaper, hard particles of sandpaper will be deposited in lining and may damage drum. When it is required to correct lining, replace it with a new one.

### Wheel Cylinder

When removing brake drum, check wheel cylinder for oil leakage. If any leakage is found, replace wheel cylinder inner parts.

Inspect wheel cylinder disassembled parts for wear, cracks, corrosion or damage.

#### NOTE:

Clean wheel cylinder components with brake fluid.

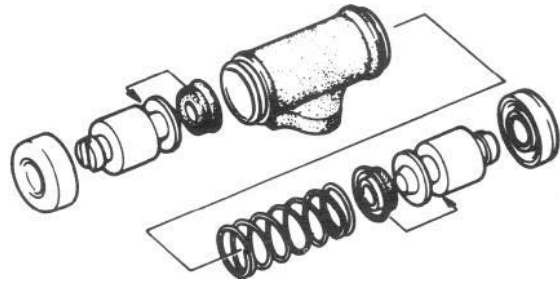


Fig. 19-46

### Brake Strut

Inspect ratchet of strut for wear or damage.

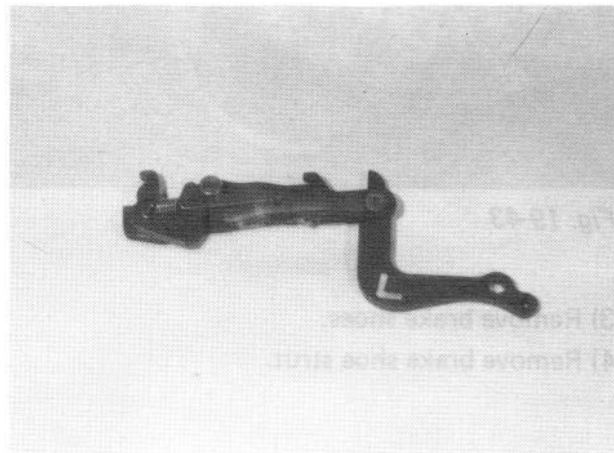
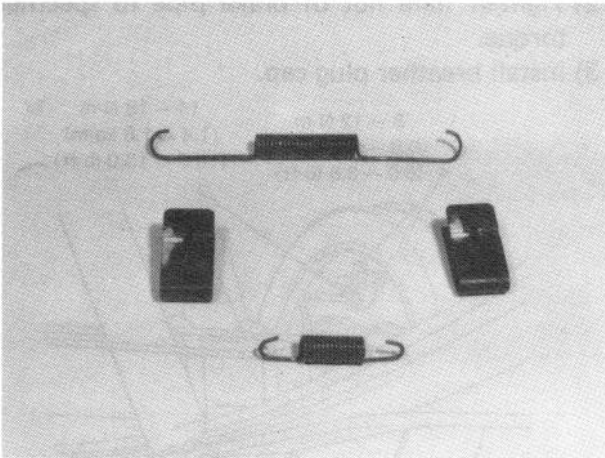


Fig. 19-47

**Springs**

Inspect for damage or weakening. inspect each part for rust. If found defective, replace.



**Fig. 19-48**

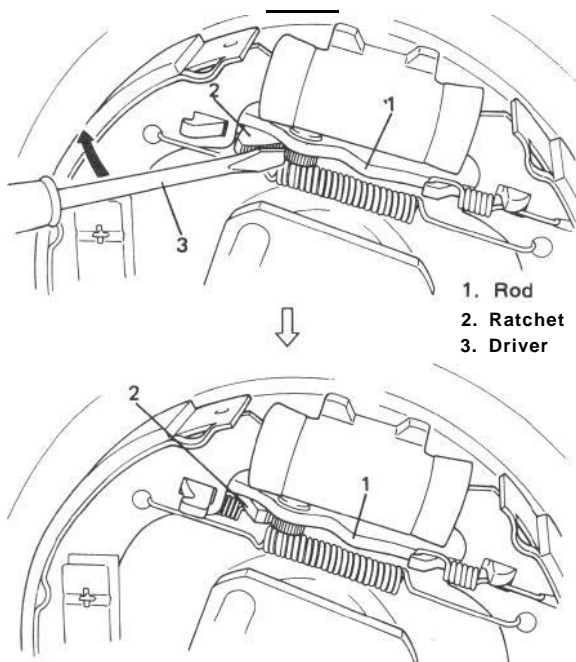
**Self Shoe Clearance Adjusting System**

To check self shoe clearance adjusting system of rear brake for operation, follow steps described below.

- 1) Remove brake drum.

Carry out steps 1) through 8) of brake drum removal (p. 19-20).

- 2) To maximize brake shoe-to-drum clearance, put screw driver between rod and ratchet and push down ratchet as shown in figure.



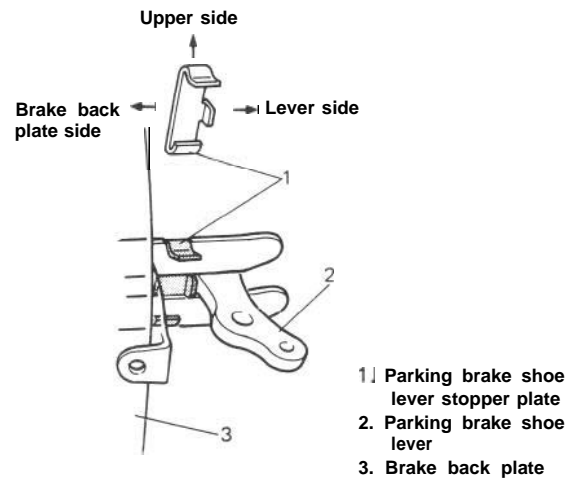
Above figure shows ratchet position where brake shoe-to-drum clearance is maximum.

**Fig. 19-49**

- 3) Install parking brake shoe lever stopper plate.

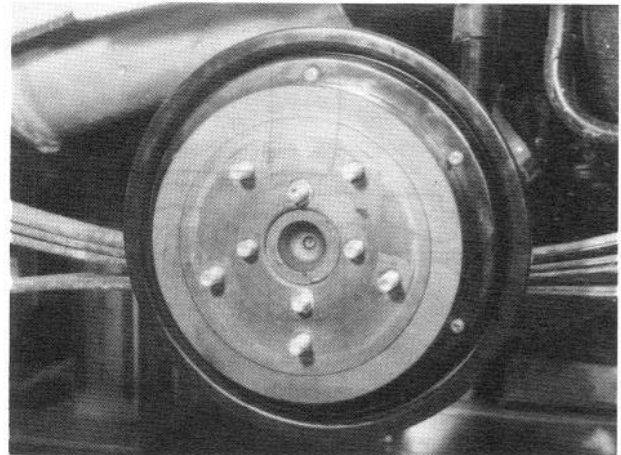
**NOTE:**

Make sure to install this plate.



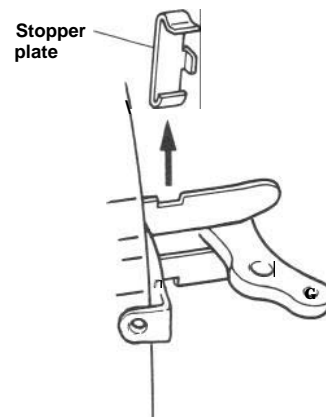
**Fig. 19-49-1**

- 4) Install brake drum and depress brake pedal with about 30 kg (66 lbs) load 4 or 5 times.



**Fig. 19-49-2**

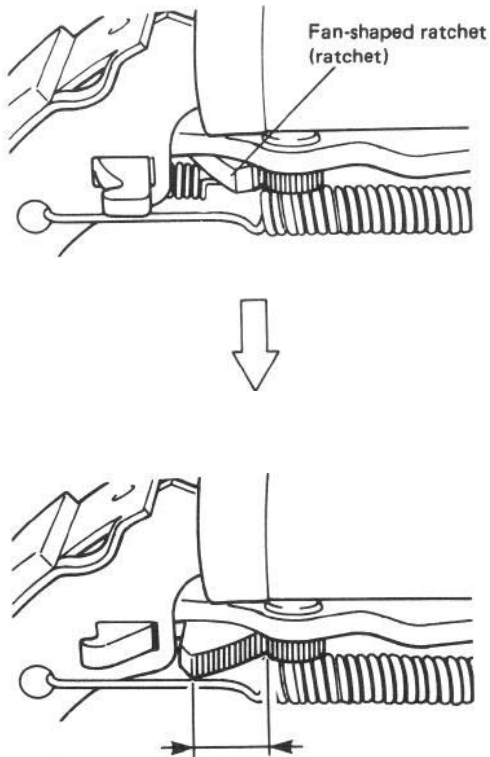
- 5) Remove parking brake shoe lever stopper plate.



**Fig. 19-49-3**

6) Remove brake drum and check fan-shaped ratchet position.

If it has shifted off its previous position in step 2) when it was pushed down, it proves proper operation of shoe adjusting system.



If not, replace strut assembly.

**Fig. 19-49-4**

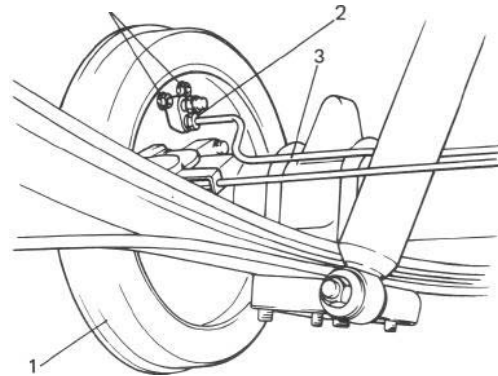
**NOTE:**  
For brake drum installation, refer to steps 1) through 8) of brake drum installation in this section (p. 19-25).

## PRECAUTIONS ON INSTALLATION

### Wheel Cylinder

- 1) Tighten wheel cylinder to brake back plate to specified torque.
- 2) Tighten flare nut of brake pipe to specified torque.
- 3) Install breather plug cap.

8 – 12 N·m (0.8 – 1.2 kg·m) 4, (6.0 – 8.5 lb-ft)	14 – 18 N·m (1.4 – 1.8 kg·m) (10.5 – 13.0 lb-ft)
--	--

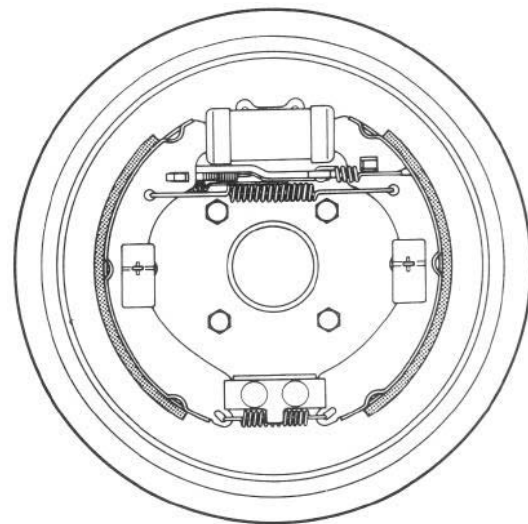


- |                         |                         |
|-------------------------|-------------------------|
| 1. Brake back plate     | 3. Brake pipe           |
| 2. Brake pipe flare nut | 4. Wheel cylinder bolts |

**Fig. 19-50**

### Brake Shoes

- 1) Assemble parts as shown in the reverse order of removal.

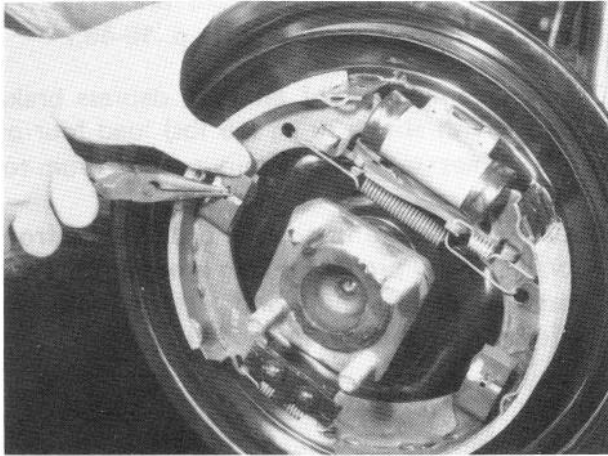


**Fig. 19-50-1**

**NOTE:**  
When installing shoes, use care not to cause damage to wheel cylinder boots.



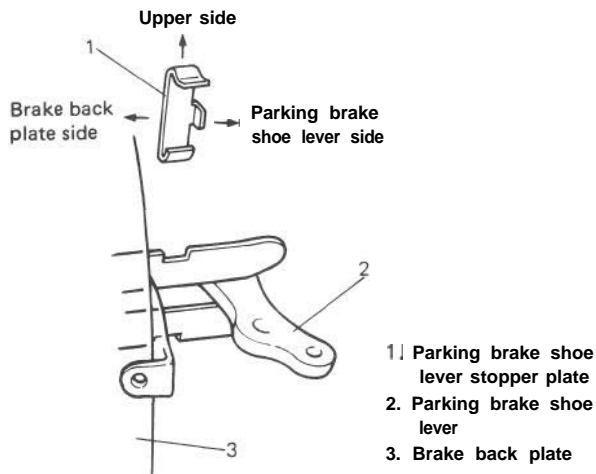
- 2) Install shoe hold down springs by pushing them down in place and turning hold down pins.



**Fig. 19-51**

**Brake Drum**

- 1) Install parking brake shoe lever stopper plate, referring to the following figure for its installation direction.



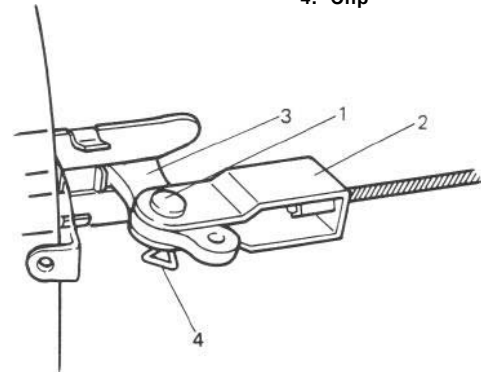
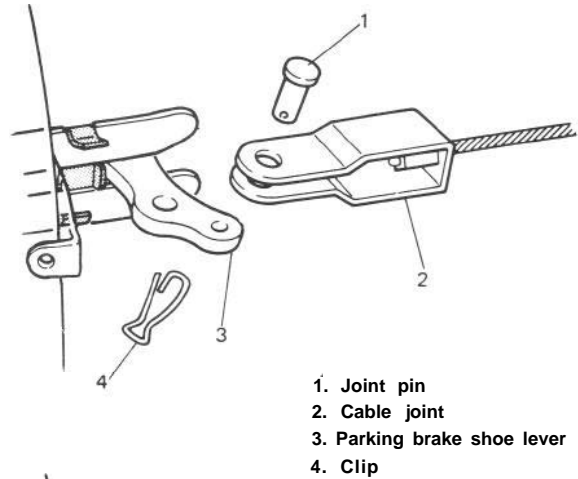
**Fig. 19-52**

1. Parking brake shoe lever stopper Plate

- 2) Connect brake cable joint to parking brake shoe lever by using joint pin. Insert joint pin down from the top and install clip into joint pin hole securely.

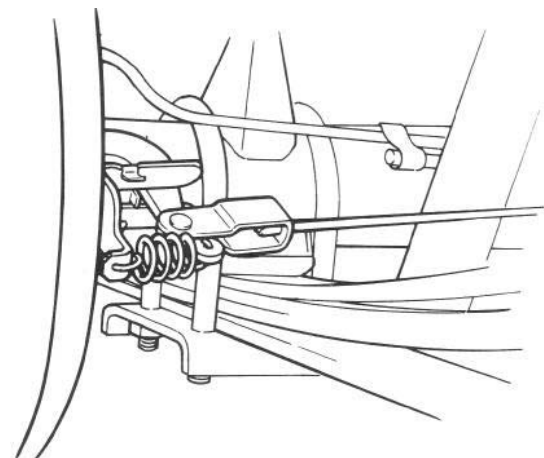
**NOTE:**

Check to ensure that clip is in good condition before installing it. If deformed or broken, replace.



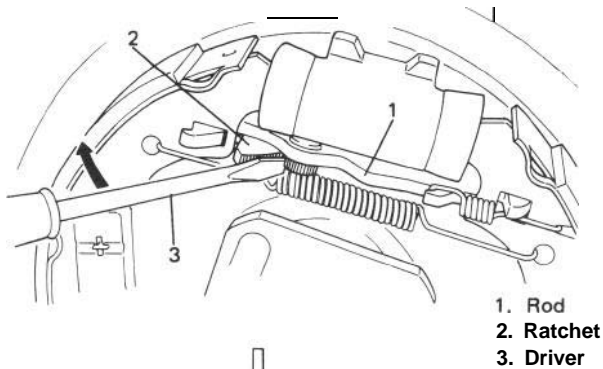
**Fig. 19-52-1**

- 3) Install parking brake shoe lever return spring.

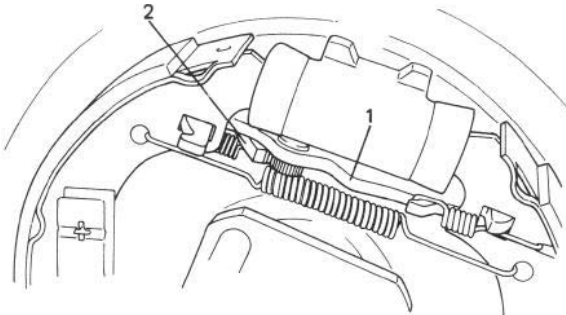


**Fig. 19-53**

- 4) Before installing brake drum, to maximize brake shoe-to-drum clearance, put screw driver between rod and ratchet and push down ratchet as shown in figure.

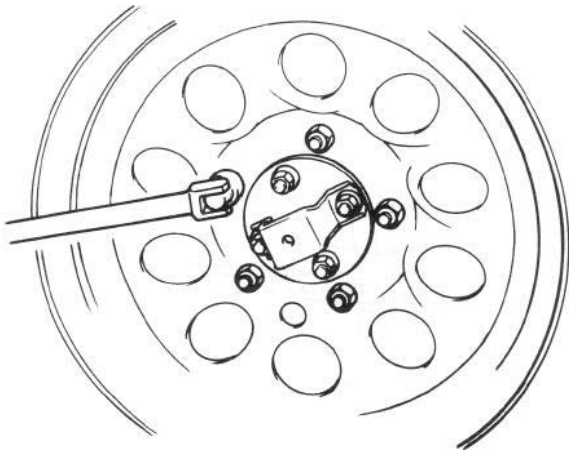


Below figure shows ratchet position where brake shoe-to-drum clearance is maximum.



**Fig. 19-54**

- 5) Install brake drum after making sure that inside of brake drum and brake shoes are free from dirt and oil.
- 6) Torque wheel nuts and brake drum nuts to specification.



**Fig. 19-55**

**NOTE:**

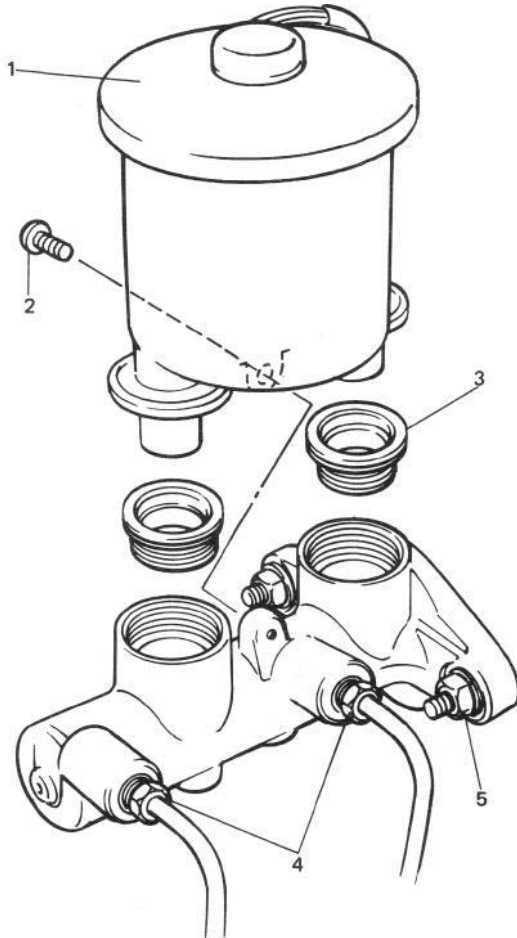
If brake backing plate was removed from wheel cylinder or brake pipe was disconnected from wheel cylinder. Bleed air from brake system. (For bleeding operation, refer to p. 19-46.)

- 7) Upon completion of all jobs, depress brake pedal with about 30 kg (66 lbs) load four or five times so as to obtain proper drum-to-shoe clearance.
- 8) Check to ensure that brake drum is free from dragging and proper braking is obtained. Then remove car from hoist and perform brake test (foot brake and parking brake).

## 19-4. MASTER CYLINDER

### REMOVAL

- 1) Clean outside of reservoir.
- 2) Take out fluid with a syringe or such.
- 3) Remove reservoir connector screw.
- 4) Remove reservoir.



1. Reservoir
2. Connector screw
3. Grommets
4. Flare nuts
5. Attaching nuts

**Fig. 19-56**

- 5) Disconnect 2 brake pipes from master cylinder.

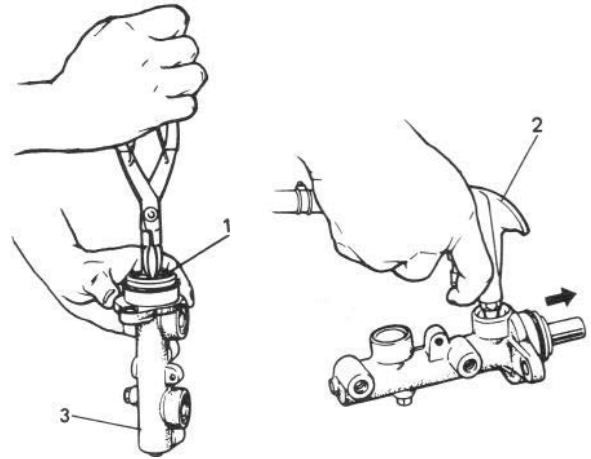
### NOTE:

Do not allow brake fluid to get on painted surfaces.

- 6) Remove 2 attaching nuts and washers.
- 7) Remove master cylinder.

### DISASSEMBLY

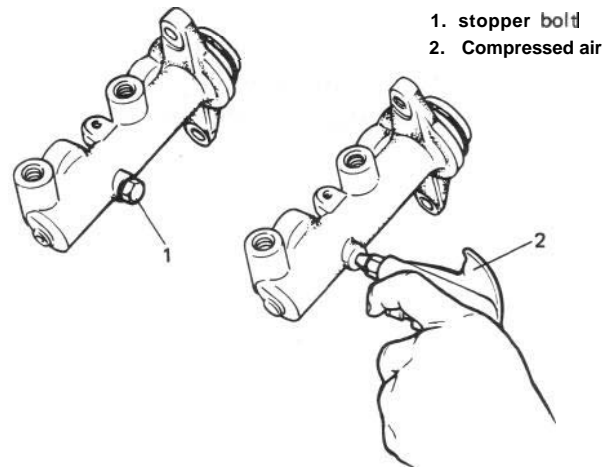
- 1) Remove circlip.
- 2) Remove primary piston by using compressed air as shown. Be cautious during removal as primary piston will jump out.



1. Circlip
2. Compressed air
3. Master cylinder

**Fig. 19-57**

- 3) Remove piston stopper bolt. Then remove secondary piston by blowing compressed air into hole from which piston stopper bolt was removed.



1. stopper bolt
2. Compressed air

**Fig. 19-58**

## INSPECTION OF COMPONENTS

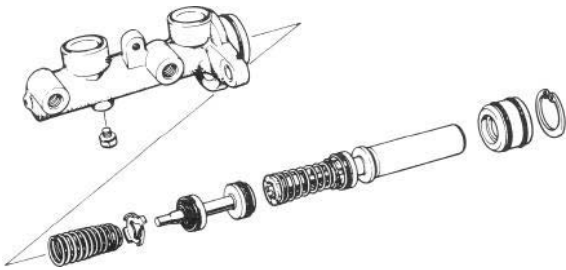
### Master Cylinder Inner Parts

Inspect all disassembled parts for wear or damage, and replace parts if necessary.

#### NOTE:

Wash disassembled parts with brake fluid.

Do not reuse piston cups.



**Fig. 19-59**

Inspect master cylinder bore for scoring or corrosion. It is best to replace a corroded cylinder. Corrosion can be identified as pits or excessive roughness.

#### NOTE:

**Polishing bore of master cylinder with cast aluminum body with anything abrasive is prohibited, as damage to cylinder bore may occur.**

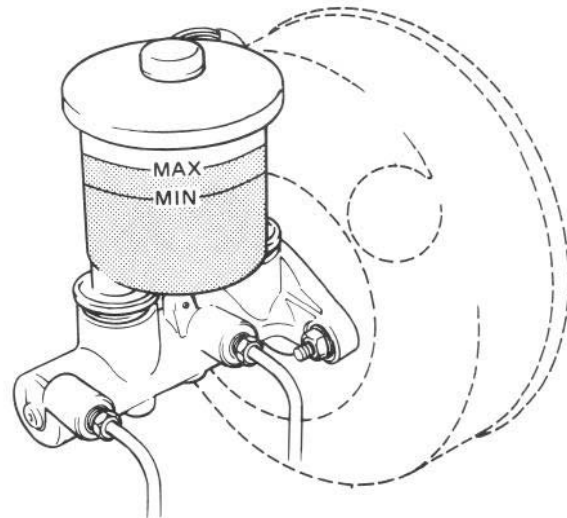
Rinse cylinder in clean brake fluid. Shake excess rinsing fluid from cylinder. Do not use a cloth to dry cylinder, as lint from cloth will remain on cylinder bore surface.

## Reservoir

#### NOTE:

**Do not use shock absorber fluid or any other fluid which contains mineral oil. Do not use a container which has been used for mineral oil or a container which is wet from water. Mineral oil will cause swelling and distortion of rubber parts in the hydraulic brake system and water will mix with brake fluid, lowering the fluid boiling point. Keep all fluid containers capped to prevent contamination.**

Fluid to fill reservoir with is indicated on reservoir cap of the car with embossed letters or in owner's manual supplied with the car. Add fluid up to MAX line.



**Fig. 19-60**

## ASSEMBLY

### NOTE:

Before assembling, wash each part in fluid recommended to use for the car.

- 1) Assemble secondary piston as shown below.

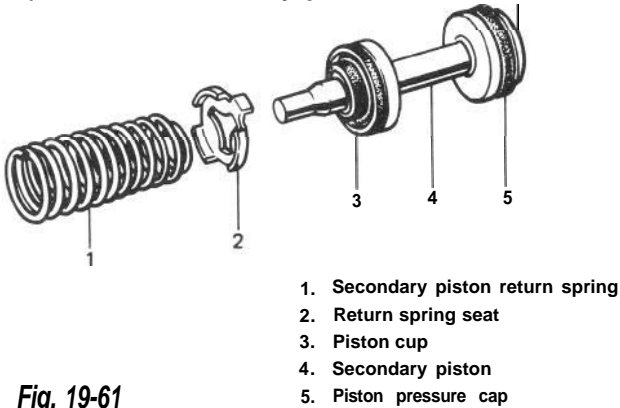


Fig. 19-61

- 2) Install secondary piston assembly into cylinder.
- 3) Install primary piston in cylinder.
- 4) Depress, and install circlip.

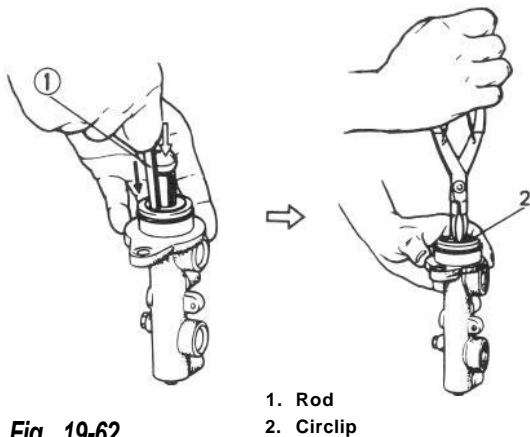


Fig. 19-62

- 5) Install piston stopper bolt with pistons pushed in all the way and tighten it to specified torque.

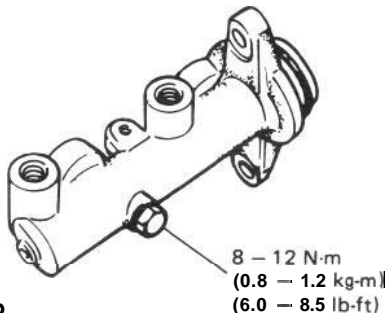


Fig. 19-63

- 6) For installation on car, refer to INSTALLATION.

## PRECAUTION OF INSTALLATION

### NOTE:

See NOTE at the beginning of this section.

Adjust clearance between booster piston rod and primary piston with special tool (See page 19-33).

- 1) Install master cylinder as shown and torque attaching nuts to specification.
- 2) Connect 2 hydraulic lines and torque flare nuts to specification.
- 3) When using new grommets, lubricate them with the same fluid as the one to fill reservoir with. Then press-fit grommets to master cylinder. Grommets must be seated in place.
- 4) Install reservoir and tighten screw to specified torque.
- 5) Fill reservoir with specified fluid.

After installing, check brake pedal height, bleed air from system (See p. 19-43 and p. 19-46) and also check for fluid leakage.

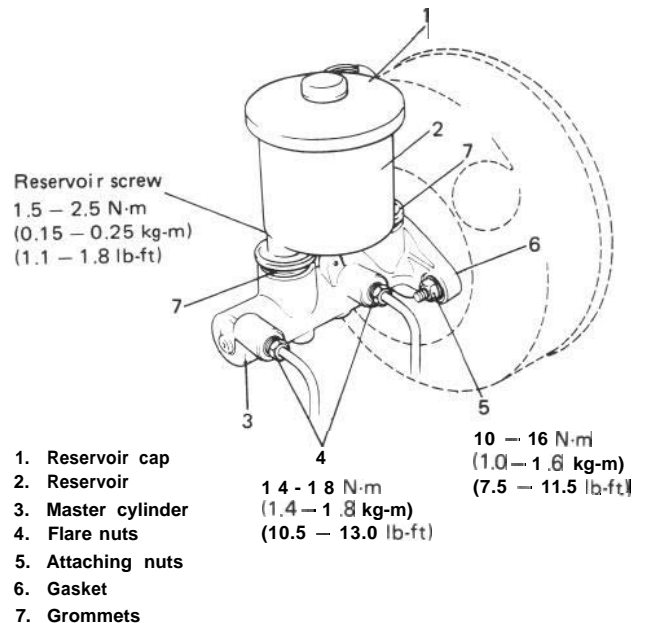
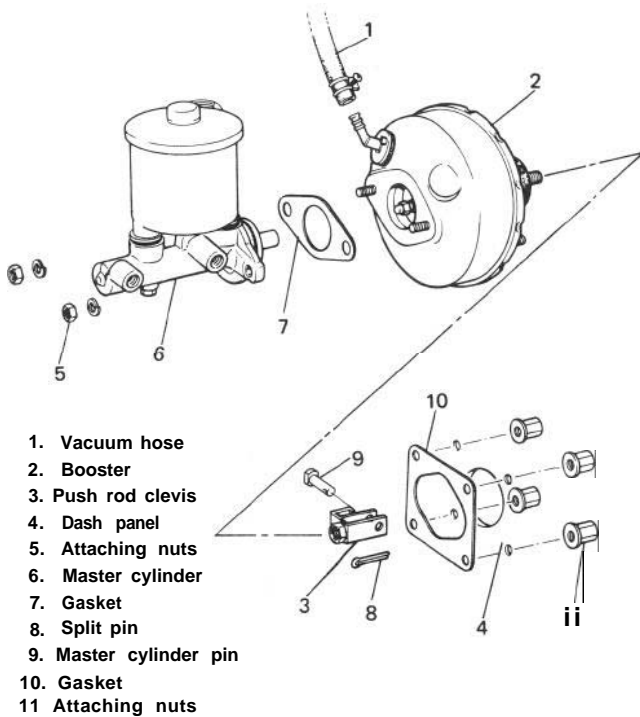


Fig. 19-64

## 19-5. BRAKE BOOSTER

### REMOVAL

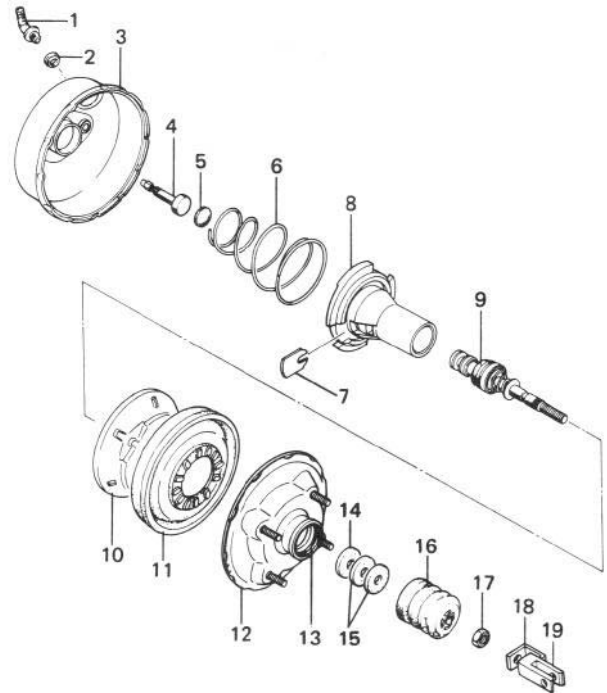
- 1) Take out fluid from master cylinder with a syringe or such.
- 2) Disconnect 2 brake pipes from master cylinder and remove master cylinder from booster.
- 3) Disconnect vacuum hose from booster.
- 4) Disconnect push rod clevis from brake pedal arm.
- 5) Remove attaching nuts and then booster as shown.



1. Vacuum hose
2. Booster
3. Push rod clevis
4. Dash panel
5. Attaching nuts
6. Master cylinder
7. Gasket
8. Split pin
9. Master cylinder pin
10. Gasket
11. Attaching nuts

**Fig. 19-65**

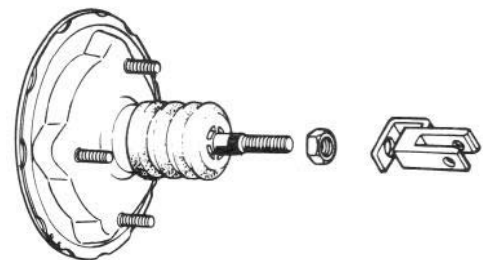
### DISASSEMBLY



- |                                 |                           |
|---------------------------------|---------------------------|
| 1. Vacuum check valve           | 11. Diaphragm             |
| 2. Grommet                      | 12. Booster No. 2 body    |
| 3. Booster No. 1 body           | 13. No. 2 body oil seal   |
| 4. Piston rod                   | 14. Air cleaner separator |
| 5. Reaction disc                | 15. Air cleaner element   |
| 6. Booster piston return spring | 16. Body boot             |
| 7. Valve stopper key            | 17. Nut                   |
| 8. Booster piston               | 18. Bracket               |
| 9. Booster air valve assembly   | 19. Push rod clevis       |
| 10. Pressure plate              |                           |

**Fig. 19-66**

- 1) Remove piston rod from booster.
- 2) Remove push rod clevis and nut.



**Fig. 19-67**



3) Set booster to special tool (A) as shown.

**NOTE:**

When setting, check to be sure that booster vacuum check valve is not in faulty contact with base of special tool.

Tighten 2 nuts on upper part of special tool evenly to specified torque.

Special tool nuts tightening torque	N·m	kg-m	lb-ft
	3 - 5	0.3 - 0.5	2.2 - 3.6

**NOTE:**

Be careful not to over-tighten nuts, or booster body will be deformed.

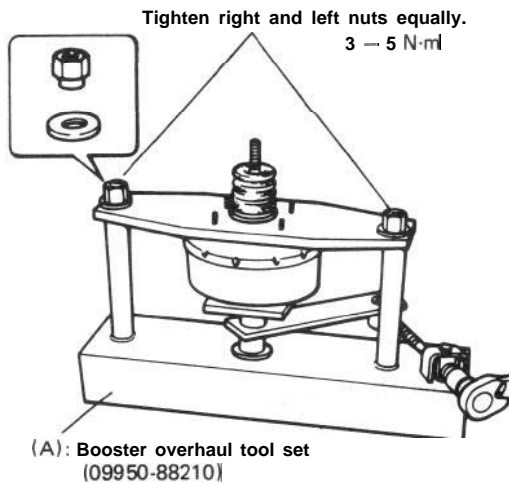


Fig. 19-68

4) Turn special tool bolt clockwise until No. 1 body projecting part and No. 2 body depressed part fit each other.

Once they are matched, make match marking on No. 1 and No. 2 bodies to facilitate their installation.

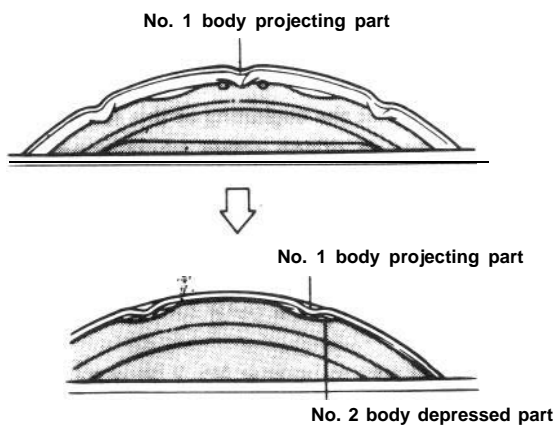


Fig. 19-69

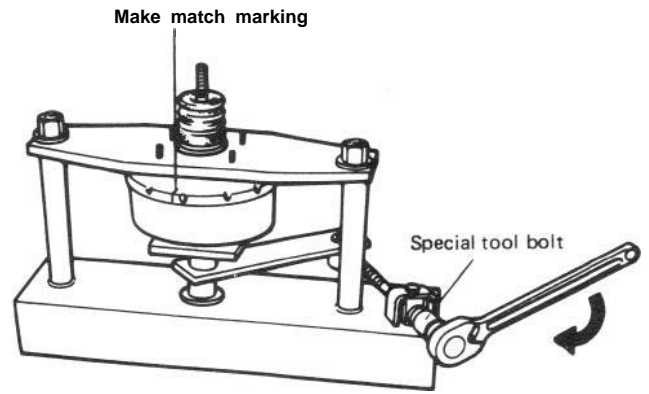


Fig. 19-70

5) Remove booster from special tool and separate No. 1 body and No. 2 body. Remove piston return spring.

**NOTE:**

When separating two bodies, hold both bodies carefully to prevent either body from jumping off by spring force.

6) From booster No. 2 body, remove boot, air cleaner elements and air cleaner separator in this order.

7) Using camshaft pulley holder (special tool 09917-68210), turn booster piston counter-clockwise and remove piston.

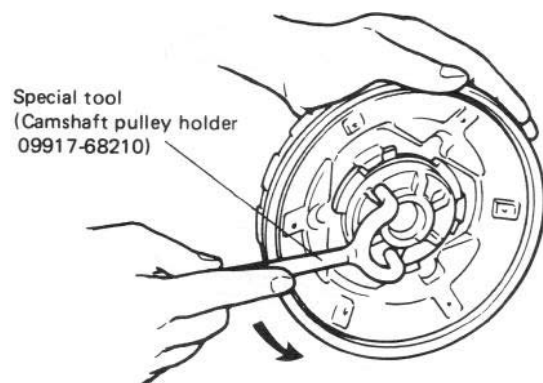
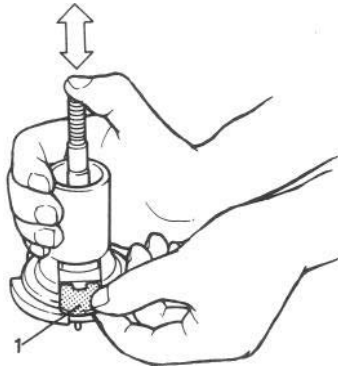


Fig. 19-71

8) While compressing air valve spring (by moving rod up and down as shown), remove valve stopper key. Then remove booster air valve assembly from booster piston.

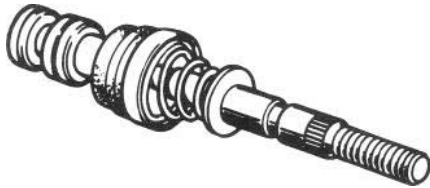
**NOTE:**

Booster air valve assembly can't be disassembled.



1) Valve stopper key

Booster air valve assembly

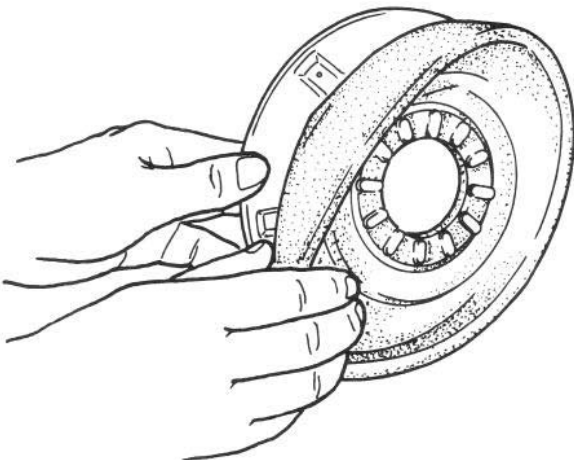


**Fig. 19-72**

9) Remove diaphragm from pressure plate.

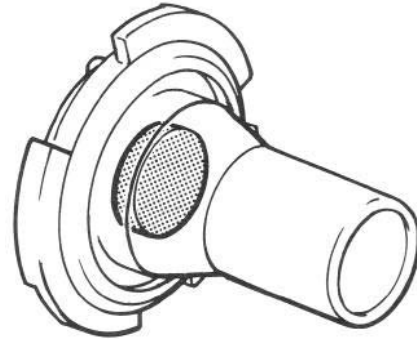
**NOTE:**

Don't use screwdriver or any other tool for removal. Pull it off by hand carefully handling pressure plate groove area where diaphragm is fitted.



**Fig. 19-73**

10) Remove reaction disc from booster piston with fingers.

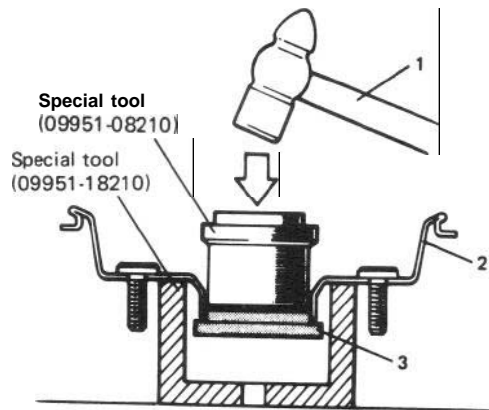


**Fig. 19-74**

11) Remove oil seal from booster No. 2 body with special tools as shown.

**NOTE:**

Removed oil seal must not be reused.



- 1. Hammer lightly
- 2. No. 2 body
- 3. Oil seal

**Fig. 19-75**



## INSPECTION

### Inner Parts

#### NOTE:

After disassembly, soak all metal parts in ethyl alcohol. Wipe rubber diaphragm and plastic parts with a clean cloth. Use ethyl alcohol damped cloth to wipe out heavy dirt. Application of much ethyl alcohol especially to rubber parts is prohibited.

[Rubber parts]

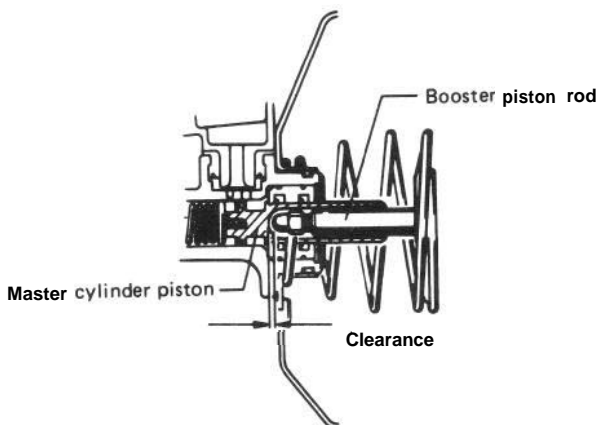
Wipe fluid from rubber parts and carefully inspect each rubber part for cuts, nicks or other damage. These parts are the key to the control of air flow. If there is any question as to the serviceability of rubber parts, REPLACE them.

[Metal parts]

BADLY DAMAGED ITEMS, OR THOSE WHICH WOULD TAKE EXTENSIVE WORK OR TIME TO REPAIR, SHOULD BE REPLACED. IN CASE OF DOUBT, INSTALL NEW PARTS.

#### Inspection/Adjustment of Clearance Between Booster Piston Rod and Master Cylinder Piston

The length of booster piston rod is adjusted to provide specified clearance between piston rod end and master cylinder piston.



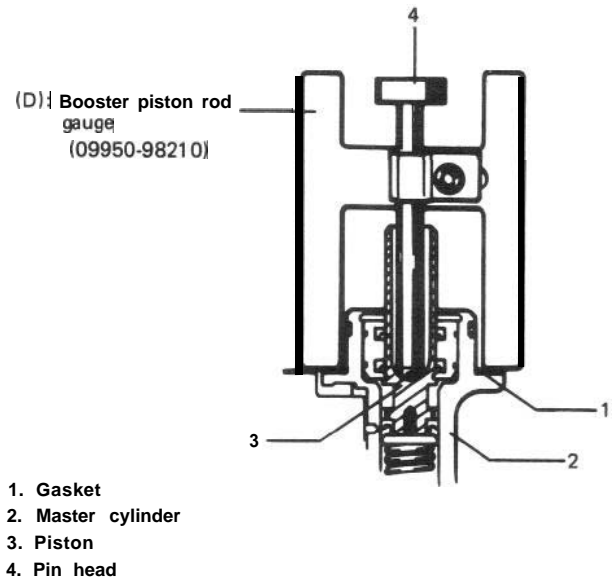
**Fig. 19-76**

Before measuring clearance, push piston rod several times so as to make sure reaction disc is in place.

Take measurement with gasket installed to master cylinder.

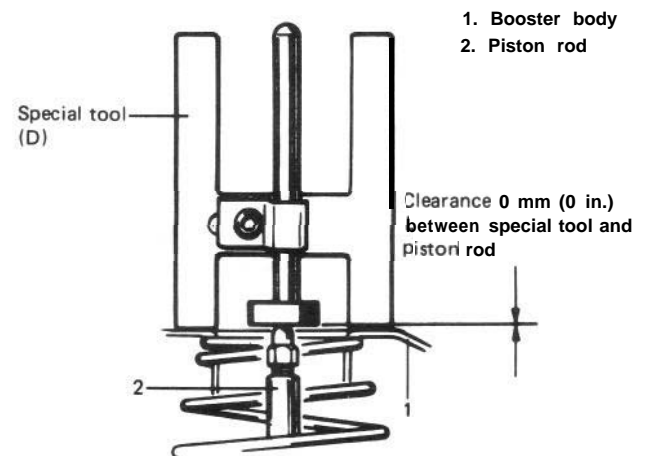
Keep inside of booster at atmospheric pressure for **measurement**.

- 1) Set special tool (D) on master cylinder and push pin until it contacts piston.



**Fig. 19-77**

- 2) Turn special tool upside down and place it on booster. Adjust booster piston rod length until rod end contacts pin head.
- 3) Adjust clearance by turning adjusting bolt of piston rod.



**Fig. 19-78**

#### Reference

When adjusted as above, if negative pressure is applied to booster with engine at idle, piston to piston rod clearance should become 0.1 – 0.5 mm (0.004 – 0.020 in.).

## BOOSTER INSPECTION TABLE

Part	Inspect For	Corrective Action
1. Booster piston	Cracks, distortion or damage.	Replace.
2. Air valve ass'y (Control valve spring)	Damaged or worn seal surfaces.	Replace.
3. Reaction disc	Damage or wear.	Replace.
4. Diaphragm and boot	Damage.	Replace.
5. Piston rod	Damage or bend.	Replace.
6. Booster No. 1 & No. 2 body.	<ol style="list-style-type: none"> <li>Scratches, scores, pits, dents, or other damage affecting rolling or sealing of diaphragm or other seals.</li> <li>Cracks, damage at ears, damaged threads on studs.</li> <li>Bent or nicked locking lugs.</li> <li>Loose studs.</li> </ol>	<p>Replace, unless easily repaired.</p> <p>Replace, unless easily repaired.</p> <p>Replace, unless easily repaired.</p> <p>Replace.</p>
7. Air filters and separator	Dirt.	Replace.

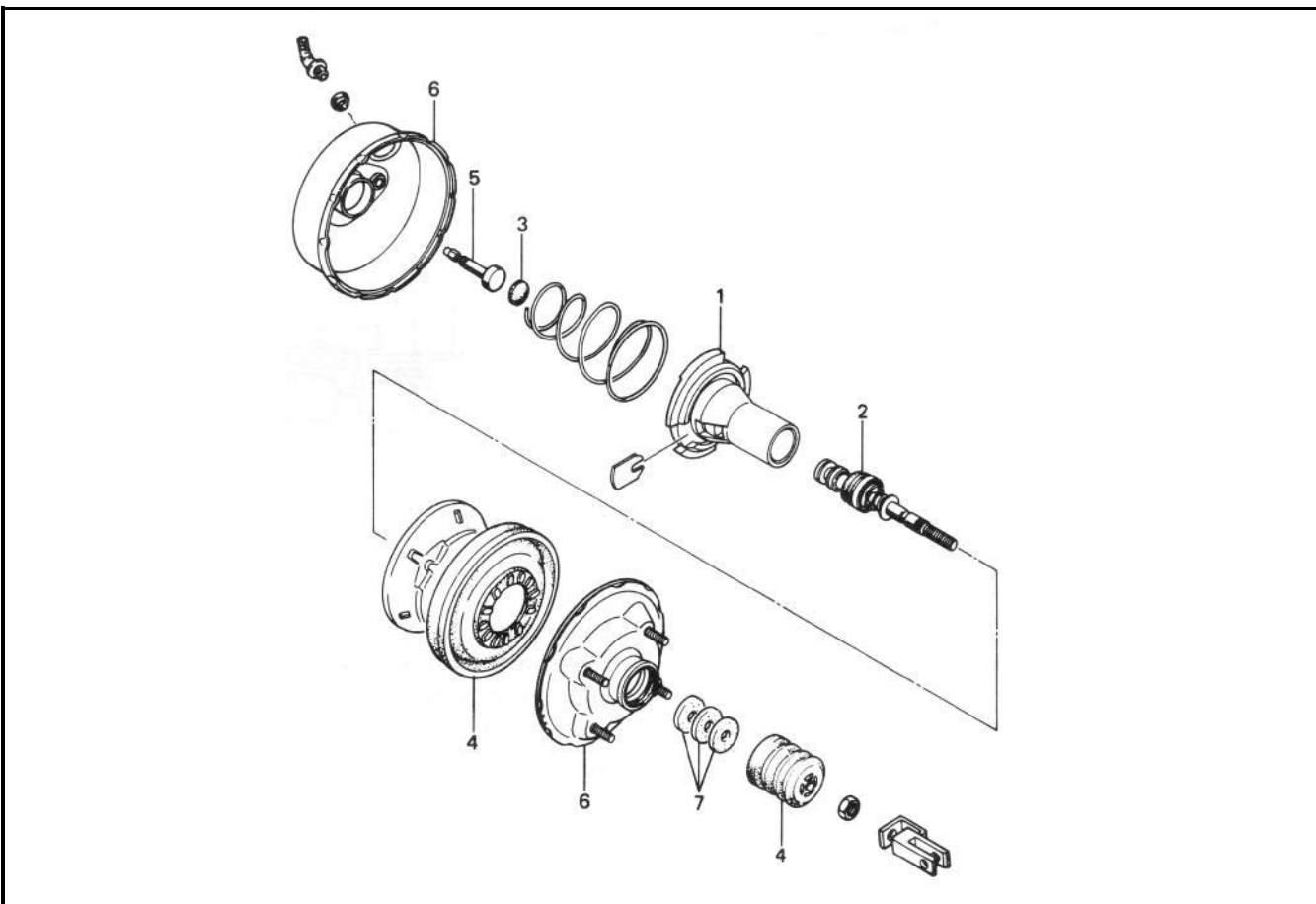


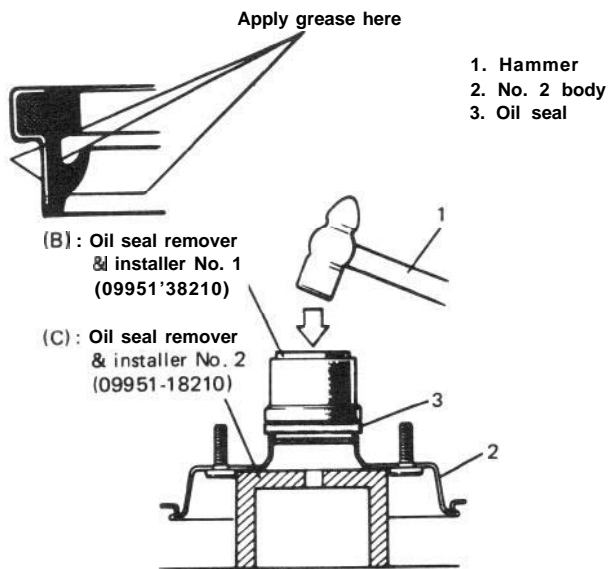
Fig. 19-79

**ASSEMBLY**

**NOTE:**

See NOTE at the beginning of this section.  
 Be sure to use silicon grease wherever application of grease is instructed during assembly.  
 Use of oil and grease for installation of check valve and its grommet is strictly prohibited.

- 1) Apply grease to oil seal outer surface and oil seal lip as shown.  
 Press-fit oil seal to booster No. 2 body by using special tool (B) and (C).



**Fig. 19-80**

- 2) Install booster air valve assembly to booster piston. Before installation, apply grease as shown.



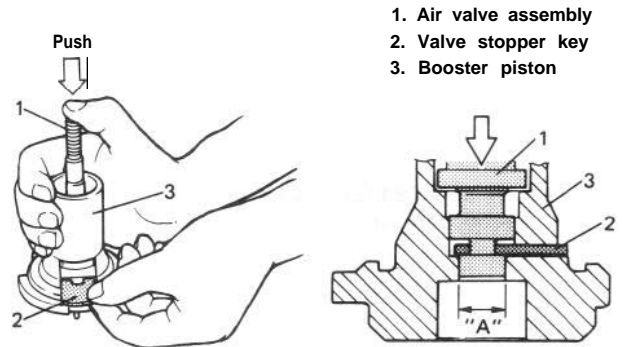
Sliding surface against piston (sealed surface)

**Fig. 19-81**

- 3) Compress air valve assembly and insert valve stopper key.

**NOTE:**

Be sure that valve assembly is in piston "A" as indicated in figure. (Don't force installation.)

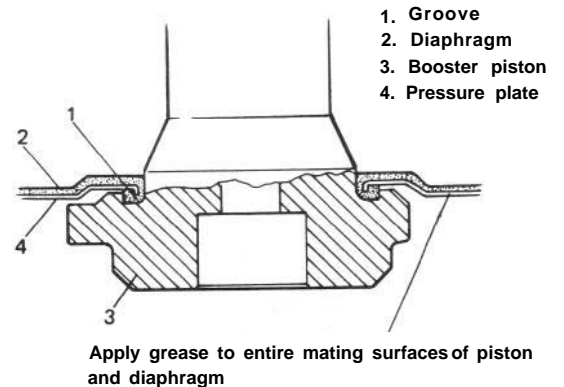


**Fig. 19-82**

- 4) Install diaphragm to pressure plate by hand.

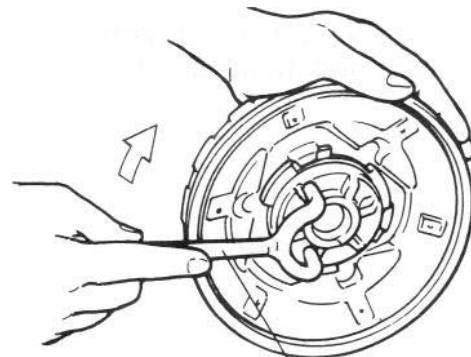
**NOTE:**

Check to be sure that diaphragm is seated securely in pressure plate groove for diaphragm by turning diaphragm.



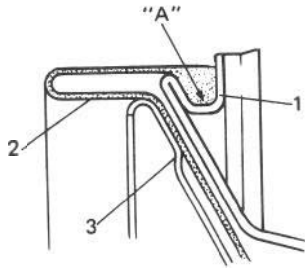
**Fig. 19-83**

- 5) Install reaction disc to booster piston after greasing its entire face.
- 6) Install booster piston to booster No. 2 body.



Special tool (09917-68210)

**Fig. 19-84**

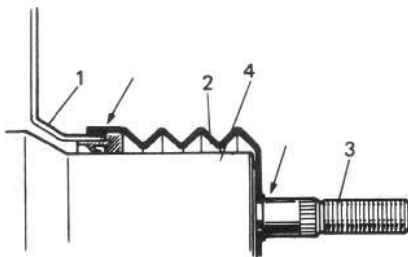


- 1. Booster No. 2 body
- 2. Diaphragm
- 3. Pressure plate

Check all around booster No. 2 body to make sure that diaphragm is seated securely in its outer groove as shown in "A".

**Fig. 19-85**

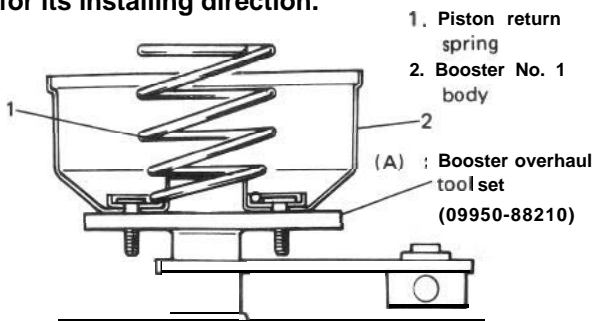
- 7) Install air cleaner separator and then 2 elements to rod of air valve assembly.
- 8) Install body boot to booster No. 2 body. Both ends of boot must be fitted securely as shown.



- 1. No. 2 body
- 2. Boot
- 3. Rod
- 4. Booster piston

**Fig. 19-86**

- 9) Place No. 1 body on special tool (A). Then install piston return spring, being careful for its installing direction.

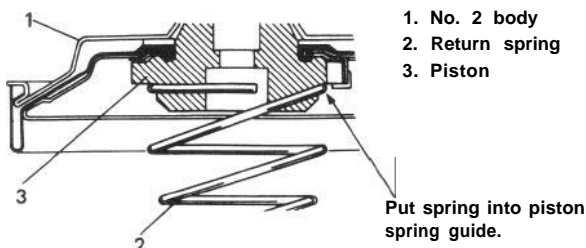


- 1. Piston return spring
- 2. Booster No. 1 body

(A) : Booster overhaul tool set (09950-88210)

**Fig. 19-87**

- 10) Place booster No. 2 body on piston return spring. Then check to be sure that spring is in piston spring guide.



- 1. No. 2 body
- 2. Return spring
- 3. Piston

Put spring into piston spring guide.

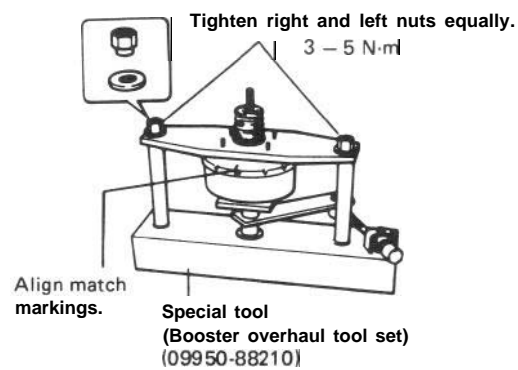
**Fig. 19-88**

- 11) Put No. 1 and No. 2 bodies together by aligning markings made before disassembly. Holding No. 2 body with upper plate (special tool) as shown, torque 2 nuts equally to specification.

Special tool nuts tightening torque	N·m	kg·m	lb·ft
	3 - 5	0.3 - 0.5	2.2 - 3.6

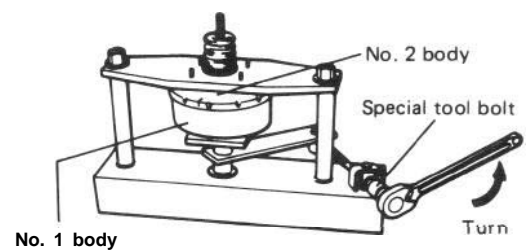
**NOTE:**

When holding No. 2 body, use care so that diaphragm is not caught by projections at 16 locations around No. 1 body.



**Fig. 19-89**

- 12) Turn special tool bolt counterclockwise until No. 1 body projecting part comes to mid-position of No. 2 body depressed parts as shown.



No. 1 body projecting part



No. 2 body depressed part

**Fig. 19-90**

- 13) Remove booster from special tool and install push rod clevis so that below measurement "A" is obtained and torque nut to specification.

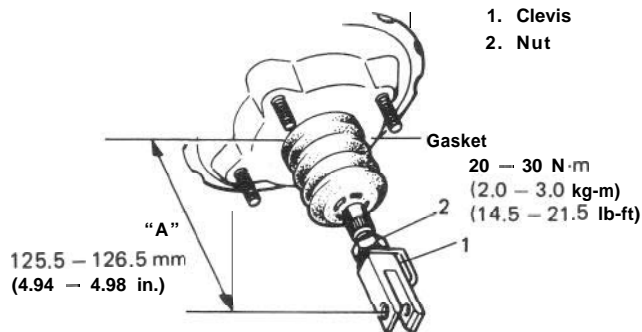


Fig. 19-91

- 14) Insert piston rod into booster piston.

**NOTE:**

Whenever booster was disassembled, make sure to check clearance between piston rod and master cylinder piston after reassembly. (For details, refer to p. 19-33.)

**INSTALLATION**

**NOTE:**

See NOTE at the beginning of this section.

Adjust clearance between booster piston rod and master cylinder piston with special tool. (See page 19-33.)

Check length of push rod clevis. (Refer to Fig. 19-91).

- 1) Install booster to dash panel as shown. Then connect booster push rod clevis to pedal arm with pin and split pin.
- 2) Torque booster attaching nuts to specification.
- 3) Install master cylinder to booster and torque attaching nuts to specification.
- 4) Connect 2 brake pipes and torque flare nuts to specification. (See p. 19-29).
- 5) Fill reservoir with specified fluid.
- 6) Bleed air from brake system. (See BLEEDING BRAKES on p. 19-46).
- 7) After installing, check pedal height and play. (See p. 19-43).

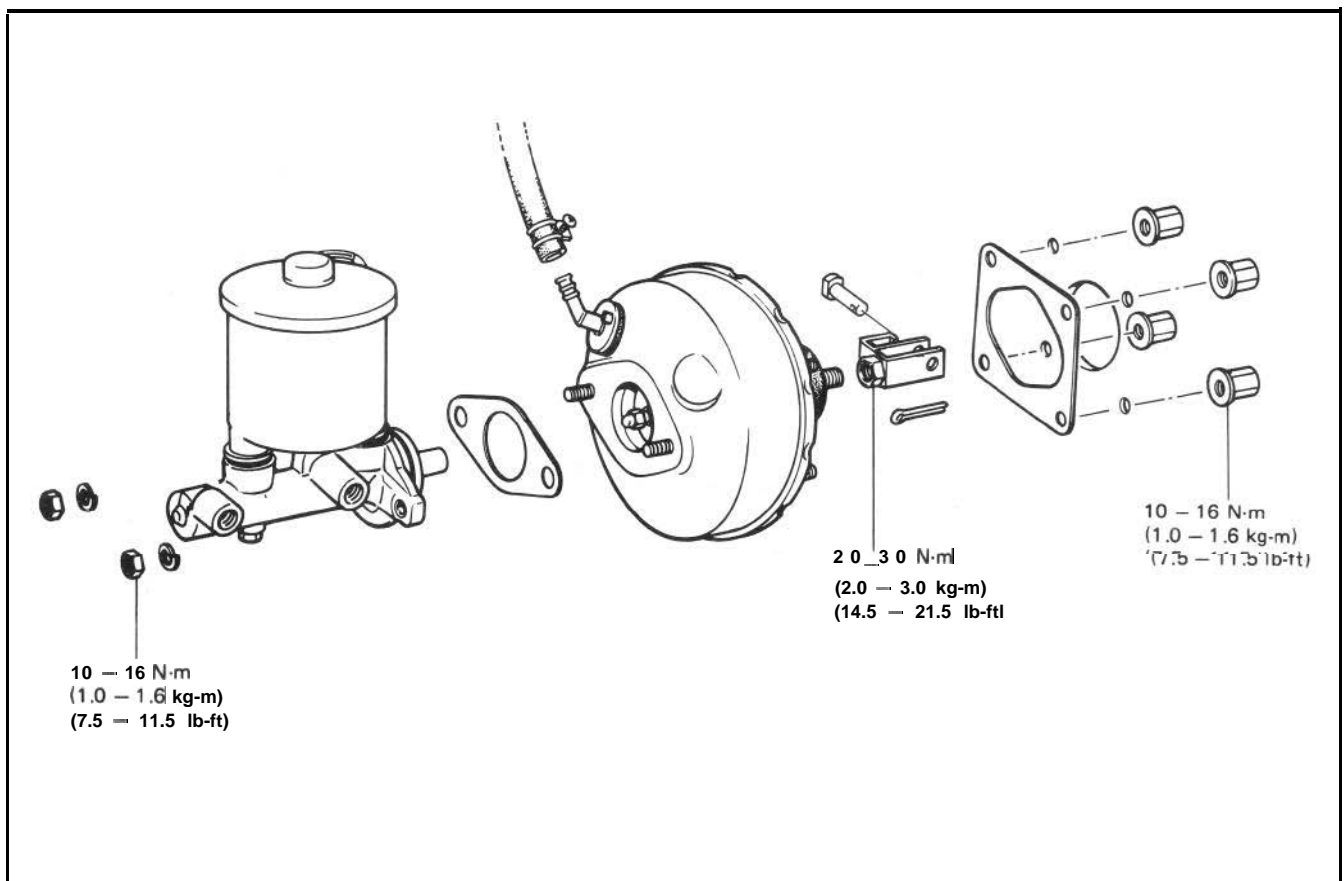


Fig. 19-92



## 19-6. PARKING BRAKE

### NOTE:

For parking brake inspection and adjustment, refer to p. 19-44 under 19-8 MAINTENANCE SERVICE in this section.

### INSTALLATION

- If parking brake cable was removed and reinstalled, make sure to clamp it properly according to illustrated instruction for each clamp in the figure below.
- After installing cable, check the following;
  - \* Parking brake lever stroke is within specification
  - \* Parking brake operates properly
  - \* Brake is free from dragging

For stroke data and cable adjustment, refer to p. 19-44 and 19-45 under 19-8 MAINTENANCE SERVICE in this section.

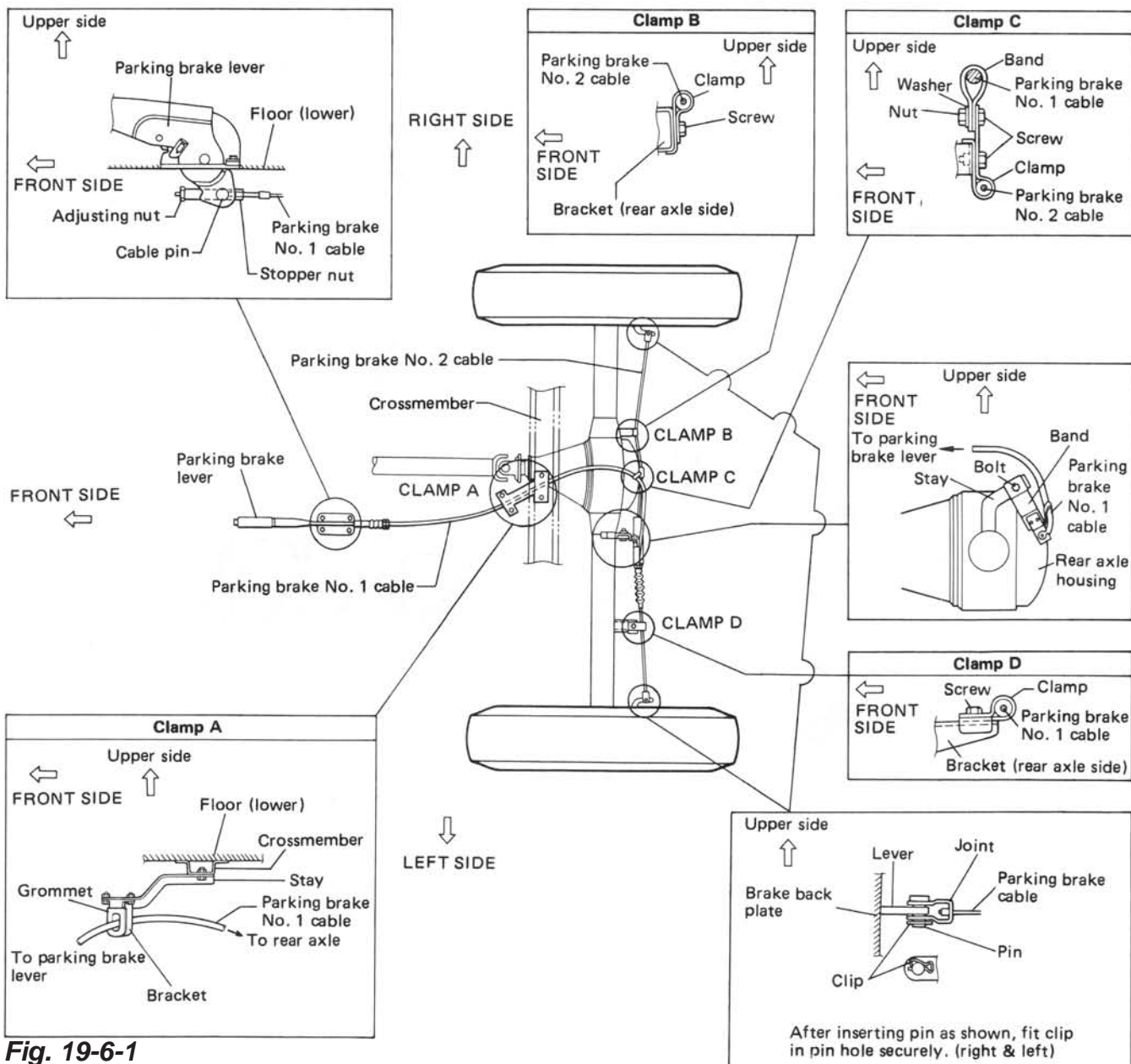


Fig. 19-6-1

## 19-7. BRAKE PIPES AND HOSES

### REMOVAL AND INSTALLATION

- 1) Take out fluid with a syringe or such.
- 2) Clean dirt and foreign material from both hose end or pipe end fittings. Remove brake hose or pipe.
- 3) Reverse removal procedure for brake hose or pipe installation. When installing hose, make sure that it has no twists or kinks. Inspect to see that hose doesn't make contact with any part of suspension. Check in extreme right and extreme left turn conditions. If hose makes any contact, remove and correct. Fill and maintain brake fluid level in reservoir. Bleed brake system.

#### CAUTION:

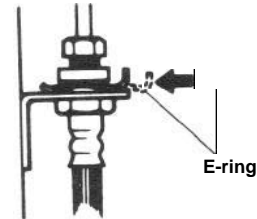
Refer to Fig. 19-38 when connecting brake flexible hose to brake caliper and tighten to specified torque.  
Be sure to install brake pipe in proper position referring to Fig. 19-7-2 and clamp it securely and correctly.

#### Tightening torque

	N·m	kg·m	lb·ft
Brake pipe flare nuts	14 – 18	1.4 – 1.8	10.5 – 13.0
Brake flexible hose bolt	20 – 25	2.0 – 2.5	14.5 – 18.0
6-way joint bolt	6 – 10	0.6 – 1.0	4.5 – 7.0
Proportioning valve bolt	6 – 10	0.6 – 1.0	4.5 – 7.0
Proportioning valve plate bolt	6 – 10	0.6 – 1.0	4.5 – 7.0

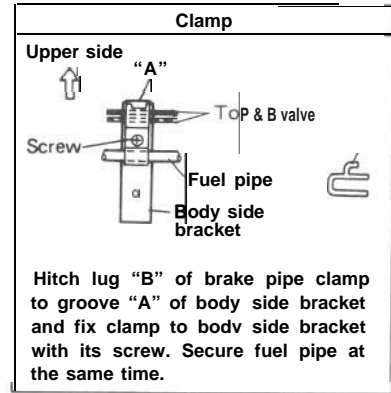
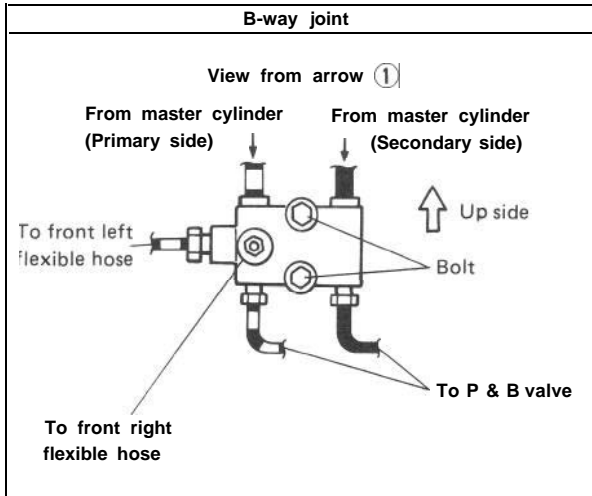
#### NOTE:

Be sure to install brake flexible hose E-ring into hose groove.



*Fig. 19-7-1*

Upon completion of installation, check each joint for fluid leakage with brake pedal depressed.



**Brake flexible hose and E-ring**

Make sure that flexible hose is not twisted when it is installed or connected to the pipe.

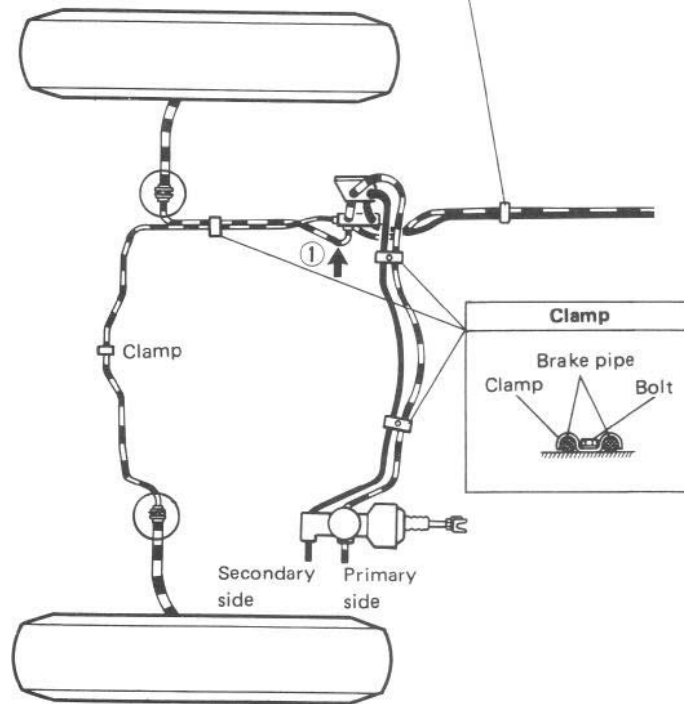
When installing flexible hose to bracket, align 6 vertexes of metal fixture on hose with internal angles of bracket.

Insert E-ring till E-ring end surface is flush with or lower than bracket end surface. (Refer to p. 19-39.)

For installation of flexible hose to brake caliper, refer top. 19-19.

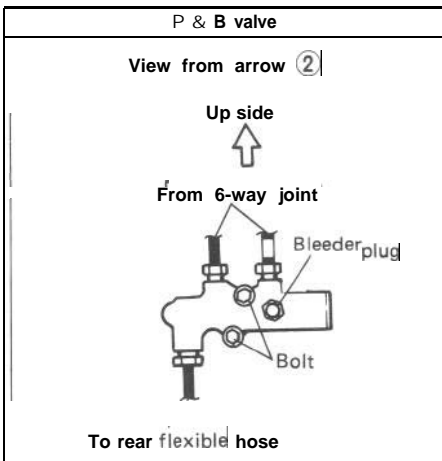
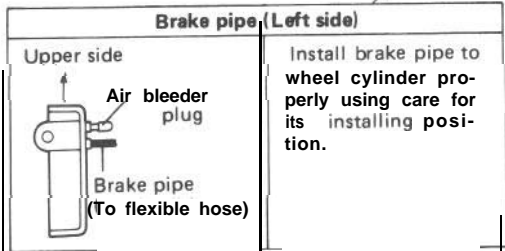
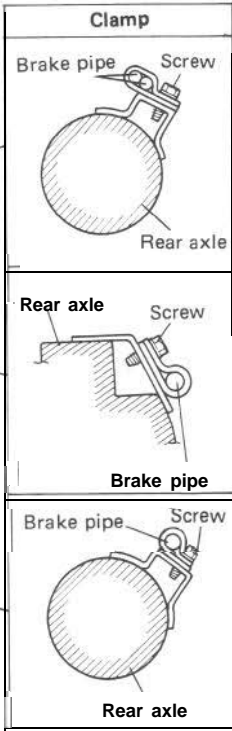
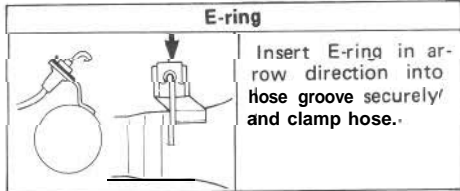
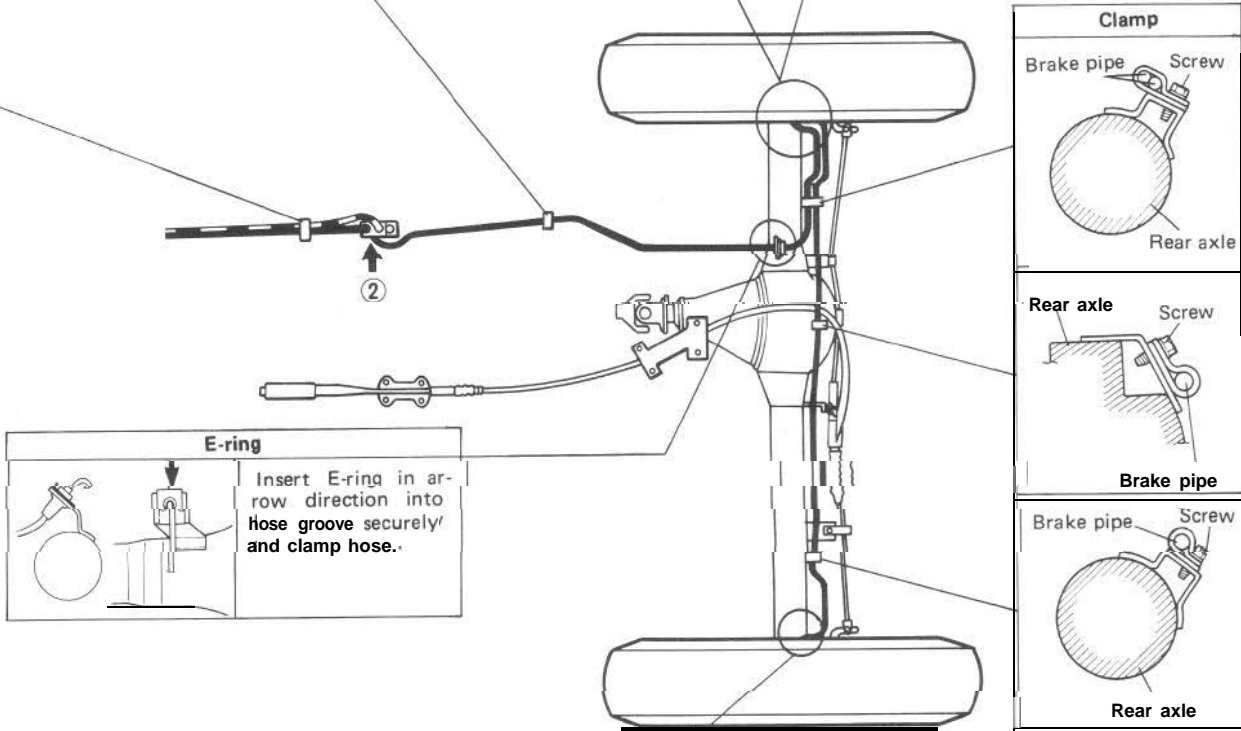
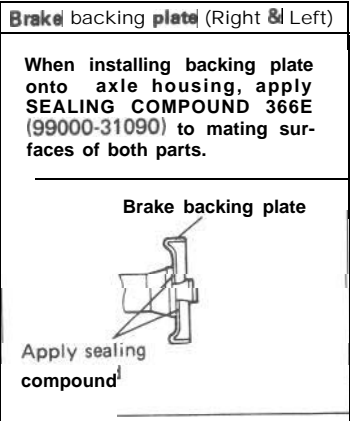
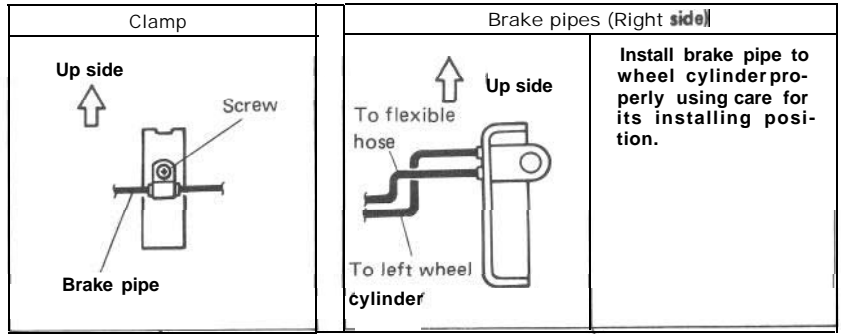
Install the flexible hose so that it won't be kinked when the steering wheel is straightened.

After installing the flexible hose, turn the steering wheel to the right fully and check that the clearance between the wheel/tire and flexible hose is larger than 25 mm (0,984 in) in that state and then check likewise with the steering wheel turned to the full left position. (This is to ensure that more than 25 mm (0.984 in) clearance is maintained even when bumping or rebounding fully).



**Fig. 19-7-2**





## 19-8. MAINTENANCE SERVICE

### ROAD TESTING BRAKES

Brakes should be tested on dry, clean, smooth and reasonably level roadway which is not crowned. Road test brakes by making brake applications with both light and heavy pedal forces at various speeds to determine if the car stops evenly and effectively.

Also drive car to see if it leads to one side or the other without brake application. If it does, check tire pressure, front end alignment and front suspension attachments for looseness. See diagnosis chart for other causes.

### BRAKE FLUID LEAKS

Check master cylinder fluid levels. While a slight drop in reservoir level does result from normal lining wear, an abnormally low level indicates a leak in the system. In such a case, check the entire brake system for leakage. If even a slight evidence of leakage is noted, the cause should be corrected or defective parts should be replaced.

### BRAKE FLUID LEVEL INSPECTION

Be sure to use particular brake fluid either as marked on reservoir cap of that car or recommended in owner's manual which comes along with that car.

Use of any other fluid is strictly prohibited.

Fluid level should be between MIN and MAX lines marked on reservoir.

When warning light lights sometimes during driving, replenish fluid to MAX line.

When fluid decreases quickly, inspect brake system for leakage. Correct leaky points and then refill to specified level.



**Fig. 19-8-1**

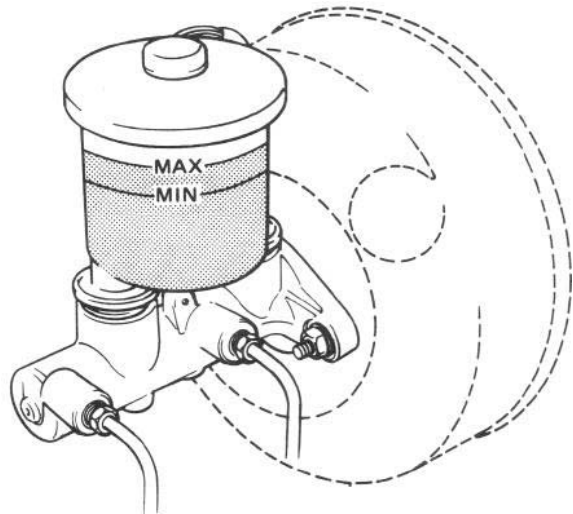
## FILL RESERVOIR

### CAUTION:

Do not use shock absorber fluid or any other fluid which contains mineral oil. Do not use a container which has been used for mineral oil or a container which is wet from water. Mineral oil will cause swelling and distortion of rubber parts in the hydraulic brake system and water will mix with brake fluid, lowering the fluid boiling point. Keep all fluid containers capped to prevent contamination.

Fluid to fill reservoir which is indicated on reservoir cap of the car with embossed letters or in owner's manual supplied with the car.

Add fluid up to MAX line.



**Fig. 19-8-2**

## BRAKE PEDAL FREE HEIGHT ADJUSTMENT

Brake pedal height is normal if brake pedal is as high as clutch pedal.

- 1) When booster push rod clevis has been reinstalled, it is important that measurement between booster mounting surface (with a gasket attached) and the center of clevis pin hole is adjusted within 125.5 mm – 126.5 mm (4.94 – 4.98 in.). (See page 19-37.)
- 2) When stop light switch has been removed, refer to the following STOP LIGHT SWITCH ADJUSTMENT for proper installation. The services in above steps 1) and 2) may affect brake pedal height.

## STOP LIGHT SWITCH ADJUSTMENT

Adjustment should be made as follows when installing the switch.

Pull up brake pedal toward you and while holding it there, adjust switch position so that clearance between the end of thread and brake pedal contact plate (shown as "A" in figure) is within 0.5 – 1.0 mm (0.02 – 0.04 in.). Then tighten lock nut to specified torque.

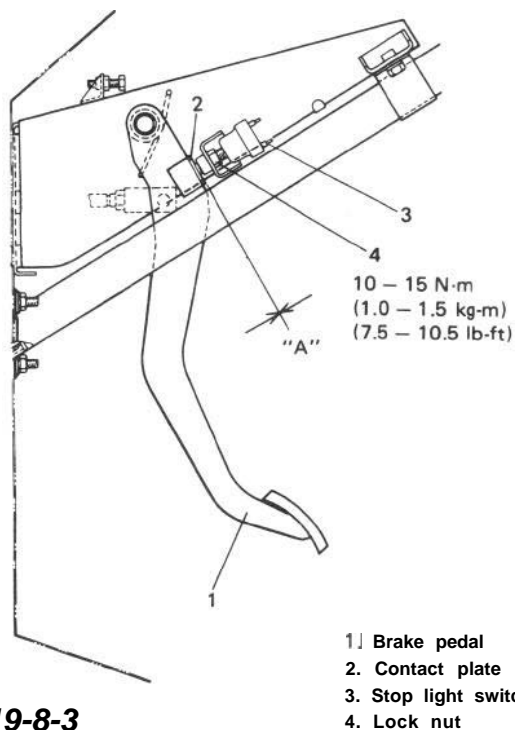


Fig. 19-8-3

## EXCESSIVE PEDAL TRAVEL CHECK

- 1) Start the engine.
- 2) Depress brake pedal a few times.
- 3) With brake pedal depressed with approximately 30 kg (66 lbs) load, measure pedal arm to wall clearance "B". It mustn't be less than 75 mm (2.95 in.).

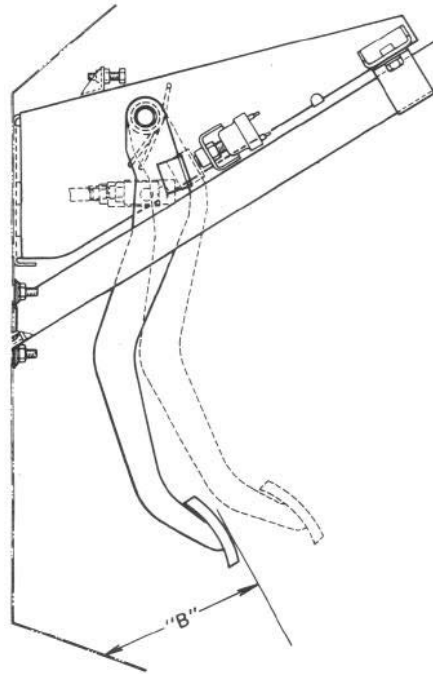


Fig. 19-8-4

- 4) If clearance "B" is less than 75 mm (2.95 in.), the most possible cause is either rear brake shoes are worn out beyond limit or air is in lines.

Should clearance "B" remain less than 75 mm (2.95 in.) even after replacement of brake shoes and bleeding of system, other possible but infrequent cause is malfunction of rear brake shoe adjusters or booster push rod length out of adjustment for the car with brake booster.

See p. 19-22 for brake shoe inspection.

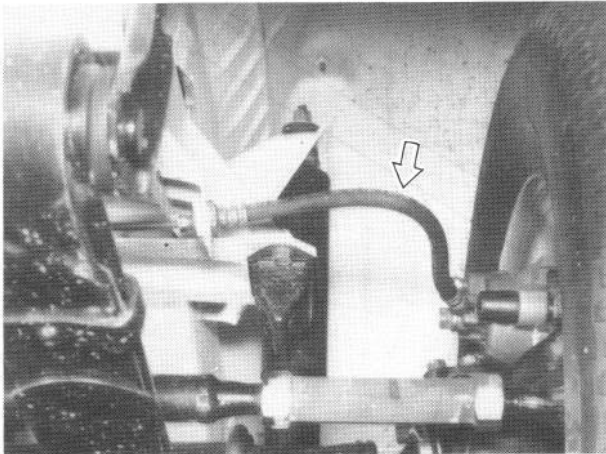
See p. 19-46 for bleeding brake system.

Remove brake drums for adjuster inspection. (See p. 19-23.) If defective, correct or replace.

## BRAKE HOSE AND PIPE INSPECTION

### Hose

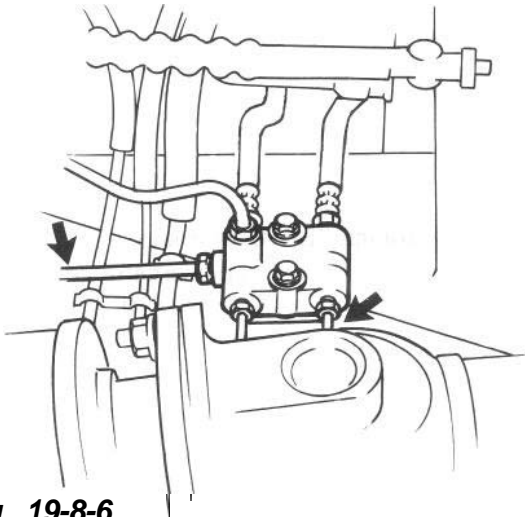
The brake hose assembly should be checked for road hazard damage, for cracks and chafing of outer cover, for leaks and blisters. A light and mirror may be needed for an adequate inspection. If any of the above conditions are observed on brake hose, it will be necessary to replace it.



**Fig. 19-8-5**

### Pipe

Inspect the tube for damage, cracks, dents and corrosion. If any defect is found, replace it.



**Fig. 19-8-6**

## PAD LINING INSPECTION

Inspect pad linings periodically according to maintenance schedule and whenever wheels are removed (for tire rotation or other reason).

For wear check of pad linings, refer to p. 19-16.

## DISC INSPECTION

Inspect disc periodically according to maintenance schedule.

For more information, refer to p. 19-17.

## REAR BRAKE SHOE & LINING INSPECTION

Inspect brake shoe & lining according to maintenance schedule.

For shoe and lining inspection, refer to p. 19-22.

## REAR BRAKE DRUM INSPECTION

Inspect brake drum according to maintenance schedule.

For more information, refer to p. 19-21.

## PARKING BRAKE INSPECTION AND ADJUSTMENT

### 1) Parking brake lever stroke inspection.

Hold the center of parking brake lever grip and pull it up with 20 to 25 kg (44 to 55 lb) force.

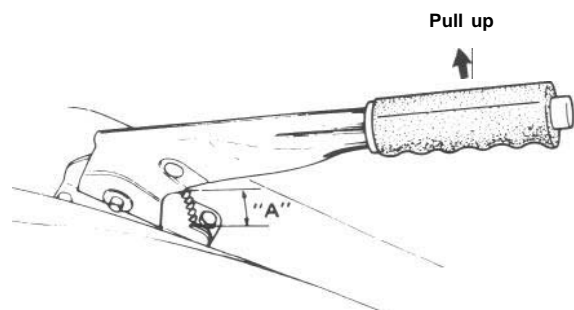
With parking brake lever pulled up as above, count ratchet notches in "A" as shown in figure. There should be 3 to 8 notches.

Also, check if both right and left rear wheels are locked firmly.

If number of notches is out of specification, adjust cable by referring to adjustment procedure described on the next page so as to obtain specified parking brake stroke.

### NOTE:

Check tooth tip of each notch for damage or wear. If any damage or wear is found, replace parking brake lever.



Parking brake stroke "A": When lever is pulled up at 20 kg (44 lb).	Within 3 - 8 notches
--	----------------------------

**Fig. 19-8-7**

- 2) Parking brake lever stroke adjustment
- a) If parking brake lever stroke was found out of specification when checked as described on the previous page, adjust parking brake cable.

NOTE:

**Make sure for following conditions before cable adjustment.**

- No air is trapped in brake system.**
- Brake pedal travel is proper.**
- Brake pedal has been depressed a few times with about 30 kg (66 lbs) load.**
- Parking brake lever has been pulled up a few times with about 20 kg force.**
- Rear brake shoes are not worn beyond limit, and self adjusting mechanism operates properly.**

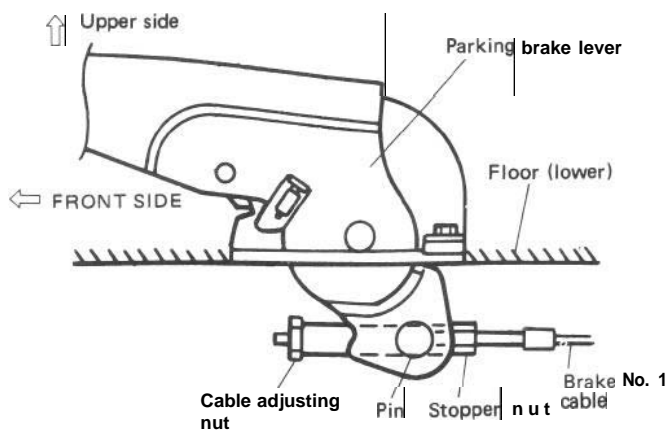
- b) After confirming that above 5 conditions are all satisfied, adjust parking brake lever stroke by loosening or tightening adjusting nut indicated in figure and tighten stopper nut to the pin.

NOTE:

**For cable adjustment, loosen stopper nut and turn adjusting nut while holding hold nut with spanner so as to prevent inner cable from getting twisted.**

**Check brake drum for dragging after adjustment.**

Parking brake stroke; when lever is pulled up at 20 kg (44 lb)	Within 3 – 8 notches
--	----------------------



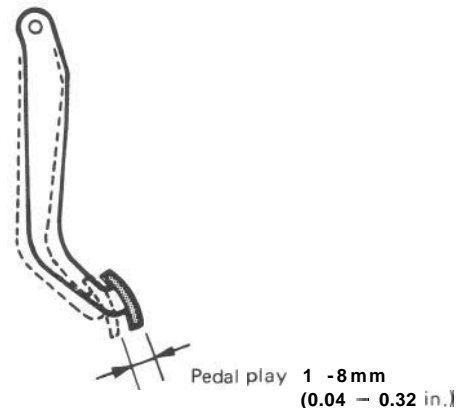
**Fig. 19-8-8**

- 3) Parking brake cable inspection
- Check brake cable for damage and also for smooth movement. Replace if deteriorated.

### BRAKE PEDAL PLAY INSPECTION

Pedal play should be within below specification. If out of specification, check stop light switch for proper installation position and adjust if necessary.

Also check pedal shaft bolt and master cylinder pin installation for looseness and replace if defective.



**Fig. 19-8-9**

### REAR DRUM BRAKE SHOE ADJUSTMENT

Rear brake has self-adjusting mechanism but it does require adjustment for proper drum to shoe clearance when brake shoe has been replaced or brake drum has been removed for some other service.

Adjustment is automatically accomplished by depressing brake pedal 3 to 5 times with approximately 30 kg (66 lbs) load after all parts are installed.

Then check brake drum for dragging and brake system for proper performance. After lowering car from lift, brake test should be performed.

### FLUSHING BRAKE HYDRAULIC SYSTEM

It is recommended that entire hydraulic system be thoroughly flushed with clean brake fluid whenever new parts are installed in hydraulic system.

Periodical change of brake fluid is also recommended.

## BLEEDING BRAKES

### NOTE:

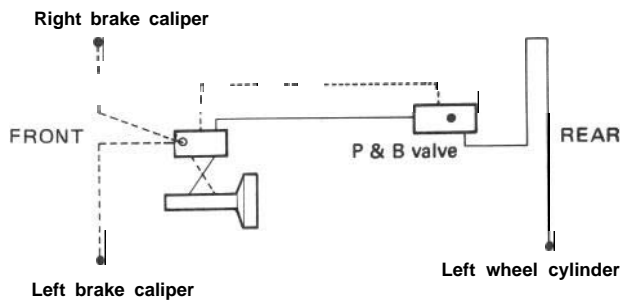
Brake fluid is extremely damaging to paint. If fluid should accidentally touch painted surface, immediately wipe fluid from paint and clean painted surface.

With this vehicle, air bleeding is required at four places: right and left front wheels, P & B valve and rear wheel cylinder on left side as marked with dot (●) in Fig. 19-8-10. And at each of these places, there is air bleeder plug.

Whenever brake pipe or hose has been disconnected at any place, carry out air bleeding so as to make sure that no air remains in brake circuit.

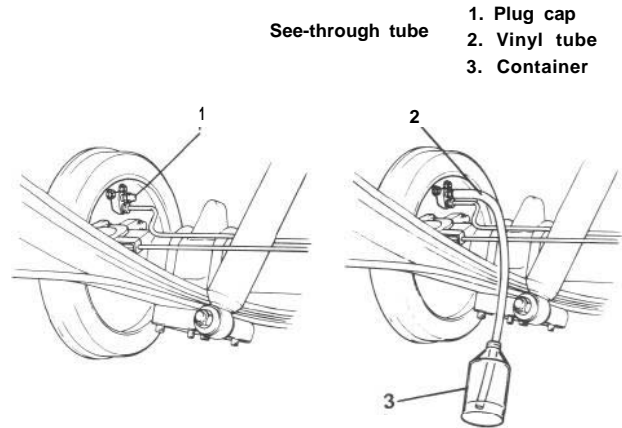
### CAUTION:

Upon completion of air bleeding at four places, be sure to tighten each air bleeder plug to specified torque and check entire brake circuit to make sure that no fluid leakage exists.



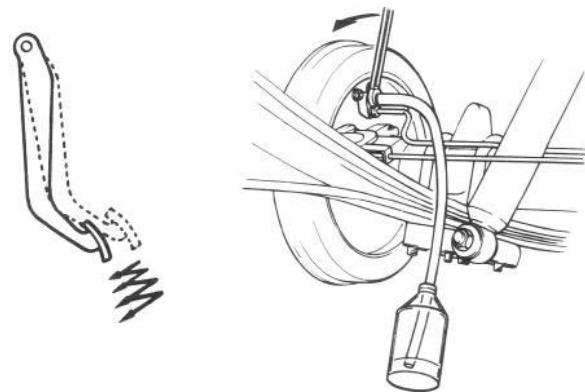
**Fig. 19-8-10**

- 1) Fill master cylinder reservoir with brake fluid and keep at least half filled during bleeding operation.
- 2) Remove bleeder plug cap. Attach vinyl tube to bleeder plug of wheel cylinder, and insert the other end into container.



**Fig. 19-8-11**

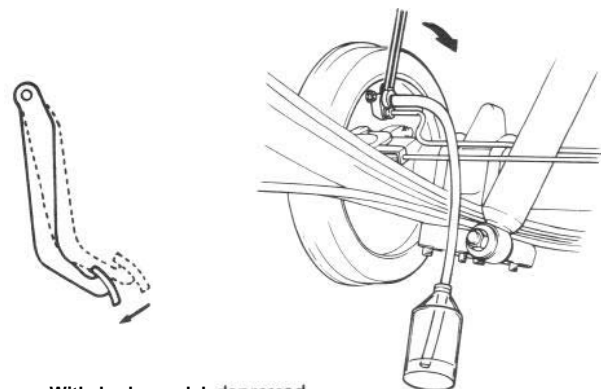
- 3) Depress brake pedal several times, and then while holding it depressed, loosen bleeder plug about one-third to one-half turn.



Depress brake pedal several times and with pedal depressed, loosen bleeder plug a little.

**Fig. 19-8-12**

- 4) When fluid pressure in the cylinder is almost depleted, retighten bleeder plug.

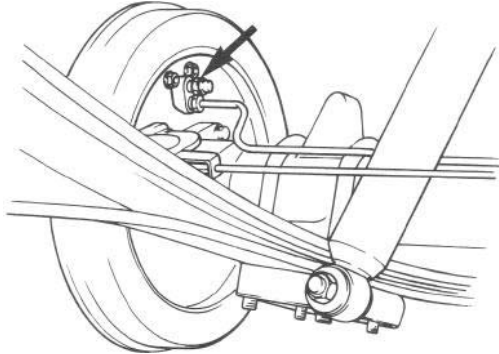


With brake pedal depressed, retighten bleeder plug.

**Fig. 19-8-13**



- 5) Repeat this operation until there are no more air bubbles in hydraulic line.
- 6) When bubbles stop, depress and hold brake pedal and tighten bleeder plug.
- 7) Then attach bleeder plug cap.



**Fig. 19-8-14**

- 8) After completing bleeding operation, apply fluid pressure to pipe line and check for leakage.
- 9) Replenish fluid into reservoir up to specified level.



**Fig. 19-8-15**

- 10) Check brake pedal for "sponginess". If found spongy, repeat entire procedure of bleeding.

## INSPECT BOOSTER OPERATION

There are two ways to perform this inspection, with and without a tester. Ordinarily, it is possible to roughly determine its condition without using a tester.

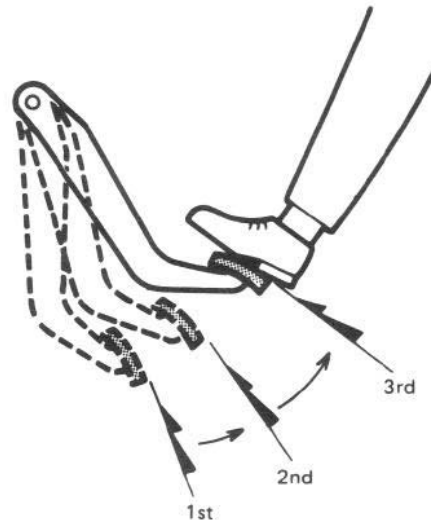
### NOTE:

For this check, make sure that no air is in hydraulic line.

## INSPECTION WITHOUT TESTER

### Check Air Tightness

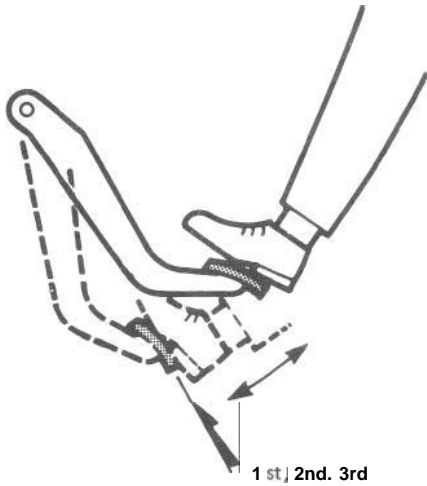
- 1) Start engine.
- 2) Stop engine after running for 1 or 2 minutes.
- 3) Depress brake pedal several times with the same load as in ordinary braking and observe pedal travel. If pedal goes down deep the first time but its travel decreases as it is depressed the second and more times, air tightness is obtained.



GOOD

**Fig. 19-8-16**

4) If pedal travel doesn't change, air tightness isn't obtained.



NO GOOD

Fig. 19-8-17

**NOTE:**

If defective, inspect vacuum lines and sealing parts, and replace any faulty part. When this has been done, repeat the entire test!

**Check Operation**

1) With engine stopped, depress brake pedal several times with the same load and make sure that pedal travel doesn't change.

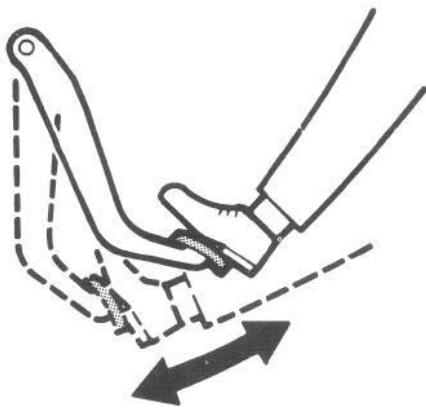


Fig. 19-8-18

2) Start engine while depressing brake pedal. If pedal travel increases a little, operation is satisfactory. But no change in pedal travel indicates malfunction.

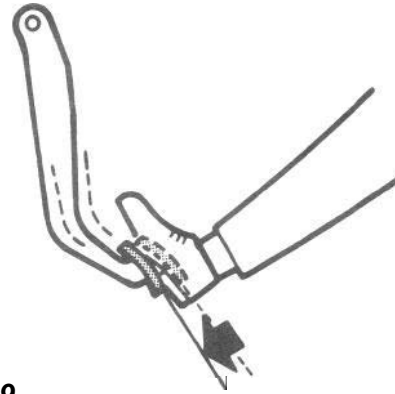


Fig. 19-8-19

**Check Air Tightness Under Load**

1) With engine running, depress brake pedal. Then stop engine while holding brake pedal depressed.

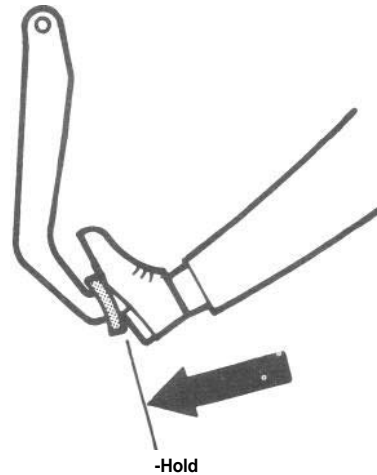


Fig. 19-8-20

2) Hold brake pedal depressed for 30 seconds. If pedal height does not change, condition is good. But it isn't if pedal rises.

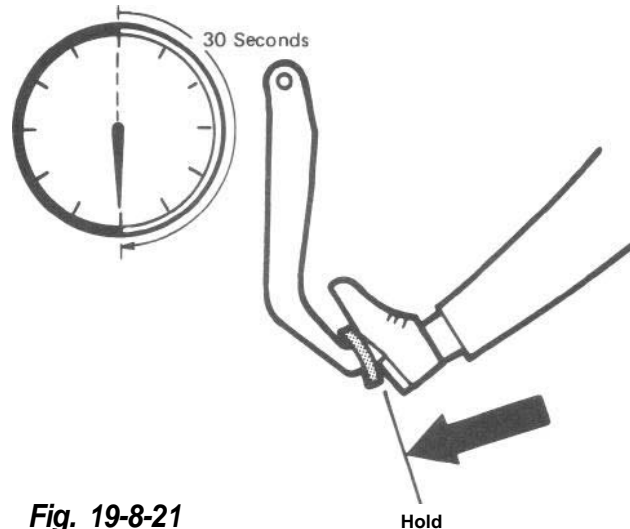


Fig. 19-8-21



## 19-9. TORQUE SPECIFICATION

Fastening parts	Tightening torque		
	N·m	kg-m	lb-ft
1. Brake caliper holder bolt	40 – 60	4.0 – 6.0	29.0 – 43.0
2. Brake carrier bolt	70 – 100	7.0 – 10.0	51.0 – 72.0
3. Brake caliper guide pin	25 – 30	2.5 – 3.0	18.5 – 21.5
4. Brake nut (Brake back plate nut)	1.8 – 2.8	1.8 – 2.8	13.5 – 20.0
5. Master cylinder nut	10 – 16	1.0 – 1.6	7.5 – 11.5
6. Booster nut	10 – 16	1.0 – 1.6	7.5 – 11.5
7. Brake pipe 6-way joint bolt	6 – 10	0.6 – 1.0	4.5 – 7.0
8. Brake flare nut	1.4 – 1.8	1.4 – 1.8	10.5 – 13.0
9. Brake pedal shaft nut	1.8 – 2.8	1.8 – 2.8	13.5 – 20.0
10. Universal joint flange nut	23 – 30	2.3 – 3.0	17.0 – 21.5
11. Brake flexible hose bolt	20 – 25	2.0 – 2.5	14.5 – 18.0
12. Proportioning and bypass valve bolt	6 – 10	0.6 – 1.0	4.5 – 7.0
13. Proportioning and bypass valve plate bolt	6 – 10	0.6 – 1.0	4.5 – 7.0
14. Brake flexible hose nut	2.0 – 4.0	2.0 – 4.0	14.5 – 28.5
15. Front brake caliper air bleeder plug	7 – 12	0.7 – 1.2	5.5 – 8.5

**SECTION 20**  
**BODY SERVICE**

**CONTENTS**

<b>20-1. FRONT DOOR</b> .....	<b>20-2</b>
<b>DESCRIPTION</b> .....	<b>20-2</b>
<b>REMOVAL</b> .....	<b>20-3</b>
<b>INSTALLATION</b> .....	<b>20-5</b>
<b>20-2. WINDSHIELD</b> .....	<b>20-8</b>
<b>CLEANING</b> .....	<b>20-8</b>
<b>INSTALLATION</b> .....	<b>20-9</b>
<b>20-3. BACK DOOR (APPLICABLE TO HARD TOP VEHICLE)</b> .....	<b>20-11</b>
<b>20-4. CHASSIS DIMENSIONS</b> .....	<b>20-13</b>

## 20-1. FRONT DOOR

### DESCRIPTION

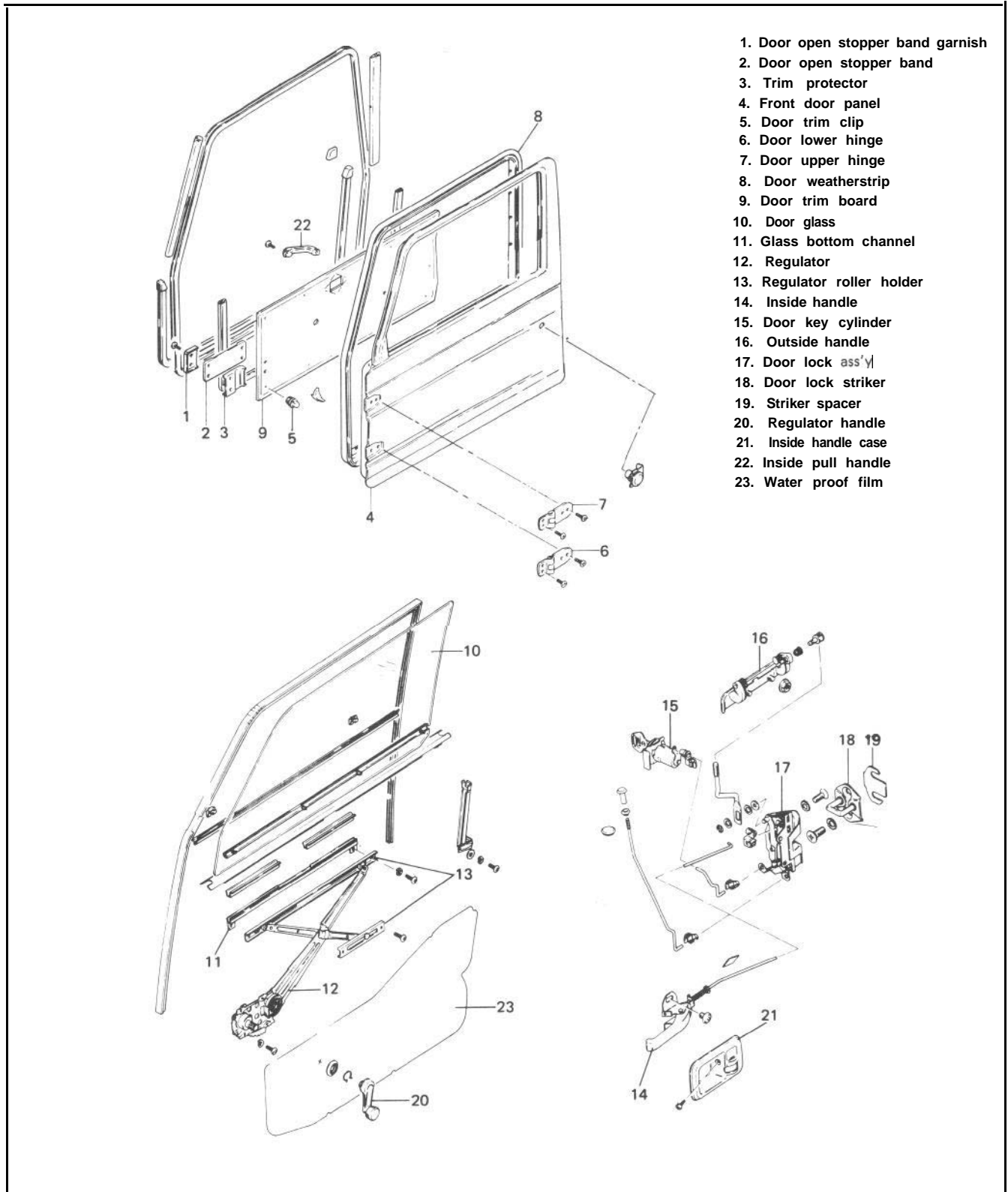
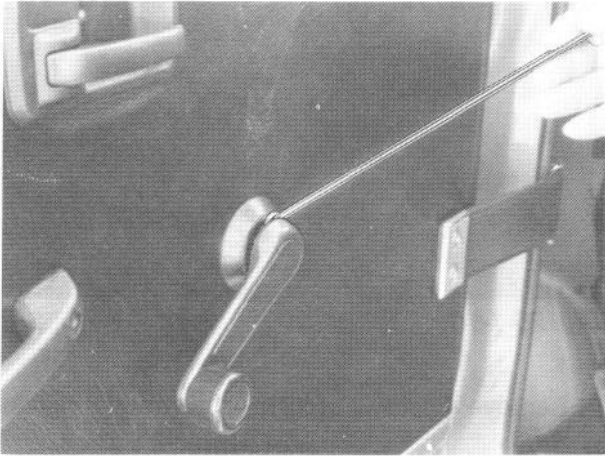


Fig. 20-1-1

## REMOVAL

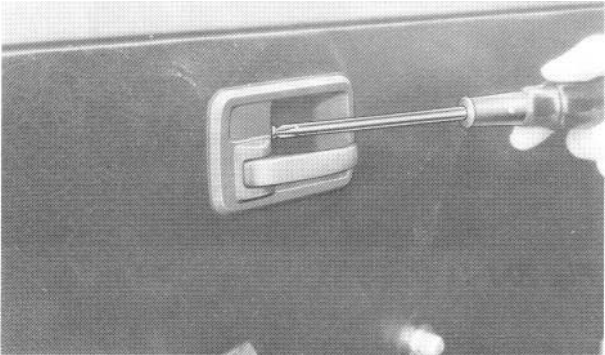
### Door Window Glass

- 1) Remove door window regulator handle.



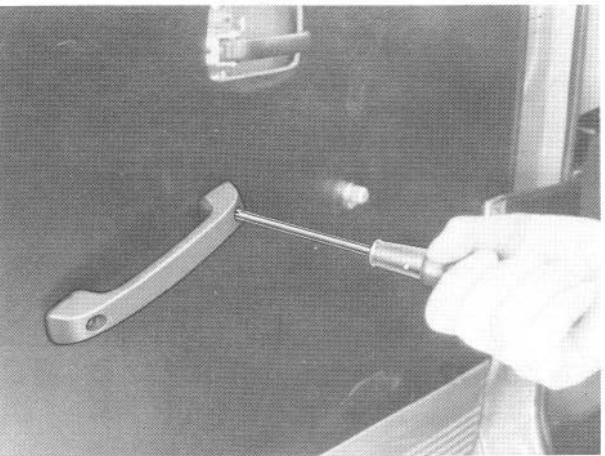
**Fig. 20-1-2**

- 2) Remove inside handle case.



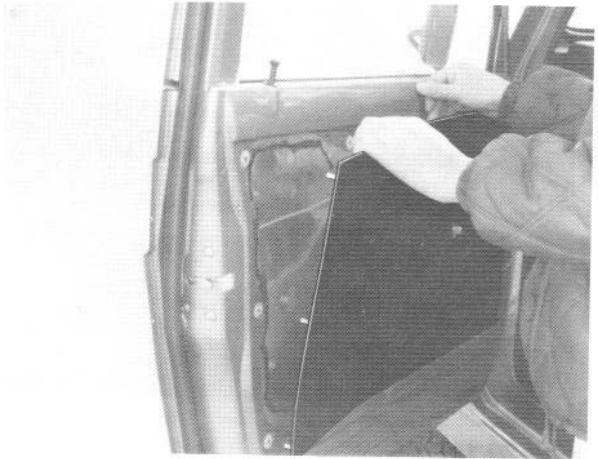
**Fig. 20-1-3**

- 3) Remove inside pull handle.



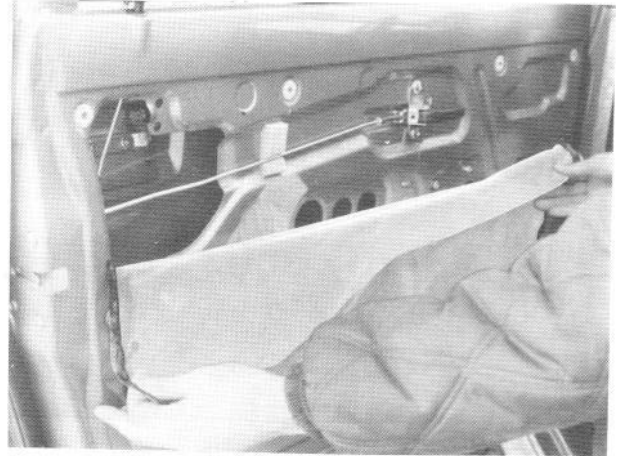
**Fig. 20-1-4**

- 4) Loosen two screws securing the stopper band, and take off the band.
- 5) Remove door trim board.



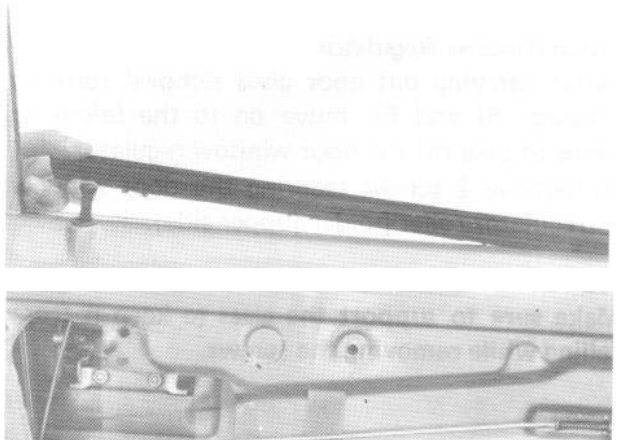
**Fig. 20-1-5**

- 6) Remove the door water proof film.



**Fig. 20-1-6**

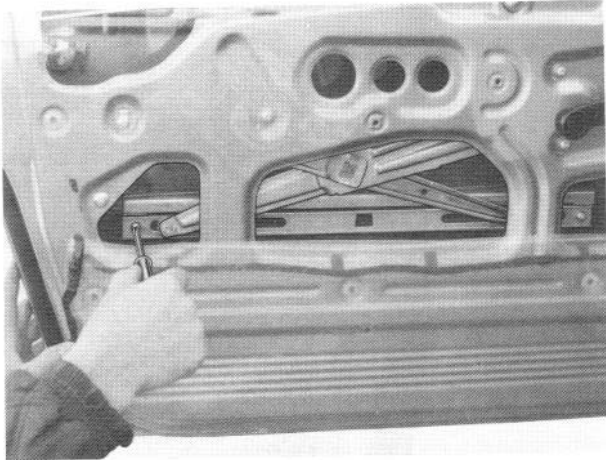
- 7) Remove the glass inside and outside scrape.



**Fig. 20-1-7**

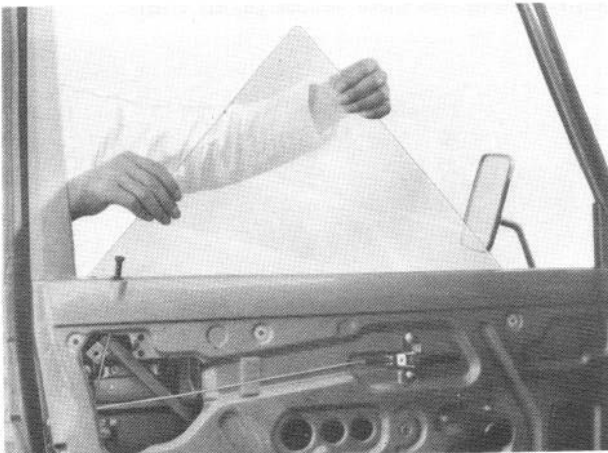


8) Remove 2 screws securing the door window regulator roller holder (lower side).



**Fig. 20-1-8**

9) Take out the glass.



**Fig. 20-1-9**

10) Detach glass from bottom channel.

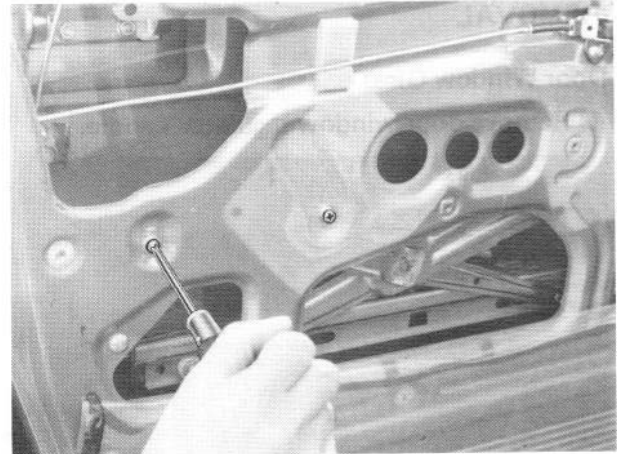
#### Door Window Regulator

After carrying out door glass removal steps 1) through 6) and 8), move on to the following steps to take off the door window regulator.

1) Remove 2 screws securing the door window regulator roller holder (upper side).

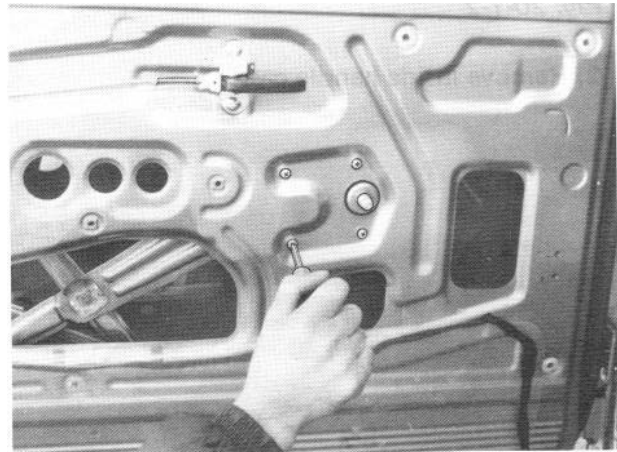
#### NOTE:

Make sure to support the glass to keep it from falling while removing the screws.



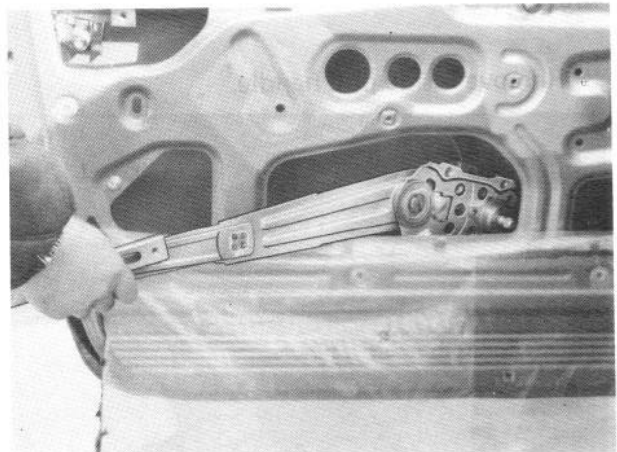
**Fig. 20-1-10**

2) Remove 4 screws securing the window regulator.

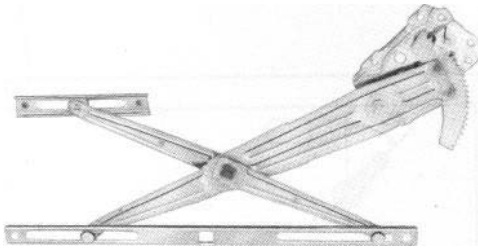


**Fig. 20-1-11**

3) Remove the window regulator.



**Fig. 20-1-12**

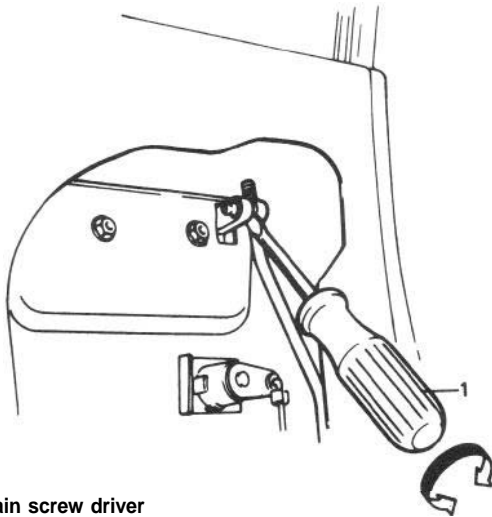


**Fig. 20-1-13**

**Front Door Lock**

After carrying out steps 1) through 6) of door glass removal, move on to the following step to take off the door lock.

After disconnecting each joint of control link, remove the door inside handle and door lock ass'y.



1. Plain screw driver

**Fig. 20-1-14**

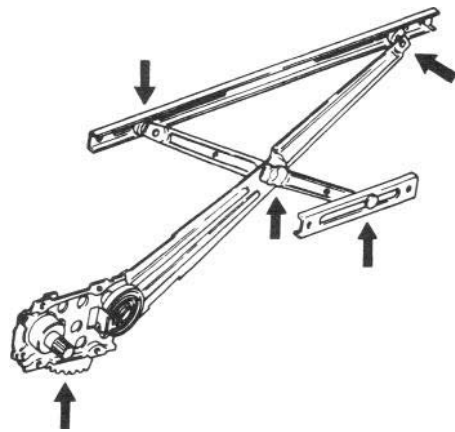
**INSTALLATION**

**Door Window Glass or Regulator**

Reverse the removal sequence to install the door window glass or regulator. However, be careful of the following points.

**[Door window regulator]**

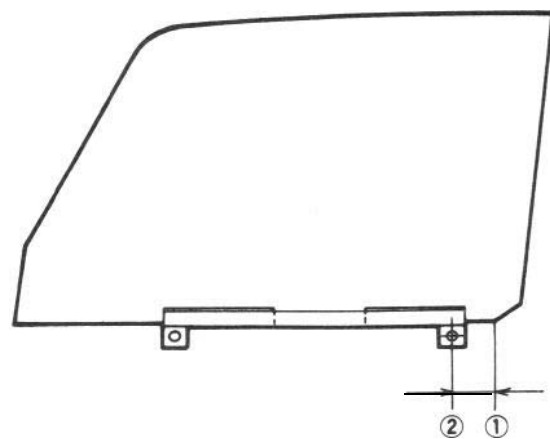
When installing door window regulator to door panel, apply multi-purpose grease to the sliding parts.



**Fig. 20-1-15**

**[Door glass]**

When fitting the glass bottom channel on the door glass, adjust the distance between the glass end (1) and channel end (2) to that indicated below.



**Fig. 20-1-16**

42 mm (1.65 in.)

When it is hard to raise and lower the door glass, the glass may be slanting towards the door sash. If this is the case, loosen the screws fastening the door regulator roller holder, move the holder up and down so that the glass and sash are brought in parallel.

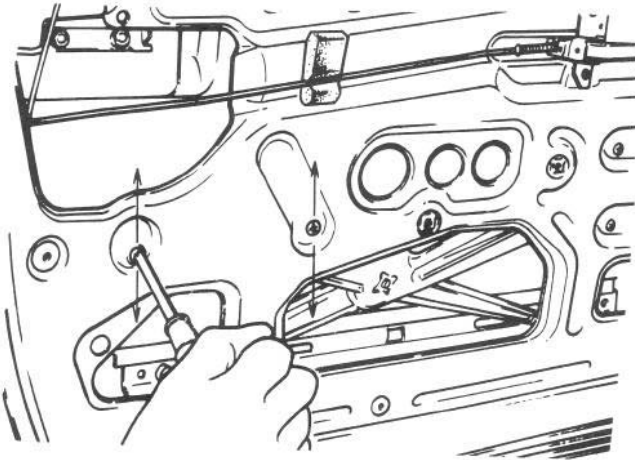


Fig. 20-1-17

[Water proof film]

A proof film that is broken a little may be mended with vinyl tape but should be replaced with polyethylene film as a rule. Apply bonding agent all around the circumference and stick on from the underside.

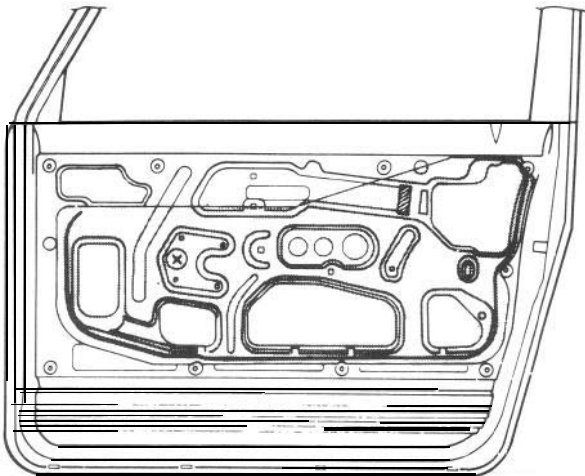


Fig. 20-1-18

[Regulator handle]

Install the handle at the angle as specified in below figure with the door window glass closed (raised all the way up).

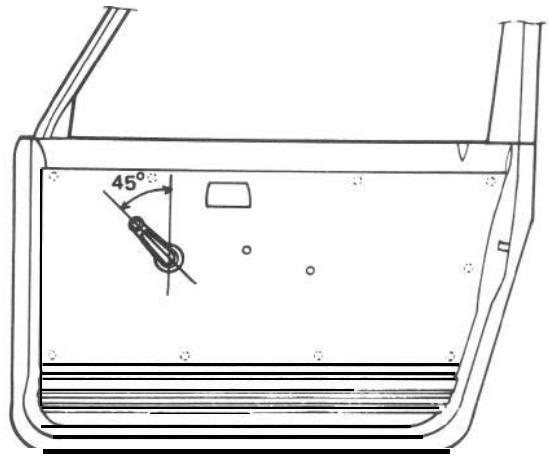


Fig. 20-1-19

Front Door Lock

Reverse the removal sequence to install the door lock. However, be careful of the following points.

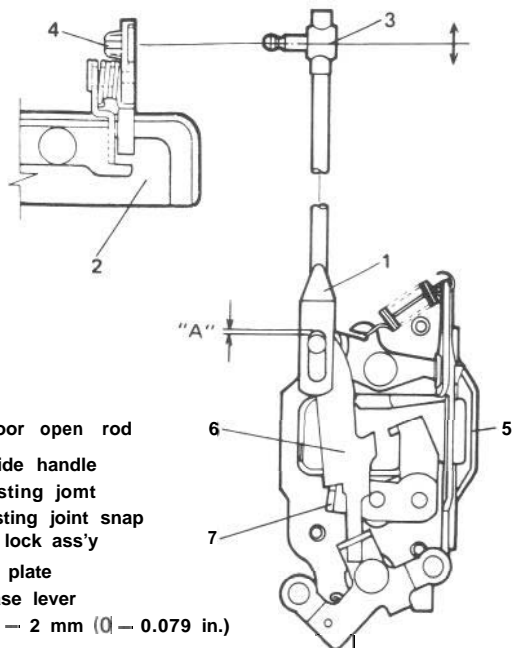
[Door outside open rod]

When installing open rod ① on outside handle ②, adjust clearance "A" to 0 – 2 mm (0 – 0.079 in) by turning adjusting joint ③.

NOTE:

Don't push down push plate ⑥ when installing the open rod.

After installing the open rod, give the outside handle a trial and check if its play felt then is appropriate.



1. Door open rod
2. Outside handle
3. Adjusting joint
4. Adjusting joint snap
5. Door lock ass'y
6. Push plate
7. Release lever

"A" : 0 – 2 mm (0 – 0.079 in.)

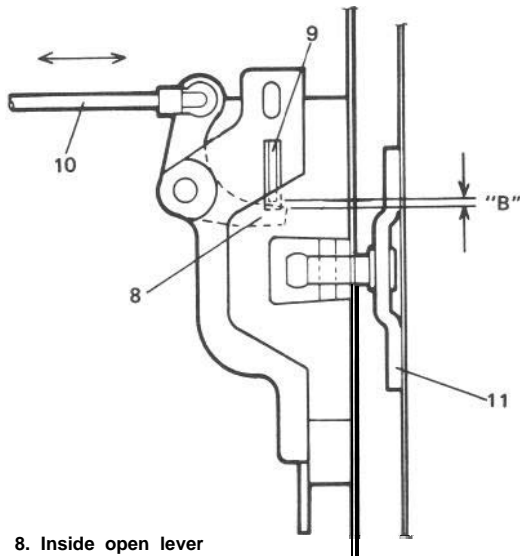
Fig. 20-1-20



**[Door lock inside handle]**

Fit the inside handle, adjusting the clearance between inside open lever ⑧ and outside open lever ⑨ of the door lock to 0 – 2 mm (0 – 0,079 in) by moving the inside handle remote control rod ⑩ in the arrow direction given in below figure.

After installation, give it a trial and check if its play felt then is appropriate.



- 8. Inside open lever
  - 9. Outside open lever
  - 10. Control rod
  - 11. Door lock striker
- "B": 0 – 2 mm (0 – 0.079 in.)

**Fig. 20-1-21**

**[Door lock rod pin]**

Fix the lock rod with rod pin securely as illustrated below.

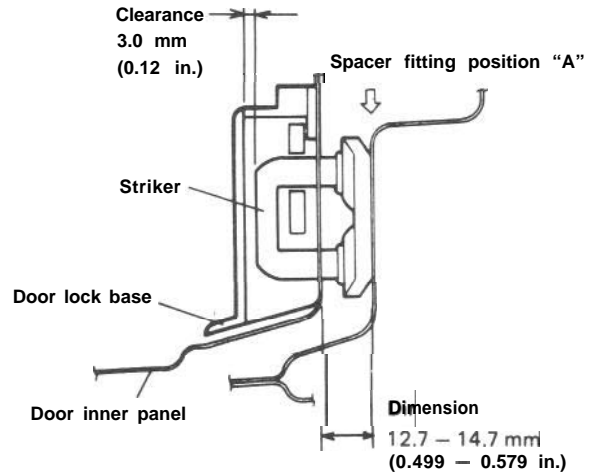


**Fig. 20-1-22**

**[Door lock striker]**

Increase or decrease striker spacers fitted in "A" position behind the striker to adjust dimensions to below values as shown in below figure.

After adjustment, check the difference in level between the door and body and adjust when there is difference by moving the door lock striker to right or left.

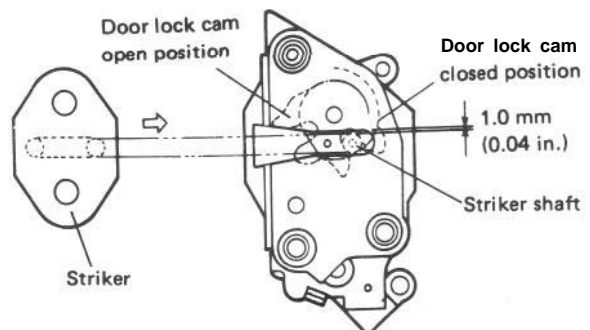


**Fig. 20-1-23**

Move the striker base up and down so that striker shaft aligns with the center of the groove of the door lock (the clearance between the shaft of door lock striker and lock base is 1.0 mm (0.04 in.)) in the vertical direction.

**CAUTION:**

- 1 The striker should be placed vertically.
- 1 Do not adjust the door lock.

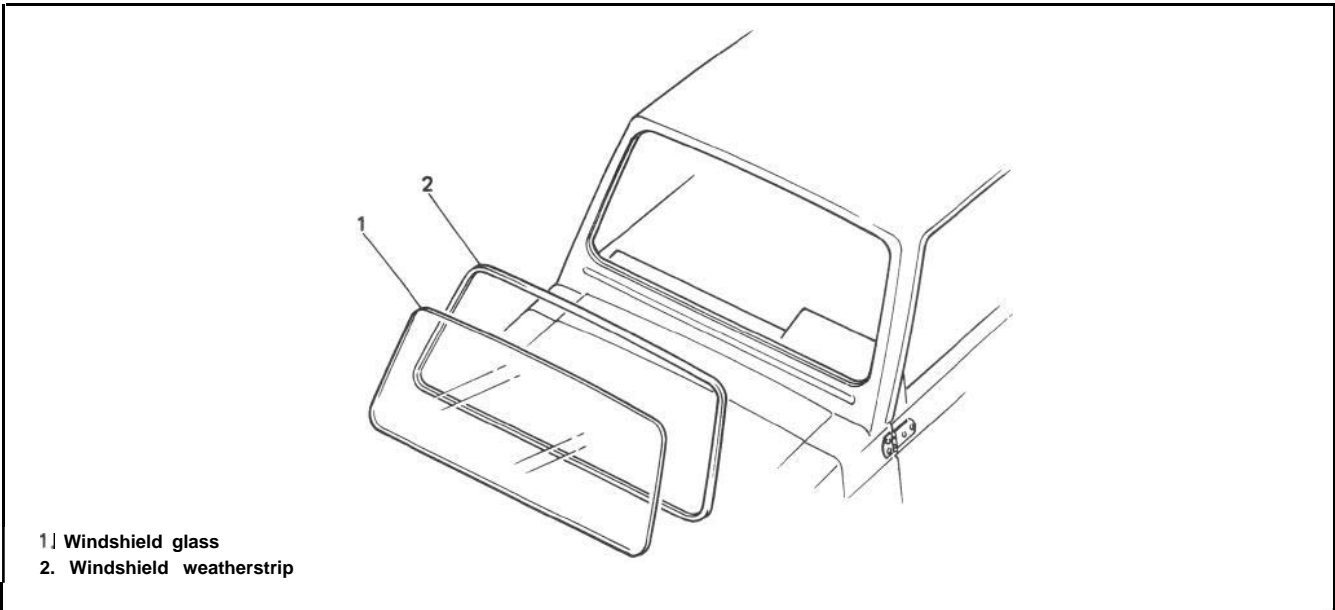


**Fig. 20-1-24**



## 20-2. WINDSHIELD

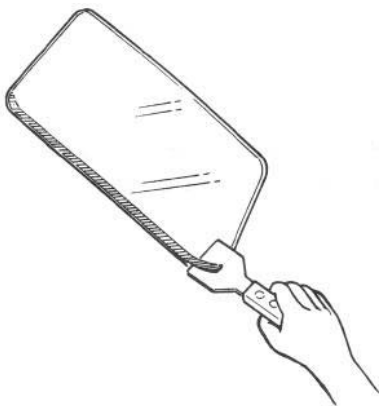
The windshield glass is bonded to the window panel (body) with weatherstrip in position. When replacing the glass, it is necessary to perform correct operation and adhesive selection so that adequate bonding strength can be obtained.



**Fig. 20-2-1**

### CLEANING

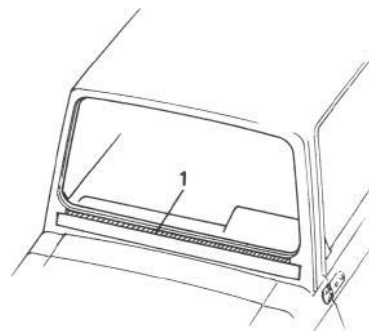
1) After removing the glass, remove the urethane gum sticking to the glass and window panel (body).



**Fig. 20-2-2**

#### NOTE:

When removing the urethane gum from the window panel (body), apply a masking tape along the edge of the gummed surface to protect the painted surface from damage.



1. Urethane gum

**Fig. 20-2-3**

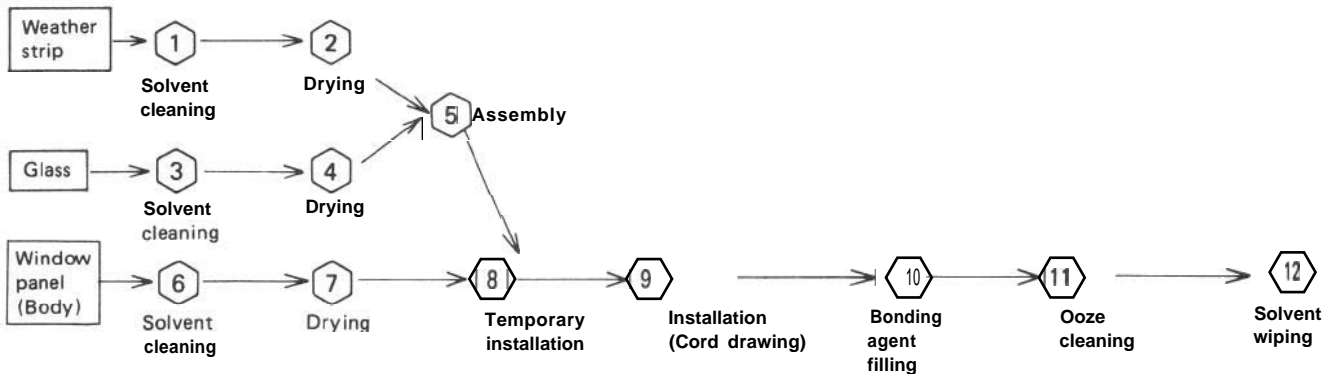
2. Use cleaning solvent to clean the glass and window panel (body).

#### NOTE:

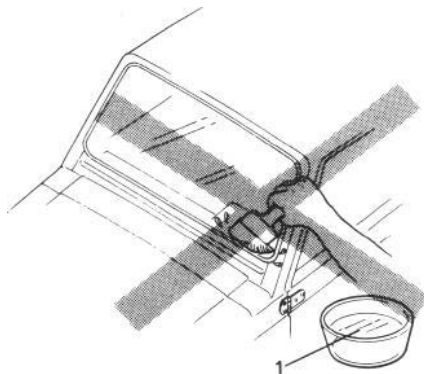
The use of alcohol or thinner when cleaning may adversely affect some kinds of adhesives in terms of bonding strength, resulting in that it is impossible to obtain adequate strength for glass installation. So, be careful sufficiently about the selection of the cleaning solvent

## INSTALLATION

The installation sequence is shown in the Block Diagram below.



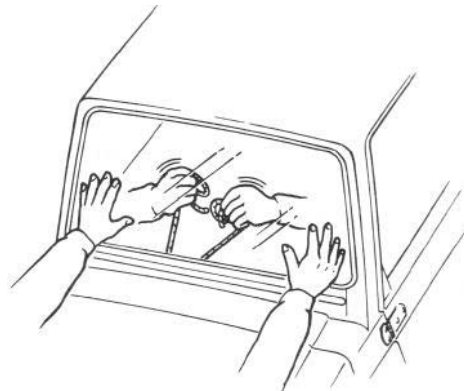
- 1) As for the cleaning, use cleaning solvent. The use of alcohol or thinner adversely affects some kinds of adhesives in terms of bonding strength. Hence, use sufficient care to select proper cleaning solvent.
- 2) When cleaning the weatherstrip, apply a 3 kg or more pressure on a clean cloth to wipe and clean it.
- 3) After cleaned with solvent, each item should not be touched by hand fouled with grease, etc.
- 4) Make a glass-and-weatherstrip assembly, Thereafter, carefully keep the assembly free from dust to assemble it to the window panel (body) as soon as possible.
- 5) Glass installation  
When assembling the glass into the weatherstrip's glass channel, and when assembling the glass-and-weatherstrip assembly to the window panel (body) soapy water must not be used as lubricant. If the installation is felt hard, use cleaning solvent as lubricant,



1) Soapy water

**Fig. 20-2-4**

- 1) When installing the glass-and-weatherstrip assembly to the window panel (body), previously fit a cord into the weatherstrip's body flange channel.
- 1) Start the installation from the central bottom portion of the glass.
- 1) Position the glass-and-weatherstrip assembly in the window panel (body) opening with a helper applying pressure by palm from the outside. Then, pull the weatherstrip over the flange with the cord to install the assembly into position.



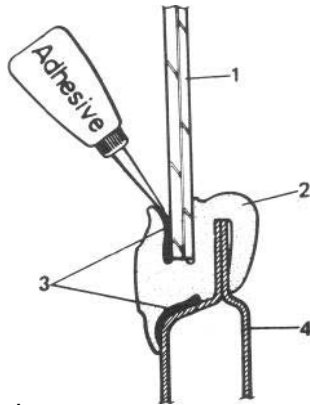
**Fig. 20-2-5**

- 1) To settle the glass in place, tap it by palm from the outside.
- 6) As for the bonding agent, use urethan-based bonding agent having the strength as shown below:

Separating Strength	At least 6 kg/1/2 in wide
Shearing Strength	At least 10 kg/cm <sup>2</sup>

7) Fill bonding agent completely between the glass and the weatherstrip and also between the window panel (body) and the weatherstrip.

To confirm this condition, bonding agent should be oozed out of position.



- 1. Windshield glass
- 2. Windshield weatherstrip
- 3. Adhesive
- 4. Window panel (body)

**Fig. 20-2-6**

**CAUTION:**

- 1 Bonding agent should be of the type which conforms to the material of the weatherstrip, having the above-mentioned strength. Also it must not affect the painted surface, weatherstrip or glass.
- 1 Until when the bonding agent is so completely dried that its strength can be obtained sufficiently, the relevant vehicle should not be driven. As for the drying time, follow the direction suggested by the manufacturer of the relevant bonding agent.

8) Oozed bonding agent should be wiped and cleaned with solvent completely.

### 20-3. BACK DOOR (APPLICABLE TO HARD TOP VEHICLE)

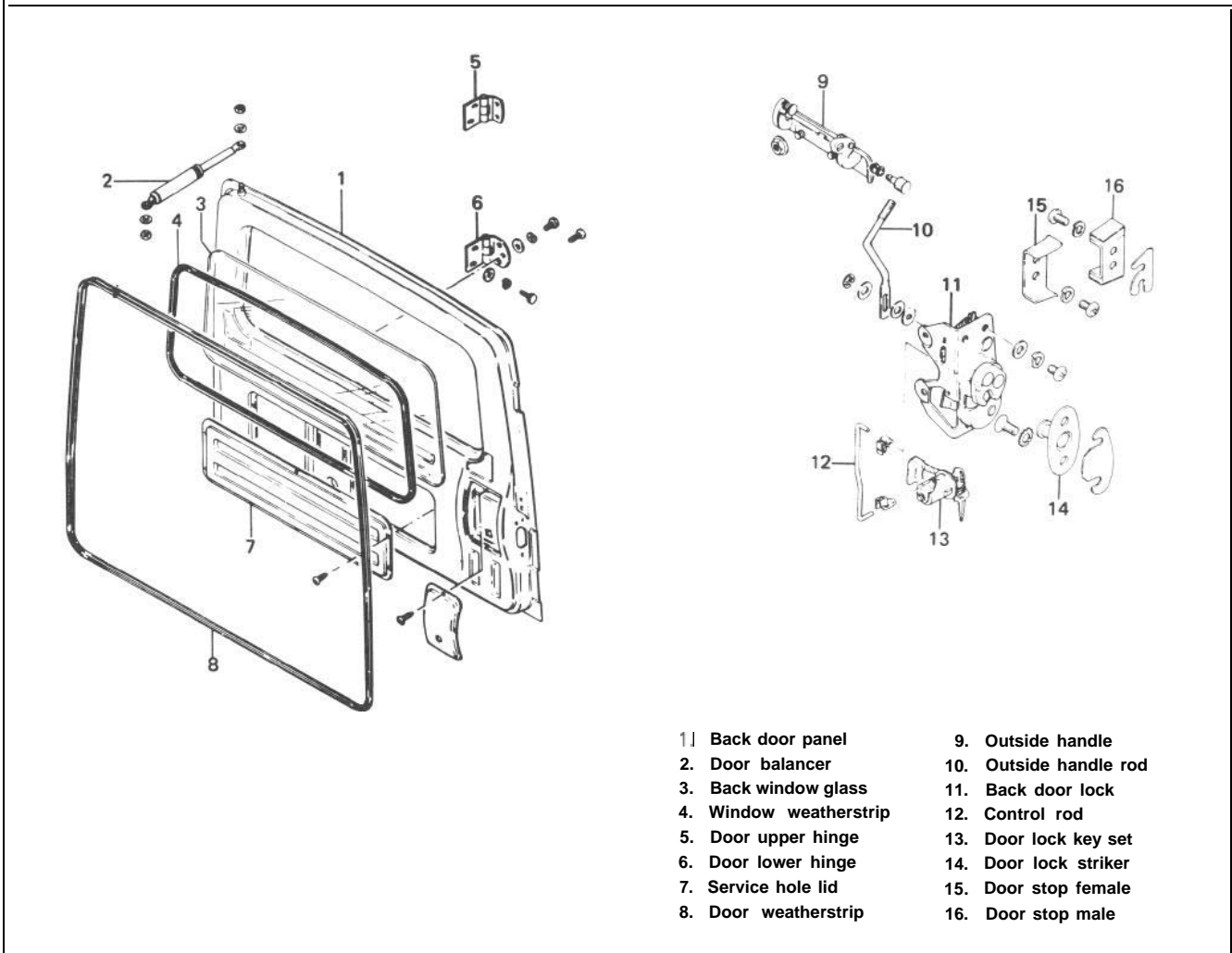


Fig. 20-3-1

#### DOOR LOCK AND STRICKER ADJUSTMENT Door Outside Open Rod

When installing open rod ② onto outside open handle ①, adjust clearances "A" to 0 – 2 mm (0 – 0.079 in) and "B" to 2 mm (0.079 in) as shown in Fig. 20-3-2 by turning adjusting joint ③.

**NOTE:**

Don't push down push plate (4) when installing the rod.

After installing the open rod, give the outside handle a trial and check if its play felt then is appropriate.

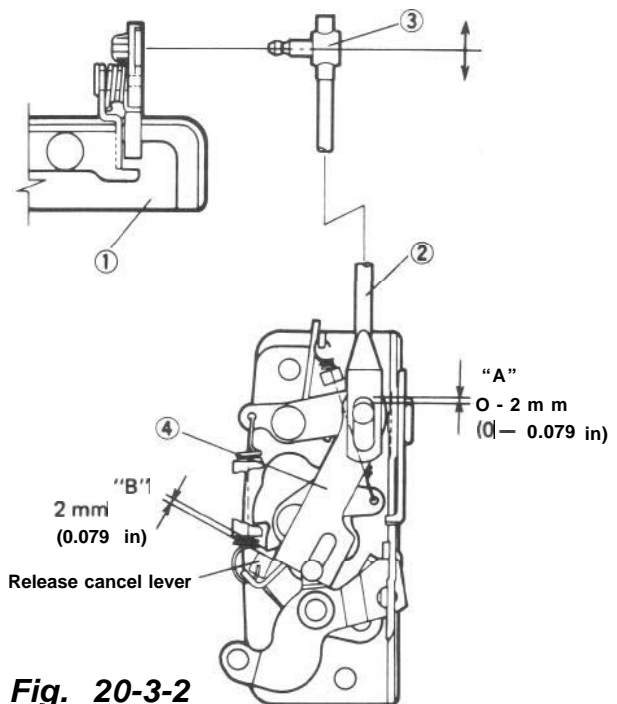


Fig. 20-3-2

### Door Lock Stricker

After reinstalling the door lock striker or door lock which was once removed, adjust dimension "C" in Fig. 20-3-3 to 1.0 mm (0.04 in) by moving the striker up and down.

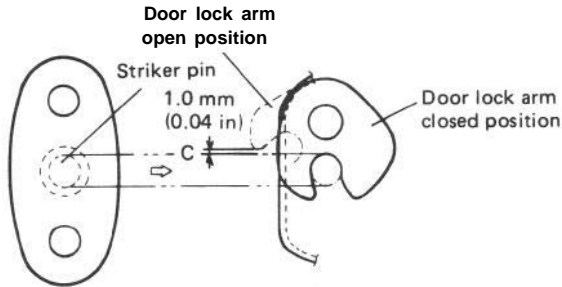


Fig. 20-3-3

To position the door lock striker correctly in the front and rear direction, adjust dimension "D" to 5.5 mm (0.22 in) as shown in Fig. 20-3-4 by increasing or decreasing spacers fitted in "E" position behind the striker.

After adjustment, check the difference in level between the door and body and adjust when there is a difference by moving the door lock striker to right or left.

**CAUTION:**  
Do not adjust the door lock.

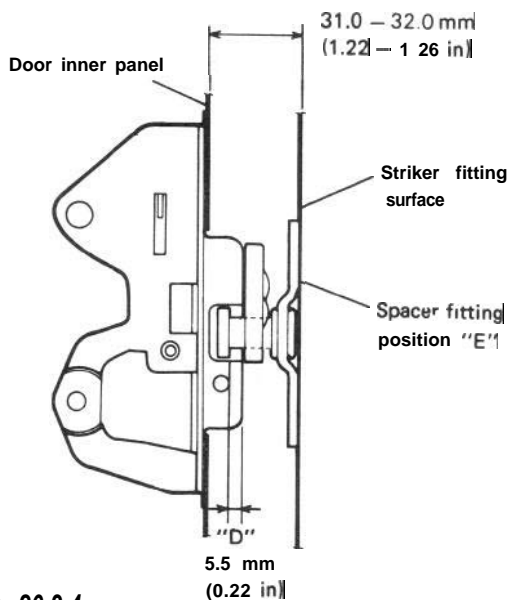


Fig. 20-3-4

### Handling of Back Door Balancer.

#### WARNING:

- 1 Handle the balancer carefully. Do not scar or scratch the exposed surface of its piston rod, and never allow any paint or oil to stick to the surface.
- 1 Do not disassemble the balancer because its cylinder is filled with high pressure gas.
- 1 Do not put it into the fire.
- 1 Do not store it where it gets hot.
- 1 When discarding the removed back door balancer, envelop it, as illustrated, with a vinyl bag. Then, use a 2 to 3 mm (0.08 to 0.12 in) drill to make a hole, as shown, from above through the bag into the balancer and let gas out.

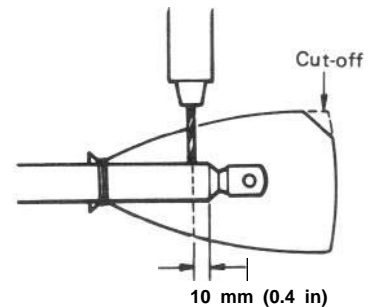
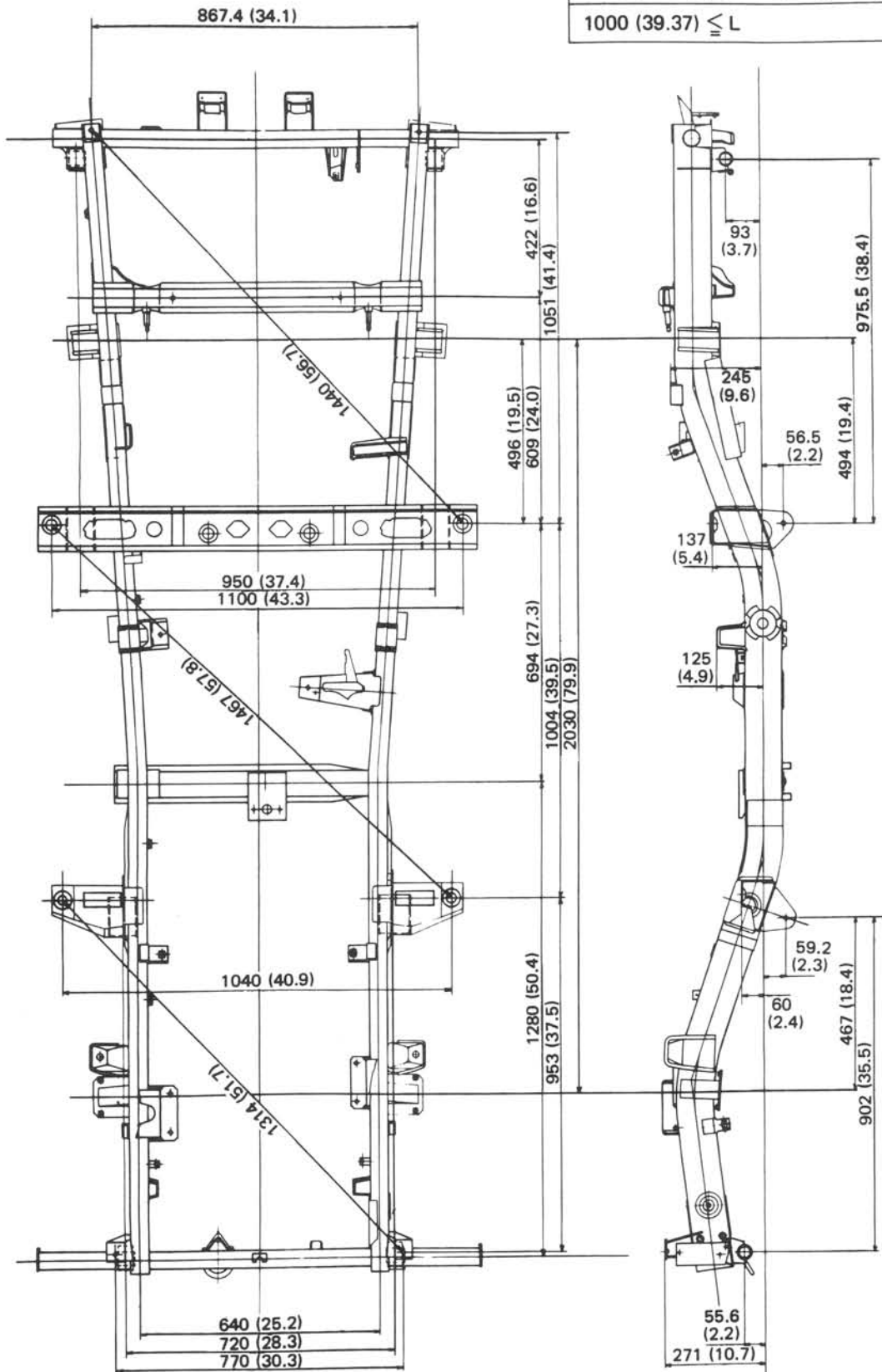


Fig. 20-3-5

## 20-4. CHASSIS DIMENSIONS

Unit: mm (in)

Dimension	Tolerance
$L < 100$ (3.94)	$\pm 2$ (0.079)
$100 (3.94) \leq L < 1000$ (39.37)	$\pm 3$ (0.118)
$1000 (39.37) \leq L$	$\pm 4$ (0.157)



## SECTION 21

# BODY ELECTRICAL EQUIPMENT

### CONTENTS

21-1.	COMBINATION METER .....	21-2
21-2.	HEAD LIGHT .....	21-4
21-3.	TURN SIGNAL LIGHT AND HAZARD WARNING LIGHT.....	21-7
21-4.	WINDSHIELD WIPER MOTOR .....	21-9
21-5.	WATER TEMPERATURE METER AND GAUGE.....	21-11
21-6.	FUEL LEVEL METER AND GAUGE .....	21-12
21-7.	BRAKE WARNING LAMP .....	21-13
21-8.	OIL PRESSURE LAMP .....	21-14
21-9.	4 WHEEL DRIVE LAMP .....	21-15
21-10.	SEAT BELT WARNING LAMP/BUZZER .....	21-15
21-11.	MAIN SWITCH KEY WARNING BUZZER.....	21-16
21-12.	ILUMINATION CONTROLLER.....	21-16
21-13.	REAR DEFOGGER ( hard-top ).....	21-16
21-14.	FUSE BOX.....	21-18
21-15.	WIRING HARNESS ROUTING .....	21-19
21-16.	WIRING DIAGRAM .....	21-22

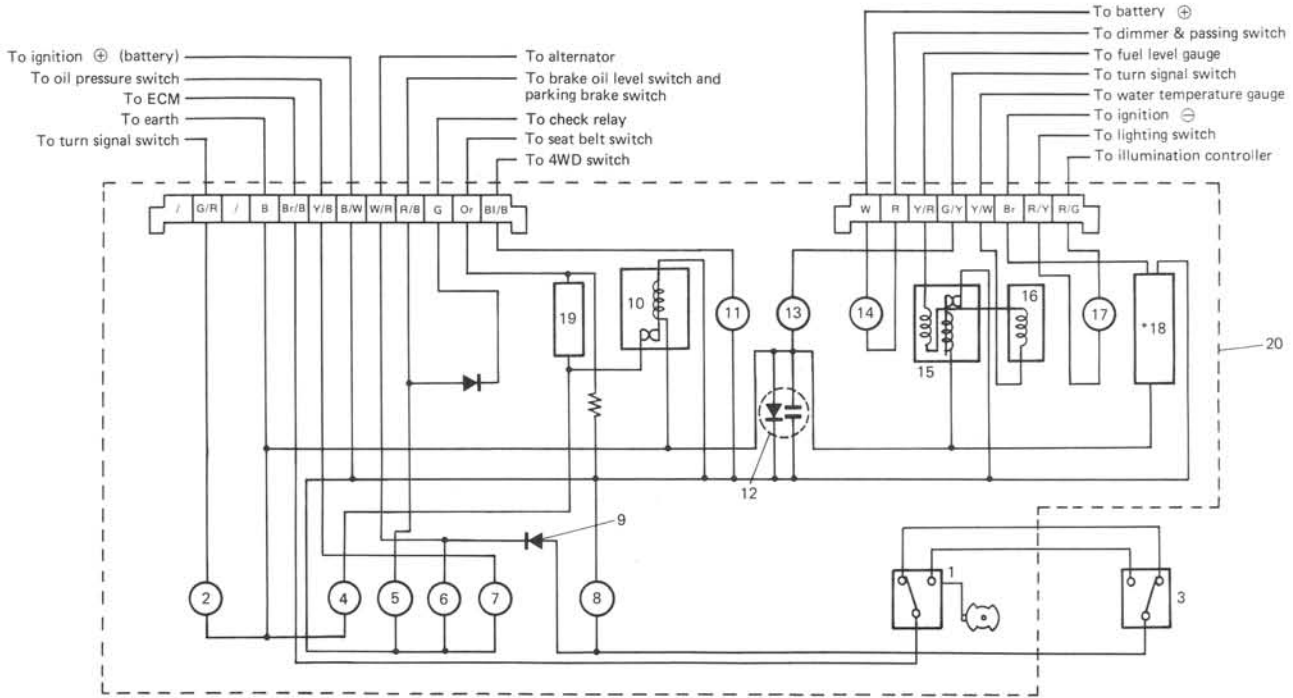
# 21-1. COMBINATION METER

## COMBINATION METER CIRCUIT AND COMPONENTS

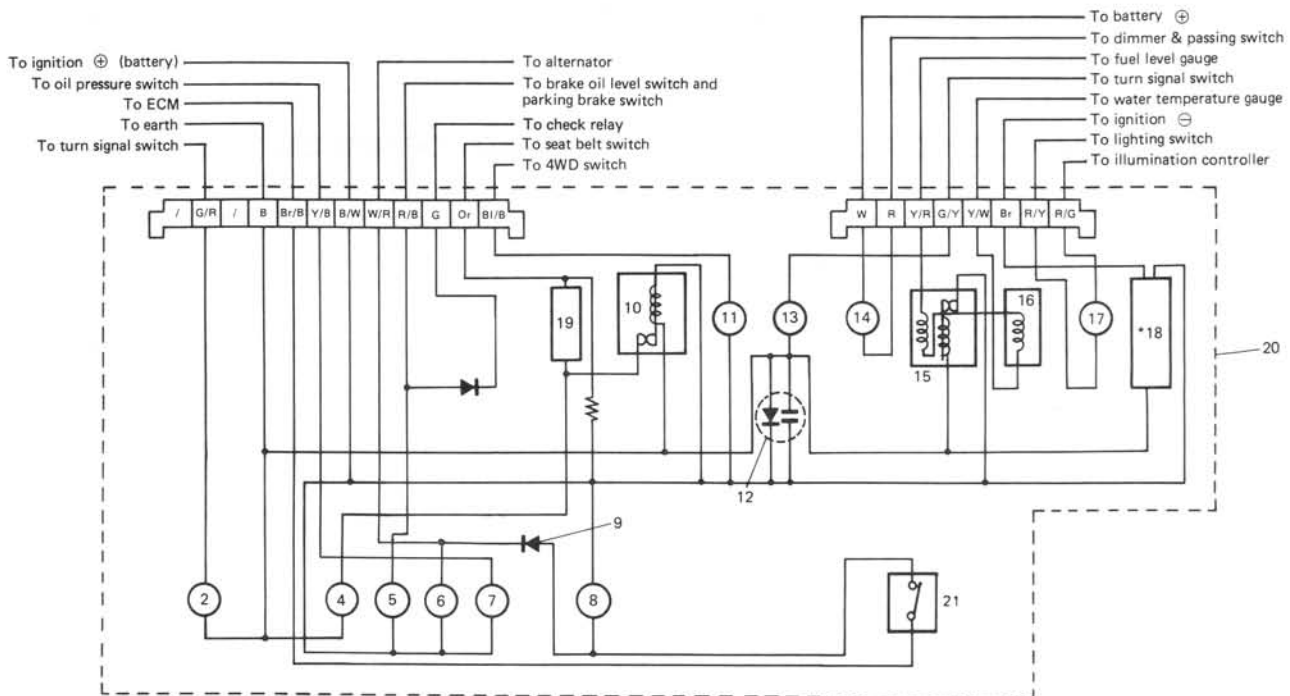
### NOTE:

Whether equipped with \* marked parts or not depends on vehicle specifications.

[U.S.A. specification vehicle]



[Canadian specification vehicle]



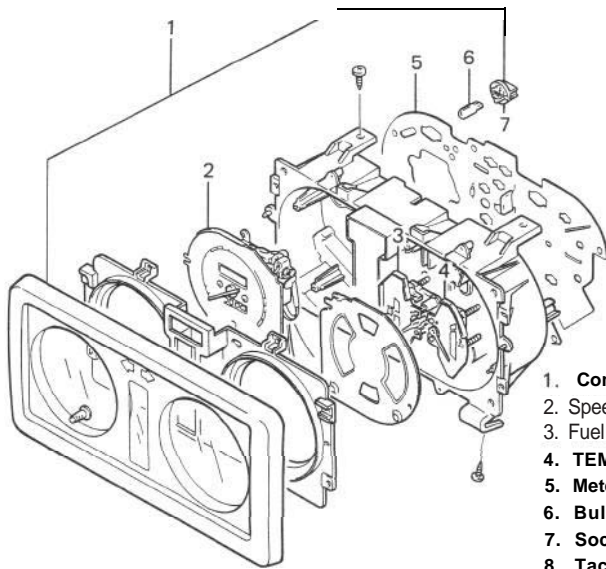


**Wire color**

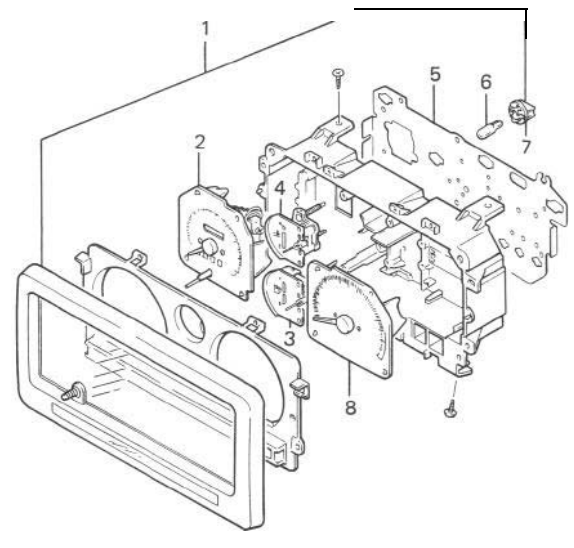
G/R . . . Green/Red	Or . . . Orange
B . . . . . Black	B1/B . Blue/Black
Br/B . . . Brown/Black	w . . . White
Y/B . . . Yellow/Black	Y/R . Yellow/Red
B/W . . . Black/White	G/Y . . Green/Yellow
W/R . . . White/Red	Y/W . . Yellow/White
R/B . . . Red/Black	R/Y . Red/Yellow
G . . . . . Green	R/G . . . Red/Green

- |  |                                 |
|--|---------------------------------|
| 1. 50,000 mile, 80,000 mile and 100,000 mile sensor switch | 11. 4WD light                   |
| 2. Turn signal pilot light (L)                             | 12. Noise'suppressor            |
| 3. Cancel switch   | 13. Turn signal pilot light (R) |
| 4. Seat belt warning light                                 | 14. Beam pilot light            |
| 5. Brake oil level warning light and parking brake light   | 15. Fuel level meter            |
| 6. Charge light"   | 16. Temp. meter                 |
| 7. Engine oil pressure light                               | 17. Illumination light          |
| 8. "CHECK ENGINE" light                                    | 18. Tachometer                  |
| 9. Diode   | 19. Seat belt warning buzzer    |
| 10. Seat belt relay  | 20. Combination meter           |
|  | 21. Check switch                |

**[Combination meter without tachometer]**



**[Combination meter with tachometer]**

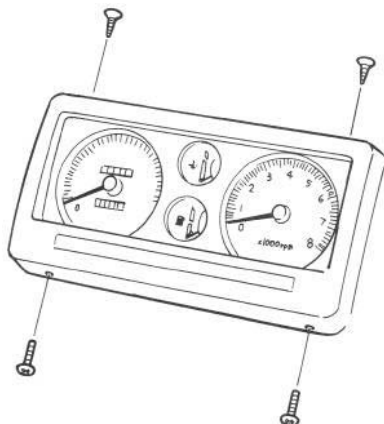


**Fig. 21-1**

**REMOVAL AND INSTALLATION**

1. Disconnect battery negative cable.
2. Remove instrument lower panel.
3. Lower steering column.
4. Remove combination meter cover.
5. Disconnect speedometer cable and wire harness coupler.
6. Remove combination meter.

7. To install combination meter, reverse above removal procedure.



**Fig. 21-2**

## 21-2. HEAD LIGHT WIRING CIRCUIT

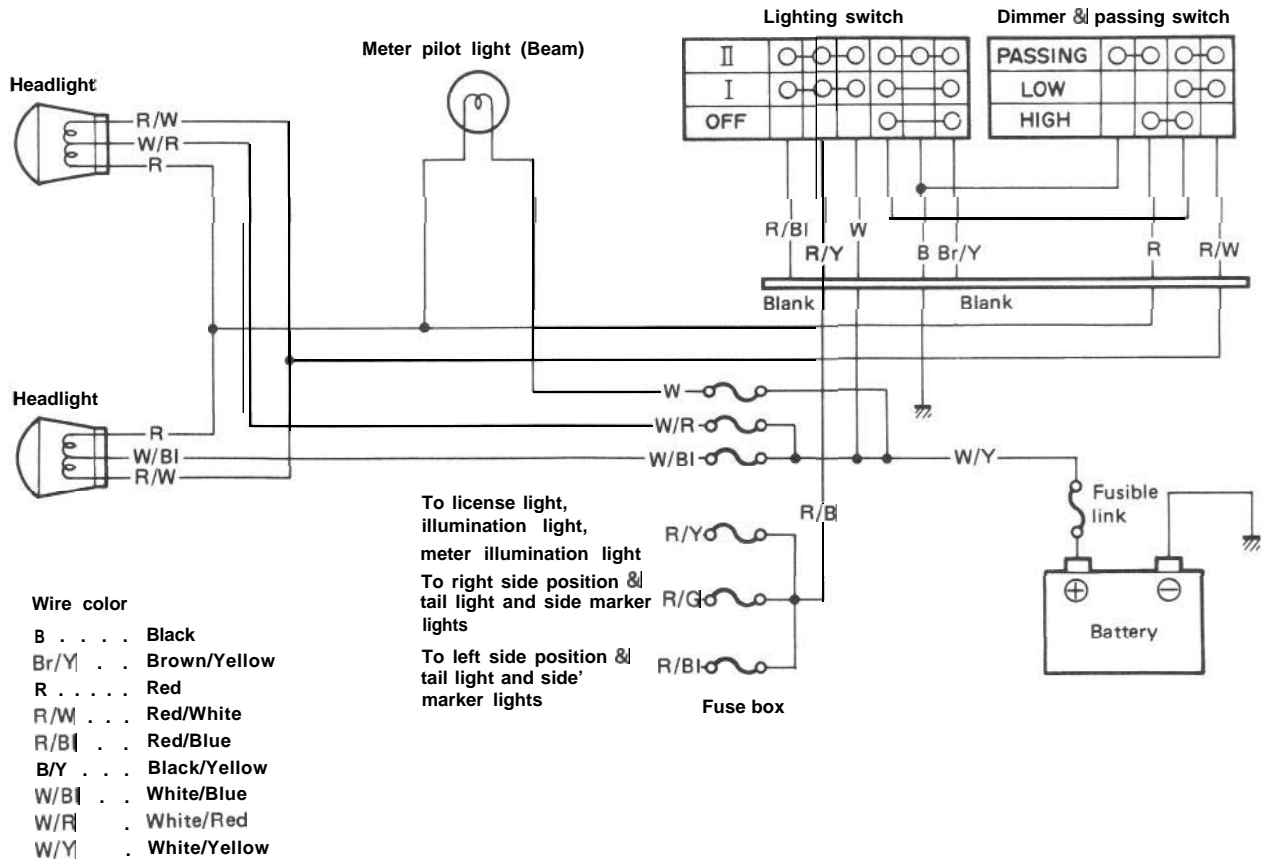


Fig. 21-3

**HEADLIGHT INSPECTION**

1. Lighting (Low beam, High beam, Passing)
2. Mounting
3. Dirt and cracks on lenses
4. Main beam axis direction and brightness

**HEADLIGHT BEAM SETTING (STANDARD PROCEDURE)**

Before setting the headlight beams, adjust air pressures of four tires to a specified value respectively. Move the vehicle up and down by hand to settle its attitude. Then move it over a flat surface. There are available a variety of headlight beams setting methods (e.g., the screen method using a focusing tester, etc.). However, the method described here does not use such tester.

**Beam alignment**

Unless otherwise obligated by the local regulations, align the headlight beams according to the following procedure. Place a blank wall 7.6 m (25 ft) ahead of the headlight. Check to see if the hot spot (high intensity zone) of each main (low) beam axis falls as illustrated below. The beam alignment should be carried out with one driver (68 kg, 150 lb) aboard.

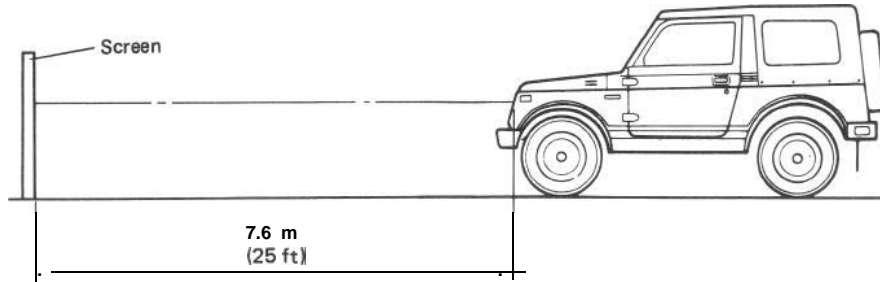
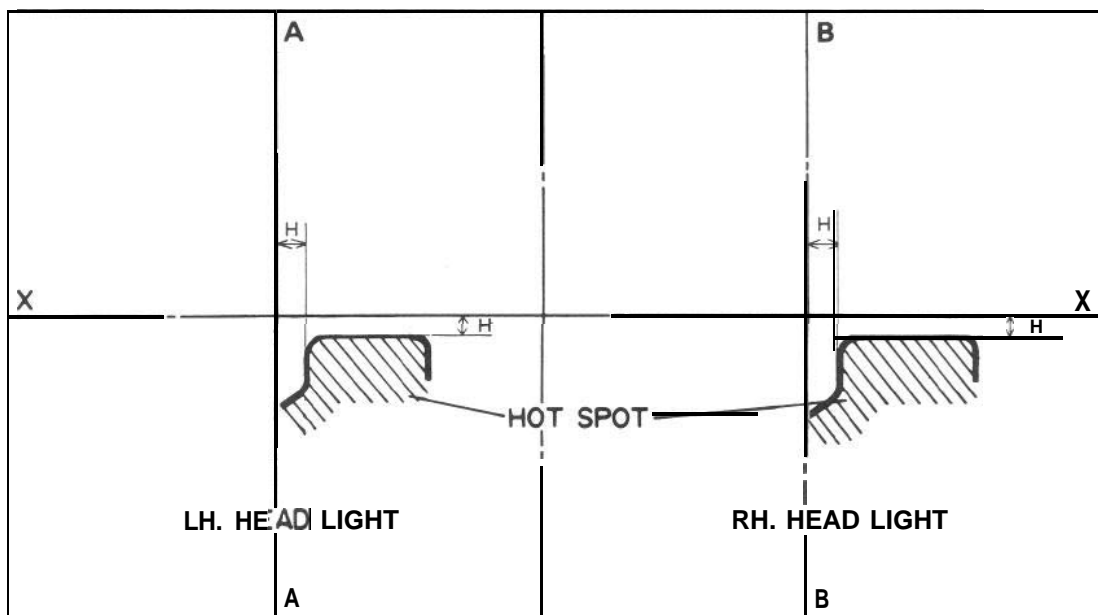


Fig. 21-4



X — X : Horizontal center line of headlights  
 A — A : Vertical center line of left headlight  
 B — B : Vertical center line of right headlight  
 H : 25 mm (0.98 in.)

Fig. 21-5

**MAINTENANCE**

**(1) Headlight adjustment**

There are two screws (1) and (2) which can be used for adjustment. Use these screws to adjust the headlight position for the vertical and horizontal alignment of each beam.

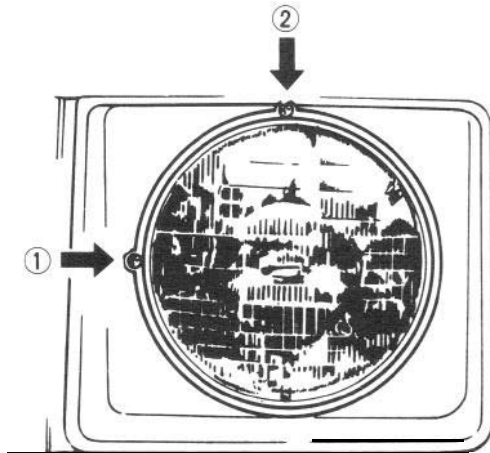
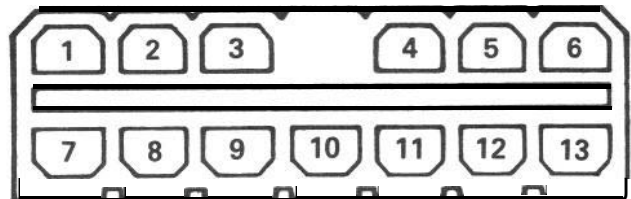


Fig. 21-6

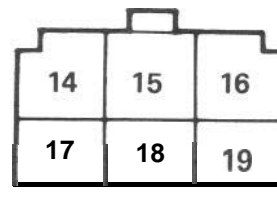
**(2) Head light dimmer switch**

Using circuit tester, check each circuit for continuity by putting tester probe pins to the terminals shown in Fig. 21-7. With switch kept in LOW BEAM position, tester should indicate continuity between terminals (7) and (18). Similarly, there should be continuity between terminals (8) and (18) when in HIGH BEAM position.

**Switch connector**



- |                            |                  |
|----------------------------|------------------|
| 1. Green/Red (Green/Black) | 8. Red           |
| 2. Green/Yellow            | 9. Blue/Green    |
| 3. Green                   | 10. Brown/Yellow |
| 4. Yellow                  | 11. Red/Blue     |
| 5. White/Blue              | 12. Red/Yellow   |
| 6. Yellow/Blue             | 13. White        |
| 7. Red/White               |                  |



- |                  |                |
|------------------|----------------|
| 14. Yellow/White | 17. Blue/Black |
| 15. Blue         | 18. Black      |
| 16. Blue/Red     | 19. Blue/White |

Fig. 21-7

**Combination switch (Lighting switch circuit)**

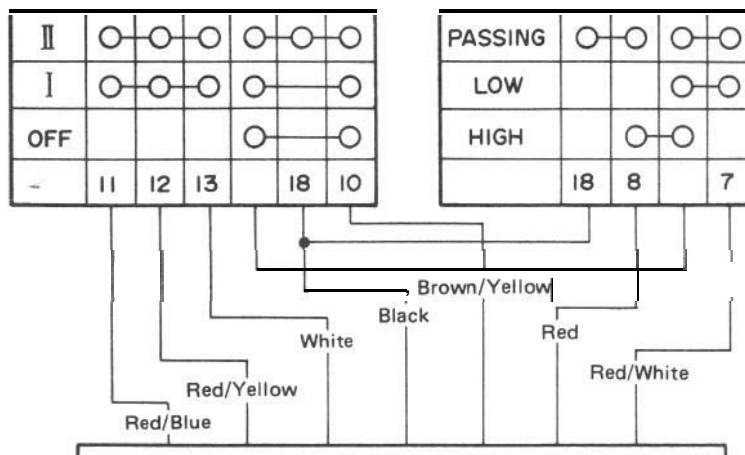
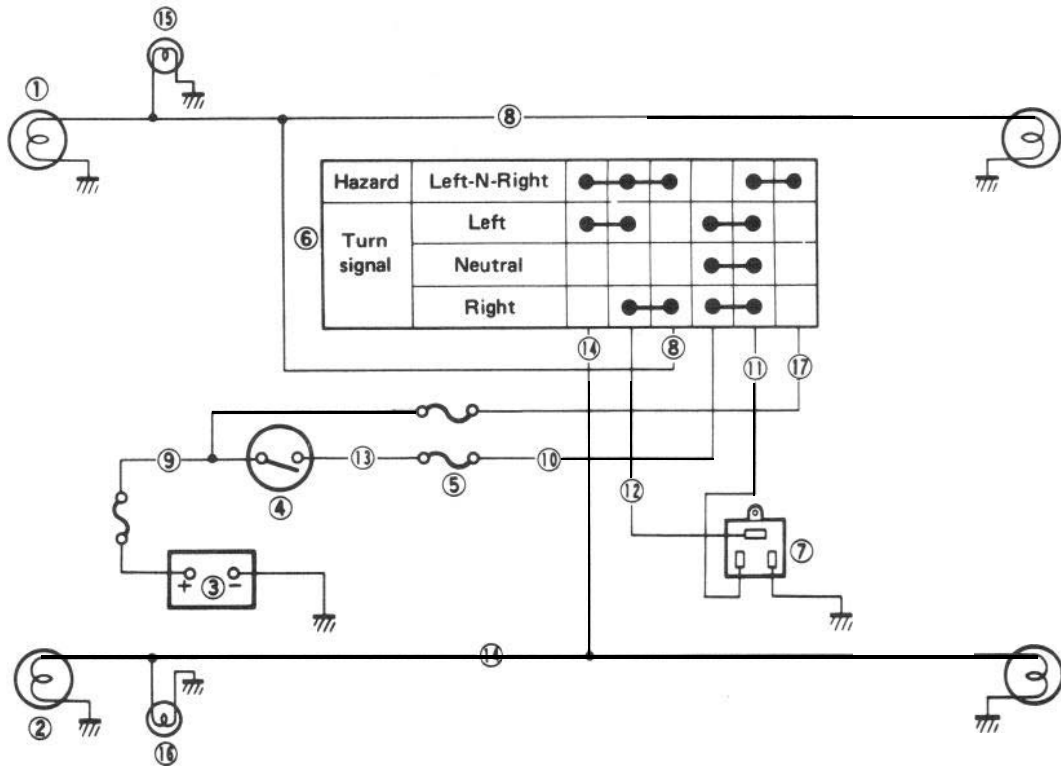


Fig. 27-8

### 21-3. TURN SIGNAL LIGHT AND HAZARD WARNING LIGHT CIRCUIT DESCRIPTION



- |  |                 |                               |
|--|-----------------|-------------------------------|
| 1. Right turn signal                     | 8. Green/Yellow | 15. Meter pilot light (Right) |
| 2. Left turn signal                      | 9. White/Yellow | 16. Meter pilot light (Left)  |
| 3. Battery                               | 10. Yellow      | 17. White/Green               |
| 4. Main switch                           | 11. Yellow/Blue |                               |
| 5. Fuse                                  | 12. Green       |                               |
| 6. Turn signal and hazard warning switch | 13. Black/Blue  |                               |
| 7. Turn signal and hazard warning relay  | 14. Green/Red   |                               |

**Fig. 21-9**

When hazard warning switch is "OFF", Yellow lead ⑩ is connected to Yellow/Blue lead ⑪ |  
 When the hazard warning switch is "ON", White/Green lead ⑰ is connected to Yellow/Blue lead ⑪ | and  
 Green lead (12) to both Green/Yellow lead ⑧ | and Green/Red lead ⑭ |  
 When Turn-signal switch is "ON" for right turn, Green lead ⑫ is connected to Green/Yellow lead ⑧ |  
 When Turn-signal switch is "ON" for left turn, Green lead ⑫ is connected to Green/Red lead ⑭ |

## INSPECTION

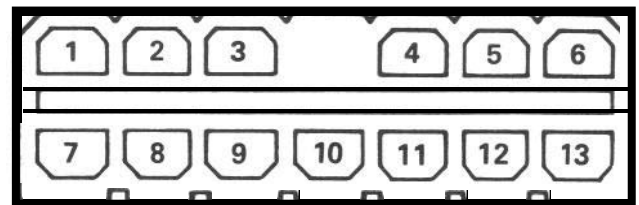
### 1) Trouble diagnosis

Symptom	Possible cause
1. Lights will not come on in either left or right group of light. 2. Hazard light comes on but turn signal lights will not. 3. No light comes on; or lights light up but do not flicker. 4. Turn signal lights are satisfactory, but hazard light will not come on. 5. Flickering frequency is erratic, or lights remain lit. 6. Turning on hazard warning switch lights up only one group of lights.	Fusible link is blown off.  Open circuit (due to poor point contact) in turn signal dimmer switch. Defective relay unit.  Open circuit in hazard warning switch.  Light bulbs are defective or improperly grounded.  Defective contact in dimmer switch.

### 2) Turn signal switch

Using circuit tester, check for continuity between each pair of terminals by referring to the chart given below and figure at the right for each position of turn signal switch lever. Discontinuity means that contact points are burnt or otherwise defective in the switch. For example, switch is in sound condition if continuity is noted between terminals 2 and 3, with lever in right-turn position, and between terminals 1 and 3, with lever in left-turn position.

Switch connector



- |                            |                  |
|----------------------------|------------------|
| 1) Green/Red (Green/Black) | 8. Red           |
| 2. Green/Yellow            | 9. Blue/Green    |
| 3. Green                   | 10. Brown/Yellow |
| 4. Yellow                  | 11. Red/Blue     |
| 5. White/Blue              | 12. Red/Yellow   |
| 6. Yellow/Blue             | 13. White        |
| 7. Red/White               |                  |

Fig. 21-10

### 3) Hazard warning switch

Disconnect, lead wire of the hazard warning switch at its coupler. Set switch to ON position and check for continuity with circuit tester between each of the following pairs of terminals; 2 and 3, 1 and 3, 5 and 6 among those shown in Fig. 21-10. The switch is in sound condition if continuity is noted between each pair.

### Turn signal & hazard warning switch

		1 (Green/Red or Green/Black)	3 (Green)	2 (Green/Yellow)	4 (Yellow)	6 (Yellow/Blue)	5 (White/Blue)
Hazard warning	Left-N-Right	●	●	●		●	●
Turn signal	Left	●	●		●	●	
	Neutral				●	●	
	Right		●	●	●	●	

## 21-4. WINDSHIELD WIPER MOTOR

### CIRCUIT DESCRIPTION

The circuit is designed so that, when the Wiper Switch is turned “OFF”, the blade will automatically return to the horizontal position. In Fig. 21-11, when the Wiper Switch is turned “ON” while the Main Switch is “ON”, current is supplied to the Wiper Motor from the Battery, the motor rotates and the blade moves. The gear mechanism which converts rotational movement of the motor into swinging movement of the blade has a cam on the final gear shaft. The cam switches the contacts of P0 and P2 every revolution. (At the blade stop position, the contact is switched from P2 to P1.)

Repeated contact making and breaking is independent of the wiper motor rotation. When the Wiper Switch is turned “OFF” while the blade is in a position other than the rest position, motor current path is changed (i.e. BI/W → BI → MOTOR). Therefore, the motor keeps rotating even though the wiper switch is turned “OFF”, and the blade will return to the rest position.

When the blade returns to the rest position, the cam contact is changed from P2 to P1 and motor current is shunted. When supply to the motor is cut off, a counter electromotive force is generated in the armature. As a result of this counter electromotive force, current flows through the motor and shunt circuit and the motor stops and the wiper blade stays in the specified position.

### [INTERVAL WIPER RELAY CIRCUIT (OPTIONAL)]

When the wiper switch is set to the interval position with the ignition switch ON (the condenser is charged at this time), current from the battery flows through the yellow/blue wire, generates magnetic force in the coil in the relay and causes the switch in the relay to turn ON. Then current is transmitted in the sequence of yellow/blue, relay, wiper switch and blue and causes the wiper motor to rotate (meanwhile, the condenser discharges). By the time the wiper motor makes one rotation and the cam in the motor comes to the automatic stop position P1, the condenser in the relay has finished discharging (no magnetic force in the coil in the relay). Then the switch in the relay turns OFF and the wiper stops. They remain that way until the condenser is fully charged. As soon as the condenser begins discharging after being fully charged, magnetic force generated in the coil in the relay causes the switch to turn ON. As described above, interval operation of the wiper motor is controlled by charging and discharging of the condenser.

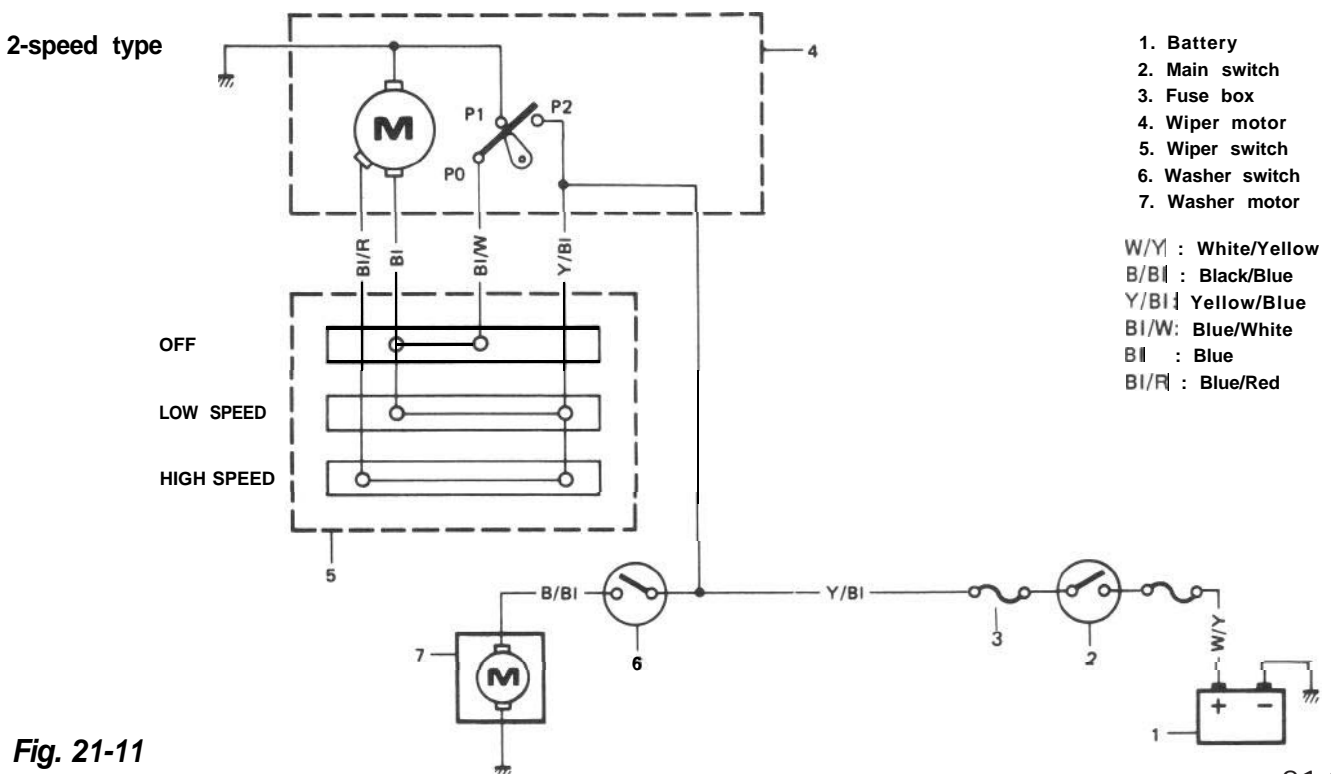


Fig. 21-11



### 3-speed type

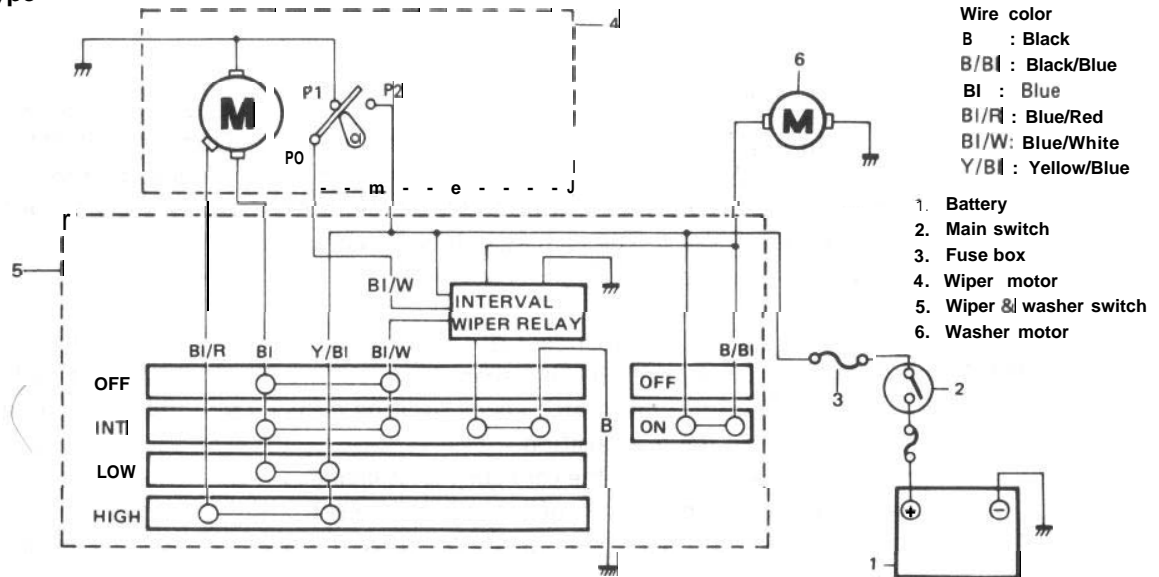


Fig. 21-12

### MAINTENANCE

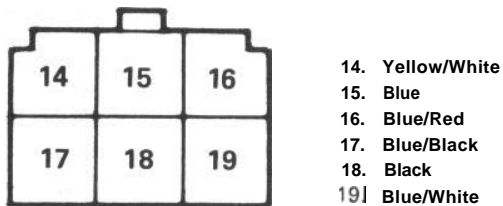
#### 1) Wiper trouble diagnosis

When wiper motor does not start even if Wiper Switch is turned "ON", check lead connections and coupler connections. Then, check the following.

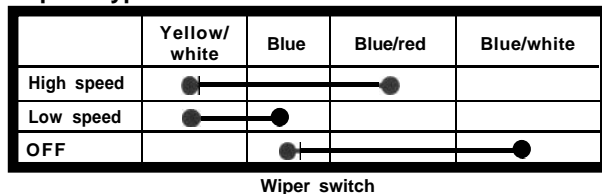
- Fuse blown or mounted incorrectly.
- Wiper switch:

To check wiper switch: remove couplers and check continuity between following terminals by using circuit tester.

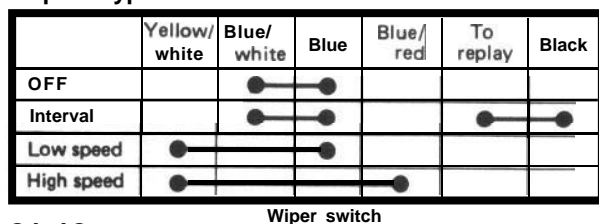
#### Switch connector



### 2-speed type



### 3-speed type



#### c) Break in wiper motor armature or poor commutator brush contact:

To check these, check continuity between Blue lead and ground, and Blue/Red wire and ground respectively.

#### 2) No-load run test

As shown in Fig. 21-13, using a 12V battery, connect positive battery terminal to Blue terminal and the negative terminal to motor. If motor rotates at 45 – 57 r/min, this is acceptable (for Low-speed check). For High-speed check, connect the positive terminal to Blue/Red terminal and negative terminal to motor. If motor rotates at 67 – 81 r/min, this is acceptable.

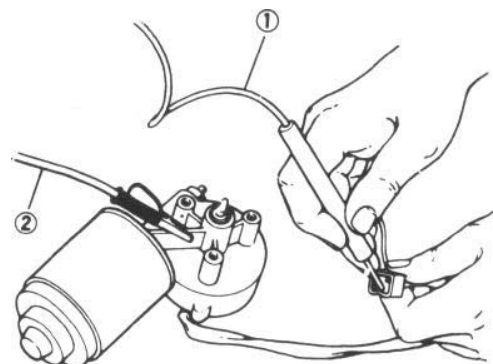


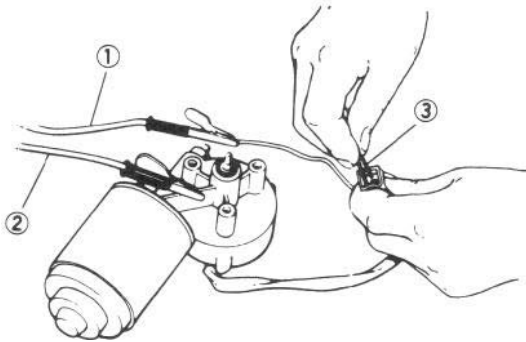
Fig. 21-13 Testing motor

- Positive terminal
- Negative terminal



### 3) Automatic stop action test

Connect yellow terminal of motor to positive (+) battery terminal, and put a jumper between Blue/White (Blue/Black) and Blue terminals to see if motor output shaft comes to a halt at a certain, not just any, angular position. That position corresponds to starting position of the blade. Using jumper, stop motor a number of times to make sure that motor stops at the same position each time.



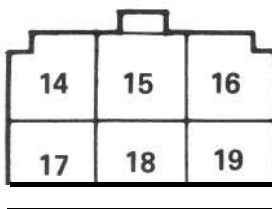
**Fig. 21-14 Testing motor**

1. Positive terminal
2. Negative terminal
3. Put a jumper between Blue/White (Blue/Black) and Blue

### 4) Internal wiper relay test

1. Disconnect wiper & washer switch coupler.
  2. Turn wiper switch to "I NT" position.
  3. Connect positive battery terminal to Yellow/White coupler terminal and negative battery terminal to Black terminal.
- If an operating sound is heard, the relay is at work properly.

Switch connector



14. Yellow/White
15. Blue
16. Blue/Red
17. Blue/Black
18. Black
19. Blue/White

**Fig. 21-15**

## 21-5. WATER TEMPERATURE METER AND GAUGE

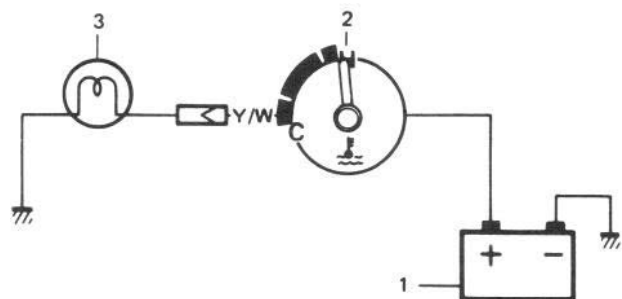
The water temperature meter is located in the combination meter and its gauge unit on the inlet manifold.

The gauge unit shows different resistance values depending on the coolant temperature. This causes a current flowing through the temperature meter coil to change, controlling the meter pointer. That is, when the coolant temperature is raised, the gauge unit resistance is decreased with more current flowing through the meter coil, raising the meter pointer upward from the "C" position.

### INSPECTION

[Water temperature meter]

1. Disconnect Y/W (Yellow/White) lead wire going to gauge unit installed to intake manifold.
  2. Use a bulb (12V 3.4W) in position to ground above wires as illustrated.
  3. Turn main switch ON, Confirm that the bulb is lighted and meter pointer fluctuates several seconds thereafter.
- If meter is faulty, replace it.



1. Battery
  2. Water temperature meter
  3. Test lamp (12V, 3.4W)
- YIW: Yellow/White

**Fig. 21-16**

[Gauge unit]

Warm up gauge unit. Thus make sure its resistance is decreased with increase of temperature. Temperature and resistance relationship can be plotted in a graph as shown below.

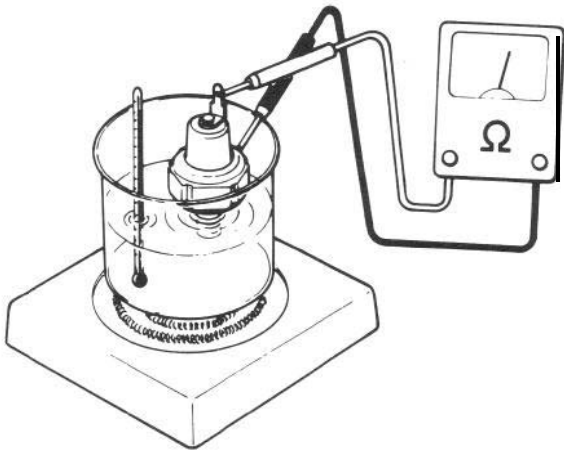


Fig. 21-17

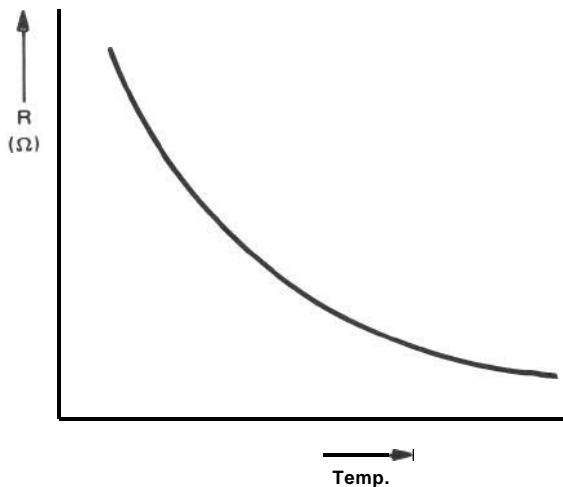


Fig. 21-18 Resistance- Temp. Relationship

Temperature	Resistance
50°C (122°F)	133.9 – 178.9 Ω
80°C (176°F)	47.5 – 56.8 Ω
100°C (212°F)	26.2 – 29.3 Ω

**NOTE:**

Wind sealing tape on screw threads of gauge before installing gauge to intake manifold.

## 21-6. FUEL LEVEL METER AND GAUGE

The fuel level meter circuit consists of the fuel level meter installed inside the combination meter and the fuel level gauge installed to the fuel tank.

Current flowing through the meter coil is changed to control the meter pointer. That is, when fuel is full, the fuel level gauge unit resistance is decreased with more current flowing into the meter coil, causing the meter pointer to point at the “F” position.

### INSPECTION

[Fuel level meter]

1. Disconnect Y/R (Yellow/Red) lead wire going to gauge unit.
2. Use a bulb (12V 3.4W) in position to ground above lead wire as illustrated.
3. Turn ignition switch ON.

Make sure the bulb is lighted and meter pointer fluctuates several seconds thereafter. If meter is faulty, replace it.

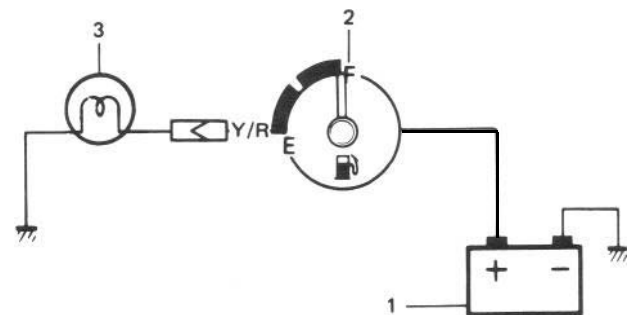


Fig. 21-19

1. Battery
  2. Fuel level meter
  3. Test lamp (12V, 3.4W)
- Y/R : Yellow/Red

[Gauge unit]

Use ohmmeter to confirm that level gauge unit changes in resistance with change of the float position. Float position-to-resistance relationship can be plotted in a graph as shown below.

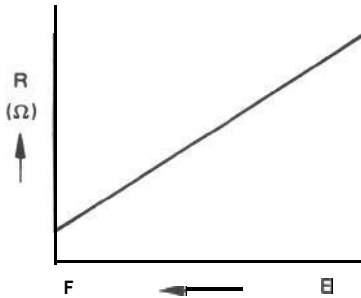
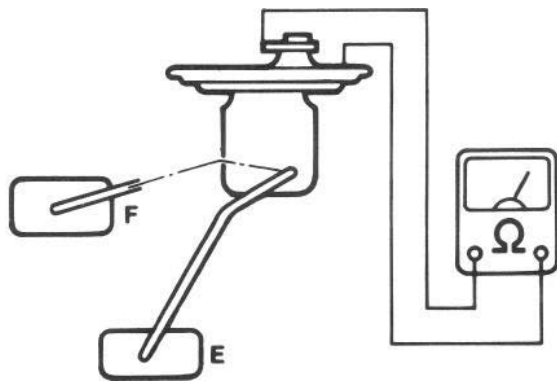


Fig. 21-20 Resistance-Fuel Level Relationship



F : Full  
E : Empty

Fig. 21-21

Position	Resistance
E	$110 \pm 7 \Omega$
F	$3 \pm 2 \Omega$
1/2	$32.5 \pm 4 \Omega$

## 21-7. BRAKE WARNING LAMP

The brake warning lamp system consists of the brake fluid level switch installed to the master cylinder reservoir and the lamp inside the combination meter.

This circuit includes a parking brake switch which gives a warning for unreleased parking brake.

### OPERATION

Brake fluid level warning lamp circuit consists of brake fluid level switch installed in master cylinder reservoir, brake fluid level warning lamp in gage cluster and check relay.

Also, this circuit is additionally provided with parking brake switch which warns that parking brake is applied. when engine is stopped, warning lamp comes on, if ignition switch is turned ON and parking brake is applied.

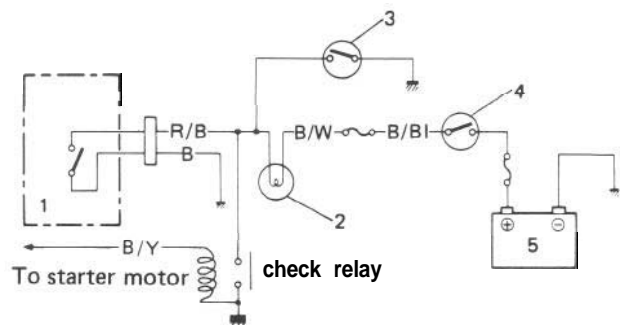
For bulb check, warning lamp comes on briefly during engine starting regardless of brake fluid level position and parking brake operation.

Because point of check relay is closed.

After engine is started, release parking brake.

If lamp goes off, brake fluid level is adequate.

When warning lamp does not operate, use circuit diagram as reference to check bulb, wiring, etc.



B/Y : Black/Yellow  
R/Bl : Red/Black  
B : Black  
B/W : Black/White  
B/Bl : Black/Blue

1) Fluid level switch  
2. Warning lamp  
3. Parking brake switch  
4. Main switch  
5. Battery

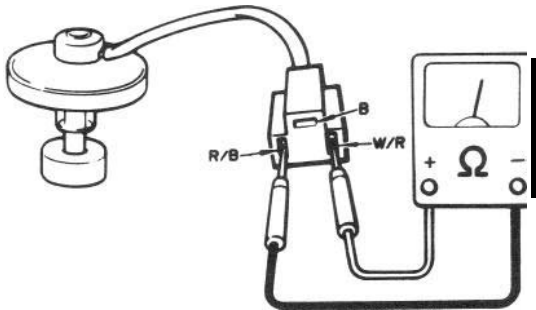
Fig. 27-22

**INSPECTION**

[Brake fluid level switch]

Use ohmmeter to check switch for resistance and continuity.

If found defective, replace switch.



**Fig. 21-23**

W/R : White/Red  
 B : Black  
 R/B : Red/Black

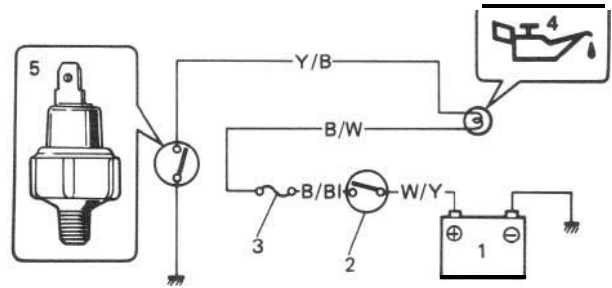
R/B – B Resistance	
OFF position (float up)	$\infty$
ON position (float down)	Several $\Omega$

R/B – W/R Continuity	
R/B to W/R	Continuity obtained
W/R to R/B	No continuity obtained

**21-8. OIL PRESSURE LAMP**

The oil pressure lamp circuit consists of the oil pressure switch installed to the cylinder block and the lamp (warning lamp) inside the combination meter.

The oil pressure switch so operates that it is switched OFF when oil pressure is produced by the started engine and then fed to switch.



- 1. Battery
- 2. Main switch
- 3. Fuse
- 4. Oil pressure lamp
- 5. Oil pressure switch

B/B : Black/Blue  
 B/W : Black/White  
 Y/B : Yellow/Black  
 W/Y : White/Yellow

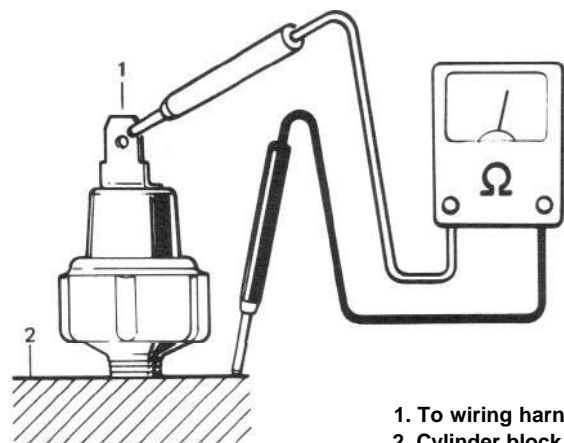
**Fig. 21-24**

**INSPECTION**

[Oil pressure switch]

Use a ohmmeter to check the switch continuity.

During engine Running	No continuity obtained ( $\infty \Omega$ )
At Engine Stop	Continuity obtained ( $0 \Omega$ )



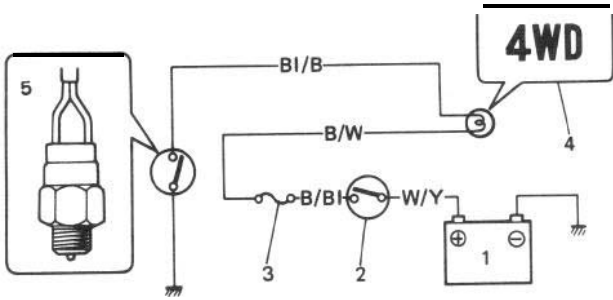
1. To wiring harness  
 2. Cylinder block

**Fig. 21-25**

### 21-9. 4 WHEEL DRIVE LAMP

The 4 wheel drive lamp circuit consists of the 4 wheel drive indicator lamp switch installed to the transfer and the lamp inside the combination meter.

The 4WD switch so operates that it is switched ON when transfer gear shift control lever is shifted to "4H" or "4L" position.



- 1. Battery
- 2. Main switch
- 3. Fuse
- 4. 4WD lamp
- 5. 4WD switch

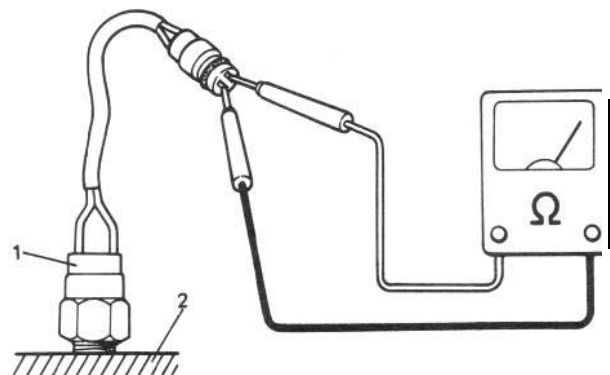
- B/B : Black/Blue
- B/W : Black/White
- BI/B : Blue/Black
- W/Y : White/Yellow

Fig. 21-26

### INSPECTION [4WD switch]

Use a ohmmeter to check the switch continuity.

"4H" on "4L" position	Continuity obtained (0 Ω)
"2H" on "N" position	No continuity obtained (∞ Ω)

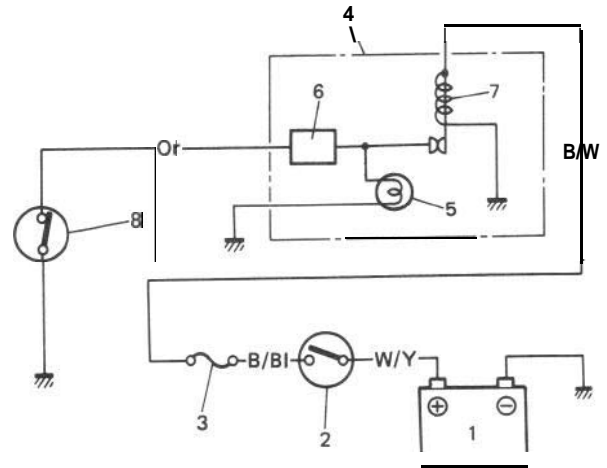


- 1. 4WD switch
- 2. Transfer

Fig. 21-27

### 21-10. SEAT BELT WARNING LAMP/ BUZZER

The seat belt warning lamp/buzzer circuit is a system to light and sound the lamp and buzzer respectively for several seconds, urging the driver to wear his seat belt. After several seconds passed, the lamp goes OFF and the buzzer stops sounding whether the seat belt is worn or not.



- 1. Battery
- 2. Main switch
- 3. Fuse
- 4. Combination meter
- 5. Warning lamp
- 6. Warning buzzer
- 7. Bi-metal
- 8. Warning switch

- W/Y : White/Yellow
- B/B : Black/Blue
- B/W : Black/White
- Or : Orange

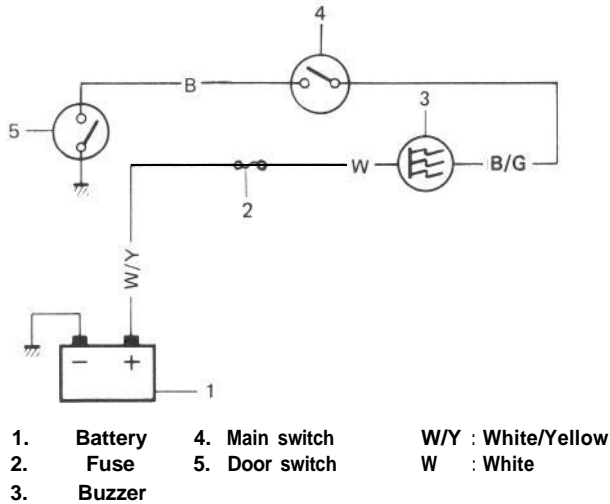
Fig. 21-28

### INSPECTION

When the warning lamp/buzzer do not make lighting/sounding, use the above Circuit Diagram as reference to check the bulb, buzzer, wiring, etc.

## 21-11. MAIN SWITCH KEY WARNING BUZZER

The main switch key warning buzzer circuit is a system to sound the buzzer if the driver leaves the car with the main switch key inserted in place, urging him to take it out of place.



**Fig. 21-29**

### INSPECTION

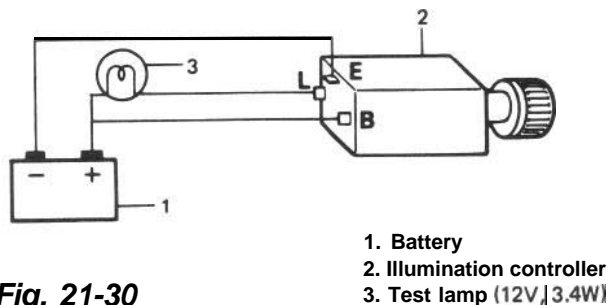
If the main switch key warning buzzer does not sound, use the above Wiring Diagram as reference to check the buzzer.

## 21-12. ILLUMINATION CONTROLLER

### INSPECTION

Use a test lamp to wire as illustrated below.

Make sure that the illumination controller knob is turned rightwise to brighten the test lamp, leftwise to darken it.

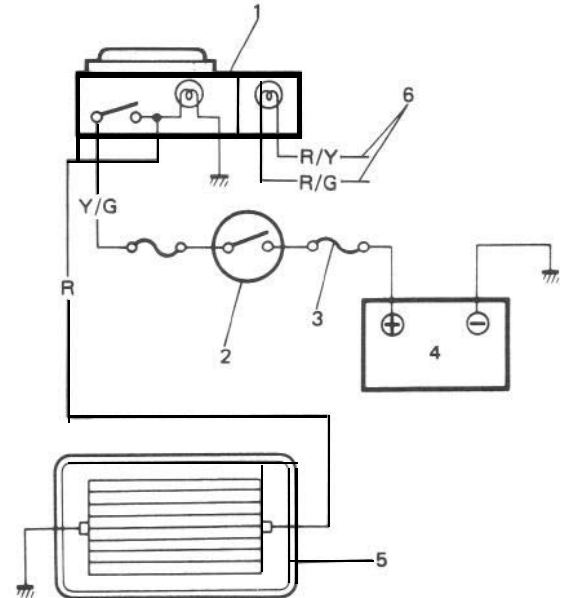


**Fig. 21-30**

1. Battery
2. Illumination controller
3. Test lamp (12V, 3.4W)

## 21-13. REAR DEFOGGER (OPTIONAL FOR HARD TOP MODEL)

The Defogger circuit for the rear window glass heating wires is as follows:

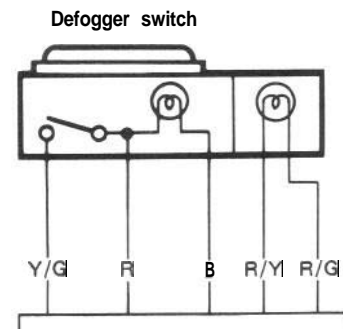


1. Defogger switch
2. Main switch
3. Fusible link
4. Battery
5. Rear window glass with embedded heating wire
6. To illumination controller

- Y/G : Yellow/Green  
 B : Black  
 R : Red  
 R/Y : Red/Yellow  
 R/G : Red/Green

**Fig. 21-31**

To check function of Defogger Switch, check continuity between Yellow/Green wire and Red wire when Defogger Switch is "ON"



**Fig. 21-32**

- Y/G : Yellow/Green  
 R : Red  
 B : Black  
 R/Y : Red/Yellow  
 R/G : Red/Green

## DEFOGGER WIRE

### NOTE:

- When cleaning the rear window glass, use a dry cloth to wipe it along the wire direction.
- When cleaning the glass, do not use detergent or abrasive-containing glass cleaner.
- When measuring wire voltage, use a tester with the negative probe wrapped with a tin foil which should be held down on the wire by finger pressure.

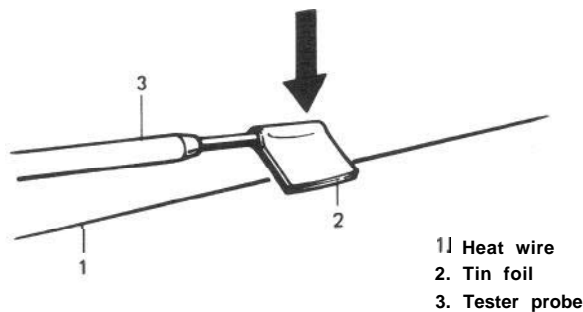


Fig. 21-33

### 1) Checking wire damage

- Turn the main switch ON.
- Turn the defogger switch ON.
- Use a voltmeter to check the voltage at the center of each heat wire, as illustrated.

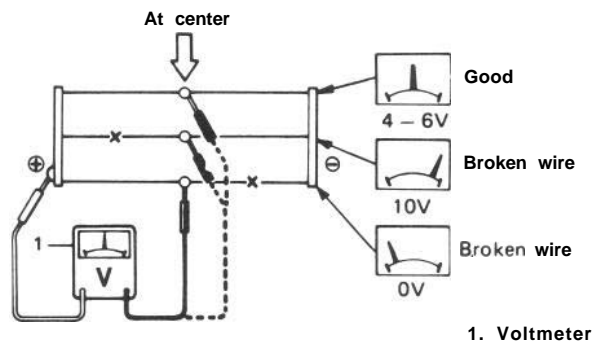


Fig. 21-34

Voltage	Criteria
Approx. 5V	Good (No break in wire)
Approx. 10V or 0V	Broken wire

If the obtained voltage is 10V, the wire must be damaged between its center and positive end. If the voltage is zero, the wire must be damaged between its center and earth.

### 2) Checking wire for damaged place

- Set the voltmeter positive (+) lead to the heat wire positive terminal end.

- Set the voltmeter negative (-) lead with a foil strip to the heat wire positive terminal end to then move it along the wire to the negative terminal end.
- The place which causes the voltmeter to fluctuate from zero to several volts is a damaged place.

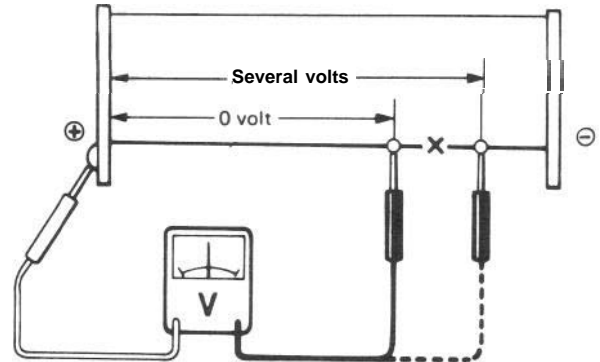


Fig. 21-35

### NOTE:

If the heat wire is free from damage, the voltmeter should point 12V at the heat wire positive terminal end with its indication gradually decreased toward zero to thus equal 0V at the other terminal (earth) end.

## REPAIR

### [Defogger circuit]

- Use white gasoline for cleaning.
- Apply a masking tape at both the upper and lower sides of a heat wire to be repaired.

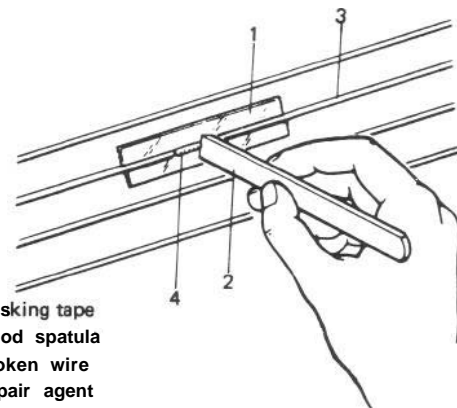


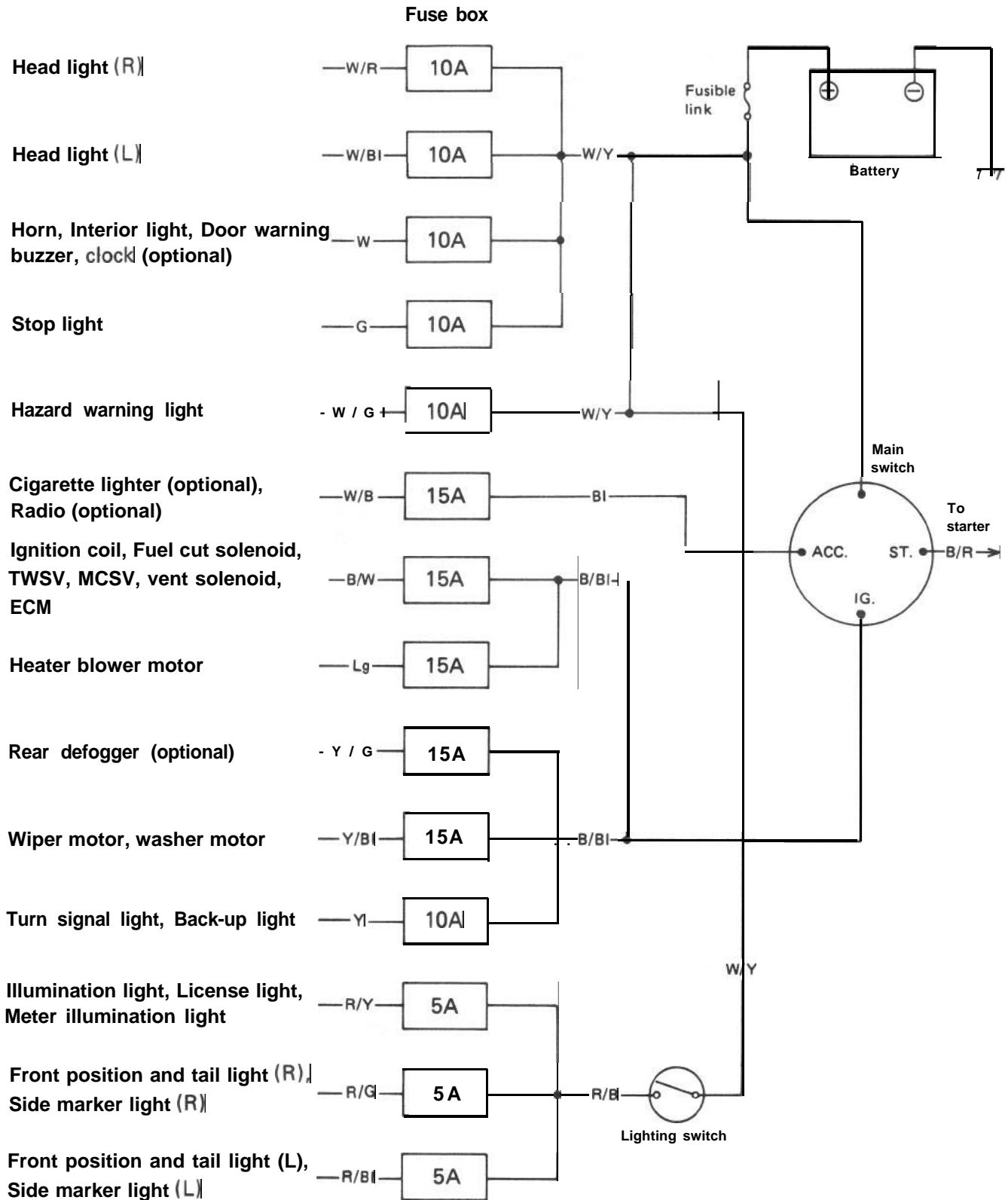
Fig. 21-36

- Apply commercially-available repair agent with a fine-tip brush.
- Two to three minutes later, remove the masking tapes previously applied.
- Leave the repaired heat wire as it is for at least 24 hours before operating the defogger again.



## 21-14. FUSE BOX

The fuses in the fuse box is wired as follows.



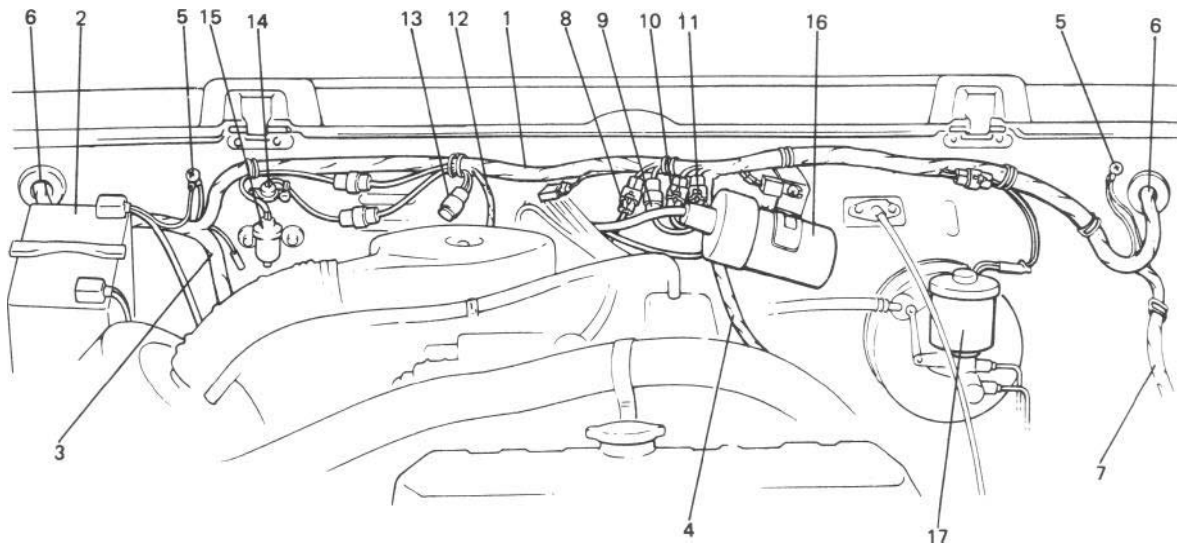


## 21-15. WIRING HARNESS ROUTING

When reinstalling wire harness, be careful for the following.

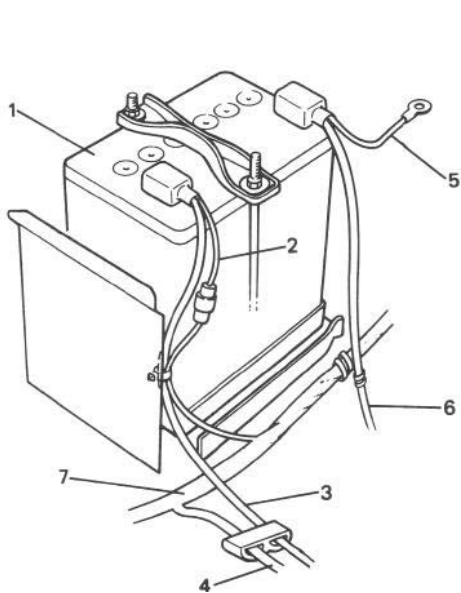
- 1 When doing wiring harness related work, make always sure to disconnect battery negative cable from battery.
- 1 Clamp wire harness securely at prescribed positions.
- 1 Try to route wire harness so as to avoid contact with other parts as much as possible. Use special care not to let it contact sharp edges of body or other parts.
- Connect connectors securely.

### Engine Room Wiring

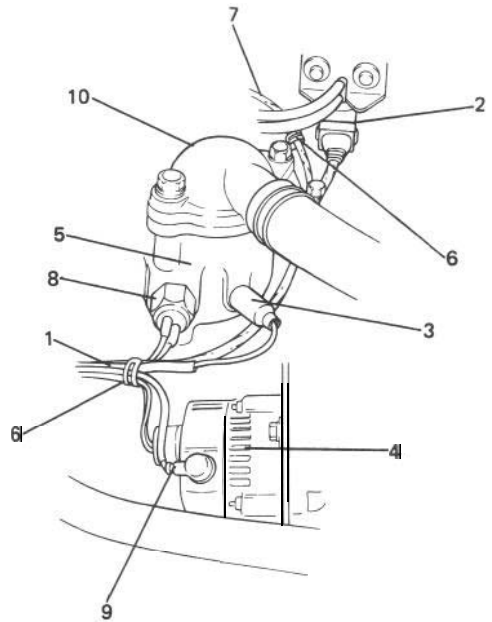


- |   |                                |
|---|--------------------------------|
| 1. Wire harness No. 2   | 12. To TWSV                    |
| 2. Battery  | 13. Duty check coupler         |
| 3. To starter, alternator, head light, small light, horn and etc. | 14. Thermal engine room switch |
| 4. To license light, stop/tail light, 4WD switch                  | 15. HAC                        |
| 5. Earth  | 16. Ignition coil              |
| 6. To wiring harness No. 1  | 17. Brake fluid reservoir      |
| 7. To head light, small light, etc.                               |                                |
| 8. To distributor   |                                |
| 9. To ignition coil   |                                |
| 10. To back up light switch                                       |                                |
| 11. To fifth switch   |                                |

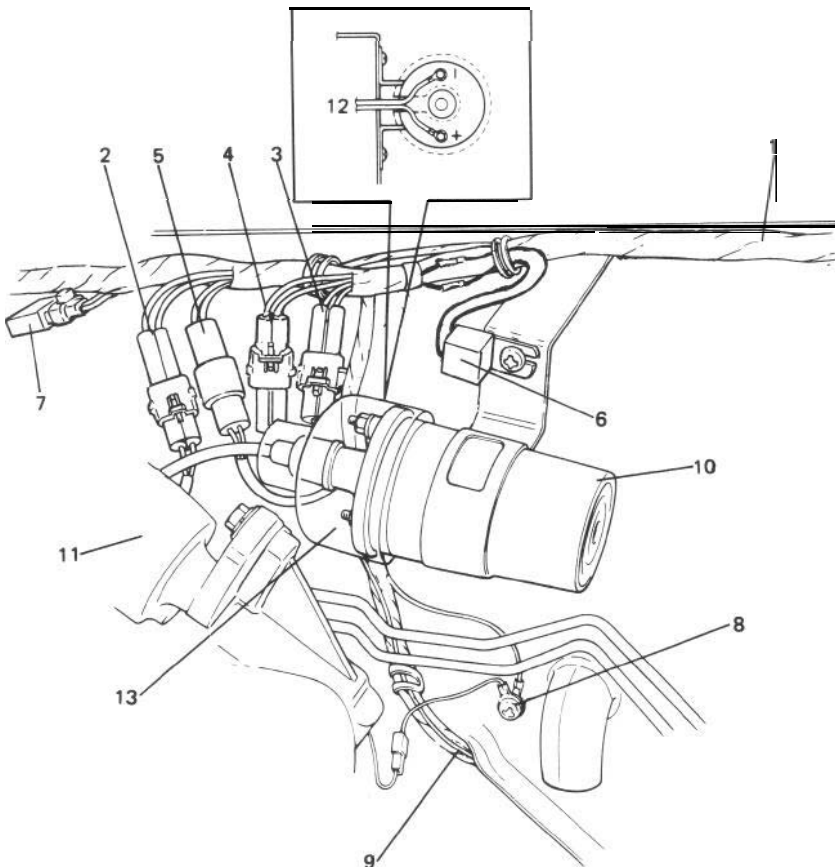
**Fig. 27-37**



- 1) Battery
- 2) Fusible link
- 3) To starter
- 4) To starter, alternator, etc
5. Earth
- 6) Earth (To starter mounting bolt)
- 7) Wiring harness No.2

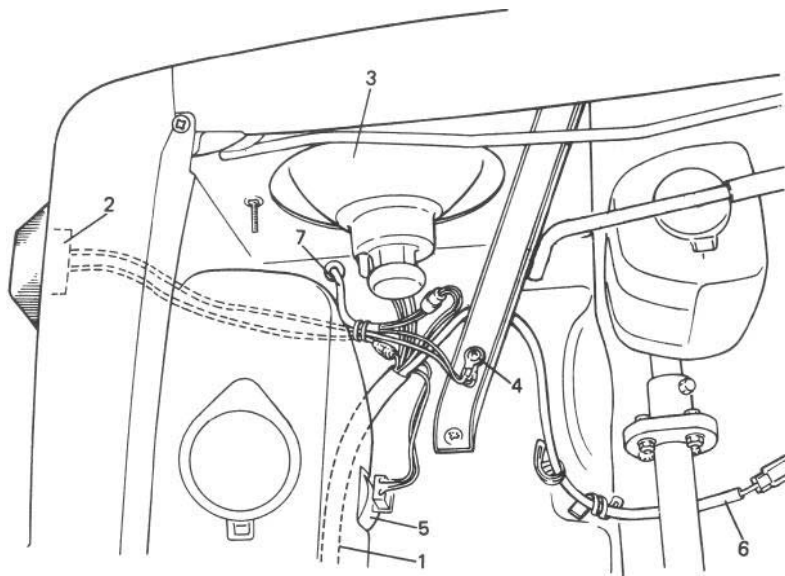


1. From wire harness No.2
- 2) TWSV (Three way solenoid valve)
- 3) Water temperature gauge
- 4) Alternator
- 5) Intake manifold
- 6) Clamp
- 7) To VSV
- 8) Thermal switch
- 9) Mount this terminal horizontally as shown
- 10) Thermostat cap



- 1) Wire harness No.2
- 2) To distributor
- 3) To fifth switch
- 4) To back up light switch
- 5) To ignition coil
- 6) Condenser
7. Noise suppressor filter (Clamp it toward engine room so as to prevent it from contacting dash panel edge.)
- 8) Earth
- 9) To license light, stop/tail light, 4WD switch
- 10) Ignition coil
- 11) Distributor
- 12) To wire harness No.2
- 13) Ignition coil cap

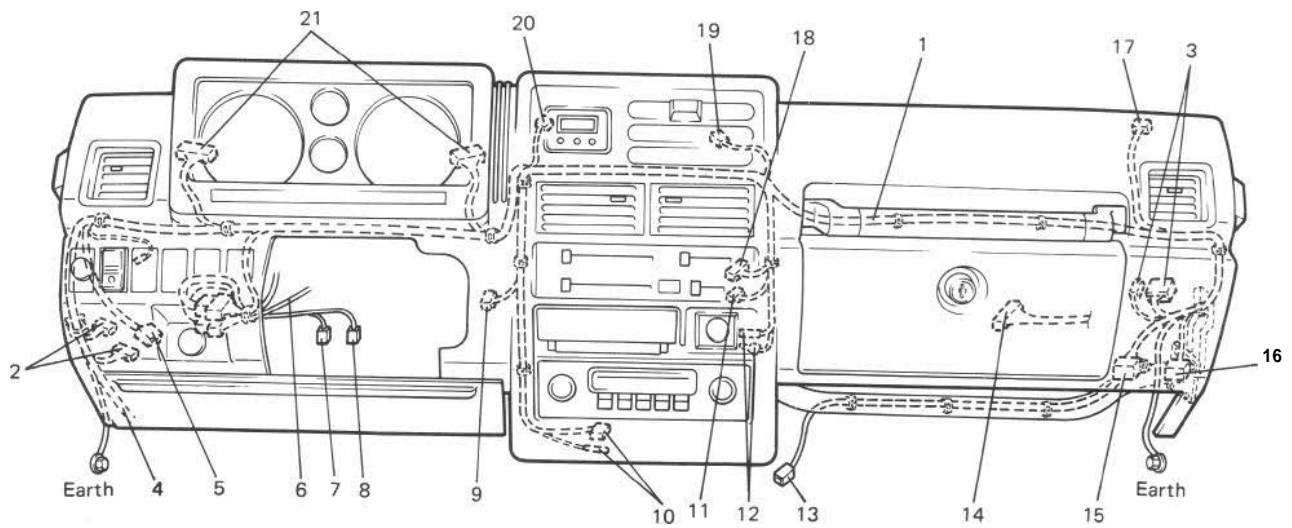
Fig. 21-38



1. Wire harness No. 2
2. Side marker light
3. Head light
4. Earth
5. Washer motor
6. To oil pressure gauge
7. To combination light

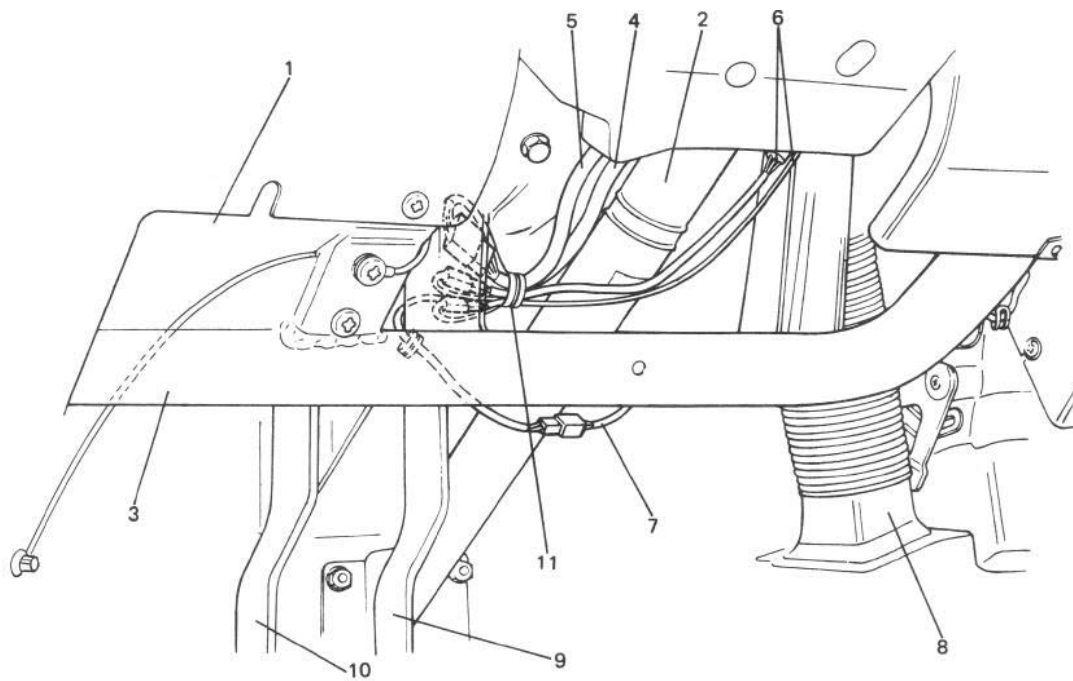
Fig. 21-39

**Instrument Panel Wiring**



- |                          |                           |                          |
|--------------------------|---------------------------|--------------------------|
| 1. Wire harness No. 1    | 8. To stop lamp switch    | 15. Door warning buzzer  |
| 2. To wire harness No. 2 | 9. To heater blower motor | 16. Check relay          |
| 3. To wire harness No. 2 | 10. To radio              | 17. To wiper motor       |
| 4. To fuse box           | 11. To heater fan switch  | 18. To illumination lamp |
| 5. Horn relay            | 12. To cigar light        | 19. To optional meter    |
| 6. To combination switch | 13. To radio              | 20. To clock             |
| 7. To clutch switch      | 14. To ECM                | 21. To meter             |

Fig. 21-40



- |   |   |
|---|---|
| <ul style="list-style-type: none"> <li>1. Instrument panel</li> <li>2. Steering column</li> <li>3. Steering column holder</li> <li>4. Wiring harness No. 1</li> <li>5. To combination switch</li> <li>6. To ignition switch</li> <li>7. To clutch switch</li> </ul> | <ul style="list-style-type: none"> <li>8. Defroster hose</li> <li>9. Brake pedal</li> <li>10. Clutch pedal</li> <li>11. Clamp lead wires of ignition switch and combination switch, using care not to allow lead wires to contact the edge of steering column bracket.</li> </ul> |
|---|---|

Fig. 21-41

## 21-16. WIRING DIAGRAM

Wiring diagrams are attached at the end of this manual.

# SECTION 22

## SERVICE DATA

### CONTENTS

**22-1. SPECIFICATIONS..... 22-1**

**22-2. SERVICE DATA ..... 22-4**

### 22-1. SPECIFICATIONS

Item	Models	Convertible/Hardtop
<b>ENGINE</b>		
Type	Four-stroke cycle, water cooled, OHC	
Number of cylinders	4	
Lubrication system	Wet sump	
Bore	74.0 mm (2.91 in.)	
Stroke	77.0 mm (3.03 in.)	
Piston displacement	1,324 cm <sup>3</sup> (1,324 cc, 80.8 cu. in.)	
Compression ratio	8.9 : 1	
Carburetor	HITACHI two-barrel down draft	
Air cleaner	Polyester fiber element (Dry type)	
<b>ELECTRICAL</b>		
Ignition timing	10° B.T.D.C. at 800 r/min (rpm)	
Standard spark plug	NGK BPR-5ES or NIPPON DENSO W16EXR-U	
Starter	Magnetic shift type	
Generator	Alternator	
Battery	12V, 137 kC (38 Ah)/5HR * 12V, 130 kC (36 Ah)/5HR	
Headlight	12V, 60/50W	
Turn signal light	12V, 32 cp	
Clearance light	12V, 4 cp	

\* : For Canadian specification vehicle

ITEM	Models	Convertible/Hardtop
Tail/Brake light		12V, 3/32 cp
Side marker light		12V, 3.8W
License plate light		12V, 4 cp
Back-up light		12V 32 cp
Interior light		12V, 5w
Meter pilot light		12V, 1.4W
Main fuse		0.5 mm <sup>2</sup> (fusible link)
Fuse box		10/10/1 0/10/10/15/15/15/15/15/10/5/5/5A
<b>POWER TRANSMISSION</b>		
Clutch type		Dry, single disc
Transmission type		5-forward all synchromesh, 1 reverse
Final reduction ratio		3.727
Gear ratios	low	3.652
	2nd	1.947
	3rd	1.423
	4th	1.000
	5th	0.864
	reverse	3.466
Transfer gear ratios	low range	2.268
	high range	1.409
Overall reduction ratios:		
Low range	low	30.869
	2nd	16.457
	3rd	12.028
	4th	8.452
	5th	7.303
	reverse	29.297
High range	low	19.177
	2nd	10.224
	3rd	7.472
	4th	5.251
	5th	4.537
	reverse	18.201

Item	Models	Convertible/Hard Top
<b>WHEEL AND SUSPENSION</b>		
Tire size: front and rear		P205/70 R 15
Tire pressure	front	140 kPa (1.40 kg/cm <sup>2</sup>   20 psi)
	rear	140 kPa (1.40 kg/cm <sup>2</sup>   20 psi)-unladen
		180 kPa (1.80 kg/cm <sup>2</sup>   26 psi)-laden
Suspension type	front	Leaf spring
	rear	Leaf spring
<b>STEERING</b>		
Turning radius		5.1m (16.7 ft)
Steering gear box		Ball nut type
Toe-in		2 – 6 mm (0.08 – 0.24 in.)
Camber angle		1° 00'
Caster angle		3° 30'
King pin angle		9° 00'
<b>BRAKE SYSTEM</b>		
Type		4-wheel   hydraulic
Wheel brake	front	Disc brake (floating caliper type)
	rear	Drum brake (leading and trailing)
Parking brake		Mechanical actuated on rear wheels
<b>CAPACITIES</b>		
Cooling solution		4.8 ℓ (10.1/8.4 US/Imp pt)
Fuel tank		40ℓ (10.6/8.8 US/Imp gal)
Engine oil		3.5 ℓ (7.4/6.2 US/Imp pt)
Transmission oil		1.3 ℓ (2.7/2.3 US/Imp pt)
Differential gear box oil	front	2.0 ℓ (4.2/3.5 US/Imp pt)
	rear	1.5 ℓ (3.2/2.6 US/Imp pt)
Transfer gear box oil		0.8 ℓ (1.7/1.4 US/Imp pt)

## 22-2. SERVICE DATA

### ENGINE

Item		Standard		Service Limit		
COMPRESSION PRESSURE			14.0 kg/cm <sup>2</sup> (199.0 psi)/400 r/min (rpm)		12.0 kg/cm <sup>2</sup> (170.0 psi)/400 r/min (rpm)	
	Difference between cylinders		_____		1.0 kg/cm <sup>2</sup> (14.2 psi)/400 r/min (rpm)	
Valve lash (clearance)	Cold (When coolant temperature is 15 ~ 25°C or 59 ~ 77°F)	Inlet	0.13 ~ 0.17 mm (0.0051 ~ 0.0067 in.)		_____	
		Exhaust	0.16 ~ 0.20 mm (0.0063 ~ 0.0079 in.)		_____	
	Hot (When coolant temperature is 60 ~ 68°C or 140 ~ 154°F)	Inlet	0.23 ~ 0.27 mm (0.009 ~ 0.011 in.)		_____	
		Exhaust	0.26 ~ 0.30 mm (0.0102 ~ 0.0118 in.)		_____	
Cylinder head	Flatness of gasketed surface		_____		0.05 mm (0.002 in.)	
	Flatness of manifold seat	Inlet	_____		0.1 mm (0.004 in.)	
		Exhaust	_____		0.1 mm (0.004 in.)	
	Valve seat	Seating width	Inlet	1.3 ~ 1.5 mm (0.0512 ~ 0.0590 in.)		_____
			Exhaust	1.3 ~ 1.5 mm (0.0512 ~ 0.0590 in.)		_____
	Seating angle		45°		_____	
Valve guide hole diameter (In & Ex) (over size)		12.030 ~ 12.048 mm (0.4736 ~ 0.4743 in.)		_____		
Valve, valve spring & cam shaft	Camshaft/Journal clearance		0.050 ~ 0.091 mm (0.0020 ~ 0.0036 in.)		0.15 mm (0.0059 in.)	
	Camshaft thrust clearance		_____		0.75 mm (0.0295 in.)	
	Cam height (Base circle + lift)	Inlet	37.500 mm (1.4763 in.)		37.400 mm (1.4724 in.)	
		Exhaust	37.500 mm (1.4763 in.)		37.400 mm (1.4724 in.)	
		Fuel pump cam	40.000 mm (1.5748 in.)		39.600 mm (1.5590 in.)	
	Camshaft runout		_____		0.10 mm (0.0039 in.)	
	Valve stem diameter	Inlet	6.965 ~ 6.980 mm (0.2742 ~ 0.2748 in.)		_____	
		Exhaust	6.950 ~ 6.965 mm (0.2737 ~ 0.2742 in.)		_____	
	Valve guide I.D.	Inlet	7.000 ~ 7.015 mm (0.2756 ~ 0.2761 in.)		_____	
		Exhaust	7.000 ~ 7.015 mm (0.2756 ~ 0.2761 in.)		_____	
	Valve guide-to-valve stem clearance	Inlet	0.020 ~ 0.050 mm (0.0008 ~ 0.0019 in.)		0.07 mm (0.0027 in.)	
		Exhaust	0.035 ~ 0.065 mm (0.0014 ~ 0.0025 in.)		0.09 mm (0.0035 in.)	
	Thickness of valve head periphery	Inlet	1.0 mm (0.039 in.)		0.6 mm (0.0236 in.)	
		Exhaust	1.0 mm (0.039 in.)		0.7 mm (0.0275 in.)	
Contact width of valve and valve seat	Inlet	1.3 ~ 1.5 mm (0.0512 ~ 0.0590 in.)		_____		
	Exhaust	1.3 ~ 1.5 mm (0.0512 ~ 0.0590 in.)		_____		
Valve spring free length	Inlet	49.3 mm (1.9409 in.)		48.1 mm (1.8937 in.)		
	Exhaust	49.3 mm (1.9409 in.)		48.1 mm (1.8937 in.)		
Valve spring preload	Inlet	24.8 ~ 29.2 kg (54.7 ~ 64.3 lb) for fitting length 41.5 mm (1.63 in.)		22.8 kg (50.2 lb) for fitting length 41.5 mm (1.63 in.)		
	Exhaust	24.8 ~ 29.2 kg (54.7 ~ 64.3 lb) for fitting length 41.5 mm (1.63 in.)		22.8 kg (50.2 lb) for fitting length 41.5 mm (1.63 in.)		



Item			Standard	Service Limit
Valve, valve spring & cam shaft	Valve stem end deflection	Inlet	_____	0.14 mm (0.005 in.)
		Exhaust	_____	0.18 mm (0.007 in.)
	Stock allowance of valve stem end face		_____	0.5 mm (0.019 in.)
	Valve head radial runout		_____	0.08 mm (0.003 in.)
	Valve spring squareness		_____	2.0 mm (0.079 in.)
	Valve guide protrusion (In. & Ex.)		14 mm (0.55 in.)	_____
Rocker arm shaft and rocker arm	Rocker shaft O.D.		15.973 ~ 15.988 mm (0.628 ~ 0.629 in.)	_____
	Rocker arm I.D.		16.000 ~ 16.018 mm (0.629 ~ 0.630 in.)	_____
	Shaft-to-arm clearance	Inlet	0.012 ~ 0.045 mm (0.0005 ~ 0.0017 in.)	0.09 mm (0.0035 in.)
		Exhaust	0.012 ~ 0.045 mm (0.0005 ~ 0.0017 in.)	0.09 mm (0.0035 in.)
Rocker shaft runout		_____	0.12 mm (0.004 in.)	
Cylinder	Flatness of gasketed surface		0.03 mm (0.0012 in.)	0.06 mm (0.0024 in.)
	Cylinder bore (S.T.D.)		74.00 ~ 74.02 mm (2.9134 ~ 2.9142 in.)	74.15 mm (2.9193 in.)
	Cylinder bore out-of-round and taper		_____	0.10 mm (0.0039 in.)
	Cylinder-to-piston clearance		0.02 ~ 0.04 mm (0.0008 ~ 0.0015 in.)	_____
Piston	Piston diameter	Standard	73.970 ~ 73.990 mm (2.9122 ~ 2.9129 in.)	_____
		Oversize: 0.25 mm (0.0098 in.)	74.220 ~ 74.230 mm (2.9220 ~ 2.9224 in.)	_____
		Over size: 0.50 mm (0.0196 in.)	74.470 ~ 74.480 mm (2.9319 ~ 2.9322 in.)	_____
	Piston ring groove width	Top ring	1.22 ~ 1.24 mm (0.0480 ~ 0.0488 in.)	_____
		2nd ring	1.51 ~ 1.53 mm (0.0594 ~ 0.0602 in.)	_____
		Oil ring	2.81 ~ 2.83 mm (0.1106 ~ 0.1114 in.)	_____
Piston pin diameter		16.995 ~ 17.000 mm (0.6691 ~ 0.6693 in.)	_____	
Piston ring	Piston ring thickness	Top ring	1.17 ~ 1.19 mm (0.0461 ~ 0.0468 in.)	_____
		2nd ring	1.47 ~ 1.49 mm (0.0578 ~ 0.0586 in.)	_____
		Oil ring	0.45 mm (0.0177 in.)	_____
	Ring clearance in groove	Top ring	0.03 ~ 0.07 mm (0.0012 ~ 0.0027 in.)	0.12 mm (0.0047 in.)
		2nd ring	0.02 ~ 0.06 mm (0.0008 ~ 0.0023 in.)	0.10 mm (0.0039 in.)
	Piston ring end gap	Top ring	0.20 ~ 0.33 mm (0.0079 ~ 0.0129 in.)	0.7 mm (0.0275 in.)
2nd ring		0.20 ~ 0.35 mm (0.0079 ~ 0.0137 in.)	0.7 mm (0.0275 in.)	
Oil ring		0.20 ~ 0.70 mm (0.0079 ~ 0.0275 in.)	1.8 mm (0.0708 in.)	
Crank shaft	Crankshaft runout (middle)		_____	0.06 mm (0.0023 in.)
	Crank pin diameter		41.982 ~ 42.000 mm (1.6529 ~ 1.6535 in.)	_____
	Crank pin clearance in con. rod		0.030 ~ 0.050 mm (0.0012 ~ 0.0019 in.)	0.08 mm (0.0031 in.)
	Connecting rod small end bore		16.968 ~ 16.979 mm (0.6680 ~ 0.6684 in.)	_____
	Crank journal diameter		44.982 ~ 45.000 mm (1.7710 ~ 1.7716 in.)	_____
	Bearing-to-journal clearance		0.020 ~ 0.040 mm (0.0008 ~ 0.0016 in.)	0.06 mm (0.0023 in.)
	Crank pin out-of-round and taper		_____	0.01 mm (0.0004 in.)

Item		Standard		Service Limit		
Crankshaft	Crank journal out-of-round and taper		_____		0.01 mm	(0.0004 in.)
	Flywheel runout		_____		0.2 mm	(0.0078 in.)
	Crankshaft thrust play		0.11 – 0.31 mm	(0.0044 ~ 0.0122 in.)	0.38 mm	(0.0149 in.)
	Connecting rod big end side clearance		0.10 ~ 0.20 mm	(0.0039 ~ 0.0078 in.)	0.35 mm	(0.0137 in.)
	Connecting rod	Twist	_____		0.10 mm	(0.0039 in.)
Bow		_____		0.05 mm	(0.0020 in.)	

## CLUTCH & TRANSMISSION

Item		Standard		Service Limit		
Clutch	Pedal free travel		20 ~ 30 mm	(0.8 ~ 1.1 in.)	_____	
	Facing wear (Rivet head depth)		1.2 mm	(0.05 in.)	0.5 mm	(0.02 in.)
	Facing-input shaft serration backlash		_____		0.8 mm	(0.03 in.)
	Clutch release arm play		2 ~ 4 mm	(0.08 ~ 0.16 in.)	_____	
Transmission	Clearance between gears and rings	Low & high	1.0 ~ 1.4 mm	(0.039 ~ 0.055 in.)	0.5 mm	(0.019 in.)
		5th speed	1.2 ~ 1.6 mm	(0.047 ~ 0.063 in.)	0.5 mm	(0.019 in.)
	Key slot width of synchronizer ring		10.1 mm	(0.397 in.)	10.4 mm	(0.409 in.)
	Gear shift fork shaft spring free length		25.5 mm	(1.004 in.)	21.0 mm	(0.826 in.)
	Gear backlash		0.06 ~ 0.15 mm	(0.0024 ~ 0.0059 in.)	0.3 mm	(0.0118 in.)

## LUBRICATION

Item		Standard		Service Limit		
Lubrication	Radial clearance between outer rotor and case		_____		0.310 mm	(0.0122 in.)
	Oil pump side clearance (flatness)		_____		0.15 mm	(0.0059 in.)
	Oil relief valve spring	Free length	45 mm	(1.77 in.)	_____	
	Set pressure of oil pressure switch		0.2 ~ 0.4 kg/cm <sup>2</sup>	(2.84 ~ 5.68 psi)	_____	
	Engine oil pressure		3.0 ~ 4.2 kg/cm <sup>2</sup> (42.7 ~ 59.7 psi) at 3,000 r/min (rpm)		_____	

## COOLING SYSTEM

Item		Standard		Service Limit
Cooling system	Fan belt tension as deflection under 10 kg (22 lb) push applied to middle point between pulleys	6 ~ 9 mm	(0.23 ~ 0.35 in.)	_____
	Thermostat start-to-open temperature	*82°C (179°F) or 88°C (190°F)		_____
	Thermostat full-open temperature	*95°C (203°F) or 100°C (212°F)		_____
	Valve lift	8 mm	(0.31 in.)	_____

\* There are two types of thermostat depending on specifications.

## DIFFERENTIAL

Item		Standard		Service Limit
Differ- ential	Bevel gear backlash	0.10 ~ 0.15 mm	(0.004 ~ 0.006 in.)	_____
	Side gear thrust play	0.12 ~ 0.37 mm	(0.005 ~ 0.014 in.)	_____
	Pinion bearing preload	1.8 ~ 3.4 kg	(4.0 ~ 7.5 lbs.)	_____

## SUSPENSION

Item		Standard		Service Limit
Suspension	Front wheel bearing starting preload	1.0 ~ 3.0 kg	(2.2 ~ 6.6 lbs.)	_____
	Rear wheel bearing thrust play	_____		0.8 mm (0.03 in.)
	Axial play in barfield joint	0 mm (No play)		1.5 mm (0.06 in.)
	Knackle arm starting torque (without oil seal)	1.0 ~ 1.8 kg (2.20 ~ 3.96 lbs.)		_____

## CARBURETOR

Item		Standard		Limit
Engine idle speed		800 ± 50 r/min (rpm)		_____
Engine idle speed when turning head light "ON"		950 ± 50 r/min (rpm)		_____
Float level	Float height	8 mm	(0.31 in.)	_____
Accelerator cable play	When engine is cold	10 – 15 mm	(0.4 ~ 0.6 in.)	_____
	When engine is hot	3 ~ 5 mm	(0.12 ~ 0.20 in.)	_____

## STEERING SYSTEM

Item	Standard	Service Limit
Gear ratio	15.6 ~ 18.1	_____
Steering angle, inside	29°	_____
Steering angle, outside	26°	_____
Steering wheel play	10 ~ 30 mm (0.4 ~ 1.2 in.)	_____

## BRAKE

Item	Standard	Service Limit
Front brake disc thickness	10 mm (0.394 in.)	8.5 mm (0.334 in.)
Front brake disc deflection	_____	0.15 mm (0.006 in.)
Front brake pad thickness (lining + pad rim)	15.0 mm (0.590 in.)	6.0 mm (0.236 in.)
Rear brake lining thickness (lining + shoe rim)	7.0 mm (0.28 in.)	3.0 mm (0.12 in.)
Rear brake drum inside diameter	220 mm (8.66 in.)	222 mm (8.74 in.)
Pedal-to-wall clearance: When pedal is depressed at 30 kg (66 lb)	75 mm (2.95 in.) minimum	_____

## ELECTRICAL

	Item	Standard	Service Limit
Ignition system	Ignition order	1 - 3 - 4 - 2	_____
	Signal rotor air gap	0.2 ~ 0.4 mm (0.008 ~ 0.016 in.)	_____
	Generator resistance	130 ~ 190 ohms	_____
	High tension cord resistance	16 k $\Omega$ /3.3 ft (1 m)	20 k $\Omega$ /pc
	Ignition coil; Primary coil resistance (20°C)	1.35 ~ 1.65 ohms	_____
	Ignition coil; Secondary coil resistance (20°C)	11.0 ~ 14.5 kilohms	_____
	Spark plug gap	0.7 ~ 0.8 mm (0.027 ~ 0.031 in.)	_____



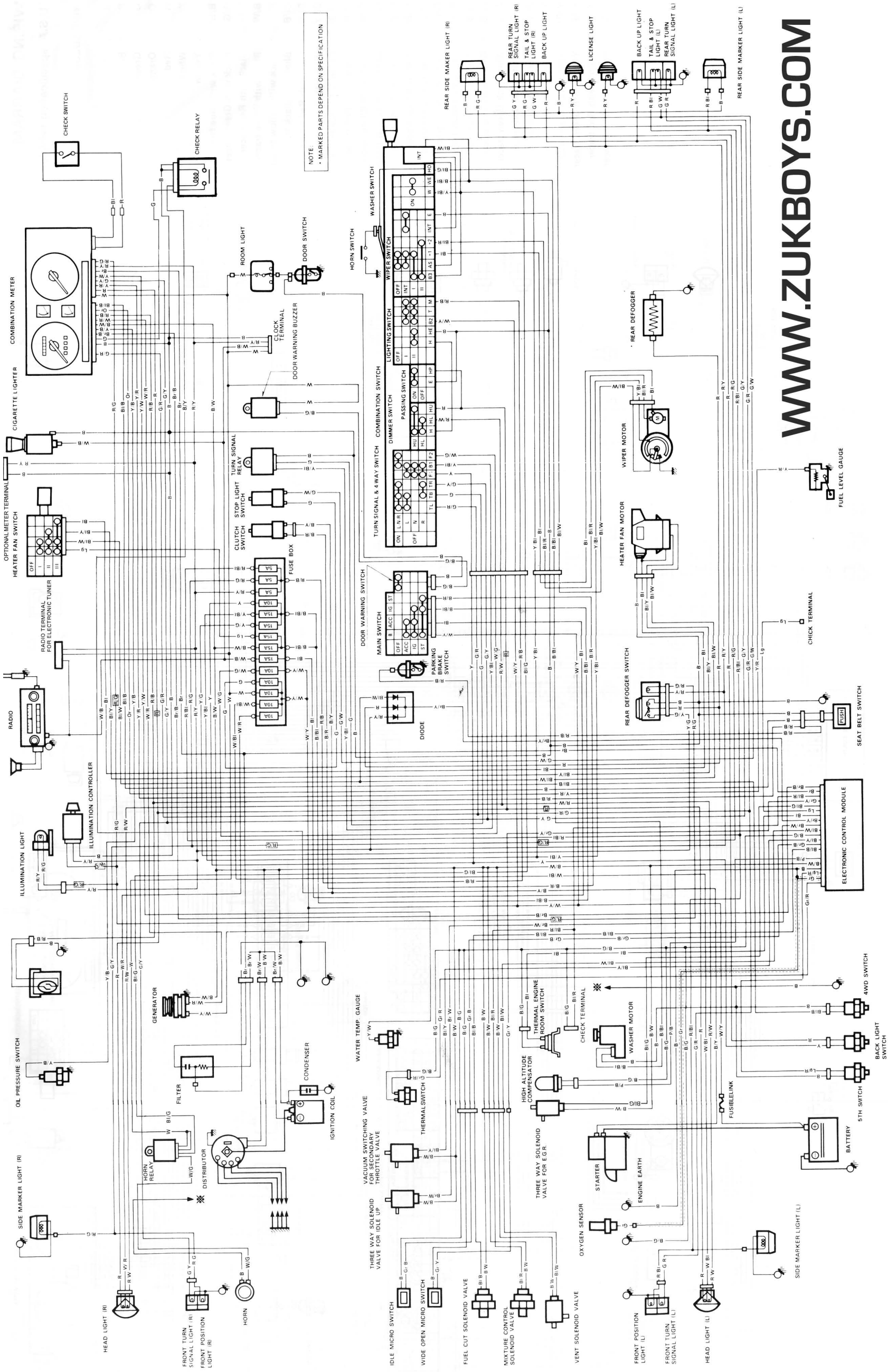
	Item	Standard	Service Limit
Starter motor	Voltage	12 Volts	_____
	Output	0.9 kw	_____
	Rating	30 seconds	_____
	Brush length	17 mm (0.67 in.)	11.5 mm (0.45 in.)
	Number of pinion teeth	8	_____
	Commutator diameter	32 mm (1.26 in.)	31 mm (1.22 in.)
	Mica depth	0.4 ~ 0.6 mm (0.015 ~ 0.023 in.)	0.2 mm (0.008 in.)
	Commutator out of round	0.05 mm (0.0019 in.) or less	0.4 mm (0.015 in.)
	Brush spring tension	1.6 kg (3.53 lb)	1.0 kg (2.20 lb)
Charging system	Nominal operating voltage	12 Volts	_____
	Maximum alternator output	45A	_____
	Maximum permissible alternator speed	15,000 r/min (rpm)	_____
	Working temperature range	-30 ~ 90°C (-22 ~ 194°F)	_____
	Rotor; Ring-to-ring circuit resistance	2.8 ~ 3.0 ohms	_____
	Brush length	11.0 mm (0.43 in.)	5.0 mm (0.20 in.)
	Standard output voltage and current	14.2 ~ 14.8 Volts, 10A maximum	_____
	Regulated voltage	14.2 ~ 14.8 Volts	_____

# WIRING DIAGRAM

[ CANADIAN, specification vehicle ]

## WIRE COLOR

- B : Black
- Bl : Blue
- G : Green
- Or : Orange
- R : Red
- W : White
- Y : Yellow
- B/Bl : Black with Blue tracer
- B/G : Black with Green tracer
- B/R : Black with Red tracer
- B/W : Black with White tracer
- B/Y : Black with Yellow tracer
- Bl/B : Blue with Black tracer
- Bl/R : Blue with Red tracer
- Bl/Y : Blue with Yellow tracer
- G/Bl : Green with Blue tracer
- G/R : Green with Red tracer
- G/W : Green with White tracer
- G/Y : Green with Yellow tracer
- R/B : Red with Black tracer
- R/Bl : Red with Blue tracer
- R/G : Red with Green tracer
- R/W : Red with White tracer
- R/Y : Red with Yellow tracer
- W/B : White with Black tracer
- W/Bl : White with Blue tracer
- W/G : White with Green tracer
- W/R : White with Red tracer
- W/Y : White with Yellow tracer
- Y/B : Yellow with Black tracer
- Y/Bl : Yellow with Blue tracer
- Y/G : Yellow with Green tracer
- Y/R : Yellow with Red tracer
- Y/W : Yellow with White tracer



WWW.ZUKBOYS.COM



# *1986 & 1987 Suzuki Samurai Factory Service Manual*

Prepared by

**SUZUKI** MOTOR **CO.,LTD.**

Technical Department  
Automobile Service Division

1st Ed. November, 1987

Printed in Japan



# TABLE OF CONTENTS

	SECTION
<b>GENERAL, SPECIAL TOOLS AND SERVICE MATERIALS</b>	<b>0</b>
<b>PERIODIC MAINTENANCE SERVICE</b>	<b>1</b>
<b>TROUBLE SHOOTING</b>	<b>2</b>
<b>ENGINE</b>	<b>3</b>
<b>FUEL SYSTEM (CARBURETOR, AIR CLEANER, FUEL PUMP AND FUEL FILTER)</b>	<b>4</b>
<b>EMISSION CONTROL SYSTEM</b>	<b>5</b>
<b>ENGINE COOLING SYSTEM</b>	<b>6</b>
<b>CAR HEATER</b>	<b>7</b>
<b>IGNITION SYSTEM</b>	<b>8</b>
<b>CRANKING SYSTEM</b>	<b>9</b>
<b>CHARGING SYSTEM</b>	<b>10</b>
<b>CLUTCH</b>	<b>11</b>
<b>GEAR SHIFTING CONTROL</b>	<b>12</b>
<b>TRANSMISSION</b>	<b>13</b>
<b>TRANSFER GEAR BOX</b>	<b>14</b>
<b>PROPELLER SHAFTS</b>	<b>15</b>
<b>DIFFERENTIAL</b>	<b>16</b>
<b>SUSPENSION</b>	<b>17</b>
<b>STEERING SYSTEM</b>	<b>18</b>
<b>BRAKES</b>	<b>19</b>
<b>BODY SERVICE</b>	<b>20</b>
<b>BODY ELECTRICAL EQUIPMENT</b>	<b>21</b>
<b>SERVICE DATA</b>	<b>22</b>
	<b>23</b>



## SECTION 0

# GENERAL, SPECIAL TOOLS AND SERVICE MATERIALS

0

## CONTENTS

0-1. IDENTIFICATION NUMBER .....	0-1
0-2. STANDARD SHOP PRACTICES .....	0-2
0-3. SPECIAL TOOLS .....	0-5
0-4. REQUIRED SERVICE MATERIALS .....	0-9
0-5. METRIC INFORMATION .....	0-12

### 0-1. IDENTIFICATION NUMBER

#### VEHICLE IDENTIFICATION NUMBER

The vehicle identification number is on the left front pillar.

Refer to below figure for detailed VIN cord information and its location.

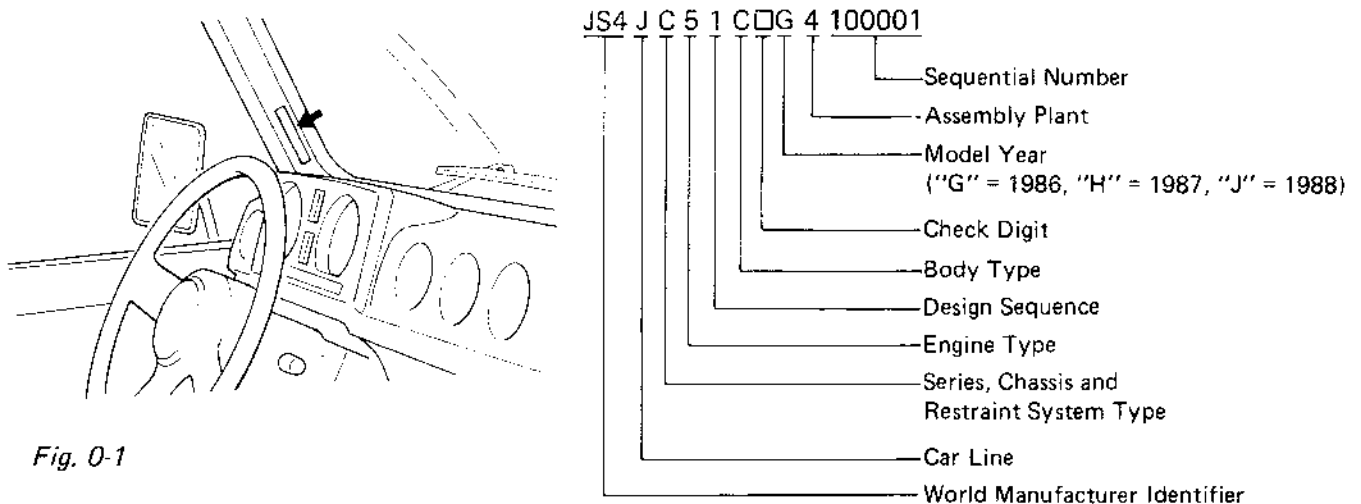


Fig. 0-1

#### ENGINE IDENTIFICATION NUMBER

The engine number is punched on the rear portion of the left-hand skirt part of cylinder block.

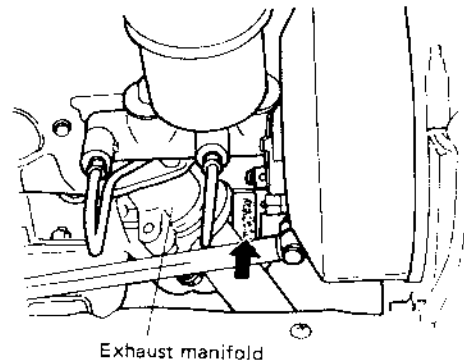


Fig. 0-2 Location of Engine No.

## 0-2. STANDARD SHOP PRACTICES

1. Protect painted surfaces of the body, and avoid staining or tearing seats. When working on fenders and seats, be sure to cover them up with sheets.
2. Disconnect negative terminal connection of the battery when working on any electrical part or component. This is necessary for avoiding electrical shocks and short-circuiting, and is very simple to accomplish: merely loosen wing nut on negative terminal and separate cable from terminal post.
3. In raising front or rear car end off the floor by jacking, be sure to put the jack against differential portion of axle housing.

### NOTICE:

Don't get on the car, get under it or service it in this state.

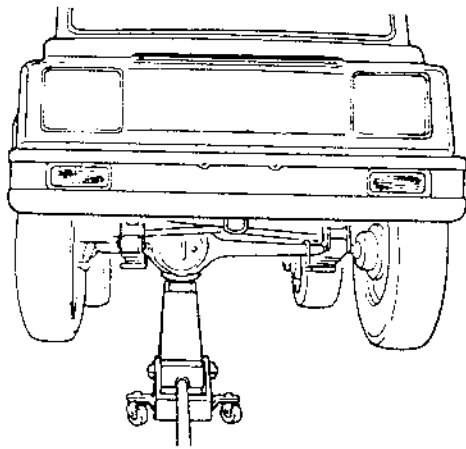


Fig. 0-3 Front Side

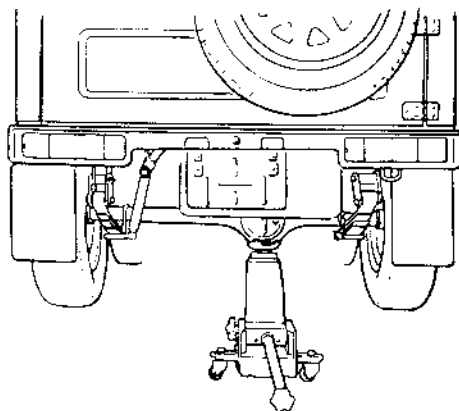


Fig. 0-4 Rear Side

4. To perform service with either front or rear car end jacked up, be sure to place safety stands under chassis frame so that body is securely supported. Refer to below figures for where to place safety stands. And then check to ensure that chassis frame does not slide on safety stands and the car is held stable for safety's sake.

### IMPORTANT:

Place chocks against both right and left wheels on the ground from both front and rear.

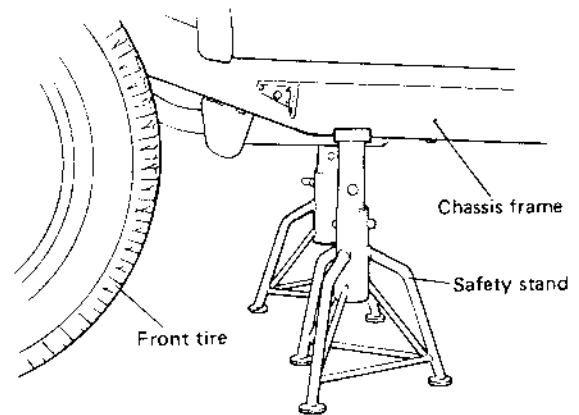


Fig. 0-5 Front Side

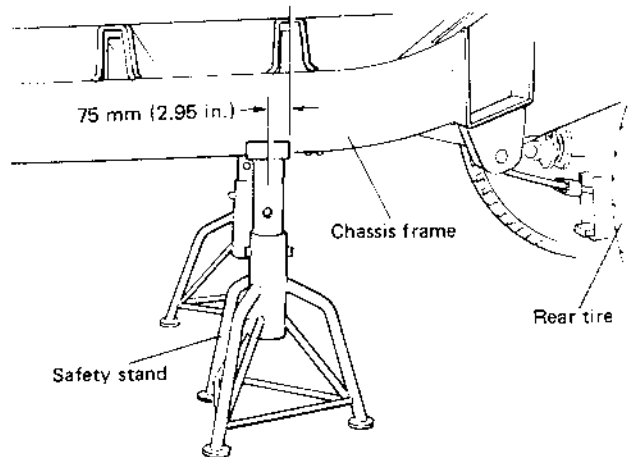


Fig. 0-6 Rear Side

5. Fig. 0-7 and 0-8 show how to lift the car by using a hoist.

**IMPORTANT:**

- When using frame contact hoist, apply hoist as shown below (right and left at the same position). Lift up the car till 4 tires are a little off the ground and make sure that the car will not fall off by trying to move car body in both ways. Work can be started only after this confirmation.
- Before applying hoist to underbody, always take car balance throughout service into consideration. Car balance on hoist may change depending of what part to be removed.
- For suspension parts removal, follow previous steps 3 and 4.
- Make absolutely sure to lock hoist after car is hoisted up.

When using frame contact hoist:

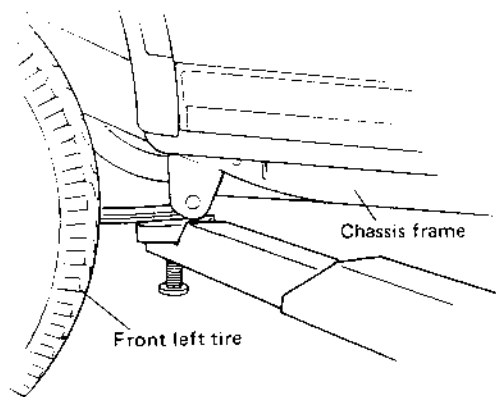


Fig. 0-7 Front Support Location

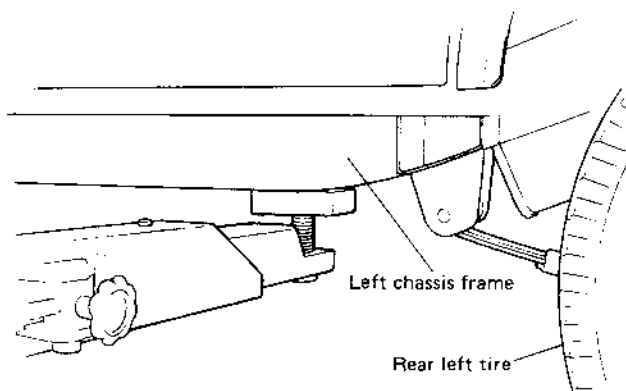


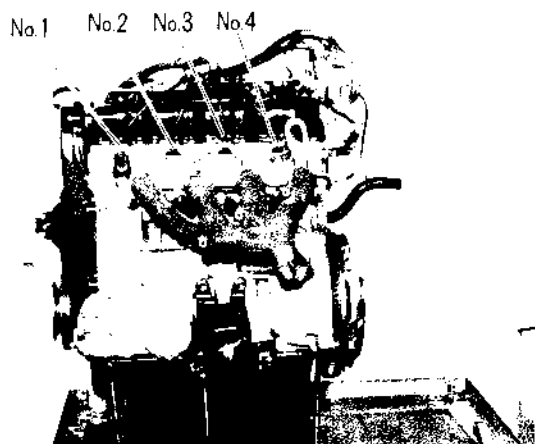
Fig. 0-8 Rear Support Location

6. Orderliness is a key to successful overhauling. Trays, pans and shelves are needed to set aside disassembled parts in groups or sets in order to avoid confusion and misplacement. This is particularly important for engine overhauling.
7. Have on hand liquid packing—SUZUKI BOND No. 1215 (99000-31110) — for ready use. This packing dope is an essential item to assure leak-free (water and oil) workmanship.
8. Each bolt must be put back to where it was taken from or for which it is intended. Do not depend on your hunch in tightening bolts for which tightening torque values are specified: be sure to use torque wrenches on those bolts.
9. It is advisable to discard and scrap gaskets and "O" rings removed in disassembly. Use new ones in reassembly, and try not to economize gaskets and "O" rings.
10. Use of genuine SUZUKI parts is imperative. Use of imitation parts is a big gamble on safety and performance. Use genuine SUZUKI parts and live up to the trust your customer places on you.
11. Special tools save time and ensure good workmanship: They are available from SUZUKI. Use them where their use is specified. Moreover, your own safety is assured by the use of special tools in many of the disassembly and reassembly steps.

12. Refer to the contents of this MANUAL as often as practical, and do each job properly as prescribed.

**NOTICE:**

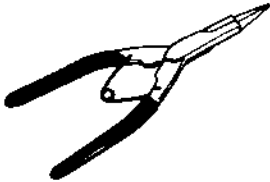
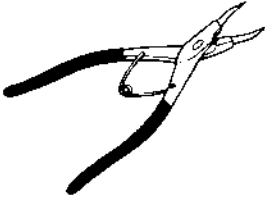
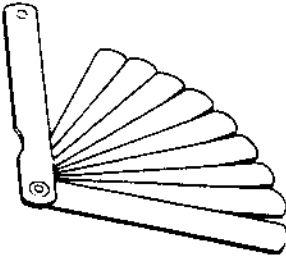
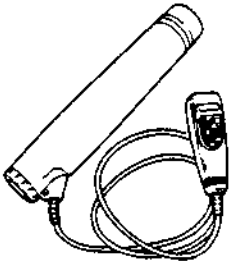
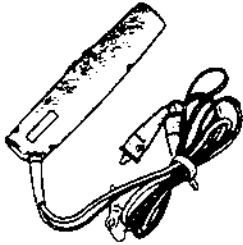
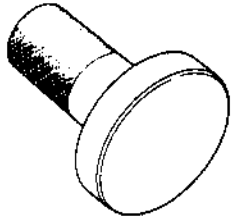
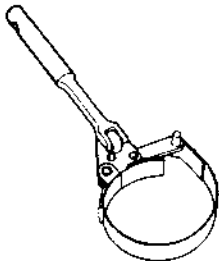
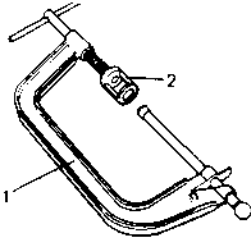
Engine cylinders are identified by numbers. See Fig. 0-9. Counting from the front end, the cylinders are referred to as No. 1, No. 2, No. 3 and No. 4 cylinders.

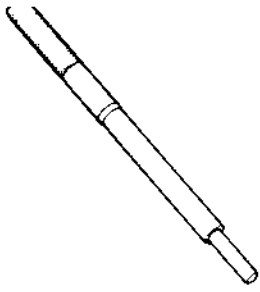


*Fig. 0-9 Engine Cylinder Numbers*

### 0-3. SPECIAL TOOLS

Special tools assure three things: 1) improved workmanship; 2) speedy execution of jobs for which they are meant; and 3) protection of parts and components against damage. Here are the special tools prescribed for this Model:

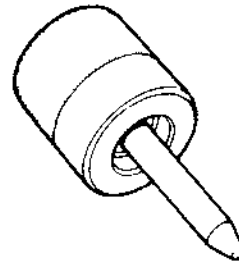
 <p>09900-06107 Snap ring plier (opening type)</p>	 <p>09900-06108 Snap ring plier (closing type)</p>	 <p>09900-20803 Thickness gauge</p>	 <p>09900-25002 Pocket tester</p>
 <p>09900-27311 Timing light (Dry cell type)</p>	 <p>09900-27301 Timing light (D.C. 12V)</p>	 <p>1. 09927-18410 Universal puller 2. 09921-57810 Bearing remover</p>	 <p>09913-75510 Bearing installer</p>
 <p>09913-60910 Bearing puller</p>	 <p>09915-47310 Oil filter wrench</p>	 <p>1. 09916-14510 Valve lifter 2. 09916-48210 Valve lifter attachment</p>	 <p>09926-48010 Universal joint assembler</p>



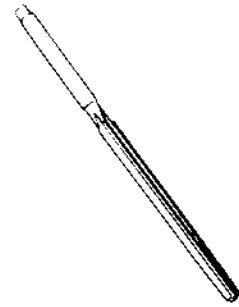
09916-44511  
Valve guide remover



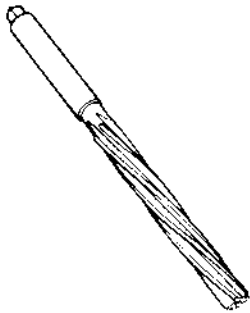
09917-88210  
Valve guide installer



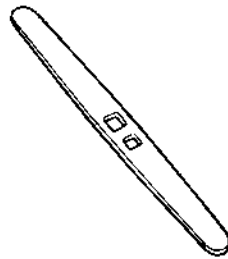
09917-98210  
Valve stem seal installer



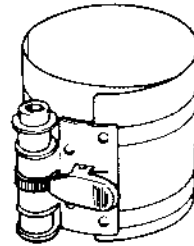
09916-34520  
Reamer (7 mm)



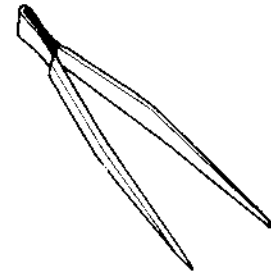
09916-37310  
Reamer (12 mm)



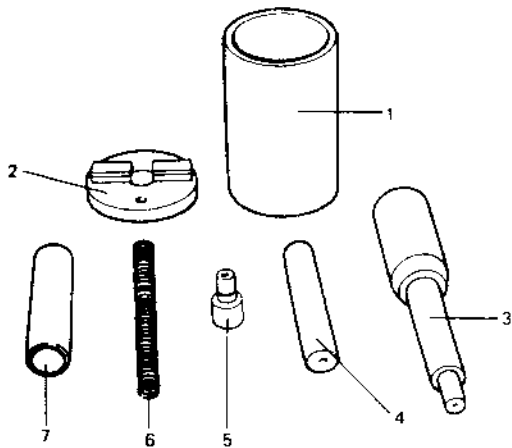
09916-34541  
Reamer handle



09916-77310  
Piston ring compressor

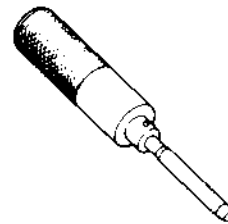


09916-84510  
Forceps

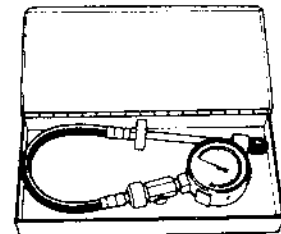


09910-38210  
Piston pin remover and installer

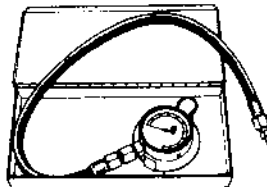
- 1. Base
- 2. Base cap
- 3. Driver handle
- 4. Piston pin guide for installation
- 5. Piston pin guide for removal
- 6. Spring
- 7. Spring guide



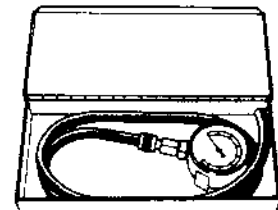
09916-57321  
Valve guide installer handle



09915-64510  
Compression gauge

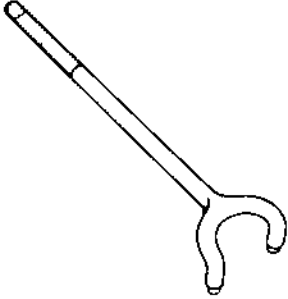
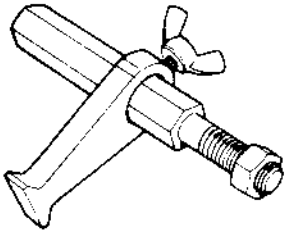
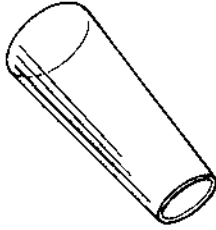

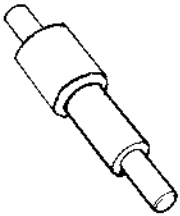
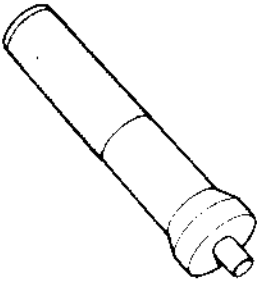
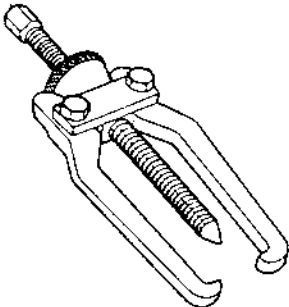
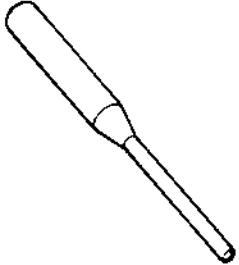
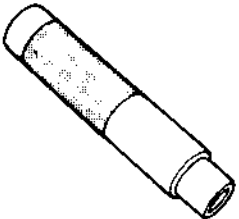
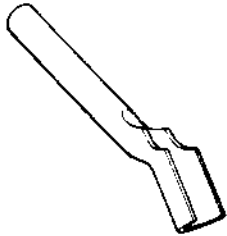
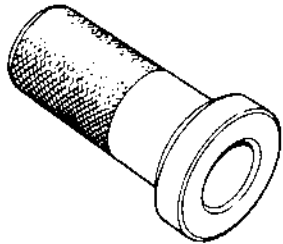
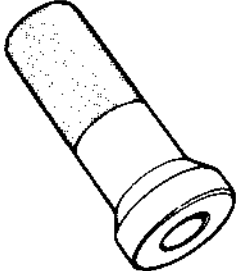
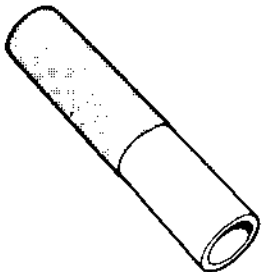
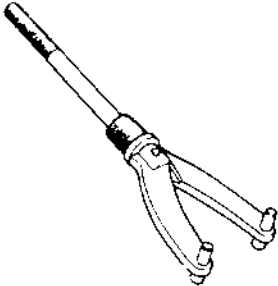
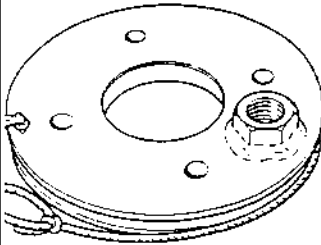



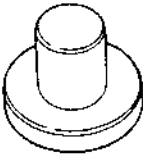
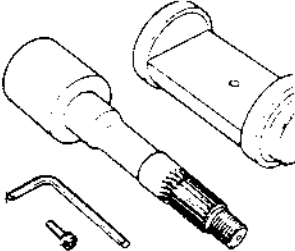
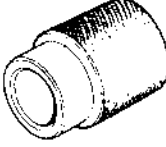
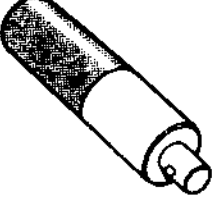

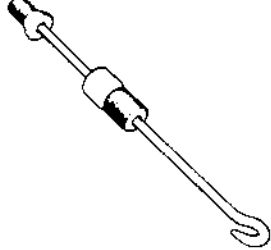
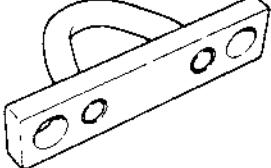
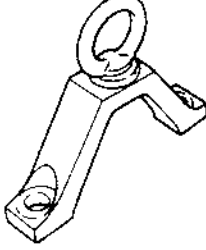
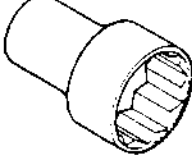
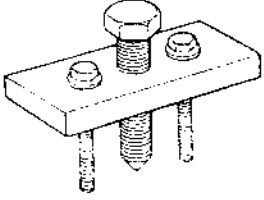
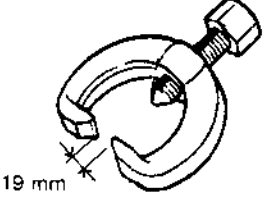
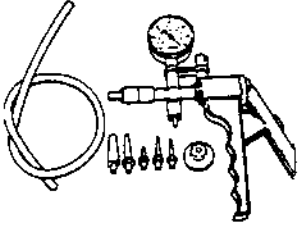

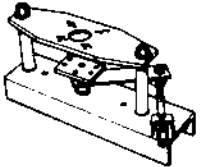
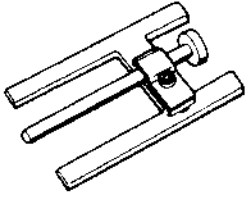

09915-77310  
Oil pressure gauge



09915-67310  
Vacuum gauge


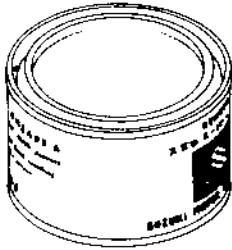




 <p>09917-68210 Camshaft lock holder</p>	 <p>09924-17810 Flywheel holder</p>	 <p>09926-18210 Oil seal guide (Vinyl resin)</p>	 <p>09917-58010 Bearing remover (for input shaft bearing)</p>
 <p>09923-38220 Clutch center guide</p>	 <p>09925-98210 Input shaft bearing installer</p>	 <p>09913-65135 Transmission and transfer bearing and gear remover</p>	 <p>09922-85811 Spring pin remover (4.5 mm)</p>
 <p>09925-18010 Transmission gear, bush and bearing installer</p>	 <p>09925-48210 Clutch release bush remover</p>	 <p>09913-75810 Transfer bearing installer</p>	 <p>09913-76010 Transfer bearing installer</p>
 <p>09913-84510 Transfer bearing installer</p>	 <p>09930-40113  <ul style="list-style-type: none"> <li>• Transfer flange lock holder</li> <li>• Differential side bearing adjuster</li> </ul> </p>	 <p>09922-75221  <ul style="list-style-type: none"> <li>• Differential bearing preload checking tool</li> </ul> </p>	 <p>09926-58010 Bearing puller attachment (transfer)</p>

 <p>09913-85230 Differential side bearing remover jig</p>	 <p>09926-78310 Differential bevel pinion mounting dummy</p>	 <p>09940-53111 Differential side bearing installer</p>	 <p>09924-74510 Bearing installer attachment</p>
 <p>09926-68310 Differential pinion bearing installer</p>	 <p>09942-15510 Sliding hammer</p>	 <p>09922-66010 Rear axle shaft remover</p>	 <p>09943-35511 Brake drum remover</p>
 <p>09941-58010 50 mm socket wrench</p>	 <p>09944-38210 Steering wheel remover</p>	 <p>09913-65210 Tie-rod end remover</p>	 <p>09917-47910 Vacuum pump gauge</p>
 <p>09950-78210 Flare nut wrench (10 mm)</p>	 <p>09950-88210 Booster overhaul tool set</p>	 <p>09950-98210 Booster piston rod gauge</p>	 <p>No. 1 09951-08210</p> <p>No. 2 09951-18210</p> <p>Booster No. 2 body Oil seal remover &amp; Installer No. 1, No. 2</p>

## 0-4. REQUIRED SERVICE MATERIALS

The materials listed below are needed for maintenance work on these cars, and should be kept on hand for ready use. In addition, such standard materials as cleaning fluids, lubricants, etc., should also be available. Methods and time of use are discussed in the text of this manual on later pages.



Ref. No.	Material		Use
1.	GOLDEN CRUISER 1200 "Anti-freeze and Summer Coolant" (99000-24120)		Additive to engine cooling system for improving cooling efficiency and for protection of wet walls against rusting.
2.	SUZUKI SUPER GREASE A (99000-25010)		<ul style="list-style-type: none"> <li>• For locations indicated in the section dealing with the starter motor.</li> <li>• Clutch release bearing retainer.</li> <li>• Clutch release shaft bushing.</li> <li>• Transmission oil seal.</li> <li>• Differential oil seal.</li> <li>• Wheel bearings.</li> <li>• Gear shifting control lever bushing &amp; seat.</li> <li>• Door window regulators.</li> <li>• For other locations specifically indicated in the text of this manual.</li> </ul>
3.	SUZUKI GREASE SUPER H (99000-25120)		Special grease intended for use on constant velocity joints.
4.	SUZUKI BOND NO. 1215 (99000-31110)		<ul style="list-style-type: none"> <li>• For top and bottom mating faces of transmission case.</li> <li>• For other locations specifically indicated in the text of this manual.</li> </ul>

5.	CHASSIS GREASE	<ul style="list-style-type: none"> <li>• For grease nipples on propeller shafts.</li> <li>• For propeller shaft splines.</li> </ul>
----	----------------	---

6.	<p><b>GEAR OIL</b> Oil Grade</p> <table border="1"> <tr> <td colspan="2"></td> <td>API GRADE</td> </tr> <tr> <td>Transmission</td> <td rowspan="2">Transfer</td> <td>GL-4 or 5</td> </tr> <tr> <td>Differential</td> <td>GL-5</td> </tr> <tr> <td></td> <td>Front</td> <td rowspan="2">GL-5</td> </tr> <tr> <td></td> <td>Rear</td> </tr> </table> <p>Viscosity chart SAE</p> <p>Temperature</p>			API GRADE	Transmission	Transfer	GL-4 or 5	Differential	GL-5		Front	GL-5		Rear	<ul style="list-style-type: none"> <li>• Transmission case 1.3 ltr. (2.7/2.3 US/Imp. pt.)</li> <li>• Transmission gear and bearing</li> <li>• Transfer case 0.8 ltr. (1.7/1.4 US/Imp. pt.)</li> <li>• Steering gear box</li> <li>• Differential gear box (Hypoid gear oil) Rear 1.5 ltr. (3.2/2.6 US/Imp. pt.) Front 2.0 ltr. (4.2/3.5 US/Imp. pt.)</li> </ul>
		API GRADE													
Transmission	Transfer	GL-4 or 5													
Differential		GL-5													
	Front	GL-5													
	Rear														

7.	SEALANT (99000-31150)	<ul style="list-style-type: none"> <li>• For mating surfaces of engine oil pan and cylinder block.</li> </ul>
----	--------------------------	---

8.	<p><b>4-STROKE ENGINE OIL</b> It is recommended to use engine oil of SE, or SF class.</p> <p><b>Proper Engine Oil Viscosity Chart</b></p> <p>Temperature</p>	<ul style="list-style-type: none"> <li>• For engine oil pan: (For periodical oil change)</li> <li>• Crank journal bearings and thrust plate.</li> <li>• Connecting-rod big-end and small-end bearings.</li> <li>• Camshaft journals.</li> <li>• Rocker shafts.</li> <li>• Oil pump gears.</li> <li>• Pistons and piston rings.</li> <li>• Engine oil seals.</li> <li>• Valve stems.</li> <li>• Accelerator and clutch cables.</li> <li>• Parking brake cable.</li> <li>• Accelerator, brake and clutch pedal shafts.</li> <li>• Door locks and hinges.</li> <li>• Distributor gear.</li> </ul>
----	--	--

9.	SEALING COMPOUND "CEMEDINE" 366E (Water tight sealant) (99000-31090) 180 ml		<ul style="list-style-type: none"> <li>• King pin shim face.</li> <li>• For steering knuckle (rear axle housing) and brake packing plate mating surface.</li> <li>• For other locations specifically indicated in the text of this manual.</li> </ul>
10.	THREAD LOCK CEMENT SUPER 1333B (99000-32020)		<ul style="list-style-type: none"> <li>• Transmission reverse gear shift rim bolt.</li> <li>• Gear shift lever locating bolt.</li> <li>• Differential drive bevel gear bolt.</li> </ul>
11.	BRAKE FLUID "DOT3"		<ul style="list-style-type: none"> <li>• To fill master cylinder reservoir.</li> <li>• To clean and apply to inner parts of master cylinder, caliper and wheel cylinder when they are disassembled.</li> </ul>
12.	SILICONE GREASE (Furnished in repair kit)		<ul style="list-style-type: none"> <li>• To apply to brake booster inner parts where application is instructed in this manual.</li> </ul>
13.	THREAD LOCK CEMENT "1342" (99000-32050)		<ul style="list-style-type: none"> <li>• King pin bolt</li> </ul>
14.	SUZUKI SUPER GREASE I (99000-25210)		<ul style="list-style-type: none"> <li>• Transmission input shaft</li> </ul>



## SECTION 1

# PERIODIC MAINTENANCE SERVICE

1

### CONTENTS

1-1.	MAINTENANCE SCHEDULE .....	1-2
1-2.	ENGINE .....	1-5
1-3.	CRANKCASE EMISSION CONTROL SYSTEM .....	1-10
1-4.	EXHAUST AND FUEL EVAPORATIVE EMISSION CONTROL SYSTEM .....	1-10
1-5.	ELECTRICAL SYSTEM .....	1-11
1-6.	IGNITION SYSTEM .....	1-11
1-7.	FUEL .....	1-13
1-8.	CHASSIS AND BODY .....	1-14

# 1-1. MAINTENANCE SCHEDULE

Interval: This interval should be judged by odometer reading or months, whichever comes first.	miles (x 1,000)		km (x 1,000)		months		7.5	15	22.5	30	37.5	45	52.5	60	67.5	75	82.5	90	97.5	105	112.5	120	
<b>ENGINE</b>																							
1. Fan (Water pump) drive belt																							
2. Camshaft timing belt																							
3. Valve lash (clearance)																							
4. Engine oil and oil filter																							
5. Cooling system hoses and connections																							
6. Engine coolant																							
7. Exhaust pipes and mountings																							
<b>CRANKCASE EMISSION CONTROL</b>																							
8. Crankcase ventilation hoses and PCV valve																							
<b>EXHAUST AND FUEL EVAPORATIVE EMISSION CONTROL</b>																							
9. Oxygen sensor																							
10. Charcoal canister storage system																							
11. Fuel vapor storage system, hoses and connections																							
<b>ELECTRICAL SYSTEM</b>																							
12. Wiring harness and connections																							
<b>IGNITION SYSTEM</b>																							
13. Spark plugs																							
14. Distributor cap and rotor																							
15. Ignition wiring																							
16. Ignition timing																							
17. Distributor advance																							

**NOTES:**

"R": Replace or change

"I": Inspect and correct or replace if necessary

"T": Tighten to the specified torque

"L": Lubricate

• Item 7 (R) is applicable to the exhaust mounting rubber only.

• Item 5 \*\*, Item 6 \*\*R and Item 7 \*\*I are recommended maintenance items.



Interval: This interval should be judged by odometer reading or months, whichever comes first.	miles (x 1,000)		km (x 1,000)		months		7.5	15	22.5	30	37.5	45	52.5	60	67.5	75	82.5	90	97.5	105	112.5	120	
							12	24	36	48	60	72	84	96	108	120	132	144	156	168	180	192	
							6	12	18	24	30	36	42	48	54	60	66	72	78	84	90	96	
<b>FUEL</b>																							
18. Fuel tank cap	-	-	-	-	-	-	-	-	**I	-	-	-	-	R	-	-	-	-	-	-	-	-	R
19. Air cleaner filter element	-	-	-	-	-	-	-	-	R	-	-	-	-	R	-	-	-	R	-	-	-	-	R
20. Thermostatically controlled air cleaner system	-	-	-	-	-	-	-	-	-	-	-	-	-	-	-	-	-	-	-	-	-	-	-
21. Choke system	-	-	-	-	-	-	-	-	I&L	-	-	-	-	I&L	-	-	-	I&L	-	-	-	-	I&L
22. Fuel filter	-	-	-	-	-	-	-	-	**R	-	-	-	-	R	-	-	-	R	-	-	-	-	R
23. Fuel lines and connections	-	-	-	-	-	-	-	-	**I	-	-	-	-	R	-	-	-	-	-	-	-	-	R
24. Idle speed	-	-	-	-	-	-	-	-	-	-	-	-	-	-	-	-	-	-	-	-	-	-	-
<b>CHASSIS AND BODY</b>																							
25. Clutch	-	-	-	-	-	-	-	-	-	-	-	-	-	-	-	-	-	-	-	-	-	-	-
26. Brake discs and pads (front)	-	-	-	-	-	-	-	-	-	-	-	-	-	-	-	-	-	-	-	-	-	-	-
26. Brake drums and shoes (rear)	-	-	-	-	-	-	-	-	-	-	-	-	-	-	-	-	-	-	-	-	-	-	-
27. Brake hoses and pipes	-	-	-	-	-	-	-	-	-	-	-	-	-	-	-	-	-	-	-	-	-	-	-
28. Brake fluid	-	-	-	-	-	-	-	-	-	-	-	-	-	R	-	-	-	-	-	-	-	-	R
29. Brake pedal	-	-	-	-	-	-	-	-	-	-	-	-	-	-	-	-	-	-	-	-	-	-	-
30. Brake lever and cable	-	-	-	-	-	-	-	-	-	-	-	-	-	-	-	-	-	-	-	-	-	-	-
31. Tires	-	-	-	-	-	-	-	-	-	-	-	-	-	-	-	-	-	-	-	-	-	-	-
32. Wheel discs and free wheeling hubs (if equipped)	-	-	-	-	-	-	-	-	-	-	-	-	-	-	-	-	-	-	-	-	-	-	-
33. Steering knuckle oil seals	-	-	-	-	-	-	-	-	R	-	-	R	-	-	R	-	-	-	R	-	-	-	R
34. Wheel bearings	-	-	-	-	-	-	-	-	-	*I	-	-	-	-	*I	-	-	-	-	-	-	-	*I
35. Shock absorbers	-	-	-	-	-	-	-	-	-	-	-	-	-	-	-	-	-	-	-	-	-	-	-
36. Propeller shafts	-	-	-	-	-	-	-	-	I&L	-	-	I&L	-	-	-	-	-	-	-	-	-	-	-
37. Transmission, transfer and differential oil	R	I	I	I	I	I	I	I	R	I	I	I	I	R	I	I	I	R	I	I	I	I	R
38. Leaf springs	-	-	-	-	-	-	-	-	-	-	-	-	-	-	-	-	-	-	-	-	-	-	-
39. Bolts and nuts	T	T	T	T	T	T	T	T	T	T	T	T	T	T	T	T	T	T	T	T	T	T	T
40. Steering system	I	I	I	I	I	I	I	I	I	I	I	I	I	I	I	I	I	I	I	I	I	I	I
41. Door hinges	L	L	L	L	L	L	L	L	L	L	L	L	L	L	L	L	L	L	L	L	L	L	L

**NOTES:**

- "R": Replace or change
- "I": Inspect or correct or replace if necessary
- "T": Tighten to the specified torque
- "L": Lubricate
- Item 18 \*I, Item 22 \*\*R and Item 23 \*\*I are recommended maintenance items.
- Item 23 R is applicable to the fuel hose and clamp only.
- Item \*24 is recommended maintenance item.
- Item 34 \*I is applicable to not only rattled wear but also their grease.

## MAINTENANCE RECOMMENDED UNDER SEVERE DRIVING CONDITIONS

If the car is usually used under the conditions corresponding to any severe condition code given below, it is recommended that applicable maintenance operation be performed at the particular interval as given in the below chart.

### Severe condition code

- |  |  |
|--|--|
| A -- Towing a trailer                    | E -- Driving in extremely cold weather and/or salted roads |
| B -- Repeated short trips                | F -- Repeated short trips in extremely cold weather        |
| C -- Driving on rough and/or muddy roads |  |
| D -- Driving on dusty roads              |  |

Severe Condition Code	Maintenance	Maintenance Operation	Maintenance Interval
A -- D E F	Engine oil and oil filter	R	Every 3 750 miles (6 000 km) or 3 months
A B C -- E --	Exhaust pipes and mountings	I	Every 7 500 miles (12 000 km) or 6 months
-- -- D --	Air cleaner filter element *1	I	Every 3 750 miles (6 000 km) or 3 months
		R	Every 15 000 miles (24 000 km) or 12 months
-- -- -- E --	Choke system (Carburetor shafts)	I & L	Every 7 500 miles (12 000 km) or 6 months
-- -- -- E --	Distributor cap and Ignition wiring *2	I	Every 15 000 miles (24 000 km) or 12 months
A B C D --	Brake discs and pads (Front) Brake drums and shoes (Rear)	I	Every 7 500 miles (12 000 km) or 6 months
A B C -- --	Propeller shafts	I & L	Every 7 500 miles (12 000 km) or 6 months
A -- C -- --	Transmission, transfer and differential oil	R	Every 15 000 miles (24 000 km) or 12 months
-- C -- --	Leaf springs	I	Every 15 000 miles (24 000 km) or 12 months
-- C -- --	Bolts and nuts on chassis	T	Every 7 500 miles (12 000 km) or 6 months
-- C -- --	Steering wheel free play, gear box oil and linkage	I	Every 3 750 miles (6 000 km) or 3 months
-- C -- E --	Steering knuckle oil seals	R	Every 15 000 miles (24 000 km) or 12 months

### NOTES:

I -- Inspect and correct or replace if necessary  
R -- Replace or change

T -- Tighten to the specified torque  
L -- Lubricate

\*1 Inspect more frequently if the vehicle is used under dusty conditions.

\*2 In areas where road salt is used, inspect and clean the distributor cap and ignition wiring more frequently.

## 1-2. ENGINE

### 1. WATER PUMP BELT INSPECTION AND REPLACEMENT

#### WARNING:

All inspection and replacement are to be performed with ENGINE NOT RUNNING.

#### [INSPECTION]

- 1) Disconnect negative battery lead at battery.
- 2) Inspect belt for cracks, cuts, deformation, wear and cleanliness. If any defect, replace. Check belt for tension. The belt is in proper tension if it deflects 6 to 9 mm (0.24 – 0.35 in.) under thumb pressure (about 10 kg or 22 lb.).

Belt tension specification	6 – 9 mm (0.24 – 0.35 in.) as deflection
----------------------------	--

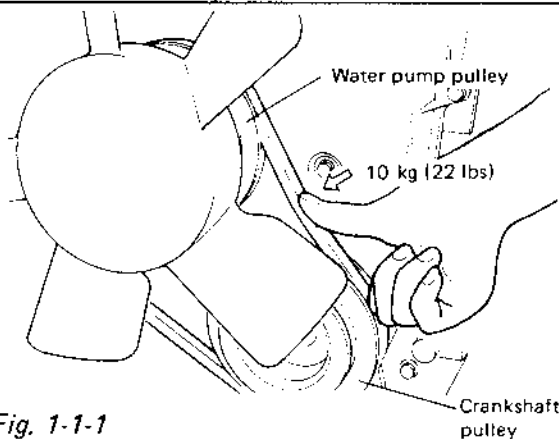


Fig. 1-1-1

- 3) If the belt is too tight or too loose, adjust it to specification by adjusting alternator position.

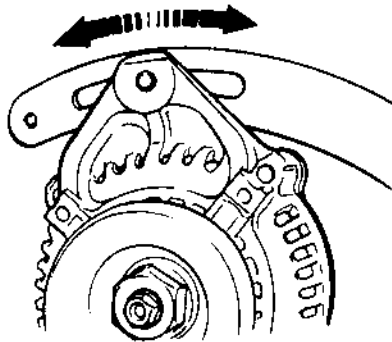


Fig. 1-1-2

- 4) Tighten alternator adjusting bolt and pivot bolts.
- 5) Connect negative battery lead to battery.

#### [REPLACEMENT]

- 1) Disconnect negative battery lead at battery.
- 2) Loosen alternator adjusting bolt and pivot bolts.
- 3) Replace water pump belt.
- 4) Adjust belt tension to specification and tighten alternator adjusting bolt and pivot bolts.
- 5) Connect negative battery lead to battery.

### 2. CAMSHAFT TIMING BELT INSPECTION

- 1) Disconnect negative battery lead at battery.
- 2) Loosen fan drive belt, and remove 4 bolts securing radiator shroud panel and 4 nuts securing engine cooling fan & clutch. Then remove radiator shroud and cooling fan & clutch at the same time.



Fig. 1-2-1

- 3) Remove water pump belt and pump pulley.
- 4) Remove crankshaft pulley by removing 4 pulley bolts. The crankshaft timing belt pulley bolt at the center need not be loosened.

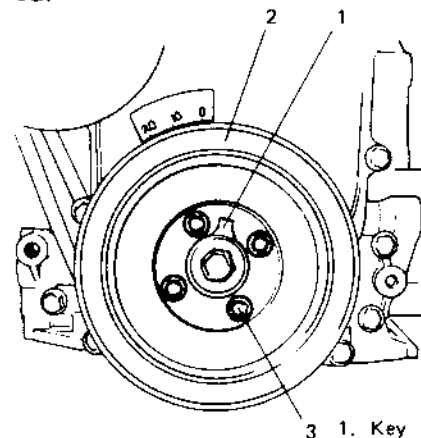


Fig. 1-2-2

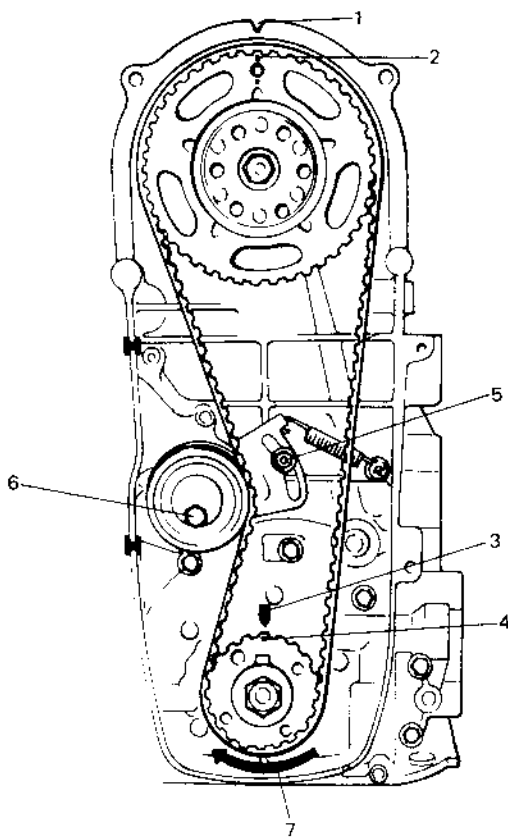
5) Remove timing belt outside cover. Inspect the belt for damage or wear. When any damage or wear is found on the belt, replace it.

If belt replacement is necessary, be sure to install the belt properly, referring to p. 3-48 to p. 3-51 for installation procedure.

6) Remove cylinder head cover and loosen all valve adjusting screws all the way to permit free rotation of camshaft.

7) Turn crankshaft clockwise and align 4 marks as shown.

Loosen tensioner bolt and nut but do not remove.



- 1. "V" mark
- 2. Timing mark
- 3. Arrow mark
- 4. Punch mark
- 5. Tensioner nut
- 6. Tensioner bolt
- 7. Turning direction

Fig. 1-2-3

8) To allow belt to be free of any slack, turn crankshaft clockwise fully twice. After removing belt slack, tighten tensioner nut to 9 – 12 N·m (0.9 – 1.2 kg·m, 7.0 – 8.5 lb·ft) first and then tensioner bolt to 24 – 30 N·m (2.4 – 3.0 kg·m, 17.5 – 21.5 lb·ft). Then confirm again that 4 marks are matched.

- 9) Adjust valve lash to specification referring to 3-53 of SECTION 3.
- 10) Install cylinder head cover and torque bolt to specification. (Refer to p. 3-58 for torque data).
- 11) Install timing belt outside cover and torque bolts and nut to specification. (Refer to p. 3-58 for torque data.)
- 12) Install crankshaft pulley and torque bolts to specification. (Refer to p. 3-58 for torque data.)
- 13) Install water pump pulley and belt.
- 14) Install radiator shroud and cooling fan & clutch.
- 15) Adjust water pump belt tension to specification. (Refer to p. 1-5)
- 16) Connect negative battery lead to battery.

### 3. VALVE LASH INSPECTION

- 1) Remove cylinder head cover.
- 2) Inspect intake and exhaust valve lash and adjust as necessary.

Valve lash (gap A) specification	When cold (Coolant temperature is 15 – 25°C or 59 – 77°F)	When hot (Coolant temperature is 60 – 68°C or 140 – 154°F)
Intake	0.13 - 0.17 mm (0.0051 - 0.0067 in)	0.23 - 0.27 mm (0.009 - 0.011 in)
Exhaust	0.16 - 0.20 mm (0.0063 - 0.0079 in)	0.26 - 0.30 mm (0.0102 - 0.0118 in)

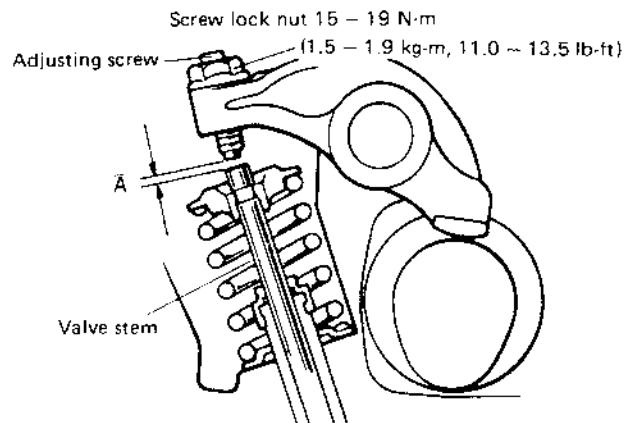


Fig. 1-3-1

- 3) Refer to 3-53 of SECTION 3 for valve lash inspection and adjustment procedures.
- 4) Install cylinder head cover and tighten bolts to specification. (Refer to p. 3-58)

#### 4. ENGINE OIL AND FILTER CHANGE

Before draining engine oil, check engine for oil leakage. If any evidence of leakage is found, make sure to correct defective part before proceeding to the following work.

- 1) Drain engine oil by removing drain plug.

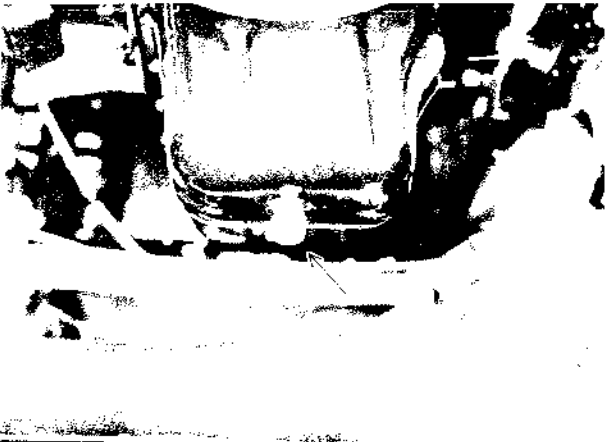


Fig. 1-4-1

- 2) After draining oil, wipe drain plug clean. Reinstall drain plug, and tighten it securely.

Tightening torque	N·m	kg·m	lb·ft
for oil drain plug	30-40	3.0-4.0	22.0-28.5

- 3) Loosen oil filter by using oil filter wrench "A" (special tool 09915-47310).



Fig. 1-4-2

#### NOTICE:

Before fitting new oil filter, be sure to oil its "O" ring. Use engine oil for this purpose.

- 4) Screw new filter on oil filter stand by hand until the filter "O" ring contacts the mounting surface.

#### CAUTION:

To tighten the oil filter properly, it is important to accurately identify the position at which the filter "O" ring first contacts the mounting surface.

- 5) Tighten the filter 3/4 turn from the point of contact with the mounting surface using an oil filter wrench "A".

Oil filter tightening torque  
 12-16N·m  
 1.2-1.6kg·m  
 8.5-11.5lb·ft

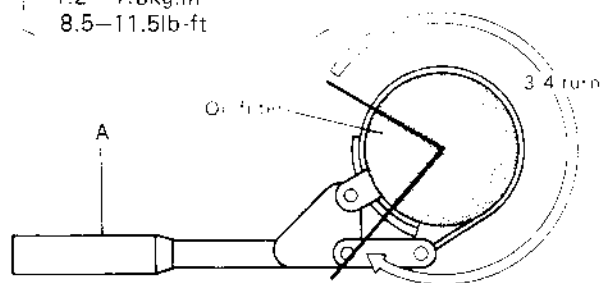


Fig. 1-4-3

- 6) Replenish oil until oil level is brought to FULL level mark on dipstick. (about 3.7 liters or 7.8/6.5 US/Imp pt.). The filler inlet is atop the cylinder head cover.
- 7) Start engine and run it for three minutes. Stop engine and wait another three minutes before checking oil level. Add oil, as necessary, to bring oil level to FULL level mark on dipstick.

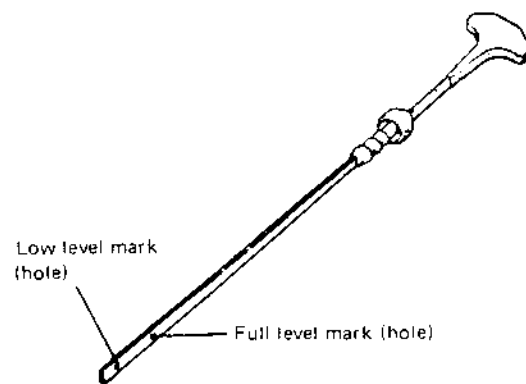


Fig. 1-4-4

**NOTICE:**

Steps 1) – 6) outlined above must be performed with **ENGINE NOT RUNNING**. For step 7), be sure to have adequate ventilation while engine is running.

It is recommended to use engine oil of SE or SF class.

**NOTICE:**

For temperatures below 32° F (0° C), it is highly recommended to use SAE 5W-30 oil.

**Proper Engine Oil Viscosity Chart**

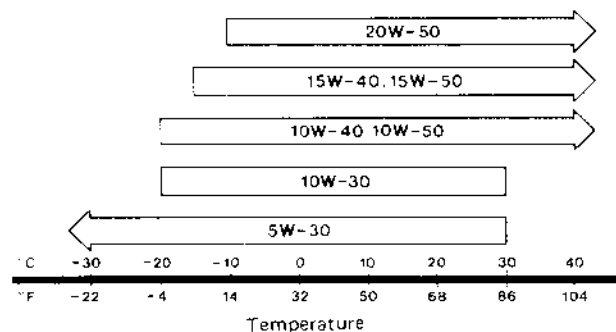


Fig. 1-4-5 Engine Oil Viscosity Chart

**Engine oil capacity**

Oil pan capacity	3.5 liters (7.4/6.2 US/Imp pt.)
Oil filter capacity	0.2 liters (0.4/0.3 US/Imp pt.)
Others	0.3 liters (0.6/0.5 US/Imp pt.)
Total	4.0 liters (8.4/7.0 US/Imp pt.)

8) Check oil filter and drain plug for oil leakage.

**5. COOLING SYSTEM HOSES AND CONNECTIONS INSPECTION**

1) Visually inspect cooling system hoses for any evidence of leakage and cracks. Examine them for damage, and check connection clamps for tightness.

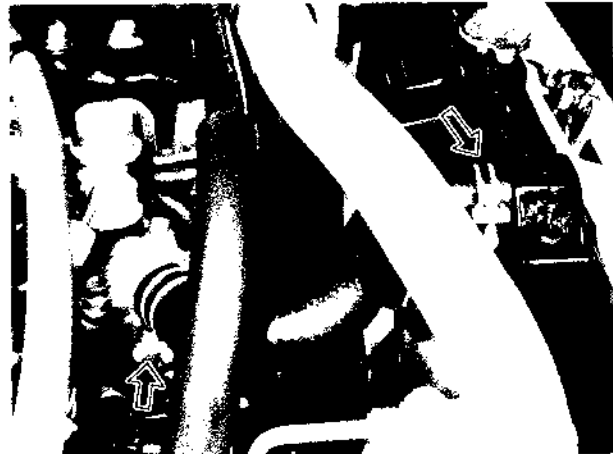


Fig. 1-5-1

2) Replace all hoses which show evidence of leakage, cracks or other damage. Replace all clamps which cannot maintain proper tightness.

**6. ENGINE COOLANT CHANGE**

**IMPORTANT:**  
To help avoid danger of being burned, do not remove radiator cap while engine and radiator are still hot. Scalding fluid and steam can be blown out under pressure if the cap is taken off too soon.

- 1) Remove radiator cap when engine is cool.
- 2) Loosen radiator drain plug ① to drain coolant.
- 3) Remove reservoir tank ②, which is on the side of radiator, and drain.
- 4) Tighten plug ① securely. Also reinstall reservoir tank.

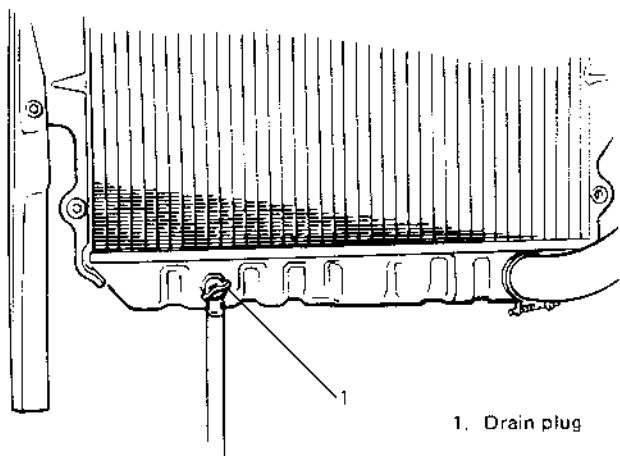


Fig. 1-6-1

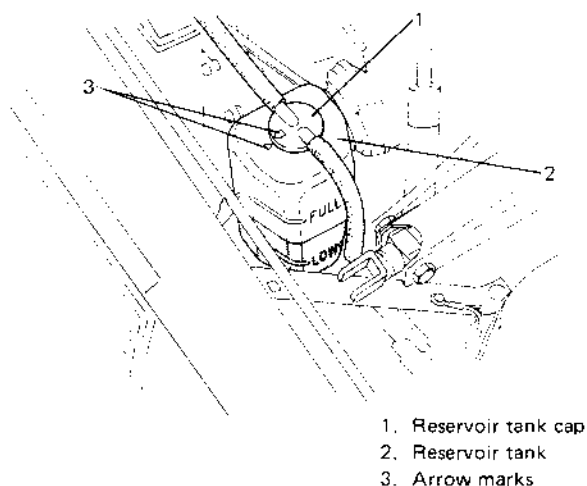


Fig. 1-6-2

- 5) Fill radiator with specified amount of coolant, and run engine for 2 or 3 minutes at idle. This drives out any air which may still be trapped within cooling system. STOP ENGINE. Add coolant as necessary until coolant level reaches the filler throat of radiator. Reinstall radiator cap.
- 6) Add coolant to reservoir tank so that the level aligns with Full mark. Then, reinstall cap aligning the arrow marks on the tank and cap.

COOLANT CAPACITY	
Engine, radiator and heater	4.4 liters (9.3/7.7 US/Imp pt.)
Reservoir tank	0.6 liters (1.3/1.1 US/Imp pt.)
Total	5.0 liters (10.6/8.8 US/Imp pt.)

**CAUTION:**

When changing engine coolant, use mixture of 50% water and 50% GOLDEN CRUISER 1200 for the market where ambient temperature falls lower than  $-16^{\circ}\text{C}$  ( $3^{\circ}\text{F}$ ) in winter and mixture of 70% water and 30% GOLDEN CRUISER 1200 for the market where ambient temperature doesn't fall lower than  $-16^{\circ}\text{C}$  ( $3^{\circ}\text{F}$ ).

Even in a market where no freezing temperature is anticipated, mixture of 70% water and 30% GOLDEN CRUISER 1200 should be used for the purpose of corrosion protection and lubrication.

**7. EXHAUST PIPES AND MOUNTINGS INSPECTION**

**IMPORTANT:**

To avoid danger of being burned, do not touch exhaust system when system is hot. Any service on exhaust system should be performed when system is cool.

When carrying out periodic maintenance, or the car is raised for other service, check exhaust system as follows:

- Check rubber mountings for damage, deterioration, and out of position.
- Check exhaust system for leakage, loose connections, dents, and damages. If bolts or nuts are loose, tighten them to specification. Refer to below chart for torque specification.
- Check nearby body areas for damaged, missing, or mispositioned parts, open seams, holes, loose connections or other defects which could permit exhaust fumes to seep into the car.
- Make sure that exhaust system components have enough clearance from the underbody to avoid overheating and possible damage to the floor carpet.
- Any defects should be fixed at once.

Bolts and nut	Tightening torque
Exhaust pipe bolts	40 – 60 N·m
	4.0 – 6.0 kg·m 29.0 – 43.0 lb·ft
Muffler nuts	18 – 28 N·m
	1.8 – 2.8 kg·m
	13.5 – 20.0 lb·ft

Replace center pipe rubber mounting and muffler rubber mountings with new ones periodically.

### 1-3. CRANKCASE EMISSION CONTROL SYSTEM

#### 8. CRANKCASE VENTILATION HOSES AND PCV VALVE REPLACEMENT

- 1) Disconnect crankcase ventilation hoses from cylinder head cover, PCV valve, air cleaner case and 3 way joint.
- 2) Remove PCV valve from intake manifold.
- 3) Wind sealing tape on thread of the new valve and install it securely.

Tightening torque for PCV valve	15 – 25 N·m
	1.5 – 2.5 kg·m
	11.0 – 18.0 lb·ft

- 4) Install new hoses and clamp them securely.

### 1-4. EXHAUST AND FUEL EVAPORATIVE EMISSION CONTROL SYSTEM

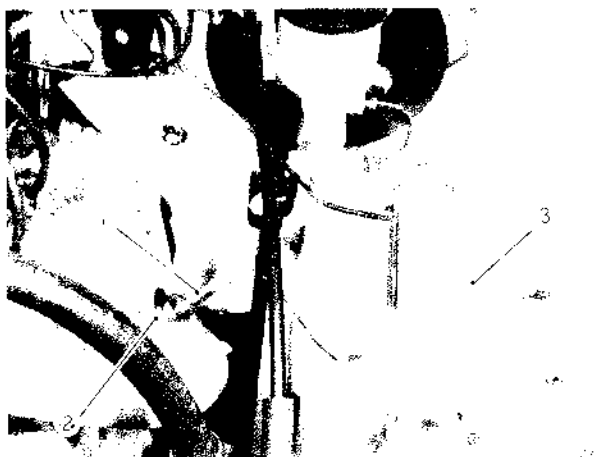
#### 9. OXYGEN SENSOR REPLACEMENT

As "SENSOR" lamp on instrument panel flashes automatically at every 60,000 miles when running warmed up engine, replace oxygen sensor as follows.

#### CAUTION:

To avoid the danger of being burned, do not touch the exhaust system when the system is hot. This work should be performed when the system is cool.

- 1) Disconnect battery negative cable from battery and disconnect oxygen sensor wire at the coupler.



1. Oxygen sensor      3. Coupler  
2. Exhaust manifold

Fig. 1-9-1

- 2) Remove oxygen sensor from exhaust manifold.
- 3) Install new gasket and oxygen sensor, and tighten it to specification.

Tightening torque for oxygen sensor	45 – 55 N·m
	4.5 – 5.5 kg·m
	33.0 – 39.5 lb·ft

- 4) Connect oxygen sensor wire at the coupler securely and clamp its wire.
- 5) Connect negative cable to battery.
- 6) Start engine and check for gas leak.
- 7) Run engine at 1,500 ~ 2,000 r/min for 30 sec. after warming up engine. Check to be sure that "SENSOR" lamp flashes, and turn off "SENSOR" lamp cancel switch on steering column holder bracket. Refer to p. 5-23 of SECTION 5.

#### 10. CHARCOAL CANISTER INSPECTION

Refer to MAINTENANCE SERVICE (p. 5-20) of SECTION 5 for charcoal canister inspection.

#### 11. FUEL VAPOR STORAGE SYSTEM, HOSES AND CONNECTIONS REPLACEMENT

#### IMPORTANT:

The following cautions should be always observed.

- Disconnect negative cable at battery.
- DO NOT smoke and place "NO SMOKING" signs near work area.
- Be sure to have CO<sub>2</sub> fire extinguisher handy.
- Wear safety glasses.
- To release the fuel vapor pressure in fuel tank, remove the fuel tank cap and then reinstall it.



- 1) Replace hoses (pipe to canister, canister to intake manifold and canister to carburetor) with new ones.
- 2) Remove pipe upper and lower protector.
- 3) Replace hoses (pipe to separator and separator to tank) with new ones.
- 4) Inspect the clamps for damage and proper position. Replace or correct the clamps if necessary.
- 5) Install pipe upper and lower protector.

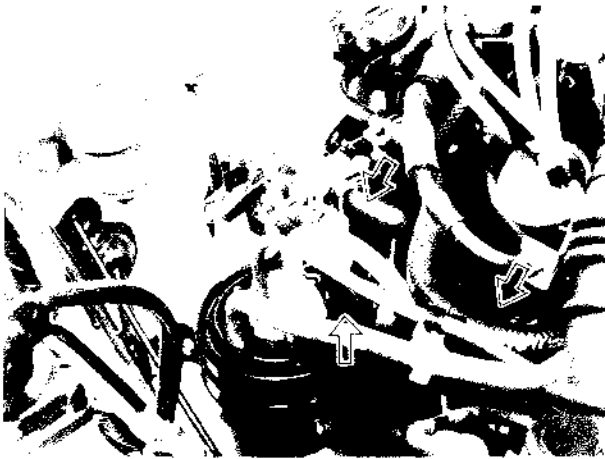


Fig. 1-11-1

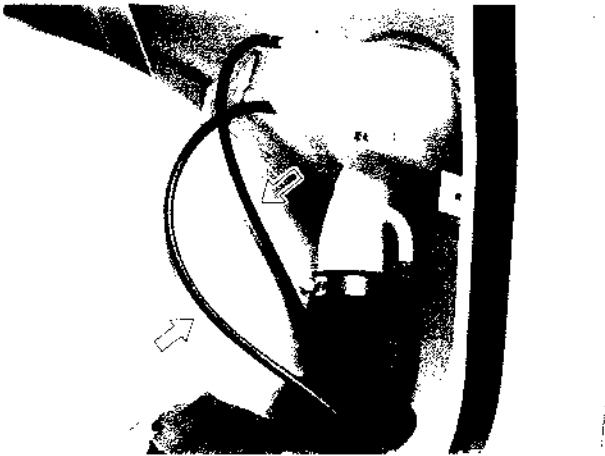


Fig. 1-11-2

## 1-5. ELECTRICAL SYSTEM

### 12. WIRING HARNESS AND CONNECTIONS INSPECTION

- 1) Visually inspect all wires located in engine compartment for evidence of breakage. Inspect the condition of the insulation (cracks). All clips and clamps should have solid connections to wires.
- 2) Replace any wires in a deteriorated or otherwise defective condition.

## 1-6. IGNITION SYSTEM

### 13. SPARK PLUGS REPLACEMENT

- 1) Disconnect high-tension cords from spark plugs. Make sure to pull only on spark plug caps.

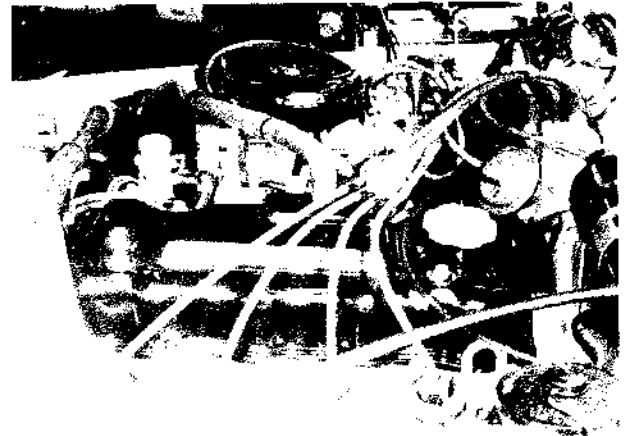


Fig. 1-13-1

- 2) Using a spark plug wrench, loosen and remove plugs.

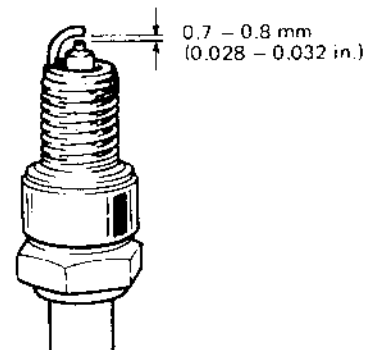


Fig. 1-13-2

**NOTICE:**

When replacing plugs, make sure to use new plugs of specified heat range and size.

**PLUG SPECIFICATION**

Maker	Heat range Standard type
NGK	BPR5ES
Nippon Denso	W16EXR-U

- 3) Install new spark plugs. Tighten plugs to specification.
- 4) Connect high tension cords to spark plugs. DO NOT push cords for connection. Push boots.

Spark plug tightening torque	20 – 30 N·m 2.0 – 3.0 kg·m 14.5 – 21.5 lb·ft
---------------------------------	--

**14. DISTRIBUTOR CAP AND ROTOR INSPECTION**

- 1) Inspect distributor cap and rubber caps for cracks.
- 2) Inspect center electrode and terminals for wear.

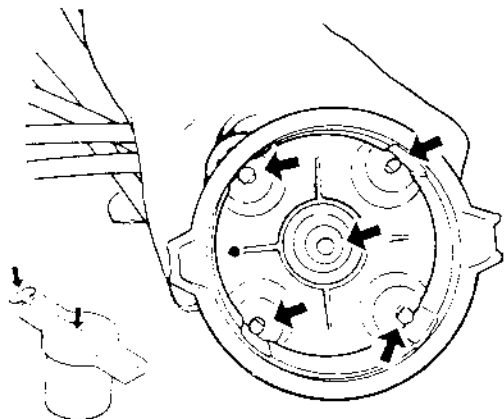


Fig. 1-14-1

- 3) Inspect rotor for cracks, and its electrode for wear.
- 4) Check to see that there are no excessive closes in ventilation plug hole.
- 5) Repair or replace as necessary any component which is found to be in malcondition as described above.

**NOTICE:**

Dust and stains found within distributor can be cleaned by using a dry, soft cloth.

**15. IGNITION WIRING REPLACEMENT**

- 1) Disconnect high tension cords from spark plugs, ignition coil and distributor.
- 2) Connect new high tension cords as shown and clamp them securely. DO NOT push cords for connection. Push boots.

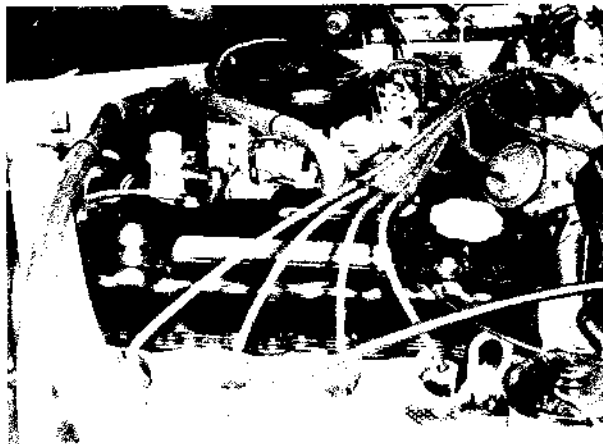


Fig. 1-15-1

**16. IGNITION TIMING INSPECTION**

Check to make sure that ignition timing is set properly. If out of specification, adjust it. Refer to p. 8-9 of SECTION 8 for inspection and adjustment procedure.

**17. DISTRIBUTOR ADVANCER INSPECTION**

Check advancer for proper operation. Refer to p. 8-9 of SECTION 8 for checking procedure. Check vacuum hose for pinhole, crack or brake. Correct or replace if necessary.

## 1-7. FUEL

### 18. FUEL TANK CAP GASKET INSPECTION AND REPLACEMENT

Visually inspect gasket of fuel tank cap. If it is damaged or deteriorated, replace it with new one.

### 19. AIR CLEANER ELEMENT REPLACEMENT

- 1) Remove air cleaner cap.
- 2) Take cleaner element ① out of air cleaner case.
- 3) Install new cleaner element ① into cleaner case.

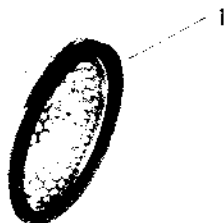


Fig. 1-19-1

- 4) Install air cleaner cap securely.

### 20. THERMOSTATICALLY CONTROLLED AIR CLEANER SYSTEM INSPECTION

Check thermostatically controlled air cleaner system for proper operation. Refer to p. 5-19 of SECTION 5 for checking procedure.

### 21. CARBURETOR CHOKE SYSTEM LUBRICATION AND INSPECTION

- 1) Remove air intake case, and lubricate rotating parts.
- 2) Check choke for proper operation, referring to CHOKE INSPECTION in MAINTENANCE SERVICE (p. 4-22) of SECTION 4.

## 22. FUEL FILTER REPLACEMENT

#### WARNING:

This work must be performed in a well ventilated area and away from any open flames (such as gas hot water heaters).

- 1) Disconnect negative cable from battery.
- 2) Remove fuel tank cap to release fuel vapor pressure in fuel tank. After releasing, reinstall the cap.
- 3) Disconnect inlet and outlet hoses from fuel filter located at the front part of fuel tank, inside the right-hand side of chassis.
- 4) Remove fuel filter with clamp.
- 5) Install new filter with clamp, and connect inlet and outlet hoses to fuel filter.

#### NOTICE:

The top connection is for the outlet hose, the lower one for the inlet hose.

- 6) Connect negative cable to battery.
- 7) After installation, start engine and check it for leaks.

## 23. FUEL LINES AND CONNECTIONS INSPECTION AND REPLACEMENT

#### [INSPECTION]

Visually inspect fuel lines and connections for evidence of fuel leakage, hose cracking, and damage. Make sure all clamps are secure. Repair leaky joints, if any.

Replace hoses that are suspected of being cracked.

#### [REPLACEMENT]

#### IMPORTANT:

The following cautions should be always observed.

- Disconnect negative cable at battery.
- DO NOT smoke and place "NO SMOKING" signs near work area.
- Be sure to have CO<sub>2</sub> fire extinguisher handy.
- Wear safety glasses.
- To release the fuel vapor pressure in fuel tank, remove the fuel tank cap and then reinstall it.

- 1) Replace fuel hoses (pipe to fuel pump, pipe to fuel filter and breather hose) in fuel feed and return lines with new ones.
- 2) Remove fuel tank referring to p. 4-34 of SECTION 4.
- 3) Replace return hose (tank to return pipe) with new one.
- 4) Clamp hoses securely.
- 5) Install fuel tank referring to p. 4-35 of SECTION 4.
- 6) After installation, start engine and check it for leaks.

#### 24. IDLE SPEED INSPECTION

Check idle speed, and adjust it as necessary. Refer to MAINTENANCE SERVICE (p. 4-26) of SECTION 4 for procedures to check and adjust idle speed.

### 1-8. CHASSIS AND BODY

#### 25. CLUTCH PEDAL INSPECTION

- 1) Check clutch pedal height. It should be the same as brake pedal height.
- 2) Check clutch pedal free travel.

Clutch pedal free travel	20 – 30 mm (0.8 – 1.1 in.)
--------------------------	-------------------------------

For the details of the above steps 1) and 2), refer to MAINTENANCE SERVICE (p. 11-8) of SECTION 11.

#### 26. BRAKE DISCS, PADS, BRAKE DRUMS AND SHOES INSPECTION

##### Brake Discs and Pads

- 1) Remove wheel and caliper but don't disconnect brake hose from caliper.
- 2) Check front disc brake pads and discs for excessive wear, damage and deflection. Replace parts as necessary. For the details, refer to p. 19-16 and 19-17 of SECTION 19.

Be sure to torque caliper guide pins to specification for reinstallation.

##### Brake Drums and Shoes

- 1) Remove wheel and brake drum.
- 2) Check rear brake drums and brake linings for excessive wear and damage, while wheels and drums are removed. Also check wheel cylinders for leaks, at the same time. Replace these parts as necessary.

For the details, refer to p. 19-21 and p. 19-22 of SECTION 19.

#### 27. BRAKE HOSES AND PIPES INSPECTION

Check brake hoses and pipes for proper hook-up, leaks, cracks, chafing and other damage. Replace any of these parts as necessary.

##### CAUTION:

After replacing any brake pipe or hose, be sure to carry out air purge operation.

## 28. BRAKE FLUID INSPECTION AND CHANGE

### [INSPECTION]

- 1) Check around master cylinder and reservoir for fluid leakage.  
If found leaky, correct.
- 2) Check fluid level  
If fluid level is lower than the minimum level of reservoir, refilling is necessary. Fill reservoir with specified brake fluids.

Brake fluid	Specifications
	DOT 3

For the details, refer to MAINTENANCE SERVICE (p. 19-42) of SECTION 19.

### CAUTION:

Since the brake system of this car is factory-filled with glycol-base brake fluid, do not use or mix different type of fluid when refilling the system; otherwise serious damage will occur. Do not use old or used brake fluid, or one taken from unsealed container.

### [CHANGE]

- 1) Change brake fluid. As fluid change procedure, drain existing fluid from brake system completely, fill the system with above recommended fluid and carry out air purge operation.

For description of air purge, refer to p. 19-46 and 19-47 of SECTION 19.

## 29. BRAKE PEDAL INSPECTION

Check brake pedal travel.

For checking procedure, refer to PEDAL TRAVEL CHECK (p. 19-43) of SECTION 19.

## 30. BRAKE LEVER AND CABLE INSPECTION

### Parking Brake Lever

- 1) Check tooth tip of each notch for damage or wear. If any damage or wear is found, replace parking lever.
- 2) Check parking brake lever for proper operation and stroke, and adjust it if necessary.  
For checking and adjusting procedures, refer to PARKING BRAKE INSPECTION AND ADJUSTMENT (p. 19-44) of SECTION 19.

### Parking Brake Cable

Inspect brake cable for damage and smooth movement. Replace cable if it is in deteriorated condition.

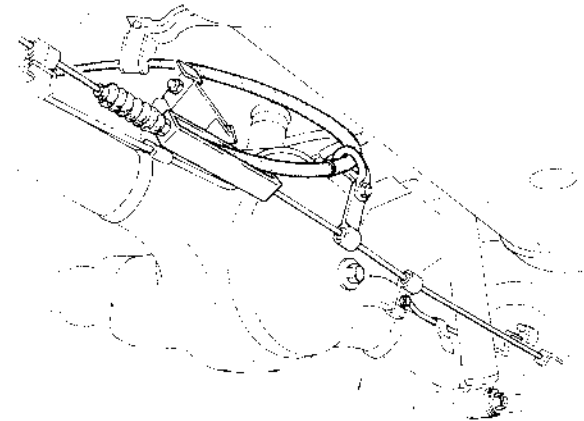


Fig. 1-30-1

## 31. TIRE INSPECTION AND ROTATION

- 1) Check tires for uneven or excessive wear, or damage. If defective, replace.
- 2) Check inflating pressure of each tire and adjust pressure to specification as necessary.

### NOTICE:

- Tire inflation pressure should be checked when tires are cool.
- Specified tire inflation pressure should be found on tire placard or in owners' manual which came with the car.

- 3) Rotate tires.

For the details of above steps 1) to 3), refer to MAINTENANCE SERVICE (p. 18-19 and 18-20) of SECTION 18.

### 32. WHEEL DISCS AND FREE WHEELING HUBS (if equipped) INSPECTION

#### Wheel Discs

Inspect each wheel disc for dents, distortion and cracks. A disc in badly damaged condition must be replaced.

#### Free Wheeling Hub

This is applicable to the car equipped with free wheeling hubs.

Check free wheeling hub for proper operation by moving free wheeling hub knob to LOCK and FREE positions. (The same check on both right and left wheels)

For checking procedure, refer to MAINTENANCE SERVICE (p. 17-29) of SECTION 17.

### 33. STEERING KNUCKLE OIL SEAL REPLACEMENT

For replacement procedure, refer to MAINTENANCE SERVICE (p. 17-23) of SECTION 17.

### 34. WHEEL BEARING INSPECTION

[Inspection of wheel bearing]

- 1) Check front wheel bearing for wear, damage, abnormal noise or rattles. For the details, refer to MAINTENANCE (p. 17-20 and 17-21) of SECTION 17.
- 2) Check rear wheel bearing for wear, damage abnormal noise or rattles. For the details, refer to MAINTENANCE SERVICE (p. 17-24) of SECTION 17.

[Inspection of front wheel bearing grease]

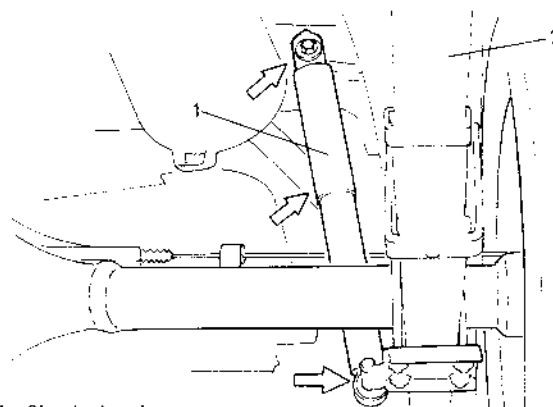
- 1) Remove wheel hub and spindle referring to FRONT WHEEL HUB REMOVAL of SECTION 17.
- 2) Check grease around front wheel bearing rollers and between front axle shaft surface and wheel spindle bush for deterioration and capacity.

If grease is deteriorated, remove grease thoroughly and apply enough amount of new SUZUKI SUPER GREASE A or wheel bearing grease. If grease is found insufficient, add some more.

- 3) Install spindle, bearings, wheel hub, bearing nut and brake disc referring to INSTALLATION (p. 17-12) of SECTION 17.
  - 4) Adjust bearing preload and then tighten bearing lock nut to specification. Refer to MAINTENANCE (p. 17-21) of SECTION 17.
  - 5) Install drive flange or free wheeling hub (if equipped), brake caliper with mounting and wheel referring to INSTALLATION (p. 17-12) of SECTION 17.
- For tightening torque of each bolt and nut, refer to torque table (p. 17-26) of SECTION 17.

### 35. SHOCK ABSORBERS INSPECTION

- 1) Inspect absorbers for evidence of oil leakage, dents or any other damage on sleeves; and inspect anchor ends for deterioration.
- 2) Depending on the results of the above inspection, replace absorbers.



1. Shock absorber
2. Leaf spring

Fig. 1-35-1

#### WARNING:

When handling rear shock absorber in which high-pressure gas is sealed, make sure to observe the following precautions.

1. Don't disassemble it.
2. Don't put it into fire.
3. Don't store it where it gets hot.
4. Before disposing it, be sure to drill a hole in it where shown in the illustration below and let gas and oil out. Lay it down sideways for this work.

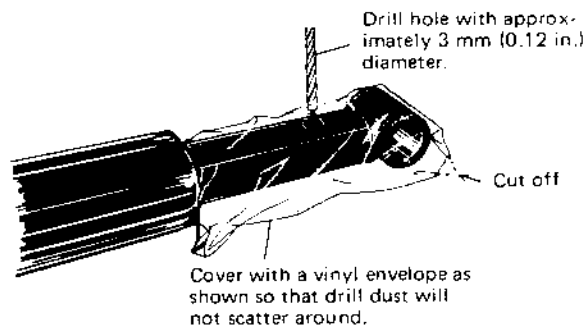


Fig. 1-35-2

### 36. PROPELLER SHAFTS INSPECTION AND LUBRICATION

#### 1) Lubricate propeller shaft.

The nipple for lubrication is located on each sliding yoke. Be sure to use chassis grease.



Fig. 1-36-1

#### 2) Check universal joint and spline of propeller shaft for rattle. If rattle is found, replace defective part with a new one.

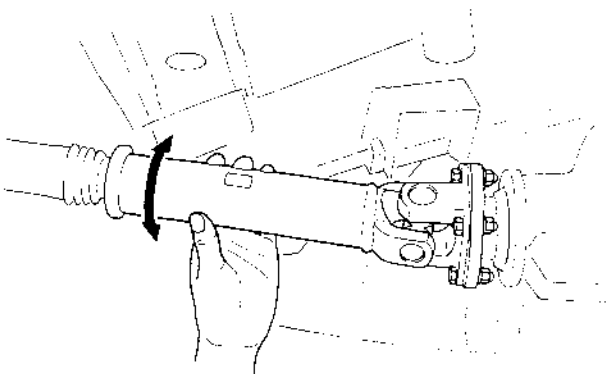


Fig. 1-36-2

#### 3) Check propeller shaft (No. 1, No. 2, No. 3) flange yoke bolts for tightness, and retighten them as necessary:

Tightening torque	N·m	kg·m	lb·ft
	23 - 30	2.3 - 3.0	17.0 - 21.5

### 37. TRANSMISSION, TRANSFER, DIFFERENTIAL OIL INSPECTION AND CHANGE

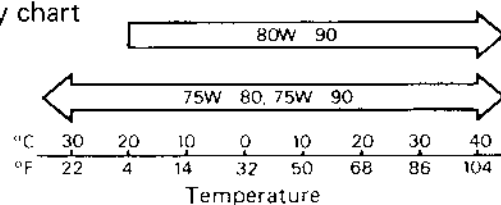
#### [Inspection]

- 1) Inspect transmission case, transfer case and differential housing for evidence of oil leakage. Repair leaky point if any.
- 2) Make sure that the car is placed level for oil level check.
- 3) Remove each level plug of transmission, transfer and differential (front and rear). In any of these cases, oil level can be checked roughly by means of level plug hole. That is, if oil flows out of level plug hole or if oil level is found up to hole when level plug is removed, oil is properly filled. If oil is found insufficient, pour specified amount of specified oil as given in the below table.

#### [Change]

Oil change procedure is as follows. Place the car level and drain oil by removing drain plug. Pour specified amount of specified oil as in the below table and tighten drain plug and filler plug to specified torque. It is highly recommended to use SAE 75W-90 gear oil.

#### Viscosity chart SAE



#### Transmission oil change

Oil capacity	1.3 liters (2.7/2.3 US/Imp pt.)
Type of oil	Gear oil, SAE 80W-90, 75W-80 or 75W-90

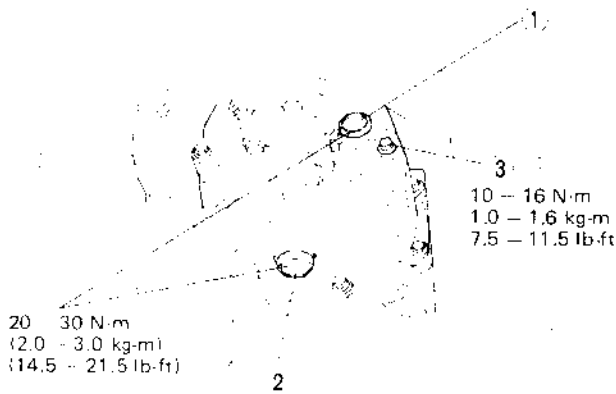


Fig. 1-37-1

- 1. Oil filler plug
- 2. Oil drain plug
- 3. Oil level plug

Transfer oil change

Oil capacity	0.8 liters (1.7/1.4 US/Imp. pt.)
Type of oil	Gear oil SAE 80W-90, 75W-80 or 75W-90

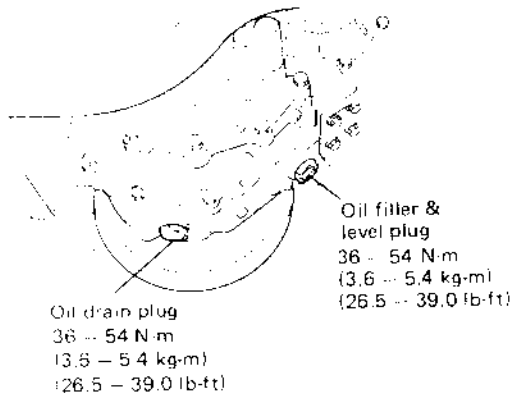


Fig. 1-37-2

Differential oil change (Front and rear)

	Front	Rear
Oil capacity	2.0 liters (4.2/3.5 US/Imp pt.)	1.5 liters (3.2/2.6 US/Imp pt.)
Type of oil	Hypoid gear oil, SAE 80W-90, 75W-80 or 75W-90	

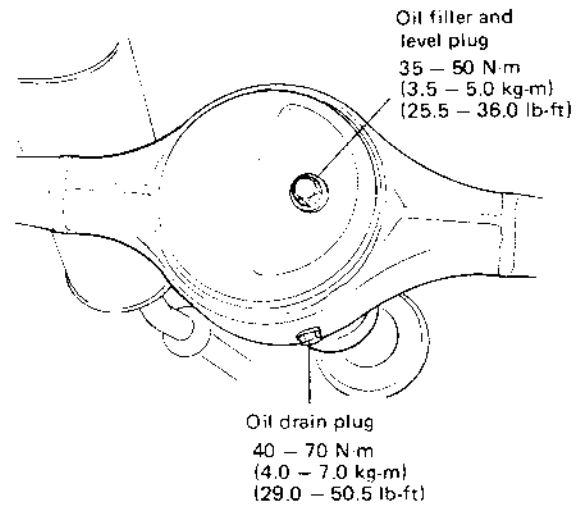


Fig. 1-37-3

38. LEAF SPRING INSPECTION

Check leaf spring for wear, crack and damage. (Where each end of the shorter leaf contacts.) If excessive wear or cracking is noted, replace the spring with a new one.

39. BOLTS AND NUTS TIGHTENING

Check suspension bolts and nuts for tightness and retighten them as necessary. Repair or replace defective parts, if any.

NOTICE:

For the details of check points, refer to the table of MAINTENANCE SERVICE (p. 17-24) of SECTION 17.

40. STEERING SYSTEM INSPECTION

- 1) Check steering wheel for play and rattle, holding car in straight forward condition on the ground.

Steering wheel play	10 - 30 mm (0.4 - 1.2 in.)
---------------------	-------------------------------

- 2) Check universal joint and rubber joint of steering shaft for rattle and damage. If rattle or damage is found, replace defective part with a new one.



3) Check bolts and nuts for tightness and retighten them as necessary. Repair or replace defective parts, if any.

Refer to MAINTENANCE SERVICE on p. 18-18 for particular check points.

4) Inspect steering gear box for evidence of oil leakage. If leakage is found, check oil level in gear box.

**NOTICE:**

For the details of the above steps 1) to 4), refer to MAINTENANCE SERVICE (p. 18-18) of SECTION 18.

5) Check boots of tie rod ends for damage. If damage is found, replace it with a new one.

6) Check wheel alignment.

Alignment service data

Side slip	OUT 0 – IN 3 m/km
Toe-in	2 – 6 mm (0.079 – 0.236 in.)
Camber	1 degree (1°) ± 45'
Kingpin inclination	9 degrees (9°) ± 2°
Caster	3 degrees 30 minutes (3° 30') ± 1°

**NOTICE:**

For the details of wheel alignment, refer to WHEEL ALIGNMENT (p. 18-16) of SECTION 18.

#### 41. DOOR HINGES LUBRICATION

Lubricate door hinges for smooth operation.

#### 42. FINAL INSPECTION

Carry out road test in safe place.

**WARNING:**

When carrying out the following road tests, select a safe place where no man or no running car is seen so as to prevent any accident.

##### 1) Engine start

Check engine start for readiness.

##### 2) Clutch

Check the following:

- that clutch is completely released when depressing clutch pedal,
- that no slipping clutch occurs when releasing pedal and accelerating,
- and that clutch itself is free from any abnormal condition.

##### 3) Gearshift Lever (Transmission and Transfer)

Check gearshift lever for smooth shifting to all positions and for good performance of transmission and transfer in any position.

##### 4) Brake

[Foot brake]

Check the following when depressing brake pedal while driving;

- that brake works properly,
- that it is free from noise,
- and that braking force applies equally on all wheels.

[Parking brake]

Check to ensure that parking brake is fully effective when the car is stopped on the slop and brake lever is pulled all the way.

##### 5) Steering

Check to ensure that steering wheel is free from instability, or abnormally heavy feeling while driving.

## 6) Engine

- Check that engine responds readily at all speed.
- Check that engine is free from abnormal noise and abnormal vibration.

## 7) Body, Wheels and Power Transmitting System

Check that body, wheels and power transmitting system are free from abnormal noise and abnormal vibration or any other abnormal condition.

## 8) Meters and Gauge

Check that speedometer, odometer, fuel meter, and temperature gauge etc. are operating accurately.

## 9) Oil pressure and charging indicator lights

Make sure that these lights stay off while engine is operating. If either of them comes on during engine operation, it means that something is wrong with engine lubrication system or charging system, and consequently immediate inspection is necessary.

## 10) Seat Belt

Check that seat belt is securely locked.

### **WARNING:**

**For this test, select a safe place without any running car so as to prevent any accident. And again make sure that no man or no other car is seen in front or behind and use great care to the surroundings when carrying out the test.**

## SECTION 2

# TROUBLE SHOOTING

### CONTENTS

2-1. ENGINE .....	2-2
2-2. CARBURETOR .....	2-9
2-3. EXHAUST AND MUFFLER .....	2-9
2-4. CLUTCH .....	2-9
2-5. TRANSMISSION .....	2-10
2-6. DIFFERENTIALS .....	2-11
2-7. PROPELLER SHAFTS .....	2-12
2-8. BRAKES .....	2-12
2-9. SUSPENSION, STEERING SYSTEM AND TIRES .....	2-14
2-10. STARTING MOTOR .....	2-16
2-11. ALTERNATOR .....	2-17
2-12. WIPER MOTOR .....	2-18
2-13. FUEL METER .....	2-18
2-14. SPEEDOMETER .....	2-19
2-15. WATER TEMPERATURE METER .....	2-19

## 2-1. ENGINE

Condition	Possible cause	Correction
<b>Poor starting (Hard starting)</b>	<b>Starter will not run</b>	
	1. Main fuse blown off	Replace
	2. Contact not closing in main switch, or this switch open-circuited	Repair or replace
	3. Run-down battery	Recharge
	4. Defective magnetic switch of starter	Replace
	5. Loose battery terminal connection	Clean and retighten
	6. Defective brushes in starter	Replace
	7. Loose battery cord connection	Retighten
	8. Open in field or armature circuit of starter	Repair or replace
	<b>No sparking</b>	
	1. Defective spark plug	Adjust gap, or replace
	2. High tension cord short-circuited (grounded)	Repair or replace
	3. Cracked rotor or cap in distributor	Replace
	4. Defective signal generator or ignitor	Replace
	5. Maladjusted signal rotor air gap.	Adjust
	6. Contact not closing positively in main switch, or this switch open-circuited	Replace
	7. Loose or blown fuse	Set right or replace
	8. Improper ignition timing	Adjust
	9. Defective ignition coil.	Replace
	<b>Faulty intake and exhaust systems</b>	
	1. Carburetor out of adjustment	Adjust
	2. Fuel pump not discharging adequately	Replace
	3. Clogged fuel filter	Clean, or replace
	4. Defective choke mechanism	Repair or replace
	5. Loose intake manifold	Retighten
	6. Dirty and clogged carburetor	Disassemble and clean
	7. Float level out of adjustment	Adjust
	8. Clogged fuel hose or pipe	Clean or replace
	9. Not enough fuel in the tank	Refill
	10. Malfunctioning fuel cut solenoid valve	Check solenoid valve for proper operation and replace if necessary
<b>Abnormal engine internal condition</b>		
1. Ruptured cylinder head gasket	Replace	
2. Improper valve clearance	Adjust	
3. Weakened or broken valve spring	Replace	
4. Loose manifold, permitting air to be drawn in	Retighten and, as necessary, replace gasket	
5. Worn pistons, rings or cylinders	Replace worn rings and pistons and rebores as necessary	

Condition	Possible cause	Correction
<b>Poor starting (Hard starting)</b>	<ol style="list-style-type: none"> <li>6. Broken valve timing belt</li> <li>7. Poor valve seating</li> <li>8. Wrong kind of engine oil</li> <li>9. Burnt valves</li> <li>10. Sticky valve stem</li> </ol> <p><b>Emission control</b></p> <ol style="list-style-type: none"> <li>1. Malfunctioning PCV valve</li> <li>2. Loose connection or disconnection of vacuum hoses</li> <li>3. ECM is poorly grounded</li> </ol>	<p>Replace Repair or replace Replace Replace Correct or replace valve and guide</p> <p>Replace. Connect securely.</p> <p>Ground ECM securely</p>
<b>Not enough power</b>	<p><b>Inadequate compression</b></p> <ol style="list-style-type: none"> <li>1. Improper valve clearance</li> <li>2. Valves not seating tight</li> <li>3. Valve stems tending to seize</li> <li>4. Broken or weakened valve spring</li> <li>5. Piston rings seized in grooves, or broken</li> <li>6. Worn pistons, rings or cylinders</li> <li>7. Leaky cylinder head gasket</li> </ol> <p><b>Improperly timed ignition</b></p> <ol style="list-style-type: none"> <li>1. Improper ignition timing</li> <li>2. Defective spark plug</li> <li>3. Worn distributor terminals</li> <li>4. Leaks, loose connection or disconnection of high tension cord</li> <li>5. Malfunctioning ignition timing advancers</li> </ol> <p><b>Fuel system out of order</b></p> <ol style="list-style-type: none"> <li>1. Clogged carburetor jets</li> <li>2. Defective fuel pump</li> <li>3. Clogged fuel filter</li> <li>4. Malfunctioning choke system</li> <li>5. Float level out of adjustment</li> <li>6. Clogged fuel pipe</li> <li>7. Clogged fuel tank outlet</li> <li>8. Loose joint in fuel system</li> </ol> <p><b>Abnormal condition in air intake system</b></p> <ol style="list-style-type: none"> <li>1. Air cleaner dirty and clogged</li> <li>2. Poor returning motion of choke valve</li> </ol> <p><b>Overheating tendency of engine</b></p> <ol style="list-style-type: none"> <li>1. (Refer to the section entitled "overheating.")</li> </ol>	<p>Adjust Repair Replace Replace Replace Replace worn parts and rebore as necessary Replace</p> <p>Adjust Adjust gap or replace Dress or replace Connect or replace as necessary Replace</p> <p>Disassemble and clean Repair or replace Replace Adjust or replace Adjust Clean or replace Clean Retighten</p> <p>Clean or replace Repair, adjust or replace</p>

Condition	Possible cause	Correction
<p><b>Not enough power</b></p>	<p><b>Emission control</b></p> <ol style="list-style-type: none"> <li>1. Malfunctioning EGR valve</li> <li>2. Malfunctioning bowl vent solenoid valve.</li> <li>3. Malfunctioning high altitude switch.</li> <li>4. Malfunctioning throttle position switch (wide open switch)</li> </ol> <p><b>Others</b></p> <ol style="list-style-type: none"> <li>1. Dragging brakes</li> <li>2. Slipping clutch</li> </ol>	<p>Check and replace as necessary.  Check and replace as necessary.  Check and replace as necessary  Check nad replace as necessary</p> <p>Repair or replace  Adjust or replace</p>
<p><b>Engine hesitates (Momentary lack of response as the accelerator is depressed. Can occur at all car speeds. Usually most severe when first trying to make the car move, as from a stop sign.)</b></p>	<p><b>Abnormal condition in electrical systems</b></p> <ol style="list-style-type: none"> <li>1. Defective spark plug or plug gap out of adjustment</li> <li>2. Cracked rotor or cap in distributor, resulting in leakage</li> <li>3. Deteriorated ignition coil, or crack resulting in leakage</li> <li>4. Leaky high-tension cords</li> <li>5. Ignition timing out of adjustment</li> </ol> <p><b>Abnormal condition in fuel system</b></p> <ol style="list-style-type: none"> <li>1. Improper adjustment of float level</li> <li>2. Clogged carburetor jets</li> <li>3. Malfunctioning accelerator pump</li> <li>4. Inadequately discharging fuel pump</li> </ol> <p><b>Abnormal condition in engine</b></p> <ol style="list-style-type: none"> <li>1. Loss of compression pressure due to leaky cylinder head gasket</li> <li>2. Compression pressure too low because of worn pistons, rings, cylinders or burnt valves</li> </ol> <p><b>Emission control</b></p> <ol style="list-style-type: none"> <li>1. Malfunctioning bowl vent solenoid valve</li> <li>2. Malfunctioning throttle position switch (wide open switch)</li> <li>3. Malfunctionnig high altitude switch</li> <li>4. Malfunctioning EGR valve</li> <li>5. Malfunctioning thermostatically controlled air cleaner</li> </ol>	<p>Replace or adjust gap</p> <p>Replace</p> <p>Replace</p> <p>Replace  Adjust as prescribed</p> <p>Adjust  Clean  Check and replace as necessary  Replace</p> <p>Replace</p> <p>Replace and rebores as necessary</p> <p>Check and replace as necessary  Check and replace as necessary  Check and replace as necessary  Check and replace as necessary  Check and replace as necessary</p>

Condition	Possible cause	Correction
<p><b>Surges</b> (Engine power variation under steady throttle or cruise. Feels like the car speeds up and down with no change in the accelerator pedal.)</p>	<p><b>Fuel system out of order</b></p> <ol style="list-style-type: none"> <li>1. Clogged fuel filter</li> <li>2. Kinky, leaky or damaged fuel hoses and lines</li> <li>3. Malfunctioning fuel pump</li> <li>4. Leaky manifold and carburetor gaskets</li> <li>5. Improper float level</li> </ol> <p><b>Ignition system out of order</b></p> <ol style="list-style-type: none"> <li>1. Improper ignition timing</li> <li>2. Malfunctioning ignition timing advancers (mechanical and vacuum)</li> <li>3. Leaky or loosely connected high tension cord</li> <li>4. Defective spark plug (excess carbon deposits, improper gap, burned electrodes, etc..)</li> <li>5. Cracked rotor or cap in distributor</li> </ol> <p><b>Emission control</b></p> <ol style="list-style-type: none"> <li>1. Malfunctioning bowl vent solenoid valve</li> <li>2. Malfunctioning throttle position switch (wide open switch)</li> <li>3. Malfunctioning high altitude switch</li> <li>4. Malfunctioning EGR valve</li> <li>5. Malfunctioning thermostatically controlled air cleaner</li> </ol>	<p>Replace Check and replace as necessary Check and replace as necessary Replace Adjust</p> <p>Adjust Check or replace</p> <p>Check and repair or replace Check and clean, adjust or replace Replace</p> <p>Check and replace as necessary Check and replace as necessary Check and replace as necessary Check and replace as necessary Check and replace as necessary.</p>
<p><b>Dieseling</b> (Engine continues to run after ignition switch is turned off. it runs unevenly and may make knocking noise.)</p>	<p>Malfunctioning fuel cut solenoid valve in carburetor</p>	<p>Check solenoid valve for proper operation and replace as necessary</p>
<p><b>Erratic idling</b> (Improper engine idling)</p>	<p><b>Abnormal condition in ignition system</b></p> <ol style="list-style-type: none"> <li>1. Defective spark plug</li> <li>2. Leaky or disconnected high tension cord</li> <li>3. Worn distributor terminals</li> <li>4. Improper ignition timing</li> <li>5. Cracked cap in distributor, leakage inside</li> </ol>	<p>Adjust or replace Connect or replace Replace Adjust Replace</p>

Condition	Possible cause	Correction
<b>Erratic idling</b> (Improper engine idling)	<p><b>Abnormal condition in fuel system</b></p> <ol style="list-style-type: none"> <li>1. Clogged carburetor jets</li> <li>2. Incorrect idle adjustment</li> <li>3. Clogged air cleaner element</li> <li>4. Leaky manifold, carburetor or cylinder head gaskets</li> <li>5. Improper float level</li> <li>6. Malfunctioning choke system</li> <li>7. Malfunctioning fuel cut solenoid valve</li> </ol> <p><b>Others</b></p> <ol style="list-style-type: none"> <li>1. Loose connection or disconnection of vacuum hoses</li> <li>2. Malfunctioning PCV valve</li> <li>3. Low compression</li> <li>4. Loose carburetor and intake manifold bolts and nuts</li> <li>5. Leaky carburetor and intake manifold gaskets</li> </ol>	<p>Clean Adjust Clean or replace Replace</p> <p>Adjust Adjust or replace Replace</p> <p>Connect</p> <p>Check and replace as necessary Previously outlined Tighten bolts and nuts</p> <p>Replace</p>
<b>Abnormal detonation</b>	<p><b>Abnormal condition in ignition system</b></p> <ol style="list-style-type: none"> <li>1. Spark plugs tending to overheat</li> <li>2. Improper ignition timing</li> <li>3. Loose connection in high-tension or low-tension circuit.</li> </ol> <p><b>Abnormal condition in fuel system</b></p> <ol style="list-style-type: none"> <li>1. Clogged fuel filter and fuel lines</li> <li>2. Clogged carburetor jets</li> <li>3. Improper adjustment of float level</li> <li>4. Malfunctioning fuel pump</li> <li>5. Air inhaling from intake manifold and carburetor gaskets</li> </ol> <p><b>Abnormal condition in engine</b></p> <ol style="list-style-type: none"> <li>1. Excessive carbon deposit on piston crowns or cylinder head</li> <li>2. Blown cylinder head gasket, resulting in low compression pressure</li> <li>3. Improper valve clearance</li> <li>4. Valves tending to seize</li> <li>5. Weakened valve springs</li> </ol> <p><b>Others</b></p> <ol style="list-style-type: none"> <li>1. Malfunctioning EGR valve</li> </ol>	<p>Change plug heat value Adjust Retighten</p> <p>Replace or clean Clean Adjust Replace Replace</p> <p>Clean</p> <p>Replace</p> <p>Adjust Replace Replace</p> <p>Replace</p>



Condition	Possible cause	Correction
<p><b>Overheating</b></p>	<p><b>Abnormal condition in ignition system</b></p> <ol style="list-style-type: none"> <li>1. Improper ignition timing</li> <li>2. Wrong heat value of spark plugs</li> </ol> <p><b>Abnormal condition in fuel systems</b></p> <ol style="list-style-type: none"> <li>1. Float level set too low</li> <li>2. Clogged jets in carburetor</li> <li>3. Loose inlet manifold</li> </ol> <p><b>Abnormal condition in cooling system</b></p> <ol style="list-style-type: none"> <li>1. Not enough coolant</li> <li>2. Loose or broken fan belt</li> <li>3. Erratically working thermostat</li> <li>4. Poor water pump performance</li> <li>5. Leaky radiator cores</li> </ol> <p><b>Abnormal condition in lubrication system</b></p> <ol style="list-style-type: none"> <li>1. Clogged oil filter</li> <li>2. Clogged oil strainer</li> <li>3. Deteriorated oil pump performance</li> <li>4. Oil leakage from oil pan or pump</li> <li>5. Improper engine oil grade</li> <li>6. Not enough oil in oil pan</li> </ol> <p><b>Others</b></p> <ol style="list-style-type: none"> <li>1. Dragging brakes</li> <li>2. Slipping clutch</li> <li>3. Blown cylinder head gasket</li> </ol>	<p>Adjust Change heat value</p> <p>Adjust Clean Retighten</p> <p>Refill Adjust or replace Replace Replace Repair or replace</p> <p>Replace Clean Replace Repair Replace with proper grade oil Replenish</p> <p>Repair or replace Adjust or replace Replace</p>
<p><b>Engine noise</b>  <b>Note: Before checking the mechanical noise, make sure that:</b></p> <ul style="list-style-type: none"> <li>• Ignition timing is properly adjusted.</li> <li>• Specified spark plug is used.</li> <li>• Specified fuel is used.</li> </ul>	<p><b>Crankshaft noise</b></p> <ol style="list-style-type: none"> <li>1. Worn-down bearings, resulting in excessively large running clearances</li> <li>2. Worn connecting-rod bearings</li> <li>3. Distorted connecting rods</li> <li>4. Worn crankshaft journals</li> <li>5. Worn crankpins.</li> </ol> <p><b>Noise due to pistons, rings, pins or cylinders</b></p> <ol style="list-style-type: none"> <li>1. Abnormally worn cylinder bores</li> <li>2. Worn pistons, rings or pins</li> <li>3. Pistons tending to seize</li> <li>4. Broken piston rings</li> </ol> <p><b>Others</b></p> <ol style="list-style-type: none"> <li>1. Excessively large camshaft thrust play</li> <li>2. Excessively large crankshaft thrust clearance</li> <li>3. Valve clearance too large</li> <li>4. Not enough engine oil</li> </ol>	<p>Replace</p> <p>Replace Repair or replace Repair by grinding, or replace crankshaft Repair by grinding, or replace crankshaft</p> <p>Rebore to next oversize or replace Replace Replace Replace</p> <p>Replace Adjust as prescribed Adjust as prescribed Replenish</p>

Condition	Possible cause	Correction
<p><b>High fuel consumption</b></p>	<p><b>Abnormal condition ignition system</b></p> <ol style="list-style-type: none"> <li>1. Improper ignition timing</li> <li>2. Leak or loose connection of high tension cord</li> <li>3. Defective spark plug (improper gap, heavy deposits, and burned electrodes, etc..)</li> <li>4. Cracked distributor cap or rotor</li> <li>5. Malfunctioning mechanical and vacuum advancers in distributor</li> </ol> <p><b>Abnormal condition in fuel system</b></p> <ol style="list-style-type: none"> <li>1. Improper float level</li> <li>2. Fuel leakage from tank, pipe or carburetor</li> <li>3. Malfunctioning carburetor choke system</li> <li>4. Dirty or clogged carburetor jets</li> <li>5. Clogged air cleaner element</li> <li>6. Malfunctioning thermostatically controlled air cleaner</li> </ol> <p><b>Abnormal condition in engine</b></p> <ol style="list-style-type: none"> <li>1. Low compression</li> <li>2. Poor valve seating</li> <li>3. Improper valve clearance</li> </ol> <p><b>Emission control</b></p> <ol style="list-style-type: none"> <li>1. Air leaks at exhaust manifold</li> <li>2. Oxygen sensor out of order</li> <li>3. Water temperature switch out of order</li> <li>4. Malfunctioning throttle position switch</li> <li>5. Malfunctioning MCS (mixture control solenoid) valve in carburetor</li> <li>6. Malfunctioning EGR valve</li> </ol> <p><b>Others</b></p> <ol style="list-style-type: none"> <li>1. Dragging brakes</li> <li>2. Slipping clutch</li> <li>3. Improper tire pressure</li> </ol>	<p>Adjust Repair or replace Clean, adjust or replace</p> <p>Replace Check and repair or replace</p> <p>Adjust Repair or replace Repair or replace Clean Clean or replace Check and repair or replace</p> <p>Previously outlined Repair or replace Adjust</p> <p>Tighten manifold bolts and nuts. Replace gasket. Replace. Replace. Replace Replace</p> <p>Replace</p> <p>Repair or replace Adjust or replace Adjust</p>
<p><b>Excessive engine oil consumption</b></p>	<p><b>Oil leakage</b></p> <ol style="list-style-type: none"> <li>1. Loose oil drain plug</li> <li>2. Loose oil pan securing bolts</li> <li>3. Deteriorated or broken oil pan sealant</li> <li>4. Leaky oil seals</li> <li>5. Blown cylinder head gasket</li> <li>6. Improper tightening of oil filter</li> <li>7. Loose oil pressure switch</li> </ol>	<p>Tighten Tighten Replace sealant Replace Replace Tighten Tighten</p>

Condition	Possible cause	Correction
Excessive engine oil consumption	<b>"Oil pumping" (Oil finding its way into combustion chambers.)</b> 1. Sticky piston ring  2. Worn piston ring groove and ring 3. Worn pistons or cylinders	Remove carbon and replace rings Replace piston and ring Replace pistons and rebore as necessary
	<b>Oil leakage along valve stems</b> 1. Defective valve stem oil seals 2. Badly worn valve stem	Replace Replace

## 2-2. CARBURETOR

Condition	Possible cause	Correction
Fuel overflow from carburetor	1. Float valve worn or dirty with foreign matter 2. Float level set too high 3. Float ruptured and containing some fuel 4. Broken or otherwise defective gasket 5. Loose float chamber securing screws	Clean or replace Adjust as prescribed Replace Replace Retighten

## 2-3. EXHAUST AND MUFFLER

Condition	Possible cause	Correction
Poor muffling performance	1. Loose exhaust pipe connection 2. Broken muffler gasket 3. Broken manifold, pipe or muffler 4. Exhaust manifold loose in place 5. Interference between body and muffler	Retighten Replace Repair or replace Retighten Repair, eliminating any contact

## 2-4. CLUTCH

Condition	Possible cause	Correction
Slipping clutch	1. Loss of clearance at the tip of release fork 2. Clutch facings dirty with oil 3. Clutch facings excessively worn 4. Weakened diaphragm spring 5. Distorted pressure plate or flywheel surface 6. Improper clutch pedal free travel	Adjust as prescribed Replace Replace Replace Replace Adjust and, as necessary, replace clutch facings

Condition	Possible cause	Correction
<b>Dragging clutch</b>	<ol style="list-style-type: none"> <li>1. Improper clutch pedal free travel</li> <li>2. Weakened diaphragm spring, or worn spring tip</li> <li>3. Damaged or worn splines of transmission input shaft</li> <li>4. Front input shaft bearing worn or broken</li> <li>5. Excessively wobbly clutch disc</li> <li>6. Clutch facings broken or dirty with oil</li> </ol>	<p>Adjust free travel</p> <p>Replace</p> <p>Replace</p> <p>Replace</p> <p>Replace</p> <p>Replace</p>
<b>Clutch vibration</b>	<ol style="list-style-type: none"> <li>1. Glazed (glass-like) clutch facings</li> <li>2. Clutch facings dirty with oil</li> <li>3. Wobbly clutch disc, or poor facing contact</li> <li>4. Weakened torsion springs (in clutch disc)</li> <li>5. Clutch disc rivets loose</li> <li>6. Distorted pressure plate or flywheel surface</li> <li>7. Weakened engine mounting or loosened mounting bolt or nut</li> </ol>	<p>Repair or replace</p> <p>Replace</p> <p>Replace</p> <p>Replace</p> <p>Replace the disc</p> <p>Replace</p> <p>Retighten or replace</p>
<b>Noisy clutch</b>	<ol style="list-style-type: none"> <li>1. Worn or broken release bearing</li> <li>2. Front input shaft bearing worn down</li> <li>3. Excessive rattle of clutch disc hub</li> <li>4. Cracked clutch disc</li> <li>5. Pressure plate and diaphragm spring rattling</li> </ol>	<p>Replace</p> <p>Replace</p> <p>Replace the disc</p> <p>Replace</p> <p>Replace</p>
<b>Grabbing clutch</b>	<ol style="list-style-type: none"> <li>1. Clutch facings soaked with oil</li> <li>2. Excessively worn clutch facings</li> <li>3. Rivet heads showing out of the facing</li> <li>4. Weakened torsion springs</li> </ol>	<p>Replace</p> <p>Replace</p> <p>Replace</p> <p>Replace</p>

## 2-5. TRANSMISSION

Condition	Possible cause	Correction
<b>Gears slipping out of mesh</b>	<ol style="list-style-type: none"> <li>1. Worn shift fork shaft</li> <li>2. Worn locating steel balls</li> <li>3. Weakened springs for locating steel balls</li> <li>4. Worn shift fork</li> <li>5. Excessive rattle in thrust direction of gears</li> <li>6. Worn ring or hub in synchronizers</li> <li>7. Worn bearings of input shaft, main shaft or countershaft</li> </ol>	<p>Replace</p> <p>Replace</p> <p>Replace</p> <p>Replace</p> <p>Replace</p> <p>Replace</p> <p>Replace</p>
<b>Gears refusing to disengage</b>	<ol style="list-style-type: none"> <li>1. Weakened or broken synchronizer springs</li> <li>2. Worn inner groove of synchronizer ring</li> <li>3. Synchronizer ring seized on the cone</li> <li>4. Distorted shift fork shaft or shift fork</li> </ol>	<p>Replace</p> <p>Replace</p> <p>Replace the ring</p> <p>Replace.</p>

Condition	Possible cause	Correction
<b>Excessive gear noise</b>	<ol style="list-style-type: none"> <li>1. Not enough oil in transmission</li> <li>2. Defective synchronizer</li> <li>3. Gears rattling in thrust direction</li> <li>4. Broken or worn bearings</li> <li>5. Damaged or worn gears</li> </ol>	Replenish Replace Replace Replace Replace
<b>Hard shifting</b>	<ol style="list-style-type: none"> <li>1. Clutch pedal play too large, resulting in a "dragging clutch"</li> <li>2. Worn clutch disc facings</li> <li>3. Clutch disc facings dirty with oil.</li> <li>4. Distorted or unevenly worn shift fork shaft</li> <li>5. Broken locating balls</li> <li>6. Worn synchronizer sleeve or ring</li> <li>7. Worn synchronizer hub</li> </ol>	Adjust as prescribed  Replace. Replace. Replace Replace Replace Replace

## 2-6. DIFFERENTIALS

Condition	Possible cause	Correction
<b>Gear noise</b>	<ol style="list-style-type: none"> <li>1. Maladjusted backlash between drive pinion and ring gear</li> <li>2. Damaged gear teeth or improper mesh of drive pinion and ring gear</li> <li>3. Improper tooth contact in the mesh between drive pinion and ring gear</li> <li>4. Insufficient or wrong kind of gear oil</li> <li>5. Ring gear wobbling when turning, or ring gear securing bolts loose</li> <li>6. Broken or otherwise damaged teeth of side gears or differential pinion gears</li> </ol>	Adjust as prescribed  Replace or adjust  Adjust as prescribed  Replenish or replace Replace, or retighten  Replace
<b>Bearing noise</b>	<ol style="list-style-type: none"> <li>1. (Constant noise) Insufficient or wrong kind of gear oil</li> <li>2. (Constant noise) Damaged or worn bearings or borne parts</li> <li>3. (Noise during coasting) Damaged bearings of rear drive pinion</li> <li>4. (Noise during turning) Broken bearings on axle shafts</li> </ol>	Replenish or change  Replace.  Replace  Replace

## 2-7. PROPELLER SHAFTS

Condition	Possible cause	Correction
Vibration and noise	<ol style="list-style-type: none"> <li>1. Broken or worn bearings of universal joint spider</li> <li>2. Distorted propeller shaft</li> <li>3. Unbalanced propeller shaft</li> <li>4. Loose propeller shaft</li> </ol>	<p>Replace</p> <p>Replace</p> <p>Replace</p> <p>Retighten</p>
Noise occurring at standing start or during coasting	<ol style="list-style-type: none"> <li>1. Worn or damaged universal joint</li> <li>2. Worn propeller shaft splines, due to lack of lubrication</li> <li>3. Loose propeller shaft</li> <li>4. Loose flanged yoke of universal joint</li> </ol>	<p>Replace</p> <p>Replace</p> <p>Retighten</p> <p>Retighten</p>

## 2-8. BRAKES

Condition	Possible cause	Correction
Not enough braking force	<ol style="list-style-type: none"> <li>1. Brake oil leakage from brake lines</li> <li>2. Brake disc or pads stained with oil</li> <li>3. Overheated brakes</li> <li>4. Poor contact of shoes on brake drum</li> <li>5. Brake shoes linings stained with oil or wet with water</li> <li>6. Badly worn brake shoe linings</li> <li>7. Defective wheel cylinders</li> <li>8. Malfunctioning caliper assembly</li> </ol>	<p>Locate leak point and repair</p> <p>Clean or replace</p> <p>Determine cause and repair</p> <p>Repair for proper contact</p> <p>Replace</p> <p>Replace</p> <p>Repair or replace</p> <p>Repair or replace</p>
Brake Pull (Brakes not working in unison)	<ol style="list-style-type: none"> <li>1. Shoe linings wet with water or stained with oil in some brakes</li> <li>2. Drum-to-shoe clearance out of adjustment in some brakes (Malfunctioning auto adjusting mechanism)</li> <li>3. Drum out of round in some brakes</li> <li>4. Wheel tires inflated unequally</li> <li>5. Malfunctioning wheel cylinders</li> <li>6. Disturbed front end alignment</li> <li>7. Unmatched tires on same axle</li> <li>8. Restricted brake tubes or hoses</li> <li>9. Malfunctioning caliper assembly</li> <li>10. Loose suspension parts</li> <li>11. Loose calipers</li> </ol>	<p>Replace</p> <p>Check for inoperative auto adjusting mechanism</p> <p>Replace</p> <p>Inflate equally</p> <p>Repair or replace</p> <p>Adjust as prescribed</p> <p>Use tires with approximately the same amount of tread on the same axle</p> <p>Check for soft hoses and damaged lines. Replace with new hoses and new double-walled steel brake tubing.</p> <p>Check for stuck or sluggish pistons and proper lubrication of caliper slide bush. Caliper should slide.</p> <p>Check all suspension mountings</p> <p>Check and torque bolts to specifications</p>

Condition	Possible cause	Correction
<b>Excessive pedal travel (Pedal stroke too large)</b>	<ol style="list-style-type: none"> <li>1. Partial brake system failure</li> <li>2. Insufficient fluid in master cylinder reservoirs</li> <li>3. Air in system (Pedal soft/spongy)</li> <li>4. Rear brake system not adjusted (malfunctioning auto adjusting mechanism)</li> <li>5. Bent brake shoes</li> <li>6. Worn rear brake shoes</li> </ol>	<p>Check diagonal brake systems and repair as necessary</p> <p>Fill reservoirs with approved brake fluid. Check for leaks and air in brake systems. Check warning light. Bleed system if necessary.</p> <p>Bleed system</p> <p>Adjust rear brakes (Repair auto adjusting mechanism)</p> <p>Replace brake shoes</p> <p>Replace brake shoes</p>
<b>Dragging brakes (A very light drag is present in all disc brakes immediately after pedal is released)</b>	<ol style="list-style-type: none"> <li>1. Master cylinder pistons not returning correctly</li> <li>2. Clogged return port in master cylinder</li> <li>3. Restricted brake tubes or hoses</li> <li>4. Incorrect parking brake adjustment</li> <li>5. Weakened or broken return springs in the brake</li> <li>6. Sluggish parking-brake cables or linkage</li> <li>7. Wheel cylinder or caliper piston sticking</li> </ol>	<p>Repair master cylinder</p> <p>Clean</p> <p>Check for soft hoses or damaged tubes and replace with new hoses and/or new double-walled steel brake tubing</p> <p>Check and adjust to correct specifications</p> <p>Replace</p> <p>Repair or replace</p> <p>Repair as necessary</p>
<b>Pedal pulsation (Pedal pulsates when depressed for braking)</b>	<ol style="list-style-type: none"> <li>1. Damaged or loose wheel bearings</li> <li>2. Excessive disc lateral runout</li> <li>3. Parallelism not within specifications</li> <li>4. Rear drums out of round</li> </ol>	<p>Replace wheel bearings</p> <p>Check per instructions. If not within specifications, replace or machine the disc.</p> <p>Check per instructions. If not within specifications, replace or machine the disc.</p> <p>Check runout.</p>
<b>Braking noise</b>	<ol style="list-style-type: none"> <li>1. Glazed shoe linings, or foreign matters stuck to linings</li> <li>2. Worn or distorted shoe linings</li> <li>3. Loose front wheel bearings</li> <li>4. Distorted backing plates or loose mounting bolts</li> </ol>	<p>Repair or replace shoe lining</p> <p>Replace shoe lining (or pad)</p> <p>Replace wheel bearings</p> <p>Replace or retighten securing bolts</p>

## 2-9. SUSPENSION, STEERING SYSTEM AND TIRES

Condition	Possible cause	Correction
<b>Hard steering</b>	<ol style="list-style-type: none"> <li>1. Wheel tires not adequately inflated</li> <li>2. Bind in tie rod end ball stud</li> <li>3. Linkage connections tending to seize</li> <li>4. Steering gearbox out of adjustment</li> <li>5. Unevenly worn steering shaft bush</li> <li>6. Disturbed front wheel alignment</li> </ol>	<p>Adjust the pressure                      Replace                      Repair or replace                      Adjust as prescribed                      Replace                      Adjust as prescribed</p>
<b>Wobbly steering wheel (Shimmy, shake or vibration)</b>	<ol style="list-style-type: none"> <li>1. Wheel tires inflated unequally</li> <li>2. Wobbly wheels</li> <li>3. Large difference in tire diameter between right and left wheels</li> <li>4. Loose hub nuts</li> <li>5. Damaged or worn wheel bearings</li> <li>6. Worn or loose tie rod ends</li> <li>7. Steering gearbox out of adjustment</li> <li>8. Steering gearbox mounted loose</li> <li>9. Worn steering knuckle oil seal</li> <li>10. Tire or wheel out of balance</li> <li>11. Blister or bump on tire</li> <li>12. Disturbed front wheel alignment</li> </ol>	<p>Adjust tire pressure                      Repair or replace                      Replace</p> <p>Retighten                      Replace                      Replace or retighten                      Adjust as prescribed                      Retighten                      Replace                      Balance wheel or replace tire and/or wheel                      Replace tire                      Check front wheel alignment</p>
<b>Steering wheel pulling to one side (car pulls)</b>	<ol style="list-style-type: none"> <li>1. Unevenly worn wheel tires</li> <li>2. Brake dragging in one road wheel</li> <li>3. Wheel tires unequally inflated</li> <li>4. Worn or distorted link rods</li> <li>5. Disturbed front wheel alignment</li> <li>6. Loose, bent or broken front or rear suspension parts</li> </ol>	<p>Replace                      Repair                      Adjust tire pressure                      Replace                      Adjust as prescribed                      Tighten or replace suspension parts</p>
<b>Shocks coming to steering wheel (or wheel tramp)</b>	<ol style="list-style-type: none"> <li>1. Tire inflating pressure too high</li> <li>2. Poor shock absorber performance</li> <li>3. Differences in tire diameter among four road wheels</li> <li>4. Worn steering linkage connections</li> <li>5. Worn or broken front wheel bearings</li> <li>6. Loose front wheel</li> <li>7. Steering wheel loose in place</li> <li>8. Blister or bump on tire</li> </ol>	<p>Reduce to the specification                      Replace                      Adjust</p> <p>Replace                      Replace                      Retighten                      Retighten the nut                      Replace tire</p>
<b>Rapid wear or uneven wear of wheel tires (Abnormal or excessive tire wear)</b>	<ol style="list-style-type: none"> <li>1. Wheel tires improperly inflated</li> <li>2. Differences in diameter among four tires</li> <li>3. Worn or loose road wheel bearings</li> <li>4. Wobbly wheel tires</li> </ol>	<p>Adjust tire pressure                      Adjust or replace                      Replace                      Repair or replace</p>



Condition	Possible cause	Correction
<b>Rapid wear or uneven wear of wheel tires (Abnormal or excessive tire wear)</b>	<ol style="list-style-type: none"> <li>5. Wheel tires improperly "rotated" to result in unbalance</li> <li>6. Disturbed front wheel alignment</li> <li>7. Hard driving</li> </ol>	<p>Adjust</p> <p>Adjust as prescribed</p> <p>Replace tire</p>
<b>Steering noise</b>	<ol style="list-style-type: none"> <li>1. Loose bolts and nuts</li> <li>2. Loose leaf spring seats</li> <li>3. Broken or otherwise damaged wheel bearings</li> <li>4. Worn or sticky tie rod ends</li> <li>5. Linkage joints needing grease</li> </ol>	<p>Retighten</p> <p>Retighten</p> <p>Replace</p> <p>Replace</p> <p>Lubricate or replace</p>
<b>Too much play in steering</b>	<ol style="list-style-type: none"> <li>1. Worn wheel bearings</li> <li>2. Steering gear box attachments loose</li> <li>3. Steering gear box adjustments</li> <li>4. Worn steering shaft joints</li> <li>5. Worn tie rod ends or drug rod ball joints</li> </ol>	<p>Replace wheel bearing</p> <p>Tighten or repair</p> <p>Check and adjust</p> <p>Replace joint</p> <p>Replace tie rod end or tie rod</p>
<b>Poor returnability</b>	<ol style="list-style-type: none"> <li>1. Bind in tie rod end ball studs</li> <li>2. Bind in steering column</li> <li>3. Lack of lubricant steering gear box</li> <li>4. Disturbed front end alignment</li> <li>5. Steering gear box adjustment</li> <li>6. Tires not adequately inflated</li> </ol>	<p>Replace tie rod end</p> <p>Repair or replace</p> <p>Check, lubricate or replace</p> <p>Check and adjust front end alignment</p> <p>Check and adjust gear box torque</p> <p>Adjust pressure</p>
<b>Abnormal noise, front end</b>	<ol style="list-style-type: none"> <li>1. Worn, sticky or loose tie rod ends, drug rod ball joints or axle shaft joints</li> <li>2. Damaged shock absorbers or mountings</li> <li>3. Loose stabilizer bar</li> <li>4. Loose wheel nuts</li> <li>5. Loose suspension bolts or nuts</li> <li>6. Broken or otherwise damaged wheel bearings</li> <li>7. Broken suspension springs</li> </ol>	<p>Replace tie rod ends, drug rod or axle shaft joints</p> <p>Replace or repair</p> <p>Tighten bolts or replace bushes</p> <p>Tighten</p> <p>Tighten suspension bolts or nuts</p> <p>Replace</p> <p>Replace</p>
<b>Wander or poor steering stability</b>	<ol style="list-style-type: none"> <li>1. Mismatched or uneven tires</li> <li>2. Loose tie rod ends or drug rod</li> <li>3. Faulty shock absorber or mounting</li> </ol>	<p>Replace tire or inflate tires to proper pressure</p> <p>Replace tie rod end or drug rod</p> <p>Replace absorber or repair mounting</p>

Condition	Possible cause	Correction
Wander or poor steering stability	<ol style="list-style-type: none"> <li>4. Loose stabilizer bar</li> <li>5. Broken or sagging springs</li> <li>6. Steering gear box adjustment</li> <li>7. Front wheel alignment</li> </ol>	Tighten or replace stabilizer bar or bushes Replace spring Check or adjust steering gear box torque Check front wheel alignment
Low or uneven trim height	<ol style="list-style-type: none"> <li>1. Broken or sagging springs</li> <li>2. Overloaded</li> <li>3. Incorrect springs</li> </ol>	Replace Check loading Replace
Ride too soft	<ol style="list-style-type: none"> <li>1. Faulty shock absorbers</li> </ol>	Replace
Suspension bottoms	<ol style="list-style-type: none"> <li>1. Overloaded</li> <li>2. Faulty shock absorbers</li> <li>3. Incorrect, broken or sagging springs</li> </ol>	Checking loading. Replace Replace
Body leans or sways in corners	<ol style="list-style-type: none"> <li>1. Loose stabilizer bar</li> <li>2. Faulty shock absorbers or mounting</li> <li>3. Broken or sagging springs</li> <li>4. Overloaded</li> </ol>	Tighten stabilizer bar bolts or replace bushes Replace shock absorbers or tighten mounting Replace Check loading

## 2-10. STARTING MOTOR

Condition	Possible cause	Correction
Starter runs but pinion will not mesh into ring gear.	<ol style="list-style-type: none"> <li>1. Worn pinion of starter clutch.</li> <li>2. Defective splines, resulting in sticky pinion plunging motion.</li> <li>3. Worn bush.</li> <li>4. Wrong pinion plunging position.</li> <li>5. Worn teeth of ring gear.</li> </ol>	Replace. Repair or replace.  Replace. Adjust Replace.
Starter will not run at all, or runs but runs too slow to crank with full force.	<b>Battery trouble</b> <ol style="list-style-type: none"> <li>1. Poor contact in battery terminal connection</li> <li>2. Loose ground cable connection</li> <li>3. Battery run down</li> <li>4. Battery voltage too low due to battery deterioration</li> </ol> <b>Ignition switch trouble</b> <ol style="list-style-type: none"> <li>1. Poor contacting action</li> <li>2. Lead wire socket loose in place</li> <li>3. Opne-circuit between ignition switch and magnet switch</li> </ol>	Repair or retighten  Retighten Recharge Replace  Replace Retighten Repair

Condition	Possible cause	Correction
Starter will not run at all, or runs but runs too slow to crank with full force	<b>Magnet switch trouble</b> 1. Lead wire socket loose in place 2. Burnt contact plate, or poor contacting action 3. Open-circuit in pull-in coil 4. Open-circuit in holding coil	Retighten Replace, or repair  Replace Replace
	<b>Starter proper trouble</b> 1. Brushes seating poorly or worn down 2. Burnt commutator 3. Open-circuit in armature winding 4. Worn-down starter	Repair or replace Repair or replace Replace Replace
Starter does not stop running.	1. Fused contact points of magnet-switch contact plate 2. Short-circuit between turns of magnet-switch coil (layer short-circuit) 3. Failure of returning action in ignition switch	Repair or replace  Replace  Replace

## 2-11. ALTERNATOR

Condition	Possible cause	Correction
Battery quickly becomes over-discharged.	1. Loose or broken "V" belt 2. Battery cables loose, corroded or worn 3. Low level of battery electrolyte 4. Defective battery cell plates 5. Insufficient contact in battery terminal connection. 6. Excessive electrical load 7. IC regulator or alternator faulty 8. Defective idle up system	Adjust or replace Repair or replcae Replace Replace the battery Clean and retighten  Check charging system Replace Repair or replace
Charge light does not light with ignition ON and engine off	1. Fuse blown 2. Light burned out 3. Loose wiring connection 4. IC regulator faulty	Check fuse Replace light Tighten loose connections Replace
Alternator noise	1. Worn, loose or otherwise defective bearings	Replace

## 2-12. WIPER MOTOR

Condition	Possible cause	Correction
Wiper will not run	<ol style="list-style-type: none"> <li>1. Fuse set loose or blown off</li> <li>2. Incomplete metal-to-metal contact in connector</li> <li>3. Worn or floating brushes</li> <li>4. Dirty or burnt commutator</li> <li>5. Short-circuited or fused field coil</li> <li>6. Loose terminal connection on wiper switch</li> </ol>	Tighten or replace Repair  Replace or repair Repair or replace Replace Repair
Wiper will not stop running	<ol style="list-style-type: none"> <li>1. Defective wiper switch</li> </ol>	Repair or replace
Wiper stops at wrong position	<ol style="list-style-type: none"> <li>1. Improper wiper arm setting</li> <li>2. Cover plate incorrectly positioned in place</li> </ol>	Repair Repair
Poor wiping action	<ol style="list-style-type: none"> <li>1. Insufficient pressure of wiper arm</li> <li>2. Deteriorated or hardened blade</li> <li>3. Blade improperly set</li> <li>4. Windshield dirty with oil</li> </ol>	Replace Replace Repair or replace Clean

## 2-13. FUEL METER

Condition	Possible cause	Correction
Faulty meter indication	<ol style="list-style-type: none"> <li>1. Incomplete metal-to-metal contact in terminal connections</li> <li>2. Defective receiver gauge due to burnt point or deformed bimetal element</li> <li>3. Erratic float movement</li> <li>4. Defective grounding (for float and gauge)</li> </ol>	Retighten  Replace  Repair or replace Repair
No indication	<ol style="list-style-type: none"> <li>1. Open-circuit</li> <li>2. Open-circuited heat wire</li> <li>3. Burnt point</li> <li>4. Deformed bimetal element</li> <li>5. Open-circuited resistor</li> </ol>	Repair Replace Replace Replace Replace

## 2-14. SPEEDOMETER

Condition	Possible cause	Correction
Faulty indication	<ol style="list-style-type: none"><li>1. Damaged speedometer drive or driven gear</li><li>2. Defective drive cable</li><li>3. Drive cable incompletely or improperly tied into the meter</li><li>4. Defective speedometer</li></ol>	Replace Replace Set right  Replace
Speedometer noise	<ol style="list-style-type: none"><li>1. Inadequately lubricated or defective cable</li><li>2. Not enough oil in transfer</li></ol>	Lubricate or replace Replenish

## 2-15. WATER TEMPERATURE METER

Condition	Possible cause	Correction
Faulty indication	<ol style="list-style-type: none"><li>1. Incomplete metal-to-metal contact in terminal connections</li><li>2. Receiver gauge defective (due to burnt point or deformed bimetal element)</li><li>3. Defective temperature gauge</li></ol>	Repair and tighten  Replace  Replace
No indication	<ol style="list-style-type: none"><li>1. Open-circuit</li><li>2. Defective receiver gauge (open-circuited heat wire, deformed bimetal element or pointer)</li><li>3. Defective temperature gauge</li></ol>	Repair Replace  Replace



## SECTION 3

# ENGINE

### CONTENTS

3-1.	GENERAL DESCRIPTION .....	3-2
3-2.	ENGINE SERVICES NOT REQUIRING ENGINE REMOVAL .....	3-5
3-3.	ENGINE REMOVAL .....	3-6
3-4.	ENGINE DISASSEMBLY .....	3-9
3-5.	INSPECTION OF ENGINE COMPONENTS .....	3-17
3-6.	ENGINE REASSEMBLY .....	3-35
3-7.	ENGINE INSTALLATION .....	3-53
3-8.	ENGINE MAINTENANCE SERVICE .....	3-53
3-9.	RECOMMENDED TORQUE SPECIFICATIONS .....	3-58

### 3-1. GENERAL DESCRIPTION

#### 1) Engine

The engine is water-cooled, in line 4 cylinders, 4 stroke cycle gasoline unit with its S.O.H.C. (Single overhead camshaft) valve mechanism arranged for "V"-type valve configuration. This single overhead camshaft is mounted over the cylinder head; it is driven from crankshaft through timing belt, and no push rods are provided in the valve train system.

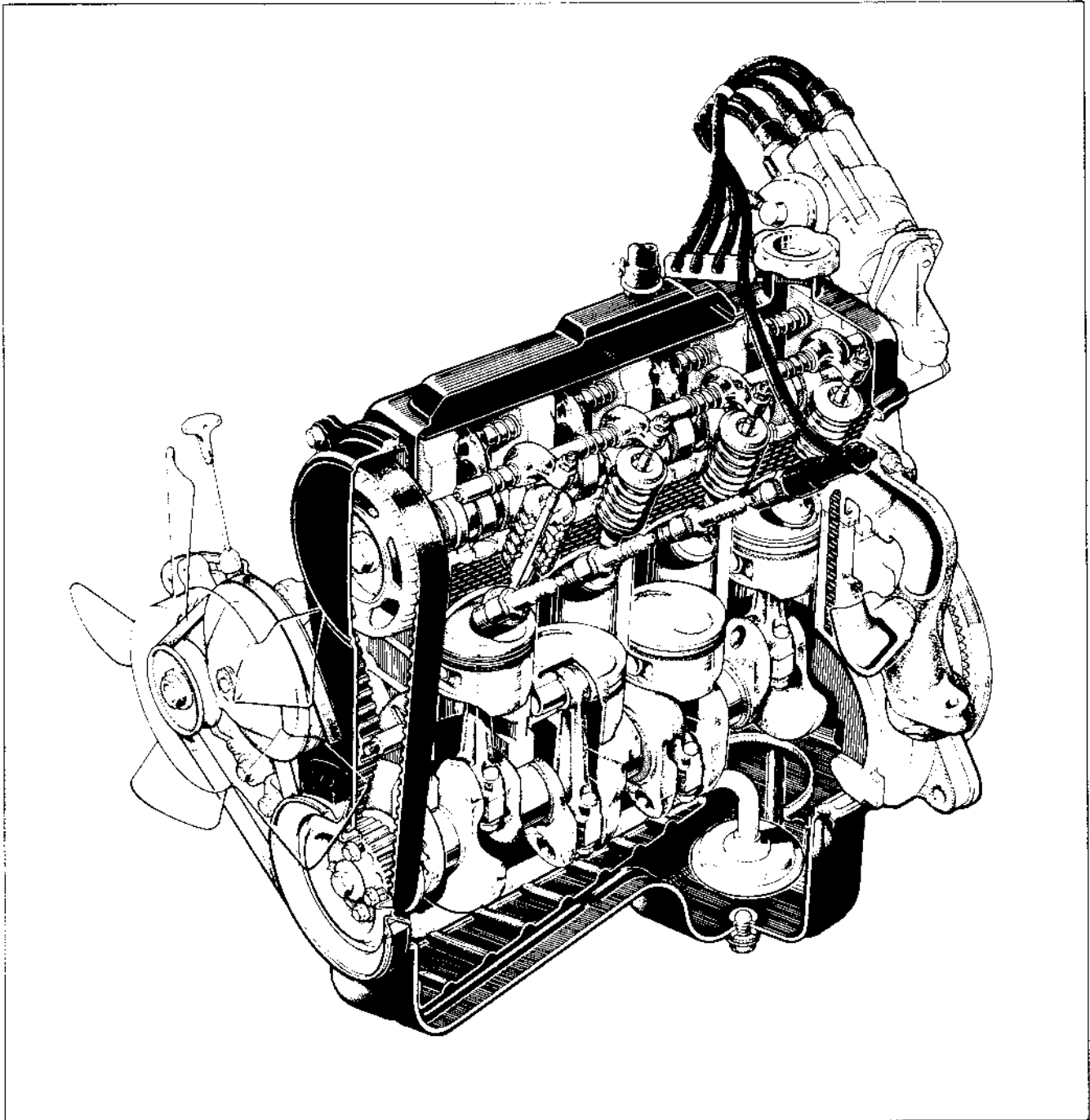


Fig. 3-1-1



## 2) Engine Lubrication

The oil pump is of a trochoid type, and mounted on the crankshaft at the crankshaft pulley side.

Oil is drawn up through the oil pump strainer and passed through the pump to the oil filter.

The filtered oil flows into two paths in cylinder block.

In one path, oil reaches the crankshaft journal bearings.

Oil from the crankshaft journal bearings is supplied to the connecting rod bearings by means of intersecting passages drilled in the crankshaft, and then injected from a small hole provided on the big end of connecting rod to lubricate piston, rings, and cylinder wall.

In another path, oil goes up to the cylinder head and lubricates rocker arms, valves and camshaft, etc., after passing through the internal oilway of rocker arm shafts.

An oil relief valve is provided on the oil pump. This valve starts relieving oil pressure when the pressure comes over about  $3.0 \text{ kg/cm}^2$  (42.7 psi, 300 kPa). Relieved oil drains back to the oil pan.

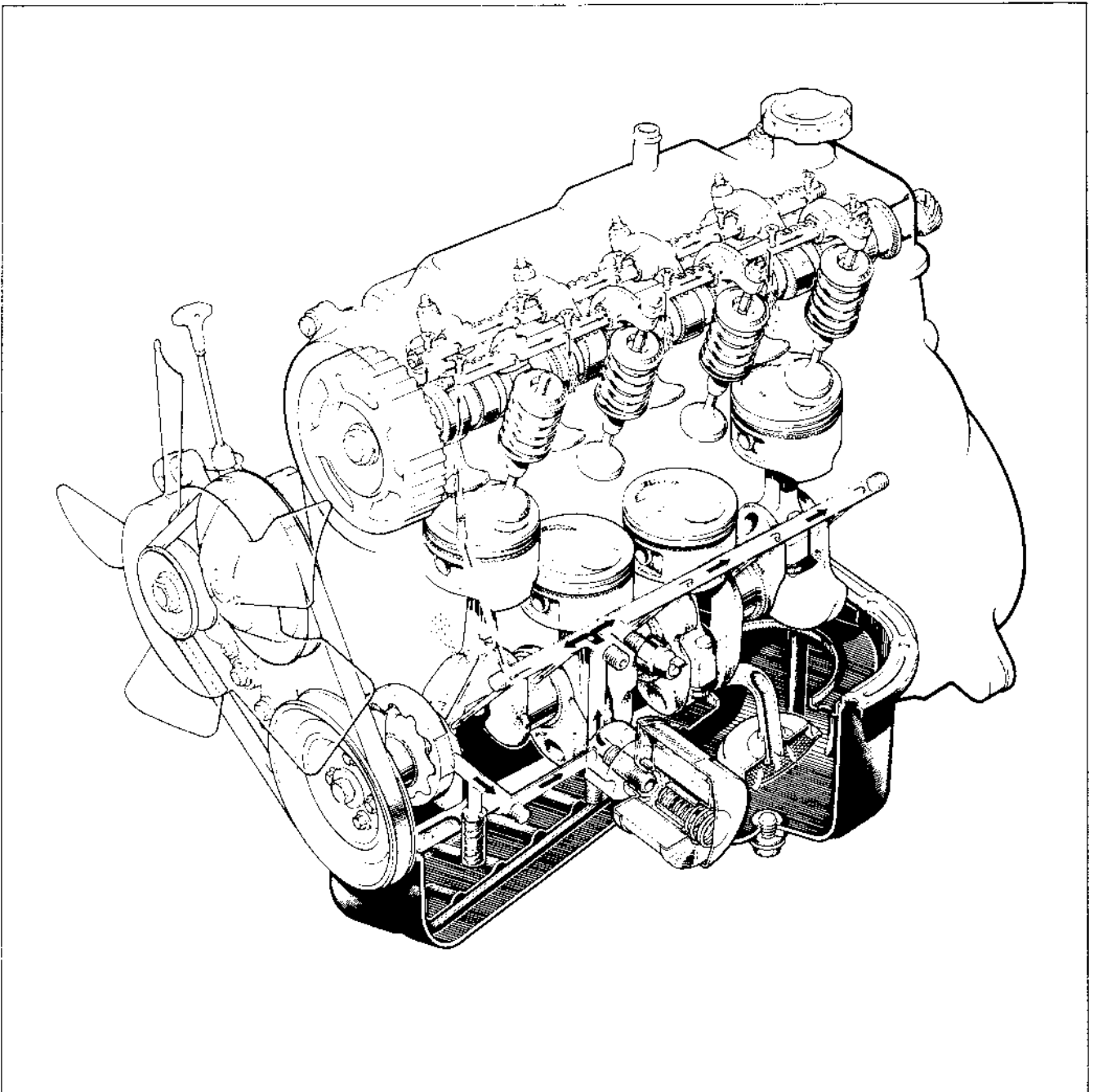


Fig. 3-1-2

### 3) Cylinder Head and Valve Train

The cylinder head is made of cast aluminum alloy and has four combustion chambers arranged in-line. Each combustion chamber has an intake and an exhaust ports.

Moreover, as shown in Figure 3-1-3, the air induction nozzle is provided near each intake valve. During intake stroke of the engine, air/fuel mixture enters into the combustion chamber from carburetor through intake manifold and intake valve. At the same time, air flows to the air induction nozzle through carburetor and air induction passage in the intake manifold, and jets into the combustion chamber.

The air jetted into the combustion chamber accelerates the mixture swirl to improve the combustion efficiency.

A single overhead camshaft driven by the crankshaft through the timing belt is mounted on the cylinder head. The camshaft has eight cams, and each cam operates the intake or exhaust valve through rocker arm. The valve lash can be adjusted by turning the adjusting screw on the rocker arm after loosening the lock nut.

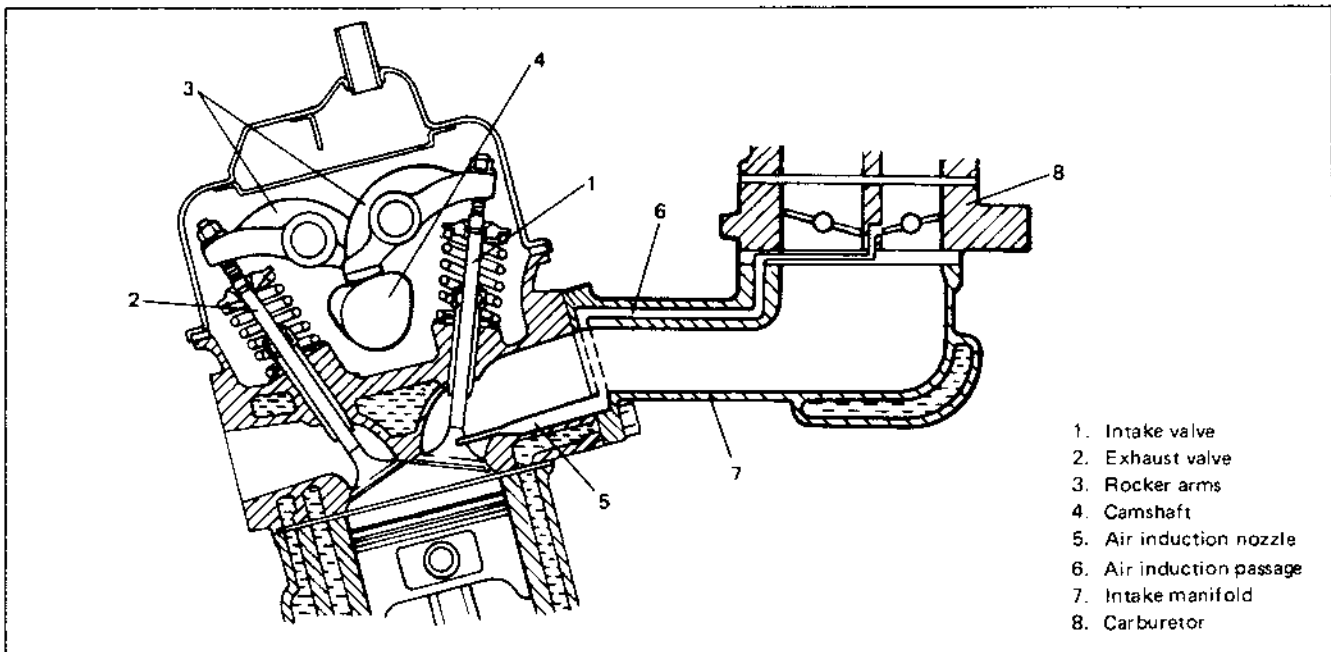


Fig. 3-1-3 Cylinder head and valve train

### 4) Cylinder Block

The cylinder block is made of cast aluminum alloy and has 4 cylinders arranged "In-Line". A cylindrical cast iron sleeve is installed in each cylinder.

### 5) Crankshaft and Main Bearings

A monoblock casting crankshaft is supported by 5 main bearings which are of precision insert type. Four crank pins on the crankshaft are positioned 180° apart.

### 6) Pistons, Rings, Piston Pins and Connecting Rods

The piston is cast aluminum alloy, and has two compression rings and one oil ring.

Among two compression rings (top and 2nd rings), the top ring is plated with hard chromium for improvement in abrasion resistance.

The oil ring consists of two rails and one spacer.

The piston pin is offset 0.5 mm towards the major thrust side. This allows a gradual change in thrust pressure against the cylinder wall as the piston travels its path. Pins are chromium steel and have a floating fit in the pistons. They are retained in the connecting rods by a press fit. The connecting rods are made of forged steel, and the rod bearings are of precision insert type.

### 3-2. ENGINE SERVICES NOT REQUIRING ENGINE REMOVAL

The following parts of components do not require engine removal to receive services (replacement, inspection or adjustment):

Part or Component	Nature of Service
1. Spark plug	Replacement or inspection
2. Distributor	Replacement, inspection or adjustment
3. Exhaust manifold	Replacement or inspection
4. Oil filter	Replacement
5. Oil pressure unit	Replacement
6. Cylinder head cover	Replacement
7. Rocker shaft	Replacement or inspection
8. Rocker-arm	Replacement or inspection
9. Rocker-arm spring	Replacement or inspection
10. Cam shaft	Replacement or inspection (Cylinder head removal required)
11. Cylinder head	Replacement or inspection
12. Radiator	Replacement or inspection (Cooling fan and fan shroud removal required)
13. Cooling fan	Replacement
14. Camshaft timing belt pulley	Replacement or inspection
15. Crankshaft timing belt pulley	Replacement or inspection
16. Timing belt	Replacement or inspection (Cooling fan and fan shroud removal required)
17. Fuel pump	Replacement
18. Carburetor	Replacement, inspection or adjustment
19. Intake manifold	Replacement
20. Alternator	Replacement or inspection
21. Starter motor	Replacement or inspection
22. Fan belt	Replacement, inspection or tension adjustment
23. Water pump	Replacement (Cooling fan and fan shroud removal required)
24. Pulleys (crank, generator, fan)	Replacement
25. Timing belt cover	Replacement (Cooling fan and fan shroud removal required)
26. Water hose	Replacement or inspection
27. Oil pan, oil strainer, and oil pump	Replacement or inspection
28. Piston and connecting rod	Replacement or inspection (Cylinder head and oil pan removal required)

### 3-3. ENGINE REMOVAL

- 1) Disconnect negative (—) and positive (+) cords from battery terminals.
- 2) From starter motor terminals, disconnect black/yellow lead wire and positive (+) battery cord.
- 3) Disconnect coupler and white lead wire from alternator terminals.
- 4) Disconnect lead wires from water temperature gauge and thermal switch. The gauge and switch are on intake manifold. Disconnect earth lead wire from intake manifold.
- 5) Disconnect couplers of carburetor fuel cut solenoid valve, vent solenoid valve and mixture control solenoid valve, and disconnect couplers from TWSVS and VSV.
- 6) Remove warm air hose.
- 7) Disconnect breather hose from air cleaner case.
- 8) Remove air intake case from carburetor body and air inlet hose.
- 9) Disconnect accelerator cable from carburetor.
- 10) Disconnect vacuum hoses of TCAC and canister from intake manifold.
- 11) Remove fuel tank filler cap to release fuel vapor pressure in fuel tank. After releasing, reinstall it. Disconnect fuel feed and return hoses from fuel pump.
- 12) Disconnect lead wire from oil pressure unit terminal and oxygen sensor lead wire at the coupler.
- 13) Disconnect lead wires of back-up light switch and fifth switch at their couplers.
- 14) Disconnect distributor lead wire at the coupler.
- 15) Pull off high-tension cord from ignition coil.
- 16) Loosen radiator drain plug to drain cooling water.
- 17) Disconnect water hoses from thermostat cap and water inlet pipe. After removing cooling fan & clutch and fan shroud, remove radiator.

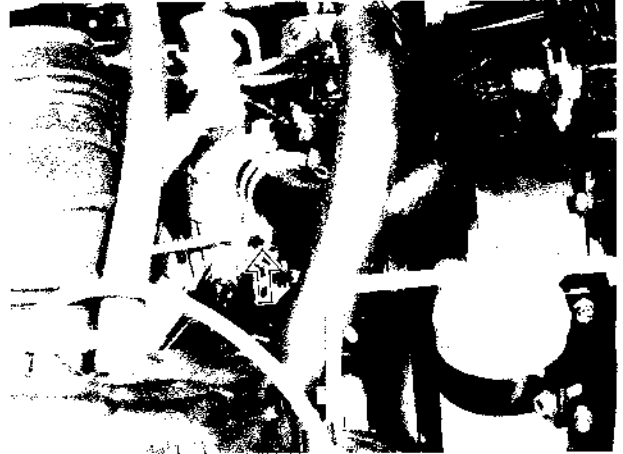


Fig. 3-3-1

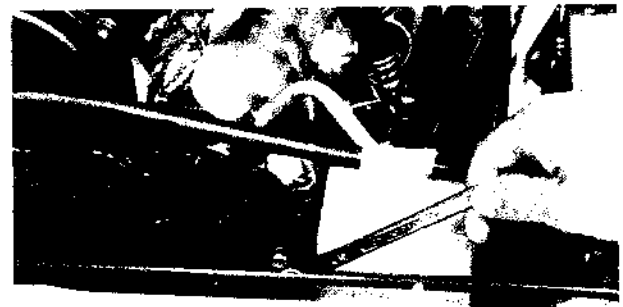


Fig. 3-3-2

- 18) Disconnect heater hoses from heater unit outlet pipe and intake manifold.



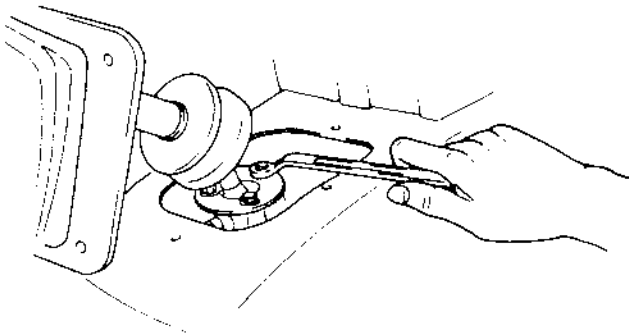
Fig. 3-3-3

- 19) Disconnect brake booster vacuum hose from pipe.
- 20) Disconnect coupler of lead wire (black) from distributor gear case.
- 21) Remove 4 bolts fastening gear shift lever boot No. 2 and move the boot upward.



*Fig. 3-3-4*

- 22) Move gear shift lever boot No. 1 to upper side of shift lever.
- 23) Loosen 3 bolts tightening gear shift lever case cover and take shift lever out of lever case.



*Fig. 3-3-5*

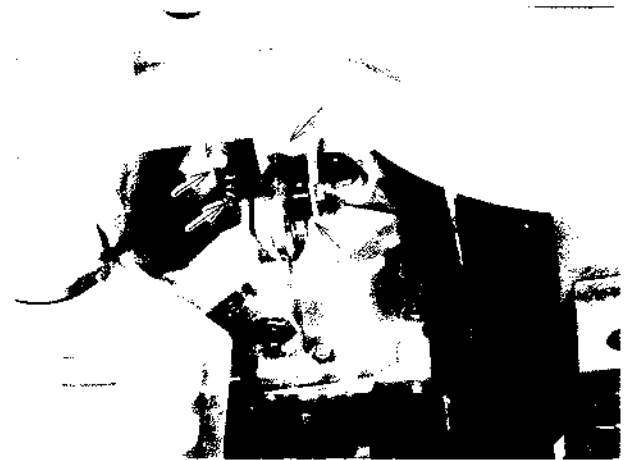
- 24) Raise vehicle.
- 25) Sever exhaust manifold from muffler by undoing joint.

- 26) Disconnect clutch cable from engine mounting bracket and clutch release lever.
- 27) Loosen drain plug to drain transmission oil.
- 28) Remove propeller shaft interconnecting transmission case and transfer case.
- 29) By using a chain block, hold engine so that the engine is kept from falling.

**NOTICE:**

To use a chain block for hoist, take hitch on engine at two hooks provided, one on inlet-manifold side and the other on exhaust-manifold side.

- 30) Remove exhaust center pipe mounting bracket and 4 transmission mounting bolts.



*Fig. 3-3-6*

- 31) Remove the pipe connected to chassis under the transmission case.



*Fig. 3-3-7*

32) Lower vehicle and remove 4 bolts securing right and left engine mounting brackets (body side).

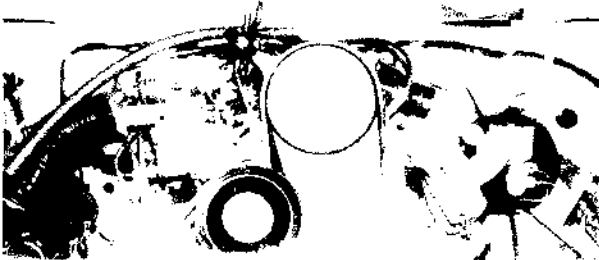


*Fig. 3-3-8*

**CAUTION:**

Before lifting engine and transmission, recheck to ascertain all hoses, electric wires and cables are disconnected from engine and transmission.

33) Take down engine by operating a hoisting means.



*Fig. 3-3-9*

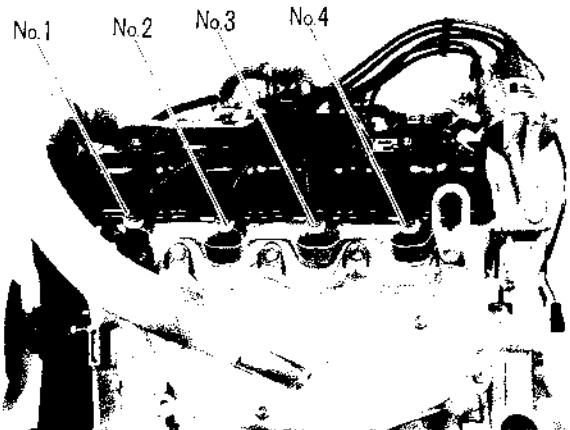


*Fig. 3-3-10*

34) Remove clutch lower plate.

35) Separate transmission from engine.

Throughout this MANUAL, 4 cylinders of engine are identified by numbers: No. 1, No. 2, No. 3 and No. 4 as counted from front end.



*Fig. 3-3-11*

### 3-4. ENGINE DISASSEMBLY

#### NOTICE:

- Observe critically before starting to remove a component or part by loosening bolts, nuts and the like. What you may find before and during disassembly is valuable information necessary for successful reassembly.
- Be careful in handling aluminum-alloy parts. They are softer than steel or cast-iron parts and their finished surfaces more easily take scratch marks.
- Have trays and pans ready for setting aside disassembled parts in an orderly manner. Place parts in trays and pans in such a way that they can be readily identified. Put match marks or tags on them, as necessary, so that they will go back to where they came from.

Carry out engine disassembly in the following sequence:

- 1) Loosen drain plug and drain out engine oil.

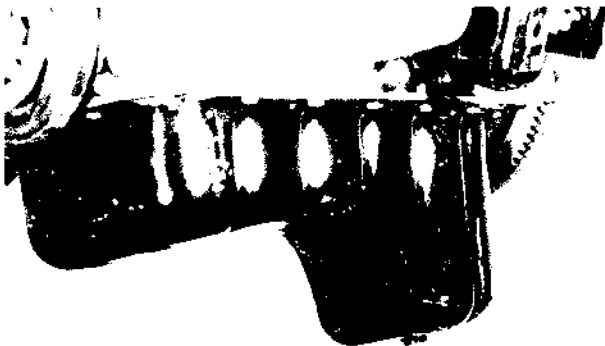


Fig. 3-4-1

- 2) Remove clutch cover and clutch disc.

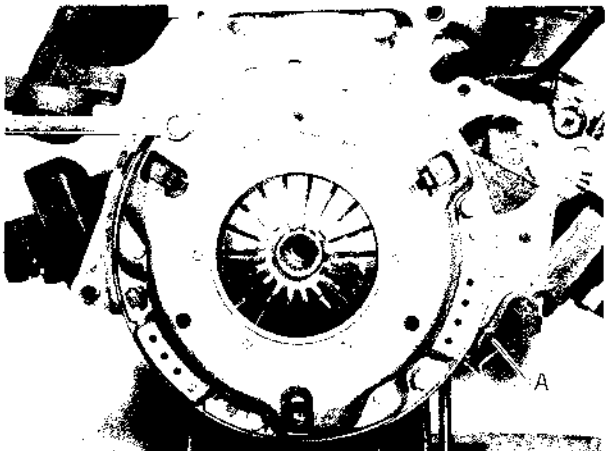


Fig. 3-4-2 (A) Flywheel holder (Special tool 09924-17810)

- 3) Remove distributor assembly.

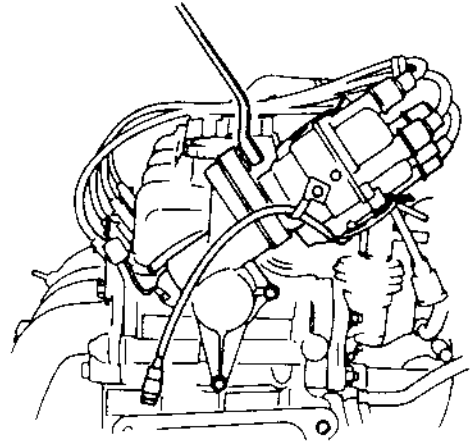


Fig. 3-4-3

- 4) Remove the fuel pump and rod.

#### NOTICE:

When removing pump and distributor gear case, place waste or receiver under gear case.

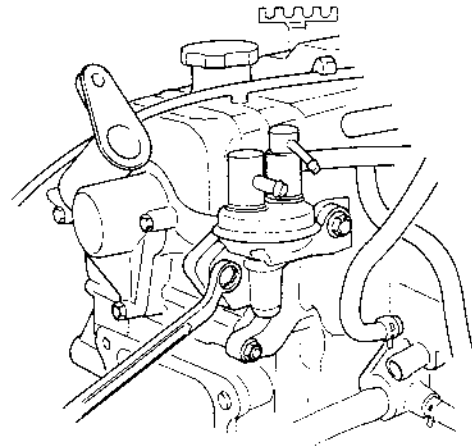


Fig. 3-4-4

- 5) Take down distributor case.



Fig. 3-4-5

6) Take down alternator and water pump pulley.

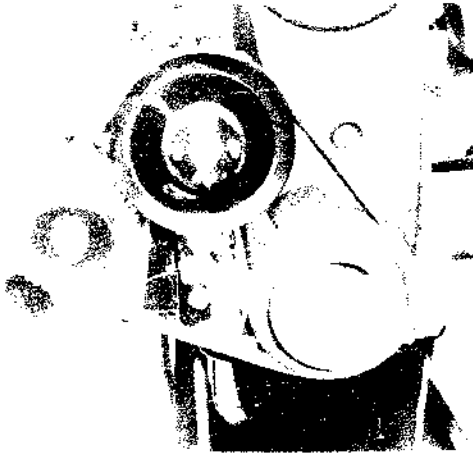


Fig. 3-4-6

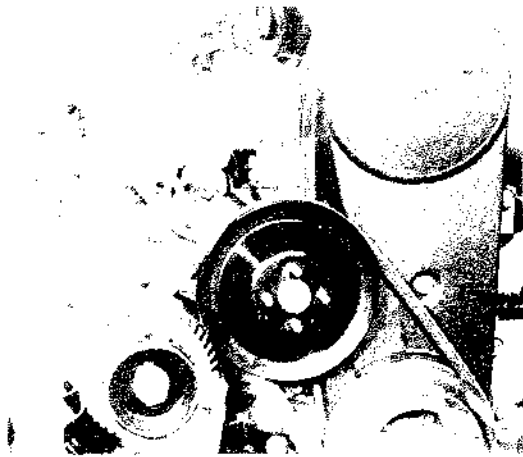
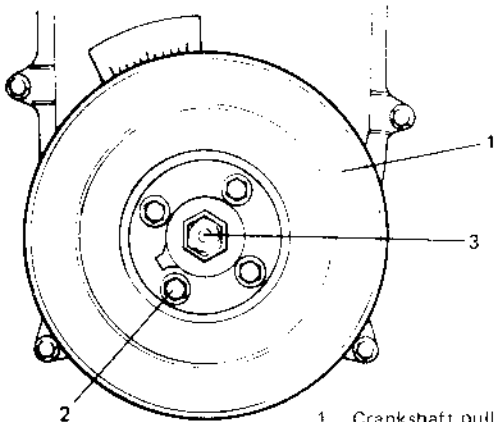


Fig. 3-4-7

7) Remove crankshaft pulley by removing 4 pulley bolts, with special tool (A) hitched to flywheel so that crankshaft will not turn. The crank timing belt pulley bolt at the center needs not to be loosened.



1. Crankshaft pulley
2. Crankshaft pulley bolt
3. Crank timing belt pulley bolt

Fig. 3-4-8

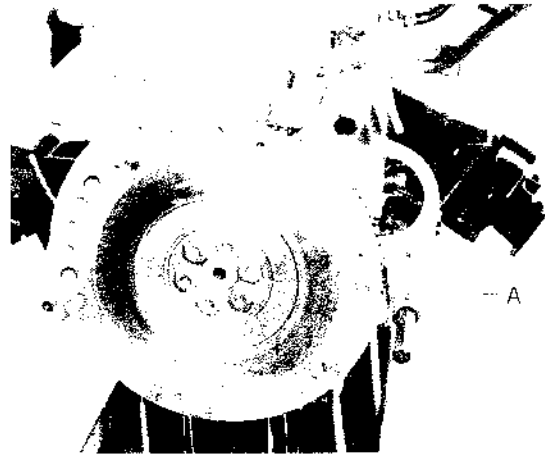


Fig. 3-4-9 (A) Flywheel holder (Special tool 09924-17810)

8) Remove outside cover on timing belt.

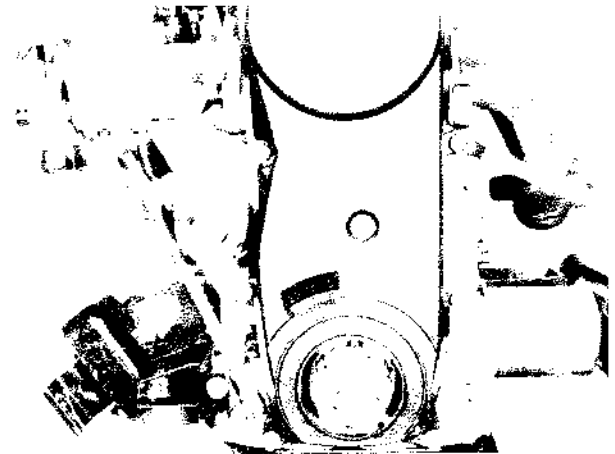
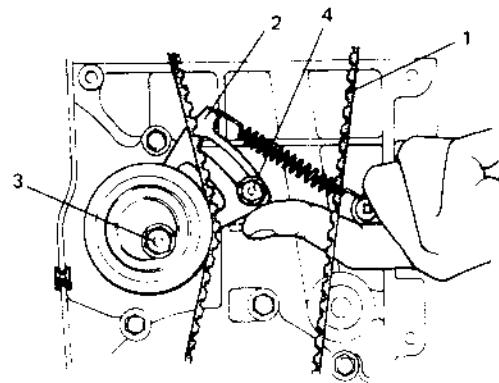


Fig. 3-4-10

9) Loosen tensioner bolt and stud, and remove belt from crank timing belt pulley and camshaft pulley after pushing up tensioner plate fully by finger as shown in Figure 3-4-11.

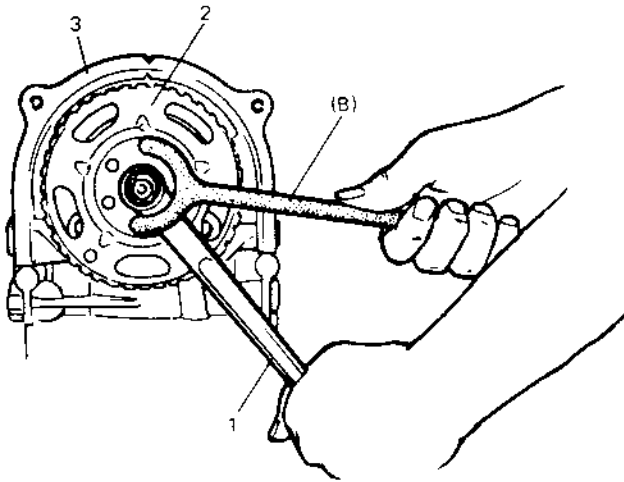


1. Timing belt
2. Tensioner plate
3. Tensioner bolt
4. Tensioner stud

Fig. 3-4-11



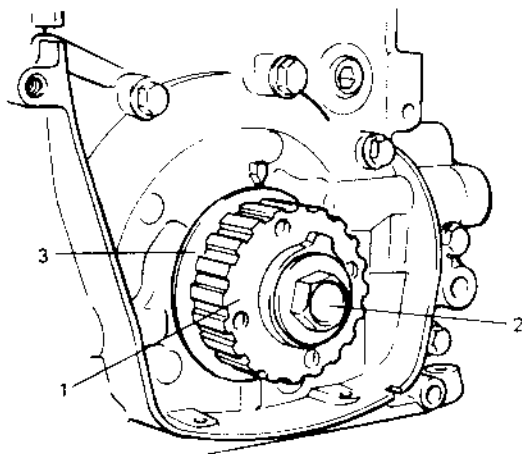
- 10) Remove timing belt tensioner, tensioner plate, and tensioner spring.
- 11) Remove camshaft timing belt pulley by using camshaft lock holder (B) (special tool) as shown.



- (B) Camshaft lock holder  
(Special tool 09917-68210)
1. Wrench
  2. Camshaft timing belt pulley
  3. Timing belt inside cover

Fig. 3-4-12

- 12) Using flywheel holder (A) (Special tool), remove crankshaft timing belt pulley bolt, pulley and timing belt guide with crankshaft locked.



1. Crankshaft timing belt pulley
2. Pulley bolt
3. Timing belt guide

Fig. 3-4-13

- 13) Remove crankshaft timing belt pulley key.
- 14) Remove timing belt inside cover.

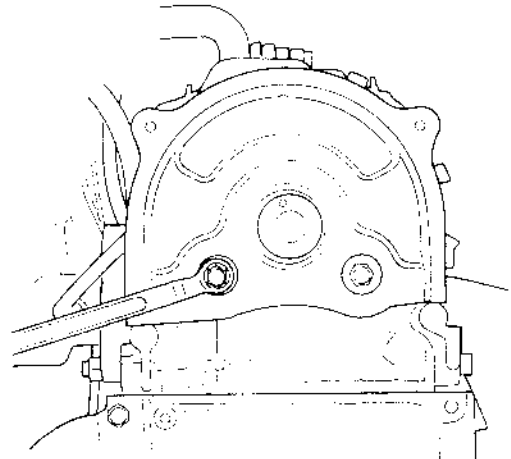


Fig. 3-4-14

- 15) Remove water pump.

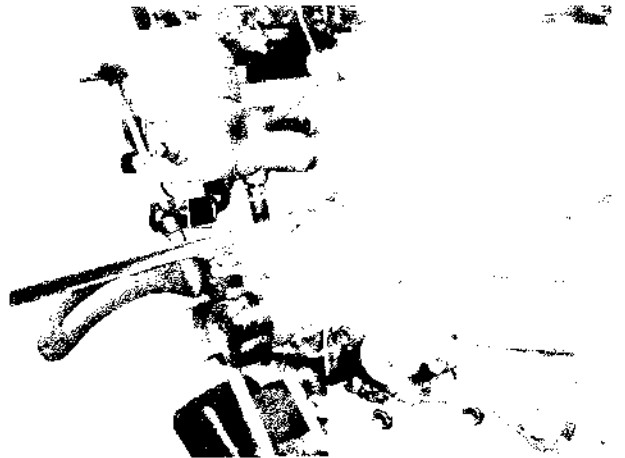


Fig. 3-4-15

- 16) Remove exhaust manifold cover.
- 17) Take off exhaust manifold and its gasket.

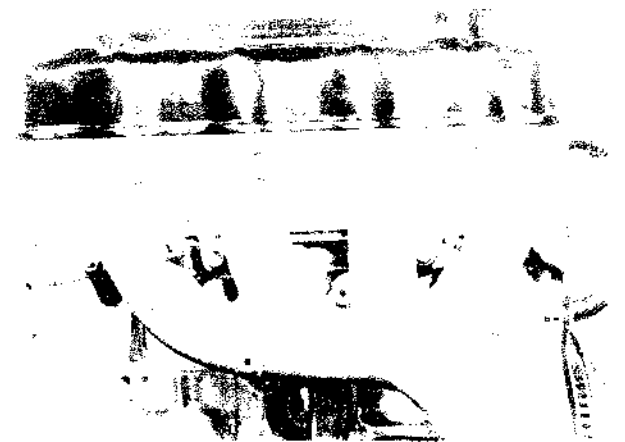


Fig. 3-4-16

18) Using special tool (C), remove oil filter.

**NOTICE:**

Be careful not to spill oil when removing filter.

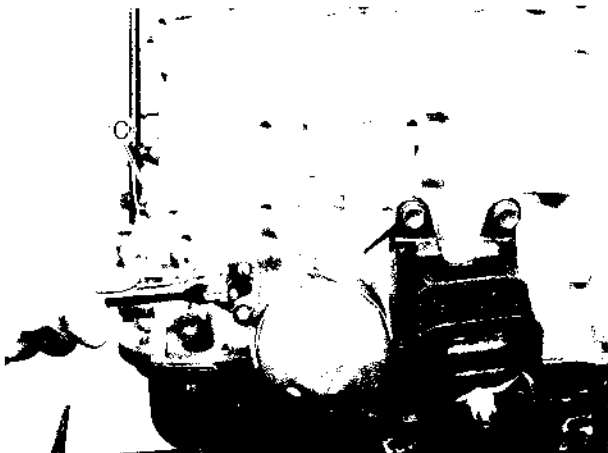


Fig. 3-4-17 (C) Oil filter wrench (09915-47310)

19) Draw water hoses off water pump inlet pipe.



Fig. 3-4-18

20) Disconnect PCV (Positive crankcase ventilation valve) hose from cylinder head cover.

21) Take down intake manifold with carburetor.

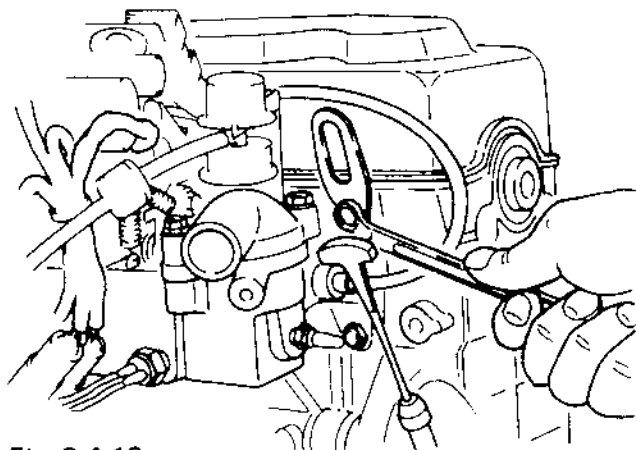


Fig. 3-4-19

22) Remove water inlet pipe.



Fig. 3-4-20

23) Take off cylinder head cover.



Fig. 3-4-21

24) Loosen 8 valve adjusting screws fully. Leave screws in place.

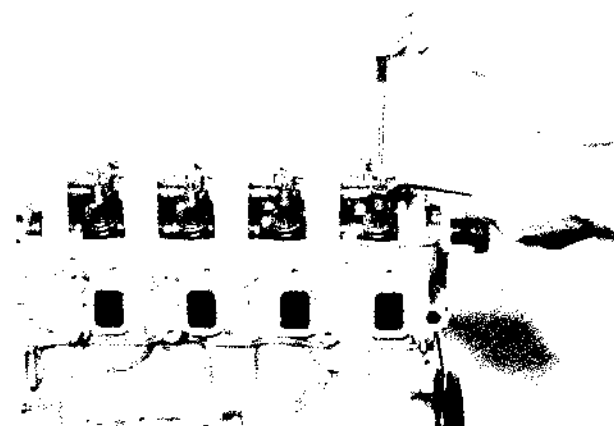


Fig. 3-4-22

25) Loosen rocker arm shaft securing screws (10 pcs).

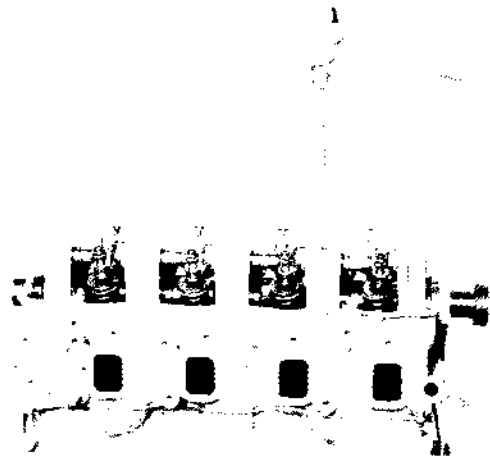


Fig. 3-4-23

26) While drawing out rocker arm shaft, separate valve rocker arms and rocker arm springs.

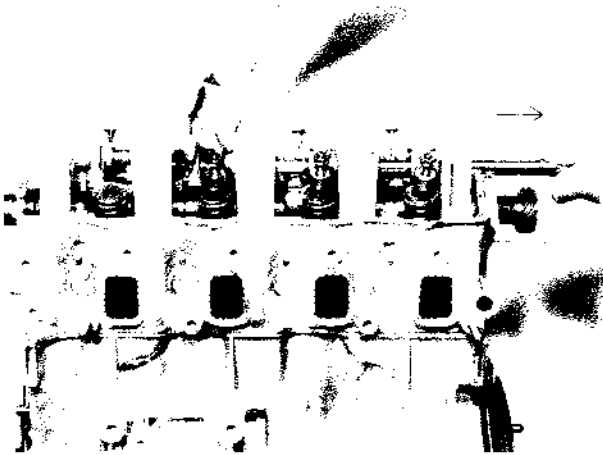


Fig. 3-4-24

27) Draw camshaft out toward rear end (transmission case side).

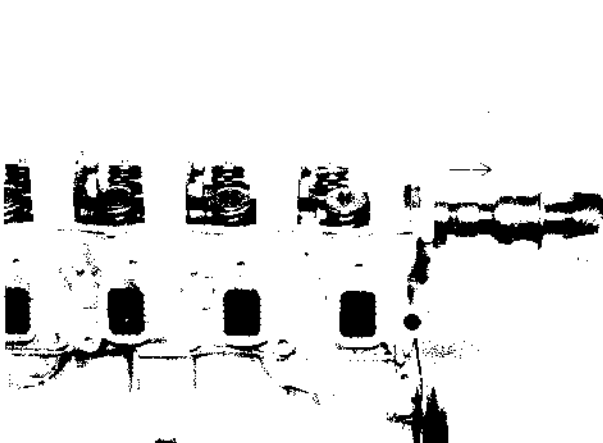


Fig. 3-4-25

28) Remove cylinder head.

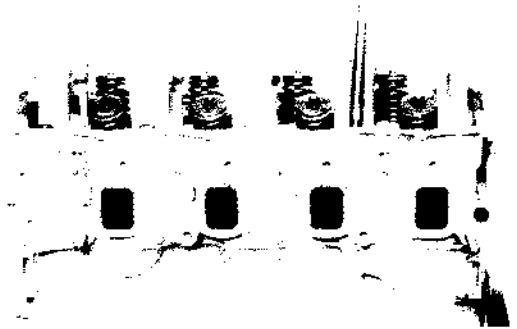
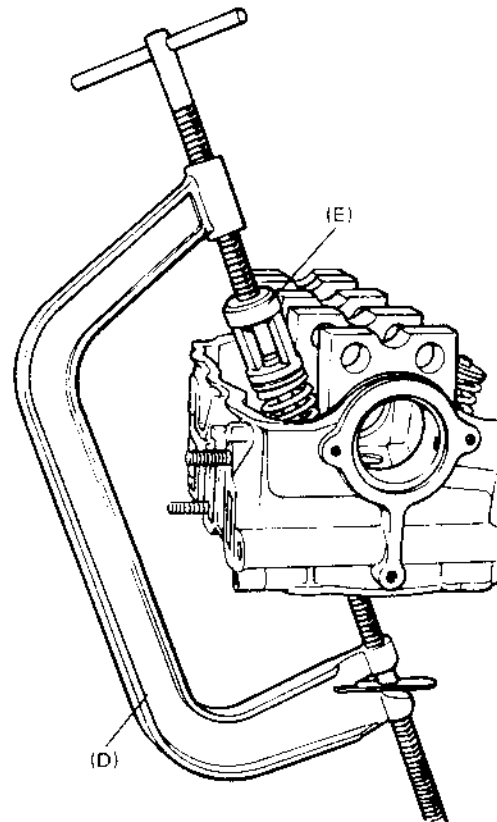


Fig. 3-4-26

a) Use valve lifter (D), (E) to compress valve spring in order to free valve cotter pieces for removal. In this way, remove valve spring and valves.



(D) Valve lifter  
(Special tool 09916-14510)

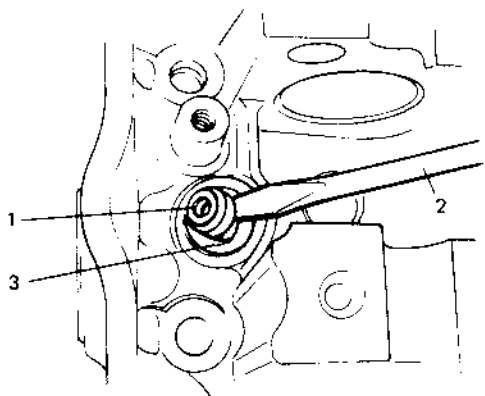
(E) Valve lifter attachment  
(Special tool 09916-48210)

Fig. 3-4-27

b) Remove valve stem oil seal from valve guide, and then valve spring seat.

**NOTICE:**

Do not reuse oil seal once disassembled. Be sure to use new oil seal when assembling.



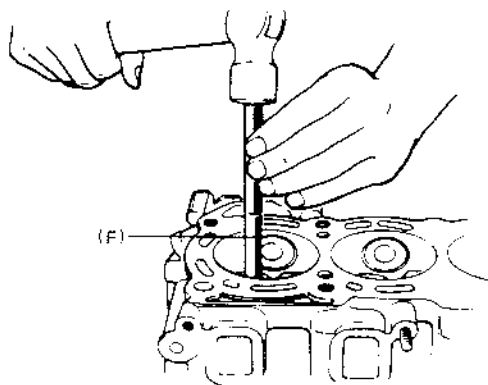
- 1. Valve stem oil seal
- 2. Blade screw driver
- 3. Valve spring seat

Fig. 3-4-28

c) Using special tool (F), drive valve guide out from combustion chamber side to valve spring side (Figure 3-4-29).

**NOTICE:**

Do not reuse valve guide once disassembled. Be sure to use new valve guide (Oversize) when assembling.



- (F) Valve guide remover (Special tool 09916-44511)

Fig. 3-4-29

**NOTICE:**

Place disassembled parts except valve stem seal and valve guide in order, so that they can be installed in their original positions.

29) Remove flywheel, using special tool (A) as shown.

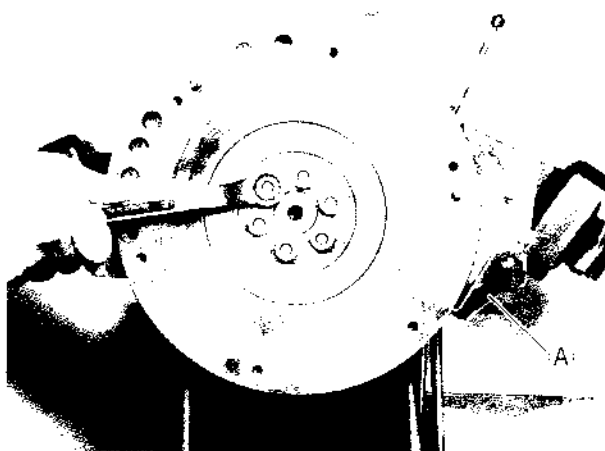


Fig. 3-4-30 (A) Flywheel holder (Special tool 09924-17810)

30) Remove oil level gauge guide from oil pump.

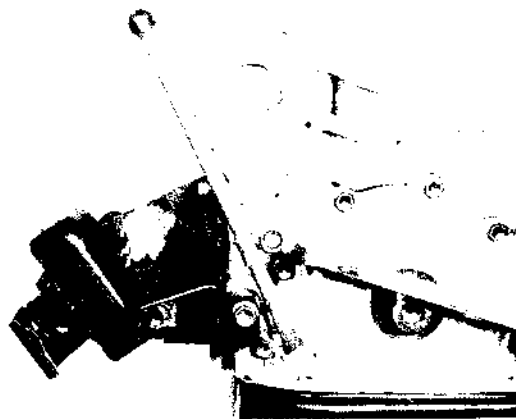


Fig. 3-4-31

31) Take down oil pan.

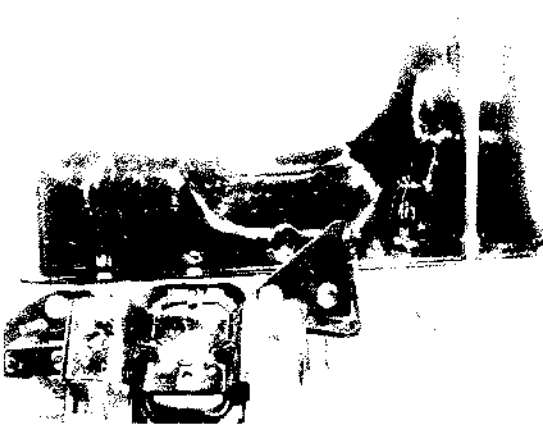


Fig. 3-4-32

32) Remove oil pump strainer.

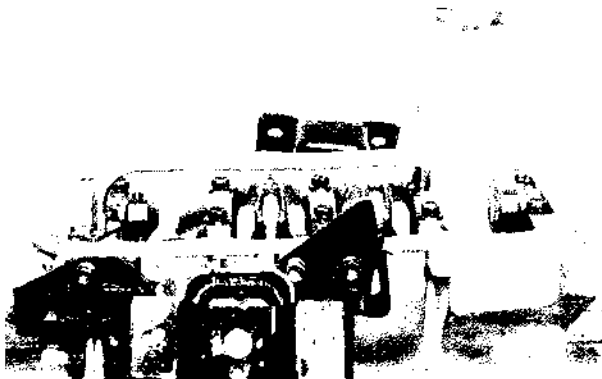


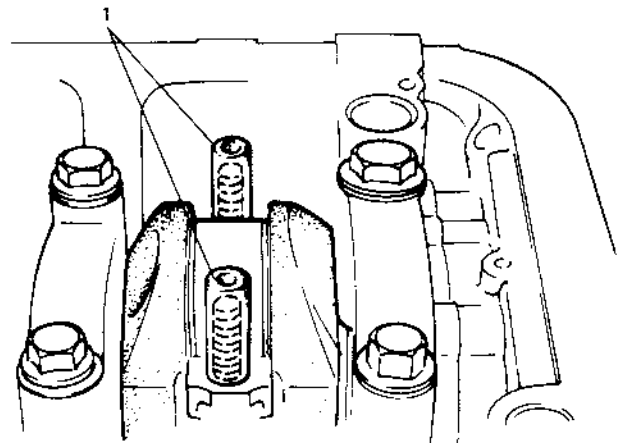
Fig. 3-4-33

33) Remove connecting rod bearing caps.



Fig. 3-4-34

34) Install guide hose over threads of rod bolts.  
This is to prevent damage to bearing journal and cylinder wall when removing connecting rod.



1. Guide hoses

Fig. 3-4-35

35) Decarbon top of cylinder bore, before removing piston from cylinder.

36) Push piston and connecting rod assembly out through the top of cylinder bore.

**CAUTION:**

- Before pulling piston out, scribe cylinder number on its crown.
- Be sure to identify each bearing cap for its connecting rod by using cylinder number. Set cap and rod aside in combination.

- a) Using piston ring expander, remove two compression rings (Top and 2nd) and oil ring from piston.
- b) Remove piston pin from connecting rod.  
Fit piston and connecting rod assembly to special tool (Fig. 3-4-36), and then press piston pin out of connecting rod by using arbor press (Fig. 3-4-37).

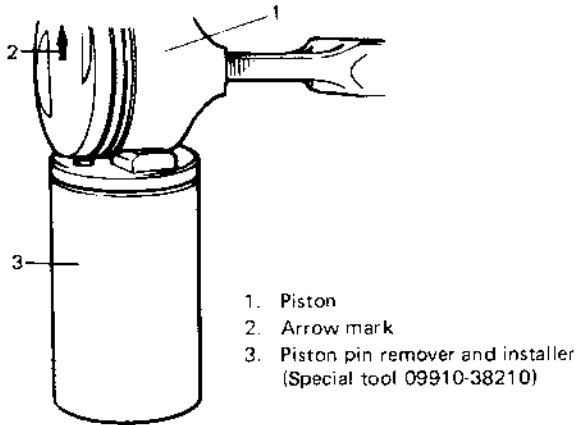


Fig. 3-4-36

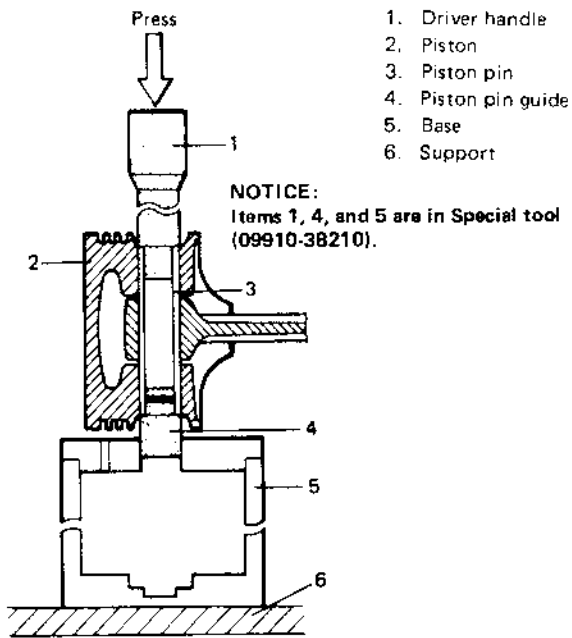


Fig. 3-4-37

37) Remove oil pump assembly.

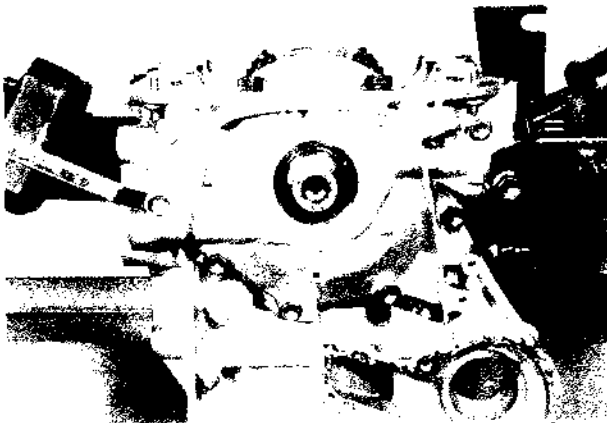
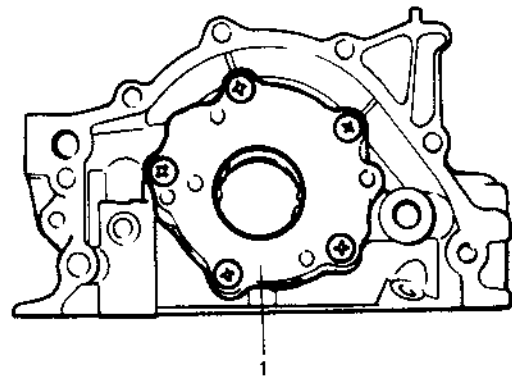


Fig. 3-4-38

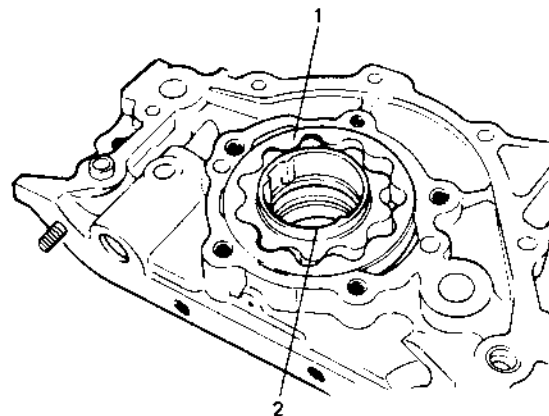
a) Remove oil pump rotor plate.



1. Rotor plate

Fig. 3-4-39

b) Remove outer rotor and inner rotor.



1. Outer rotor  
2. Inner rotor

Fig. 3-4-40

38) Remove oil seal housing.

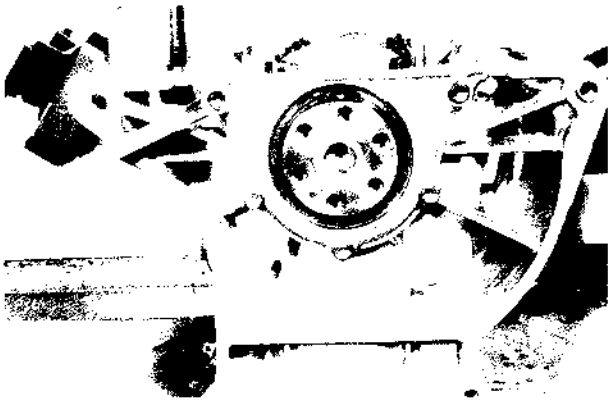


Fig. 3-4-41

39) Remove crankshaft bearing caps, and take out crankshaft.

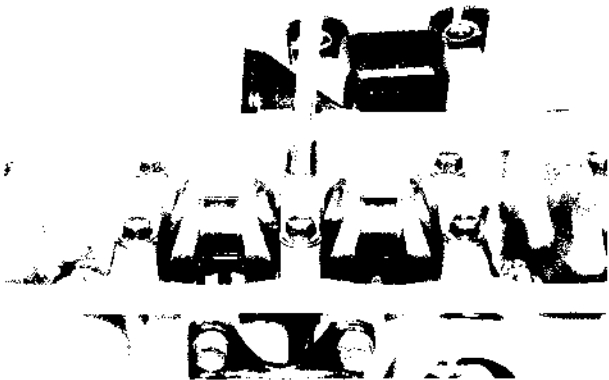


Fig. 3-4-42

### 3-5. INSPECTION OF ENGINE COMPONENTS

#### NOTICE:

- During and immediately after disassembly, inspect cylinder block and head for evidence of water leakage or damage and, after washing them clean, inspect more closely.
- Wash all disassembled parts clean, removing grease, slime, carbon and scales, before inspecting them to determine whether repair is necessary or not. Be sure to de-scale water jackets.
- Use compressed air to clear internal oil holes and passages.
- Do not disturb set combinations of valves, bearings and bearing caps, etc. Have the sets segregated and identified.

#### Cylinder Head

- Remove all carbon from combustion chambers.

#### NOTICE:

Do not use any sharp-edged tool to scrape off the carbon. Be careful not to scuff or nick metal surfaces when de-carboning. This applies to valves and valve seats, too.

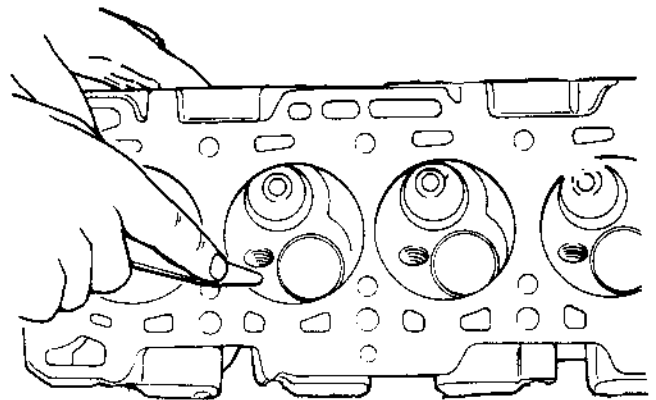


Fig. 3-5-1

- Check cylinder head for cracks in intake and exhaust ports, combustion chambers, and head surface.

- Flatness of gasketed surface:

Using a straightedge and thickness gauge, check surface at a total of 6 locations. If the limit stated below, is exceeded, correct gasketed surface with a surface plate and abrasive paper of about # 400 (Waterproof silicon carbide abrasive paper): place paper on and over surface plate, and rub gasketed surface against paper to grind off high spots. Should this fail to reduce thickness gauge readings to within the limit, replace cylinder head.

Leakage of combustion gases from this gasketed joint is often due to a warped gasketed surface; such leakage results in reduced power output.

Limit of distortion	0.05 mm (0.002 in.)
---------------------	---------------------

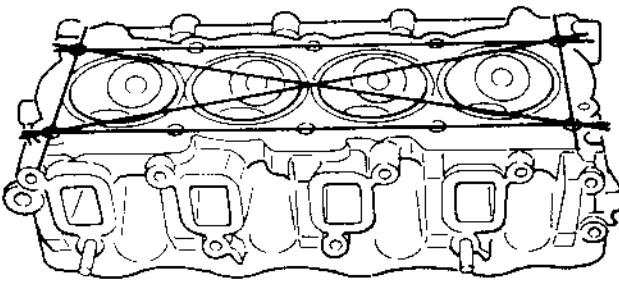


Fig. 3-5-2

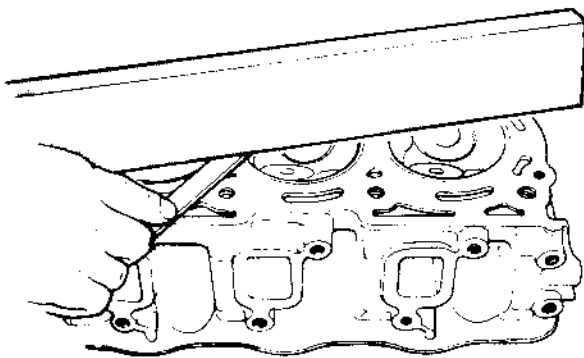


Fig. 3-5-3

- Distortion of manifold seating faces:

Check seating faces of cylinder head for manifolds, using a straightedge and thickness gauge, in order to determine whether these faces should be corrected or cylinder head replaced.

Limit of distortion	0.10 mm (0.004 in.)
---------------------	---------------------

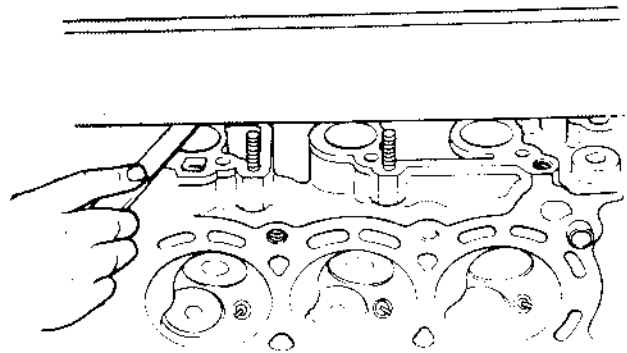


Fig. 3-5-4 Intake manifold seating face

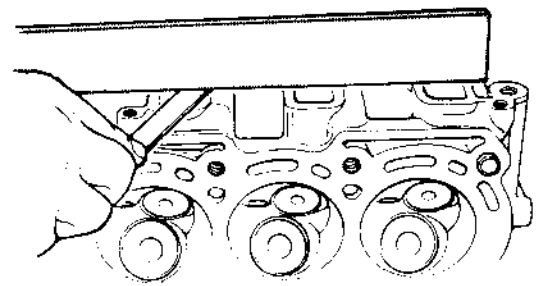


Fig. 3-5-5 Exhaust manifold seating face



### Rocker-Arm Shaft and Rocker Arms

- Shaft-to-arm clearance (IN & EX):

Using a micrometer and a bore gauge, measure rocker shaft dia. and rocker arm I.D..

The difference between two readings is the arm-to-shaft clearance on which limit is specified.

If the limit is exceeded, replace shaft or arm, or both.

Item	Standard	Limit
Rocker arm I.D.	16.000 – 16.018 mm (0.629 – 0.630 in.)	—
Rocker arm Shaft dia.	15.973 – 15.988 mm (0.628 – 0.629 in.)	—
Arm-to-Shaft clearance	0.012 – 0.045 mm (0.0005 – 0.0017 in.)	0.09 mm (0.0035 in.)

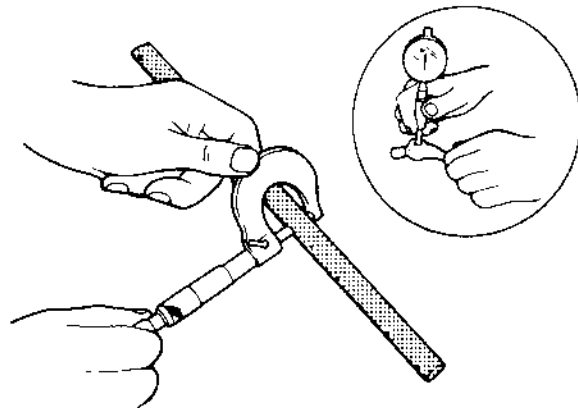


Fig. 3-5-6

- Runout of rocker-arm shaft:

Using "V" blocks and dial gauge, check runout. If runout exceeds the limit, replace rocker arm shaft.

Runout limit	0.12 mm (0.004 in.)
--------------	---------------------

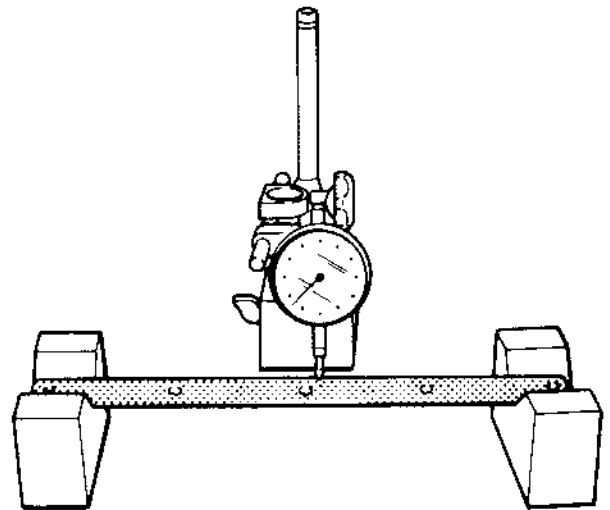
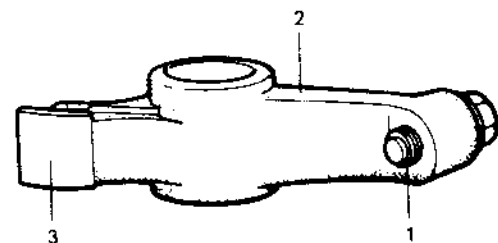


Fig. 3-5-7

- Wear of rocker-arm and adjusting screw:  
If the tip ① of adjusting screw is badly worn, replace screw. Arm must be replaced if its cam-riding face ③ is badly worn.



1. Adjusting screw
2. Rocker arm
3. Cam-riding face

Fig. 3-5-8

### Valve Guides

Using a micrometer and bore gauge, take diameter readings on valve stems and guides to determine stem clearance in guide. Be sure to take a reading at more than one place along the length of each stem and guide.

Item		Standard	Limit
Valve stem diameter	In	6.965 – 6.980 mm (0.2742 – 0.2748 in.)	—
	Ex	6.950 – 6.965 mm (0.2737 – 0.2742 in.)	—
Valve guide I.D.	In	7.000 – 7.015 mm (0.2756 – 0.2761 in.)	—
	Ex.	7.000 – 7.015 mm (0.2756 – 0.2761 in.)	—
Stem-to-guide clearance	In	0.020 – 0.050 mm (0.0008 – 0.0019 in.)	0.07 mm (0.0027 in.)
	Ex	0.035 – 0.065 mm (0.0014 – 0.0025 in.)	0.09 mm (0.0035 in.)

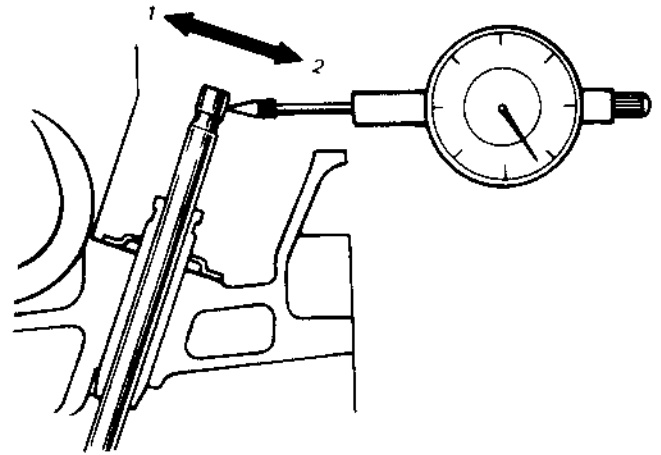


Fig. 3-5-10

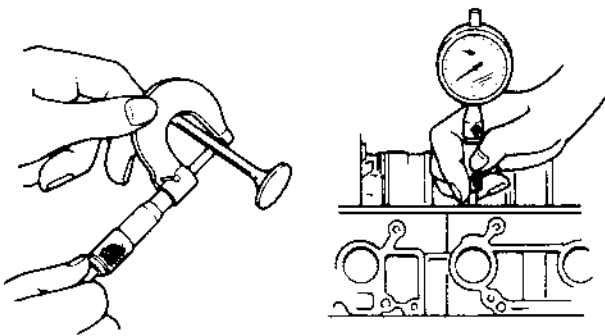


Fig. 3-5-9

If bore gauge is not available, check end deflection of the valve stem in place with a dial gauge rigged.

Move stem end in the directions ① and ② to measure end deflection.

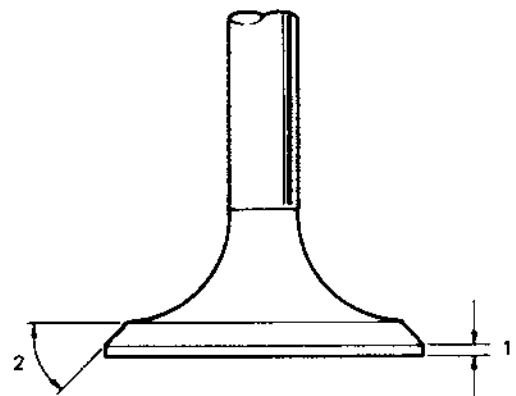
If deflection exceeds its limit, replace valve stem and valve guide.

Valve stem end deflection limit	In	0.14 mm (0.005 in.)
	Ex	0.18 mm (0.007 in.)

### Valves

- Remove all carbon from valves.
- Inspect each valve for wear, burn or distortion at its face and stem and replace as necessary.
- Measure thickness of valve head. If measured thickness exceeds its limit specified below, replace valve.

Valve head thickness		
Standard	Limit	
1.0 mm (0.039 in.)	In	0.6 mm (0.023 in.)
	Ex	0.7 mm (0.027 in.)



1. Valve head thickness
2. 45°

Fig. 3-5-11

- Check end face of each valve stem for wear. This face meets rocker arm intermittently in operation, and might become concaved or otherwise irregular. As necessary, smoothen the end face with an oil stone and, if this grinding removes the end stock by as much as 0.5 mm (0.0196 in.) (as measured from the original face), replace the valve.

Limit on stock allowance of valve stem end face	0.5 mm (0.0196 in.)
---	---------------------

- Check each valve for radial runout with a dial gauge and "V" block. To check runout, rotate valve slowly. If runout exceeds limit, replace valve.

Limit on valve head radial runout	0.08 mm (0.003 in.)
-----------------------------------	---------------------

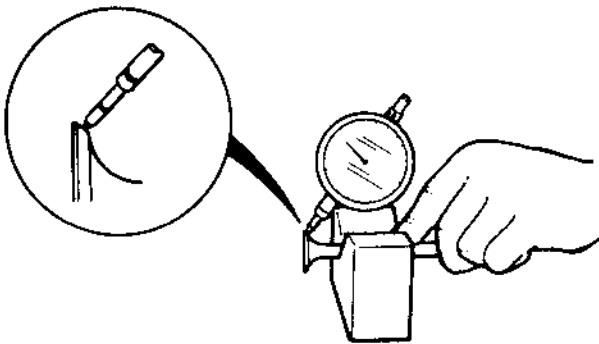


Fig. 3-5-12

### Valve Seats

#### CAUTION:

Valves to be checked and serviced for seating width and contact pattern must be those found satisfactory in regard to stem clearance in the guide and also requirements stated on preceding page under valves.

- Seating contact width:  
Produce contact pattern on each valve in the usual manner, namely, by giving uniform coat of marking compound to valve seat and by rotatingly tapping seat with valve head. Valve lapper (tool used in valve lapping) must be used.

The pattern produced on seating face of valve must be a continuous ring without any break, and width  $\text{\textcircled{W}}$  of pattern must be within stated range as follows.

Standard seating width revealed by contact pattern on valve face	Intake	1.3 – 1.5 mm
	Exhaust	(0.0512 – 0.0590 in.)

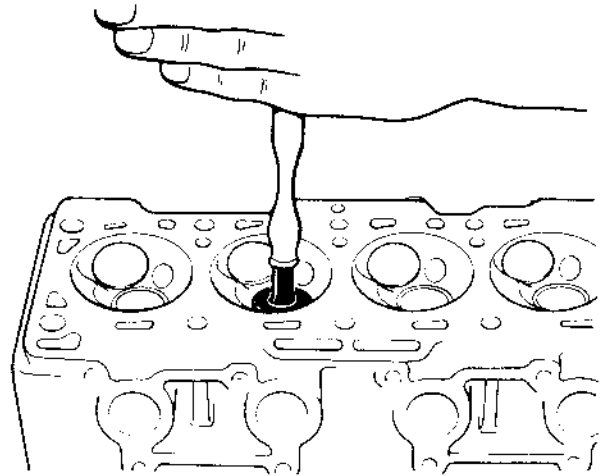
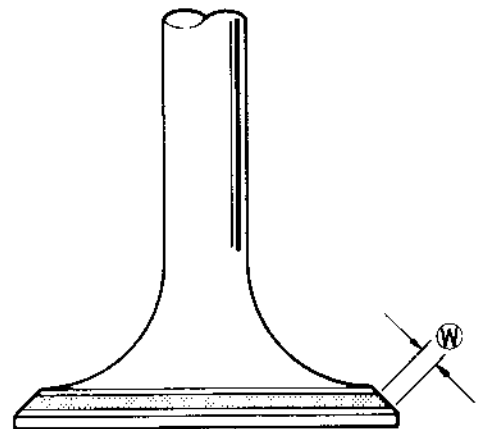


Fig. 3-5-13



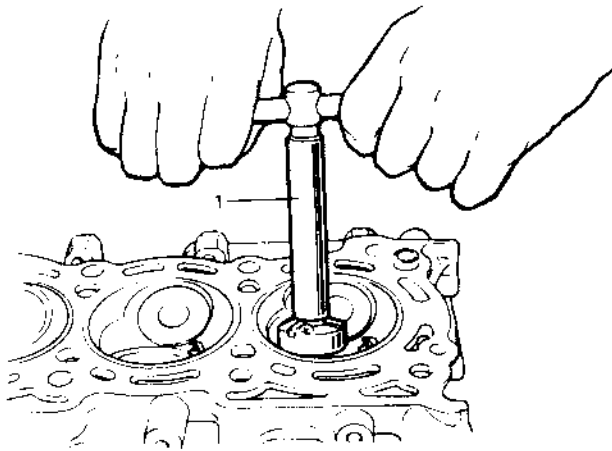
$\text{\textcircled{W}}$  Valve seat contact width

Fig. 3-5-14

- Valve seat repair:  
Valve seat not producing uniform contact with its valve or showing width  $\text{W}$  of seating contact that is off the specified range must be repaired by regrinding or by cutting and regrinding and finished by lapping.

1) EXHAUST VALVE SEAT: Use a valve seat cutter to make three cuts as illustrated in Fig. 3-5-16. Three cutters must be used: the first for making 15° angle, the second for making 75° angle and the last for making 45° seat angle. The third cut must be made to produce desired seat width  $\text{W}$ .

Seat width $\text{W}$ for exhaust valve seat	1.3 – 1.5 mm (0.0512 – 0.0590 in.)
--	---------------------------------------



1. Valve seat cutter

Fig. 3-5-15 Valve seat cutting

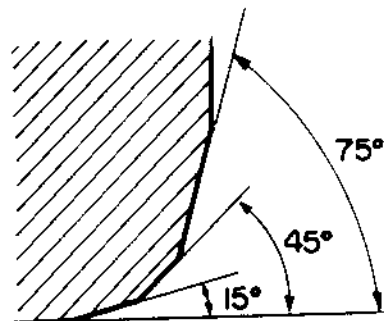


Fig. 3-5-16 Valve seat angles for exhaust valve

2) INLET VALVE SEAT: Cutting sequence is the same as for exhaust valve seats but the second angle is (60°).

Seat width $\text{W}$ for inlet valve seat	1.3 – 1.5 mm (0.0512 – 0.0590 in.)
--	---------------------------------------

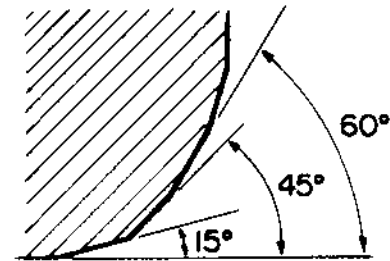


Fig. 3-5-17 Valve seat angles for intake valve

3) VALVE LAPPING. Lap valve on seat in two steps, first with coarse-size lapping compound applied to its face and the second with a fine-size compound, each time using a valve lapper according to usual lapping method.

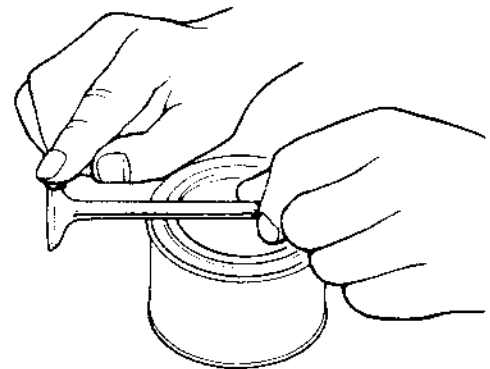


Fig. 3-5-18 Applying lapping compound to valve face

**NOTICE:**

- After lapping, wipe compound off valve face and seat, and produce contact pattern with marking compound. Check to be sure that contact is centered widthwise on valve seat and that there is no break in contact pattern ring.
- Be sure to check and, as necessary, adjust valve clearance after re-installing cylinder head and valve mechanism.

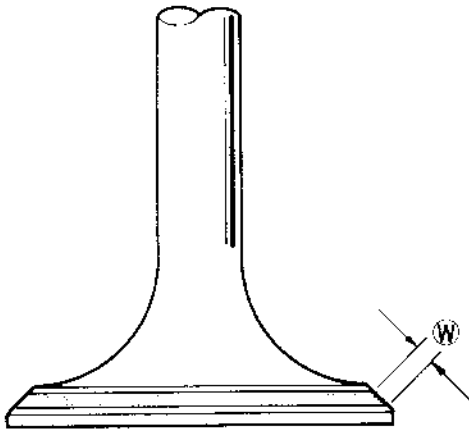


Fig. 3-5-19 Contact pattern  $\text{\textcircled{W}}$  uniform in width

### Valve Springs

- Referring to the criterion-data given below, check to be sure that each spring is in sound condition, free of any evidence of breakage or weakening. Remember, weakened valve springs can be the cause of chatter, not to mention the possibility of reducing power output due to gas leakage caused by decreased seating pressure.

Item	Standard	Limit
Valve spring free length	49.3 mm (1.9409 in.)	48.1 mm (1.8937 in.)
Valve spring preload	24.8 – 29.2 kg for 41.5 mm (54.7 – 64.3 lb/ 1.63 in.)	22.8 kg for 41.5 mm (50.2 lb/ 1.63 in.)

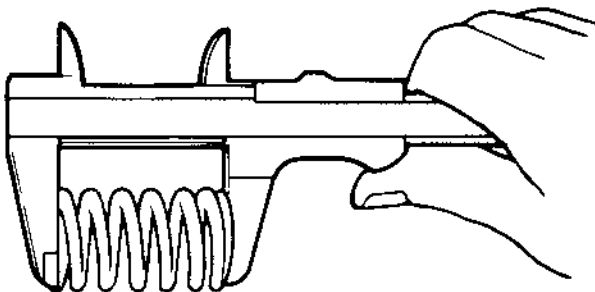


Fig. 3-5-20 Measuring free length of spring

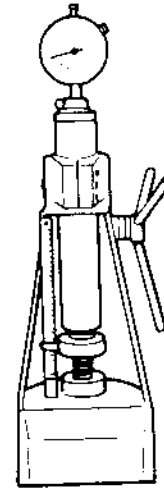


Fig. 3-5-21 Measuring spring preload

- Spring squareness:  
Use a square and surface plate to check each spring for squareness in terms of clearance between the end of valve spring and square. Valve springs found to exhibit a larger clearance than specified limit must be replaced.

Valve springs squareness limit	2.0 mm (0.079 in.)
--------------------------------	--------------------

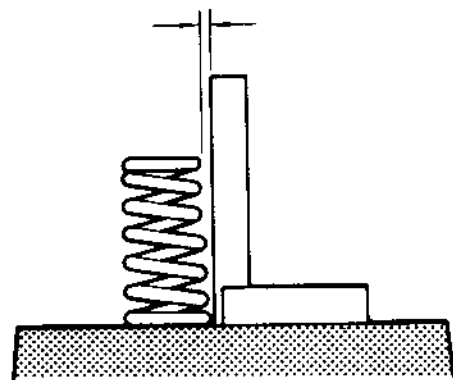


Fig. 3-5-22 Measuring spring squareness

### Camshaft

- Runout of camshaft:

Hold camshaft between two "V" blocks, and measure runout by using a dial gauge.

If runout exceeds its limit, replace camshaft.

Runout limit	0.10 mm (0.0039 in.)
--------------	----------------------

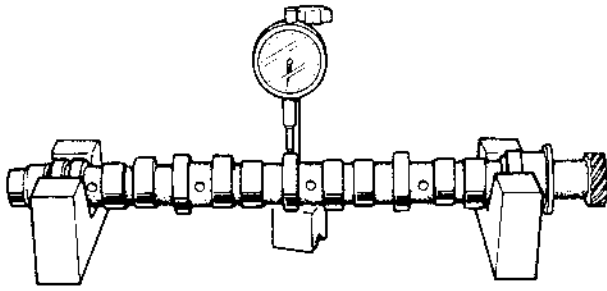


Fig. 3-5-23

- Cam wear:

Using a micrometer, measure height (H) of cam (lobe). If measured height is less than respective limits, replace camshaft.

Cam height	Standard	Limit
Intake cam	37.500 mm (1.4763 in.)	37.400 mm (1.4724 in.)
Exhaust cam	37.500 mm (1.4763 in.)	37.400 mm (1.4724 in.)
Fuel pump drive cam	40.000 mm (1.5748 in.)	39.600 mm (1.5590 in.)

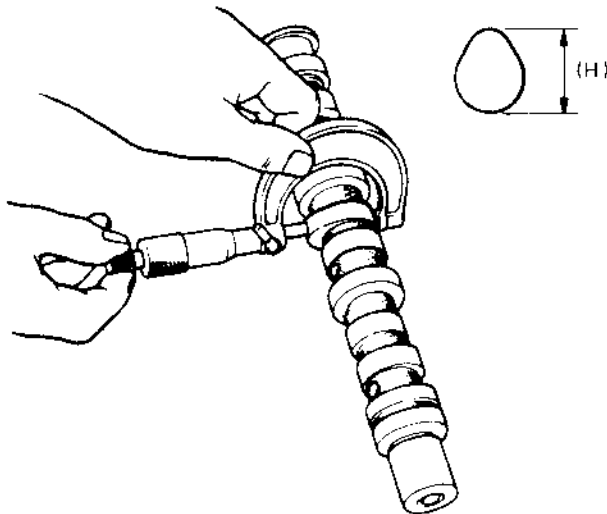


Fig. 3-5-24

- Journal wear:

Measure journal diameter in two directions at two places (total of 4 readings) on each journal as shown in Fig. 3-5-25, and also by using bore gauge, measure journal bore in cylinder head as shown in Fig. 3-5-26 (i.e. 4 readings on each journal).

Subtract journal diameter measurement from journal bore measurement to determine journal clearance.

If journal clearance exceeds its limit, replace camshaft, and as necessary, cylinder head, too.

	Standard	Limit
Journal clearance limit	0.050 – 0.091 mm (0.0020 – 0.0036 in.)	0.15 mm (0.0059 in.)

	Camshaft journal dia.	Journal bore dia.
Ⓐ	44.125 – 44.150 mm (1.7372 – 1.7381 in.)	44.200 – 44.216 mm (1.7402 – 1.7407 in.)
Ⓑ	44.325 – 44.350 mm (1.7451 – 1.7460 in.)	44.400 – 44.416 mm (1.7480 – 1.7486 in.)
Ⓒ	44.525 – 44.550 mm (1.7530 – 1.7539 in.)	44.600 – 44.616 mm (1.7560 – 1.7565 in.)
Ⓓ	44.725 – 44.750 mm (1.7609 – 1.7618 in.)	44.800 – 44.816 mm (1.7638 – 1.7644 in.)
Ⓔ	44.925 – 44.950 mm (1.7687 – 1.7697 in.)	45.000 – 45.016 mm (1.7716 – 1.7723 in.)

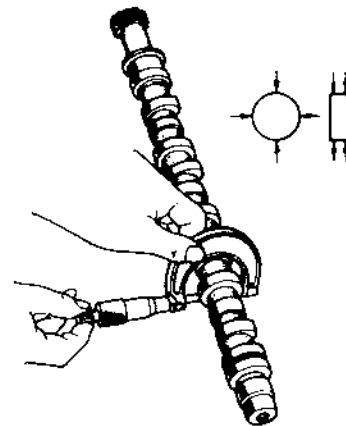
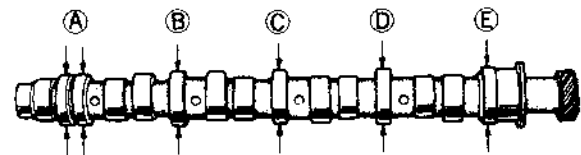


Fig. 3-5-25

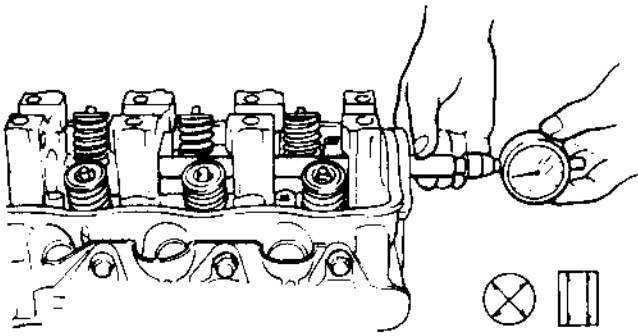


Fig. 3-5-26

### Cylinder Block

- Distortion of gasketed surface:  
Using a straightedge and a thickness gauge, check gasketed surface for distortion and, if result exceeds specified limit, correct it.

	Standard	Limit
Flatness	0.03 mm (0.0012 in.)	0.06 mm (0.0024 in.)

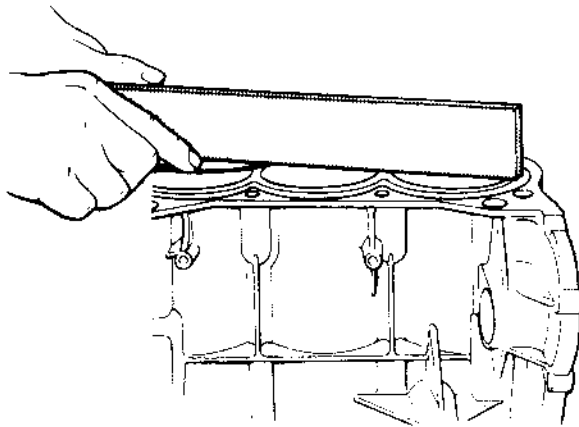


Fig. 3-5-27

- Cylinder bore:
  - 1) Inspect cylinder walls for scratches, roughness, or ridges which indicate excessive wear. If cylinder bore is very rough or deeply scratched, or ridged, rebore cylinder and use oversize piston.
  - 2) Using a cylinder gauge, measure cylinder bore in thrust and axial directions at two positions as shown in Fig. 3-5-28.  
If any of the following conditions exists, rebore cylinder.
    - Cylinder bore dia. exceeds its limit.
    - Difference of measurements at two positions exceeds taper limit.
    - Difference between thrust and axial measurements exceeds out-of-round limit.

Cylinder bore dia. limit	74.15 mm (2.9193 in.)
Taper and out-of-round limit	0.10 mm (0.0039 in.)

### NOTICE:

If any one of four cylinders has to be rebored, rebore all four to the same next oversize. This is necessary for the sake of uniformity and balance.

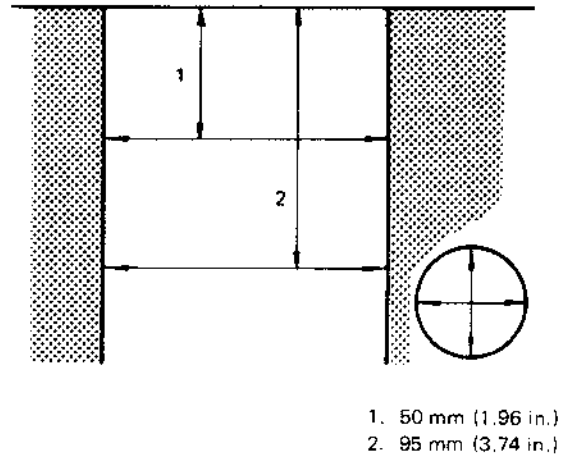


Fig. 3-5-28 Positions to be measured

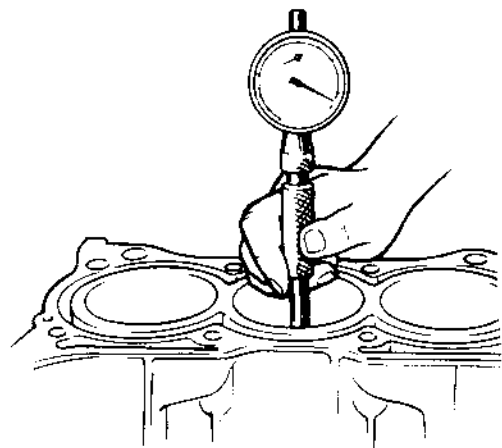


Fig. 3-5-29 Measuring cylinder bore with cylinder gauge

- Honing or reboring cylinders:

- 1) When any cylinder needs reboring, all other cylinders must also be rebored at same time.
- 2) Select oversized piston according to amount of cylinder wear.

Size	Piston diameter
O/S 0.25	74.220 – 74.230 mm (2.9220 – 2.9224 in.)
O/S 0.50	74.470 – 74.480 mm (2.9318 – 2.9322 in.)

- 3) Using micrometer, measure piston diameter.

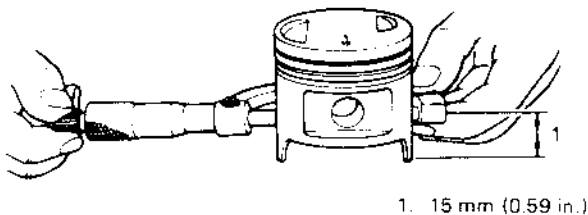


Fig. 3-5-30 Measuring piston diameter

- 4) Calculate cylinder bore diameter to be rebored.

$$D = A + B - C$$

D : Cylinder bore diameter to be rebored.

A : Piston diameter as measured.

B : Piston clearance = 0.02 – 0.04 mm  
(0.0008 – 0.0015 in)

C : Allowance for honing = 0.02 mm  
(0.0008 in)

- 5) Rebore and hone cylinder to calculated dimension.

**NOTICE:**

Before reboring, install all main bearing caps in place and tighten to specification to avoid distortion of bearing bores.

- 6) Measure piston clearance after honing.

**Piston and Piston Rings**

Clean carbon from piston head and ring grooves, using a suitable tool.

Inspect piston for faults, cracks or other damage. Damaged or faulty piston should be replaced.

- Piston diameter:

As indicated in Fig. 3-5-31, piston diameter should be measured at the height of 15 mm (0.59 in) from piston skirt end in the direction perpendicular to piston pin.

Piston diameter	Standard	73.970 – 73.990 mm (2.9122 – 2.9129 in.)
	Oversize: 0.25 mm (0.0098 in.)	74.220 – 74.230 mm (2.9220 – 2.9224 in.)
	0.50 mm (0.0196 in.)	74.47 – 74.48 mm (2.9319 – 2.9322 in.)

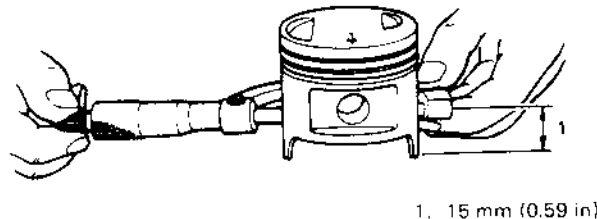


Fig. 3-5-31 Measuring piston diameter with micrometer

- Piston clearance:

To calculate piston clearance, measure cylinder bore diameter and piston diameter. The piston clearance is difference between cylinder bore diameter and piston diameter. Piston clearance should be within specification as follows.

If it is out of specification, rebore cylinder and use oversize piston.

Piston clearance	0.02 – 0.04 mm (0.0008 – 0.0015 in.)
------------------	---

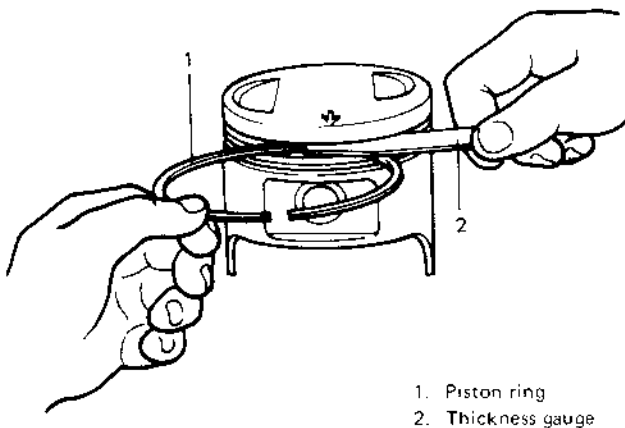
**NOTICE:**

Cylinder bore diameters measured in thrust direction at two positions as shown in Fig. 3-5-28 should be used for calculation of piston clearance.



- Ring groove clearance:  
Before checking, piston grooves must be clean, dry and free from carbon.  
Fit new piston ring into piston groove, and measure clearance between ring and ring land by using thickness gauge.  
If the clearance is out of specification, replace piston.

Ring groove clearance	Top	0.03 – 0.07 mm (0.0012 – 0.0027 in.)
	2nd	0.02 – 0.06 mm (0.0008 – 0.0023 in.)



1. Piston ring  
2. Thickness gauge

Fig. 3-5-32 Measuring ring groove clearance

- Piston ring end gap:  
To measure end gap, insert piston ring into cylinder bore, locating it at the lowest part of bore and holding it true and square; then use a feeler gauge to measure gap. If the gap exceeds its limit, replace ring.

**NOTICE:**

Decarbon and clean top of cylinder bore, before inserting piston ring.

Item	Standard	Limit
Piston ring end gap	Top ring 0.20 – 0.33 mm (0.0079 – 0.0129 in.)	0.7 mm (0.0275 in.)
	2nd ring 0.20 – 0.35 mm (0.0079 – 0.0137 in.)	0.7 mm (0.0275 in.)
	Oil ring 0.20 – 0.70 mm (0.0079 – 0.0275 in.)	1.8 mm (0.0708 in.)

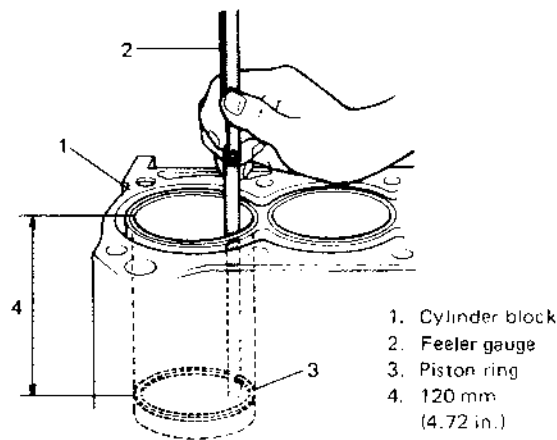


Fig. 3-5-33 Measuring piston ring end gap

**Piston Pins**

- Piston pin must be fitted into piston bore with an easy finger push at normal room temperature.
- Check piston pin and piston bore for wear or damage. If pin or piston bore is badly worn or damaged, replace pin or piston, or both.

**Connecting Rods**

- Big-end side clearance:  
Check big end of connecting rod for side clearance, with rod fitted and connected to its crank pin in the normal manner. If clearance measured is found to exceed its limit, replace connecting rod.

Item	Standard	Limit
Big-end side clearance	0.10 – 0.20 mm (0.0039 – 0.0078 in.)	0.35 mm (0.0137 in.)

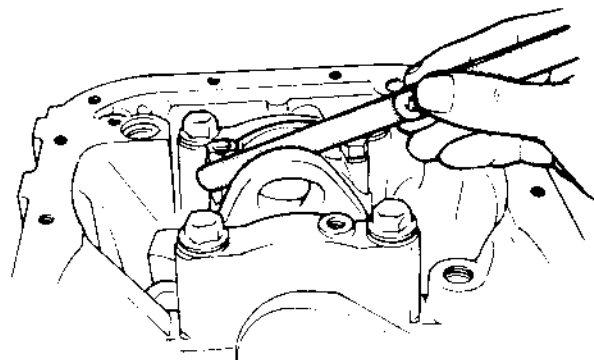


Fig. 3-5-34 Measuring side clearance

- Connecting rod alignment:  
Mount connecting rod on aligner to check it for bow and twist and, if either limit is exceeded, replace it.

Limit on bow	0.05 mm (0.0020 in.)
Limit on twist	0.10 mm (0.0039 in.)

### Crank Pin and Connecting Rod Bearings

- Inspect crank pin for uneven wear or damage. Measure crank pin for out-of-round or taper with a micrometer. If crank pin is damaged, or out-of-round or taper is out of limit, replace crankshaft or regrind crank pin to undersize and use undersize bearing.

Connecting rod bearing size	Crank pin diameter
Standard	41.982 – 42.000 mm (1.6529 – 1.6535 in.)
0.25 mm (0.0098 in.) undersize	41.732 – 41.750 mm (1.6430 – 1.6437 in.)

Out-of-round and taper limit	0.01 mm (0.0004 in.)
------------------------------	----------------------

- Rod bearing:  
Inspect bearing shells for signs of fusion, pitting, burn or flaking and observe contact pattern. Bearing shells found in defective condition must be replaced.  
Two kinds of rod bearing are available; standard size bearing and 0.25 mm undersize bearing. To distinguish them, 0.25 mm undersize bearing has stamped number (US025) on its backside as indicated in Fig. 3-5-35, but standard size one has no such number.

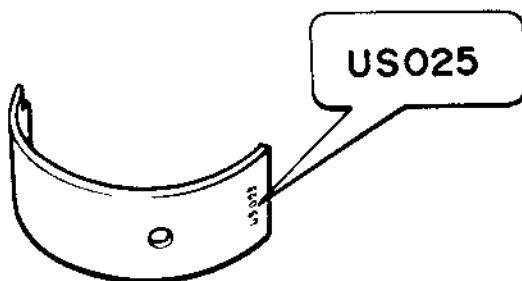


Fig. 3-5-35 0.25 mm undersize bearing

- Rod bearing clearance:
  - 1) Before checking bearing clearance, clean bearing and crank pin.
  - 2) Install bearing in connecting rod and bearing cap.
  - 3) Place a piece of gaging plastic to full width of the crankpin as contacted by bearing (parallel to the crankshaft), avoiding the oil hole.
  - 4) Install rod bearing cap to connecting rod. When installing cap, be sure to point arrow mark on cap to crankshaft pulley side, as indicated in Fig. 3-5-36. Tighten the cap nuts to the specified torque. DO NOT turn crankshaft with gaging plastic installed.

Tightening torque for rod bearing cap nuts	33 – 37 N·m 3.3 – 3.7 kg·m 24.0 – 26.5 lb·ft
--	--

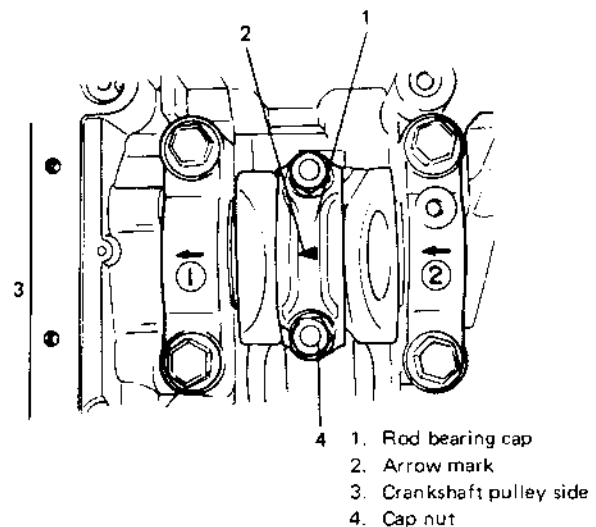


Fig. 3-5-36 Installing bearing cap

5) Remove cap and using scale on gaging plastic envelope, measure gaging plastic width at the widest point.

If the clearance exceeds its limit, use a new standard size bearing and remeasure clearance.

	Standard	Limit
Bearing clearance	0.030 – 0.050 mm (0.0012 – 0.0019 in.)	0.080 mm (0.0031 in.)

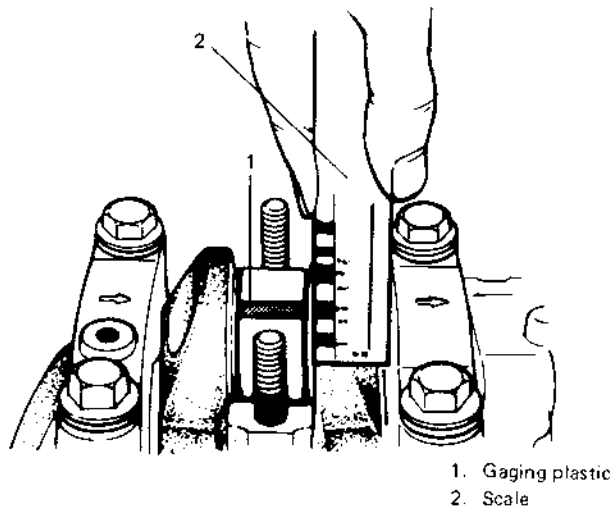


Fig. 3-5-37 Measuring rod bearing clearance

6) If clearance can not be brought to within limit even by using a new standard size bearing, regrind crankpin to the undersize and use 0.25 mm undersize bearing.

### Crankshaft

- Crankshaft runout:

Using a dial gauge, measure runout at center journal. Rotate crankshaft slowly. If runout exceeds limit, replace crankshaft.

Limit on runout	0.06 mm (0.0023 in.)
-----------------	----------------------

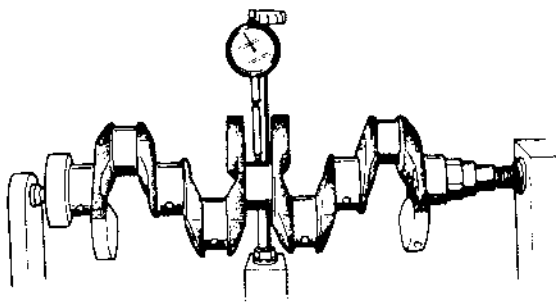


Fig. 3-5-38 Measuring runout

- Crankshaft thrust play:

Measure this play with crankshaft set in cylinder block in the normal manner, that is, with thrust bearing fitted and journal bearing caps installed. Tighten bearing cap bolts to specified torque.

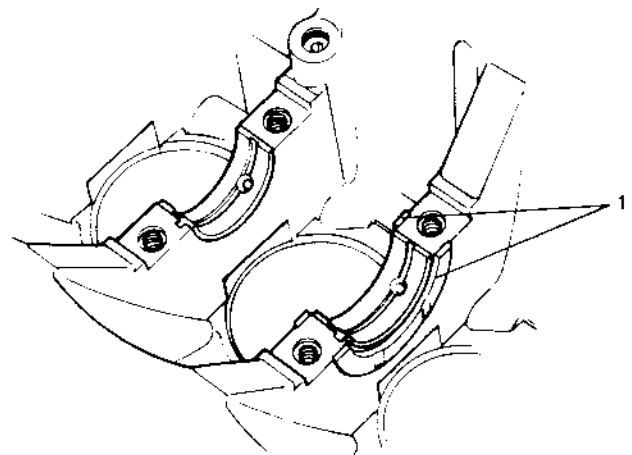
Use a dial gauge to read displacement in axial (thrust) direction of crankshaft.

If the limit is exceeded, replace thrust bearing with new standard one or oversize one to obtain standard thrust play.

Tightening torque for main bearing cap bolts	50 – 57 N·m 5.0 – 5.7 kg-m 36.5 – 41.0 lb-ft
--	--

Item	Standard	Limit
Crankshaft thrust play	0.11 – 0.31 mm (0.0044 – 0.0122 in.)	0.38 mm (0.0149 in.)

Thickness of crankshaft thrust bearing	Standard	2.50 mm (0.0984 in.)
	Oversize	2.563 mm (0.1009 in.)



1. Thrust bearing

Fig. 3-5-39 Thrust bearings

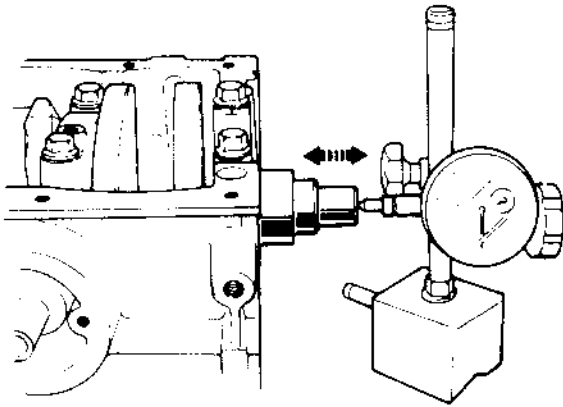


Fig. 3-5-40 Measuring thrust play of crankshaft

- **Out-of-round and taper (uneven wear):**  
An unevenly worn crankshaft journal shows up as a difference in diameter at a cross section or along its length (or both). This difference, if any, is to be determined from micrometer readings.  
If any of journals is badly damaged or if the amount of uneven wear in the sense explained above exceeds its limit, regrind or replace the crankshaft.

Limit on out-of-round and taper	0.01 mm (0.0004 in.)
---------------------------------	----------------------

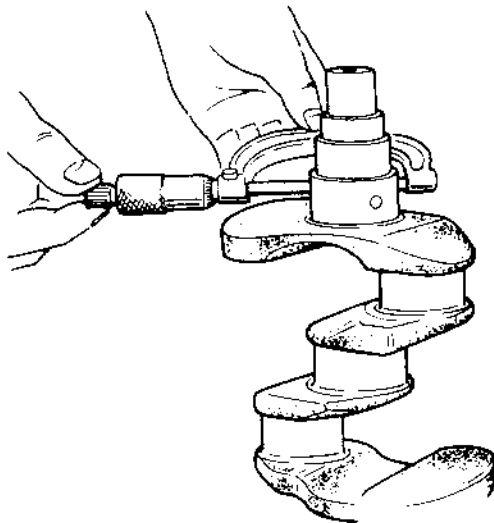


Fig. 3-5-41 Checking uneven wear

## Crankshaft Main (Journal) Bearings

### General informations:

- Service main bearings are available in standard-size and 0.25 mm (0.0098 in) undersize, and each of them has 5 kinds of bearings differing in tolerance.
- The upper half of bearing has oil groove as indicated in Fig. 3-5-42. Install this half with oil groove to cylinder block.

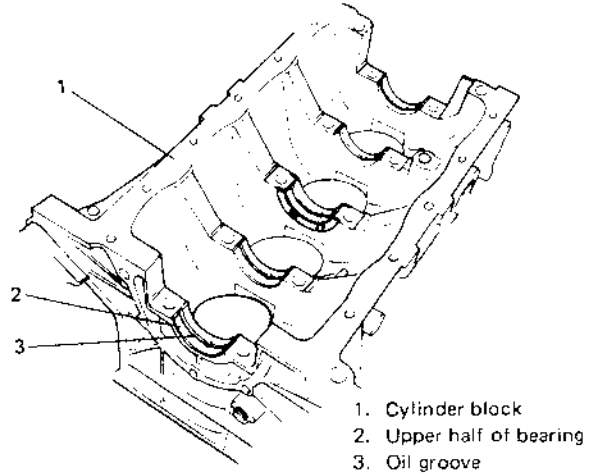


Fig. 3-5-42 Upper half of bearing installation

- On each main bearing cap, arrow mark and number are embossed as indicated in Fig. 3-5-43.  
When installing each bearing cap to cylinder block, point arrow mark toward crankshaft pulley side and install each cap from crankshaft pulley side to flywheel side in ascending order of numbers ①, ②, ③, ④ and ⑤. Tighten cap bolts to specified torque.

Tightening torque for main bearing cap bolt	50 – 57 N·m 5.0 – 5.7 kg·m 36.5 – 41.0 lb·ft
---	--

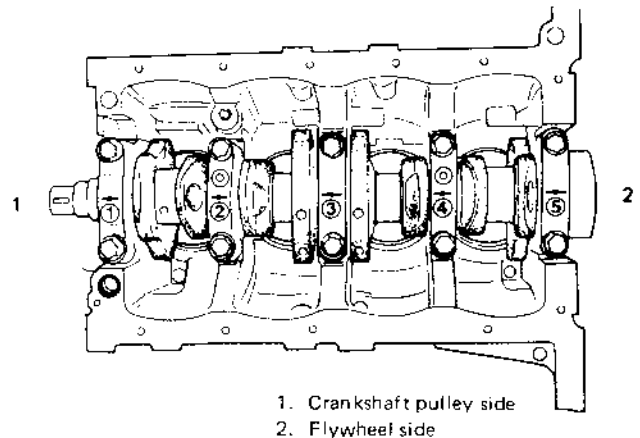


Fig. 3-5-43 Bearing caps installation

**Inspect:**

Check bearings for pitting, scratches, wear or damage. If any malcondition is found, replace both upper and lower halves. Never replace one half without replacing the other half.

**Main bearing clearance:**

Check clearance by using gaging plastic according to following procedure.

- 1) Remove bearing caps.
- 2) Clean bearings and main journals.
- 3) Place a piece of gaging plastic to full width of the bearing (parallel to the crankshaft) on journal, avoiding oil hole.
- 4) Install bearing cap as previously outlined and evenly torque cap bolts to specified torque. Bearing cap **MUST** be torqued to specification in order to assure proper reading.

**NOTICE:**

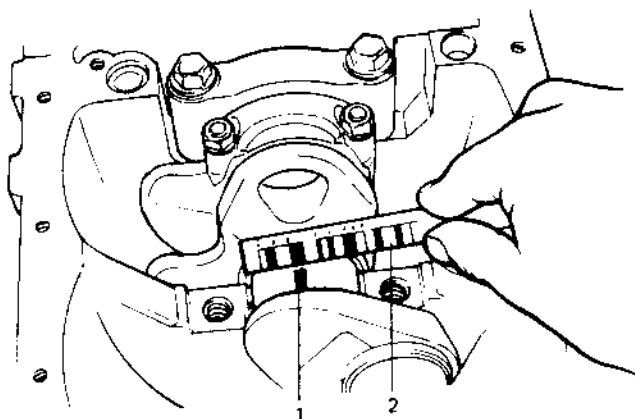
**Do not rotate crankshaft while gaging plastic is installed.**

- 5) Remove cap, and using scale on gaging plastic envelop, measure gaging plastic width at its widest point. If clearance exceeds its limit, replace bearing. Always replace both upper and lower inserts as a unit.

A new standard bearing may produce proper clearance. If not, it will be necessary to regrind crankshaft journal for use of 0.25 mm undersize bearing.

After selecting new bearing, recheck clearance.

	Standard	Limit
Bearing clearance	0.020 – 0.040 mm (0.0008 – 0.0016 in.)	0.060 mm (0.0023 in.)



1. Gaging plastic
2. Scale

Fig. 3-5-44 Measuring main bearing clearance

**Selection of main bearings:****STANDARD BEARING:**

If bearing is in malcondition, or bearing clearance is out of specification, select a new standard bearing according to the following procedure and install it.

- 1) First check journal diameter as follows.

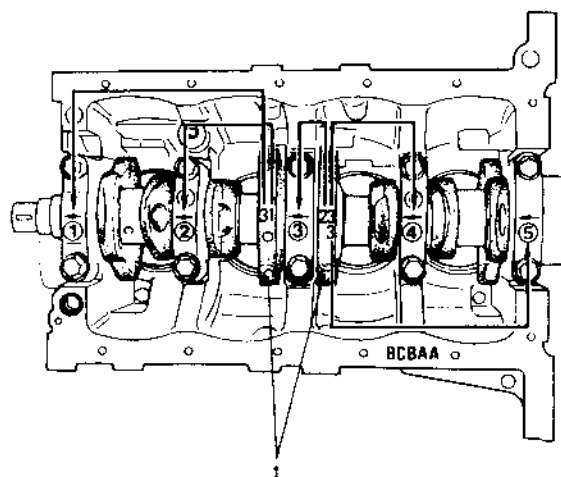
As shown in Fig. 3-5-45, crank webs of No. 2 and No. 3 cylinders have five stamped numerals.

Three kinds of numerals (1, 2 and 3) represent following journal diameters respectively.

Numeral stamped	Journal diameter
1	44.994 – 45.000 mm (1.7714 – 1.7716 in.)
2	44.988 – 44.994 mm (1.7712 – 1.7714 in.)
3	44.982 – 44.988 mm (1.7710 – 1.7712 in.)

The first, second, third, fourth and fifth (left to right) stamped numerals indicate the journal diameters at bearing caps "1", "2", "3", "4" and "5" respectively.

For example, in Fig. 3-5-45, the first (leftmost) numeral "3" indicates that journal dia. at bearing cap ① is within 44.982 – 44.988 mm, and second one "1" indicates that journal dia. at cap ② is within 44.994 – 45.000 mm.



1. Crank webs of No. 2 and 3 cylinder

Fig. 3-5-45 Stamped numerals on crank webs of No. 2 and No. 3 cylinders

2) Next, check bearing cap bore diameter without bearing.

On mating surface of cylinder block, five alphabets are stamped as shown in Fig. 3-5-46.

Three kinds of alphabets ("A", "B" and "C") represent following cap bore diameters.

Alphabet stamped	Bearing cap bore diameter (without bearing)
A	49.000 – 49.006 mm (1.9292 – 1.9294 in.)
B	49.006 – 49.012 mm (1.9294 – 1.9296 in.)
C	49.012 – 49.018 mm (1.9296 – 1.9298 in.)

The first, second, third, fourth and fifth (left to right) stamped alphabets indicate the cap bore diameter of bearing caps "1", "2", "3", "4" and "5" respectively.

For example, in Fig. 3-5-46, the first (leftmost) alphabet "B" indicates that the cap bore dia. of bearing cap ① is within 49.006 – 49.012 mm, and the fifth (rightmost) alphabet "A" indicates that the cap bore dia. of cap ⑤ is within 49.000 – 49.006 mm.

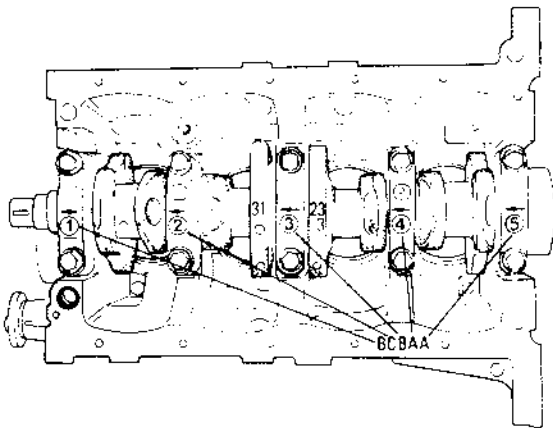
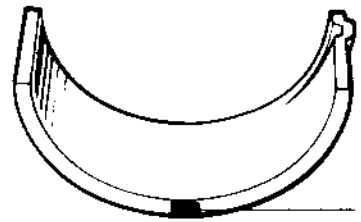


Fig. 3-5-46 Stamped alphabets on cylinder block

3) There are five kinds of standard bearings differing in thickness. To distinguish them, they are painted in following colors at the position indicated in Fig. 3-5-47. Each color indicates the following thicknesses at center of bearing.

Color painted	Bearing thickness
Green	1.996 – 2.000 mm (0.0786 – 0.0787 in.)
Black	1.999 – 2.003 mm (0.0787 – 0.0788 in.)
Colorless (no paint)	2.002 – 2.006 mm (0.0788 – 0.0789 in.)
Yellow	2.005 – 2.009 mm (0.0789 – 0.0790 in.)
Blue	2.008 – 2.012 mm (0.0790 – 0.0791 in.)



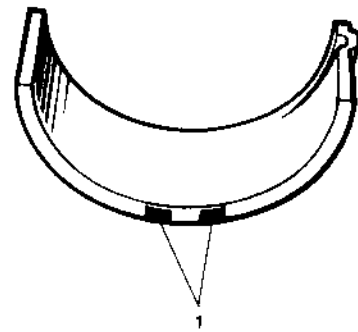
1. Paint

Fig. 3-5-47 Paint on standard bearing

4) From the numeral stamped on crank webs of No. 2 and No. 3 cylinders and the alphabets stamped on mating surface of cylinder block, determine new standard bearing to be installed to the journal, by referring to the table shown below.

For example, if numeral stamped on crank web is "1" and alphabet stamped on mating surface is "B", install new standard bearing painted in "Black" to its journal.

		Numerals stamped on crank webs (Journals diameter)		
		1	2	3
Alphabets stamped on mating surface	A	Green	Black	Colorless
	B	Black	Colorless	Yellow
	C	Colorless	Yellow	Blue
New standard bearing to be installed.				



1. Paint

Fig. 3-5-48 Paints on undersize bearing

- 5) Using gaging plastic, check bearing clearance with new standard bearing selected.  
If clearance still exceeds its limit, use next thicker bearing and recheck clearance.
- 6) When replacing crankshaft or cylinder block due to any reason, select new standard bearings to be installed by referring to the numerals stamped on new crankshaft or the alphabets stamped on the mating surface of new cylinder block.

#### UNDERSIZE BEARING (0.25 mm):

- 0.25 mm undersize bearing is available in 5 kinds differing in thickness.  
To distinguish them, each bearing is painted in following colors at position indicated in Fig. 3-5-48.  
Each color indicates following thickness at center of bearing.

Color painted	Bearing thickness
Green & Red	2.121 – 2.125 mm (0.0835 – 0.0836 in.)
Black & Red	2.124 – 2.128 mm (0.0836 – 0.0837 in.)
Red only	2.127 – 2.131 mm (0.0837 – 0.0838 in.)
Yellow & Red	2.130 – 2.134 mm (0.0838 – 0.0839 in.)
Blue & Red	2.133 – 2.137 mm (0.0839 – 0.0840 in.)

- If crankshaft journal is necessary to be reground to undersize, regrind the journal and select undersize bearing to be used as follows.

- 1) Regrind journal to following finished diameter.

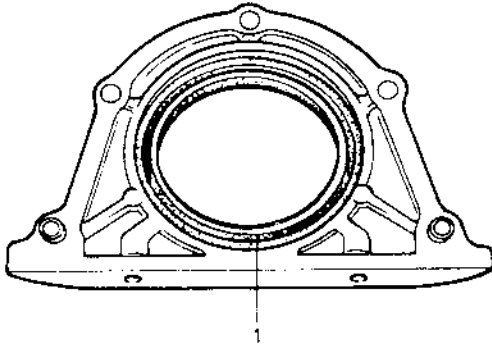
Finished diameter	44.732 – 44.750 mm (1.7612 – 1.7618 in.)
-------------------	---

- 2) Using micrometer, measure reground journal diameter. Measurement should be carried out in two directions perpendicular to each other in order to check for out-of-round.
- 3) From the journal diameter measured above and the alphabets stamped on mating surface of cylinder block, select the undersize bearing to be installed by referring to the table shown below.  
Check bearing clearance with undersize bearing selected.

		Measured journal diameter		
		44.744 – 44.750 mm (1.7616 – 1.7618 in.)	44.738 – 44.744 mm (1.7614 – 1.7616 in.)	44.732 – 44.738 mm (1.7612 – 1.7614 in.)
Alphabets stamped on mating surface of cylinder block	A	Green & Red	Black & Red	Red only
	B	Black & Red	Red only	Yellow & Red
	C	Red only	Yellow & Red	Blue & Red
Undersize bearing to be installed.				

### Rear Oil Seal

Carefully inspect oil seal for wear or damage. If its lip is worn or damaged, replace oil seal.



1. Rear oil seal

Fig. 3-5-49 Rear oil seal

### Flywheel

- If ring gear is damaged, cracked or worn, replace flywheel.
- If surface contacting clutch disc is damaged, or excessively worn, replace flywheel.
- Check flywheel for face runout with a dial gauge.  
If runout is out of limit, replace flywheel.

Limit on runout	0.2 mm (0.0078 in.)
-----------------	---------------------

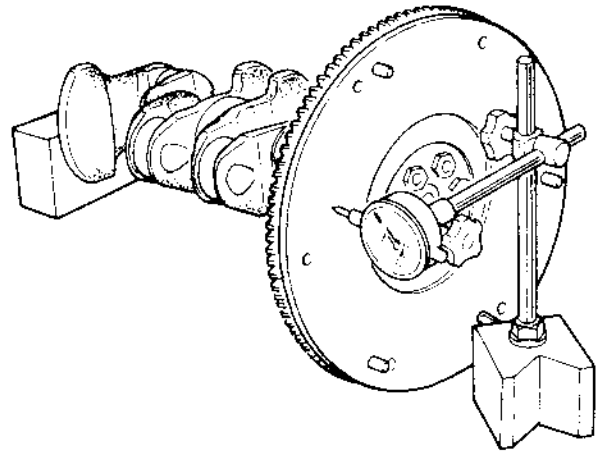


Fig. 3-5-50 Measuring runout

### Oil Pump

- 1) Inspect oil seal lip for fault or other damage. Replace as necessary.
  - 2) Inspect outer and inner rotors, rotor plate, and oil pump case for excessive wear or damage.
- Radial clearance:  
Check radial clearance between outer rotor and case, using thickness gauge.  
If clearance exceeds its limit, replace outer rotor or case.

Radial clearance between:	Limit on radial clearance
Outer rotor and case	0.310 mm (0.0122 in.)



### 3-6. ENGINE REASSEMBLY

#### NOTICE:

- All parts to be used in reassembly must be perfectly clean.
- Oil sliding and rubbing surfaces of engine parts just before using them in reassembly. Use engine oil (Refer to page 1-8).
- Have liquid packing ready for use. SUZUKI BOND NO. 1215 is specified for it. Use it wherever its use is specified in order to ensure leak-free (oil and water) workmanship of reassembly.
- There are many running clearances. During the course of engine reassembly, be sure to check these clearances, one after another, as they form.
- Gaskets, "O" rings and similar sealing members must be in perfect condition. For these members, use replacement parts in stock.
- Tightening torque is specified for important fasteners — mainly bolts and nuts — of the engine and other components. Use torque wrenches and constantly refer to the specified values given on p. 3-58.
- Do not disregard match marks provided on parts. Some of them are those given at the time of disassembly.
- There are many sets of parts. Crankshaft bearings, connecting rods, pistons, etc., are in combination sets. Do not disturb such combinations and make sure that each part goes back to where it came from.

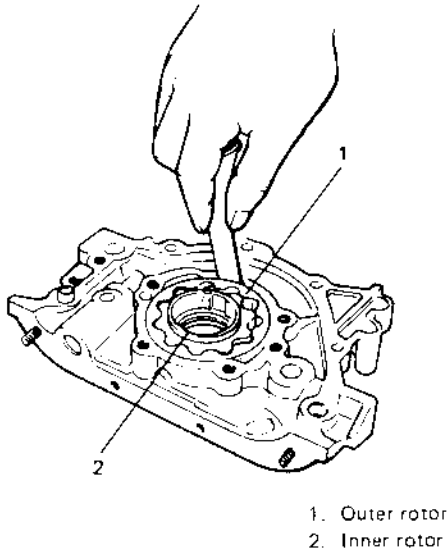


Fig. 3-5-51 Radial clearances

- Side clearance:  
Using straight edge and thickness gauge, measure side clearance.

Limit on side clearance	0.15 mm (0.0059 in.)
-------------------------	----------------------

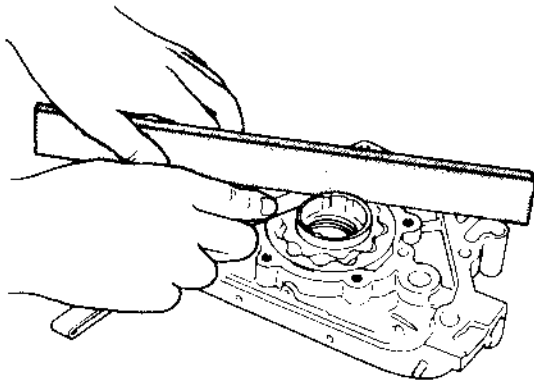


Fig. 3-5-52 Side clearance measurement

#### Timing Belt and Tensioner

- Inspect timing belt for wear or crack. Replace it as necessary.
- Inspect tensioner for smooth rotation.

Engine reassembly is the reverse of engine disassembly as far as sequence is concerned, but there are many reassembling steps that involve measures necessary for restoring engine as close to factory-assembled condition as possible. Only those steps will be dealt with here.

## Crankshaft

1) Install main bearings to cylinder block.

### NOTICE:

If main bearing replacement is necessary, select such bearing as to allow proper clearance as described on p. 3-30 and install it in place.

Between two halves of main bearing, one side has oil groove. Install this half with oil groove to cylinder block, and another half without oil groove to bearing cap.

Make sure that two halves are painted with same color.

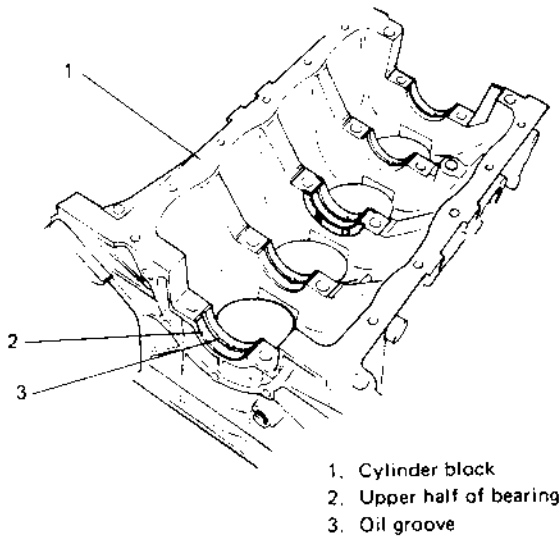


Fig. 3-6-1 Installing bearing half with oil groove

2) Be sure to oil crankshaft journal bearings as shown.

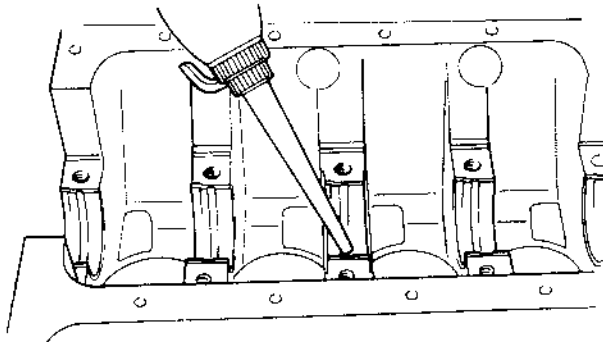


Fig. 3-6-2

3) Install thrust bearings to cylinder block between No. 2 and No. 3 cylinders. Face oil groove sides to crank webs.

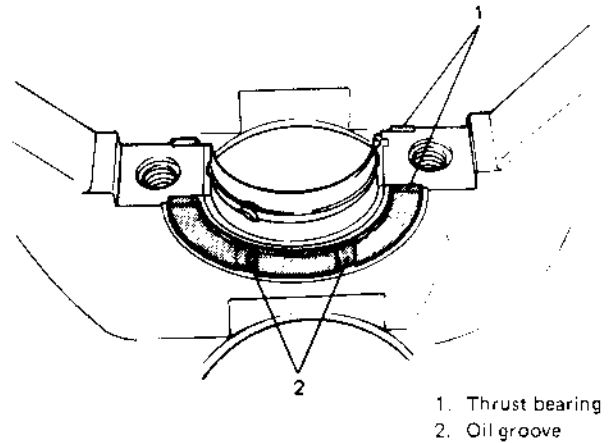


Fig. 3-6-3 Installing thrust bearing

4) Install crankshaft to cylinder block.

5) Oil crankshaft journals.

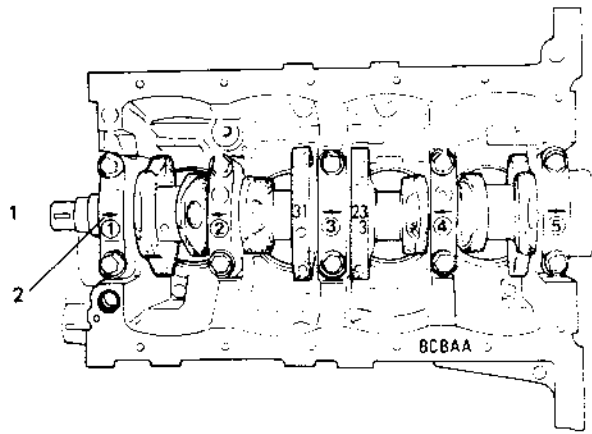
6) When fitting bearing caps to journals after setting crankshaft in place, be sure to point arrow mark (on each cap) to crankshaft pulley side. Fit them sequentially in ascending order, 1, 2, 3, 4 and 5, starting from pulley side.

Tightening torque for main bearing cap bolts	50 – 57 N·m 5.0 – 5.7 kg·m 36.5 – 41.0 lb·ft
--	--

Gradual and uniform tightening is important for bearing cap bolts. Make sure that five caps become tight equally and uniformly specified torque.

### NOTICE:

After tightening cap bolts, check to be sure that crankshaft rotates smoothly when turned by hand.



1. Crankshaft pulley side
2. Arrow mark

Fig. 3-6-4 Installing main bearing caps

### Oil Seal Housing

Install oil seal housing and its gasket. Install new gasket. Do not reuse gasket removed in disassembly. Apply oil to oil seal lip before installing. Tighten housing bolts to specification.

After installing oil seal housing, gasket edges might bulge out; if so, cut off edges to flush with cylinder block and oil seal housing.

Tightening torque for housing bolts	10 – 13 N·m
	1.0 – 1.3 kg·m
	7.5 – 9.0 lb·ft

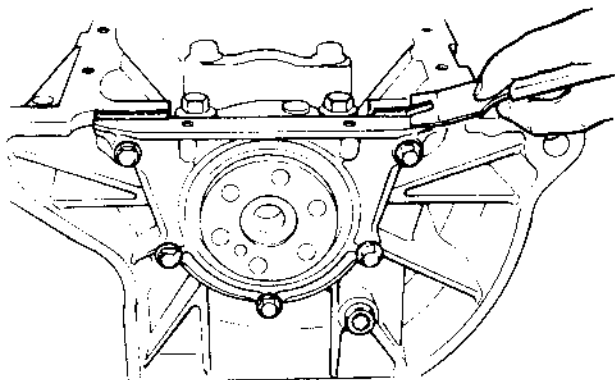


Fig. 3-6-5 Cutting off edges of gasket

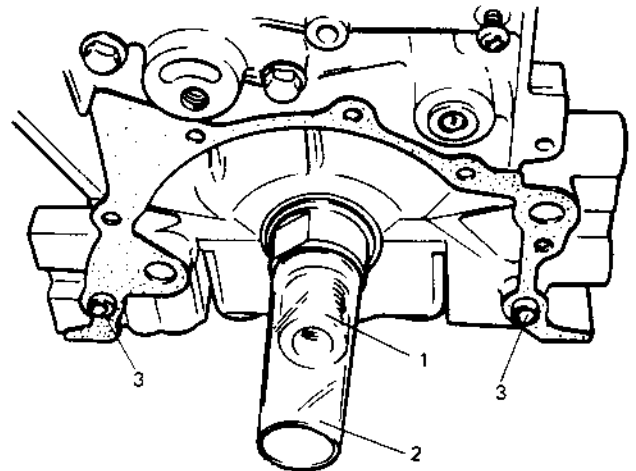
### Oil Pump

#### NOTICE:

Reassemble components of oil pump assembly according to following procedure, if disassembled.

- a) Wash, clean and then dry all disassembled parts.
- b) Apply thin coat of engine oil to inner and outer rotors, oil seal lip portion, and inside surfaces of oil pump case and plate.
- c) Install outer and inner rotors to pump case.
- d) Install gear plate. Tighten 5 screws securely.
- e) After installing plate, check to be sure that gears turn smoothly by hand.

- 1) Install two oil pump pins and oil pump gasket to cylinder block. Use new gasket.
- 2) To prevent oil seal lip from being damaged or upturned when installing oil pump to crankshaft, fit oil seal guide (special tool) to crankshaft, and apply engine oil to it.



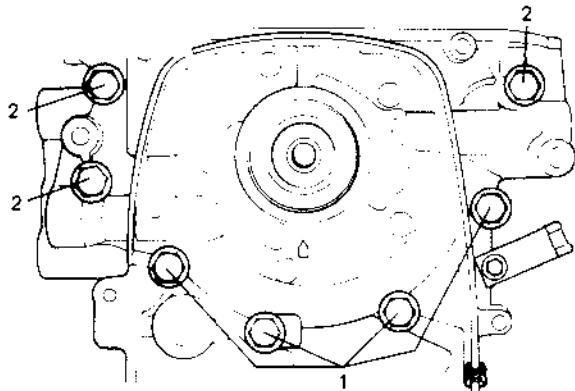
1. Crankshaft
2. Oil seal guide (Vinyl resin) (Special tool 09926-18210)
3. Oil pump pin

Fig. 3-6-6 Special tool (Oil seal guide) installation

3) Install oil pump to crankshaft and cylinder block. Install No. 1 and No. 2 bolts as shown in Fig. 3-6-7, and tighten them to specified torque.

After installing oil pump, check to be sure that oil seal lip is not upturned, and then remove special tool.

Tightening torque for No. 1 and No. 2 bolts	9 – 12 N·m 0.9 – 1.2 kg·m 7.0 – 8.5 lb·ft
---	---



- 1. No. 1 bolts (short)
- 2. No. 2 bolts (long)

Fig. 3-6-7

4) Edge of oil pump gasket might bulge out: if it does, cut bulge off with a sharp knife, making edge smooth and flush with end faces of the pump case and cylinder block.

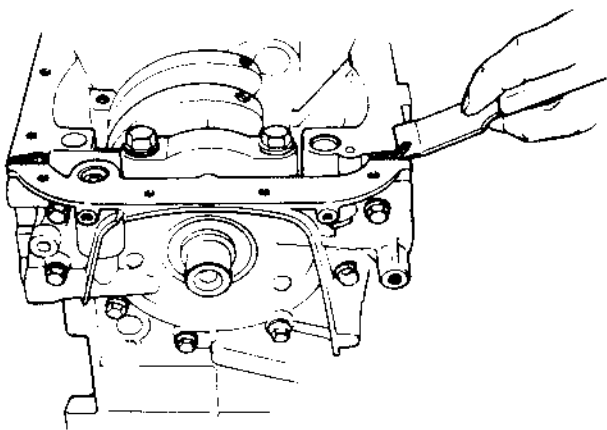


Fig. 3-6-8 Cutting the edge of gasket

### Piston, Connecting Rod and Piston Rings

#### NOTICE:

Two sizes of piston are available as standard size spare part so as to ensure proper piston-to-cylinder clearance. When installing a standard size piston, make sure to match piston with cylinder as follows.

a) Each piston has a stamped number 1 or 2 as shown depending on its outer diameter.

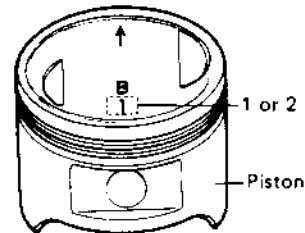


Fig. 3-6-9

b) There are also stamped numbers of 1 and 2 on cylinder block as shown below. First number indicates inner diameter of No. 1 cylinder, second number of No. 2 cylinder, third number of No. 3 cylinder and fourth number of No. 4 cylinder.

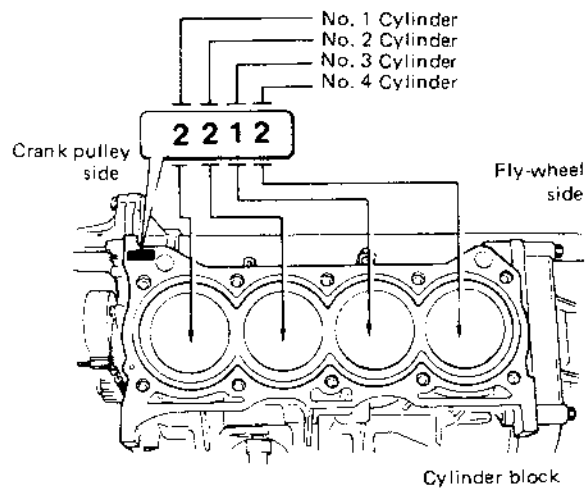


Fig. 3-6-10

c) Use a number 2 stamped piston for installation if cylinder is identified with number 2 and a number 1 piston for cylinder with number 1.

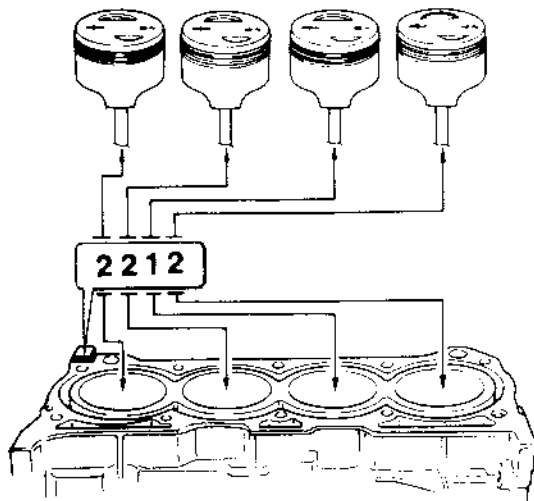


Fig. 3-6-11

Number at the top (mark)	Piston		Cylinder		Piston-to-cylinder clearance
	Outside diameter	Number (mark)	Bore diameter	Number (mark)	
1	73.98 - 73.99mm (2.9126 - 2.9130in.)	1	74.01 - 74.02mm (2.9138 - 2.9142in.)	1	0.02 - 0.04mm (0.0008 - 0.0015in.)
2	73.97 - 73.98mm (2.9122 - 2.9126in.)	2	74.00 - 74.01mm (2.9134 - 2.9138in.)	2	0.02 - 0.04mm (0.0008 - 0.0015in.)

Also, a letter A, B, C etc., is stamped on piston head but ordinarily it is not necessary to discriminate each piston by this number.

1) Install connecting rod to piston.

① After applying engine oil to piston pin holes in piston and connecting rod, fit connecting rod to piston as prescribed in Fig. 3-6-12.

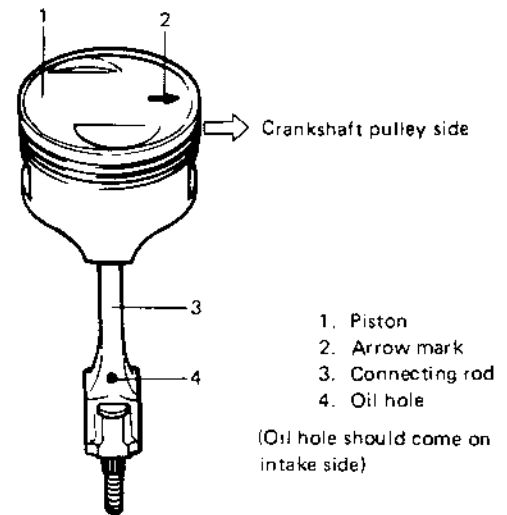


Fig. 3-6-12 Fitting connecting rod to piston

② Place piston on piston pin remover and installer (special tool) as indicated in Fig. 3-6-13, and press piston pin into piston and connecting rod (Fig. 3-6-14).

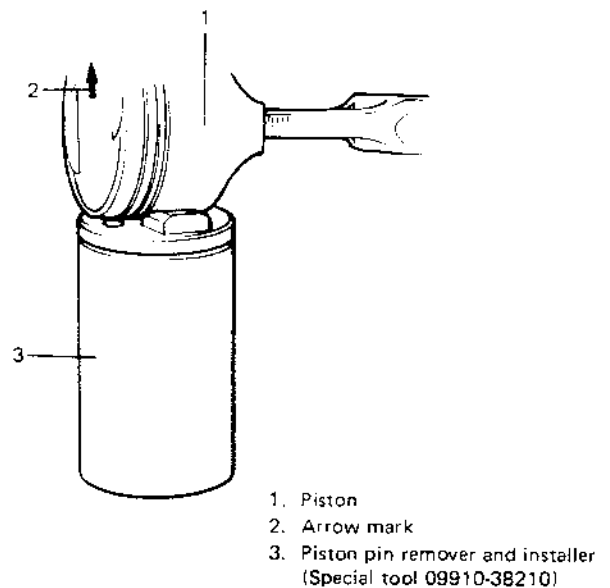


Fig. 3-6-13 Fitting piston to special tool

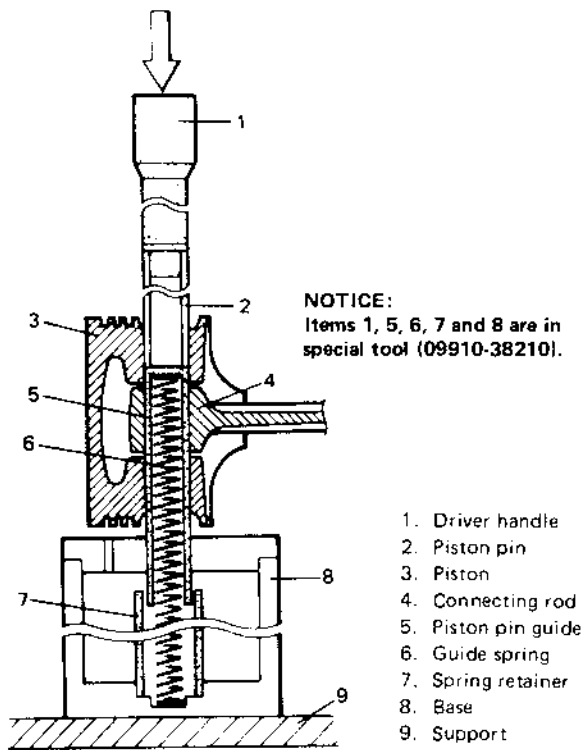


Fig. 3-6-14 Installing piston pin

- ③ Press piston pin until line marked on driver handle is flush with flat surface of piston (Fig. 3-6-15).

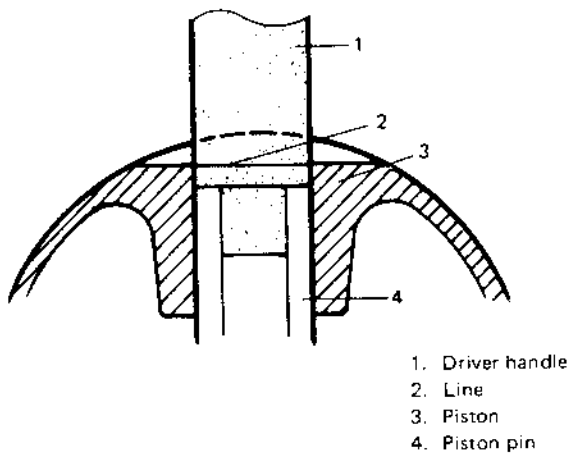


Fig. 3-6-15 Line marked on driver handle

- 2) Install piston rings to piston.
- As indicated in Fig. 3-6-16, 1st and 2nd rings have "R" or "T" mark. Installing these piston rings to piston with marked side of each ring faced forward top of piston.
  - 1st ring differs from 2nd ring in thickness, shape and color of the surface contacting cylinder wall.
- Distinguish 1st ring from 2nd ring by referring to Fig. 3-6-16.
- When installing oil ring, install spacer first and then two rails.

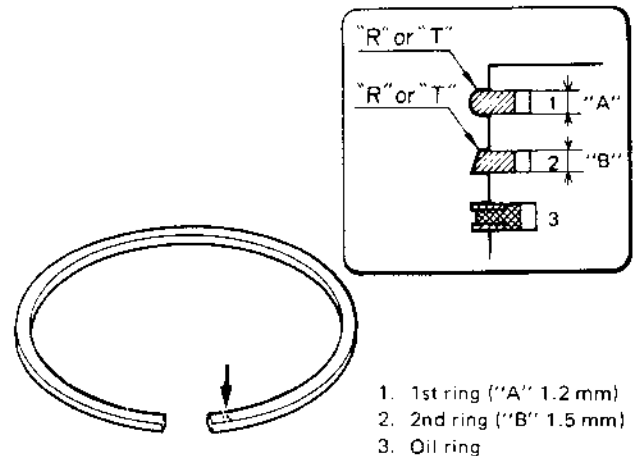


Fig. 3-6-16 Piston rings installation

- After installing 3 rings (1st, 2nd and oil rings), distribute their end gaps as shown in Fig. 3-6-17.

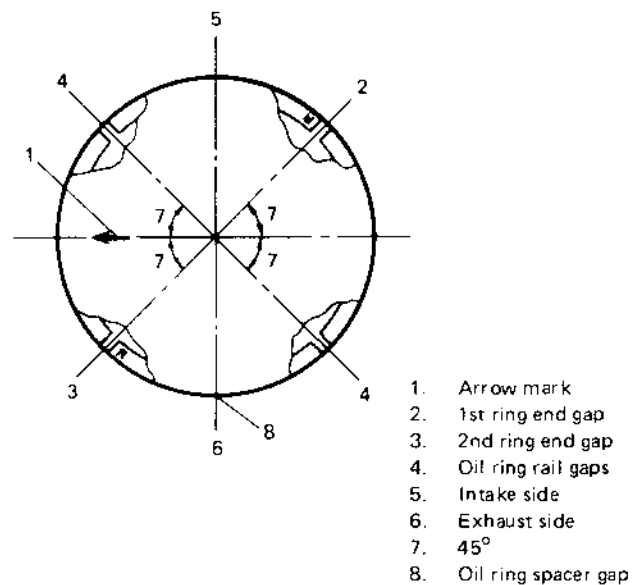


Fig. 3-6-17 Piston ring end gaps positions

- 3) Install piston and connecting rod assembly into cylinder bore.
- ① Apply engine oil to pistons, rings, cylinder walls, connecting rod bearings and crankpins.
  - ② Put guide hoses over connecting rod bolts as shown in Fig. 3-6-18. These guide hoses protect crankpin and thread of rod bolt from damage during installation of connecting rod and piston assembly.

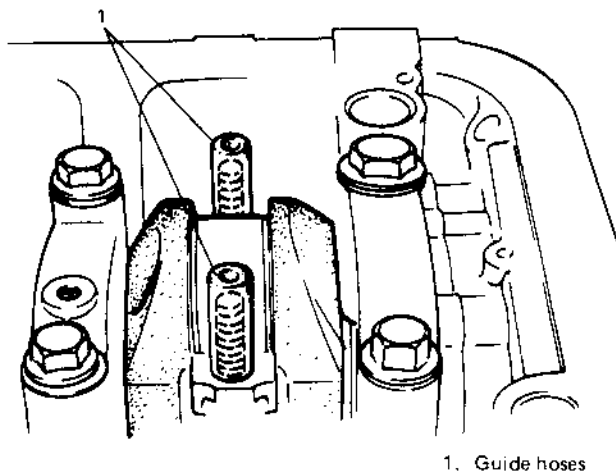


Fig. 3-6-18 Guide hoses installation

- ③ When installing piston and connecting rod assembly into cylinder bore, point arrow mark on each piston head to crankshaft pulley side.

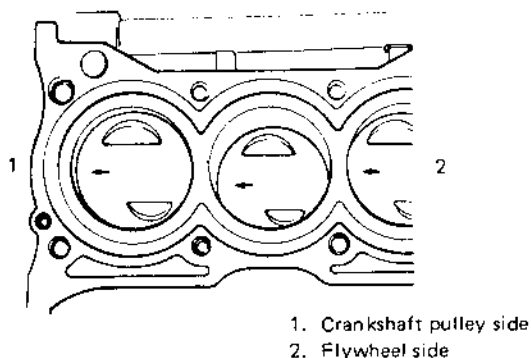


Fig. 3-6-19 Direction of arrow mark on piston head

- ④ Use piston ring compressor (Special tool) to compress rings. Guide connecting rod into place on the crankshaft. Using a hammer handle, tap piston head to install piston into bore. Hold ring compressor firmly against cylinder block until all piston rings have entered cylinder bore.

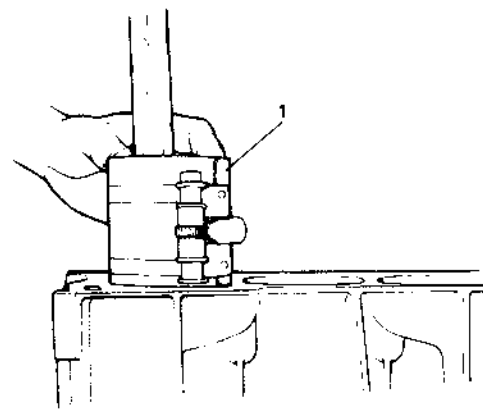


Fig. 3-6-20 Installing piston to cylinder

- 4) Install connecting rod bearing cap. When installing cap to rod, point arrow mark on cap to crankshaft pulley side. Tighten cap nuts to specification.

Tightening torque for rod bearing cap nuts	33 – 37 N·m 3.3 – 3.7 kg·m 24.0 – 26.5 lb·ft
--	--

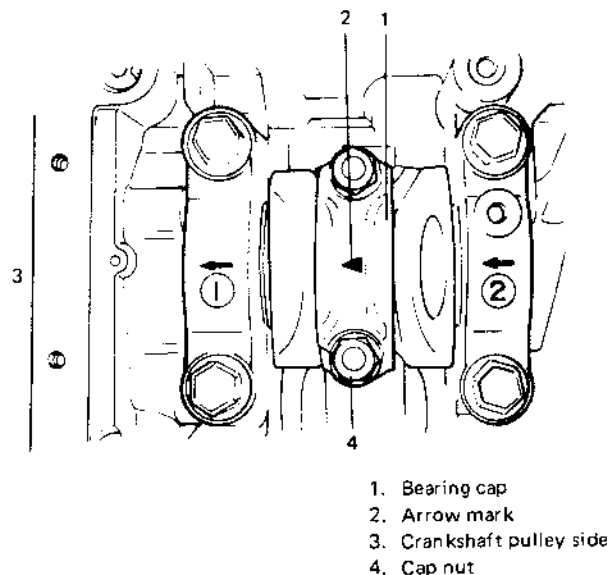


Fig. 3-6-21 Installing bearing cap

### Oil Pump Strainer

Install seal in the position shown in Fig. 3-6-22. Tighten strainer bolt first and bracket bolt to specified torque.

Tightening torque for bolts	9 – 12 N·m
	0.9 – 1.2 kg·m
	6.5 – 8.5 lb·ft

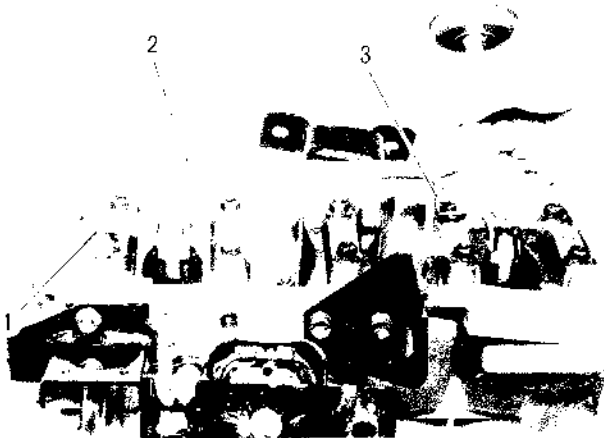


Fig. 3-6-22 Installing seal

- 1. Seal
- 2. Strainer
- 3. Bracket

### Oil Pan

1) Clean mating surfaces of oil pan and cylinder block. Remove oil, old sealant, and dusts from mating surfaces.

After cleaning, apply silicon type sealant to oil pan mating surface continuously as shown in Fig. 3-6-23.



Sealant (99000-31150)

Fig. 3-6-23 Applying sealant to oil pan

2) Install oil pan to cylinder block.

After fitting oil pan to block, run in securing bolts and start tightening at the center: move wrench outward, tightening one bolt at a time.

Tighten bolts to specified torque.

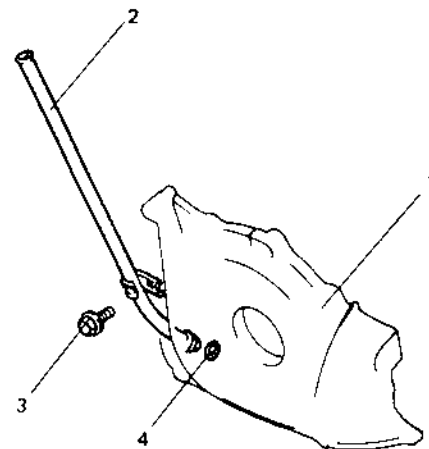
Tightening torque for oil pan bolts	9 – 12 N·m
	0.9 – 1.2 kg·m
	7.0 – 8.5 lb·ft

3) Install gasket and drain plug to oil pan.

Tighten drain plug to specified torque.

Tightening torque for drain plug	30 – 40 N·m
	3.0 – 4.0 kg·m
	22.0 – 28.5 lb·ft

4) Install guide seal to pump case and then oil level gauge guide.



- 1. Oil pump
- 2. Oil level gauge guide
- 3. Guide bolt
- 4. Guide seal

Fig. 3-6-24 Oil level gauge guide

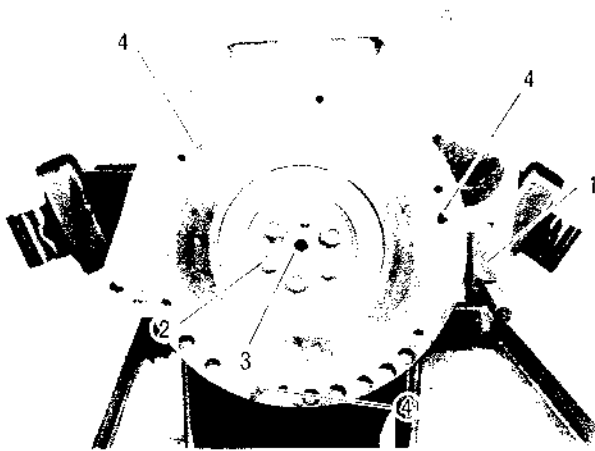
### Flywheel

Install flywheel to crankshaft.

Using special tool, lock flywheel, and tighten flywheel bolts to specification.

Tightening torque for flywheel bolts	57 – 65 N·m
	5.7 – 6.5 kg·m
	41.5 – 47 lb·ft





1. Flywheel holder (Special tool 09924-17810)
2. Flywheel bolts
3. Input shaft end bearing
4. Locating pin

Fig. 3-6-25

### Cylinder Head

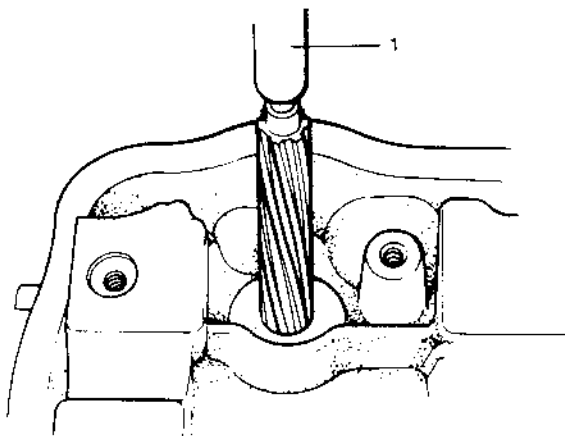
#### NOTICE:

- Do not reuse valve guide once disassembled. Install new valve guide (Oversize).
- Intake and exhaust valve guides are identical.

Valve guide oversize	0.03 mm (0.0012 in.)
Valve guide protrusion (In and Ex)	14 mm (0.55 in.)

- 1) Install new valve guide into cylinder head.
  - a) Before installing new valve guide into cylinder head, ream guide hole with 12 mm reamer (Special tool) to remove burrs, making sure that guide hole diameter after reaming comes within specified range.

Valve guide hole Dia. (In & Ex)	12.030 – 12.048 mm (0.4736 – 0.4743 in.)
---------------------------------	---



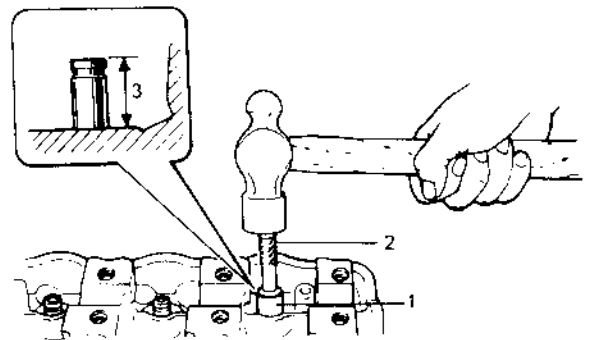
1. 12 mm reamer (Special tool 09916-37310)

Fig. 3-6-26 Reaming guide hole

- b) Install valve guide to cylinder head.

Heat cylinder head uniformly at a temperature of 80 to 100°C (176 to 212°F), using care not to distort head, and drive new valve guide into hole with special tools. Refer to Fig. 3-6-27.

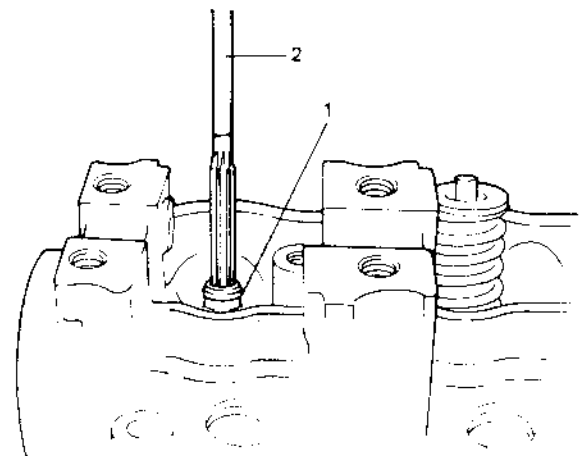
Drive in new valve guide until valve guide installer (Special tool) contacts cylinder head. After installation, make sure that valve guide protrudes by 14 mm from cylinder head (Fig. 3-6-27).



1. Valve guide installer attachment (Special tool 09917-88210)
2. Valve guide installer handle (Special tool 09916-57321)
3. Valve guide protrusion (14 mm)

Fig. 3-6-27 Valve guide installation

- c) Ream valve guide bore with 7 mm reamer (Special tool).  
After reaming, clean bore.



1. Valve guide
2. 7 mm reamer (Special tool 09916-34520)

Fig. 3-6-28 Reaming valve guide bore

- 2) Install valve spring seat to cylinder head.
- 3) Install new valve stem seal to valve guide.  
After applying engine oil to seal and spindle of valve stem seal installer (special tool), fit oil seal to spindle, and then install seal to valve guide by pushing special tool by hand.  
After installation, check to be sure that seal is properly fixed to valve guide.

**NOTICE:**

- Do not reuse oil seal disassembled. Be sure to install new oil seal.
- When installing, never tap or hit special tool with a hammer or else. Install seal to guide only by pushing special tool with hand. Tapping or hitting special tool may cause damage on seal.

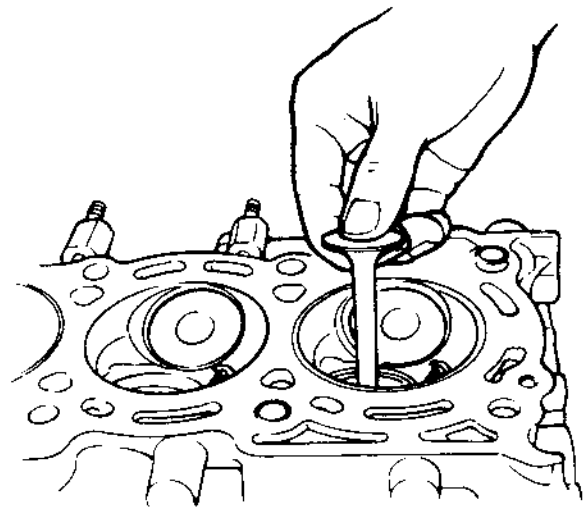
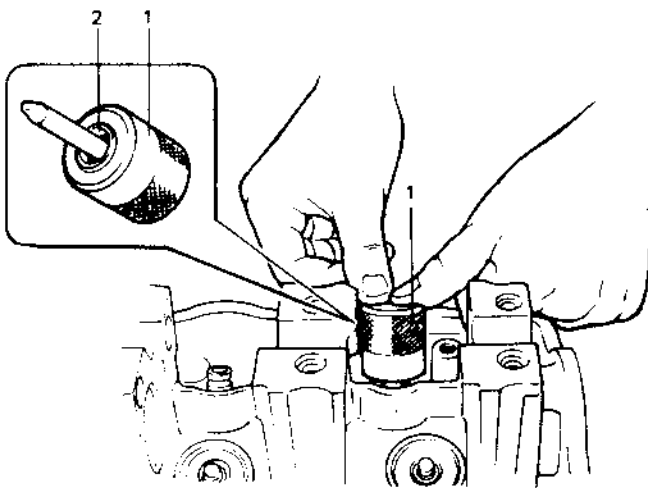


Fig. 3-6-30 Valve installation



1. Valve stem seal installer (Special tool 09917-98210)
2. Valve stem seal

Fig. 3-6-29 Valve stem seal installation

- 4) Install valve to valve guide.  
Before installing valve to valve guide, apply engine oil to stem seal, valve guide bore, and valve stem.

- 5) Install valve spring and spring retainer.  
Each valve spring has top end (large-pitch end) and bottom end (small-pitch end). Be sure to position spring in place with its bottom end (small-pitch end) down to valve spring seat side.

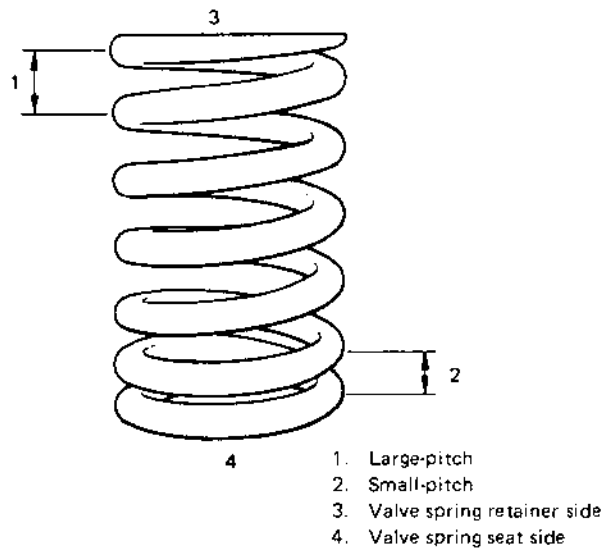
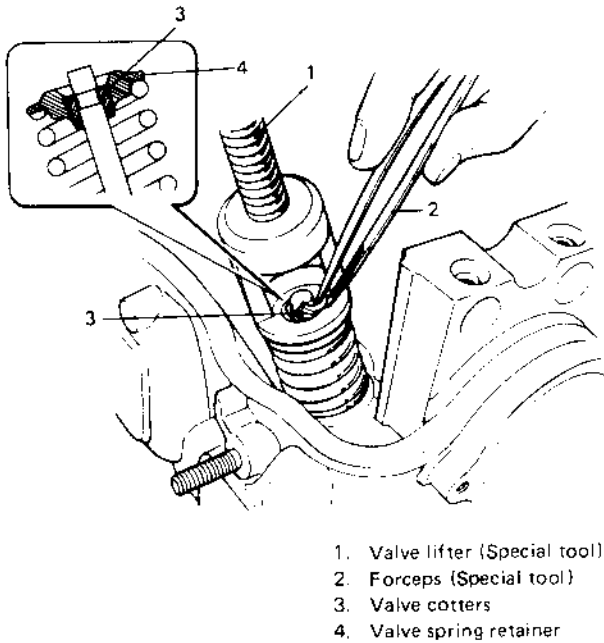


Fig. 3-6-31 Valve spring installation

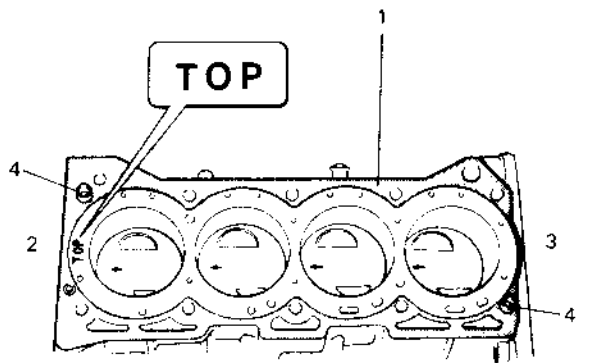
6) Using special tool (Valve lifter), compress valve spring and fit two valve cotters to groove provided in valve stem.



1. Valve lifter (Special tool)
2. Forceps (Special tool)
3. Valve cotters
4. Valve spring retainer

Fig. 3-6-32 Valve cotters installation

7) Be sure that locating pins (4) are in place and then install new head gasket as shown in Fig. 3-6-33, namely in such a way that "TOP" mark provided on the gasket comes on top side (toward cylinder head side) and on crankshaft pulley side.



1. Cylinder head gasket
2. Crankshaft pulley side
3. Flywheel side
4. Locating pin

Fig. 3-6-33 Cylinder head gasket installation

8) Install cylinder head onto cylinder block. Tighten cylinder head bolts gradually with a torque wrench, following sequence in Fig. 3-6-34. Finally tighten bolts to specified torque.

Tightening torque for cylinder head bolts	63 – 70 N·m
	6.3 – 7.0 kg·m
	46.0 – 50.5 lb·ft

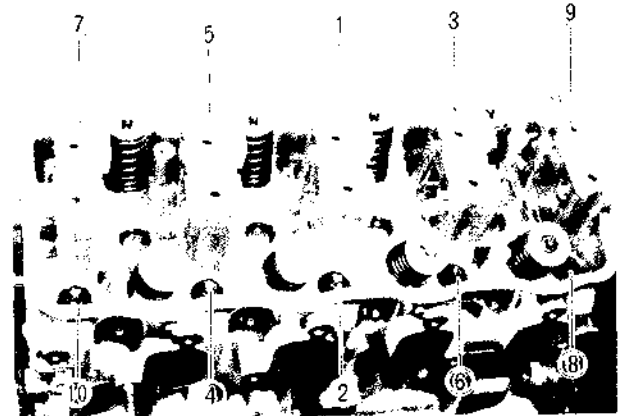


Fig. 3-6-34 Tightening sequence of cylinder head bolts

#### Camshaft

- 1) Apply engine oil to cams and journals on camshaft, and oil seal on cylinder head.
- 2) Install to cylinder head from transmission case side.

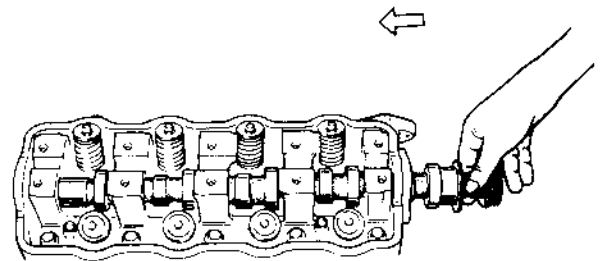


Fig. 3-6-35 Camshaft installation

## Rocker-Arm Shafts

- 1) Apply engine oil to rocker arms and rocker arm shafts.
- 2) Install rocker arms, springs and rocker arm shafts.

The two rocker arm shafts are not identical. To distinguish between the two, dimensions of their stepped ends differ as shown in Fig. 3-6-36. Install intake rocker arm shaft, facing its stepped end to camshaft pulley side, and exhaust rocker arm shaft, facing its stepped end to distributor side (rear side).

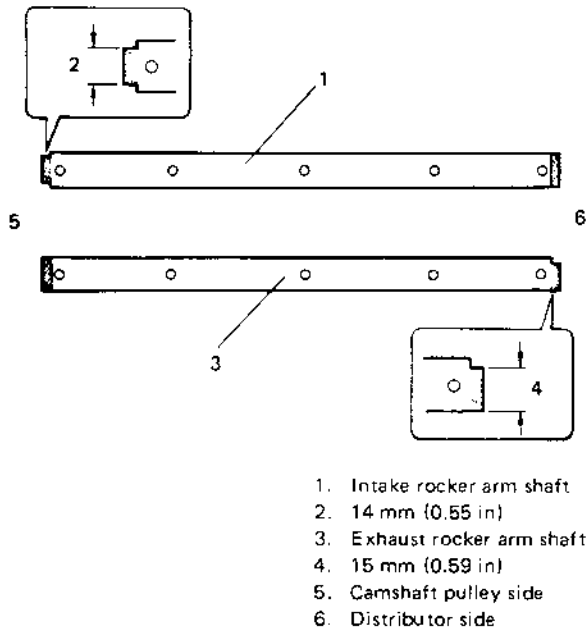


Fig. 3-6-36 Rocker arm shafts installation

- 3) After installing rocker arms, springs, and rocker arm shafts as shown in Fig. 3-6-37, tighten rocker arm shaft screws to specified torque.

Tightening torque for rocker arm shaft screws	9 – 12 N·m 0.9 – 1.2 kg·m 7.0 – 8.5 lb-ft
---	---

### NOTICE:

Valve clearance is adjusted after all parts are assembled. So it is not adjusted at this point. Leave rocker arm adjusting screw as loose as can be.

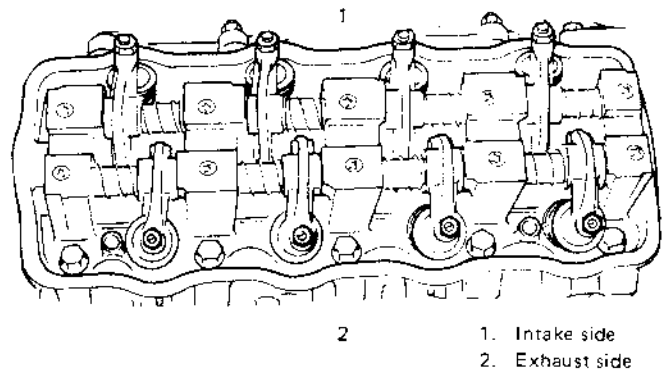


Fig. 3-6-37

## Water Inlet Pipe

Install water inlet pipe to cylinder block.

Make sure to fit seal ring ① (O-ring) to inlet pipe before installation.

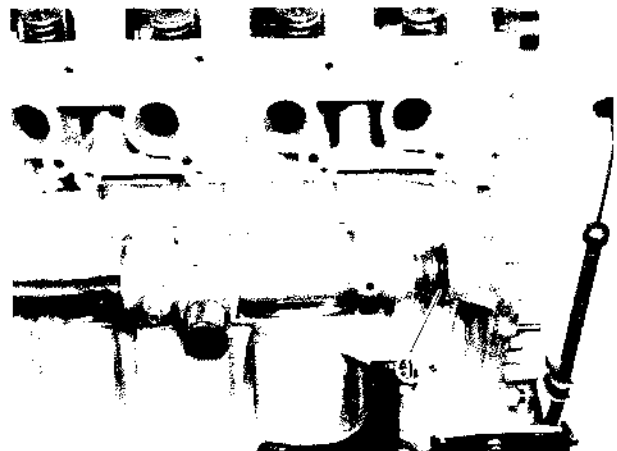


Fig. 3-6-38

## Intake Manifold and Carburetor

- 1) Install intake manifold gasket to cylinder head. Use new gasket.

### NOTICE:

Clean cylinder head mating surface with gasket before installation.

- 2) Install intake manifold with carburetor to cylinder head.
- 3) Tighten manifold bolts and nuts to specified torque.

Tightening torque for manifold bolts and nuts	N·m	kg·m	lb-ft
	18 – 28	1.8 – 2.8	13.5 – 20.0

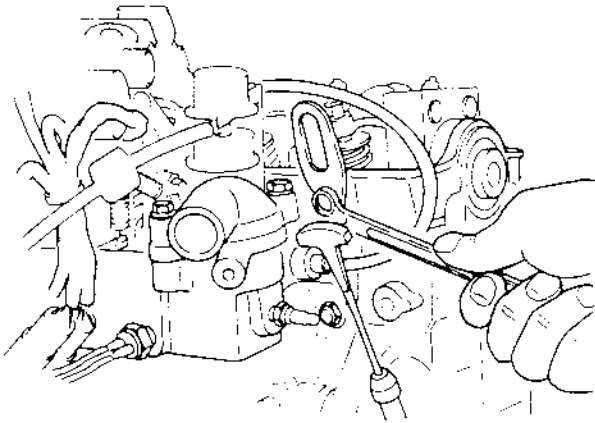


Fig. 3-6-39

- 4) Connect water hoses to water inlet pipe and clamp each hose.

#### Oil Filter

Install oil filter.

**CAUTION:**

For oil filter installation, refer to P. 1-7 of this manual.

#### Exhaust Manifold and Cover

- 1) Install exhaust manifold gasket to cylinder head.  
Use new gasket.

**NOTICE:**

Clean cylinder head mating surface with gasket before installation.

- 2) Install exhaust manifold to cylinder head.
- 3) Tighten bolts and nuts to specified torque.

Tightening torque for bolts and nuts	N·m	kg·m	lb·ft
	18 – 28	1.8 – 2.8	13.5 – 20.0

- 4) Install exhaust manifold cover.

#### Water pump

- 1) Install water pump gasket to cylinder block.  
Use new gasket.

**NOTICE:**

Clean cylinder block mating surface with gasket before installation.

- 2) Install water pump to cylinder block.
- 3) Tighten bolts and nuts to specified torque.

Tightening torque for water pump bolts and nuts	N·m	kg·m	lb·ft
	9 – 12	0.9 – 1.2	7.0 – 8.5



Fig. 3-6-40

- 4) Install rubber seats ①; one between oil pump and water pump and the other between water pump and cylinder head.



Fig. 3-6-41

**Timing Belt Inside Cover, Belt Pulleys, Tensioner, Timing Belt and Outside Cover**

1) Install timing belt inside cover to cylinder head.

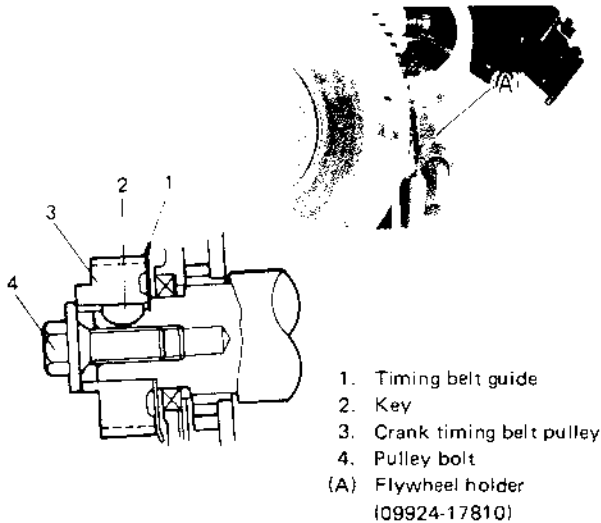
2) Install crankshaft timing belt guide, key and pulley.

Refer to Fig. 3-6-42 for proper installation of these parts.

Install timing belt guide in such a way that its concave side faces oil pump.

Tighten crankshaft timing belt pulley bolt to specified torque by using flywheel holder A (Special tool).

Tightening torque for timing belt pulley bolt	N·m	kg·m	lb·ft
	65 – 75	6.5 – 7.5	47.5–54.0

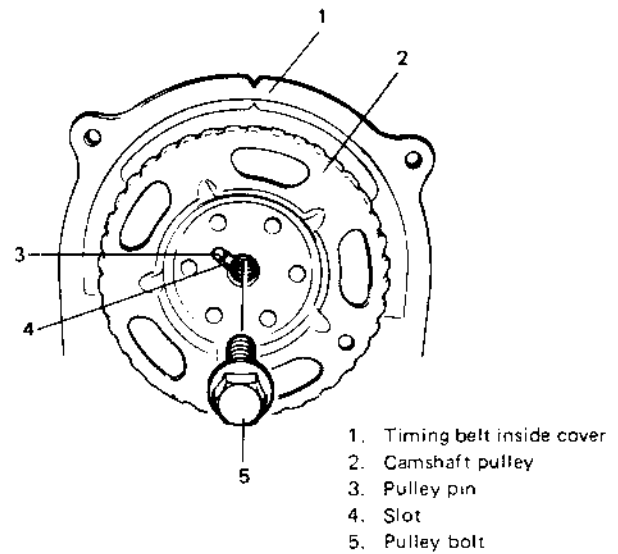


*Fig. 3-6-42 Installing guide, key and pulley*

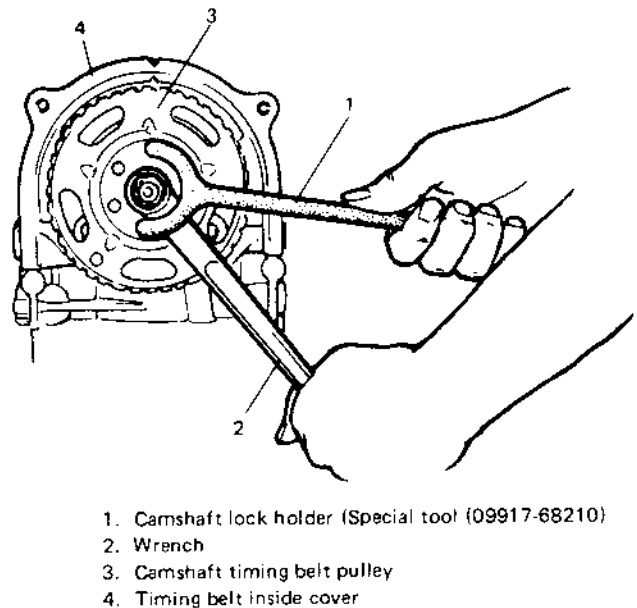
3) Install camshaft timing belt pulley.

Fit pulley pin on camshaft into slot in camshaft pulley. Tighten pulley bolt to specified torque with special tool (1) applied as shown in Fig. 3-6-44.

Tightening torque for pulley bolt	N·m	kg·m	lb·ft
	56 – 64	5.6 – 6.4	41.0–46.0



*Fig. 3-6-43 Pulley pin, slot and pulley bolt*



*Fig. 3-6-44*

- 4) Install timing belt tensioner plate to tensioner.  
Insert lug of tensioner plate into hole of tensioner.

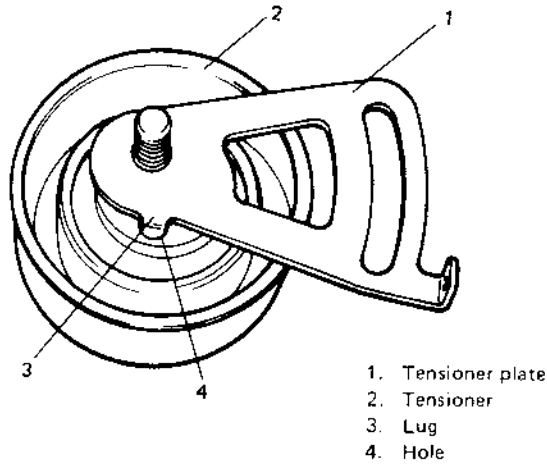


Fig. 3-6-45 Lug and hole

- 5) Install timing belt tensioner, tensioner plate and spring to cylinder block.  
Do not tighten tensioner bolt and stud with wrench yet.  
Hand tighten only at this time.  
Be sure that plate movement in arrow direction as shown in Fig. 3-6-46 causes the same directional movement of tensioner. If no associated movement between plate and tensioner occurs, remove tensioner and plate again and reinsert plate lug into tensioner hole.

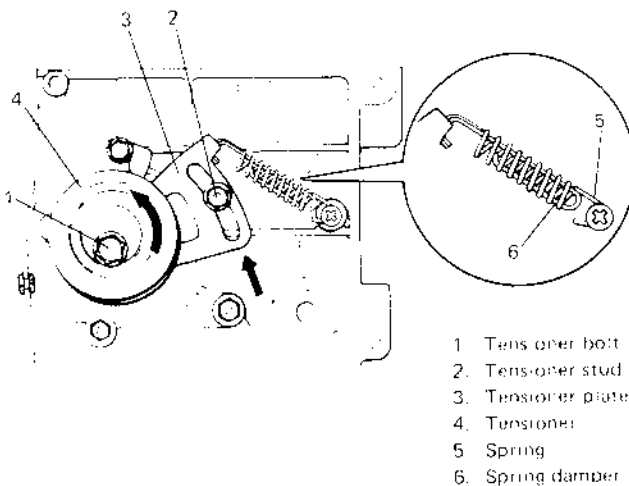


Fig. 3-6-46 Tensioner installation

- 6) Before installing timing belt to camshaft pulley and crankshaft timing belt pulley, loosen all valve adjusting screws of intake and exhaust rocker arms fully, or check to ensure they are loose.

This is to permit free rotation of camshaft for the following reason; when installing timing belt to both pulleys, belt should be correctly tensioned by tensioner spring force. If camshaft does not rotate freely, belt will not be correctly tensioned by tensioner.

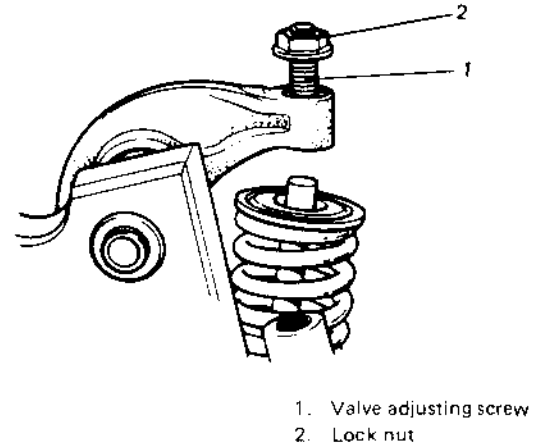


Fig. 3-6-47 Valve adjusting screw and lock nut

- 7) After loosening all valve adjusting screws all the way, turn camshaft pulley clockwise and align timing mark on camshaft pulley with "V" mark on belt inside cover as shown in Fig. 3-6-48.

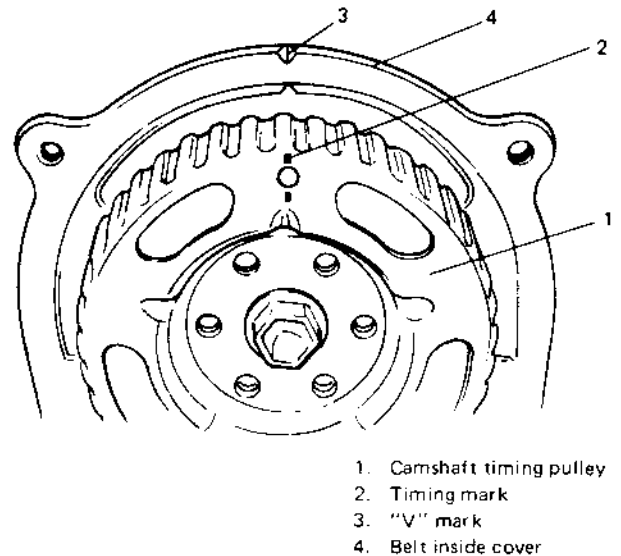


Fig. 3-6-48 Timing marks

8) Turn crankshaft clockwise, fitting 17 mm wrench to crankshaft timing belt pulley bolt, and align punch mark on timing belt pulley with arrow mark on oil pump as shown in Fig. 3-6-49.

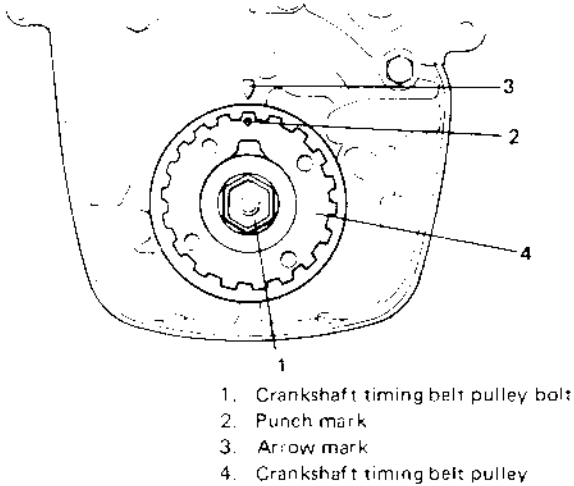


Fig. 3-6-49 Timing marks

9) With 4 marks aligned, install timing belt on two pulleys in such a way that drive side of belt is free from any slack, and with tensioner plate pushed up by finger.

**NOTICE:**

In this state, No.4 piston is at top dead center of compression stroke.

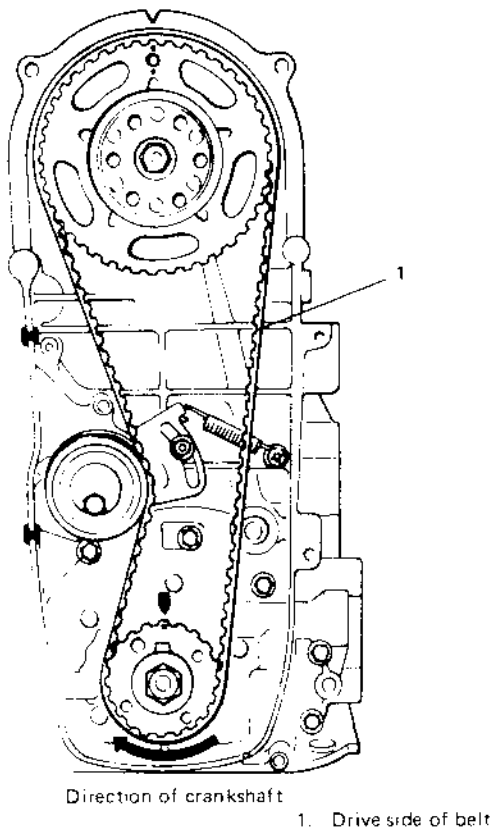


Fig. 3-6-50 Installing timing belt

**NOTICE:**

When installing timing belt, match arrow mark (⇒) on timing belt with rotating direction of crankshaft.

10) To allow belt to be free of any slack, turn crankshaft clockwise fully twice after installing belt. After removing belt slack, tighten tensioner stud first and then tensioner bolt to 24 – 30 N·m (2.4 – 3.0 kg·m, 17.5 – 21.5 lb·ft). Then confirm again that 4 marks are matched.

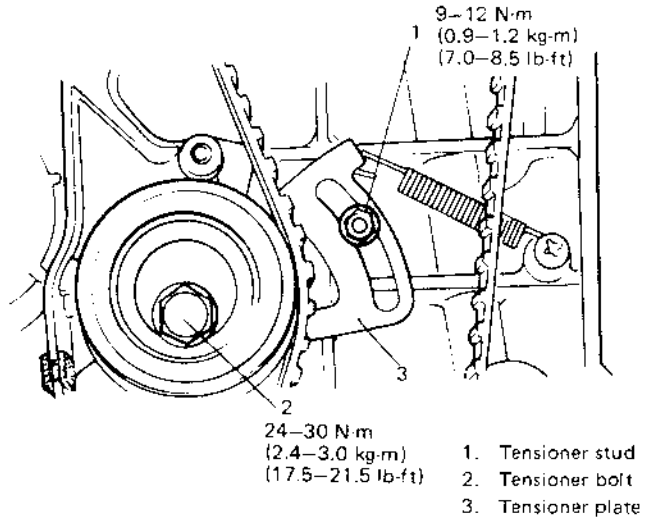


Fig. 3-6-51 Tensioner bolt and nut

11) Install timing belt outside cover.

Tightening torque for outside cover bolts and nuts	N·m	kg·m	lb·ft
	9 – 12	0.9 – 1.2	7.0 – 8.5

**Crankshaft Pulley, Water Pump Pulley and Alternator**

1) Install crankshaft pulley.

Fit keyway on pulley to key of crankshaft timing belt pulley, and tighten 4 bolts to specification, with flywheel holder (special tool 09924-17810) hitched to flywheel so that crankshaft will not turn.

Tightening torque for pulley bolts	N·m	kg·m	lb·ft
	10 – 13	1.0 – 1.3	7.5 – 9.0



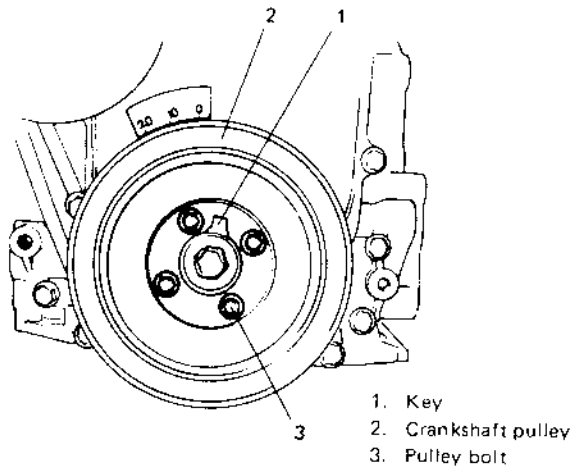


Fig. 3-6-52 Installing crankshaft pulley

- 2) Install alternator assembly.  
Tighten alternator ass'y securing bolts (3pcs) only to the extent to allow alternator to be moved by hand. Don't torque them tight.

**NOTICE:**

Adjust water pump belt tension to specification upon completion of installing engine ass'y to body and then cooling fan and water pump pulley. Make sure to refer to p. 1-5 of this manual for adjusting procedure.

**Distributor Case**

- 1) Install distributor case O-ring to cylinder head.
- 2) Install distributor case.
- 3) Tighten bolts to specified torque.

Tightening torque for case bolts	N·m	kg·m	lb·ft
	8 - 12	0.8 - 1.2	6.0 - 8.5

**CAUTION:**

After tightening case bolts, fill distributor case with about 30cc (1.02/1.06 US/Imp oz) engine oil.



Fig. 3-6-53

**Fuel Pump**

Install fuel pump rod, gasket and fuel pump to cylinder head.  
Apply engine oil to rod ① before installation. Use new gasket.



Fig. 3-6-54 Fuel pump rod installation

### Clutch Disc and Cover

Install clutch disc and cover.

For installation, refer to p. 11-7 of SECTION 11 CLUTCH in this manual and torque each bolt to specification.

### Transmission Assembly

- 1) Check to make sure that 2 pins ① are fitted to cylinder block.

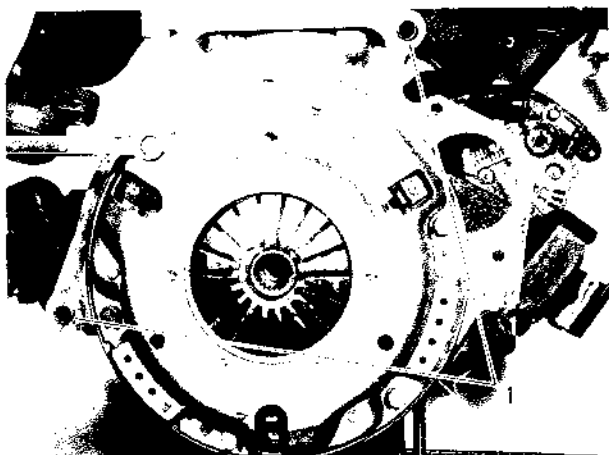


Fig. 3-6-55

- 2) Attach transmission assembly to engine cylinder block and tighten bolts and nuts to specified torque.

Tightening torque for transmission case bolts and nuts	N·m	kg·m	lb·ft
	22 – 35	2.2 – 3.5	16.0 – 25.0

### Distributor

- 1) Install distributor to case.

For installation, be sure to refer to SECTION 8 IGNITION SYSTEM in this manual.

### NOTICE:

Check and adjust ignition timing with engine installed to car body and after installing and connecting all necessary parts. For procedure, refer to p. 8-9 of SECTION 8 IGNITION SYSTEM in this manual.

### Valve Lash (Clearance) Adjustment

Adjust valve lash of all intake and exhaust valves to specification, referring to description on valve lash on p. 3-53 of this manual.

### Cylinder Head Cover

Install cover to cylinder head and tighten bolts to specified torque.

Tightening torque for cylinder head cover bolts	N·m	kg·m	lb·ft
	4 – 5	0.4 – 0.5	3.0 – 3.5

### 3-7. ENGINE INSTALLATION

- 1) Lower engine with transmission into vehicle, but do not remove lifting device.
- 2) Tighten engine mounting bracket bolts (right and left) and transmission mounting bolts to specification. Refer to p. 3-58.
- 3) Remove lifting device.
- 4) Reverse removal procedures for installation of remainder.
- 5) Adjust accelerator cable play and clutch cable play.
- 6) Connect vacuum hoses securely. Refer to section 5 "EMISSION CONTROL SYSTEM" for correct connection.
- 7) Connect wire harnesses and couplers securely.
- 8) Tighten bolts and nuts to specified torque. For individual specification, refer to each section.
- 9) Fill specified amount of specified transmission oil and engine oil. For the detail, refer to SECTION 1 PERIODIC MAINTENANCE SERVICE of this manual.
- 10) After adjusting water pump belt tension to specification, fill specified amount of engine cooling water.
- 11) Before starting engine, check again to ensure that all parts once disassembled or disconnected are back in place securely.
- 12) Start engine and check ignition timing. If it is not to specified timing, adjust it, referring to SECTION 8 of this manual.
- 13) After engine is started, check for oil leak, abnormal noise and other malcondition. Also, check each part for operation.

### 3-8. ENGINE MAINTENANCE SERVICE

#### Fan Belt

Adjust belt tension as outlined in SECTION 6 ENGINE COOLING SYSTEM (p. 6-10).

#### Ignition Timing

Refer to IGNITION TIMING, Page 8-9.

#### Carburetor

Adjustments to be made are detailed in SECTION 4 (p. 4-19).

#### Valve Lash (Clearance)

##### Valve lash specifications:

Valve lash refers to gap between rocker arm adjusting screw and valve stem. Use a thickness gauge to measure this gap (A).

Valve lash (gap A) specification		When cold (Coolant temperature is 15 – 25°C or 59 – 77°F)	When hot (Coolant temperature is 60 – 68°C or 140 – 154°F)
	Intake		0.13 - 0.17 mm (0.0051 - 0.0067 in)
Exhaust		0.16 - 0.20 mm (0.0063 - 0.0079 in)	0.26 - 0.30 mm (0.0102 - 0.0118 in)

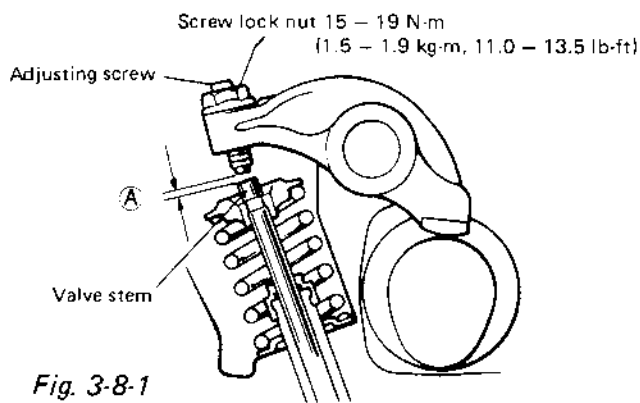


Fig. 3-8-1

#### Checking and adjusting procedures:

#### NOTICE:

- Refer to Fig. 3-3-11 of SECTION 3 for cylinder numbers (No. 1, No. 2, No. 3 and No. 4) mentioned in this section.
- When adjustment becomes necessary in step 4), loosen adjusting screw lock nut and then make adjustment by turning adjusting screw. After adjustment, tighten lock nut to specified torque while holding adjusting screw stationary with straight headed screwdriver, and then make sure again that gap (A) is within specification.

- 1) Remove cylinder head cover.
- 2) Remove ignition timing check window rubber plug from clutch housing of transmission case.
- 3) Turn crankshaft clockwise (viewing from crankshaft pulley side) to the extent that line ② above "T" mark punched on fly-wheel is aligned with match mark ① on transmission case as shown below, i.e. No. 1 cylinder piston reaches TDC position.

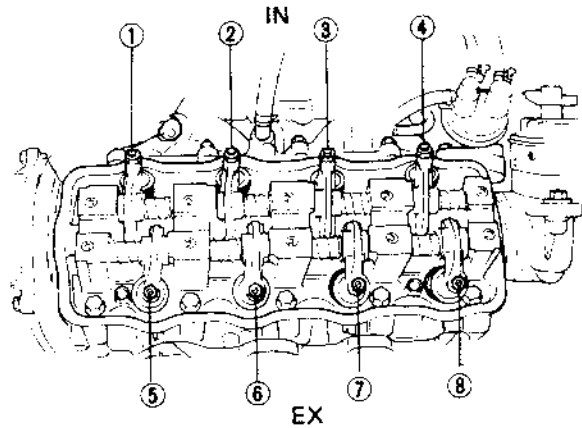


Fig. 3-8-4

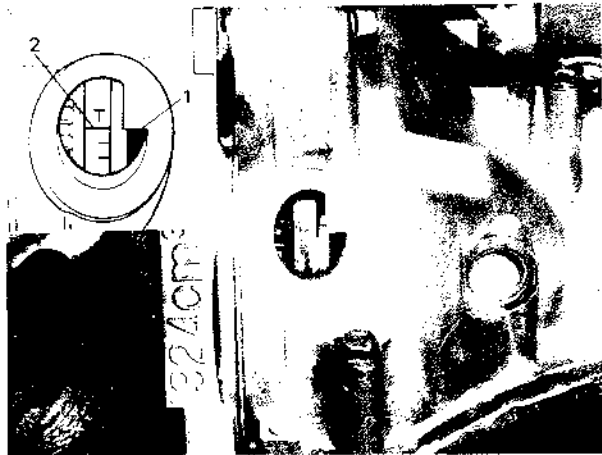


Fig. 3-8-2 1. Match mark 2. "T" (TDC) mark

- 4) Remove distributor cap and check that rotor is positioned as shown in figure. If rotor is out of place, turn crankshaft clockwise once ( $360^\circ$ ). In this state, check valve lashes at valves ①, ②, ⑤ and ⑦. Rotate crankshaft exactly one turn, and check the same at valves ③, ④, ⑥ and ⑧.

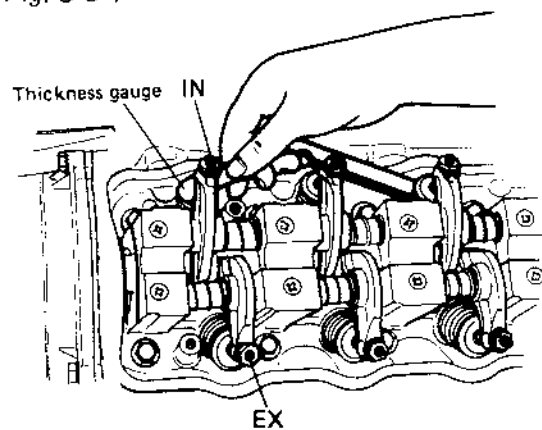


Fig. 3-8-5 Measuring valve lashes

- 5) Upon completion of check and adjustment, install cylinder head cover and torque bolts to specification.

Tightening torque for cylinder head cover bolts	N·m	kg·m	lb·ft
	4 - 5	0.4 - 0.5	3.0 - 3.5

- 6) Install distributor cap and connect blow-by gas hose to cylinder head cover.

#### Camshaft Timing Belt

For checking procedures of damage, wear and tension of camshaft timing belt, refer to SECTION 1 (p. 1-5) of this manual.

#### Engine Oil

Refer to SECTION 1 (p. 1-7) of this manual.

#### Engine Oil Filter

For removal and installation of filter, refer to SECTION 1 (p. 1-7) of this manual.



Fig. 3-8-3

### Engine Coolant

This subject is covered in SECTION 6 ENGINE COOLING SYSTEM.

### Exhaust Line and Muffler

Inspect each exhaust line connection for tightness, and examine muffler and other parts for evidence of breakage and leakage of gases. Repair or replace defective parts, if any.



Fig. 3-8-6

### Compression Pressure Measurement

Check compression pressure on all four cylinders as follows:

- 1) Warm up engine.
- 2) Stop engine after warming up.
- 3) Remove all spark plugs and disconnect high tension cord from ignition coil.
- 4) Install compression gauge (special tool) into spark plug hole.



1. Compression gauge (Special tool 09915-64510)

Fig. 3-8-7 Installing compression gauge

- 5) Disengage clutch (to lighten starting load on engine), and depress accelerator pedal all the way to make throttle full-open.
- 6) Crank engine with fully charged battery, and read the highest pressure on compression gauge.

	Compression pressure
Standard	14.0 kg/cm <sup>2</sup> (199.0 psi) 400 r/min
Limit	12.0 kg/cm <sup>2</sup> (170.0 psi) 400 r/min
Max. difference between any two cylinders	1.0 kg/cm <sup>2</sup> (14.2 psi), 400 r/min

- 7) Carry out steps 4) through 6) on each cylinder to obtain four readings.

### NOTICE:

Compression pressure value is measured by using compression gauge (Special tool 09915-64510).

### Oil Pump Discharge Pressure Measurement

### NOTICE:

Prior to checking oil pressure, check the following.

- Oil level in oil pan.  
If level is low, add oil up to Full level hole on oil level gauge.
- Oil quality.  
If oil is discolored, or deteriorated, change oil. For particular oil to be used, refer to table on p 1-8 of SECTION 1.
- Oil leak.  
If leak is found, repair it.

- 1) Disconnect lead wire from oil pressure switch.
- 2) Remove oil pressure switch from cylinder block.



Fig. 3-8-8 Oil pressure switch

- 3) Install oil pressure gauge (special tool) to vacated threaded hole.



1. Oil pressure gauge (Special tool 09915-77310)

Fig. 3-8-9 Oil pressure gauge installation

- 4) Start engine and warm it up to normal operating temperature.
- 5) After warming up, raise engine speed to 3,000 r/min and measure oil pressure.

Oil pressure specification	3.0 – 4.2 kg/cm <sup>2</sup> 42.7 – 59.7 psi at 3,000 r/min (rpm)
----------------------------	---

- 6) After checking oil pressure, stop engine and remove oil pressure gauge.
- 7) Before reinstalling oil pressure switch, be sure to wrap its screw threads with sealing tape and tighten switch to specified torque.

Tightening torque for oil pressure switch	12 – 15 N·m 1.2 – 1.5 kg·m 9.0 – 10.5 lb·ft
---	---

**NOTICE:**

- If sealing tape edge is bulged out from screw threads of switch, cut off edge.

- 8) After installing oil pressure switch, start engine and check switch for oil leakage.

**Vacuum Measurement**

Engine vacuum that develops in intake line is a good indicator of engine condition. Vacuum checking procedure is as follows:

- 1) Warm up engine to normal operating temperature.
- 2) Install vacuum gauge (A) (09915-67310), as shown in Fig. 3-8-10. Install engine tachometer.



Fig. 3-8-10

- 3) Run engine at specified idling speed and, under this running condition, read vacuum gauge. Vacuum should not be lower than 45 cm Hg (17.7 in. Hg).

A low vacuum reading means that any combination of following malconditions is the cause, which must be corrected before releasing machine to customer:

- (a) Leaky cylinder head gasket
- (b) Leaky inlet manifold gasket
- (c) Leaky valves
- (d) Weakened valve springs
- (e) Maladjusted valve clearance
- (f) Valve timing out of adjustment
- (g) Ignition mistimed
- (h) Carburetor improperly adjusted

**NOTICE:**

Should indicating hand of the vacuum gauge oscillate violently, turn adjusting nut ② to steady it.

Standard vacuum (sea level)	45 – 55 cm Hg (17.7 – 21.6 in. Hg)
Idling speed specification	800 ± 50 r/min (rpm) (Take vacuum reading at this speed.)

- 4) After checking, remove vacuum gauge.
- 5) Before reinstalling vacuum checking plug, be sure to wrap its screw threads with sealing tape and tighten plug.

**Oil Filler Cap**

The cap has a packing. Be sure that packing is in good condition, free of any damage and signs of deterioration, and is tight in place: it is replaceable.

### 3-9. RECOMMENDED TORQUE SPECIFICATIONS

Fastening parts	Tightening torque		
	N-m	kg-m	lb-ft
1. Cylinder head bolt	63 – 70	6.3 – 7.0	46.0 – 50.5
2. Cylinder head cover bolt	4 – 5	0.4 – 0.5	3.0 – 3.5
3. Spark plug	20 – 30	2.0 – 3.0	14.5 – 21.5
4. Distributor gear case	8 – 12	0.8 – 1.2	6.0 – 8.5
5. Rocker arm shaft screw	9 – 12	0.9 – 1.2	7.0 – 8.5
6. Valve adjusting screw lock nut	15 – 19	1.5 – 1.9	11.0 – 13.5
7. Crankshaft main bearing cap bolt	50 – 57	5.0 – 5.7	36.5 – 41.0
8. Oil filter stand	20 – 25	2.0 – 2.5	14.5 – 18.0
9. Oil filter Ass'y	12 – 16	1.2 – 1.6	9.0 – 11.5
10. Oil pressure switch	12 – 15	1.2 – 1.5	9.0 – 10.5
11. Oil drain plug	30 – 40	3.0 – 4.0	22.0 – 28.5
12. Oil pan bolt and nut	9 – 12	0.9 – 1.2	7.0 – 8.5
13. Oil pump strainer bolt	9 – 12	0.9 – 1.2	7.0 – 8.5
14. Water pump bolt and nut	9 – 12	0.9 – 1.2	7.0 – 8.5
15. Cooling fan nut	8 – 12	0.8 – 1.2	6.0 – 8.5
16. Flywheel bolt	57 – 65	5.7 – 6.5	41.5 – 47.0
17. Oil seal housing bolt	9 – 12	0.9 – 1.2	7.0 – 8.5
18. Connecting rod bearing cap nut	33 – 37	3.3 – 3.7	24.0 – 26.5
19. Crankshaft pulley bolt	10 – 13	1.0 – 1.3	7.5 – 9.0
20. Crankshaft timing belt pulley bolt	65 – 75	6.5 – 7.5	47.5 – 54.0
21. Timing belt cover bolt and nut	9 – 12	0.9 – 1.2	7.0 – 8.5
22. Camshaft timing pulley bolt	56 – 64	5.6 – 6.4	41.0 – 46.0
23. Timing belt tension bolt	24 – 30	2.4 – 3.0	17.5 – 21.5
24. Timing belt tensioner stud	9 – 12	0.9 – 1.2	7.0 – 8.5
25. Oil pump case bolt	9 – 12	0.9 – 1.2	7.0 – 8.5
26. Oil pump rotor plate screw	9 – 12	0.9 – 1.2	7.0 – 8.5
27. Inlet & exhaust manifold nut	18 – 28	1.8 – 2.8	13.5 – 20.0
28. Fuel pump nut	10 – 16	1.0 – 1.6	7.0 – 11.5
29. Engine mounting bracket frame side bolt	40 – 60	4.0 – 6.0	29.0 – 43.0
30. Engine mounting bracket engine side bolt	50 – 60	5.0 – 6.0	36.5 – 43.0
31. Engine mounting nut	40 – 50	4.0 – 5.0	29.0 – 36.0
32. Transmission mounting bracket bolt	18 – 28	1.8 – 2.8	13.5 – 20.0
33. Transmission mounting bolt	18 – 28	1.8 – 2.8	13.5 – 20.0
34. Transmission mounting and frame bolt	18 – 28	1.8 – 2.8	13.5 – 20.0
35. Propeller shaft flange bolt and nut	23 – 30	2.3 – 3.0	17.0 – 21.5

**NOTICE:** If specified tightening torque for particular bolt or nut is not included here, refer to p 0-12 of this manual.



# SECTION 4

## FUEL SYSTEM

### CONTENTS

4-1. CARBURETOR .....	4-2
GENERAL DESCRIPTION .....	4-2
REMOVAL AND INSTALLATION .....	4-12
UNIT REPAIR OVERHAUL .....	4-13
MAINTENANCE SERVICES .....	4-19
4-2. AIR CLEANER .....	4-29
GENERAL DESCRIPTION .....	4-29
MAINTENANCE SERVICES .....	4-29
4-3. FUEL PUMP, FILTER AND LINES .....	4-31
GENERAL DESCRIPTION .....	4-31
REMOVAL AND INSTALLATION .....	4-33
MAINTENANCE SERVICES .....	4-35
4-4. ACCELERATOR PEDAL .....	4-36

**IMPORTANT:**

THE ENGINE OF THIS VEHICLE REQUIRED THE USE OF UNLEADED FUEL ONLY. USE OF LEADED AND/OR LOW LEAD FUEL CAN RESULT IN ENGINE DAMAGE AND REDUCE THE EFFECTIVENESS OF THE EMISSION CONTROL SYSTEMS.

## 4-1. CARBURETOR

### GENERAL DESCRIPTION

#### General

This 2-barrel, downdraft type carburetor has primary and secondary systems.

The primary system operates under normal driving condition, and the secondary system operates under high speed-high load driving condition. The choke valve is provided in the primary system.

The main components and their functions are as follows.

- The primary system has; (1) a mixture control solenoid valve which is operated by the electrical signals from the Electronic Control Module (ECM) so as to maintain the optimum air fuel ratio of the primary slow and the primary main systems at all times, (2) a fuel cut solenoid valve which is for the fuel cut under deceleration and prevention of the dieseling, and (3) an acceleration pump system.
- The secondary system has a secondary diaphragm which is operated by the vacuum from the primary side and actuates the secondary throttle valve.
- The choke system is a full automatic type using a thermo-wax.
- The switch vent solenoid valve provided on top of the float chamber is to reduce the evaporative emissions.

1. Air horn
2. Float chamber
3. Throttle chamber
4. Pump boot
5. Pump lever
6. Pump rod
7. Bracket
8. Screw
9. Thermo element holder
10. Seal
11. Thermo element
12. Choke piston
13. Delay valve
14. Switch vent solenoid
15. Vacuum switching valve
16. 3 way joint
17. Vacuum transmitting valve
18. Primary slow air No. 1 bleeder
19. Secondary slow air bleeder
20. Mixture control solenoid valve
21. Solenoid valve seal
22. Needle valve filter
23. Needle valve gasket
24. Needle valve
25. Float
26. Air horn gasket
27. Connector (5 terminal)
28. Connector (4 terminal)
29. Connector (1 terminal)
30. Injector weight
31. Injector spring
32. Injector weight
33. Ball
34. Primary slow air No. 2 bleeder
35. Primary slow jet
36. Primary main air bleeder
37. Secondary main air bleeder
38. Spring
39. Secondary slow jet
40. Idle micro switch
41. Wide open micro switch
42. Idle up actuator
43. Solenoid valve (Fuel cut)
44. Washer
45. Level gauge seal
46. Level gauge
47. Level gauge gasket
48. Micro switch bracket
49. Primary main jet
50. Secondary main jet
51. Drain plug gasket
52. Drain plug
53. Float pin
54. Insulator
55. Secondary actuator (diaphragm)

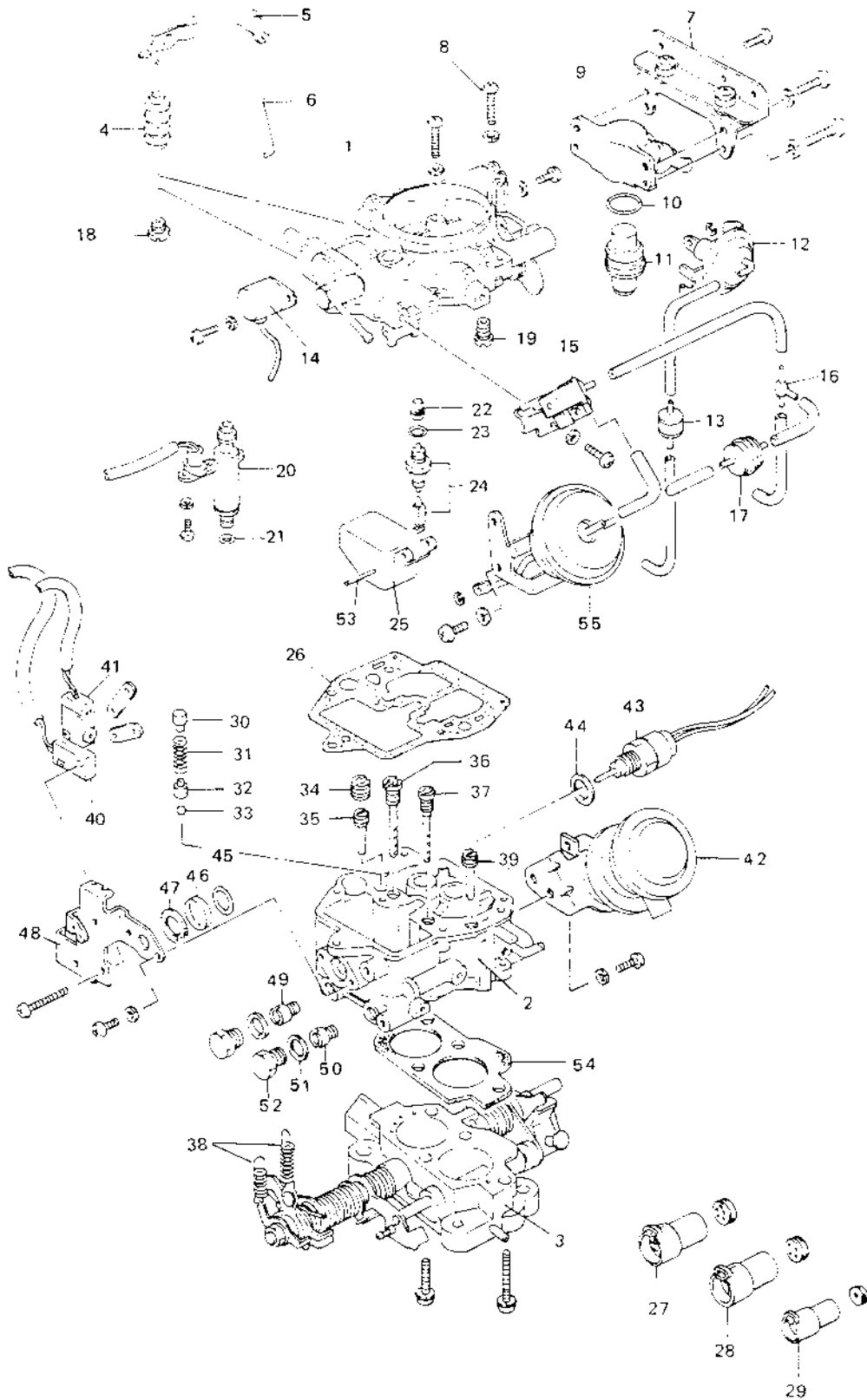


Fig. 4-1-1 Carburetor exploded view

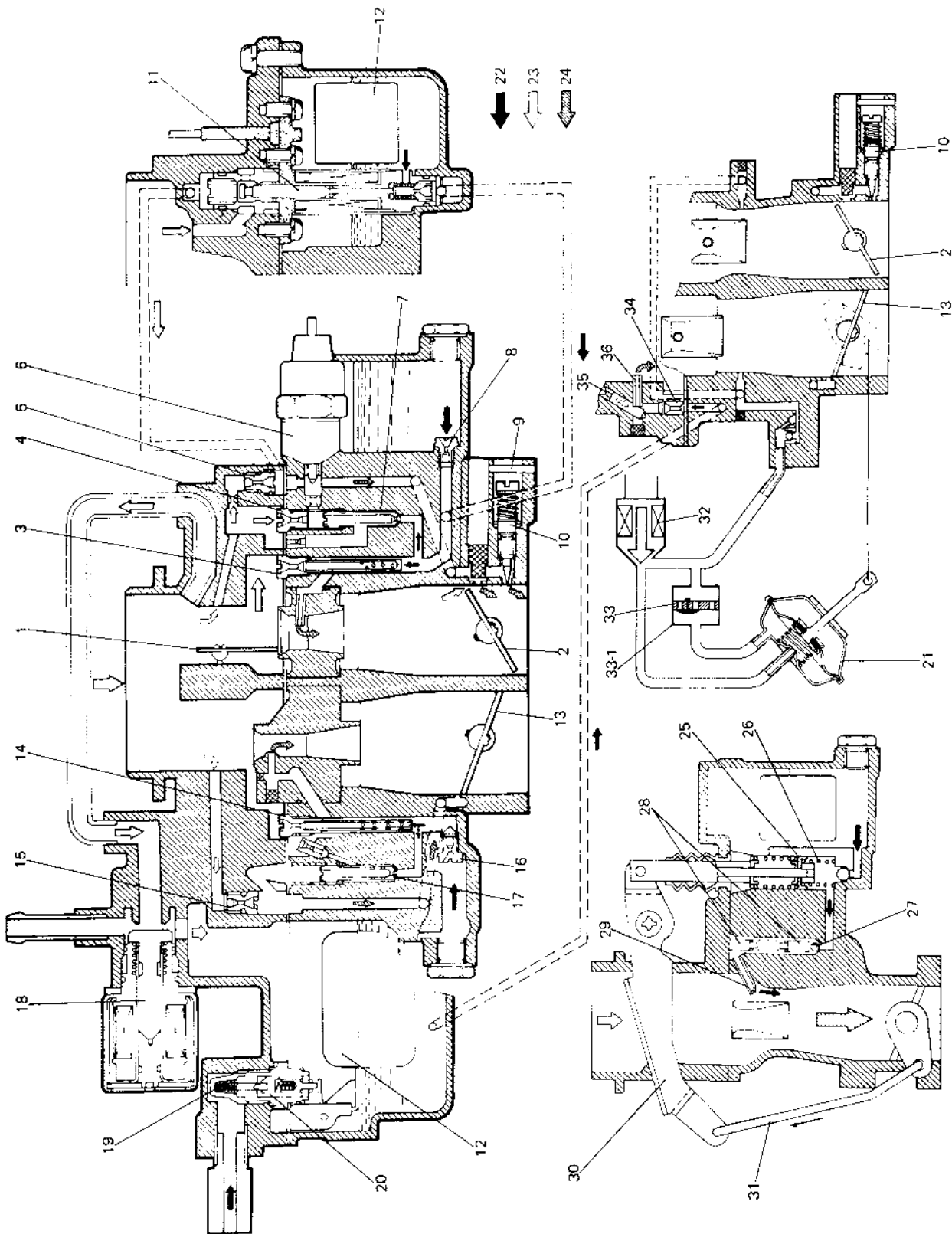
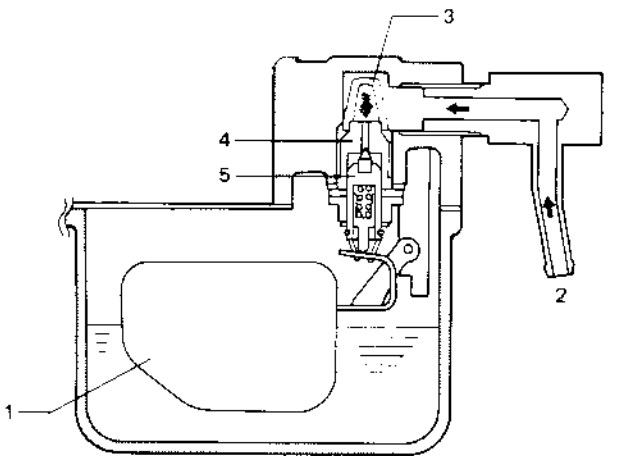


Fig. 4-1-2 Carburetor cross-section

1. Choke valve
2. Primary throttle valve
3. Primary main air bleeder
4. Primary slow air No. 2 bleeder
5. Primary slow air No. 1 bleeder
6. Solenoid valve (Fuel cut)
7. Primary slow jet
8. Primary main jet
9. Mixture adjusting screw pin
10. Mixture adjusting screw
11. Mixture control solenoid valve
12. Float
13. Secondary throttle valve

14. Secondary main air bleeder
15. Secondary slow air bleeder
16. Secondary main jet
17. Secondary slow jet
18. Switch vent solenoid
19. Needle valve filter
20. Needle valve
21. Secondary (actuator) diaphragm
22. Fuel
23. Air
24. Air/Fuel mixture
25. Pump piston
26. Return spring

27. Ball
28. Injector weight
29. Discharge nozzle
30. Pump lever
31. Pump rod
32. VSV (Vacuum switching valve)
33. VTV (Vacuum transmitting valve)
- 33-1 Brown side
34. Richer jet
35. Richer air bleeder
36. Richer nozzle



1. Float
2. From fuel pump
3. Needle valve filter
4. Needle valve seat
5. Needle valve

Fig. 4-1-3 Float system

## Float System

The float system consists of a float chamber, a float, a float needle valve and seat, and needle valve filter. Fuel from the fuel pump enters the float chamber, passing through the needle valve filter and the needle valve.

The float's function is to maintain a constant level in the chamber.

As the fuel level in the chamber drops, the float and the needle valve drops down allowing the fuel to enter the chamber. As the fuel enters the chamber, the float and the needle valve again rise to close the fuel inlet.

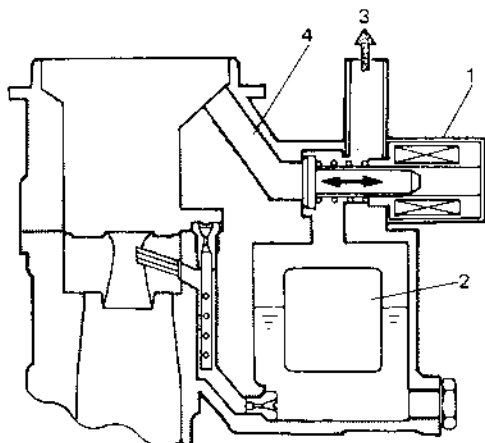
A constant fuel level in the chamber is maintained through the repetition of this cycle.

### [Switch vent solenoid]

Provided on top of the float chamber is a switch vent solenoid which is connected to the ignition switch through ECM. As the ignition switch is operated, the solenoid opens and closes its valve so as not to release the fuel vapor in the float chamber out into the atmosphere.

When the ignition switch is turned to "OFF" position, the passage connecting the inner vent passage and the float chamber will close, and the passage connecting the float chamber and the canister will open, then the fuel vapor will flow into the canister.

When the ignition switch is turned to "ON" position, and engine speed is above 400 r/min, the passage connecting the float chamber and the canister will close, and the passage connecting the float chamber and the inner vent passage will open, then the fuel vapor will flow into the carburetor bore.



1. Switch vent solenoid
2. Float
3. To canister
4. Inner vent passage

Fig. 4-1-4 Switch vent solenoid

### Primary System

#### [Primary slow system]

The fuel, after passing through the main jet, is metered by the primary slow jet, then mixed with the air from the primary slow air No. 2 bleeder. This air/fuel mixture is further blended with the air from the primary slow air No. 1 bleeder and air supplied through the mixture control solenoid. Then the air/fuel mixture passes through the idle down channel and enters the carburetor bore through the off idle discharge port and the idle discharge hole.

#### [Mixture control solenoid valve]

The primary system has the Mixture Control Solenoid (MCS) Valve. In the MCS, there is a plunger which makes 16 up and down movements per second by the electrical signals from the Electronic Control Module (ECM). That is, when an electrical signal is received by the solenoid, the plunger will move down and when no signal is received, the plunger will move up by the spring force.

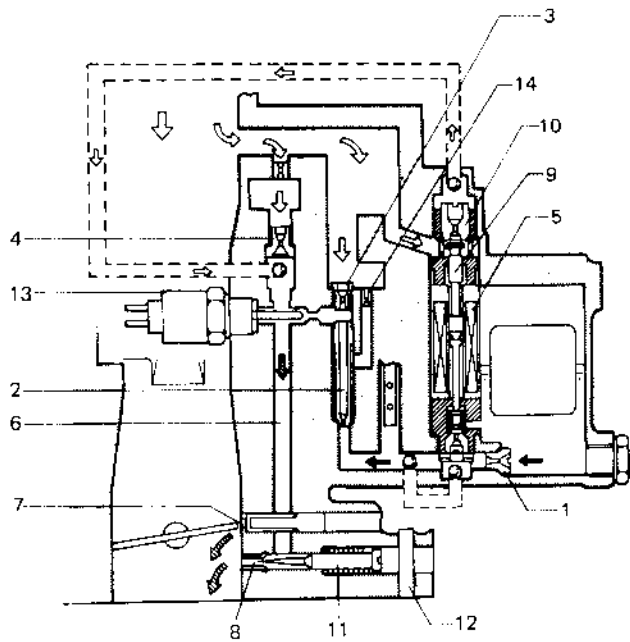
When the plunger moves down, the air jet located on the upper side of the mixture control solenoid valve will open as shown in below figure, allowing the air to flow into the idle down channel. In this condition, the mixture will become lean.

On the other hand, when the plunger is pushed up by the spring, the air jet will close, shutting off the air flow into the idle down channel. In this condition, the mixture will become rich.

The up and down movement of the plunger at the rate of 16 times per second to the signals from the ECM controls the air/fuel mixture to the optimum ratio at all times and as a result helps to improve the emission and engine performances, and fuel economy.

The ECM receives the electrical information from the oxygen sensor installed to the exhaust manifold and the engine operating condition signals from other devices and sends out and stops the electrical signal to the mixture control solenoid valve to actuate the plunger up and down 16 times every second. The ECM is located under the glove box of the instrument panel.

- Since the mixture control solenoid valve is factory adjusted, it must not be overhauled or its jets must not be removed.
- Since the mixture adjust screw is also factory adjusted, it must not be adjusted at the field except the following.
  - a. When the carburetor assembly has been replaced.
  - b. When the carburetor has been overhauled.
  - c. When the idle mixture adjustment is necessary due to the emission test failures.
 To adjust the mixture adjust screw in one of the above conditions, drive out the pin in front of the screw. After the adjustment, a new pin should be installed.

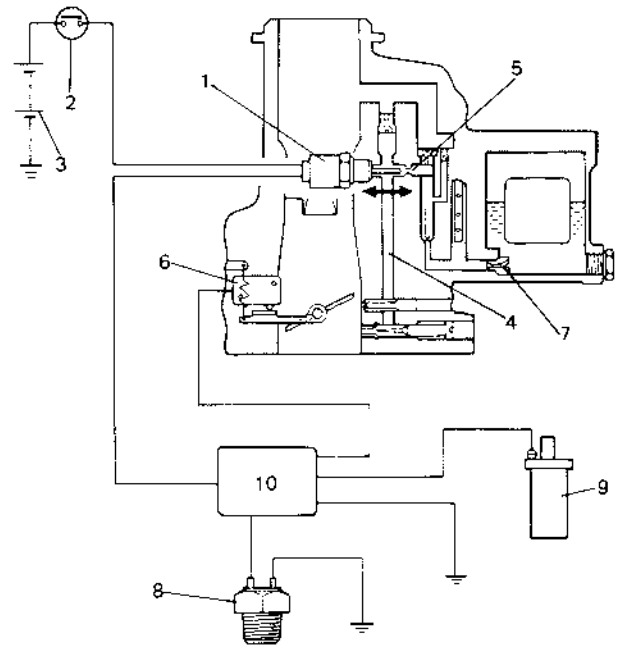


1. Primary main jet
2. Primary slow jet
3. Primary slow air No. 2 bleeder
4. Primary slow air No. 1 bleeder
5. Mixture control solenoid valve
6. Idle down channel
7. Off idle discharge port
8. Idle discharge hole
9. Plunger
10. Air jet
11. Mixture adjusting screw
12. Pin
13. Solenoid valve (Fuel cut)
14. Economizer air bleeder

Fig. 4-1-5 Primary slow system

[Fuel cut system]

The primary slow system incorporates the fuel cut system with the fuel cut solenoid valve which is operated by the ignition switch and the ECM. When the ignition switch is at "OFF" position or during deceleration, the fuel cut solenoid valve stops the fuel flow into the idle down channel by closing the fuel passage. Thus the fuel cut system helps to prevent the dieseling and improve the emission performance and fuel economy. For details, refer to SECTION 5 "EMISSION CONTROL SYSTEM".



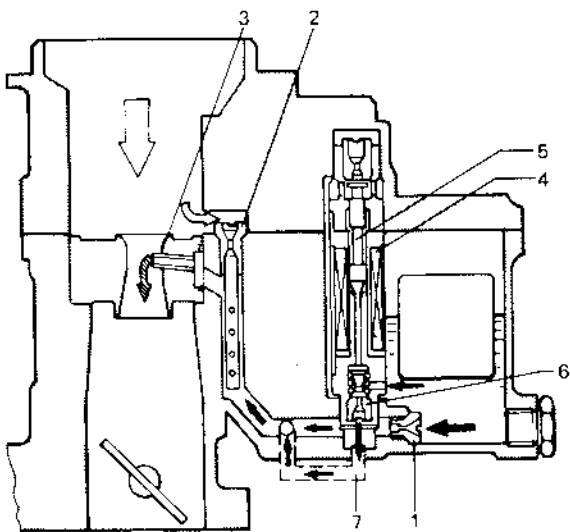
1. Fuel cut solenoid valve
2. Ignition switch
3. Battery
4. Idle down channel
5. Fuel passage
6. Idle micro switch
7. Primary main jet
8. Thermal switch
9. Ignition coil
10. ECM

Fig. 4-1-6 Fuel cut system

### [Primary main system]

The fuel metered by the primary main jet is mixed with the air from the primary main air bleeder and then is discharged into the carburetor bore through the main discharge nozzle. When the plunger of the MCS is at the up position (i.e. the ECM electrical signal is not received by the MCS), the fuel orifice of the MCS is open. In this state, the fuel is allowed to flow into the fuel passage through this orifice in addition to the main jet and the mixture becomes rich.

On the other hand, when the plunger is at the down position (i.e. the ECM signal is received by the MCS), the fuel orifice is closed. In this state, the fuel flows into the fuel passage only through the main jet and therefore the mixture becomes lean. In this way, the mixture is maintained to the optimum air/fuel ratio at all times by the plunger which moves up and down at a frequency of 16 times per second according to the electrical signals from the ECM.



1. Primary main jet
2. Primary main air bleeder
3. Main discharge nozzle
4. Mixture control solenoid valve
5. Plunger
6. Fuel orifice
7. Fuel passage

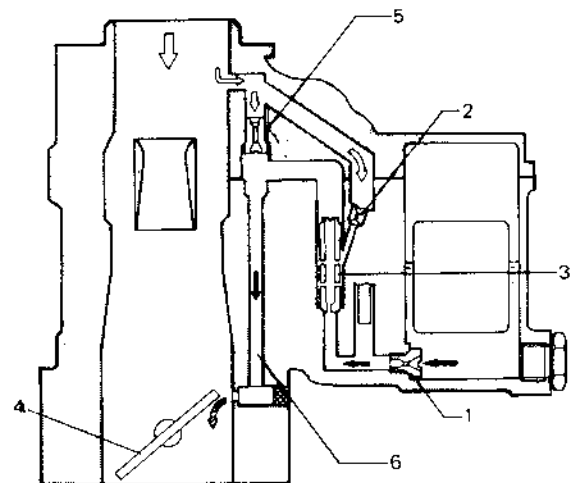
Fig. 4-1-7 Primary main system

### Secondary System

#### [Secondary slow system]

This system operates during the transition period from the primary main system to the secondary main system. When the primary throttle valve is open nearly  $54^\circ$  and the vacuum in "A" as shown in the below figure exceeds specification, the diaphragm pulls up the rod.

In this state, the secondary throttle valve is ready to open at any time when the primary throttle valve opens further. When the secondary throttle valve opens, the fuel discharged through the secondary main jet is mixed with the air from the economizer air bleeder at the secondary slow jet. Then it is further blended with the air from the secondary slow air bleeder and enters into the carburetor bore through the idle down channel.



1. Secondary main jet
2. Economizer air bleeder
3. Secondary slow jet
4. Secondary throttle valve
5. Secondary slow air bleeder
6. Idle down channel

Fig. 4-1-8 Secondary slow system



**[Secondary main system]**

Operation of the secondary throttle valve is also controlled by the VTV and VSV. When the VSV is closed, the vacuum to be applied to the secondary diaphragm passes the VTV side and the secondary throttle valve opens gradually.

When the primary throttle valve opens almost fully, the VSV opens according to the signal from the ECM. Then the vacuum is applied directly to the secondary diaphragm and the secondary throttle valve responds to intensity of vacuum. When the secondary throttle valve opening is wider than when secondary slow system operates, the fuel is discharged through the secondary main jet and mixed with the air from the secondary main air bleeder. The air/fuel mixture is discharged into the carburetor bore through the main discharge hole.

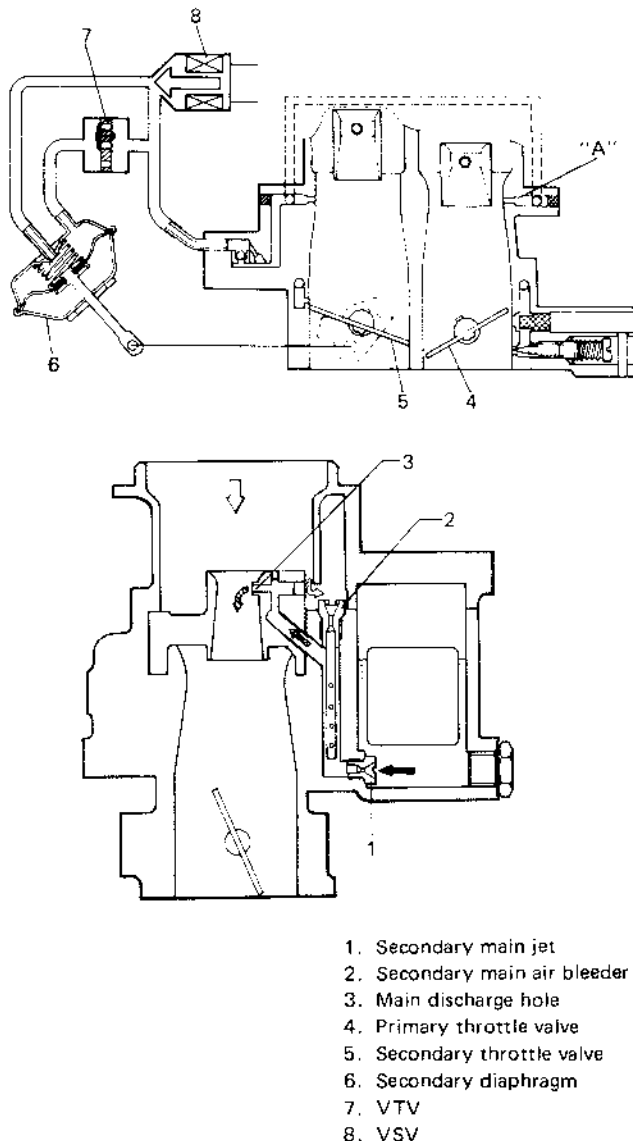


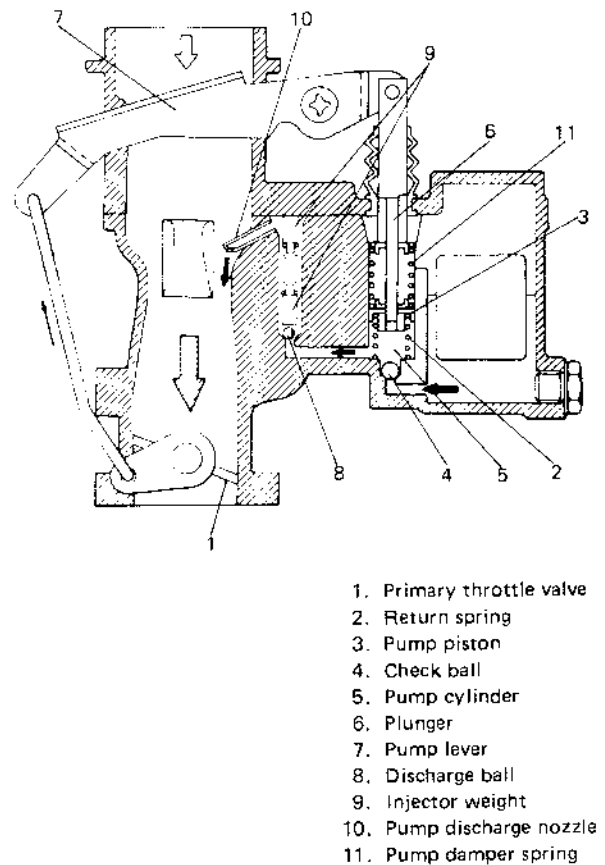
Fig. 4-1-9 Secondary main system

**Acceleration Pump System**

This system operates to supply extra fuel to the primary side only during the acceleration.

When the primary throttle valve closes, the return spring pushes up the pump piston. Then the fuel pushes up the check ball and enters into the pump cylinder. When the throttle valve opens during the acceleration, simultaneously the pump piston is pushed down by means of the pump lever. Then the fuel in the pump cylinder pushes up the discharge ball and the lower injector weight and discharges into the carburetor bore from the pump discharge nozzle.

In this way, a higher acceleration performance is provided by this system.



- 1. Primary throttle valve
- 2. Return spring
- 3. Pump piston
- 4. Check ball
- 5. Pump cylinder
- 6. Plunger
- 7. Pump lever
- 8. Discharge ball
- 9. Injector weight
- 10. Pump discharge nozzle
- 11. Pump damper spring

Fig. 4-1-10 Acceleration pump system

## Choke System

This choke system is provided with a thermo-wax which operates according to the heat from the engine coolant, causing the choke valve to open and close as well as the fast idle system to operate automatically.

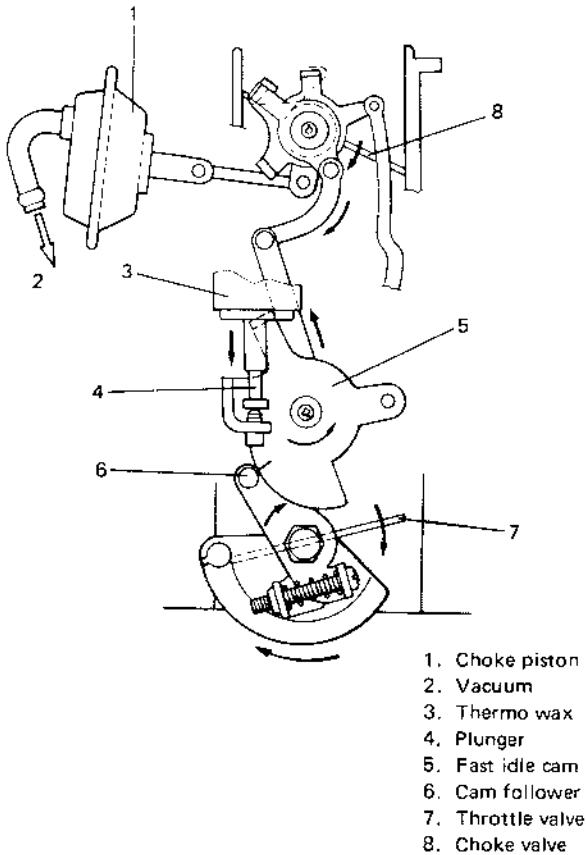


Fig. 4-1-11 Choke system

### [Operation of choke system]

As the thermo-wax is contracted at the low coolant temperature, the plunger of the thermo-wax is retracted (at the up position) and the fast idle cam rotates clockwise by the spring force. As a result, the cam follower pushed down by the cam causes the primary throttle valve to open and brings about the fast idle state.

The thermo-wax expands as the coolant temperature rises and the plunger position lowers, causing the fast idle cam to rotate counterclockwise. As a result, the throttle valve starts moving to close. In this way, the throttle valve closes gradually as the coolant temperature rises until it reaches the idling position at the normal temperature. Refer to Fig. 4-1-11.

### 1) When coolant temperature is low:

As the thermo-wax is contracted and the plunger is retracted, the choke valve linked with the fast idle cam is closed. When the engine is started in this state, the intake manifold vacuum pulls the diaphragm of the choke piston to the left (below figure). The choke piston rod also moves to the left and acts on the choke valve to open. However, the choke valve is restricted by the plunger of the thermo-wax through the choke lever. Therefore, the rod cannot move to the left far enough to open the choke valve wide and has to stop at a position where the choke valve opening is small as shown in the figure. In this state, the diaphragm contracts the bucking spring.

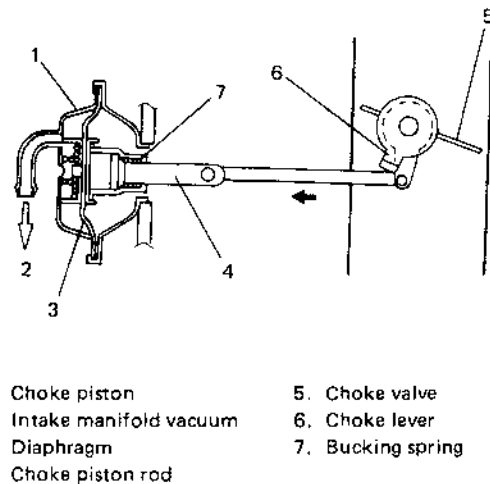


Fig. 4-1-12 When coolant temp. is low

### 2) When the coolant temperature rises:

The plunger lowers due to the expansion of the thermo-wax. Then the fast idle cam rotates counterclockwise and consequently the choke lever clockwise. This allow the rod to move further to the left by the bucking spring force (below figure). Thus a wide opening of the choke valve is obtained.

Hereafter, the plunger of the thermo-wax moves futher down in accordance with the coolant temperature rise. The lower the plunger moves, the wider the choke valve opening becomes, and it becomes fully open at the normal coolant temperature.

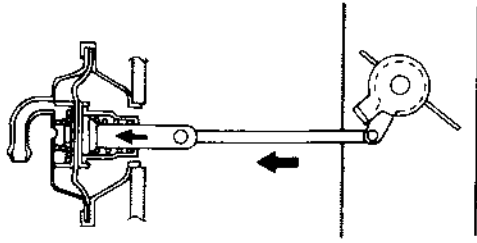


Fig. 4-1-13 When coolant temp. rises

**[Unloader system]**

If accelerator pedal is depressed for acceleration while the opening of the choke valve is small, the throttle lever pulls down the unloader lever and the choke valve opens up temporarily for smooth acceleration.

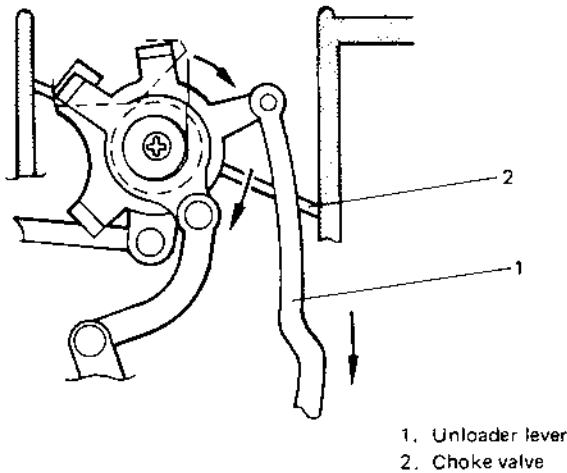


Fig. 4-1-14 Unloader system

**Idle Up System**

This system operates at idling and compensates the idle speed;

- 1) When any one of following electric loads is operating.
  - Small light, tail light, side marker light & license light
  - Rear defogger (if equipped)
  - Heater fan

- 2) When car is at a high altitude (higher than 1,220 m (4,000 ft) and HAC is ON).
- 3) When temperature in engine room is cold (below 7°C (44°F) and thermal switch is ON).
- 4) When engine speed after engine start is lower than 1,500 r/min.

The ECM sends an electric signal to the Three Way Solenoid Valve (TWSV). Receiving the signal, the TWSV opens its inner valve and transmits the manifold vacuum to the idle-up diaphragm. As the diaphragm moves down by the vacuum, the rod move down and push the throttle lever to open the throttle valve a little for the idle-up state.

In this way, the idle-up system helps to stabilize the idle speed even when electric loads operate. When electric loads stop operating, the TWSV closes. Then the idle-up diaphragm as well as rod moves back up, thus the idle-up state is released.

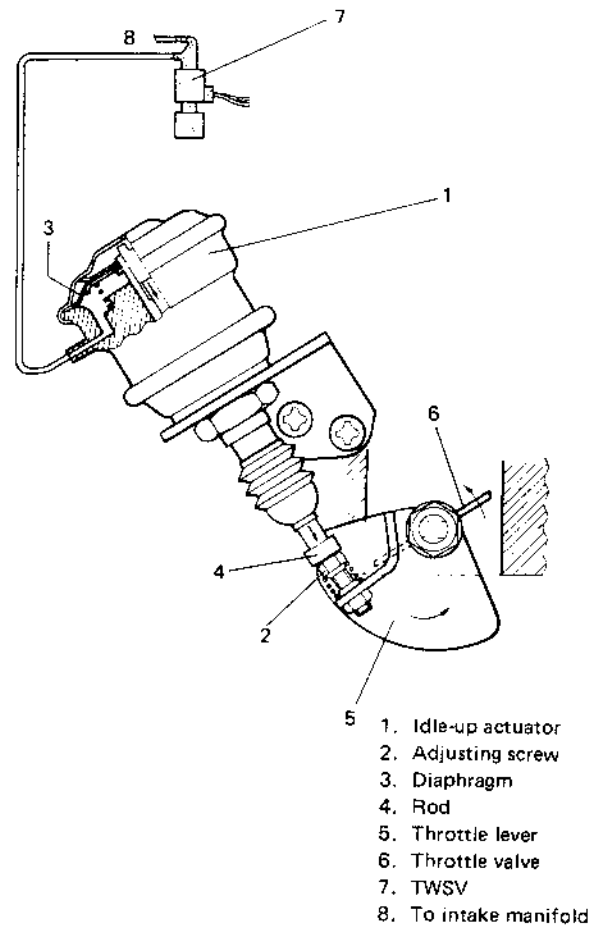


Fig. 4-1-15 Idle-up system operation

## REMOVAL AND INSTALLATION

### IMPORTANT:

Removal and installation of carburetor must be carried out in a well-ventilated place where no fire is used around.

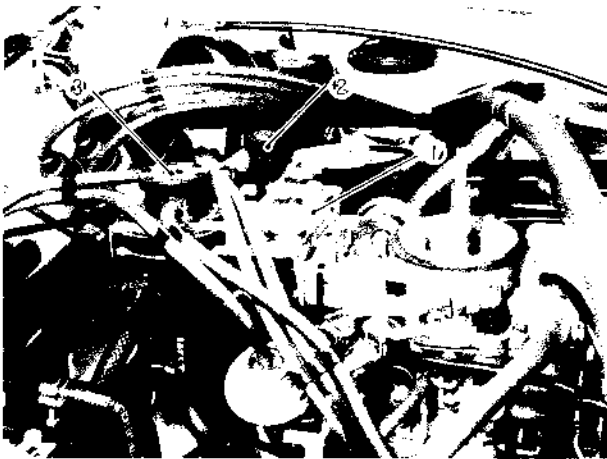
### Removal

- 1) Disconnect negative battery cord from battery.
- 2) Drain coolant.

### IMPORTANT:

To help avoid the danger of being burned, do not remove the drain plug and the radiator cap while the engine and radiator are still hot. Scalding fluid and steam can be blown out under pressure if the plug and cap are taken off too soon.

- 3) Remove air intake case from carburetor.
- 4) Disconnect micro switches, switch vent solenoid valve, fuel cut solenoid valve and MCSV lead wires at their couplers.
- 5) Disconnect VSV coupler from VSV.
- 6) Detach bracket with EGR modulator and TWSV from carburetor.



1. Bracket
2. TWSV
3. EGR modulator

Fig. 4-1-16

- 7) Disconnect water inlet and outlet hoses from carburetor.
- 8) Disconnect accelerator cable from carburetor.

- 9) Disconnect vacuum hoses from idle up actuator and carburetor.
- 10) To release the pressure in fuel tank, remove fuel tank filler cap and then, reinstall it.
- 11) Disconnect fuel inlet hose from carburetor.
- 12) Check all around carburetor for any other parts required to be removed or disconnected for removal of carburetor and remove or disconnect whatever necessary.
- 13) Remove carburetor from intake manifold.



Fig. 4-1-17

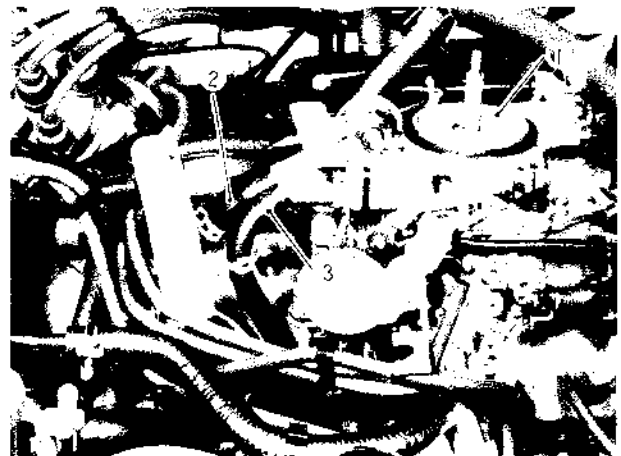
### Installation

Install in the reverse order of removal using care for the following.

- Install carburetor to intake manifold. Tighten 4 carburetor nuts to the specified torque.

Tightening torque for nuts	18 – 28 N·m
	1.8 – 2.8 kg·m
	13.5 – 20.0 lb·ft

- Connect water hoses to carburetor.



1. Carburetor
2. Inlet hose
3. Outlet hose

Fig. 4-1-18

- Connect electric couplers securely.
- Connect accelerator cable to carburetor. With the accelerator pedal released, adjust the cable play to specification. This adjustment can be made by turning the adjusting nut. After adjustment, tighten the lock nut. Refer to p. 4-19.
- Connect vacuum hoses securely.
- Refill cooling system.
- Connect negative cable at battery.

**NOTICE:**

Upon completion of installation, be sure to check each part for evidence of fuel leakage and for proper operation. If defective, correct.

**UNIT REPAIR OVERHAUL**

This section outlines procedure to be used for overhauling carburetor as removed from engine. For removal and installation of carburetor from and to engine, refer to the previous page.

**NOTICE:**

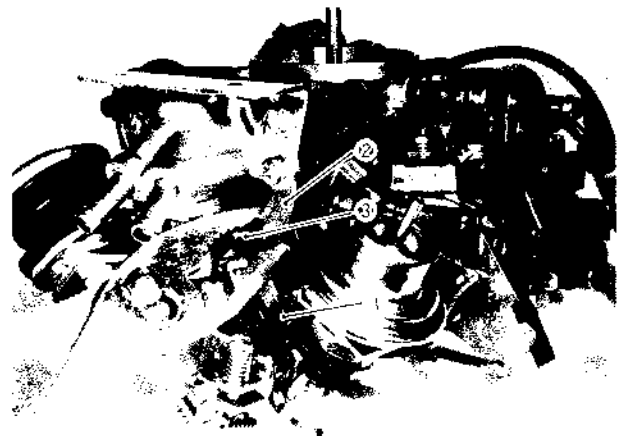
- Be sure to replace gaskets as well as worn or damaged parts.
- While disassembling and assembling carburetor, use special care not to deform levers on throttle valve shaft or cause damage to any other parts.
- Don't disassemble mixture control solenoid valve and accelerator pump piston.
- Don't remove idle and wide open micro switches from the bracket where they are installed.

**IMPORTANT:**

Keep lighted cigarette and any other fire off near carburetor as it contains gasoline, when servicing carburetor.

**Disassembly**

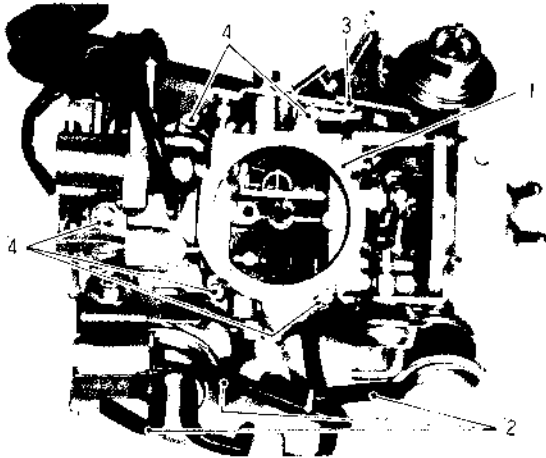
- 1) Turn fast idle cam counterclockwise and insert a pin available into holes on cam and bracket to lock the cam.



1. Fast idle cam
2. Bracket
3. Pin

*Fig. 4-1-19*

2) Remove air horn from float chamber after disconnecting three hoses and pump lever and removing five screws of air horn. Loosen idle up bracket screw.

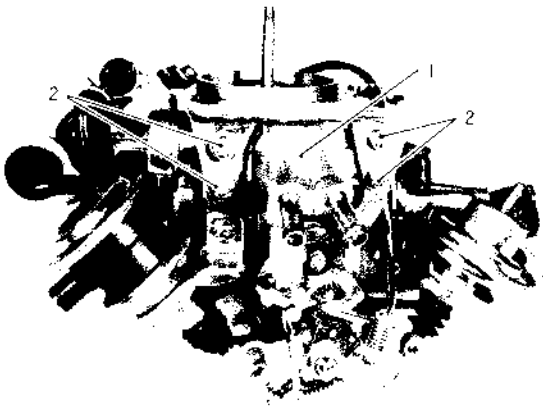


- 1. Air horn
- 2. Hose
- 3. Pump lever
- 4. Screw

Fig. 4-1-20 Air horn and hoses, etc.

**NOTICE:**

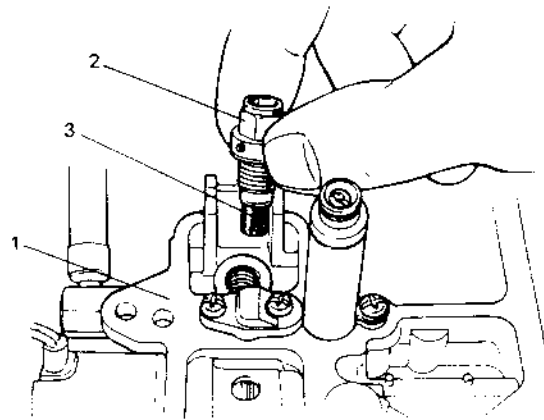
Never loosen 4 screws fixing element holder at this point.



- 1. Thermo element holder
- 2. Screw

Fig. 4-1-21

3) Remove float and needle valve from air horn and then needle valve seat and filter.



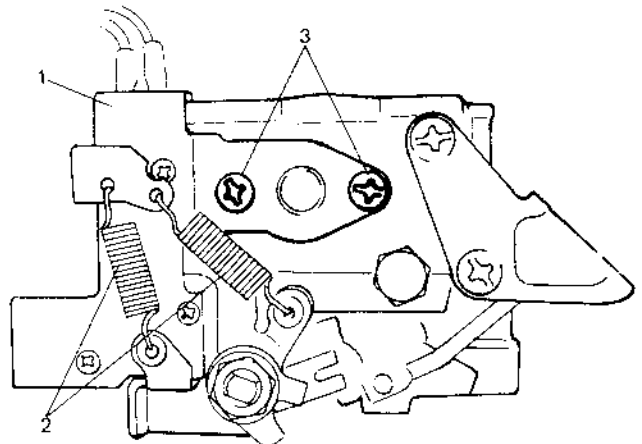
- 1. Air horn
- 2. Needle valve seat
- 3. Needle valve filter

Fig. 4-1-22 Needle valve seat and filter

4) Remove micro switch bracket after removing 2 springs and 2 screws indicated in below figure.

**NOTICE:**

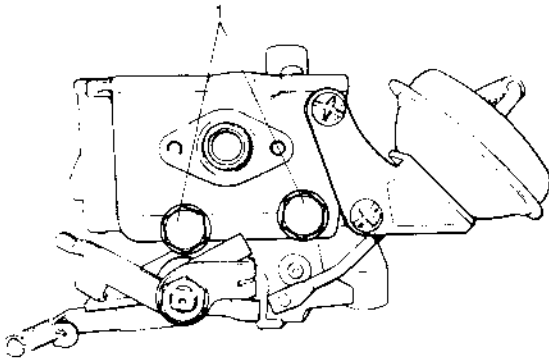
Don't remove micro switches from bracket.



- 1. Micro switch bracket
- 2. Spring
- 3. Screw

Fig. 4-1-23 Idle and wide open micro switches and bracket

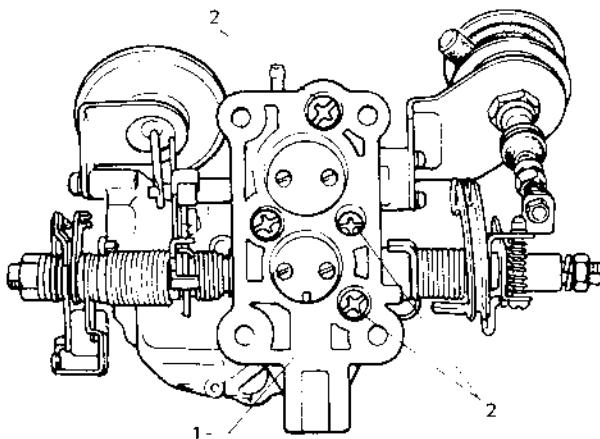
- Remove two drain plugs and then primary and secondary main jets in float chamber through plug's holes, using a negative screw driver.



1. Drain plug

Fig. 4-1-24 Drain plugs

- Remove throttle chamber from float chamber after removing four screws shown in below figure.



1. Throttle chamber  
2. Screw

Fig. 4-1-25 Throttle chamber

### Cleaning

- Wash below listed items in carburetor cleaner and then clean them by blowing compressed air.
  - All removable air jets and fuel jets, except mixture control solenoid valve jet.
  - Needle valve, valve seat and filter.

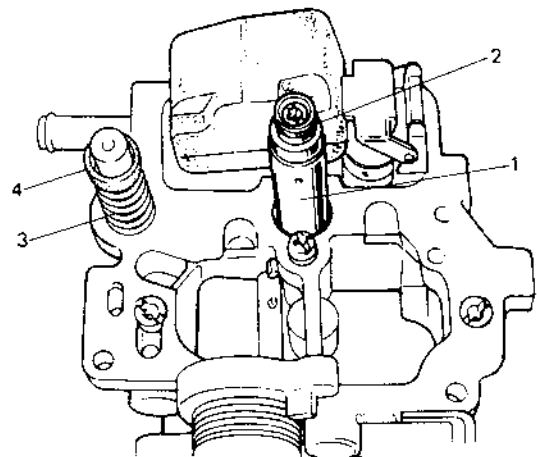
- Blow compressed air into all passages to clean.
- Clean bottom of float chamber.

### NOTICE:

- Don't immerse following parts in carburetor cleaner.
  - Micro switches (wide open switch and idle switch)
  - Switch vent solenoid
  - Fuel cut solenoid valve
  - Mixture control solenoid valve
  - Secondary diaphragm, choke piston and idle-up actuator
  - Parts made of rubber or resin and gasket
  - Thermo-wax (thermo element)
- Don't put drills or wires into fuel passages and metering jets for cleaning. It causes damages in passages and jets.
- If cleaning solvent contacts rubber or resin parts, be sure to blow off cleaning solvent by compressed air immediately.

### Inspection

- Check choke valve and throttle valves for smooth operation.
- Check rubber cup of pump piston and seal of mixture control solenoid valve for deterioration and damage. Refer to below figure.
- Check needle valve and valve seat for wear.



1. Mixture control solenoid valve  
2. Seal  
3. Spring  
4. Rubber cup

Fig. 4-1-26 Accelerator pump piston and mixture control solenoid valve

## Assembly

1) Install insulator to float chamber as shown in below figure.

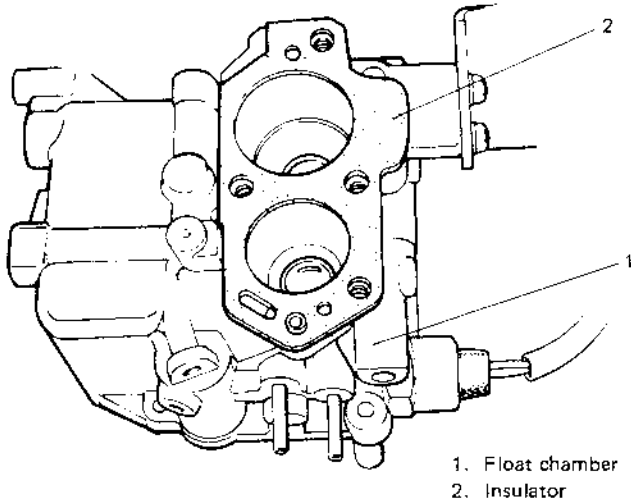


Fig. 4-1-27 Insulator installation

2) After attaching both ends of throttle lever return spring as shown in figure, install throttle chamber to float chamber. Hook throttle valve side end of return spring over the boss on float chamber as shown in below figure.

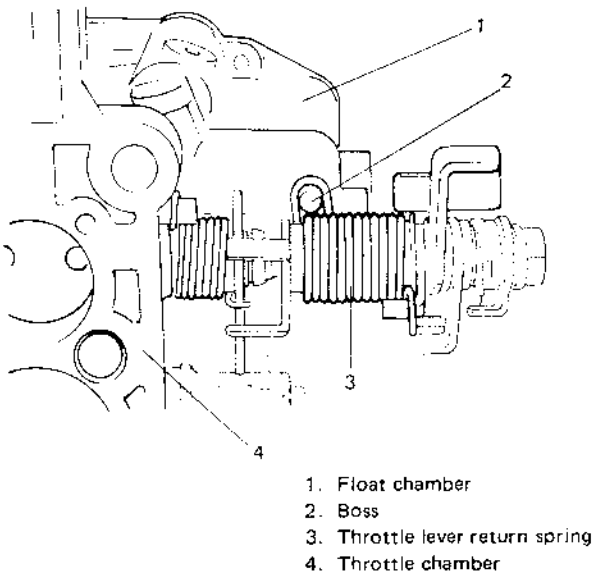


Fig. 4-1-28 Hooking throttle lever return spring

3) Two among four washers for throttle chamber securing screws are the toothed washers, and the other is spring one.

Install each washer to the throttle chamber as shown in below figure. Torque the four screws to specification.

Tightening torque for screws	4 – 7 N·m
	0.4 – 0.7 kg·m
	3 – 5 lb·ft

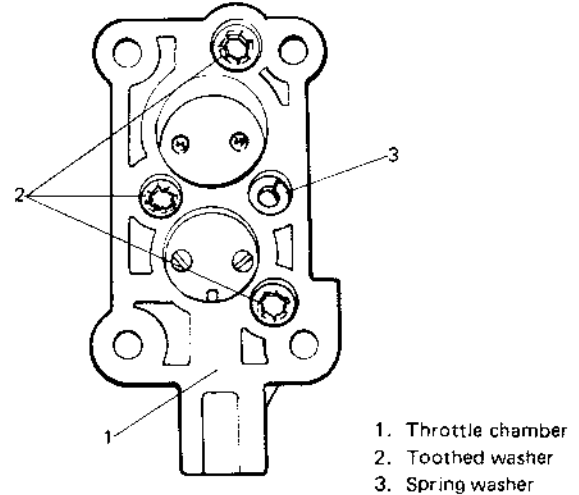


Fig. 4-1-29 Installing washers

4) Install primary and secondary main jets.

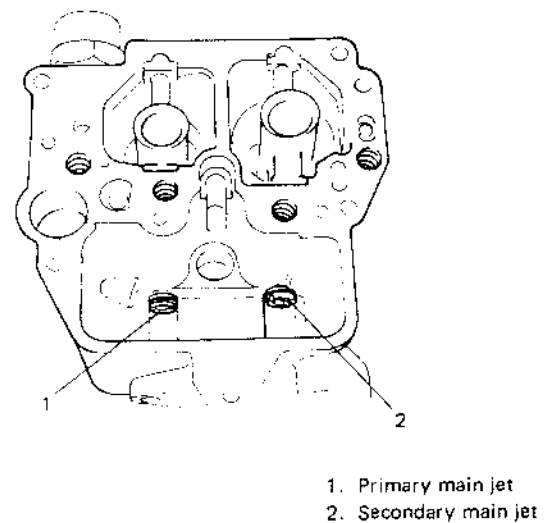


Fig. 4-1-30 Primary and secondary main jets



5) Install gaskets and drain plugs, after installing main jets.

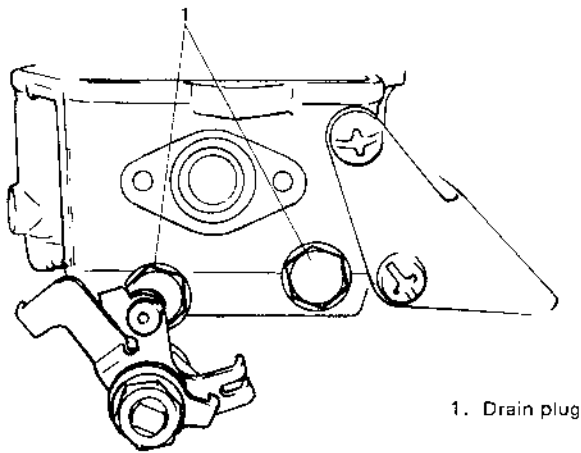


Fig. 4-1-31 Installing drain plugs

6) Install level gauge seal.

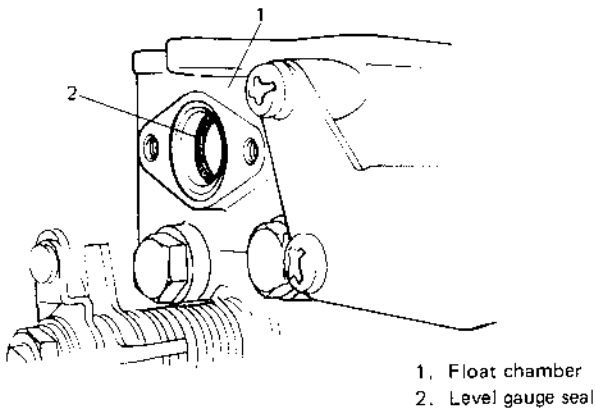


Fig. 4-1-32 Installing level gauge seal

7) Install micro switch bracket with micro switches and level gauge, and two springs as shown in below figure.

**NOTICE:**

- Don't remove micro switches (idle switch & wide open switch) from bracket.
- When bracket with micro switches has been removed from float chamber for any service and reinstalled after service work, make sure to check switches for operation and adjust if necessary. Check and adjustment for micro switches should be carried out with carburetor removed from intake manifold.

Refer to SECTION 5 "EMISSION CONTROL SYSTEM" for procedure to check and adjust micro switches.

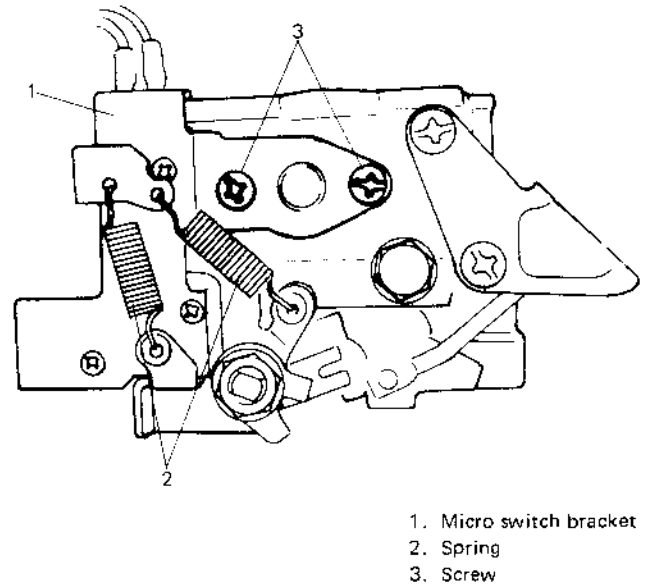


Fig. 4-1-33 Installing bracket and springs

8) Install jets and air bleeders to float chamber. Refer to Fig. 4-1-34 for their installation.

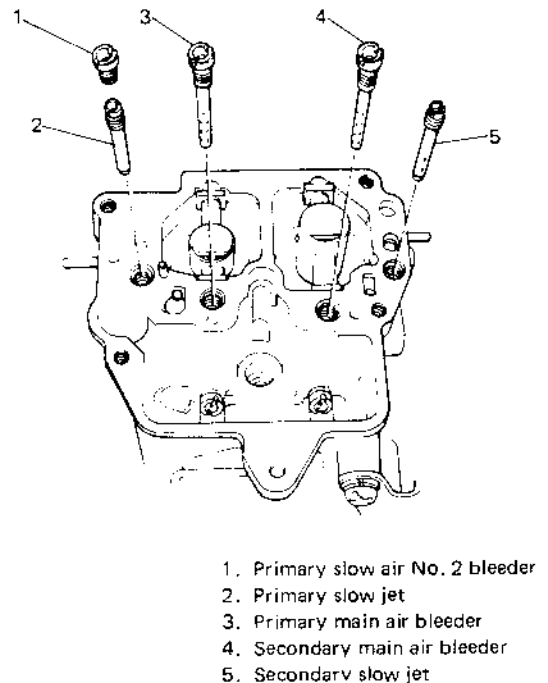


Fig. 4-1-34 Installing jets and air bleeders

9) Install balls, injector spring and weights to accelerator pump. Direct "U" bent end side of piston return spring downward as shown in below figure.

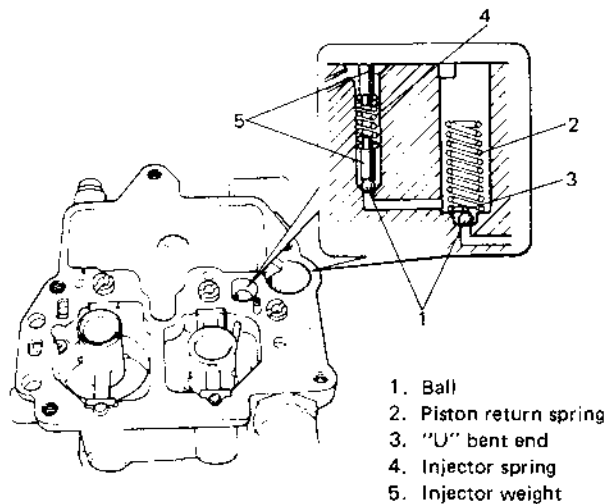
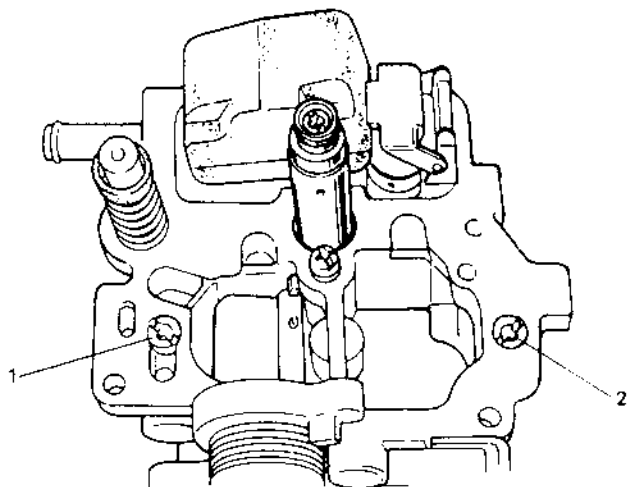


Fig. 4-1-35 Installing balls, injector spring and weights, and piston return spring

10) Install needle valve filter, valve seat, gasket, needle valve and float to air horn. After installing float, check for float level and adjust if necessary.

11) Install primary and secondary slow air bleeders to air horn.



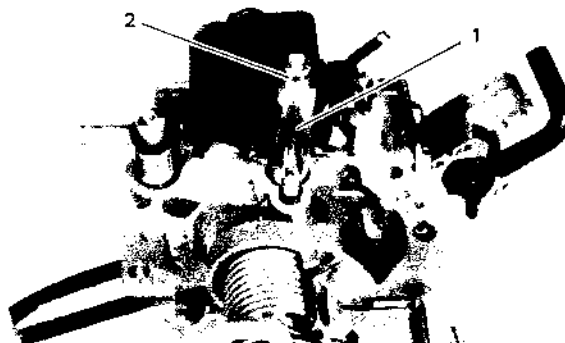
- 1. Primary slow air No. 1 bleeder
- 2. Secondary slow air bleeder

Fig. 4-1-36 Installing slow air bleeders

12) Be sure to apply silicone oil to mixture control solenoid valve seal before installing air horn to float chamber.

**NOTICE:**

Be sure to use silicone oil that will not affect rubber.



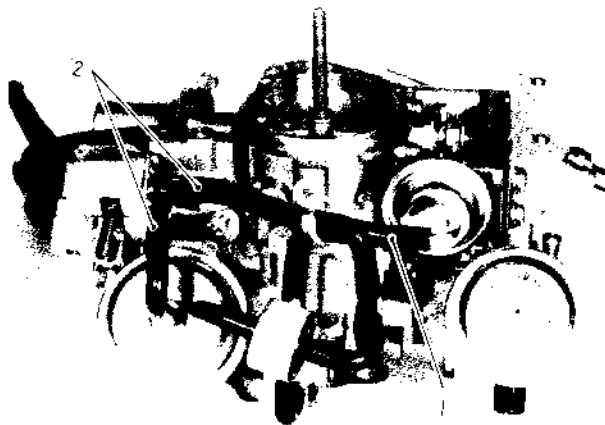
- 1. Mixture control solenoid valve
- 2. Seal

Fig. 4-1-37 Mixture control solenoid valve seal

13) Install air horn gasket to float chamber. Use new gasket.

14) Install air horn to float chamber. After installing acceleration pump lever to air horn, check lever for smooth operation.

15) Connect 3 hoses as shown below figure.



- 1. Choke piston hose
- 2. Secondary diaphragm hose

Fig. 4-1-38 Installing hoses

16) Clamp wire harness securely.



1. Clamp

Fig. 4-1-39

17) Remove the pin installed before disassembly (to lock fast idle cam).

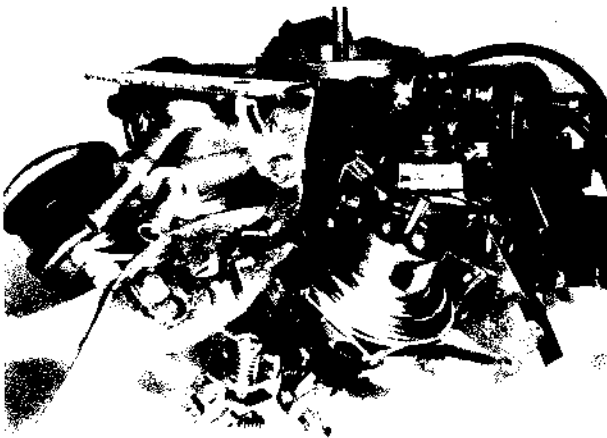


Fig. 4-1-40

## MAINTENANCE SERVICES

Before checking or adjusting the carburetor as the cause of poor engine performance or rough idle, check the followings for malconditions.

- Ignition system including distributor, timing, spark plugs and wires.
- Air cleaner including thermostatically controlled air cleaner system.
- Evaporative emission control system.
- PCV system.
- EGR valve.
- Engine compression.

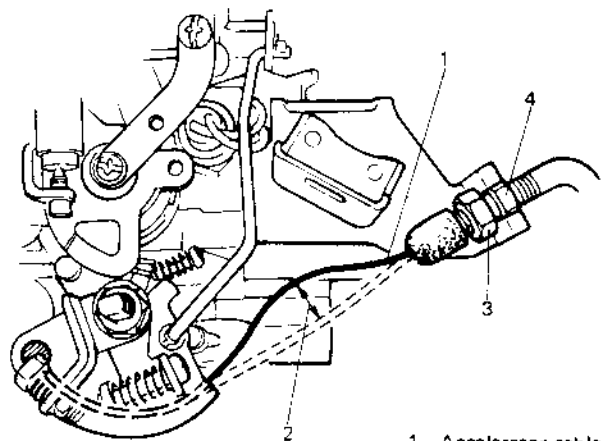
Also, check the intake manifold, carburetor and vacuum hoses for leakage.

### Accelerator Cable Adjustment

Check accelerator cable for play and adjust if necessary.

Cable play should be within the specifications. If out of specification, loosen lock nut and adjust by turning adjusting nut. Be sure to tighten lock nut securely after adjustment.

Condition	Cable play
When carburetor and coolant are cold;	10 – 15 mm (0.4 – 0.6 in.)
When carburetor and coolant are warm;	3 – 5 mm (0.12 – 0.20 in.)

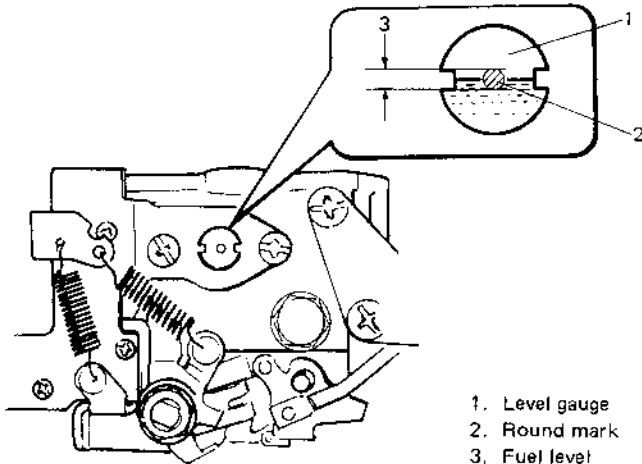


1. Accelerator cable
2. Cable play
3. Lock nut
4. Adjusting nut

Fig. 4-1-41 Accelerator cable play

## Float Adjustment

- 1) The fuel level in float chamber should be within round mark at the center of level gauge.



1. Level gauge
2. Round mark
3. Fuel level

Fig. 4-1-42 Fuel level

- 2) If the fuel level is not found within the round mark, check the float level and adjust it as follows:

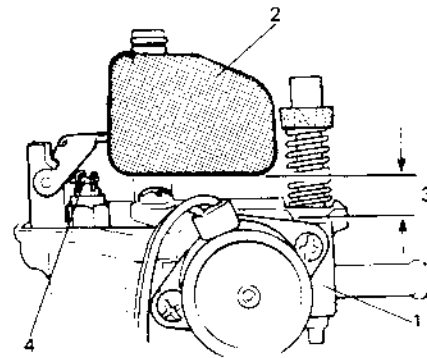
- a) Remove the air horn, and invert it.
- b) Measure the distance between the float and the gasketed surface of air horn. The measured distance is float level, and it should be the specification.

If the float level is out of specification, adjust it by bending the tongue up or down.

### NOTICE:

- This measurement should be made without a gasket on the air horn.
- Check float height with float weight applied to needle valve.
- As a gauge for checking float level, use something whose thickness measurement is the same as specified level measurement (such as a drill or M8 bolt) after confirming thickness with vernier calipers.

Float level specification	8 mm (0.31 in.)
---------------------------	--------------------

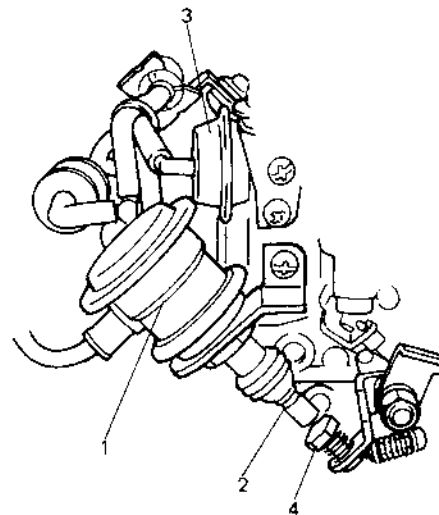


1. Air horn
2. Float
3. Float level
4. Tongue

Fig. 4-1-43 Float level

## Idle Up Adjustment

- 1) Warm up engine to normal operating temperature.
- 2) Check to be sure that engine idle speed is specification.
- 3) Check to ensure that idle-up actuator rod moves down (indicating that idle-up is at work) when small light, tail light, license light and side marker light are turned "ON".



1. Idle-up actuator
2. Idle-up actuator rod
3. Choke piston
4. Idle up adjusting screw

Fig. 4-1-44 Idle-up adjusting screw

- 4) With lights (head light) turned "ON", check engine rpm (idle-up speed). Be sure that heater fan, rear defogger (if equipped), and air conditioner (if equipped) are all turned "OFF".

Idle-up speed	900 – 1,000 r/min.
---------------	--------------------

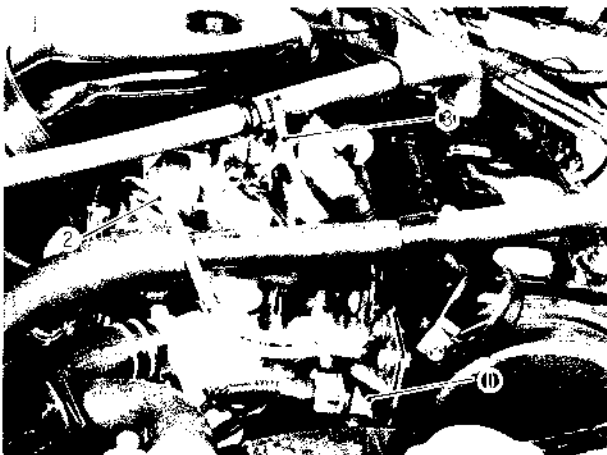
If idle-up speed is not within specification, adjust by turning adjusting screw.

- 5) After idle-up adjustment, check to ensure that idle-up adjusting screw moves as in step 3) when only heater fan is operated and then only rear defogger is operated (small light, tail light, side marker light and license light should be "OFF" in this cases).

If found faulty in step 3), check following parts individually according to each procedure.

#### [Checking TWSV]

- 1) Make sure that lighting switch, heater fan switch, rear defogger switch (if equipped) and air conditioner switch (if equipped) are all turned OFF.
- 2) Disconnect TWSV vacuum hoses from intake manifold and actuator.
- 3) With ignition switch at "OFF" position, by blowing air into hose disconnected from actuator, make sure there is no continuity between these hoses.
- 4) Turn lighting switch to ON position and by blowing air into the hose disconnected from actuator, make sure that there is continuity between hoses.



1. TWSV (Black)                      3. To actuator  
2. To intake manifold

Fig. 4-1-45

If defective in steps 3) and 4), replace TWSV or checking TWSV circuit.

#### [Checking TWSV circuit]

- 1) Warm up engine to normal operating temperature.
- 2) Stop engine and disconnect TWSV coupler.
- 3) Run engine at idle speed and connect voltmeter to coupler terminals disconnected. Check that voltmeter indicates 0V.
- 4) Check that voltmeter indicates about 12V under either of the following conditions.
  - When engine speed exceeds 2,000 r/min.
  - When lighting switch, heater fan switch or rear defogger switch (if equipped) is turned ON.

If defective in steps 3) and 4), the particular circuit is disconnected or in poor contact. Check the circuit for such condition. For detail, refer to item "CHECKING IDLE UP SIGNAL" in SECTION 5 "EMISSION CONTROL SYSTEM".

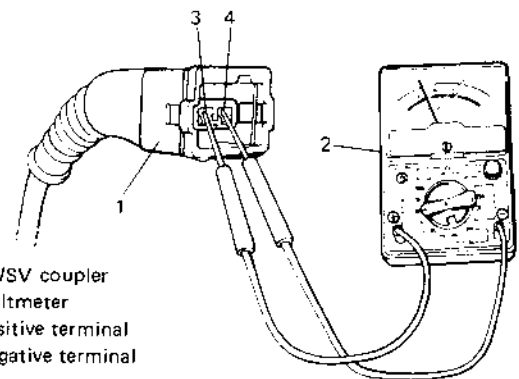
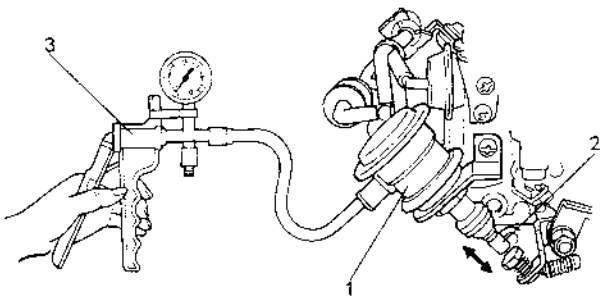


Fig. 4-1-46

#### [Checking actuator]

- 1) Disconnect hose from TWSV.
- 2) Connect special tool (vacuum pump gauge) to its hose.
- 3) Check that actuator rod moves smoothly and that it is held at the same position when about 40 cmHg vacuum is applied to actuator.

If rod doesn't move smoothly, or it isn't held at the same position, replace actuator.



1. Idle up actuator
2. Rod
3. Special tool (Vacuum pump gauge 09917-47910)

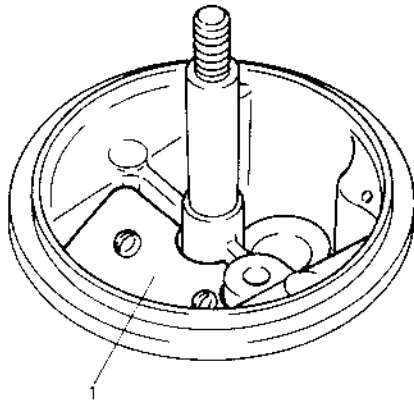
Fig. 4-1-47

### Choke Adjustment

Perform following check and adjustments with air intake case removed when engine is cold.

#### [Choke valve]

- 1) Check choke valve for smooth movement by pushing it with a finger.



1. Choke valve

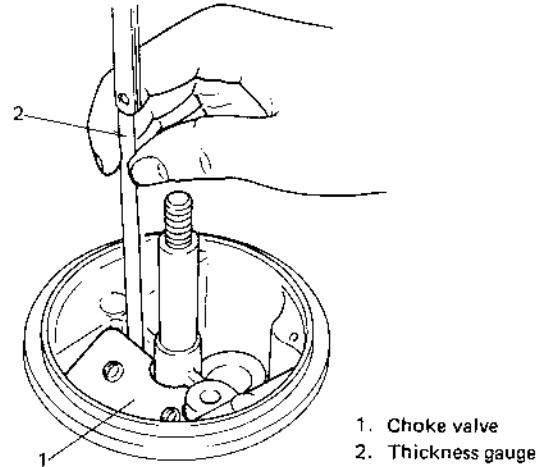
Fig. 4-1-48 Choke valve

- 2) Make sure that choke valve is closed almost completely when ambient temperature is below 25°C (77° F) and engine is cold.
- 3) Check to ensure that choke valve to carburetor bore clearance is within following specifications when engine is cool.

Ambient temperature	Clearance
25°C (77° F)	0.1 – 0.6 mm (0.004 – 0.023 in.)
40°C (104° F)	1.3 – 2.8 mm (0.05 – 0.11 in.)

#### NOTICE:

As ambient temperature or engine coolant temperature rises high, clearance increases.



1. Choke valve  
2. Thickness gauge

Fig. 4-1-49 Choke valve to carburetor bore clearance

- 4) If clearance is found excessively large or small in the above check, check strangler spring, choke piston and each link in choke system for smooth operation. Lubricate choke valve shaft and each link with spray lubricant if necessary.

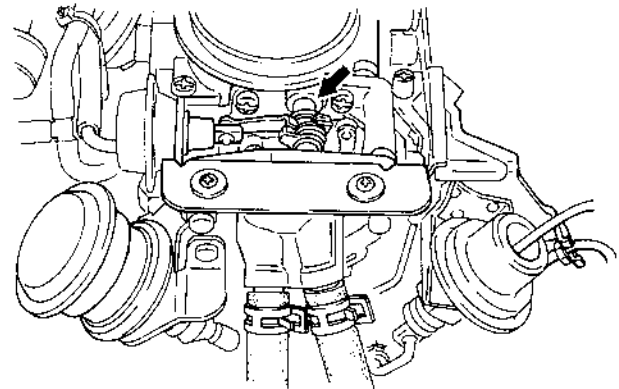


Fig. 4-1-50

5) If clearance is still out of specification even after lubrication in step 4), remove carburetor from intake manifold and remove idle-up actuator from carburetor.

Then, turn fast idle cam counterclockwise and insert a pin available into holes in cam and bracket to lock the cam.

In this state, bend choke lever shown in below figure up or down, with plier. Bending up causes choke valve to close, and down to open.



- 1. Fast idle cam
- 2. Bracket
- 3. Pin
- 4. Choke lever

Fig. 4-1-51 Choke lever

6) After installing air intake case, start engine again and warm it up fully.

7) Stop the engine when it is warmed up and remove air intake case again, and then check to ensure that choke valve is fully open.

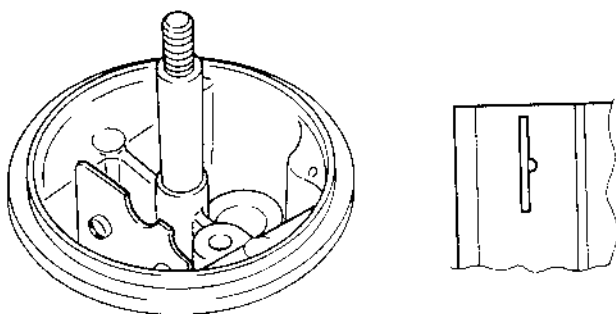


Fig. 4-1-52

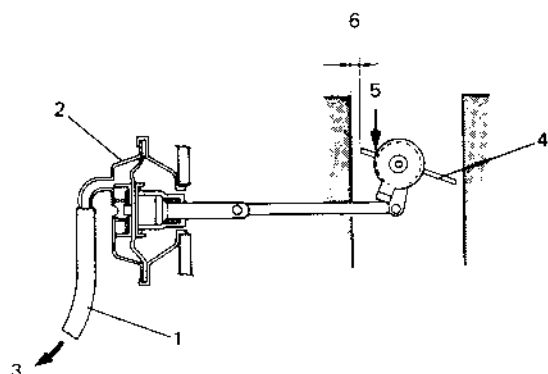
If choke valve doesn't open fully, defect lies in wax-element or its link system. Repair or replace defective part(s).

**[Choke piston]**

Check choke piston as follows.

- 1) Disconnect choke piston hose at throttle chamber.
- 2) With choke valve pushed down to its closing side lightly by finger, apply vacuum to choke piston hose with vacuum pump gauge, and check to ensure that choke valve to carburetor bore clearance is within the specification.

Choke valve to carburetor bore clearance	1.3 – 1.5 mm (0.05 – 0.06 in.)
--	-----------------------------------



- 1. Choke piston hose
- 2. Choke piston
- 3. Vacuum (Apply -30 ~ -50 cm Hg vacuum)
- 4. Choke valve
- 5. Push here lightly
- 6. Choke valve to carburetor bore clearance

Fig. 4-1-53 Checking choke piston

3) With vacuum applied as in step 2), move choke piston rod with small screw driver as shown and check to ensure that choke valve to carburetor bore clearance is within following specification.

Choke valve to carburetor bore clearance	3.2 – 3.7 mm (0.13 – 0.14 in.)
--	-----------------------------------

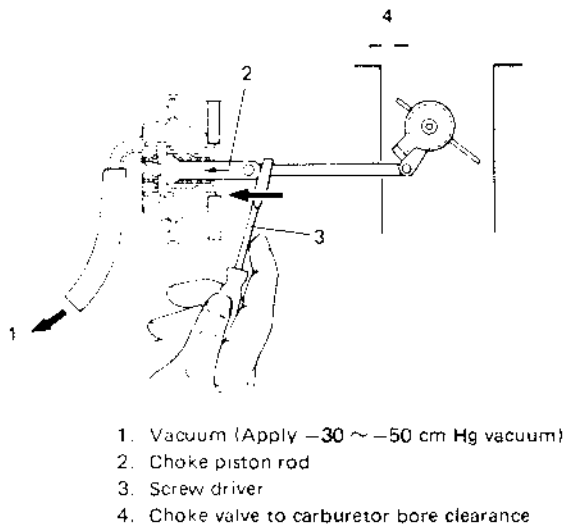


Fig. 4-1-54 Moving choke piston rod

### Fast Idle Adjustment

#### NOTICE:

Fast idle check and adjustment should be performed after making sure of the following.

- Ambient temperature is between 22°C and 28°C (71°F and 82°F).
- Idle up system (idle up speed) is normal.

Check and adjustment procedure is as follows.

- 1) Leave car at a place where ambient temperature is between 22°C and 28°C (71°F and 82°F), for over 4 hours.

#### NOTICE:

When carburetor is removed, leave carburetor at the place mentioned above for an hour and check as follows.

- 2) After leaving, make sure that the mark on cam and the center of cam follower are in alignment as shown in below figure.

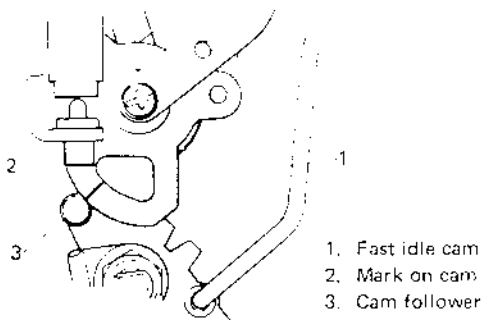
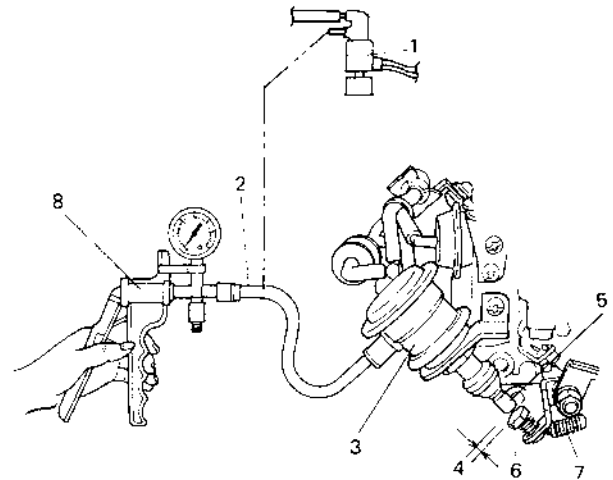


Fig. 4-1-55 Mark on cam and cam follower

- 3) Disconnect vacuum hose from TWSV and connect special tool (vacuum pump gauge) to its hose.



- With applying about 40 cmHg vacuum to actuator.
- 4) Check clearance between actuator rod and idle up adjusting screw.

Clearance "4" for fast idle	2.5 ~ 3.0 mm (0.10 ~ 0.12 in.)
--------------------------------	-----------------------------------

If clearance is out of specification, adjust it to specification with fast idle adjusting screw.

### Unloader Adjustment

Perform this check and adjustment when engine is cool.

- 1) Remove air intake case.
- 2) Make sure that choke valve is fully closed.
- 3) Fully open throttle valve and check choke valve to carburetor bore clearance to ensure it is within following specification.



4) If clearance is out of specification, adjust by bending the unloader arm indicated in below figure.

Choke valve to carburetor bore clearance	2.5 – 3.2 mm (0.10 – 0.12 in.)
--	-----------------------------------

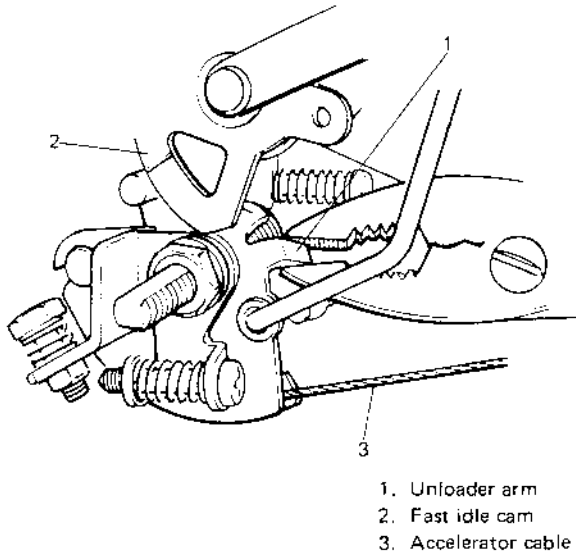
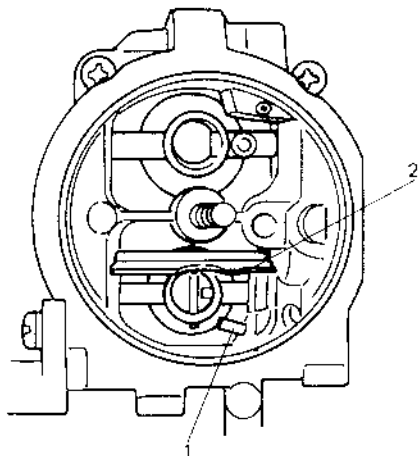


Fig. 4-1-57 Unloader lever arm

#### Checking Acceleration Pump

- 1) Remove air intake case.
- 2) Make sure that fuel comes out of pump discharge nozzle when accelerator pedal is depressed.

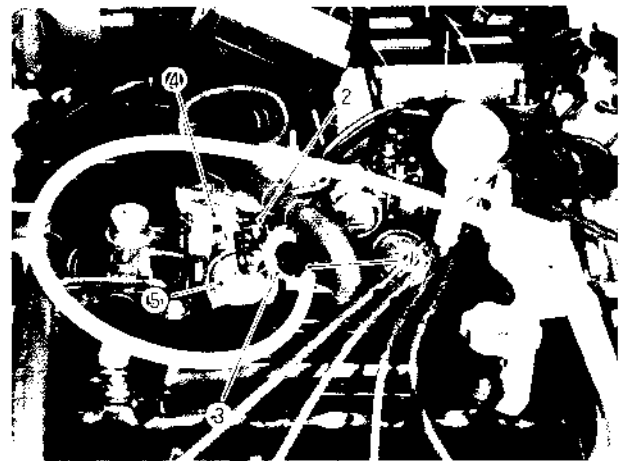


1. Pump discharge nozzle
2. Choke valve

Fig. 4-1-58 Pump discharge nozzle

#### Checking Secondary System

- 1) Remove air intake case.
- 2) Disconnect hose (1) from 3 way joint, and connect vacuum pump gauge.
- 3) Open primary throttle valve fully.
- 4) Check if secondary throttle valve opens smoothly and is held there when vacuum (10 cmHg) is applied to actuator.
- 5) Disconnect hose (2) from 3 way joint and connect vacuum pump gauge to its hose. Plug hose (1) with finger.
- 6) Turn ignition switch to "ON" position and open primary throttle valve fully. 5 or 6 seconds later, make the same check as in above step 4).



1. Hose
2. Hose
3. VTV
4. VSV
5. Actuator

Fig. 4-1-59

If check result in step 4) is not satisfactory, check VTV, and if that in step 6) is not satisfactory, check VSV.

If not satisfactory in either step 4) or 6) and both VTV and VSV are in good condition, replace actuator.

#### [VTV (Vacuum Transmitting Valve)]

Remove VTV. Use a vacuum pump gauge for VTV check. If pointer of vacuum pump gauge reacts as described below in each condition, VTV is in good condition.

With vacuum pump gauge set at Brown side of VTV, when pump is operated, pointer doesn't move (remains at zero position).

With vacuum pump gauge set at Black side of VTV, when pump is operated, pointer moves considerably but moves back to zero position as soon as pump operation is stopped.

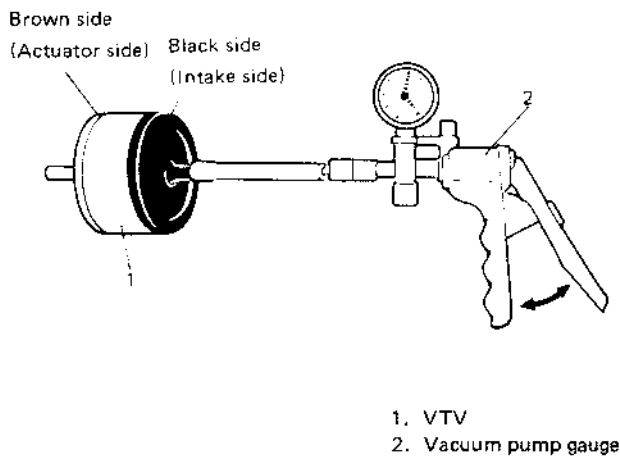


Fig. 4-1-60

Install VTV. Refer to Fig. 4-1-2 for installation.

#### [VSV (Vacuum Switching Valve)]

- 1) Disconnect VSV vacuum hoses from 3 way joint and secondary actuator and while blowing either hose, check that air doesn't come out of the other hose.
- 2) Turn on ignition switch and depress accelerator pedal fully. 5 or 6 seconds later, while blowing either vacuum hose, check that air comes out of the other hose.

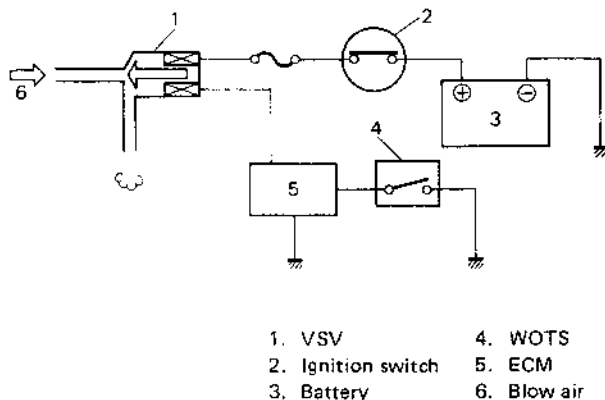


Fig. 4-1-61

If check results in steps 1) and 2) are not satisfactory, either replace VSV or check WOTS and its circuit referring to SECTION 5 "EMISSION CONTROL SYSTEM".

#### Idle Speed Adjustment

##### NOTICE:

Before starting engine, place transmission gear shift lever in "Neutral", and set parking brake and block drive wheels.

Before idle speed check and adjustment, make sure of the following.

- Lead wires and hoses of engine emission control systems are connected securely.
- Accelerator cable has some play, that is, it is not tight.
- All vacuum hoses are connected securely.
- Fuel level should be within round mark at the center of level gauge.
- Valve lash is checked and adjusted according to the maintenance schedule.
- Air cleaner has been properly installed and is in good condition.
- All accessories (wipers, heater, lights, etc) are out of service.
- Ignition timing is within specification.
- Idle up actuator is not operating when engine is running at idle speed.

##### NOTICE:

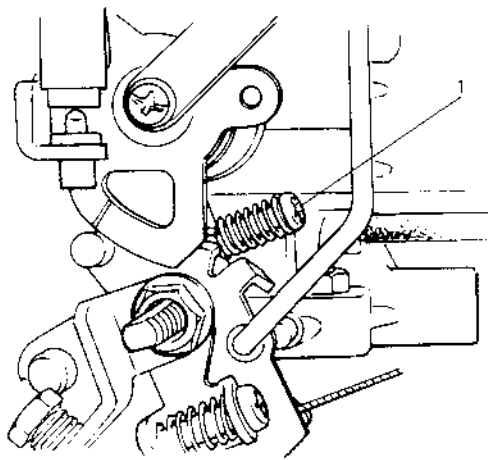
In areas above 4,000feet(1,220m) elevation (high altitude), idle up system will be normally in operation. Do not attempt to adjust the idle speed.

After above items are all confirmed, adjust idle speed as follows.

##### IMPORTANT:

Keep hands, tools, and clothing away from engine cooling fan to help prevent personal injury.

- 1) Warm up engine to normal operating temperature.
- 2) Check to ensure that idle speed is within 750 – 850 r/min (rpm).
- 3) If idle speed is not within specified range, adjust by turning idle speed adjusting screw. If idle speed can not be adjusted to the specification by turning the adjusting screw, it can be due to faulty return of throttle valve or some other reason. Determine cause and repair, and then adjust idle speed to specification.



1. Idle speed adjusting screw

Fig. 4-1-62 Idle speed adjusting screw

- 4) After idle speed adjustment, check idle-up for operation with lights (small light, tail light, side marker light and license light), heater fan and rear defogger (if equipped) turned "ON", only one at a time. Refer to item "Idle Up Adjustment". (p. 4-20).
- 5) Stop engine and check to ensure that accelerator cable play is within the specification as previously outlined. If play is out of specification, adjust it.

#### Idle Mixture Adjustment

The carburetor has been calibrated at the factory and should not normally need adjustment in the field. For this reason, the mixture adjustment should never be changed from the original factory setting. However, if during diagnosis, the check indicates the carburetor to be the cause of a driver performance complaint or emission failure, or the carburetor is overhauled or replaced, the idle mixture can be adjusted using the following procedure.

After adjustment, mixture adjusting screw pin must be installed.

#### Idle mixture adjustment procedure is as follows:

- 1) Remove carburetor from intake manifold following normal service procedure to gain access to mixture adjusting screw pin covering mixture adjusting screw.
- 2) Drive out mixture adjusting screw pin using about 4.5 mm (0.18 in) thick iron rod as shown below.

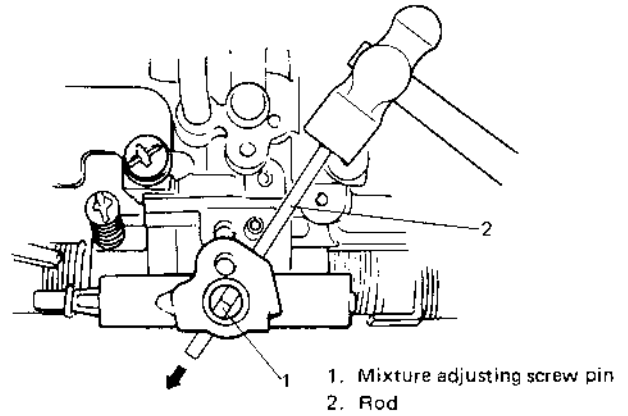
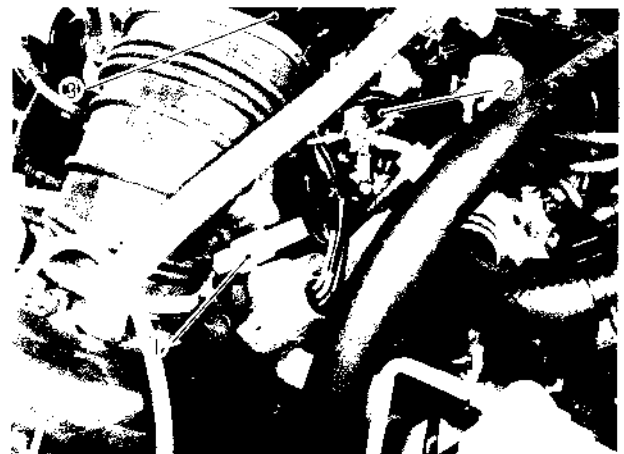


Fig. 4-1-63 Mixture adjusting screw pin

- 3) Reinstall carburetor following normal service procedures.

Connect emission control system hoses and lead wires. Make specified play on accelerator cable and refill cooling system.

- 4) Place transaxle gear shift lever in "Neutral", set parking brake and block drive wheels.
- 5) Start engine, and warm it up to normal operating temperature, stop engine.
- 6) Be sure to check the following before idle mixture adjustment.
  - Fuel level is within round mark at the center of level gauge.
  - Valve lash is checked and adjusted according to the maintenance schedule.
  - Air cleaner has been properly installed and is in good condition.
  - All accessories (wipers, heater, lights etc) are out of service.
  - Ignition timing is within specification.
  - Choke valve opens fully.
  - Idle-up actuator does not operate.
- 7) Set tachometer and CO tester.
- 8) Disconnect WOTS lead wire at coupler (Yellow coupler).

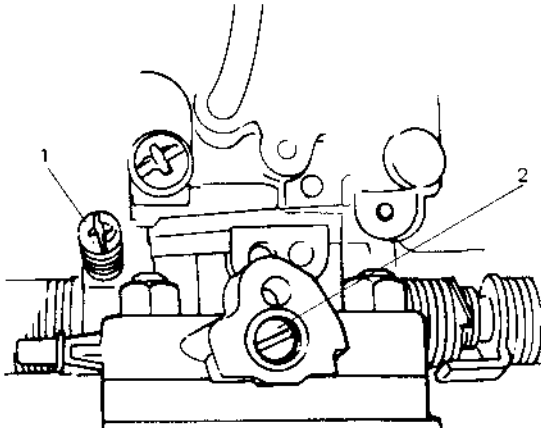


1. Yellow coupler 2. Carburetor 3. Air intake case

Fig. 4-1-64

- 9) Start engine and adjust idle speed to 850 – 950 r/min by turning idle speed adjusting screw.
- 10) Adjust CO concentration to 1.5 – 4.5% by either tightening or loosening idle mixture adjusting screw.
- 11) Readjust idle speed to 850 – 950 r/min by turning idle speed adjusting screw.

If CO concentration is not within 1.5 – 4.5% at this point, make adjustment again by repeating steps 9) and 10).



1. Idle speed adjusting screw
2. Idle mixture adjusting screw

Fig. 4-1-65 Mixture adjusting screw

- 12) Connect WOTS lead wire at the coupler.
- 13) Run engine at 2,000 r/min for 30 seconds and bring it to idling speed.
- 14) Check if engine idling speed and CO(%) meet the following values.

Engine idle speed	750 – 850 r/min
CO concentration	Less than 0.5%

- 15) If the above values are not obtained, repeat the adjustment described previously.
- 16) After adjustment, remove carburetor following normal service procedures and be sure to press-fit idle mixture adjusting screw pin. Install carburetor following normal service procedures.

## 4-2. AIR CLEANER

### GENERAL DESCRIPTION

In the air cleaner case, a dry-type air cleaner element is provided for filtering out dirt and dust from air being drawn into the engine for combustion.

A damaged element must be replaced with a new one, since it allows dust particles to enter the engine if used as it is. Such dust particles could cause wear to the engine inner parts and this further results in decreased output.

Also, the element must be cleaned periodically. Dusty and dirty element causes decrease in output and increase in fuel consumption. The dusty element even after cleaning should be replaced with a new one.

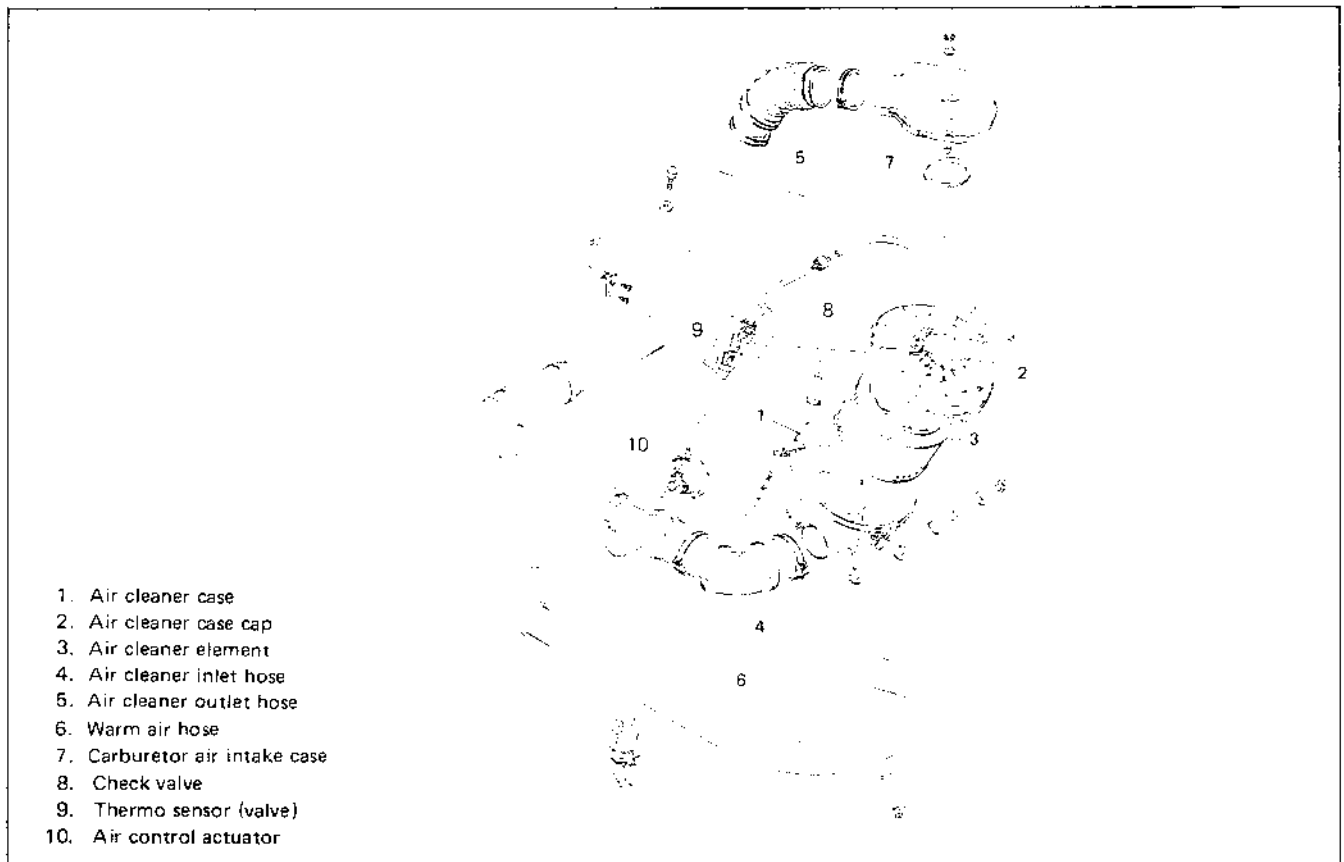


Fig. 4-2-1

### MAINTENANCE SERVICES

#### Air Cleaner Element

[Cleaning]

- 1) Remove air cleaner outlet hose and case cap.

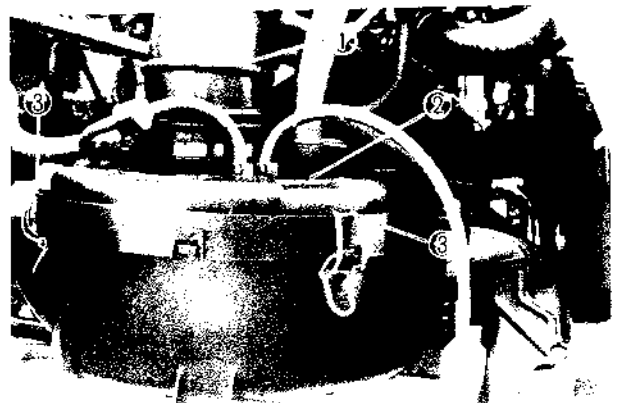


Fig. 4-2-2

- 2) Take out air cleaner element from air cleaner case and blow off dust with compressed air from inside of element.



Fig. 4-2-3

- 3) Install element and cap by fitting cap groove to case securely, and be sure to clamp cap.
- 4) Install air cleaner outlet hose.

[Replacement]

- 1) Remove air cleaner outlet hose and case cap.
- 2) Remove air cleaner element.



Fig. 4-2-4

- 3) Install new element and cap by fitting cap groove to case securely, and be sure to clamp cap.
- 4) Install air cleaner outlet hose.

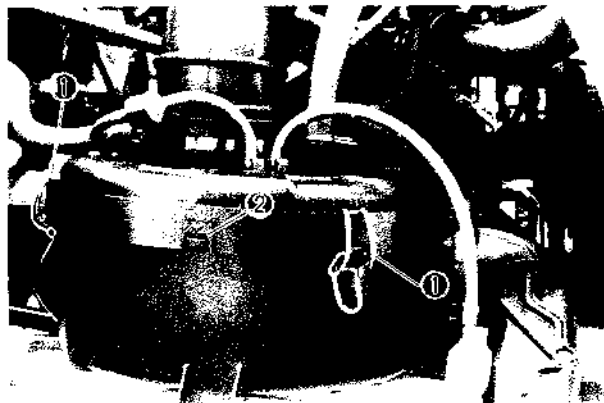


Fig. 4-2-4-1

1. Clamp
2. Groove

### 4.3. FUEL PUMP, FILTER AND LINES

#### GENERAL DESCRIPTION

The main components of the fuel system are fuel tank, fuel pump and fuel filter and it includes three lines; fuel feed line, fuel return line and fuel vapor line.

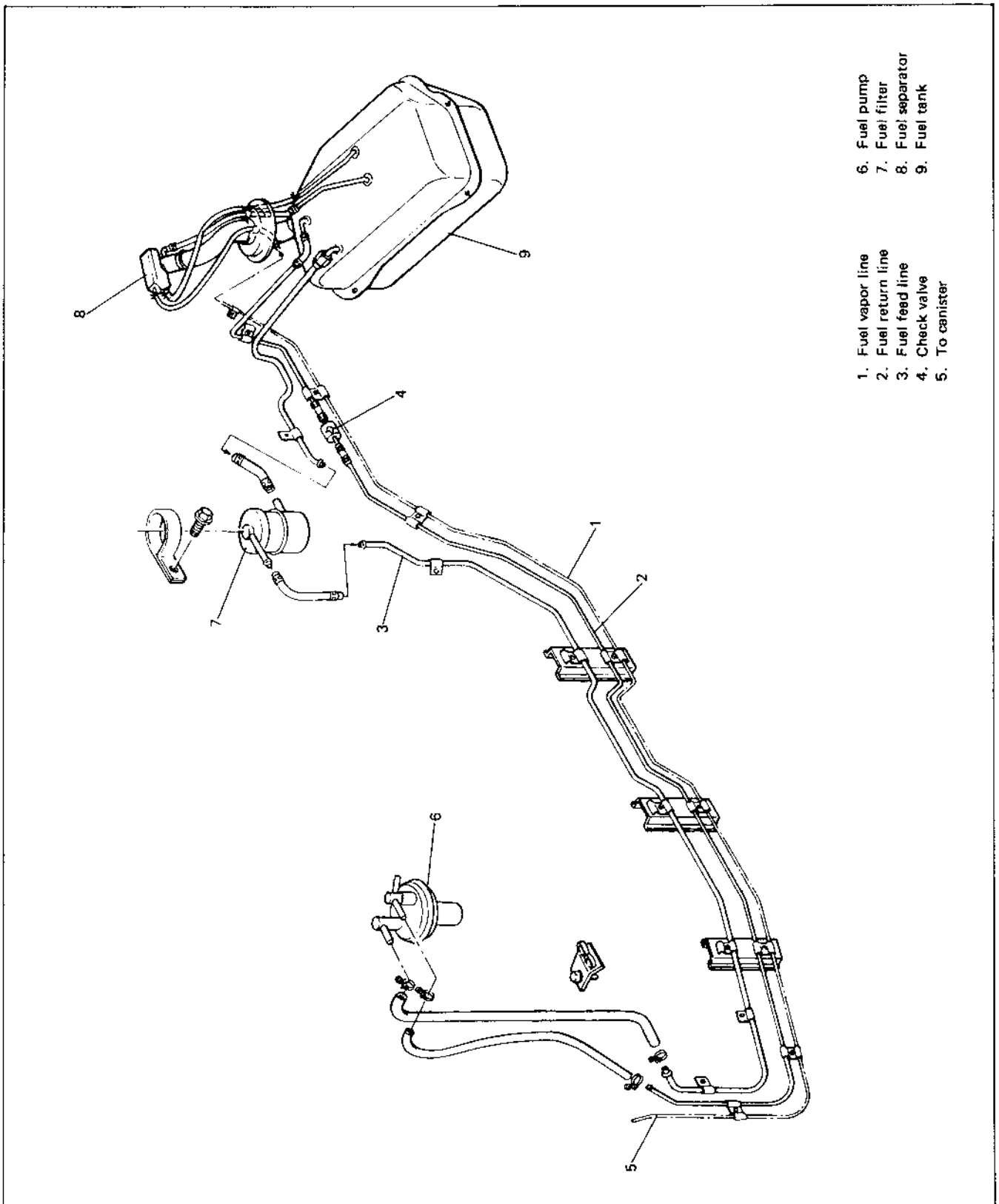


Fig. 4-2-5

## Fuel Pump

A mechanical fuel pump is mounted on the cylinder head.

The diaphragm in fuel pump is actuated from the cam on the engine camshaft, through a fuel pump rod and a rocker arm of fuel pump. A rocker arm rides on the cam through the fuel pump rod and moves the pump diaphragm up and the fuel pump feeds the fuel into carburetor. A fuel return circuit is provided in this pump in order to avoid "vapor lock". When the float chamber refuses to admit fuel, a slight pressure buildup occurs on the discharge side of the pump and this buildup causes the fuel to flow through the return circuit to the fuel tank. In other words, the fuel pump is kept in action as long as the engine is running, so that the constant flow of fuel through the pump keeps it cool.

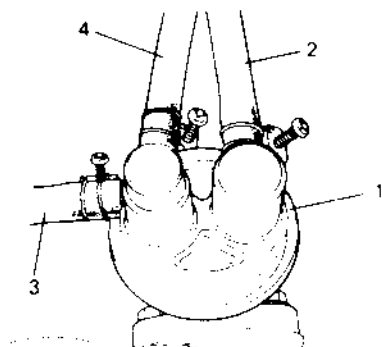


Fig. 4-2-6

1. Fuel pump
2. Inlet hose
3. Outlet hose
4. Return hose

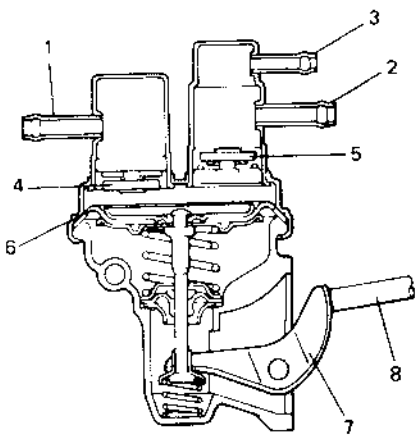


Fig. 4-2-7

1. Inlet
2. Outlet
3. Return tube
4. Inlet valve
5. Outlet valve
6. Diaphragm
7. Rocker arm
8. Fuel pump rod

## Fuel Filter

Fuel filter is located at the front part of fuel tank, inside the right-hand side of chassis.

Fuel enters the filter through its inlet hose and, after passing through filtering element, comes out of its outlet hose communicated to the fuel pump. This filter is not meant to be disassembled. It is of cartridge type, consisting of a filtering element in a plastic case.



Fig. 4-2-8

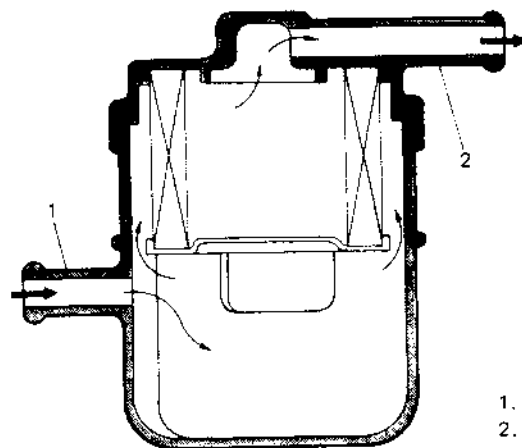


Fig. 4-2-9

1. Inlet
2. Outlet



## Fuel Filler Cap

The fuel tank filler neck has a pressure-vacuum cap.

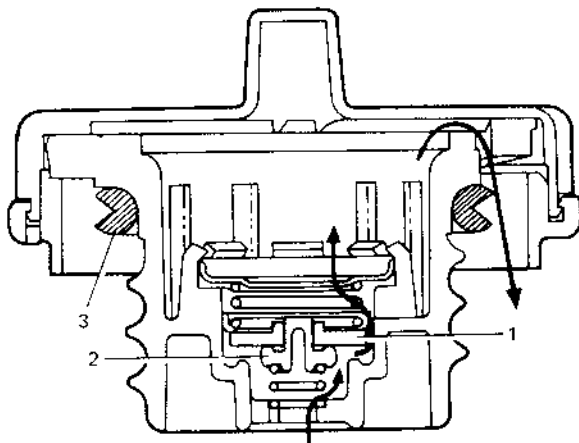
A ratchet tightening device on the threaded fuel filler cap reduces the chances of incorrect installation, which would prevent sealing fuel vapors.

After the gasket on fuel filler cap and the filler neck flange contact, the ratchet produces a loud clicking noise, indicating the seal has been set.

This cap has pressure relief valve and vacuum relief valve inside.

If the pressure of fuel vapor in fuel tank should exceed that for which fuel system is designed, the pressure relief valve opens to relieve the pressure.

The vacuum relief valve opens to relieve the vacuum created in fuel tank.



1. Pressure relief valve
2. Vacuum relief valve
3. Gasket

Fig. 4-2-10 Fuel filler cap cross-section

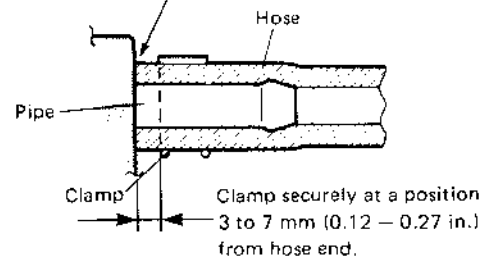
## REMOVAL AND INSTALLATION

### IMPORTANT:

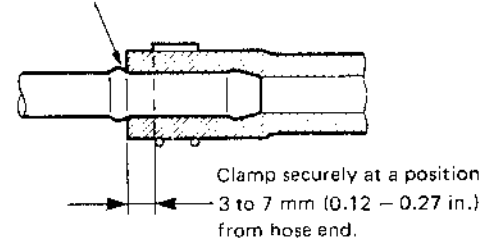
Before attempting service of any type on fuel system, the following cautions should be always observed.

- Disconnect negative cable at battery.
- DO NOT smoke, and place "NO SMOKING" signs near work area.
- Be sure to have CO<sub>2</sub> fire extinguisher handy.
- Wear safety glasses.
- To release fuel vapor pressure in fuel tank, remove fuel filler cap from fuel filler neck and then reinstall it. If pressure in fuel tank is not released beforehand, fuel in fuel tank may come out of fuel hoses due to the pressure when they are disconnected.
- Note that fuel hose connection varies with each type of pipe. Be sure to connect and clamp each hose correctly referring to the following.

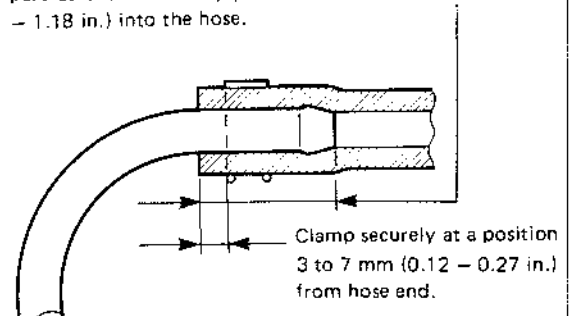
With following type pipe, fit hose as far as it reaches pipe joint as shown.



With following type pipe, fit hose as far as its peripheral projection as shown.



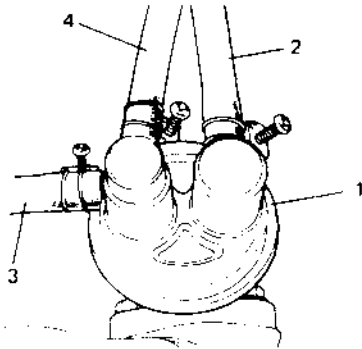
With following type pipe, fit hose as far as its bent part as shown or till pipe is about 20 to 30 mm (0.79 to 1.18 in.) into the hose.



## Fuel Pump

### [Removal]

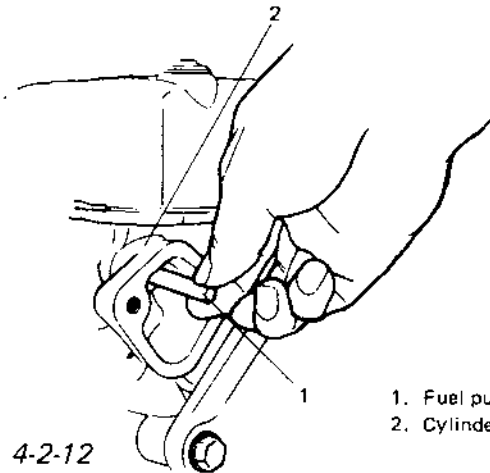
- 1) Disconnect negative cable from battery.
- 2) Remove fuel filler cap from fuel filler neck to release fuel vapor pressure in fuel tank. After releasing, reinstall the cap.
- 3) Disconnect fuel inlet, outlet and return hoses from fuel pump.



1. Fuel pump
2. Inlet hose
3. Outlet hose
4. Return hose

Fig. 4-2-11

- 4) Remove fuel pump from cylinder head.
- 5) Remove fuel pump rod from cylinder head.



1. Fuel pump rod
2. Cylinder head

Fig. 4-2-12

### [Installation]

Reverse removal procedure for installation using care for the following.

- After oiling it, install fuel pump rod to cylinder head.
- Use new fuel pump gasket.
- Make sure for proper hose connection.
- Upon completion of installation, start engine and check fuel hose or its joints for leaks.

## Fuel Filter

### [Removal]

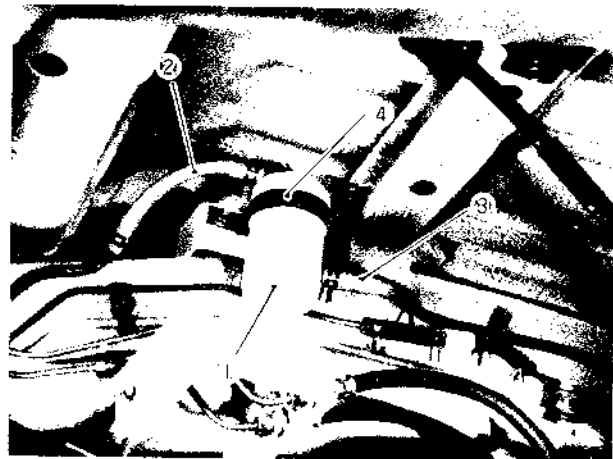
- 1) Disconnect negative cable from battery.
- 2) Remove fuel filler cap to release fuel vapor pressure in fuel tank. After releasing, reinstall the cap.
- 3) Disconnect inlet and outlet hoses from fuel filter.
- 4) Remove fuel filter with clamp.

### [Installation]

- 1) Install filter and clamp, and connect inlet and outlet hoses to fuel filter.

### NOTICE:

The top connection is for outlet hose, the lower one for inlet hose.



1. Fuel filter
2. To fuel pump
3. From fuel tank
4. Clamp

Fig. 4-2-13

- 2) Connect negative cable to battery.
- 3) After installation, start engine and check it for leaks.

## Fuel Tank

### [Removal]

- 1) Disconnect negative cable from battery.
- 2) Disconnect fuel level gauge lead wire.
- 3) To release the pressure in fuel tank, remove fuel filler cap and then, reinstall it.
- 4) Raise car on hoist.
- 5) Drain fuel by removing drain plug.
- 6) Remove filler hose protector.
- 7) Disconnect filler hose from fuel tank.
- 8) Disconnect fuel hoses and pipe from fuel tank.
- 9) Remove fuel tank.

[Fuel tank purging procedure]

**IMPORTANT:**

This purging procedure will NOT remove all fuel vapor. Do not attempt any repair on tank where heat or flame is required, as an explosion resulting in personal injury could occur.

The following procedure is used for purging the fuel tank.

- 1) After removing fuel tank, remove all hoses, fuel level gauge from fuel tank.
- 2) Drain all remaining fuel from tank.
- 3) Move tank to flushing area.
- 4) Fill tank with warm water or tap water, and agitate vigorously and drain. Repeat this washing until inside of tank is clean. Replace tank if inside is rusty.
- 5) Completely flush out remaining water after washing.

[Installation]

Reverse removal procedure for installation using care for the following.

Tightening torque for fuel tank	30 – 45 Nm (3.0 – 4.5 kg-m)
drain plug	(22.0 – 32.5 lb-ft)

Refer to Fig. 4-2-5 for piping and clamp positions.

- Make sure for correct hose-to-pipe connection.
- Clamp hoses securely.
- Upon completion of installation, start engine and check hose joints for leaks.

## MAINTENANCE SERVICES

### Fuel Lines

Visually inspect fuel lines and connections for evidence of fuel leakage, hose cracking, and damage. Make sure all clamps are secure.

Repair leaky joints, if any.

Replace hoses that are suspected of being cracked.

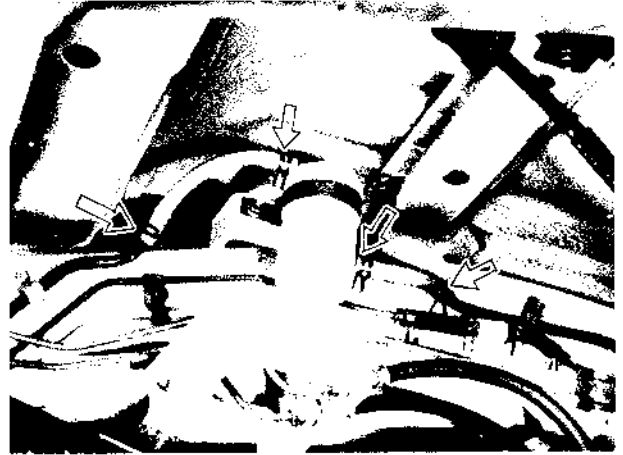


Fig. 4-2-14

### Fuel Filler (tank) Cap

Visually inspect gasket of fuel filler cap.

If it is damaged or deteriorated, replace filler cap with new one.

**NOTICE:**

If cap requires replacement, only a cap with the same features should be used. Failure to use correct cap can result in a serious malfunction of the system.

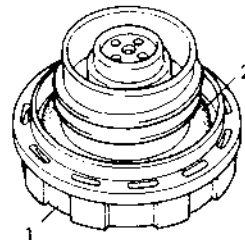


Fig. 4-2-15

1. Fuel filler cap
2. Fuel filler cap gasket

### Fuel Filter

As said before, this filter does not permit disassembly: it is to be replaced with a new one periodically.

Replace fuel filter referring to previous item of "Fuel Filter Removal and Installation".

**WARNING:**

This servicing must be performed in a well ventilated area and away from any open flames (such as gas hot water heaters).

## 4-4. ACCELERATOR PEDAL

### PRECAUTIONS TO BE TAKEN IN ACCELERATOR PEDAL INSTALLATION

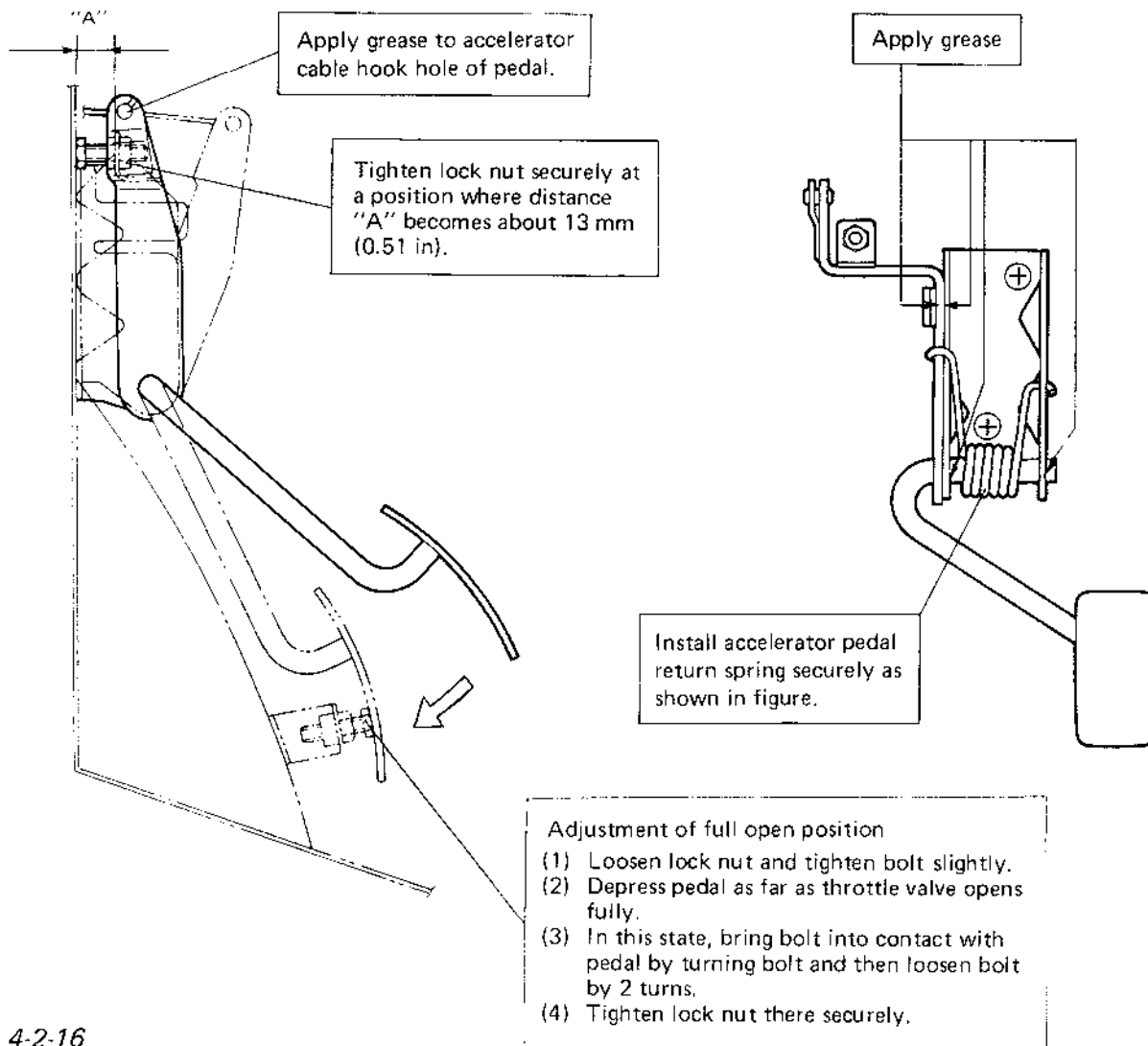


Fig. 4-2-16

# SECTION 5

## EMISSION CONTROL SYSTEM

### CONTENTS

5-1.	GENERAL DESCRIPTION .....	5-4
	POSITIVE CRANKCASE VENTILATION (PCV) SYSTEM .....	5-5
	THERMOSTATICALLY CONTROLLED AIR CLEANER (TCAC) SYSTEM .....	5-6
	EVAPORATIVE EMISSION CONTROL SYSTEM .....	5-7
	HOT IDLE COMPENSATOR (HIC) .....	5-8
	DECELERATION MIXTURE CONTROL SYSTEM .....	5-9
	COMPUTER CONTROLLED EMISSION CONTROL SYSTEM .....	5-10
	BOWL VENTILATION SYSTEM .....	5-12
	FUEL CUT SYSTEM .....	5-13
	EXHAUST GAS RECIRCULATION (EGR) SYSTEM .....	5-14
5-2.	DIAGNOSIS .....	5-15
5-3.	MAINTENANCE SERVICE .....	5-18
	GENERAL .....	5-18
	PCV SYSTEM .....	5-18
	TCAC SYSTEM .....	5-19
	EVAPORATIVE EMISSION CONTROL SYSTEM .....	5-20
	HOT IDLE COMPENSATOR (HIC) .....	5-21
	DECELERATION MIXTURE CONTROL SYSTEM .....	5-21
	FEED BACK SYSTEM .....	5-22
	SWITCH VENT SOLENOID .....	5-36
	FUEL CUT SYSTEM .....	5-36
	EGR SYSTEM .....	5-37

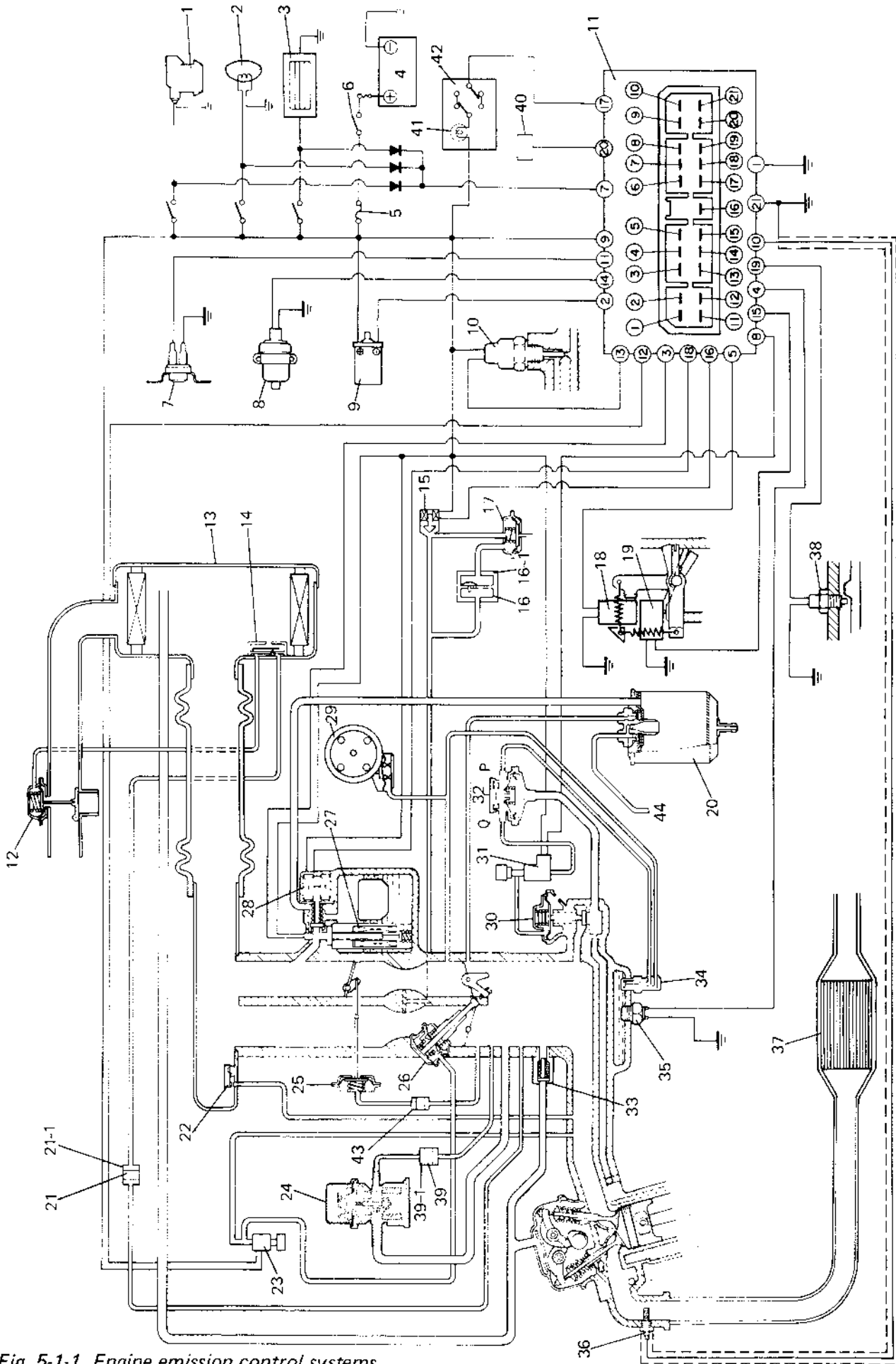


Fig. 5-1-1 Engine emission control systems

- |   |  |                                      |
|---|--|--------------------------------------|
| 1. Heater fan                               | 21. Check valve (black)                        | 39-1. Gray side                      |
| 2. Small, Tail, Side marker & license light | 21-1. Orange side                              | 40. Check connector                  |
| 3. Rear defogger                            | 22. Hot idle compensator (HIC)                 | 41. "SENSOR" light                   |
| 4. Battery                                  | 23. Three way solenoid valve (TWSV)            | 42. Mileage sensor and Cancel switch |
| 5. Fuse (circuit fuse)                      | 24. Mixture control valve (MCV)                | 43. Delay valve (orifice)            |
| 6. Ignition switch                          | 25. Choke piston                               | 44. To fuel tank                     |
| 7. Thermal engine room switch               | 26. Idle up actuator                           |                                      |
| 8. High altitude compensator (HAC)          | 27. Mixture control solenoid valve (MCSV)      |                                      |
| 9. Ignition coil                            | 28. Vent solenoid valve                        |                                      |
| 10. Fuel cut solenoid                       | 29. Distributor                                |                                      |
| 11. Electronic control module (ECM)         | 30. Exhaust gas recirculation (EGR) valve      |                                      |
| 12. Air control actuator                    | 31. Three way solenoid valve (TWSV)            |                                      |
| 13. Air cleaner                             | 32. EGR modulator                              |                                      |
| 14. Thermo sensor                           | 33. Positive crankcase ventilation (PCV) valve |                                      |
| 15. Vacuum switching valve (VSV)            | 34. Bi-metal vacuum switching valve (BVSV)     |                                      |
| 16. Vacuum transmitting valve (VTV)         | 35. Thermal switch                             |                                      |
| 16-1. Brown side                            | 36. Oxygen sensor                              |                                      |
| 17. Secondary throttle valve actuator       | 37. Three way catalyst                         |                                      |
| 18. Wide open micro switch                  | 38. Fifth switch                               |                                      |
| 19. Idle micro switch                       | 39. Jet (colorless)                            |                                      |
| 20. Vapor storage canister                  |  |                                      |

## 5-1. GENERAL DESCRIPTION

### VEHICLE EMISSION CONTROL INFORMATION LABEL

The Vehicle Emission Control Information Label is located under hood. The label contains important emission specifications and setting procedures, as well as a vacuum hose schematic with emission components identified.

When servicing the engine or emission systems, the Vehicle Emission Control Information Label should be checked for up-to-date information.

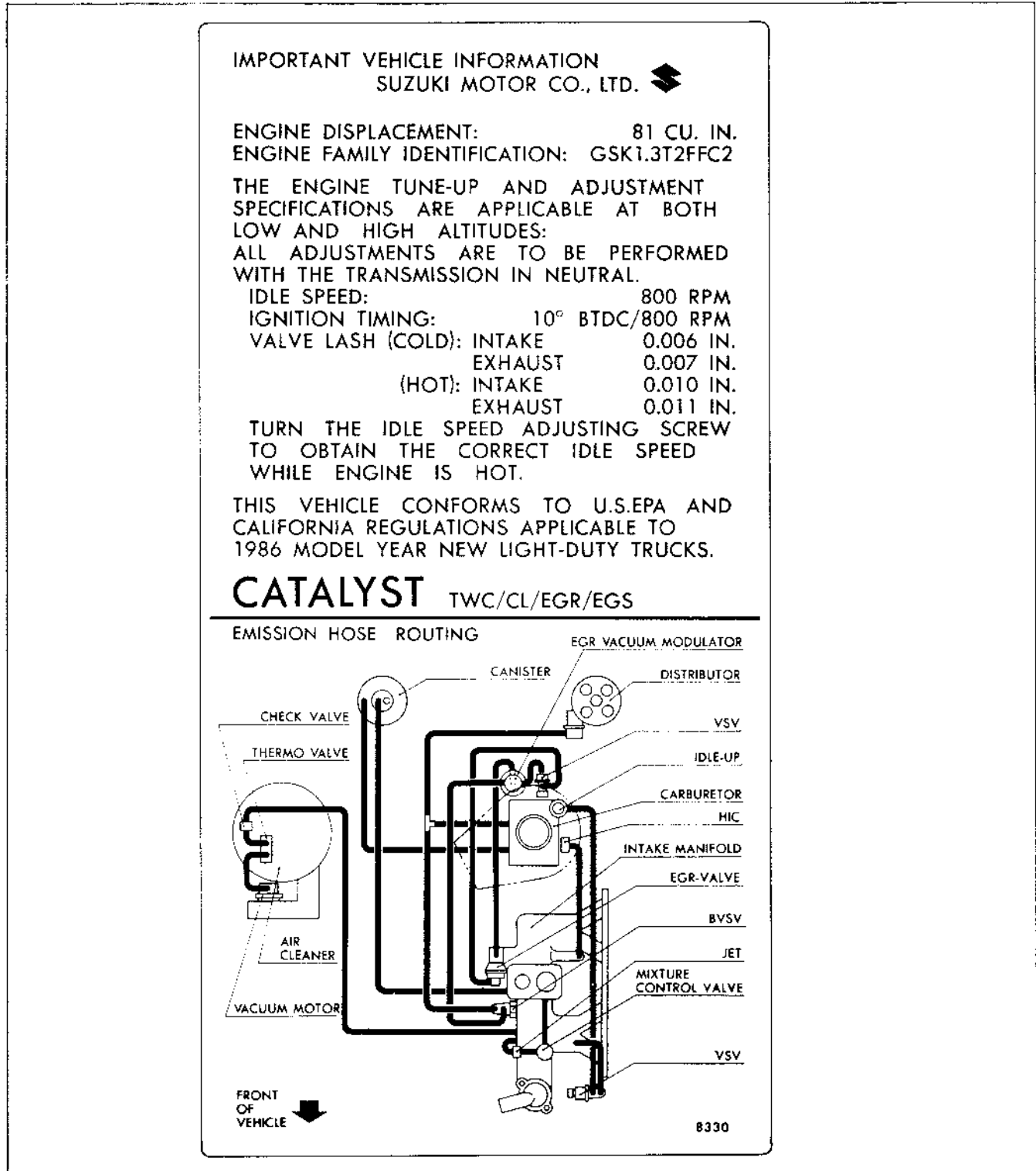


Fig. 5-1-2 Vehicle emission control information label (Sample)



## POSITIVE CRANKCASE VENTILATION (PCV) SYSTEM

(Blow-by gas recycling system)

The blow-by gas in the crankcase flows through the passage in the cylinder block into the cylinder head. The oil particles are separated from the blow-by gas by the oil separating unit in the cylinder head cover. The gas is then returned together with the fresh air coming from the air cleaner through the PCV valve into the intake manifold for recombustion.

When the vacuum in the intake manifold is low (when the opening of the throttle valve is large), the PCV valve is wide open due to its spring force. Thus a large amount of the blow-by gas is drawn into the intake manifold.

On the other hand, when the vacuum in the manifold is high, the PCV valve opening is limited due to the high vacuum. Thus the amount of the blow-by gas drawn into the intake manifold is small.

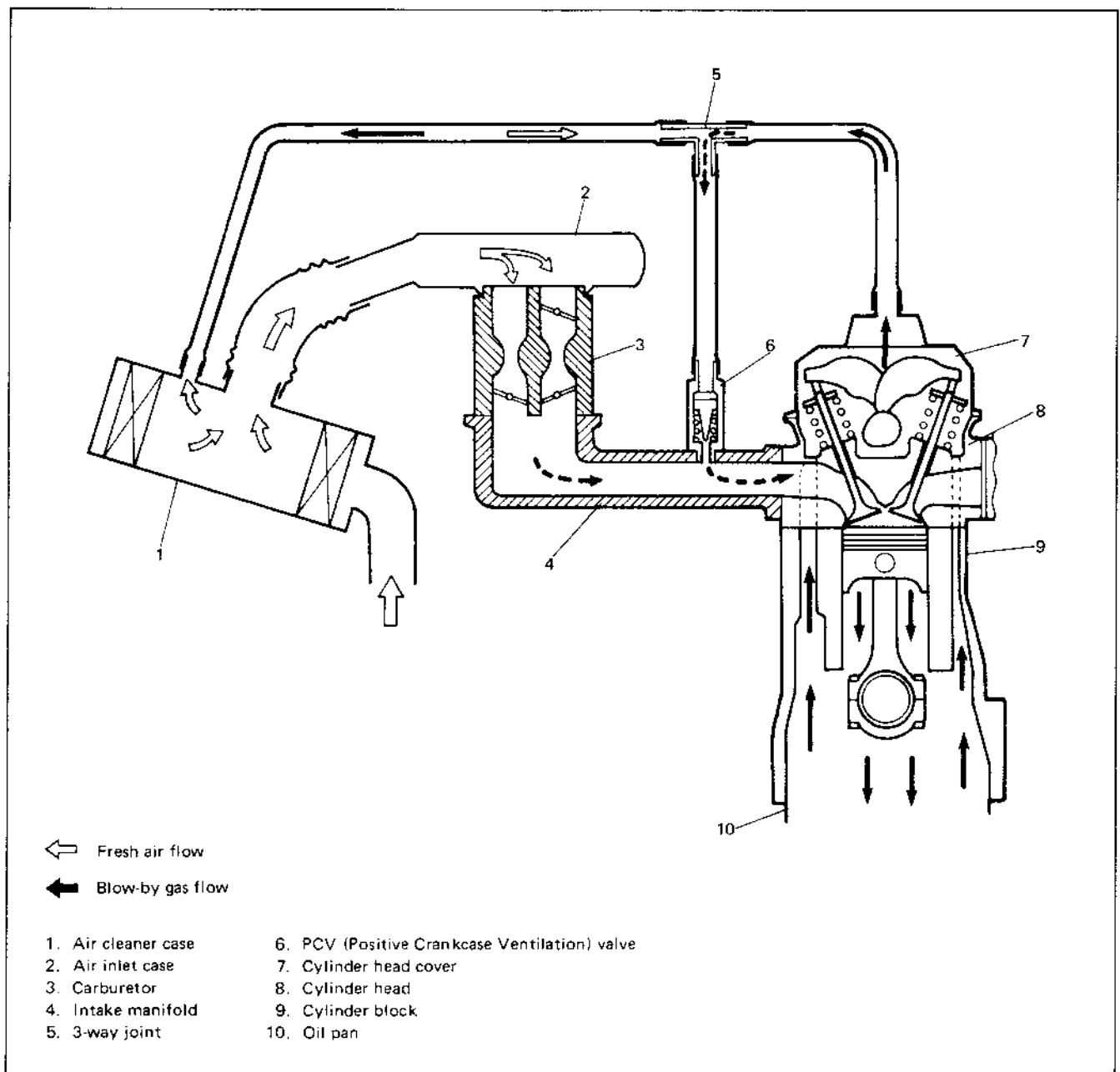


Fig. 5-1-3 PCV system operation

## THERMOSTATICALLY CONTROLLED AIR CLEANER (TCAC) SYSTEM

This system helps to improve fuel vaporization by controlling the temperature of the intake air almost at a constant level automatically regardless of driving conditions and outside temperature, to distribute the mixture to each cylinder evenly and to stabilize the air/fuel mixture ratio.

It consists of the thermo sensor (thermo valve) and the Air Control Actuator (ACA). The thermo sensor located in the air cleaner case senses the temperature of the intake air and controls the vacuum line by opening and closing its passage to the ACA. According to this opening and closing operation, the vacuum in the intake manifold actuates the damper through the diaphragm in the ACA. For the warm air, the air is warmed up in the exhaust manifold cover and for the cold air, the outside air is drawn through the fresh air passage and both enter the air cleaner.

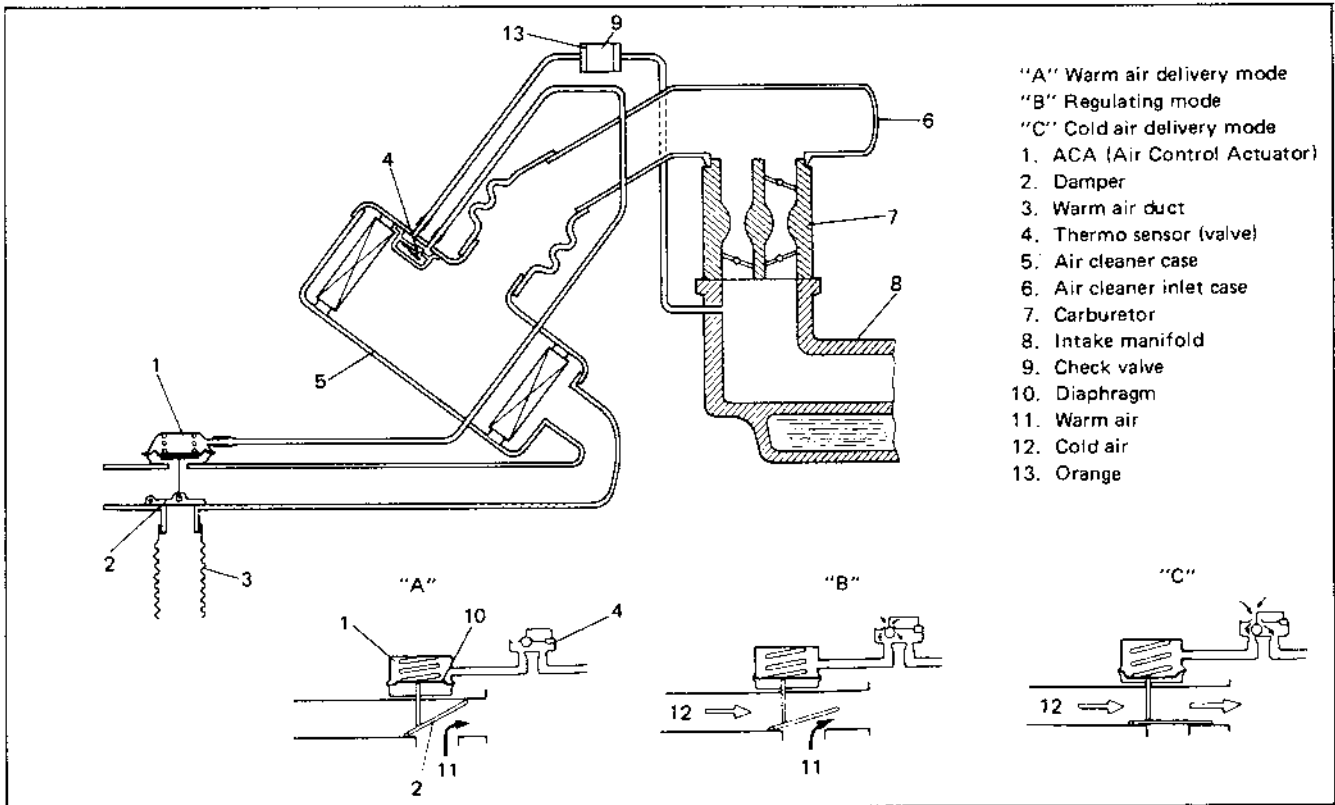


Fig. 5-1-4 TCAC system operation

### System Operation

When engine is started in cold weather, the thermo valve is closed because the temperature of the intake air in the air cleaner is low. Therefore, the vacuum is transmitted to the ACA diaphragm, which then pulls up the damper linked to the diaphragm to open the warm air duct fully. As the engine is warmed up, the temperature of the intake air coming into the air cleaner from the warm air duct rises and the thermo valve starts opening. As a result, the vacuum transmitted to the ACA diaphragm decreases, and the damper pushed down by the spring force lessens the warm air duct opening. In this state, warm air and cold air are mixed together and enters the air cleaner.

When the engine is operating at high rpm and under high load condition, the temperature of the air coming from the warm air duct rises very high, causing the thermo valve opening to become even larger and the damper opening smaller. That is, the amount of the warm air coming from the warm air hose decreases and the cold air amount increases.

In this way, this system serves to maintain the temperature of the intake air going into the carburetor almost at a constant level.

## EVAPORATIVE EMISSION CONTROL SYSTEM

An evaporative emission control system is used to prevent emission of fuel vapors from the vehicle fuel system.

The system allows evaporating fuel vapors to be stored, when the engine is not running.

This is accomplished by venting the fuel tank and carburetor float chamber through a vapor storage canister containing activated charcoal.

The major system components are vapor storage canister, vent solenoid, and liquid vapor separator.

The fuel vapor from the fuel tank is led into the canister and stored there when the engine is not running. The fuel vapor from the carburetor float chamber is also stored in the canister when the ignition switch is "OFF".

When engine runs, the fuel vapor stored in the canister is drawn into the intake manifold together with fresh air.

For vent solenoid valve operation, refer to item of "BOWL VENTILATION SYSTEM."

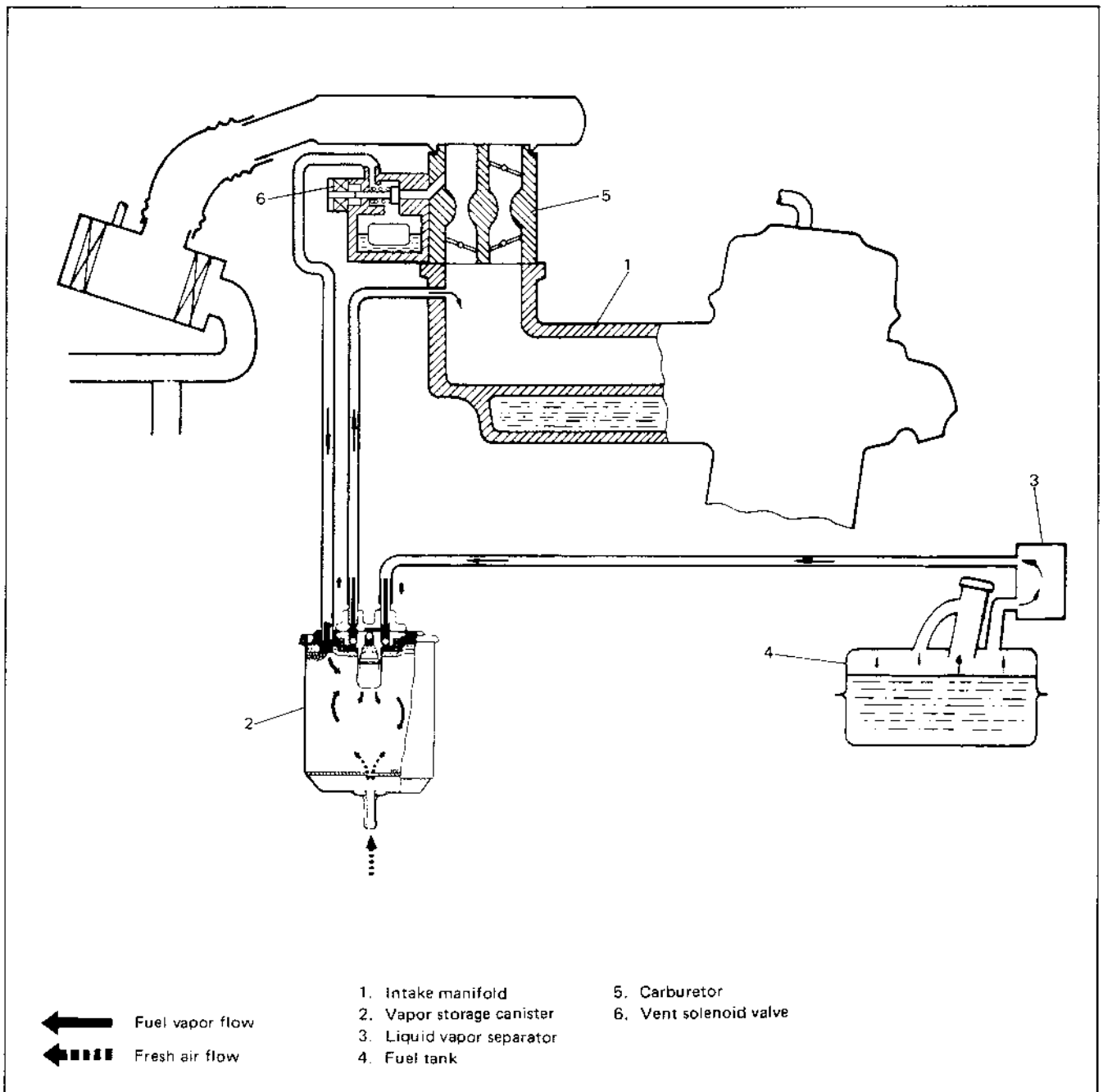


Fig. 5-1-5 Evaporative emission control system

## HOT IDLE COMPENSATOR (HIC)

HIC attached to the air intake case serves to provide the optimum air/fuel mixture during hot idle so as to ensure stable idle speed.

HIC has a bimetal which warps as the heat transferred to it rises higher than about  $55^{\circ}\text{C}$  ( $131^{\circ}\text{F}$ ). Caused by this, the valve in HIC starts to open and it reaches to the full open state at about  $70^{\circ}\text{C}$  ( $158^{\circ}\text{F}$ ).

While the engine at idle, the throttle valve is closed and the vacuum in the intake manifold stays high. As the HIC valve opens in this state, the air from the air cleaner is drawn through the HIC valve into the intake manifold to prevent the air/fuel mixture getting richer during hot idle, thus maintaining a stable idle speed.

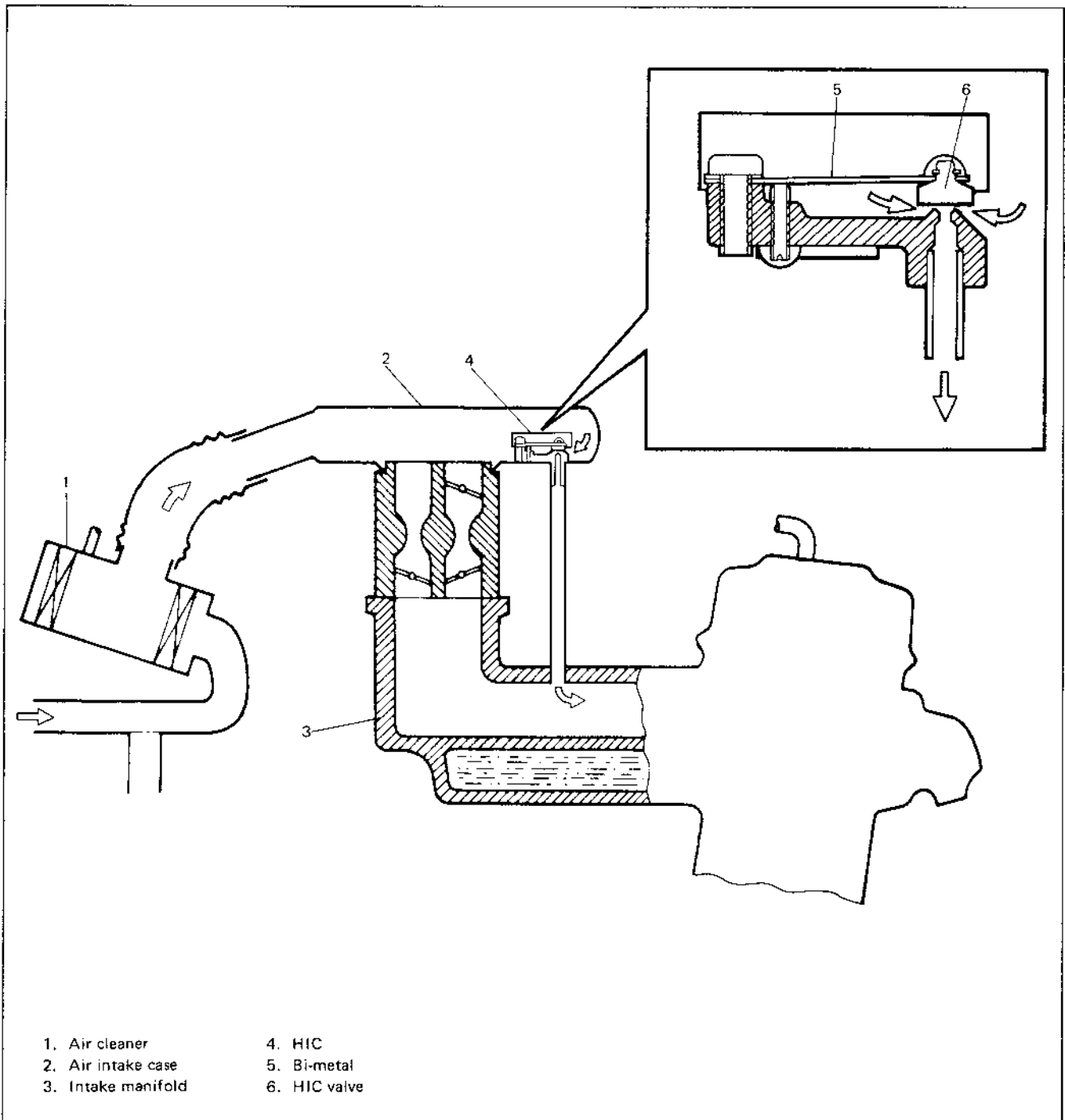


Fig. 5-1-6 Hot idle compensator

## DECELERATION MIXTURE CONTROL SYSTEM

This system consists of a MCV (Mixture Control Valve), jet and vacuum hoses.

This system is designed to introduce fresh air into the intake manifold to reduce generation of excessive HC and CO emission caused by temporary rich air-fuel ratio while rapid deceleration.

The MCV has a pressure balancing orifice and check valve on its diaphragm, and closes when manifold vacuum is constant. As manifold vacuum increases according to rapid deceleration, manifold vacuum applies to MCV chamber "B" through jet, the MCV opens and introduces fresh air into the intake manifold. When manifold vacuum becomes constant, pressure difference between two sectioned chambers "A" and "B" gradually diminishes through pressure balancing orifice, then the MCV closes.

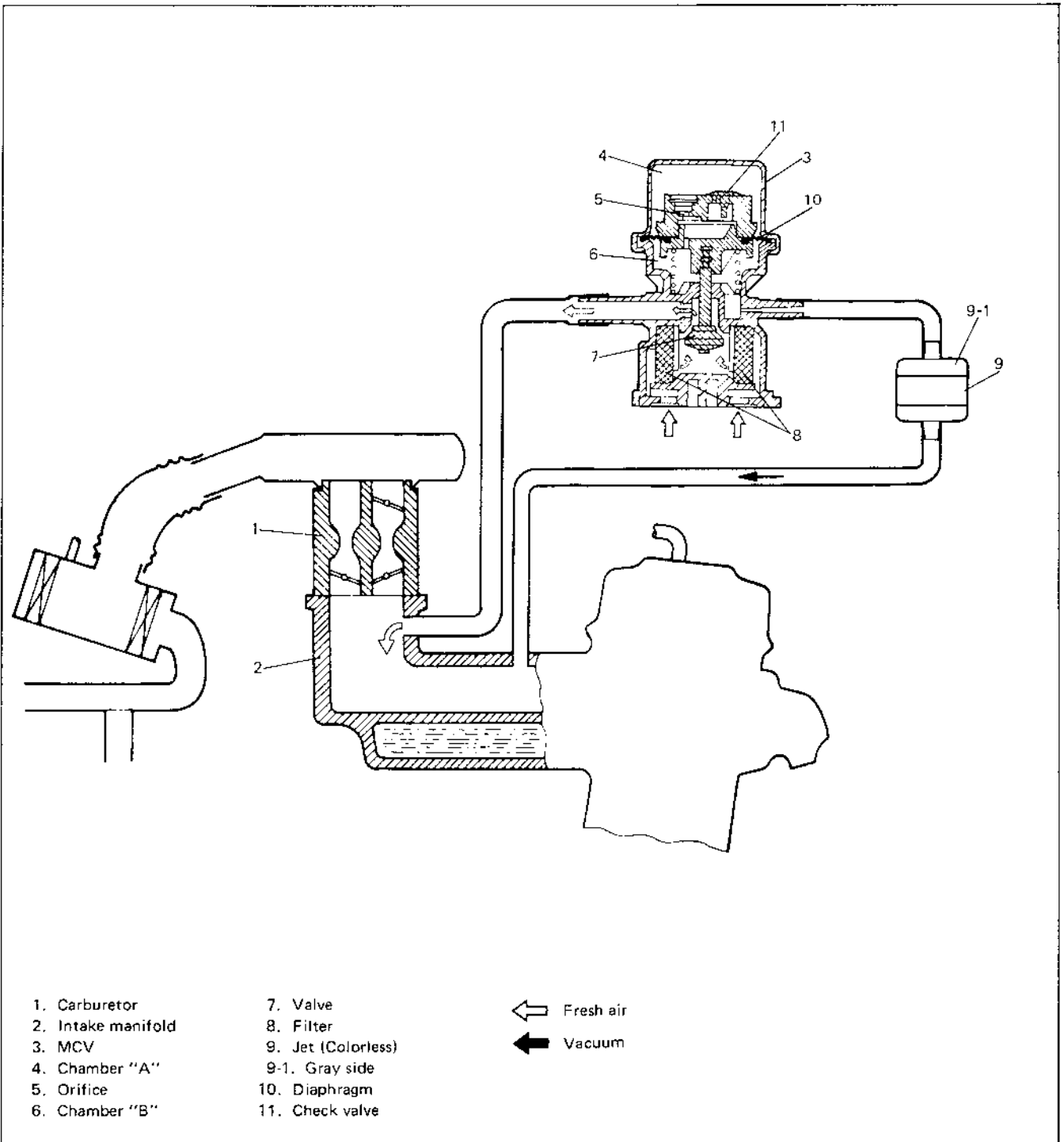


Fig. 5-1-7 Deceleration mixture control system

## COMPUTER CONTROLLED EMISSION CONTROL SYSTEM

### [Feed back system]

A prime purpose of this system is to maintain a controlled air fuel ratio, allowing the catalyst to reduce oxides of nitrogen, hydrocarbons, carbon monoxide and to improve fuel economy simultaneously.

The electronic control module (ECM) and the oxygen sensor are provided in this system.

The oxygen sensor mounted on the exhaust manifold monitors the exhaust gas air fuel ratio and signals to the ECM.

The ECM processes the oxygen sensor signal and controls carburetor air fuel ratio by the operation of the mixture control solenoid in the carburetor.

Thus the signal of the exhaust gas air fuel ratio sensed by the oxygen sensor is fed back to ECM and the carburetor air fuel ratio is controlled.

### [Electronic control module (ECM)]

The ECM controls the fuel cut system, idle-up system, bowl vent system, EGR system and secondary throttle valve system, as well as the feed back system. The ECM is located under the glove box of the instrument main panel. Refer to Fig. 5-1-9.

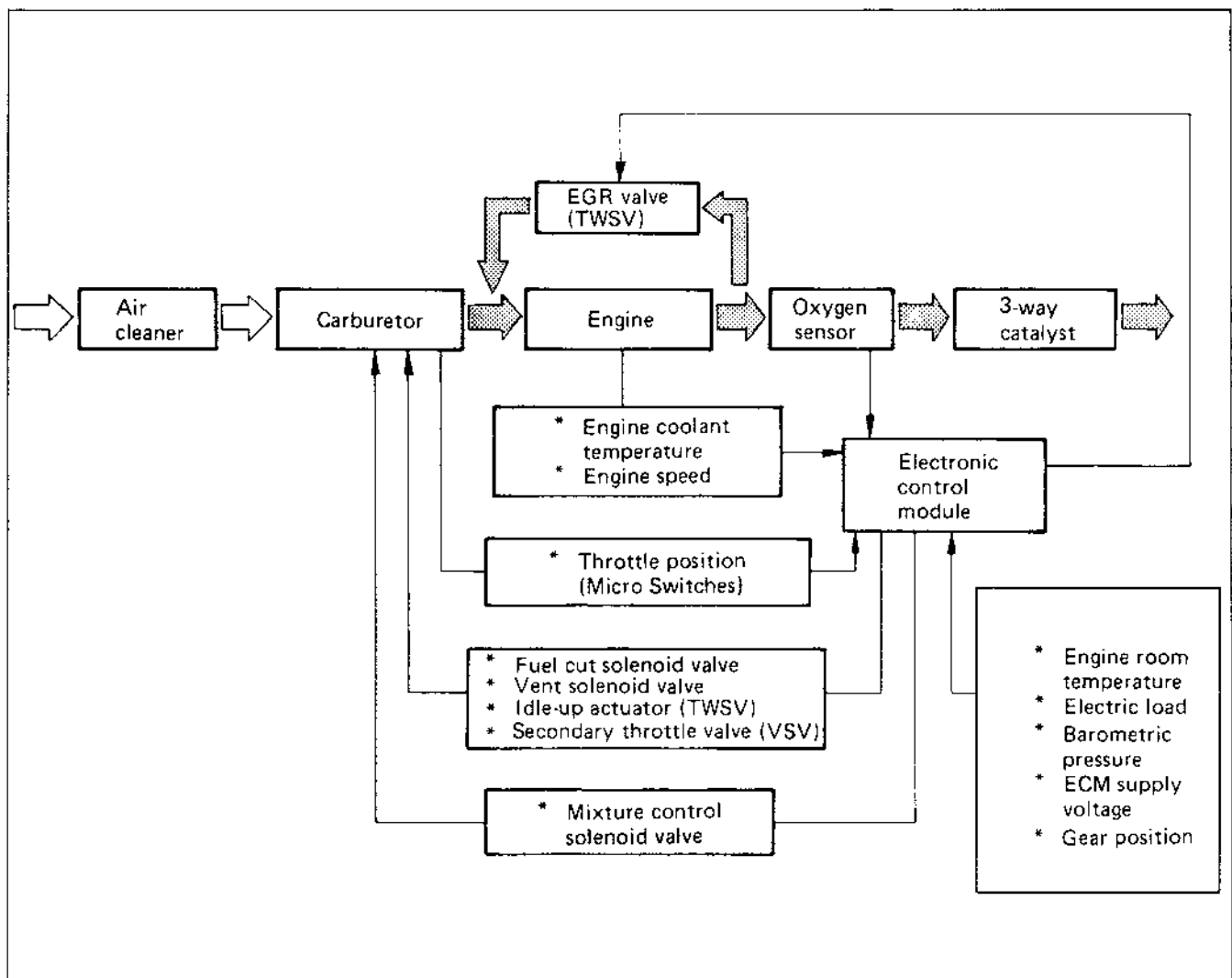


Fig. 5-1-8 Computer controlled emission control system

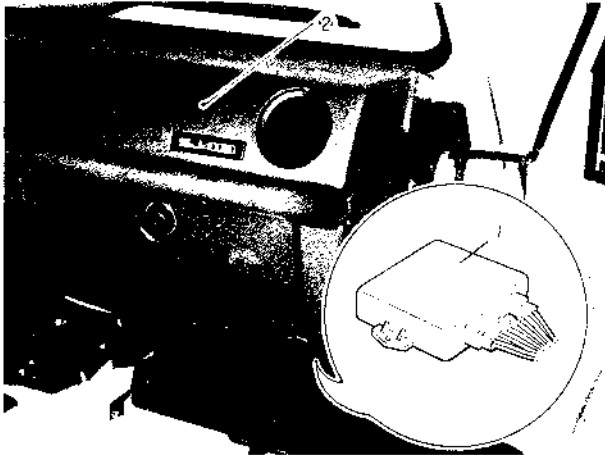


Fig. 5-1-9 ECM

1. ECM
2. Instrument panel

The ECM sensed parameters are as follows:

- **Exhaust Oxygen Concentration.**  
It is sensed by the oxygen sensor installed on the exhaust manifold.

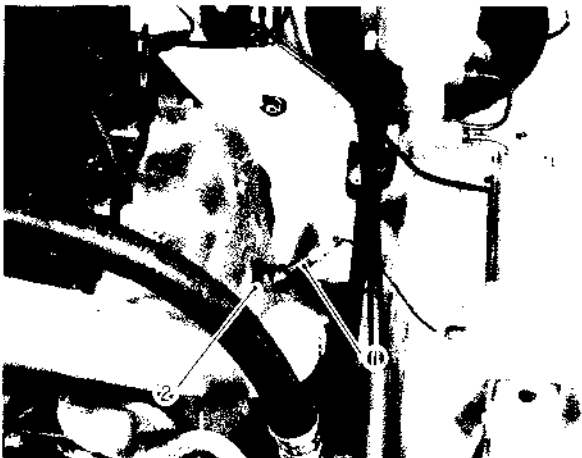


Fig. 5-1-10 Oxygen sensor

1. Oxygen sensor
2. Exhaust manifold

- **Engine coolant temperature.**

It is sensed by the thermal switch installed on the intake manifold.

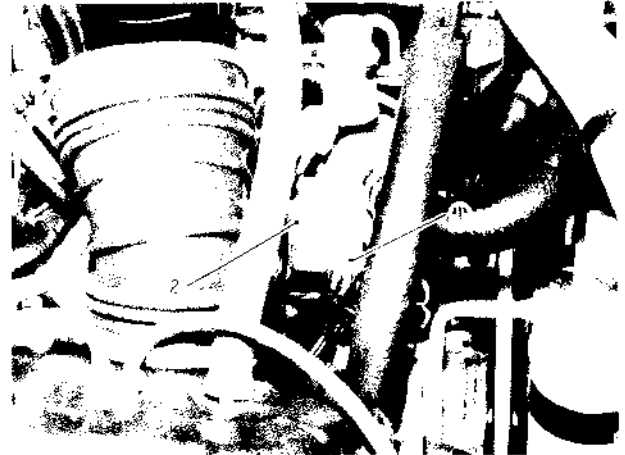


Fig. 5-1-11 Thermal switch

1. Thermal switch
2. Intake manifold

- **Throttle position.**

It is sensed by the micro switches (wide open switch and idle switch) installed on the carburetor.

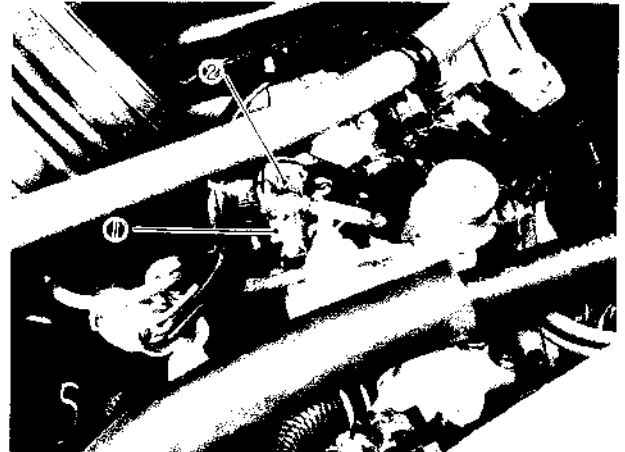


Fig. 5-1-12 Micro switches

1. Idle micro switch
2. Wide open micro switch

- **Engine speed.**

It is computed by the ECM based on the electrical signal received from the ignition system.

- **Electric load.**

The ECM senses electric loads of the following items to provide idle speed compensation.

- a. Small, tail, side marker, license light.
- b. Rear defogger (if equipped).
- c. Heater fan.

- **Gear position.**

It is sensed by the fifth switch located on the transmission. The switch turns "ON" when the gear shift lever is shifted to fifth gear position and "OFF" when shifted to positions other than fifth gear position.

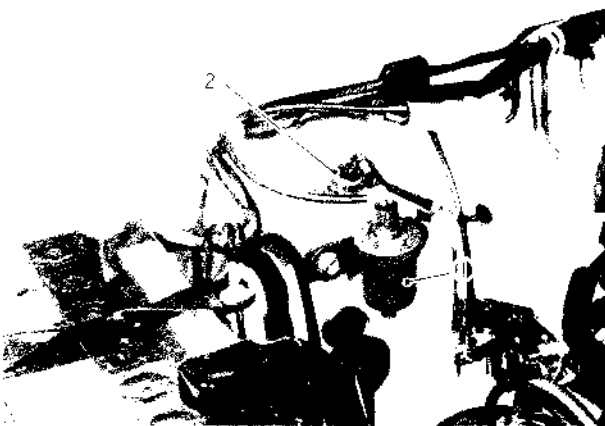


1. Fifth switch
2. Transmission

Fig. 5-1-13 Fifth switch

- **Altitude compensation.**

When the vehicle is at high altitude and the feed back system does not function, the air/fuel mixture becomes richer because of low air density. To compensate the richer air/fuel mixture at high altitude, the high altitude compensator is "ON" by sensing the barometric pressure and sends a signal to the ECM. Following the signal, the ECM controls the mixture control solenoid in the carburetor, thus compensating the air/fuel mixture.



1. High altitude compensator
2. Thermal engine room switch

Fig. 5-1-14 High altitude compensator and thermal engine room switch

- **Engine room temperature compensation.**

Sensing the air temperature in the engine room the thermal engine room switch sends an electric signal to ECM to compensate the air/fuel ratio of the mixture. When the air temperature in the engine room is low, the switch operates to make the mixture rich. When the air temperature in the engine room is high, the switch stops operating, which means, the air/fuel ratio of the mixture is not controlled by the switch. Refer to Fig. 5-1-14 for the thermal engine room switch.

[**Three-way catalyst**]

The three-way catalyst is provided in the exhaust system (exhaust center pipe). The function of the catalyst is to reduce the emission of CO, HC and NOx in the exhaust gas by oxidizing or converting them into CO<sub>2</sub>, H<sub>2</sub>O and N<sub>2</sub> respectively.

**BOWL VENTILATION SYSTEM**

This system has a switch vent solenoid which is operated by the ignition switch and the ECM. It prevents the fuel vapor in the float chamber from flowing out into the atmosphere both when the engine is at a stop and at work. When the ignition switch is at "OFF" position or when cranking the engine (engine not started), the vent passage is closed by the solenoid valve, and therefore, the vapor flows from the float chamber into the vapor storage canister. When the engine is operating, the solenoid receives an electrical signal from the ECM and its valve keeps the inner vent passage open. As a result, the vapor passes through the passage into the carburetor and is drawn into the engine.

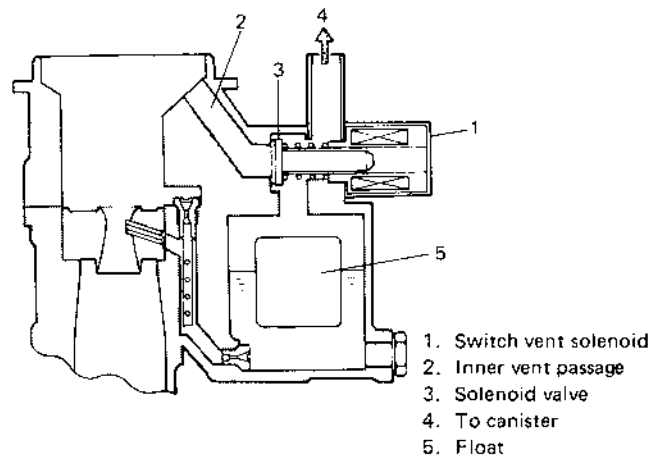


Fig. 5-1-15 Bowl ventilation system



## FUEL CUT SYSTEM

As shown in the figure, the fuel cut solenoid valve is provided in the primary slow system of the carburetor to open and close the fuel passage of the slow system.

As turning the ignition switch "OFF" cuts off the electric current to the solenoid, the solenoid closes the fuel passage. Thus this system contributes to preventing dieseling of the engine after the ignition switch is turned "OFF". Also, during the deceleration and provided that all below listed three conditions exist, the fuel cut solenoid valve operates to cut the fuel feed to the engine temporarily by closing the fuel passage when it received a signal from the ECM.

Such operation of this system prevents the three-way catalyst from getting heated high and improves fuel economy.

Three conditions:

- The coolant temperature is normal.
- The idle micro switch is in "ON" position. In other words, the primary throttle valve is closed.
- The engine revolution is more than 2,400 rpm.

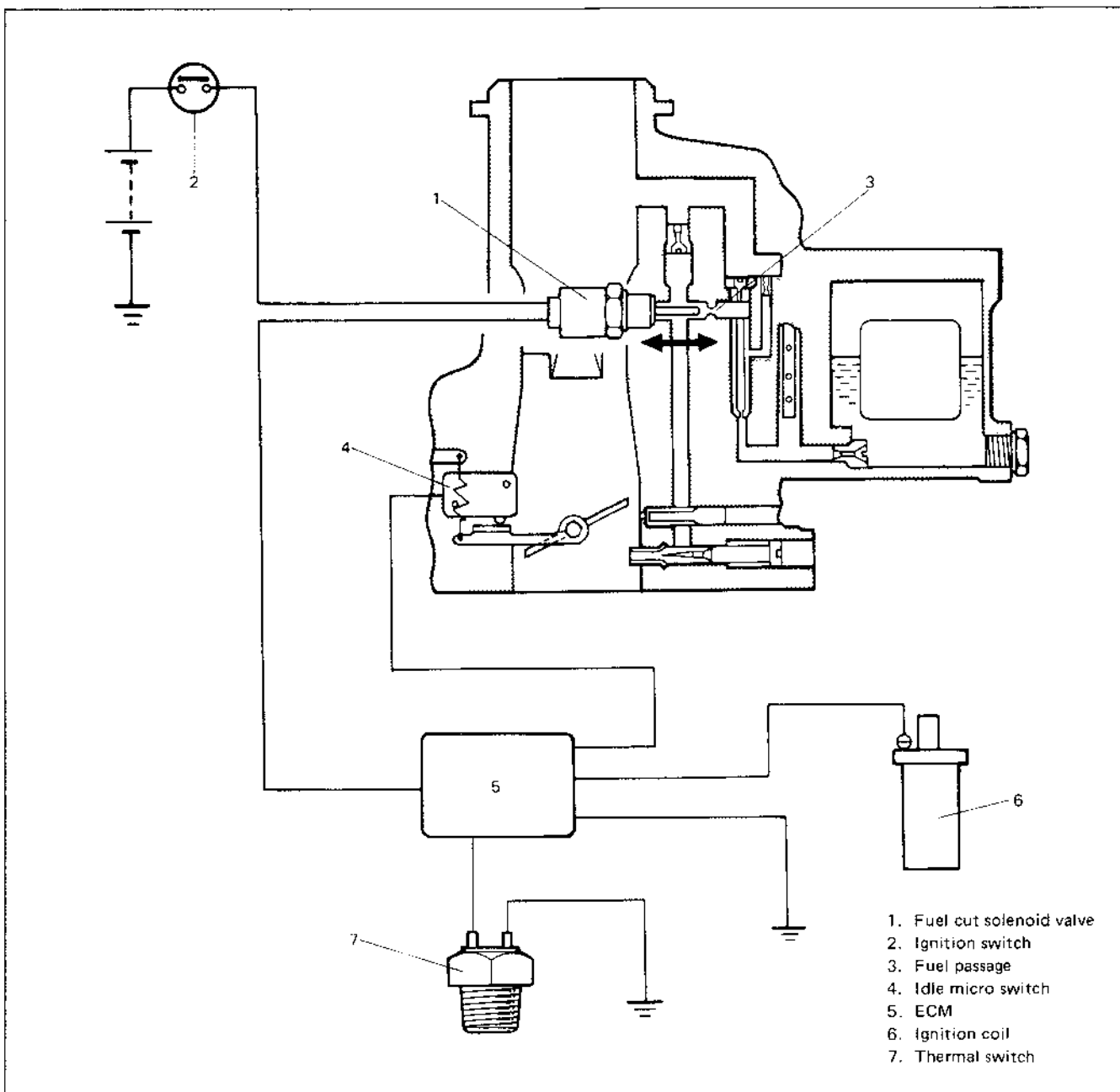


Fig. 5-1-16 Fuel cut system

## EXHAUST GAS RECIRCULATION (EGR) SYSTEM

This system controls the formation of NOx emission by recirculating the exhaust gas into the combustion chamber through the intake manifold.

The diaphragm mounted in the EGR modulator is operated by back pressure of the exhaust gas to open and close the valve. By this opening and closing action of the valve, the EGR modulator controls the vacuum transmitted to the EGR valve.

Under a low load condition such as low speed driving, the exhaust pressure is low. In this state, the diaphragm in the EGR modulator is pushed down by the spring force and the modulator valve opens to allow the air into the vacuum passage from the outside.

As a result, the vacuum transmitted to the EGR valve becomes smaller and so does the opening of the EGR valve. Thus, less amount of exhaust gas is recirculated to the intake manifold.

Under a high load condition such as high speed driving, on the other hand, the exhaust pressure is high. By the high exhaust pressure, the diaphragm in the modulator is pushed up and closes its valve. As the air does not enter the vacuum passage in this state, the vacuum transmitted to the EGR valve grows larger and so does the opening of the EGR valve. Thus, larger amount of exhaust gas is recirculated to the intake manifold.

Under any one of the following conditions, the vacuum passage is closed by the TWSV or BVSV and the vacuum is not transmitted to the EGR valve which, therefore, doesn't operate.

- When the coolant temperature is low. (BVSV is closed)
- When the gear shift lever is shifted to fifth gear position and fifth switch is turned on. (TWSV is closed)
- When HAC is turned on. (TWSV is closed)

Other than the above, EGR valve opens and closes in accordance with the EGR modulator operation.

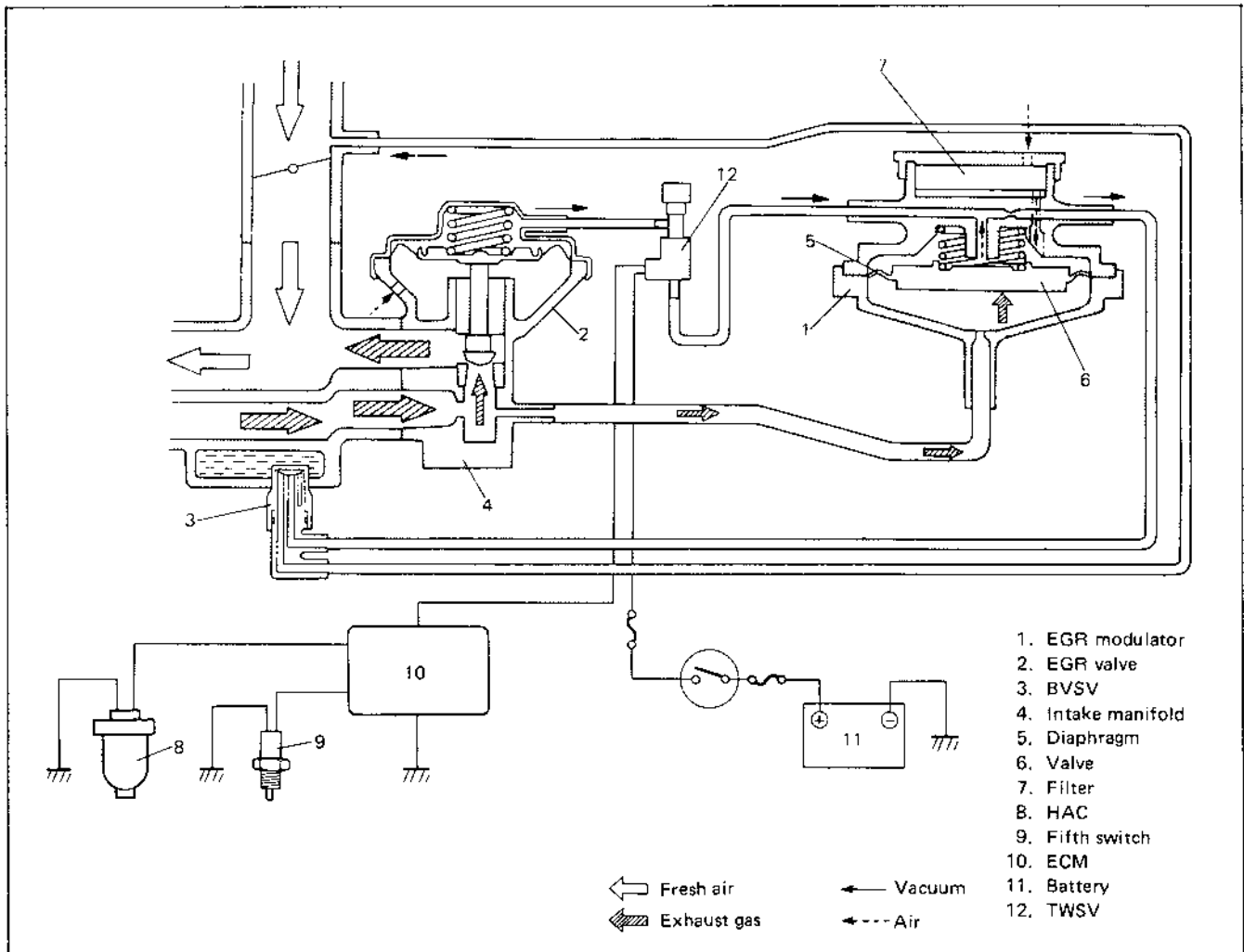


Fig. 5-1-17 EGR system operation

## 5-2. DIAGNOSIS

### POSSIBLE CAUSES OF EMISSIONS TEST FAILURES

Excessive Emission	Explanation	Possible Causes
Hydrocarbons (HC)	Excessive hydrocarbons are caused by an air/fuel mixture that is not burning completely.	<ul style="list-style-type: none"> <li>● Engine not at normal operating temperature</li> <li>● Disconnected, obstructed, leaking, or misrouted vacuum hoses</li> <li>● Vacuum leaks</li> <li>● Maladjusted idle mixture</li> <li>● Improper adjusted/sticking choke</li> <li>● Maladjusted initial spark timing</li> <li>● Defective spark plugs, wires or distributor cap</li> <li>● Malfunctioning MCV</li> <li>● Lead contamination of catalytic converter</li> <li>● Malfunctioning feed back system</li> </ul>
Carbon monoxide (CO)	Excessive carbon monoxide emissions are due to a mixture that is rich.	<ul style="list-style-type: none"> <li>● Engine not at normal operating temperature</li> <li>● Maladjusted idle mixture</li> <li>● Improperly adjusted/sticking choke</li> <li>● Lead contamination of catalytic converter</li> <li>● Leaking carburetor fuel passages or gaskets</li> <li>● Carburetor float level</li> <li>● Restricted air cleaner element</li> <li>● Malfunctioning feed back system</li> </ul>
Oxides of nitrogen (Nox)	Excessive oxides of nitrogen are generally due to high temperatures in the combustion chamber.	<ul style="list-style-type: none"> <li>● Obstructed/leaking/misrouted vacuum lines</li> <li>● Improper operation of the EGR system</li> <li>● Plugged EGR passages</li> <li>● Inoperative BVSV or TWSV</li> <li>● Lead contamination of catalytic converter</li> <li>● Malfunctioning feed back system</li> </ul>

## EGR DIAGNOSIS

Condition	Possible Cause	Correction
Engine idles abnormally rough and/or stalls.	<p>EGR valve vacuum hoses mis-routed.</p> <p>Leaking EGR valve.</p> <p>EGR valve gasket failed or loose EGR attaching bolts.</p> <p>Improper vacuum to EGR valve at idle.</p> <p>Sticky EGR valve</p>	<p>Check EGR valve vacuum hose routing. Correct as required.</p> <p>Check EGR valve for correct operation.</p> <p>Check EGR attaching bolts for tightness. If no loose, remove EGR valve and inspect gasket.</p> <p>Check vacuum from carburetor EGR port with engine at stabilized operating temperature and at idle speed.</p> <p>Check EGR valve for correct operation.</p>
Engine runs rough on light throttle acceleration and has poor part load performance.	<p>EGR valve vacuum hose mis-routed.</p> <p>Loose EGR attaching bolts</p> <p>Sticky or binding EGR valve.</p> <p>EGR modulator valve blocked or air flow restricted.</p> <p>Wrong or no EGR gasket.</p>	<p>Check EGR valve vacuum hose routing. Correct as required.</p> <p>Torque bolts.</p> <p>Same as listing in "Engine Idles Abnormally Rough and/or Stalls" condition. Clean EGR passage deposits. Perform EGR System Check.</p> <p>Check EGR modulator valve operation.</p> <p>Install new gasket, torque attaching parts.</p>
Engine stalls on decelerations.	<p>EGR modulator valve blocked of air flow restricted.</p> <p>Restriction in EGR vacuum line.</p> <p>VSV filter plugged.</p> <p>Sticking or binding EGR valve.</p>	<p>Check EGR modulator valve operation.</p> <p>Check EGR vacuum lines for kinks, bends, etc. Remove or replace hoses as required.</p> <p>Check VSV for correct operation.</p> <p>Check EGR valve for excessive deposits causing sticky or binding operation.</p>
<p>Part throttle engine detonation.</p> <p><b>NOTICE:</b> Non-functioning EGR valve could contribute to part throttle detonation. Detonation can be caused by several other engine variables. Perform ignition and carburetor related diagnosis.</p>	<p>EGR modulator valve blocked of air flow restricted.</p> <p>Insufficient exhaust gas recirculation flow during part throttle accelerations.</p>	<p>Check internal control valve operation.</p> <p>Check EGR valve hose routing. Check EGR valve operation. Repair or replace as required. Replace valve as required. Check EGR passages and valve for excessive deposit. Clean as required. Check VSV operation.</p>

Condition	Possible Cause	Correction
Engine starts but immediately stalls when cold.  <b>NOTICE:</b> Stalls after start can also be caused by carburetor problems.	EGR valve hoses misrouted.  BVSV is out of order.	Check EGR valve hose routings.  Check BVSV. Replace as necessary.

### PCV SYSTEM DIAGNOSIS

Condition	Possible Cause	Correction
Unstable idle, frequent stalling.	PCV valve completely stuck. Hose plugged.	Replace valve. Check hoses.
Oil in air cleaner.	PCV system plugged.	Replace valve.

## 5-3. MAINTENANCE SERVICE

### GENERAL

If the emission control hoses were disconnected and any system component was removed for service, be sure to reinstall the component properly and route and connect hoses correctly after service. Refer to Fig. 5-1-1 for hose connection.

### PCV SYSTEM

#### Checking PCV System

#### NOTICE:

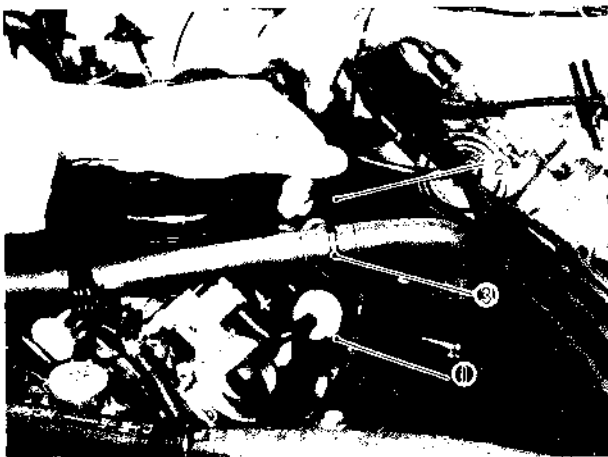
If the engine is idling rough, this may be caused by a stuck PCV valve, plugged hoses or vacuum leakage of PCV line, therefore, never adjust the carburetor idle without first checking the PCV valve and hoses.

#### [PCV hoses]

Check hoses for connection, leakage, clog, and deterioration. Replace as necessary.

#### [PCV valve]

- 1) Disconnect PCV hoses at three way joint.
- 2) Run engine at idle.
- 3) Place your thumb over the end of disconnected PCV hose to check for vacuum. If there is no vacuum, check for clogged hose or valve. Replace as necessary.



1. PCV valve
2. PCV hose
3. Three way joint

Fig. 5-3-1 Checking vacuum

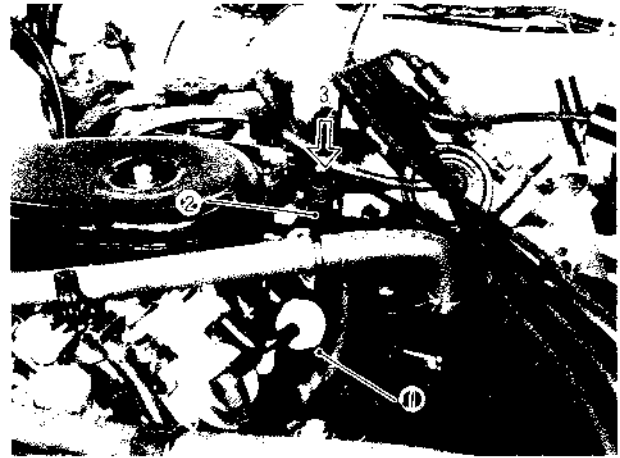
- 4) After checking vacuum, stop engine and check PCV valve for sticking.

With engine stopped, remove PCV hose and connect a new hose to PCV valve.

Blow air into new hose and check that air flows with difficulty from cylinder head side to intake manifold side. If air flows without difficulty, the valve is stuck in "Open" position. Replace PCV valve. Before installing new PCV valve to intake manifold, wind sealing tape on thread of the valve.

#### IMPORTANT:

Do not suck air through PCV valve. The petroleum substances inside the valve and fuel vapor inside intake manifold are harmful.



1. PCV valve
2. New PCV hose
3. Blow air

Fig. 5-3-2 Checking PCV valve for sticking

- 5) Connect PCV hose securely.

## TCAC SYSTEM

### Checking TCAC System

- 1) Check vacuum hose for connection, deterioration or damage. Replace as necessary.

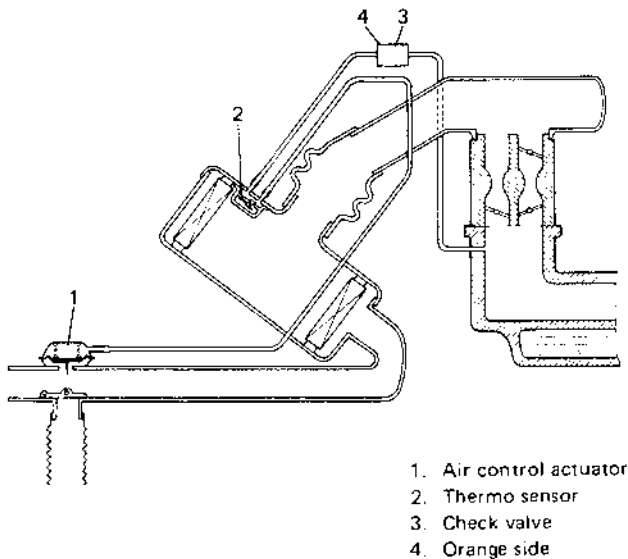


Fig. 5-3-3 TCAC system

- 2) With engine at a stop, make sure that the valve indicated in figure is completely closed (closing warm air side). This check should be carried out by putting finger into duct after removing warm air hose from it.

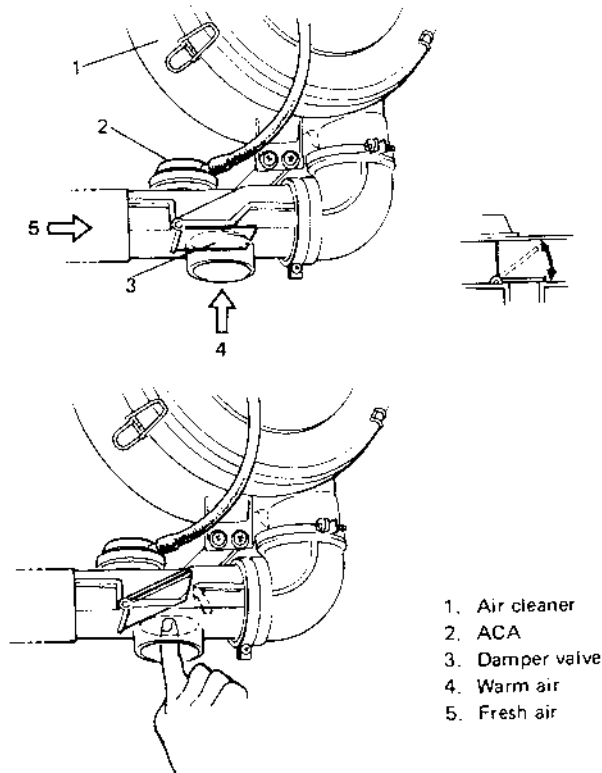


Fig. 5-3-4 Checking TCAC system

- 3) Check that when engine is started (and run at idle speed) under the condition that air cleaner is cool, valve on warm air side becomes fully open and one on fresh air inhaling side is completely closed.

- 4) If nothing was found faulty in the above step, connect warm air hose.

If found defective in above step 2) or 3), inspect following parts according to each procedure.

### [Air control actuator]

- 1) Disconnect vacuum hose from thermo sensor.
- 2) Make sure that damper opens fully when more than 20 cmHg (7.87 in.Hg) vacuum is applied to ACA.

Also, make sure that damper is held at the same position when a constant vacuum is applied to it.

If damper doesn't open or close smoothly, or it isn't held at the same position, replace ACA.

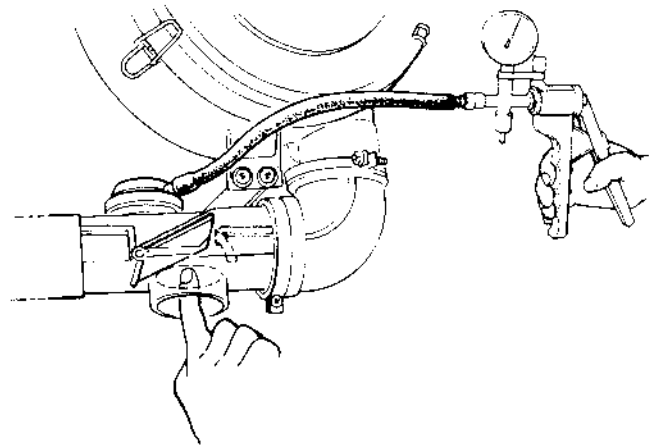


Fig. 5-3-5 Checking ACA

### [Thermo sensor]

- 1) Remove air cleaner case cap.
- 2) Disconnect two vacuum hoses from thermo sensor.
- 3) Measure the temperature around thermo sensor.
- 4) Close a nozzle with finger and then blow air into nozzle. If measured temperature is above 40°C (104°F), air should come out of thermo sensor valve (valve is open) as shown in Fig. 5-3-6.

If the temperature is below 25°C (77°F), air should not come out (valve is closed).

Replace defective parts.

**NOTICE:**

- To check thermo sensor for operation at higher than 40°C (104°F) temperature when thermo sensor is lower than 25°C (77°F), remove thermo sensor from air cleaner cap and warm it up with hair drier or photo light before checking.
- Never touch bimetal or valve in thermo sensor.

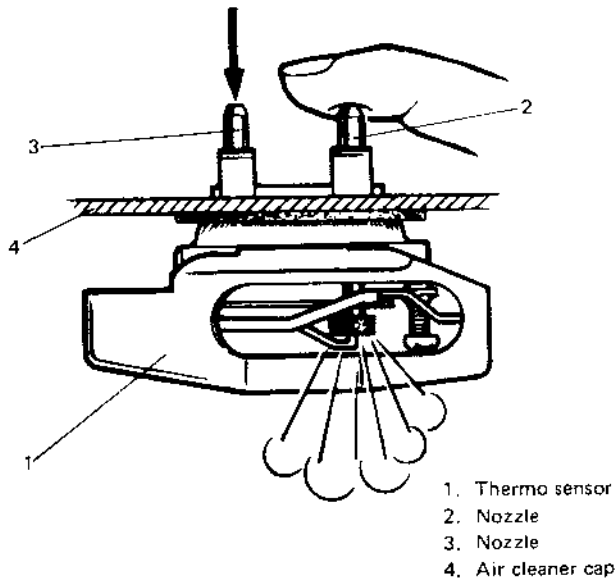


Fig. 5-3-6 Checking thermo sensor

- 5) After checking, reinstall air cleaner case cap, and connect 2 vacuum hoses to thermo sensor.

[Check valve]

- 1) Remove check valve with vacuum hose.
- 2) Using vacuum pump gauge, check for the following.

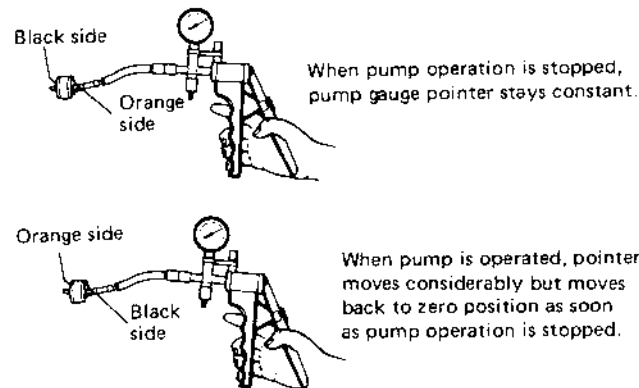


Fig. 5-3-7 Checking check valve

If found defective, replace.

- 3) Install check valve with its orange side directed toward thermo valve.

**EVAPORATIVE EMISSION CONTROL SYSTEM**

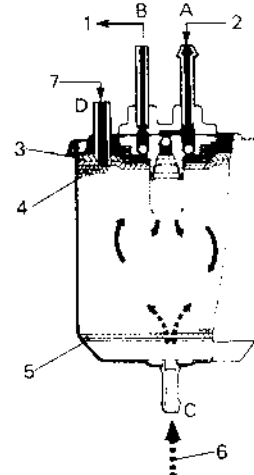
Checking vapor storage canister

**IMPORTANT:**

**DO NOT SUCK** the nozzles on canister. Fuel vapor inside the canister is harmful.

- 1) Disconnect negative cable at battery.
- 2) Disconnect 3 hoses from canister.
- 3) Remove canister.
- 4) With pipes C and D closed with fingers, blow air into pipe A strongly, and air should come out from pipe B.
- 5) When air is blown into pipe B, air should not pass through pipe A, C or D.
- 6) When air is blown into pipe C, air should come out from pipe A, B and D.

If operation differs from above description, canister must be replaced.



1. Vapor to intake manifold
2. Vapor from fuel tank
3. Filter
4. Charcoal
5. Filter
6. Air flow under vacuum condition
7. Vapor from float chamber when ignition switch is "OFF"

Fig. 5-3-8 Checking canister

- 7) Install canister and connect hoses and battery negative cable.



[Hoses]

Visually inspect hoses and pipe for cracks, damage, or excessive bends, and hose connection for tightness.

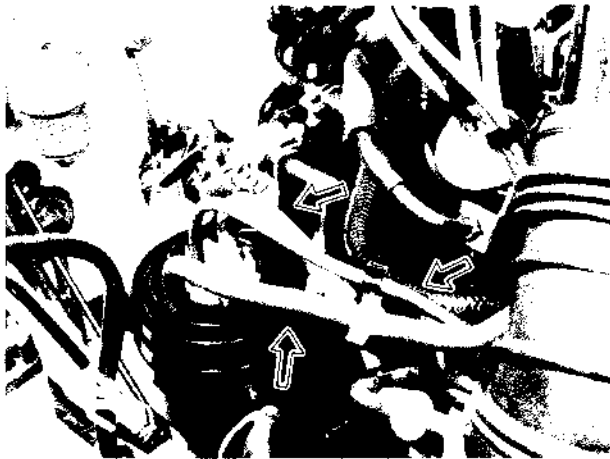


Fig. 5-3-9

### HOT IDLE COMPENSATOR (HIC)

#### Checking Hot Idle Compensator

- 1) Remove air intake case with hose.
- 2) Check temperature around HIC with thermometer.
- 3) If temperature is below 45°C (113°F), air should not come out of HIC when air is blown into hose. If temperature is above 65°C (149°F), air comes out of HIC. Replace HIC if defective.
- 4) After checking, install air intake case and connect hose to intake manifold.

#### NOTICE:

- To check HIC for operation at higher than 65°C (149°F) temperature when HIC (bi-metal) temperature is lower than 45°C (113°F), warm it up with hair drier or photo light before checking.
- Never touch bimetal or valve in HIC.

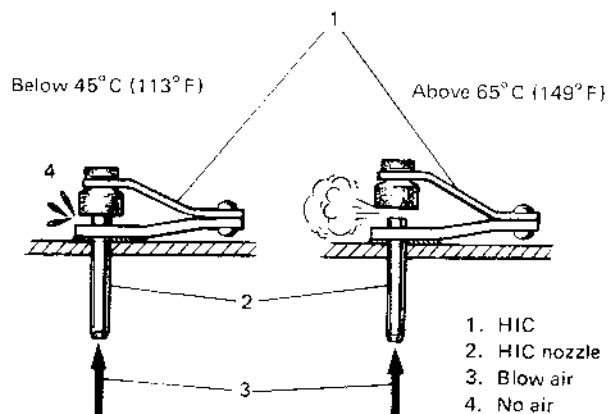


Fig. 5-3-10

### DECELERATION MIXTURE CONTROL SYSTEM

#### Checking

[Hoses]

Inspect each hose for pinholes, cracks or damage. Also check to ensure that each joint is securely connected. Any part found defective must be corrected or replaced.



Fig. 5-3-11

[Mixture control valve (MCV)]

- 1) Warm up the engine to normal operating temperature.
- 2) Disconnect hose (1) and reconnect it. At this time, check that air is drawn into MCV.

#### NOTICE:

At this time, the engine will idle rough or die, but this is normal.

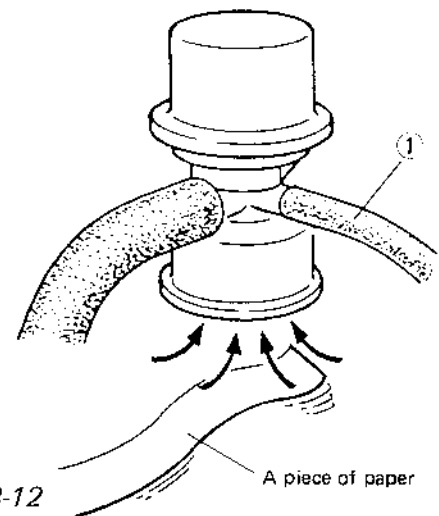


Fig. 5-3-12

If the above checks show anything wrong, replace it.

[Jet]

- 1) Remove jet.
- 2) When blowing air into pipe ①, air should come out of pipe 2.  
Replace clogged jet.
- 3) Install jet with its gray side directed toward MCV.

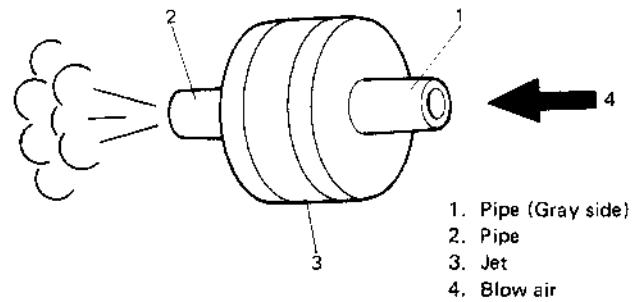


Fig. 5-3-13

### FEED BACK SYSTEM

Whether feed back system including oxygen sensor and ECM (Electronic Control Module) is in good condition or not, can be judged by checking for operation of "SENSOR" light in instrument cluster.

As previously outlined, "SENSOR" light automatically flashes at 60,000 miles, 120,000 miles and so on indicated on odometer when running warmed up engine. And this automatic flashing at above mileages proves that system is in good condition.

Should any of following malconditions occur, the system check can be performed according to "System check flow chart", even when mileage indicated by odometer is not any of 60,000 miles and 120,000 miles.

- Fuel consumption increases excessively even in normal driving.
- Engine tends to stall.
- Engine is hard to start.

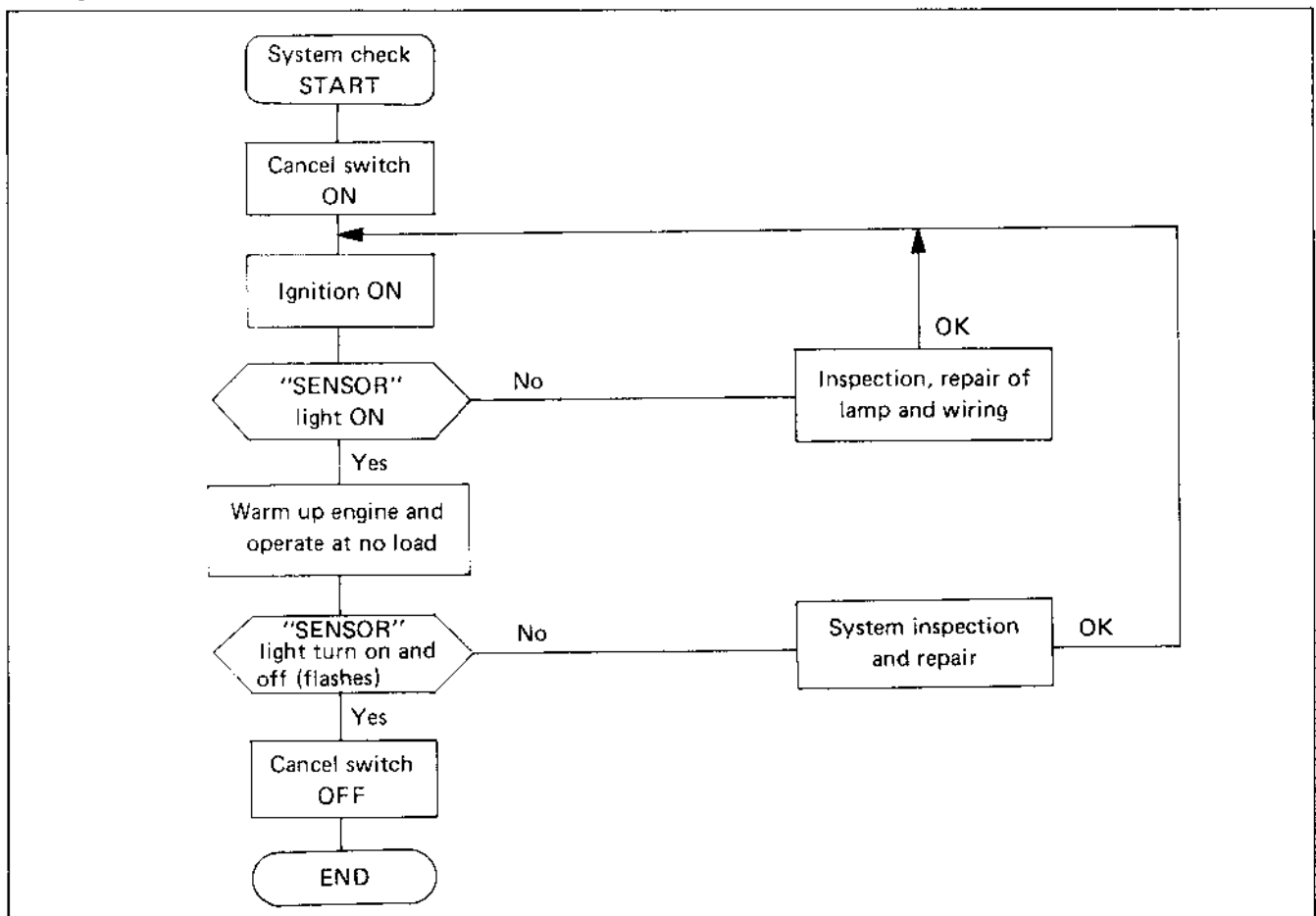


Fig. 5-3-14 System check flow chart

### Checking feed back system

- 1) Operate (turn ON) cancel switch located at the place shown in below figure.

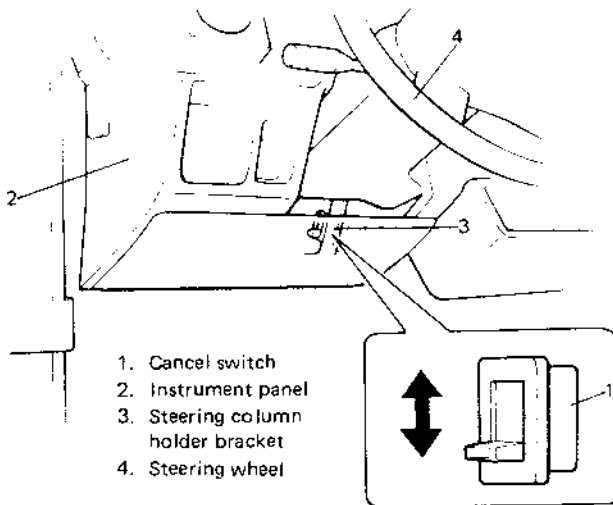


Fig. 5-3-15 Cancel switch

- 2) Turn ignition switch ON without running engine.

At this time, "SENSOR" light should light (should not flash).

If it does not light, check electric circuit of the light, namely light for blow off and lead wire for disconnection.

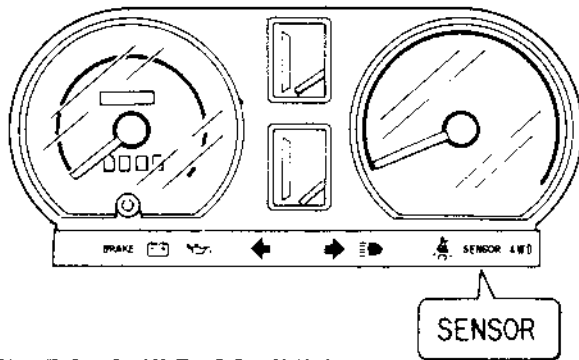


Fig. 5-3-16 "SENSOR" light

- 3) After lighting of the light is confirmed, start engine and warm it up to normal operating temperature.
- 4) When engine is warmed up, run engine at 1,500 – 2,000 rpm. In this state, make sure that "SENSOR" light flashes. Flashing of light proves that system is in good condition. If light does not flash, it can be caused by one of the following. Check them and replace or adjust as necessary.

- Defective oxygen sensor
  - Defective mixture control solenoid valve
  - Defective carburetor or maladjusted idle mixture
  - Defective thermal switch
  - Disconnected or loosely connected electric lead wires of emission control systems
  - Defective ECM
  - Defective micro switches (idle and wot)
- 5) After making sure that "SENSOR" light flashes, turn cancel switch OFF. Light should go off.
  - 6) Stop engine.

### Checking idle and wide open micro switches

Check idle and wide open micro switches according to the following procedures.

1. Warm up engine to normal operating temperature and stop engine.
2. For this check, use check terminal coming from the lower right of instrument panel as shown.

Connect negative prod of ohmmeter to check terminal and positive prod to body.

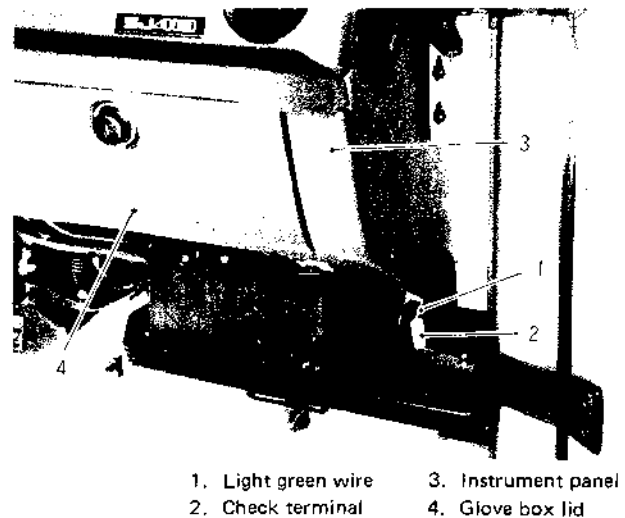


Fig. 5-3-17

3. Turn ignition switch to "ON" position.
4. Observe ohmmeter indicator reaction to make sure for the following movement for each throttle valve position.

THROTTLE VALVE POSITION	INDICATOR MOVEMENT
Idle position	Swing
1/2 open	Stay after deflection
Full open	Swing

**NOTICE:**

If indicator doesn't deflect at all, reverse above connection, that is, negative prod to body and positive one to check terminal, and carry out the same check.

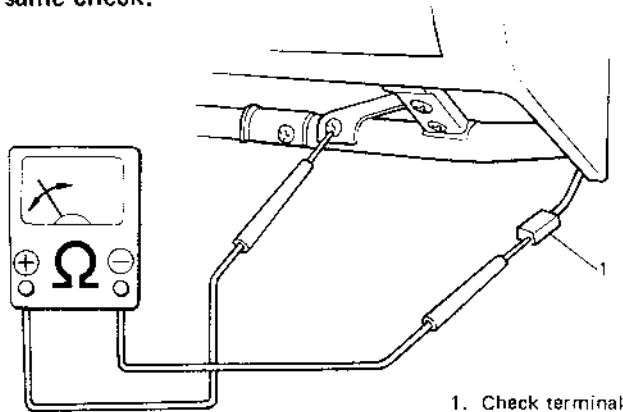
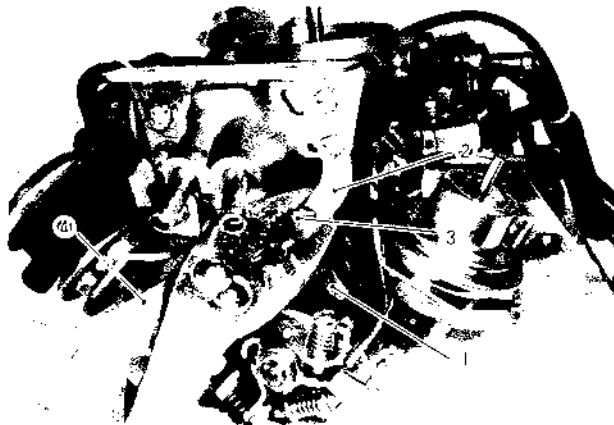


Fig. 5-3-18

If check results are not satisfactory, check idle and wide open micro switches as follows or their circuits for continuity referring to item "checking sensors and their lead wires" (p. 5-32).

[Idle micro switch]

- 1) Remove carburetor following normal service procedures.
- 2) Turn fast idle cam counterclockwise and insert a suitable pin available then into holes in cam and bracket to lock the cam.



1. Fast idle cam
2. Bracket
3. Pin
4. Plier

Fig. 5-3-19

- 3) Connect ohmmeter to terminals of idle micro switch. Check for continuity between terminals. When throttle valve is at idle position, ohmmeter should indicated "zero" ohm.
- 4) Open throttle valve by 1/4 to 1/2, and ohmmeter indicator should indicate infinity. If check results in steps 3) and 4) are not satisfactory, replace idle micro switch with a new one.

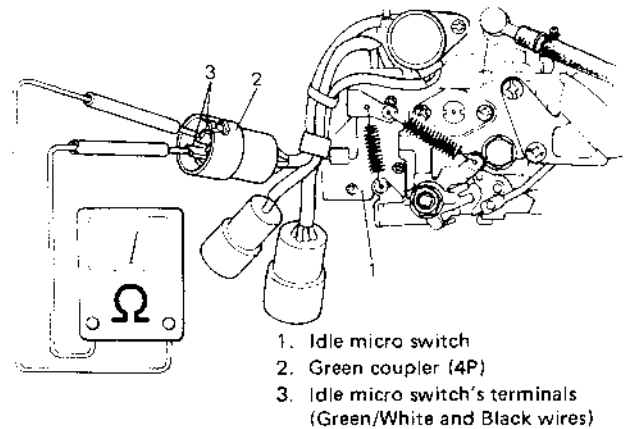


Fig. 5-3-20 Connecting ohmmeter to idle micro switch

- 5) Open throttle valve slowly till throttle valve-to-carburetor bore clearance becomes 0.36 – 0.62 mm (0.014 – 0.024 in) and check that ohmmeter indicator moves from "zero" ohm to infinity then.

If the above indicator movement does not occur within specified range, make adjustment by bending lever shown in below figure. Bend lever down when clearance is below specification and up when over specification.

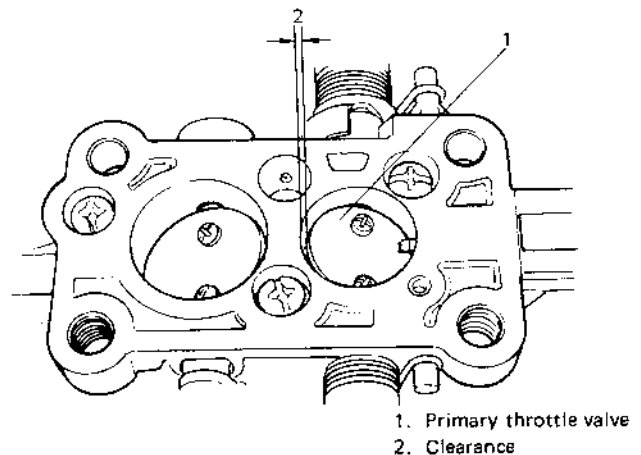
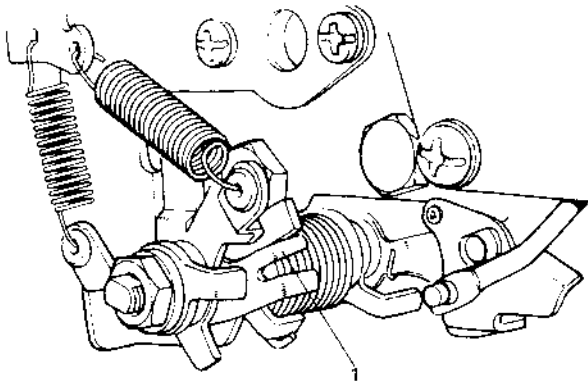


Fig. 5-3-21 Clearance between throttle valve and carburetor bore



1. Lever

Fig. 5-3-22 Lever

[Wide open micro switch]

- 1) Connect ohmmeter to wide open micro switch as indicated in below figure. At this time, ohmmeter indicator should indicate "zero" ohm.
- 2) When throttle valve is fully opened, ohmmeter should indicate infinity. If any defect, replace.

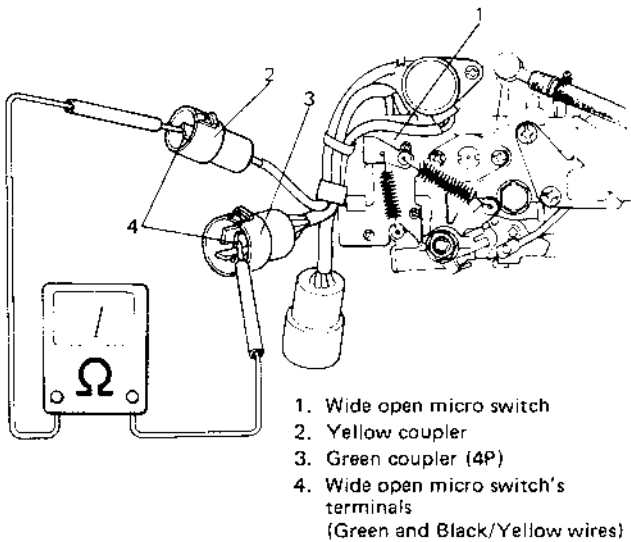
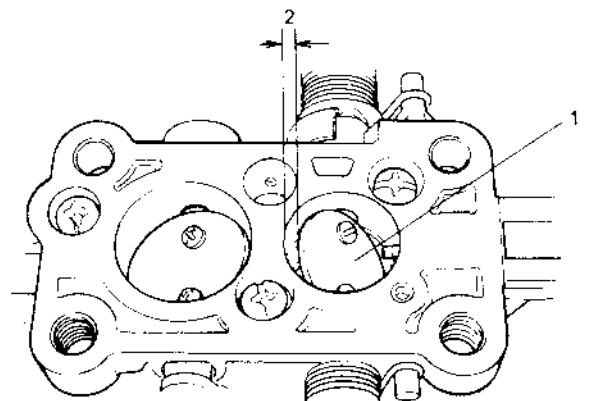


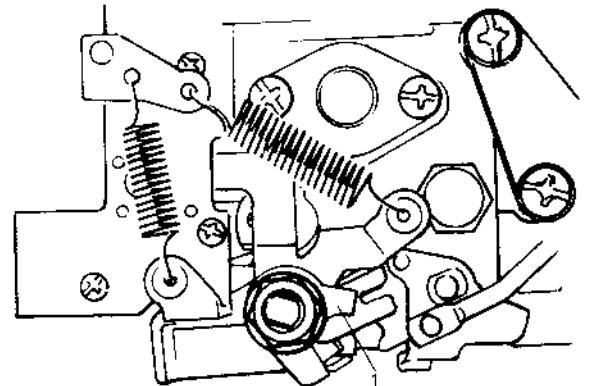
Fig. 5-3-23 Checking wide open micro switch

- 3) Open throttle valve gradually until the ohmmeter indicates infinity. Then, using a vernier, measure the clearance between throttle valve and carburetor bore as shown in below figure. The clearance should be within 6.0 – 7.2 mm (0.24 – 0.28 in). If the clearance is out of specified range, make adjustment by bending the lever in below figure.



1. Primary throttle valve  
2. Clearance

Fig. 5-3-24 Clearance between throttle valve and carburetor bore



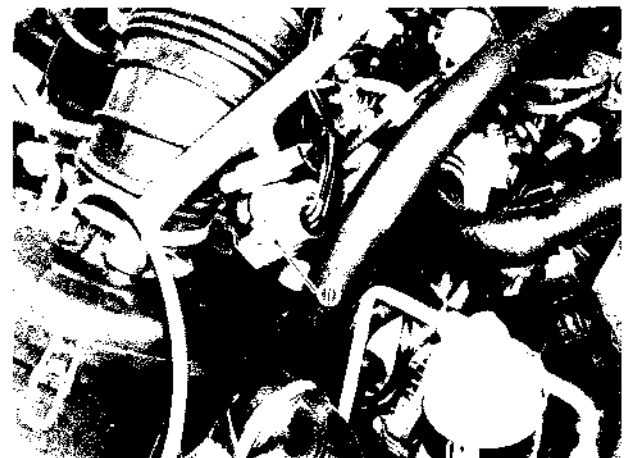
1. Wide open micro switch lever

Fig. 5-3-25 Wide open micro switch lever

Upon completion of checks, install carburetor following normal service procedures.

#### Checking mixture control solenoid valve

- 1) Check to make sure that ignition switch is at "OFF" position.
- 2) Disconnect couplers from ECM, TWSVs and VSV. *at 147th*
- 3) Disconnect mixture control solenoid valve lead wires at the coupler (5P). *Wire up to ECM (2) pin*



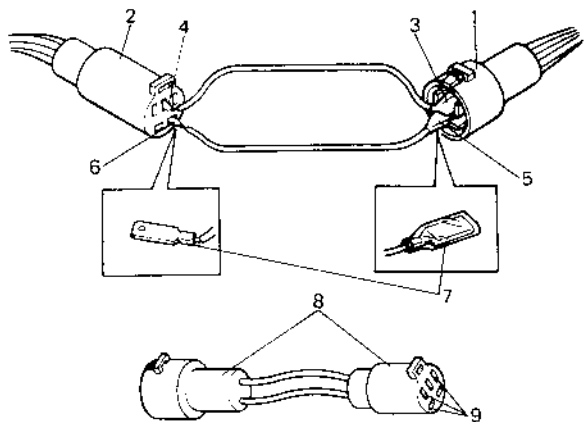
1. Green coupler (5P)

Fig. 5-3-26

- 4) Using couplers of the same shape as that mentioned in step 3) or 1P couplers, connect only mixture control solenoid valve wire terminals (Yellow/Black terminal of coupler ① and Black/White terminal of coupler ②, White terminal of coupler ① and Blue/Red terminal of coupler ②).

**NOTICE:**

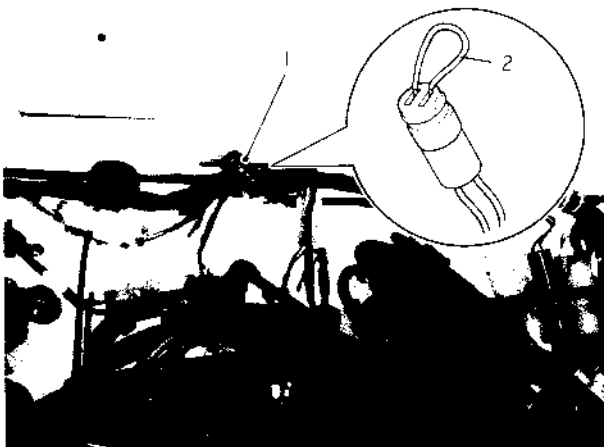
- Couplers must be used to connect each terminal.
- Use special care when connecting terminals as wrong connection may cause damage to other parts.



- |                                 |  |
|---------------------------------|--|
| 1. Coupler of MCSV side         | 7. 1p coupler  |
| 2. Coupler of wire harness side | 8. 5p coupler (when using this coupler, leave positions indicated as 9 in figure blank). |
| 3. Yellow/Black wire terminal   | 9. Blank   |
| 4. Black/White wire terminal    |  |
| 5. White wire terminal          |  |
| 6. Blue/Red wire terminal       |  |

Fig. 5-3-27

- 5) Remove cap of duty check coupler located on dash panel and connect terminals with a lead wire to short them.



- |                       |
|-----------------------|
| 1. Duty check coupler |
| 2. Lead wire          |

Fig. 5-3-28

- 6) Turn ignition switch "ON" and "OFF" repeatedly (without starting engine) and check if MCSV operating sound is heard as ignition switch is operated.

Operating sounds prove its proper operation.

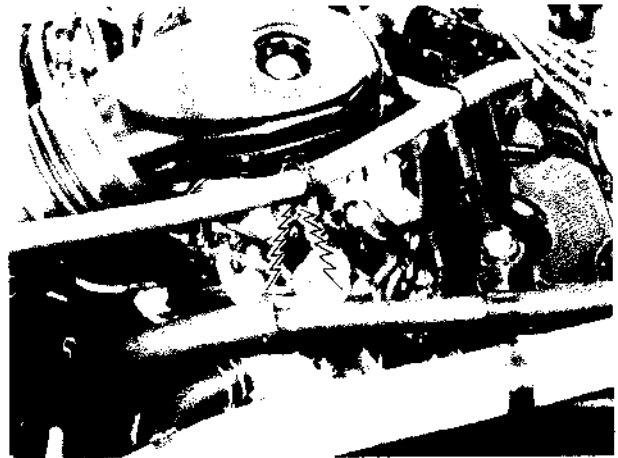


Fig. 5-3-29

- 7) Upon completion of checks, re-connect disconnected couplers to original positions securely.

**Checking thermal switch**

**NOTICE:**

For the rough check of the operation, thermal switch can be checked by warming up (above 46.5°C, 116°F) or cooling down (below 30°C, 86°F) the engine without being removed from the intake manifold.

The check procedure is the same as the following except item 1), 2), 5) and 6).

- 1) Drain cooling system.
- 2) Remove thermal switch from intake manifold.
- 3) Cool switch to below 30°C (86°F), and using an ohmmeter, check that there is continuity between terminals.

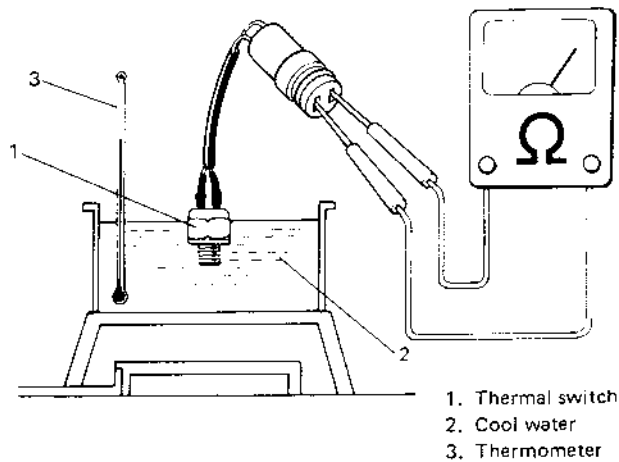


Fig. 5-3-30 Checking thermal switch in cool water

- 4) Heat switch to above 46.5°C (116°F), and check that there is no continuity between terminals.

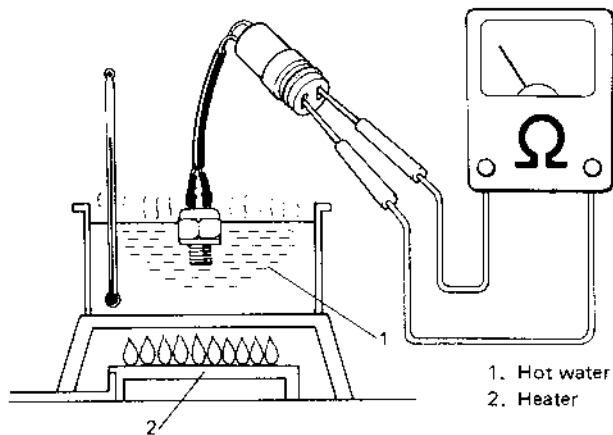
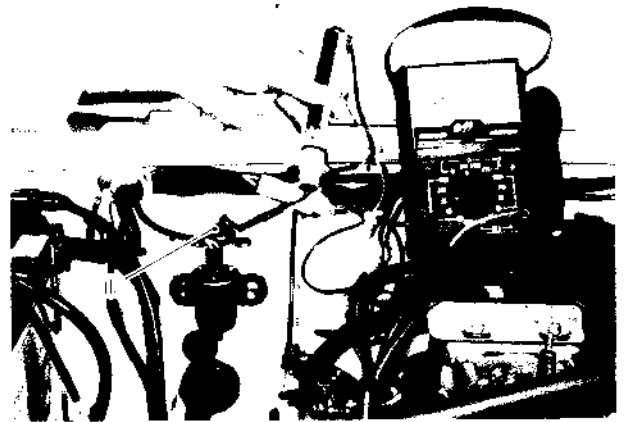


Fig. 5-3-31 Checking switch in hot water

- 5) Reinstall switch to intake manifold. Before installing, wind sealing tape on its thread.  
6) Refill cooling system.

#### Checking thermal engine room switch

- 1) Disconnect connector of switch and connect ohmmeter between terminals on switch side.
- 2) Make sure that switch is "ON" (ohmmeter indicates "Zero" ohm) when atmospheric temperature is below 7°C (44°F) and "OFF" (ohmmeter indicates infinity) when above 19.5°C (67°F).



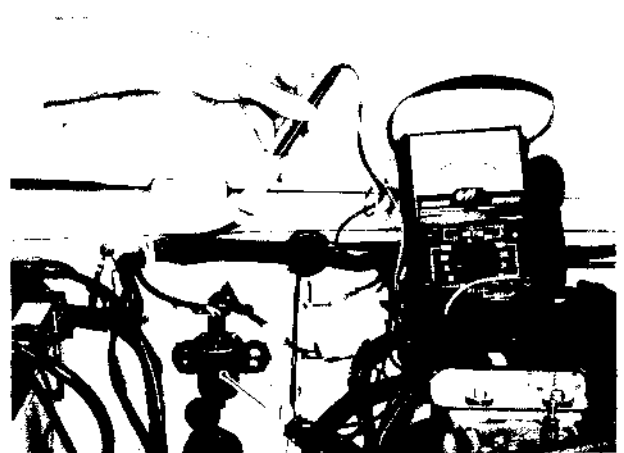
1. Thermal engine room switch

Fig. 5-3-32 Checking thermal engine room switch

#### Checking high altitude compensator

Check the compensator as follows:

- 1) Disconnect the coupler of compensator and connect an ohmmeter to the compensator.
- 2) Check to be sure that;
  - If the altitude of the place where this check is performed is above 1,220 m (4,000 ft), the ohmmeter should indicate "Zero" ohm (compensator is ON).
  - If the altitude is below 1,220 m (4,000 ft), the ohmmeter should indicate infinity ohm (compensator is OFF).
- 3) After checking, connect the coupler.



1. High altitude compensator

Fig. 5-3-33 Checking high altitude compensator

### Checking oxygen sensor

- 1) Warm up the engine to normal operating temperature.
- 2) Disconnect the connector of the oxygen sensor.

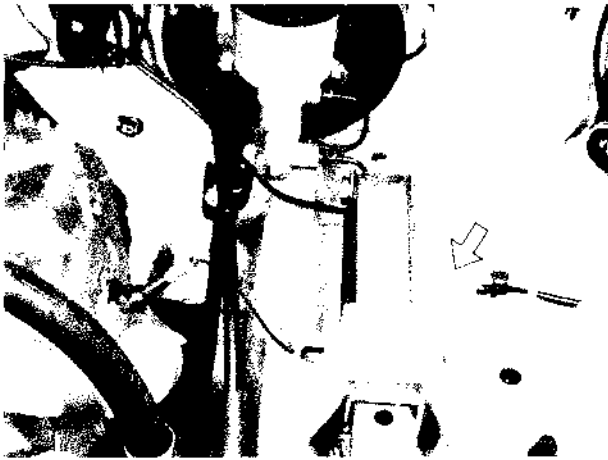


Fig. 5-3-34 Connector of oxygen sensor

- 3) Connect the voltmeter between the oxygen sensor side terminal of the disconnected connector and the ground as shown in below figure.

### NOTICE:

- Be sure to use a voltmeter whose inner resistance is more than some  $M\Omega$  per 1V or a digital type voltmeter. Any other voltmeter should not be used because accurate measurements are not obtained.
- NEVER apply voltage to the oxygen sensor as it may cause damage to the sensor.
- NEVER connect ohmmeter to the oxygen sensor as it may cause damage to the sensor.

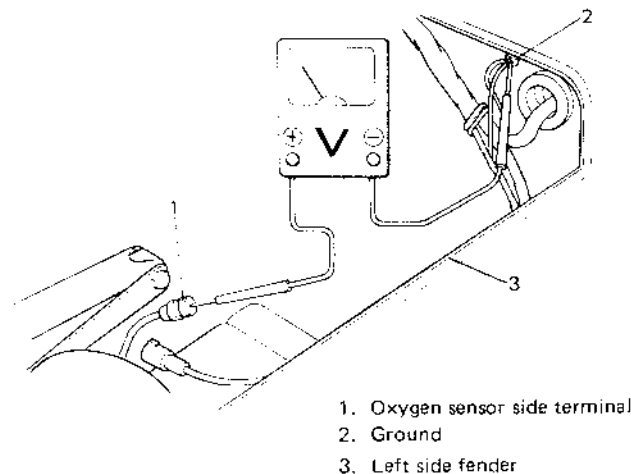
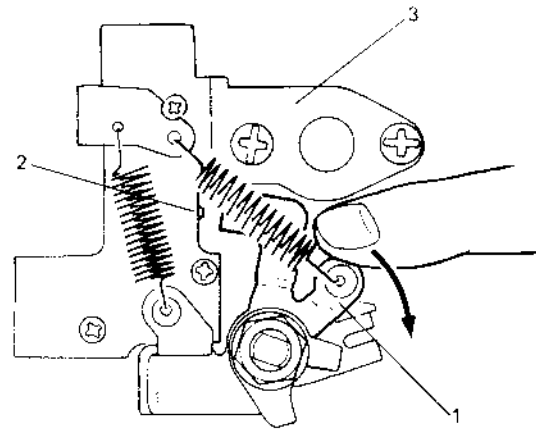


Fig. 5-3-35 Connecting voltmeter

- 4) While keeping the engine running at 1,500 – 2,000 rpm, turn the wide open micro switch "OFF" by moving the lever with the finger as shown in below figure. Then take the reading of the voltmeter to make sure it is about 0.8V.



1. Lever
2. Wide open micro switch
3. Carburetor

Fig. 5-3-36 Moving lever

- 5) With the engine running at 1,000 – 1,500 rpm, disconnect the vacuum hose at the intake manifold as shown in below figure. At this time, check to ensure that the voltmeter indicator is below 0.2V.



1. Vacuum hose
2. Intake manifold
3. MCV

Fig. 5-3-37 Disconnecting vacuum hose

- 6) After checking, reconnect the vacuum hose to the intake manifold and the connector of oxygen sensor.



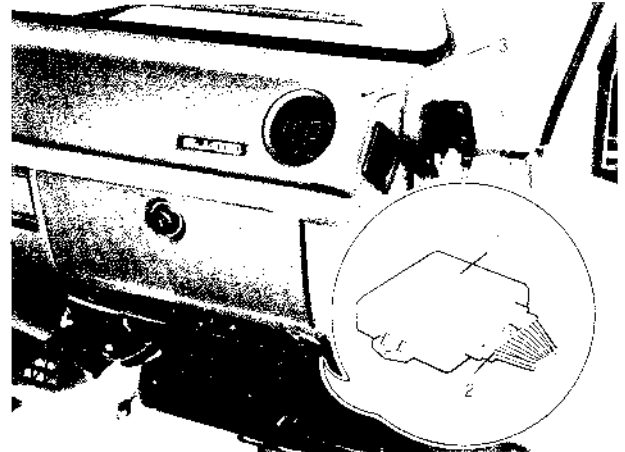
### Checking feed back system circuits

When the feed back system does not seem to operate properly even after each of its components has been checked and proved normal, it is necessary to check each circuit of the feed back system. The checking procedure of each circuit is described here.

#### [Checking ECM ground circuits]

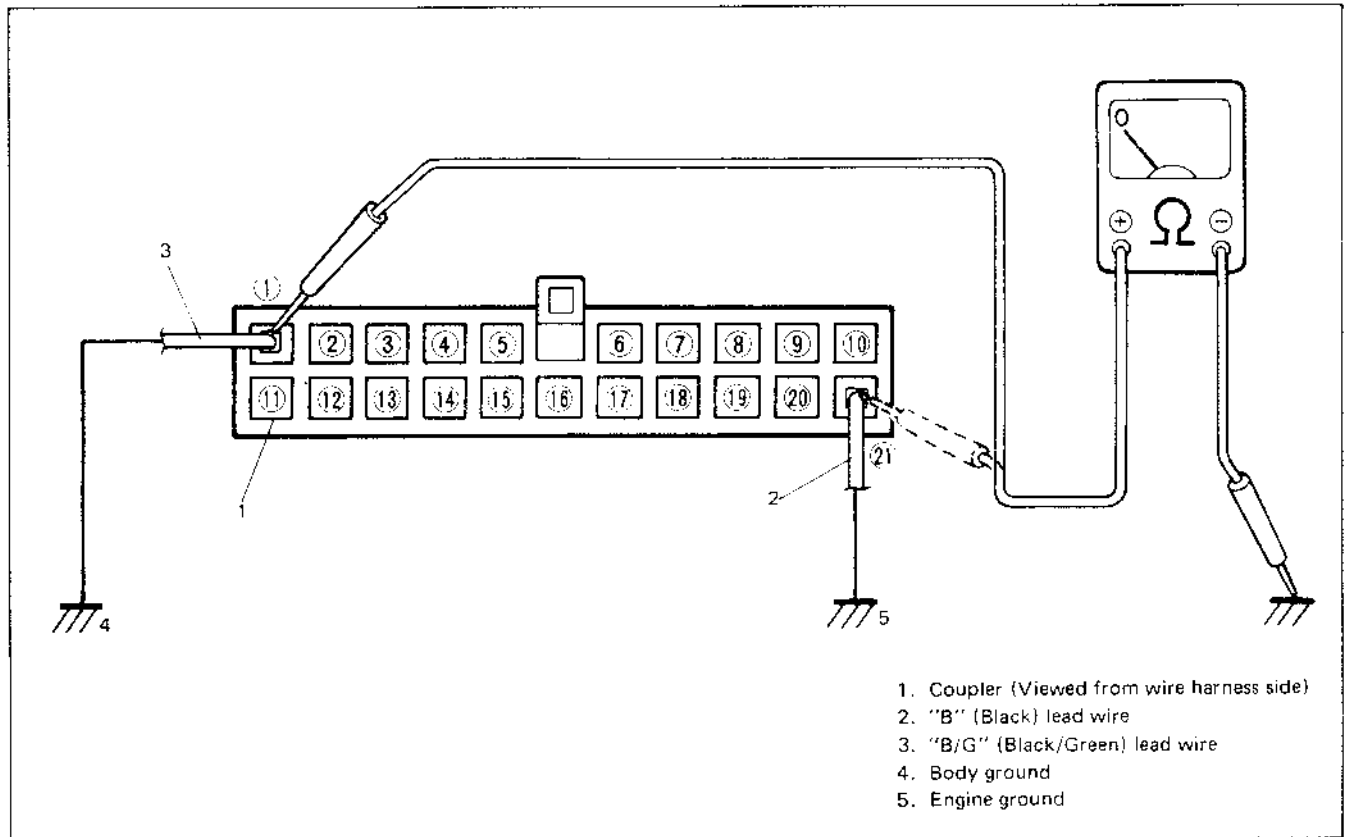
The ECM is grounded both at the dash panel and the intake manifold. If either grounding is not made securely, the feed back system will not operate. Therefore, check if the ECM is properly grounded at these two points according to the following procedure.

- 1) Turn OFF the ignition switch.
- 2) Disconnect the coupler from the ECM.
- 3) Connect an ohmmeter between the terminal ① of the disconnected coupler (on the wiring harness side) and the body (ground) as shown in below figure, and measure the resistance. Then repeat the same with the terminal ②.



1. ECM (Electronic Control Module)
2. Coupler
3. Instrument main panel

Fig. 5-3-38 ECM and coupler

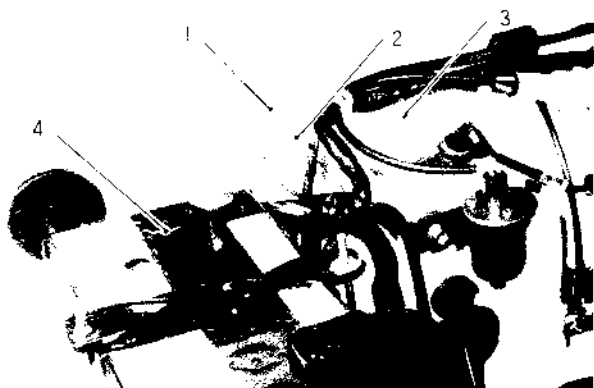


1. Coupler (Viewed from wire harness side)
2. "B" (Black) lead wire
3. "B/G" (Black/Green) lead wire
4. Body ground
5. Engine ground

Fig. 5-3-39 Checking ECM ground circuit

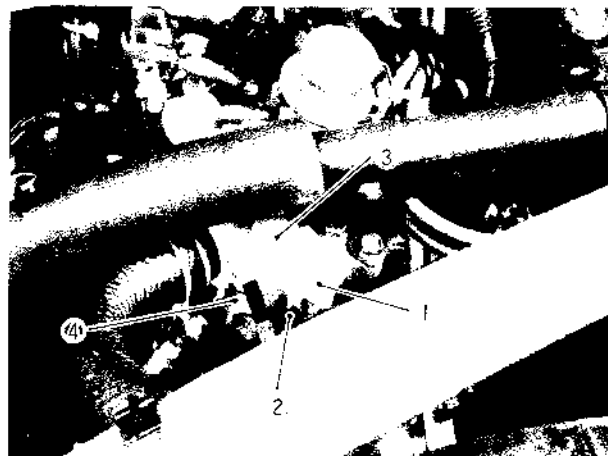
4) If the measured resistance between each terminal ( ① and ② ) and the body is "ZERO (0)" ohm, the ECM is grounded securely at two points. If the resistance is not "ZERO (0)" ohm, the possibility is that the lead wire between the terminal ( ① or ② ) and the ground is not securely grounded or disconnected.

The below figures show the particular points where "B" and "B/G" wires are grounded. Check for their secure grounding by referring to these figures.



1. Body ground                      3. Dash panel  
2. Black/Green lead wire        4. Battery

*Fig. 5-3-40 Body ground*



1. Engine ground                    3. Thermostat cap  
2. Black lead wire                4. Intake manifold

*Fig. 5-3-41 Engine ground*

5) After checking, connect the coupler to ECM securely.

[Checking ECM power circuits]

Connected to the ECM are the ignition coil and solenoids or solenoid valves. If a disconnection or a failure of contact occurs within a circuit (power circuit) including any of these coil or solenoids or solenoid valves, signals will not be sent to the ECM and as a result, the feed back system will not operate properly. Therefore, check the power circuits according to the following procedure.

- 1) Disconnect the coupler connected to the ECM.
- 2) Turn ON the ignition switch but be sure not to run the engine.
- 3) Connect a voltmeter between the terminal ② of the disconnected coupler (on the wiring harness side) and the body (ground) as shown in below figure and measure the voltage. And then repeat the same with each of the terminals ③, ⑧, ⑨, ⑫, ⑬, ⑯ and ⑰. If the measured voltage between each terminal and the body is about 12V, each circuit is in good condition.
- 4) If about 12V is not obtained in the above check, the particular circuit may be disconnected or out of contact. Check the circuit for such conditions.
- 5) After checking, connect the coupler to ECM securely.

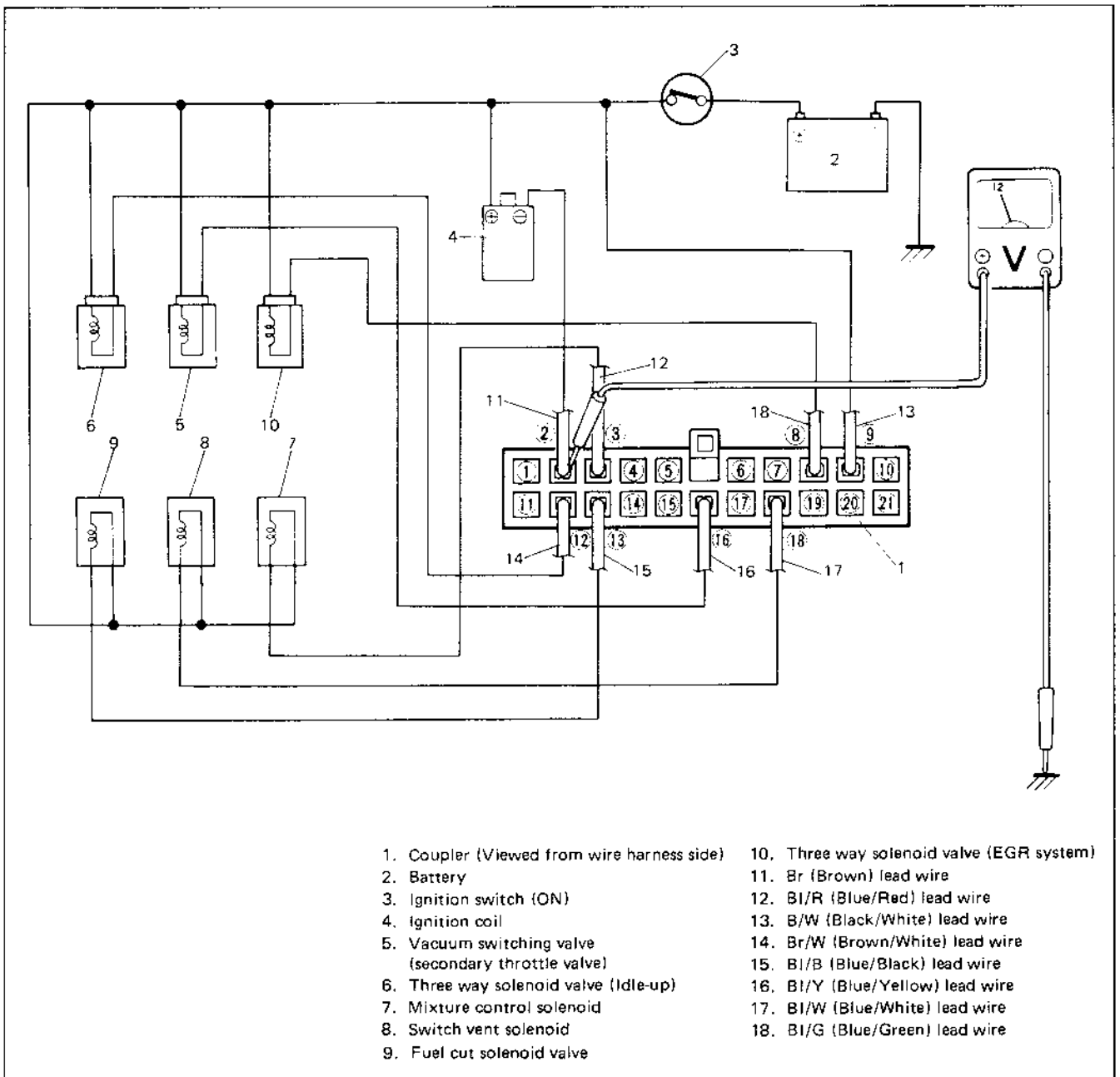


Fig. 5-3-42 Checking ECM power circuits

[Checking sensors and their lead wires]

The sensors constituting the feed back system are; wide open micro switch, idle micro switch, thermal switch, high altitude compensator, thermal engine room switch and fifth switch. If any of the above sensors malfunctions or if the sensor circuit has some trouble, signals are not sent to the ECM and consequently the feed back system will not function properly.

Therefore, check each sensor and its circuit according to the following procedure.

- 1) Turn OFF the ignition switch.
- 2) Disconnect the coupler from the ECM.
- 3) Connect the ohmmeter between the terminal 4 of the disconnected coupler and the terminal ① (ground) as shown in below figure and measure the resistance. And then repeat the same with each of the terminals 5, ⑪, ⑭, ⑮ and ⑲.

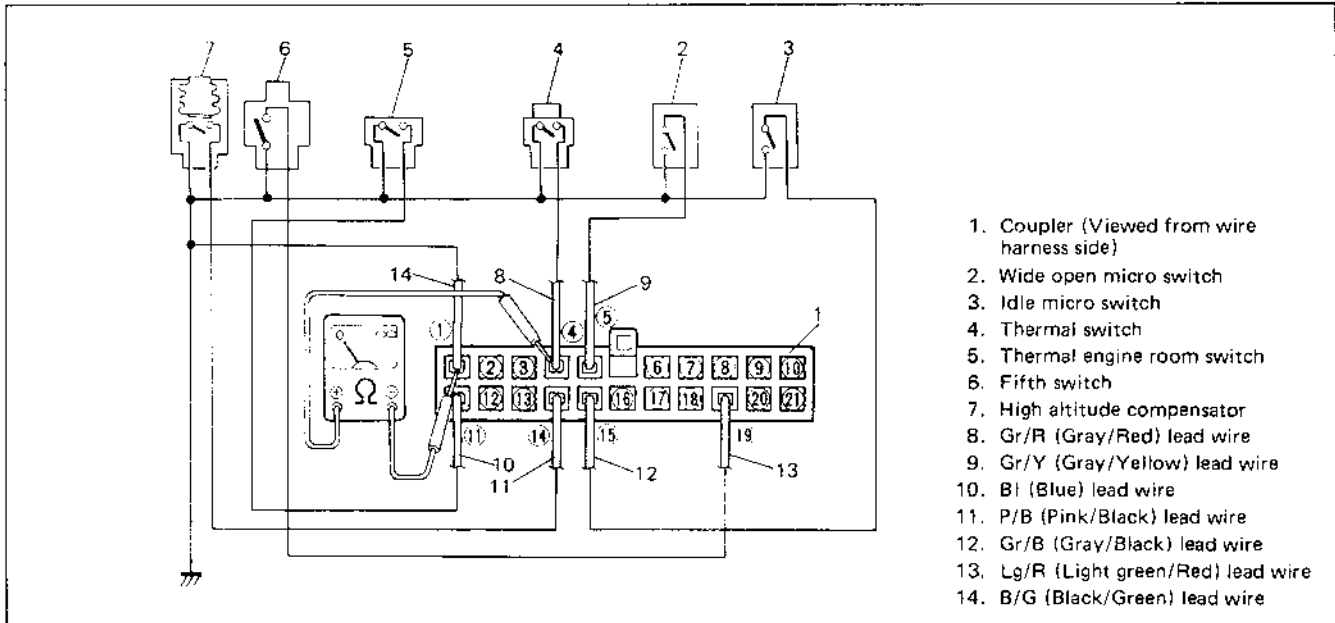


Fig. 5-3-43 Checking sensors and their circuits

- 4) If each ohmmeter reading is as given below, the sensor and its circuit are in good condition. But if not, the sensor itself may be defective or the lead wire disconnected or out of contact. After checking, connect the coupler to ECM securely.

Sensor	Terminal	Ohmmeter reading ( $\Omega$ )	Condition
Thermal switch	④	0	When coolant temp. is low.
		$\infty$	When coolant temp. is above 46.5°C (116°F).
Idle micro switch	⑮	0	When engine is warm and accelerator pedal is not depressed.
		$\infty$	When accelerator pedal is depressed a little.
High altitude compensator	⑭	$\infty$	When altitude is below 1,220 m (4,000 ft.).
		0	When altitude is above 1,220 m (4,000 ft.).
Thermal engine room switch	⑪	0	When temp. in engine room is low.
		$\infty$	When temp. in engine room is above 19.5°C (67°F).
Wide open micro switch	⑤	0	When accelerator pedal is not depressed or depressed only a little.
		$\infty$	When accelerator pedal is depressed all the way.
Fifth switch	⑲	$\infty$	When gear shift lever is shifted to low, second, third, fourth or reverse gear position.
		0	When gear shift lever is shifted to fifth gear position.

[Checking function of oxygen sensor and feed back system]

If the oxygen sensor fails to send signals to the ECM, the feed back system does not operate. While the feed back system is at work, the ECM sends out the feed back signal, and in this condition, when the cancel switch located on the steering column holder bracket is turned ON or the odometer indicates 60,000 or 120,000 miles, the "SENSOR" light in the instrument cluster flashes. If the "SENSOR" light does not flash in such conditions as described above, check the feed back system for function according to the following procedure.

- 1) Remove the ECM from the instrument main panel.
- 2) Connect the coupler to the ECM.  
(Don't disconnect the coupler from the ECM if connected)
- 3) Warm up the engine to the normal operating temperature and keep it at idle.
- 4) Connect voltmeter between the terminals ⑩ (oxygen sensor signal) and ⑪ (ground) as shown in below figure.
- 5) If the voltmeter indicator deflects between 0V and 0.8V while racing the engine at a speed between idling and 1,500 – 2,000 rpm, the feed back system is in good condition.

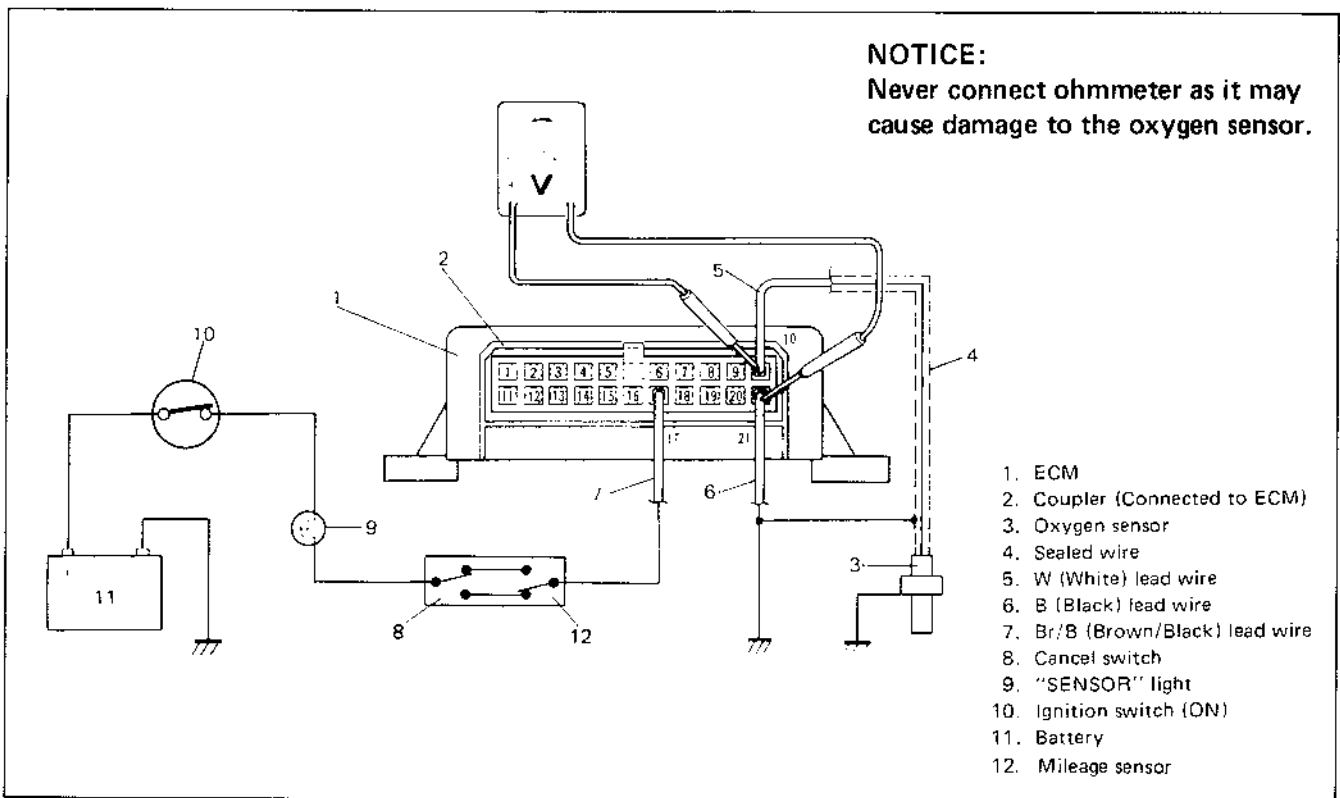


Fig. 5-3-44 Checking oxygen sensor signal

6) If the indicator does not deflect between 0V and 0.8V, possible causes are as follows.

Voltmeter indicator:	Possible causes
Remains at "Zero (0)"V	<ul style="list-style-type: none"> <li>● Oxygen sensor lead wire is disconnected or out of contact.</li> <li>● Intake system is leaky or air/fuel mixture is too lean due to malfunction of carburetor.</li> <li>● Inner resistance of voltmeter is too small.</li> <li>● Oxygen sensor is defective.</li> </ul>
Indicates about 0.8V and does not deflect.	<ul style="list-style-type: none"> <li>● Choke is operating because engine is not warmed up fully.</li> <li>● Thermal switch is defective.</li> <li>● Wide open micro switch is defective.</li> <li>● Lead wire of mixture control solenoid is disconnected.</li> <li>● Mixture control solenoid valve is defective.</li> </ul>

7) After it is confirmed through steps 1) to 5) that oxygen sensor sends signals to ECM properly, check feed back signal according to the following procedure. If feed back system operates properly, ECM should send out feed back signal.

a) Connect an ohmmeter between terminal ⑰ and body (ground). Be sure to connect positive (+) prod of the ohmmeter to body (ground) and negative (-) prod to terminal ⑰ as shown in below figure and never connect the other way around.

**NOTICE:**

For this check, cancel switch must be OFF ("SENSOR" light off).

b) If indicator of ohmmeter deflects when connected as described in the above step, it means that ECM sends out feed back signal, that is, feed back system operates properly.

**NOTICE:**

If indicator doesn't deflect at all, reverse connection (positive prod to terminal ⑰ and negative prod to body) and check.

In this state, turning ON cancel switch causes "SENSOR" light to flash. If "SENSOR" light does not flash, wire harness, bulb of light or cancel switch may be defective.

8) After checking, install ECM to instrument main panel, and make sure coupler is connected to ECM securely.

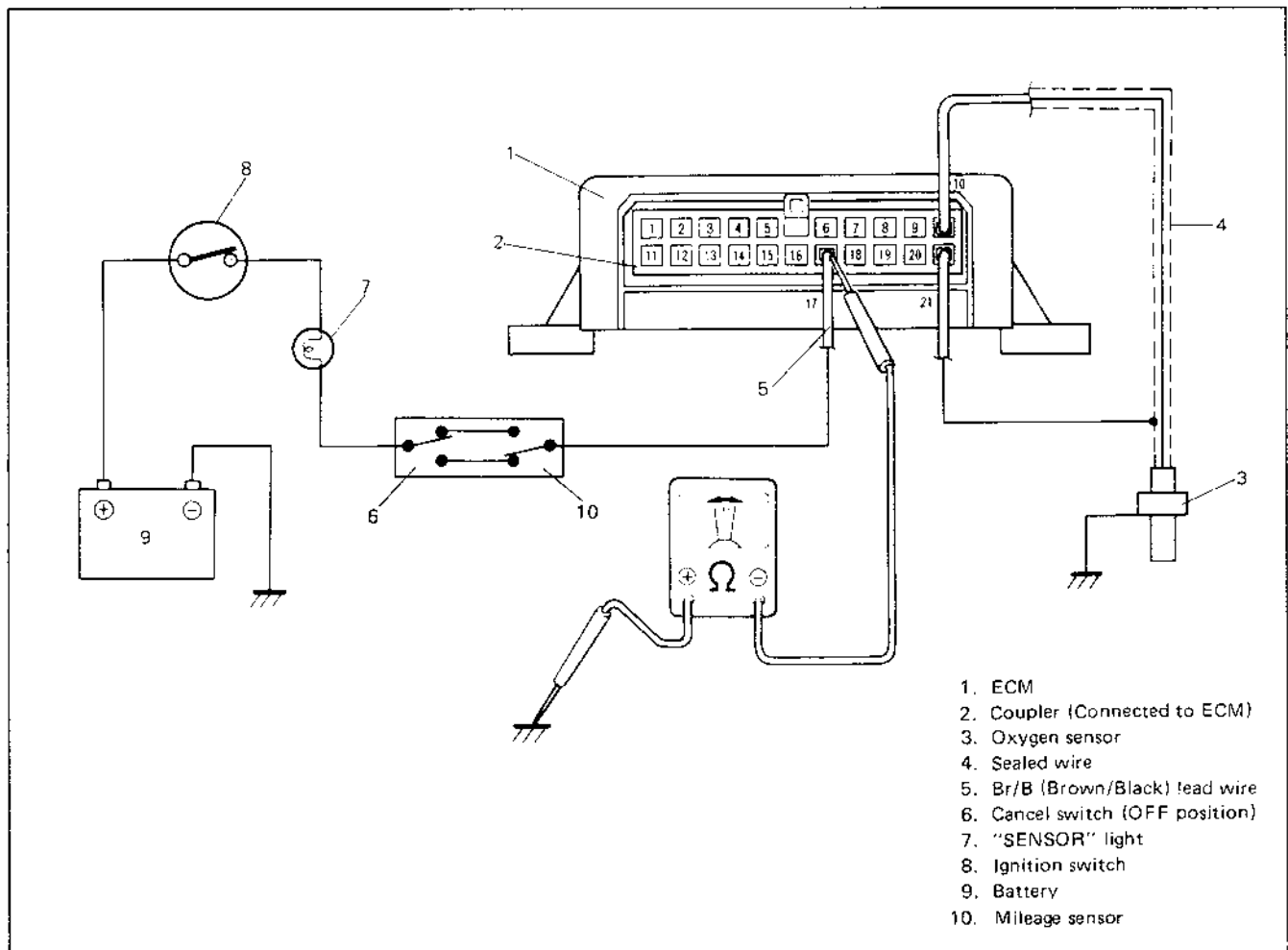


Fig. 5-3-45 Checking feed back signal

[Checking idle-up signal]

The idle-up system operates when any of the small lights (such as tail light, side marker light and license light), heater fan and rear defogger is put in operation. If the idle-up actuator fails to operate even when any of such equipments is put in operation, check if signal is sent to the ECM according to the following procedure.

- 1) Disconnect the coupler from the ECM.
- 2) Turn ON the ignition switch but don't run the engine.
- 3) Connect a voltmeter between the ⑦ terminal and the body (ground) as shown in below figure. If the voltmeter indicates 11 – 14V when each equipment is operated individually, it means that idle-up signal is sent to the ECM.  
If the voltmeter does not indicate 11 – 14V, the particular circuit is disconnected or in poor contact. Check the circuit for such conditions.
- 4) After checking, connect the coupler to ECM securely.

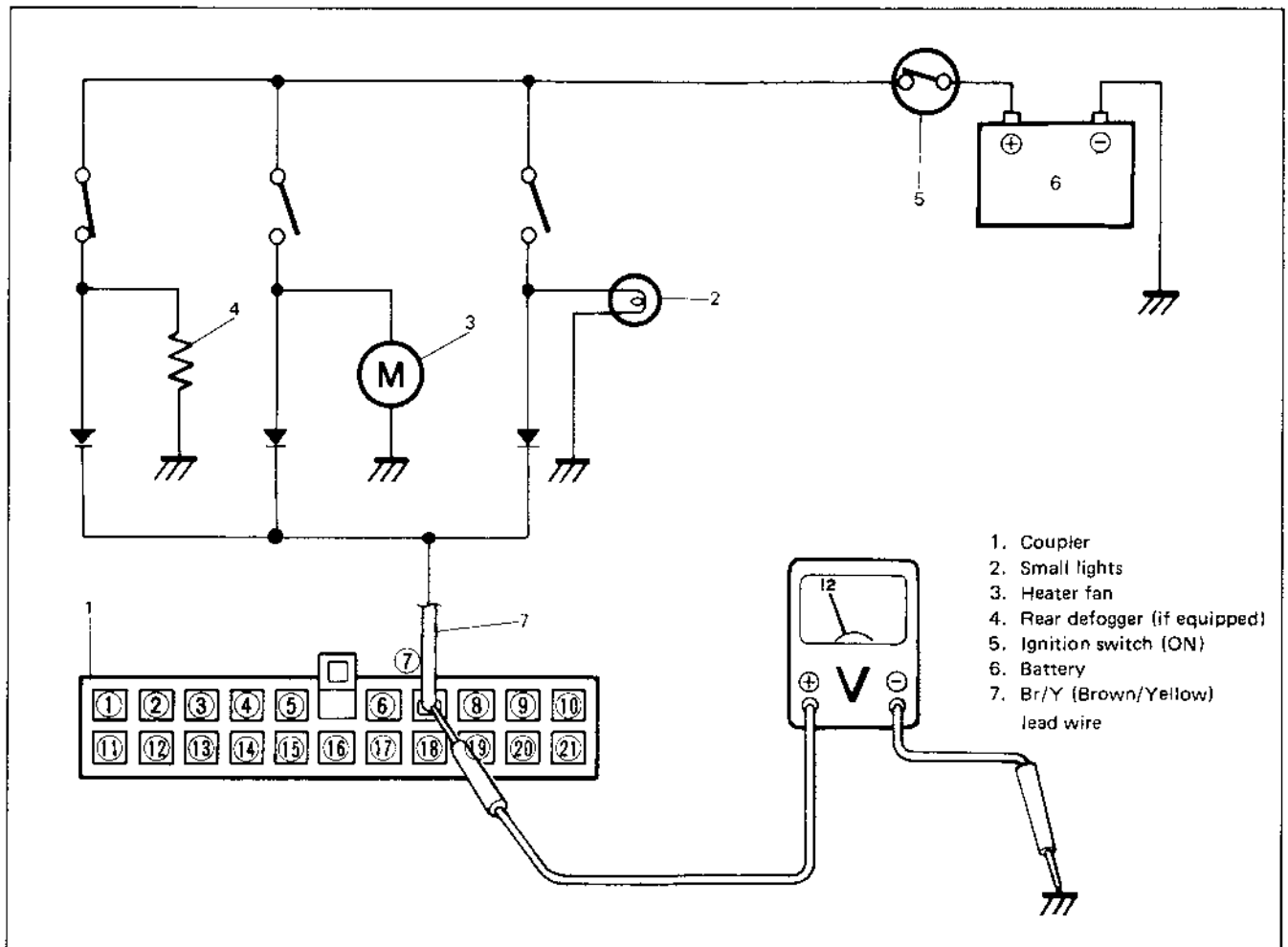


Fig. 5-3-46 Checking idle-up signal

### [Replacing ECM]

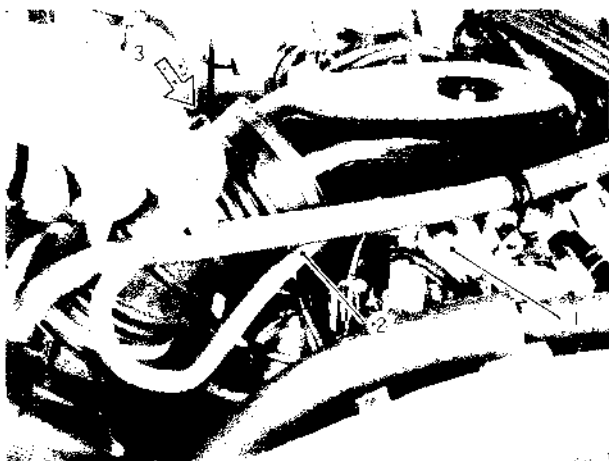
If a malfunction such as those listed below still occurs even after confirming proper function and condition of the sensors of the feedback system and their circuits through the above checks, a trouble may exist within the ECM. In such a case, replace the ECM.

- Fuel consumption increases even in normal driving.
- Engine tends to stall.
- Engine is hard to start.

### SWITCH VENT SOLENOID

#### Checking switch vent solenoid

- 1) Disconnect canister hose from switch vent solenoid and connect a new hose to the pipe of solenoid.
- 2) Blow air into new hose with ignition switch at both "OFF" and "ON" (but without starting engine) and check to be sure that air passes through solenoid in both cases.



1. Switch vent solenoid
2. Canister hose (new)
3. Blow air

Fig. 5-3-47 Checking switch vent solenoid

#### IMPORTANT:

Do not suck the hose. The fuel vapor in float chamber is harmful.

- 3) Start engine and run it at idle speed. Then check to be sure that air does not pass through solenoid when blowing air into new hose.
- 4) Remove new hose and connect original hose to switch vent solenoid.

### FUEL CUT SYSTEM

#### Checking fuel cut system

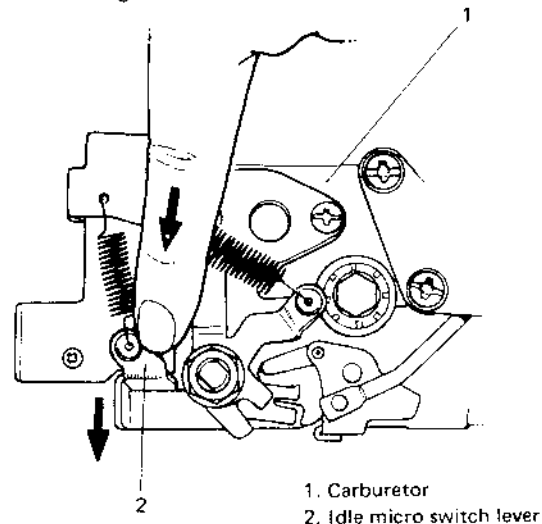
- 1) Make sure that fuel cut solenoid valve makes a clicking sound when ignition switch is turned to "ON" or "OFF" without cranking engine.



1. Carburetor
2. Fuel cut solenoid valve

Fig. 5-3-48 Fuel cut solenoid valve

- 2) Warm up engine to normal operating temperature.
- 3) Increase engine revolution to 3,000 – 3,500 rpm. Under these conditions, check to be sure that engine rpm changes when idle micro switch lever on carburetor is moved as shown in below figure.



1. Carburetor
2. Idle micro switch lever

Fig. 5-3-49 Idle micro switch lever

If found defective in above checks 1) and 3), check fuel cut solenoid circuit referring to item "checking feedback system circuits" in p. 5-29.



## EXHAUST GAS RECIRCULATION (EGR) SYSTEM

### Checking EGR system

#### NOTICE:

- Before checking, confirm that altitude is not higher than 1,220 m (4,000 ft) (atmospheric pressure is below 680mmHg) and gear shift lever is at neutral position.
- When performing this check at higher than 1,220 m (4,000 ft) altitude, be sure to disconnect HAC coupler.

- 1) Run engine when it is cool (coolant temperature is below 55°C (131°F)) and check that EGR valve diaphragm is not operating in this state, by touching diaphragm with finger.

#### IMPORTANT:

If EGR valve is hot, it may be necessary to wear gloves to avoid burning finger.

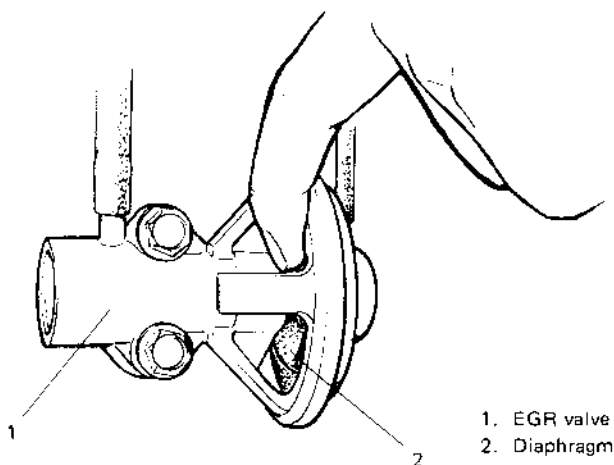


Fig. 5-3-50 Checking EGR valve diaphragm

- 2) Warm up engine to normal operating temperature and race it after warming up. Then check to be sure that diaphragm moves toward ① in below figure during acceleration and toward ② during deceleration.

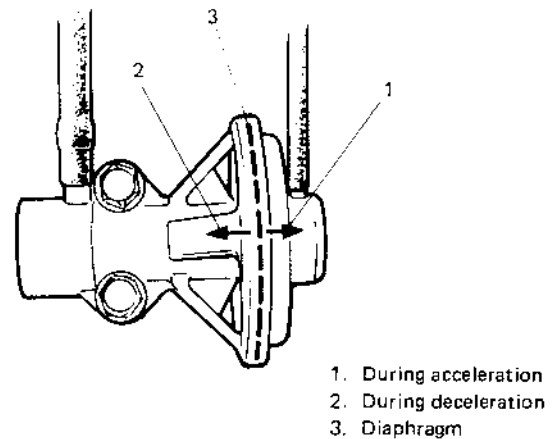


Fig. 5-3-51 Movement of EGR valve diaphragm

If found defective in above step 1) or 2), inspect following parts according to each procedure.

#### NOTICE:

Refer to item "CHECKING SENSOR AND THEIR LEAD WIRES" in page 5-32 for checking HAC, fifth switch and their circuit.

#### [Vacuum hoses]

Check hoses for connection, leakage, clog and deterioration. Replace as necessary.

#### [EGR valve]

- 1) Disconnect vacuum hose from TWSV.
- 2) Connect vacuum pump gauge to its hose.
- 3) Check that EGR valve diaphragm moves smoothly and that it is held at the same position when more than 20 cmHg vacuum is applied to EGR valve.

If diaphragm doesn't move smoothly, or it isn't held at the same position, replace EGR valve.

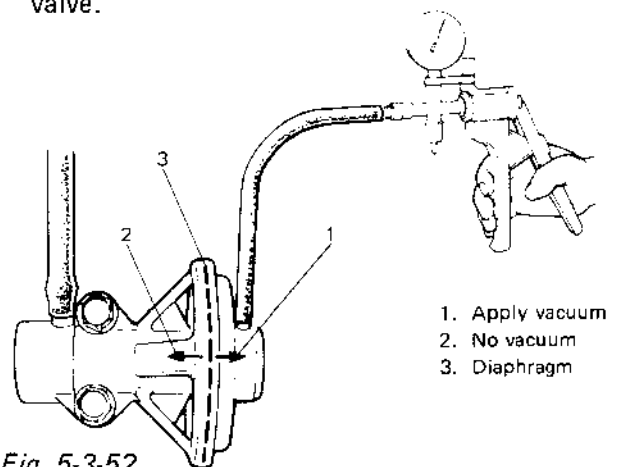


Fig. 5-3-52

- 4) After checking, be sure to connect vacuum hose to TWSV.

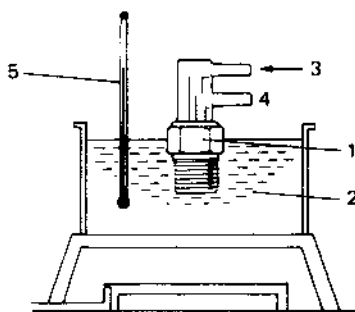
[Bi-metal vacuum switching valve (BVSV)]

**NOTICE:**

For the rough check of the operation, BVSV can be checked by warming up or cooling down the engine without being removed from the intake manifold.

The check procedure is the same as the following except item 1), 2) and 5).

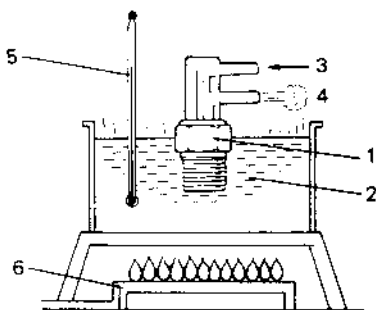
- 1) Drain cooling system when engine is cold.
- 2) Disconnect vacuum hoses and remove BVSV from intake manifold.
- 3) While keeping BVSV cool (below 53°C (127°F)), blow nozzle "3". Air should not come out of nozzle "4".



1. BVSV
2. Cool water
3. Blow air (nozzle)
4. "No air" (nozzle)
5. Thermometer

Fig. 5-3-53 Checking BVSV (1)

- 4) While keeping BVSV warm (above 65°C (149°F)) in hot water, blow nozzle "3". Air should come out of nozzle "4".



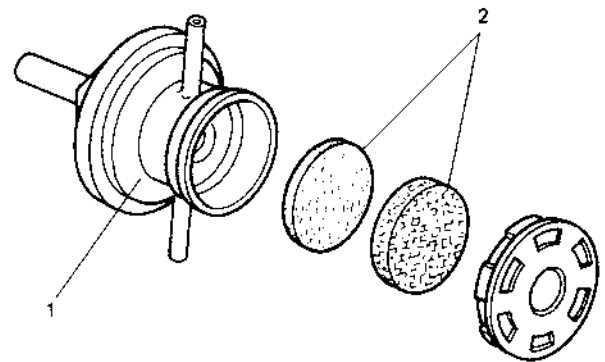
1. BVSV
2. Hot water
3. Blow air (nozzle)
4. Air (nozzle)
5. Thermometer
6. Heater

Fig. 5-3-54 Checking BVSV (2)

- 5) Reinstall BVSV to intake manifold. Before installing, wind sealing tape on its thread.
- 6) Connect vacuum hoses.

[EGR modulator]

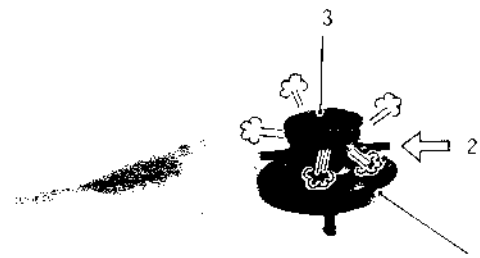
- 1) Check filter for contamination and damage. Using compressed air, clean filter.



1. EGR modulator
2. Filter

Fig. 5-3-55 Filter of EGR modulator

- 2) Remove EGR modulator and plug nozzle with your finger. Blow air into another nozzle and check that air passes through to air filter side freely.



1. EGR modulator
2. Blow air
3. Air filter

Fig. 5-3-56 Checking EGR modulator (1)

- 3) Connect vacuum pump gauge to nozzle ① and plug nozzle ② with your finger. While blowing air into nozzle ③, operate vacuum pump gauge and check that vacuum is applied to modulator then.

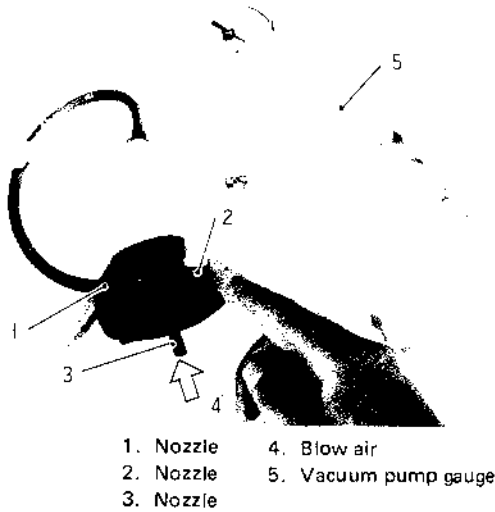


Fig. 5-3-57 Checking EGR modulator (2)

- 4) After checking, install modulator and connect hoses securely. Refer to Fig. 5-1-1 for connecting.

[Three way solenoid valve (TWSV)]

- 1) Disconnect 2 vacuum hoses from EGR modulator and EGR valve.
- 2) Blow hose ①. Air should come out of hose ② and not out of filter.

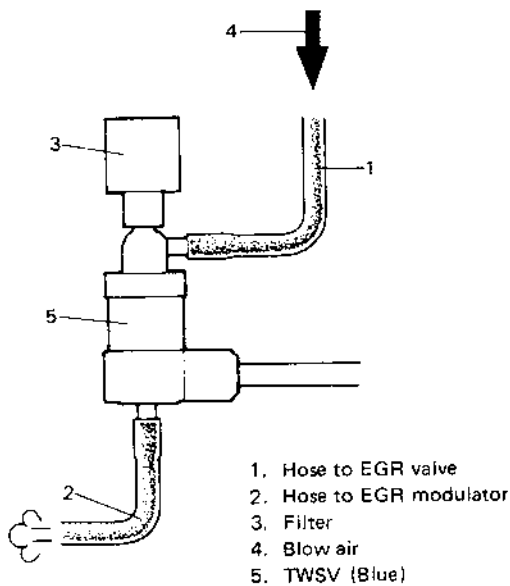


Fig. 5-3-58

- 3) Disconnect coupler and connect 12V-battery to TWSV terminals. In this state, blow hose ①. Air should come out of filter and not out of hose ②.

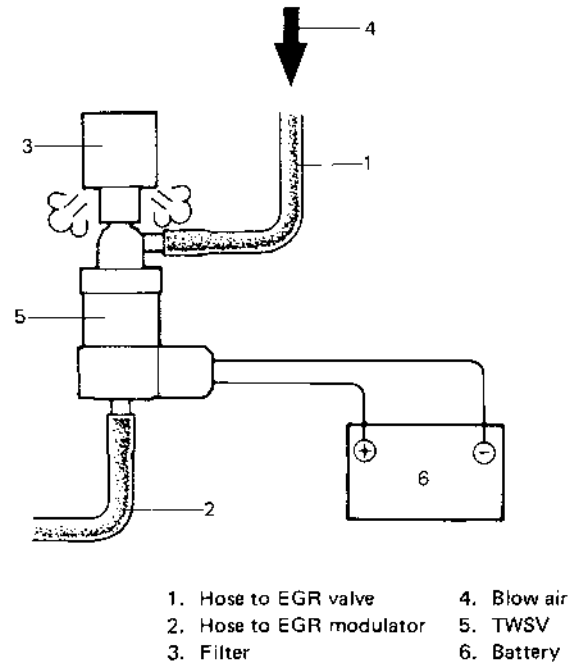


Fig. 5-3-59

- 4) After checking, be sure to connect vacuum hoses and coupler.



**SECTION 6**  
**ENGINE COOLING SYSTEM**

**CONTENTS**

<b>6-1.</b>	<b>GENERAL DESCRIPTION</b> .....	<b>6-2</b>
<b>6-2.</b>	<b>REMOVAL</b> .....	<b>6-5</b>
<b>6-3.</b>	<b>INSPECTION OF COMPONENTS</b> .....	<b>6-7</b>
	<b>THERMOSTAT</b> .....	<b>6-7</b>
	<b>RADIATOR</b> .....	<b>6-8</b>
	<b>WATER PUMP</b> .....	<b>6-8</b>
<b>6-4.</b>	<b>IMPORTANT STEPS FOR REINSTALLATION</b> .....	<b>6-9</b>
	<b>WATER PUMP</b> .....	<b>6-9</b>
	<b>THERMOSTAT</b> .....	<b>6-9</b>
	<b>COOLING FAN AND WATER PUMP BELT</b> .....	<b>6-9</b>
	<b>RADIATOR</b> .....	<b>6-10</b>
<b>6-5.</b>	<b>MAINTENANCE SERVICE</b> .....	<b>6-10</b>
	<b>WATER PUMP BELT</b> .....	<b>6-10</b>
	<b>COOLANT</b> .....	<b>6-11</b>
	<b>COOLANT LEVEL</b> .....	<b>6-11</b>
	<b>COOLING SYSTEM SERVICE</b> .....	<b>6-12</b>
	<b>COOLING SYSTEM, FLUSH AND REFILL</b> .....	<b>6-12</b>

## 6-1. GENERAL DESCRIPTION

The cooling system consists of the radiator cap, radiator, water reservoir tank, hoses, water pump, cooling fan & clutch, thermostat. The radiator is of tube-and-fin type.

### Cooling System Circulation

During engine warm-up (thermostat closed), the water pump discharges coolant into the water jacket chamber adjacent to No. 1 cylinder. Coolant then flows through the cylinder block and the cylinder head. Coolant then returns to the water pump through intake manifold, heater inlet hose, heater unit, heater outlet hose, and water intake pipe.

During normal temperatures (thermostat open), coolant takes the same basic route but is now allowed to flow past the thermostat, the inlet hose and the radiator, and then back to the water pump through the outlet hose and the water intake pipe.

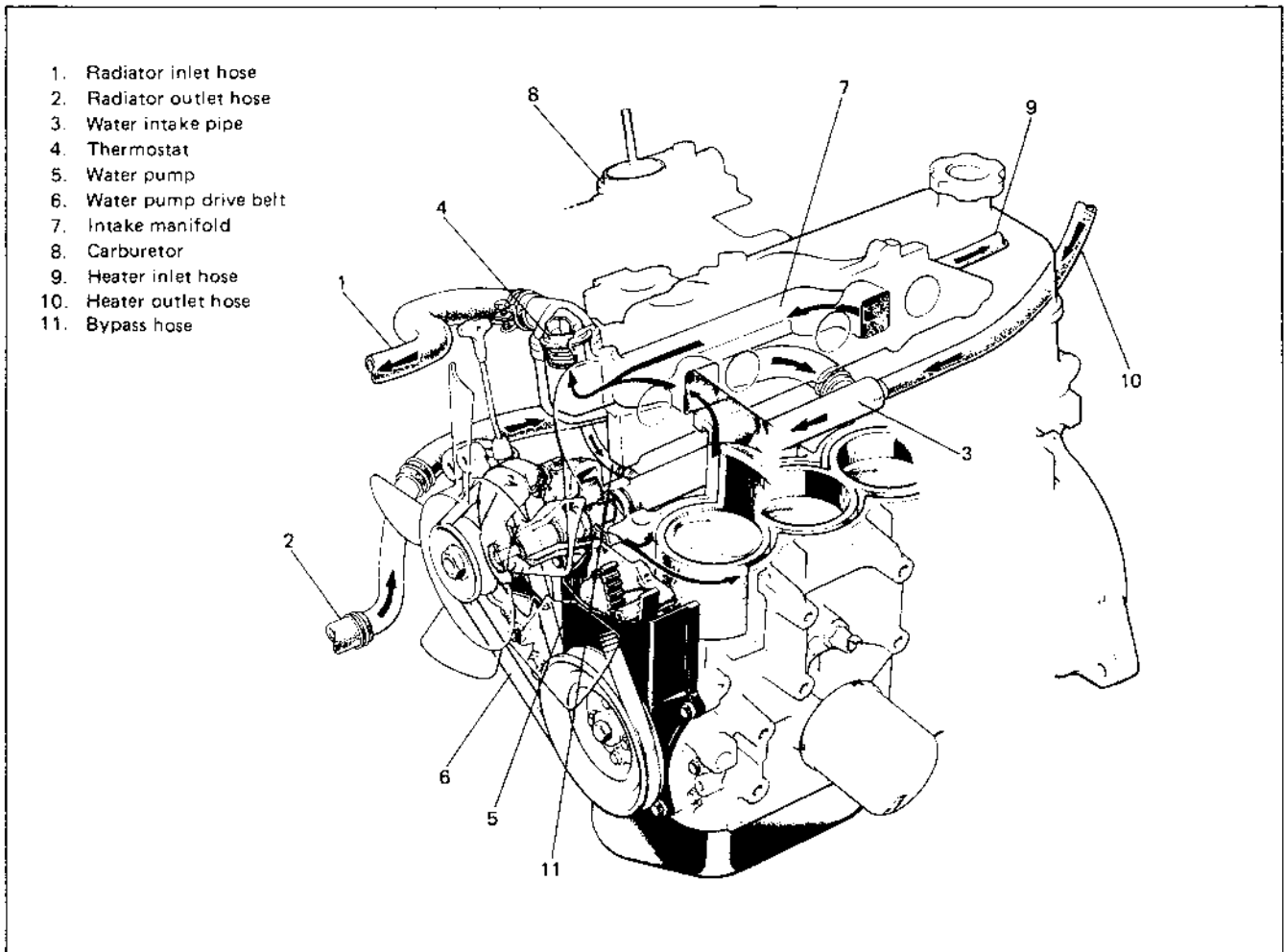


Fig. 6-1 Cooling system

## Radiator Cap

A pressure-vent cap is used on the radiator. The cap contains a pressure valve and vacuum valve. The pressure valve is held against its seat by a spring of pre-determined strength which protects the cooling system by relieving the pressure if the pressure in cooling system rises by 0.9 kg/cm<sup>2</sup> (12.8 psi, 90 kPa). The vacuum valve is held against its seat by a light spring which permits opening of the valve to relieve vacuum created in the system when it cools off and which otherwise might cause the radiator to collapse.

The cap has its face marked 0.9, which means that its pressure valve opens at 0.9 kg/cm<sup>2</sup> (12.8 psi, 90 kPa).

### NOTICE:

Do not remove radiator cap to check engine coolant level; check coolant visually the see-through water reservoir tank.

Coolant should be added only to reservoir tank as necessary.

### WARNING:

As long as there is pressure in the cooling system, the temperature can be considerably higher than the boiling temperature of the solution in the radiator without causing the solution to boil. Removal of the radiator cap while engine is hot and pressure is high will cause the solution to boil instantaneously and possibly with explosive force, spewing the solution over engine, fenders and person removing cap. If the solution contains flammable anti-freeze such as alcohol (not recommended for use at any time), there is also the possibility of causing a serious fire.

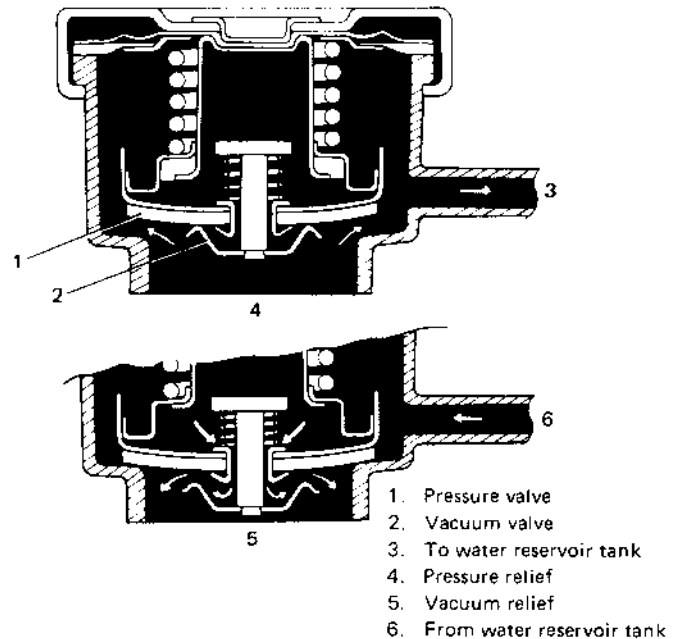


Fig. 6-2

## Water Reservoir Tank

A "see-through" plastic reservoir tank is connected to the radiator by a hose. As the car is driven, the coolant is heated and expands. The portion of the coolant displaced by this expansion flows from the radiator into the reservoir tank.

When the car is stopped and the coolant cools and contracts, the displaced coolant is drawn back into the radiator by vacuum.

Thus, the radiator is kept filled with coolant to the desired level at all times, resulting in increased cooling efficiency.

Coolant level should be between "FULL" and "LOW" marks on the reservoir tank.

Coolant should be added only to the reservoir tank as necessary.

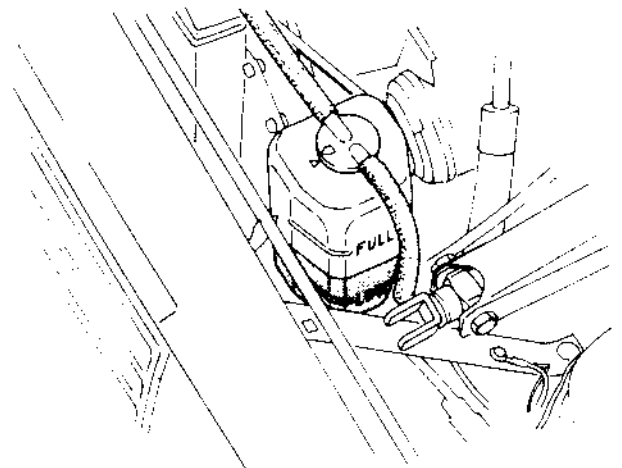


Fig. 6-3 Water reservoir tank

## Water Pump

The centrifugal type water pump is used in the cooling system. The pump impeller is supported by a totally sealed bearing. The water pump can not be disassembled.

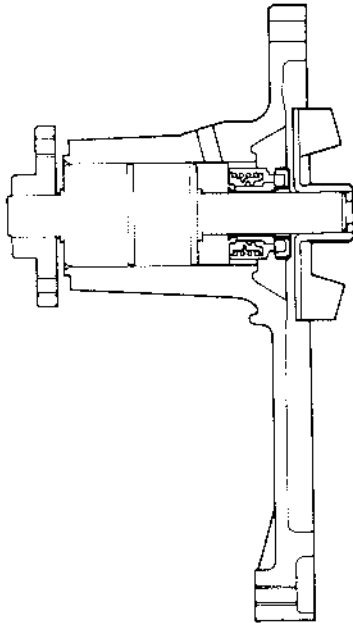


Fig. 6-4

## Thermostat

A wax pellet type thermostat is used in the coolant outlet passage to control the flow of engine coolant, to provide fast engine warm up and to regulate coolant temperatures.

A wax pellet element is hermetically contained in a metal case, and expands when heated and contracts when cooled.

When the pellet is heated and expands, the metal case pushes down the valve to open it.

As the pellet is cooled, the contraction allows a spring to close the valve.

Thus, the valve remains closed while the coolant is cold, preventing circulation of coolant through the radiator.

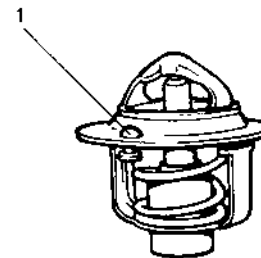
At this point, coolant is allowed to circulate only throughout the engine to warm it quickly and evenly.

As the engine warms, the pellet expands and the thermostat valve opens, permitting coolant to flow through the radiator.

In the top portion of the thermostat, an air bleed valve is provided; this valve is for venting out the gas or air, if any, that is accumulated in the circuit.

There are two types of thermostat, A and B, as given below. Either one is used depending on vehicle specifications. The temperature at which the valve begins to open is stamped on each thermostat. Be sure to note this stamped temperature for replacement.

Thermostat functional spec. $\pm 1.5^{\circ}\text{C}$ ( $2.7^{\circ}\text{F}$ )		
	Thermostat "A"	Thermostat "B"
Temp. at which valve begins to open	$82^{\circ}\text{C}$ ( $179^{\circ}\text{F}$ )	$88^{\circ}\text{C}$ ( $190^{\circ}\text{F}$ )
Temp. at which valve become fully open	$95^{\circ}\text{C}$ ( $203^{\circ}\text{F}$ )	$100^{\circ}\text{C}$ ( $212^{\circ}\text{F}$ )
Valve lift	More than 8 mm at $95^{\circ}\text{C}$	More than 8 mm at $100^{\circ}\text{C}$



1. Air bleed valve

Fig. 6-5 Thermostat



## 6-2. REMOVAL

### WARNING:

- Check to make sure that cooling water temperature is cold before removing any part of cooling system components.
- Also be sure to disconnect  $\ominus$  cord from battery  $\ominus$  terminal before removing any part.

### 1. Coolant Draining

- 1) Remove radiator cap.
- 2) Loosen drain plug ① on radiator to empty its water side.

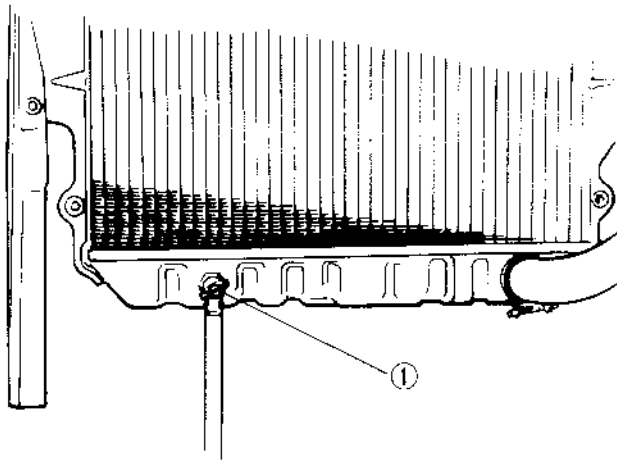


Fig. 6-6

### 2. Cooling Water Pipes or Hoses

- 1) Drain cooling system.
- 2) To remove these pipes or hoses, loosen screw on each pipe or hose clip and pull hose end off.

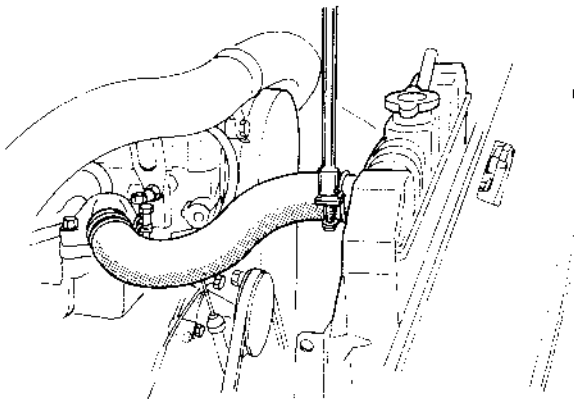


Fig. 6-7

### 3. Water Pump Drive Belt

- 1) Loosen water pump drive belt tension.
- 2) Remove belt.

### 4. Cooling Fan, Fan Clutch and Water Pump Pulley

- 1) Remove radiator shroud securing bolts (4 pcs) and cooling fan securing nuts (or bolts, 4 pcs).

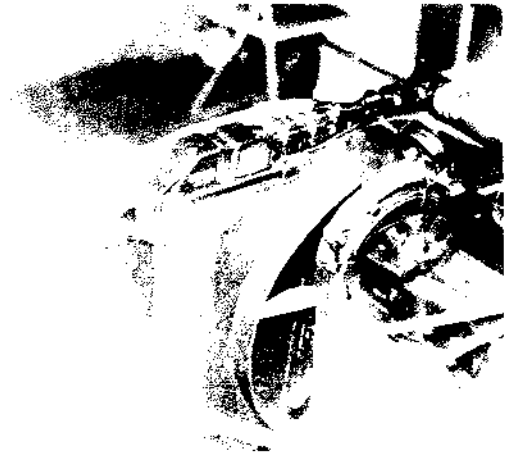


Fig. 6-8

- 2) Then remove radiator shroud and cooling fan and/or fan clutch and water pump pulley at the same time.

### 5. Radiator

- 1) Drain cooling system.
- 2) Loosen water pump drive belt tension.
- 3) Remove radiator shroud and cooling fan & clutch at the same time.
- 4) Disconnect water hoses from radiator.
- 5) Remove radiator.



Fig. 6-9

## 6. Thermostat

- 1) Drain cooling system.
- 2) Disconnect thermostat cap from intake manifold.

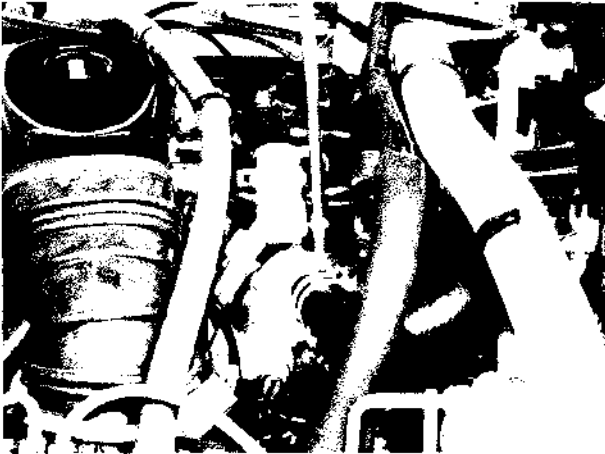


Fig. 6-10

- 3) Remove thermostat.

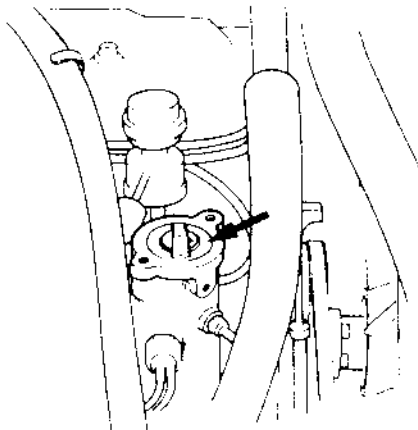
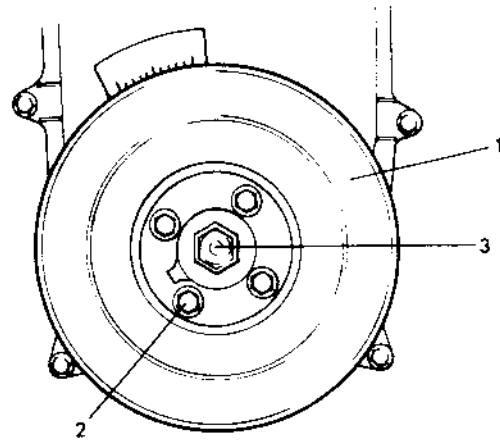


Fig. 6-11

## 7. Water Pump

- 1) Drain cooling system.  
Refer to 1. Coolant draining on previous page.
- 2) Remove the radiator shroud and cooling fan & clutch at the same time.  
Refer to item 4 on previous page.
- 3) Loosen water pump drive belt tension.  
Then remove water pump pulley and pump drive belt.
- 4) Remove crankshaft pulley by removing 4 pulley bolts. Crankshaft timing belt pulley bolt at the center is needs not to be loosened.



1. Crankshaft pulley
2. Crankshaft pulley bolt
3. Crank timing belt pulley bolt

Fig. 6-12

- 5) Remove timing belt outside cover.



Fig. 6-13

6) Loosen tensioner bolt and stud, and remove belt from crank timing belt pulley and camshaft pulley after pushing up tensioner plate fully with finger as shown in Figure.

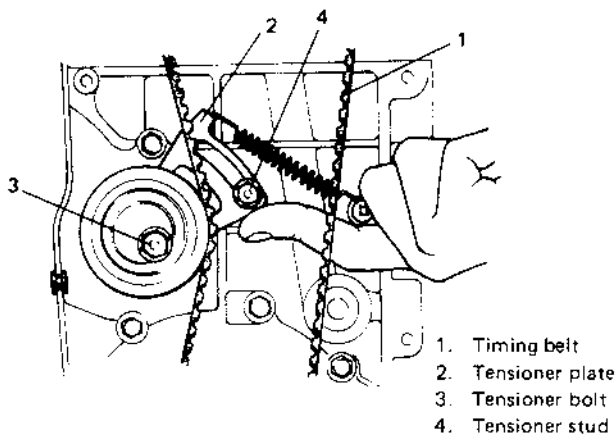
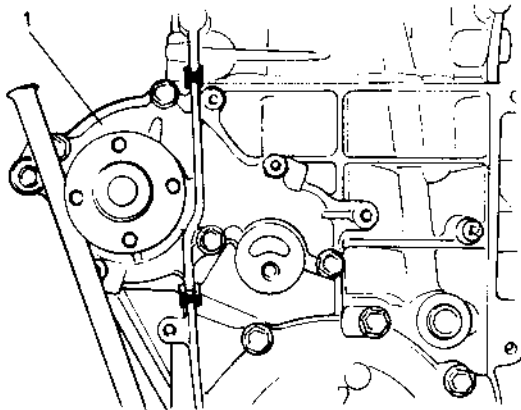


Fig. 6-14

- 7) Remove timing belt tensioner, plate and spring.
- 8) Remove water pump assembly.



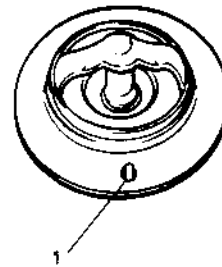
1. Water pump

Fig. 6-15

### 6-3. INSPECTION OF COMPONENTS

#### Thermostat

- 1) Make sure that air bleed valve of thermostat is clear. Should this valve be clogged, engine would tend to overheat.

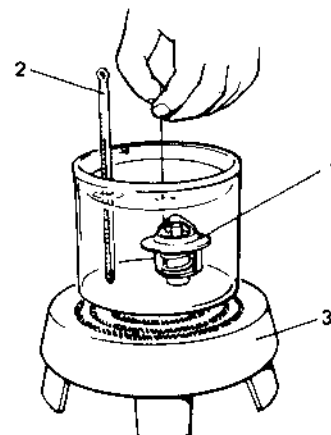


1. Air bleed valve

Fig. 6-16

- 2) Check valve seat for some foreign matters being stuck which prevent valve from seating tight.
- 3) Check thermostatic movement of wax pellet as follows:

- Immerse thermostat in water, and heat water gradually.
- Check that valve starts to open at specification temp.
- If valve starts to open at a temperature substantially below or above, thermostat unit should be replaced with a new one. Such a unit, if re-used, will bring about overcooling or overheating tendency.



1. Thermostat  
2. Thermometer  
3. Heater

Fig. 6-17

## Radiator

If the water side of the radiator is found excessively rusted or covered with scales, clean it by flushing with the radiator cleaner compound. This flushing should be carried out at regular intervals for scale or rust formation advances with time even where a recommended type of coolant is used. Periodical flushing will prove more economical.

Inspect the radiator cores and straighten the flattened or bent fins, if any. Clean the cores, removing road grimes and trashes.

Excessive rust or scale formation on the wet side of the radiator lowers the cooling efficiency. Flattened or bent fins obstruct the flow of air through the core to impede heat dissipation.

Radiator flushing interval	Two years (recommended)
----------------------------	-------------------------

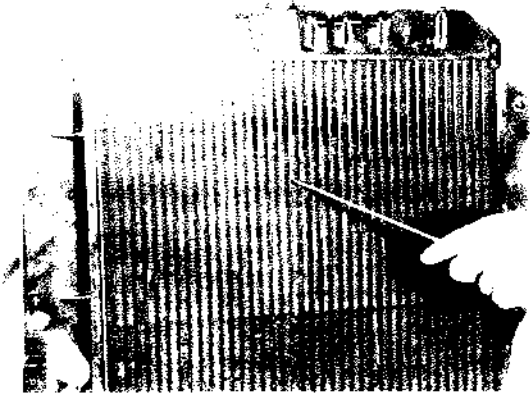


Fig. 6-18

## Water Temperature Gauge

For gauge inspection, refer to SECTION 21 BODY ELECTRICAL EQUIPMENT of this manual.

## Water Pump

### NOTICE:

**Do not disassemble water pump.**

**If any repair is required on pump, replace it as assembly.**

- Rotate water pump by hand to check for smooth operation.  
If pump does not rotate smoothly or makes an abnormal noise, replace it.

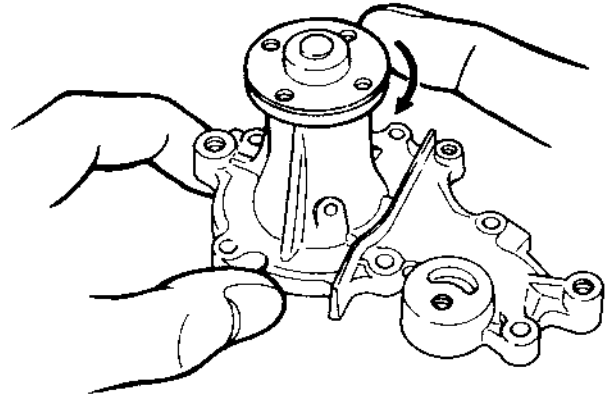


Fig. 6-19

## 6-4. IMPORTANT STEPS FOR REINSTALLATION

### Water Pump

- 1) Install new pump gasket to cylinder block.
- 2) Install water pump to cylinder block.

Tightening torque for bolts & nuts	10 – 13 N·m 1.0 – 1.3 kg·m 7.5 – 9.0 lb·ft
------------------------------------	--

After installing water pump, install rubber seal between water pump and oil pump, and another between water pump and cylinder head.

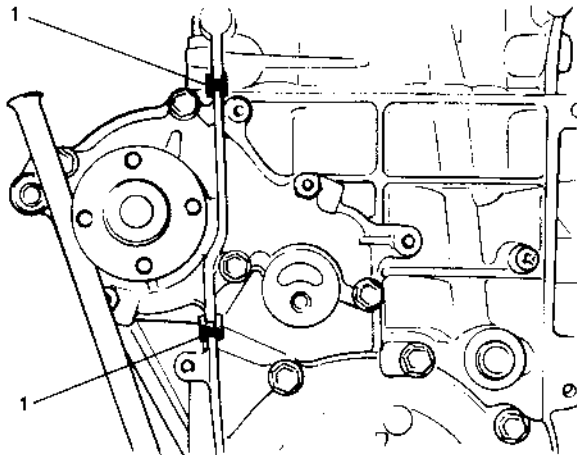


Fig. 6-20

1. Rubber seal

- 3) Install belt tensioner plate, tensioner, tensioner spring, timing belt and timing belt outside cover.

### NOTICE:

- Special care must be used when installing belt tensioner and timing belt. Be sure to refer to p. 3-48 of this manual.
  - Torque each bolt and nut to specification.
- 4) Install crankshaft pulley, water pump pulley, pump drive belt, cooling fan & clutch and radiator shroud.
  - 5) Adjust intake and exhaust valve lashes.  
(For adjustment and related data, refer to p. 3-53 of this manual).
  - 6) Adjust water pump belt tension.  
(Refer to P. 6-10).
  - 7) Connect negative cable at battery.
  - 8) Fill the cooling system.

### Thermostat

- 1) When positioning the thermostat on the intake manifold, be sure to bring its air breather valve ① to front side of the engine.

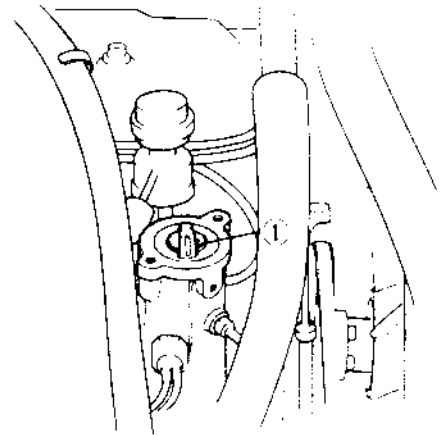


Fig. 6-21

- 2) Install new gasket and thermostat cap to intake manifold.
- 3) Fill the cooling system.

### Cooling Fan, Fan clutch and Water Pump Belt

Once cooling fan, fan clutch or water pump belt has been removed, make sure to tighten bolts and nuts securely in reinstallation and adjust pump belt tension to specification. (For specified tension, refer to p. 6-10.)

## Radiator

- 1) Tighten bolts securely for proper installation. Also, fix joints of 2 hoses with clamps.

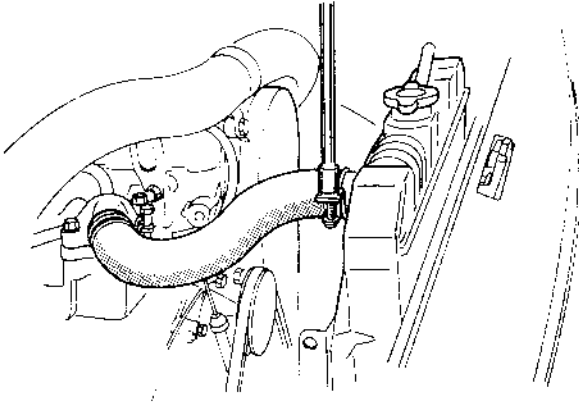


Fig. 6-22

- 2) Install radiator shroud and cooling fan & clutch at the same time.
- 3) Tighten shroud bolts and fan clutch nuts.
- 4) Adjust water pump belt tension.
- 5) Fill specified amount of coolant.

## 6-5. MAINTENANCE SERVICE

### Water Pump Belt

- 1) Inspect belt for cracks, cuts, deformation, wear and cleanliness. If it is necessary to replace belt, refer to p6-5 for procedure.
- 2) Check belt for tension. Belt is in proper tension when it deflects 6 to 9 mm (0.24 – 0.35 in.) under thumb pressure (about 10 kg or 22 lb.).

Belt tension specification	6 – 9 mm (0.24 – 0.35 in.) as deflection
----------------------------	--

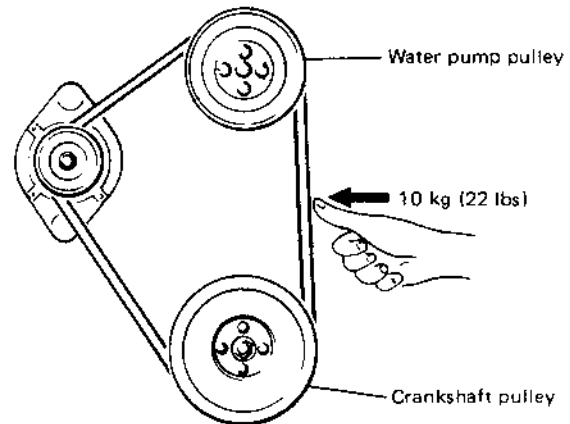


Fig. 6-23

- 3) If belt is too tight or too loose, adjust it to proper tension by displacing alternator position.

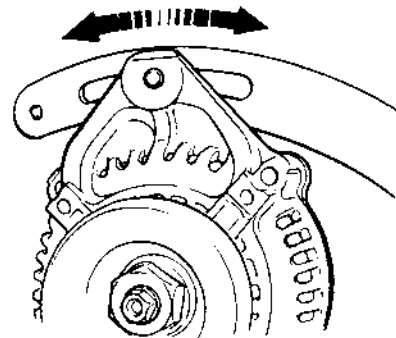


Fig. 6-24

- 4) Tighten alternator adjusting bolt and pivot bolt.

### WARNING:

All adjustments described above are to be performed with ENGINE NOT RUNNING.

## Coolant

The coolant recovery system is standard. The coolant in the radiator expands with heat, and the overflow is collected in the reservoir tank.

When the system cools down, the coolant is drawn back into the radiator.

The cooling system has been filled at the factory with a quality coolant that is either 50/50 mixture of water and GOLDEN CRUISER 1200, 99000-24120 (ethylene glycol antifreeze.) or 30/70 mixture of water and GOLDEN CRUISER 1200.

The 50/50 mixture coolant solution provides freezing protection to  $-36^{\circ}\text{C}$  ( $-33^{\circ}\text{F}$ ), the 30/70 mixture coolant solution provides freezing protection to  $-16^{\circ}\text{C}$  ( $3^{\circ}\text{F}$ ).

### GOLDEN CRUISER 1200 – “Anti-freeze and Summer Coolant” – its effects

- 1) Its freezing temperature is much lower and depends on the concentration of GOLDEN CRUISER 1200. It is an anti-freeze coolant.
- 2) It does not corrode the metal surfaces of the cooling circuit. It is an anti-corrosion coolant.
- 3) It does not develop foam or bubbles. It is a foam-inhibited coolant.

When changing the engine coolant, use mixture of 50% water and 50% GOLDEN CRUISER 1200 for the market where ambient temperature falls lower than  $-16^{\circ}\text{C}$  ( $3^{\circ}\text{F}$ ) in winter and mixture of 70% water and 30% GOLDEN CRUISER 1200 for the market where ambient temperature doesn't fall lower than  $-16^{\circ}\text{C}$  ( $3^{\circ}\text{F}$ ).

ANTI-FREEZE PROPORTIONING CHART

Freezing Temperature	$^{\circ}\text{C}$	-16	-36
	$^{\circ}\text{F}$	3	-33
GOLDEN CRUISER Concentration	%	30	50
Ratio of compound to cooling water	ltr.	1.50/3.50	2.50/2.50
	US pt.	3.17/7.39	5.28/5.28
	Imp. pt.	2.64/6.16	4.40/4.40

COOLANT CAPACITY	
Engine, radiator and heater	4.4 liters (9.3/7.7 US/Imp pt.)
Reservoir tank	0.6 liters (1.3/1.1 US/Imp pt.)
Total	5.0 liters (10.6/8.8 US/Imp pt.)

### NOTICE:

- Alcohol or methanol base coolants or plain water alone should not be used in cooling system at any time, as damage to cooling system could occur.
- Even in a market where no freezing temperature is anticipated, mixture of 70% water and 30% GOLDEN CRUISER 1200 should be used for the purpose of corrosion protection and lubrication.

### Coolant Level

To check level, lift hood and look at “see through” water reservoir tank.

It is not necessary to remove radiator cap to check coolant level.

### WARNING:

To help avoid danger of being burned:

- do not remove reservoir tank cap while coolant is “boiling”, and
- do not remove radiator cap while engine and radiator are still hot.

Scalding fluid and steam can be blown out under pressure if either cap is taken off too soon.

When engine is cool, check coolant level in reservoir tank. A normal coolant level should be between “FULL” and “LOW” marks on reservoir tank.

If coolant level is below “LOW” mark, remove reservoir tank cap and add proper coolant to tank to bring coolant level up to “FULL” mark. Then, reinstall cap aligning the arrow marks on the tank and cap.

### NOTICE:

If proper quality antifreeze is used, there is no need to add extra inhibitors or additives that claim to improve system. They may be harmful to proper operation of system, and are unnecessary expense.

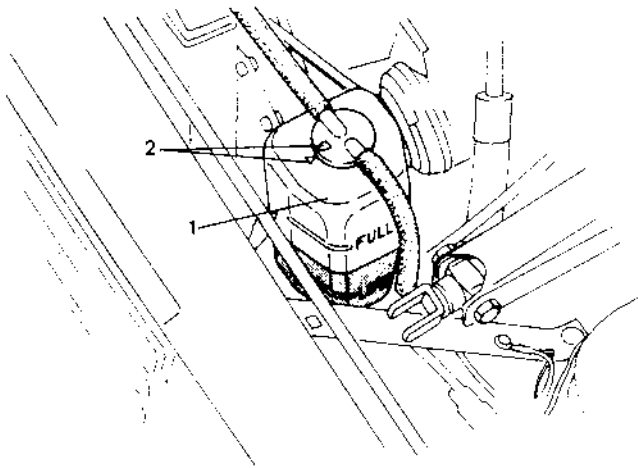


Fig. 6-25

### Cooling System Service

Cooling system should be serviced as follows.

- 1) Check cooling system for leaks or damage.
- 2) Wash radiator cap and filler neck with clean water by removing radiator cap when engine is cold.
- 3) Check coolant for proper level and freeze protection.
- 4) Using a pressure tester, check system and radiator cap for proper pressure holding capacity 0.9 kg/cm<sup>2</sup> (12.8 psi, 90 kPa). If replacement of cap is required, use proper cap specified for this vehicle.
- 5) Tighten hose clamps and inspect all hoses. Replace hoses whenever cracked, swollen or otherwise deteriorated.
- 6) Clean frontal area of radiator core.

### NOTICE:

After installing radiator cap ① to radiator, make sure that its ear ② is aligned with reservoir tank hose ③ as shown in Figure. If not, turn cap more to align its ear with hose.

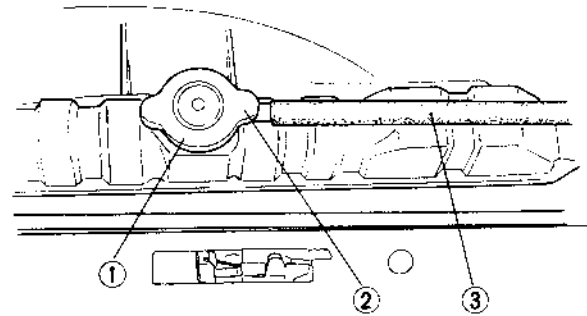


Fig. 6-26 Installation of radiator cap

### Cooling System, Flush and Refill

- 1) Remove radiator cap when engine is cool:

#### WARNING:

To help avoid danger of being burned, do not remove radiator cap while engine and radiator are still hot. Scalding fluid and steam can be blown out under pressure if cap is taken off too soon.

- 2) With radiator cap removed, run engine until upper radiator hose is hot (this shows that thermostat is open and coolant is flowing through system).
- 3) Stop engine and open radiator drain plug ① to drain coolant.

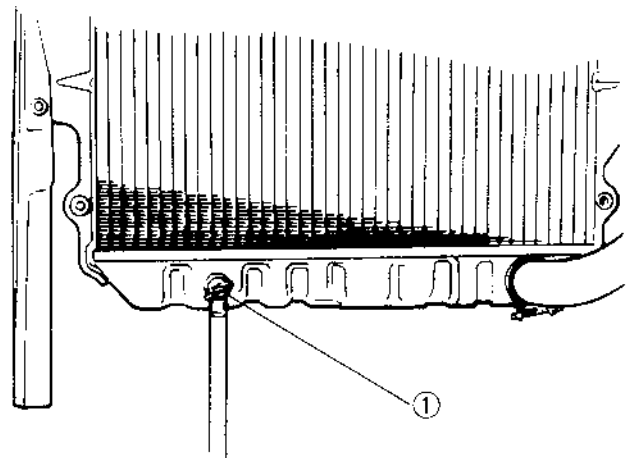


Fig. 6-27 Radiator drain plug



- 4) Close drain plug. Add water until system is filled and run engine until upper radiator hose is hot again.
- 5) Repeat steps 3) and 4) several times until drained liquid is nearly colorless.
- 6) Drain system and then close radiator drain plug tightly.
- 7) Disconnect hose from water reservoir tank. Remove tank and pour out any fluid. Scrub and clean inside of tank with soap and water. Flush it well with clean water and drain. Reinstall tank and hose.
- 8) Add proper mixture coolant (refer to page 6-11) of GOLDEN CRUISER 1200, 99000-24120 (good quality ethylene glycol anti-freeze) and water to radiator and tank. Fill radiator to the base of radiator filler neck and reservoir tank to "FULL" level mark. Reinstall reservoir tank cap, aligning the arrow marks on the tank and cap.
- 9) Run engine, with radiator cap removed, until radiator upper hose is hot.
- 10) With engine idling, add coolant to radiator until level reaches the bottom of filler neck. Install radiator cap, making sure that the ear of cap lines up with reservoir tank hose.

### Cooling Fan Clutch

Inspect fluid coupling for oil leakage.

If necessary, replace fan clutch assembly. Do not disassemble clutch assembly.

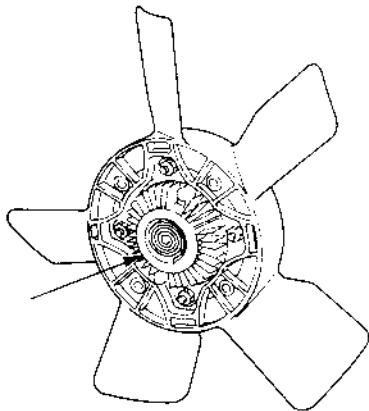


Fig. 6-28



## SECTION 7

# CAR HEATER

### CONTENTS

7-1.	DESCRIPTION .....	7-2
7-2.	ELECTRICAL CIRCUIT .....	7-3
7-3.	HEATER SERVICES .....	7-4
7-4.	REMOVAL AND INSTALLATION .....	7-5

## 7-1. DESCRIPTION

The car heater is of a hot water type and operates quietly. The air is heated by the engine coolant and the warm air is blown into the car interior by the blower motor. The blower motor is driven electrically, independent of engine speed, and operates effectively even when the engine speed is low.

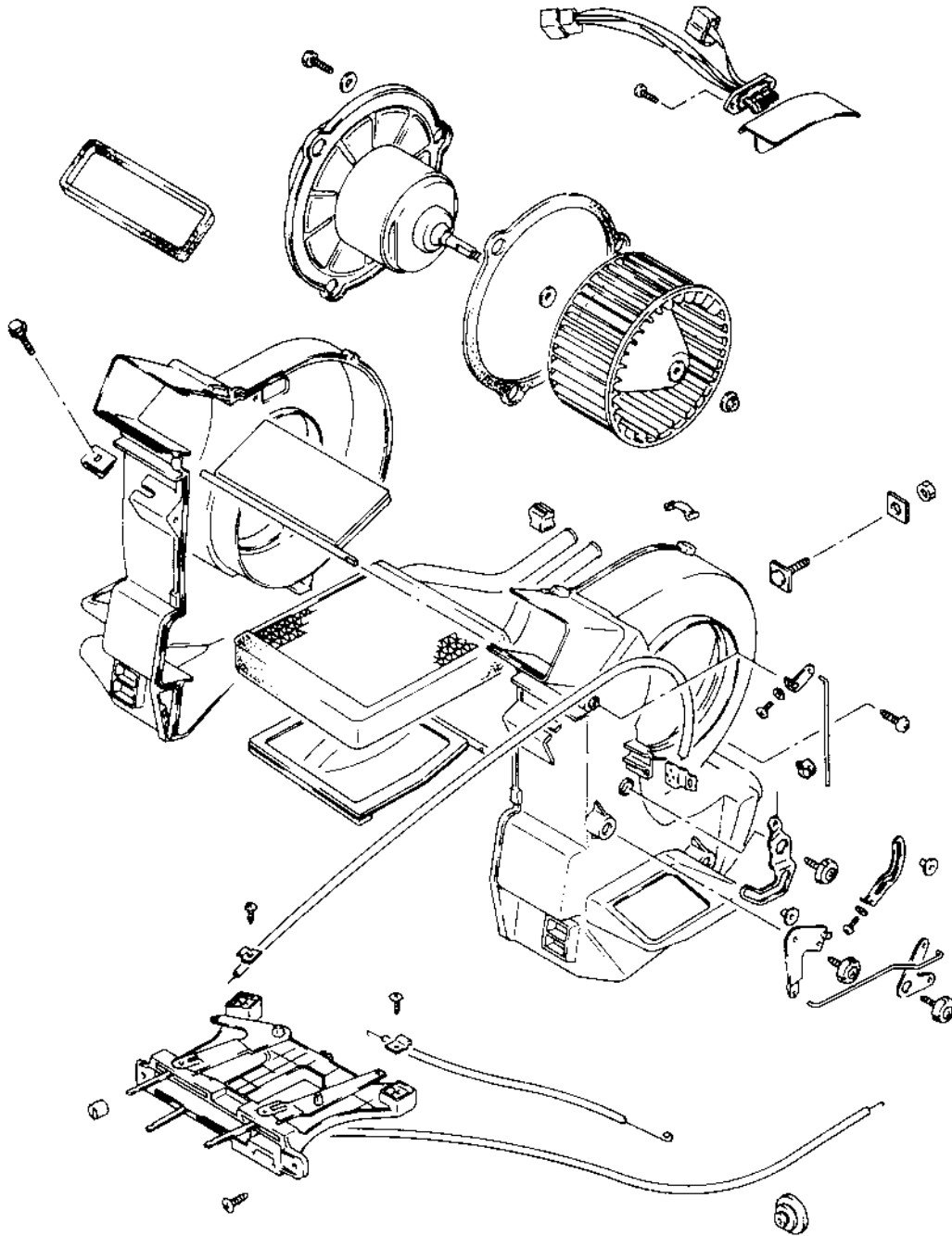


Fig. 7-1

## 7-2. ELECTRICAL CIRCUIT

The circuit diagram (Fig. 7-2) shows how the blower motor is controlled. Turn the main switch to "ON", turn (slide) the blower switch lever on one step, and voltage is applied across the blower motor. The current is small because of the resistor provided in the circuit (indicated as "blower motor resistance" in the diagram).

Under this condition, the blower runs slowly. By turning (sliding) the blower switch lever fully, the full battery voltage is applied across the blower motor, a large current flows and the blower motor runs at full speed.

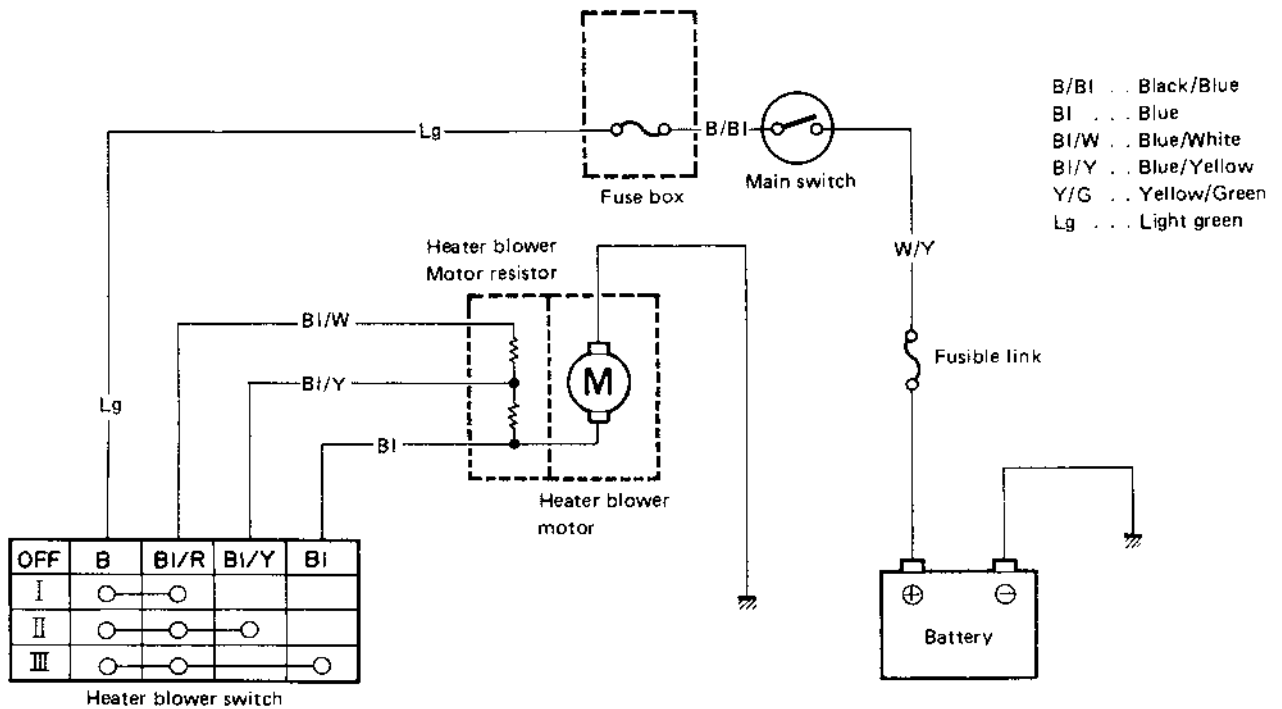


Fig. 7-2

### 7-3. HEATER SERVICES

#### Blower resistor

This resistor is on heater case. Check it for signs of cracking or breakage and replace as necessary. If blower motor will not run or when resistor is replaced, check continuity between Blue/White and Blue/Black terminals using a circuit tester.

Blower resistor specification	Several ohms
-------------------------------	--------------

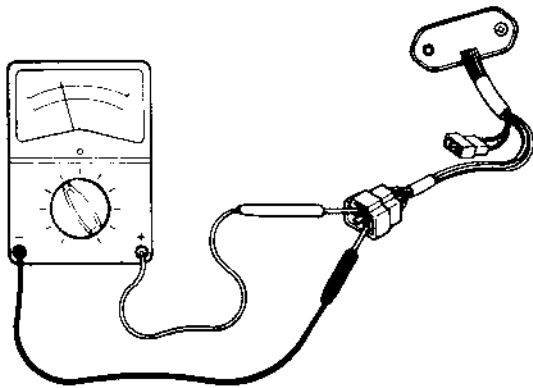


Fig. 7-3

#### Blower switch

Using a circuit tester, check this switch for circuit continuity:

III	○			○
II	○	—	○	
I	○	○		
OFF				
	Black	Blue/red	Blue/Yellow	Blue

#### Heater hoses

Check heater hoses for the connection condition, breakage, cracks and other damage and replace if necessary.

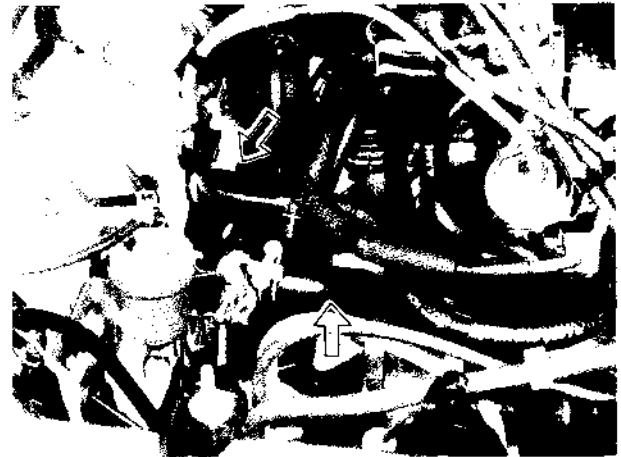


Fig. 7-4

## 7-4. REMOVAL AND INSTALLATION

### Removal

[Heater and blower motor]

1. Disconnect battery negative cable.
2. Drain cooling system.

#### IMPORTANT:

To help avoid the danger of being burned, do not remove the drain plug and the radiator cap while the engine and radiator are still hot. Scalding fluid and steam can be blown out under pressure if the plug and cap are taken off too soon.

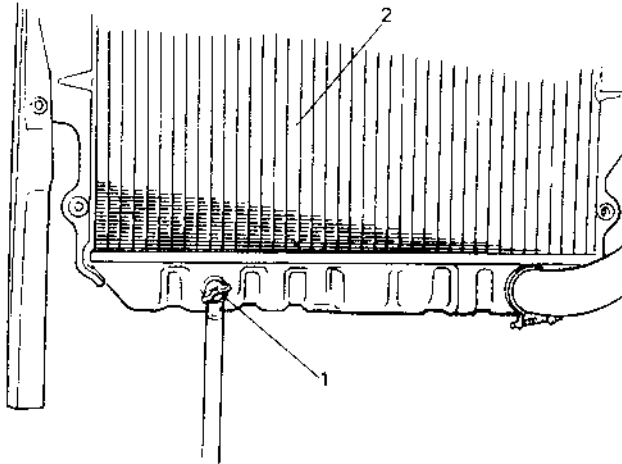


Fig. 7-5 1. Drain plug 2. Radiator

3. Disconnect heater inlet and outlet hoses from heater unit pipes.
4. Remove instrument panel ass'y with speedometer ass'y as follows.
  - 1) Take off horn pad and remove steering wheel using special tool (A).

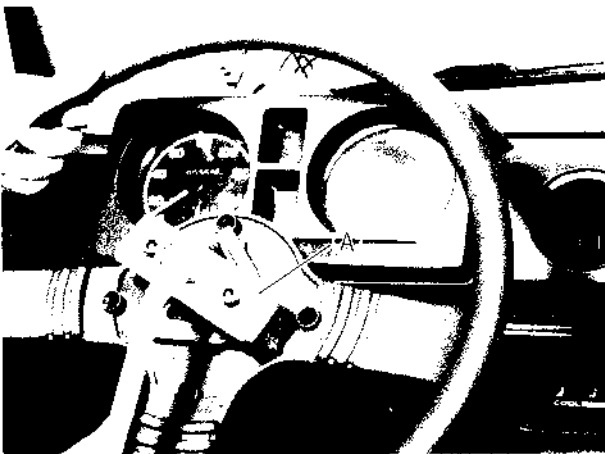


Fig. 7-6 (A) Special tool (Steering wheel remover 09944-38210)

- 2) If equipped with radio and cigarette lighter, disconnect radio and cigarette lighter lead wires, and pull out radio case with radio and cigarette lighter after loosening case stay screw, and remove radio case bracket.
- 3) Pull out ashtray and loosen ashtray plate screws.
- 4) Disconnect front food opening cable from lock ass'y.
- 5) Loosen panel box stay screw and hood opening cable lock nut on back side of panel box cover.
- 6) Disconnect lead wires to control lever at the coupler and heater control cables.
- 7) Pull out lever knobs and plate, and loosen lever case screws.
- 8) Remove defroster and side ventilator hoses.
- 9) Disconnect lead wires to speedometer and switches installed instrument panel at the couplers.
- 10) Disconnect speedometer cable from speedometer.
- 11) Release wire harness clamps installed to instrument panel.
- 12) Loosen screws securing instrument panel.
- 13) Remove instrument panel.

#### NOTICE:

- Before removing, recheck to ascertain all hoses, wire harness, cables and screws are disconnected from instrument panel.
  - When removing heater lever case which is fitted in steering column holder, be very careful not to damage it.
5. Remove steering column holder after loosening front door open stopper screws.



Fig. 7-7

- Disconnect heater blower motor and resistor lead wires at the coupler.
- Loosen heater case securing nut on the engine room side.



Fig. 7-8

- Remove heater ass'y.

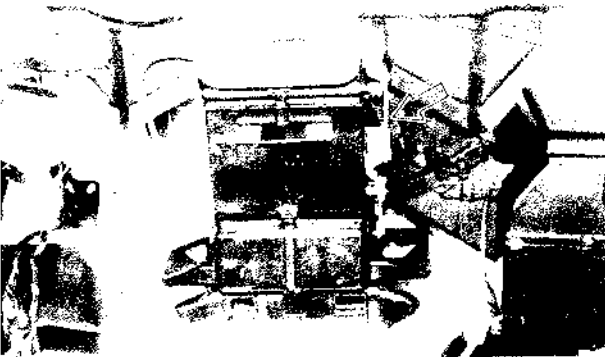


Fig. 7-9

- Remove heater blower motor.

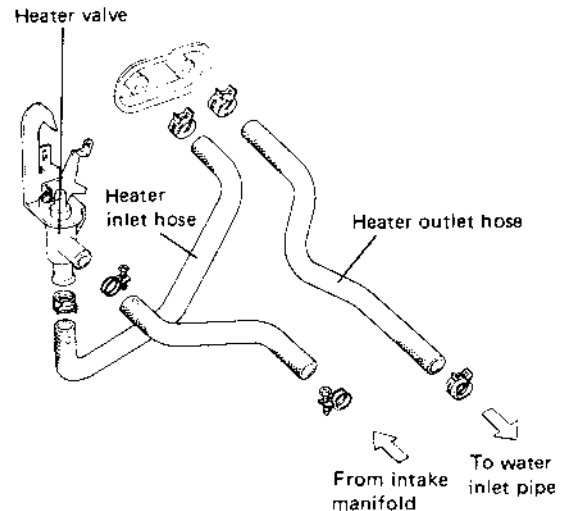
### Installation

Reverse the removal procedure for installation, exercising care to the following.

- Make definitely sure to insert holder plate between holder and body.
- When installing parts, be careful to prevent wire harness from being caught between parts.
- Clamp wire harness securely and make sure that it does not contact sharp edge of any part.

- When connecting heater hoses, route them correctly making sure they are free from twist.

[For right hand steering vehicle]



[For left hand steering vehicle]

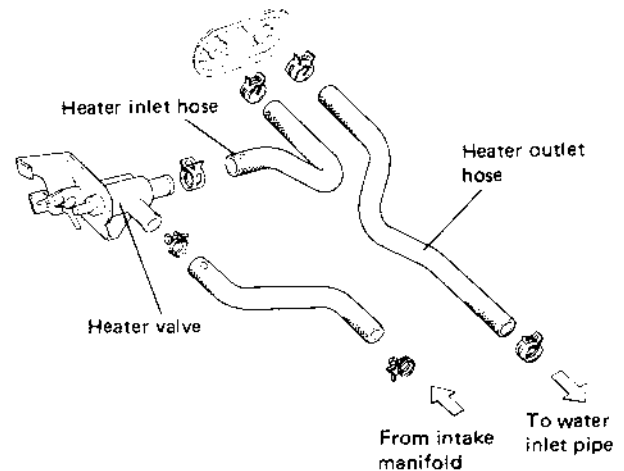


Fig. 7-10

- Refill the proper coolant. Refer to section 6.



**NOTICE:**

Upon completion of all jobs, perform following checks.

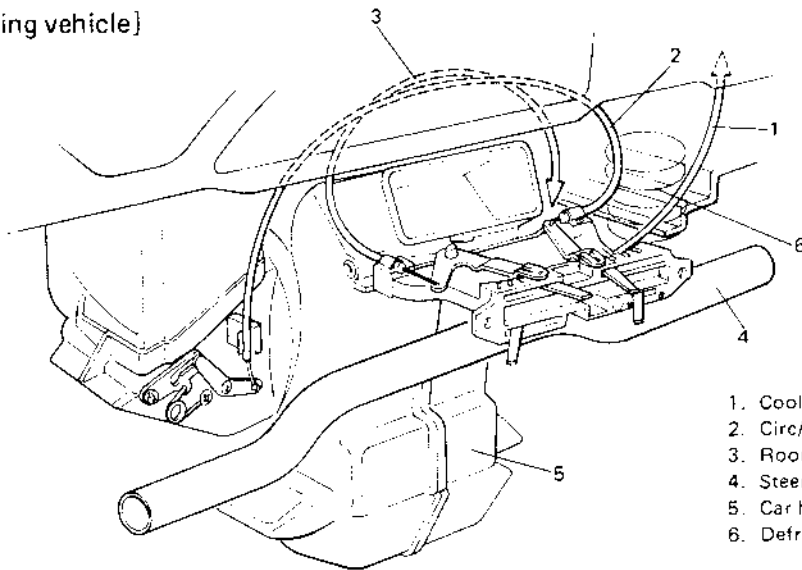
- Check to ensure that every joint of each heater hose and pipe is free from leakage of cooling water.
- Check to ensure that each control lever operates smoothly and that car heater operates correctly to each control lever position.  
If found faulty, adjust by changing control cable clamp position.
- Check to ensure that each wire harnesses are securely clamped.



Fig. 7-11

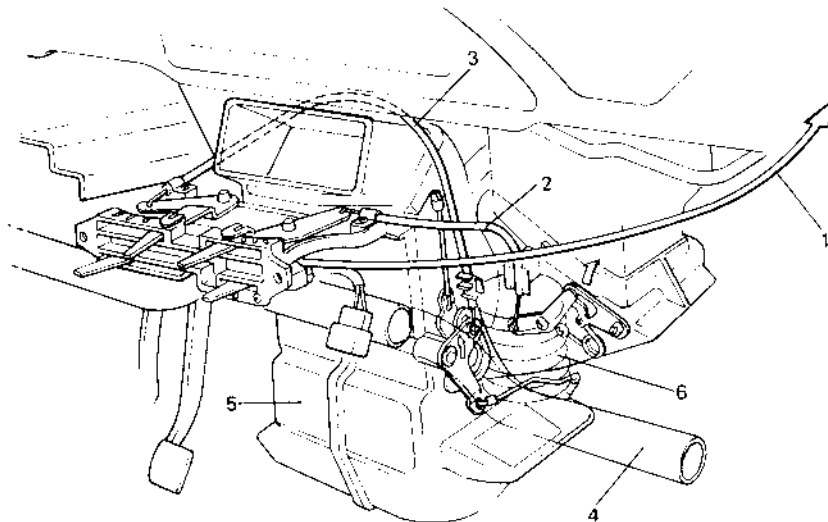
**Heater & Ventilator Control Cable Routing**

[For right hand steering vehicle]



1. Cool/hot cable
2. Circ/fresh cable
3. Room/def. cable
4. Steering column holder
5. Car heater
6. Defroster hose

[For left hand steering vehicle]





**SECTION 8**  
**IGNITION SYSTEM**

**CONTENTS**

<b>8-1. GENERAL DESCRIPTION .....</b>	<b>8-2</b>
DISTRIBUTOR .....	8-3
IGNITION COIL .....	8-4
SPARK PLUG .....	8-4
<b>8-2. MAINTENANCE SERVICE .....</b>	<b>8-5</b>
HIGH TENSION CORD .....	8-5
SPARK PLUG .....	8-5
IGNITION COIL .....	8-5
DISTRIBUTOR .....	8-5
IGNITION TIMING .....	8-9
DISTRIBUTOR DRIVE GEAR .....	8-10
<b>8-3. IMPORTANT REMINDERS FOR INSTALLATION .....</b>	<b>8-11</b>
DISTRIBUTOR .....	8-11

## 8-1. GENERAL DESCRIPTION

The ignition system is of contact-pointless type (full-transistorized type).

The principal components of the ignition system are spark plugs, ignition coil, and distributor. The distributor has a rotor, an ignitor, a signal generator, a vacuum advancer and a centrifugal advancer.

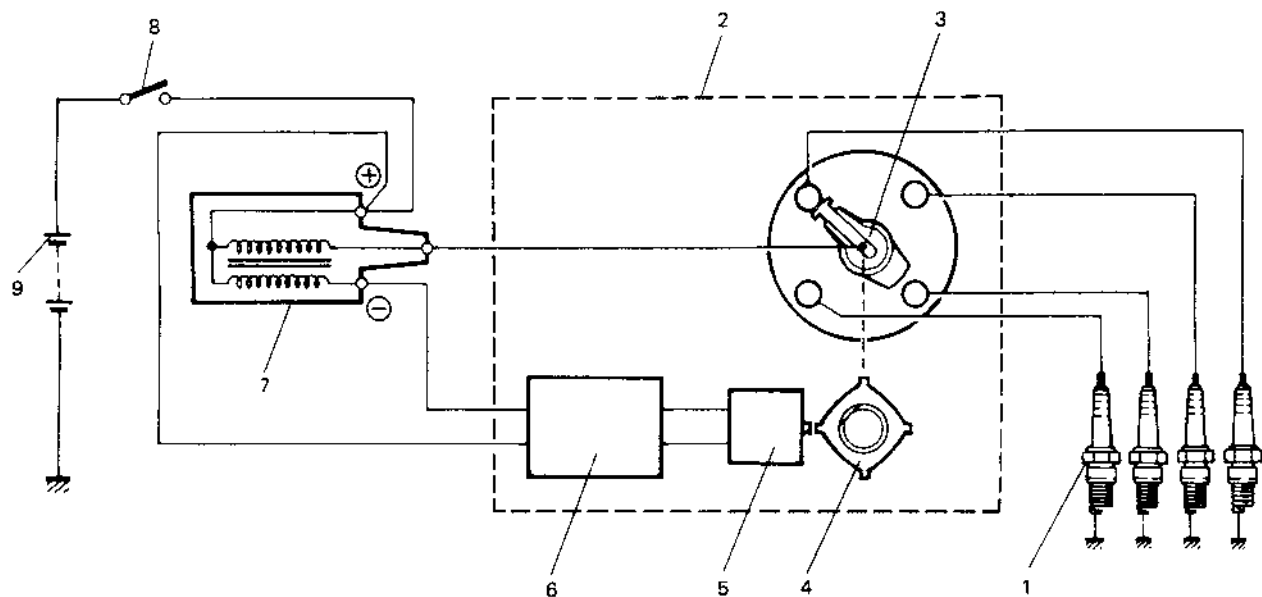
The signal generator is to generate the ignition signal and consists of a signal rotor, a magnet and a pickup coil. The signal rotor is attached to the distributor shaft, and the magnet and the pickup coil are attached to the generator base plate.

When the distributor shaft rotates, the magnetic flux passing through the pickup coil varies due to the change in air gap between the pickup coil and the signal rotor. As a result, the alternating current voltage is induced in the pickup coil. The voltage induced turns on and off the ignitor which switches off the ignition coil primary current. Thus, the high voltage is induced in the secondary winding of ignition coil and ignition sparks are generated at the spark plugs.

The distributor is a sort of rotary switch, whose rotor connects the four plugs, one at a time, to secondary winding of the ignition coil through the wires called "high-tension" cords. Note that there are one high-tension cord, from secondary winding to the center of the distributor cap, and four more high-tension cords between the spark plugs and the four terminals on the cap.

### NOTICE:

Whereabouts of terminal connections are clearly indicated in the diagram below. When inspecting the electrical wiring, refer to this diagram and check to be sure that each connection is tight. Examine the cords for torn insulation and for evidence of grounding.



1. Spark plug
2. Distributor
3. Distributor rotor
4. Signal rotor
5. Generator
6. Ignitor
7. Ignition coil
8. Ignition switch
9. Battery

Fig. 8-1

## Distributor

1. Vacuum controller
2. Distributor cap
3. Seal
4. Distributor housing
5. Distributor driven gear
6. Pin
7. O-ring
8. Rotor
9. Signal generator dust cover
10. Ignitor dust cover
11. Signal generator
12. Ignitor
13. Generator base plate
14. Signal rotor

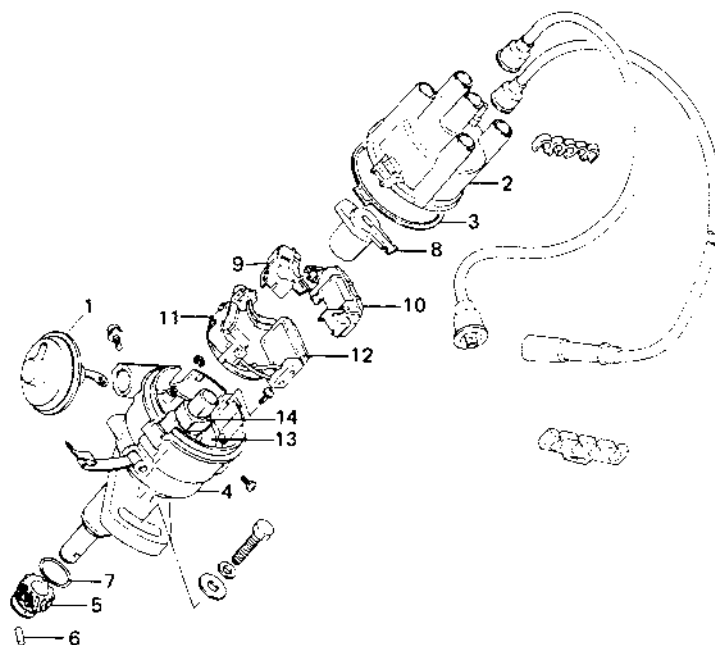


Fig. 8-2

### [Timing advancer]

The distributor shaft, from its driven-gear end to the rotor-carrying end, is not a single solid piece; actually this shaft is in two pieces connected together through the timing advancer. The advancer is essentially a flyweight mechanism. Timing advancing action is accomplished by twisting the top shaft piece relative to the bottom one in the direction of shaft rotation. The single rotor is mounted on the top piece. The twisting movement is produced by the speed-dependent radial (or spreading) movements of the two flyweights.

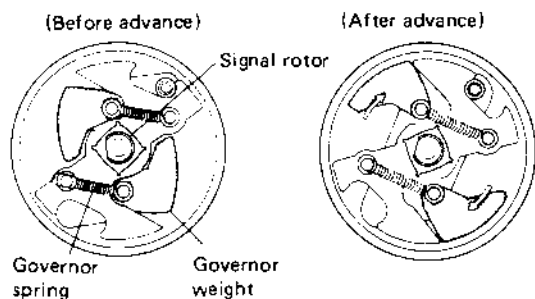


Fig. 8-3

### [Vacuum advancer]

In this vacuum-advance mechanism, when the vacuum in the carburetor gets high, the pressure acting on the diaphragm overcomes the spring force in it and the controller rod attached to the diaphragm is pulled. And the rod so pulled turns the generator base plate counter to the direction of the distributor shaft rotation (counterclockwise) to advance (quicken) the ignition.

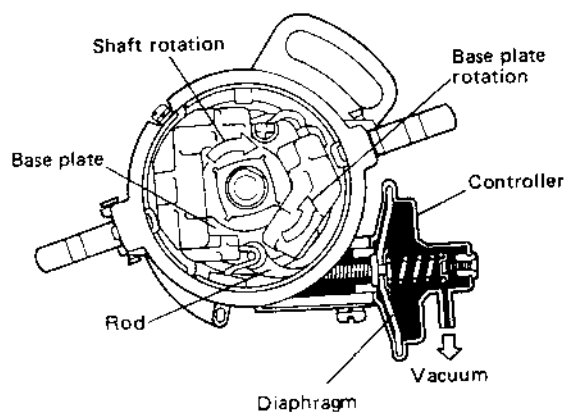


Fig. 8-4

### Ignition Coil

The ignition coil is a sort of miniature transformer and, as such, has an iron core around which two coils are wound – primary and secondary windings mentioned above. The two are so close to each other that a sudden change in the magnetic flux produced by “primary current” flowing in primary winding (in a less number of coil turns) induces a very large electromotive force (voltage) in secondary winding (in a greater number of coil turns). These live parts are housed in a tight, insulator case topped by the cap. Note that the cap has three terminals: one high-tension terminal and two low-tension terminals.

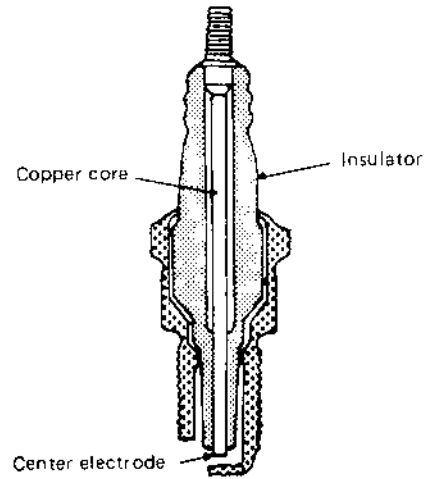


Fig. 8-6

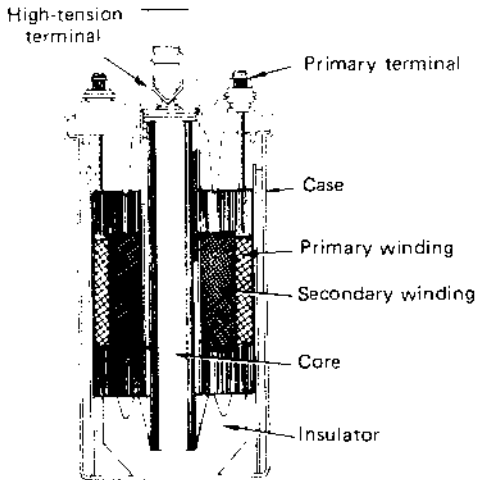


Fig. 8-5

### Spark Plugs

Each new machine shipped from the factory is fitted with standard plugs.

	Standard type	Cold type
NGK	BPR-5ES	BPR-6ES
Nippon Denso	W16EXR-U	W20EXR-U

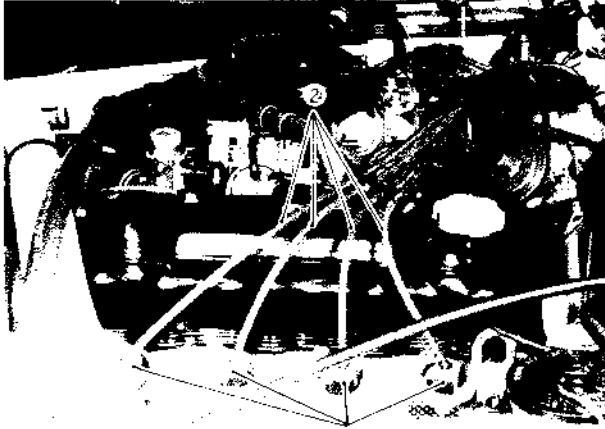
## 8-2. MAINTENANCE SERVICE

### High Tension Cords

Check cord terminals for corrosion, breaks and distortion, and cords for crack or deterioration. Replace cord as necessary.

#### NOTICE:

**DO NOT** bend or pull high tension cords to avoid inside damage. Grip rubber boot when removing or installing cords.



1. Rubber boot
2. High tension cord

Fig. 8-7

### Spark Plugs

Check following:

- Electrode wear
- Carbon deposits
- Insulator damage.

If any fault is found, replace plugs.

Check gap, and make sure that gap is within specification. If gap is out of specification, adjust it by bending ground (side) electrode.

Plug gap "A"	0.7 – 0.8 mm (0.027 – 0.031 in.)
--------------	-------------------------------------

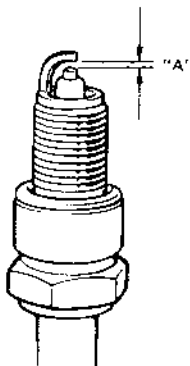


Fig. 8-8

### Ignition Coil

Disconnect negative cable at battery. Disconnect lead wires and high tension cord from ignition coil. Remove ignition coil, and check it as follows.

Measure primary coil resistance.

Using ohmmeter, measure resistance between positive  $\oplus$  and negative  $\ominus$  terminals.

Primary coil resistance	1.35 – 1.65 $\Omega$
-------------------------	----------------------

Measure secondary coil resistance.

Using ohmmeter, measure resistance between positive  $\oplus$  terminal and high tension terminal.

Secondary coil resistance	11.0 – 14.5 k $\Omega$
---------------------------	------------------------

#### NOTICE:

Take readings when coil is about 20° C (68° F).



Fig. 8-9

Reverse removal procedure for installation.

When reinstalling, make sure that each connection is tight.

### Distributor

[Distributor cap]

Leakage of high-tension energy for ignition shows up as misfiring in the engine. It occurs at any part of the high-tension line where insulation has failed or in a dirty distributor cap, that is, an internally dirty cap.

A wider spark gap in the plug, a condition often found in poorly cared spark plugs, promotes a tendency of high-tension energy to find a short-cut to ground.

Cleanliness is very important for the distributor cap. With a clean dry cloth, wipe off dust or grime, if any, and inspect for any damaged (scarred, scratched or cracked) part or any part evidencing high-tension leakage inside the cap. Be sure to replace such parts.

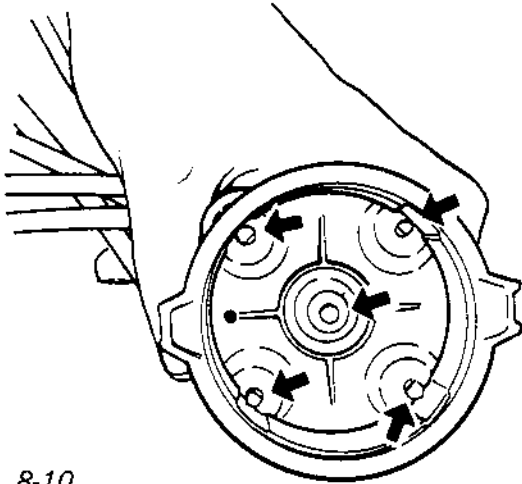


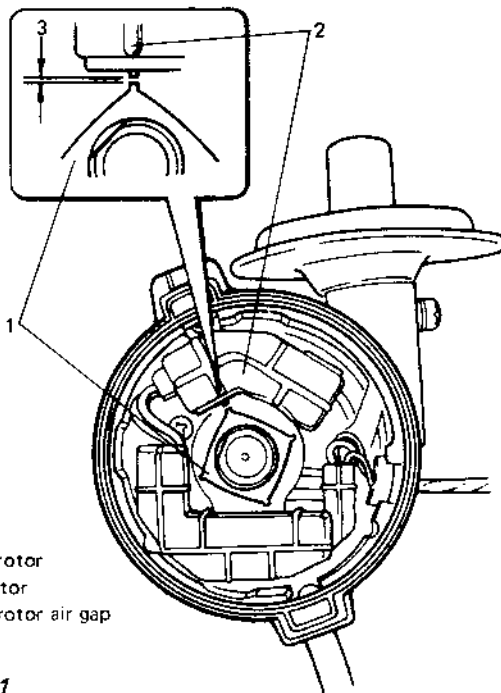
Fig. 8-10

[Signal rotor air gap]

Signal rotor air gap	0.2 – 0.4 mm (0.008 – 0.016 in)
----------------------	------------------------------------

Check air gap and adjust it as necessary.

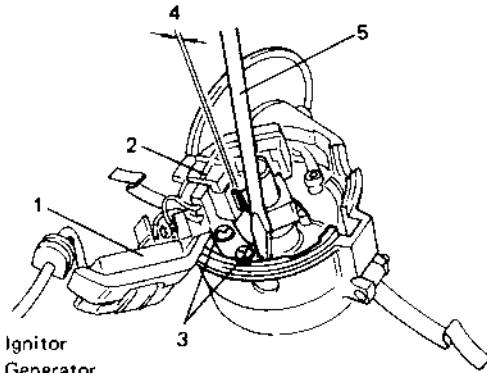
1. Remove distributor cap and rotor.
2. Using thickness gauge, measure air gap between signal rotor tooth and generator.



1. Signal rotor
2. Generator
3. Signal rotor air gap

Fig. 8-11

3. If air gap is out of specification, adjust it. Remove distributor and then ignitor. Loosen 2 screws securing generator. Using blade (—) screwdriver, move generator and adjust air gap to specification.



1. Ignitor
2. Generator
3. Generator screw
4. Signal rotor air gap
5. Blade screwdriver

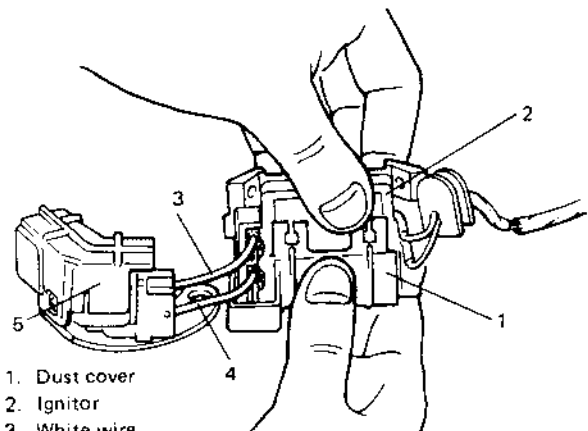
Fig. 8-12

After adjustment, tighten 2 screws and recheck air gap. Install ignitor, rotor and distributor cap.

Install distributor referring to p. 8-11.

[Generator]

1. Disconnect negative cable at battery. Remove distributor, and then ignitor and generator.
2. Remove dust cover from ignitor.
3. Disconnect red and white wires from ignitor.



1. Dust cover
2. Ignitor
3. White wire
4. Red wire
5. Generator

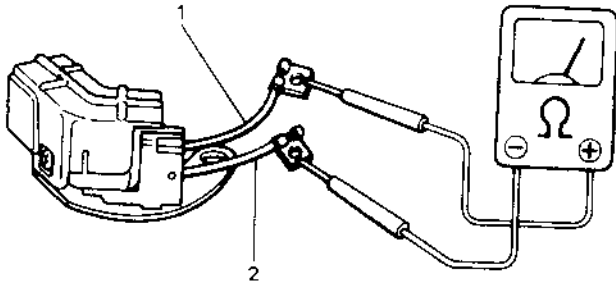
Fig. 8-13

4. Connect ohmmeter to red and white wires, and measure generator resistance. Generator resistance should be within 130 – 190 ohms. If resistance is not within specification, replace the generator.



Generator (Pickup coil) resistance

130 – 190 ohms



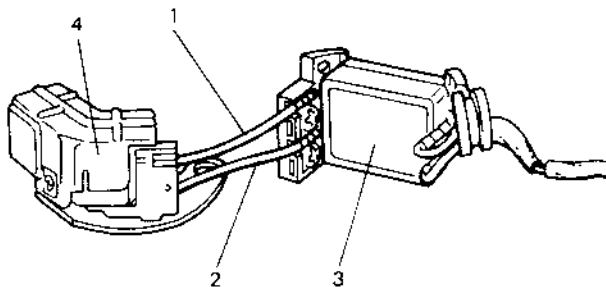
1. White wire
2. Red wire

Fig. 8-14

5. After checking, connect red and white wires to ignitor as shown in Figure 8-15, and then install dust cover.

**NOTICE:**

**NEVER** connect red and white wires reversely. Reverse connection may cause damage to generator and ignitor.



1. White wire
2. Red wire
3. Ignitor
4. Generator

Fig. 8-15

6. After generator has been assembled on distributor, make sure to adjust air gap and install ignitor.
7. Install distributor referring to page 8-11.

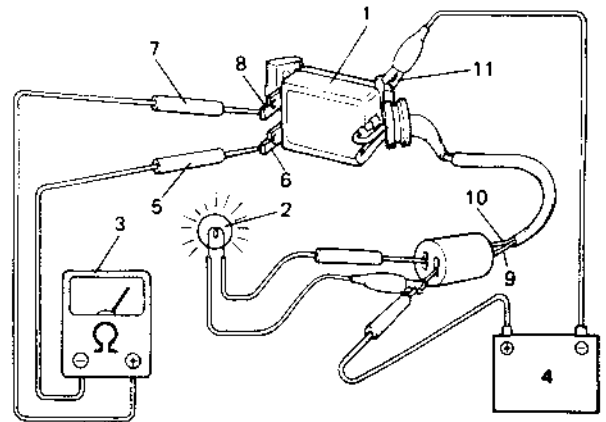
[Ignitor]

1. Disconnect negative cable at battery. Remove distributor, and then ignitor and generator.
2. Remove dust cover from ignitor.
3. Disconnect red and white wires from ignitor.
4. Connect an ohmmeter, a bulb and 12 voltage battery to ignitor as shown in Figure 8-16.

Set ohmmeter at 1 ohm to 10 ohm range. Then bring ohmmeter negative  $\ominus$  prod to touch red wire terminal of ignitor, and positive  $\oplus$  prod to touch white wire terminal. If bulb is illuminated, it indicates that ignitor is satisfactory. If not, replace ignitor.

**NOTICE:**

- Never connect battery positive and negative wires reversely. Reverse connection may cause damage to ignitor.
- Under no circumstances should ohmmeter be connected reversely.
- Be sure to perform this ohmmeter check within a short time (two to three seconds).



- |                  |                        |                     |
|------------------|------------------------|---------------------|
| 1. Ignitor       | 5. Negative prod       | 9. Black/White wire |
| 2. Bulb          | 6. Red wire terminal   | 10. Brown wire      |
| 3. Ohmmeter      | 7. Positive prod       | 11. Earth           |
| 4. Battery (12V) | 8. White wire terminal |                     |

Fig. 8-16

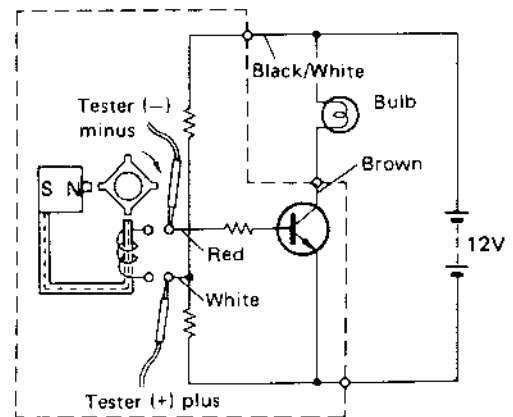


Fig. 8-17

5. After checking, connect red and white wires of generator to ignitor and install dust cover on ignitor.  
Refer to Fig. 8-15 for proper connection of red and white wires.
6. After the generator and ignitor have been assembled on the distributor, make sure to adjust the air gap.
7. Install distributor referring to page 8-11.

[Distributor driven gear]

Inspect gear teeth for wear, and see if the backlash is normal or not. Excessive backlash can be told by turning the shaft back and forth, with its driven gear in mesh with driving gear. Maladjusted ignition timing is often due to excessive tooth wear in this gearing and, in such a case, can be corrected by replacing driven gear.



Fig. 8-18

To replace driven gear, grind off both caulked ends of driven gear set pin with grinder and drive it off. After fitting new gear, make sure to use a new pin and caulk its both ends.

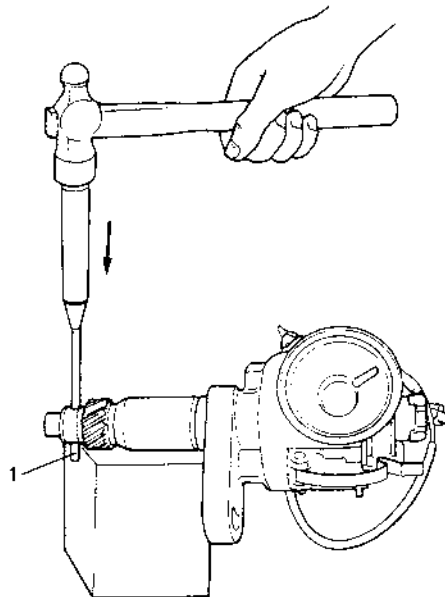


Fig. 8-19 1. Driven gear set pin

## Ignition Timing

Ignition timing	10° BTDC at 800 ± 50 r/min
Ignition order	1 - 3 - 4 - 2

When checking and adjusting ignition timing, be sure to use timing light (09900-27301 or 09900-27311).

### NOTICE:

Prior to check and adjustment of ignition timing, make sure that head lights, heater fan, rear defogger (if equipped), and air conditioner (if equipped) are "OFF". If any one of these systems is "ON", idle up system operates and engine idle speed will be out of the specification.

### [Checking]

1. Remove rubber plug from timing check window on the transmission case.
2. Start engine and warm it up to normal operating temperature.
3. After warming up, check to be sure that idle speed is within specification. If idle speed is out of specification, adjust it by turning idle speed adjusting screw of carburetor.
4. Connect timing light to high tension cord of No. 1 cylinder.
5. With engine running at specified idle speed, direct the timing light to timing check window. If 10° BTDC timing mark ① on flywheel appears aligned to timing match mark ②, ignition is properly timed.

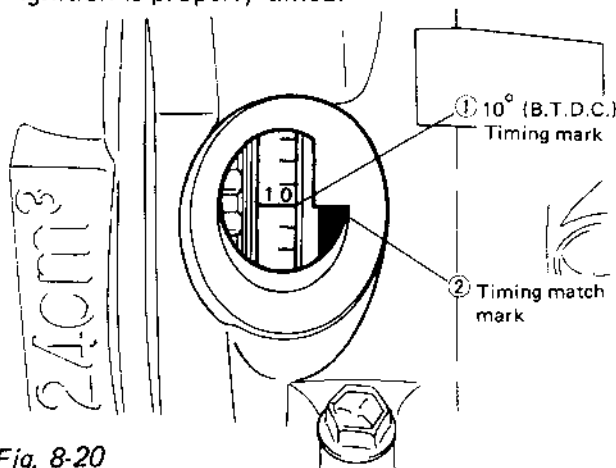


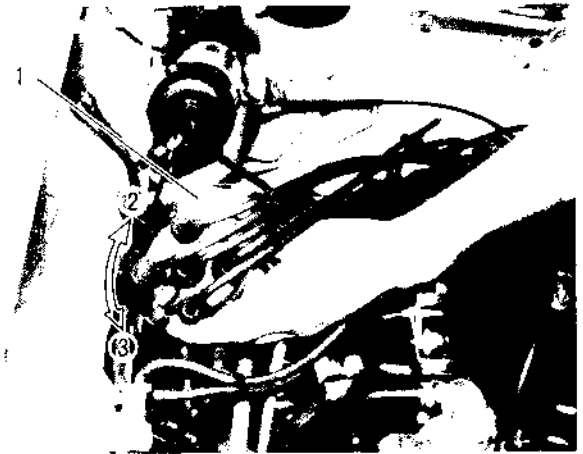
Fig. 8-20

### [Adjusting]

If ignition timing is out of specification, adjust it.

Loosen distributor flange bolt and turn distributor housing in place to advance or retard timing.

Turning housing counterclockwise advances timing, and vice versa. After adjustment, tighten flange bolt and recheck timing.



1. Distributor flange bolt
2. Timing is retarded
3. Timing is advanced

Fig. 8-21

Be sure to re-install check window rubber plug after making above check and adjustment.

### WARNING:

When engine is warmed up, exhaust manifold cover and other parts are hot as well. Be careful not to touch them when removing and reinstalling rubber plug.

### [Checking centrifugal advancer]

After removing distributor cap, turn rotor clockwise by finger and release it. Check that rotor returns smoothly counterclockwise by spring force.

If defective, replace distributor.

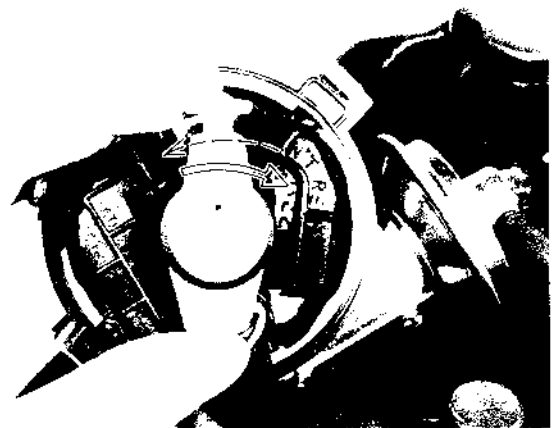
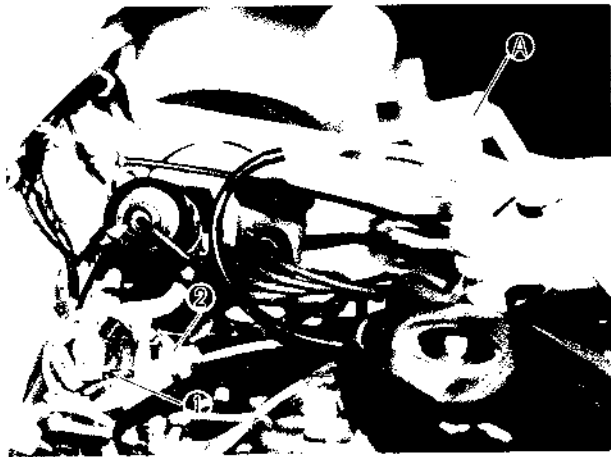


Fig. 8-22

[Checking vacuum advancer]

Remove distributor cap.

Disconnect vacuum hose from vacuum hose 3 way joint, and connect vacuum pump gauge (09917-47910) to its hose. Apply vacuum (about 400 mmHg). And then with pump stopped, check to ensure that vacuum pump gauge indicator remains at the same level, and release it. Check that generator base plate with generator moves smoothly. If plate does not move smoothly, replace defective parts.



- A Vacuum pump gauge (09917-47910)  
1. Generator base plate  
2. Vacuum controller

Fig. 8-23

### Distributor Drive Gear

#### NOTICE:

When removing distributor gear case from cylinder head, engine oil in cylinder head may come out. So place waste or receiver under gear case when removing.

Inspect drive gear for wear.

Worn gear is likely to disturb ignition timing and therefore must be replaced.

Replacing worn-down drive gear is not enough. Inspect driven gear (a part of the distributor assembly), too, and replace it if badly worn down.



1. Distributor drive gear  
2. Camshaft  
3. Cylinder head

Fig. 8-24

[Important reminders for removal and installation]

- Before removing drive gear from camshaft, scribe a match mark on this shaft to root center line of drive gear as shown in Fig. 8-25 and, when mounting replacement drive gear, refer to this mark.
- When pressing replacement drive gear onto camshaft, be sure to position gear angularly as shown in Fig. 8-25. (align mark on camshaft scribed in removal with root center of drive gear)

#### NOTICE:

There is no need to discriminate between two end faces of drive gear.

Distributor side view

1. Drive gear  
2. Camshaft  
3. Center line of  $\phi 5$  mm hole  
4. Center line of root  
5.  $\phi 5$  mm hole (Provided on pulley side of camshaft)  
6. Scribed match mark  
7.  $5^\circ$

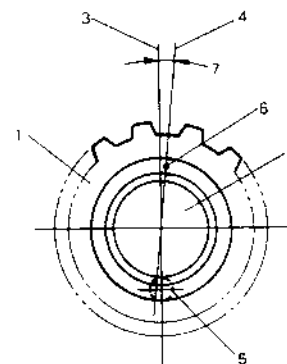


Fig. 8-25

- About 30 cc (1.01/1.05 US/Imp oz) of engine oil must be fed into distributor gear case after servicing this case, that is, removing and putting it back. Be sure to add this much oil before starting engine for the first time after servicing.

### 8-3. IMPORTANT REMINDERS FOR INSTALLATION

#### Distributor

When re-installing distributor, be sure to insert it into distributor gear case in the following sequence:

1. Turn over crankshaft in normal direction (clockwise as viewed from crankshaft pulley side) until specified timing mark ① on flywheel aligns with timing match mark ②.

#### CAUTION:

After aligning two marks, remove cylinder head cover to visually confirm that rocker arms are not riding on camshaft cams at No. 1 cylinder. If arms are found to be riding on cams, turn over crankshaft 360° to align two marks anew.

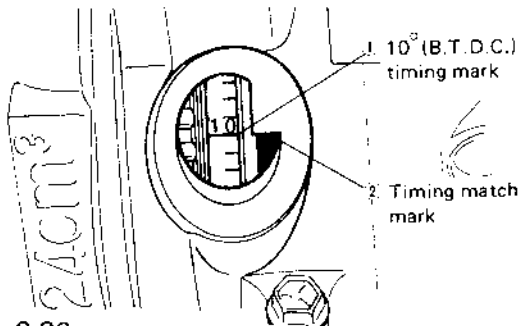


Fig. 8-26

2. Remove distributor cap, and turn rotor to make center of rotor align with cap clamp center on distributor housing as shown in figure.

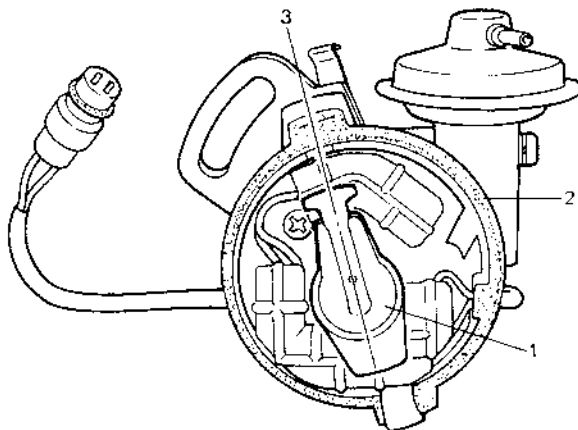


Fig. 8-27

1. Rotor
2. Housing
3. Center of rotor and clamp

3. Insert distributor into gear case in such a way that center of distributor flange will coincide with the distributor mounting screw hole provided in distributor gear case. When

distributor is inserted properly, position of distributor rotor becomes as shown in figure. Secure distributor in place tentatively by making mounting screw finger-tight.



Fig. 8-28

1. Distributor flange
2. Mounting screw
3. Rotor

4. Install cap gasket and distributor cap to distributor. Hook 2 clamps securely.
5. Distribute cords as shown in figure. Securely connect cords to distributor cap terminals and spark plugs.

#### NOTICE:

Make sure to clamp high tension cords so that they do not contact other parts.



1. No. 1 cylinder
2. No. 2 cylinder
3. No. 3 cylinder
4. No. 4 cylinder

Fig. 8-29 High tension cords distribution

6. Connect vacuum hose to vacuum controller, and coupler of lead wires.
7. Connect negative cable at battery.
8. Start engine and adjust ignition timing by using timing light as previously outlined. After adjustment, tighten distributor flange bolt.



# SECTION 9

## CRANKING SYSTEM

### CONTENTS

9-1.	GENERAL DESCRIPTION .....	9-2
9-2.	SPECIFICATIONS .....	9-4
9-3.	LUBRICATION .....	9-5
9-4.	REMOVAL AND INSTALLATION .....	9-5
9-5.	DISASSEMBLY .....	9-6
9-6.	STARTING MOTOR INSPECTION .....	9-7
	COMMUTATOR .....	9-7
	FIELD COIL .....	9-8
	BRUSH .....	9-8
	BRUSH HOLDER AND SPRING .....	9-9
	DRIVE LEVER .....	9-9
	PINION .....	9-9
	ARMATURE SHAFT BUSH .....	9-9
	MAGNETIC SWITCH .....	9-10
9-7.	PERFORMANCE TEST .....	9-11
	PULL-IN TEST .....	9-11
	HOLD-IN TEST .....	9-11
	PLUNGER RETURN .....	9-11
	PERFORMANCE TEST .....	9-11
9-8.	CLUTCH SWITCH .....	9-12

## 9-1. GENERAL DESCRIPTION

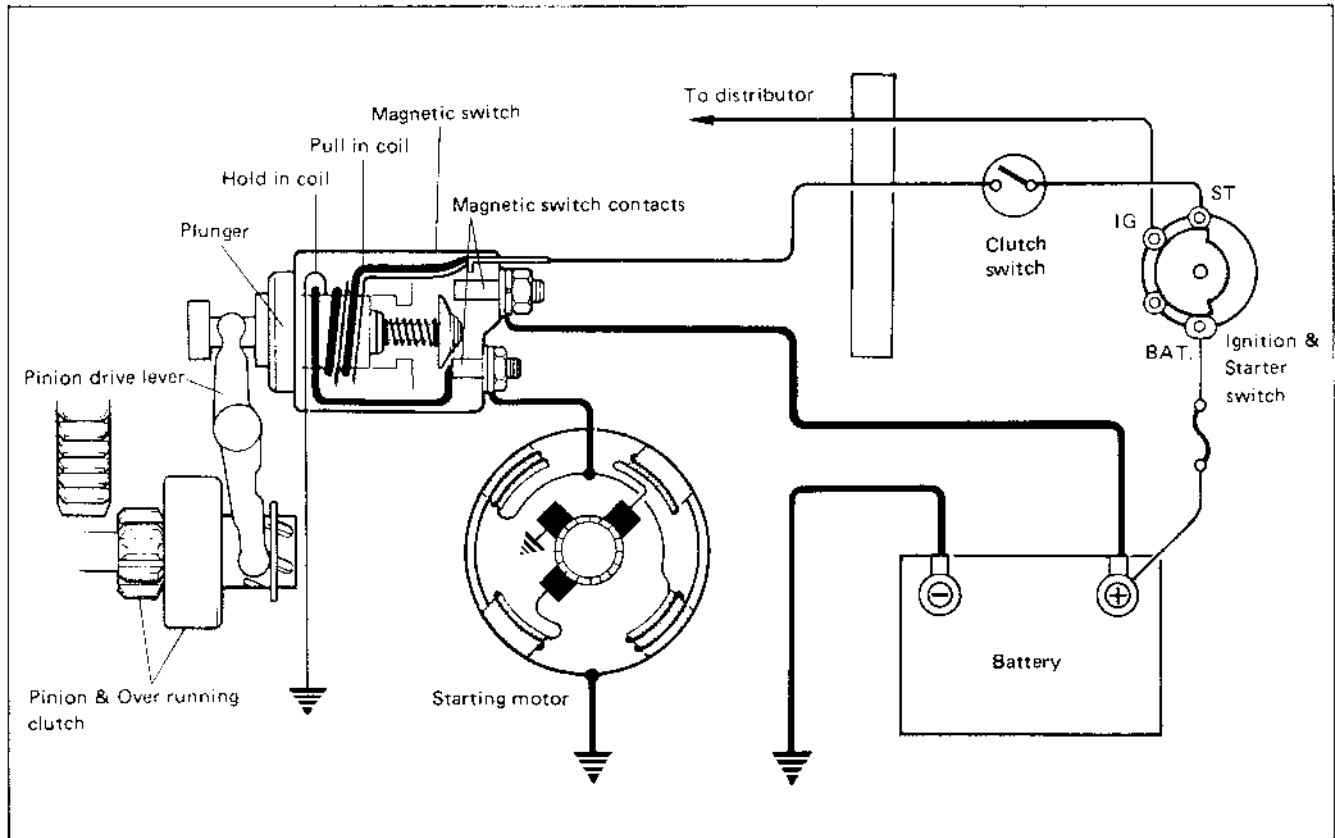


Fig. 9-1 Cranking circuit

### CRANKING CIRCUIT

The cranking circuit consists of the battery, starting motor, ignition switch, clutch switch and related electrical wiring. These components are connected electrically as shown in Fig. 9-1. Only the starting motor will be covered in this portion.

### STARTING MOTOR

The starting motor consists of parts shown in Fig. 9-2 and has field coils mounted in starting motor yoke (frame).

The magnetic switch assembly and parts in the starting motor are enclosed in the housings so that they will be protected against possible dirt and water splash.

In the circuit shown in Fig. 9-1, the magnetic (motor) switch coils are magnetized when the ignition switch is closed. The resulting plunger and pinion drive lever movement causes the pinion to engage the engine flywheel gear and the magnetic switch main contacts to close, and cranking takes place. When the engine starts, the pinion overrunning clutch protects the armature from excessive speed until the switch is opened, at which time the return spring causes the pinion to disengage.



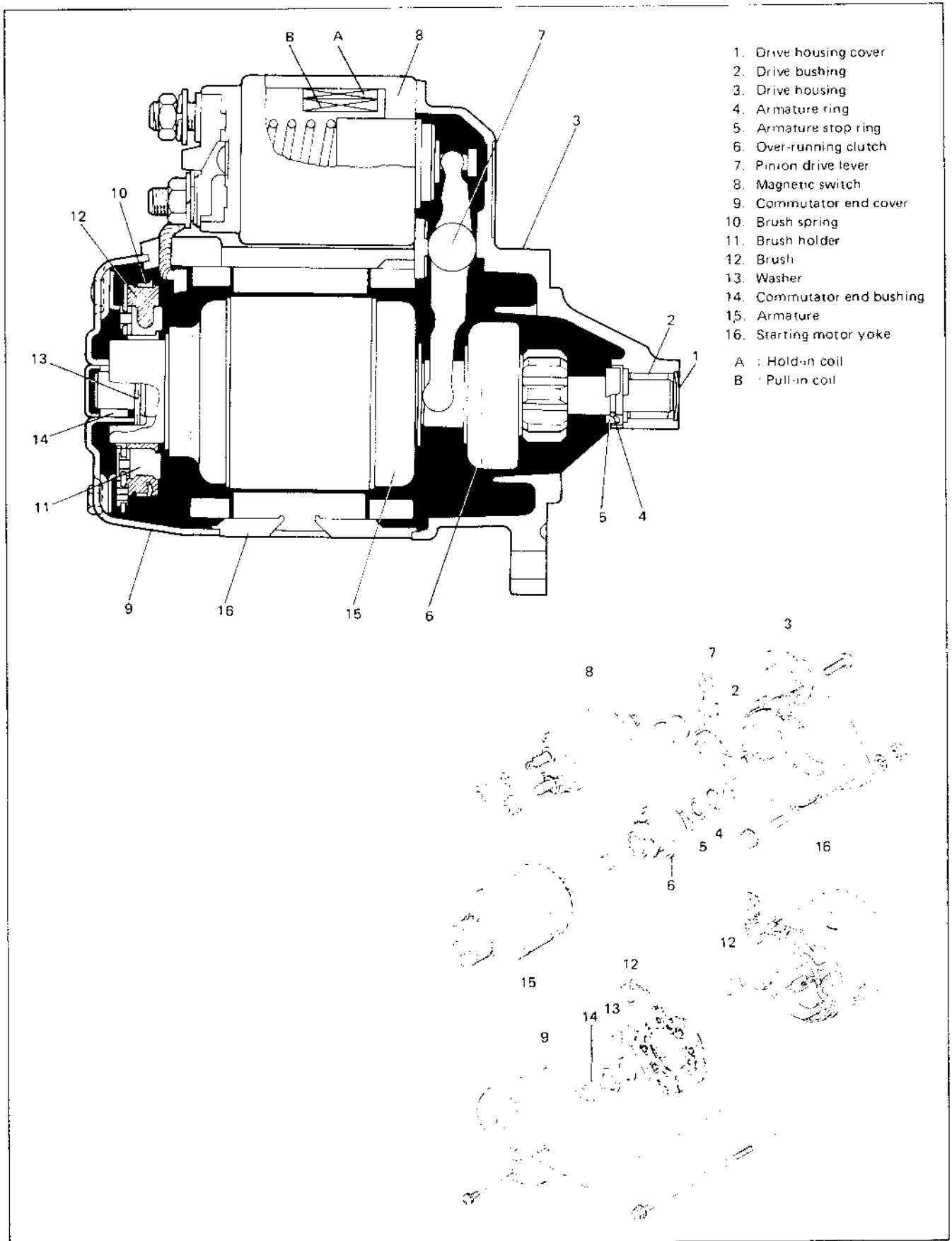


Fig. 9-2

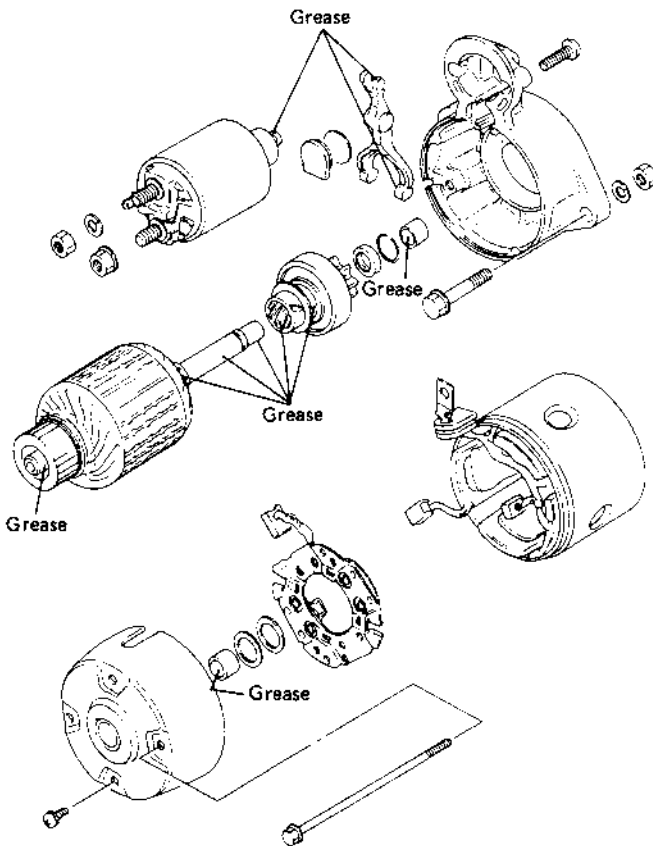
## 9-2. SPECIFICATIONS

Voltage	12 volts
Output	0.9 kW
Rating	30 seconds
Direction of rotation	Clockwise as viewed from pinion side
Brush length	17 mm (0.67 in.)
Number of pinion teeth	8
No-load characteristic	60 A maximum at 11.5 volts, 6,600 r/min minimum
Load characteristic	150 A maximum at 9 volts and 0.29 kg-m torque, 1,900 r/min minimum
Locked rotor current	500A maximum at 5 volts, 1.15 kg-m minimum
Magnetic switch operating voltage	8 volts maximum

### 9-3. LUBRICATION

The starting motor does not require lubrication except during overhaul.

When the motor is disassembled for any reason, lubricate as follows:



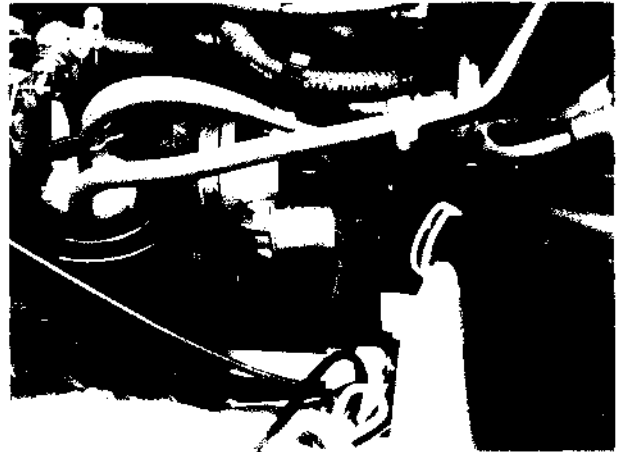
Bearing grease  
SUZUKI SUPER GREASE A  
99000-25010

*Fig. 9-3 Starting motor greasing point*

### 9-4. REMOVAL AND INSTALLATION

Use following procedure to remove starter:

- 1) Disconnect negative battery lead at battery.
- 2) Disconnect magnetic switch lead wire (BLACK/YELLOW) and battery cable from starting motor terminals.
- 3) Remove two starting motor mount bolts.
- 4) Remove starting motor.
- 5) To install, reverse the above procedure.



*Fig. 9-4 Starting motor mounting*

## 9-5. DISASSEMBLY

### NOTICE:

Before disassembling starting motor, be sure to put match marks at two locations (A and B) as shown in the figure below so that any possible mistakes can be avoided.

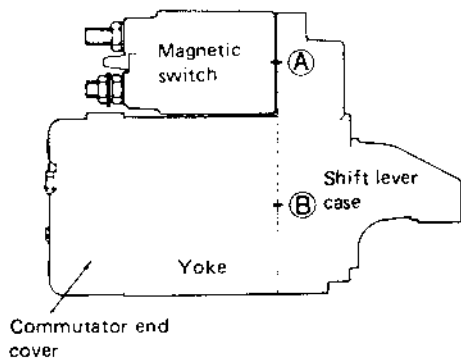


Fig. 9-5

- 1) Remove nut securing the end of field coil lead to terminal on the head of magnetic switch.

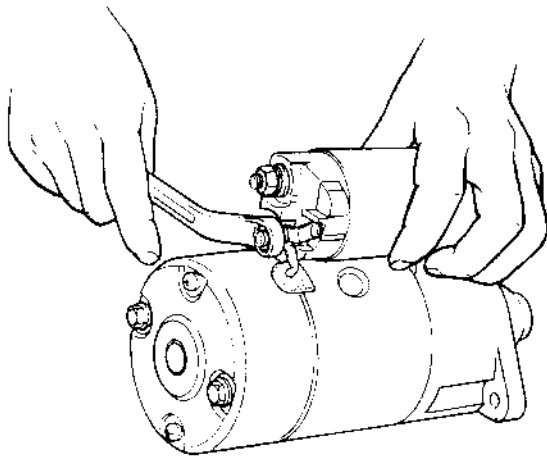


Fig. 9-6

- 2) Take off magnetic switch ① from starting motor body by removing two mounting screws.

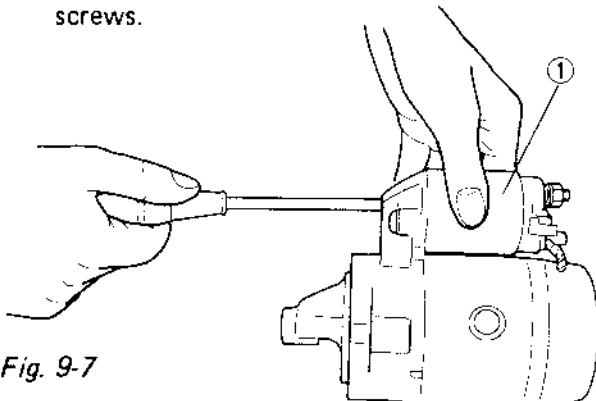


Fig. 9-7

- 3) Loosen 2 bolts and 2 screws to remove commutator end cover.
- 4) Separate drive housing and armature from yoke.

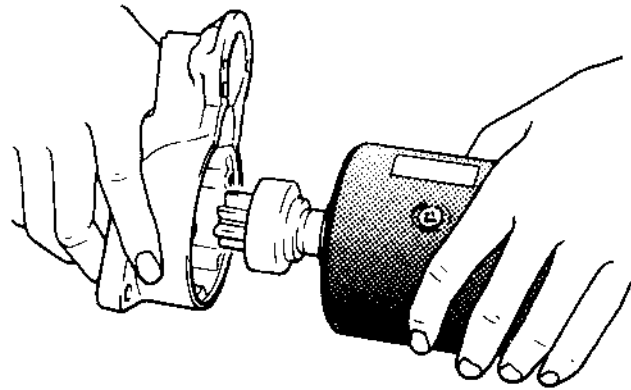


Fig. 9-8

- 5) Draw brushes out of holder.

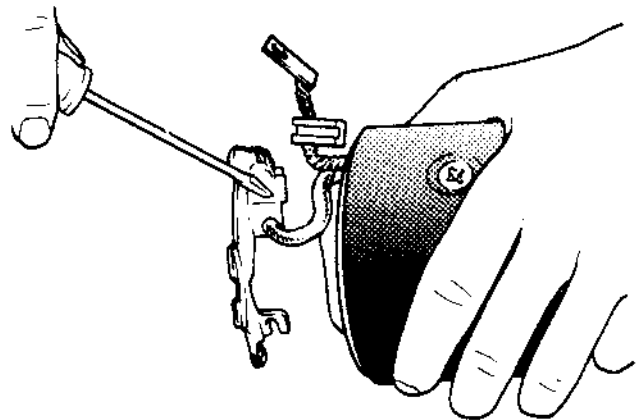


Fig. 9-9

- 6) Draw off over running clutch, as follows:
  - (1) Draw stop ring ① toward clutch side.
  - (2) Remove armature ring ② and slide off clutch.

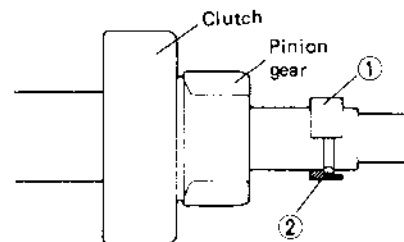


Fig. 9-10

## 9-6. STARTING MOTOR INSPECTION

### 1) Inspect Commutator

Inspect commutator for dirt or burn. Correct with sandpaper or lathe, if necessary.

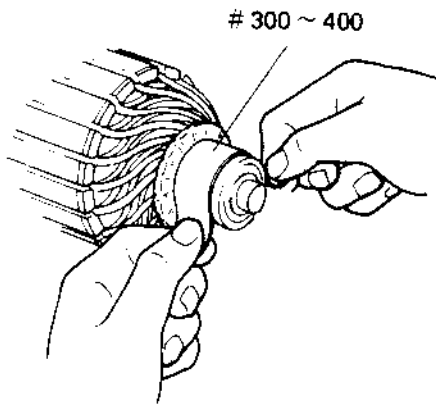


Fig. 9-11

Check commutator for uneven wear. If deflection of dial gauge pointer exceeds limit, repair or replace.

#### NOTICE:

Below specification presupposes that armature is free from bend. Bent shaft must be replaced.

	Standard	Limit
Commutator out of round	0.05 mm (0.0019 in.) or less	0.4 mm (0.015 in.)

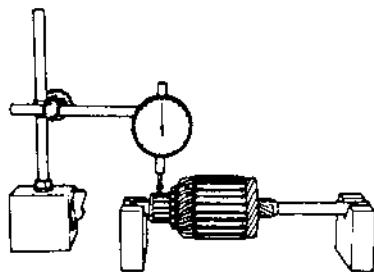


Fig. 9-12

Inspect commutator for wear. If below limit, replace armature.

	Standard	Limit
Commutator outside diameter	32 mm (1.26 in.)	31 mm (1.22 in.)

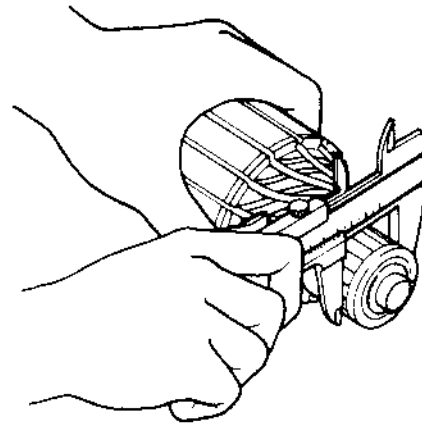


Fig. 9-13

Inspect commutator for mica depth. Correct or replace if below limit.

	Standard	Limit
Commutator mica depth	0.4 – 0.6 mm (0.015 – 0.023 in.)	0.2 mm (0.0078 in.)

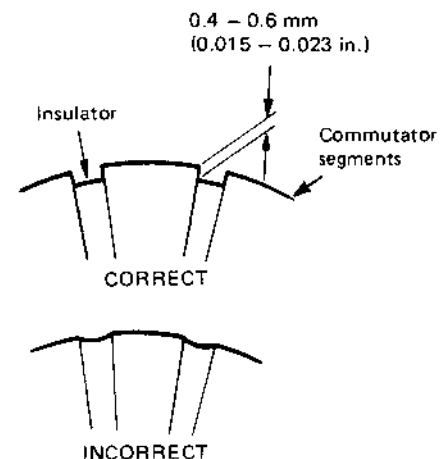


Fig. 9-14

### Ground test

Check commutator and armature coil core. If there is continuity, armature is grounded and must be replaced.

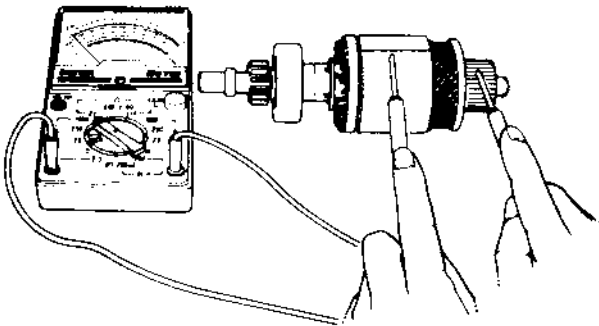


Fig. 9-15

### Open circuit test

Check for continuity between segments. If there is no continuity at any test point, there is an open circuit and armature must be replaced.

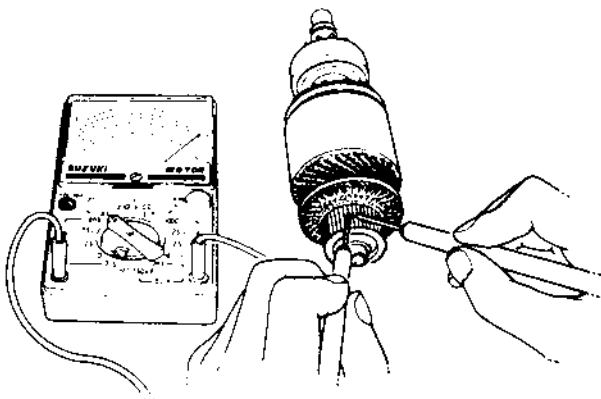


Fig. 9-16

## 2) Inspect Field Coil

### Open circuit test

Check for continuity between brush and bare surface. If there is continuity, field windings are grounded. The field coil must be replaced.

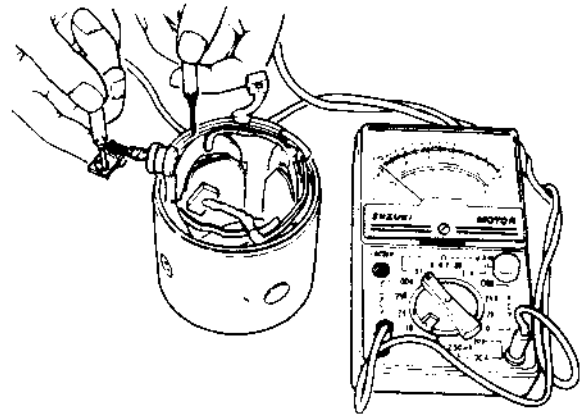


Fig. 9-17

## 3) Inspect Brush

Check brushes for wear. If below limit, replace brush.

	Standard	Limit
Brush length	17 mm (0.67 in.)	11.5 mm (0.45 in.)

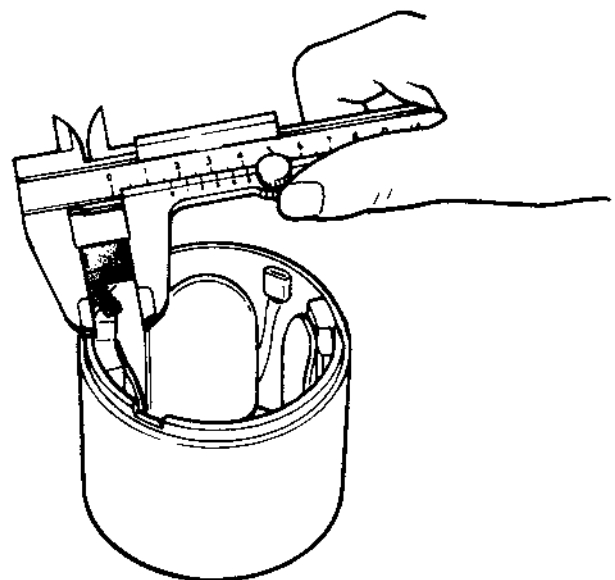


Fig. 9-18

#### 4) Inspect Brush Holder and Spring

Check movement of brush in brush holder. If brush movement within brush holder is sluggish, check brush holder for distortion and sliding faces for contamination.

Clean or correct as necessary.

Check for continuity across insulated brush holder (positive side) and grounded brush holder (negative side).

If continuity exists, brush holder is grounded due to defective insulation and should be replaced.

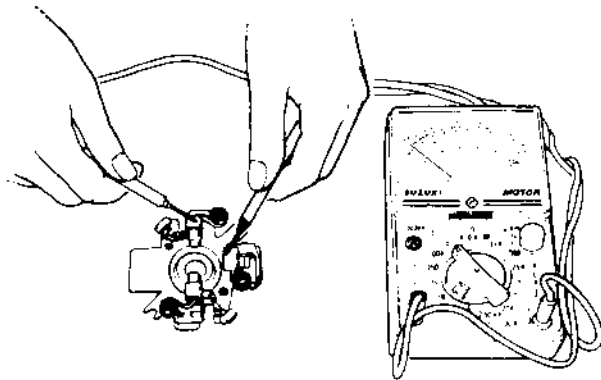


Fig. 9-19

Inspect brush spring for wear, damage or other abnormal conditions. Replace if necessary.

Brush spring tension	Standard	Limit
	1.6 kg (3.53 lb)	1.0 kg (2.20 lb)

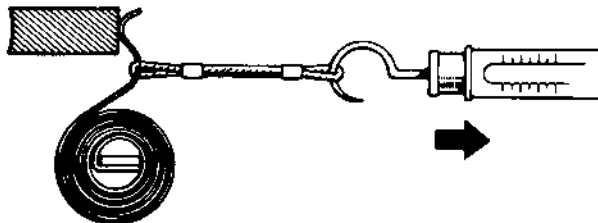


Fig. 9-20

#### 5) Inspect Drive Lever

Inspect drive lever for wear. Replace if necessary.

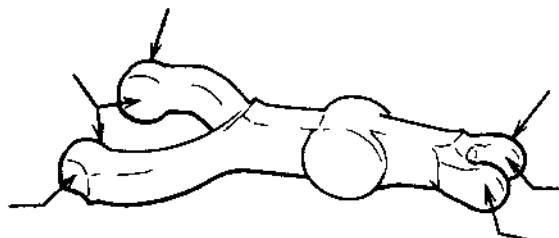


Fig. 9-21

#### 6) Inspect Pinion

Inspect pinion for wear, damage or other abnormal conditions. Check that clutch locks up when turned in direction of drive and rotates smoothly in reverse direction. Replace if necessary.

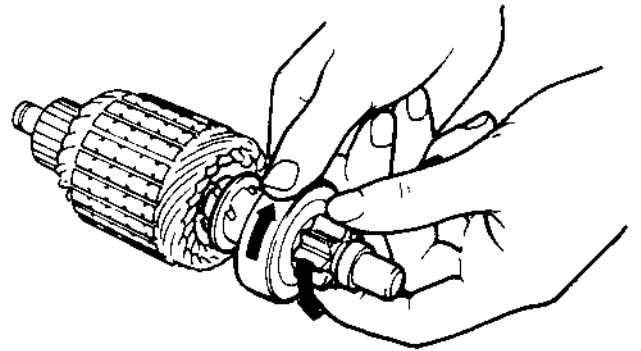


Fig. 9-22

Inspect spline teeth for wear or damage. Replace if necessary. Inspect pinion for smooth movement.

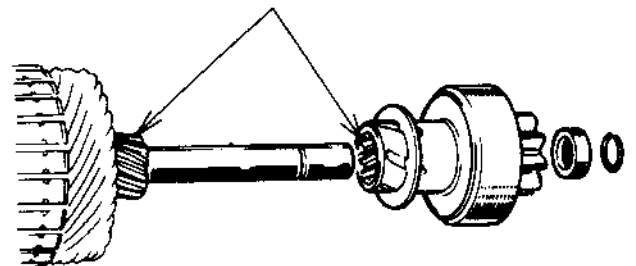


Fig. 9-23

#### 7) Inspect Armature Shaft Bush

Inspect bushes for wear or damage. Replace if necessary.

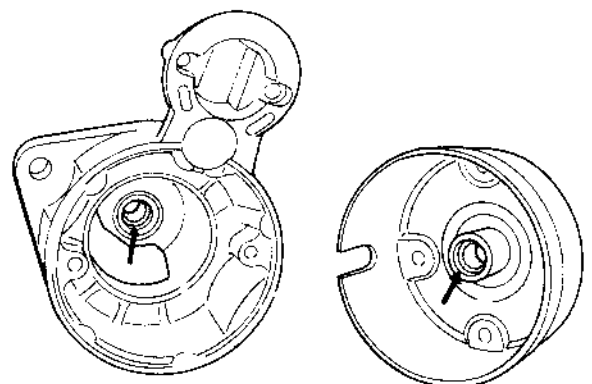


Fig. 9-24

### 8) Inspect Magnetic Switch

Push in plunger and release it. The plunger should return quickly to its original position. Replace if necessary.

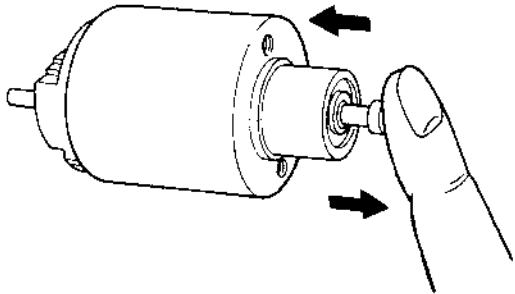


Fig. 9-25

### Pull-in coil open circuit test

Check for continuity across magnetic switch 'S' terminal and 'M' terminal. If no continuity exists, the coil is open and should be replaced.

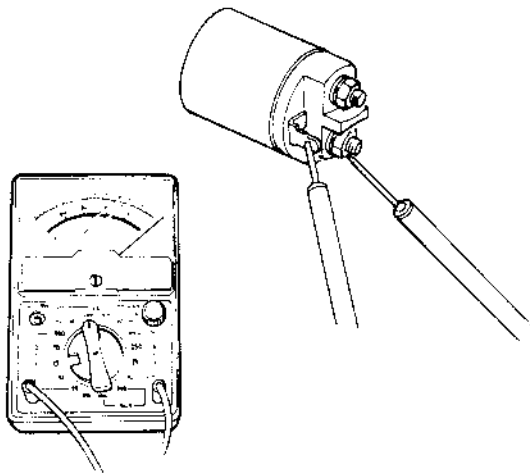


Fig. 9-26

### Hold in coil open circuit test

Check for continuity across magnetic switch 'S' terminal and coil case. If no continuity exists, the coil is open and should be replaced.

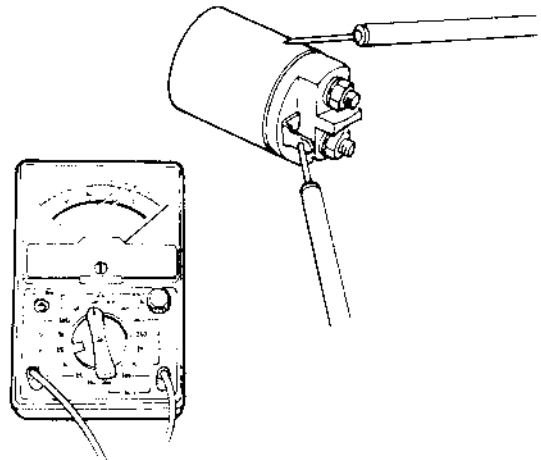
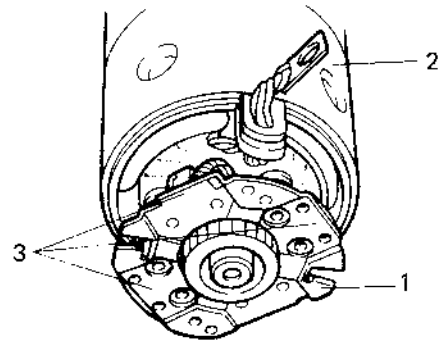


Fig. 9-27

### REASSEMBLY

Reverse disassembly procedure, using care on following points.

- When installing pinion drive lever, refer to Fig. 9-2 for its installation direction.
- When installing brush holder, be careful of brush position.



- 1. Brush holder
- 2. Yoke

- 3. Brush positions

Fig. 9-27-1



## 9-7. PERFORMANCE TEST

### IMPORTANT:

These tests must be performed within 3 – 5 seconds to avoid burning out the coil.

### 1) Pull-in Test

Connect battery to magnetic switch as shown. Check that plunger moves outward. If plunger does not move, replace magnetic switch.

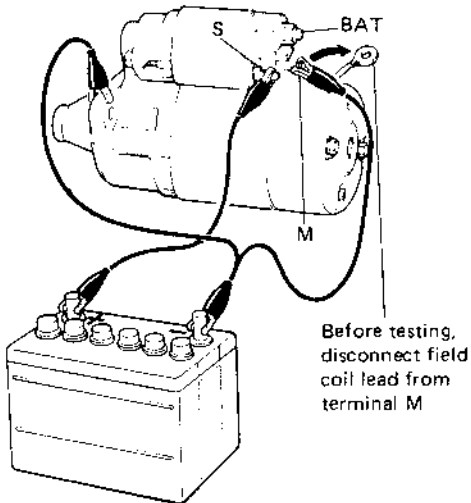


Fig. 9-28

### 2) Hold-in Test

While connected as above with plunger out, disconnect negative lead from terminal M. Check that plunger remains out. If plunger returns inward, replace magnetic switch.

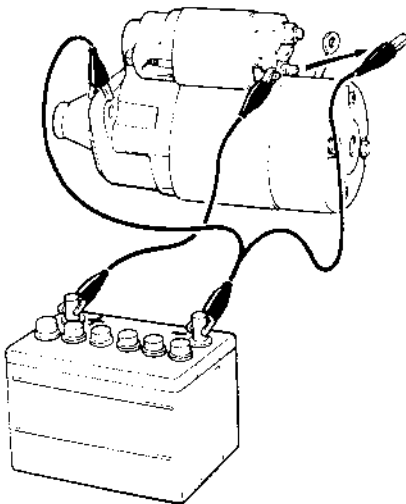


Fig. 9-29

### 3) Check Plunger Return

Disconnect negative lead from switch body. Check that plunger returns inward. If plunger does not return, replace magnetic switch.

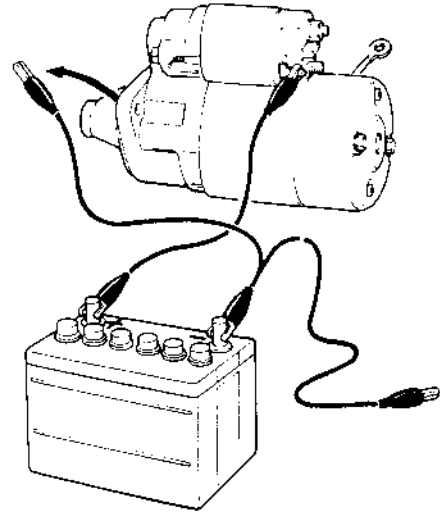


Fig. 9-30

### 4) No-load Performance Test

- Connect battery and ammeter to starter as shown.
- Check that starter rotates smoothly and steadily with pinion moving out. Check that ammeter reads the specified current.

Specified current
Less than 60 A at 11.5 V

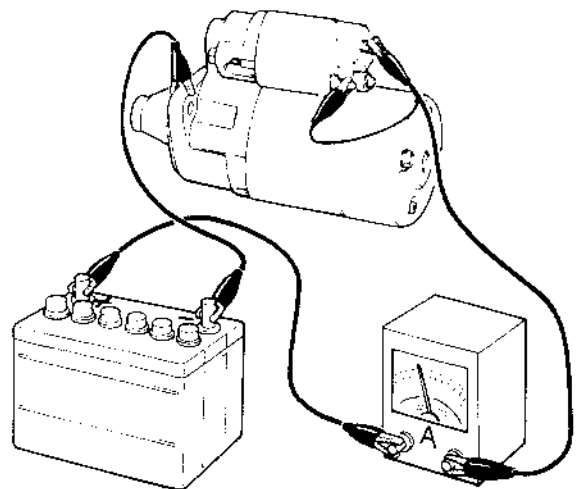


Fig. 9-31

## 9-8. CLUTCH SWITCH

Install clutch switch in such a way that clearance between thread end of clutch switch and clutch pedal (distance 3 in Fig. 9-32) satisfies following specification when clutch pedal is depressed fully.

Tighten clutch switch lock nut to specified torque.

Clutch switch thread end-to-clutch pedal clearance	1.0 – 1.5 mm (0.04 – 0.06 in)
--	----------------------------------

Tightening torque for clutch switch lock nut	N-m	kg-m	lb-ft
	10 – 15	1.0 – 1.5	7.5 – 10.5

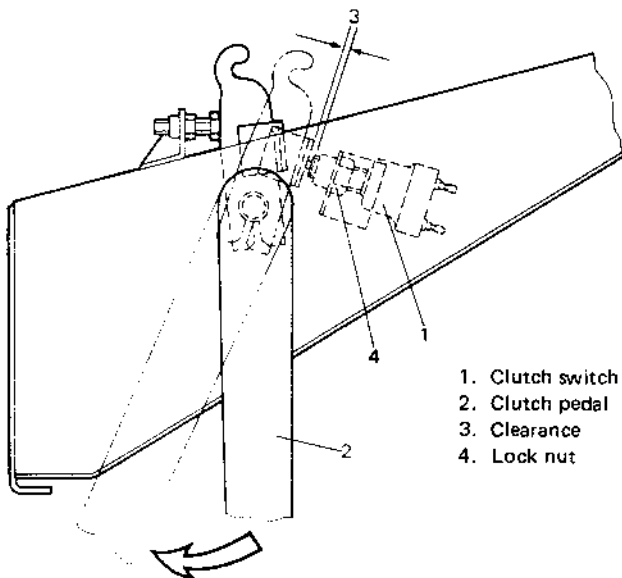


Fig. 9-32

**SECTION 10**  
**CHARGING SYSTEM**

**CONTENTS**

<b>10-1. ALTERNATOR</b> .....	<b>10-2</b>
GENERAL DESCRIPTION .....	<b>10-2</b>
DATA AND SPECIFICATION .....	<b>10-3</b>
DIAGNOSIS .....	<b>10-3</b>
REMOVAL .....	<b>10-6</b>
DISASSEMBLY .....	<b>10-6</b>
INSPECTION .....	<b>10-8</b>
ASSEMBLY .....	<b>10-9</b>
<b>10-2. BATTERY</b> .....	<b>10-10</b>
GENERAL DESCRIPTION .....	<b>10-10</b>
CARE OF THE BATTERY .....	<b>10-10</b>
REMOVE AND REPLACE .....	<b>10-12</b>
BATTERY CABLE .....	<b>10-12</b>

# 10-1. ALTERNATOR

## GENERAL DESCRIPTION

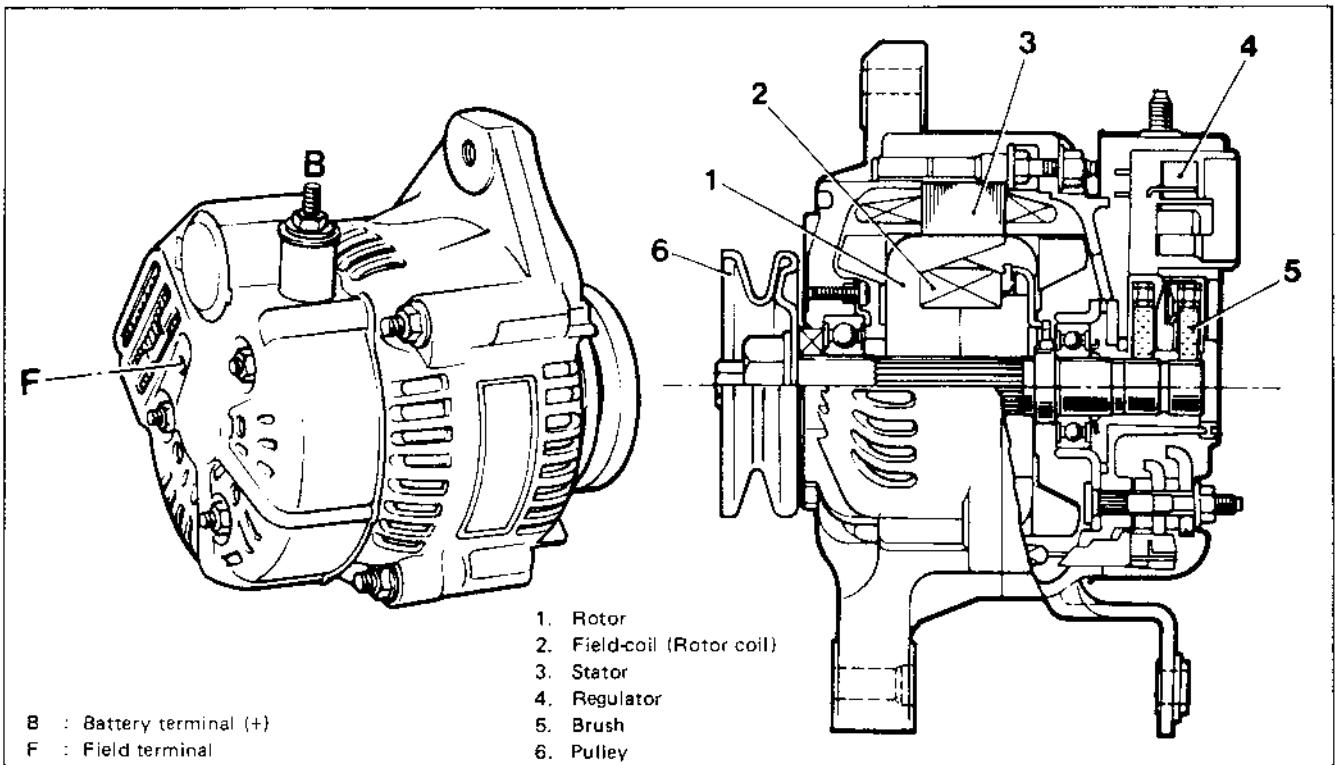


Fig. 10-1

The basic charging system is the IC integral regulator charging system. The internal components are connected electrically as shown below.

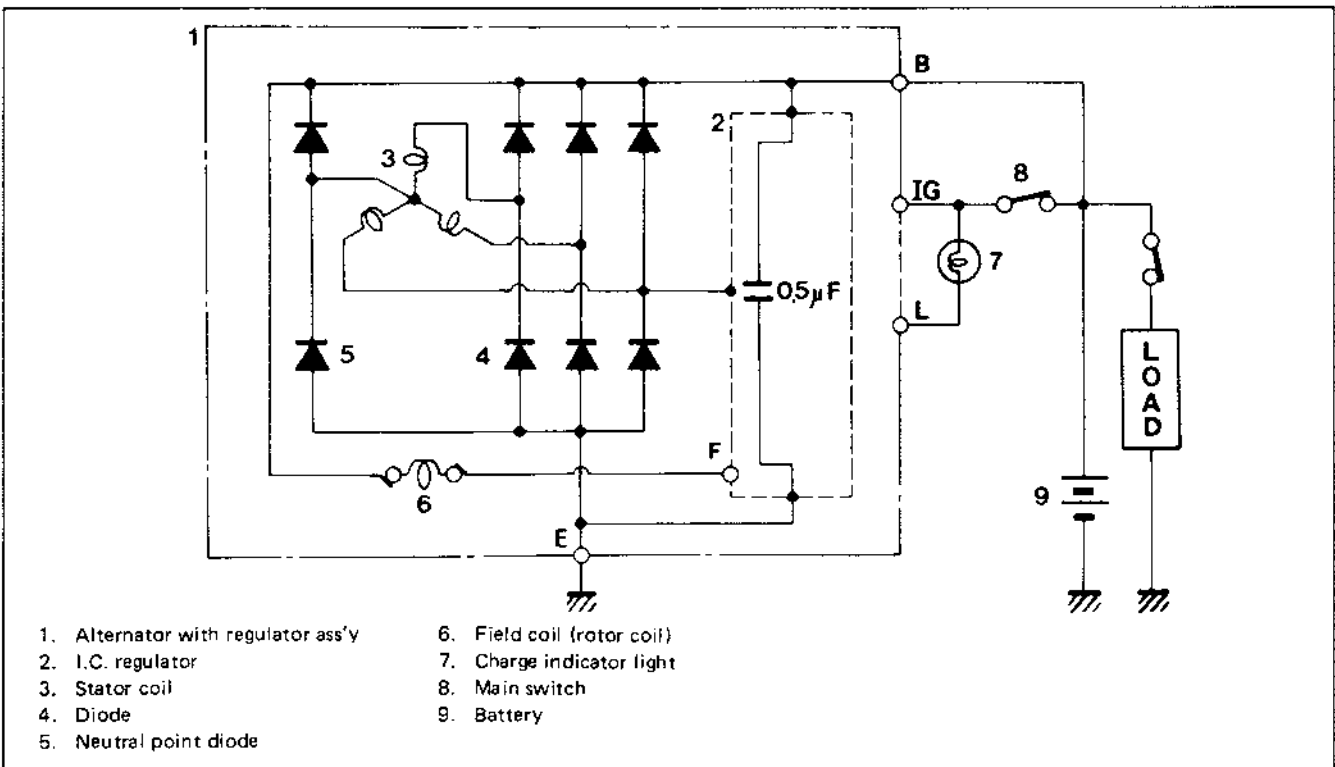


Fig. 10-2

The alternator features a solid state regulator that is mounted inside the alternator. All regulator components are enclosed into a solid mold, and this unit along with the brush holder assembly is attached to the slip ring end frame. The regulator voltage setting cannot be adjusted.

The alternator rotor bearings contain enough grease to eliminate the need for periodic lubrication. Two brushes carry current through the two slip rings to the field coil mounted on the rotor, and under normal conditions will provide long period of attention-free service.

The stator windings are assembled on the inside of a laminated core that forms part of the alternator frame. A rectifier bridge connected to the stator windings contains six diodes, and electrically changes the stator A.C. voltages to a D.C. voltage which appears at the generator output terminal.

The neutral diodes serve to convert the voltage fluctuation at the neutral point to direct current for increasing the alternator output.

A condenser mounted in the end frame protects the diodes from high voltages and suppresses radio noise.

#### DATA AND SPECIFICATION

Nominal operating voltage	12 volts
Max. alternator output	45A
Polarity	Negative ground
No-load alternator speed	1,110 rpm (r/min)
Regulated voltage	14.5 ± 0.3 V
Direction of rotation	Clockwise as viewed from pulley side
Maximum permissible alternator speed	15,000 rpm (r/min)
Working temperature range	-30 ~ 90° C (-22 ~ 194° F)
Rectification	Full wave rectification

#### Noisy Alternator

Noise from the alternator may be caused by a loose drive pulley, loose mounting bolts, worn or dirty bearings, defective diode, or defective stator.

#### DIAGNOSIS

A charging circuit wiring diagram for alternator connection is shown above. To avoid damage, always follow these precautions:

- 1) Do not mistake the polarities of IG terminal and L terminal.
- 2) Do not create short circuit between IG and L terminals. Always connect these terminals through a lamp.
- 3) Do not connect any load between L and E.

Trouble in the charging system will show up as one or more of the following conditions:

- a. Faulty indicator lamp operation.
- b. An undercharged battery as evidenced by slow cranking or indicator clear with red dot.
- c. An overcharged battery as evidenced by excessive spewing of electrolyte from the vents.

## A. Faulty Indicator Lamp Operation

Problem	Possible cause	Correction
Charge light does not light with ignition ON and engine off	Fuse blown Light burned out Wiring connection loose IC regulator faulty	Check fuse Replace light Tighten loose connections Replace IC regulator
Charge light does not go out with engine running (battery requires frequent re-charging)	Drive belt loose or worn Battery cables loose, corroded or worn IC regulator or alternator faulty Wiring faulty	Adjust or replace drive belt Repair or replace cables Check charging system Repair wiring

## B. Undercharged Battery

This condition, as shown by slow cranking or indicator clear with red dot, can be caused by one or more of the following conditions even though the indicator lamp may be operating normally. The following procedures also apply to cars with a voltmeter.

- 1) Insure that the undercharged condition has not been caused by accessories left on for extended period.
- 2) Check drive belt for proper tension.
- 3) If a battery defect is suspected, refer to latter part of this section, p. 10-10 ~ p. 10-11.
- 4) Inspect wiring for defects. Check all connections for tightness and cleanliness, including slip connectors at alternator and bulkhead, and battery cable connections at battery, starter and ignition ground cable.
- 5) Connect voltmeter and ammeter as shown in the diagram below.

### a. Voltmeter

Set between alternator (B) terminal and ground.

### b. Ammeter

Set between alternator (B) terminal and battery (+) terminal.

### 6) Current and voltage measurements

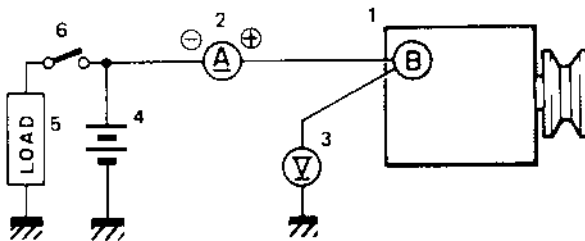
#### a. No-load check

Run engine from idling up to 2,000 r/min (rpm) and read meters.

Standard current	10 A maximum
Standard voltage	14.2 – 14.8 V (at 25° C, 77° F)

### NOTICE:

Consideration should be taken that the voltage will vary somewhat with regulator case temperature.



1. Generator
2. Ammeter
3. Volt meter
4. Battery
5. Load
6. Switch

Fig. 10-3

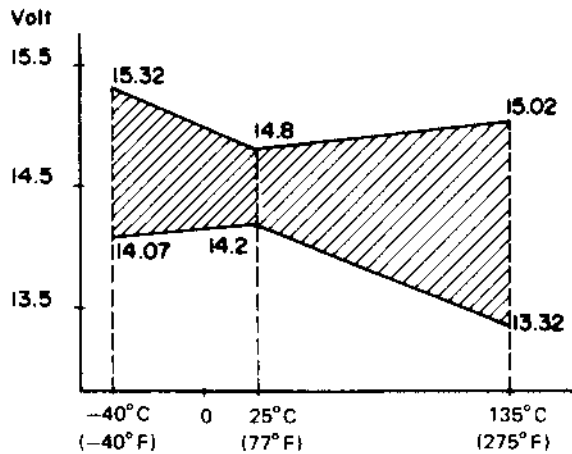


Fig. 10-4

If voltage is higher than standard value, replace IC regulator.

If voltage is below standard value, check IC regulator and alternator as follows:

Ground F terminal and start engine. Then measure voltage at B terminal.

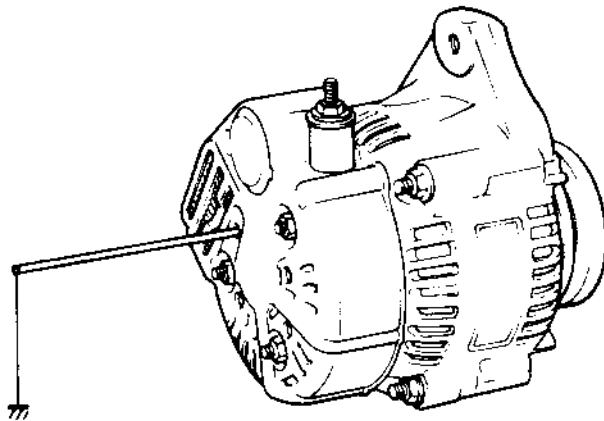


Fig. 10-5 Grounding terminal "F"

If voltage is above standard value, replace IC regulator.

If voltage is below standard value, check alternator.

b. Load check

Run engine at 2,000 r/min (rpm) and turn on headlamps and heater motor.

Measure current and if less than 20A, repair alternator.

C. Overcharged Battery

- 1) If an obvious overcharge condition exists as evidenced by excessive spewing of electrolyte, proceed to DISASSEMBLY under ALTERNATOR SERVICE on p. 10-6 and check field windings for grounds and shorts. If defective, replace rotor.

## ALTERNATOR SERVICE

### REMOVAL

- 1) Remove battery (-) terminal.
- 2) Disconnect alternator lead wires (coupler & white lead wire).
- 3) Unclamp brake pipe from pipe clamp on radiator under cover and remove radiator under cover.
- 4) Remove alternator mounting bolts and alternator drive belt adjusting bolt.
- 5) Take down alternator.

### DIASSEMBLY

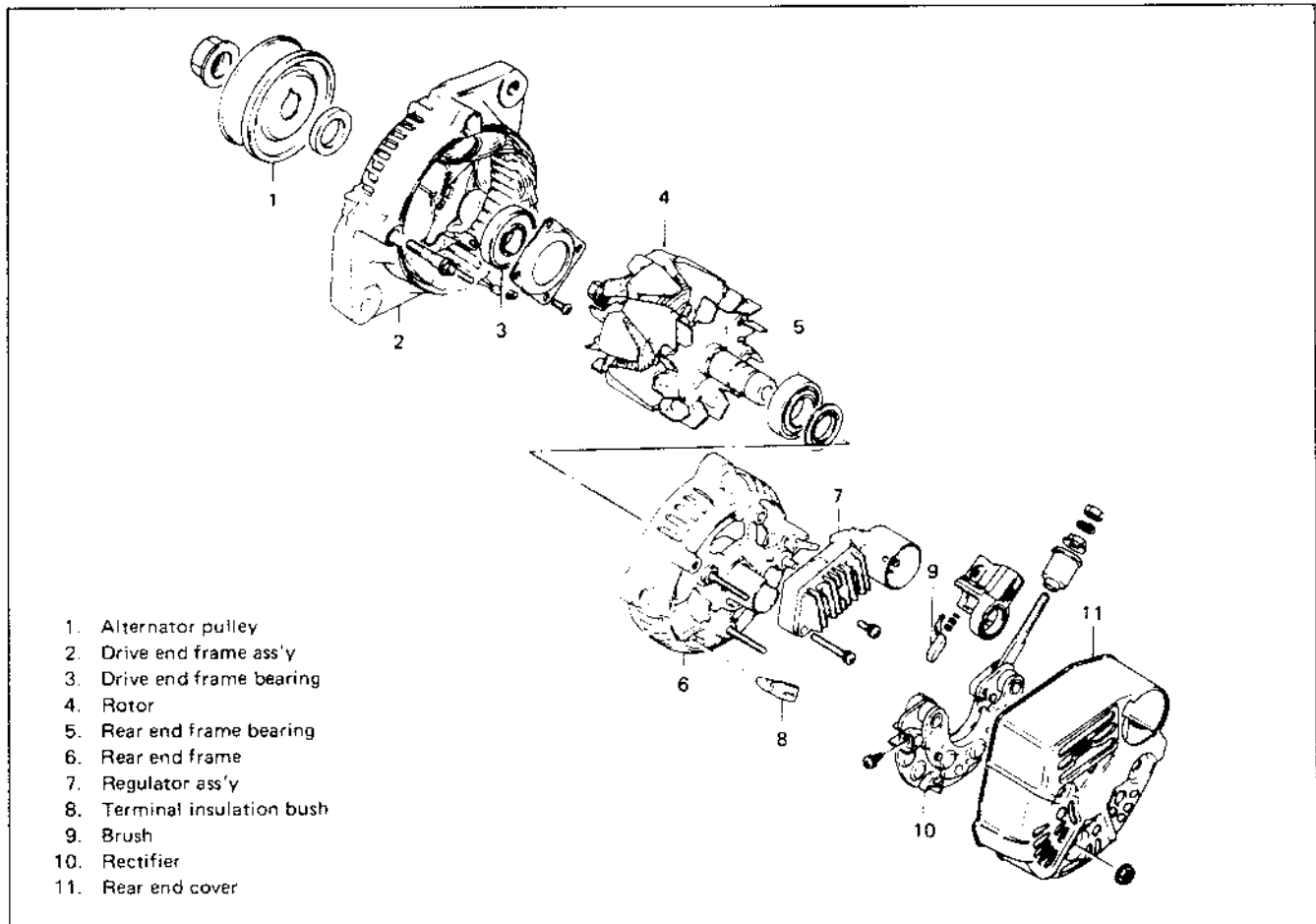
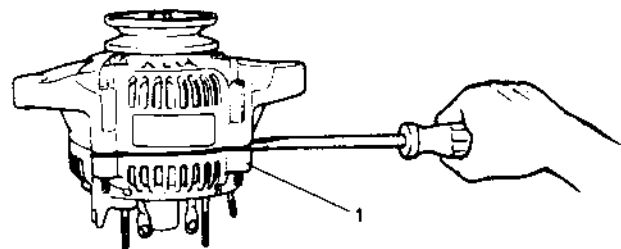


Fig. 10-6

- 1) Remove nut and take off B terminal insulator bushing.
- 2) Remove 3 nuts and take off rear end cover.
- 3) Remove 2 regulator mounting screws and 3 brush holder screws and take off regulator and brush holder.
- 4) Remove 4 stator coil terminal screws.
- 5) Remove rectifier holder together with I.C. regulator.
- 6) Remove 4 nuts and take off rear end frame.



1. Rear end frame

Fig. 10-7



7) Loosen alternator pulley nut and take off pulley.

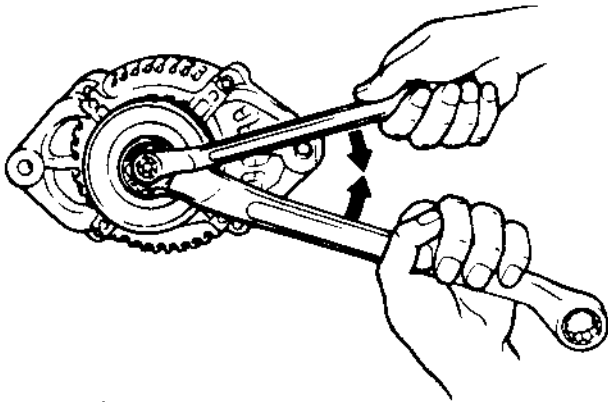


Fig. 10-8

8) Remove rotor from drive end frame.

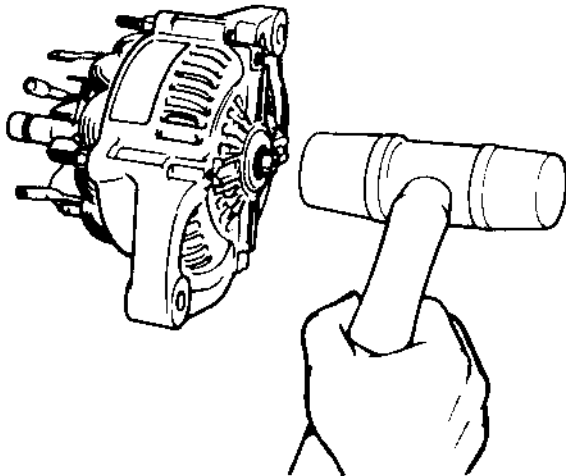
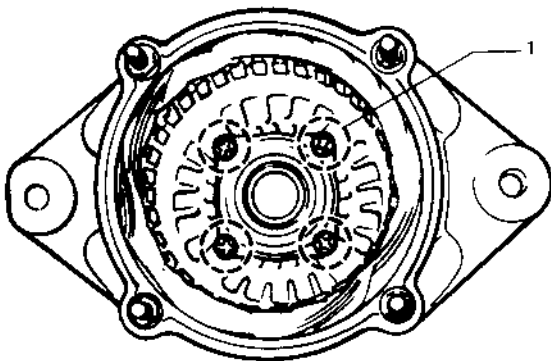


Fig. 10-9

9) When removing front end bearing, remove 4 4-mm bearing retainer screws.



1. Bearing retainer fitting screw

Fig. 10-10

10) When removing rear bearing, use bearing puller.

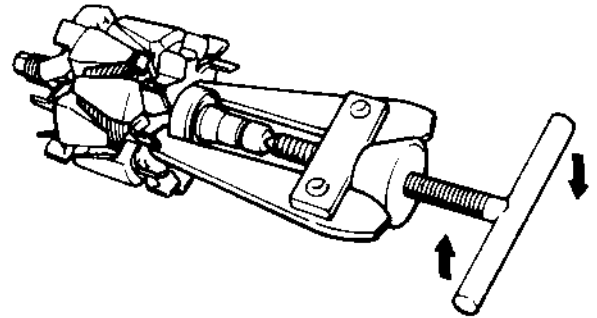


Fig. 10-11

## INSPECTION

### Rotor

- 1) Check rotor for no open circuits  
Using an ohmmeter, check for continuity between slip rings.

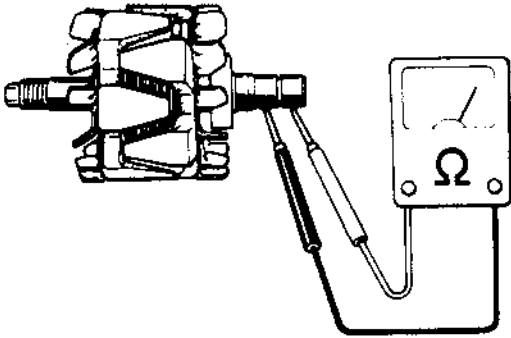


Fig. 10-12

Standard resistance	2.8 – 3.0 $\Omega$
---------------------	--------------------

If there is no continuity, replace rotor.

- 2) Check rotor for no grounds.  
Using an ohmmeter, check that there is no continuity between slip ring and rotor.  
If there is continuity, replace rotor.

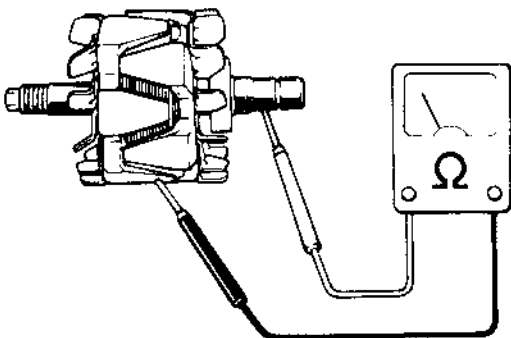


Fig. 10-13

- 3) Inspect slip rings  
Check slip rings for roughness or scoring. If rough or scored, replace rotor.

### Stator

- 1) Check stator for no open circuits  
Using an ohmmeter, check all leads for continuity. If there is no continuity, replace stator.

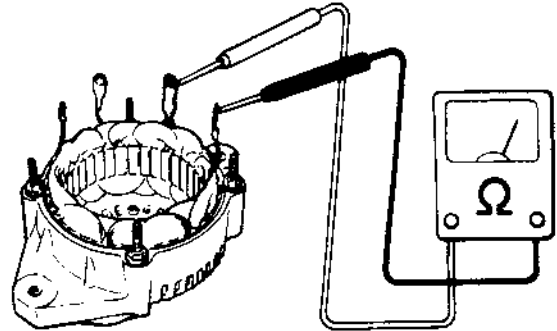


Fig. 10-14

- 2) Check stator for no grounds  
Using an ohmmeter, check that there is no continuity between coil leads and stator core.  
If there is continuity, replace rotor.

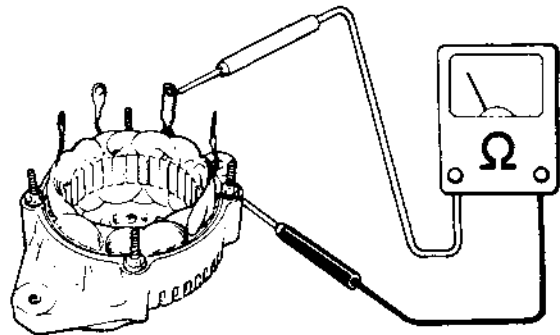


Fig. 10-15

### Brush and Brush holder

Check each brush for wear by measuring its length as shown. If brush is found worn down to service limit, replace brush with holder.

Brush length	Standard	Service limit
	11 mm (0.43 in)	5 mm (0.20 in)

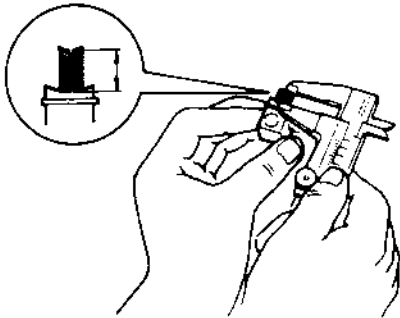


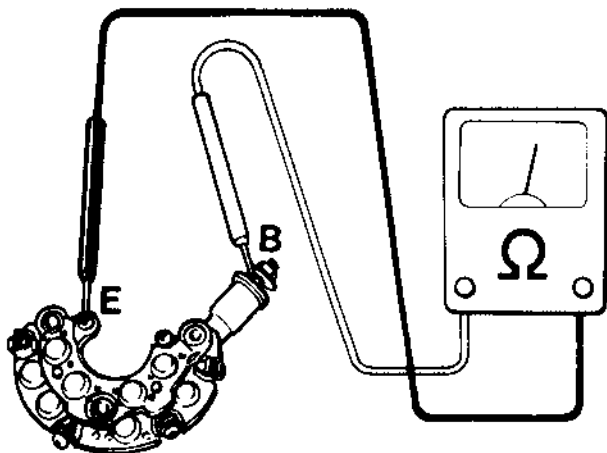
Fig. 10-16

### Rectifier

Using an ohmmeter, check continuity between "B" terminal and ground.

Put one tester lead to terminal "B" and the other lead to ground; then swap two leads. Of two tester indications, one should be about 10 ohms, meaning continuity, and the other should be infinity (non continuity).

If not, replace rectifier assembly.



B : Battery terminal  
E : Earth

Fig. 10-17

### Condenser

Check condenser capacity in regulator.

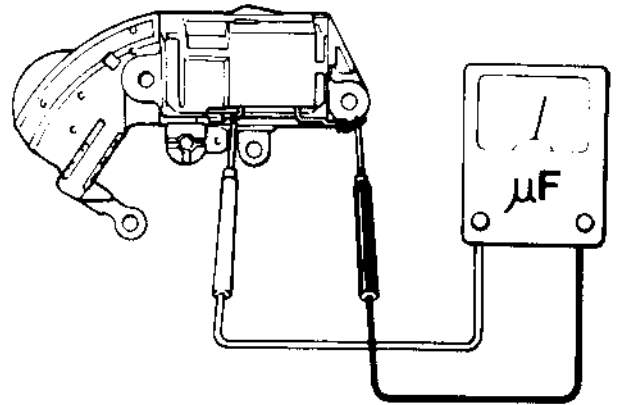


Fig. 10-18

Condenser capacity	0.5 $\mu$ F
--------------------	-------------

### ASSEMBLY

Reverse disassembly procedure, using care on following points.

- 1) Use a press when forcing bearing into rotor shaft or drive end frame.

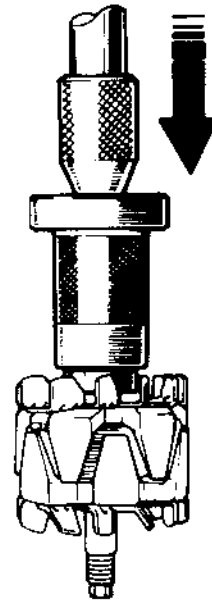


Fig. 10-19

- 2) Alternator pulley tightening torque.

Tightening torque		
50 – 65 N·m	5.0 – 6.5 kg·m	37 – 47 lb·ft

3) Make sure to assemble stator terminal insulator properly.

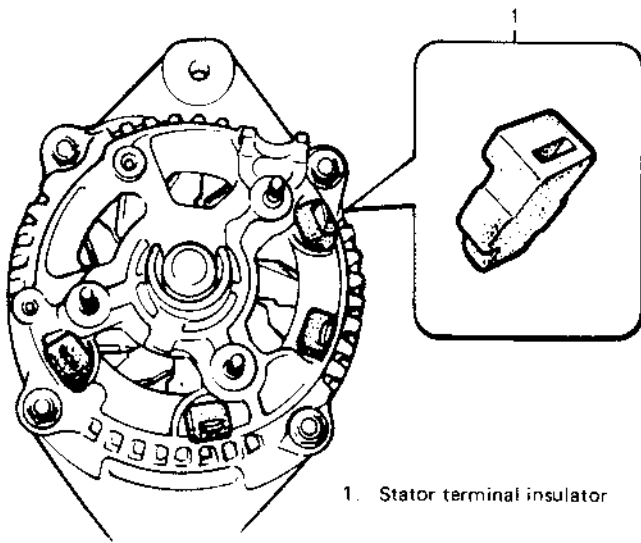


Fig. 10-20

4) Alternator V belt tension.

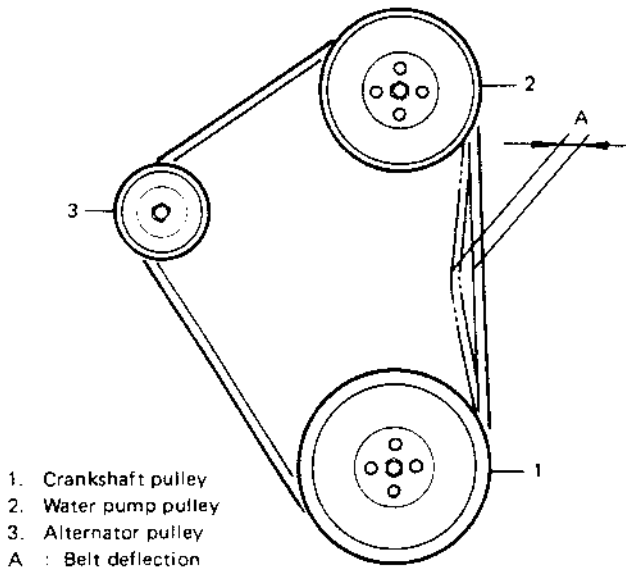


Fig. 10-21

Drive belt deflection (Under 10 kg thumb pressure)	6 – 9 mm (0.24 – 0.35 in)
---	------------------------------

**NOTICE:**

Clamp brake pipe with pipe clamp on radiator under cover after installing radiator under cover.

## 10-2. BATTERY

### GENERAL DESCRIPTION

The battery has three major functions in the electrical system. First, it is a source of electrical energy for cranking the engine. Second it acts as a voltage stabilizer for the electrical system. And third, it can, for a limited time, provide energy when the electrical load exceeds the output of the generator.

Each new car shipped from the factory is fitted with following battery.

Model	55B24R (S) (NX100-S6 (S))
Rated capacity	137 kC (38 Ah)/5HR

This battery is completely sealed, except for six small vent holes in the top. These vent holes allows the small amount of gas produced in the battery to escape. This sealed battery has a built-in temperature compensated indicator in the top of the battery.

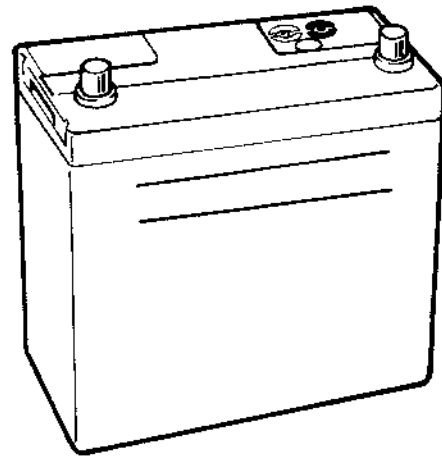


Fig. 10-22

### CARE OF THE BATTERY

#### [Electrolyte freezing]

The freezing point of electrolyte depends on its specific gravity. Since freezing may ruin a battery, it should be protected against freezing by keeping it in a fully charged condition.

**[Carrier and hold-down]**

The battery carrier and hold-down clamp should be clean and free from corrosion before installing the battery. The carrier should be in good condition so that it will support the battery securely and keep it level.

Make certain there are no parts in carrier before installing the battery.

To prevent the battery from shaking in its carrier, the hold-down bolts should be tight but not over tightened.

**[Visual inspection]**

Check for obvious damage, such as cracked or broken case or cover, that could permit loss of electrolyte. If obvious damage is noted, replace the battery. Determine cause of damage and correct as needed.

Check the battery terminal and cords for corrosion. If any, it should be cleaned.

**[Built-in indicator]**

This sealed battery has a built-in temperature compensated indicator in the top of the battery. This indicator is to be used with the following diagnostic procedure. When observing the indicator, make sure that the battery has a clean top. A light may be needed in some poorly-lit areas.

Under normal operation, two indications can be seen



1		OK
2		CHARGING NECESSARY

Fig. 10-23

**• Clear with Red Dot**

This means the discharging battery. In this case, charge the battery until the indicator will be blue with red dot. The charging and electrical systems should also be checked at this time. If any defective is found, correct it. While charging it, if the battery feels hot 52°C (125°F), or if violent gassing or spewing of electrolyte through the vent hole occurs, discontinue charging or reduce charging rate.

**[Jump starting in case of emergency with auxiliary (booster) battery]**

**NOTICE:**

- Do not push or tow the vehicle to start. Damage to the emission system and/or to other parts of the vehicle may result.
- Both booster and discharged battery should be treated carefully when using jumper cables. Follow the procedure outlined below, being careful not to cause sparks:

**CAUTION:**

- Departure from these conditions or the procedure below could result in: (1) Serious personal injury (particularly to eyes) or property damage from such causes as battery explosion, battery acid, or electrical burns; and/or (2) damage to electronic components of either vehicle.
- Never expose battery to open flame or electric spark-batteries generate a gas which is flammable and explosive.
- Remove rings, watches, and other jewelry. Wear approved eye protection.
- Do not allow battery fluid to contact eyes, skin, fabrics, or painted surfaces - fluid is a corrosive acid. Flush any contacted area with water immediately and thoroughly. Be careful that metal tools or jumper cables do not contact the positive battery terminal (or metal in contact with it) and any other metal on the car, because a short circuit could occur. Batteries should always be kept out of the reach of children.

- 1) Set parking brake and place transmission in neutral. Turn off the ignition, turn off lights and all other electrical loads.
- 2) Check electrolyte level. If level is below low level line, replace battery.

**NOTICE:**

When jump starting an engine with charging equipment, be sure equipment used is 12-volt and negative ground. Do not use 24-volt charging equipment. Using each equipment can cause serious damage to the electrical system or electronic parts.

- 3) Attach the end of one jumper cable to the positive terminal of the booster battery and the other end of the same cable to the positive terminal of the discharged battery. Do not permit vehicles to touch each other as this could cause a ground connection and counteract the benefits of this procedure. (Use 12-volt battery only to jump start the engine).
- 4) Attach one end of the remaining negative cable to the negative terminal of the booster battery, and the other end to a solid engine ground (such as A/C compressor bracket or generator mounting bracket) at least 18 inches from the battery of the vehicle being started (DO NOT CONNECT DIRECTLY TO THE NEGATIVE TERMINAL OF THE DEAD BATTERY).
- 5) Start the engine of the vehicle that is providing the jump start and turn off electrical accessories. Then start the engine in the car with the discharged battery.
- 6) Reverse these directions exactly when removing the jumper cables. The negative cable must be disconnected from the engine that was jump started first.

## REMOVE AND REPLACE

When handling a battery, the following safety precautions should be followed:

- 1) Hydrogen gas is produced by the battery. A flame or spark near the battery may cause the gas to ignite.
- 2) Battery fluid is highly acidic. Avoid spilling on clothing or other fabric. Any spilled electrolyte should be flushed with large quantity of water and cleaned immediately. To remove or replace a battery, always disconnect the negative cable first, then the positive cable.

## BATTERY CABLES

Connect battery cables as shown in the figure below and make sure to properly tighten all terminals.

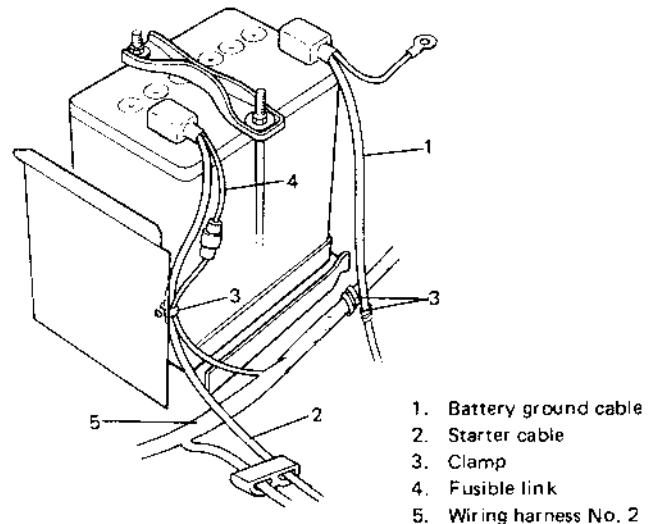


Fig. 10-24

## SECTION 11

# CLUTCH

### CONTENTS

11-1. GENERAL DESCRIPTION .....	11-2
11-2. REMOVAL .....	11-4
11-3. INSPECTION OF COMPONENTS .....	11-5
11-4. INSTALLATION .....	11-7
11-5. MAINTENANCE SERVICES .....	11-8
11-6. RECOMMENDED TORQUE SPECIFICATION .....	11-10

## 11-1. GENERAL DESCRIPTION

The clutch is a diaphragm-spring clutch of a dry single disc type. The diaphragm spring is of a tapering-finger type, which is a solid ring in the outer diameter part, with a series of tapering fingers pointing inward. The disc, carrying four torsional coil springs, is slidably mounted on the transmission input shaft with a serration fit.

The clutch cover is secured to the flywheel, and carries the diaphragm spring in such a way that the peripheral edge of the spring pushes on the pressure plate against the flywheel (with the disc in between), when the clutch release bearing is held back: This is the engaged condition of the clutch.

Depressing the clutch pedal causes the release bearing to advance and push on the tips of the tapering fingers of the diaphragm spring. When this happens, the diaphragm spring pulls the pressure plate away from the flywheel, thereby interrupting the flow of drive from flywheel through clutch disc to transmission input shaft.

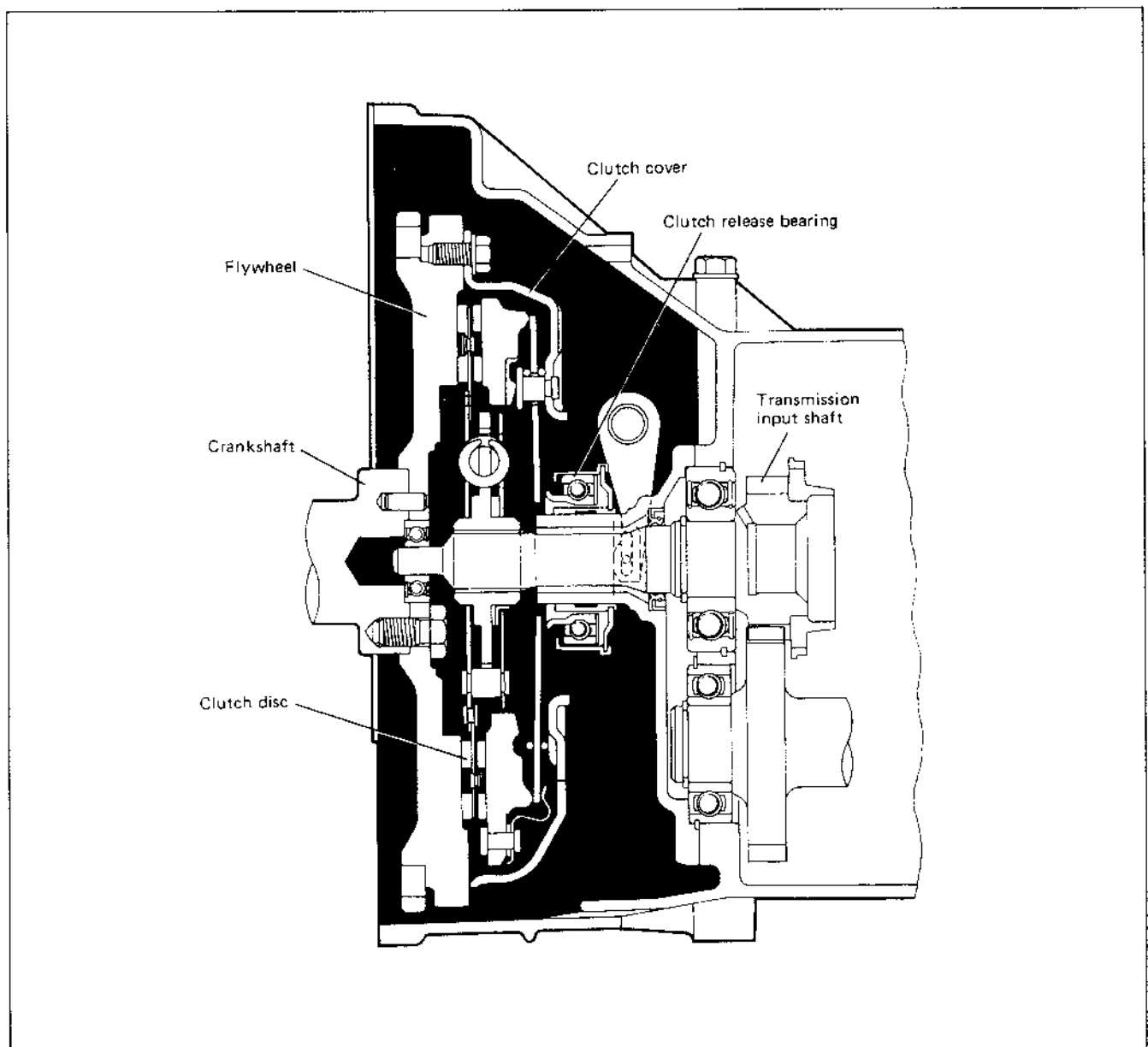


Fig. 11-1



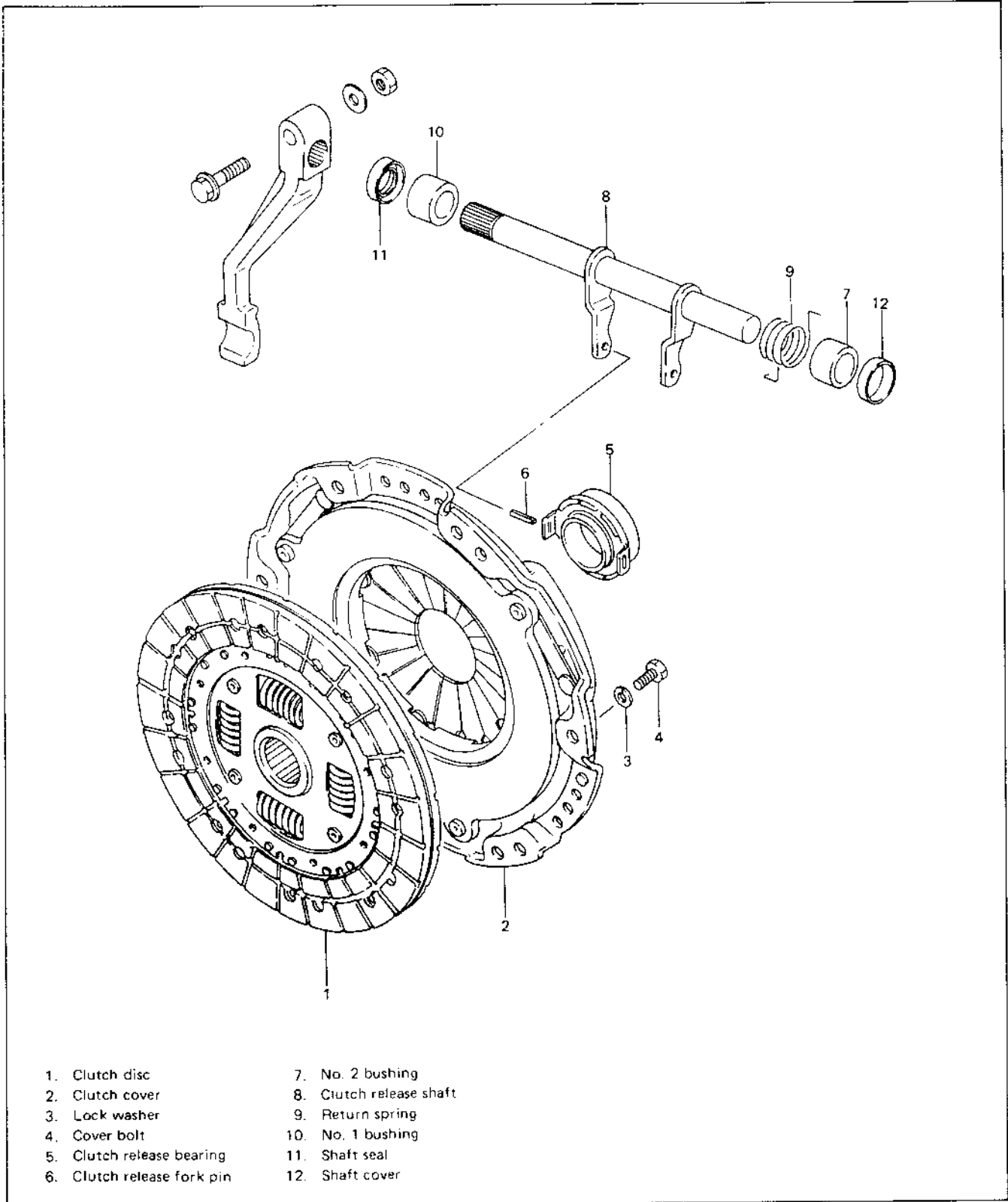


Fig. 11-2

## 11-2. REMOVAL

Removal of clutch presupposes that the transmission has been dismantled according to the method outlined in SECTION 13 TRANSMISSION.

### Clutch Cover and Disc

Remove 6 bolts securing clutch cover to flywheel, and take off clutch cover and disc.

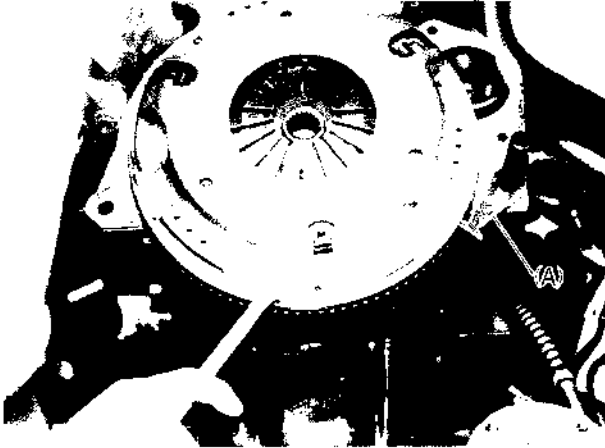


Fig. 11-3 Ⓐ Special tool (Flywheel holder 09924-17810)

### Clutch Release Bearing

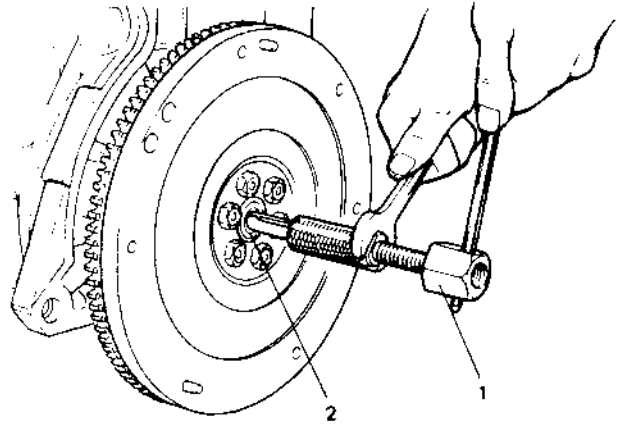
Remove clutch release bearing from transmission input shaft bearing retainer.



Fig. 11-4

### Input Shaft End Bearing

Use bearing remover (special tool) for removal of this bearing.



1. Special tool (Bearing remover 09917-58010)
2. Input shaft bearing

Fig. 11-5

### Clutch Release Shaft Bushes

For replacement of bushes, refer to p. 13-5 of SECTION 13 TRANSMISSION.

### 11-3. INSPECTION OF COMPONENTS

#### Clutch Disc Facing Surface Condition

A burnt or glazed (glass-like surface) facing can be reconditioned by grinding it with No. 120 – 200 sandpaper. If surface is in bad condition beyond repair, replace whole clutch disc assembly.

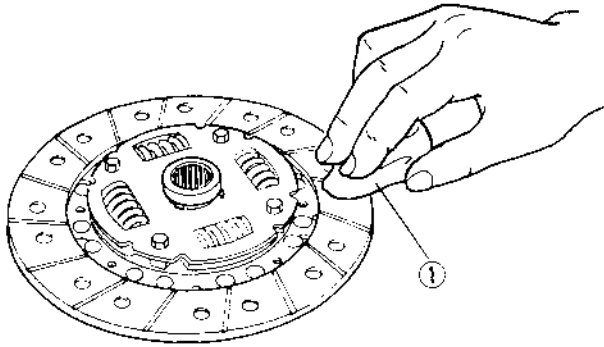


Fig. 11-6 ① Sandpaper

#### Clutch Facing Wear

Check wear of facing by measuring depth of each rivet head depression, i.e. distance between rivet head and facing surface. If depressing is found to have reached service limit at any of the holes, replace clutch disc assembly.

Rivet head depression	Standard	Service limit
	1.2 mm (0.05 in.)	0.5 mm (0.02 in.)

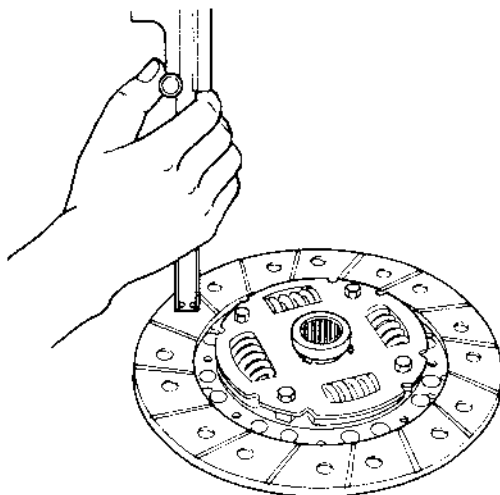


Fig. 11-7

#### Backlash in Disc Serration Fit

Check backlash by turning disc back and forth as mounted on transmission input shaft. Replace disc assembly if backlash is noted to exceed service limit. Backlash here is a circular displacement as measured with a dial indicator.

Backlash in serration fit	Service limit
	0.8 mm (0.03 in.)

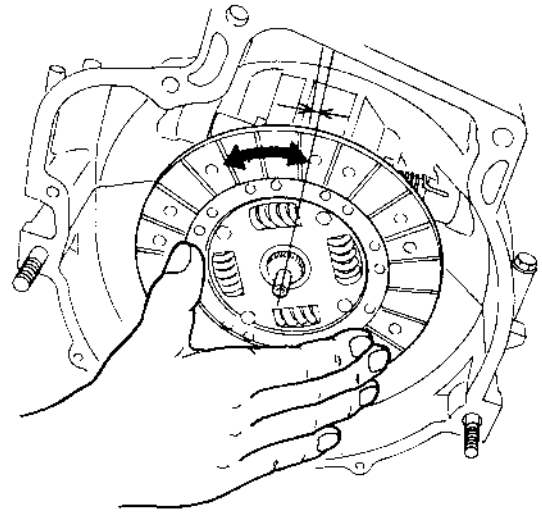


Fig. 11-8

#### Clutch Cover

Inspect clutch cover for evidence of diaphragm spring rivets getting loose. If rivets are loose or are getting loose, replace cover assembly as such cover makes rattling noise when clutch pedal is depressed.

Inspect tips of tapering fingers (to which the release bearing exerts a push to disengage clutch) for wear. If tips are worn excessively, replace cover assembly.

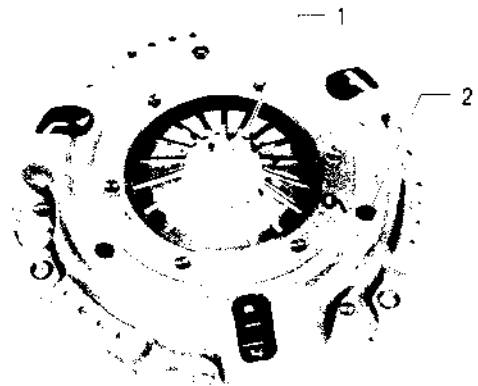


Fig. 11-9 ① Spring wear; ② Rivet

### Release Bearing

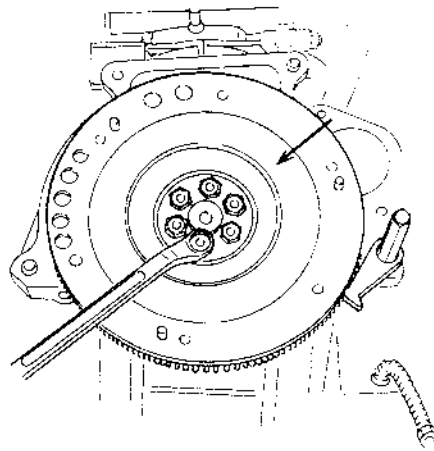
Replace release bearing if it sticks, rattles or makes abnormal noise when spun and turned by hand.



*Fig. 11-10*

### Flywheel

Check surface contacting clutch disc for any wear or damage.



*Fig. 11-12*

### Input Shaft Bearing

Replace input shaft bearing if it sticks, rattles or makes abnormal noise when spun and turned by hand.



*Fig. 11-11*

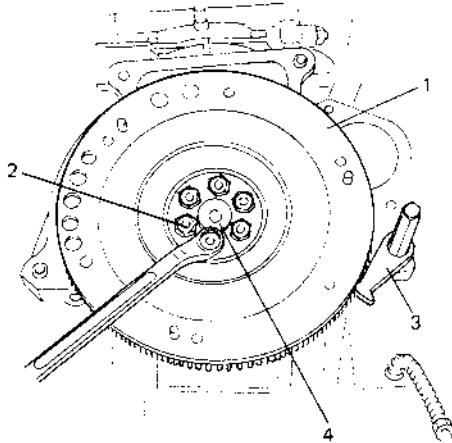
## 11-4. INSTALLATION

Install clutch by reversing removal procedure. Some important steps will be explained below.

### Flywheel

- 1) Tighten bolts to specification.

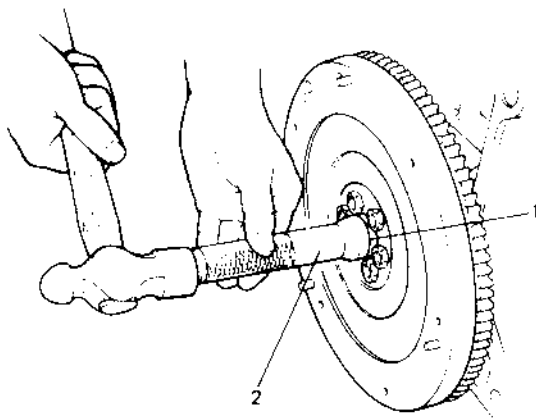
Tightening torque for flywheel bolts	N·m	kg·m	lb·ft
	57 – 65	5.7 – 6.5	41.5 – 47.0



1. Flywheel
2. Flywheel bolt
3. Special tool (Flywheel holder 09924-17810)
4. Input shaft bearing

Fig. 11-13

- 2) Install input shaft end bearing to flywheel using bearing installer (special tool).



1. Input shaft bearing
2. Special tool (Input shaft bearing installer 09925-98210)

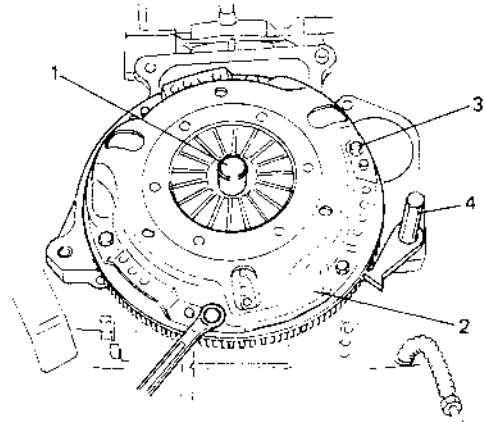
Fig. 11-13-1

### Clutch Disc and Clutch Cover

Using special tool (clutch center guide), install clutch disc and clutch cover.

Tighten clutch cover bolts to specification using special tool (Flywheel holder).

Tightening torque for clutch cover bolts	N·m	kg·m	lb·ft
	18 – 28	1.8 – 2.8	13.5 – 20.0



1. Special tool (Clutch center guide 09923-38220)
2. Clutch cover
3. Clutch cover bolt
4. Special tool (Flywheel holder 09924-17810)

Fig. 11-14

### Clutch Release Bearing

Before installing retainer, apply grease to its inner surface.



Fig. 11-15 ① Grease (SUZUKI SUPER GREASE "A")

**Clutch Release Shaft Fork**  
Apply grease to end of fork.



Fig. 11-16 ① Grease (SUZUKI SUPER GREASE "A")

**Clutch Release Arm**

Align two punch marks when installing clutch release arm on clutch release shaft.

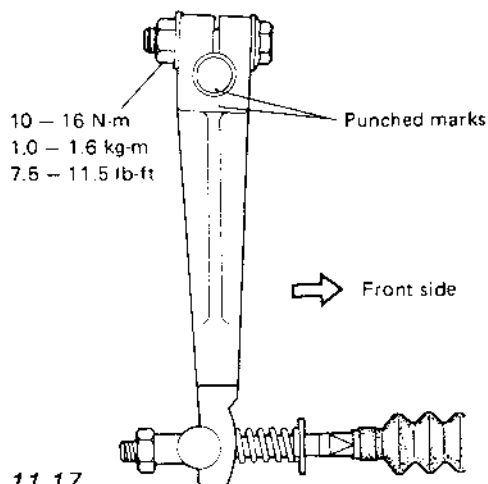


Fig. 11-17

**Clutch Release Shaft Bushes**

For reinstallation of bushes, refer to p. 13-5 in SECTION 13 TRANSMISSION of this manual.

**Transmission**

For remounting transmission, refer to p. 13-4 in SECTION 13 TRANSMISSION of this manual and reverse dismounting procedure.

Before remounting transmission ass'y, apply grease (SUZUKI SUPER GREASE I) to input shaft. Refer to Fig. 13-84.

**11-5. MAINTENANCE SERVICES**

**Clutch Pedal Height**

Adjust height of clutch pedal with clutch pedal stop bolt so that pedal is level with brake pedal. Tighten lock nut after adjusting.

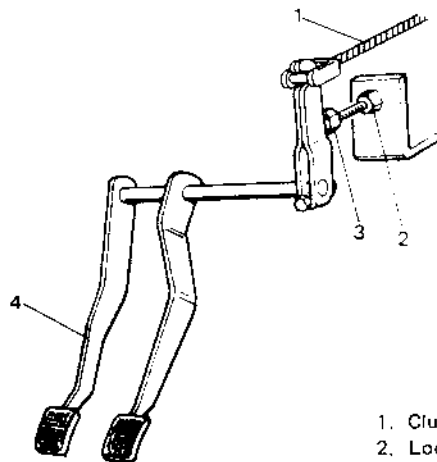


Fig. 11-18

- 1. Clutch cable
- 2. Lock nut
- 3. Adjust bolt
- 4. Clutch pedal

**Clutch Pedal Free Travel**

1) Depress clutch pedal, stop the moment clutch resistance is felt, and measure distance (clutch pedal free travel). Free travel should be within the following specification.

Clutch pedal free travel	20 - 30 mm (0.8 - 1.1 in.)
--------------------------	-------------------------------

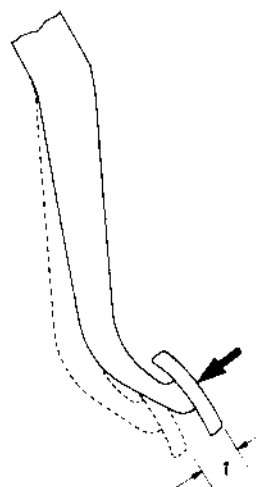


Fig. 11-19

- 1. Clutch pedal free travel

2) If free travel is out of specification, adjust it with clutch cable outer nuts.

**NOTICE:**

After adjusting free travel, make sure that the clutch cable end protrudes at least 5 mm from joint nut.

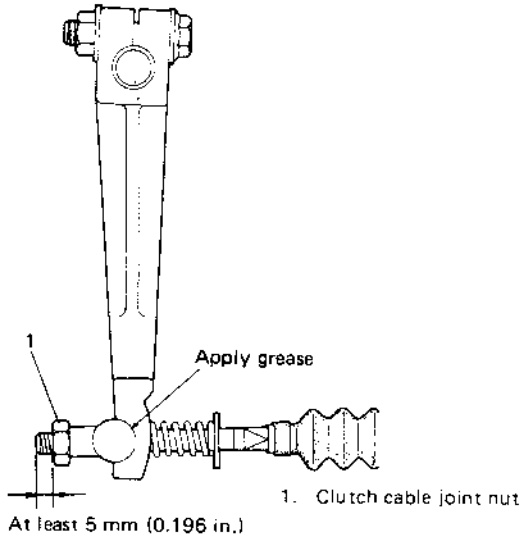


Fig. 11-20

**Clutch Cable Lubrication**

Apply grease to hook part ① of clutch cable.

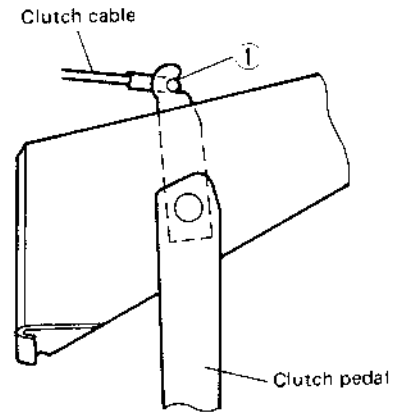


Fig. 11-21

**Clutch Cable Routing**

1) For left-hand side steering vehicle.

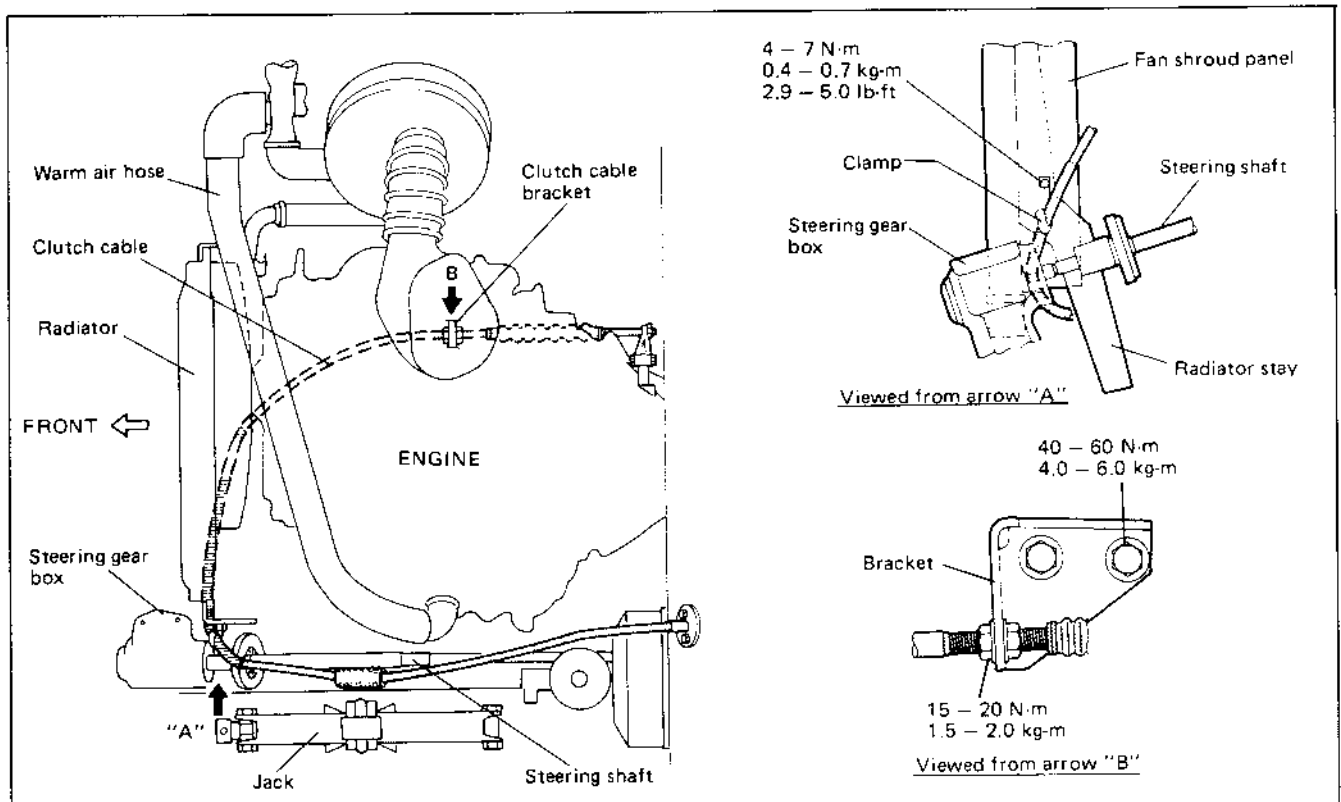


Fig. 11-22

2) For right-hand side steering vehicle.

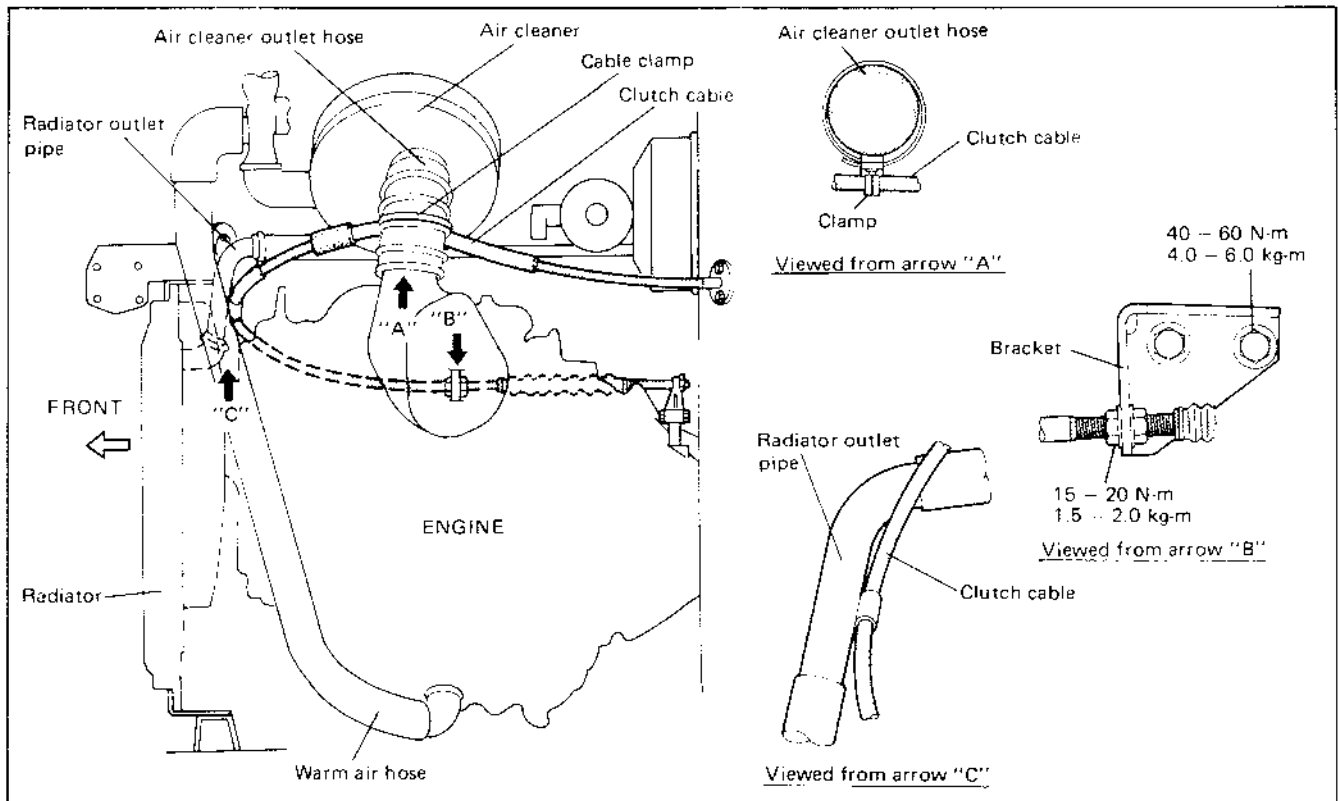


Fig. 11-23

## 11-6. RECOMMENDED TORQUE SPECIFICATION

Be sure to torque each nut or bolt, if loosened, to specification given below.

If specified tightening torque for particular bolt or nut is not included here, refer to p. 0-12 of this manual.

Fastening Parts	Tightening torque		
	N-m	kg-m	lb-ft
1. Flywheel bolts	57 – 65	5.7 – 6.5	41.5 – 47.0
2. Clutch cover bolts	18 – 28	1.8 – 2.8	13.5 – 20.0
3. Clutch release arm bolt and nut	10 – 16	1.0 – 1.6	7.5 – 11.5



## SECTION 12

# GEAR SHIFTING CONTROL

### CONTENTS

12-1. GENERAL DESCRIPTION .....	12-2
12-2. REMOVAL .....	12-3
GEAR SHIFT LEVER.....	12-3
GEAR SHIFT LEVER SELECT GUIDE PINS .....	12-3
12-3. INSPECTION OF COMPONENTS .....	12-4
GEAR SHIFT LEVER .....	12-4
REVERSE & LOW SPEED SELECT GUIDE PINS .....	12-4
GEAR SHIFT FORK SHAFT .....	12-4
12-4. INSTALLATION .....	12-5
REVERSE & LOW SPEED GUIDE PINS .....	12-5
GEAR SHIFT LEVER CASE.....	12-5
GEAR SHIFT CONTROL LEVER SEAT .....	12-6
TIGHTENING TORQUE & GREASING POINT .....	12-6

## 12-1. GENERAL DESCRIPTION

In this gear shifting control system, by its mechanical structure, the movement of the gear shift lever, which is located beside the driver's seat, directly actuates the gear shift fork shaft to shift the gear into the selected position. This system consists of the following parts.

1. Gear shift lever knob
2. Gear shift lever
3. Gear shift lever boot No. 2
4. Gear shift lever boot No. 1
5. Gear shift lever case cover
6. Gear shift lever locating bolt
7. Gear shift lever case
8. Reverse select pin screw
9. Reverse select locating springs
10. Reverse select locating ball
11. Reverse select guide pin
12. Reverse gear shift fork shaft
13. High speed gear shift fork shaft
14. Select return springs
15. Low speed select pin bolt
16. Low speed select guide pin
17. Low speed gear shift fork shaft
18. Gear shift lever wave washer
19. Gear shift lever seat

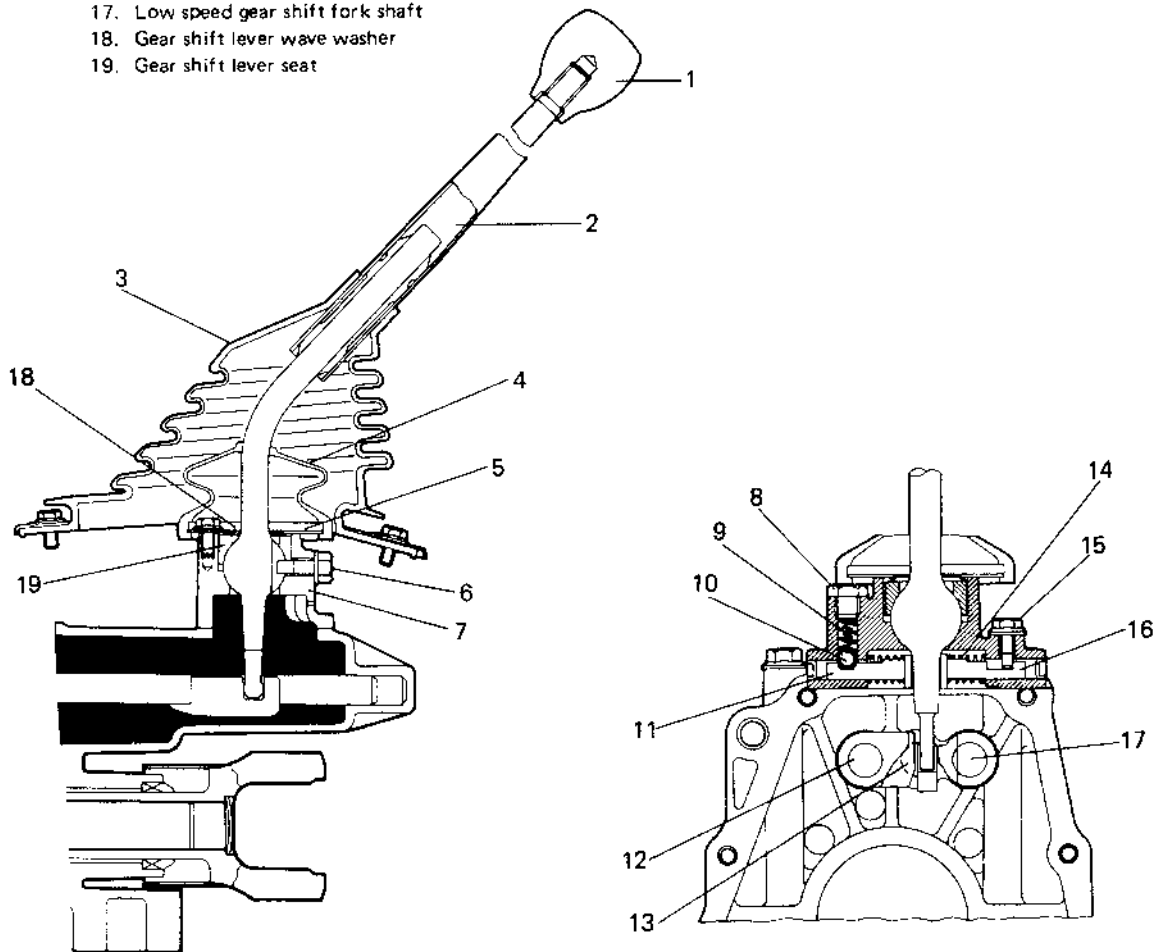


Fig. 12-1

## 12-2. REMOVAL

### Gear Shift Lever

- 1) Remove bolts tightening gear shift lever boot No. 2 and take boot off floor center tunnel.



Fig. 12-2

- 2) Take boot No. 1 off gear shift lever case and move it up (toward knob).
- 3) Remove 3 bolts tightening gear shift lever case cover.

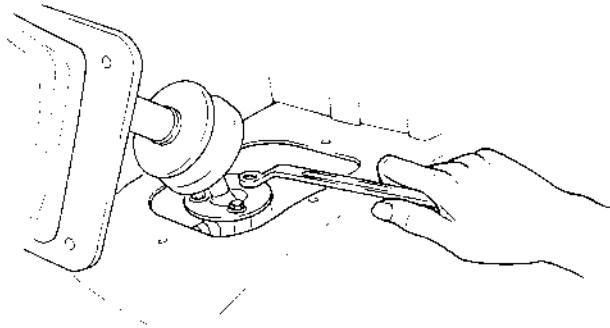


Fig. 12-3

- 4) Pull gear shift lever out of gear shift lever case.



Fig. 12-4

### Gear Shift Lever Select Guide Pins

- 1) After gear shift lever is removed according to foregoing steps 1) through 4), remove gear shift lever case by loosening its tightening bolts.



Fig. 12-5

- 2) Remove reverse select pin screw and take out spring and ball from case.
- 3) Remove low speed select pin bolt.
- 4) Compress reverse select guide pin ② against low speed select guide pin ① and take it out of gear shift lever case.

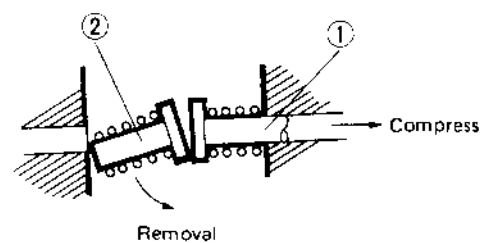


Fig. 12-6

### 12-3. INSPECTION OF COMPONENTS

#### Gear Shift Lever

Check lower end of gear shift lever where gear shift fork shaft contact, ① and ②, for wear and any kind of damage. Worn or damaged gear shift lever must be replaced with a new one.



Fig. 12-7

#### Reverse & Low Speed Select Guide Pins

Check both select guide pins where gear shift lever contacts, ③, for stepped wear. Replace worn select guide pin.

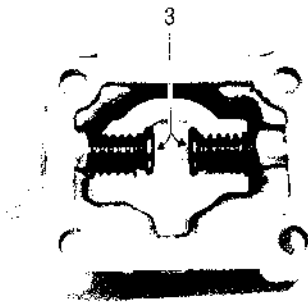


Fig. 12-8

Move shaft and check low speed select guide pin for smooth movement without rattle. If found defective, replace it and apply grease to pin.

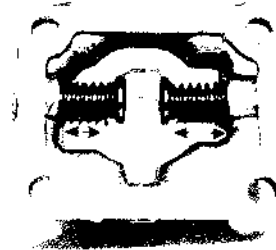


Fig. 12-9

#### Gear Shift Fork Shaft

Visually check each gear shift fork shaft (High, Low and Reverse) where gear shift lever contacts, ④, for wear. Worn shaft must be replaced.

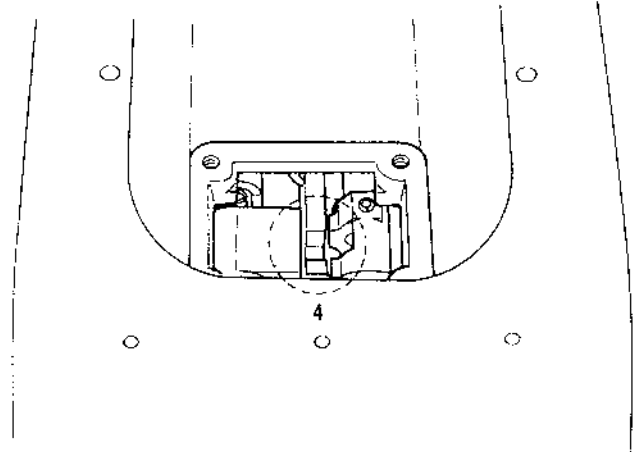


Fig. 12-10

## 12-4. INSTALLATION

Gear shift lever is installed by reversing removal procedure. Some important steps will be explained in detail.

### Reverse & Low Speed Guide Pins

Be sure to apply grease to select guide pins before installing them into gear shift lever case.

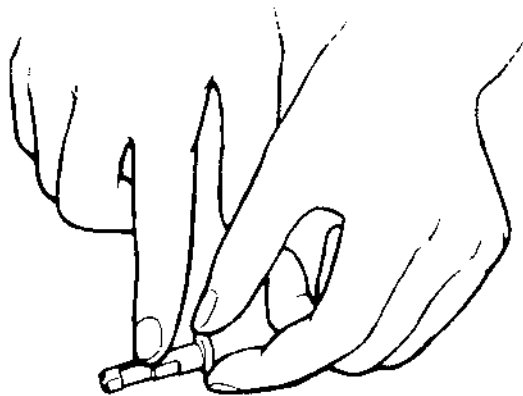


Fig. 12-11

When fitting low speed select guide pin into gear shift lever case, tighten locating bolt while pushing pin so that bolt goes in the groove provided in the pin. Then install reverse select guide pin in case and securely fit the locating ball in the groove provided in the pin.

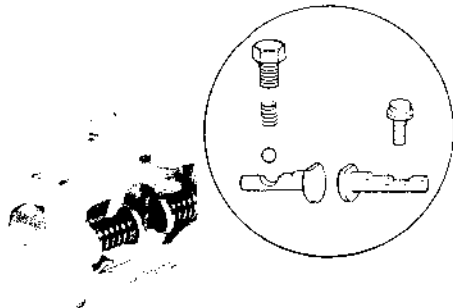


Fig. 12-12

### NOTICE:

After each guide pin is installed, make sure that flat surface ⑤ at the tip of pin faces upward (toward gear shift lever).

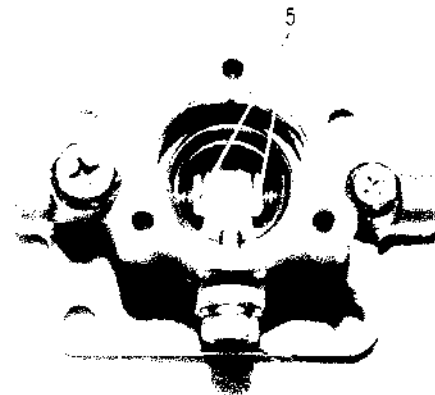


Fig. 12-13

### Gear Shift Lever Case

When installing lever case to transmission extension case, clean joint faces, and then apply sealant (SUZUKI BOND NO. 1215, 99000-31110) to joint faces.

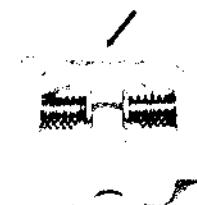


Fig. 12-14

### Gear Shift Control Lever Seat

Make sure to fit control lever seat ⑥ into gear shift lever case so that locating bolt ⑦ goes in the groove of control lever seat. And fit wave washer ⑧ with its projection surface directed upward.

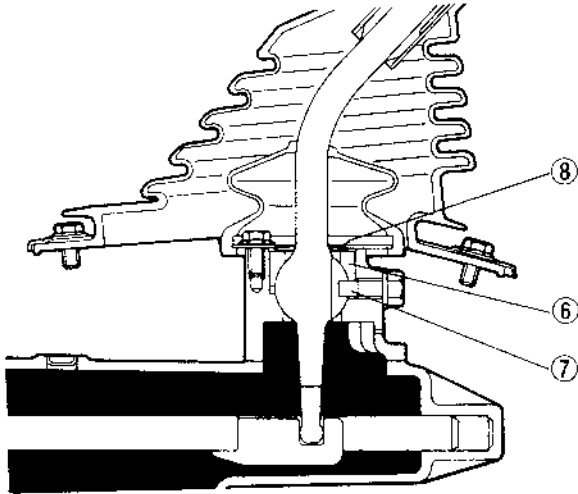


Fig. 12-15

### Tightening Torque & Greasing point

To be tightened to:	N·m	kg·m	lb·ft
① Lever case cover bolt	4 - 7	0.4 - 0.7	3.0 - 5.0
② Reverse select pin screw	25 - 35	2.5 - 3.5	18.5 - 25.0
③ Lever boot bolt	4 - 7	0.4 - 0.7	3.0 - 5.0
④ Lever locating bolt	14 - 20	1.4 - 2.0	10.5 - 14.0
⑤ Lever case bolt	18 - 28	1.8 - 2.8	13.5 - 20.0
⑥ Low speed select pin bolt	4 - 7	0.4 - 0.7	3.0 - 5.0

### Apply to

- Ⓐ : Between gear shift lever boot No. 1 and lever case cover
- Ⓑ : Between gear shift lever and lever seat
- Ⓒ : Between gear shift lever and lever case
- Ⓓ : Gear shift lever locating bolt

- \* Grease to be used for each greasing point is SUZUKI SUPER GREASE A(99000-25010).
- \* If gear shift lever locating bolt is removed from case, be sure to apply locking agent (THREAD LOCK CEMENT SUPER "1333B" 99000-32020) to bolt thread for reinstallation.

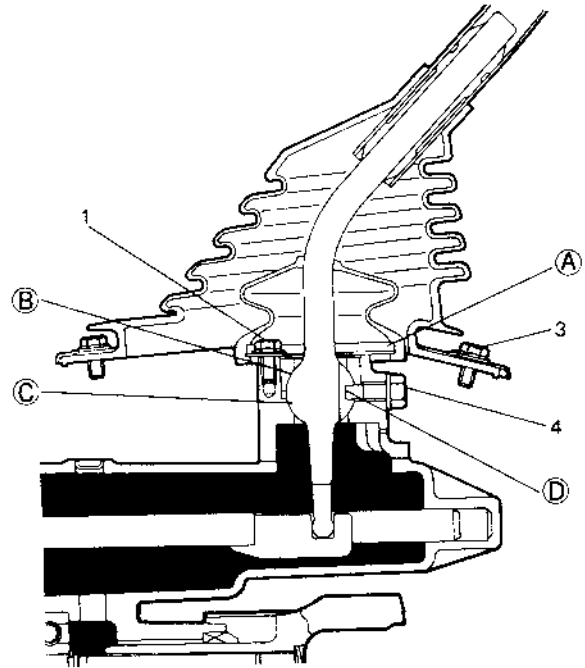
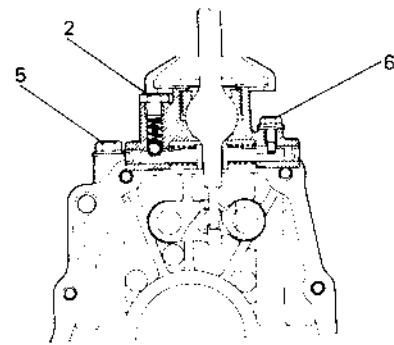


Fig. 12-16



## SECTION 13

# TRANSMISSION

## CONTENTS

13-1. GENERAL DESCRIPTION .....	13-1
13-2. TRANSMISSION GEAR RATIO .....	13-3
13-3. DISMOUNTING .....	13-4
13-4. DISASSEMBLY .....	13-5
13-5. INSPECTION OF COMPONENTS .....	13-12
13-6. IMPORTANT STEPS IN INSTALLATION .....	13-15
13-7. MAINTENANCE SERVICES .....	13-25
13-8. RECOMMENDED TORQUE SPECIFICATION .....	13-26

### 13-1. GENERAL DESCRIPTION

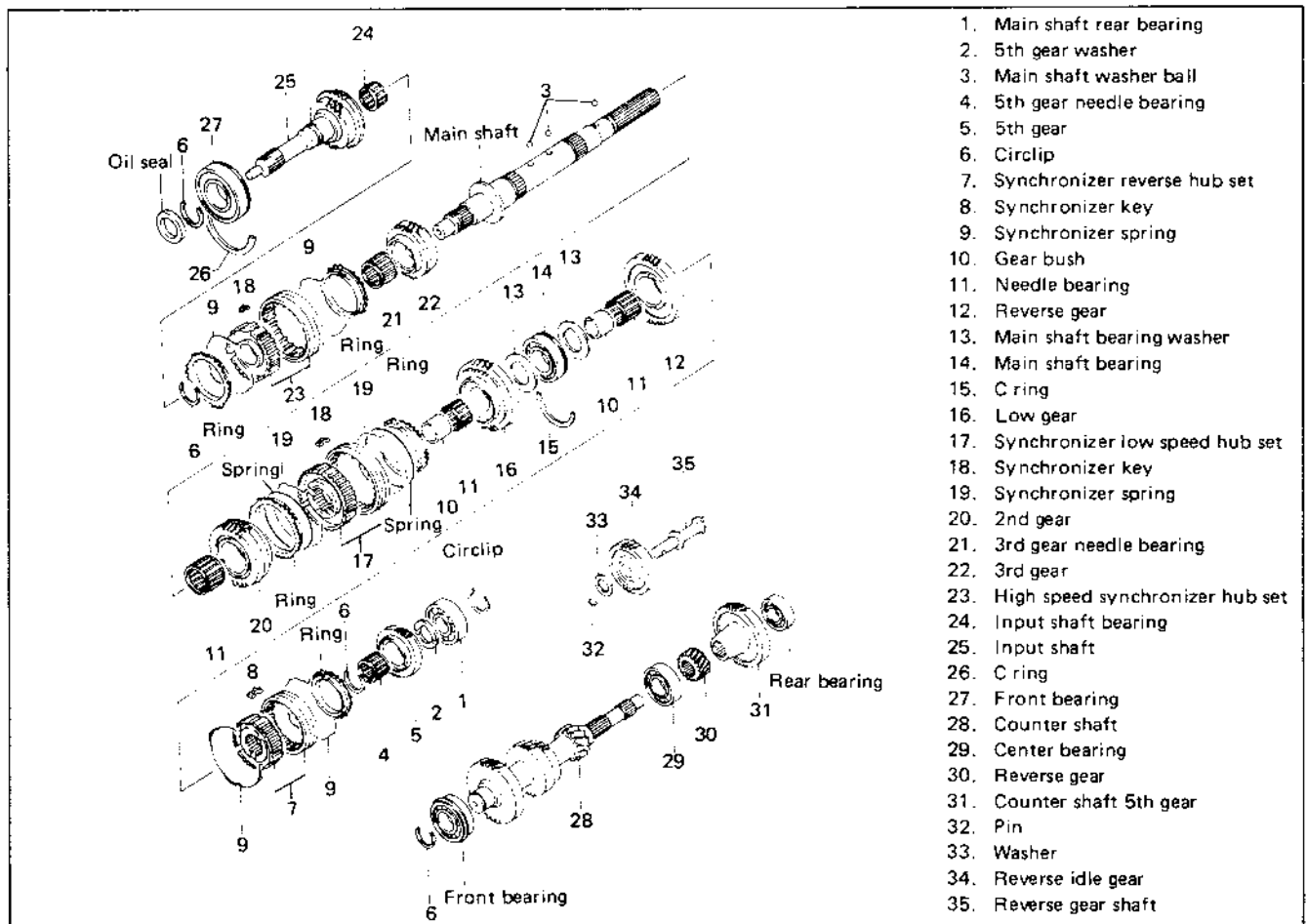


Fig. 13-1

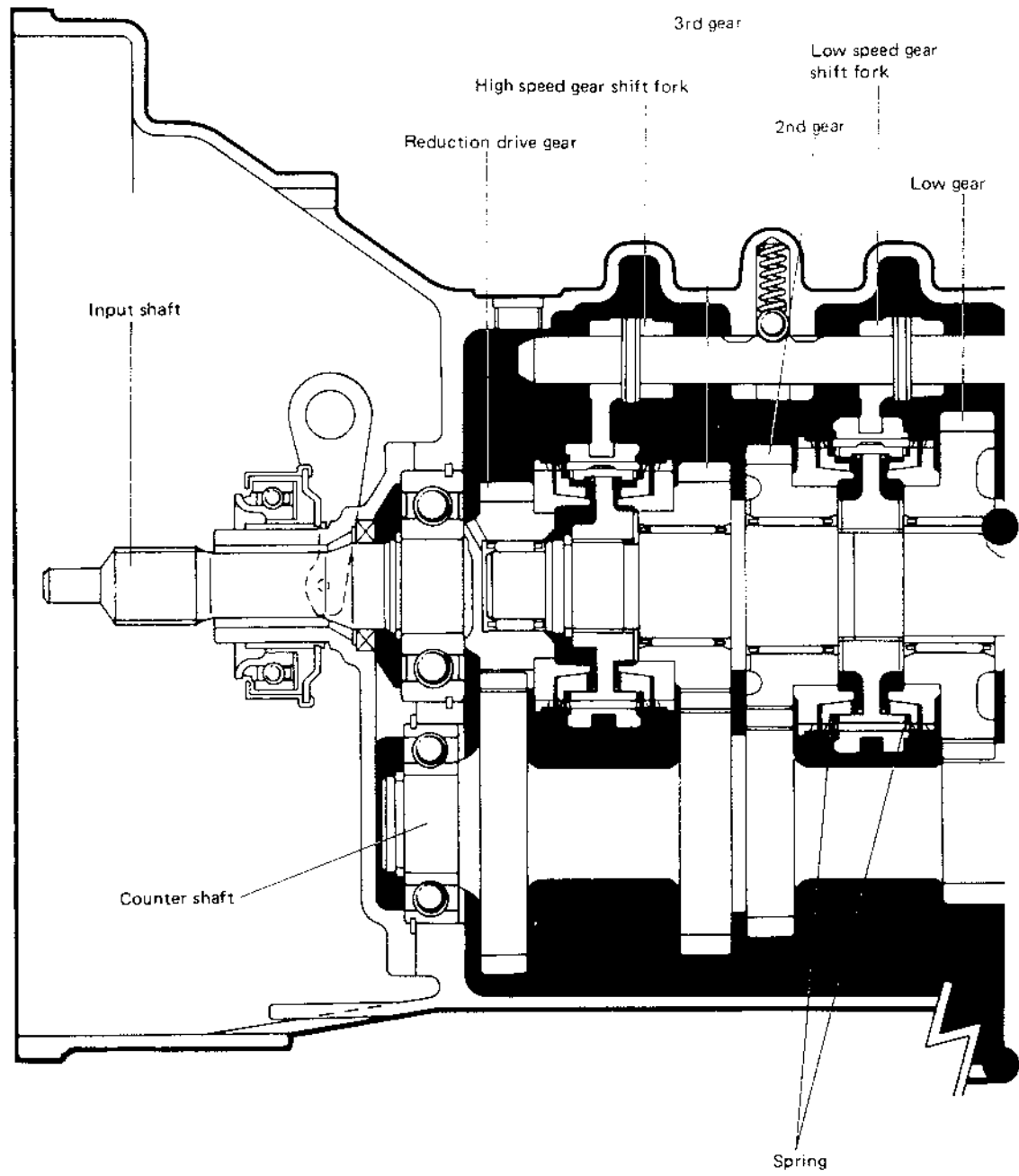
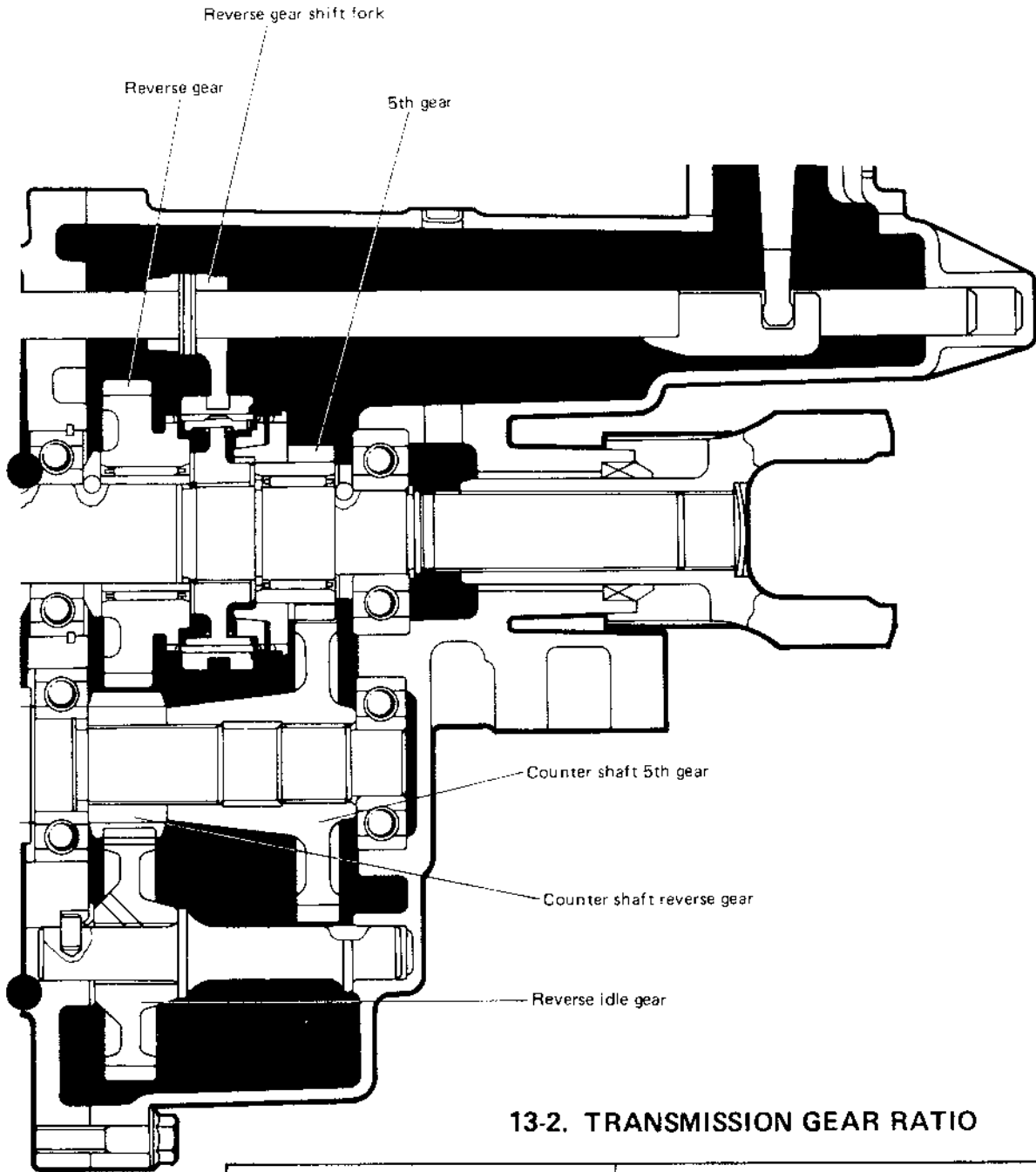


Fig. 13-2





### 13-2. TRANSMISSION GEAR RATIO

Primary gear ratio		35/23				—	35/23
Primary speed ratio		1.521				—	1.521
Shift position		Reverse	Low	Second	Third	Fourth	Fifth
Secondary ratios	Gear ratio	41/18	36/15	32/25	29/31	—	23/44
	Speed ratio	2.277	2.400	1.280	0.935	—	0.522
Overall speed reduction ratio		3.466	3.652	1.947	1.423	1.000	0.795

### 13-3. DISMOUNTING

#### In Passenger Compartment

- 1) Loosen 4 bolts fastening gear shift lever boot No. 2 and move boot upward.

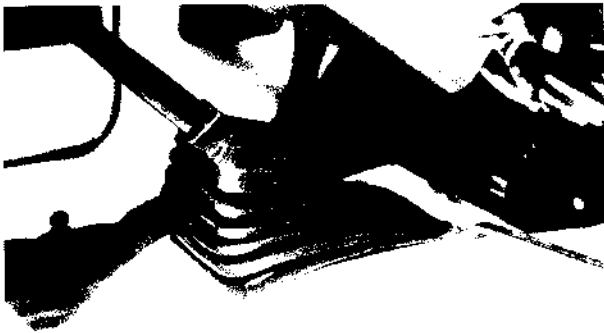


Fig. 13-2-1

- 2) Move gear shift boot No. 1 upward. Loosen gear shift lever case cover bolts (3 pcs) and draw gear shift lever out of lever case.

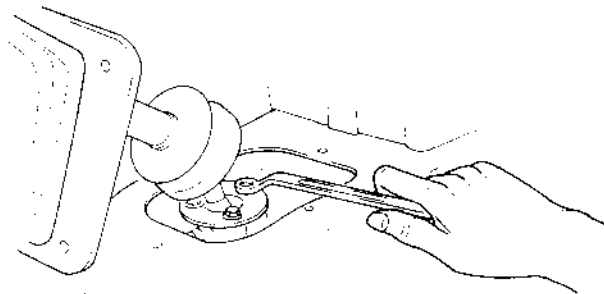


Fig. 13-2-2

#### In Engine Room

- 3) Disconnect negative (-) and positive (+) cords from battery terminals.
- 4) Disconnect back light and fifth switch lead wires at coupler respectively.
- 5) Disconnect Black/Yellow lead wire and positive (+) cord from starter motor.
- 6) Remove starter motor from transmission case and fuel hoses clamp from transmission case.

#### Under Engine

- 7) Remove drain plug to drain oil in transmission.
- 8) Disconnect clutch wire from clutch release lever.
- 9) Remove propeller shaft No. 1 (from transmission to transfer).
- 10) Remove propeller shaft No. 2 (from transfer to front differential).
- 11) Remove clutch housing lower plate from transmission case.



Fig. 13-2-3

- 12) Remove bolts and nuts fastening engine cylinder block and transmission case.
- 13) Remove pipe ① as shown in Fig. 13-2-4.



Fig. 13-2-4

- 14) Remove exhaust center pipe.
- 15) Remove transmission rear mounting bracket from chassis and transmission case.

#### NOTICE:

Before starting to remove transmission, check around once again to be sure that there is no connection left undone.

- 16) Take down transmission.

## 13-4. DISASSEMBLY

### Replacing Clutch Release Shaft Bush

- 1) Remove clutch release bearing from input shaft bearing retainer.

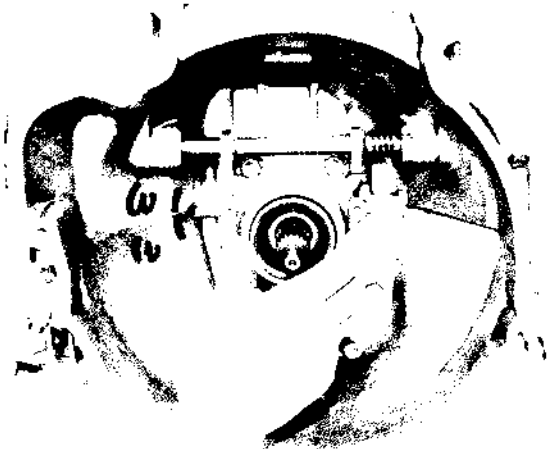


Fig. 13-3

- 2) Remove a part of spring from clutch release shaft lever.

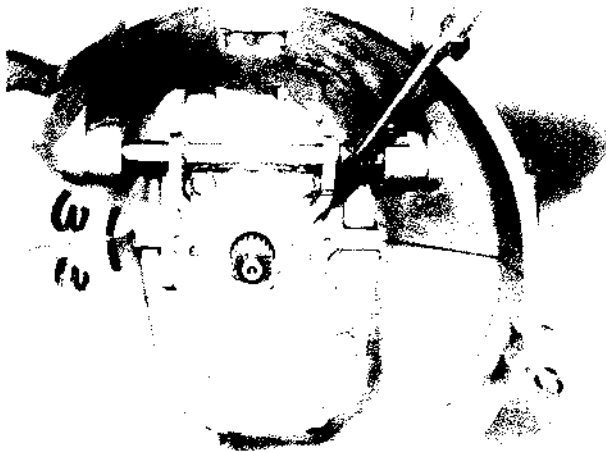


Fig. 13-3-1

- 3) Remove clutch release shaft spring from shaft. With special tool (A) applied in such a position as shown in Fig. 13-3-2, tap the end of special tool to take out bush and cap. Clutch release bush remover (A) (09925-48210)



Fig. 13-3-2

- 4) Take out the other bush, too.

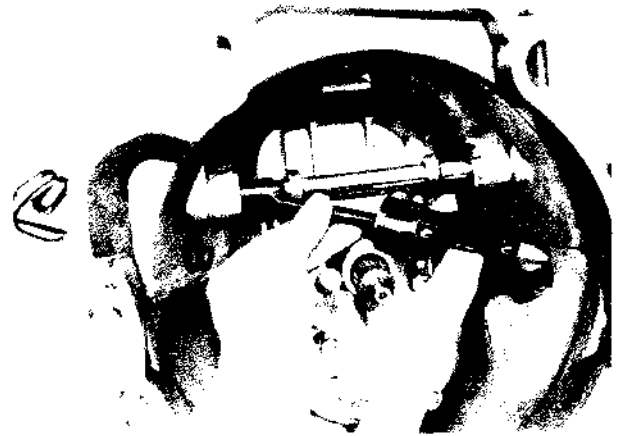


Fig. 13-3-3

- 5) Precautions on bush reinstallation:

- Make sure to apply grease to inside of bushes.
- Drive in bushes to the same level as inside surface of transmission case. Install cap and oil seal securely after greasing oil seal lip.



Fig. 13-3-4

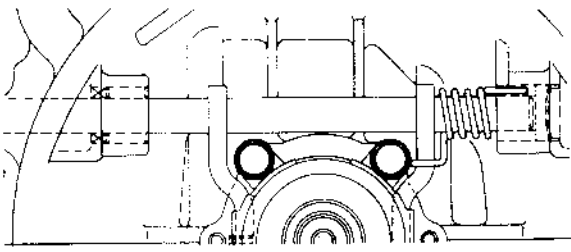


Fig. 13-3-5

- After installing seal, caulk transmission case against seal at two points.

**Separating Upper Case from Lower Case**

- 1) Remove clutch release bearing from transmission input shaft.

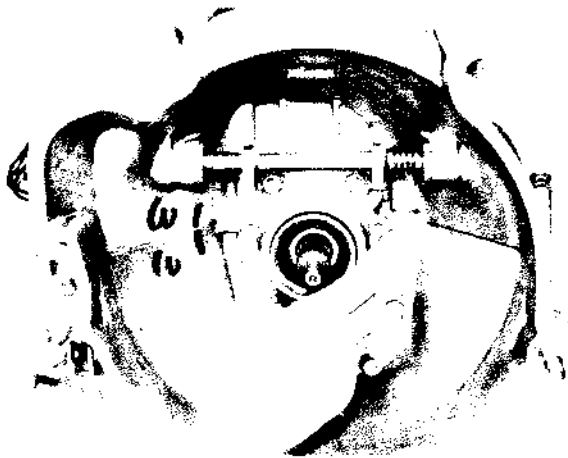


Fig. 13-4

- 2) Remove input shaft bearing retainer bolts and pull out retainer by using 3 conventional 6 mm bolts.

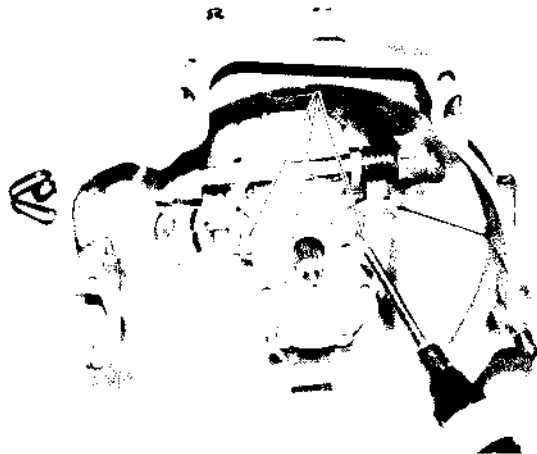


Fig. 13-4-1

- 3) Remove bolts securing extension case to transmission case and reverse shift rim bolt ①. Then take off extension case.



Fig. 13-4-2

- 4) Remove bolts fastening upper and lower cases together, separate the two, and take out main shaft assembly. A steel bar, similar in shape to screwdriver, may have to be used to pry two cases apart, as shown. In such a case, do not stick bar too far into between two mating faces, or faces may become damaged.

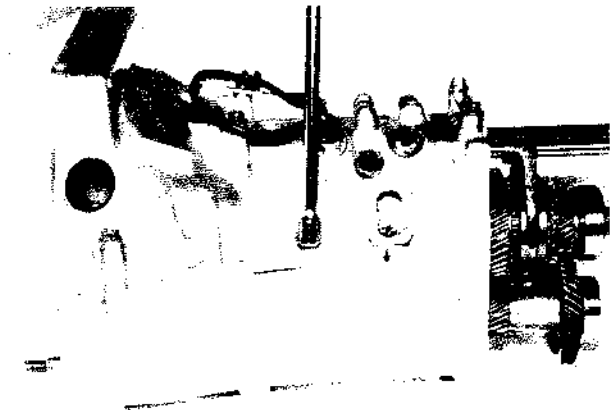


Fig. 13-5



Fig. 13-5-1

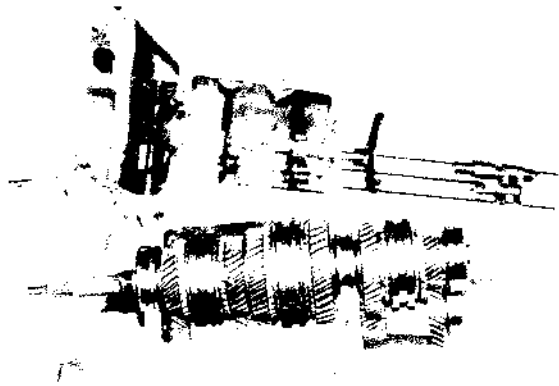


Fig. 13-5-2

3) Remove countershaft 5th gear and countershaft reverse gear.

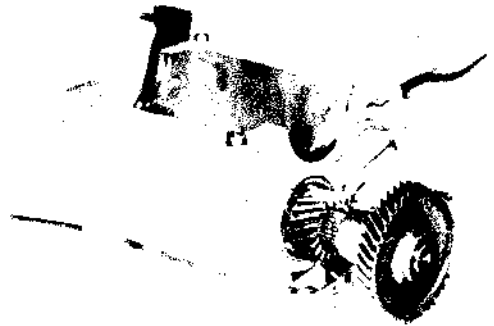


Fig. 13-8

### Removing Countershaft

1) Remove reverse gear shaft with gear.



Fig. 13-6

4) Remove circlip from countershaft. Push out countershaft to extension case side by using hydraulic press, remove bearing, and take countershaft assembly out of case.

Bearing puller (B) (09913-65135)

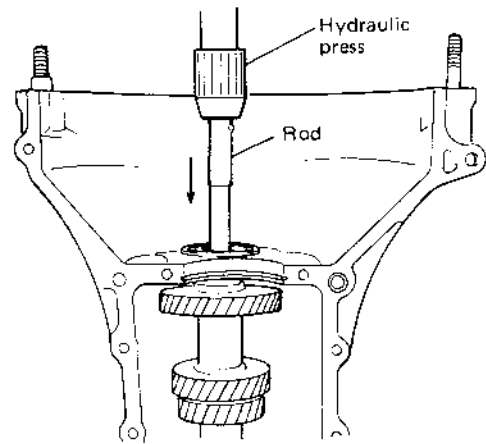


Fig. 13-9

2) Remove countershaft rear bearing.

Bearing puller (B) (09913-65135)

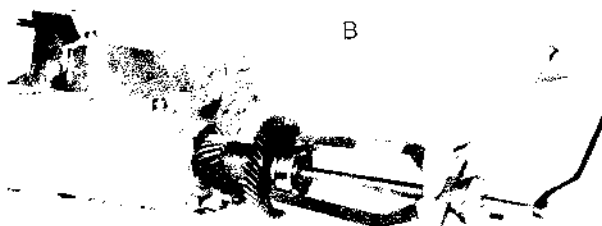


Fig. 13-7

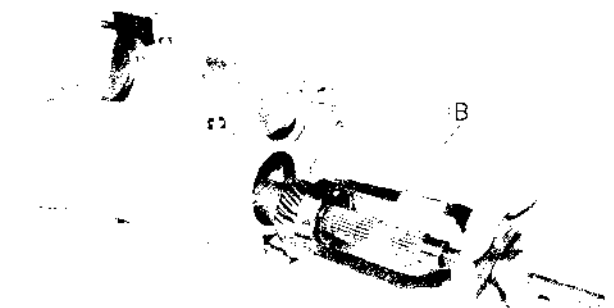


Fig. 13-9-1

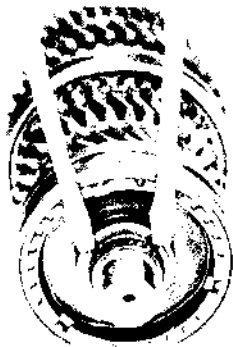
### Removing Main Shaft and Input Shaft

- 1) Take out input shaft by hand, taking care not to let high-speed synchronizer ring fall off.



*Fig. 13-10*

- 2) Remove circlip retaining hub of high-speed synchronizer sleeve, and slide off sleeve hub, third driven gear and needle bearing from main shaft.



*Fig. 13-11*

- 3) Remove circlip retaining rear bearing on main shaft. Remove main shaft bearing.



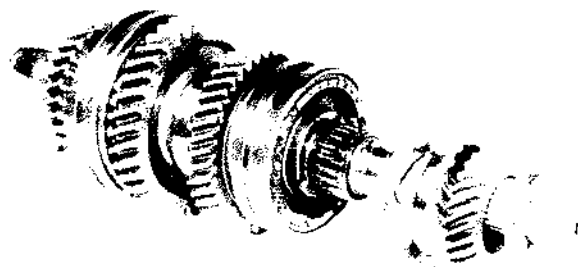
*Fig. 13-12*

Bearing puller (B) (09913-65135)



*Fig. 13-13*

- 4) From main shaft, take off 5th gear washer, ball, 5th gear, 5th speed synchronizer ring and 5th gear needle bearing.



*Fig. 13-14*

5) Remove circlip retaining the reverse synchronizer hub on main shaft.

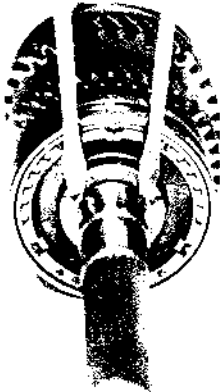


Fig. 13-15

6) Remove reverse synchronizer hub, reverse gear and reverse gear needle bearing.

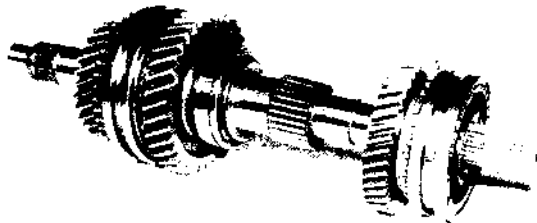


Fig. 13-16

7) Remove bearing washer and reverse gear bush on main shaft by using hydraulic press.

**NOTICE:**

During this removal, watch out for a ball which may fall off. It must not be lost. Also, ball bearing should not be removed together with above washer and bush.

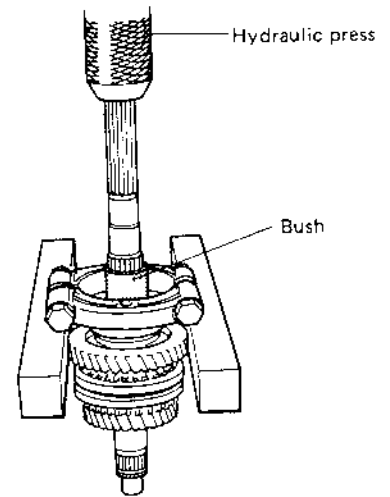


Fig. 13-17

8) Remove ball and main shaft (center) bearing by using hydraulic press.

**NOTICE:**

In the state as shown below, there is a ball in washer which is located under bearing. Be sure to prevent it from falling off and getting lost.

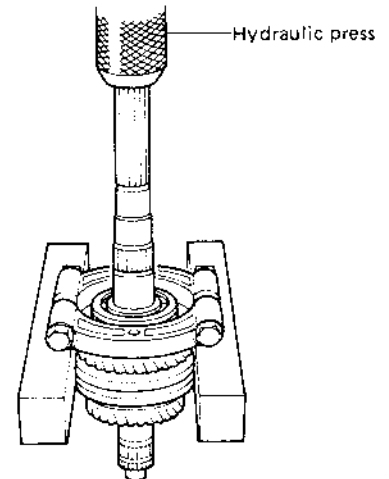


Fig. 13-18

9) Remove low gear, needle bearing, synchronizer ring and spring on main shaft.



Fig. 13-19

10) Remove low gear bush, low speed synchronizer hub, ring, spring, 2nd gear and 2nd gear bearing by using hydraulic press.

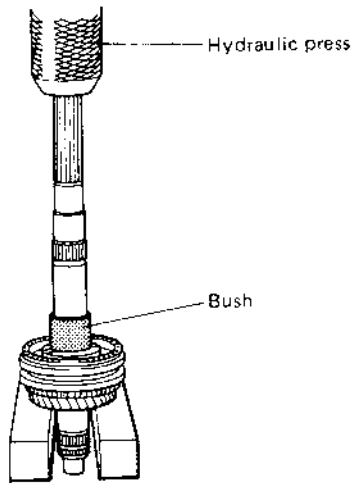


Fig. 13-20

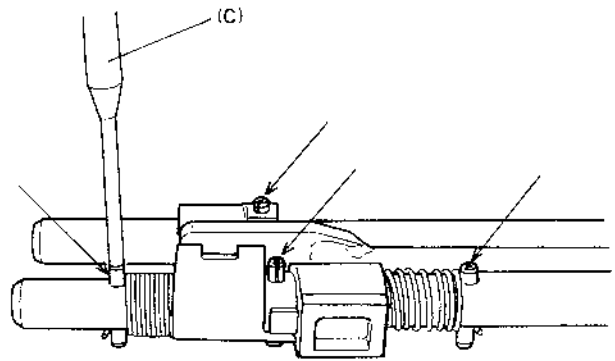
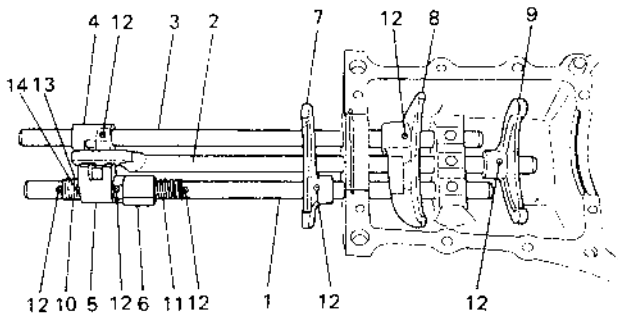


Fig. 13-22

[Gear shift fork and shaft]

Before starting removal, make sure that all shift fork shafts in place are in neutral position and remove each fork and shaft according to following 1), 2) and 3).

### Removing Shift Yokes, Forks and Shafts



- |                                |                                   |
|--------------------------------|-----------------------------------|
| 1. Reverse gear shift shaft    | 8. Low speed gear shift fork      |
| 2. High speed gear shift shaft | 9. High speed gear shift fork     |
| 3. Low speed gear shift shaft  | 10. 5th select return spring      |
| 4. Low speed gear shift yoke   | 11. Reverse gear shift rim spring |
| 5. 5th gear shift yoke         | 12. Shift yoke pin                |
| 6. Reverse gear shift rim yoke | 13. E-ring                        |
| 7. Reverse gear shift fork     | 14. Washer                        |

Fig. 13-21

[Gear shift yoke]

For shift yoke removal, drive out yoke pin with spring pin remover (special tool) first, and then remove yoke.

Spring pin remover (C) (09922-85811)

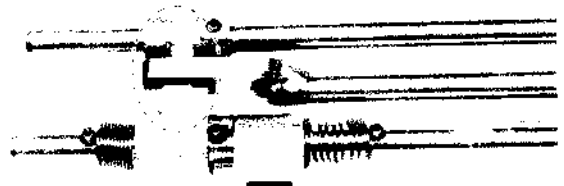


Fig. 13-23 Neutral position

1) Pull out reverse gear shift shaft. As this shaft comes out, locating ball and spring will jump out of hole; do not let them fly away.



Fig. 13-24



2) Using the same special tool (C), mentioned above, drive out yoke pin on high speed gear shift fork, and pull out shift shaft. As in above case, be careful not to let locating ball, interlock ball and spring fly away.

**CAUTION:**

When removing yoke pin, be sure not to drive it out so far as to contact case. Or it will cause damage to case.

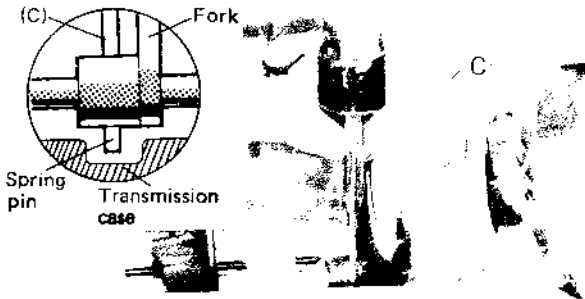


Fig. 13-25



Fig. 13-26

3) Drive yoke pin out of low speed gear shift fork as in above step 2) and pull out fork shaft and fork.



Fig. 13-27



Fig. 13-28

## 13-5. INSPECTION OF COMPONENTS

### Gears

Check each part for wear, damage or discoloration. Replace if found defective.



Fig. 13-29

### Synchronizer Hubs, Sleeves and Keys

Check each part for wear or damage. Replace if found defective.



Fig. 13-30

### Shift Forks and Sleeves

Check contact surfaces for wear or damage. Measure clearance between fork and sleeve.

Maximum clearance	1.0 mm (0.039 in)
-------------------	-------------------



Fig. 13-31

### Main Shaft

Check each part of shaft for wear, discoloration or damage. Replace shaft if any part is found defective.

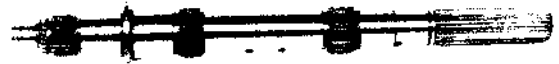


Fig. 13-32

### Bearings and Bushes

Check each part for wear, damage or discoloration. With ball bearing, check to ensure that it rotates smoothly and it does not make noise. Replace if found defective.



Fig. 13-33

### Input Shaft

Referring to Fig. 13-34, inspect cone ① and toothed ring ② for wear and damage.

Inspect gear teeth ③ and splines ④ for wear and damage.

If any part of input shaft inspected as above is found excessively worn or badly damaged, replace shaft.

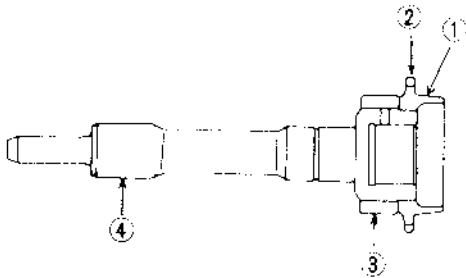


Fig. 13-34

### Combination of Gear and Synchronizer Ring

Fit ring to cone of each gear, and measure clearance between the two at peripheral teeth, as shown in Fig. 13-35. If clearance exceeds service limit, replacement is necessary.

Clearance between gear and ring		
	Standard	Service limit
Low and High speed	1.0 – 1.4 mm (0.039 – 0.055 in.)	0.5 mm (0.019 in.)
5th speed	1.2 – 1.6 mm (0.047 – 0.063 in.)	0.5 mm (0.019 in.)



Fig. 13-35

Inspect external cone (of gear) and internal cone (of ring) for abnormal wear. Be sure that contact patterns on these surfaces indicate uniform full-face contact, and that surfaces are free from any wavy wear. A badly worn member must be replaced.

Proper synchronizing action on gear shifting can be expected only when ring-to-gear clearance (Fig. 13-35) and condition of cone surfaces, among other things, are satisfactory.



Fig. 13-36 ⑤ Checking contacting surface

### Chamfered Tooth Ends of Ring (External Teeth) and Sleeve (Internal Teeth)

Synchronizer ring and hub have three slots each, in which keys are carried as backed by expanding springs, so that the hub and its two rings, one on each end, are capable of running together. Since the sleeve is engaged by its internal teeth with the hub as if the two were splined together, the sleeve, too, runs with the hub and rings.

In meshing action, the sleeve is pushed (by the shifter fork) to one side, so that it slides axially on the hub, pushing the ring toward the cone surface of the gear. This push is transmitted by three keys, which are lightly gripped by the sleeve.

By friction between the gear cone and ring cone (internal), the ring begins to rotate but is copposed by the hub because of keys. In other words, the ring is at this time twisted, while the sleeve is advancing further to push the ring fully against the gear cone. Since the ring is unable to slide along any further, the sleeve lets go off the keys and rides over to the ring. At this moment, the initial contact between the chamfered ends of teeth of the ring and those of internal teeth of the sleeve occurs. This contact is such that the internal teeth of the sleeve align themselves to those of the ring. When the sleeve advances and slides into the ring, the ring will be rotating nearly with the speed of the gear, so that the sleeve is enabled smoothly to slide over into the clutch teeth of the gear.

The initial contactor mesh between sleeve and ring is determined by the widths of key and slot or, in other words, the key clearance in the slot, and is prescribed to extend at least a third (1/3) of the chamfer.

With the synchronizer properly assembled on the shaft, push in and twist each synchronizer to see if one-third mesh occurs or not; if not, it means that the overall wear (which is the sum of wears of slots, keys and chamfered tooth ends) is excessive and, in such a case, the entire synchronizer assembly must be replaced.

Mesh of chamfered tooth ends of synchronizer ring and sleeve	Contact extending about 1/3 of chamfered face from apex
--	---

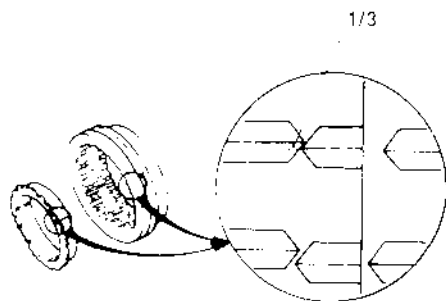


Fig. 13-37

### Synchronizer Rings

Inspect each synchronizer ring for wear of its key slots by measuring width of each slot. If width reading exceeds limit, replace ring.

Key slot width of synchronizer ring	Standard	Service limit
	10.1 mm (0.397 in.)	10.4 mm (0.409 in.)



Fig. 13-38

### Fork Shaft Locating Springs

If "gears slipping out of mesh" has been complained, check these springs for strength by measuring their free length, and replace them if their free lengths are less than service limit.

Spring No.	Standard	Service limit
Free length	25.5 mm (1.004 in.)	21.0 mm (0.826 in.)

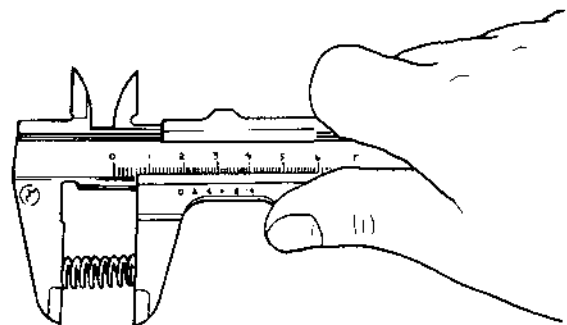


Fig. 13-39

### Gear Shift Shafts

Check the part of shaft as indicated in below figure for uneven wear. Replace shaft if uneven wear is noted.

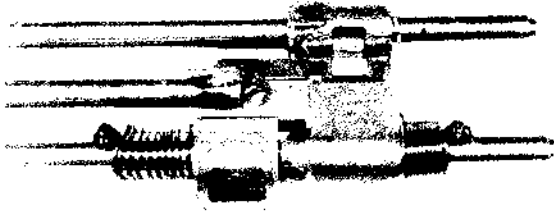


Fig. 13-40

### Extension Case Bush

Check bush press-fitted in extension case for wear by measuring radial clearance between bush bore and sliding yoke. If sliding yoke rattles in bush because of advanced wear it will cause propeller shaft to rattle. For this reason, an extension case found to allow its sliding yoke to rattle in excess of service limit must be replaced; replacement of bush alone is not permissible.

Rattle of sliding yoke in extension case bush	Standard 0.025 – 0.089 mm (0.0010 – 0.0035 in.)	Service limit 0.2 mm (0.0078 in.)

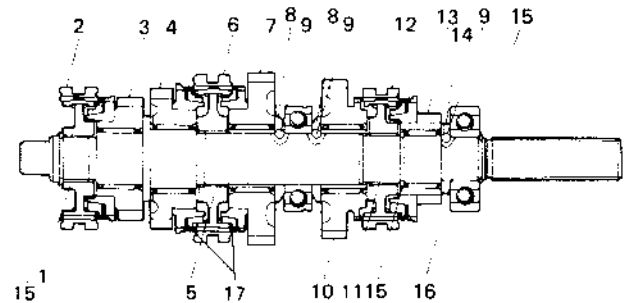
## 13-6. IMPORTANT STEPS IN INSTALLATION

### NOTICE:

- Before installation, wash each part and apply specified gear oil to sliding faces of bearing and gear.
- Use new circlips on shaft for reinstallation. Don't reuse used circlips.
- Tighten each fastening bolt and nut according to specified torque data listed on the last page of this section.

### Main Shaft and Input Shaft

Install each parts by reversing respective removal procedures. Be careful for installing direction of each washer, gear, synchronizer hub and sleeve. Refer to figure below. Make sure to install each ball on main shaft.



- |                                   |                                 |
|-----------------------------------|---------------------------------|
| 1. High speed synchronizer hub    | 8. Washer                       |
| 2. High speed synchronizer sleeve | 9. Ball                         |
| 3. 3rd gear                       | 10. Reverse gear                |
| 4. 2nd gear                       | 11. Reverse synchronizer hub    |
| 5. Low speed synchronizer hub     | 12. Reverse synchronizer sleeve |
| 6. Low speed synchronizer sleeve  | 13. 5th gear                    |
| 7. Low gear                       | 14. 5th gear washer             |
|                                   | 15. Circlip                     |
|                                   | 16. Main shaft                  |
|                                   | 17. Spring                      |

Fig. 13-41

1) Install 2nd gear bearing, 2nd gear, spring, synchronizer ring and low speed synchronizer hub/sleeve onto main shaft, using care for installing direction of synchronizer sleeve.

After putting on each synchronizer, be sure that 3 keys mounted on hub fit snugly into slots cut in ring.

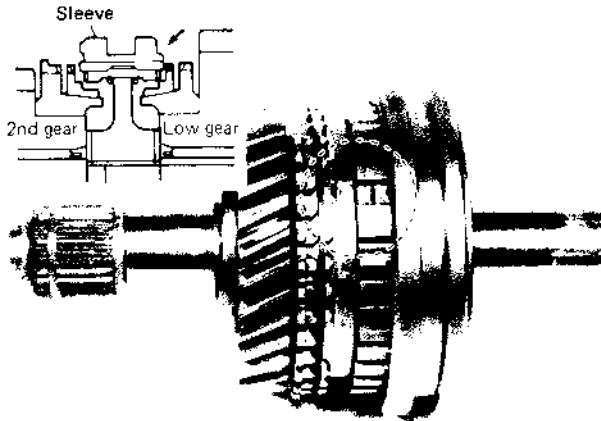


Fig. 13-42

Then using hydraulic press, press-fit low gear bush. 2 bushes on main shaft are the same.  
Bearing installer (D) (09925-18010)



Fig. 13-43

2) Install low gear needle bearing, spring, synchronizer ring, low gear, ball and washer onto main shaft.

Fit ball into hole in shaft and install washer so that its slot ① comes over ball ③.

To direct washer correctly, bring its circumference chamfered side ② to main shaft center bearing.

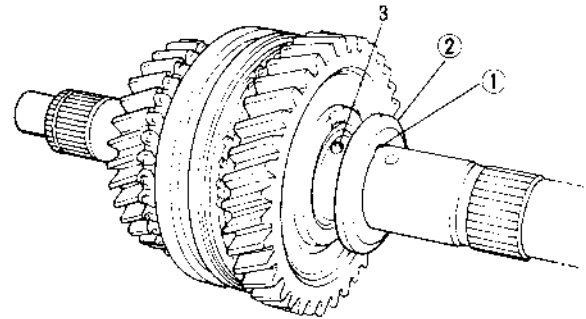


Fig. 13-44

3) Press-fit center bearing with bearing installer (special tool) using care for its installing direction.

Bearing installer (D) (09925-18010)

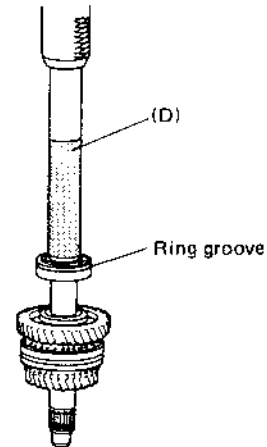


Fig. 13-45

4) Install ball and washer.

As figure shows, install washer so that its circumference chamfered side faces center bearing ① and its slot ② comes over ball ③.

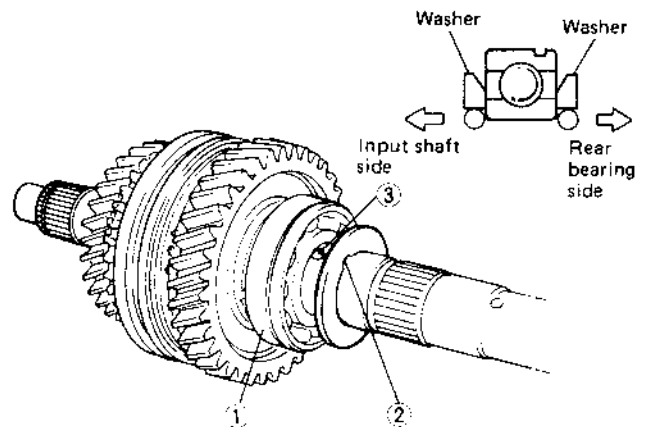


Fig. 13-46

- 5) Press-fit reverse gear bush, preventing ball installed in step 4) from coming off.  
 Bearing installer (D) (09925-18010)

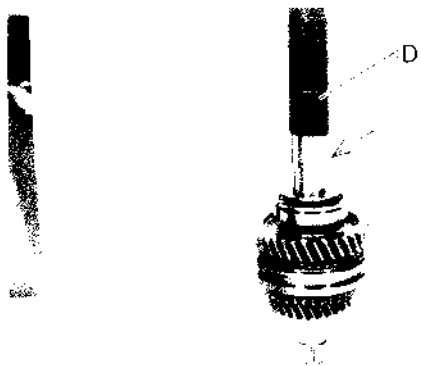


Fig. 13-47

- 6) Install reverse gear bearing, reverse gear and reverse synchronizer hub/sleeve. For proper direction, make sure to install hub so that the side whose inside boss ① is smaller in diameter and longer is directed to main shaft rear bearing, and sleeve so that the side whose inside is stepped ② is also directed to main shaft rear bearing.

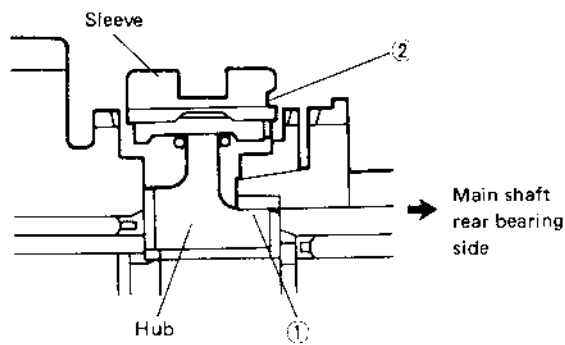


Fig. 13-48

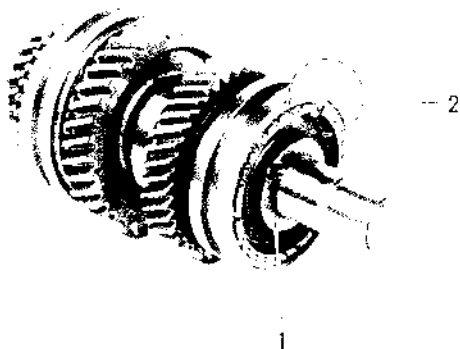


Fig. 13-49

- 7) Fit reverse hub circlip into groove in main shaft.

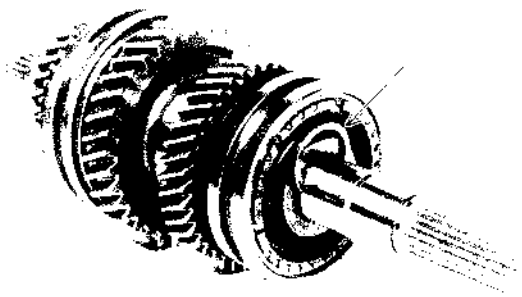


Fig. 13-50

- 8) Install 5th gear bearing, 5th gear synchronizer ring and 5th gear. Then install ball and washer, making oil groove of washer face 5th gear.

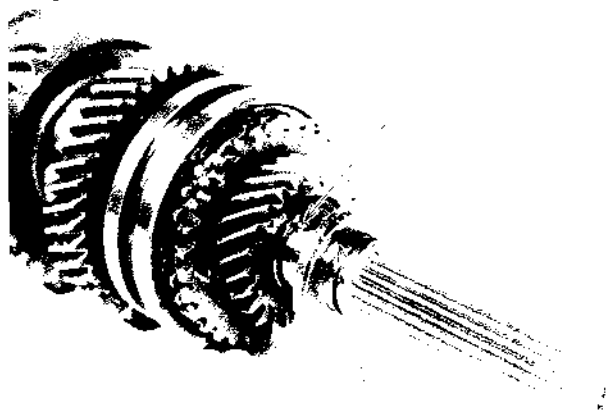


Fig. 13-51

- 9) Press-fit main shaft rear bearing and fit circlip into groove in main shaft.  
 Bearing installer (D) (09925-18010)



Fig. 13-52

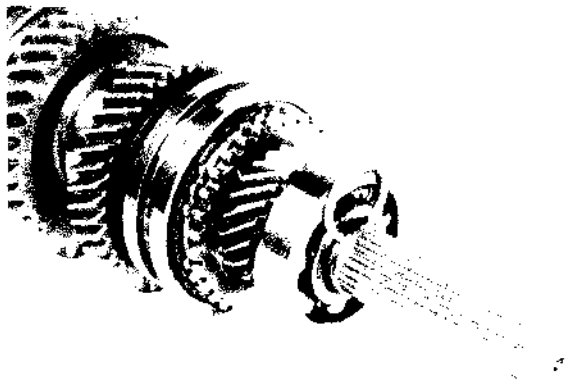


Fig. 13-53

10) Install 3rd gear bearing, 3rd gear, high speed synchronizer ring and hub/sleeve. When installing hub, direct the side with larger outer diameter boss to 3rd gear side. Then fit circlip into groove in main shaft.

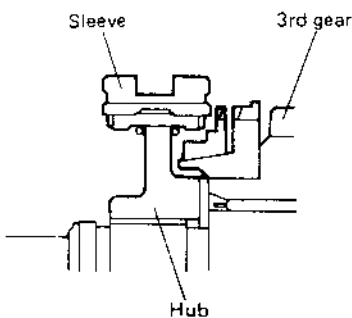


Fig. 13-54

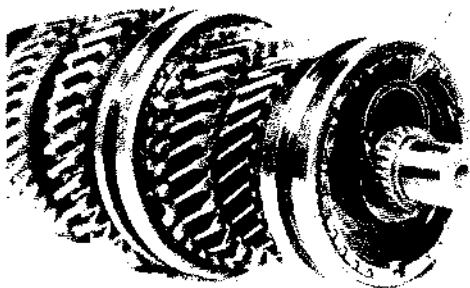


Fig. 13-55

11) Install synchronizer ring, needle bearing and input shaft.



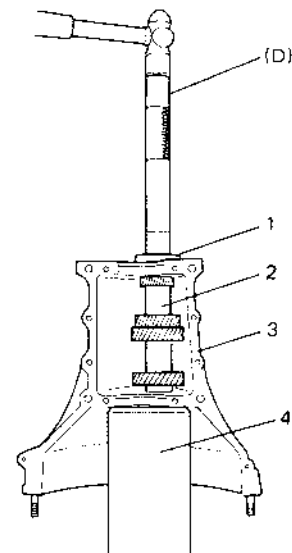
Fig. 13-56

### Counter Shaft and Reverse Idle Gear

1) Drive counter shaft front bearing into lower case. Then using plastic hammer, drive counter shaft into front bearing a little.

In the above state, using bearing installer (special tool), drive center bearing onto counter shaft and into lower case.

Bearing installer (D) (09925-18010)



1. Center bearing  
2. Counter shaft

3. Transmission lower case  
4. Wood stand

Fig. 13-57



2) Fit counter shaft front circlip into groove in shaft.



Fig. 13-58

3) Install counter shaft reverse gear and 5th gear onto counter shaft. And then drive counter shaft rear bearing onto it.



Fig. 13-59

4) Install idle gear and washer onto reverse gear shaft and pin into it. Install above as assembled into lower case with pin ① and washer tongue ② aligned as shown below.

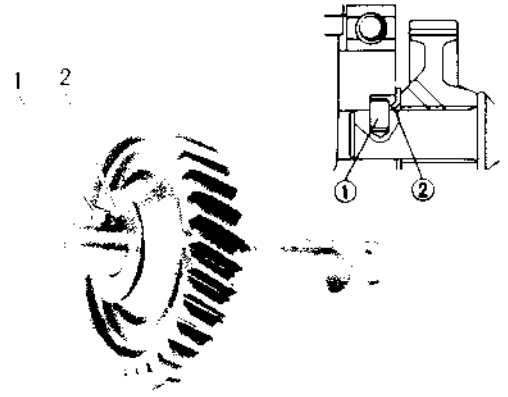


Fig. 13-60



Fig. 13-61

### Shifter Forks, Shafts and Yokes [Forks and Shafts]

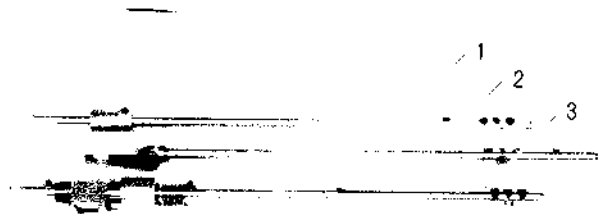


Fig. 13-62

- ① Low speed gear shift shaft
- ② High speed gear shift shaft
- ③ Reverse gear shift shaft

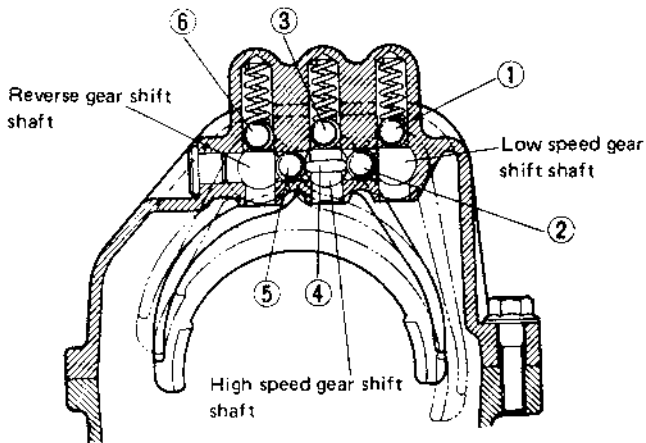


**Fig. 13-63** ④ High and reverse gear shift fork  
⑤ Low speed gear shift fork

**NOTICE:**

Gear shift forks used for high and reverse are the same.

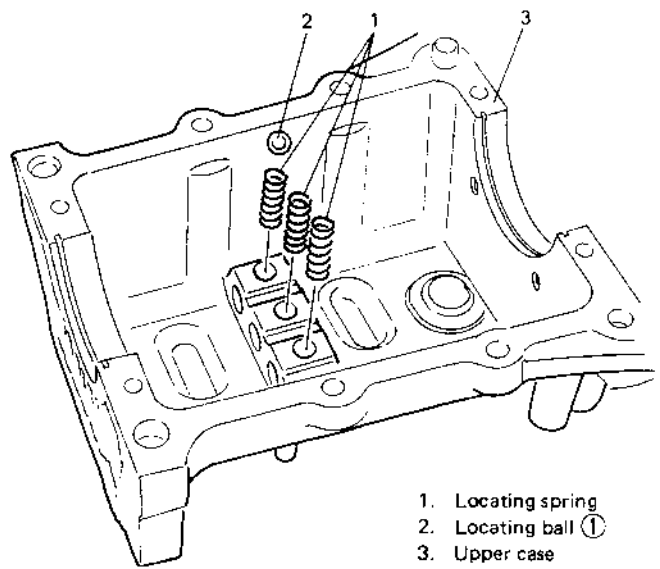
Note that 3 shift shafts individually have a locating ball and locating spring, and that 2 interlock balls and an interlock roller are used between shafts as shown in Fig. 13-64.



**Fig. 13-64**

Install low, high and reverse shafts in that order.

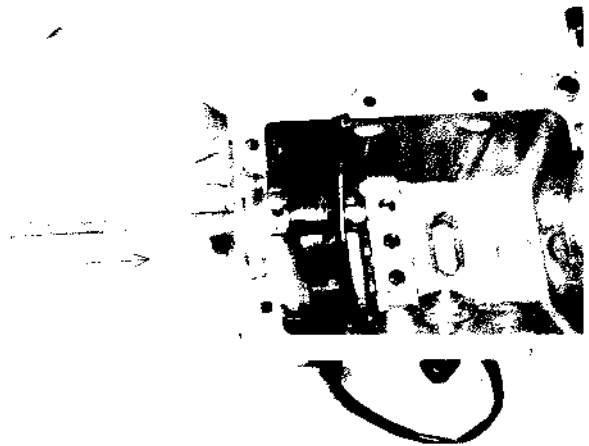
- 1) Install 3 locating springs into 3 holes in upper case. Fit locating ball (① in Fig. 13-64) on top of locating spring in hole.



1. Locating spring  
2. Locating ball ①  
3. Upper case

**Fig. 13-65**

- 2) Insert low speed gear shift shaft into upper case and low speed shift fork in the direction as shown in Fig. 13-66.



**Fig. 13-66**

- 3) As shown below, push down low speed gear shift shaft locating ball to pass shaft over it and keep inserting shaft until locating ball fits in center slot of 3 continuous slots in shaft.  
Drive shift yoke pin into fork and shaft.

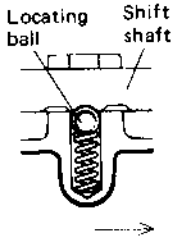


Fig. 13-67

4) Install interlock ball ( ② in Fig. 13-64) and locating ball ( ③ in Fig. 13-64) in upper case. After installing interlock roller ( ④ in Fig. 13-64) in high speed gear shift shaft and insert shaft into upper case as described in 2) and 3).

Fork should be installed in such direction as shown in Fig. 13-68. Then drive shift yoke pin until it becomes flush with outer surface of fork.



Fig. 13-68

5) Install interlock ball ( ⑤ in Fig. 13-64) and locating ball ( ⑥ in Fig. 13-64) into upper case. Then insert reverse gear shift shaft into upper case as described in 2) and 3).

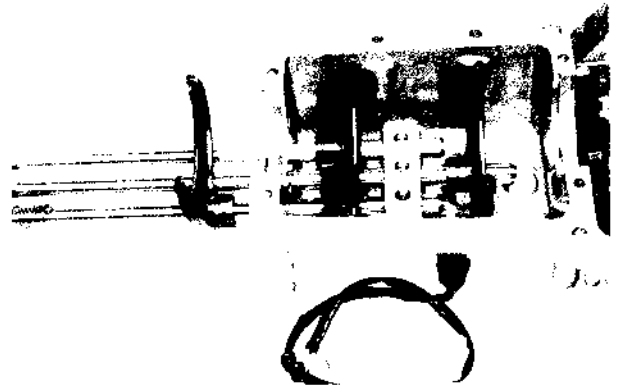


Fig. 13-69

[Yokes]

1) Install low speed gear shift yoke as shown below, using care for its direction.

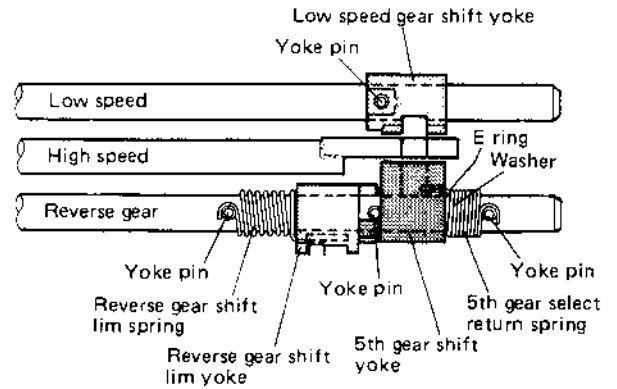


Fig. 13-70

2) Install reverse gear shift yoke and 5th gear shift yoke as shown below. Use care for installing direction of each part.

Between 2 springs, shorter one is 5th select return spring.

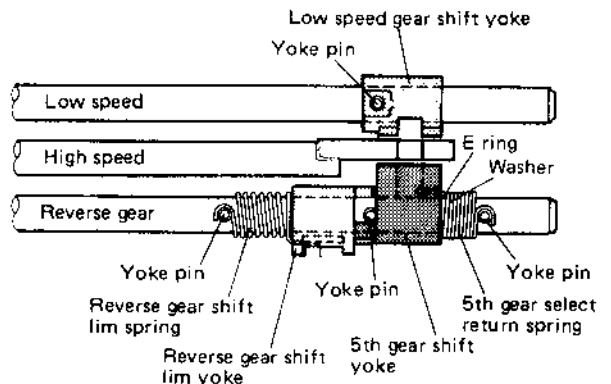


Fig. 13-71

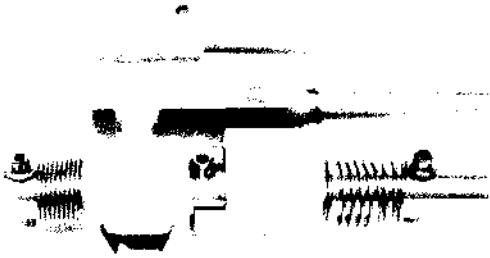


Fig. 13-72



Fig. 13-74 Main shaft and input shaft assembly

### Transmission Lower Case and Upper Case

- 1) With counter shaft ass'y, reverse idle gear and reverse gear shaft installed in lower case, check to ensure that bearing stopper rings ① are fitted in both sides of lower case as shown below.  
Also check for 2 knock pins ②.

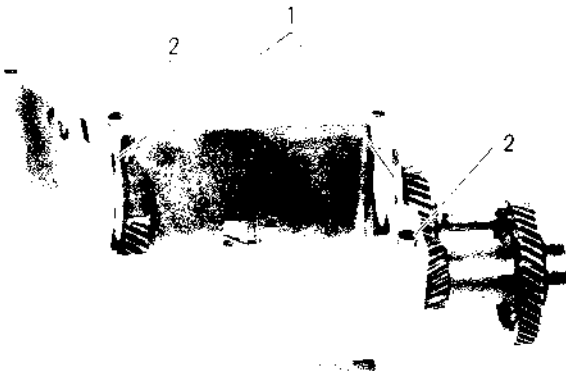


Fig. 13-73

- 2) Make sure that mating surfaces of both lower and upper cases are clean.
- 3) Install main shaft and input shaft ass'y in lower case.



Fig. 13-75

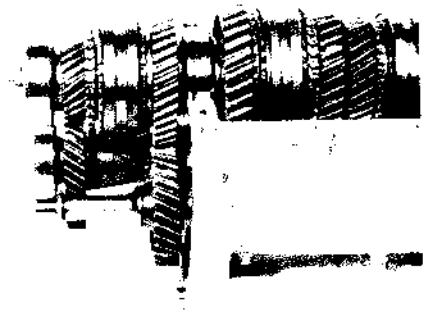


Fig. 13-76

- 4) Uniformly apply sealant (SUZUKI BOND NO. 1215, 99000-31110) to mating surface of lower case.

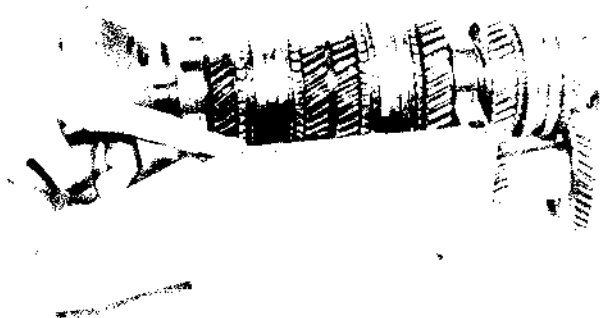


Fig. 13-77

- 5) Install upper case to lower case by matching 3 shift forks with 3 grooves in synchronizer sleeve on main shaft respectively.



Fig. 13-78 ① Shift forks

- 6) Tighten case bolts to specification.

Tightening torque for transmission case bolts	N·m	kg·m	lb·ft
	18 – 28	1.8 – 2.8	13.5 – 20.0

#### Extension Case

- 1) Check to ensure that knock pins ① are fitted.



Fig. 13-79

- 2) Apply grease (SUZUKI SUPER GREASE A 99000-25010) to oil seal lip.
- 3) Clean surface of extension case to mate with transmission case and uniformly apply sealant (SUZUKI BOND No. 1215, 99000-31110).



Fig. 13-80

- 4) Make sure that 3 shift shafts are in neutral position as shown in Fig. 13-23.
- 5) Install extension case to transmission case.
- 6) Tighten case bolts to specification.

Tightening torque for extension case bolts	N·m	kg·m	lb·ft
	18 – 28	1.8 – 2.8	13.5 – 20.0

- 7) Apply thread lock agent (THREAD LOCK CEMENT SUPER "1333B" 99000-32020) to thread of reverse gear shift rim bolt. And tighten rim bolt to extension case to specified torque.

Tightening torque for reverse gear shift rim bolt	N·m	kg·m	lb·ft
	14 - 20	1.4 - 2.0	10.5 - 14.0

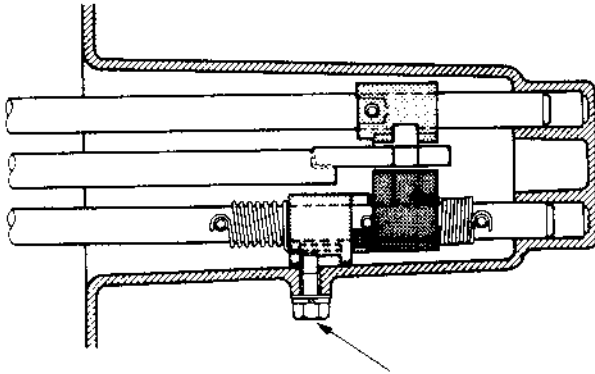


Fig. 13-81

#### Input Shaft Bearing Retainer

- 1) Apply grease (SUZUKI SUPER GREASE A 99000-25010) to oil seal lip.
- 2) Clean surface of retainer to mate with transmission case and uniformly apply sealant (SUZUKI BOND No. 1215, 99000-31110).



Fig. 13-82

- 3) Tighten retainer bolts to specification.

Tightening torque for retainer bolts	N·m	kg·m	lb·ft
	18 - 28	1.8 - 2.8	13.5 - 20.0

- 4) Check transmission input shaft for easy rotation by hand.
- 5) Check each select and shift shaft for operation.

#### Clutch Release Bearing

Before installing bearing, apply grease (SUZUKI SUPER GREASE A 99000-25010) to inner surface of clutch release bearing.

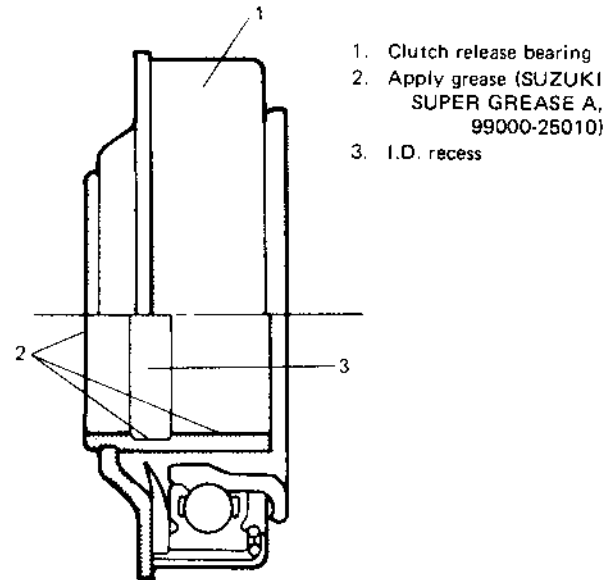


Fig. 13-83

#### Input shaft

Before remounting transmission ass'y to engine and car body, apply grease (SUZUKI SUPER GREASE I, 99000-25210) to input shaft.

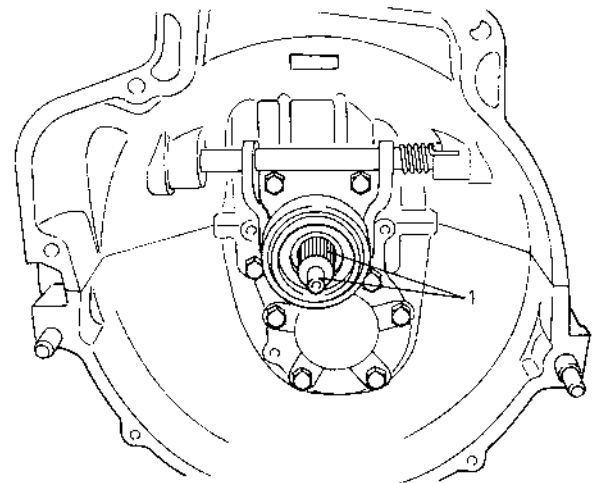


Fig. 13-84

1. Apply grease

#### Others

Upon completion of reassembly and installation of transmission ass'y in car body, pour specified amount of transmission oil into transmission, and check carefully for oil leakage. Refer to p. 13-25 for oil to be used and specified amount.

## 13-7. MAINTENANCE SERVICES

### Transmission Oil

Before changing oil, check for oil leakage first and correct defects, if any. Fill specified new oil in specified amount.

Oil capacity	1.3 litres (2.75/2.29 US/Imp. pt.)
Oil specification	Gear oil, SAE 80W-90, 75W-80 or 75W-90

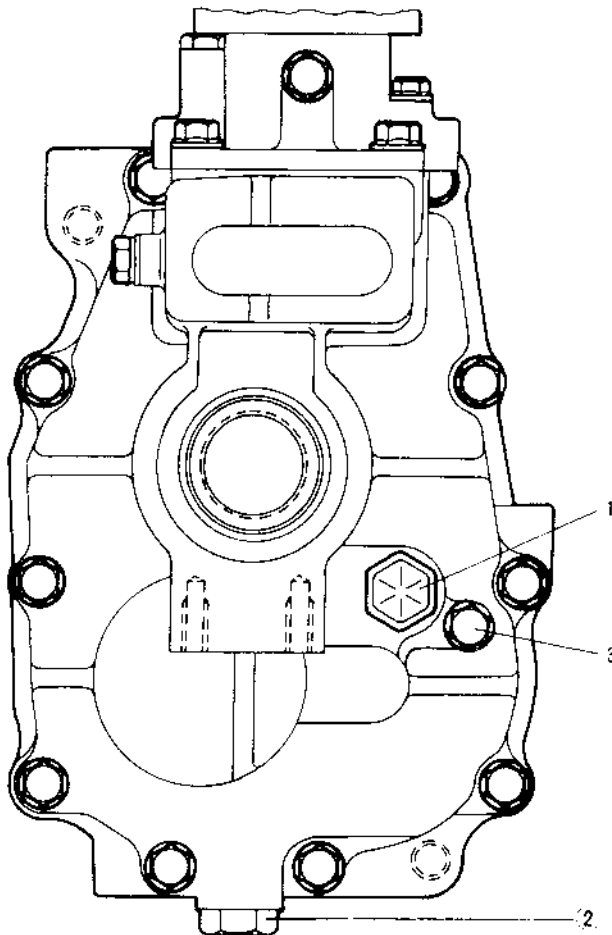
It is highly recommended to use SAE 75W-90 gear oil.  
For viscosity chart, refer to P. 1-17.

After filling transmission with oil, torque oil filler and drain plugs to specification.

Tightening torque	N·m	kg·m	lb·ft
for oil drain and filler plug	20 - 30	2.0 - 3.0	14.5 - 21.5
for oil level plug	10 - 16	1.0 - 1.6	7.5 - 11.5

### NOTICE:

Whenever car was hoisted for any other service work than oil change, also be sure to check for oil leakage.



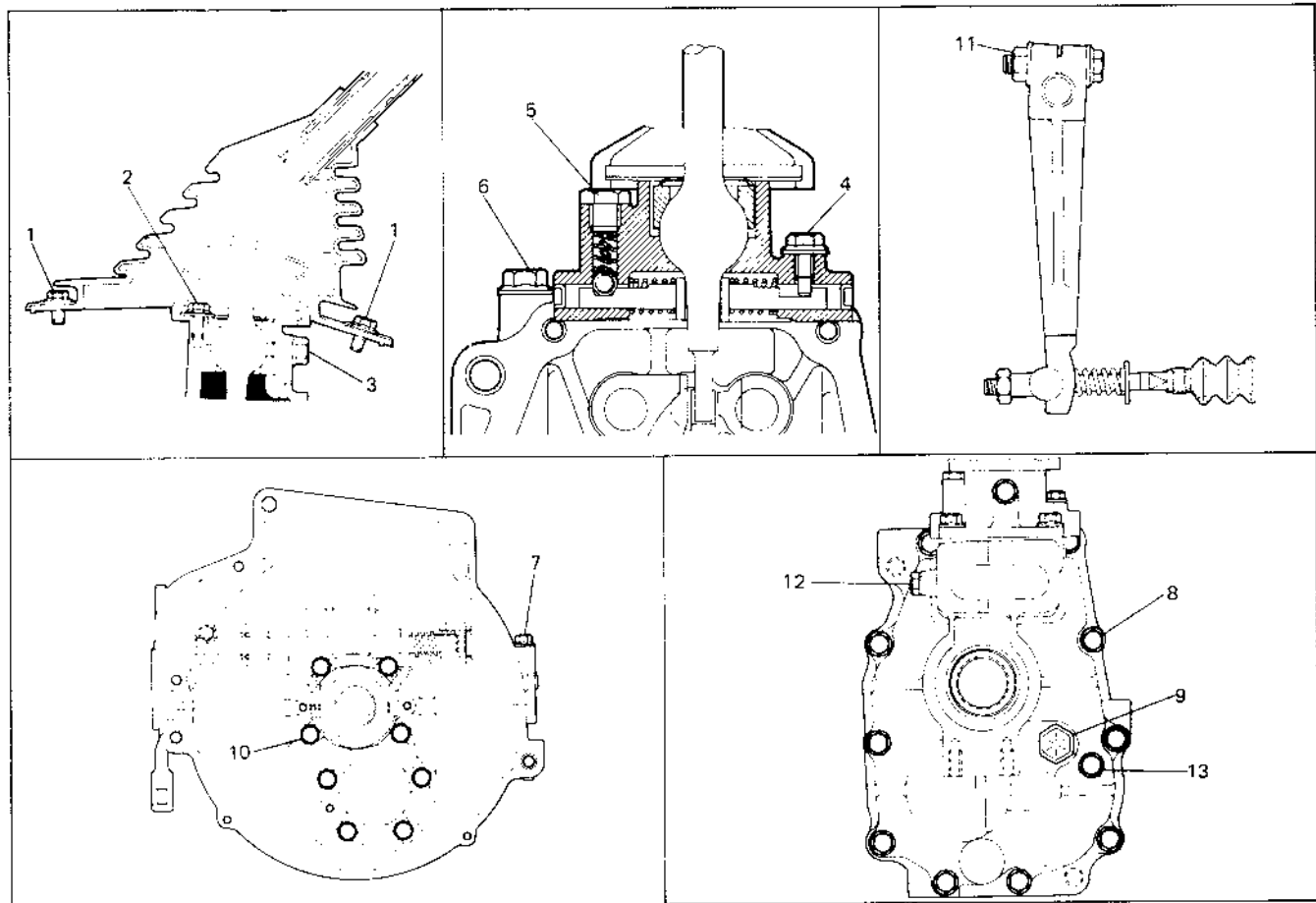
1. Oil filler plug
2. Oil drain plug
3. Oil level plug

Fig. 13-85

### 13-8. RECOMMENDED TORQUE SPECIFICATION

Be sure to torque each bolt and nut according to specification given below, whenever loosened. If specified torque for particular bolt or nut is not included in the list, refer to page 0-13.

System	Fastening parts	Tightening torque		
		N·m	kg·m	lb·ft
Gear shifting control	1. Gear shift control boot cover bolt	4 – 7	0.4 – 0.7	3.0 – 5.0
	2. Gear shift lever case cover bolt	4 – 7	0.4 – 0.7	3.0 – 5.0
	3. Control lever locating bolt	14 – 20	1.4 – 2.0	10.5 – 14.0
	4. Low speed select pin bolt	4 – 7	0.4 – 0.7	3.0 – 5.0
	5. Reverse select pin screw	25 – 35	2.5 – 3.5	18.5 – 25.0
	6. Gear shift lever case bolt	18 – 28	1.8 – 2.8	13.5 – 20.0
Transmission	7. Transmission case bolt	18 – 28	1.8 – 2.8	13.5 – 20.0
	8. Extension case bolt	18 – 28	1.8 – 2.8	13.5 – 20.0
	9. Transmission oil filler and drain plug	20 – 30	2.0 – 3.0	14.5 – 21.5
	10. Input shaft bearing retainer bolt	18 – 28	1.8 – 2.8	13.5 – 20.0
	11. Clutch release arm nut	10 – 16	1.0 – 1.6	7.5 – 11.5
	12. Reverse gear shift rim bolt	14 – 20	1.4 – 2.0	10.5 – 14.0
	13. Transmission oil level plug	10 – 16	1.0 – 1.6	7.5 – 11.5





## SECTION 14

# TRANSFER GEAR BOX

### CONTENTS

14-1.	GENERAL DESCRIPTION .....	14-2
14-2.	SELECTIVE FLOWS OF TRANSFER DRIVE .....	14-3
14-3.	GEAR RATIO DATA .....	14-4
14-4.	TRANSFER SERVICES NOT REQUIRING TRANSFER REMOVAL .....	14-5
14-5.	REMOVAL .....	14-6
14-6.	DISASSEMBLY .....	14-8
14-7.	INSPECTION OF COMPONENTS .....	14-12
14-8.	REASSEMBLY .....	14-14
14-9.	MAINTENANCE SERVICES .....	14-22
14-10.	TIGHTENING TORQUE .....	14-23

## 14-1. GENERAL DESCRIPTION

The transfer gear box is an auxiliary transmission for on-off control of two-speed drive transmitted to both front and rear axles concurrently and provides additional speed reductions, HIGH and LOW, for any selection of main transmission gears.

The functions of this auxiliary transmission are mainly two—selection between four-wheel drive (front and rear axles) and two-wheel drive (rear axle) and between HIGH and LOW for four-wheel drive. Three propeller shafts are associated with the gear box.

These functions are accomplished by means of four shafts arranged in three-axis configuration and two sliding clutches. The selection is effected by actuating these clutches from a single control lever located beside the driver's seat. The gear box is mounted on a chassis frame.

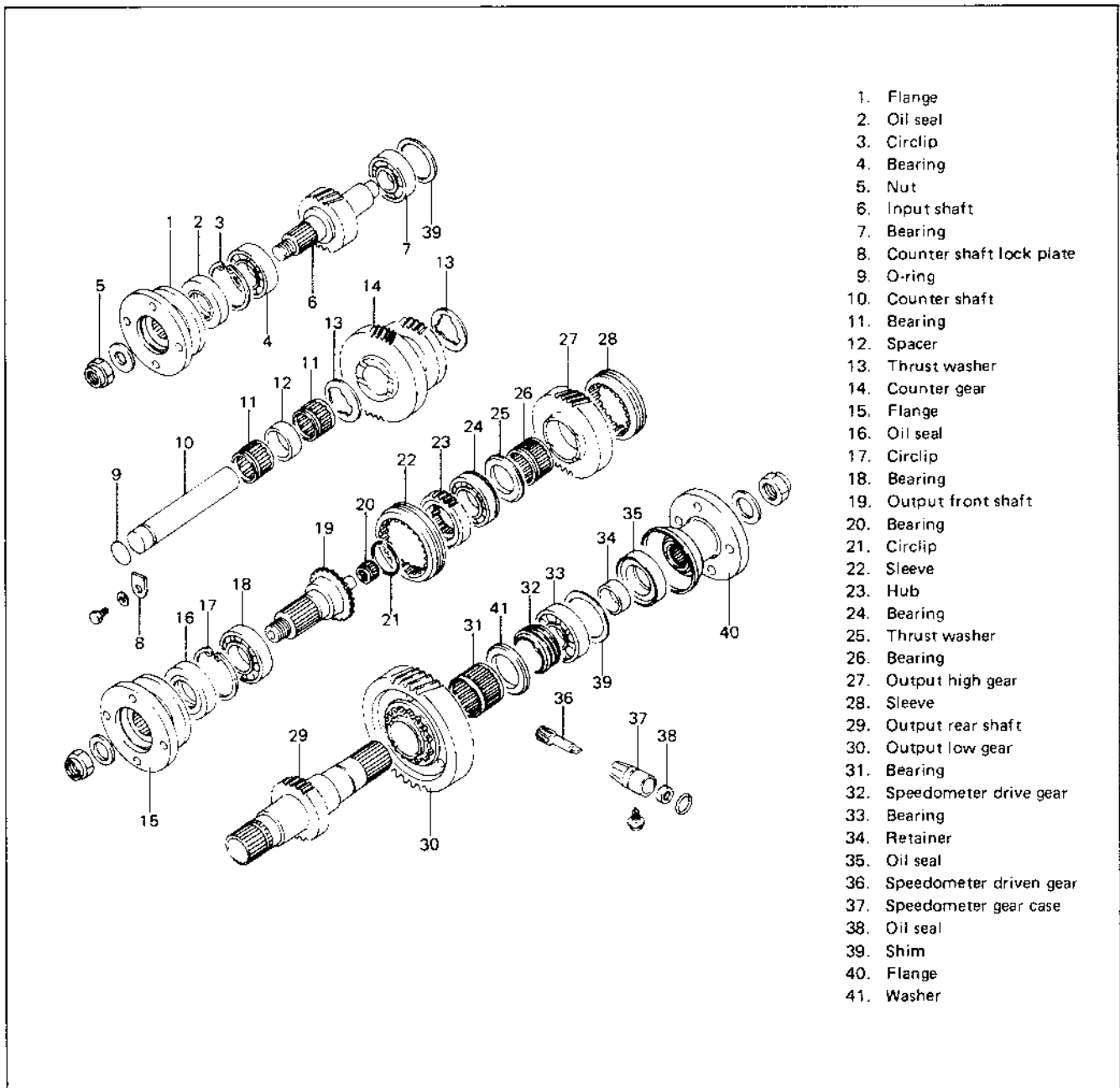


Fig. 14-1

## 14-2. SELECTIVE FLOWS OF TRANSFER DRIVE

### 2-Wheel Drive (Rear-Wheel Drive)

Rear shifter fork pushes rear clutch sleeve into "high" gear, thus coupling the gear to output rear shaft.

Drive flows from input shaft to output rear shaft through big gear, "high" gear and rear clutch.

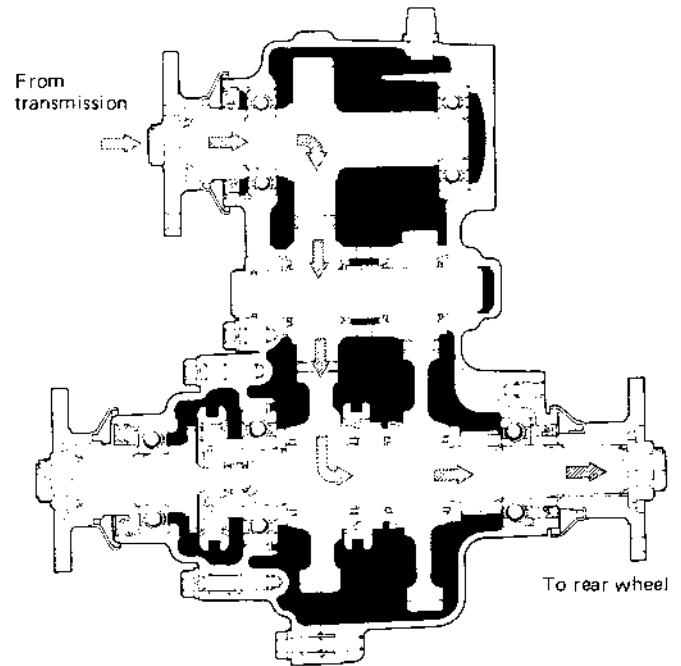
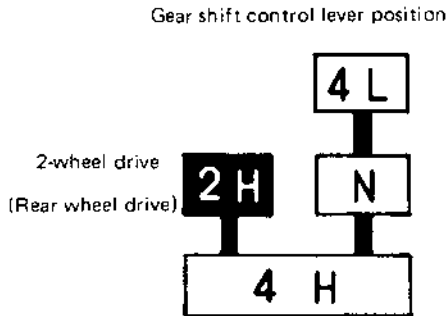


Fig. 14-2

### 4-Wheel Drive HIGH (All-Wheel Drive on HIGH)

Under the conditions of rear-wheel drive, described above, front shifter fork pushes the sleeve of front clutch onto the toothed clutch ring, thus coupling output rear shaft to output front shaft. Front shaft and rear shaft run together on HIGH.

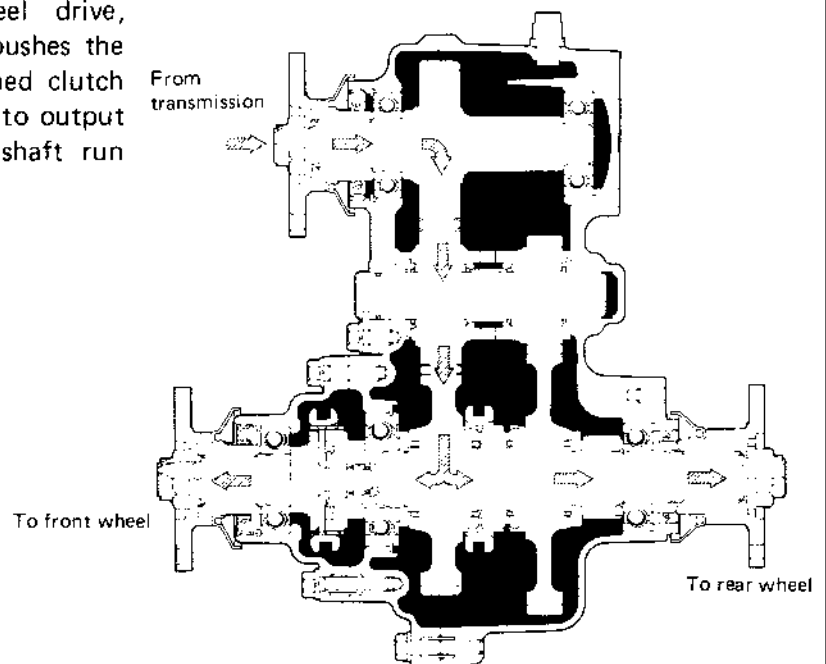
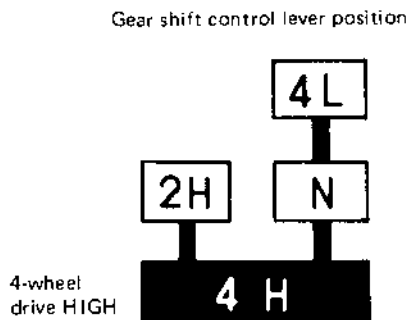


Fig. 14-3

**4-Wheel Drive LOW (All-Wheel Drive on LOW)**

Front shifter fork actuates front clutch to couple rear shaft to front shaft; and rear shifter fork actuates rear clutch to couple "low" gear to rear shaft. Front shaft and rear shaft run together on LOW.

Gear shift control lever position

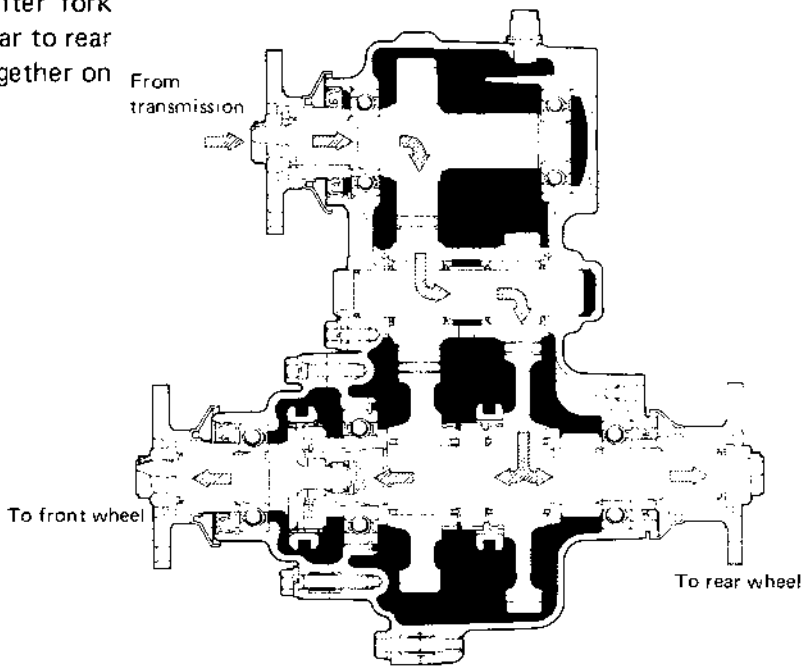
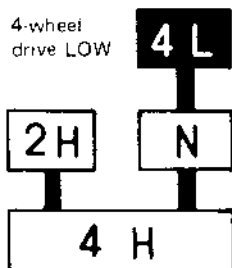


Fig. 14-4

**14-3. GEAR RATIO DATA**

Shift position	Rear-wheel drive	All-wheel drive high	All-wheel drive low
Gear	41/44 · 62/41	41/44 · 62/41	41/44 · 56/23
Reduction	1.409	1.409	2.268

#### 14-4. TRANSFER SERVICES NOT REQUIRING TRANSFER REMOVAL

Following parts or components do not require transfer removal to receive services (replacement, inspection) :

Part or Component	Nature of Service
1. Universal-joint yoke flanges	Replacement or inspection
2. Front drive shift shaft fork	Replacement or inspection
3. Transfer output front shaft oil seal	Replacement or inspection
4. Transfer output front shaft bearing	Replacement
5. Transfer output front shaft	Replacement
6. Transfer front case	Replacement
7. Front drive clutch hub	Replacement or inspection
8. Front drive clutch sleeve	Replacement or inspection
9. Transfer input shaft oil seal	Replacement
10. 4WD indicator light switch	Replacement or inspection
11. Speedometer driven gear	Replacement or inspection
12. Gear shift control lever	Replacement or inspection
13. Gear shift control boot No. 1, No. 2	Replacement
14. Gear shift control lever spring seat	Replacement or inspection

## 14-5. REMOVAL

- 1) Lift up car and remove securing bolts from each universal-joint flange connection to sever 3 propeller shafts from transfer gear box.



Fig. 14-5

- 2) Remove clamp ① and boot ② from transfer gear box.

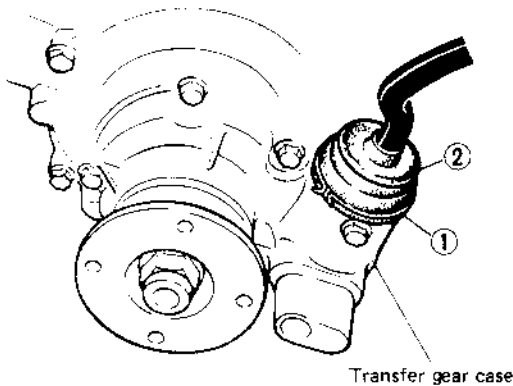


Fig. 14-6

- 3) Twist control lever guide counterclockwise while pushing it down; this will permit lever to be removed from gear box.

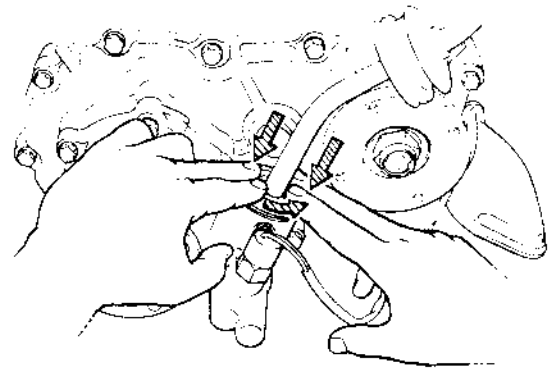


Fig. 14-7

- 4) Drain out oil from gear box by loosening its drain plug.



Fig. 14-8

- 5) Disconnect speedometer drive cable from transfer gear box.



Fig. 14-9

- 6) Disconnect 4WD switch lead wire at coupler.
- 7) Remove 3 mounting nuts securing gear box to chassis, and take down gear box.



*Fig. 14-11*

## 14-6. DISASSEMBLY

### Universal-Joint Yoke Flanges

There are 3 flanges to be removed: one from input shaft and other from output front and rear shafts. Lock flange so that it will not turn, and loosen and remove nut holding flange to the shaft. Draw off flange.



Fig. 14-12 (A) Special tool (09930-40113)

### Speedometer Driven Gear

Loosen speedometer driven gear case bolt and remove speedometer driven gear case with gear.



Fig. 14-15

### Transfer Front Case

Remove the indicator light switch from front case.

#### NOTICE:

Use care not to lose switch ball. This ball is larger than interlock ball and locating balls.

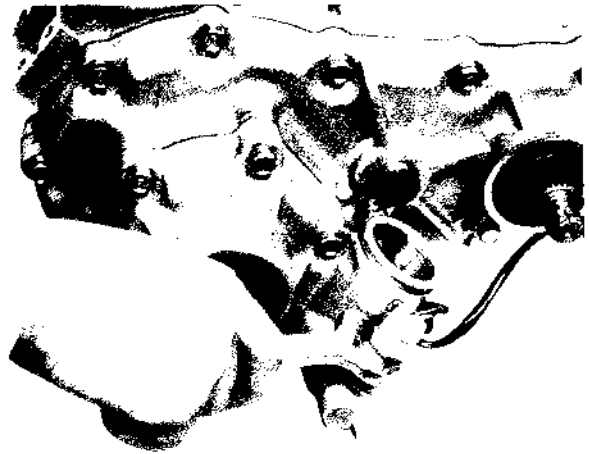


Fig. 14-16

Remove bolts securing transfer front case, and take off case.

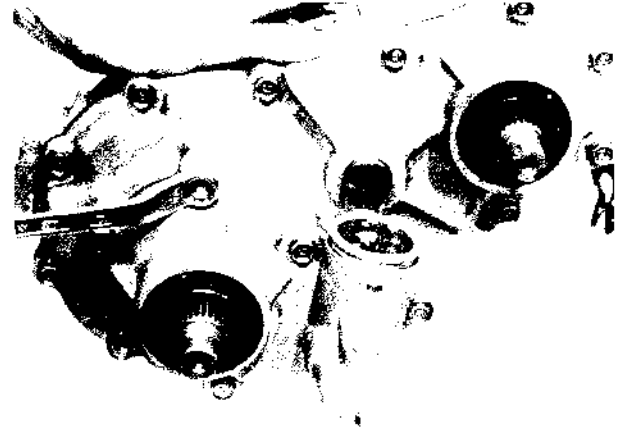


Fig. 14-17

By tapping output front shaft with a plastic hammer, remove output front shaft from front case.

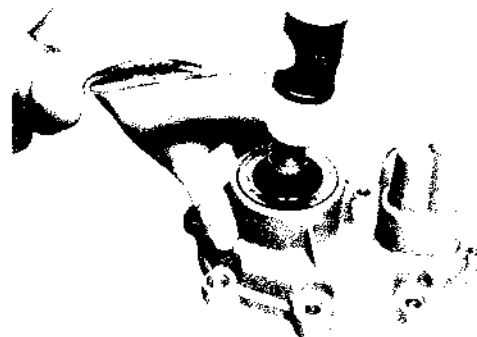


Fig. 14-18



After removing oil seal, remove circlip and drive bearing out of front case by using bearing installer (special tool).

Bearing installer © : (09913-76010)



Fig. 14-19

#### Transfer Center Case

Remove bolts fastening center case and rear case together.

Do not loosen bolt ① at this point.



Fig. 14-20

By tapping rear case and output rear shaft with a plastic hammer, separate center and rear case.



Fig. 14-21

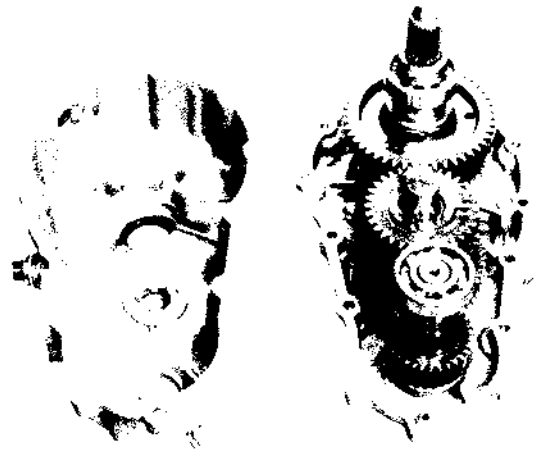


Fig. 14-22

Given below are procedures for disassembling component parts of center case as separated from rear case.

- 1) Loosen gear shift locating spring plug and take out spring and locating ball.

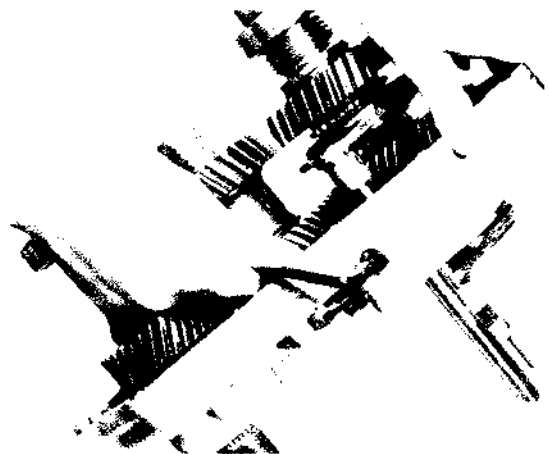


Fig. 14-23

- 2) Using spring pin remover (special tool), drive 2 spring pins out of front drive shift shaft ① and reduction shift shaft ②.  
Spring pin remover ④ : (09922-85811).

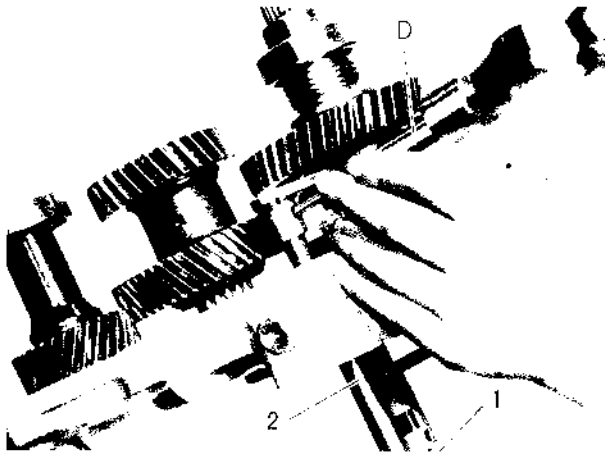


Fig. 14-24

- 3) Remove forks and shift shafts.

**NOTICE:**

At this time, locating ball and spring will jump out of hole, use care not to lose them.

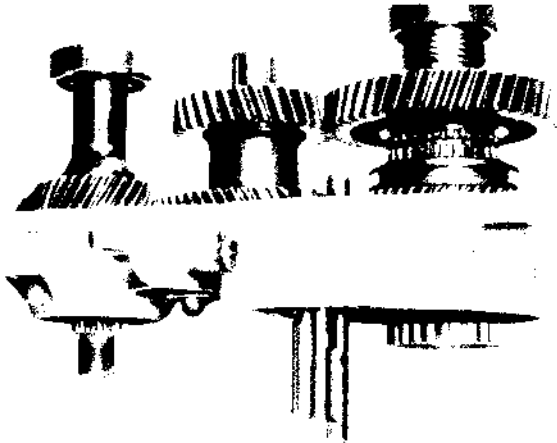


Fig. 14-25

- 4) Hammer output rear shaft with a plastic hammer to drive it out of center case.

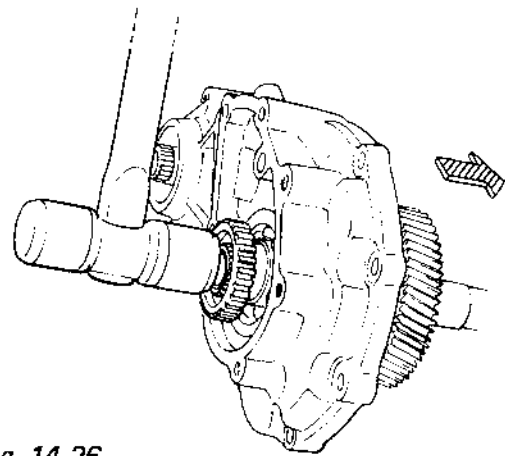


Fig. 14-26

- 5) Pull out counter gear, bearings and spacer. Remove counter shaft from center case by loosening counter shaft lock plate bolt.

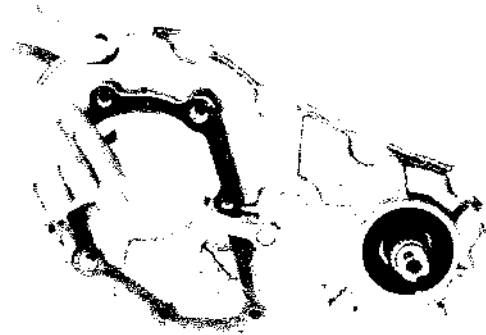


Fig. 14-27

- 6) Remove input shaft from center case by hammering thick part of case or input shaft center with a plastic hammer.

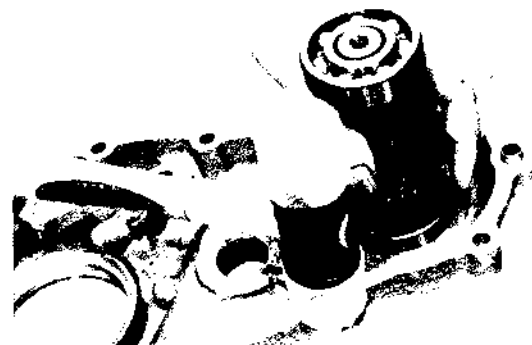


Fig. 14-28

- 7) Remove output shaft rear bearing and retainer together by using bearing puller. After removing bearing, speedometer drive gear, thrust washer, output low gear and needle roller bearing can be removed.

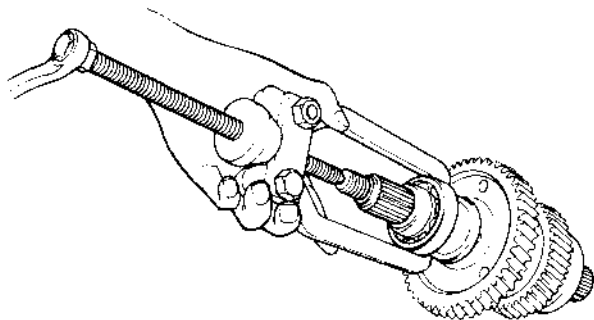


Fig. 14-29

- 8) Remove front drive clutch hub circlip and pull clutch hub off shaft by using bearing puller and puller attachment (special tool A).

**NOTICE:**

Use care to prevent damage to needle roller bearing in output rear shaft when removing clutch hub.

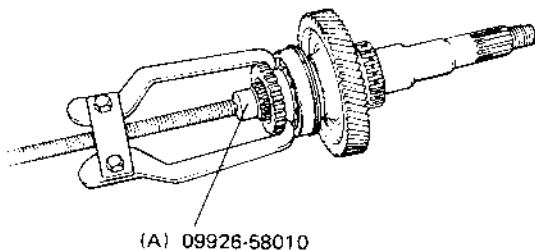


Fig. 14-30

- 9) Remove front bearing by using bearing puller and puller attachment (special tool A).

**NOTICE:**

Use care to prevent damage to needle roller bearing in output rear shaft while bearing is being removed.

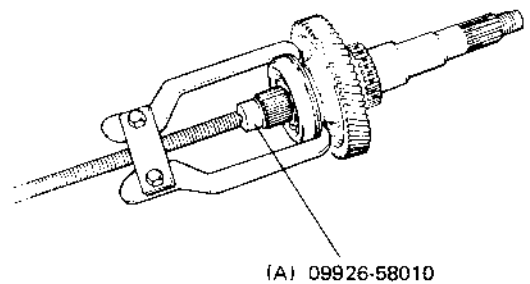


Fig. 14-31

- 10) When input shaft is removed or center case and rear case are separated, input shaft bearings may come off. In such a case, bearings can be removed from shaft by using bearing puller.



Fig. 14-32

11) When input shaft is removed, front bearing may be left in case. In this case, after removing oil seal and circlip, bearing can be taken out of case by using bearing installer (special tool).

Bearing installer (E) : (09913-75810)



Fig. 14-33

#### Transfer Rear Case

1) When center case and rear case are separated, input shaft may be left in rear case. In this case, remove input shaft from rear case by hammering thick part of case with a plastic hammer.



Fig. 14-34

## 14-7. INSPECTION OF COMPONENTS

### Gear Teeth

Inspect gear teeth (1), internal teeth of rear clutch sleeve (2) and clutch teeth of gear (3) for wear, cracking, chipping and other malcondition. Replace gear or sleeve as necessary.

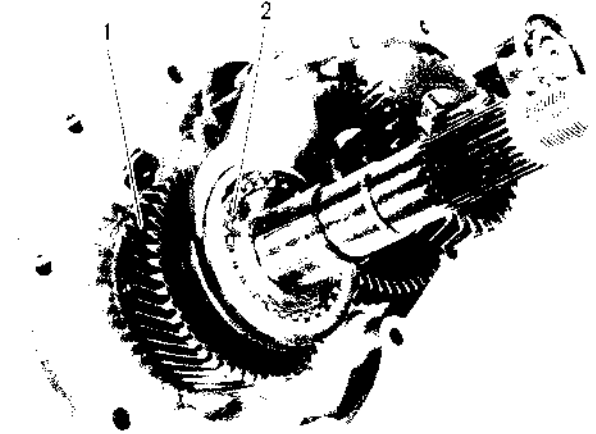


Fig. 14-35

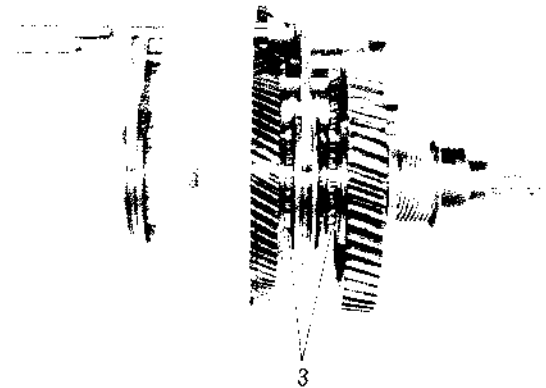


Fig. 14-36

### Locating Spring

Check each shifter fork shaft locating spring for strength by measuring its free length. If length is noted to be less than service limit, replace it.

Free length of locating spring	Standard	Service limit
	23.7 mm (0.933 in)	22.0 mm (0.866 in)

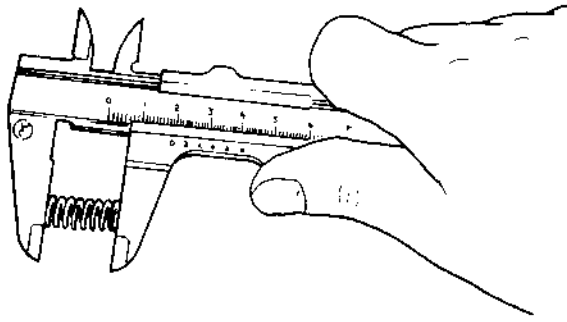


Fig. 14-37

### Bearings

Check each bearing by spinning its outer race by hand to "feel" smoothness of rotation. Replace bearing if noted to exhibit sticking, resistance or abnormal noise when spun or rotated by hand.

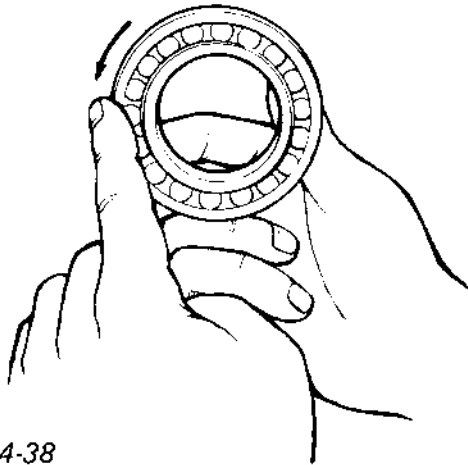


Fig. 14-38

### Side Clearance of Gears

With gear, bearing and thrust washer installed on shaft, check for side clearances of gears. If clearance exceeds service limit, replace thrust washer.

Side clearance of gear		Standard	Service limit
Output gears	low gear	0.175 – 0.325mm	0.7 mm
	high gear	(0.007 – 0.012in)	(0.027 in)

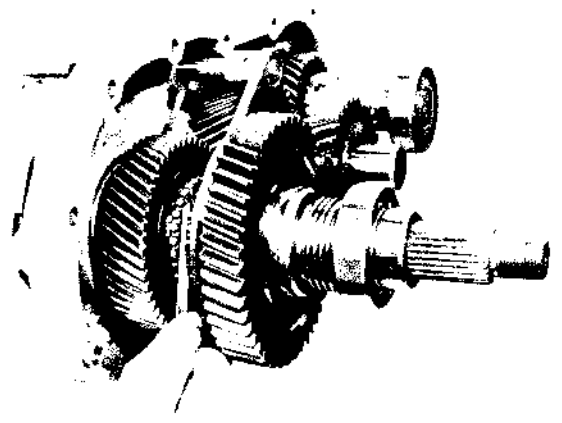


Fig. 14-39 Output high gear

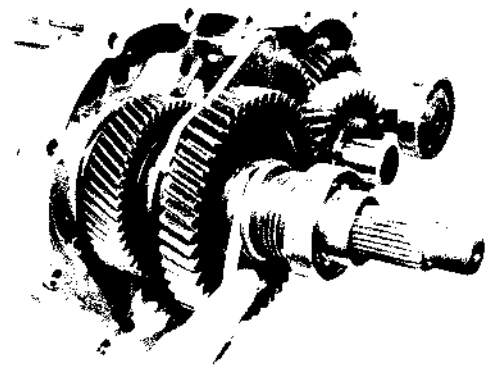


Fig. 14-40 Output low gear

### Gear Shift Shafts

Check each part as indicated in below figures for uneven wear. Replace defective parts.



Fig. 14-41

#### 4WD Gear Shift Lever

Check lower end of gear shift lever where gear shift fork shaft contacts ① for wear and any kind of damage. Worn or damaged shift lever must be replaced with new one.

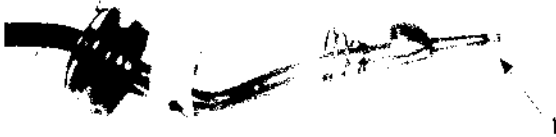


Fig. 14-42

## 14-8. REASSEMBLY

### NOTICE:

- All parts to be used in reassembly must be perfectly clean.
- Oil or grease sliding and rubbing surfaces of transfer components just before using them in reassembly with gear oil and SUZUKI SUPER GREASE A (99000-25010).
- Oil seals, "O" rings, gaskets and similar sealing members must be in perfect condition. For these members, use replacement parts in stock.
- Tightening torque is specified for important fasteners – mainly bolts – of transfer and other components. Use torque wrenches and constantly refer to specified data given in P. 14-23.

### Input Shaft

Press-fit bearings onto both sides of input shaft by using bearing installer (special tool).

Bearing installer (A) : (09913-84510)



Fig. 14-43

### Output Rear Shaft

Install following parts onto shaft in such order and directions as prescribed in the figure.

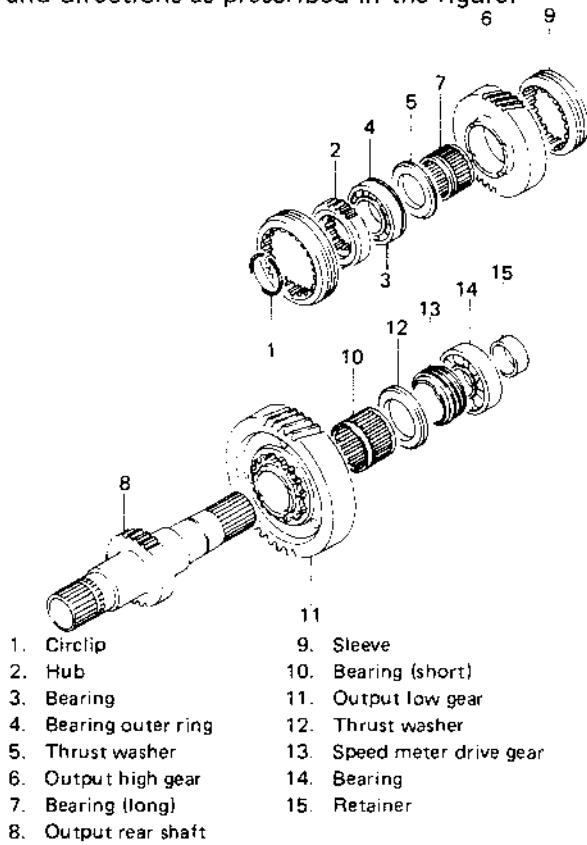


Fig. 14-44

1) After installing bearing (long), high gear and thrust washer, press-fit bearing ③ and then hub ② by using bearing installer (special tool).

Bearing installer (A) : (09913-84510)

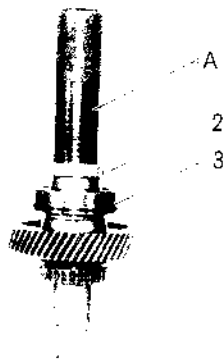


Fig. 14-45

2) Fit circlip ① securely into groove in shaft.

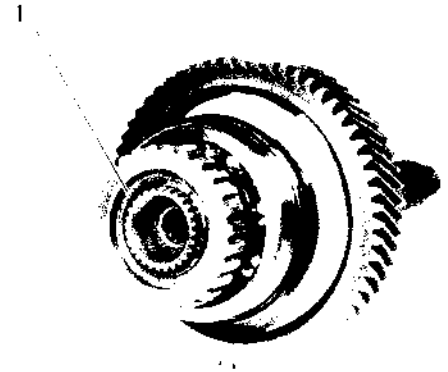


Fig. 14-46

3) After installing sleeve, bearing (short), low gear and thrust washer, press-fit speedometer drive gear by using bearing installer (special tool).

Bearing installer (A) : (09913-84510)

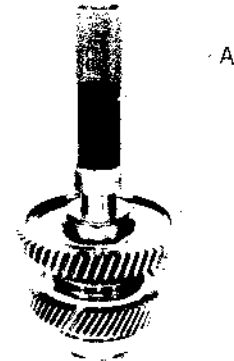


Fig. 14-47

4) Press-fit bearing ⑭ and the retainer ⑮ by using bearing installer (special tool).

Bearing installer (A) : (09913-84510)

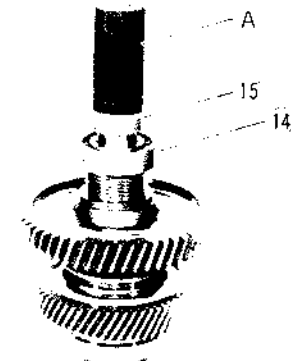


Fig. 14-48

### Shim Adjustment of Input and Output Shafts

Clearance in thrust direction of both input and output shafts is adjusted by putting shims between input shaft rear bearing and rear case for input shaft and between output shaft rear bearing and rear case for output shaft.

As thrust clearance is specified as follows, determine shim thickness to meet specification according to the following procedures.

Thrust clearance specification	0.05 – 0.15 mm (0.002 – 0.006 in.)
--------------------------------	---------------------------------------

#### [Input shaft]

- 1) Take measurement "A" of rear case as shown in figure below by using depth gauge.
- 2) Take measurement "B" of center case with bearing circlip installed.
- 3) Take measurement "C" (between bearing inner races) of input shaft with bearings installed, by using micrometer.

#### NOTICE:

- Before measuring, make sure that each bearing is free from abnormal noise or resistance by spinning its outer race.
- Each measurement in above steps 1) to 3) must be taken accurately in careful manner. If shim thickness is determined based on rough measurement, clearance of each shaft in thrust direction will not satisfy specification. And improper clearance may cause oil leakage, broken bearing and abnormal noise.
- Take the same measurement at 3 to 4 different positions and use their mean.

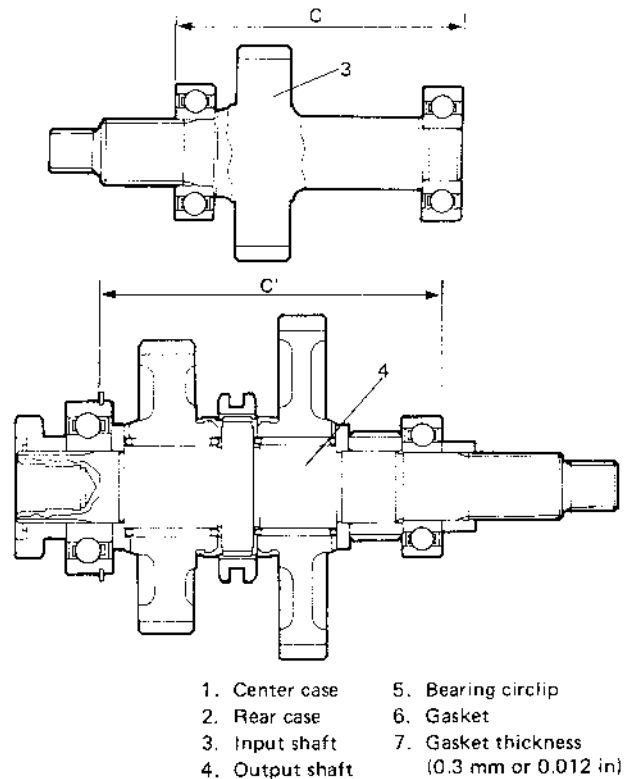
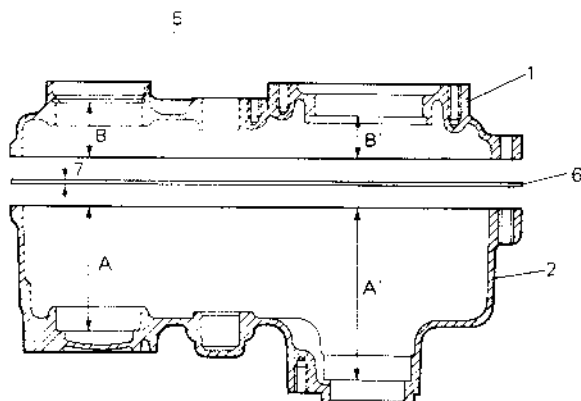


Fig. 14-48-1

- 4) Using measurements obtained in steps 1) to 3) and equation described below, calculate shim thickness which is necessary for proper thrust clearance.

$$\text{Thrust clearance} = ("A" + "B" + \text{Gasket thickness}) - "C"$$

As the above equation holds for thrust clearance and gasket thickness is specified as 0.3 mm and thrust clearance as 0.05 to 0.15 mm, shim thickness is calculated by the following equation.

$$\text{Shim thickness} = ("A" + "B" + 0.3) - ("C" + 0.05 \sim 0.15)$$

#### [Example]

Supposing A, B and C are as follows;

$$A = 81.35 \text{ mm (3.203 in.)}$$

$$B = 35.70 \text{ mm (1.405 in.)}$$

$$C = 117.05 \text{ mm (4.608 in.)}$$

$$\begin{aligned} \text{Shim thickness} &= (81.35 + 35.70 + 0.3) - \\ &\quad (117.05 + 0.05 \sim 0.15) \\ &= 117.35 - 117.10 \sim 117.20 \\ &= 0.25 \sim 0.15 \end{aligned}$$

In this case, use of 0.15 to 0.25 mm (0.006 to 0.009 in) thick shim(s) will ensure specified thrust clearance which is 0.05 to 0.15 mm (0.002 to 0.006 in). Therefore 2 pieces of 0.1 mm (0.004 in) thick shim should be selected in available shims below to satisfy thickness.

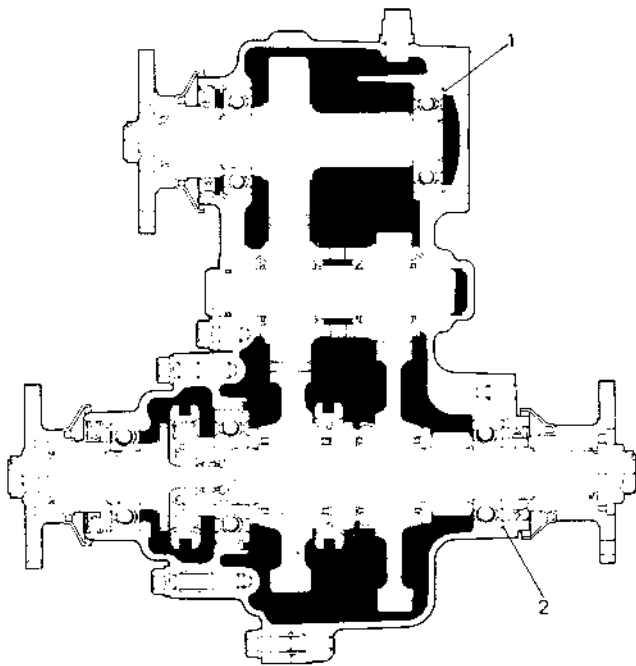


5) When shim thickness is determined, select proper shim(s) from among the following shims and use it (them) between input shaft rear bearing and rear case when matching center case and rear case.

Available shim size (thickness)	0.1, 0.3, 0.5 mm (0.004, 0.012, 0.020 in.)
---------------------------------	---

[Output shaft]

Just as with input shaft, take measurements of "A'", "B'" and "C'" as indicated in Fig. 14-48-1, calculate shim thickness and install proper shim(s) between output shaft rear bearing and rear case when matching center case and rear case.



1. Shim for input shaft
2. Shim for output shaft

Fig. 14-48-2

### Rear Case

- 1) Install oil seal in rear case and apply grease to oil seal lip.



Fig. 14-49

- 2) Install counter shaft thrust washer to rear case, bringing its face without depressions against case and fit its bent portion securely into groove in case.

### NOTICE:

Apply ample amount of grease to both surfaces of washer so as to lubricate sliding surfaces and prevent washer from moving out of place or slipping off.



Fig. 14-50

### Center Case

- 1) Install input shaft front bearing circlip and oil seal in center case.  
Snap ring pliers (A) : (09900-06108)

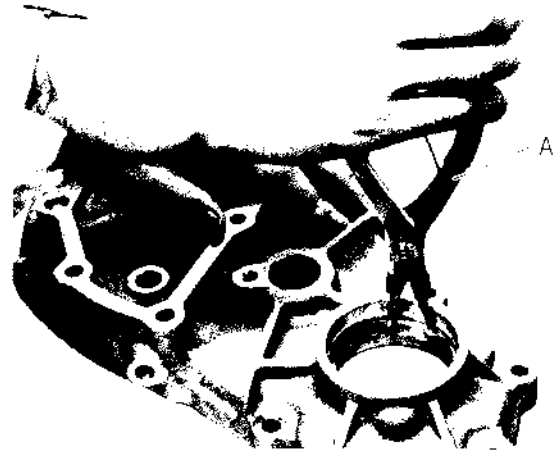


Fig. 14-51

- 2) Install input shaft to center case.

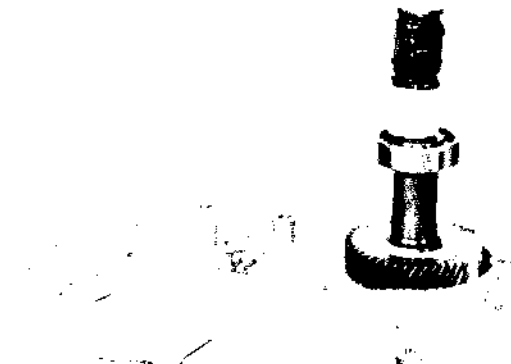


Fig. 14-52

- 3) After greasing O ring on counter shaft, insert shaft into center case and secure shaft with lock plate and bolt.

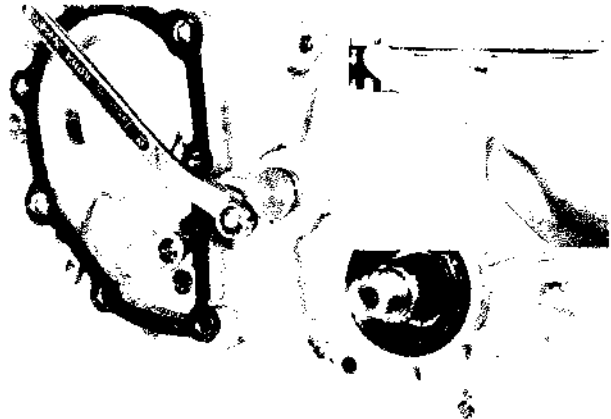


Fig. 14-53

4) Install the counter shaft thrust washer to center case. For installation, apply ample amount of grease to both faces of the washer so as to lubricate sliding surfaces and prevent it from moving out of place or slipping off and bring its face without depressions against center case, and fit its bent portion into groove in case securely.

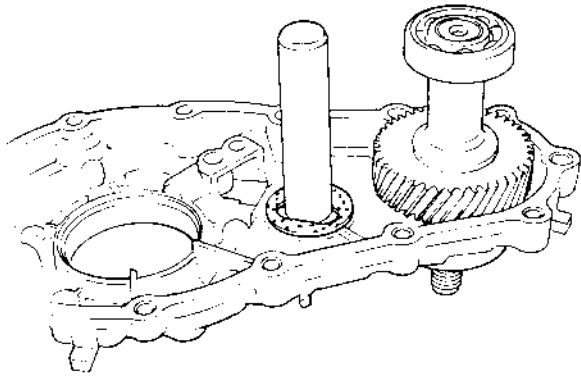


Fig. 14-54

5) Install needle roller bearings, spacer and counter gear on counter shaft.

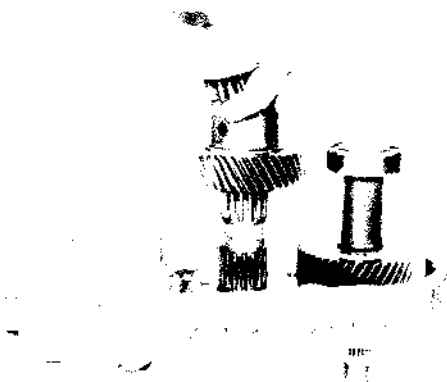


Fig. 14-55

6) Install output shaft assembly to center case.

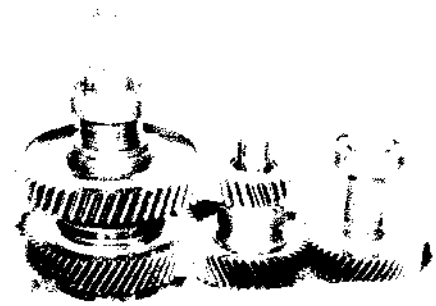


Fig. 14-56

7) When installing front drive shift shaft and reduction shift shaft in center case, install spring ①, ball ②, shaft ③, ball ④, shaft ⑤, ball ⑥, spring ⑦ and plug ⑧ in that order.

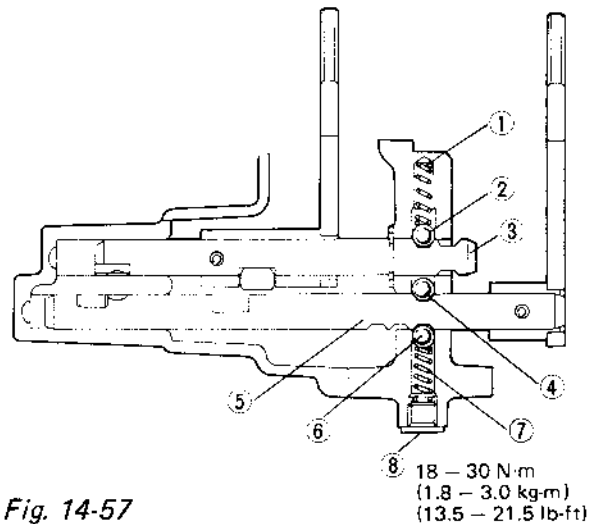


Fig. 14-57

8) Fit forks on shift shafts and lock them with spring pins. Forks should be fitted in correct direction according to below figure.

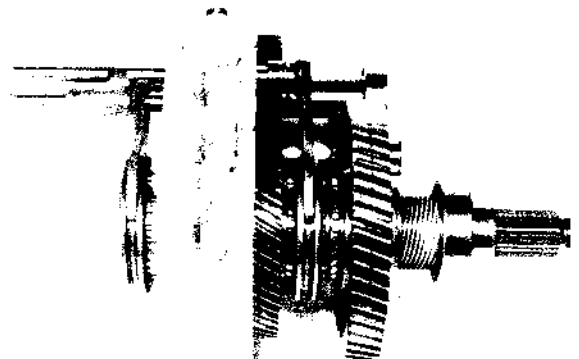


Fig. 14-58

### Center and Rear Cases

- 1) Check center case (or rear case) to ensure that it is provided with 2 dowel pins ①.



Fig. 14-59

- 2) Put gasket on center case. Bring rear case and center case into match and apply uniform force gradually all around rear case with a plastic hammer. Tighten center case securing bolts to specified torque.

#### NOTICE:

- Matching must be made carefully so as not to move countershaft thrust washers out of place.
- Be sure to install shims determined in previous item "Shim Adjustment of Input and Output Shafts" between input shaft rear bearing and rear case and between output shaft rear bearing and rear case.



Fig. 14-60



Fig. 14-61

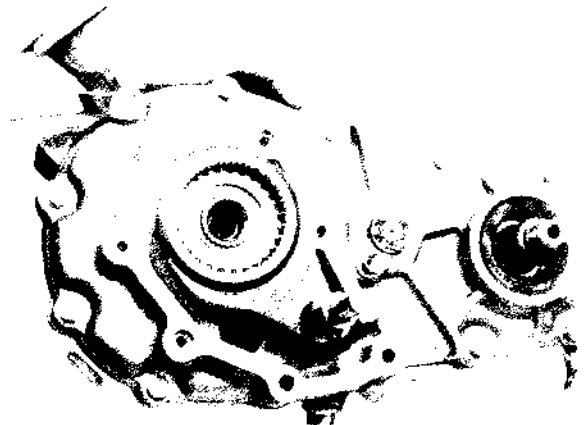


Fig. 14-62

- 3) Apply grease to output front shaft rear bearing.



Fig. 14-63

## Front Case

- 1) Install bearing, circlip and oil seal to front case. Apply grease to oil seal lip and install output front shaft using bearing installer (special tool).

Bearing installer (A) : (09913-76010)

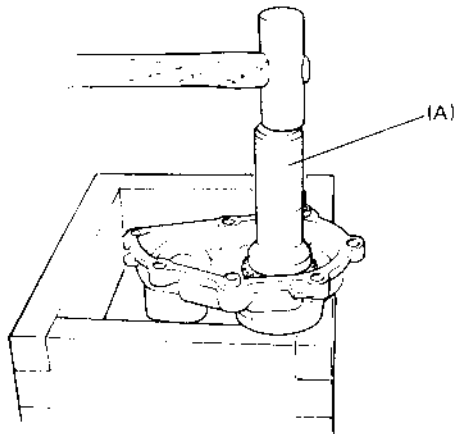


Fig. 14-64

- 2) Put gasket on center case.
- 3) Check front case to ensure that it is provided with 2 dowel pins.



Fig. 14-65

- 4) Install front case to center case.



Fig. 14-66

- 5) When installing speedometer driven gear and its gear case in rear case, apply grease to O ring and oil seal lip, and align bolt holes in rear case and driven gear case.



Fig. 14-67

- 6) Install 4WD ball and switch. Then clamp switch lead wire properly.

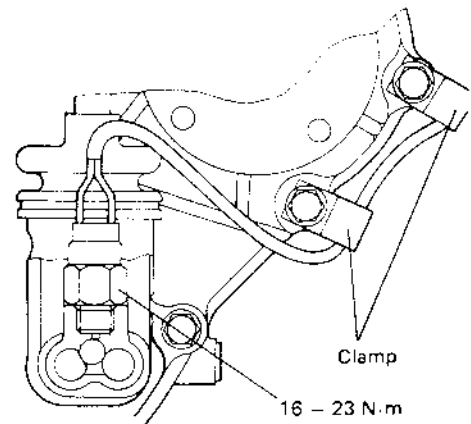


Fig. 14-68

16 - 23 N.m  
1.6 - 2.3 kg-m  
(12.0 - 16.5 lb-ft)

- 7) Install propeller shaft flanges and tighten nuts to specified torque and calk the nuts.
- 8) Upon completion of entire assembly work, install transfer in chassis body in reverse sequence of removal. Pour gear oil into transfer gear box.
- Refer to information given in next oil and oil capacity for oil to be used and specified amount.

## 14-9. MAINTENANCE SERVICES

### Oil Level

Oil level must be checked with car held in horizontal position in both front to rear and side to side directions.

Oil level plug and oil filler plug are one and the same as shown in figure.

If oil flows out of filler plug hole or if oil level is found up to hole when plug is removed, amount of oil is appropriate. Replenish oil if noted as insufficient.

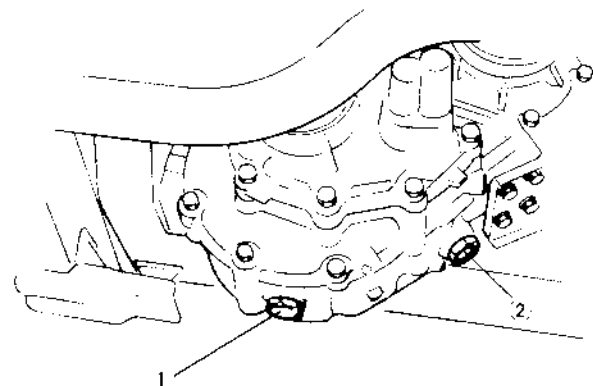
### Oil and Oil Capacity

Whenever car is lifted up for any service including oil change, make sure to check around transfer gear box for oil leakage. Correct defects, if any, and change or refill oil.

Transfer oil capacity	0.8 litre (1.7/1.4 US/imp. pt)
Transfer oil specification	Gear oil SAE 80W-90, 75W-80 or 75W-90

It is highly recommended to use SAE 75W-90 gear oil.

For viscosity chart, refer to P.1-17.



- ① : Oil drain plug
- ② : Oil filler & level plug

Fig. 14-70

## 14-10. TIGHTENING TORQUE

Fastening parts	N·m	lb·ft
	kg·m	
Front case bolt	13 – 23	9.5 – 16.5
	1.3 – 2.3	
Center case bolt	13 – 23	9.5 – 16.5
	1.3 – 2.3	
Counter shaft lock plate bolt	9 – 17	7.0 – 12.0
	0.9 – 1.7	
Universal joint flange nut	110 – 150	80.0 – 108.0
	11.0 – 15.0	
Transfer mounting bracket bolt	18 – 28	13.5 – 20.0
	1.8 – 2.8	
Transfer mounting nut	25 – 35	18.5 – 25.0
	2.5 – 3.5	
Cross joint bolt & nut	23 – 30	17.0 – 21.5
	2.3 – 3.0	
Oil filler and drain plug	36 – 54	26.5 – 39.0
	3.6 – 5.4	





## SECTION 15

# PROPELLER SHAFTS

### CONTENTS

15-1. GENERAL DESCRIPTION .....	15-2
15-2. REMOVAL .....	15-3
15-3. INSTALLATION .....	15-3
15-4. MAINTENANCE SERVICES .....	15-4
15-5. TIGHTENING TORQUE .....	15-5
15-6. DISASSEMBLY .....	15-6
15-7. REASSEMBLY .....	15-7

## 15-1. GENERAL DESCRIPTION

These automobiles, covered in this manual are four-wheel drive machines and, as such, use three propeller shafts designated as No. 1, No. 2 and No. 3.

No. 1 propeller shaft transmits drive from the transmission to the transfer gear box. No. 2 shaft and No. 3 shaft extend from the transfer gear box, the former driving the front axle and the latter the rear axle.

The cross spider in each universal joint is fitted with four needle roller bearings.

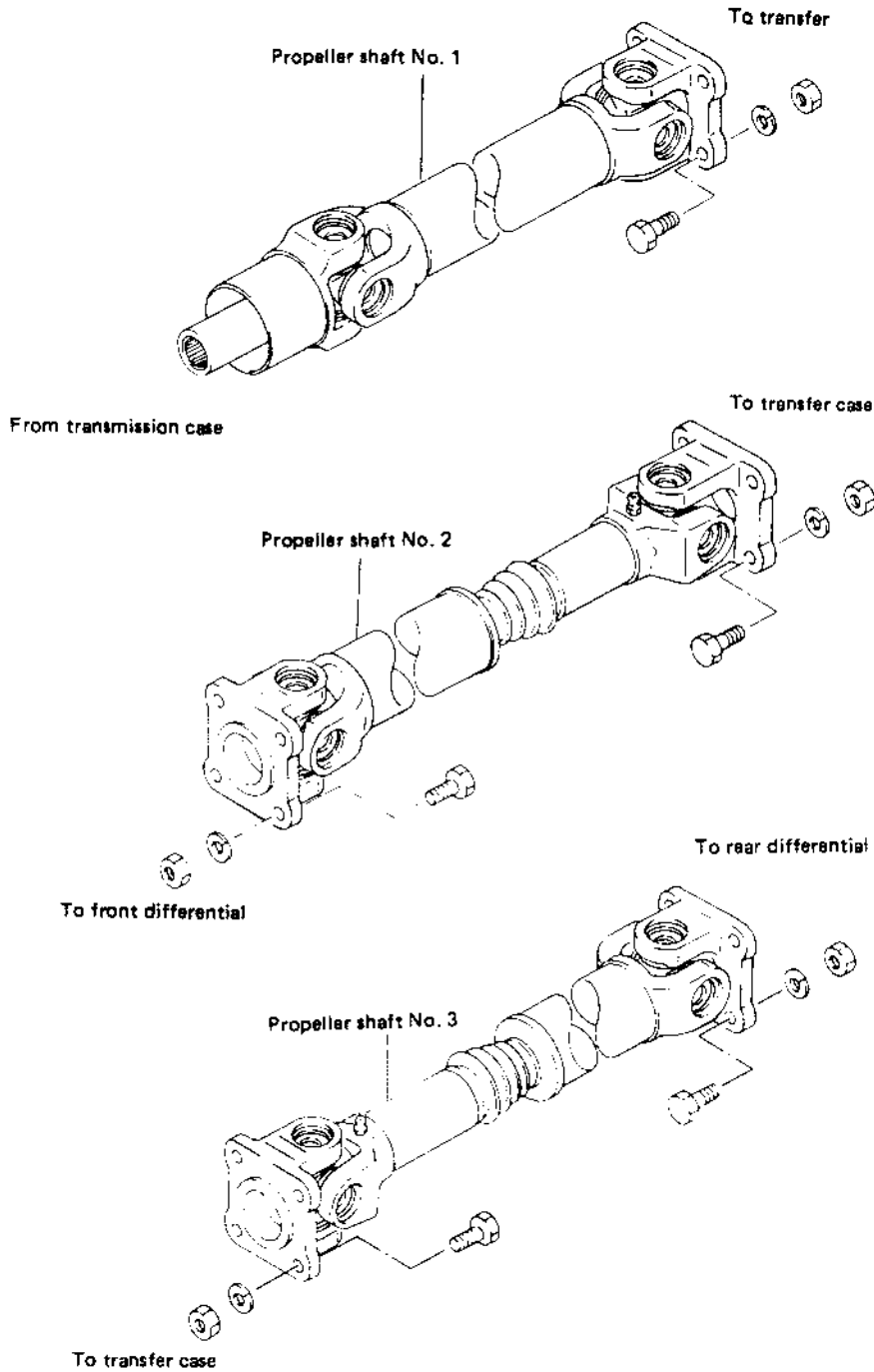


Fig. 15-1

## 15-2. REMOVAL

- 1) Hoist car.
- 2) Loosen propeller shaft nuts and bolts.
- 3) Remove propeller shaft.

Transmission-side end of No. 1 shaft has no flange piece; this end is splined to driving shaft inside extension case. All you have to do there is to pull No. 1 shaft off extension case.

### NOTICE:

When withdrawing propeller shaft No. 1 from transmission, transmission oil will not leak, provided oil level is to specification and car is raised horizontally in its front and rear direction. However, if only car front is hoisted, be sure to drain transmission oil before withdrawing propeller shaft No. 1.

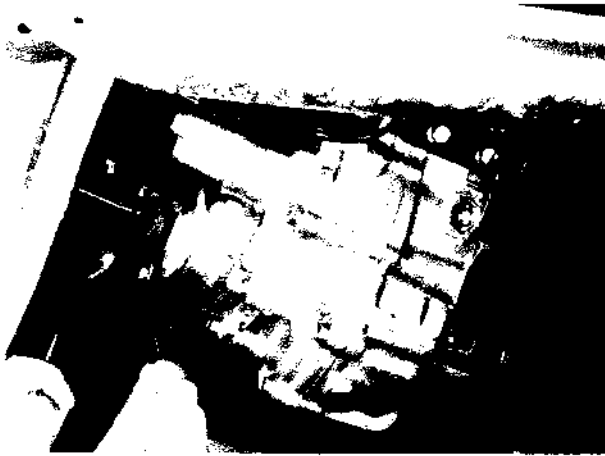


Fig. 15-2

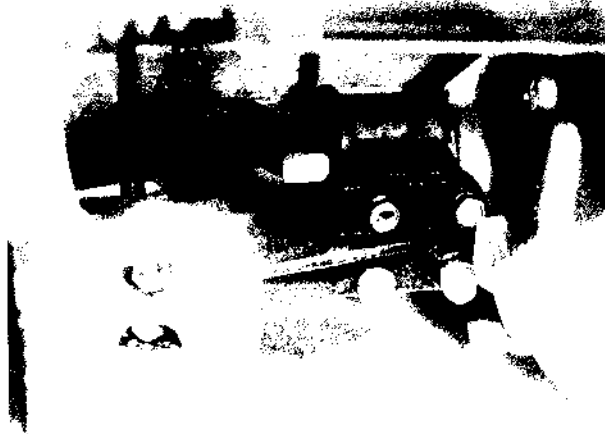


Fig. 15-3

## 15-3. INSTALLATION

The installing procedure is reverse of the removal procedure. Be sure to adhere to following instructions when installing shafts:

- Flange tightening torque  
Be sure to tighten 4 nuts to the following torque when securing companion flange to yoke at each end of propeller shaft:

Tightening torque for universal joint flange bolts & nuts	23 – 30 N·m (2.3 – 3.0 kg·m) (17.0 – 21.5 lb·ft)
---	--



Fig. 15-4

- Grease splines liberally, filling grooves with grease.

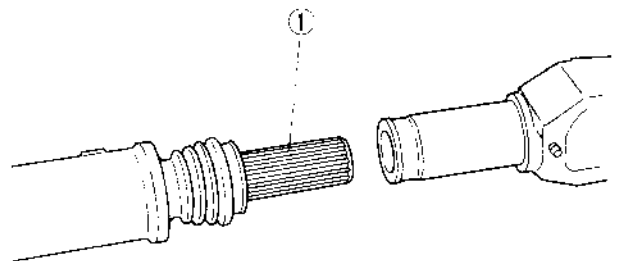


Fig. 15-5 ① Grease (chassis grease)

- Joint sheath rubber has a large diameter in one end and a small diameter in the other. Be sure to fit sheath rubber with its large-diameter end brought to joint yoke side.

2



Fig. 15-6 ② Joint sheath rubber

**NOTICE:**

If transmission oil was drained for propeller shaft No. 1 removal, pour specified gear oil into transmission case to specified level.

- Match marks are provided on slip-on spline connections. Inserting splined end into splined bore without regard to match marks can be a possible cause of noise or vibration of propeller shaft. Be sure to index marks.

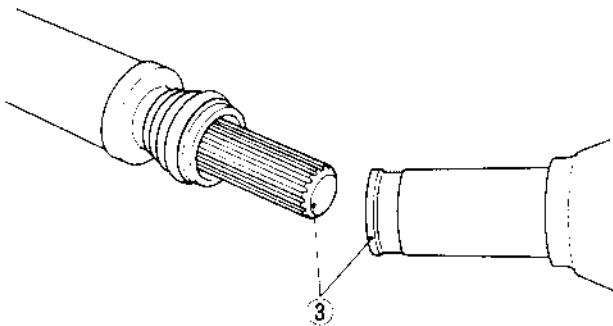


Fig. 15-7 ③ Match marks

## 15-4. MAINTENANCE SERVICES

### Lubrication

Inside yoke of each universal joint has a grease nipple. At regular intervals stated in the recommended servicing schedule, pump in grease to relubricate joint. Use chassis grease.

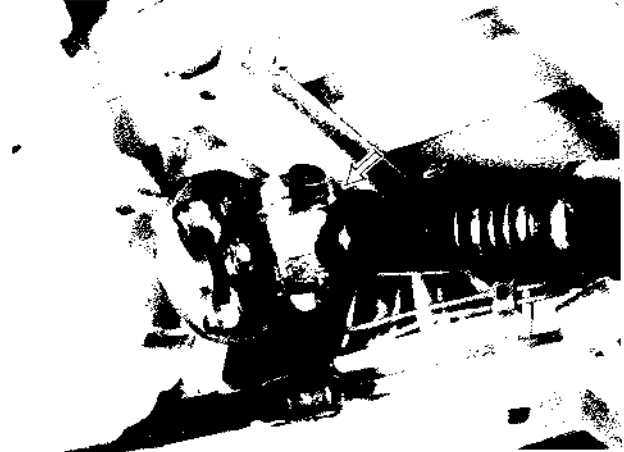


Fig. 15-8

### Universal Joint Noise

If universal joints are suspected of producing chattering or rattling noise, inspect them for wear. Check to see if cross spider rattles in yokes or if splines are worn down and replace defective propeller shaft with new one.

The noise coming from universal joint can be easily distinguished from other noises because rhythm of chattering or rattling is in step with cruising speed. Noise is pronounced particularly on standing start or in coasting condition (when braking effect of engine is showing in the drive line).

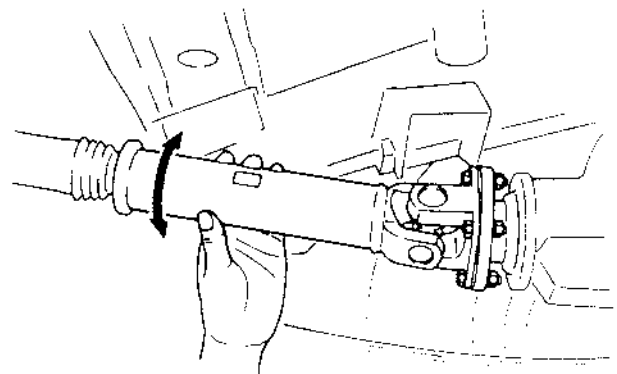


Fig. 15-9

## 15-5. TIGHTENING TORQUE

### Bolts & Nuts

Check following bolts and nuts for tightness and retighten them as necessary:

Fastening parts	N·m	kg·m (lb·ft)
Propeller shaft bolt & nut	23 – 30	2.3 – 3.0 (17.0 – 21.5)



*Fig. 15-10*

## 15-6. DISASSEMBLY

- Disassembling on propeller shaft yoke side.

1) Using snap ring pliers (Special tool), remove 2 circlips.

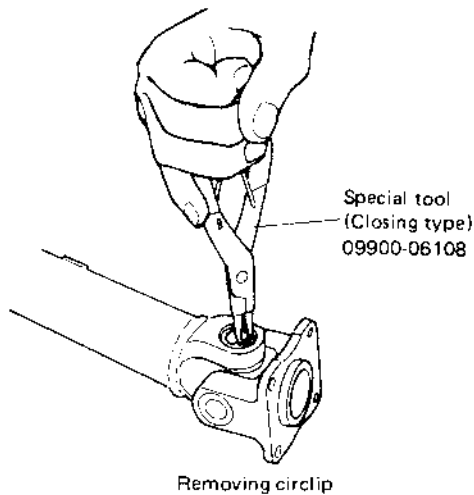
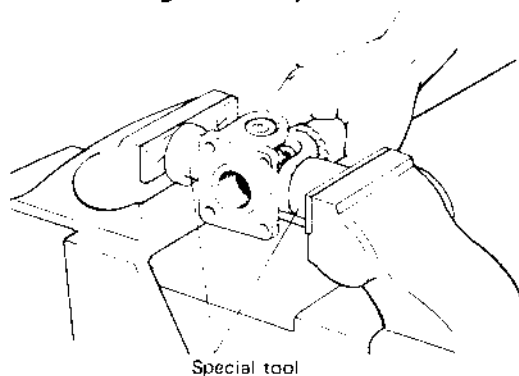


Fig. 15-11

2) Using universal joint assembler (Special tool 09926-48010), push spider bearing race out 3 – 4 mm (0.12 – 0.16 in.) from shaft yoke race.

### NOTICE:

Before pushing it out, apply penetrate lubricant between bearing race and yoke race.



3 – 4 mm (0.12 – 0.16 in.)

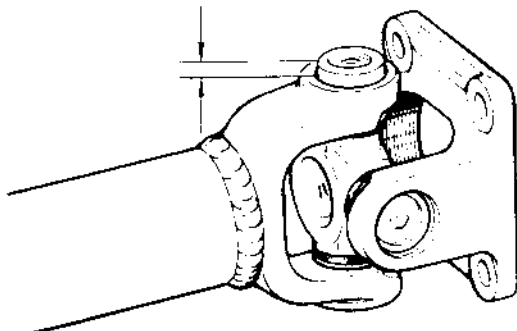


Fig. 15-12

3) Tapping yoke with a hammer, completely remove bearing race.

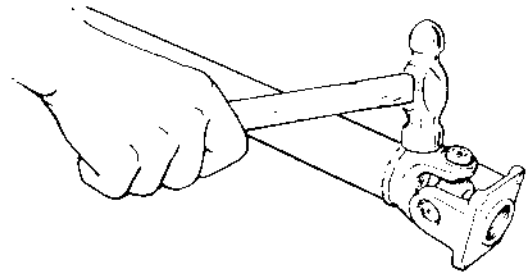


Fig. 15-13

4) Take out bearing race on the other side in the same way as in 2) and 3).

- Disassembling on flange yoke side

Push out bearing race on flange yoke side as described in 1) and 2), and then, holding bearing race in a vice, tap flange yoke and take out race. (Refer to the below figure.)

Remove bearing race on the opposite side in the same way.

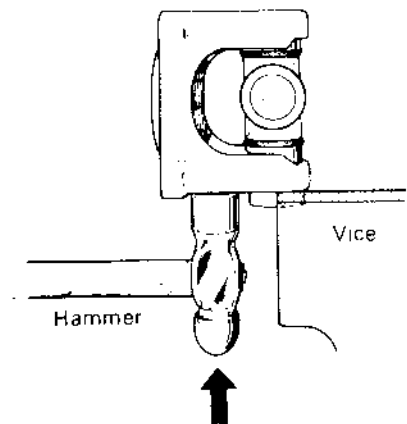


Fig. 15-14

### NOTICE:

- Take care not to lose rollers in spider bearing race when removing it.
- Fit removed bearings temporarily in spider so that they can be reinstalled in their original positions.

## 15-7. REASSEMBLY

### NOTICE:

- Make certain that rollers inside spider bearing race are all in place.
- Make sure to apply SUPER GREASE C (99000-25030) to spider bearing race.

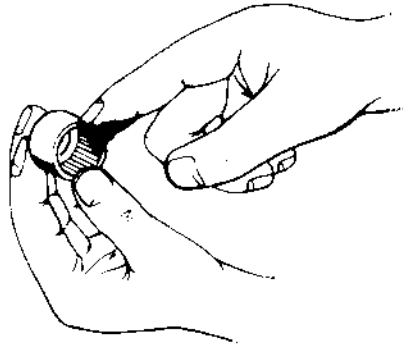


Fig. 15-15

### CAUTION:

In reassembly, be sure to use new circlips, spider and bearings. Reuse of circlips, spider and bearings once reassembled is prohibited.

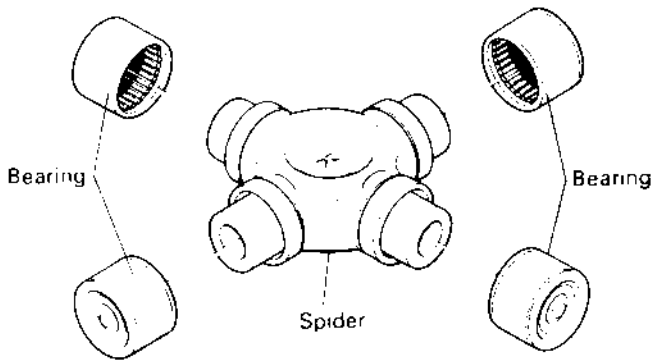


Fig. 15-16

- 1) Insert bearing race into yoke, tapping it with a hammer, until it is flush with yoke face. When doing this, insert spider into bearing race to prevent rollers in bearing race from coming out.

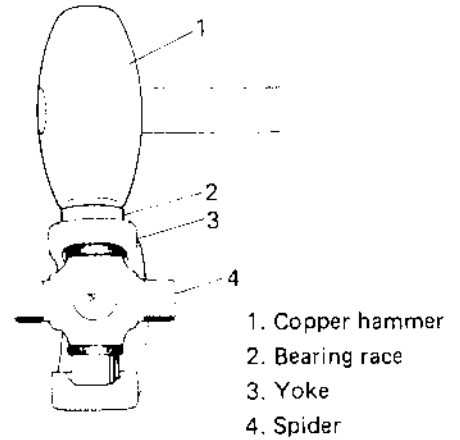


Fig. 15-17

- 2) Insert the other bearing race on the opposite side into yoke, tapping with a hammer until it is flush with yoke face.
- 3) Insert bearing races on the flange yoke side in the same way as described in 1) and 2) above.

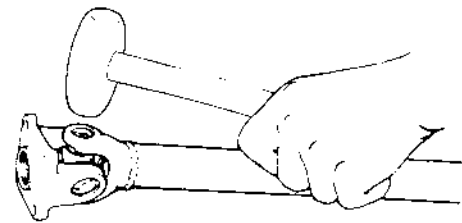


Fig. 15-18

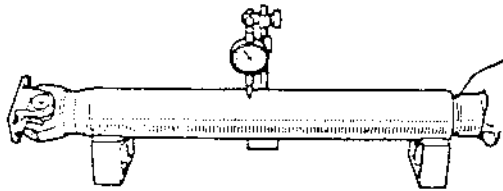
- 4) Place a metal plate on bearing races when tapping them in to avoid damaging yoke.
- 5) Securely fit 4 circlips to shaft and flange yolk.

### NOTICE:

- After reassembly, check to ensure that both shaft yoke and flange yoke move smoothly.
- Make sure that each circlip is fitted in the groove securely.

- 6) Inspect propeller shaft and flange yoke for damage, and propeller shaft for runout. If damage is found or shaft runout exceeds specifications, replace.

Runout limit	0.8 mm (0.031 in.)
--------------	-----------------------



*Fig. 15-19*



**SECTION 16**  
**DIFFERENTIAL**

**CONTENTS**

<b>16-1. GENERAL DESCRIPTION .....</b>	<b>16-2</b>
<b>16-2. REMOVAL .....</b>	<b>16-3</b>
<b>16-3. DISASSEMBLY .....</b>	<b>16-6</b>
<b>16-4. INSPECTION AND ADJUSTMENT OF COMPONENTS .....</b>	<b>16-7</b>
<b>16-5. REASSEMBLY .....</b>	<b>16-13</b>
<b>16-6. INSTALLATION .....</b>	<b>16-15</b>
<b>16-7. MAINTENANCE SERVICES .....</b>	<b>16-16</b>
<b>16-8. RECOMMENDED TORQUE SPECIFICATIONS .....</b>	<b>16-16</b>

## 16-1. GENERAL DESCRIPTION

The two axles, front and rear, are identical as far as the designs of pinion-and-gear drive and differential gearing are concerned. The major difference in this limited sense lies in the shape of the housing.

Each axle may be regarded as consisting, speaking roughly, of supporting parts (axle sleeves, differential housing and carrier case) and drive transmitting parts (bevel pinion and gear, differential gearing and live axle shafts). In the present section, only the bevel pinion and gear and differential gearing are taken up under the collective title of "differential."

The bevel gear drive is of hypoid design; pinion and gear have hypoid gear teeth. This means that the pinion is located slightly below the center of the bevel gear to permit the car body to be lowered in design, and that some wiping or sliding action occurs in tooth meshing between pinion and gear. Here lies the reason why use of hypoid gear oil is specified for the differential.

Four differential pinions are used in the differential case to qualify this gearing for heavy-duty "differential" drive. Thus, a total of 8 gears—a drive pinion, a crown gear, two side gears and four pinions—are inside the differential housing, all mounted on the differential carrier case bolted to the housing.

This differential is so constructed that the bevel pinion bearing preload is adjusted by tightening the bevel pinion nut to compress the spacer.

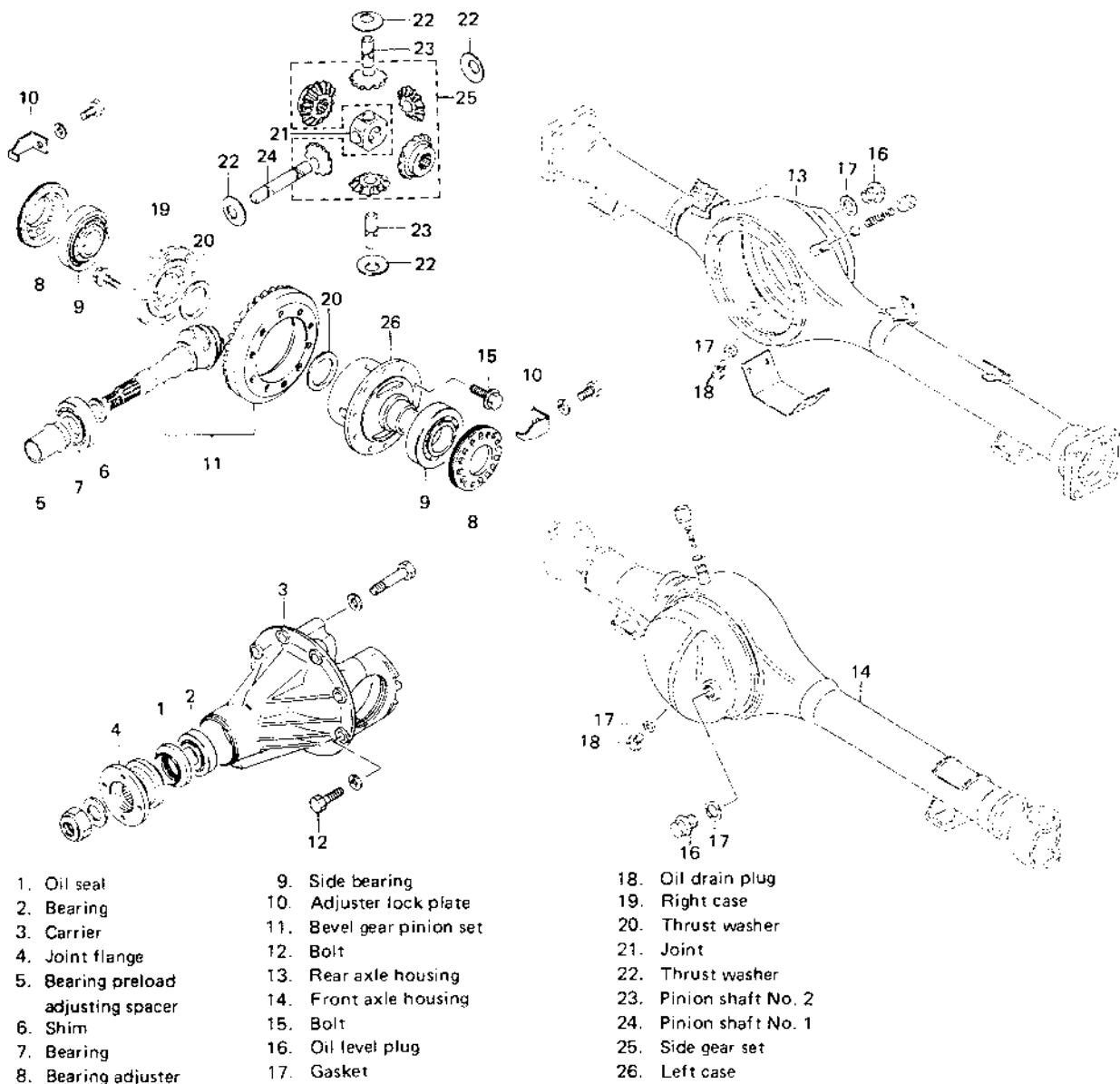


Fig. 16-1

## 16-2. REMOVAL

1. Loosen, but do not remove, wheel nuts of front or rear wheels, and raise car off the floor by jacking.  
Rest car steady on safety stands.
2. Drain out oil in differential housing by loosening drain plug.
3. Remove wheel nuts and take off wheels, front or rear. Each wheel has five wheel nuts.

### For Front Differential

After taking down front wheels, remove disc brake caliper with carrier.

### NOTICE:

Hang removed caliper with a wire hook or the like so as to prevent brake hose from bending and twisting excessively or being pulled.

Don't operate brake pedal with caliper removed.

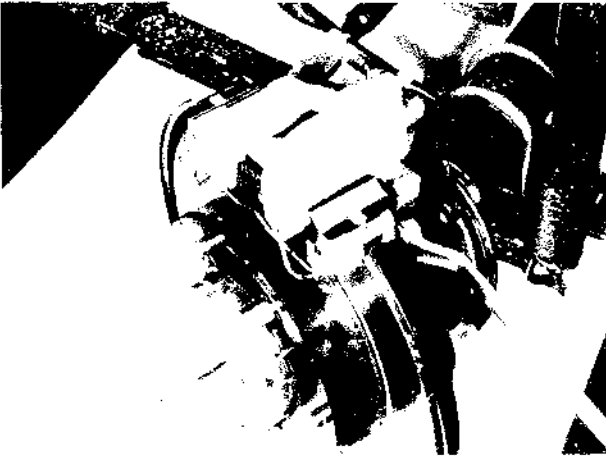


Fig. 16-2

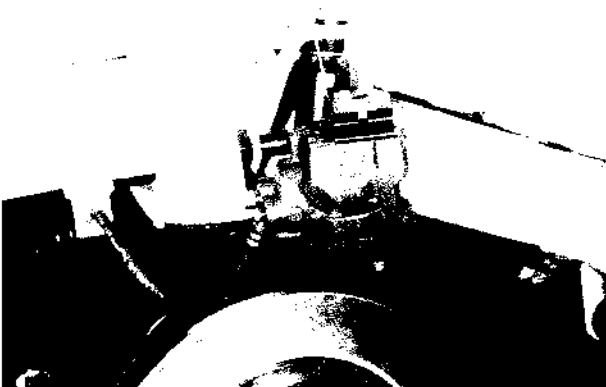


Fig. 16-3

At each tie rod end, remove nut and disconnect the end from steering knuckle using special tool

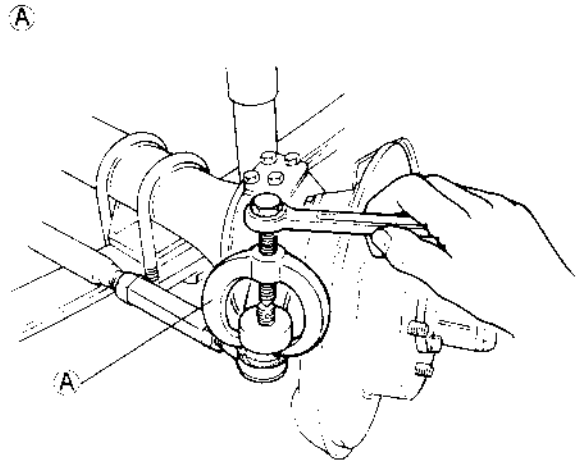


Fig. 16-4

(A) Special tool (Tie rod end remover 09913-65210)

Remove 8 oil seal cover securing bolts. From steering knuckle, take off felt pad, oil seal and seal retainer.



Fig. 16-5

Remove top and bottom kingpins from knuckle by removing 4 bolts securing each pin.

### NOTICE:

The removed top and bottom kingpins must be kept separated so as to prevent an error when putting them back in their place in reassembly.



Fig. 16-6

Draw out live axle shaft from axle housing.

**NOTICE:**

At this time, lower kingpin bearing sometimes falls off. So remove bearing while pulling off knuckle gradually.

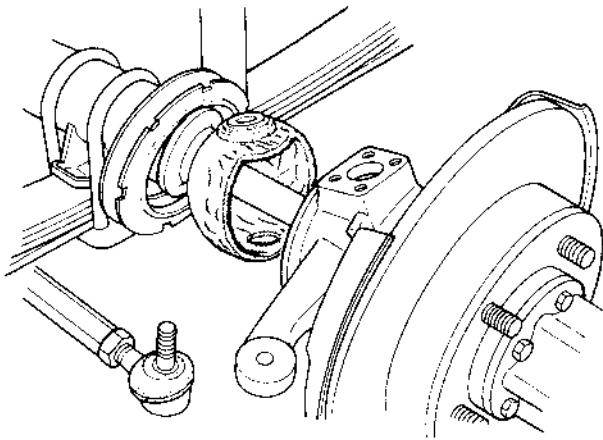


Fig. 16-7

At differential housing, disconnect propeller shaft by removing bolts securing flange yoke to companion flange. Remove 8 bolts holding fast differential carrier case to housing, and take down carrier assembly.



Fig. 16-8

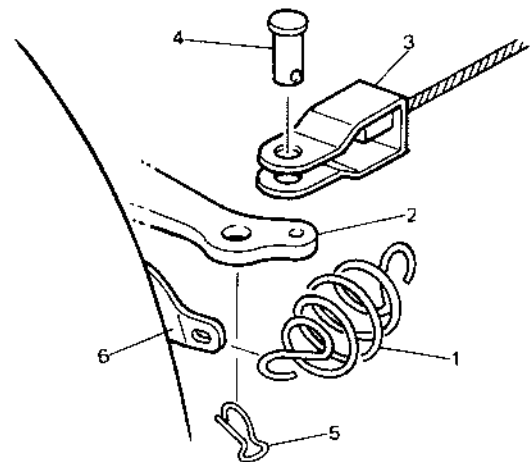
**For Rear Differential**

After taking down rear wheels, remove brake drums by using special tools.

**NOTICE:**

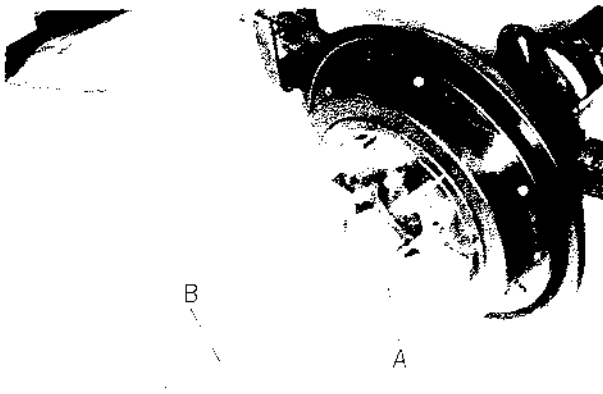
Before removing brake drum, check to ensure that parking brake lever is not pulled up.

To increase clearance between brake shoe and brake drum, remove parking brake shoe lever return spring ① and disconnect parking brake cable joint ③ from parking brake shoe lever ②. Remove parking brake shoe lever stopper plate.



- |   |                     |
|---|---------------------|
| 1. Parking brake shoe lever return spring | 4. Pin              |
| 2. Parking brake shoe lever               | 5. Clip             |
| 3. Parking brake cable joint              | 6. Brake back plate |

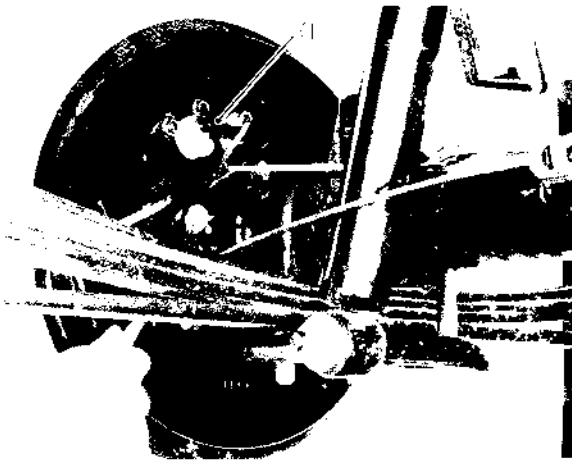
Fig. 16-9



**Fig. 16-9-1** (A) Special tool (Brake drum remover 09943-35511)  
 (B) Special tool (Sliding hammer 09942-15510)

Disconnect brake pipe from wheel cylinder. Have a small plug ready for use when disconnecting pipe. As pipe comes off the wheel cylinder, plug the pipe to prevent brake fluid from leaking out.

And remove 4 brake backing plate securing bolts.



**Fig. 16-9-2** ① Plug

Using special tools indicated below, draw out each live axle shaft with brake backing plate.



**Fig. 16-10** (A) Special tool (Rear axle remover 09922-66010)  
 (B) Special tool (Sliding hammer 09942-15510)

Disconnect propeller shaft as in the case of front axle, and detach and take down differential carrier case from housing by removing 8 bolts.



**Fig. 16-11**

### 16-3. DISASSEMBLY

Lock flange immovable by using special tool, and remove nut from the end of bevel pinion shank.

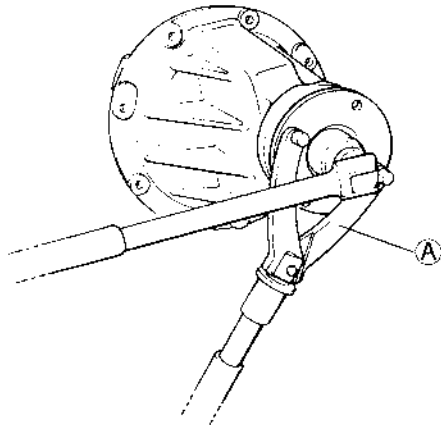


Fig. 16-12 (A) Special tool (Rotor holder 09930-40113)

Scribe marks on each cap bolted to the saddle portion of carrier case and holding down the side bearing. The marks are to identify caps. This means that there are right and left caps, so identified and so handled at the time of reassembly.

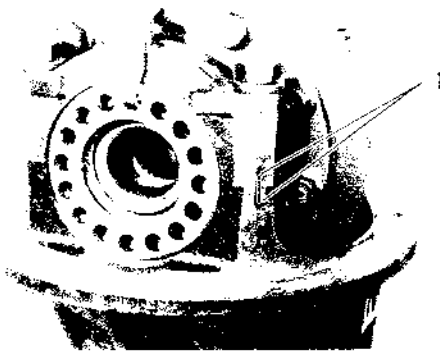


Fig. 16-13 (1) Scribed match marks

At each side, loosen bolts on bearing adjuster stopper, remove bearing cap securing bolts, and take off cap. Lift differential case assembly, complete with bevel gear, off the carrier.

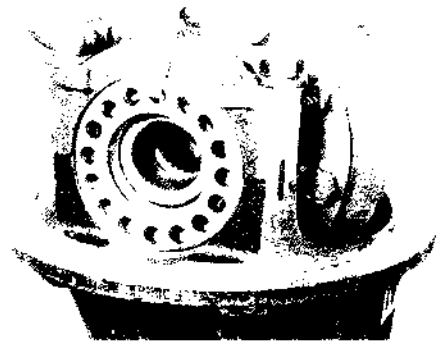


Fig. 16-14

Remove 10 bolts securing bevel gear to differential case, and separate gear from case.

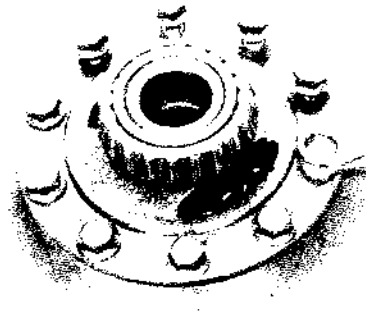


Fig. 16-15

There are 8 bolts fastening two differential case halves together. Remove these bolts to sever right-hand case half from left-hand one, and take off right-hand one.

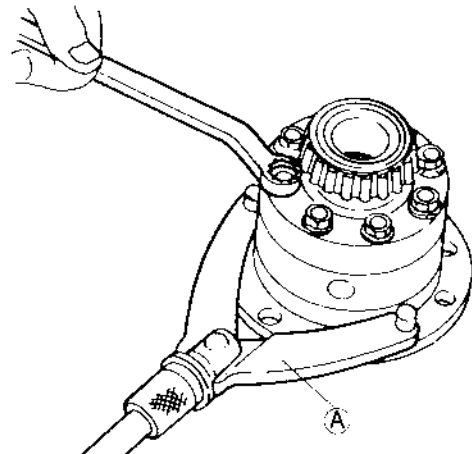


Fig. 16-16 (A) Special tool (Rotor holder 09930-40113)

Remove side gears, differential pinions and thrust washers.



Fig. 16-17

Using special tools indicated below, extract side bearing from each differential case half.

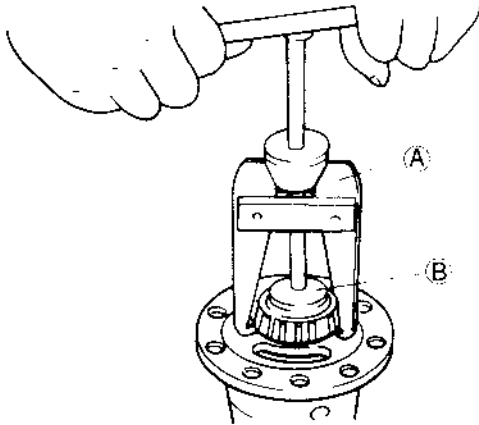


Fig. 16-18 (A) Special tool (Bearing puller 09913-60910)  
(B) Special tool (Side bearing removing jig 09913-85230)

Using puller and hydraulic press, remove inner race of bevel pinion bearing.

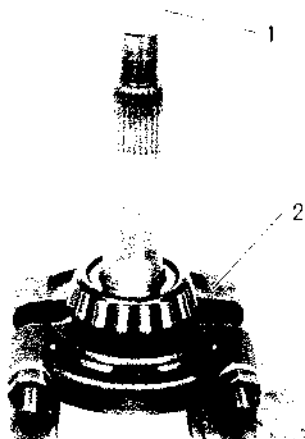


Fig. 16-18-1 ① Hydraulic press ② Puller

## 16-4. INSPECTION AND ADJUSTMENT OF COMPONENTS

### Side Gear Thrust Play

To check thrust play, assemble differential gearing and case, as shown in Fig. 16-19, fastening together two case halves by tightening securing bolts to prescribed torque. By comparing thrust play reading, taken as shown in Fig. 16-19, against thrust play indicated below, increase or decrease total thickness of thrust washers, which are located in two places, that is, on the inner side of each case half.

Side gear thrust play specification	0.12 – 0.37 mm (0.005 – 0.014 in)
-------------------------------------	--------------------------------------

Available thrust washer sizes (thickness)	0.9, 1.0, 1.1 & 1.2 mm (0.035, 0.039, 0.043 & 0.047 in)
---	--

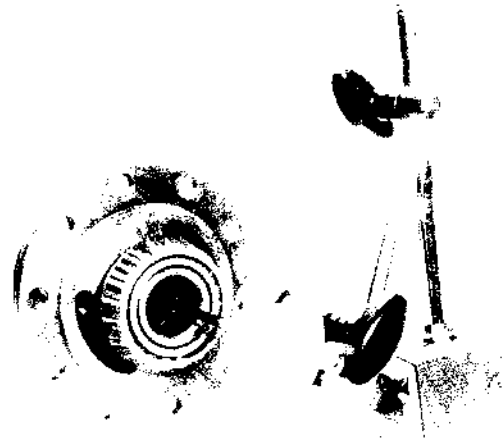


Fig. 16-19

## Determination of Shim Thickness for Bevel Pinion

Thickness of shims to be used on the bevel pinion varies from one vehicle to another on account of factors involved in machining and assembling. Thus, for each vehicle, the thickness of shims necessary for locating pinion in correct position (for producing a proper backlash in the mesh between pinion and gear) must be determined anew at the time of reassembly.

In order to facilitate this determination, a two-piece dummy tool (special tool) is made available. Following procedure is based on use of this tool and supposes that pinion dummy (one of the two pieces) is set in carrier, without any shims, as shown in Fig. 16-20.

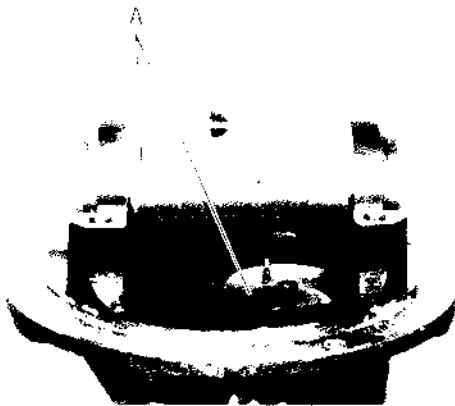


Fig. 16-20 (A) Special tool (Bevel pinion mounting dummy 09926-78310)

- 1) Set dial indicator on dummy, letting the indicator spindle protrude 5 to 6 mm from the bottom of dummy as shown in Fig. 16-21-1.

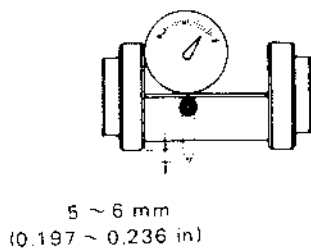


Fig. 16-21-1

- 2) Feed dummy pinion with bearings into the carrier, positioning it properly, and install joint flange.

And then tighten bevel pinion nut until specified starting torque of bevel pinion is obtained. Refer to item 2) and 3) of "Bevel Pinion Bearing Preload Adjustment" described on next page.

### NOTICE:

In this case, fit only bearings to bevel pinion. Don't fit spacer.

- 3) Rest dummy with dial indicator on carrier and pinion dummy, and set dial indicator to zero.

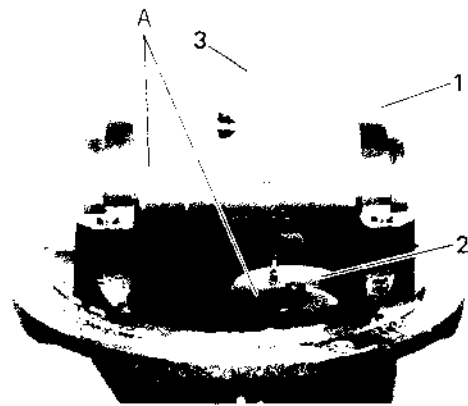


Fig. 16-21-2 1. Dummy 2. Pinion dummy 3. Dial indicator

- 4) Referring to Fig. 16-21-3, note that three dimensions are involved: "a" "b" and "c". The value of "b" is unknown, and is to be determined now for calculating the required thickness of shims. The values of "a" and "c" are given: the sum, "a" + "c", is 94 mm, which is indicated on the dummy tool.

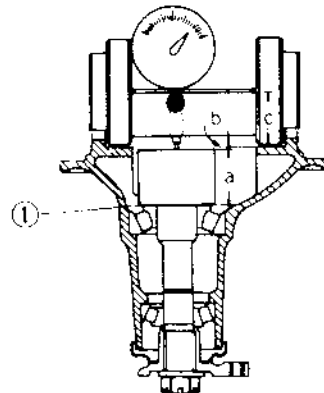


Fig. 16-21-3



Rest dummy with dial indicator on surface plate, and the dial indicator pointer may have deflected from "0" mark to show a certain value; read this value, which is "b".

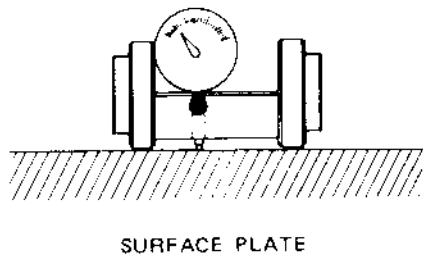


Fig. 16-21-4

Add this reading to 94 mm (= "a" + "c") and, from the sum, subtract the value marked on bevel pinion. The remainder is required shim thickness:  $(94 + "b") - \text{marked value} = \text{required shim thickness}$

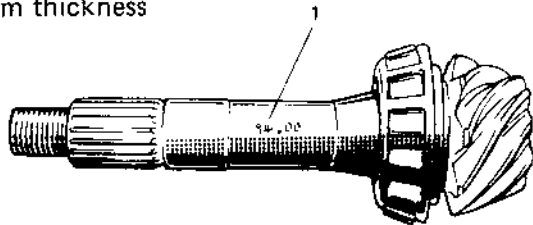


Fig. 16-22 1. Marked value

5) Shim stock is available in twelve selective thicknesses. Select one or two shim(s) from the below to obtain the closest thickness to above required thickness, and insert selected shim piece(s) into clearance indicated as Fig. 16-21-3—①.

Sizes of shims for bevel pinion	1.00, 1.03, 1.06, 1.09, 1.12, 1.15, 1.18, 1.21, 1.24, 1.27, 1.30 & 0.3 mm
	{ 0.039, 0.041, 0.042, 0.043, 0.044, 0.045, 0.046, 0.047, 0.048, 0.049, 0.050 & 0.012 in. }

### Bevel Pinion Bearing Preload Adjustment

The bevel pinion, as installed in normal manner in carrier, is required to offer a certain torque resistance when checked by using prescribed preload adjuster (special tool Ⓐ) as shown in Fig. 16-23. This resistance is a "preload," which is due to the tightness of the two tapered roller bearings by which the pinion is held in the carrier. And this tightness is determined primarily by tightening torque of bevel pinion nut. Adjust preload of bevel pinion bearings as follows.

1) Install pinion bearings, spacer, bevel pinion, oil seal and universal joint flange to differential carrier.

At this time, be sure to apply gear oil to bearings lightly and grease to oil seal lip.

2) Tighten bevel pinion nut by hand, and install special tool to universal joint flange.

3) After turning pinion several times, tighten pinion nut gradually, while checking pinion starting torque with spring balance, and stop tightening when starting torque reaches specification given below.

4) Caulk bevel pinion nut to prevent it from loosening.

### NOTICE:

Bevel pinion bearing preload is adjusted by tightening bevel pinion nut to crush spacer. Therefore, be sure to use a new spacer for adjustment and tighten pinion nut step by step and check for starting torque (preload) as often as tightening to prevent over crushing of spacer. If exceeds specification given below during adjustment, replace spacer and repeat preload adjustment procedure. Attempt to decrease starting torque (preload) by loosening pinion nut will not do.

The below data are not tightening torque of pinion nut but pinion bearing preload.

Pinion bearing preload	9.0 – 17.0 kg-cm (7.8 – 14.7 lb-in)
Starting torque (When using special tool)	1.8 – 3.4 kg (4.0 – 7.5 lb)

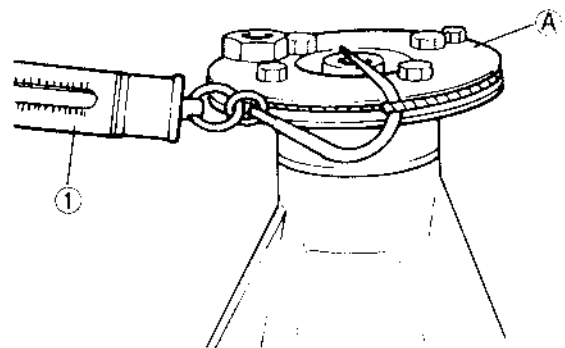


Fig. 16-23 ① Spring balance  
Ⓐ Special tool (Differential gear preload adjuster 09922-75221)

### Bevel Gear Backlash Adjustment

Backlash between bevel gear and pinion is checked as shown in Fig. 16-24. Note that differential case assembly is mounted in the normal manner, and fastened down by tightening the side bearing cap bolts to 1.0 – 2.0 kg-m (7.5 – 14.0 lb-ft). At this time, screw in each adjuster till it contacts bearing outer race so that outer race is prevented from inclining. The dial indicator spindle is pointed squarely to “heel” on drive side (convex side) of gear tooth. Hold bevel pinion rigidly, and turn gear back and forth.

The dial indicator reading, which is bevel gear backlash, must be within this range:

Bevel gear backlash	0.10 – 0.15 mm (0.004 – 0.006 in.)
---------------------	---------------------------------------

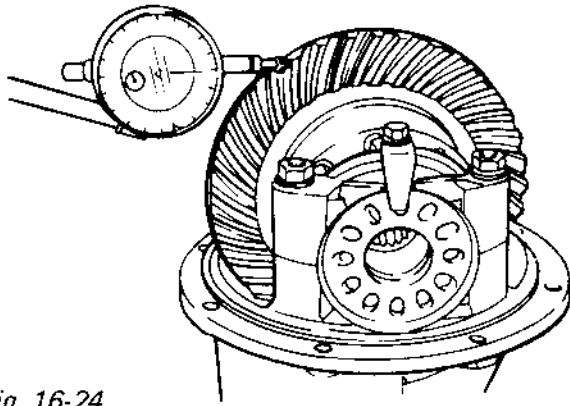


Fig. 16-24

To increase or decrease backlash for adjustment, displace bevel gear toward or away from pinion by running in one adjuster and running out the other adjuster by equal amount.

Turning the adjuster one notch changes backlash by about 0.05 mm (0.002 in.).

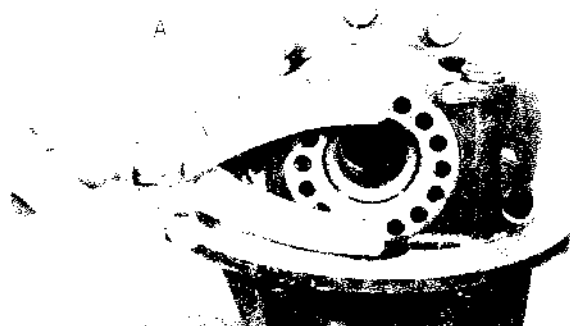
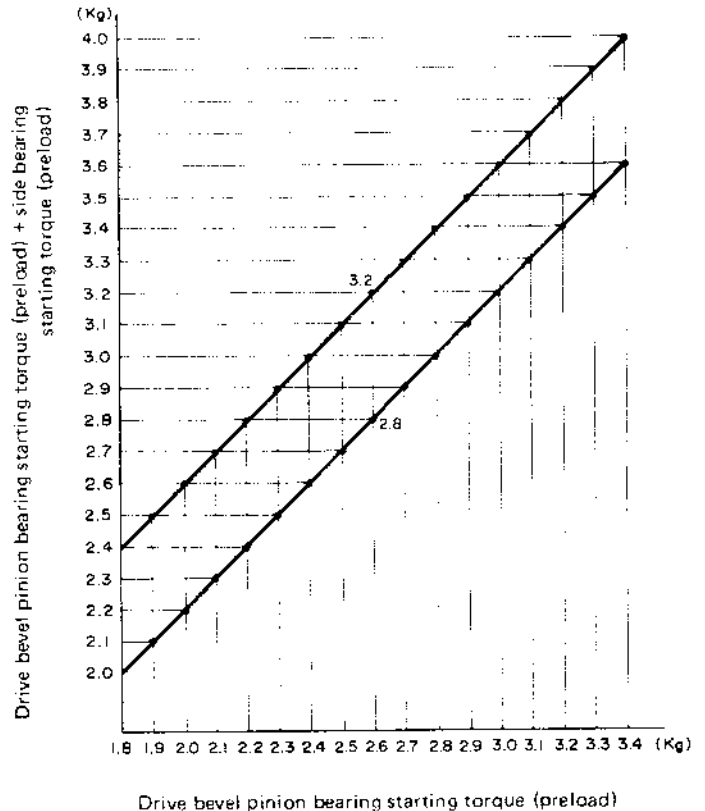


Fig. 16-25 (A) Special tool (Rotor holder  
09930-40113)

### CAUTION:

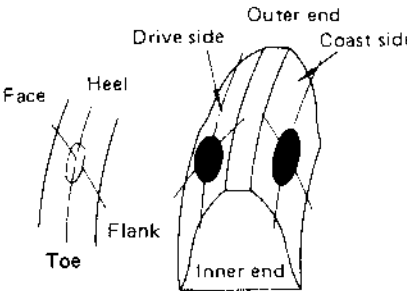


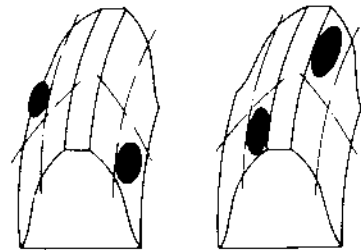
- Adjust preload on side bearing during back-lash adjustment: mount special tool on drive bevel pinion as shown in Fig. 16-23 and measure using spring balance ①. If reading at the instant bevel gear starts moving is within the range given below, side bearing preload is acceptable. Referring to the graph, for example, when the drive bevel pinion bearing preload measured as shown in Fig. 16-23 is 2.6 kg (5.73 lb), drive bevel pinion bearing preload (kg) + bevel gear side bearing preload (kg) should be 2.8 – 3.2 kg (6.17 – 7.05 lb).
- Upon completion of this adjustment, be sure to tighten bearing cap bolts to 7.0 – 10.0 kg-m or 51.0 – 72.0 lb-ft.



### Pinion-to-gear Tooth Contact Pattern Check and Adjustment

In addition to proper backlash, proper tooth contact must be secured in the mesh of bevel pinion and gear, so that there will be no "gear noise" coming from the axle and that the hypoid teeth will not be overstressed in transmitting drive.

After the specified amount of backlash has been secured, check the pinion and gear for tooth contact by "rolling" contact patterns in a manner consistent with the standard shop practice: use a red lead paste to paint ten teeth, both drive side and coast side, of the gear, turn the gear back and forth by hand while holding the pinion in a "braking" manner, and examine the contact patterns in reference to the following chart:

	Contact patterns	Diagnosis, and what to do
Normal contact pattern		<p>Contact is roughly centered and somewhat more displaced toward toe than toward heel on both drive side (concave) and coast (convex) side.</p>
Patterns due to improper shim adjustment		<p>High contact: Contact is on heel (drive side) and on toe (coast side). This condition means that the pinion is too far back and must be brought forward by increasing its shim thickness used in "mounting distance" adjustment.</p>
		<p>Low contact: Contact is on toe (drive side) and on heel (coast side). This condition means that the pinion is too far out from the carrier and must be backed away by decreasing its shim thickness.</p>
Pattern due to defective parts		<p>These contact patterns indicate that the "offset" of differential carrier is too much or too little. The remedy is to replace the carrier with a new one.</p>

	Contact patterns	Diagnosis, and what to do
Patterns due to defective parts		<p>These contact patterns, located on toe or heel on both drive and coast sides, mean that 1) both pinion and gear are defective, 2) carrier is not true and square, or 3) gear is not properly seated on differential case. The remedy is to replace the defective member.</p>
		<p>Irregular patterns: If the pattern is not oval, it means that bevel gear is defective. High or low spots on tooth surfaces or on the seat of bevel gear are the cause of irregular patterns appearing on some teeth. The remedy is to replace the pinion and-gear set and, if the seat is defective, so is differential case.</p>

**CAUTION:**

When applying red lead paste to teeth, be sure to paint tooth surfaces uniformly. The paste must not be too dry or too fluid.

## 16-5. REASSEMBLY

Reverse disassembly procedure for reassembly, noting the following.

### NOTICE:

Bevel pinion and bevel gear are supplied as a set. Even when only bevel pinion or bevel gear replacement is necessary, be sure to replace both as a set.

### Differential Pinion Shaft (Shorter)

When installing shaft into differential case and pinion, insert its "A" side into pinion joint.

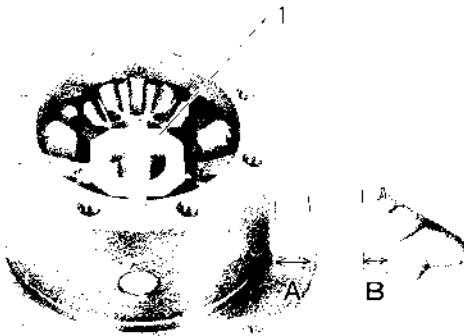


Fig. 16-26 ① Pinion joint  
 $A > B$  ("A" is longer than "B".)

### Drive Bevel Gear Bolts

Bolts securing bevel gear to differential case are subject to shear stress since drive is transmitted by these bolts from gear to case. For this reason, they are special bolts made from chrome steel and must never be replaced by common bolts.

When mounting gear onto case, be sure to apply **THREAD LOCK CEMENT SUPER 1333B** (99000-32020) to these bolts before running them in.

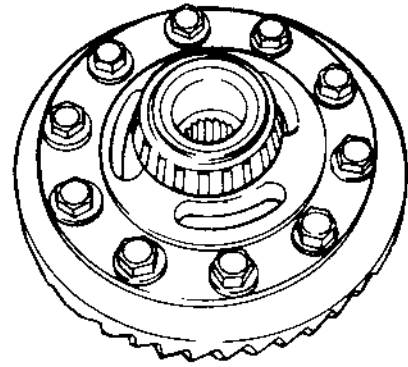


Fig. 16-26-1

### Differential Side Bearings

Press-fit these bearings into differential case by using special tool. Driving the bearing into case is not permitted.

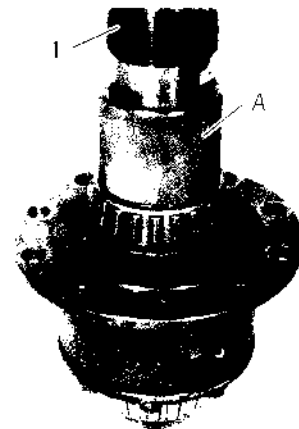


Fig. 16-27

① Press

Ⓐ Special tool (Bearing installer  
09940-53111)

**Bevel Pinion Bearings**

A press must be used to install two tapered roller bearings on bevel pinion. Outer races are press-fitted into the differential carrier and inner races onto the pinion.

**NOTICE:**

When replacing bevel pinion bearings, check to ensure that gear side and flange side bearings are the same marker's products.

1) For outer race of flange side bearing, use special tool as shown below.

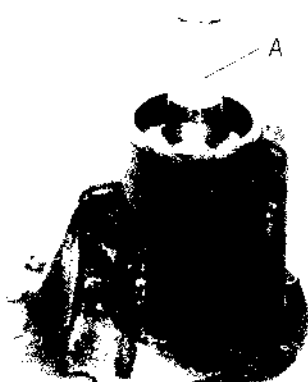


Fig. 16-28 A Special tool (Bearing installer 09913-75510)

2) For outer race of gear side bearing, use special tools.

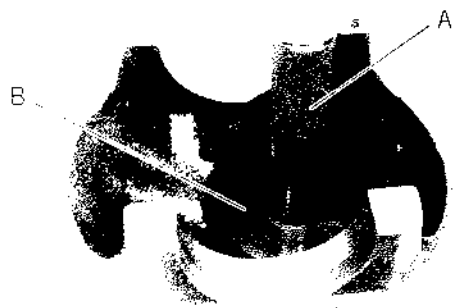


Fig. 16-29 A Special tool (Bearing installer attachment 09924-74510)  
B Special tool (Bearing installer 09926-68310)

3) After installing proper bevel pinion shim(s), press-fit inner race to bevel pinion using special tools.



A Special tool (Bearing installer 09925-18010)

B Special tool (Bearing installer 09940-53111)

Fig. 16-30

4) After installing bevel pinion, spacer, bearings and universal joint flange to carrier and carrying out "bevel pinion bearing preload adjustment" as described previously, caulk bevel pinion nut to prevent it from loosening.



Fig. 16-30-1

### Side Bearings Caps

When putting on side bearing caps, be sure to discriminate the right-hand cap from the left-hand one by referring to match marks scribed at the time of disassembly.

Then, after carrying out "Bevel gear backlash adjustment" as described on p. 16-10 torque cap bolts to specification.

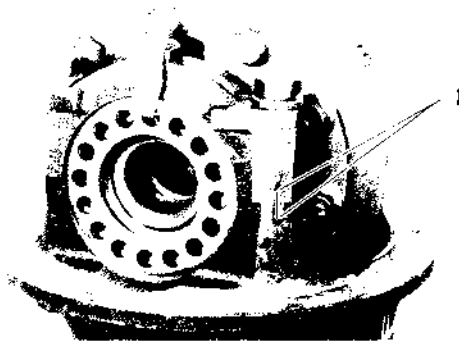


Fig. 16-31 ① Scribed match marks

## 16-6. INSTALLATION

Reverse removal procedure for installation, noting the following.

### Differential

Before installing differential ass'y to axle housing, clean mating surfaces of differential carrier and housing and apply sealant to them.

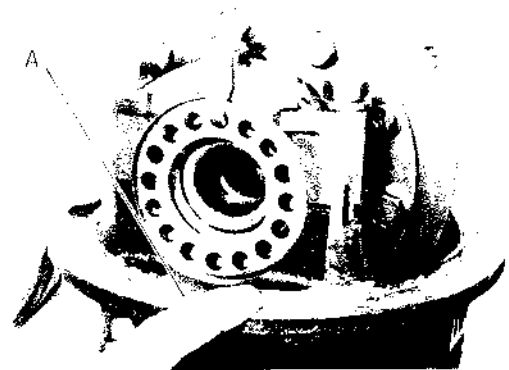


Fig. 16-32 Ⓐ Sealant (SUZUKI BOND NO. 1215 99000-31110)

### Front Axle Shaft and Steering Knuckle

For installation them, refer to "Front Suspension Installation" in SECTION 17 of this manual.

### Rear Brake Drum

For installation of rear brake drum, refer to "Rear Brake Installation" in SECTION 19 of this manual.

### Differential Gear Oil

Refill differential housing with new specified oil. Refer to "MAINTENANCE SERVICE" in this section for refill.

### Brake Circuit Air Purging

If brake pipe (right & left) was disconnected from wheel cylinder as in Fig. 16-9-2, make sure to purge air out of brake circuit. Refer to section 19. BRAKES for "air purging" operation. Then check to ensure that joint seam of pipe is free from oil leak.

## 16-7. MAINTENANCE SERVICES

### Inspection

Inspect differential and differential housing for evidence of oil leakage.

Oil level is checked by means of its oil level plug. Refer to p. 1-17 for level inspection.

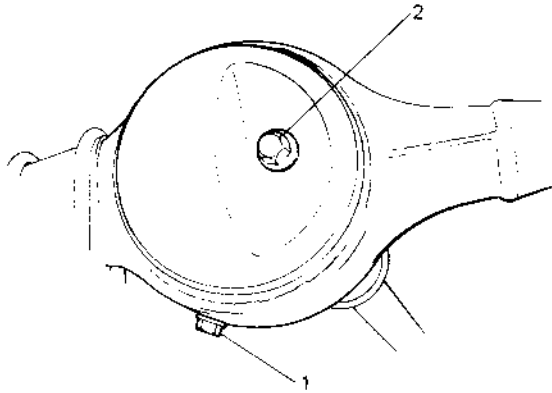


Fig. 16-33 ① Drain plug  
② Oil level & filler plug

### Oil Change

- 1) Remove oil drain plug and drain oil.
- 2) Reinstall drain plug and tighten it to specified tightening torque.
- 3) Remove oil level & filler plug and fill differential housing with new specified oil.

Differential oil specification	Hypoid gear oil SAE 80W-90, 75W-80 or 75W-90	
Oil capacity	Front	2.0 litres (4.2/3.5 US/Imp pt.)
	Rear	1.5 litres (3.2/2.6 US/Imp pt.)

It is highly recommended to use SAE 75W-90 gear oil.

For viscosity chart, refer to P.1-17.

- 4) Reinstall oil level & filler plug and tighten it to specified tightening torque.

## 16-8. RECOMMENDED TORQUE SPECIFICATIONS

Fastening parts	Tightening torque		
	N-m	kg-m	lb-ft
Side bearing cap bolt	70 – 100	7.0 – 10.0	51.0 – 72.0
Drive bevel gear bolt	80 – 90	8.0 – 9.0	58.0 – 65.0
Differential case bolt	37 – 45	3.7 – 4.5	27.0 – 32.5
Side bearing adjuster lock bolt	9 – 14	0.9 – 1.4	7.0 – 10.0
Differential carrier bolt	18 – 28	1.8 – 2.8	13.5 – 20.0
Oil level & filler plug	35 – 50	3.5 – 5.0	25.5 – 36.0
Oil drain plug	40 – 70	4.0 – 7.0	29.0 – 50.5



# SECTION 17

## SUSPENSION

### CONTENTS

17-1. FRONT SUSPENSION .....	17-2
17-2. REAR SUSPENSION .....	17-15
17-3. MAINTENANCE SERVICES .....	17-20
17-4. RECOMMENDED TORQUE SPECIFICATIONS .....	17-26
17-5. FRONT FREE WHEELING HUB (OPTIONAL) .....	17-27

#### NOTICE:

- All suspension fasteners are an important attaching part in that it could affect the performance of vital parts and systems, and/or could result in major repair expense. They must be replaced with one of the same part number or with an equivalent part if replacement becomes necessary. Do not use a replacement part of lesser quality or substitute design. Torque values must be used as specified during reassembly to assure proper retention of this part.
- Never attempt to heat, quench or straighten any suspension part. Replace it with a new part, or damage to the part may result.
- The leaf spring number or shape shown in this manual may differ from the car being actually serviced, depending on specification.

## 17-1. FRONT SUSPENSION

### GENERAL DESCRIPTION

The front suspension consists of the double-acting shock absorbers, stabilizer bar, semi-elliptical leaf springs, axle housing, etc. as shown below.

The Barfield universal joints are used in the front axle to enable the axle shafts to drive the front wheels while allowing the wheels to be steered. This type of joint provides for a larger steering angle range and, what is more important, constant-velocity drive to the wheel.

If a single two-yoke (or Hooke's) universal joint is used to connect the live axle shaft to the wheel on each side of the front end, the wheels will run with the same speed, but not with the same constant velocity, as that of the axle shafts when the wheels are turned around their kingpins for steering action. The barfield joint transmits drive without varying the angular velocity of drive.

The Barfield joint is enclosed by the knuckle, which is shaped integral with the knuckle arm, and has a two-piece kingpin, namely, upper and lower kingpins.

The end of the dead axle sleeve is in the shape of dish. This dish is rotatably fitted into the knuckle structure to form a flexible connection, the sliding clearance between the two being sealed with a felt packing (against road dust and mud) and also with an oil seal (against the oil inside). The upper and lower kingpins, bolted to the knuckle extend into the knuckle and, inside, are held by the dish-like inner case through tapered roller bearings.

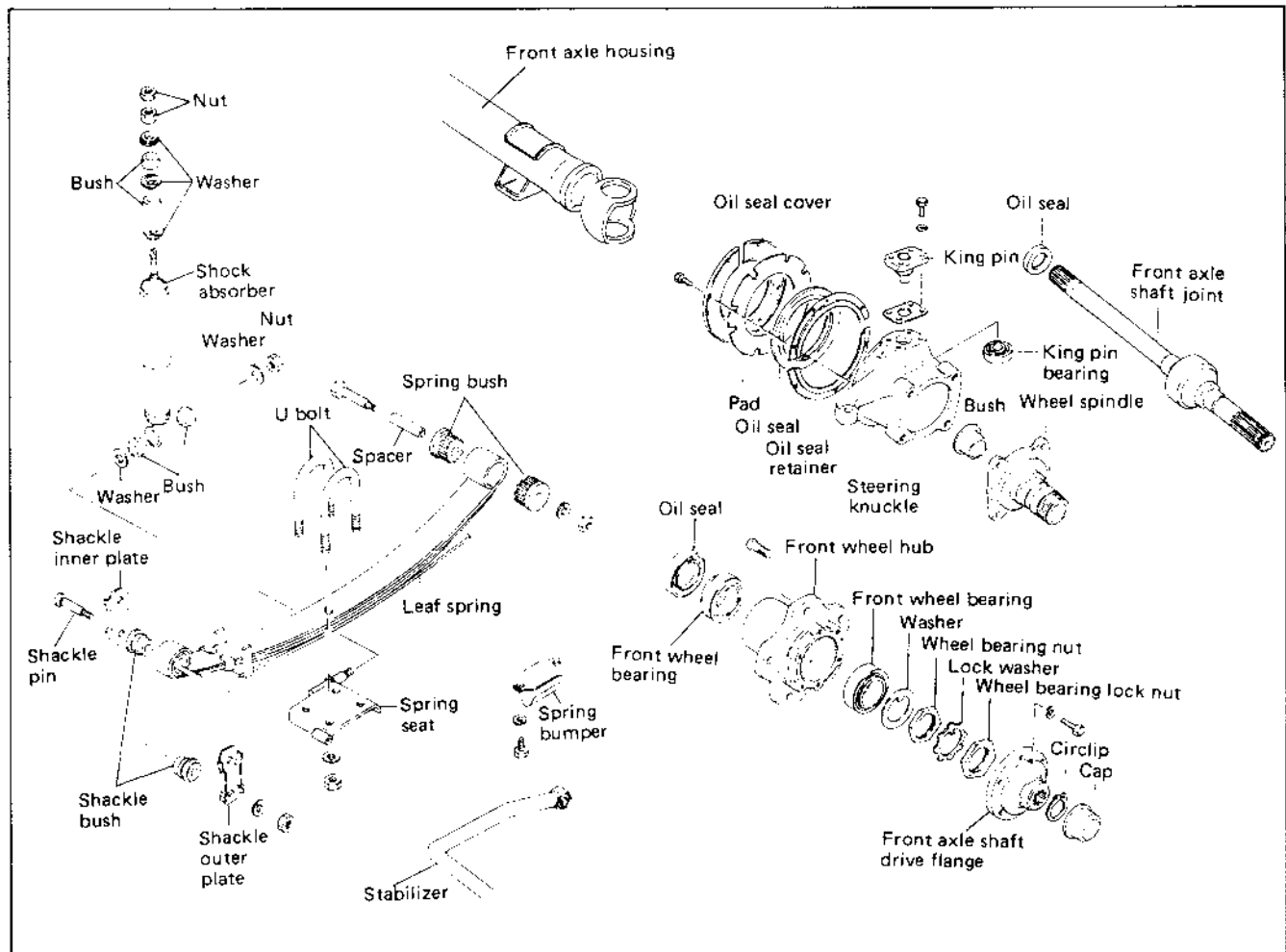
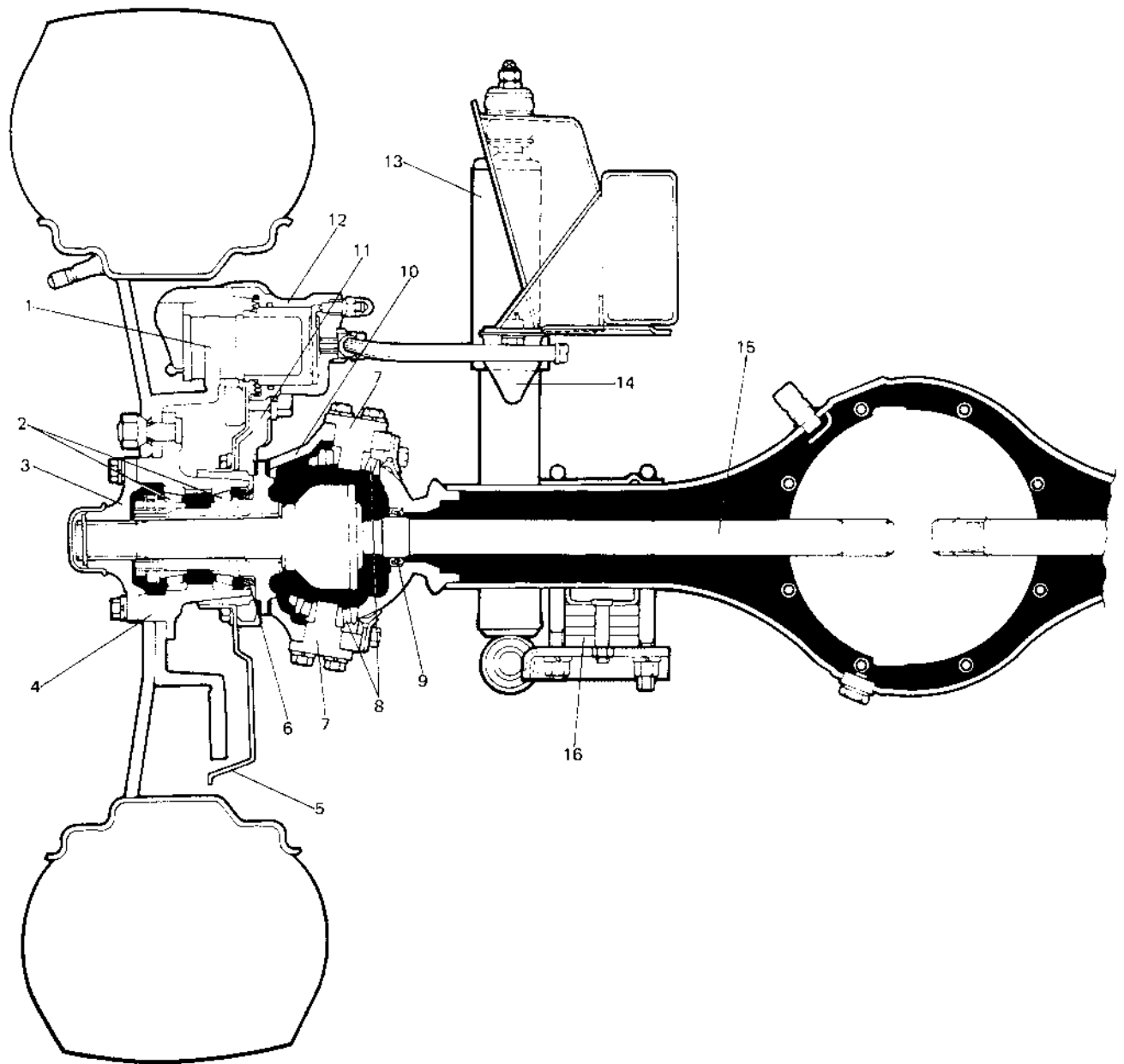


Fig. 17-1-1



- |                            |                        |
|----------------------------|------------------------|
| 1. Front brake disc        | 9. Oil seal            |
| 2. Wheel bearing           | 10. Steering knuckle   |
| 3. Axle shaft drive flange | 11. Disc brake holder  |
| 4. Wheel hub               | 12. Disc brake caliper |
| 5. Dust cover              | 13. Shock absorber     |
| 6. Oil seal                | 14. Spring bumper      |
| 7. King pin                | 15. Axle shaft joint   |
| 8. King pin bearing        | 16. Leaf spring        |

Fig. 17-1-2

### BARFIELD JOINT CONSTRUCTION AND OPERATION

The major parts of the Barfield joint are the outer race (integral with wheel spindle, to which the wheel disc is splined), inner race (splined to the live axle shaft), six steel balls disposed between the two races, and cage (holding the steel balls in a single row lying in a plane).

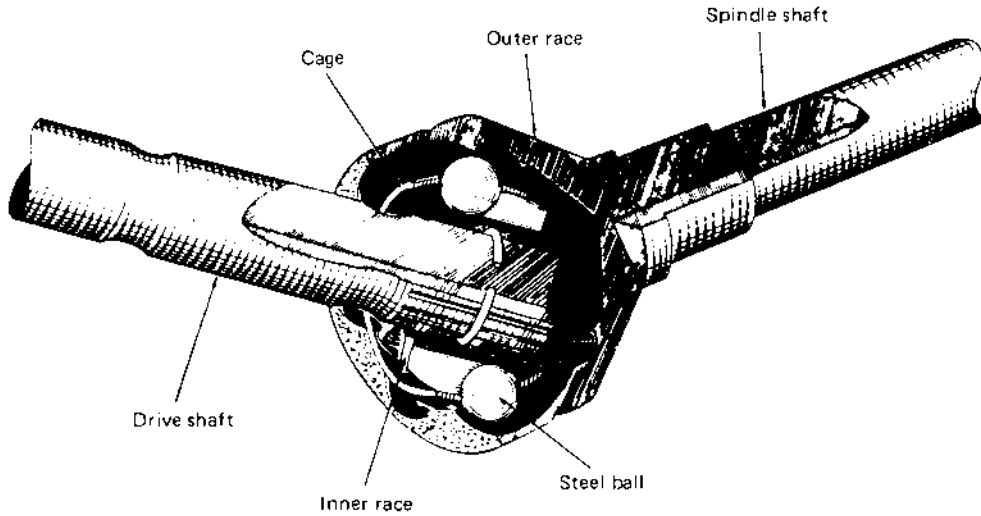


Fig. 17-1-3

The balls are fitted in two groups of raceways; one group is on the outer race and the other group on the inner race. Each ball is in its own raceways as if it were locked between the two races in the direction of rotation. The outer race with its wheel spindle is capable of angling and, when it so angles with respect to the axis of axle shaft, the row of steel balls angles just half as much, that is, the plane including this row tilts by an angle equal to one-half of the spindle angle. This relationship is illustrated in Fig. 17-1-4.

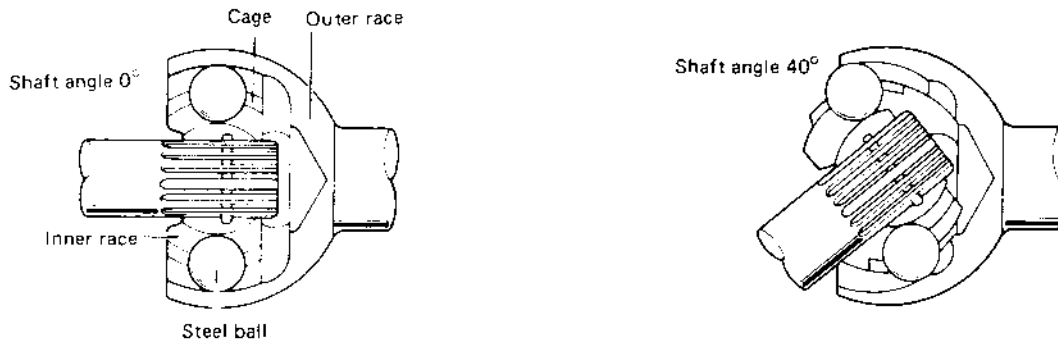


Fig. 17-1-4

## REMOVAL

### Shock Absorber

The shock absorber is non-adjustable, non-refillable, and cannot be disassembled.

The only service the shock absorber requires is replacement when it has lost its resistance, is damaged, or leaking fluid.

1. Hoist car.
2. Loosen lower and upper mounting nuts and remove shock absorber.

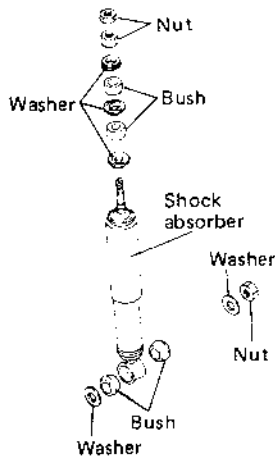


Fig. 17-1-5

### Leaf Spring

1. Raise car. In this operation, garage jack or hoist must not be positioned against front suspension related parts. When garage jack is used, place safety stands under chassis to support raised body.
2. Remove front wheel.
3. Remove stabilizer bolt.
4. Remove U-bolt nuts.
5. Remove shackle nuts and leaf spring nut.

### NOTICE:

Removal of leaf spring causes axle housing to hang. Support it with safety stand to prevent it from damaging universal joint of propeller shaft and others.

6. Pull out leaf spring bolt and remove leaf spring from shackle pin.

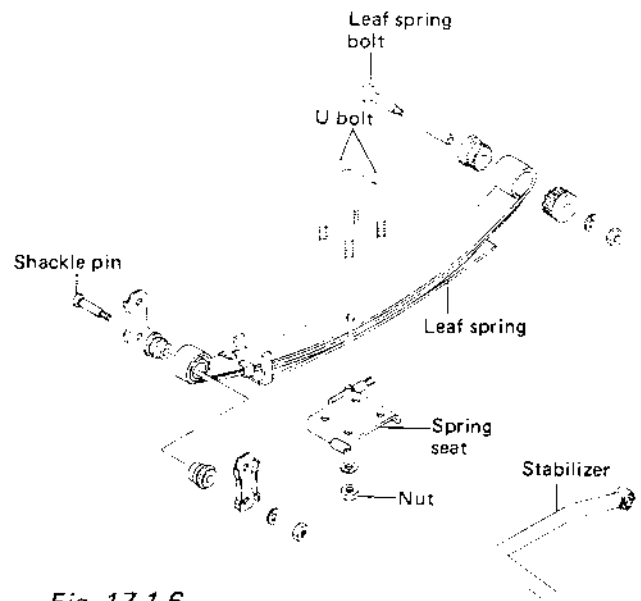


Fig. 17-1-6

### Stabilizer

1. Hoist car.
2. Remove stabilizer bolts.
3. After removing stabilizer mount bush bracket bolts, remove stabilizer.

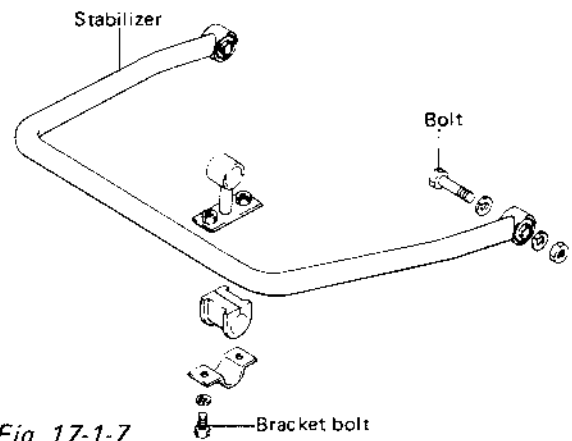


Fig. 17-1-7

### Front Wheel Hub & Bearing

1. Loosen the five nuts securing the wheel.  
Raise the front end by jacking.  
Rest the machine steady on safety stands.
2. Remove the five nuts and take off the wheel.

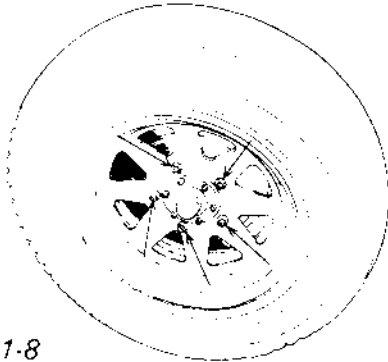


Fig. 17-1-8

3. Remove the caliper with carrier by loosening carrier bolts.

#### NOTICE:

Hang removed caliper with a wire hook or the like so as to prevent brake hose from bending and twisting excessively or being pulled.  
Don't operate brake pedal with caliper removed.

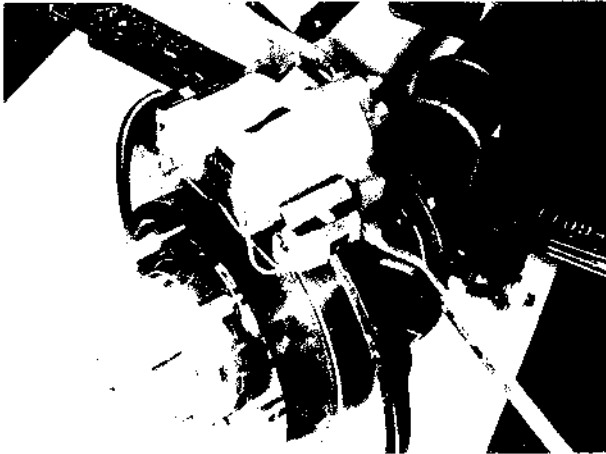


Fig. 17-1-9

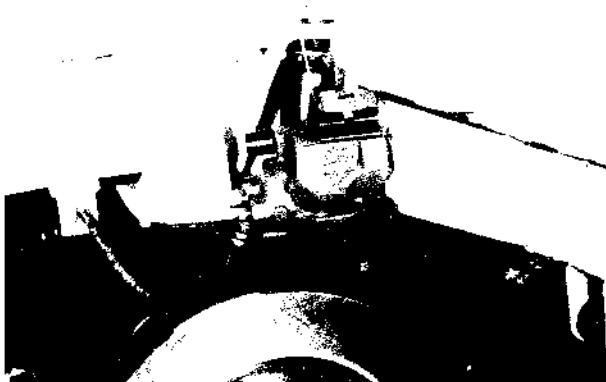


Fig. 17-1-10

4. Remove brake disc.

#### NOTICE:

If brake disc can not be removed by hand, use 8 mm bolts as shown below.

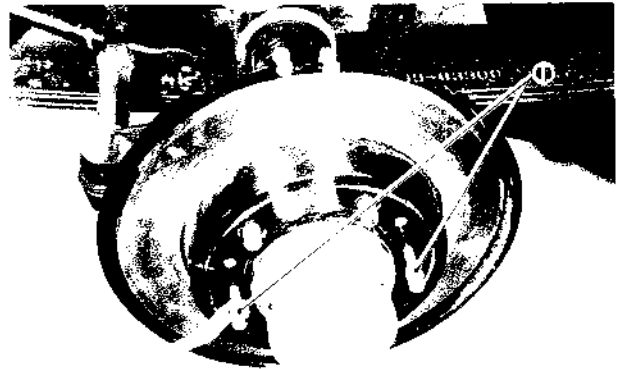


Fig. 17-1-11 1. 8 mm bolt

[For car equipped with free wheeling hub]

5. Remove free wheeling hub cover and circlip.

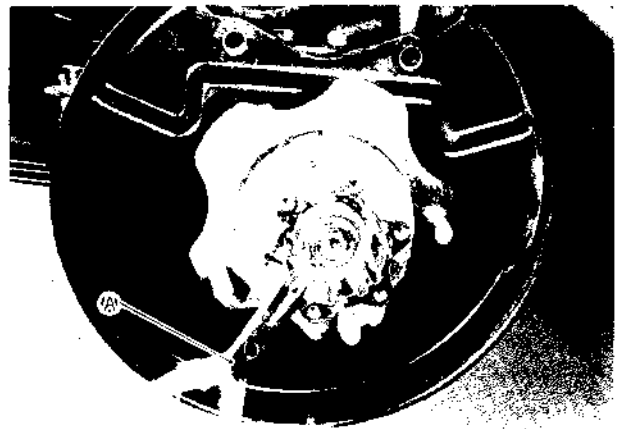


Fig. 17-1-12-1 (A) Circlip remover (09900-06107)

6. Remove free wheeling hub body.

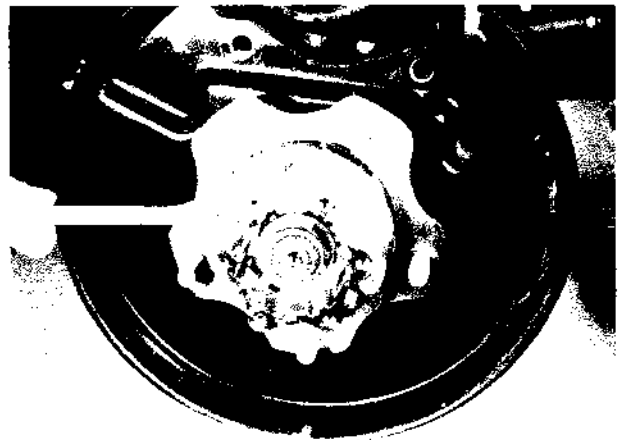


Fig. 17-1-12-2

[For car not equipped with free wheeling hub]

5. Remove the front axle shaft cap.
6. Remove the circlip retaining the front axle shaft drive flange on front drive shaft, using the circlip remover **(A)**.



Fig. 17-1-12-3 **(A)** Circlip Remover

7. Loosen securing bolts of front axle shaft drive flange and take off drive flange.



Fig. 17-1-13

8. Straighten bent part of lock washer and remove wheel bearing lock nut with special tool **(B)**.

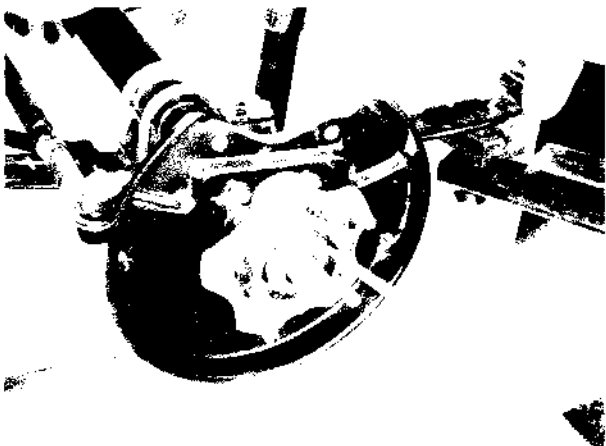


Fig. 17-1-14

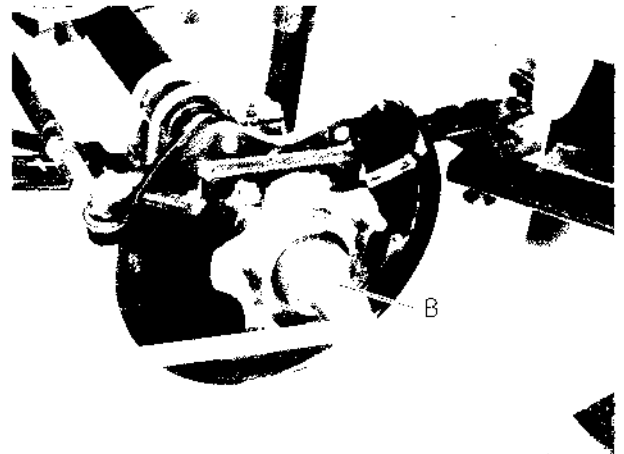


Fig. 17-1-15 Special tool **(B)**  
(Front Wheel Bearing Nut Socket Wrench 09941-58010)

9. After loosening front wheel bearing nut with the same special tool **(B)** as mentioned in the foregoing step 8, take nut and washer off the front wheel spindle.

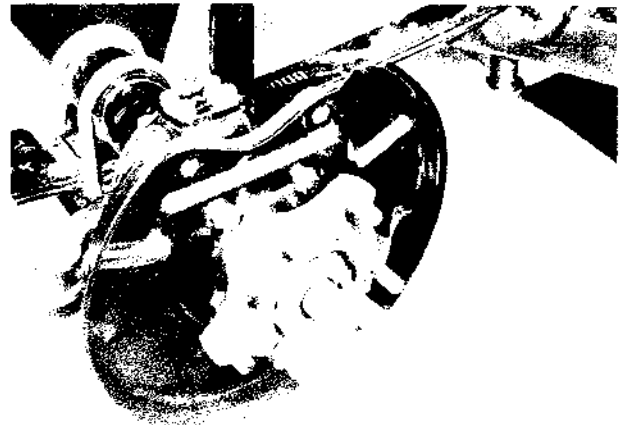


Fig. 17-1-16

10. Pull front wheel hub off the front wheel spindle.

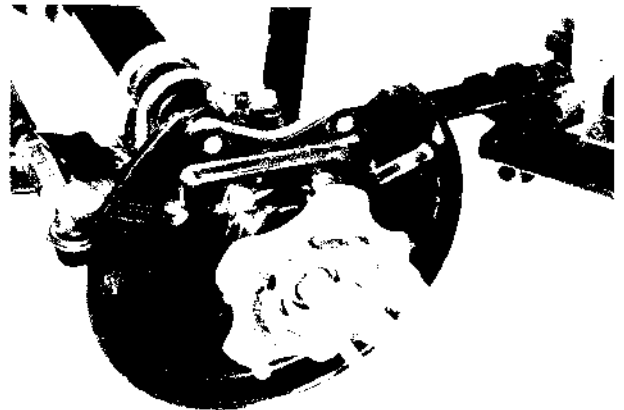


Fig. 17-1-17

11. Remove oil seal and outer race of inner bearing or outer bearing from wheel hub.

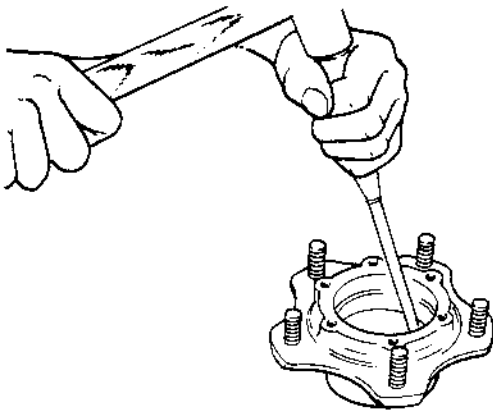


Fig. 17-1-18

### Steering Knuckle

1. Remove front wheel hub, referring to steps 1 to 10 of foregoing front wheel hub and bearing removal.
2. Loosen bolts securing kingpins (upper & lower). At this point, king pins mustn't be removed.

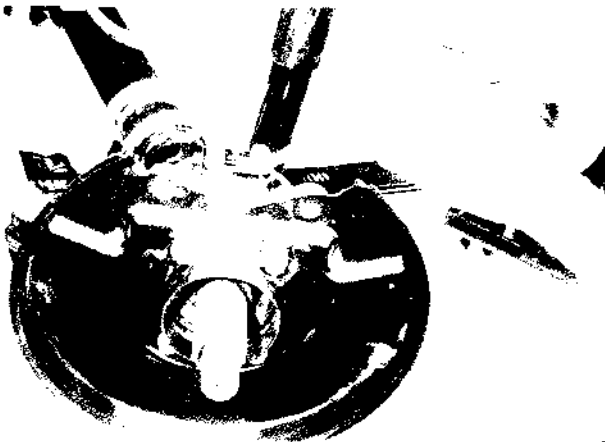


Fig. 17-1-19

3. Remove disc dust cover, caliper holder and wheel spindle.



Fig. 17-1-20

4. Remove tie rod end castle nut and disconnect tie rod end from steering knuckle with special tool (A).

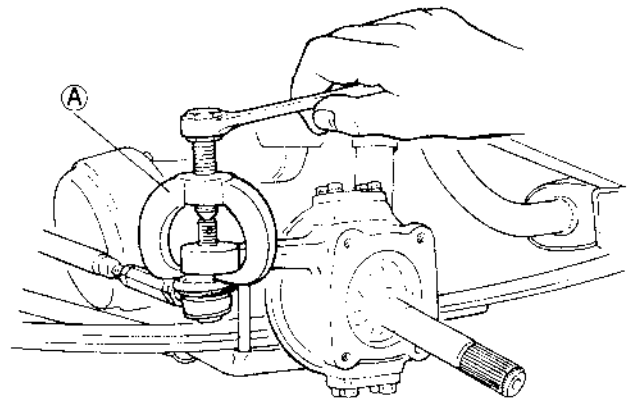


Fig. 17-1-21 Special tool (A) (Tie Rod End Remover 09913-65210)

5. Remove joint seal bolts. Then remove oil seal cover, pad, oil seal and retainer from knuckle.



Fig. 17-1-22



6. Remove lower and upper kingpins.

**NOTICE:**

- Upper and lower kingpins, when removed, must be marked off one from the other.
- Also make sure to check the number of kingpin shims that were fitted on each side.



*Fig. 17-1-23*

7. Pull off steering knuckle.

**NOTICE:**

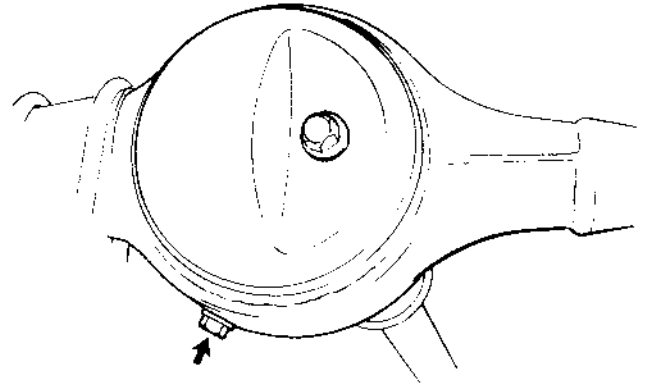
- When steering knuckle is pulled, lower kingpin bearing sometimes falls off. So remove bearing while pulling off the knuckle gradually.
- Upper and lower kingpin bearings must be also marked off one from the other.



*Fig. 17-1-24*

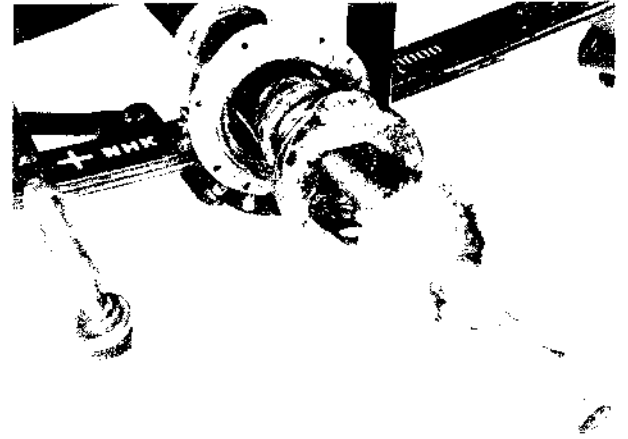
**Front Axle Shaft Joint**

1. To remove axle shaft joint, carry out steps 1 through 7 of steering knuckle removal (p. 17-8 and 17-9) and then follow steps 2 and 3 given below.
2. Drain oil from differential housing by loosening drain plug.



*Fig. 17-1-25*

3. Pull axle shaft joint off front axle housing.



*Fig. 17-1-26*

## INSPECTION OF COMPONENT

### Stabilizer and its Bush

Inspect stabilizer for damage or deformation. If defective, replace.

Inspect bushes for damage, wear or deterioration. If defective, replace.

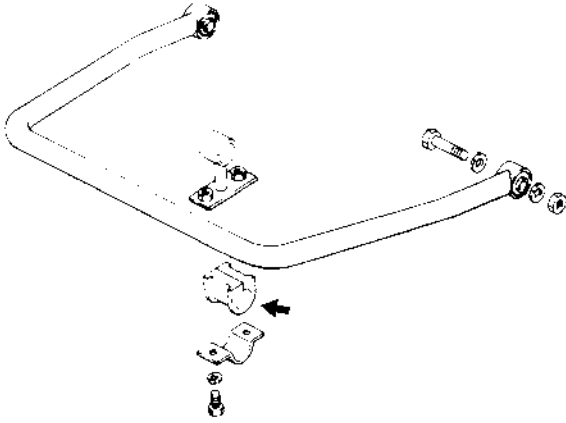


Fig. 17-1-27

### Leaf Spring Bushes

Inspect for wear and breakage. If found defective, replace.

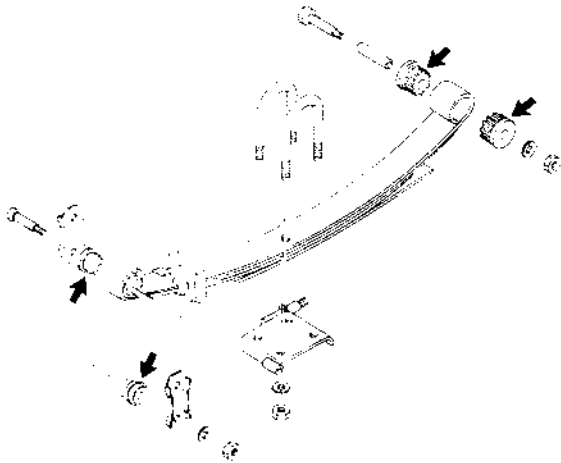


Fig. 17-1-28

### Barfield Joint

To be checked on this joint is its axial play, which shows up when a push-and-pull motion is given to live axle shaft and wheel spindle held in both hands, as shown in figure. There should be no play at all but a play of up to 1.5 mm (0.06 in.) is permissible. If play exceeds service limit, replace it.

	Standard	Service Limit
Axial play in barfield joint	0 mm (no play)	1.5 mm (0.06 in.)

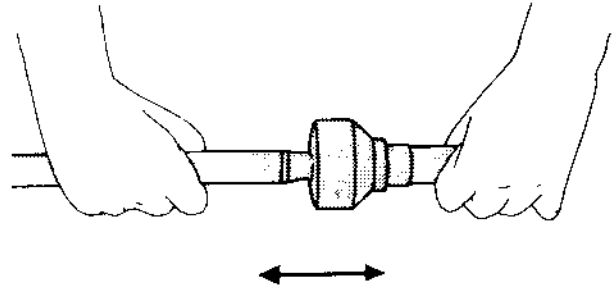


Fig. 17-1-29

### Front Wheel Bearing

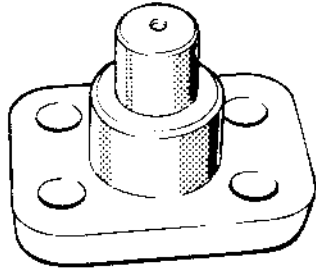
Check front wheel bearing rollers for damage. If anything is found wrong, replace bearing with a new one.



Fig. 17-1-30

### Kingpins and Bearings

Inspect each kingpin closely for dents, signs of cracking, distortion or any other damage. Replace the kingpins found in defective condition.



*Fig. 17-1-31*

Check the kingpin bearings for damage. If anything is found wrong, replace the bearing with new one.

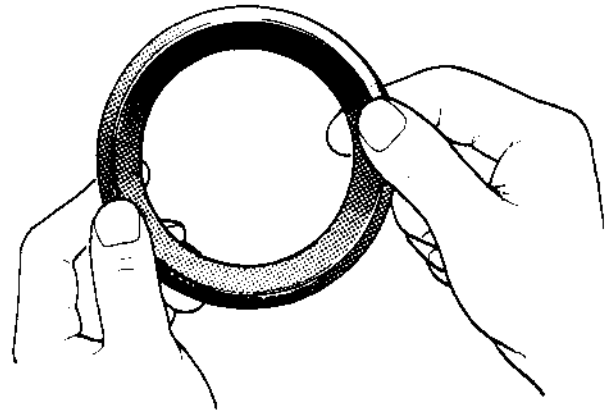


*Fig. 17-1-32*

### Steering Knuckle Oil Seal

The oil seal used at the spherical sliding joint between the knuckle and the inner case accomplishes the additional purposes of keeping out road dust and of acting as the damper for the steering handwheel. As the wear of this seal advances, its damping effect decreases and thus make the front wheel develop a tendency to "shimmy" not only that road dust begins to creep into the sliding clearance to promote the wear of the spherical sliding surfaces.

Check the oil seal for wear or damage. If defective, replace with new one.



*Fig. 17-1-33*

## INSTALLATION

Reverse removal procedure observing each precaution.

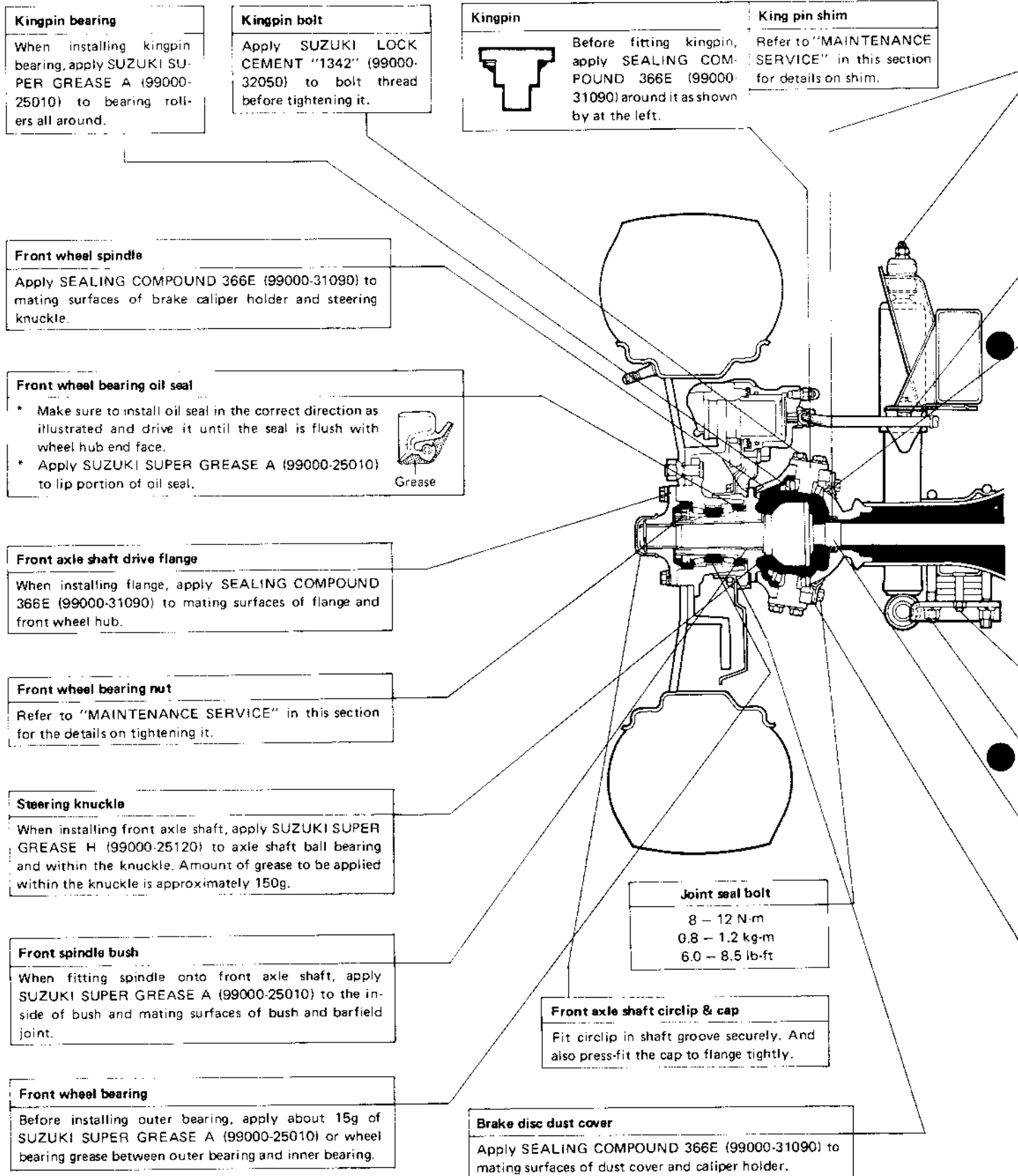


Fig. 17-1-34

**Shock absorber lock nut**

22 – 35 N·m  
 2.2 – 3.5 kg·m  
 (16.0 – 25.0 lb·ft)

**Front axle shaft oil seal**

Grease

- \* Before installing oil seal, apply SUZUKI SUPER GREASE A (99000-25010) to its lip portion.
- \* Use care for correct installing direction, referring to the illustration.

**Spring bumper bolt**

18 – 28 N·m  
 1.8 – 2.8 kg·m  
 (13.5 – 20.0 lb·ft)

**Steering knuckle oil seal**

Grease

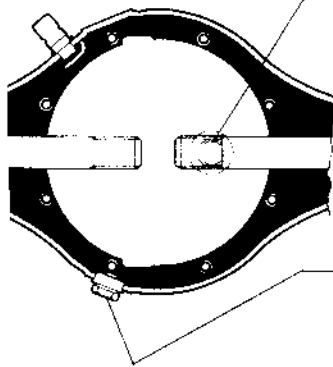
- Before installing oil seal, apply SUZUKI SUPER GREASE A (99000-25010) to its lip portion.

**Oil level & filler plug**

35 – 50 N·m  
 3.5 – 5.0 kg·m  
 25.5 – 36.0 lb·ft

**Oil drain plug**

40 – 70 N·m  
 4.0 – 7.0 kg·m  
 29.0 – 50.5 lb·ft

**Leaf spring center bolt & nut**

Insert bolt and nut securely into holes of axle housing seat and spring seat.

**Front spring U bolt**

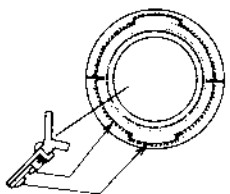
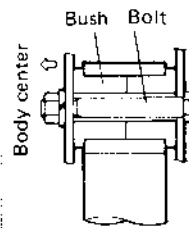
When securing U bolt, tighten its front and rear nuts evenly.

**Front axle shaft joint Ass'y**

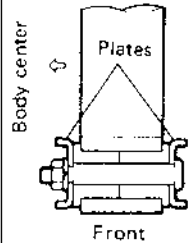
When inserting axle shaft into front axle housing, be careful not to cause any damage or distortion to axle shaft oil seal.

**Oil seal retainer**

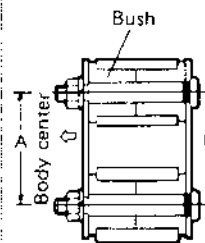
When installing retainer, apply SEALING COMPOUND 366E (99000-31090) all around it.

**Front leaf spring bush & spring bolt**

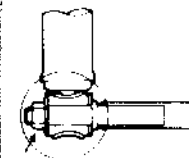
- \* Either water or household type detergent may be used to press-fit the bush onto spring. But oil of any kind is strictly prohibited.
- \* Insert both right and left bolts from the outside into the inside of body.

**Front leaf spring shackle plate**

Install plates with their backs directed to each other.

**Front leaf spring shackle pins & bush**

- \* Insert both right and left pins from outside into inside of body.
- \* Tighten nuts to specified torque in unloaded state.
- \* When pins are inserted, make sure that the difference (A – B) is within  $-0.3 \sim +0.3$  mm ( $-0.024 \sim +0.024$  in).
- \* Either water or household type detergent may be used to press-fit bush onto spring. But oil of any kind is strictly prohibited.

**Shock absorber & nut**

For correct installing direction of absorber washer, refer to the figure.

35 – 55 N·m  
 3.5 – 5.5 kg·m  
 (25.5 – 39.5 lb·ft)

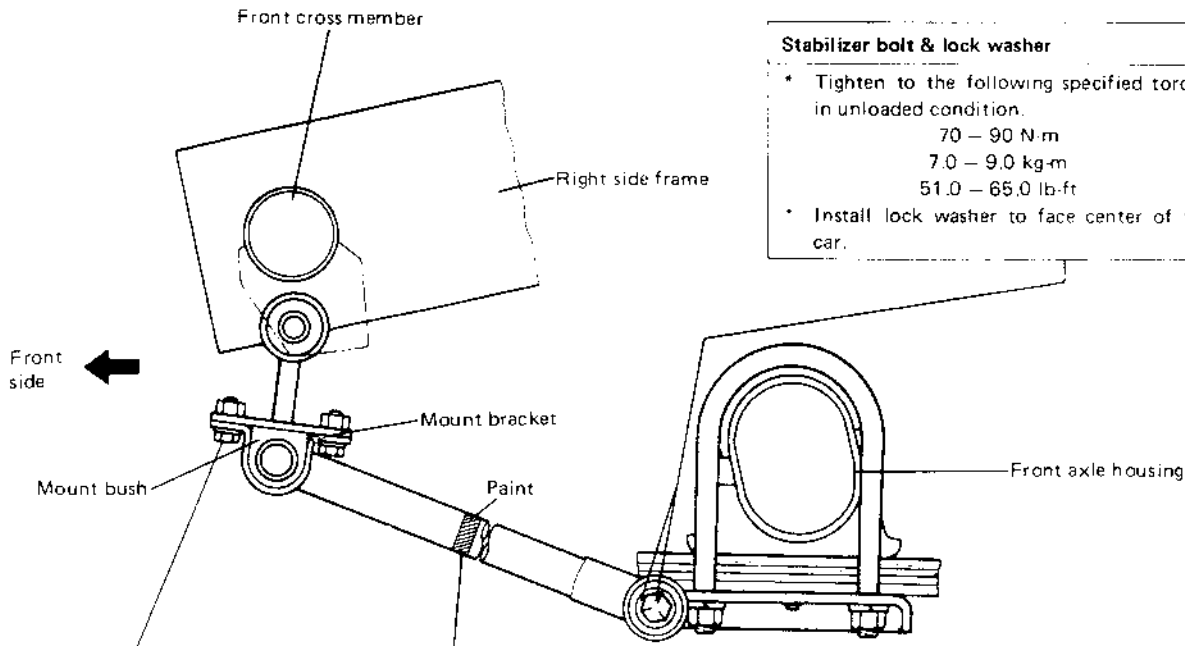
**NOTE:**

Torque specifications of other bolts and nuts are given under "RECOMMENDED TORQUE SPECIFICATIONS" of this section.

# Stabilizer

**Stabilizer bolt & lock washer**

- Tighten to the following specified torque in unloaded condition.
  - 70 – 90 N·m
  - 7.0 – 9.0 kg·m
  - 51.0 – 65.0 lb·ft
- Install lock washer to face center of the car.



**Stabilizer mount bracket bolt**

Tighten to the following specified torque in unloaded condition.

- 18 – 28 N·m
- 1.8 – 2.8 kg·m
- 13.5 – 20.0 lb·ft

**Stabilizer**

Install so that its painted side comes to the right side of car body.

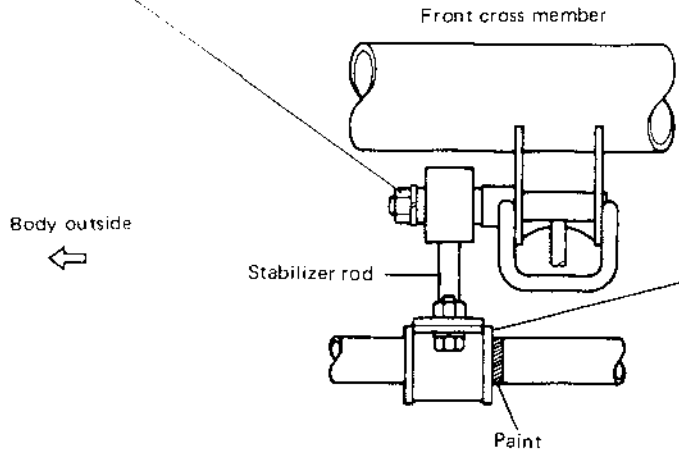
**Stabilizer nut**

Tighten to the following specified torque in unloaded condition.

- 22 – 35 N·m
- 2.2 – 3.5 kg·m
- 16.0 – 25.0 lb·ft

**Stabilizer mount bush**

Install stabilizer mount bushes (right & left) by aligning them with painted positions on stabilizer respectively.



Front side view

Fig. 17-1-35

## 17-2. REAR SUSPENSION

### GENERAL DESCRIPTION

The rear suspension consists of leaf springs, axle housing, axle shafts and shock absorbers as shown below. The leaf springs are attached to the chassis frame through rubber bushes located at their both ends as shown. The axle housing is installed on the right and left leaf springs by means of spring seats and U bolts. The two shock absorbers (right & left) are installed with their lower ends attached to the spring seats and the upper ends to the chassis frame, all through rubber bushes.

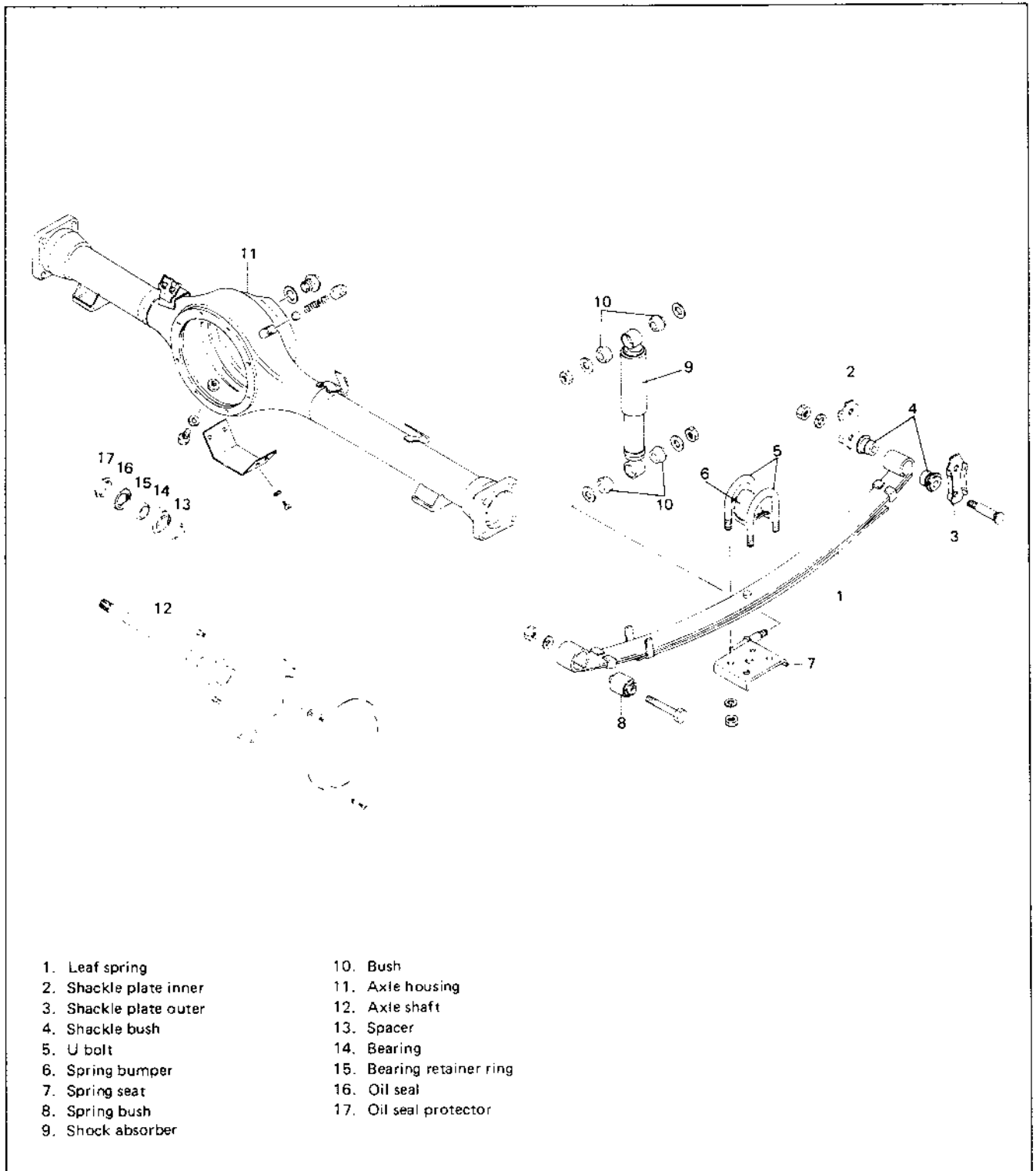


Fig. 17-2-1

## REMOVAL

### Shock Absorber

The shock absorber is non-adjustable, non-refillable, and cannot be disassembled. The only service the shock absorber requires is replacement when it has lost its resistance, is damaged, or leaking oil or gas.

- 1) Hoist car.
- 2) Loosen lower and upper nuts, and remove shock absorber.

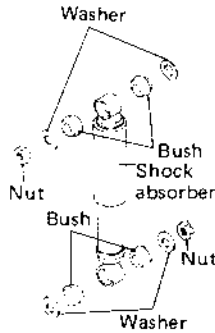


Fig. 17-2-2

### Leaf Spring

- 1) Raise car. In this operation, garage jack or hoist must not be positioned against rear suspension related parts. When garage jack is used, place safety stands under chassis to support raised body.

#### NOTICE:

Don't let rear axle housing hang on brake hose or pipe. If it occurs, hose or pipe may be damaged. To prevent it, always hold rear axle housing of raised car with safety stands.

- 2) Remove rear wheel.
- 3) Remove U bolt nuts.
- 4) Remove shackle nuts and leaf spring nut.
- 5) Pull out leaf spring bolt and remove leaf spring from shackle pin.

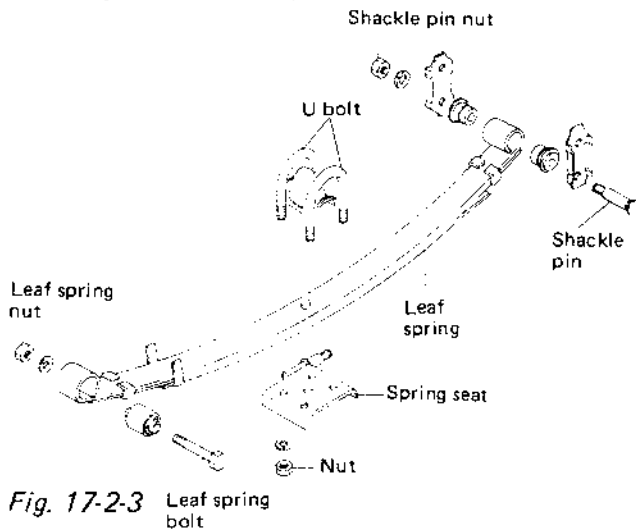
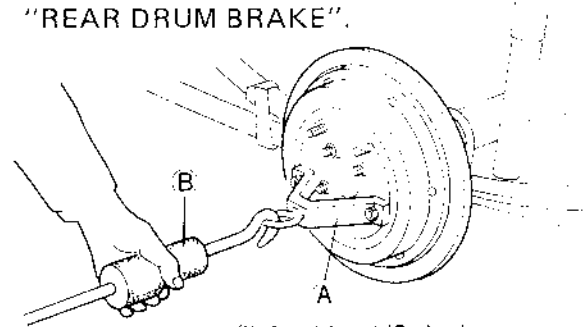


Fig. 17-2-3 Leaf spring bolt

### Rear Axle Shaft

- 1) Remove rear brake drum. Refer to item 19-3 "REAR DRUM BRAKE".



- A Special tool (Brake drum remover 09943-35511)  
 B Special tool (Sliding hammer 09942-15510)

Fig. 17-2-4

- 2) Drain oil from axle housing loosening drain plug.

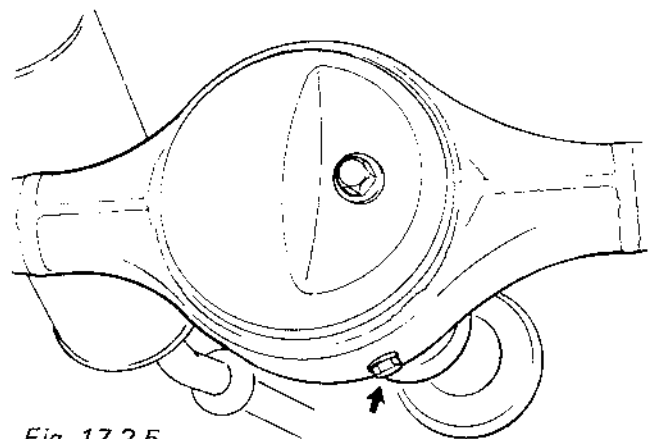


Fig. 17-2-5

- 3) Disconnect brake pipe from wheel cylinder. Have a small plug ready for use when disconnecting pipe. As pipe comes off the wheel cylinder, plug the pipe to prevent brake fluid from leaking out. And remove 4 brake backing plate securing bolts.

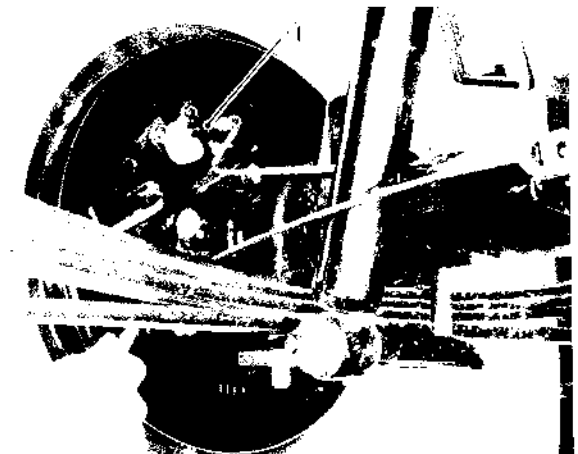


Fig. 17-2-6 1. Plug



4) Using special tools indicated below, draw out each live axle shaft with brake backing plate.

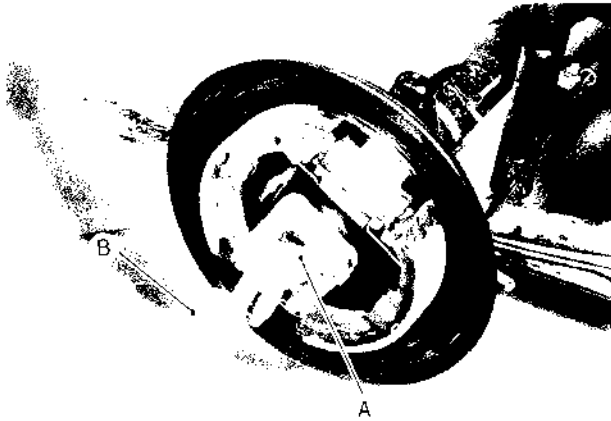


Fig. 17-2-7 Ⓐ Special Tool (Rear Axle Remover 09922-66010)  
 Ⓑ Special Tool (Sliding Hammer 09942-15510)

Rear axle shaft that was drawn out.



Fig. 17-2-8

5) In order to remove the retainer ring from the shaft, grind with a grinder two parts of the bearing retainer ring as illustrated till it becomes thin.

**CAUTION:**  
 Be careful not to go so far as to grind the shaft.

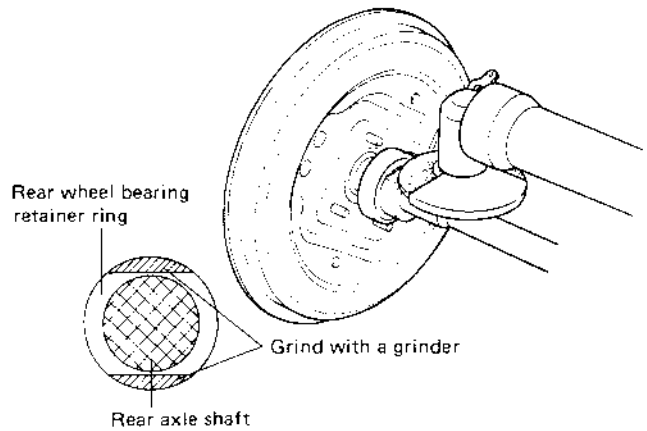


Fig. 17-2-9

Break with a chisel the thin ground retainer ring, and it can be removed.

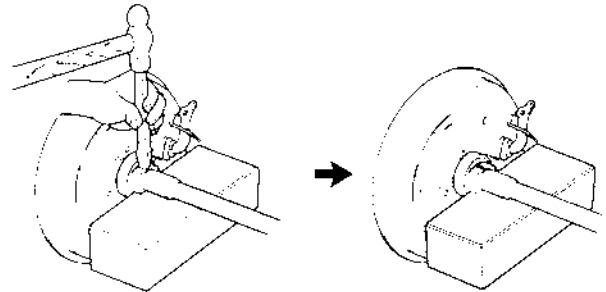


Fig. 17-2-10

6) Using special tools (C and D), remove bearing from shaft and then remove brake back plate.

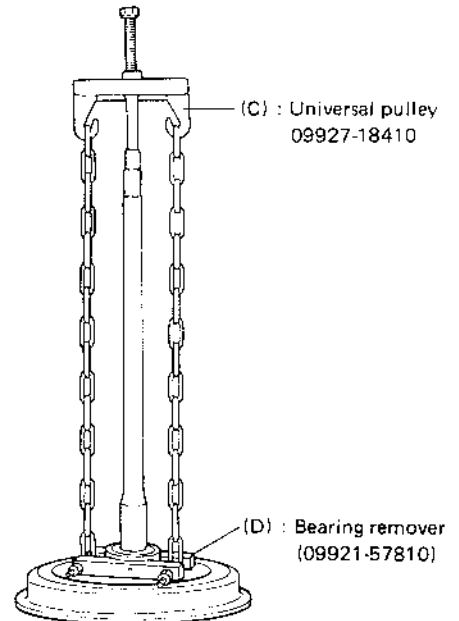


Fig. 17-2-11


# INSTALLATION

Reverse removal procedure observing each precaution.

**Rear shaft oil seal**

- Install oil seal so that the side with spring "A" faces differential side. Also, before its installation, be sure to apply SUZUKI SUPER GREASE A (99000-25010) to its lip as shown below.

Wheel side



Differential side

- Press-fit oil seal until it contacts oil seal protector.

**Brake backing plate**

When fitting brake backing plate onto the hub, apply SEALING COMPOUND 366E (99000-31090) to mating surfaces of both parts. This is to make brake drum watertight.

18 – 28 N·m  
1.8 – 2.8 kg·m  
13.5 – 20.0 lb-ft

**Rear hub bolt & nut**

When mounting hub bolts into rear axle shaft, make sure to fit the head securely in the stepped part of axle shaft.

50 – 80 N·m  
5.0 – 8.0 kg·m  
(36.5 – 57.5 lb-ft)

**Wheel nut**

50 – 80 N·m  
5.0 – 8.0 kg·m  
(36.5 – 57.5 lb-ft)

**Rear brake drum**

When installing drum, be careful not to let any foreign matter enter where drum and rear axle shaft contact.

**Rear wheel bearing spacer**

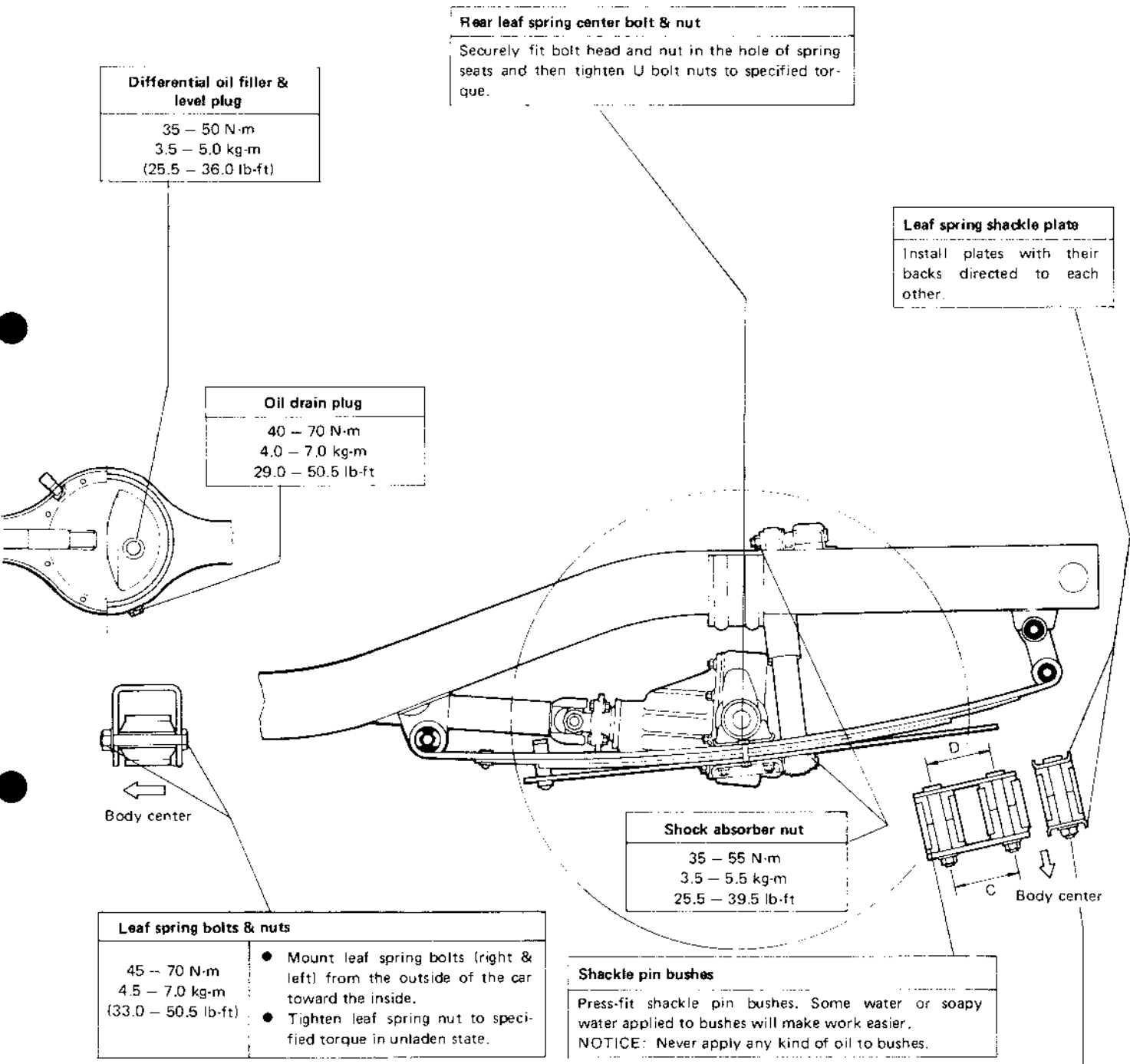
Install wheel bearing spacer with the tapered side of its inner diameter directed toward outside, or brake drum side.

**Leaf spring U bolts & nuts**

60 – 80 N·m  
6.0 – 8.0 kg·m  
(43.5 – 57.5 lb-ft)

Tighten 4 U bolt nuts uniformly so that measurement "B" is the same among the 4.

Fig. 17-2-12



**Differential oil filler & level plug**

35 – 50 N·m  
 3.5 – 5.0 kg·m  
 (25.5 – 36.0 lb-ft)

**Oil drain plug**

40 – 70 N·m  
 4.0 – 7.0 kg·m  
 29.0 – 50.5 lb-ft

**Rear leaf spring center bolt & nut**

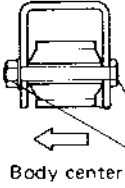
Securely fit bolt head and nut in the hole of spring seats and then tighten U bolt nuts to specified torque.

**Leaf spring shackle plate**

Install plates with their backs directed to each other.

**Shock absorber nut**

35 – 55 N·m  
 3.5 – 5.5 kg·m  
 25.5 – 39.5 lb-ft



**Leaf spring bolts & nuts**

45 – 70 N·m  
 4.5 – 7.0 kg·m  
 (33.0 – 50.5 lb-ft)

- Mount leaf spring bolts (right & left) from the outside of the car toward the inside.
- Tighten leaf spring nut to specified torque in unladen state.

**Shackle pin bushes**

Press-fit shackle pin bushes. Some water or soapy water applied to bushes will make work easier.  
 NOTICE: Never apply any kind of oil to bushes.

**Shackle pin & nuts**

30 – 55 N·m  
 3.0 – 5.5 kg·m  
 (22.0 – 39.5 lb-ft)

- Install shackle pins, both right and left, from the outside of the car toward the center.
- Tighten shackle pin nuts to specified torque in unladen state.
- When shackle pins are inserted, make sure that the difference (C – D) is within  $-0.3 \sim +0.3$  mm ( $-0.024 \sim +0.024$  in.).

## 17-3. MAINTENANCE SERVICES

### Shock Absorber

- 1) Inspect for deformation or damage.
- 2) Inspect bushings for wear or damage.
- 3) Inspect for evidence of oil leakage.

Replace any defective part.

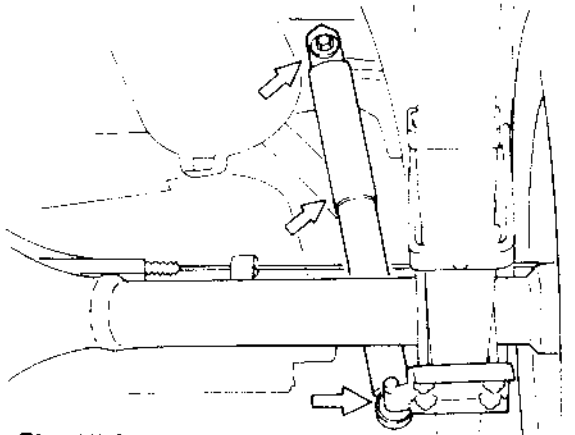


Fig. 17-3-1

#### WARNING:

When handling rear shock absorber in which high-pressure gas is sealed, make sure to observe the following precautions.

- 1) Don't disassemble it.
- 2) Don't put it into the fire.
- 3) Don't store it where it gets hot.
- 4) Before disposing it, be sure to drill a hole in it where shown by an arrow in the figure below and let gas and oil out. Lay it down sideways for this work.

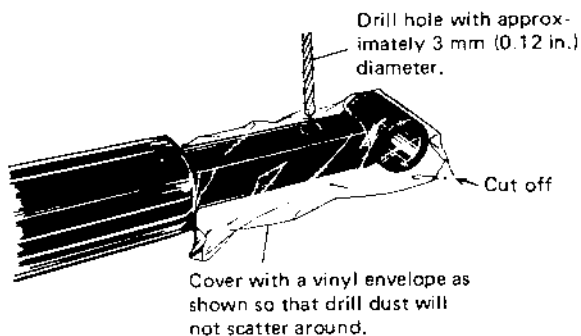


Fig. 17-3-2

### Leaf Spring and Bumper

- 1) Inspect leaf spring for crack, wear and damage.

#### NOTICE:

Special attention must be paid to that part as indicated by "A" in below figure (where each end of the shorter leaf contacts).

- 2) Inspect bumper for damage.  
If found defective, replace.

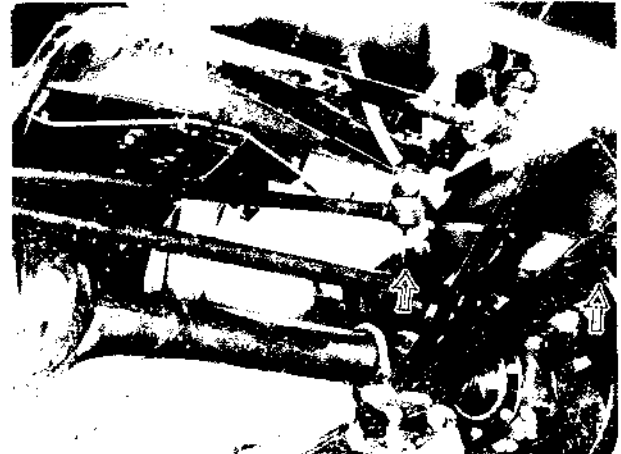


Fig. 17-3-3

### Front Wheel Bearing

[Inspection]

- (1) To check wheel bearings, jack up front end. Spin wheel and check if it is spun smoothly and is free from abnormal noise. If it isn't, replace wheel bearing.

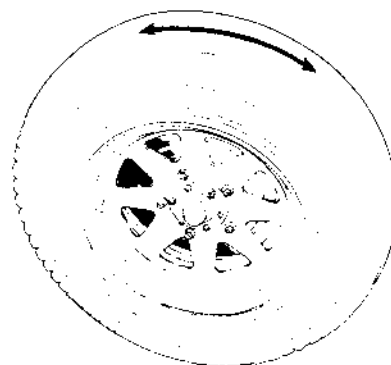


Fig. 17-3-4

- (2) Upon completion of the check in above(1), check each joint of steering system for tightness, each ball stud of the steering link as well as each kingpin for rattle. Then check bearing as described below.

- 1) Shake wheel in the direction indicated by an arrow in below figure to see if bearing rattles.

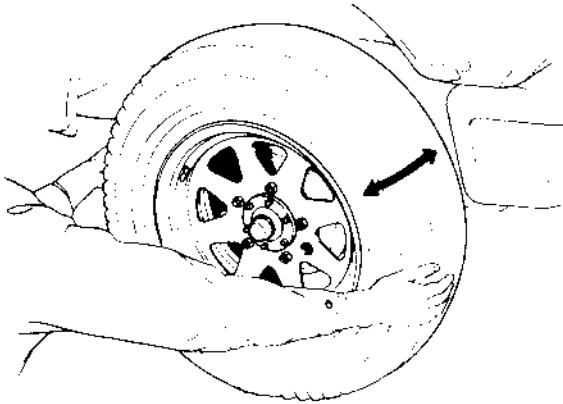


Fig. 17-3-5

- 2) Shake wheel in the direction indicated by an arrow in below figure to see if bearing rattles.

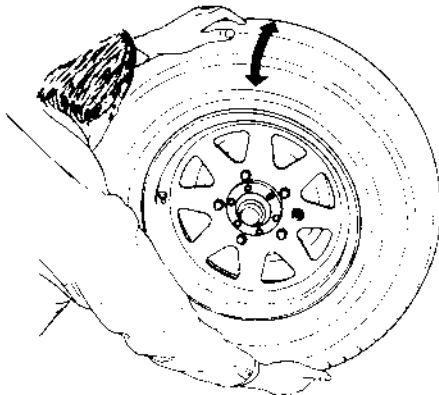


Fig. 17-3-6

- 3) If bearing rattles, check bearing preload with wheel, drive flange or free wheeling hub (if equipped) and brake caliper & holder removed as shown in below figure.

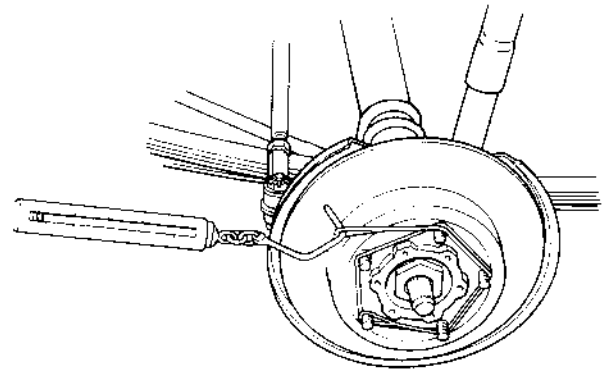


Fig. 17-3-7

Wheel bearing starting preload	1.0 – 3.0 kg (2.2 – 6.6 lb)
--------------------------------	--------------------------------

If preload is not within the above specification, adjust bearing preload according to following "adjustment".

[Adjustment]

- (1) After removing wheel bearing lock nut and lock washer, tighten bearing nut ① to the torque of 80 N·m (8.0 kg·m, 57.5 lb-ft) while spinning hub by hand. Next, loosen the nut until the torque becomes 0 N·m (0 kg·m, 0 lb-ft) and then tighten it again to tightening torque specified below.

In this way, an appropriate bearing preload is obtained.

Wheel bearing nut ① tightening torque	10.0 – 15.0 N·m 1.0 – 1.5 kg·m (7.5 – 10.5 lb-ft)
---------------------------------------	---

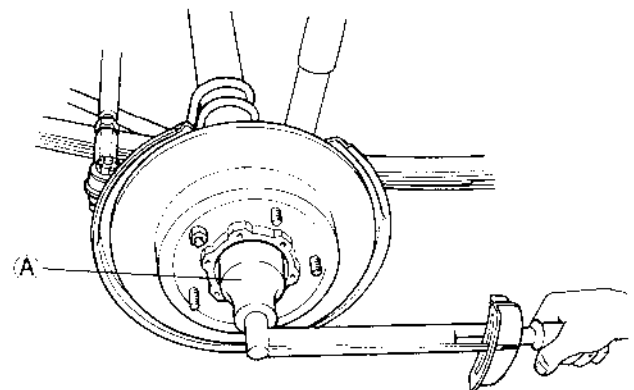


Fig. 17-3-8 Ⓐ Special tool (Front Wheel Bearing nut socket wrench 09941-58010)

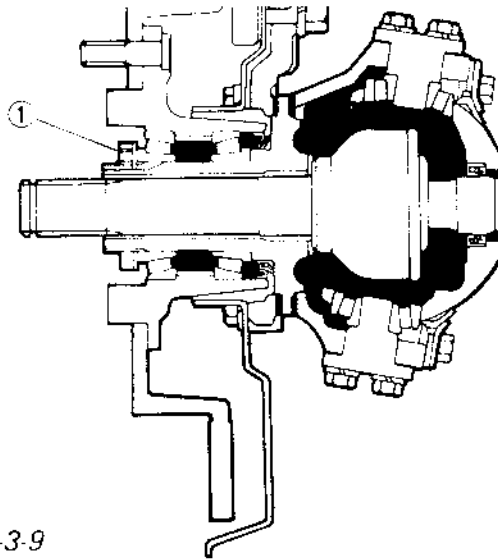


Fig. 17-3-9

- (2) Be sure to insert lock washer after adjustment and tighten lock nut ② to specified torque. Then bend a part of lock washer toward bearing nut (body side) and another part toward lock nut (outside) so that these 2 nuts are locked.

Wheel bearing lock nut ② tightening torque	60 – 90 N·m 6.0 – 9.0 kg·m (43.5 – 65.0 lb·ft)
---	--

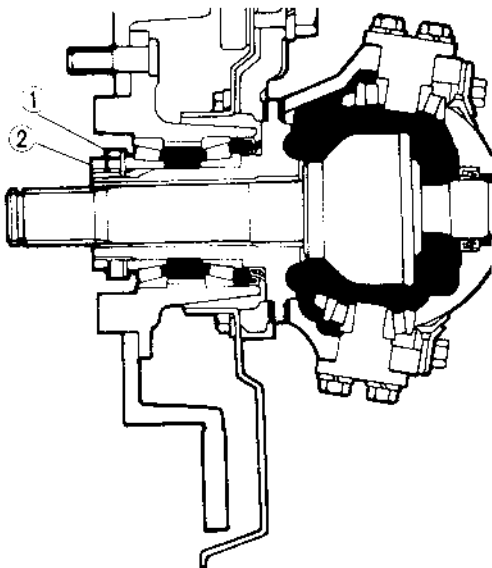


Fig. 17-3-10 ① Wheel Bearing Nut  
2 Wheel Bearing Lock Nut

- (3) Recheck that bearing starting preload is within specification.  
 (4) Upon completion of adjustment, be sure to install axle shaft drive flange or free wheeling hub (if equipped), circlip, disc brake caliper & holder and wheel.

Refer to "INSTALLATION" in this section.

### King Pin

[Inspection and adjustment]

Where tapered roller bearings holding 2 kingpins at each front wheel are in good and properly preloaded (tightened) condition, there will be no appreciable rattle of wheel. To check kingpins and their tapered roller bearings, jack up the front end and shake wheel to feel any rattle, as shown in figure. If rattle is felt, eliminate it by properly decreasing the shim thickness. The shim is located between flanged part of kingpin and knuckle.

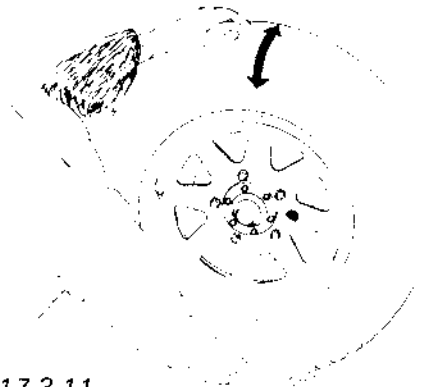


Fig. 17-3-11

The above-mentioned method of making a shim adjustment demands a high degree of skill on the part of the serviceman. The alternative method is to adjust shim thickness by referring to the torque resistance which knuckle arm offers when pulled in the condition shown in figure. For this method, the reference torque value is established as indicated below, and you are to increase or decrease shim thickness to produce this torque value.

### NOTICE:

After removing wheel and steering knuckle oil seal and disconnecting tie rod end, this checking and adjustment should be carried out.

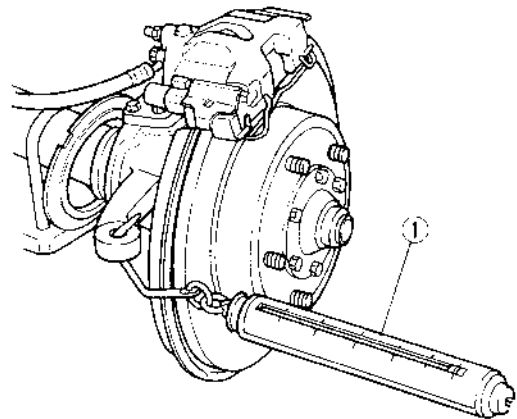


Fig. 17-3-12 ① Spring Balance

Before giving a test pull to knuckle arm with a spring balance in the alternative method, install a large amount of shims on each kingpin to lighten preload on tapered roller bearing. Keep on reading the torque, each time decreasing shim thickness a little, and continue this process until specified torque value is obtained. (This process protects kingpins because it ensure that no excessive pull will be applied to bearings at the onset.) If the process fails to produce specified torque, that is, if desired torque resistance does not occur even when shim thickness has been reduced to zero on each kingpin, it means that bearings or kingpins are excessively worn and need replacement.

**NOTICE:**

- Read spring balance indication when knuckle arm begins to turn. In other words, you are to read "starting torque."
- When checking knuckle arm starting torque, be sure to have axle hub oil seal removed and tighten king pin bolts to specified torque.

Knuckle arm starting torque (force)	1.0 – 1.8 kg (2.20 – 3.96 lb) without oil seal
Available sizes of shim for kingpins	0.1, 0.5 mm (0.004, 0.02 in.)

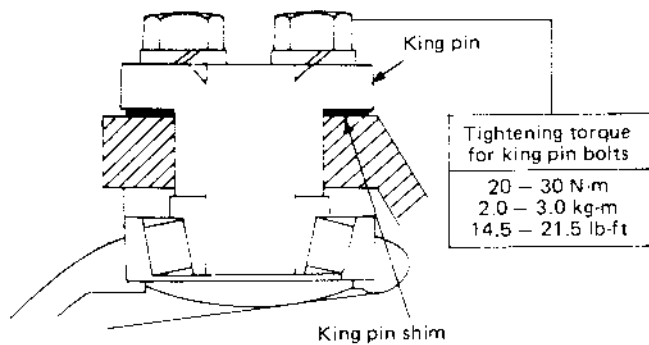


Fig. 17-3-13

Upon completion of this check and/or adjustment, be sure to connect tie rod end to steering knuckle and install oil seal retainer, oil seal, felt packing oil seal cover and wheel. Refer to "INSTALLATION" in this section.

**Steering Knuckle Oil Seal**

The oil seal used at the spherical sliding joint between knuckle and inner case accomplishes additional purposes of keeping out road dust and of acting as the damper for steering hand-wheel. As wear of this seal advances, its damping effect decreases and thus makes front wheel develop a tendency to "shimmy" not only that road dust begins to creep into sliding clearance to promote wear of spherical sliding surfaces.

The oil seal is an expendable item, and must be replaced at regular intervals.

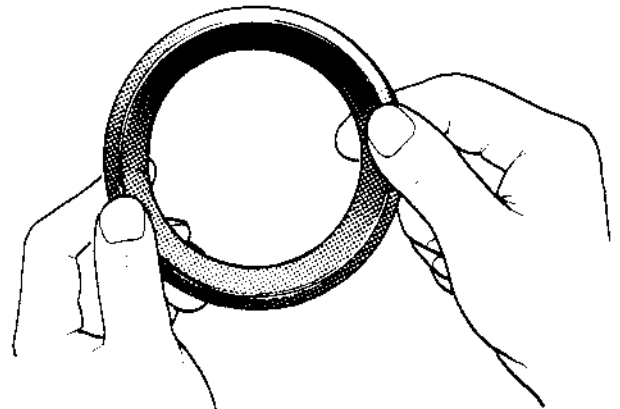


Fig. 17-3-14

[How to replace oil seal]

- 1) Remove 8 bolts securing joint seat, and displace oil seal cover and felt packing inward.

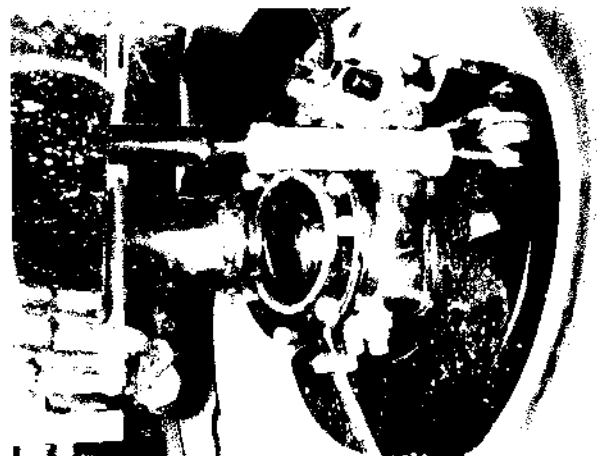


Fig. 17-3-15

- 2) Cut oil seal in place with scissors or a knife, and take it off.
- 3) Cut replacement oil seal at one place with scissors or a knife as shown in below figure.
- 4) Install the seal in oil seal retainer, bringing the cut portion to top side and locating it about 30 degrees off the matching face of oil seal retainer.

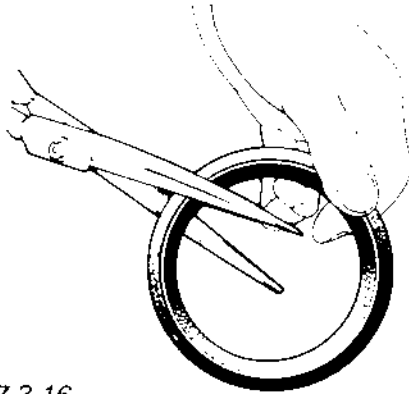


Fig. 17-3-16

- 5) Apply grease to inside of oil seal. Apply sealing compound to mating face all around: this is for preventing entry of water.

- SEALING COMPOUND "CEMEDINE" 366E (99000-31090)
- SUZUKI SUPER GREASE H (99000-25120).

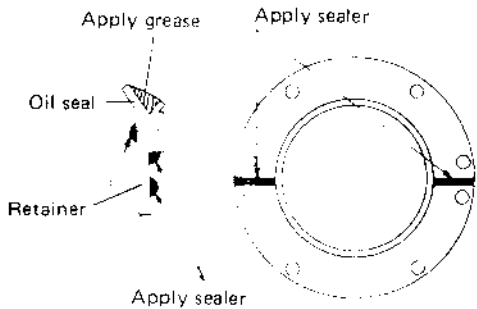


Fig. 17-3-17

- 6) Tighten joint seat securing bolts to specified torque.

### Rear Wheel Bearing

- 1) Check wheel bearings for wear. When measuring thrust play, apply a dial gauge to drum center.

Thrust play Limit	Rear	0.8 mm (0.03 in.)
-------------------	------	-------------------

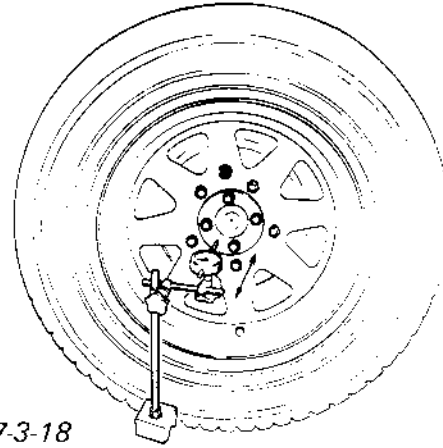


Fig. 17-3-18

When measurement exceeds limit, replace bearing.

- 2) By rotating wheel actually, check wheel bearing for noise and smooth rotation. If it is defective, replace bearing.

### Bolts and Nuts

Check following bolts and nuts for tightness and retighten them to specified torque as necessary.

Fastening parts	Tightening torque
① Shackle pin nut	Refer to "RECOMMENDED TORQUE SPECIFICATIONS" in this section.
② Leaf spring nut	
③ Leaf spring U bolt nut	
④ Wheel nut	
⑤ Front axle shaft drive flange bolt	
⑥ Kingpin upper & lower bolt	
⑦ Rear hub nut	



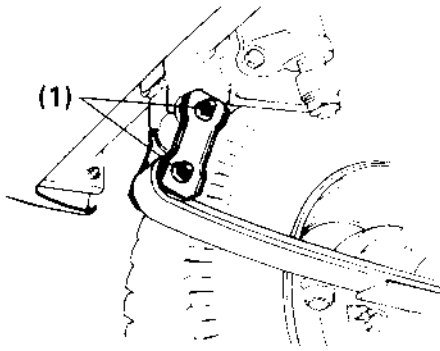


Fig. 17-3-19

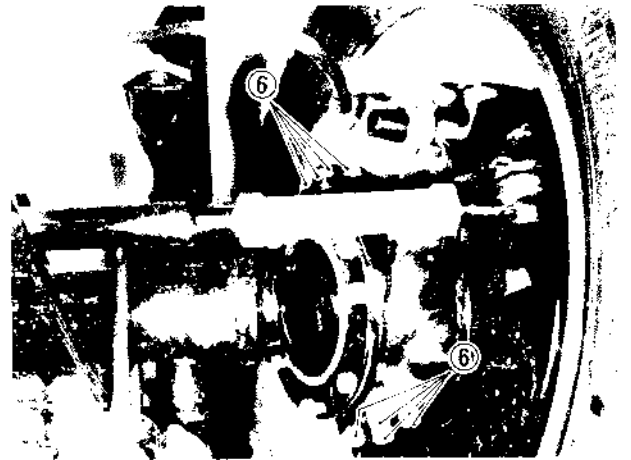


Fig. 17-3-23

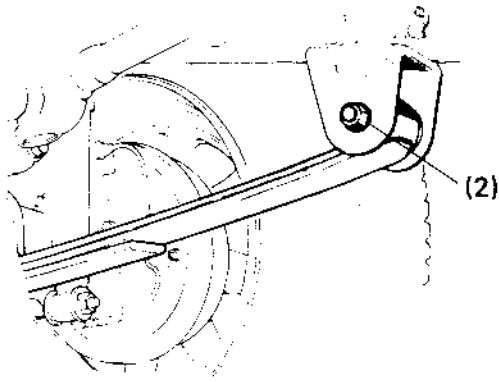


Fig. 17-3-20

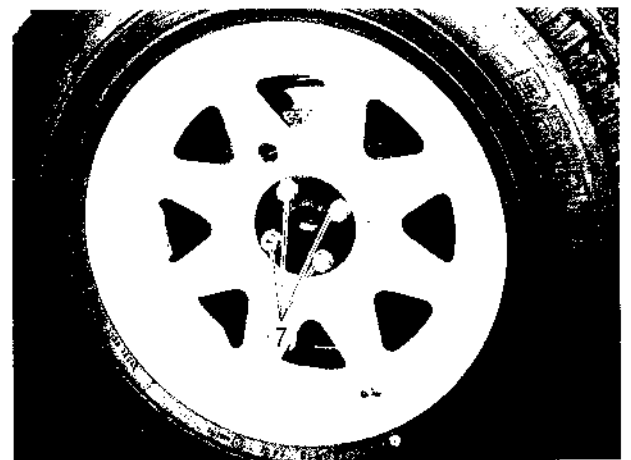


Fig. 17-3-24

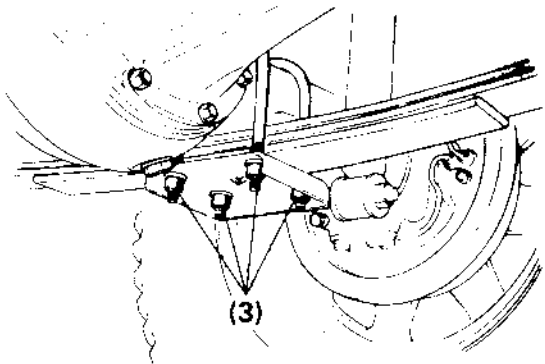


Fig. 17-3-21

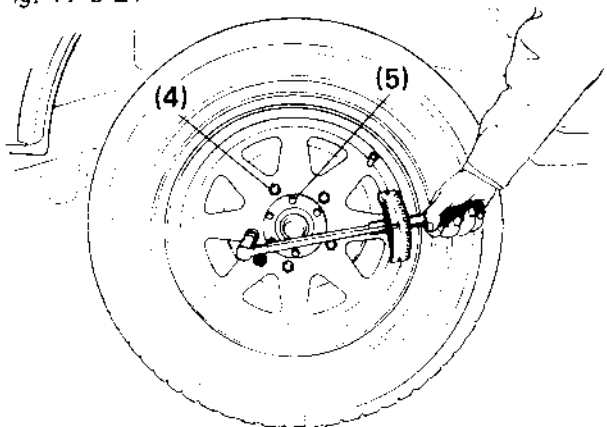


Fig. 17-3-22

## 17-4. RECOMMENDED TORQUE SPECIFICATIONS

Fastening parts	Tightening torque		
	N·m	kg·m	lb·ft
Schackle pin nut	30 – 55	3.0 – 5.5	22.0 – 39.5
Leaf spring nut	45 – 70	4.5 – 7.0	33.0 – 50.5
Leaf spring U bolt nut	60 – 80	6.0 – 8.0	43.5 – 57.5
Wheel nut	50 – 80	5.0 – 8.0	36.5 – 57.5
Front axle shaft drive flange bolt	20 – 30	2.0 – 3.0	14.5 – 21.5
Kingpin upper & lower bolts	20 – 30	2.0 – 3.0	14.5 – 21.5
Joint seal bolt	8 – 12	0.8 – 1.2	6.0 – 8.5
Front & rear shock absorber lower nut	35 – 55	3.5 – 5.5	22.5 – 39.5
Front shock absorber upper lock nut	22 – 35	2.2 – 3.5	16.0 – 25.0
Front leaf spring bumper bolt	18 – 28	1.8 – 2.8	13.5 – 20.0
Stabilizer bolt	70 – 90	7.0 – 9.0	51.0 – 65.0
Stabilizer nut	22 – 35	2.2 – 3.5	16.0 – 25.0
Stabilizer mount bracket bolt	18 – 28	1.8 – 2.8	13.5 – 20.0
Front wheel bearing nut	10 – 15	1.0 – 1.5	7.5 – 10.5
Front wheel bearing lock nut	60 – 90	6.0 – 9.0	43.5 – 65.0
Differential oil drain plug	40 – 70	4.0 – 7.0	29.0 – 50.5
Differential oil filler & level plug	35 – 50	3.5 – 5.0	25.5 – 36.0
Rear hub nut	50 – 80	5.0 – 8.0	36.5 – 57.5

## 17-5. FRONT FREE WHEELING HUB (OPTIONAL)

### General Description

This section describes operation, installation and maintenance of free wheeling hub. Be sure to refer to this section carefully for proper service.

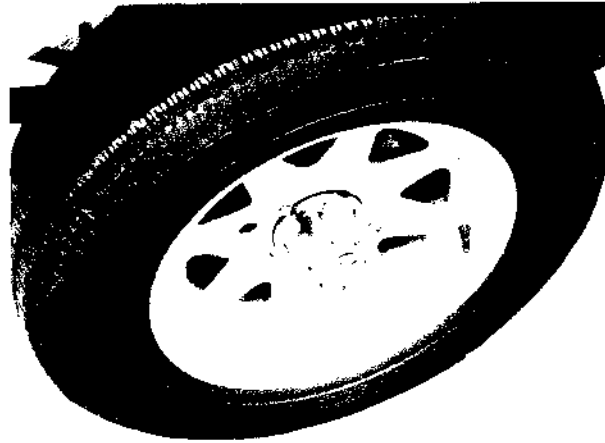


Fig. 17-5-1

### Operation

A free wheeling hub should be fitted onto each of the right and left front wheel hubs. The free wheeling hub has a knob and two embossed marks, "FREE" and "LOCK". When the knob is set to the "FREE" position, the axle shaft and wheel are disconnected and the revolution of the front wheels becomes free. When it is set to the "LOCK" position, the axle shaft and wheel are connected.

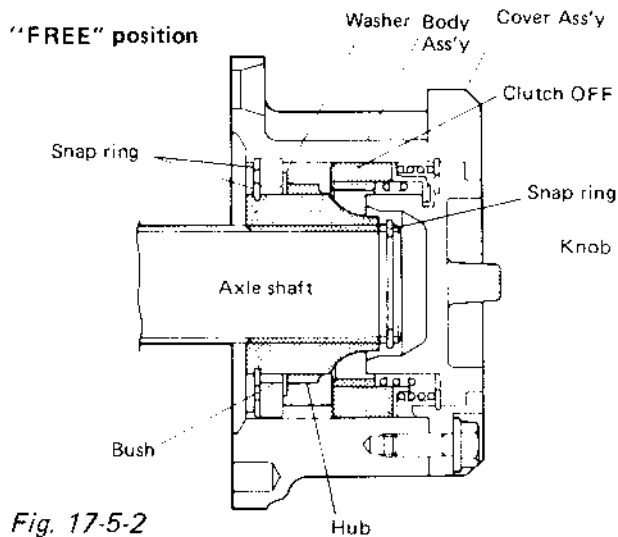


Fig. 17-5-2

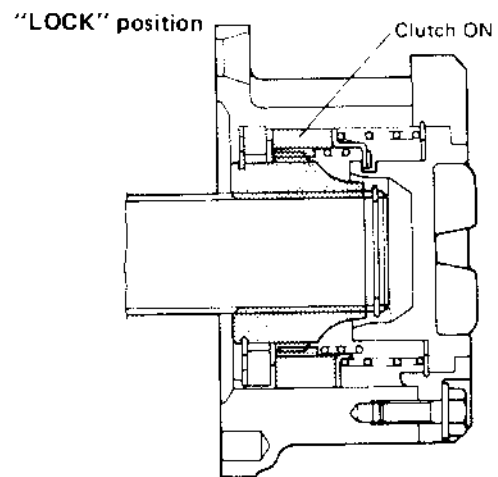


Fig. 17-5-3

For their usage, refer to Owner's Manual supplied with the car.

### CAUTION:

Both of the right and left wheeling hub knobs must be set to the same position (either FREE or LOCK). Don't set one to "FREE" and the other to "LOCK" positions.

### Installation Instruction

After removing front axle shaft drive flange, install parts (shown in below figure) in accordance with the following procedure.

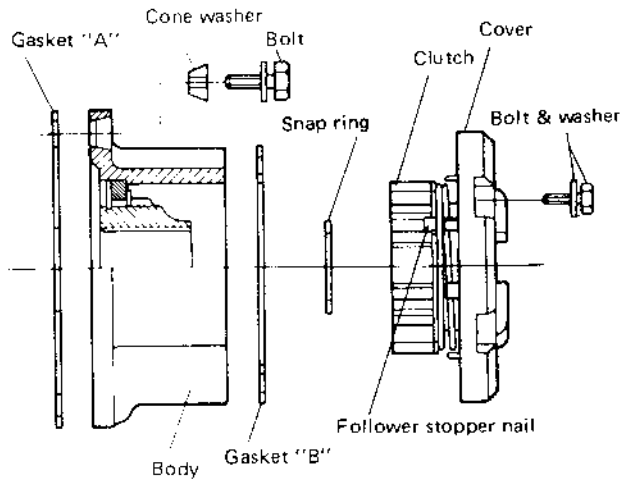


Fig. 17-5-4

- 1) After aligning " √ " mark on the knob of free wheeling hub cover with "FREE" position, separate free wheeling cover ass'y from body ass'y.
- 2) To facilitate installation, apply sealing compound 366E (99000-31090) thin.



Fig. 17-5-5

- 3) Install gasket "A" and free wheeling hub body ass'y on front wheel hub.

Tightening torque	N·m	kg·m	lb·ft
	20 - 30	2.0 - 3.0	14.5 - 21.5

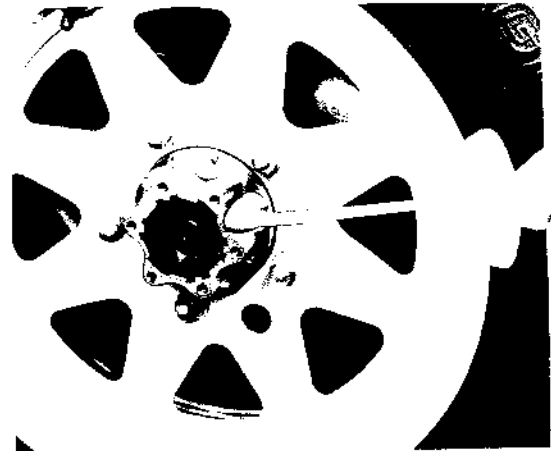


Fig. 17-5-6

- 4) Put bolt ① into front axle shaft and pull out the shaft and fit snap ring in the groove of axle shaft.  
Remove bolt ① from axle shaft.

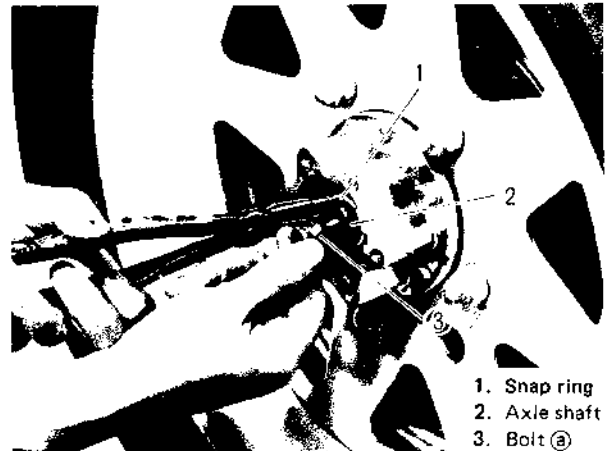


Fig. 17-5-7

- 5) Install cover ass'y to body ass'y so that follower stopper nail is fitted into groove of body ass'y.

#### NOTICE:

Before installing cover ass'y, make sure of following points.

- " √ " mark on knob is at "FREE" position.
- Clutch is lifted to the cover side, if not (shown in below figure) it may cause malfunction.
- Gasket is set justly.

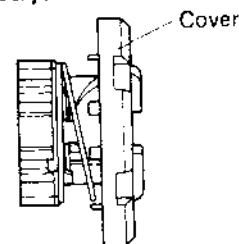


Fig. 17-5-8

There are two follower stopper nails and two grooves which can be fitted freely.

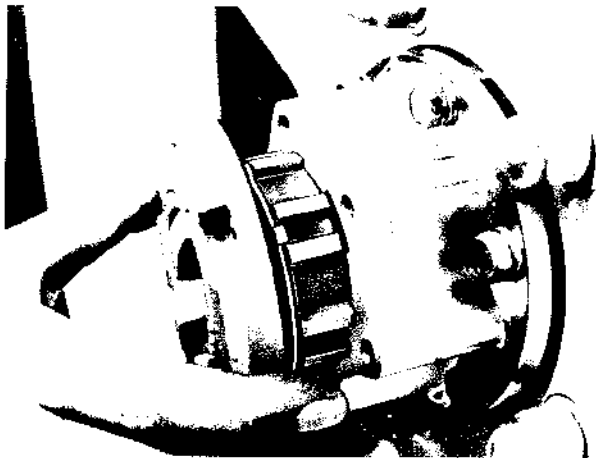


Fig. 17-5-9

6) Fix cover ass'y to body ass'y with cover bolts.

Tightening torque

Cover bolts	N·m	kg·m	lb·ft
	8-12	0.8-1.2	6.0-8.5



Fig. 17-5-10

7) To check free wheeling hub operation, jack up the front end, move the knob of free wheeling hub between "FREE" and "LOCK" positions and check for smoothness. Also check if wheel operates correctly with the knob at "FREE" and "LOCK" positions and by rotating wheel by hand.

#### Maintenance Service

The car equipped with free wheeling hubs are subject to the following periodical checks.

To check free wheeling hubs operation, jack up the front end, move the knob of free wheeling hub between "FREE" and "LOCK" positions

and check for smoothness. Also check if wheel operates correctly with the knob at "FREE" and "LOCK" positions and by rotating wheel by hand.

Should the check result be unsatisfactory, remove free wheeling hub cover and grease each sliding surface with SUZUKI SUPER GREASE A (99000-25010) or multipurpose grease after cleaning each sliding part.

If faulty operation is still noted even after greasing, correct defective part or replace it with a new one.

#### CAUTION:

Hubs should not be packed with grease.

For installation, refer to "Installation Instruction" in this section.

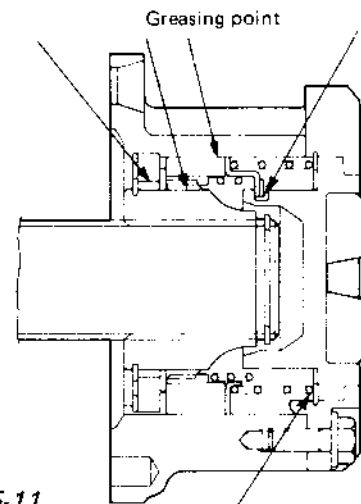


Fig. 17-5-11

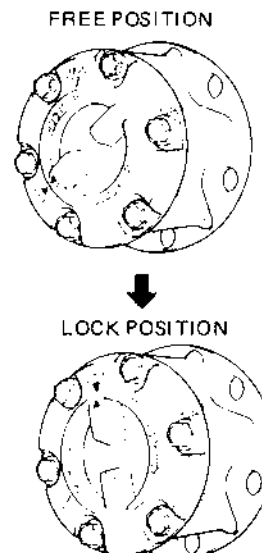


Fig. 17-5-12



## SECTION 18

# STEERING SYSTEM

### CONTENTS

18-1. GENERAL DESCRIPTION . . . . .	18-2
18-2. SPECIFICATIONS AND DATA . . . . .	18-4
18-3. STEERING GEAR BOX CONSTRUCTION AND OPERATION . . .	18-5
18-4. REMOVAL . . . . .	18-6
18-5. INSPECTION OF COMPONENTS . . . . .	18-9
18-6. CHECKING STEERING COLUMN FOR ACCIDENT DAMAGE . . .	18-11
18-7. IMPORTANT STEPS IN REINSTALLATION . . . . .	18-12
18-8. WHEEL ALIGNMENT . . . . .	18-16
18-9. MAINTENANCE SERVICES . . . . .	18-18
18-10. RECOMMENDED TORQUE SPECIFICATIONS . . . . .	18-22

#### NOTICE:

All steering system fasteners are important parts in that they could affect the performance of vital parts and systems, and/or could result in major repair expense. They must be replaced with one of the same part number or with an equivalent part if replacement becomes necessary. Do not use a replacement part of lesser quality or substitute design. Torque values must be used as specified during reassembly to assure proper retention of this part.

## 18-1. GENERAL DESCRIPTION

The rotary motion of the steering handwheel is carried to the steering shaft upper, steering shaft lower, steering gear box and pitman arm. Then as the pitman arm moves, the drag rod is caused to move linearly, actuating the tie rod to turn the wheels, right and left, through their knuckle arms. The turning force exerted by the tie rod experiences a damping action due to the presence of the oil seal at the sphere-like joint between the knuckle case and the inner case (integral with the dead axle sleeve). Another damping action is available, which will be mentioned below.

The steering system formed by the components named above is designed for easy steering, high durability and excellent steering reaction as well as reliable self-restoring action. Articulated joints in the steering lever is equipped with a damping device for ensuring the greater steering stability.

Linkage are of wear-resistant ball-and-socket type. Pitman arm is equipped with a damping device for ensuring the greater steering stability.

[Right-hand steering vehicle]

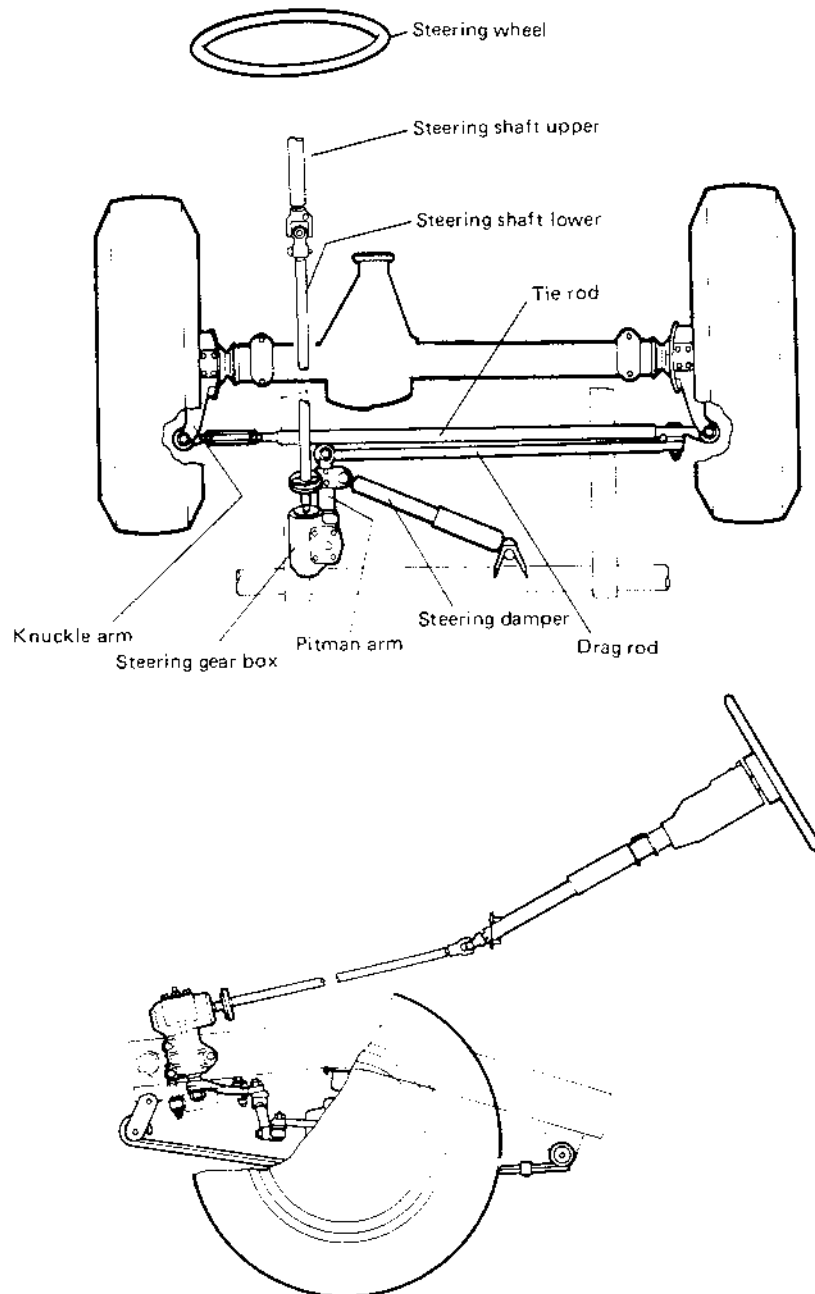


Fig. 18-1



[Left-hand steering vehicle]

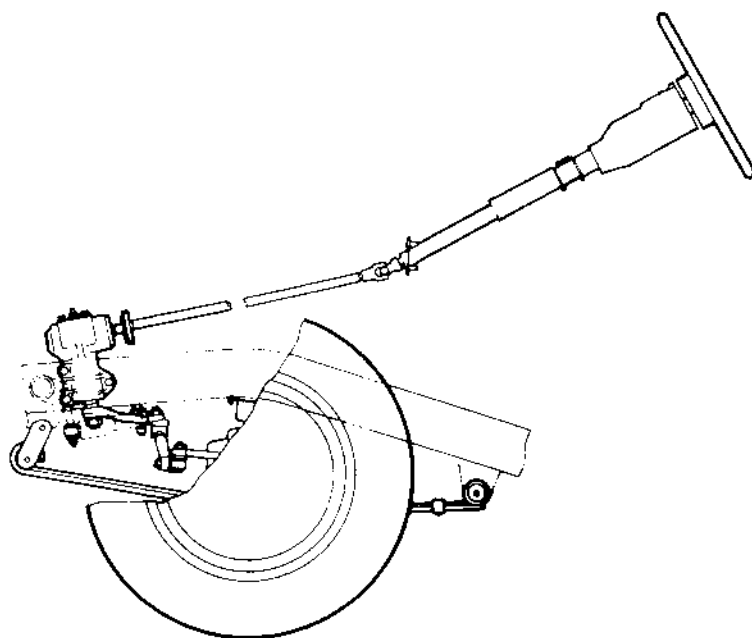
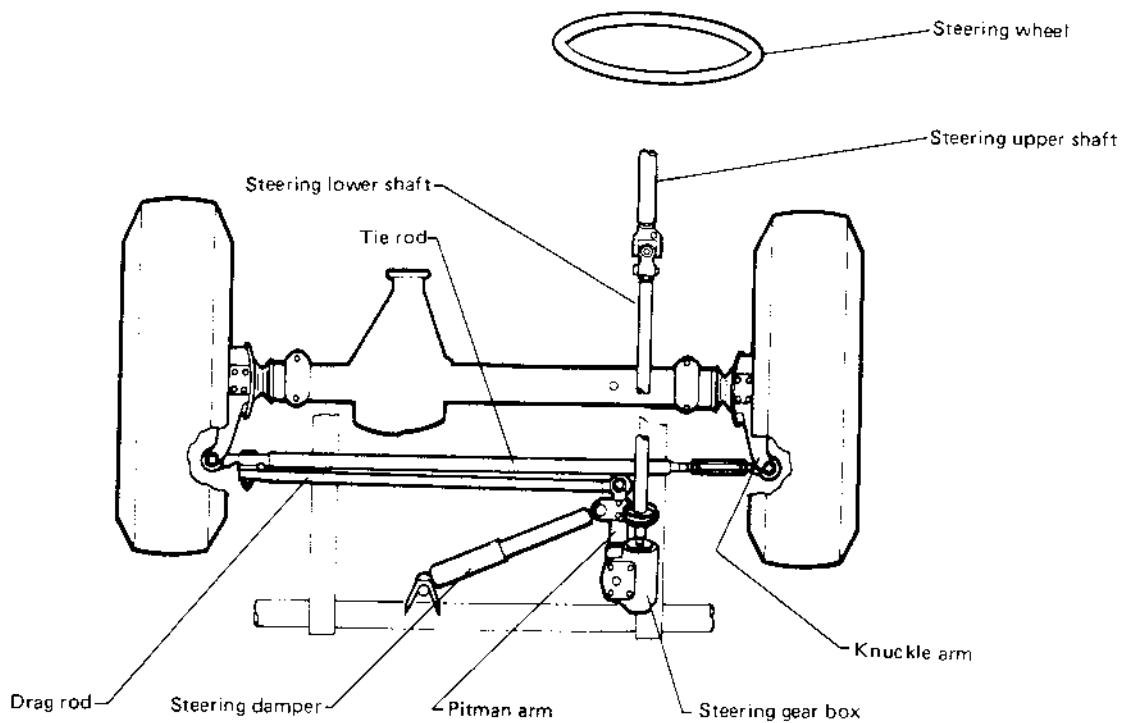


Fig. 18-1-1

## 18-2. SPECIFICATIONS AND DATA

	Steering gear box	Recirculating ball-and-nut type
	Gear ratio	15.6 – 18.1
	Steering angle, inside	$29^{\circ} \pm 3^{\circ}$
	Steering angle, outside	$26^{\circ} \pm 3^{\circ}$
	Steering wheel diameter	400 mm (15.74 in.)
	Minimum turning radius	5.1 m (16.73 ft.)
WHEEL ALIGNMENT	Toe-in	2 – 6 mm (0.079 – 0.236 in.)
	Camber	1 degree ( $1^{\circ}$ ) $\pm$ 45'
	Kingpin inclination	9 degree ( $9^{\circ}$ ) $\pm$ 2°
	Caster	3 degree 30 minutes ( $3^{\circ} 30'$ ) $\pm$ 1°
	Side slip	0 – in 3 m/km

### 18-3. STEERING GEAR BOX CONSTRUCTION AND OPERATION

The pitman arm is rigidly connected to the outer end of the shaft integral with the sector gear, which is inside the gear box and meshed with the teeth of the nut capable of sliding along the worm. Between the nut and the worm is a row of steel balls, which serves two purposes: to provide rolling contact between nut and worm and to keep the nut engaged with the worm as if the two were threadedly engaged. With the nut prevented from turning, the rotation of the worm causes the nut to move up or down the worm.

The worm is an extension of the steering shaft. As the handwheel is turned, the steel balls roll along in the groove and the nut moves up or down. The steel ball that has reached the end of the groove in the nut enters the return guide. The guide sends the ball back to the other end of the same groove. In this way, the row of balls recirculates.

By so moving, the nut turns the sector gear and hence the pitman arm. It should be noted here that it is through the steel balls that a rotary motion of the worm is converted into a linear motion of the nut, which is then converted into another rotary motion of the section gear.

The steering gear box is a precision-machined device, each part of it being machined to a closer tolerance for smooth conversion of motion, and is build sturdy for long service life. Special tools and instruments are needed in addition to specialized skill if the gear box is to be overhauled. For this reason, a gear box found to be in defective condition should be replaced with a new one; replacement is more economical and what is perhaps more important, safer.

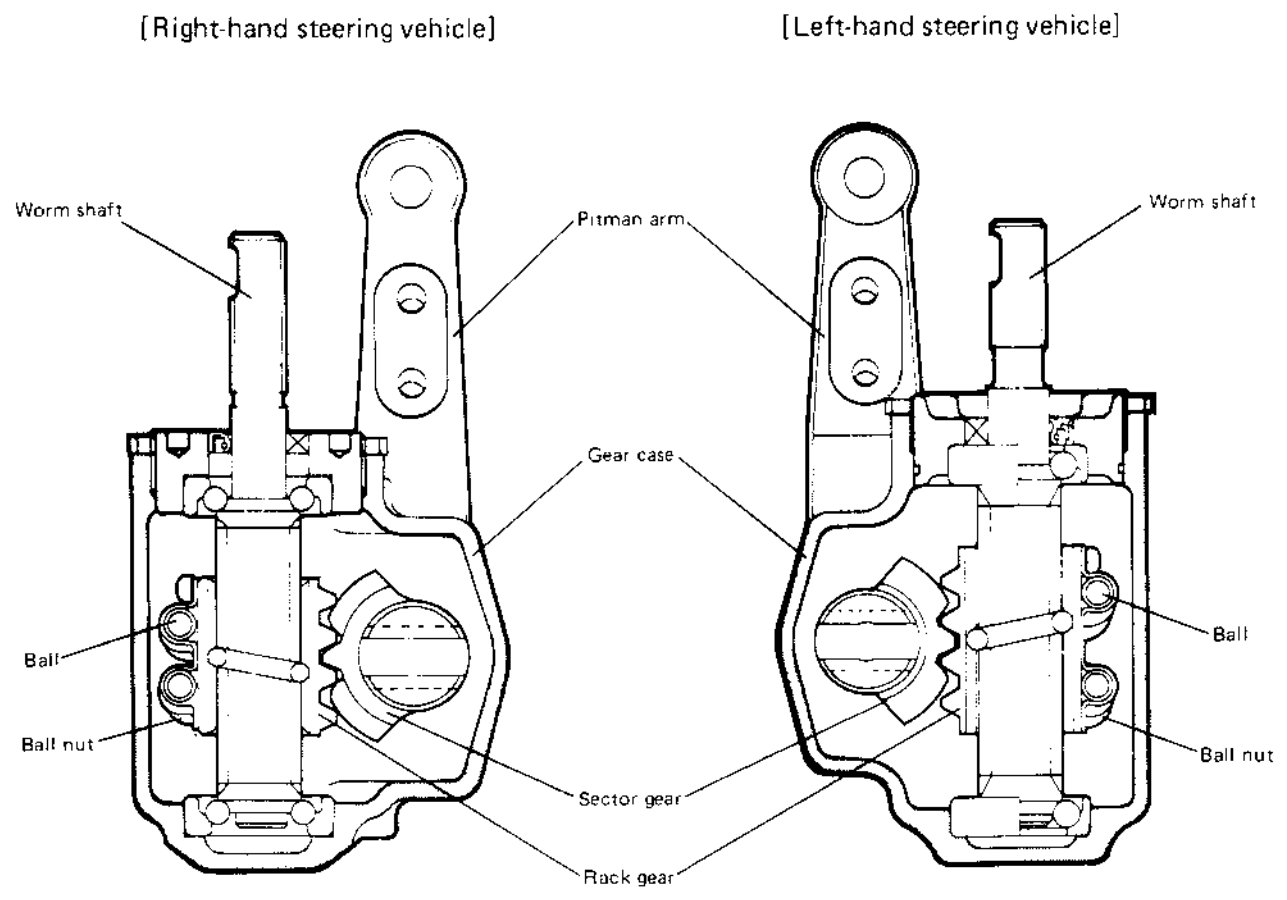


Fig. 18-2

## 18-4. REMOVAL

### NOTICE:

When removing the column assembly from the car, special care must be taken in handling it. Use of a steering wheel puller other than the steering wheel remover recommended in this manual or a sharp blow on the end of the steering shaft, leaning on the assembly, or dropping the assembly is prohibited. Any of such actions could shear the plastic shear pins which maintain column length especially.

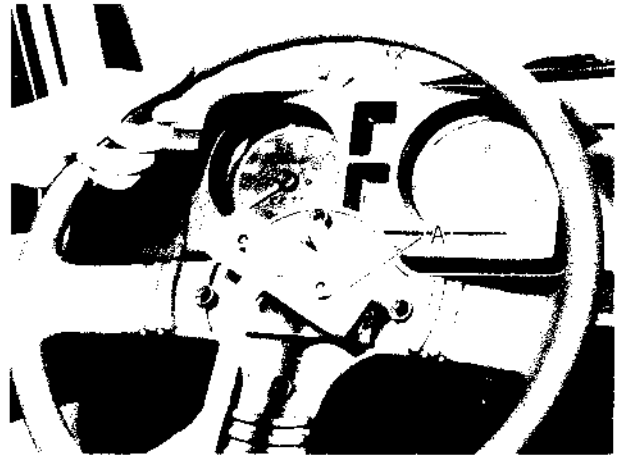


Fig. 18-4 Ⓐ Special tool (Steering wheel remover 09944-38210)

### Steering Hand Wheel

- 1) Disconnect negative battery cable.
- 2) Pull horn button to remove.

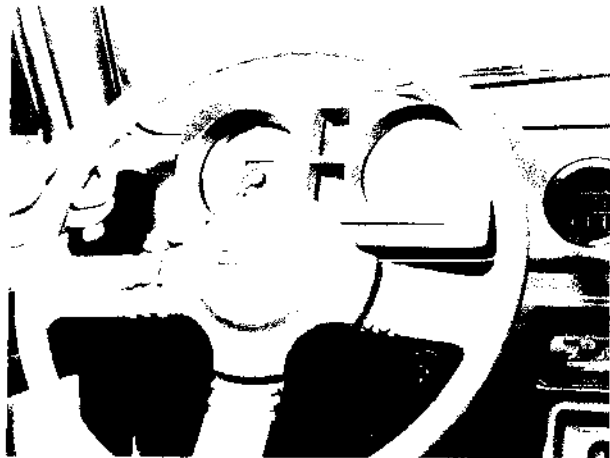


Fig. 18-3

- 3) After loosening steering shaft nut, remove steering wheel by using special tool.

### Steering Column

- 1) After removing steering handwheel according to the foregoing step, remove steering covers (lower & upper).

### NOTICE:

After removing instrument lower panel, loosen 2 screws and 4 nuts securing steering column to remove upper cover.

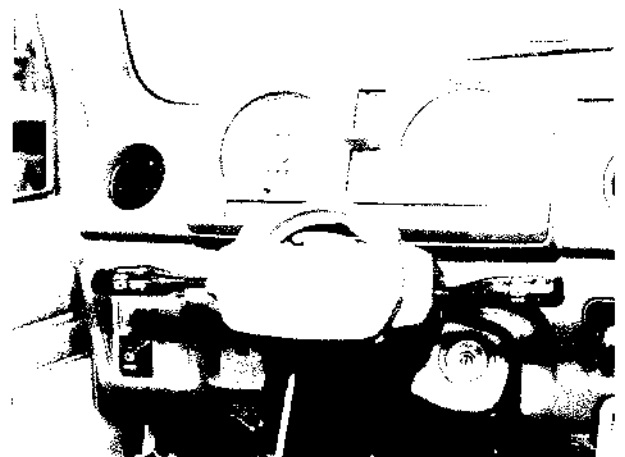


Fig. 18-5



Fig. 18-6

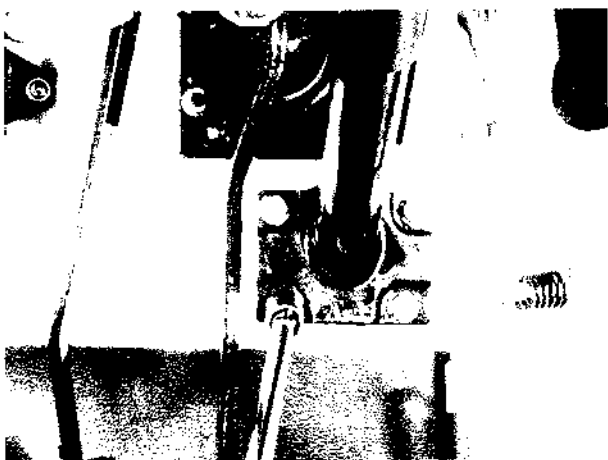


Fig. 18-7

2) Disconnect combination switch couplers and remove combination switch.



Fig. 18-8

3) Remove the bolt joining steering shafts in engine room.

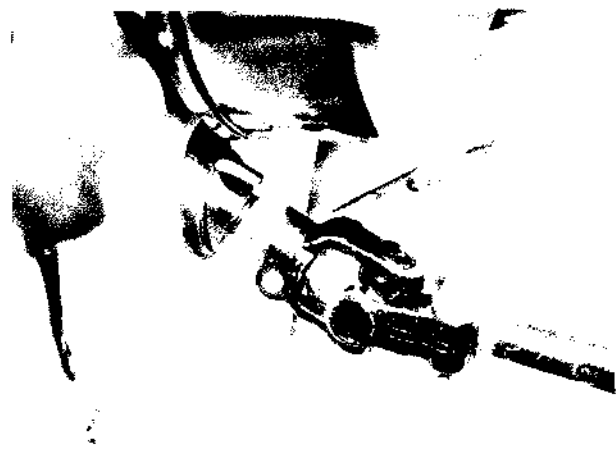


Fig. 18-9

4) Remove steering column ass'y.

**NOTICE:**

- Don't separate steering column assembly into steering column and shaft. If column or shaft is defective, replace as an assembly.

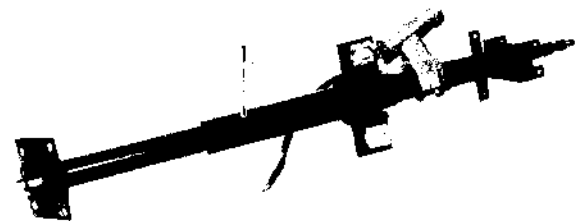


Fig. 18-10

1. Steering column ass'y

### Steering Lock

- 1) After removing steering column, loosen and remove steering lock mounting bolts. Use care not to damage aluminum part of steering lock body with center punch.

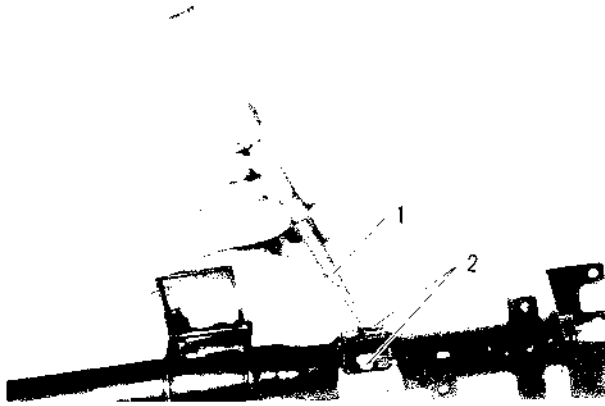


Fig. 18-11 1. Center punch (with sharp point)  
2. Steering lock mounting bolts

- 2) Remove steering lock assembly from steering column.

### Gear Box

- 1) Remove joint bolt.



Fig. 18-12

- 2) Remove radiator under cover, and disconnect ball stud of drag rod using special tool and steering damper from pitman arm.

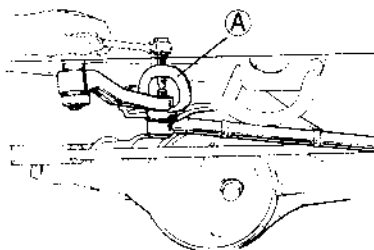


Fig. 18-13 (A) Special tool (Tie-rod end remover 09913-65210)

- 3) Steering gear box is secured in place by mounting bolts. Remove these bolts and take down gear box.

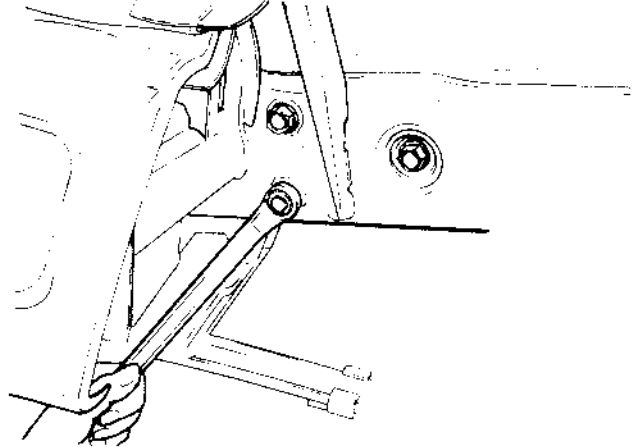


Fig. 18-14

### Tie Rod and Tie Rod End

- 1) Hoist car and remove wheels.
- 2) Remove drag rod castle nut, and then remove tie rod and tie rod end using special tool.

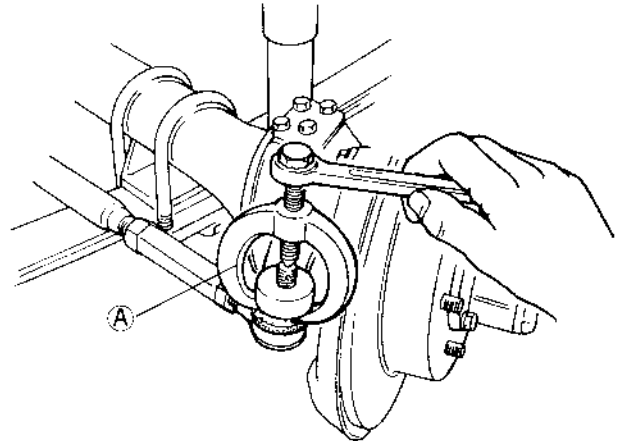
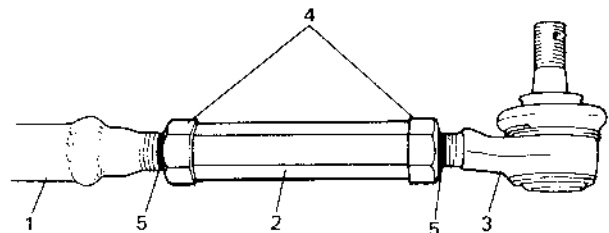


Fig. 18-15 (A) Special tool (Tie-rod end remover 09913-65210)

- 3) For ease of adjustment after installation, mark tie rod and tie rod end to indicate lock nut positions. Then loosen each lock nut and separate tie rod and tie rod end.



1. Tie rod
2. Turnbuckle
3. Tie rod end
4. Lock nut
5. Marking to be made

Fig. 18-16

## 18-5. INSPECTION OF COMPONENTS

### Steering Gear Box

[Oil level]

Oil surface should be up to the level as shown in below figures. If not, add prescribed gear oil, SAE 90.

Right hand steering vehicle

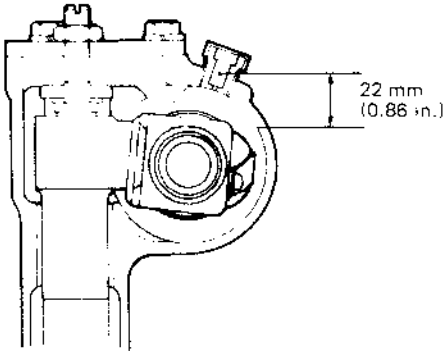


Fig. 18-17

Left hand steering vehicle

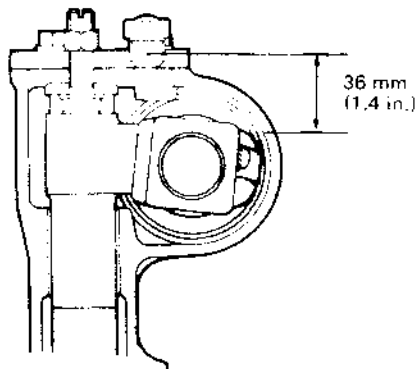


Fig. 18-18

[Adjustment of worm shaft starting torque]  
The steering gear box is provided with adjusting bolt ① which gives preload to sector shaft.

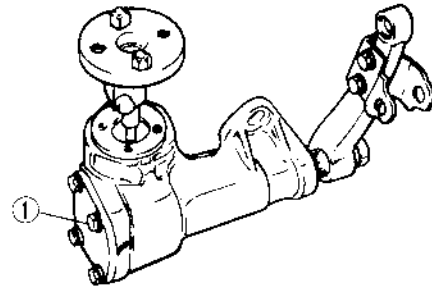


Fig. 18-19 ① Adjusting bolt

Make an adjustment according to the following procedure.

- 1) Check worm shaft to ensure that it is free from thrust play.
- 2) Position pitman arm in parallel with worm shaft as shown below.  
(With pitman arm in this position, front wheel is in straightforward state.)

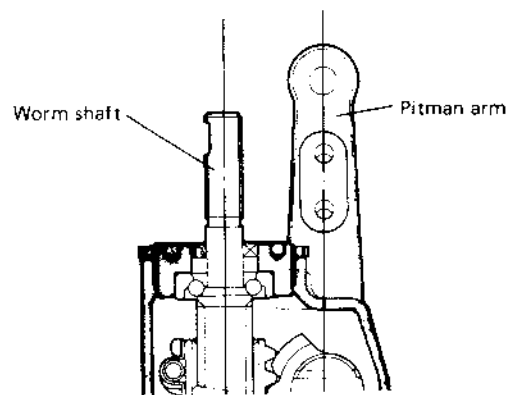
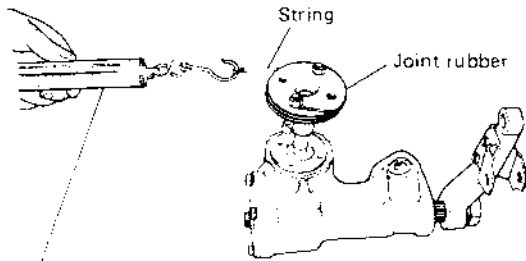


Fig. 18-20

3) Measure worm shaft starting torque from its position in the straightforward state in 2), using a spring balance and string as shown in below figure.



Spring balance (Use one with a maximum measurement of around 5 kg (11 lb.))

Fig. 18-21

Worm shaft (including sector shaft) starting torque (with torque wrench)	Right-hand steering vehicle 7.5 – 13.0 kg-cm (0.54 – 0.94 lb-ft)
	Left-hand steering vehicle 6.0 – 10.0 kg-cm (0.43 – 0.72 lb-ft)

Worm shaft (including sector shaft) starting torque (with spring balance)	Right-hand steering vehicle 1.97 – 3.42 kg (4.34 – 7.53 lb)
	Left-hand steering vehicle 1.58 – 2.63 kg (3.48 – 5.80 lb)

If measured torque is not within the specification, carry out adjustment with adjusting bolt ① to meet specification and check to confirm it again.

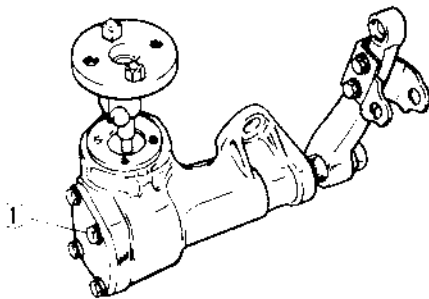


Fig. 18-22

4) If worm shaft starting torque is checked all right, another check should be carried out on worm shaft operating torque in its entire operating range (turning the worm shaft all the way to the right and left) as shown in Fig. 18-21.

Worm shaft (including sector shaft) operating torque (with torque wrench)	Right-hand steering vehicle Under 13.0 kg-cm (Under 0.94 lb-ft)
	Left-hand steering vehicle Under 12.0 kg-cm (Under 0.86 lb-ft)

Worm shaft (including sector shaft) operating torque (with spring balance)	Right-hand steering vehicle Under 3.42 kg (Under 7.53 lb)
	Left-hand steering vehicle Under 3.15 kg (Under 6.96 lb)

If measured torque does not conform to specification, readjust worm shaft starting torque in straightforward state by means of adjusting bolt ①, and then recheck worm shaft operating torque.

If the specified value is not attained even after readjustment, it is advisable to replace the gear box with a new gear box ass'y.

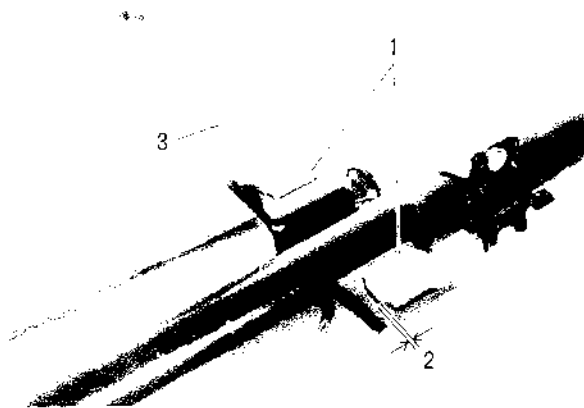


## 18-6. CHECKING STEERING COLUMN FOR ACCIDENT DAMAGE

Cars involved in accidents resulting in body damage or where the steering column has been impacted may also have a damaged or misaligned steering column.

### Checking Procedure

1) Check capsules on steering column bracket; all should be within 1.0 mm (0.039 in) from the bottom of slots. If not, steering column assembly should be replaced. Use thickness gauge for convenience.



- |   |  |
|---|--|
| <p>1. Capsules<br/>Each capsule should be within 0 – 1.0 mm (0 – 0.039 in.) from the bottom of slot. If not, replace column assembly.</p> | <p>2. Within 0 – 1.0 mm (0 – 0.039 in)</p> <p>3. Thickness gauge</p> |
|---|--|

Fig. 18-23

2) Take measurement "A" as shown. If it is shorter than specified length, replace column assembly with new one.

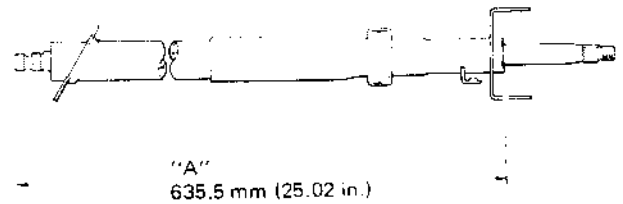


Fig. 18-24

3) Take measurement "B" of steering lower shaft as shown. If it is shorter than specified length, replace it with new one.

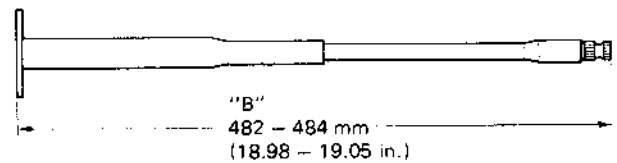


Fig. 18-25

4) Check steering shaft joints and shaft for any damages such as crack, breakage, malfunction or excessive play. If anything is found faulty, replace.

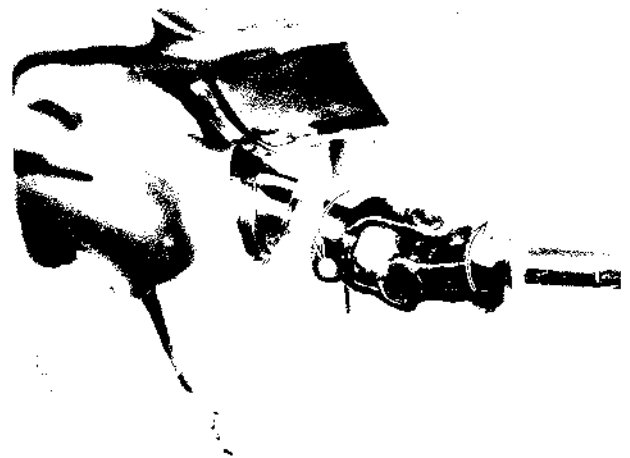


Fig. 18-26

5) Check steering shaft for smooth rotation. If found defective, replace as column assembly.

## 18-7. IMPORTANT STEPS IN REINSTALLATION

### NOTICE:

For installation, it is important that only the specified screws, bolts, and nuts be used as designated and that they are tightened to the specified torque.

Reverse removal procedure for installation, noting the following.

### Steering Lock

1) Position groove of steering shaft in the center of hole in column.

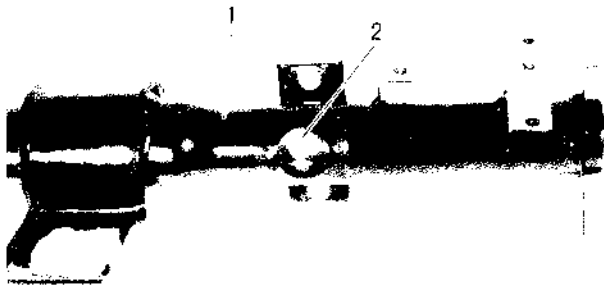


Fig. 18-27 1. Steering column  
2. Steering shaft

2) Align hub on steering lock with groove of steering shaft and rotate shaft to assure that steering shaft is locked.

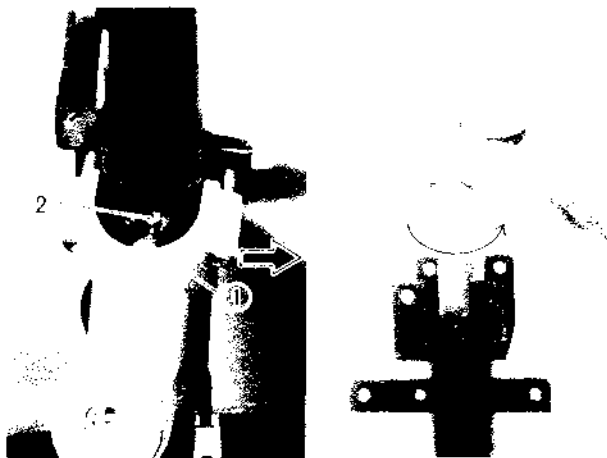


Fig. 18-28 1. Hub  
2. Groove

3) Tighten 2 new bolts until head of each bolt is broken off.

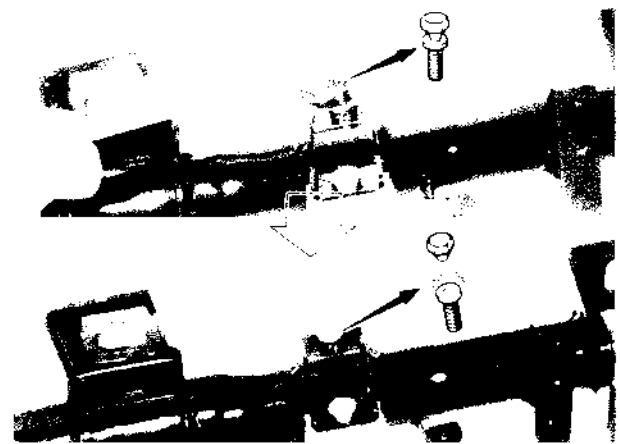


Fig. 18-29

4) Turn ignition key to "ACC" or "ON" position and check to be sure that steering shaft rotates smoothly. Also check for lock operation.

5) Install steering column. Refer to p. 18-14.

### Steering Gear Box

Put steering gear box bolts through from inside of car and tighten nuts to specified torque.

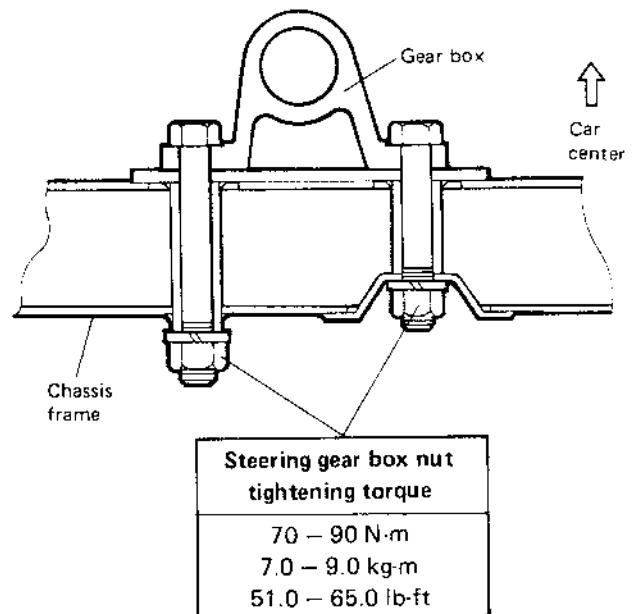


Fig. 18-29-1

### Steering Damper

- Install steering damper with larger diameter hole end directed toward pitman arm and hole in outer shell downward.
- Install steering damper stay, directing its circular boss side upward.
- Mount steering damper and steering damper stay bolts from the top.
- Torque steering damper pin nut and damper nut to specification while directing steering to straightforward state (with pitman arm in parallel with center line of car).

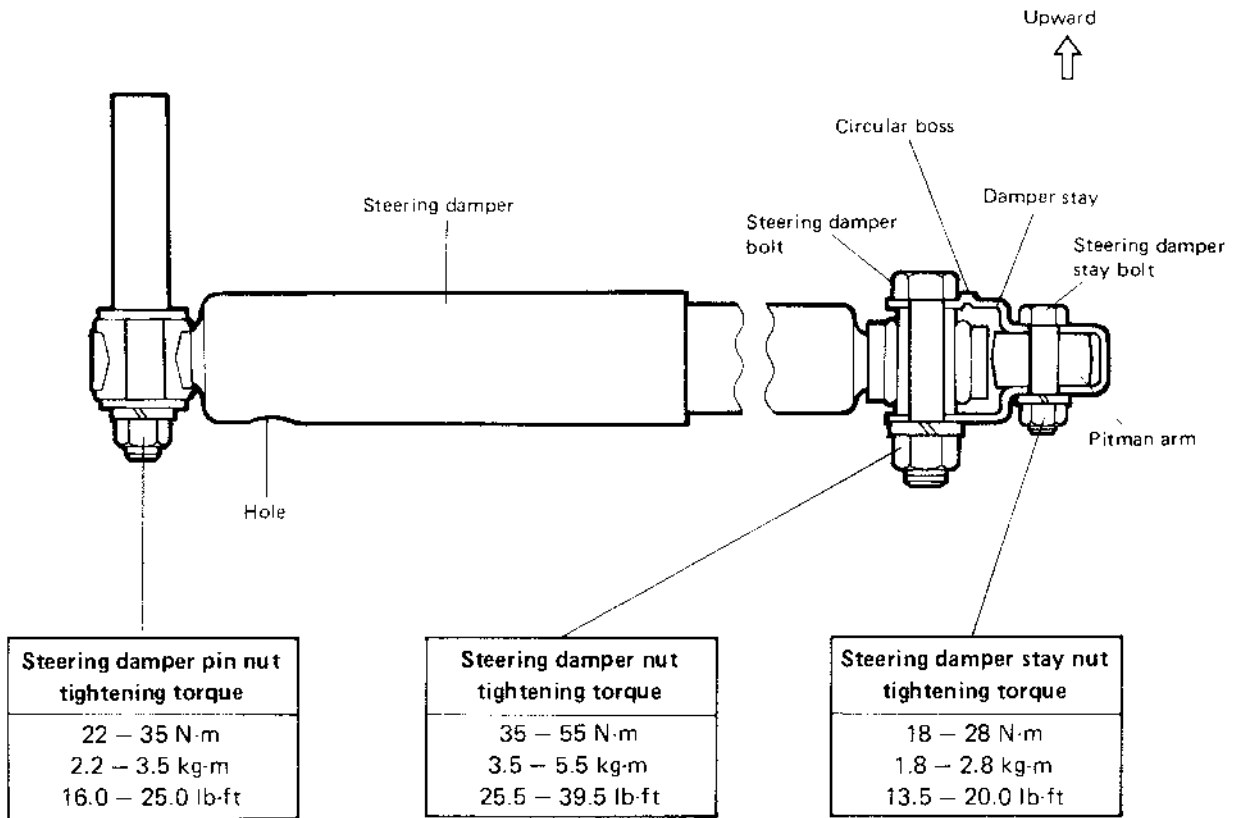


Fig. 18-29-2

# Steering Column

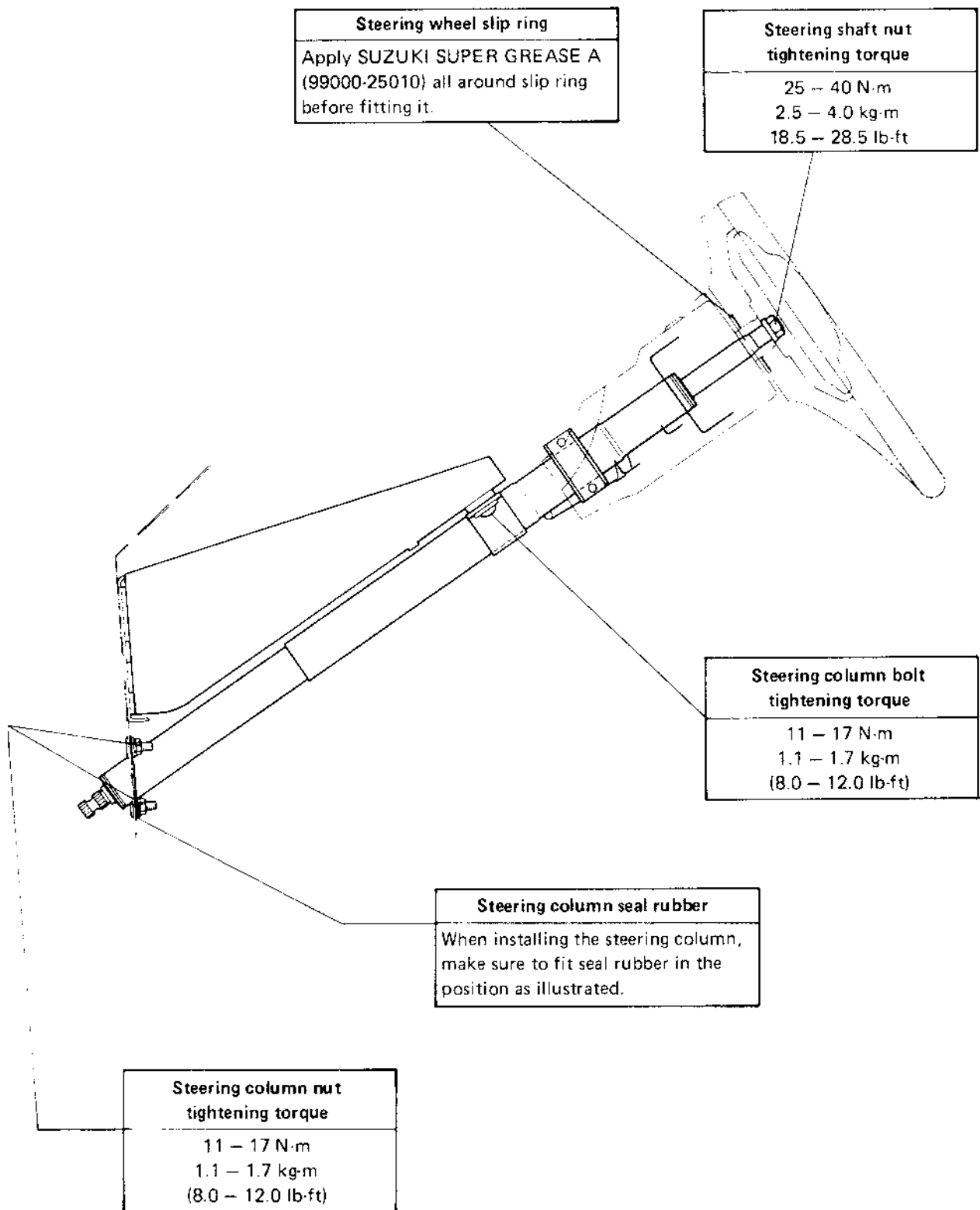


Fig. 18-30

# Steering Lower Shaft and Joint

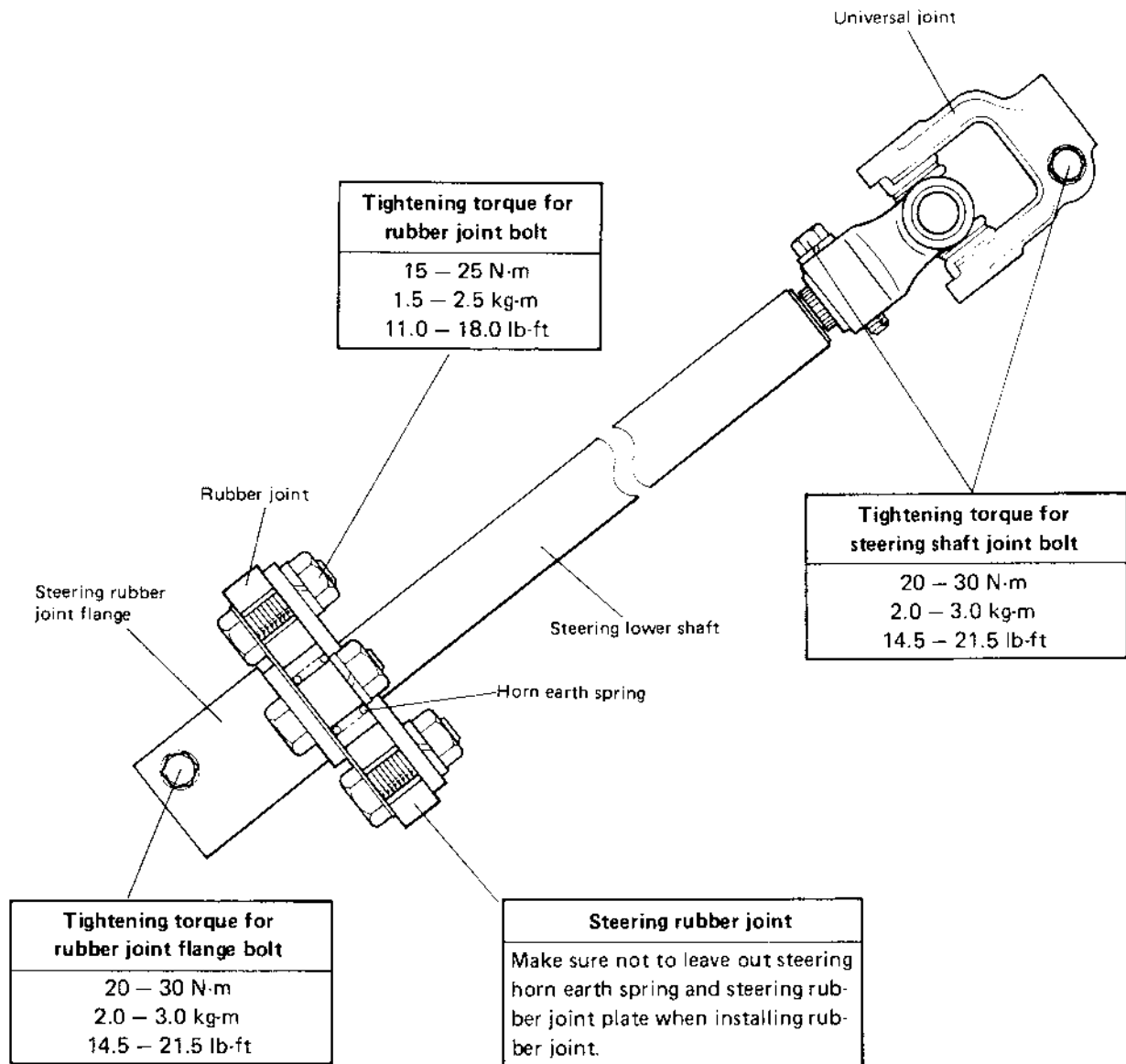


Fig. 18-31

### Steering Handwheel

Two requirements must be met, among others, in installing and setting steering wheel: 1) check to be sure that handwheel play meets specification, and 2) set it in such a way that, with front wheels in straightforward state, its two spokes are horizontal.

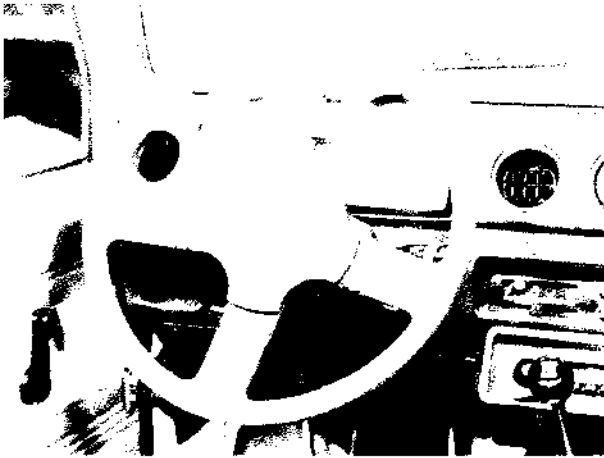
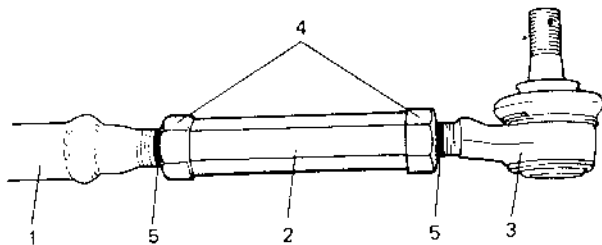


Fig. 18-32

### Tie Rod and Tie Rod End

1) Install tie rod end to tie rod, aligning each lock nut to respective marks scribed before disassembly.



1. Tie rod
2. Turnbuckle
3. Tie rod end
4. Lock nut
5. Marking to be made

Fig. 18-33

- 2) Connect tie rod end to knuckle and tie rod to drag rod. Tighten castle nut until holes for split pin are aligned, but only within specified torque.
- 3) Bend split pin.
- 4) Inspect for proper toe (Refer to 18-8 WHEEL ALIGNMENT).
- 5) After confirming proper toe, tighten tie rod end lock nuts to specified torque.

## 18-8. WHEEL ALIGNMENT

Front alignment refers to the angular relationship between the front wheels, the front suspension attaching parts and the ground. Generally, the only adjustment required for front alignment is toe setting. Camber and caster can't be adjusted. Therefore, should camber or caster be out of specification due to the damage caused by hazardous road conditions or collision, whether the damage is in chassis frame (body) or in suspension should be determined and damaged body should be repaired or damaged suspension should be replaced.

### Toe Setting

Toe is the turning in or out of the front wheels. The purpose of a toe specification is to ensure parallel rolling of the front wheels (Excessive toe-in or toe-out may increase tire wear). Amount of toe can be obtained by subtracting "A" from "B" as shown in figure and therefore is given in mm (in.).

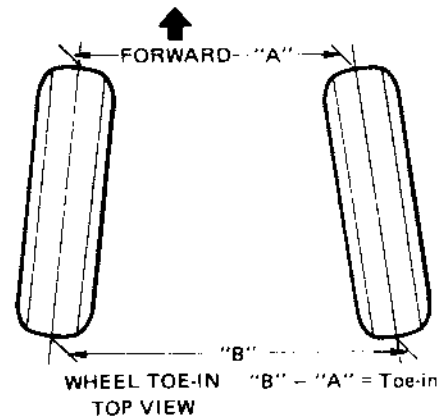


Fig. 18-34

## Camber

Camber is the tilting of the front wheels from the vertical, as viewed from the front of the car. When the wheels tilt outward at the top, the camber is positive. When the wheels tilt inward at the top, the camber is negative. The amount of tilt is measured in degrees.

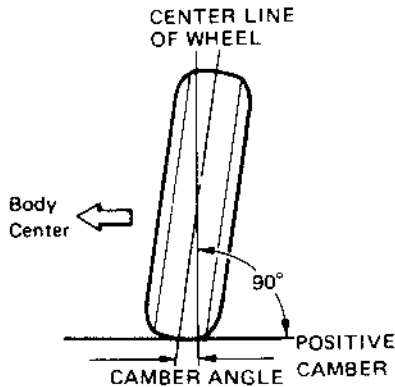


Fig. 18-35

## Toe Adjustment

1. Before making any adjustment affecting toe setting, the following checks and inspections should be made to insure correctness of alignment readings and alignment adjustments:

- 1) Check all tires for proper inflation pressures and approximately the same tread wear.
- 2) Check steering and suspension system for looseness. If excessive looseness is noted, it must be corrected before adjusting.
- 3) Check for run-out of wheels and tires.
- 4) Consideration must be given to excess loads, such as tool boxes. If this excess load is normally carried in the car, it should remain in the car during alignment checks.
- 5) Consider condition of the equipment being used to check alignment and follow manufacturer's instructions.
- 6) Regardless of equipment used to check alignment, the car must be on a level surface both fore and aft and transversely.
- 7) Check to be sure that front wheels are set in straightforward driving position.

2. Toe is adjusted by changing tie rod length. Loosen tie rod end lock nuts first and then rotate turnbuckle ① to align toe-in to specification. At this time, thread length "A" and "B" should be equal. After adjustment, tighten lock nuts to specified torque.

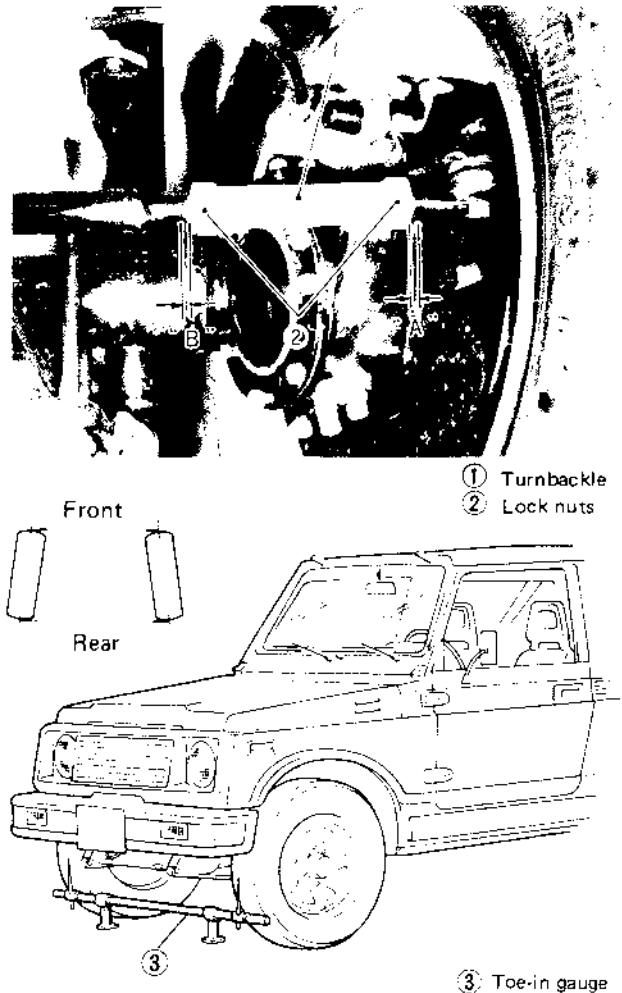


Fig. 18-36

## Camber and Caster Adjustment

Should camber or caster be found out of specifications upon inspection, locate its cause first. If it is in damaged, loose, bent, dented or worn suspension parts, they should be replaced. If it is in chassis frame (car body), repair it so as to attain specifications.

To prevent possible incorrect reading of camber or caster, car front end must be moved up and down a few times before inspection.

## Reference Information:

### SIDE SLIP:

For inspecting front wheel side slip with side slip tester:

Side slip limit:	Less than 3 mm/m (Less than 0.118 in/3 ft)
------------------	---

If side slip exceeds this limit, toe-in or front wheel alignment may not be correct.

## 18-9. MAINTENANCE SERVICES

### Steering Handwheel Play

The wheel play is proper if it is anywhere between 10 and 30 mm (0.4 and 1.2 in.). An unusually large play means that the ball-and-socket joints are loose or that the wear in the steering gear box is excessively large.

Replacement of the worn joint will provide a proper handwheel play.

If steering handwheel play is excessive though no each joint of steering system rattles, adjust worm shaft starting torque of steering gear box by referring to item of "Adjustment of worm shaft starting torque."

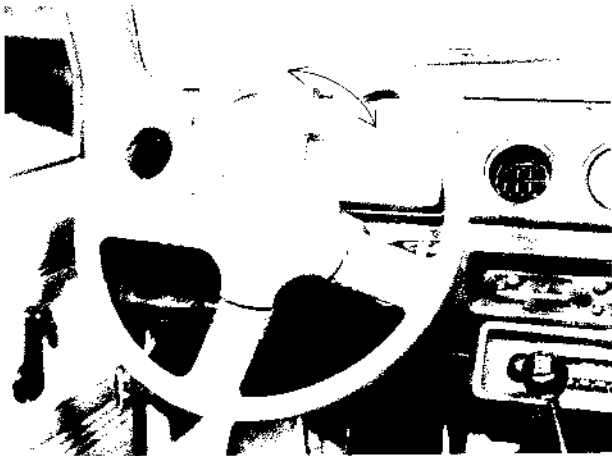


Fig. 18-37

### Steering Shaft Joint

Check universal joint of the steering shaft for rattle and damage. If rattle and damage is found, replace defective part with a new one.



Fig. 18-38

### Steering Rubber joint

Inspect rubber joint for evidence of crack or breakage, and make sure that its bolts are tight.

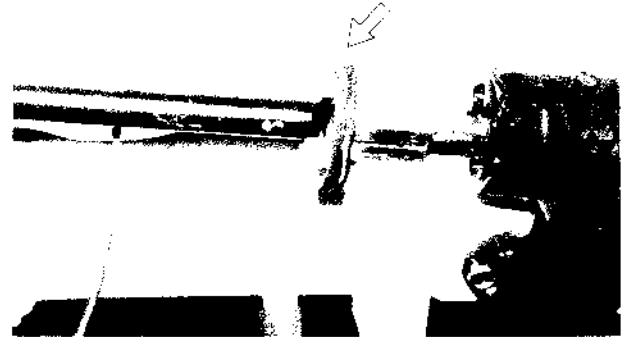


Fig. 18-39

### Steering Link & Tie Rod

Inspect steering link and tie rod for bend and rattle where they are joined. Inspect ball joint boots in steering system for leaks, detachment, tear or other damage. If one of such malconditions is found, replace defective part with a new one.

Check the following bolts and nuts ( ① - ⑦ ) for tightness and retighten them as necessary.

Refer to "RECOMMENDED TORQUE SPECIFICATIONS" in this section for tightening torque.

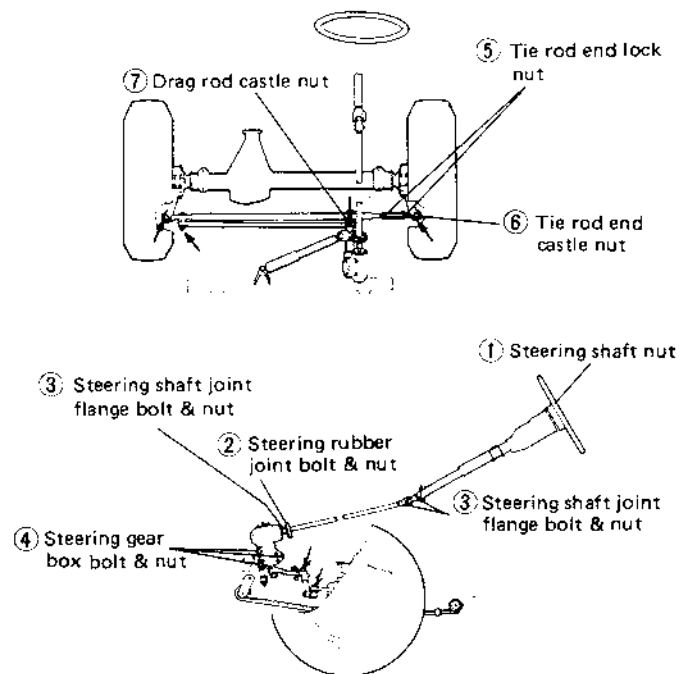


Fig. 18-40



### Steering Gear Box

Check steering gear box for evidence of oil leakage. If leakage is found, repair or replace and then refill specified oil to specified level.

Refer to "18-5 INSPECTION OF COMPONENT" in this section for steering gear box oil.

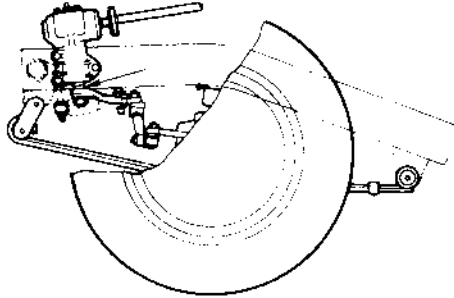


Fig. 18-41

### Tires

When replacement is necessary, the original equipment type tire should be used. Refer to Tire Placard.

Replacement tires should be of the same size, load range and construction as those originally on the car. Use of any other size or type tire may affect ride, handling, speedometer/odometer calibration, vehicle ground clearance and tire or snow chain clearance to body and chassis.

#### NOTICE:

Do not mix different types of tires on the same car such as radial, bias and bias-belted tires except in emergencies, because car handling may be seriously affected and may result in loss of control.

It is recommended that new tires be installed in pairs on the same axle. If necessary to replace only one tire, it should be paired with the tire having the most tread, to equalize braking traction.

#### [Inspection]

- Check tires for uneven or excessive wear, or damage. If defective, replace.
- Check inflating pressure of each tire and, as necessary, adjust pressure to specification.
- Check wheels for dent, crack or other damage.
- Check wheel nuts for tightness.

Tightening torque for wheel nuts	50 – 80 N·m
	5.0 – 8.0 kg·m
	(36.5 – 57.5 lb·ft)

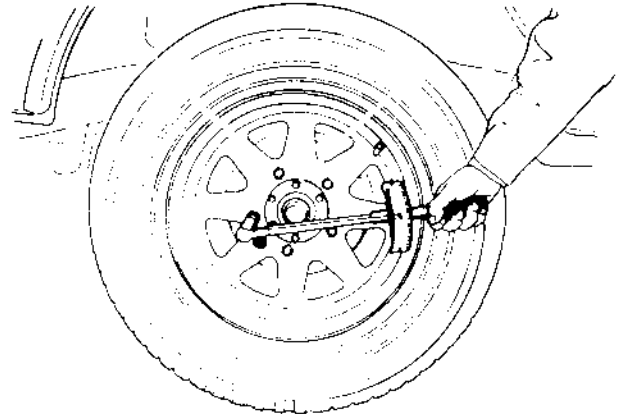


Fig. 18-42

#### [Tire wear indicator]

Check wear indicator, and replace tire when its wear is the same level as the indicator.

Tire service limit	Less than 1.6 mm (0.063 in.) depth of tread at two places.
--------------------	--

#### NOTICE:

The mud & snow tire has a platform to indicate wear in addition to tire tread wear indicator. It shows up when 50% of tire tread is worn out. When driving on muddy or snowy roads, check if its wear is the same level as the platform and if it does, replace the tire.

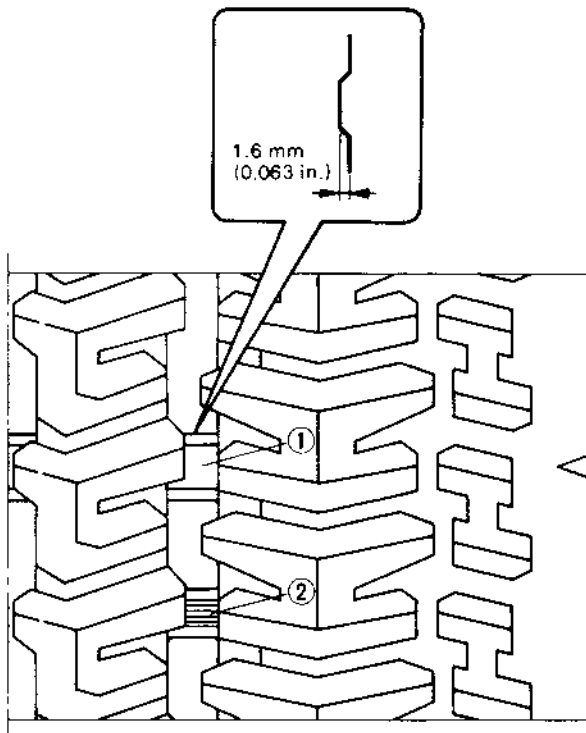


Fig. 18-43 ① Tire tread wear indicator  
② Wear indicating platform

[Inflation of tires]

- Tire inflation pressures are listed on the Tire Placard at driver's side of instrument panel.
- Tire inflation pressures should be checked (including spare tire) at least monthly and when significantly changing the load in the car.
- Always check tire inflation pressures when tires are "cold".
- Always use tire pressure gauge when checking inflation pressure.
- Be sure to reinstall tire inflation valve caps to prevent dirt and moisture from getting into valve core, as they may cause air leakage.
- If air loss occurs while driving, do not drive on the deflated tire more than is needed to stop safely. Driving even a short distance on a deflated tire can damage a tire and wheel beyond repair.

[Tire rotation]

"Rotate" tires at the regular intervals in order to equalize tire wear and thereby make full use of each tire. Refer to below figure for the scheme of rotation. Adherence to this scheme prolongs tire life.

**NOTICE:**

Before installing wheels, remove any build-up of corrosion on the wheel mounting surface and brake drum or disc mounting surface by scraping and wire brushing. Installing wheels without good metal-to-metal contact at the mounting surfaces can cause wheel nuts to loosen, which can later allow a wheel to come off while the car is moving.

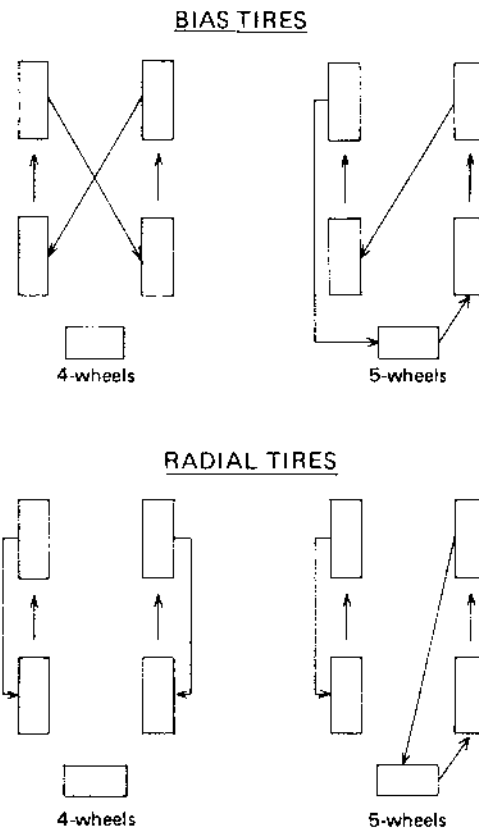
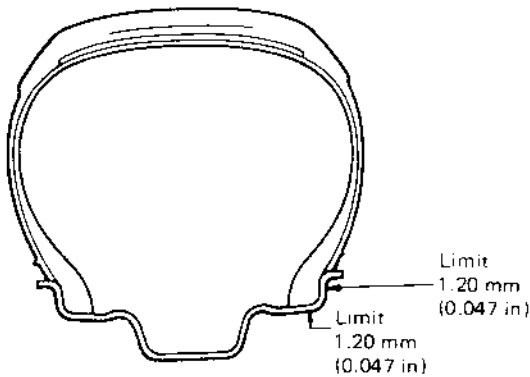


Fig. 18-44

[Wheels]

Wheels must be replaced if they are bent, dented, have excessive lateral or radial runout, leak air through welds, have elongated bolt holes, if lug nuts won't stay tight, or if they are heavily rusted. Wheels with greater runout than shown in below figure may cause objectional vibrations. Replacement wheels must be equivalent to the original equipment wheels in load capacity, diameter, rim width, offset and mounting configuration. A wheel of improper size or type may affect wheel and bearing life, brake cooling, speedometer/odometer calibration, car ground clearance and tire clearance to the body and chassis.



\*TOTAL INDICATOR READING  
 IGNORE INDICATOR "JUMPS"  
 DUE TO WELD SEAMS, PAINT  
 RUNS, SCRATCHES, ETC.

Fig. 18-45

Wheel repairs that use welding, heating, or peening are not approved. All damaged wheels should be replaced.

[Tire demounting and mounting]

Use a tire changing machine to mount or demount tires. Follow the equipment manufacturer's instructions. Do not use hand tools or tire irons alone to change tires as they may damage the tire beads or wheel rim.

Rim bead seats should be cleaned with a wire brush or coarse steel wool to remove lubricants, old rubber and light rust. Before mounting or demounting a tire, the bead area should be well lubricated with an approved tire lubricant.

After mounting, inflate to 220 kPa (32 psi) so that beads are completely seated.

**IMPORTANT:**  
 Do not stand over tire when inflating. Bead may break when bead snaps over rim's safety hump and cause serious personal injury.  
 Do not exceed 240 kPa (35 psi) pressure when inflating. If 220 kPa (32 psi) pressure will not seat beads, deflate, re-lubricate and reinflate. Over inflation may cause the bead to break and cause serious personal injury.

Inflate to specified pressure.

[Tire repair]

There are many different materials and techniques on the market to repair tires. As not all of these work on all types of tires, tire manufacturers have published detailed instructions on how and when to repair tires. These instructions can be obtained from the tire manufacturer.

## 18-10. RECOMMENDED TORQUE SPECIFICATIONS

Fastening parts	Tightening torque		
	N·m	kg·m	lb·ft
Steering shaft nut	25 – 40	2.5 – 4.0	18.5 – 28.5
Steering shaft rubber joint bolt	15 – 25	1.5 – 2.5	11.0 – 18.0
Steering shaft joint flange bolt	20 – 30	2.0 – 3.0	14.5 – 21.5
Steering gear box nut	70 – 90	7.0 – 9.0	51.0 – 65.0
Drag rod castle nut	30 – 70	3.0 – 7.0	22.0 – 50.5
Tie rod end castle nut	30 – 55	3.0 – 5.5	22.0 – 39.5
Tie rod end lock nut	70 – 100	7.0 – 10.0	51.0 – 72.0
Steering damper stay nut	18 – 28	1.8 – 2.8	13.5 – 20.0
Steering damper nut	35 – 55	3.5 – 5.5	25.5 – 39.5
Steering damper pin nut	22 – 35	2.2 – 3.5	16.0 – 25.0
Steering column bolt & nut	11 – 17	1.1 – 1.7	8.0 – 12.0

## SECTION 19

# BRAKES

### CONTENTS

19-1. GENERAL DESCRIPTION .....	19-2
19-2. FRONT DISC BRAKE .....	19-14
19-3. REAR DRUM BRAKE .....	19-20
19-4. MASTER CYLINDER .....	19-27
19-5. BRAKE BOOSTER .....	19-30
19-6. PARKING BRAKE .....	19-38
19-7. BRAKE PIPES AND HOSES .....	19-39
19-8. MAINTENANCE SERVICE .....	19-42
19-9. TORQUE SPECIFICATION .....	19-49

#### NOTICE:

All brake fasteners are important attaching parts in that they could affect the performance of vital parts and systems, and/or could result in major repair expense. They must be replaced with one of same part number or with an equivalent part if replacement becomes necessary. Do not use a replacement part of lesser quality or substitute design. Torque values must be used as specified during reassembly to assure proper retention of all parts. There is to be no welding as it may result in extensive damage and weakening of the metal.

#### IMPORTANT:

When servicing wheel brake parts, do not create dust by grinding, sanding brake linings, or by cleaning wheel brake parts with a dry brush or with compressed air. Many wheel brake parts contain asbestos fibers which can become airborne if dust is created during servicing. Breathing dust containing asbestos fibers may cause serious bodily harm. A water dampened cloth or water based solution should be used to remove any dust on brake parts. Equipment is commercially available to perform this washing function. These wet methods will prevent asbestos fibers from becoming airborne.

## 19-1. GENERAL DESCRIPTION

When the foot brake pedal is depressed, hydraulic pressure is developed in the master cylinder to actuate pistons (two in front and four in rear).

The master cylinder is a tandem master cylinder. Two brake pipes are connected to the master cylinder and they make two independent circuits. One connects the front right & rear left brakes and the other connects the front left & rear right brakes.

The proportioning valve (P valve) is included in these circuits between the master cylinder and rear wheels. In this brake system, the disc brake type is used for the front wheel brake and a drum brake type (leading/trailing shoes) for the rear wheel brake.

The parking brake system is mechanical. It applies brake force to only rear wheels by means of the cable and mechanical linkage system. The same brake shoes are used for both parking and foot brakes.

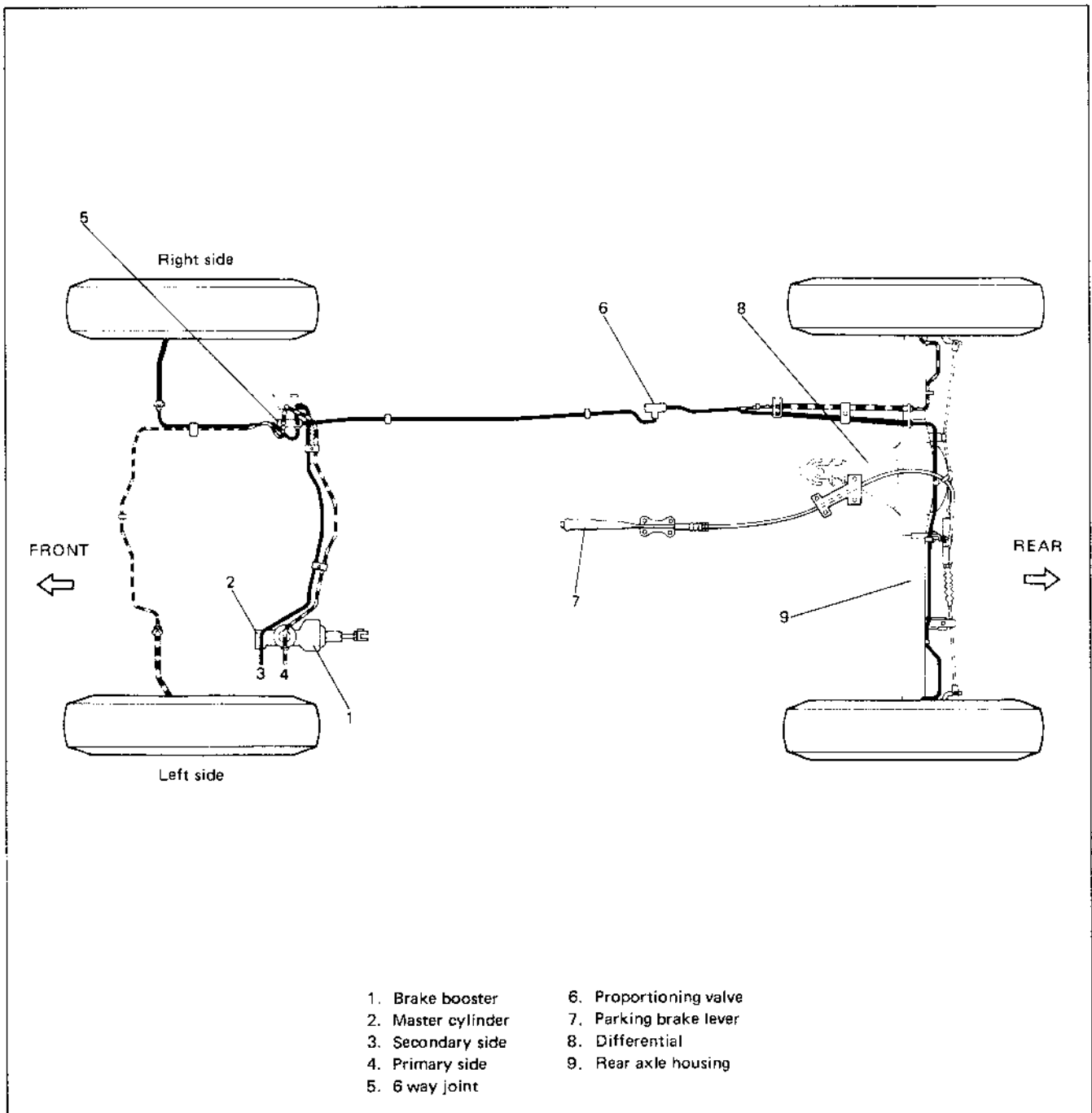
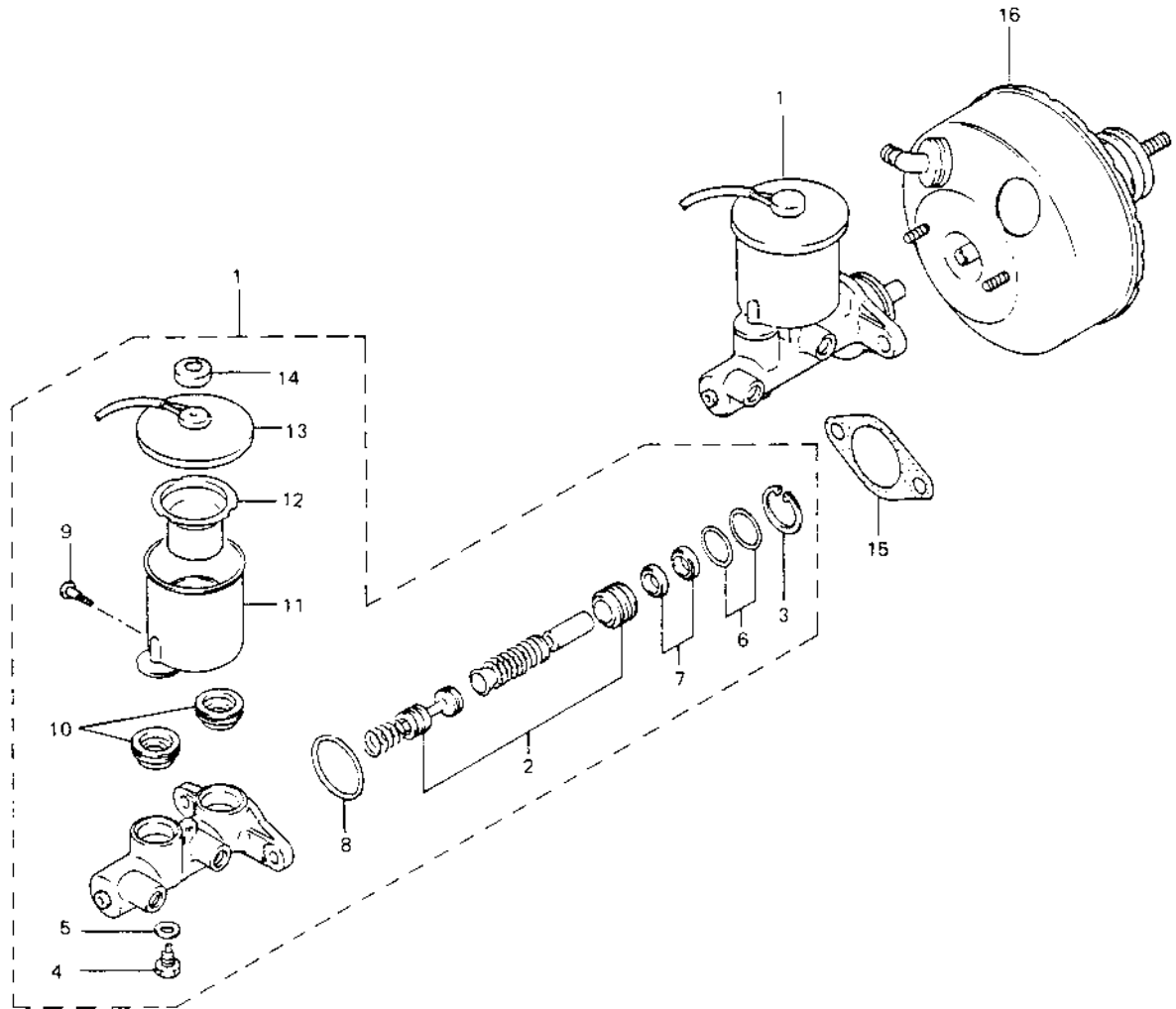


Fig. 19-1

# MASTER CYLINDER



1. Brake master cylinder assembly
2. Brake master cylinder piston set
3. Piston stopper circlip
4. Secondary piston stopper bolt
5. Seal ring
6. Piston stopper seal ring
7. Cylinder cup
8. Master cylinder seal ring
9. Connector screw
10. Reservoir connector grommet
11. Master cylinder reservoir
12. Cylinder reservoir strainer
13. Cylinder reservoir cap
14. Breather cap
15. Master cylinder gasket
16. Brake booster assembly

Fig. 19-2

## MASTER CYLINDER ASSEMBLY

### [GENERAL DESCRIPTION]

The master cylinder has two pistons and three piston cups. Its hydraulic pressure is produced in the primary ("a" in the below figure) and secondary ("b") chambers. The hydraulic pressure produced in the primary chamber ("a") acts on the left front wheel brake and right rear wheel brake. Also, the hydraulic pressure produced in the secondary chamber ("b") acts on the right front wheel brake and left rear wheel brake.

### NOTICE:

Replace all components included in repair kits to service this master cylinder. Lubricate rubber parts with clean, fresh brake fluid to ease assembly. Do not use lubricated shop air on brake parts as damage to rubber components may result. If any hydraulic component is removed or brake line disconnected, bleed the brake system. The torque values specified are for dry, unlubricated fasteners.

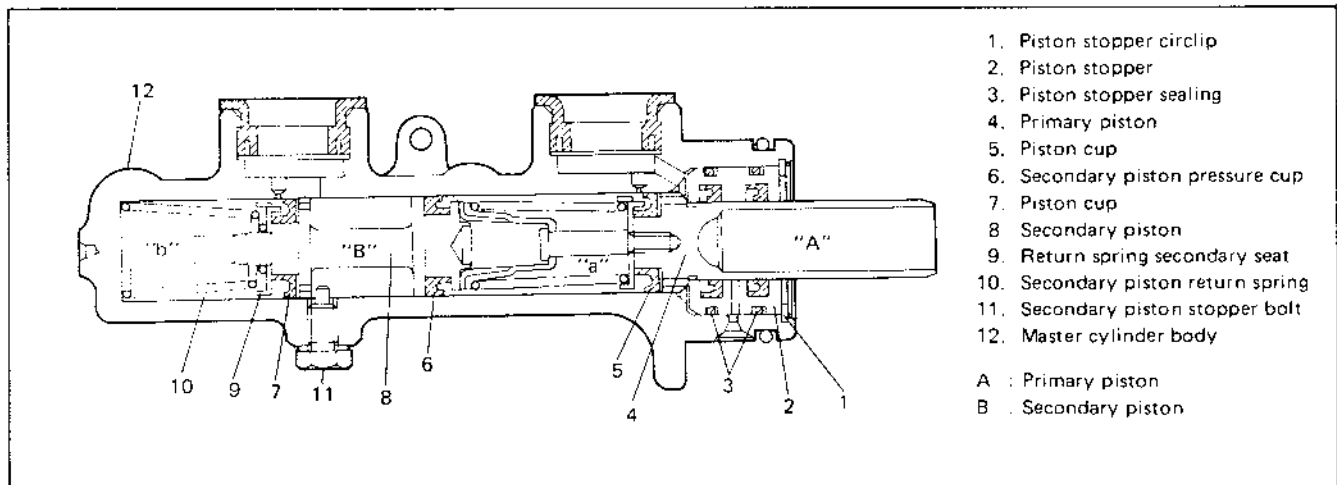


Fig. 19-3

### [Master cylinder OPERATION]

#### Normal operation

Depressing the brake pedal forces the primary piston "A" to move to the left in the below figure and consequently the hydraulic pressure is produced in the chamber "a".

By means of this pressure and the return spring force, the secondary piston "B" is also pushed to the left and thus the hydraulic pressure is produced in the chamber "b".

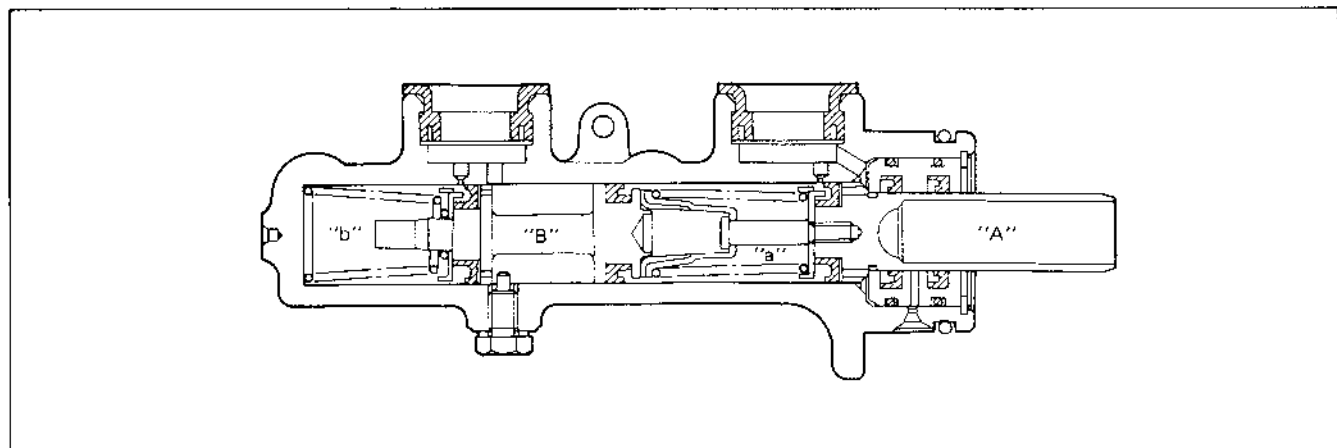


Fig. 19-3-1



**One-circuit operation (Primary chamber "a" circuit failure)**

Depressing the brake pedal forces the primary piston "A" to move as described previously, but since the brake circuit connected to the chamber "a" cannot hold the pressure, no pressure is produced in the fluid immediately ahead of the piston "A". The piston "A" keeps moving while compressing the spring and when it reaches the retainer, the piston "B" is pushed and begins to move. This causes the pressure to rise in the chamber "b" and the pressure acts on the right front wheel brake and left rear wheel brake.

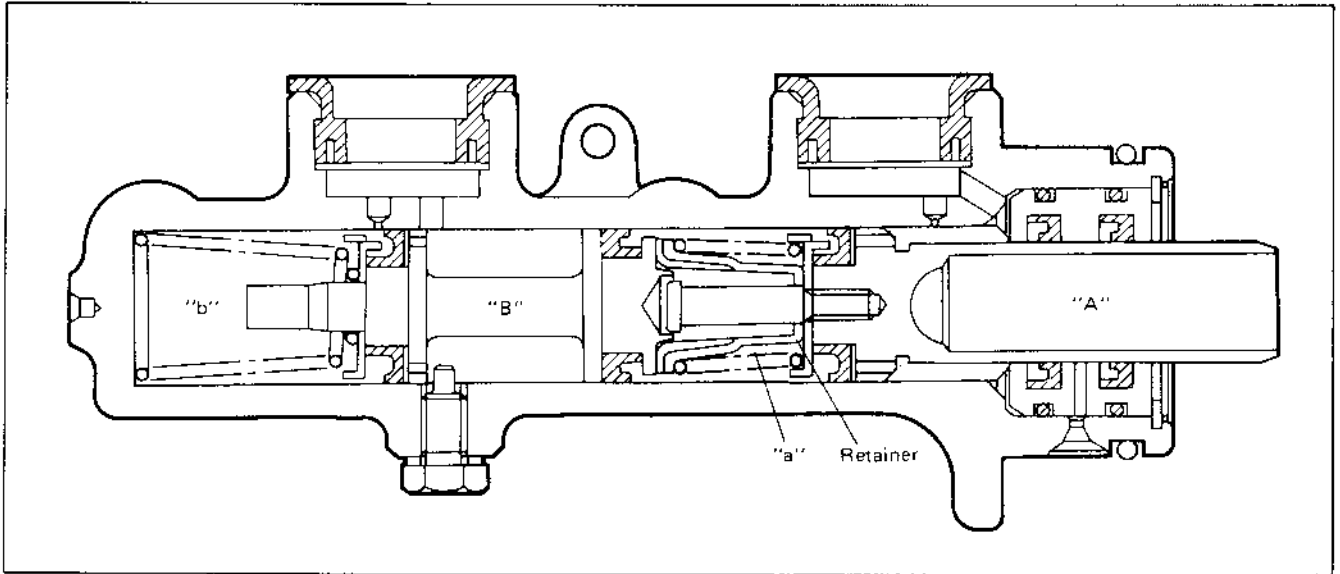


Fig. 19-4

**One-circuit operation (Secondary chamber "b" circuit failure)**

In this case, the leftward movement of the piston "A" has but little effect in causing the fluid pressure to rise in the chamber "a" in the beginning, because the initial rise of the fluid pressure causes the piston "B" to promptly yield and move to the left. However, when the forward end of the piston "B" comes to the head of the cylinder and stops there, the leftward movement of the piston "A" becomes effective. Thus the fluid pressure is produced in the chamber "a" and it acts on the left front wheel brake and right rear wheel brake.

The below figure shows secondary piston "B" at halt.

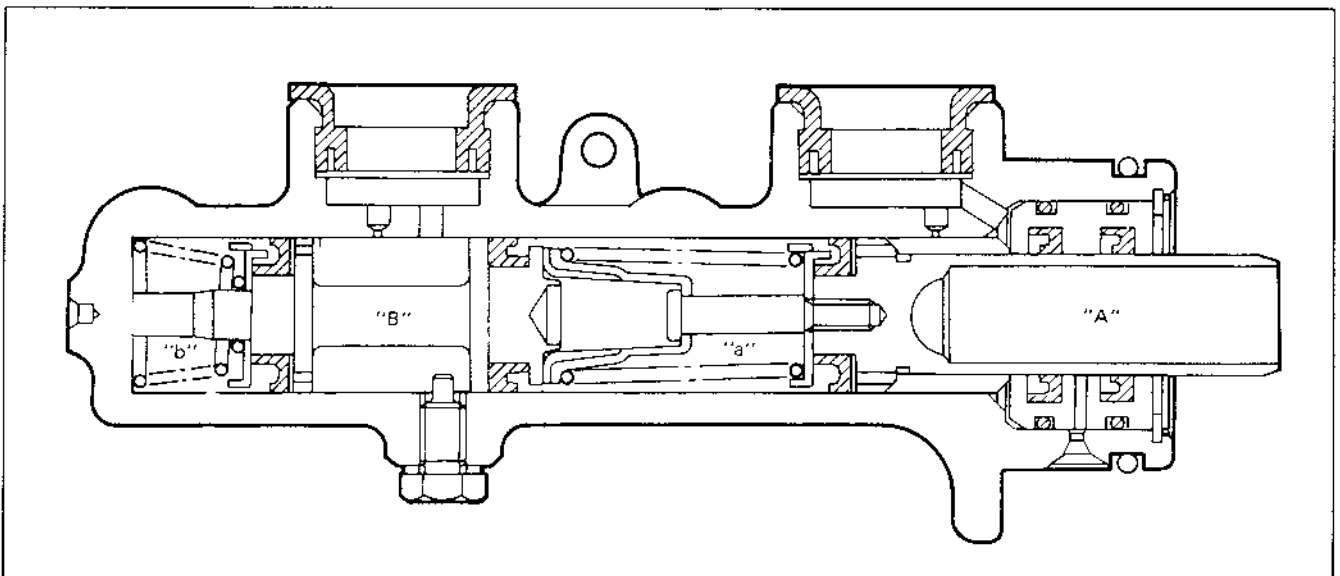


Fig. 19-4-1

## DISC BRAKE CALIPER ASSEMBLY

### [GENERAL DESCRIPTION]

This caliper has a single 51.1 mm (2.012 in.) bore and is mounted to the brake caliper holder with two mounting bolts. Hydraulic force, created by applying force to the brake pedal, is converted by the caliper to friction. The hydraulic force acts equally against the piston and the bottom of the caliper bore to move the piston outward and to move (slide) the caliper inward, resulting in a clamping action on the disc. This clamping action forces the pads (linings) against the disc, creating friction to stop the car.

For details, refer to OPERATION in the next page.

### NOTICE:

Lubricate parts as specified. Do not use lubricated shop air on brake parts as damage to rubber components may result. If any component is removed or line disconnected, bleed the brake system. Replace pads in axle sets only. The torque values specified are for dry, unlubricated fasteners.

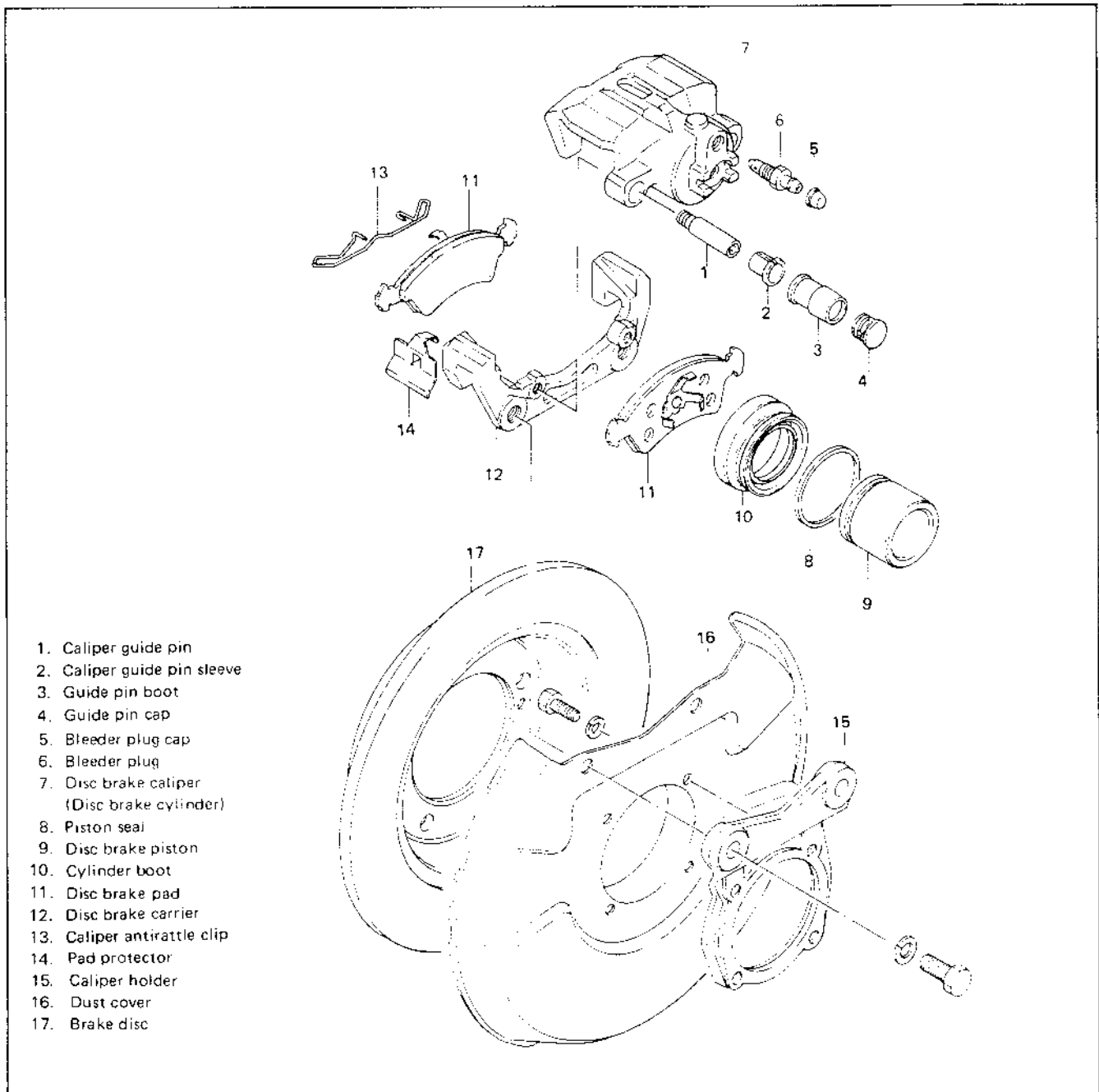


Fig. 19-5

## [Caliper OPERATION]

### Single piston floating caliper type

The single piston floating caliper type brake is employed in this model. One cylinder and one piston are used for this type. (The cylinder is constructed as a monoblock with the caliper.) Fluid pressure generated in the cylinder causes the pad (1) on the piston side to press against the disc. At the same time, the floating type caliper body is moved to the right by the cylinder pressure, as shown in below figure, which pulls pad (2) against the disc and so brakes the wheel.

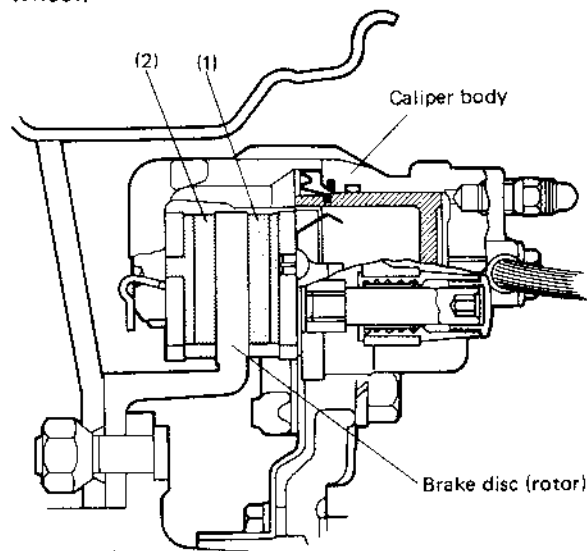
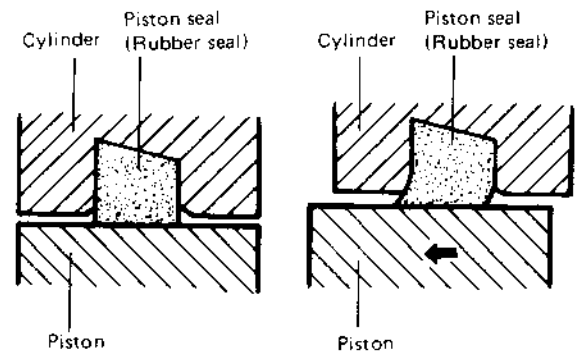


Fig. 19-6

The disc brake has no servo assistance as in drum braking, and it is necessary to increase the working pressure of the piston and pad. For this purpose, the wheel cylinder has a large bore. Even only a little change in clearance between the disc and pad has therefore a large influence on the brake pedal stroke. It is necessary to have the clearance adjusted to the minimum at all times, by means of the piston (rubber) seal.



Hydraulic pressure  
"OFF"

Hydraulic pressure  
"ON"

Fig. 19-7

### Clearance correction

When oil pressure is applied to the piston, the piston moves forward. The rubber seal, which exerts considerable pressure against the piston, moves with the cylinder. However, as a part of the rubber seal has been fixed into a groove in the cylinder, the shape of the rubber seal is distorted toward internal end of the cylinder, as shown in above figure. When pressure is taken off from the foot brake pedal and fluid pressure is released from the piston, a restoring force is generated at the seal and pushes the piston back. As the pads wear away and the clearance between the disc and pads becomes larger, the piston moves a larger distance. The seal then could change in shape further but, since the end of the seal is fixed into the groove in the cylinder, the distortion is limited to the same amount as previously described. The piston moves further to cover the distance of clearance. The piston returns by the same distance and the rubber seal recovers its shape as described above and thus the clearance between the disc and pads are maintained in adjustment.

## DRUM BRAKE ASSEMBLY (Rear Wheel Brake)

### [GENERAL DESCRIPTION]

The drum brake assembly has a self shoe clearance adjusting system so that drum-to-shoe clearance is maintained appropriate at all times. For details, refer to OPERATION in the next page.

### NOTICE:

Replace all components included in repair kits used to service this drum brake. Lubricate parts as specified.

### WARNING:

When servicing wheel brake parts, do not create dust by grinding or sanding brake linings or by cleaning wheel brake parts with a dry brush or with compressed air. (A water dampened cloth should be used.) Many wheel brake parts contain asbestos fibers which can become airborne if dust is created during servicing. Breathing dust containing asbestos fibers may cause serious bodily harm. If any hydraulic component is removed or brake line disconnected, bleed the brake system. The torque values specified are for dry, unlubricated fasteners.

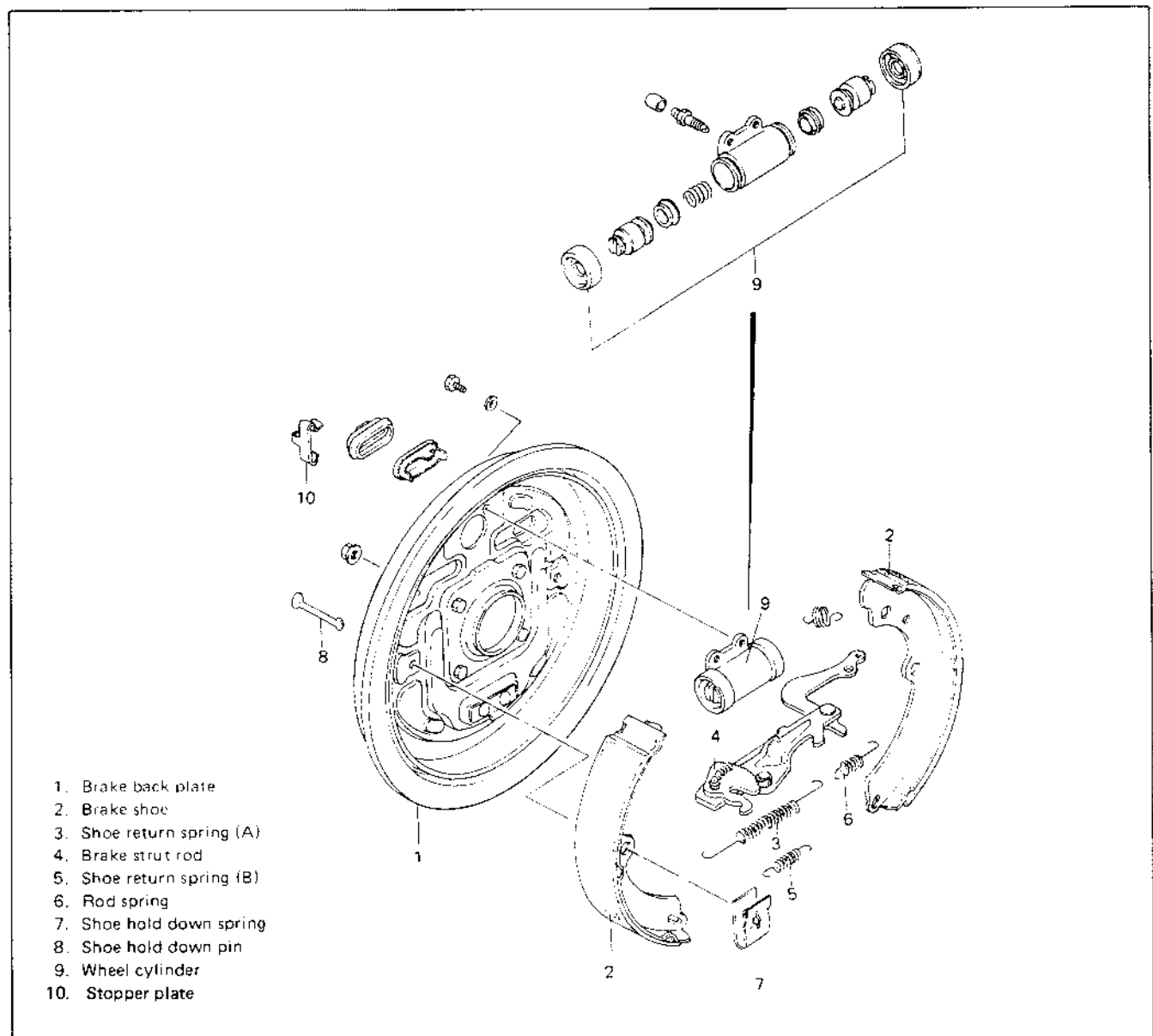


Fig. 19-8

### [Rear brake OPERATION]

With the general drum brake type, when the brake pedal is depressed, two pistons in the wheel cylinder force the brake shoes outward, restraining the turn of the drum.

The more the brake shoes get worn, the longer distance the pistons must move. As a result, the brake pedal travel (pedal-to-wall clearance) increases. Then the shoe clearance must be adjusted by the shoe adjusting screws. Thus periodical adjustment is required for the drum brake type in general.

This rear brake is provided with a self-adjusting system which automatically adjusts the shoe-to-drum clearance (pedal-to-wall clearance) caused by such brake shoe wear.

#### Clearance correction

In each rear wheel cylinder, pistons, piston cups, and a piston spring (1) are installed. When the brake pedal is depressed, fluid pressure is applied to the inside of the chamber on the piston (2), (3).

Being actuated by this pressure, the piston (2) moves to the left (piston (3) moves to the right) in the following figure and presses the brake shoe against the brake drum, thus producing brake force.

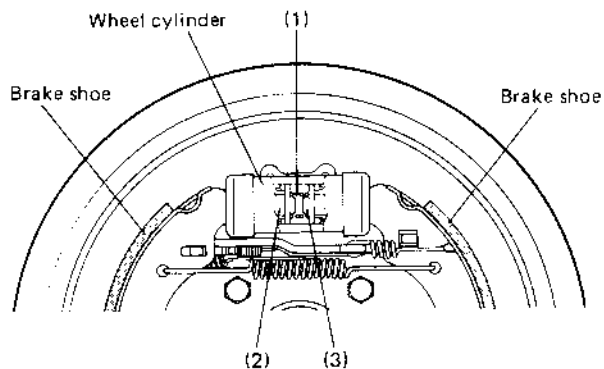


Fig. 19-9

At this time, the distance the brake shoe moves is "B", that is, the distance that "A" (the end of the long hole made in the brake shoes web) moves till it contacts the lever (1) which is fitted in the long hole.

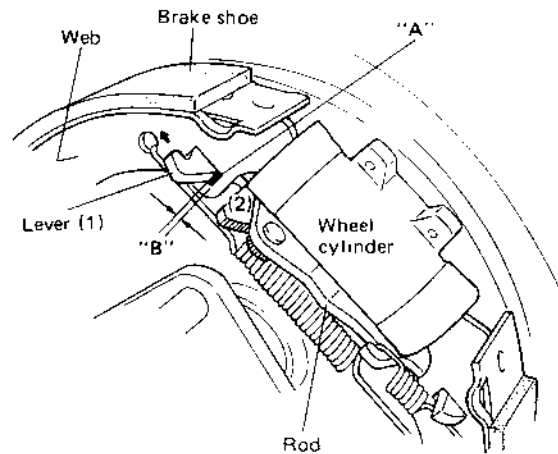


Fig. 19-10

When the brake pedal is depressed, the piston and brake shoe move toward the brake drum side by the aforementioned distance "B" and "A" of the brake shoe web contacts the lever (1). As the brake shoe gets worn and the brake shoe clearance becomes larger, the force applied to the lever (1) at the time of such a contact becomes larger. When it exceeds 10 – 12 kg (22 – 26 lbs), the "A" of the brake shoe web moves the lever (1) as much as the amount of the brake shoe lining wear toward the direction as shown with an arrow in the figure. Thus the shoe is forced against the drum and the brake force is produced.

The distance the lever (1) moves corresponds to the amount of wear. In accordance with the lever (1) movement, the fan-shaped ratchet (2) also moves, for they are assembled as a unit. The lever (1) and ratchet (2) remain in the positions as they moved until the shoe-to-drum clearance becomes even larger.

When the brake pedal is released, the brake shoe is allowed to move back by the amount of clearance "B" by means of the return spring. In this way, the brake shoe-to-drum clearance is automatically adjusted constant every time the brake pedal is depressed.

The brake shoe-to-drum clearance "B" corresponds to 0.6 – 0.8 mm (0.0236 – 0.0315 in.) in terms of the brake drum diameter  $A \leftrightarrow A'$ . And the amount adjusted by one notch of the ratchet corresponds to 0.20 mm (0.008 in.) in terms of the brake drum diameter  $A \leftrightarrow A'$ .

The spring provided in the wheel cylinder prevents the piston from moving back more than the specified brake shoe-to-drum clearance.

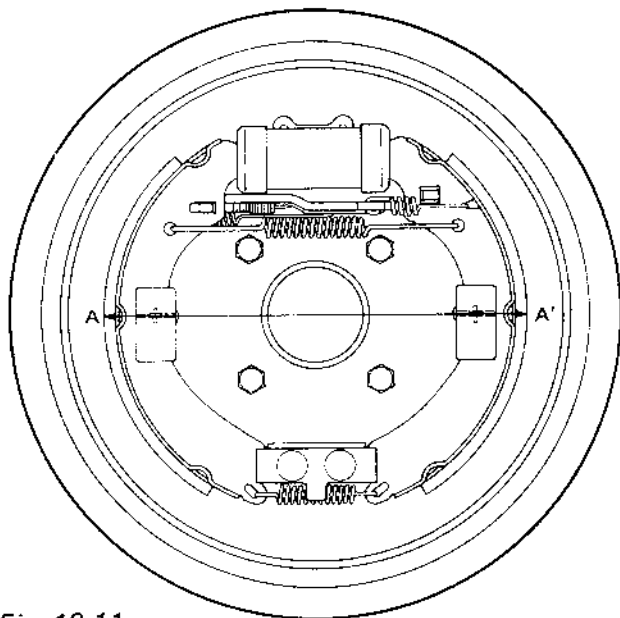


Fig. 19-11

## BOOSTER ASSEMBLY

### [GENERAL DESCRIPTION]

The booster is located between the master cylinder and the brake pedal. It is so designed that the force created when the brake pedal is depressed is mechanically increased combined with the engine vacuum. The booster has a diaphragm of  $\phi$  180 mm effective diameter. Its operation is described in the following pages.

### NOTICE:

- Use all components included in repair kits to service this booster. Lubricate rubber parts, where indicated, with silicone grease provided in kits. The torque values specified are for dry, unlubricated fasteners. If any hydraulic component is removed or brake line disconnected, bleed the brake system.
- Never lubricate any hydraulic component with silicone grease.

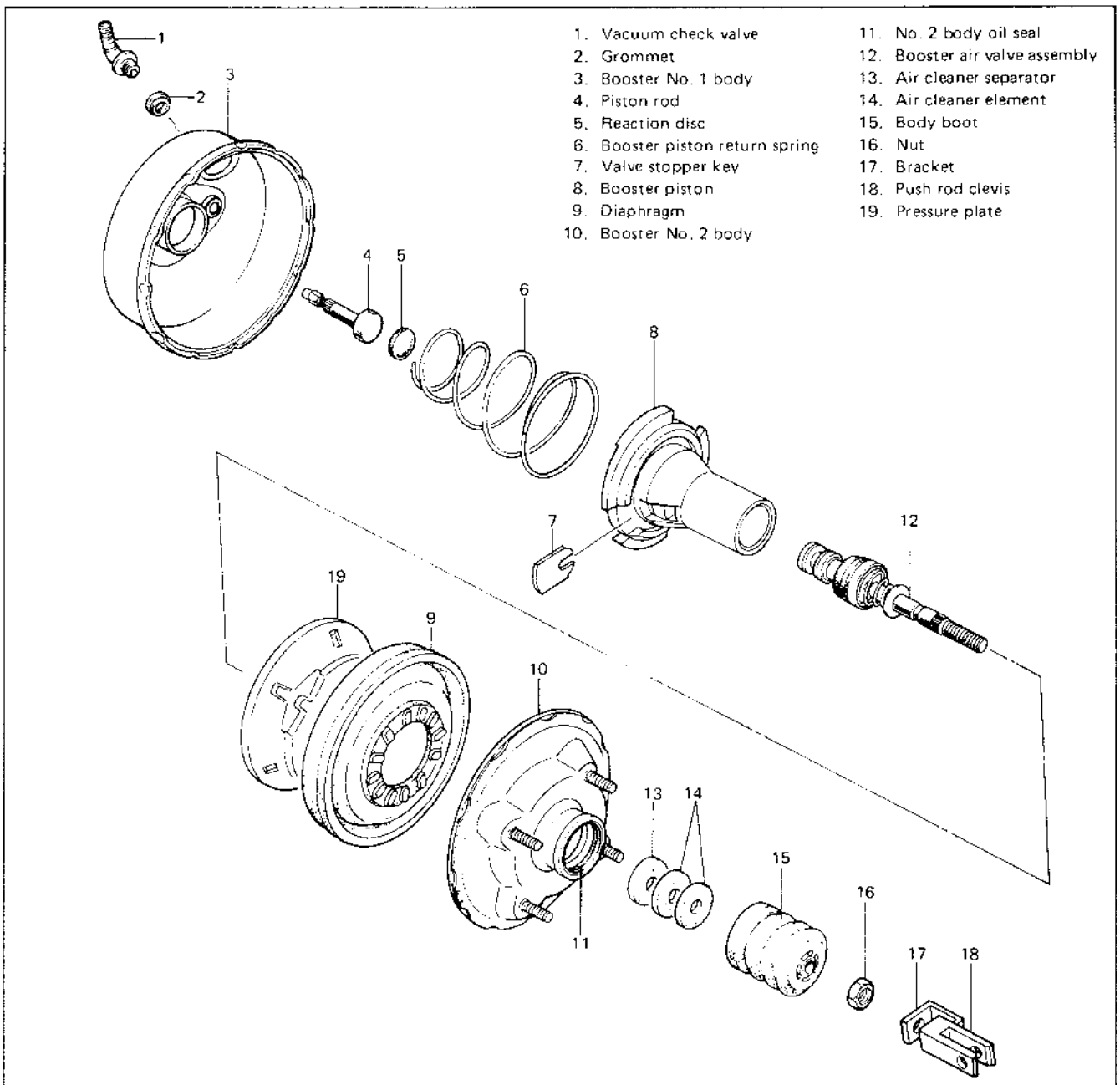
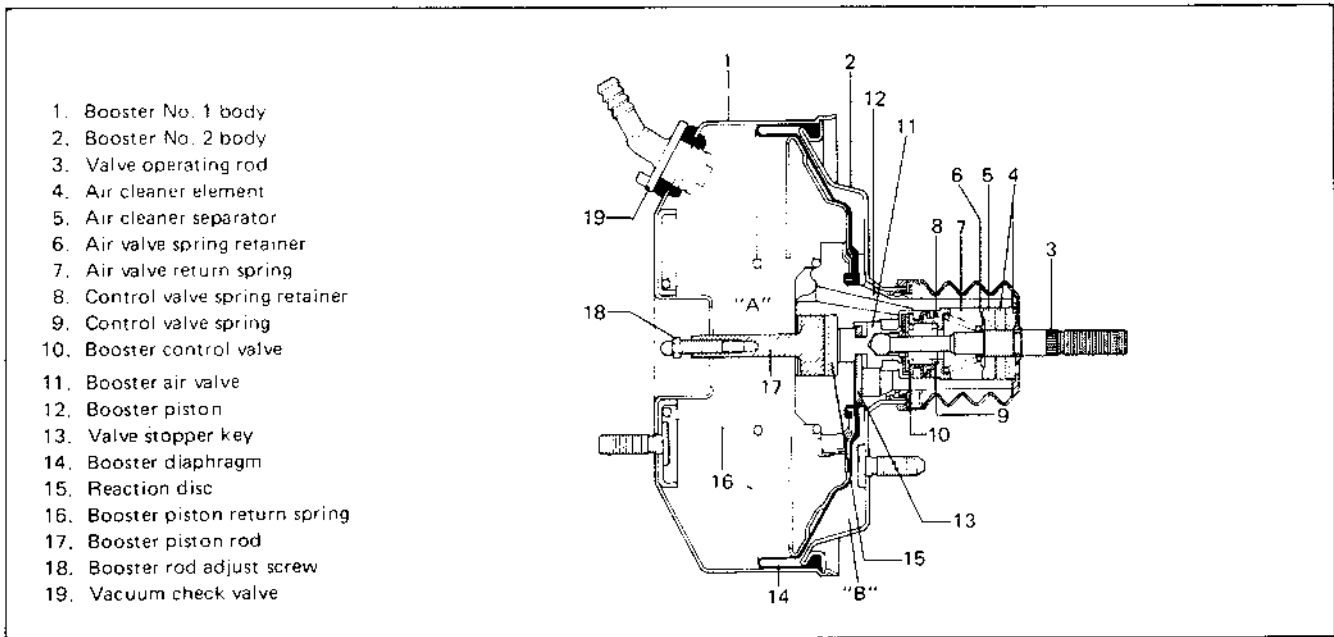


Fig. 19-12

**[Booster OPERATION]**



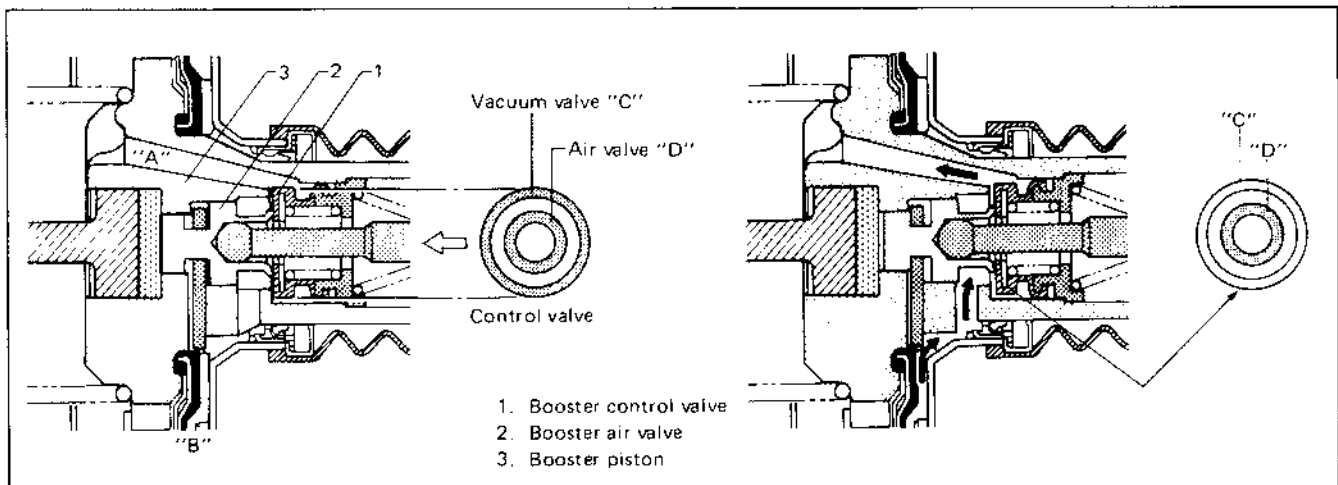
*Fig. 19-13-1 Vacuum Booster Assembly*

When the brake pedal is depressed, the force is transmitted to the piston of the master cylinder through the valve operating rod, booster air valve, reaction disc and piston rod. At the same time, the force of the booster piston developed due to the pressure difference between the two chambers "A" and "B" in the above figure is added to it.

The end of the booster control valve has a double function of a vacuum valve and air valve. That is, as shown in the figure, the booster control valve closes between the "A" and "B" chambers as its outer end "C" contacts the booster piston seat and opens as "C" leaves the booster piston seat (vacuum valve function). Also it closes between the "B" chamber and outside air as its inner end "D" contacts the air valve seat and opens as "D" leaves the air valve seat (air valve function).

**When foot brake pedal is not depressed**

The valve operating rod is pushed to the right by the spring force as shown. The air valve is also enough to the right to contact the valve stopper key as shown. In this state, the vacuum valve (control valve "C") is open and the air valve (control valve "D") is closed. Thus the chambers "A" and "B" conduct and share the same negative pressure (because of no pressure difference) which allows the return spring to push the booster piston to the right.



*Fig. 19-13-2 Vacuum Booster Assembly*



**When foot brake pedal is depressed**

Being pushed by the operating rod, the booster air valve moves to the left as shown. Then the control valve is pushed against the booster piston seat closely by the valve spring force. Thus the vacuum valve (control valve "C") is closed to cut off between the chambers "A" and "B". At this time the air valve (control valve "D") is still closed.

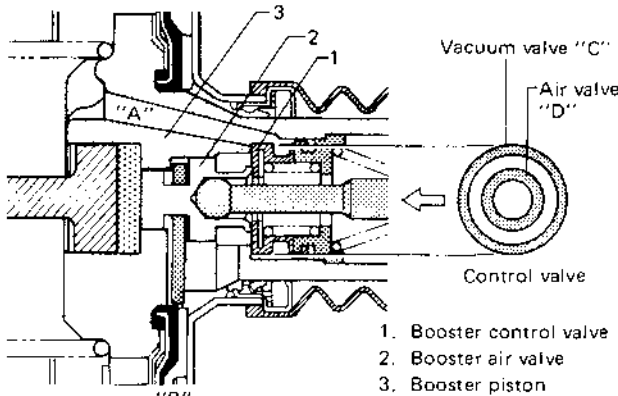


Fig. 19-14-1

As the booster air valve moves further to the left, it leaves the control valve and the air valve (control valve "D") opens to allow the air to flow into the chamber "B". The entry of air causes a difference in pressures between the chambers "A" and "B". When this pressure difference grows greater than the piston return spring force, the booster piston moves to the left and the booster control valve also moves to the left. The resulting air valve (control valve "D") closure stops the air flow into the chamber "B" and its pressure remains as it is. In this way, a small brake pedal depressing force is made into a strong push to the master cylinder push rod to produce high hydraulic pressure.

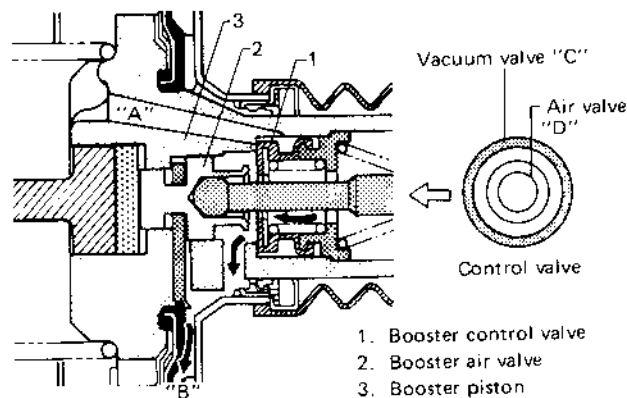


Fig. 19-14-2

**When foot brake pedal is released**

When the brake pedal is released, the booster air valve returns to the right by the master cylinder piston return force and the air valve return spring force as shown. Then the vacuum valve (control valve "C") opens and causes negative pressure in the chamber "B". The result is that the master cylinder piston and booster piston return to their original positions. This is the same state as described under "When foot brake pedal is not depressed".

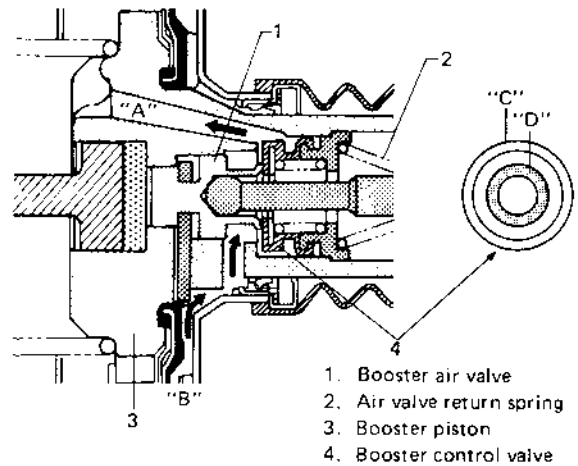


Fig. 19-14-3

**Reference**

Should any of the vacuum related parts in the booster be faulty, the brake force is not increased. Even then, however, the brake depressing force is transmitted to the valve operating rod, booster air valve, valve stopper key and booster piston in that order, to push the master cylinder push rod. Thus, the braking operation itself will not fail.

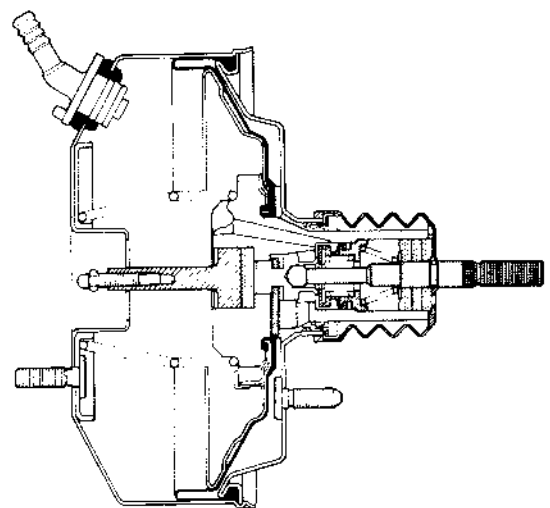


Fig. 19-14-4

## 19-2. FRONT DISC BRAKE

### REMOVAL

- 1) Loosen, but do not remove, front wheel nuts.
- 2) Hoist car.
- 3) Remove wheel nuts and take off front wheels.

### Brake Pad

After taking down the wheel, remove brake pads according to the following procedure.

- 1) Remove caliper antirattle clip.

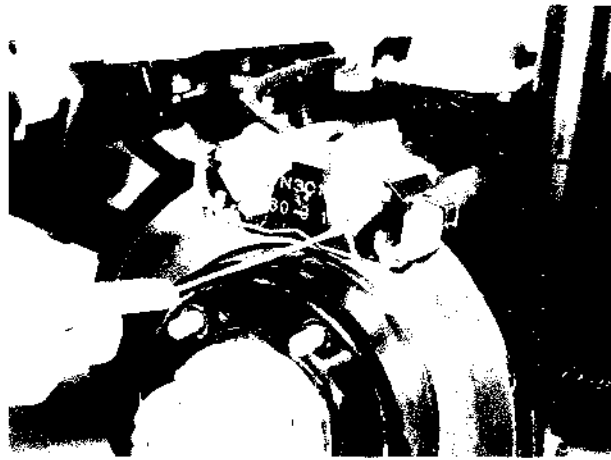


Fig. 19-17

- 2) Remove caliper guide pin caps (2 pcs).
- 3) Remove caliper guide pins (2 pcs) by using 6 mm hexagon wrench.



Fig. 19-18

- 4) Remove pad protector (2 pcs).

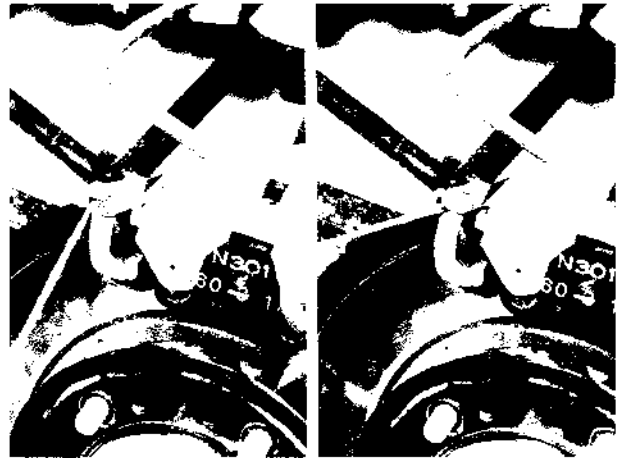


Fig. 19-19

- 5) Remove caliper (cylinder).

### NOTICE:

During removal, be careful not to damage brake flexible hose.

Also, don't depress brake pedal.

- 6) Remove pads.

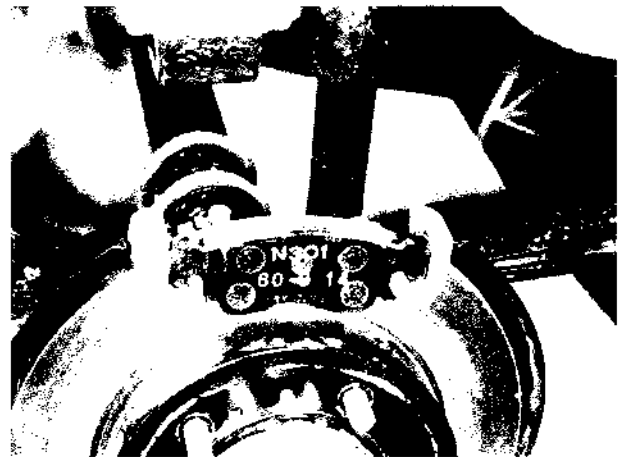


Fig. 19-20

## Caliper

After taking down the wheel, remove piston and piston seal according to the following procedure.

- 1) Clean outside of reservoir.
- 2) Take out fluid with a syringe or such.
- 3) Wipe caliper clean.
- 4) Disconnect brake flexible hose from caliper body (cylinder).

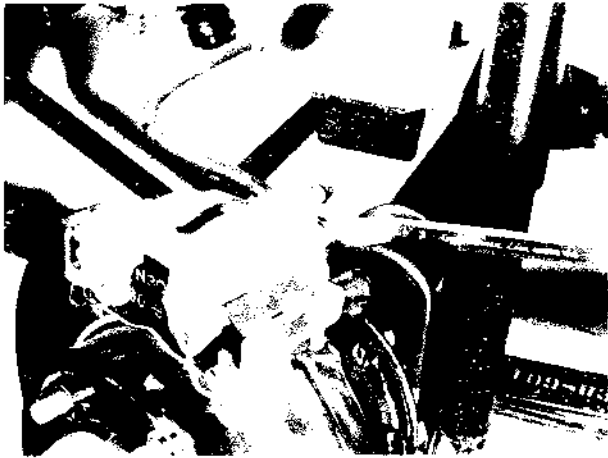


Fig. 19-21

- 5) Remove caliper (cylinder) and bolt. For removal of caliper and pads, refer to steps 1) through 6) of brake pad removal in this section (p. 19-14).

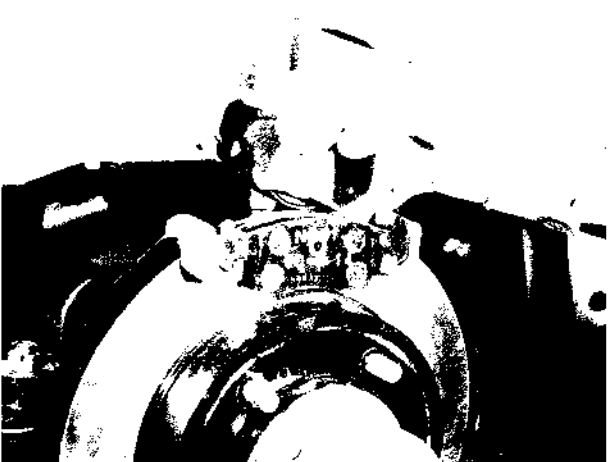


Fig. 19-22

- 6) Blow compressed air into cylinder through bolt hole where flexible hose was fitted. With this air pressure, the piston can be pushed out of cylinder.

### WARNING:

Do not apply too highly compressed air which will cause piston to jump out of cylinder. It should be taken out gradually with moderately compressed air. Do not place your fingers in front of the piston when using compressed air to push it out.

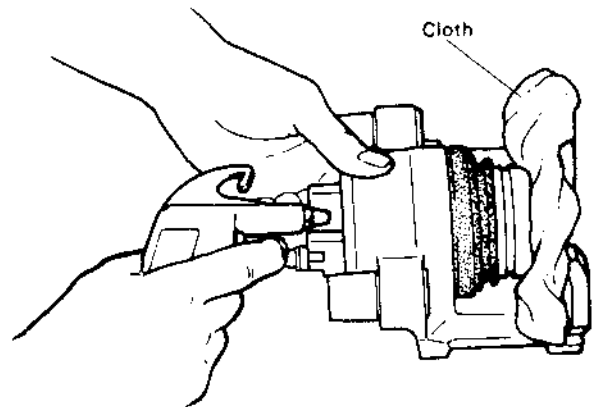


Fig. 19-23

- 7) Remove piston seal using a thin blade like a thickness gauge, etc.

### CAUTION:

Be careful not to damage inside (bore side) of cylinder.

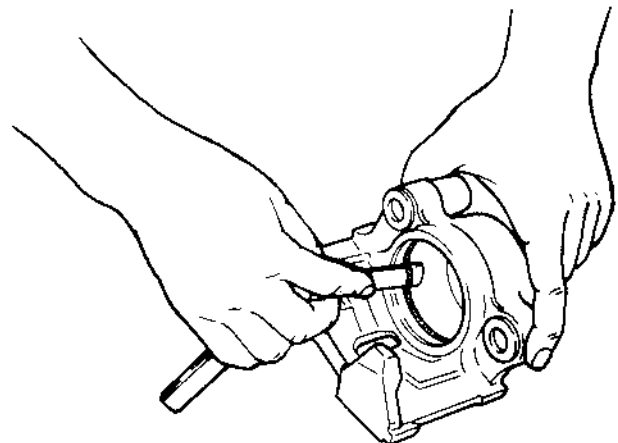


Fig. 19-24

### Disc

1) After taking down the wheel, remove caliper assembly by loosening carrier bolts (2 pcs).

**CAUTION:**

During removal, be careful not to damage brake flexible hose and not to depress brake pedal.



Fig. 19-25

2) Remove disc by using 8 mm bolts (B) (2 pcs).

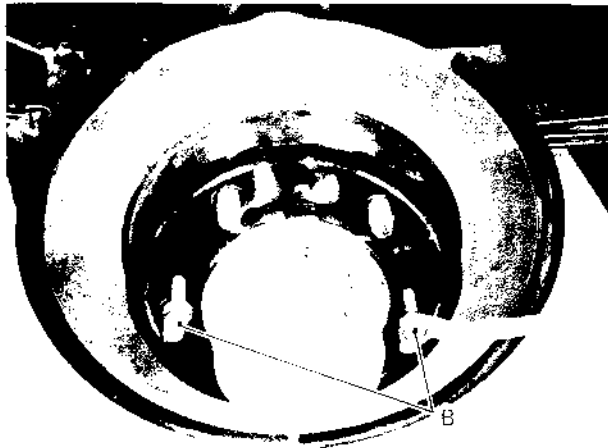


Fig. 19-26

### INSPECTION OF COMPONENTS

#### Brake Pad

Check pad lining for wear. When wear exceeds its limit, replace with a new one.

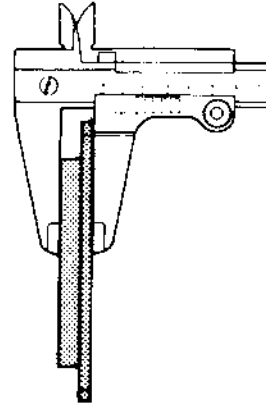


Fig. 19-27

**CAUTION:**

Never polish pad lining with sandpaper. If lining is polished with sandpaper, hard particles of sandpaper will be deposited in lining and may damage disc. When pad lining requires correction, replace it with a new one.

Pad thickness (lining + pad rim)	Standard	Limit
	15.0 mm (0.590 in.)	6.0 mm (0.236 in.)

**NOTICE:**

When pads are removed, visually inspect caliper for brake fluid leak. Correct leaky point, if any.

### Cylinder Slide Bush

Check bush for smooth movement as shown. If it is found faulty, replace guide pin or guide pin sleeve.

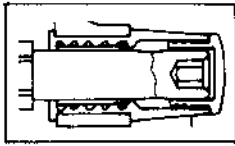


Fig. 19-28

### Bush Dust Boot and Cylinder Boot

Check boots for breakage, crack and damage. If defective, replace.

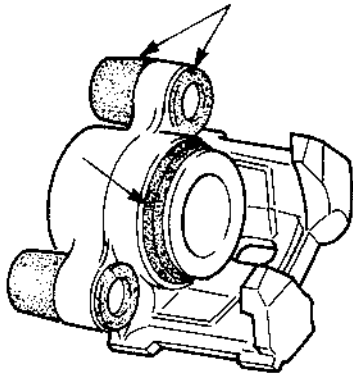


Fig. 19-29

### Piston Seal

Excessive or uneven wear of pad lining may indicate unsmooth return of the piston. In such a case, replace rubber seal.

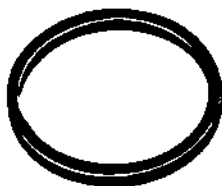


Fig. 19-30

### Brake Disc

Check disc surface for scratches in wearing parts. Scratches on disc surface noticed at the time of specified inspection or replacement are normal and the disc is not defective if these are not serious. But when there are deep scratches or scratches all over the surface, replace disc. When only one side is scratched, polish and correct that side.

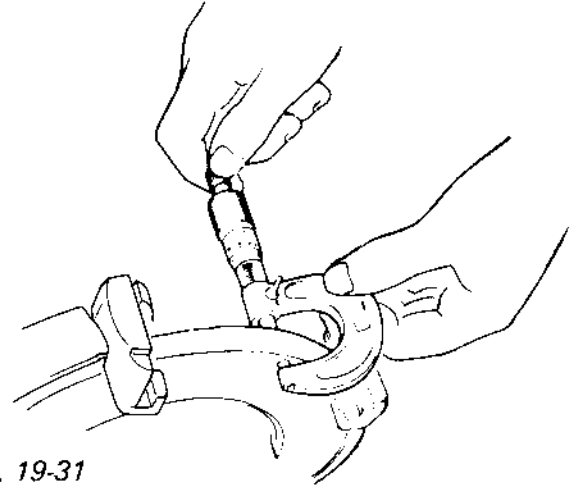


Fig. 19-31

Disc thickness	Standard	Limit
	10 mm (0.394 in.)	8.5 mm (0.334 in.)

To check disc deflection, measure at 2 points on its periphery and center with a dial gauge, while rotating the disc.

Limit on disc deflection	0.15 mm (0.006 in.)
--------------------------	---------------------

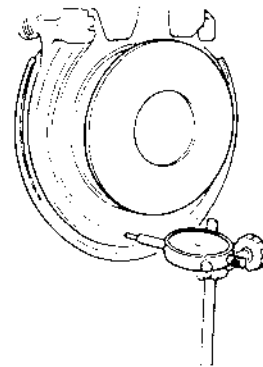


Fig. 19-32

### NOTICE:

Check front wheel bearing for looseness before measurement.

## PRECAUTIONS ON INSTALLATION

Reassemble front brake in the reverse order of disassembly, using care for the following points.

### CAUTION:

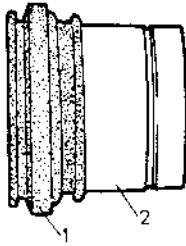
- Wash each part cleanly before installation in the same fluid as the one used in master cylinder reservoir.
- Never use other fluid or thinner.
- Before installing piston and piston seal to cylinder, apply fluid to them.
- After reassembling brake line, bleed air from lines.

### Piston Seal

Piston seal is used to seal piston and cylinder and to adjust clearance between pad and disc. Replace with a new one at every overhaul. Fit piston seal into groove in cylinder taking care not to twist it.

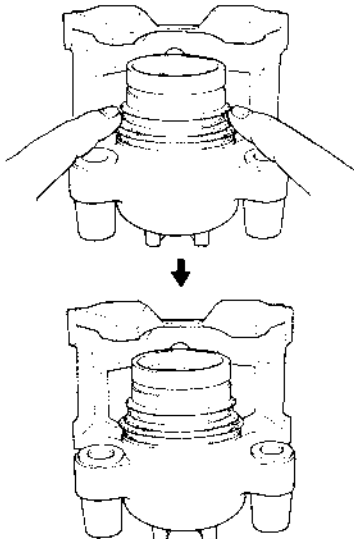
### Piston and Boot

1) Before inserting piston into cylinder, install boot onto piston as shown below.



1. Boot
2. Piston

2) Fit boot as it is in the above figure into boot groove in cylinder with fingers.



Check to make sure that boot is fitted into boot groove in cylinder completely in its circumference.

Fig. 19-33

3) Insert piston into cylinder by hand and fit boot in boot groove in piston.

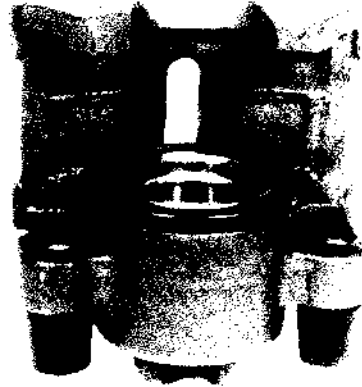


Fig. 19-34

4) To confirm that boot is fitted in its groove in cylinder properly, pull piston out of cylinder a little but do not take it all out.

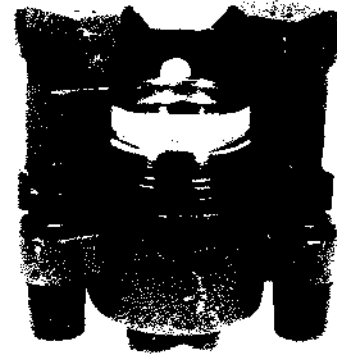


Fig. 19-35

5) Insert piston into cylinder by hand.

### Caliper

Before installing caliper (cylinder body) to carrier, check to ensure that guide pin inserted in each caliper hole can be moved smoothly in thrust direction.



Fig. 19-36

### Front Brake Disc and Pad

- Use care not to scratch or put oil or grease on sliding surface of disc and pad during installation work.
- After installing brake disc to wheel hub properly, tighten wheel nuts to specified torque.

### Front Wheel Spindle

Apply SEALING COMPOUND 366E (99000-31090) to mating surfaces of brake caliper holder and steering knuckle.

### Dust Cover

When fitting dust cover onto brake caliper holder, apply SEALING COMPOUND 366E (99000-31090) to mating surfaces of both parts.

### Front Brake Flexible Hose

- Connect flexible hose to caliper as shown below and tighten hose bolt to specified torque.
- Connect the other end of hose to chassis body bracket, being careful not to kink it with front wheels directed straightforward.

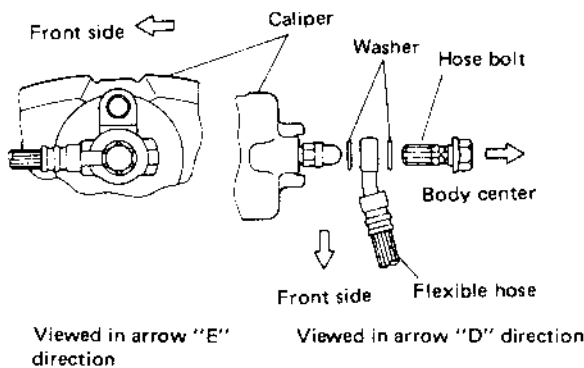


Fig. 19-38

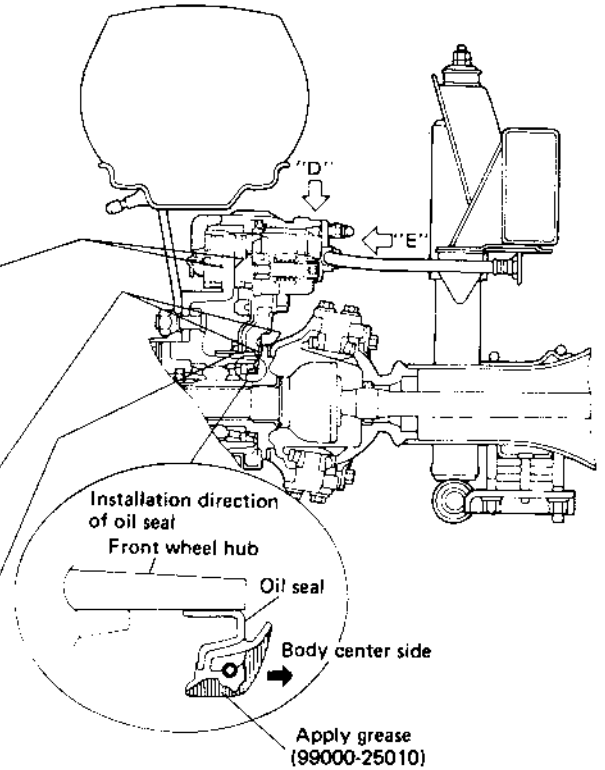


Fig. 19-37

### Tightening torque

Fastening parts	N.m	kg-m (lb-ft)
Flexible hose bolt	20 - 25	2.0 - 2.5 (14.5 - 18.0)
Carrier bolt	70 - 100	7.0 - 10.0 (51.0 - 72.0)
Caliper holder bolt	40 - 60	4.0 - 6.0 (29.0 - 43.0)
Caliper guide pin	25 - 30	2.5 - 3.0 (18.5 - 21.5)
Wheel nut	50 - 80	5.0 - 8.0 (36.5 - 57.5)

### NOTICE:

After completing installation, fill reservoir with brake fluid and bleed brake system. Perform brake test and check each installed part for oil leakage.

### Inspection for Front Brake After Installing

Mount tires and make certain that they rotate smoothly, with a force of less than 3.0 kg (6.6 lb).

#### NOTICE:

For the above check, the following must be observed.

- 1) Jack up front wheels, both right and left, off the ground.
- 2) Set free wheeling hubs of both right and left wheels to "LOCK", if equipped.
- 3) Shift transfer shift lever to 2H (rear wheel) position.
- 4) The below figure shows outer periphery of tire.
- 5) Be careful not to depress brake pedal when checking tire for rotation.

If tire rotation is heavy, check the following:

- Wheel bearings for breakage.
- Wheel bearing starting preload for proper adjustment.
- Disc for flatness (Improper flatness brings disc into contact with lining during rotation and makes rotation heavy).

To check this, measure disc deflection.

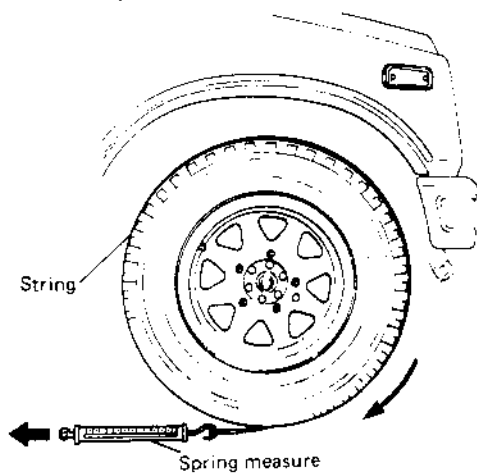


Fig. 19-39

## 19-3. REAR DRUM BRAKE

### REMOVAL

#### Brake Drums

- 1) Remove wheel center cap.
- 2) Loosen, but do not remove, rear wheel nuts and brake drum nuts.
- 3) Hoist car.
- 4) Remove rear wheel nuts and take off rear wheel.
- 5) Check to ensure that parking brake lever is not pulled up.
- 6) To increase clearance between brake shoe and brake drum, remove parking brake shoe lever return spring ① and disconnect parking brake cable joint ③ from parking brake shoe lever ②.

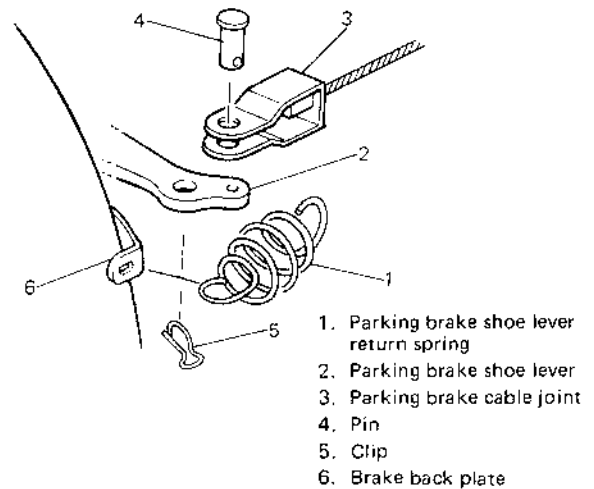


Fig. 19-40

- 7) Remove parking brake shoe lever stopper plate.

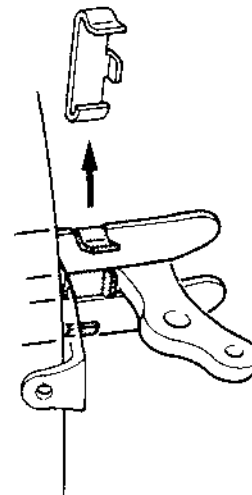


Fig. 19-41



8) Remove brake drum by using special tools.

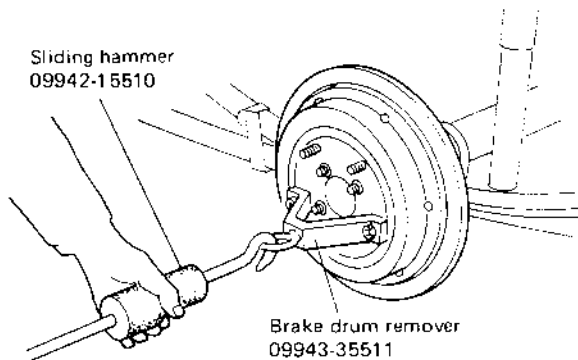


Fig. 19-42

### Brake Shoes and Strut

- 1) Remove brake drum referring to REMOVAL on previous page.
- 2) Remove shoe hold down springs ① by turning shoe hold down pins ② as shown.

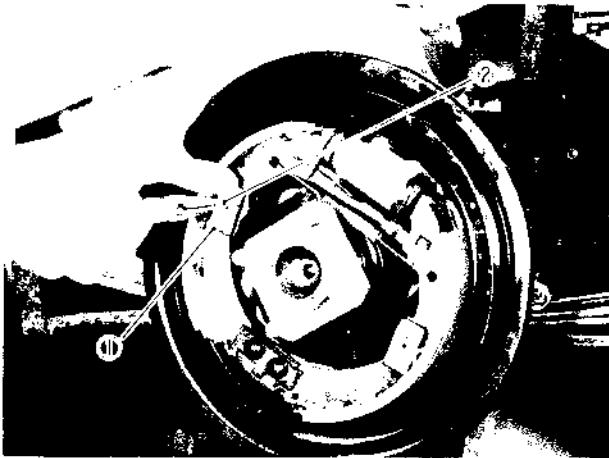


Fig. 19-43

- 3) Remove brake shoes.
- 4) Remove brake shoe strut.

## INSPECTION OF COMPONENTS

### Brake Drum

Inspect drum for cleanliness. Check its braking surface for wear by measuring its inside diameter.

Item	Standard	Service limit
Brake drum ID	220 mm (8.66 in.)	222 mm (8.74 in.)

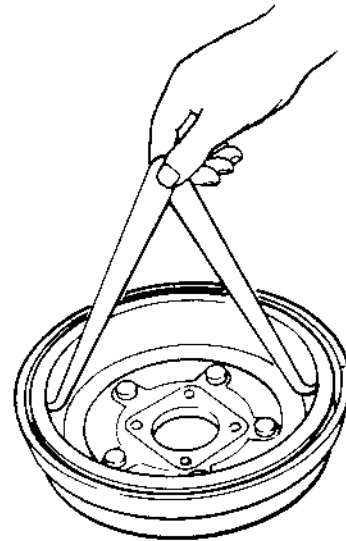


Fig. 19-44

Whenever brake drums are removed, they should be thoroughly cleaned and inspected for cracks, scores, deep grooves.

### Cracked, Scored, or Grooved Drum

A cracked drum is unsafe for further service and must be replaced. Do not attempt to weld a cracked drum. Smooth up any slight scores. Heavy or extensive scoring will cause excessive brake lining wear and it will probably be necessary to resurface drum braking surface.

If brake linings are slightly worn and drum is grooved, drum should be polished with fine emery cloth but should not be cut.

### NOTICE:

When drum is removed, visually inspect wheel cylinder for brake fluid leak. Correct leaky point, if any.

### Brake Shoe and Rim

If lining is worn out beyond service limit, replace shoe.

Brake lining	Standard	Service limit
Thickness (lining + shoe rim)	7.0 mm (0.28 in.)	3.0 mm (0.12 in.)

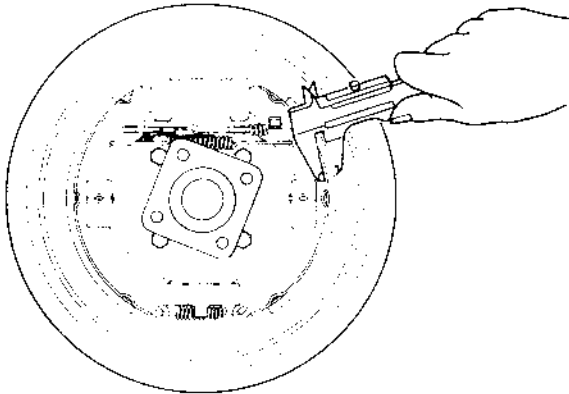


Fig. 19-45

If one of brake linings is worn to or beyond service limit, all linings must be replaced at the same time.

#### NOTICE:

Never polish lining with sandpaper. If lining is polished with sandpaper, hard particles of sandpaper will be deposited in lining and may damage drum. When it is required to correct lining, replace it with a new one.

### Wheel Cylinder

When removing brake drum, check wheel cylinder for oil leakage. If any leakage is found, replace wheel cylinder inner parts.

Inspect wheel cylinder disassembled parts for wear, cracks, corrosion or damage.

#### NOTICE:

Clean wheel cylinder components with brake fluid.

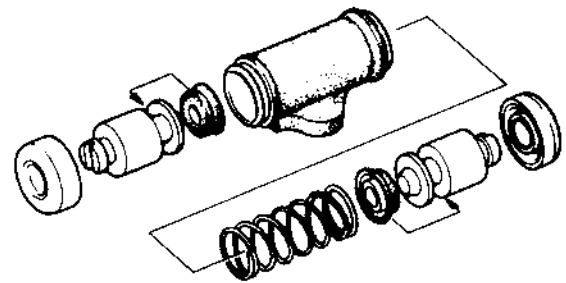


Fig. 19-46

### Brake Strut

Inspect ratchet of strut for wear or damage.



Fig. 19-47

### Springs

Inspect for damage or weakening.  
Inspect each part for rust. If found defective, replace.

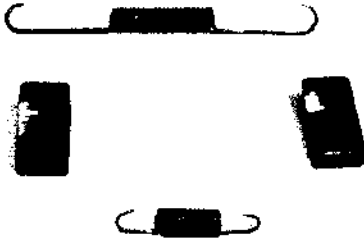
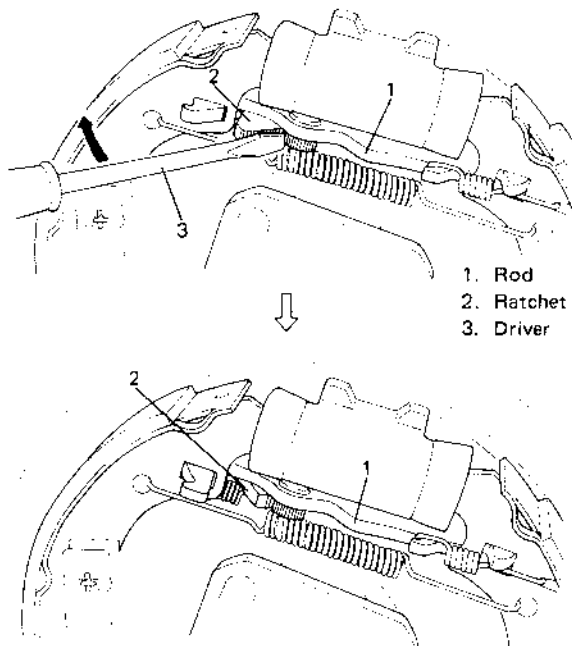


Fig. 19-48

### Self Shoe Clearance Adjusting System

To check self shoe clearance adjusting system of rear brake for operation, follow steps described below.

- 1) Remove brake drum.  
Carry out steps 1) through 8) of brake drum removal (p. 19-20).
- 2) To maximize brake shoe-to-drum clearance, put screw driver between rod and ratchet and push down ratchet as shown in figure.



Above figure shows ratchet position where brake shoe-to-drum clearance is maximum.

Fig. 19-49

- 3) Install parking brake shoe lever stopper plate.

### NOTICE:

Make sure to install this plate.

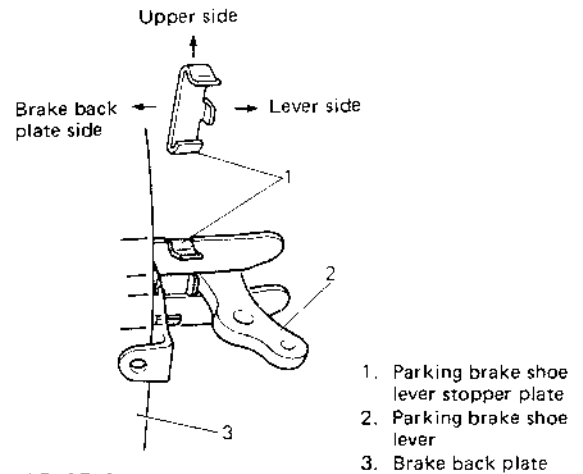


Fig. 19-49-1

- 4) Install brake drum and depress brake pedal with about 30 kg (66 lbs) load 4 or 5 times.

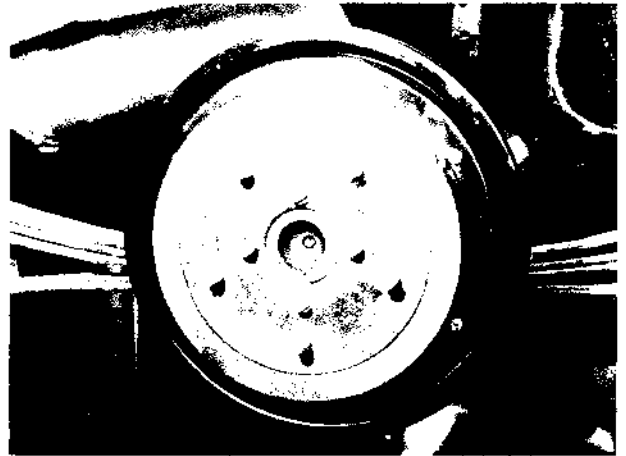


Fig. 19-49-2

- 5) Remove parking brake shoe lever stopper plate.

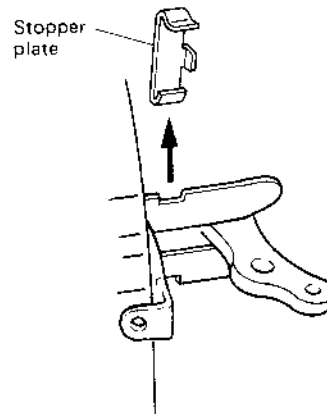
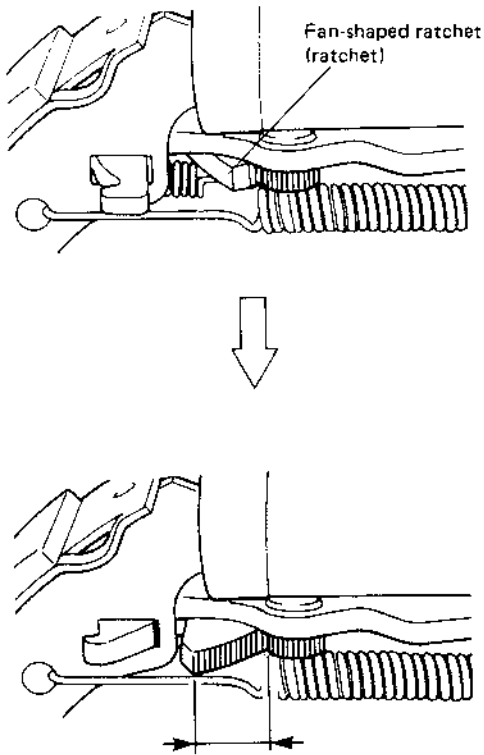


Fig. 19-49-3

6) Remove brake drum and check fan-shaped ratchet position.

If it has shifted off its previous position in step 2) when it was pushed down, it proves proper operation of shoe adjusting system.



If not, replace strut assembly.

Fig. 19-49-4

**NOTICE:**

For brake drum installation, refer to steps 1) through 8) of brake drum installation in this section (p. 19-25).

**PRECAUTIONS ON INSTALLATION**

**Wheel Cylinder**

- 1) Tighten wheel cylinder to brake back plate to specified torque.
- 2) Tighten flare nut of brake pipe to specified torque.
- 3) Install breather plug cap.

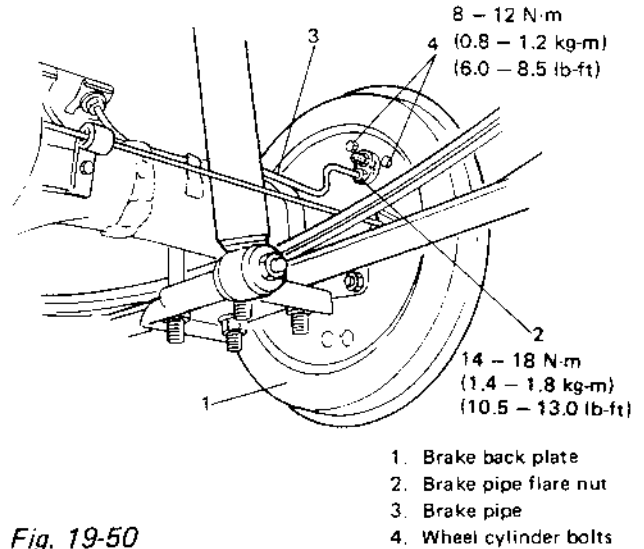


Fig. 19-50

**Brake Shoes**

- 1) Assemble parts as shown in the reverse order of removal.

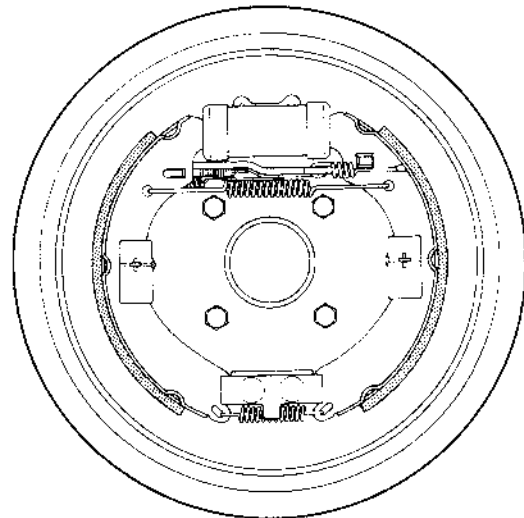


Fig. 19-50-1

**NOTICE:**

When installing shoes, use care not to cause damage to wheel cylinder boots.

2) Install shoe hold down springs by pushing them down in place and turning hold down pins.



Fig. 19-51

### Brake Drum

1) Install parking brake shoe lever stopper plate, referring to the following figure for its installation direction.

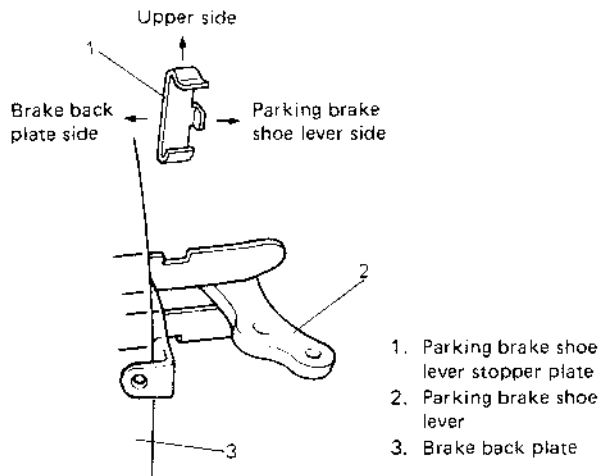


Fig. 19-52

1. Parking brake shoe lever stopper plate

2) Connect brake cable joint to parking brake shoe lever by using joint pin.  
Insert joint pin down from the top and install clip into joint pin hole securely.

### NOTICE:

Check to ensure that clip is in good condition before installing it. If deformed or broken, replace.

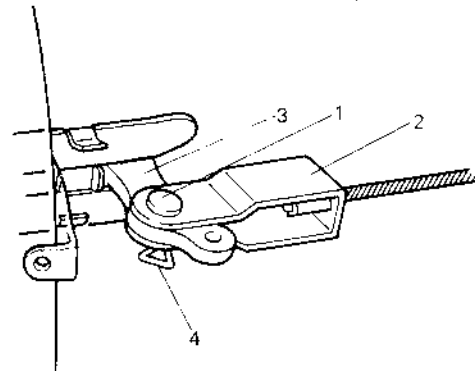
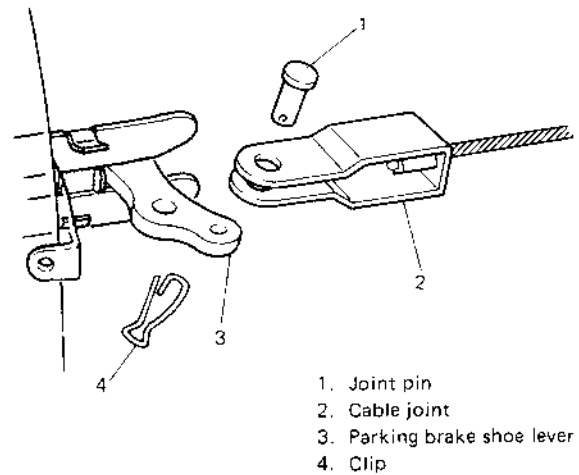


Fig. 19-52-1

3) Install parking brake shoe lever return spring.

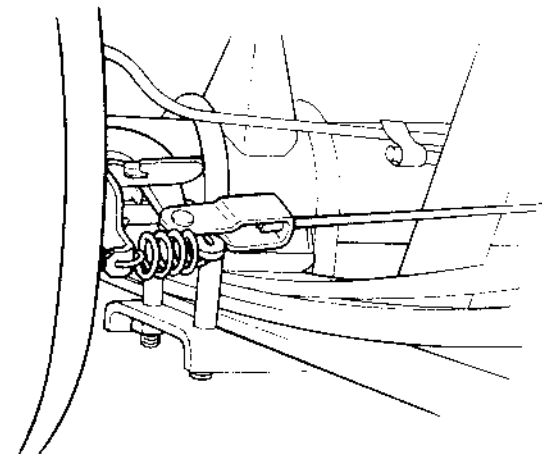


Fig. 19-53

- 4) Before installing brake drum, to maximize brake shoe-to-drum clearance, put screw driver between rod and ratchet and push down ratchet as shown in figure.

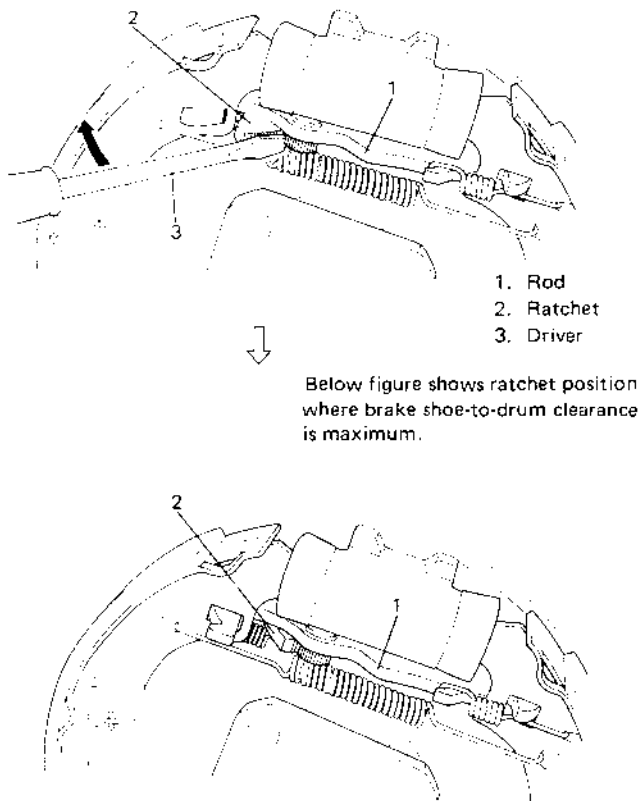


Fig. 19-54

- 5) Install brake drum after making sure that inside of brake drum and brake shoes are free from dirt and oil.
- 6) Torque wheel nuts and brake drum nuts to specification.

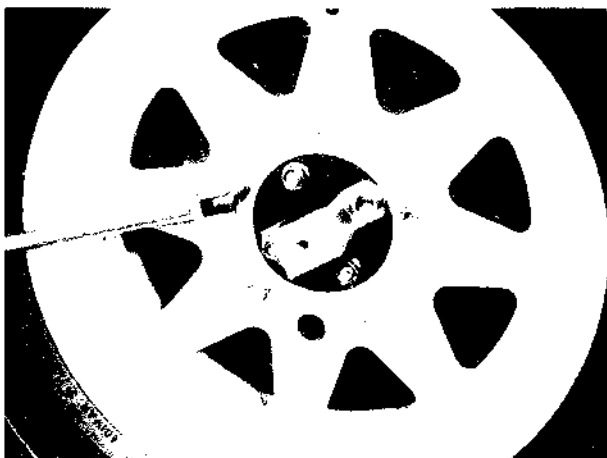


Fig. 19-55

**NOTICE:**

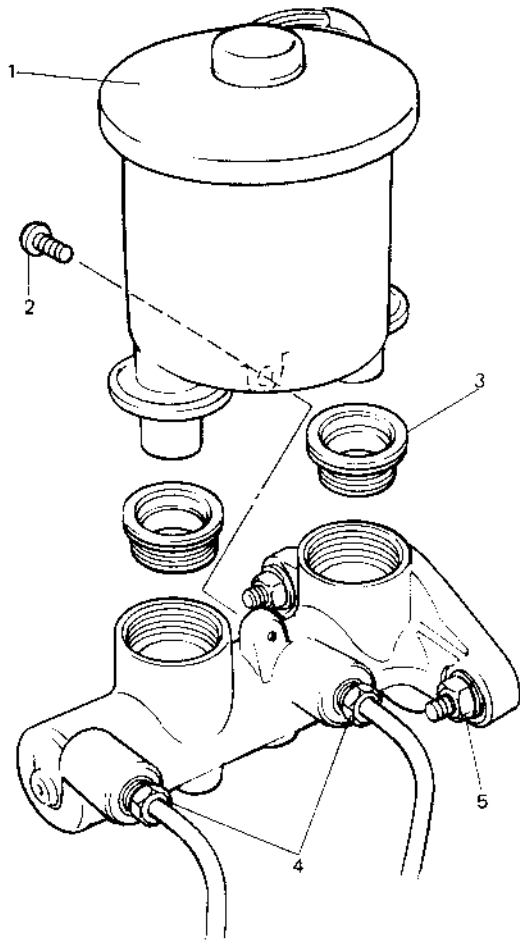
If brake backing plate was removed from wheel cylinder or brake pipe was disconnected from wheel cylinder. Bleed air from brake system. (For bleeding operation, refer to p. 19-46.)

- 7) Upon completion of all jobs, depress brake pedal with about 30 kg (66 lbs) load four or five times so as to obtain proper drum-to-shoe clearance.
- 8) Check to ensure that brake drum is free from dragging and proper braking is obtained. Then remove car from hoist and perform brake test (foot brake and parking brake).

## 19-4. MASTER CYLINDER

### REMOVAL

- 1) Clean outside of reservoir.
- 2) Take out fluid with a syringe or such.
- 3) Remove reservoir connector screw.
- 4) Remove reservoir.



1. Reservoir
2. Connector screw
3. Grommets
4. Flare nuts
5. Attaching nuts

Fig. 19-56

- 5) Disconnect 2 brake pipes from master cylinder.

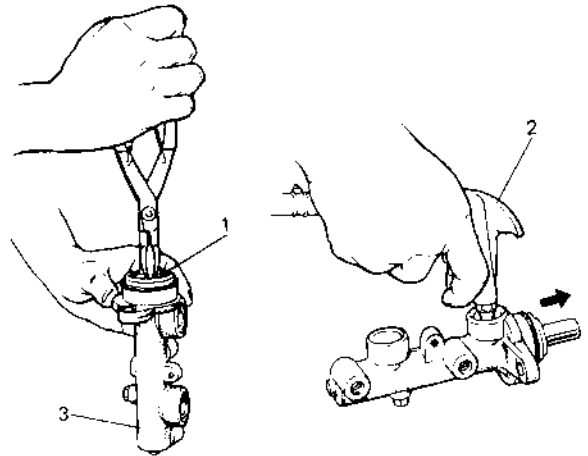
### NOTICE:

Do not allow brake fluid to get on painted surfaces.

- 6) Remove 2 attaching nuts and washers.
- 7) Remove master cylinder.

### DISASSEMBLY

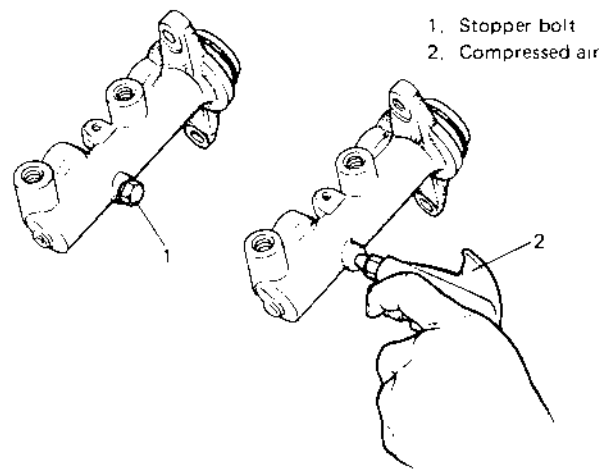
- 1) Remove circlip.
- 2) Remove primary piston by using compressed air as shown. Be cautious during removal as primary piston will jump out.



1. Circlip
2. Compressed air
3. Master cylinder

Fig. 19-57

- 3) Remove piston stopper bolt. Then remove secondary piston by blowing compressed air into hole from which piston stopper bolt was removed.



1. Stopper bolt
2. Compressed air

Fig. 19-58

## INSPECTION OF COMPONENTS

### Master Cylinder Inner Parts

Inspect all disassembled parts for wear or damage, and replace parts if necessary.

#### NOTICE:

- Wash disassembled parts with brake fluid.
- Do not reuse piston cups.

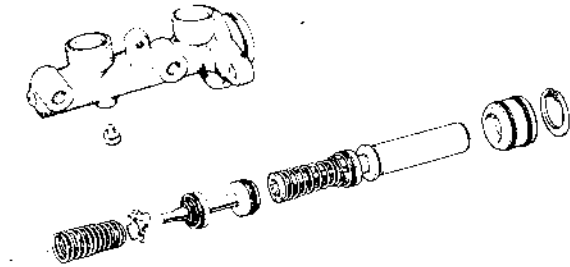


Fig. 19-59

Inspect master cylinder bore for scoring or corrosion. It is best to replace a corroded cylinder. Corrosion can be identified as pits or excessive roughness.

#### NOTICE:

Polishing bore of master cylinder with cast aluminum body with anything abrasive is prohibited, as damage to cylinder bore may occur.

Rinse cylinder in clean brake fluid. Shake excess rinsing fluid from cylinder. Do not use a cloth to dry cylinder, as lint from cloth will remain on cylinder bore surface.

## Reservoir

#### NOTICE:

Do not use shock absorber fluid or any other fluid which contains mineral oil. Do not use a container which has been used for mineral oil or a container which is wet from water. Mineral oil will cause swelling and distortion of rubber parts in the hydraulic brake system and water will mix with brake fluid, lowering the fluid boiling point. Keep all fluid containers capped to prevent contamination.

Fluid to fill reservoir with is indicated on reservoir cap of the car with embossed letters or in owner's manual supplied with the car. Add fluid up to MAX line.

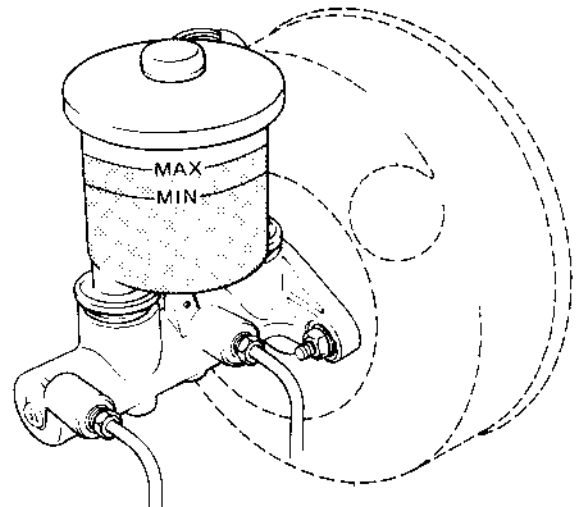


Fig. 19-60



## ASSEMBLY

### NOTICE:

Before assembling, wash each part in fluid recommended to use for the car.

1) Assemble secondary piston as shown below.

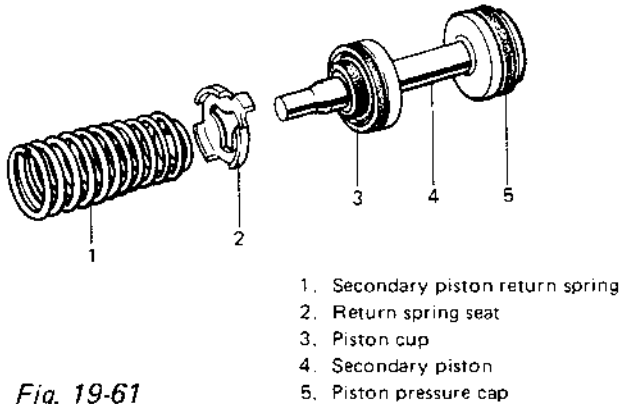


Fig. 19-61

2) Install secondary piston assembly into cylinder.

3) Install primary piston in cylinder.

4) Depress, and install circlip.

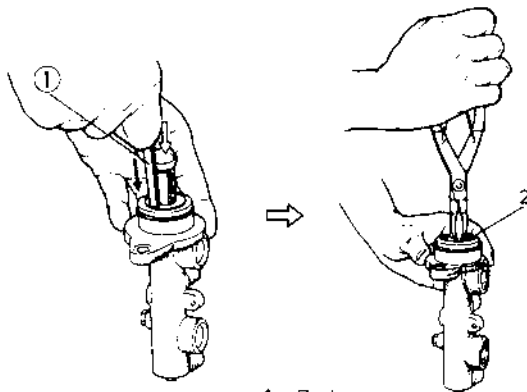


Fig. 19-62

5) Install piston stopper bolt with pistons pushed in all the way and tighten it to specified torque.

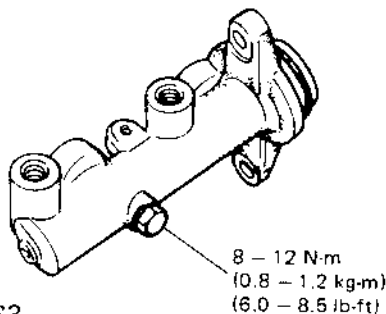


Fig. 19-63

6) For installation on car, refer to INSTALLATION.

## PRECAUTION OF INSTALLATION

### NOTICE:

- See NOTICE at the beginning of this section.
- Adjust clearance between booster piston rod and primary piston with special tool (See page 19-33).

1) Install master cylinder as shown and torque attaching nuts to specification.

2) Connect 2 hydraulic lines and torque flare nuts to specification.

3) When using new grommets, lubricate them with the same fluid as the one to fill reservoir with. Then press-fit grommets to master cylinder. Grommets must be seated in place.

4) Install reservoir and tighten screw to specified torque.

5) Fill reservoir with specified fluid.

After installing, check brake pedal height, bleed air from system (See p. 19-43 and p. 19-46) and also check for fluid leakage.

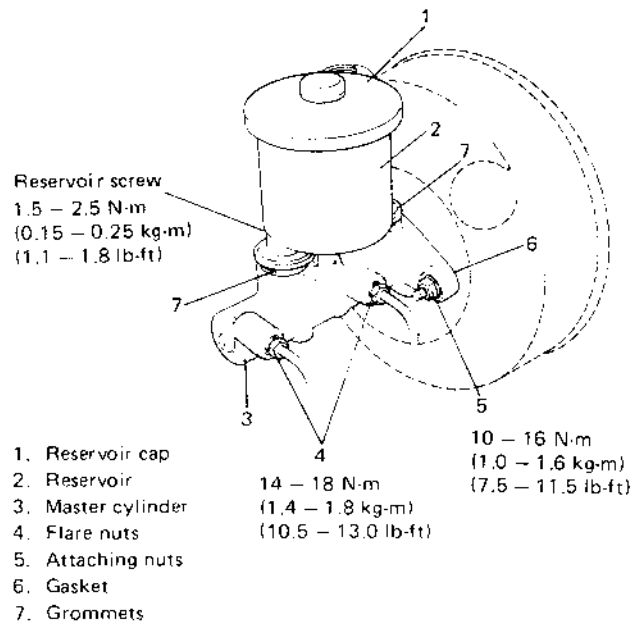
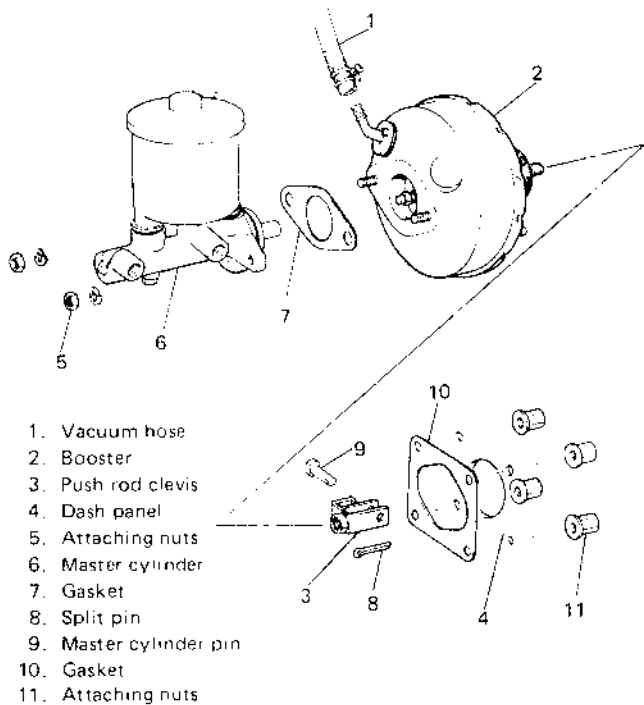


Fig. 19-64

## 19-5. BRAKE BOOSTER

### REMOVAL

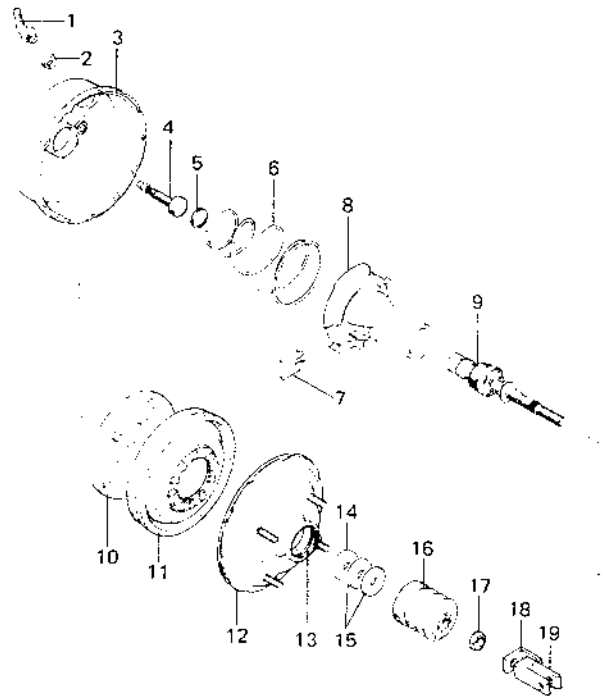
- 1) Take out fluid from master cylinder with a syringe or such.
- 2) Disconnect 2 brake pipes from master cylinder and remove master cylinder from booster.
- 3) Disconnect vacuum hose from booster.
- 4) Disconnect push rod clevis from brake pedal arm.
- 5) Remove attaching nuts and then booster as shown.



1. Vacuum hose
2. Booster
3. Push rod clevis
4. Dash panel
5. Attaching nuts
6. Master cylinder
7. Gasket
8. Split pin
9. Master cylinder pin
10. Gasket
11. Attaching nuts

Fig. 19-65

### DISASSEMBLY



- |                                 |                           |
|---------------------------------|---------------------------|
| 1. Vacuum check valve           | 11. Diaphragm             |
| 2. Grommet                      | 12. Booster No. 2 body    |
| 3. Booster No. 1 body           | 13. No. 2 body oil seal   |
| 4. Piston rod                   | 14. Air cleaner separator |
| 5. Reaction disc                | 15. Air cleaner element   |
| 6. Booster piston return spring | 16. Body boot             |
| 7. Valve stopper key            | 17. Nut                   |
| 8. Booster piston               | 18. Bracket               |
| 9. Booster air valve assembly   | 19. Push rod clevis       |
| 10. Pressure plate              |                           |

Fig. 19-66

- 1) Remove piston rod from booster.
- 2) Remove push rod clevis and nut.

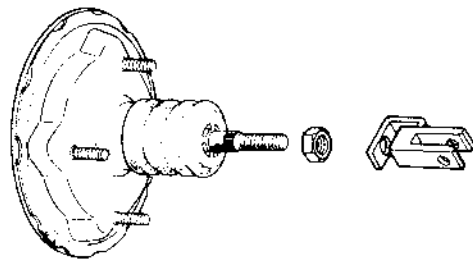


Fig. 19-67

3) Set booster to special tool (A) as shown.

**NOTICE:**

When setting, check to be sure that booster vacuum check valve is not in faulty contact with base of special tool.

Tighten 2 nuts on upper part of special tool evenly to specified torque.

Special tool nuts tightening torque	N·m	kg·m	lb·ft
	3 – 5	0.3 – 0.5	2.2 – 3.6

**NOTICE:**

Be careful not to over-tighten nuts, or booster body will be deformed.

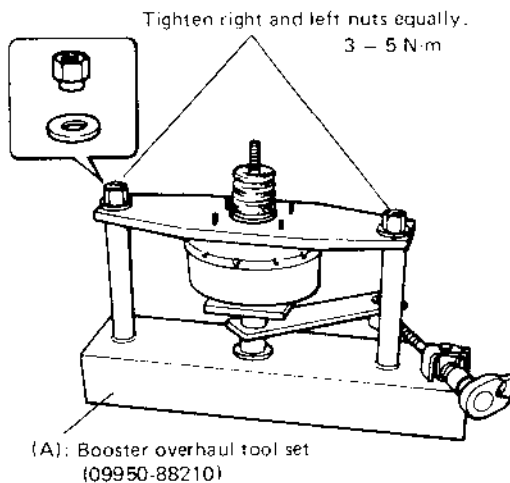


Fig. 19-68

4) Turn special tool bolt clockwise until No. 1 body projecting part and No. 2 body depressed part fit each other.

Once they are matched, make match marking on No. 1 and No. 2 bodies to facilitate their installation.

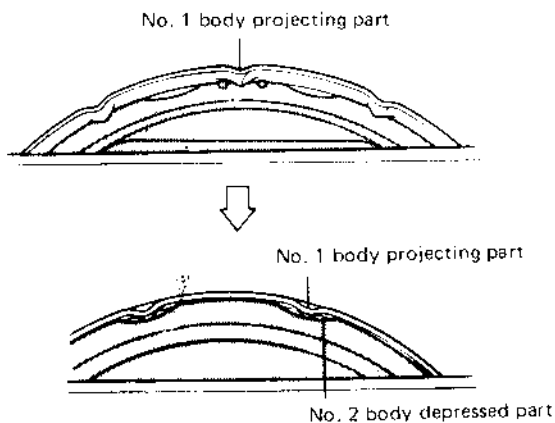


Fig. 19-69

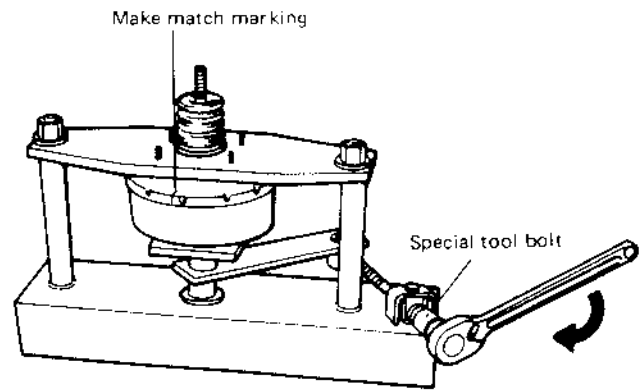


Fig. 19-70

5) Remove booster from special tool and separate No. 1 body and No. 2 body. Remove piston return spring.

**NOTICE:**

When separating two bodies, hold both bodies carefully to prevent either body from jumping off by spring force.

6) From booster No. 2 body, remove boot, air cleaner elements and air cleaner separator in this order.

7) Using camshaft pulley holder (special tool 09917-68210), turn booster piston counter-clockwise and remove piston.

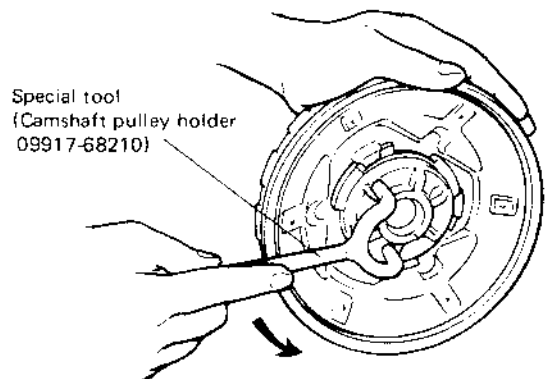
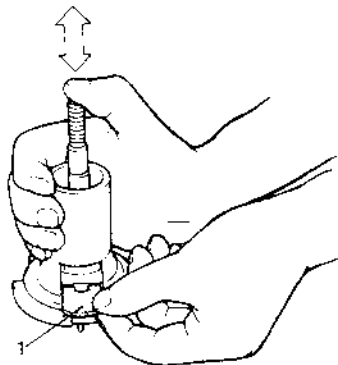


Fig. 19-71

8) While compressing air valve spring (by moving rod up and down as shown), remove valve stopper key. Then remove booster air valve assembly from booster piston.

**NOTICE:**

Booster air valve assembly can't be disassembled.



1. Valve stopper key

Booster air valve assembly

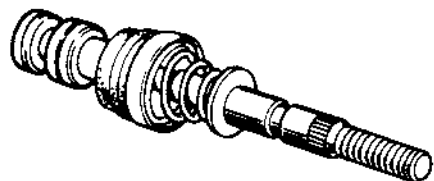


Fig. 19-72

9) Remove diaphragm from pressure plate.

**NOTICE:**

Don't use screwdriver or any other tool for removal. Pull it off by hand carefully handling pressure plate groove area where diaphragm is fitted.

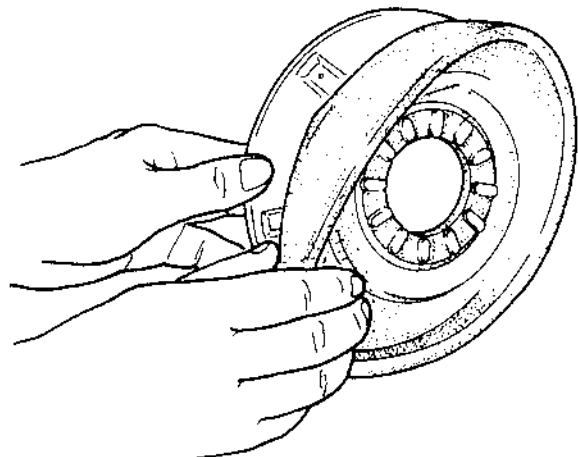


Fig. 19-73

10) Remove reaction disc from booster piston with fingers.

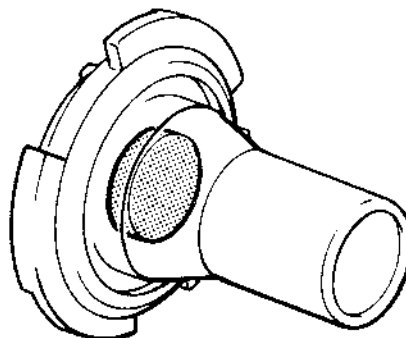
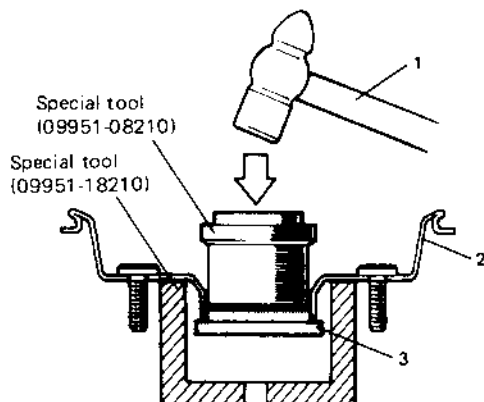


Fig. 19-74

11) Remove oil seal from booster No. 2 body with special tools as shown.

**NOTICE:**

Removed oil seal must not be reused.



- 1. Hammer lightly
- 2. No. 2 body
- 3. Oil seal

Fig. 19-75

## INSPECTION

### Inner Parts

#### NOTICE:

After disassembly, soak all metal parts in ethyl alcohol. Wipe rubber diaphragm and plastic parts with a clean cloth. Use ethyl alcohol damped cloth to wipe out heavy dirt. Application of much ethyl alcohol especially to rubber parts is prohibited.

#### [Rubber parts]

Wipe fluid from rubber parts and carefully inspect each rubber part for cuts, nicks or other damage. These parts are the key to the control of air flow. If there is any question as to the serviceability of rubber parts, REPLACE them.

#### [Metal parts]

BADLY DAMAGED ITEMS, OR THOSE WHICH WOULD TAKE EXTENSIVE WORK OR TIME TO REPAIR, SHOULD BE REPLACED. IN CASE OF DOUBT, INSTALL NEW PARTS.

### Inspection/Adjustment of Clearance Between Booster Piston Rod and Master Cylinder Piston

The length of booster piston rod is adjusted to provide specified clearance between piston rod end and master cylinder piston.

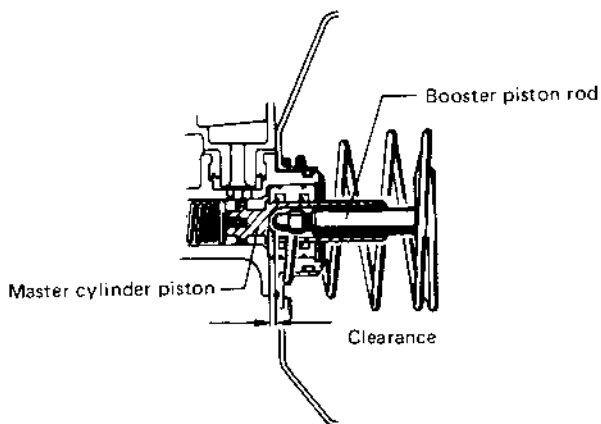


Fig. 19-76

- Before measuring clearance, push piston rod several times so as to make sure reaction disc is in place.
- Take measurement with gasket installed to master cylinder.
- Keep inside of booster at atmospheric pressure for measurement.

1) Set special tool (D) on master cylinder and push pin until it contacts piston.

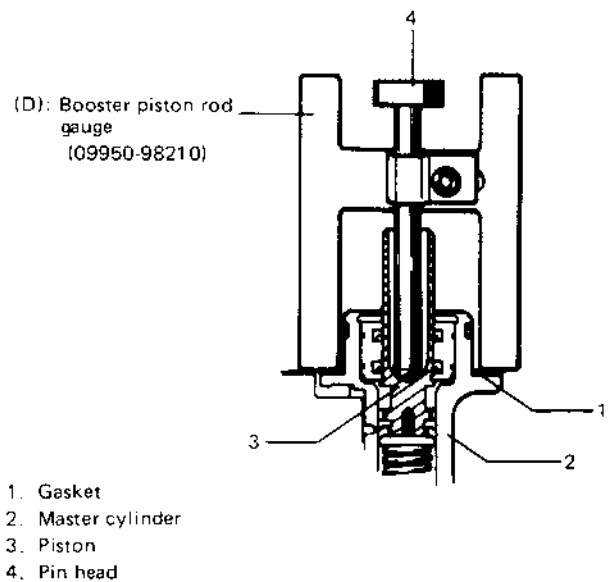


Fig. 19-77

- 2) Turn special tool upside down and place it on booster. Adjust booster piston rod length until rod end contacts pin head.
- 3) Adjust clearance by turning adjusting bolt of piston rod.

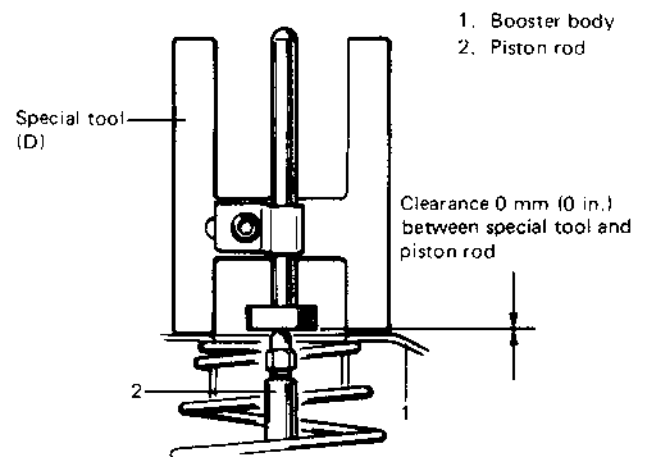


Fig. 19-78

#### Reference

When adjusted as above, if negative pressure is applied to booster with engine at idle, piston to piston rod clearance should become 0.1 – 0.5 mm (0.004 – 0.020 in.).

## BOOSTER INSPECTION TABLE

Part	Inspect For	Corrective Action
1. Booster piston	Cracks, distortion or damage.	Replace.
2. Air valve ass'y (Control valve spring)	Damaged or worn seal surfaces.	Replace.
3. Reaction disc	Damage or wear.	Replace.
4. Diaphragm and boot	Damage.	Replace.
5. Piston rod	Damage or bend.	Replace.
6. Booster No. 1 & No. 2 body.	<ol style="list-style-type: none"> <li>1. Scratches, scores, pits, dents, or other damage affecting rolling or sealing of diaphragm or other seals.</li> <li>2. Cracks, damage at ears, damaged threads on studs.</li> <li>3. Bent or nicked locking lugs.</li> <li>4. Loose studs.</li> </ol>	<p>Replace, unless easily repaired.</p> <p>Replace, unless easily repaired.</p> <p>Replace, unless easily repaired.</p> <p>Replace.</p>
7. Air filters and separator	Dirt.	Replace.

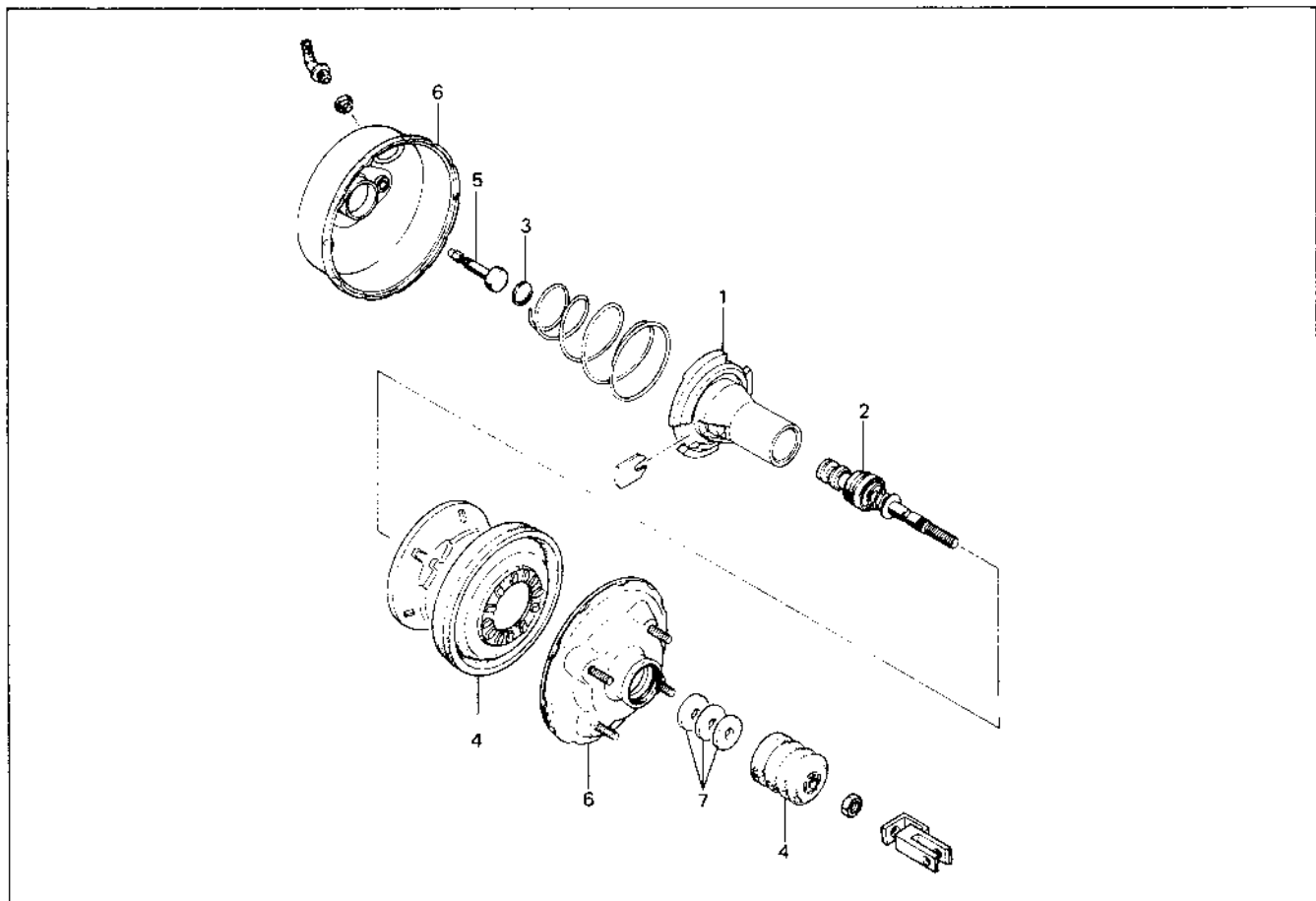


Fig. 19-79

## ASSEMBLY

### NOTICE:

- See NOTICE at the beginning of this section.
- Be sure to use silicon grease wherever application of grease is instructed during assembly. Use of oil and grease for installation of check valve and its grommet is strictly prohibited.

- 1) Apply grease to oil seal outer surface and oil seal lip as shown. Press-fit oil seal to booster No. 2 body by using special tool (B) and (C).

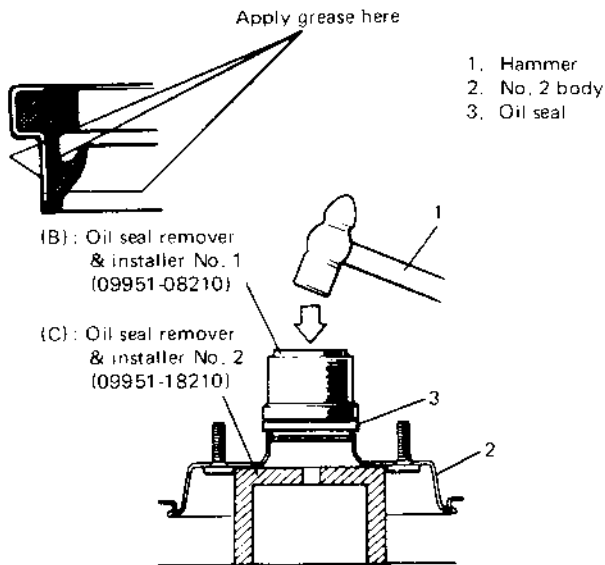


Fig. 19-80

- 2) Install booster air valve assembly to booster piston. Before installation, apply grease as shown.

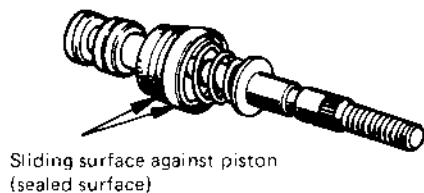


Fig. 19-81

- 3) Compress air valve assembly and insert valve stopper key.

### NOTICE:

Be sure that valve assembly is in piston "A" as indicated in figure. (Don't force installation.)

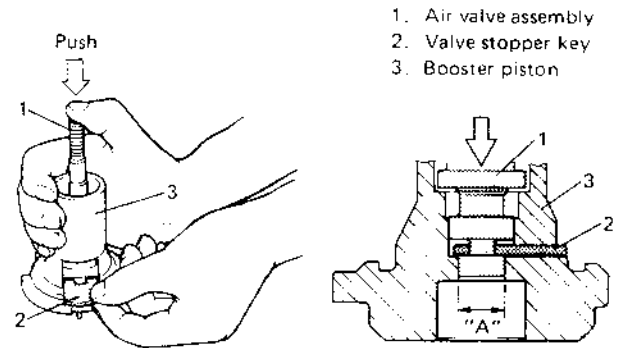


Fig. 19-82

- 4) Install diaphragm to pressure plate by hand.

### NOTICE:

Check to be sure that diaphragm is seated securely in pressure plate groove for diaphragm by turning diaphragm.

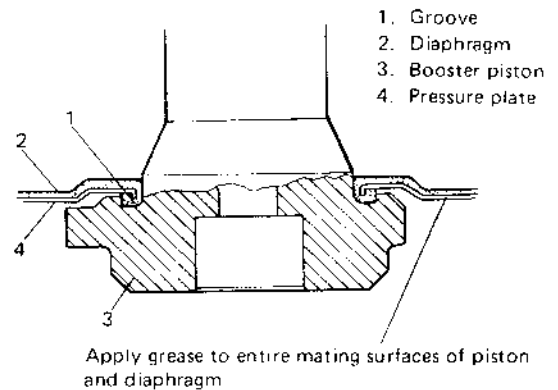


Fig. 19-83

- 5) Install reaction disc to booster piston after greasing its entire face.
- 6) Install booster piston to booster No. 2 body.

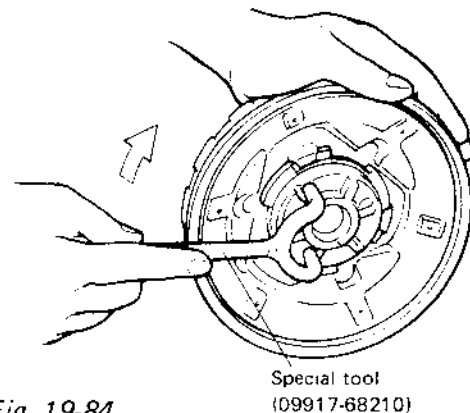
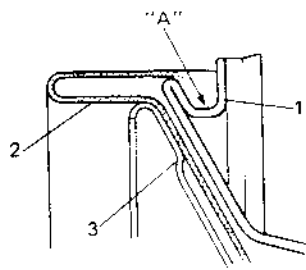


Fig. 19-84

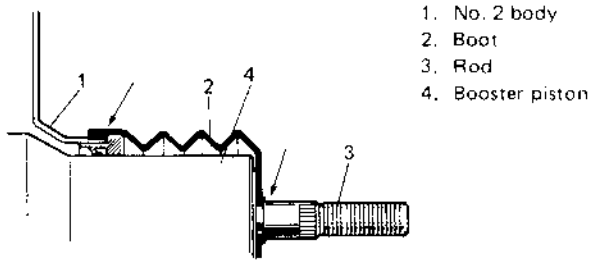


1. Booster No. 2 body
2. Diaphragm
3. Pressure plate

Check all around booster No. 2 body to make sure that diaphragm is seated securely in its outer groove as shown in "A".

Fig. 19-85

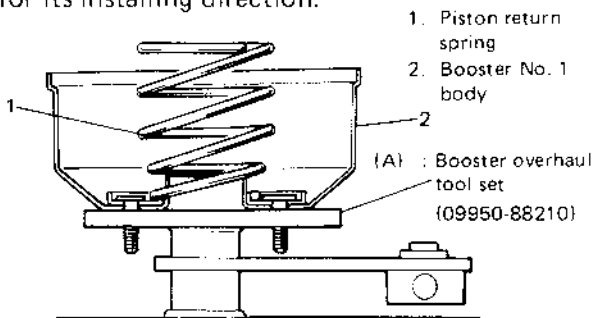
- 7) Install air cleaner separator and then 2 elements to rod of air valve assembly.
- 8) Install body boot to booster No. 2 body. Both ends of boot must be fitted securely as shown.



1. No. 2 body
2. Boot
3. Rod
4. Booster piston

Fig. 19-86

- 9) Place No. 1 body on special tool (A). Then install piston return spring, being careful for its installing direction.

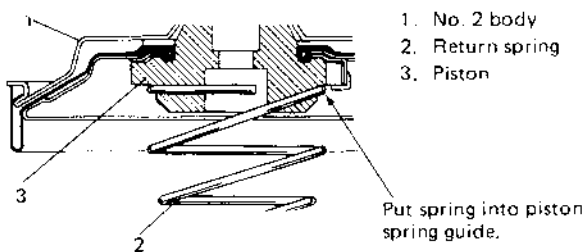


1. Piston return spring
2. Booster No. 1 body

(A) : Booster overhaul tool set (09950-88210)

Fig. 19-87

- 10) Place booster No. 2 body on piston return spring. Then check to be sure that spring is in piston spring guide.



1. No. 2 body
2. Return spring
3. Piston

Put spring into piston spring guide.

Fig. 19-88

- 11) Put No. 1 and No. 2 bodies together by aligning markings made before disassembly. Holding No. 2 body with upper plate (special tool) as shown, torque 2 nuts equally to specification.

Special tool nuts tightening torque	N-m	kg-m	lb-ft
	3 - 5	0.3 - 0.5	2.2 - 3.6

**NOTICE:**

When holding No. 2 body, use care so that diaphragm is not caught by projections at 16 locations around No. 1 body.

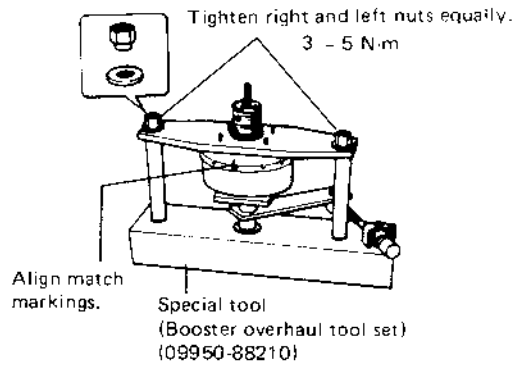


Fig. 19-89

- 12) Turn special tool bolt counterclockwise until No. 1 body projecting part comes to mid-position of No. 2 body depressed parts as shown.

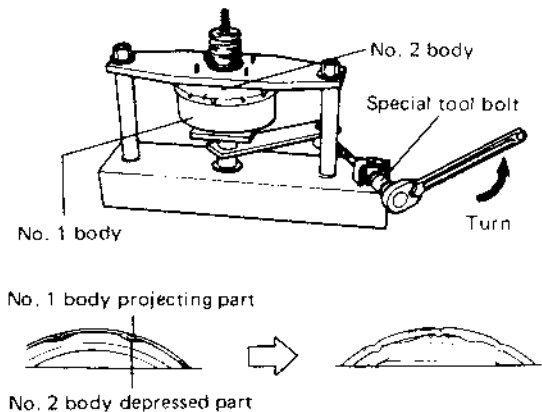


Fig. 19-90



- 13) Remove booster from special tool and install push rod clevis so that below measurement "A" is obtained and torque nut to specification.

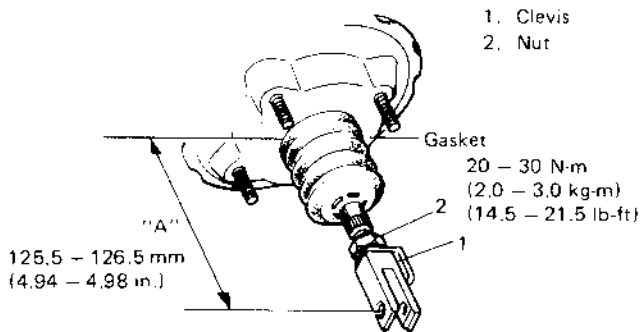


Fig. 19-91

- 14) Insert piston rod into booster piston.

**NOTICE:**

Whenever booster was disassembled, make sure to check clearance between piston rod and master cylinder piston after reassembly. (For details, refer to p. 19-33.)

**INSTALLATION**

**NOTICE:**

- See **NOTICE** at the beginning of this section.
- Adjust clearance between booster piston rod and master cylinder piston with special tool. (See page 19-33.)
- Check length of push rod clevis. (Refer to Fig. 19-91).

- 1) Install booster to dash panel as shown. Then connect booster push rod clevis to pedal arm with pin and split pin.
- 2) Torque booster attaching nuts to specification.
- 3) Install master cylinder to booster and torque attaching nuts to specification.
- 4) Connect 2 brake pipes and torque flare nuts to specification. (See p. 19-29).
- 5) Fill reservoir with specified fluid.
- 6) Bleed air from brake system. (See **BLEEDING BRAKES** on p. 19-46).
- 7) After installing, check pedal height and play. (See p. 19-43).

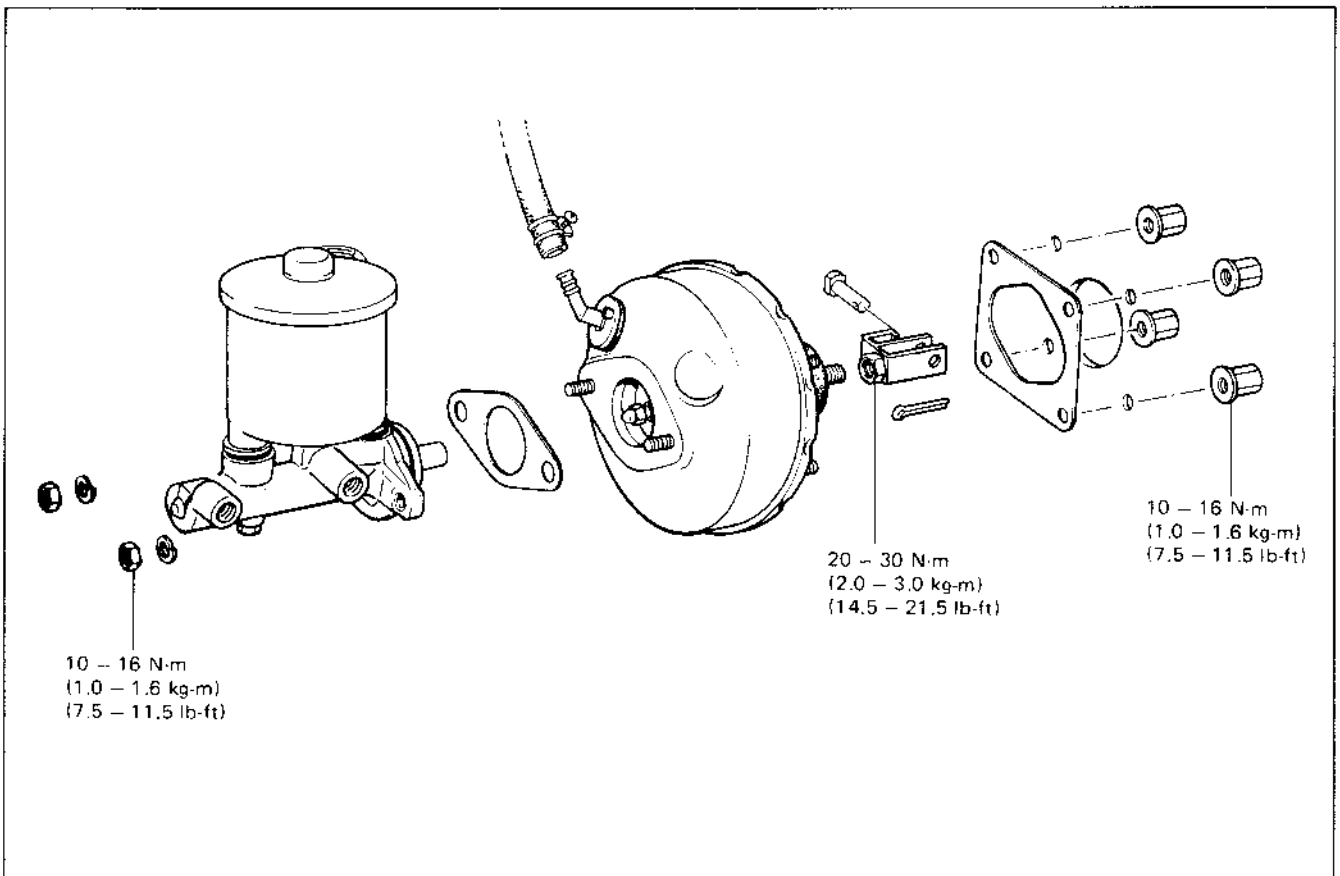


Fig. 19-92

## 19-6. PARKING BRAKE

### NOTICE:

For parking brake inspection and adjustment, refer to p. 19-44 under 19-8 MAINTENANCE SERVICE in this section.

### INSTALLATION

- If parking brake cable was removed and reinstalled, make sure to clamp it properly according to illustrated instruction for each clamp in the figure below.
- After installing cable, check the following;
  - \* Parking brake lever stroke is within specification
  - \* Parking brake operates properly
  - \* Brake is free from dragging

For stroke data and cable adjustment, refer to p. 19-44 and 19-45 under 19-8 MAINTENANCE SERVICE in this section.

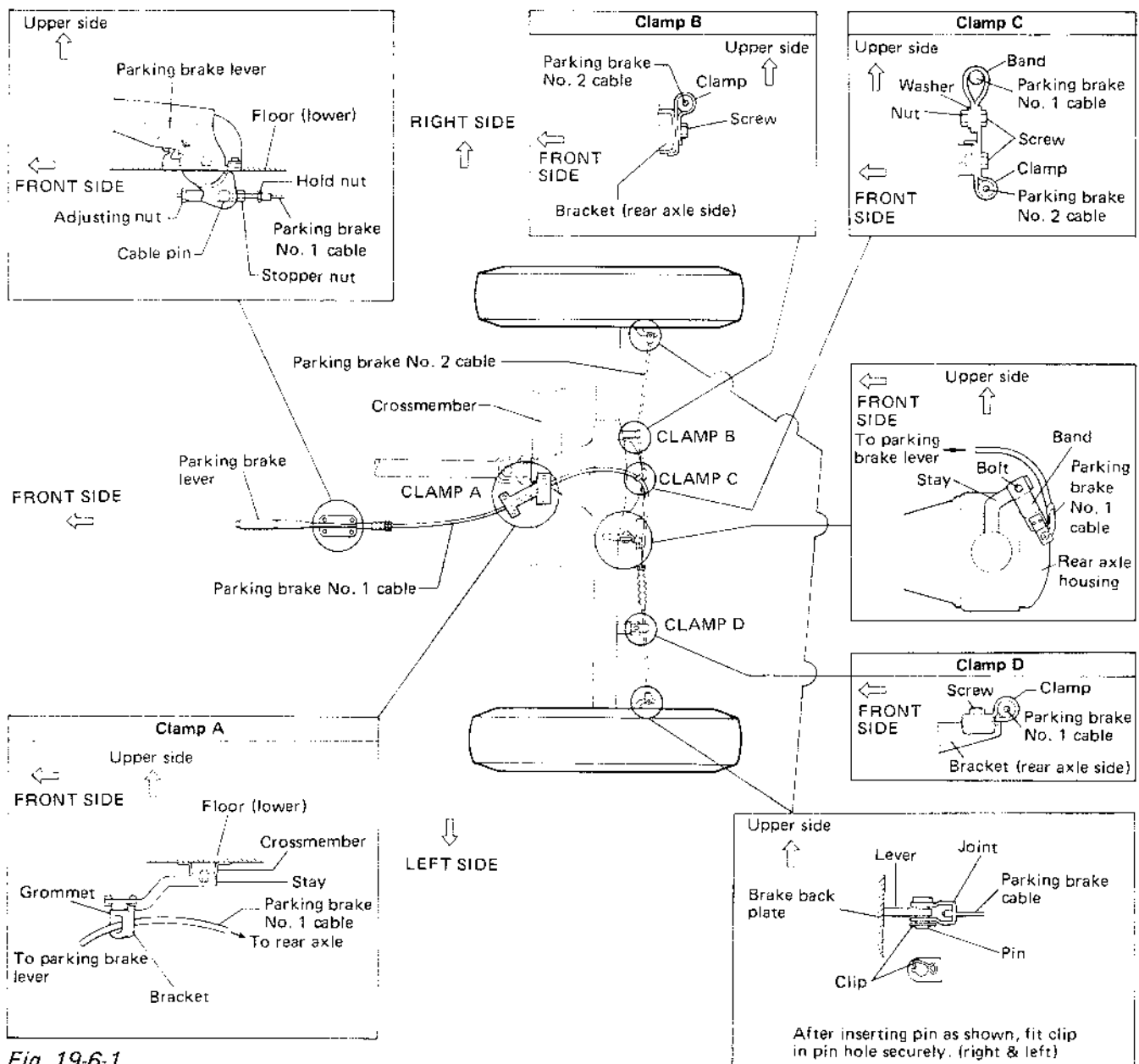


Fig. 19-6-1

## 19-7. BRAKE PIPES AND HOSES

### REMOVAL AND INSTALLATION

- 1) Take out fluid with a syringe or such.
- 2) Clean dirt and foreign material from both hose end or pipe end fittings. Remove brake hose or pipe.
- 3) Reverse removal procedure for brake hose or pipe installation. When installing hose, make sure that it has no twists or kinks. Inspect to see that hose doesn't make contact with any part of suspension. Check in extreme right and extreme left turn conditions. If hose makes any contact, remove and correct. Fill and maintain brake fluid level in reservoir. Bleed brake system.

### CAUTION:

- Refer to Fig. 19-38 when connecting brake flexible hose to brake caliper and tighten to specified torque.
- Be sure to install brake pipe in proper position referring to Fig. 19-7-2 and clamp it securely and correctly.

### Tightening torque

	N·m	kg·m	lb·ft
Brake pipe flare nuts	14 – 18	1.4 – 1.8	10.5 – 13.0
Brake flexible hose bolt	20 – 25	2.0 – 2.5	14.5 – 18.0
6-way joint bolt	6 – 10	0.6 – 1.0	4.5 – 7.0
Proportioning valve bolt	6 – 10	0.6 – 1.0	4.5 – 7.0
Proportioning valve plate bolt	6 – 10	0.6 – 1.0	4.5 – 7.0

### NOTICE:

- Be sure to install brake flexible hose E-ring into hose groove.

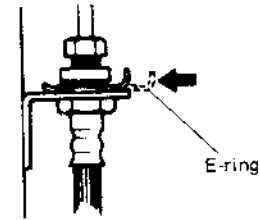
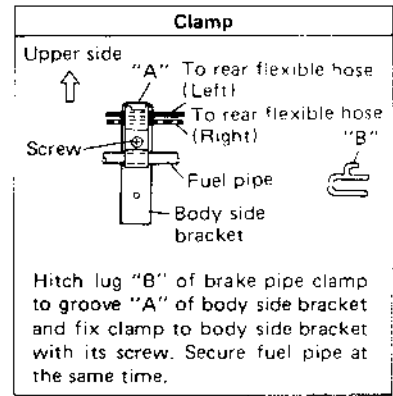
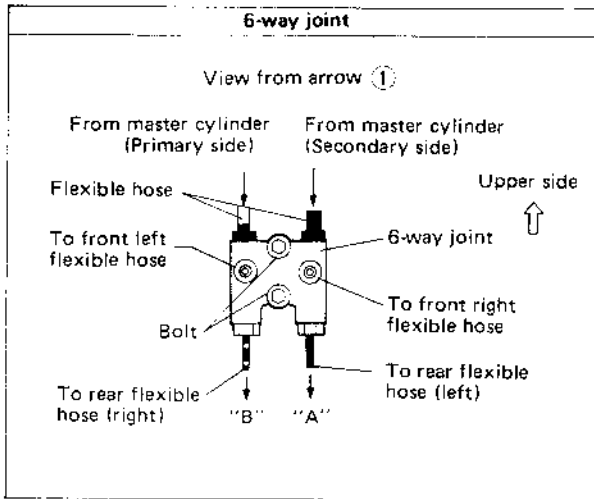


Fig. 19-7-1

- Upon completion of installation, check each joint for fluid leakage with brake pedal depressed.



**Brake flexible hose and E-ring**

- Make sure that flexible hose is not twisted when it is installed or connected to the pipe.
- When installing flexible hose to bracket, align 6 vertexes of metal fixture on hose with internal angles of bracket.
- Insert E-ring till E-ring end surface is flush with or lower than bracket end surface. (Refer to p. 19-39.)
- For installation of flexible hose to brake caliper, refer to p. 19-19.
- Install the flexible hose so that it won't be kinked when the steering wheel is straightened.  
After installing the flexible hose, turn the steering wheel to the right fully and check that the clearance between the wheel/tire and flexible hose is larger than 25 mm (0.984 in) in that state and then check likewise with the steering wheel turned to the full left position. (This is to ensure that more than 25 mm (0.984 in) clearance is maintained even when bumping or rebounding fully).

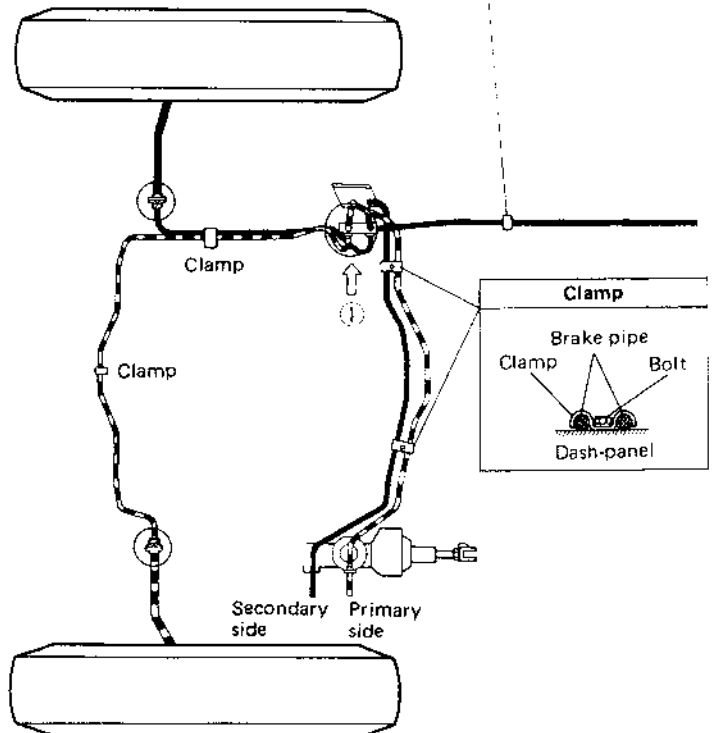
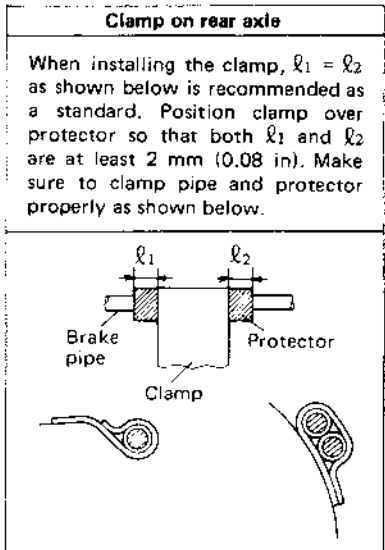
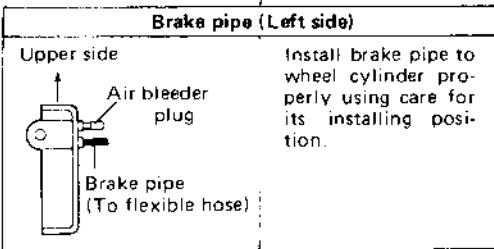
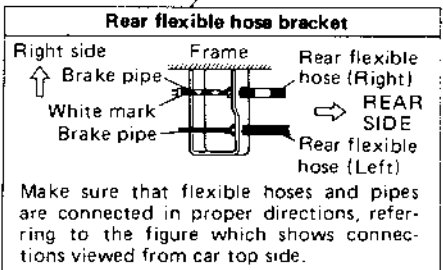
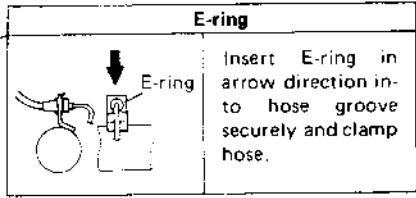
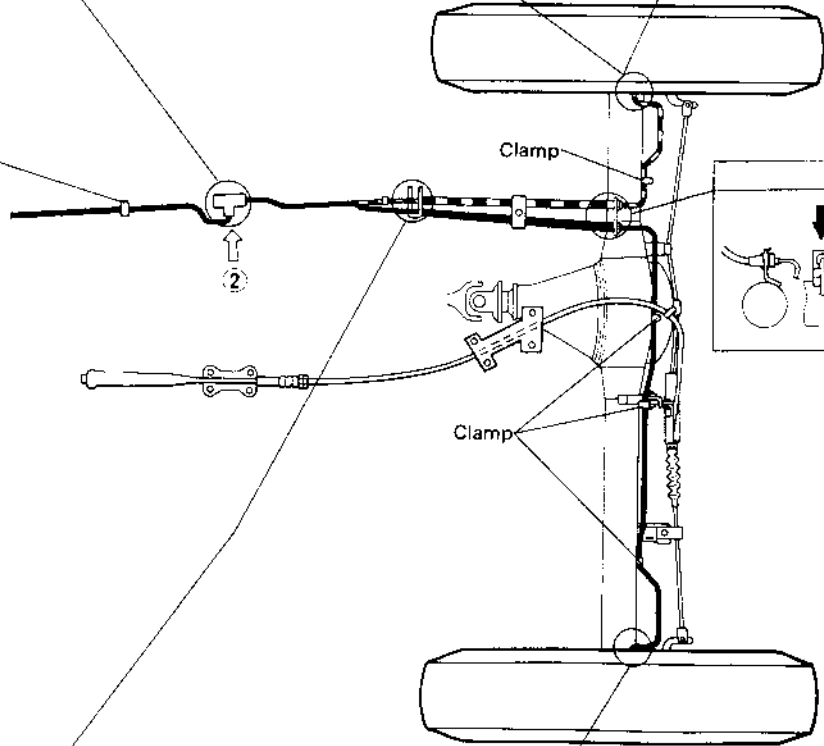
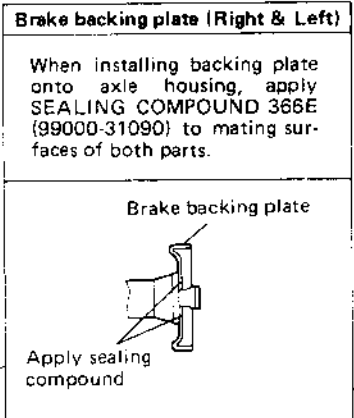
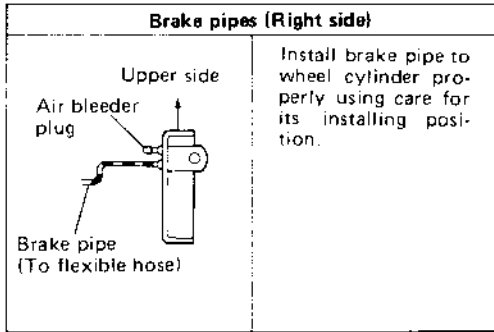
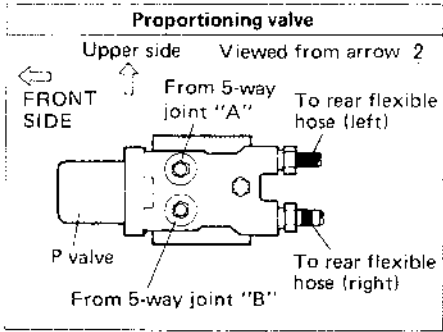


Fig. 19-7-2



## 19-8. MAINTENANCE SERVICE

### ROAD TESTING BRAKES

Brakes should be tested on dry, clean, smooth and reasonably level roadway which is not crowned. Road test brakes by making brake applications with both light and heavy pedal forces at various speeds to determine if the car stops evenly and effectively.

Also drive car to see if it leads to one side or the other without brake application. If it does, check tire pressure, front end alignment and front suspension attachments for looseness. See diagnosis chart for other causes.

### BRAKE FLUID LEAKS

Check master cylinder fluid levels. While a slight drop in reservoir level does result from normal lining wear, an abnormally low level indicates a leak in the system. In such a case, check the entire brake system for leakage. If even a slight evidence of leakage is noted, the cause should be corrected or defective parts should be replaced.

### BRAKE FLUID LEVEL INSPECTION

Be sure to use particular brake fluid either as marked on reservoir cap of that car or recommended in owner's manual which comes along with that car.

Use of any other fluid is strictly prohibited.

Fluid level should be between MIN and MAX lines marked on reservoir.

When warning light lights sometimes during driving, replenish fluid to MAX line.

When fluid decreases quickly, inspect brake system for leakage. Correct leaky points and then refill to specified level.

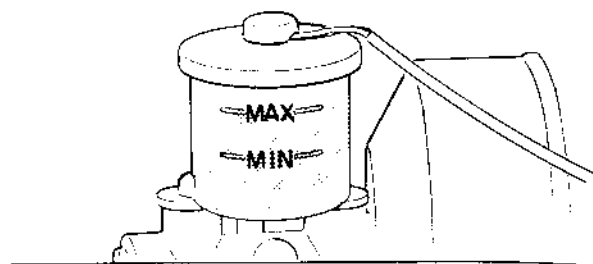


Fig. 19-8-1

### FILL RESERVOIR

#### CAUTION:

Do not use shock absorber fluid or any other fluid which contains mineral oil. Do not use a container which has been used for mineral oil or a container which is wet from water. Mineral oil will cause swelling and distortion of rubber parts in the hydraulic brake system and water will mix with brake fluid, lowering the fluid boiling point. Keep all fluid containers capped to prevent contamination.

Fluid to fill reservoir which is indicated on reservoir cap of the car with embossed letters or in owner's manual supplied with the car.

Add fluid up to MAX line.

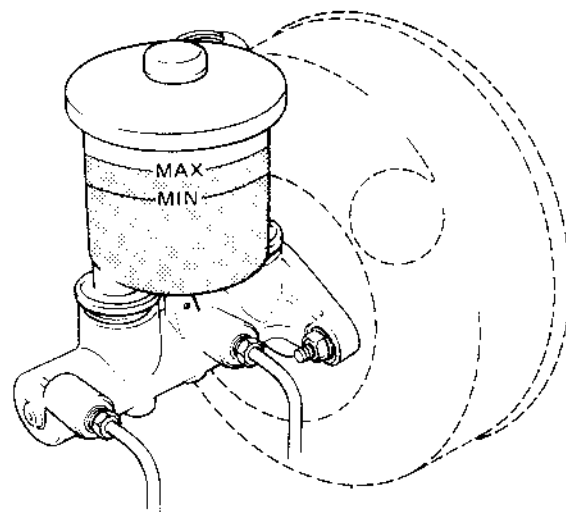


Fig. 19-8-2

## BRAKE PEDAL FREE HEIGHT ADJUSTMENT

Brake pedal height is normal if brake pedal is as high as clutch pedal.

- 1) When booster push rod clevis has been reinstalled, it is important that measurement between booster mounting surface (with a gasket attached) and the center of clevis pin hole is adjusted within 125.5 mm – 126.5 mm (4.94 – 4.98 in.). (See page 19-37.)
- 2) When stop light switch has been removed, refer to the following STOP LIGHT SWITCH ADJUSTMENT for proper installation. The services in above steps 1) and 2) may affect brake pedal height.

## STOP LIGHT SWITCH ADJUSTMENT

Adjustment should be made as follows when installing the switch.

Pull up brake pedal toward you and while holding it there, adjust switch position so that clearance between the end of thread and brake pedal contact plate (shown as "A" in figure) is within 0.5 – 1.0 mm (0.02 – 0.04 in.). Then tighten lock nut to specified torque.

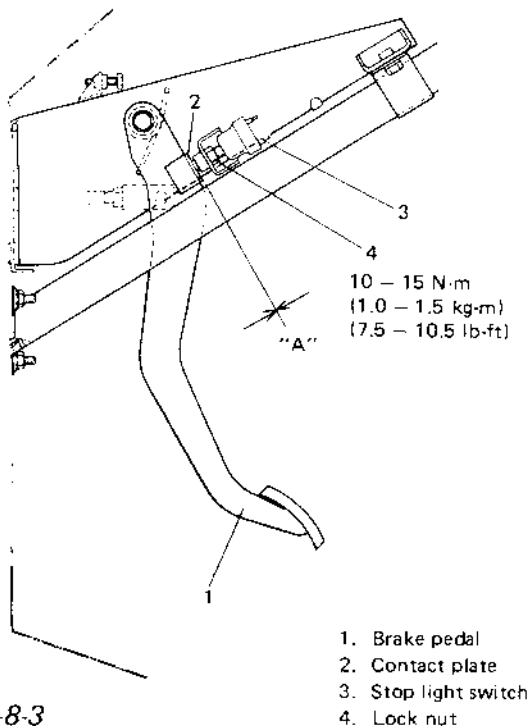


Fig. 19-8-3

## EXCESSIVE PEDAL TRAVEL CHECK

- 1) Start the engine.
- 2) Depress brake pedal a few times.
- 3) With brake pedal depressed with approximately 30 kg (66 lbs) load, measure pedal arm to wall clearance "B". It mustn't be less than 75 mm (2.95 in.).

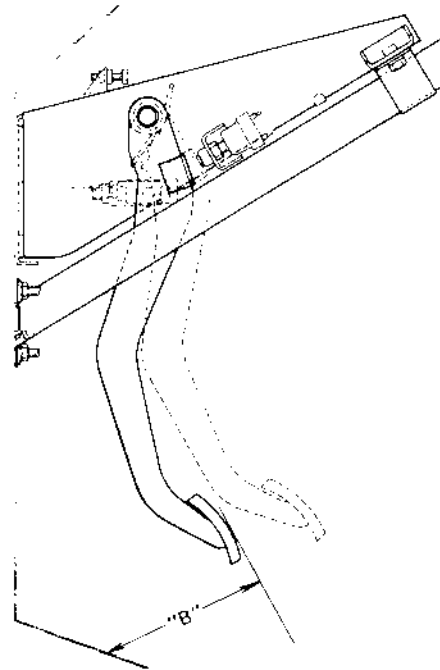


Fig. 19-8-4

- 4) If clearance "B" is less than 75 mm (2.95 in.), the most possible cause is either rear brake shoes are worn out beyond limit or air is in lines.

Should clearance "B" remain less than 75 mm (2.95 in.) even after replacement of brake shoes and bleeding of system, other possible but infrequent cause is malfunction of rear brake shoe adjusters or booster push rod length out of adjustment for the car with brake booster.

- See p. 19-22 for brake shoe inspection.
- See p. 19-46 for bleeding brake system.
- Remove brake drums for adjuster inspection. (See p. 19-23.) If defective, correct or replace.

## BRAKE HOSE AND PIPE INSPECTION

### Hose

The brake hose assembly should be checked for road hazard damage, for cracks and chafing of outer cover, for leaks and blisters. A light and mirror may be needed for an adequate inspection. If any of the above conditions are observed on brake hose, it will be necessary to replace it.

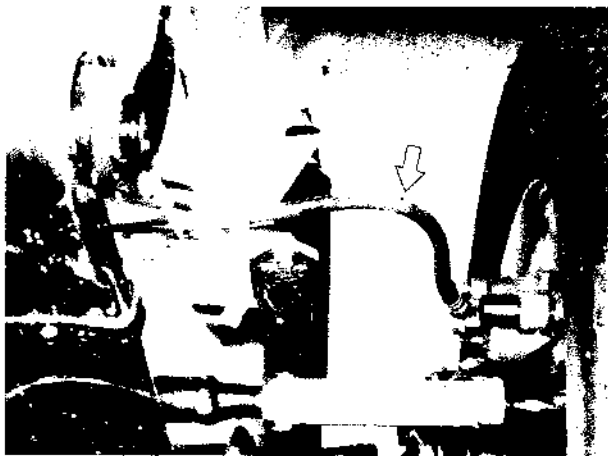


Fig. 19-8-5

### Pipe

Inspect the tube for damage, cracks, dents and corrosion. If any defect is found, replace it.



Fig. 19-8-6

## PAD LINING INSPECTION

Inspect pad linings periodically according to maintenance schedule and whenever wheels are removed (for tire rotation or other reason). For wear check of pad linings, refer to p. 19-16.

## DISC INSPECTION

Inspect disc periodically according to maintenance schedule.

For more information, refer to p. 19-17.

## REAR BRAKE SHOE & LINING INSPECTION

Inspect brake shoe & lining according to maintenance schedule.

For shoe and lining inspection, refer to p. 19-22.

## REAR BRAKE DRUM INSPECTION

Inspect brake drum according to maintenance schedule.

For more information, refer to p. 19-21.

## PARKING BRAKE INSPECTION AND ADJUSTMENT

### 1) Parking brake lever stroke inspection.

Hold the center of parking brake lever grip and pull it up with 20 to 25 kg (44 to 55 lb) force.

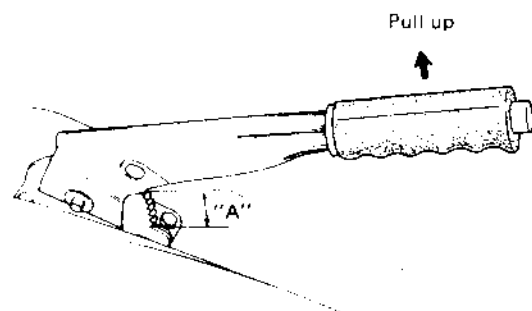
With parking brake lever pulled up as above, count ratchet notches in "A" as shown in figure. There should be 3 to 8 notches.

Also, check if both right and left rear wheels are locked firmly.

If number of notches is out of specification, adjust cable by referring to adjustment procedure described on the next page so as to obtain specified parking brake stroke.

### NOTICE:

Check tooth tip of each notch for damage or wear. If any damage or wear is found, replace parking brake lever.



Parking brake stroke "A": When lever is pulled up at 20 kg (44 lb).	Within 3-8 notches
--	--------------------------

Fig. 19-8-7



## 2) Parking brake lever stroke adjustment

- a) If parking brake lever stroke was found out of specification when checked as described on the previous page, adjust parking brake cable.

### NOTICE:

Make sure for following conditions before cable adjustment.

- No air is trapped in brake system.
- Brake pedal travel is proper.
- Brake pedal has been depressed a few times with about 30 kg (66 lbs) load.
- Parking brake lever has been pulled up a few times with about 20 kg force.
- Rear brake shoes are not worn beyond limit, and self adjusting mechanism operates properly.

- b) After confirming that above 5 conditions are all satisfied, adjust parking brake lever stroke by loosening or tightening adjusting nut indicated in figure and tighten stopper nut to the pin.

### NOTICE:

- For cable adjustment, loosen stopper nut and turn adjusting nut while holding hold nut with spanner so as to prevent inner cable from getting twisted.
- Check brake drum for dragging after adjustment.

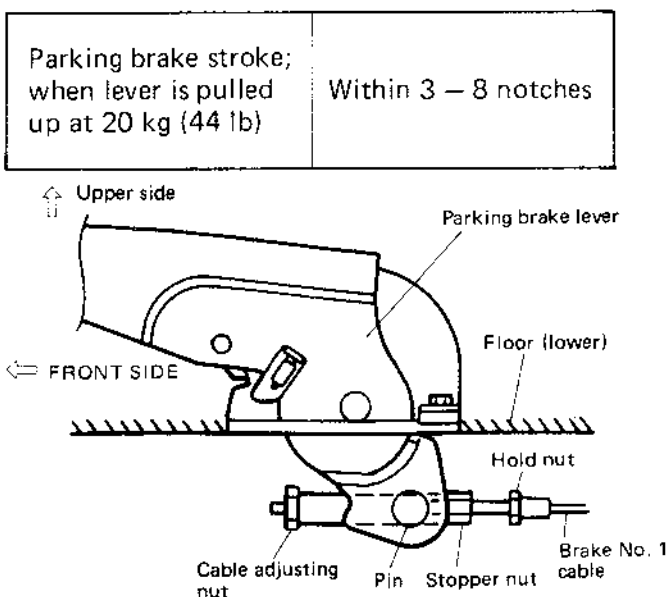


Fig. 19-8-8

## 3) Parking brake cable inspection

Check brake cable for damage and also for smooth movement. Replace if deteriorated.

## BRAKE PEDAL PLAY INSPECTION

Pedal play should be within below specification. If out of specification, check stop light switch for proper installation position and adjust if necessary.

Also check pedal shaft bolt and master cylinder pin installation for looseness and replace if defective.

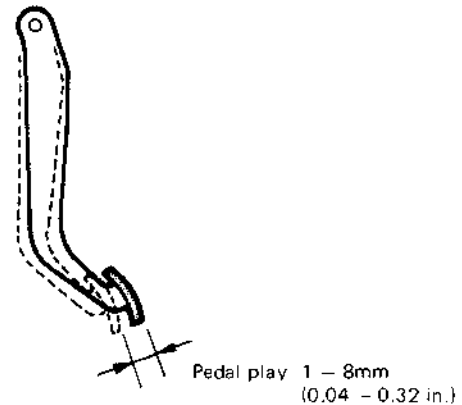


Fig. 19-8-9

## REAR DRUM BRAKE SHOE ADJUSTMENT

Rear brake has self-adjusting mechanism but it does require adjustment for proper drum to shoe clearance when brake shoe has been replaced or brake drum has been removed for some other service.

Adjustment is automatically accomplished by depressing brake pedal 3 to 5 times with approximately 30 kg (66 lbs) load after all parts are installed.

Then check brake drum for dragging and brake system for proper performance. After lowering car from lift, brake test should be performed.

## FLUSHING BRAKE HYDRAULIC SYSTEM

It is recommended that entire hydraulic system be thoroughly flushed with clean brake fluid whenever new parts are installed in hydraulic system.

Periodical change of brake fluid is also recommended.

## BLEEDING BRAKES

### NOTICE:

Brake fluid is extremely damaging to paint. If fluid should accidentally touch painted surface, immediately wipe fluid from paint and clean painted surface.

A bleeding operation is necessary to remove air whenever it entered hydraulic brake system.

The hydraulic lines of this brake system are based on the diagonal split system. When a brake pipe or hose was disconnected at the wheel, bleeding operation must be performed at both ends of the line of the removed pipe or hose. When any joint part of the master cylinder or other joint part between the master cylinder and each brake (wheel) was removed, the hydraulic brake system must be bled at all 4 wheel brakes.

### NOTICE:

Perform bleeding operation starting with wheel cylinder farthest from master cylinder and then at front caliper of the same brake line. Do the same on the other brake line.

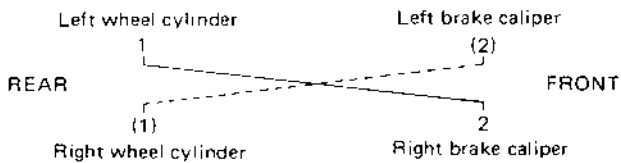


Fig. 19-8-10

- 1) Fill master cylinder reservoir with brake fluid and keep at least half filled during bleeding operation.
- 2) Remove bleeder plug cap. Attach vinyl tube to bleeder plug of wheel cylinder, and insert the other end into container.

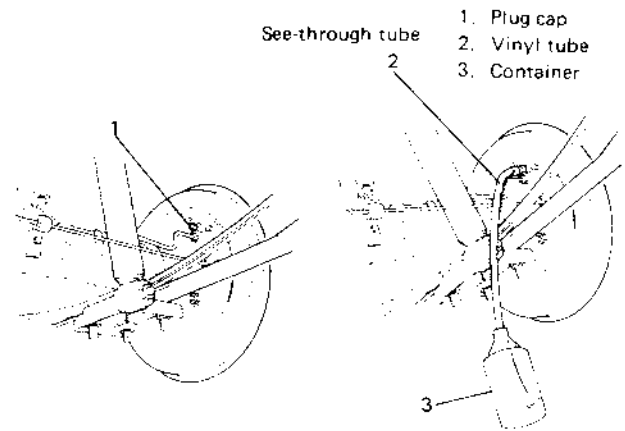
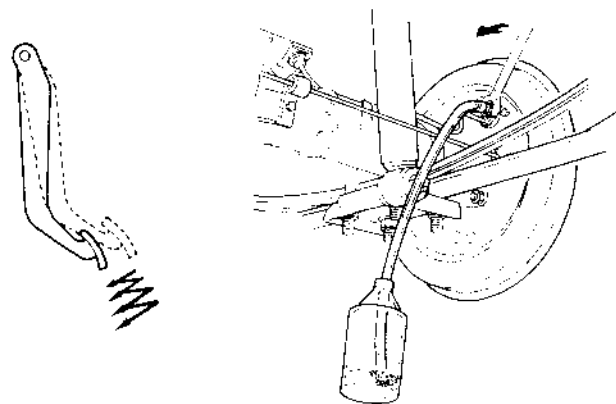


Fig. 19-8-11

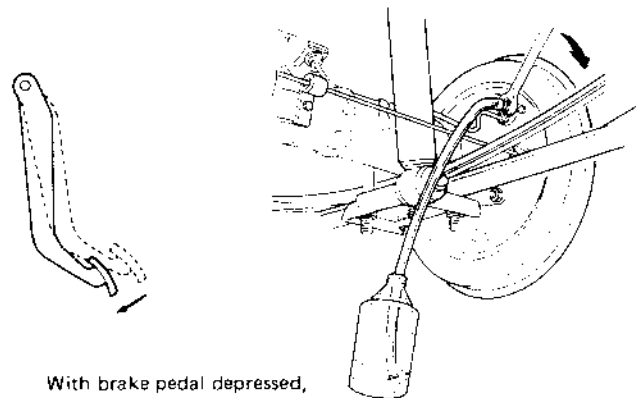
- 3) Depress brake pedal several times, and then while holding it depressed, loosen bleeder plug about one-third to one-half turn.



Depress brake pedal several times and with pedal depressed, loosen bleeder plug a little.

Fig. 19-8-12

- 4) When fluid pressure in the cylinder is almost depleted, retighten bleeder plug.



With brake pedal depressed, retighten bleeder plug.

Fig. 19-8-13

- 5) Repeat this operation until there are no more air bubbles in hydraulic line.
- 6) When bubbles stop, depress and hold brake pedal and tighten bleeder plug.
- 7) Then attach bleeder plug cap.

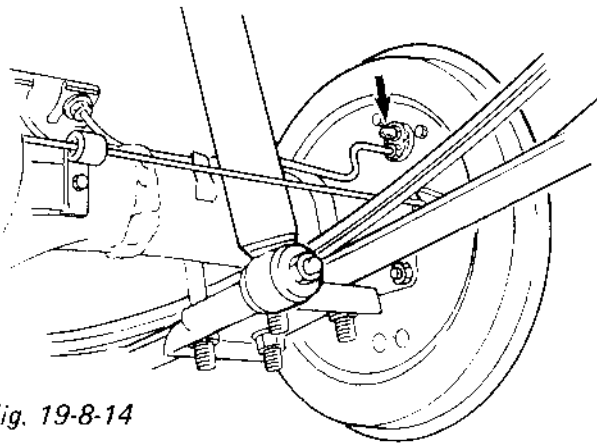


Fig. 19-8-14

- 8) After completing bleeding operation, apply fluid pressure to pipe line and check for leakage.
- 9) Replenish fluid into reservoir up to specified level.

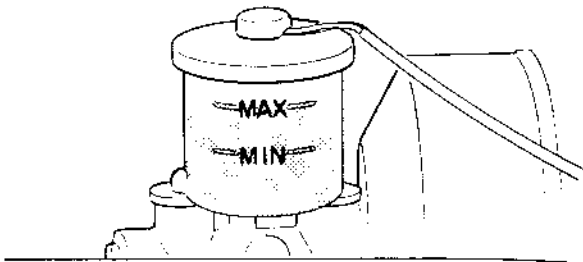


Fig. 19-8-15

- 10) Check brake pedal for "sponginess". If found spongy, repeat entire procedure of bleeding.

## INSPECT BOOSTER OPERATION

There are two ways to perform this inspection, with and without a tester. Ordinarily, it is possible to roughly determine its condition without using a tester.

### NOTICE:

For this check, make sure that no air is in hydraulic line.

## INSPECTION WITHOUT TESTER

### Check Air Tightness

- 1) Start engine.
- 2) Stop engine after running for 1 or 2 minutes.
- 3) Depress brake pedal several times with the same load as in ordinary braking and observe pedal travel. If pedal goes down deep the first time but its travel decreases as it is depressed the second and more times, air tightness is obtained.

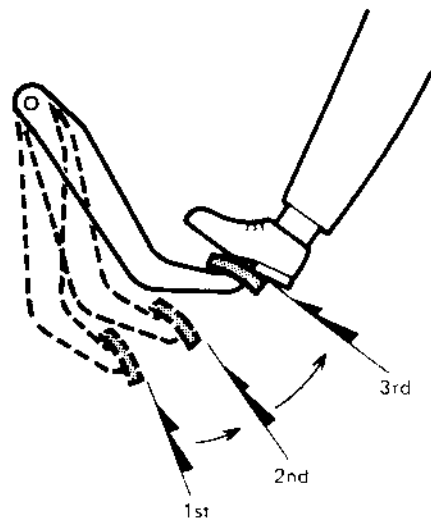
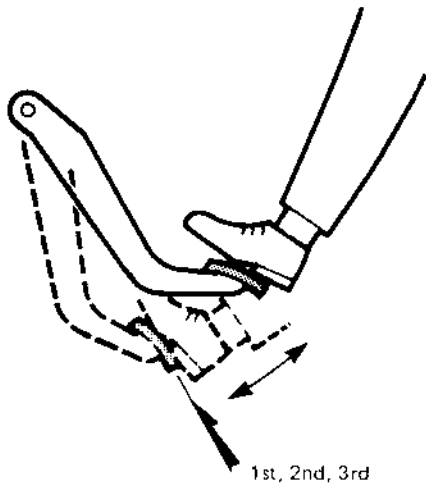


Fig. 19-8-16

4) If pedal travel doesn't change, air tightness isn't obtained.



NO GOOD

Fig. 19-8-17

**NOTICE:**

If defective, inspect vacuum lines and sealing parts, and replace any faulty part. When this has been done, repeat the entire test!

**Check Operation**

1) With engine stopped, depress brake pedal several times with the same load and make sure that pedal travel doesn't change.

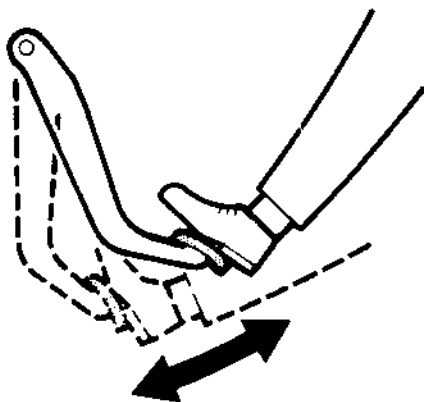


Fig. 19-8-18

2) Start engine while depressing brake pedal. If pedal travel increases a little, operation is satisfactory. But no change in pedal travel indicates malfunction.

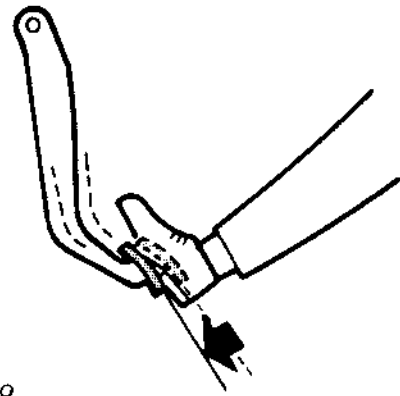


Fig. 19-8-19

**Check Air Tightness Under Load**

1) With engine running, depress brake pedal. Then stop engine while holding brake pedal depressed.

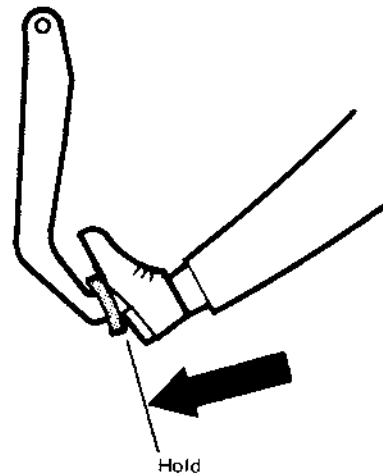


Fig. 19-8-20

2) Hold brake pedal depressed for 30 seconds. If pedal height does not change, condition is good. But it isn't if pedal rises.

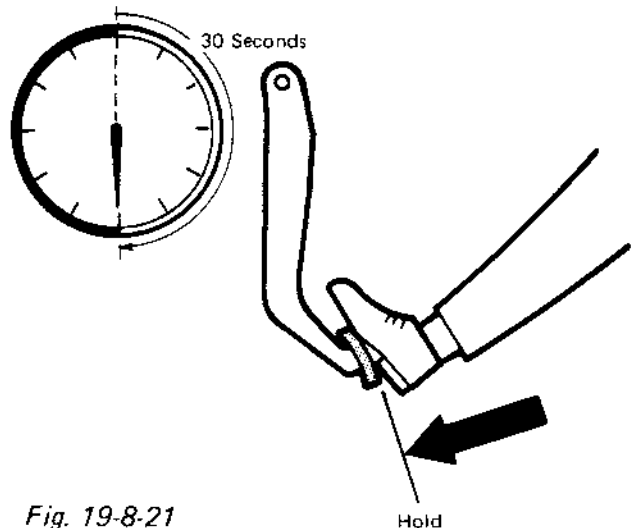


Fig. 19-8-21

## 19-9. TORQUE SPECIFICATION

Fastening parts	Tightening torque		
	N·m	kg·m	lb·ft
1. Brake caliper holder bolt	40 – 60	4.0 – 6.0	29.0 – 43.0
2. Brake carrier bolt	70 – 100	7.0 – 10.0	51.0 – 72.0
3. Brake caliper guide pin	25 – 30	2.5 – 3.0	18.5 – 21.5
4. Brake nut (Brake back plate nut)	18 – 28	1.8 – 2.8	13.5 – 20.0
5. Master cylinder nut	10 – 16	1.0 – 1.6	7.5 – 11.5
6. Booster nut	10 – 16	1.0 – 1.6	7.5 – 11.5
7. Brake pipe 6-way joint bolt	6 – 10	0.6 – 1.0	4.5 – 7.0
8. Brake flare nut	14 – 18	1.4 – 1.8	10.5 – 13.0
9. Brake pedal shaft nut	18 – 28	1.8 – 2.8	13.5 – 20.0
10. Universal joint flange nut	23 – 30	2.3 – 3.0	17.0 – 21.5
11. Brake flexible hose bolt	20 – 25	2.0 – 2.5	14.5 – 18.0
12. Proportioning valve bolt	6 – 10	0.6 – 1.0	4.5 – 7.0
13. Proportioning valve plate bolt	6 – 10	0.6 – 1.0	4.5 – 7.0
14. Brake flexible hose nut	20 – 40	2.0 – 4.0	14.5 – 28.5
15. Front brake caliper air bleeder plug	7 – 12	0.7 – 1.2	5.5 – 8.5



# SECTION 20

## BODY SERVICE

### CONTENTS

<b>20-1. FRONT DOOR</b> .....	<b>20-2</b>
DESCRIPTION .....	20-2
REMOVAL .....	20-3
INSTALLATION .....	20-5
<b>20-2. WINDSHIELD</b> .....	<b>20-8</b>
CLEANING .....	20-8
INSTALLATION .....	20-9
<b>20-3. BACK DOOR (APPLICABLE TO HARD TOP VEHICLE)</b> .....	<b>20-11</b>
<b>20-4. CHASSIS DIMENSIONS</b> .....	<b>20-13</b>

# 20-1. FRONT DOOR

## DESCRIPTION

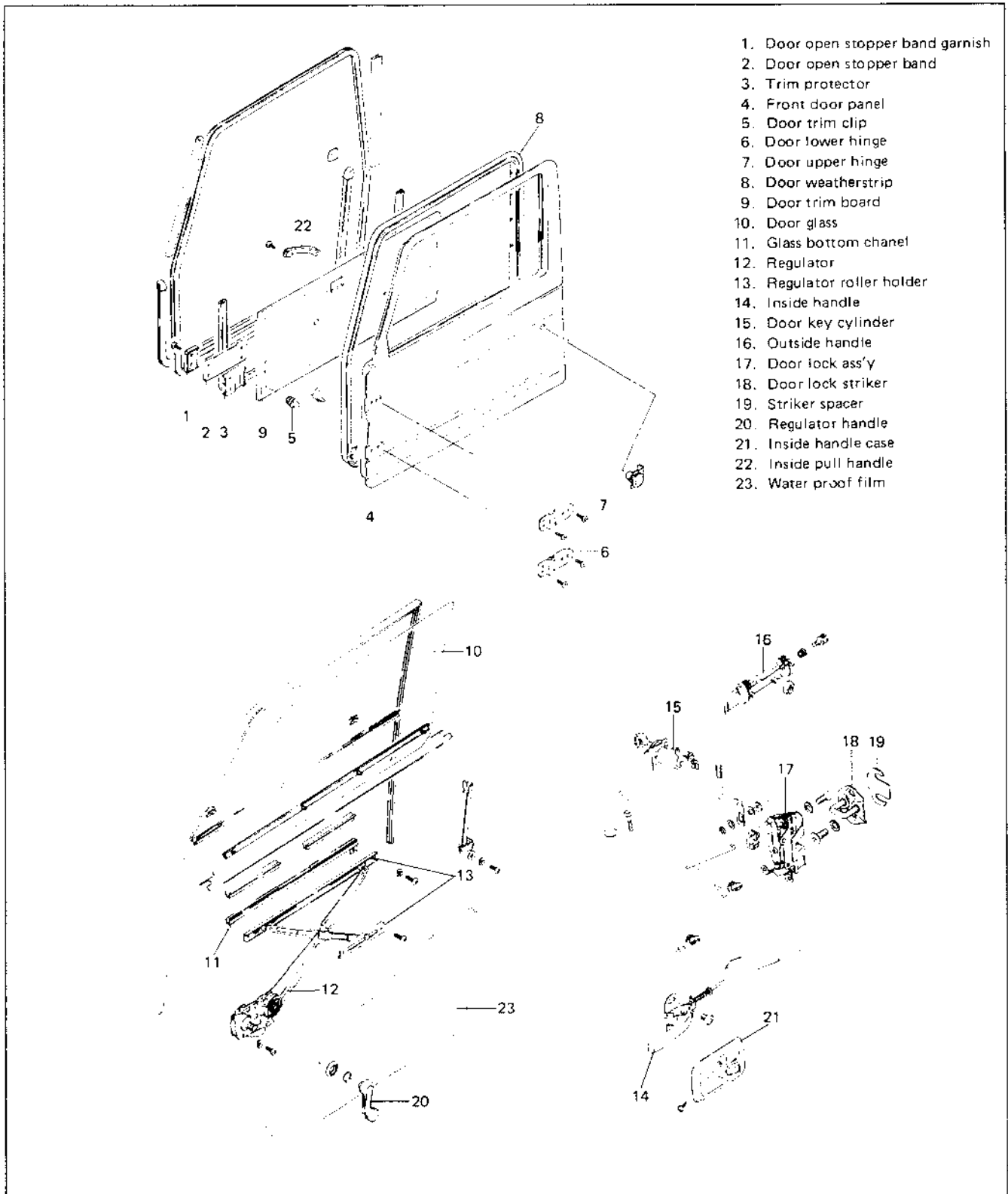


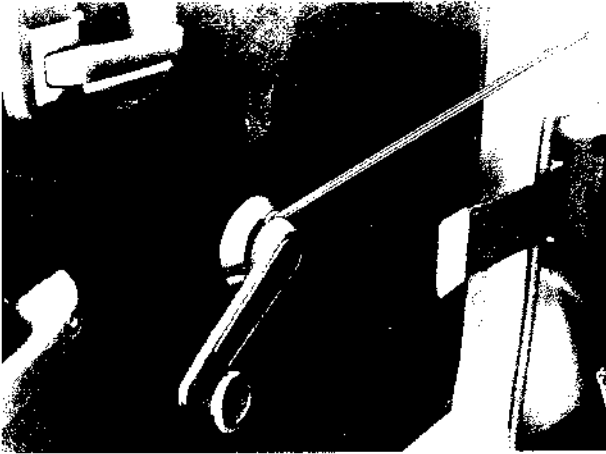
Fig. 20-1-1



## REMOVAL

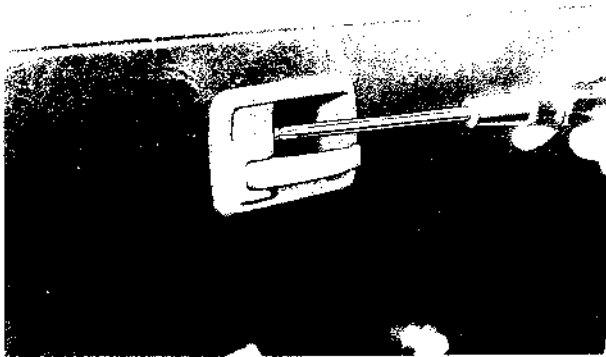
### Door Window Glass

1) Remove door window regulator handle.



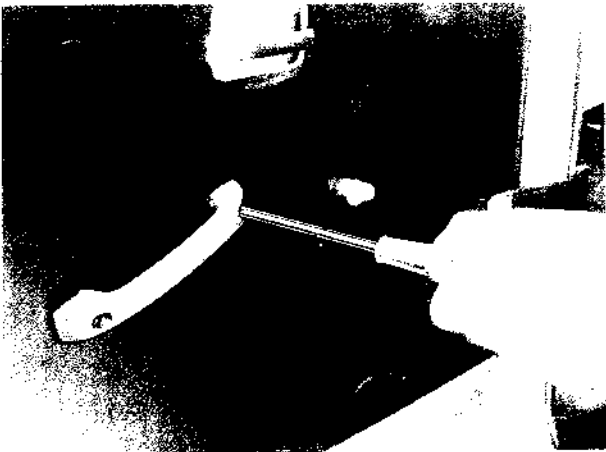
*Fig. 20-1-2*

2) Remove inside handle case.



*Fig. 20-1-3*

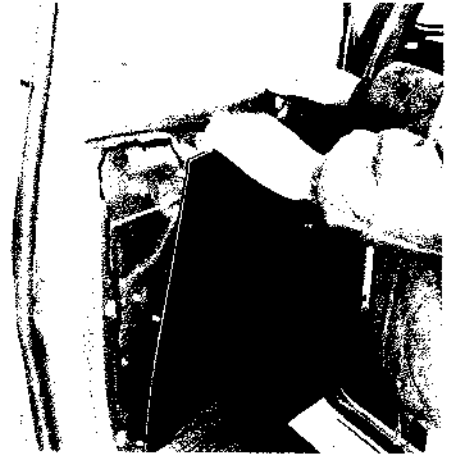
3) Remove inside pull handle.



*Fig. 20-1-4*

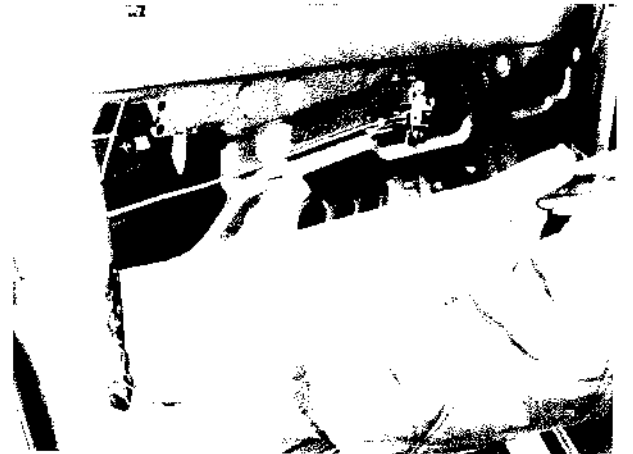
4) Loosen two screws securing the stopper band, and take off the band.

5) Remove door trim board.



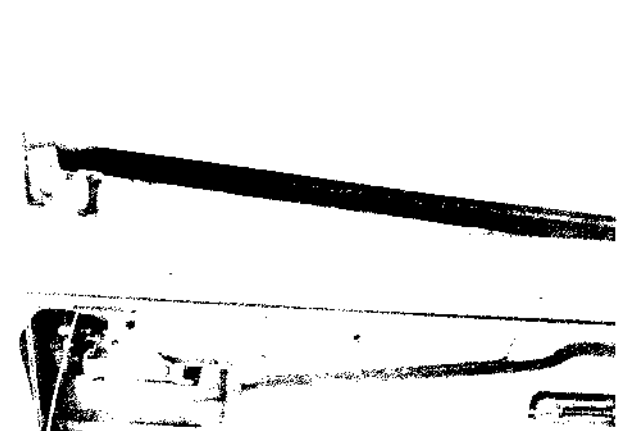
*Fig. 20-1-5*

6) Remove the door water proof film.



*Fig. 20-1-6*

7) Remove the glass inside and outside scrape.



*Fig. 20-1-7*

8) Remove 2 screws securing the door window regulator roller holder (lower side).

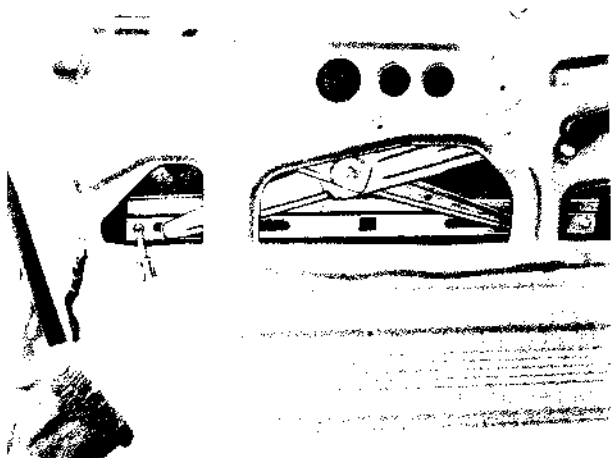


Fig. 20-1-8

9) Take out the glass.

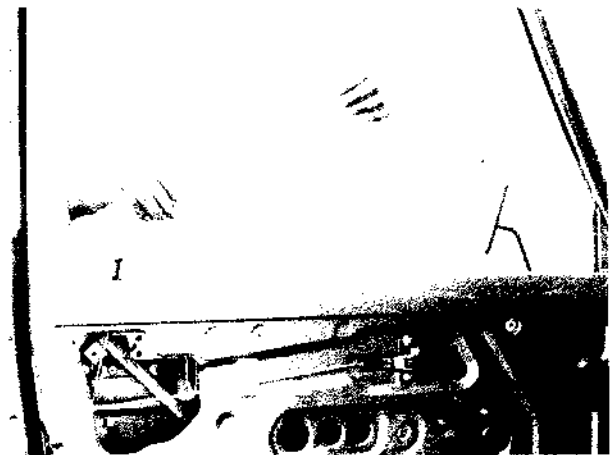


Fig. 20-1-9

10) Detach glass from bottom channel.

### Door Window Regulator

After carrying out door glass removal steps 1) through 6) and 8), move on to the following steps to take off the door window regulator.

1) Remove 2 screws securing the door window regulator roller holder (upper side).

### NOTICE:

Make sure to support the glass to keep it from falling while removing the screws.

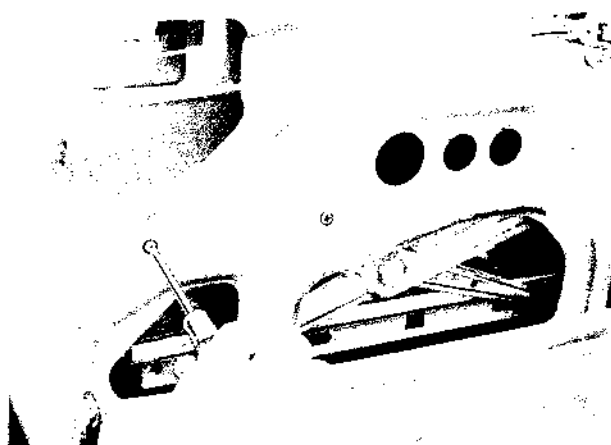


Fig. 20-1-10

2) Remove 4 screws securing the window regulator.

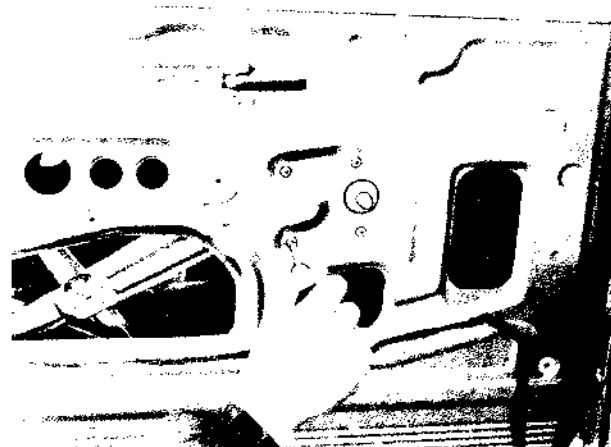


Fig. 20-1-11

3) Remove the window regulator.

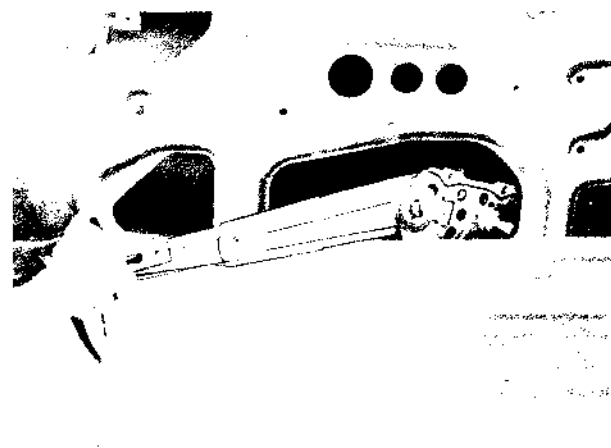


Fig. 20-1-12

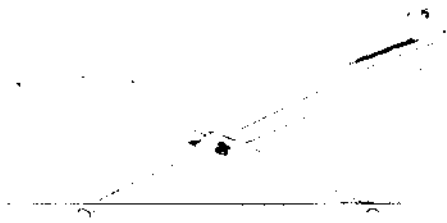
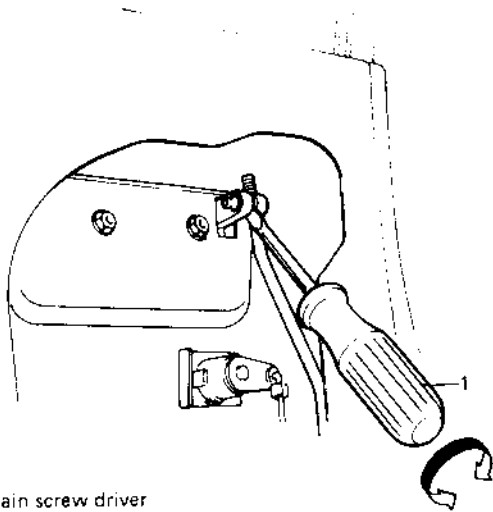


Fig. 20-1-13

### Front Door Lock

After carrying out steps 1) through 6) of door glass removal, move on to the following step to take off the door lock.

After disconnecting each joint of control link, remove the door inside handle and door lock ass'y.



1. Plain screw driver

Fig. 20-1-14

## INSTALLATION

### Door Window Glass or Regulator

Reverse the removal sequence to install the door window glass or regulator. However, be careful of the following points.

[Door window regulator]

When installing door window regulator to door panel, apply multi-purpose grease to the sliding parts.

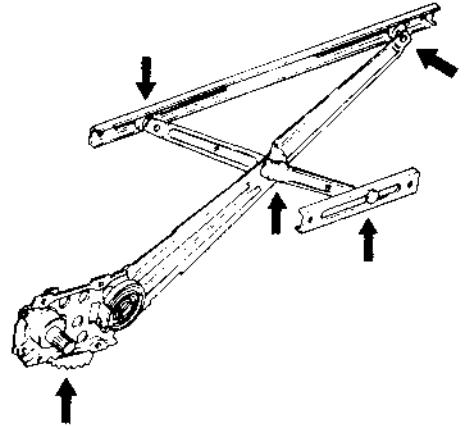


Fig. 20-1-15

[Door glass]

When fitting the glass bottom channel on the door glass, adjust the distance between the glass end ① and channel end ② to that indicated below.

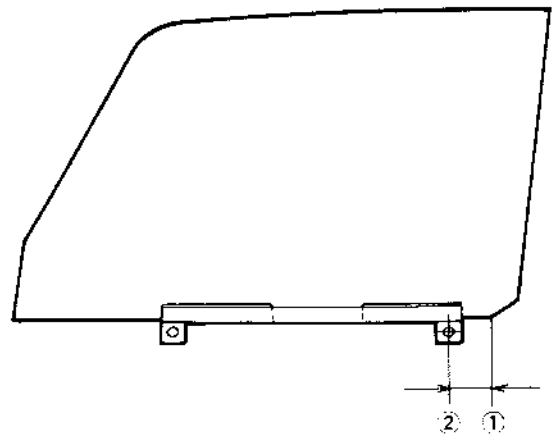


Fig. 20-1-16

42 mm (1.65 in.)

When it is hard to raise and lower the door glass, the glass may be slanting towards the door sash. If this is the case, loosen the screws fastening the door regulator roller holder, move the holder up and down so that the glass and sash are brought in parallel.

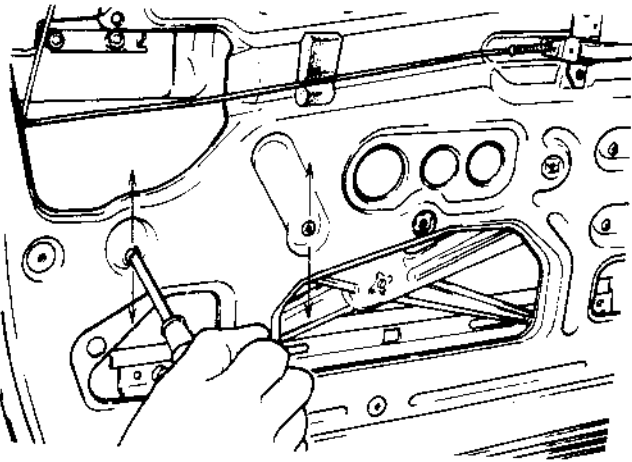


Fig. 20-1-17

[Water proof film]

A proof film that is broken a little may be mended with vinyl tape but should be replaced with polyethylene film as a rule. Apply bonding agent all around the circumference and stick on from the underside.

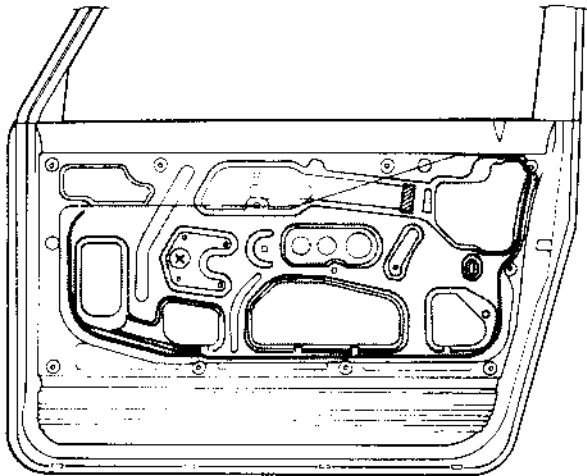


Fig. 20-1-18

[Regulator handle]

Install the handle at the angle as specified in below figure with the door window glass closed (raised all the way up).

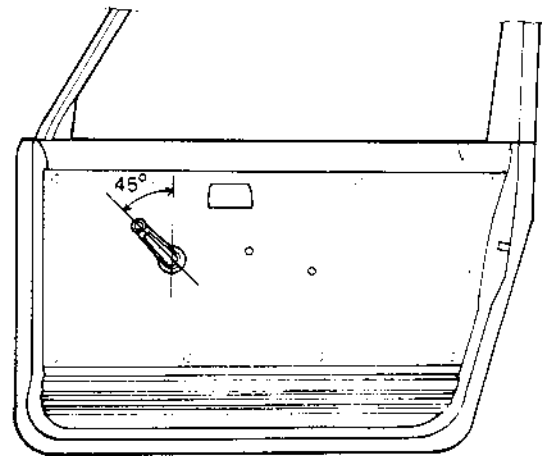


Fig. 20-1-19

Front Door Lock

Reverse the removal sequence to install the door lock. However, be careful of the following points.

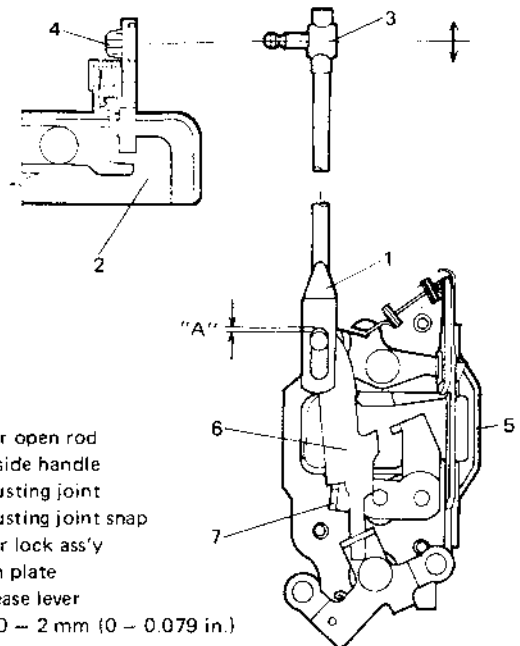
[Door outside open rod]

When installing open rod ① on outside handle ②, adjust clearance "A" to 0 – 2 mm (0 – 0.079 in) by turning adjusting joint ③.

NOTICE:

Don't push down push plate ⑥ when installing the open rod.

After installing the open rod, give the outside handle a trial and check if its play felt then is appropriate.



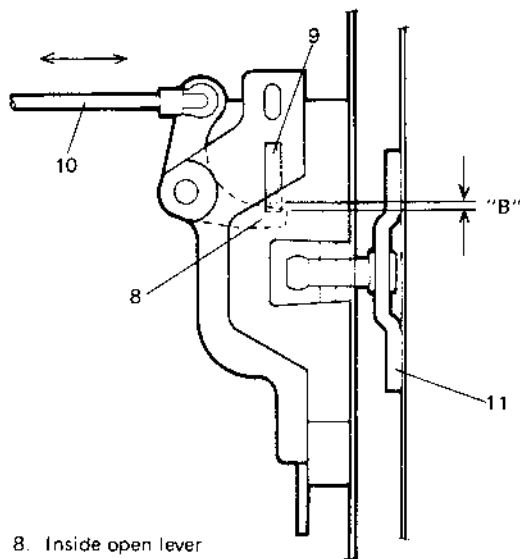
1. Door open rod
  2. Outside handle
  3. Adjusting joint
  4. Adjusting joint snap
  5. Door lock ass'y
  6. Push plate
  7. Release lever
- "A" : 0 – 2 mm (0 – 0.079 in.)

Fig. 20-1-20

[Door lock inside handle]

Fit the inside handle, adjusting the clearance between inside open lever ⑧ and outside open lever ⑨ of the door lock to 0 – 2 mm (0 – 0,079 in) by moving the inside handle remote control rod ⑩ in the arrow direction given in below figure.

After installation, give it a trial and check if its play felt then is appropriate.



- 8. Inside open lever
  - 9. Outside open lever
  - 10. Control rod
  - 11. Door lock striker
- "B" : 0 – 2 mm (0 – 0.079 in.)

Fig. 20-1-21

[Door lock rod pin]

Fix the lock rod with rod pin securely as illustrated below.

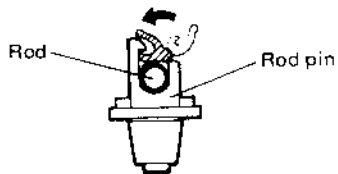


Fig. 20-1-22

[Door lock striker]

Increase or decrease striker spacers fitted in "A" position behind the striker to adjust dimensions to below values as shown in below figure.

After adjustment, check the difference in level between the door and body and adjust when there is difference by moving the door lock striker to right or left.

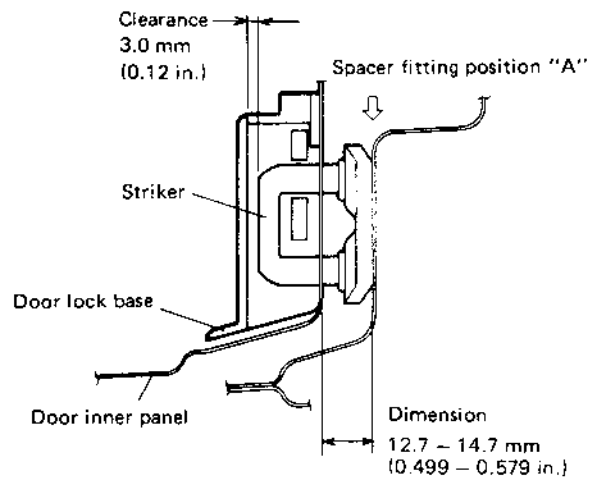


Fig. 20-1-23

Move the striker base up and down so that striker shaft aligns with the center of the groove of the door lock (the clearance between the shaft of door lock striker and lock base is 1.0 mm (0.04 in.)) in the vertical direction.

**CAUTION:**

- The striker should be placed vertically.
- Do not adjust the door lock.

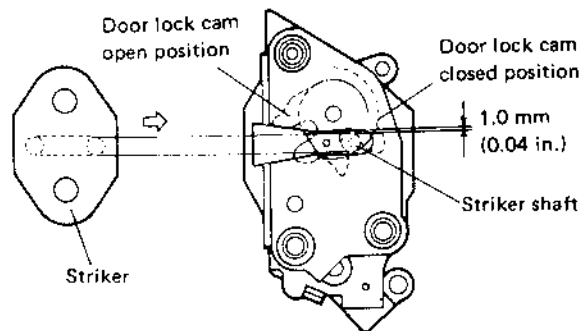


Fig. 20-1-24

## 20-2. WINDSHIELD

The windshield glass is bonded to the window panel (body) with weatherstrip in position. When replacing the glass, it is necessary to perform correct operation and adhesive selection so that adequate bonding strength can be obtained.

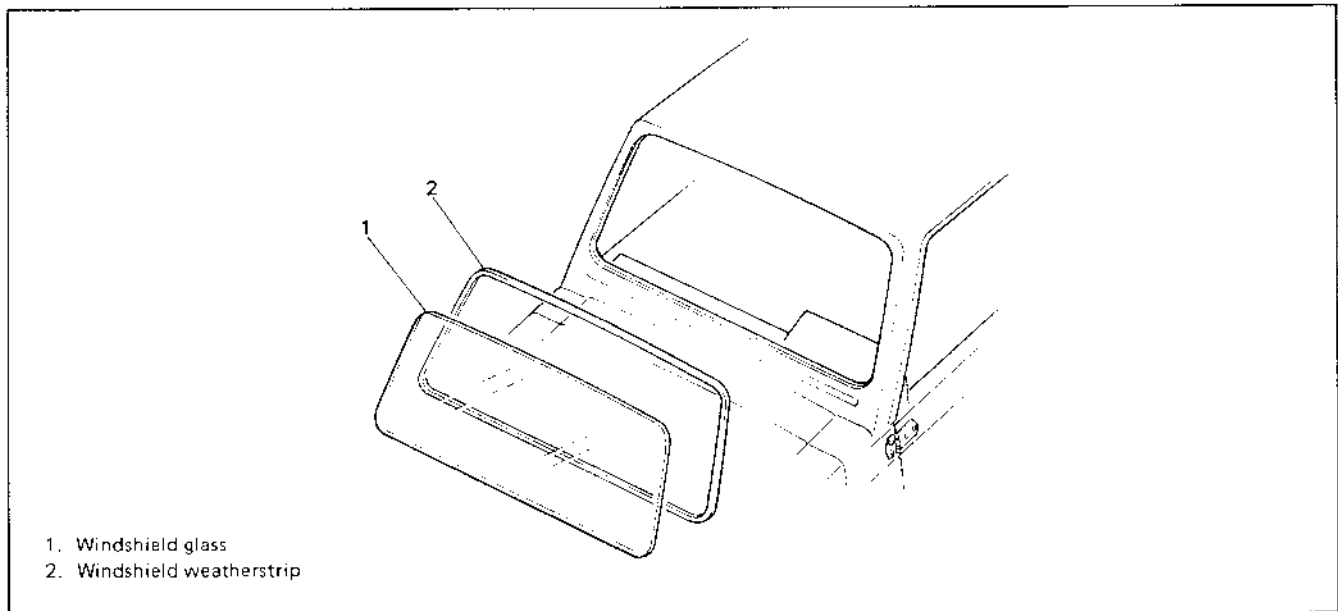


Fig. 20-2-1

### CLEANING

1) After removing the glass, remove the urethane gum sticking to the glass and window panel (body).

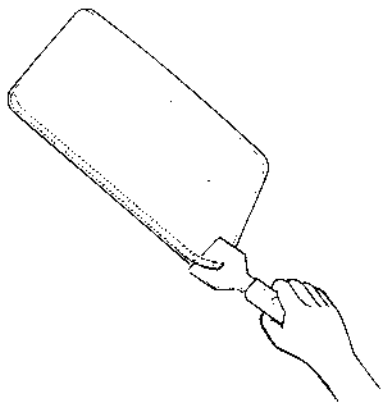
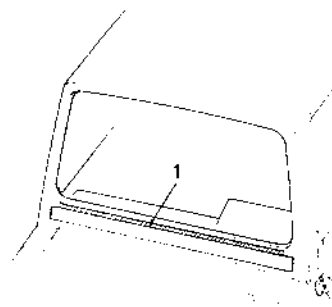


Fig. 20-2-2

#### NOTICE:

When removing the urethane gum from the window panel (body), apply a masking tape along the edge of the gummed surface to protect the painted surface from damage.



1. Urethane gum

Fig. 20-2-3

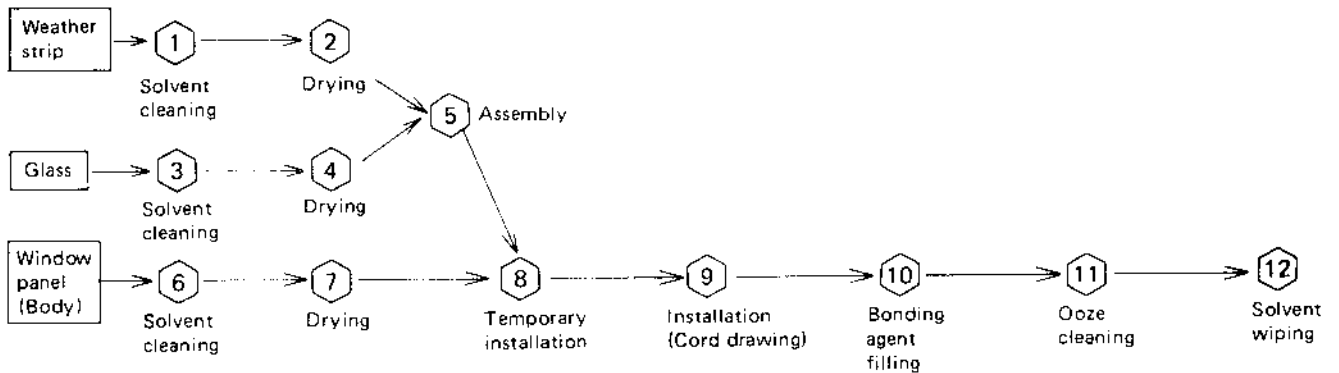
2. Use cleaning solvent to clean the glass and window panel (body).

#### NOTICE:

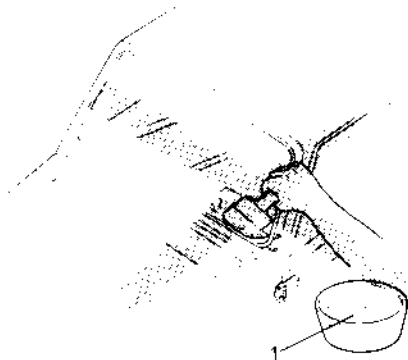
The use of alcohol or thinner when cleaning may adversely affect some kinds of adhesives in terms of bonding strength, resulting in that it is impossible to obtain adequate strength for glass installation. So, be careful sufficiently about the selection of the cleaning solvent.

## INSTALLATION

The installation sequence is shown in the Block Diagram below.



- 1) As for the cleaning, use cleaning solvent. The use of alcohol or thinner adversely affects some kinds of adhesives in terms of bonding strength. Hence, use sufficient care to select proper cleaning solvent.
- 2) When cleaning the weatherstrip, apply a 3 kg or more pressure on a clean cloth to wipe and clean it.
- 3) After cleaned with solvent, each item should not be touched by hand fouled with grease, etc.
- 4) Make a glass-and-weatherstrip assembly. Thereafter, carefully keep the assembly free from dust to assemble it to the window panel (body) as soon as possible.
- 5) Glass installation  
When assembling the glass into the weatherstrip's glass channel, and when assembling the glass-and-weatherstrip assembly to the window panel (body) soapy water must not be used as lubricant. If the installation is felt hard, use cleaning solvent as lubricant.



1. Soapy water

Fig. 20-2-4

- When installing the glass-and-weatherstrip assembly to the window panel (body), previously fit a cord into the weatherstrip's body flange channel.
- Start the installation from the central bottom portion of the glass.
- Position the glass-and-weatherstrip assembly in the window panel (body) opening with a helper applying pressure by palm from the outside. Then, pull the weatherstrip over the flange with the cord to install the assembly into position.

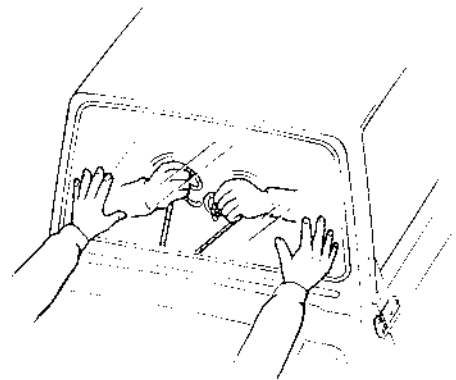


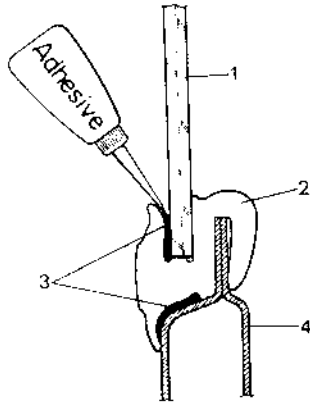
Fig. 20-2-5

- To settle the glass in place, tap it by palm from the outside.
- 6) As for the bonding agent, use urethan-based bonding agent having the strength as shown below:

Separating Strength	At least 6 kg/1/2 in wide
Shearing Strength	At least 10 kg/cm <sup>2</sup>

7) Fill bonding agent completely between the glass and the weatherstrip and also between the window panel (body) and the weatherstrip.

To confirm this condition, bonding agent should be oozed out of position.



1. Windshield glass
2. Windshield weatherstrip
3. Adhesive
4. Window panel (body)

*Fig. 20-2-6*

**IMPORTANT:**

- Bonding agent should be of the type which conforms to the material of the weatherstrip, having the above-mentioned strength. Also it must not affect the painted surface, weather strip or glass.
- Until when the bonding agent is so completely dried that its strength can be obtained sufficiently, the relevant vehicle should not be driven. As for the drying time, follow the direction suggested by the manufacturer of the relevant bonding agent.

8) Oozed bonding agent should be wiped and cleaned with solvent completely.



## 20-3. BACK DOOR (APPLICABLE TO HARD TOP VEHICLE)

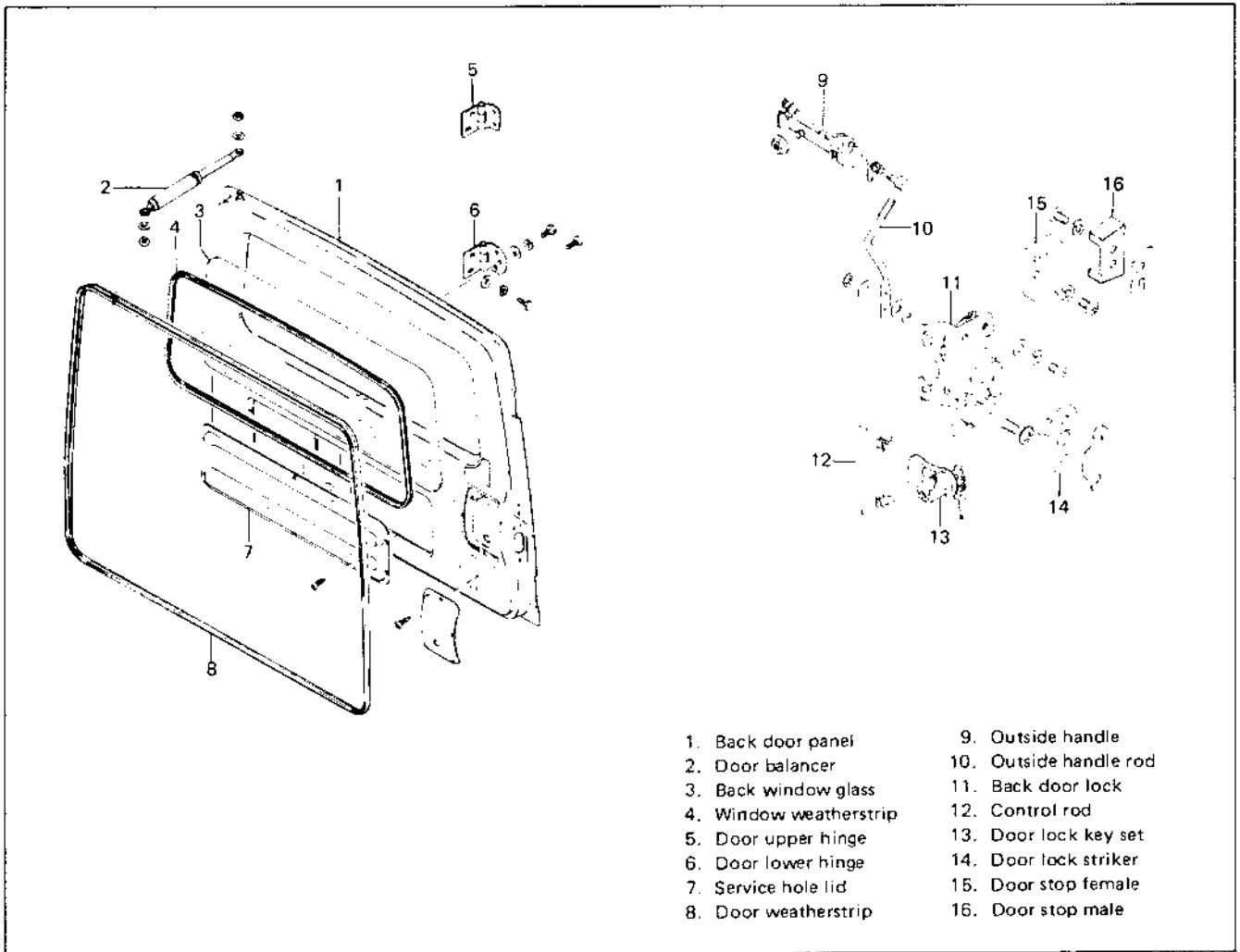


Fig. 20-3-1

### DOOR LOCK AND STRICKER ADJUSTMENT

#### Door Outside Open Rod

When installing open rod ② onto outside open handle ①, adjust clearances "A" to 0 – 2 mm (0 – 0.079 in) and "B" to 2 mm (0.079 in) as shown in Fig. 20-3-2 by turning adjusting joint ③.

#### NOTICE:

Don't push down push plate ④ when installing the rod.

After installing the open rod, give the outside handle a trial and check if its play felt then is appropriate.

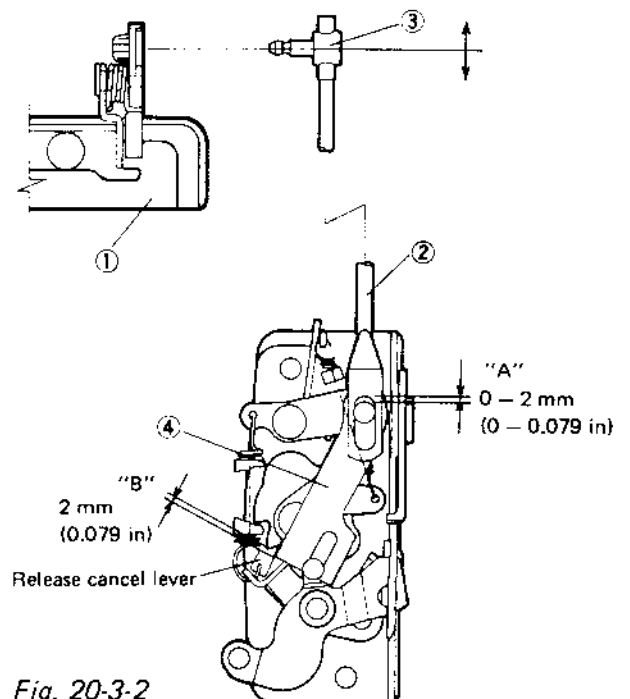


Fig. 20-3-2

## Door Lock Stricker

After reinstalling the door lock striker or door lock which was once removed, adjust dimension "C" in Fig. 20-3-3 to 1.0 mm (0.04 in) by moving the striker up and down.

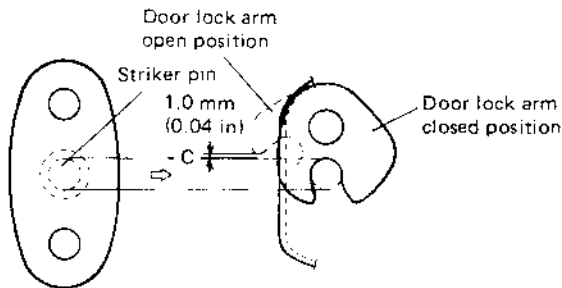


Fig. 20-3-3

To position the door lock striker correctly in the front and rear direction, adjust dimension "D" to 5.5 mm (0.22 in) as shown in Fig. 20-3-4 by increasing or decreasing spacers fitted in "E" position behind the striker.

After adjustment, check the difference in level between the door and body and adjust when there is a difference by moving the door lock striker to right or left.

**CAUTION:**  
Do not adjust the door lock.

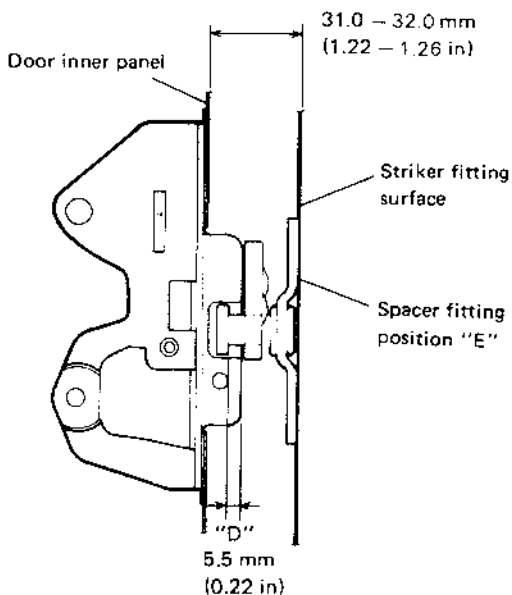


Fig. 20-3-4

## Handling of Back Door Balancer

### WARNING:

- Handle the balancer carefully. Do not scar or scratch the exposed surface of its piston rod, and never allow any paint or oil to stick to the surface.
- Do not disassemble the balancer because its cylinder is filled with high pressure gas.
- Do not put it into the fire.
- Do not store it where it gets hot.
- When discarding the removed back door balancer, envelop it, as illustrated, with a vinyl bag. Then, use a 2 to 3 mm (0.08 to 0.12 in) drill to make a hole, as shown, from above through the bag into the balancer and let gas out.

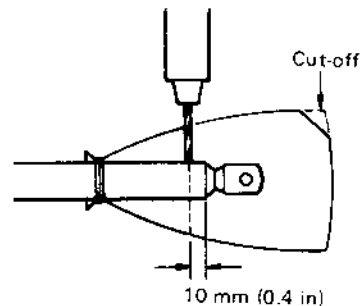
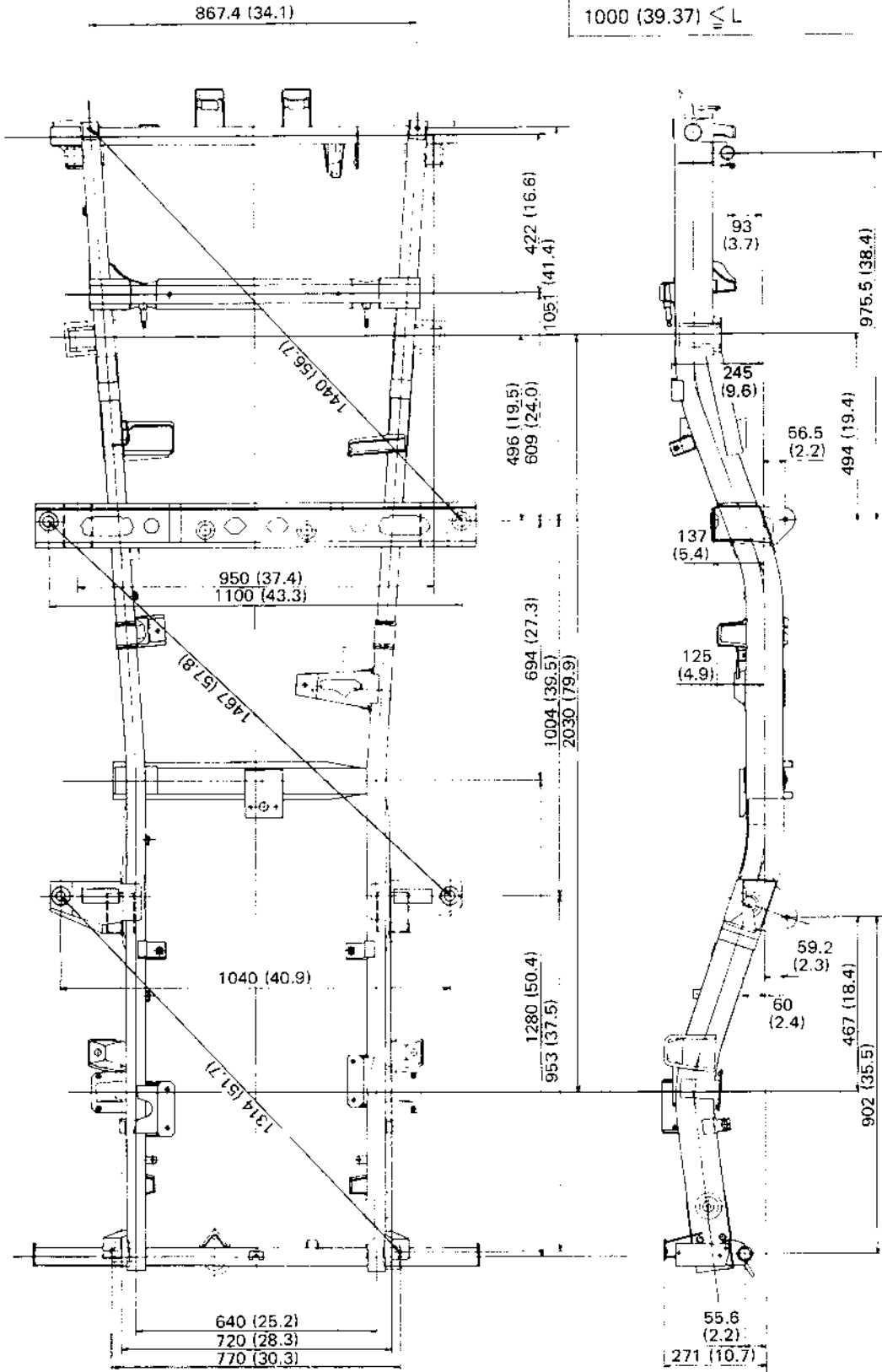


Fig. 20-3-5

# 20-4. CHASSIS DIMENSIONS

Unit: mm (in)

Dimension	Tolerance
$L < 100$ (3.94)	$\pm 2$ (0.079)
$100 \leq L < 1000$ (39.37)	$\pm 3$ (0.118)
$1000 \leq L$	$\pm 4$ (0.157)





## SECTION 21

# BODY ELECTRICAL EQUIPMENT

### CONTENTS

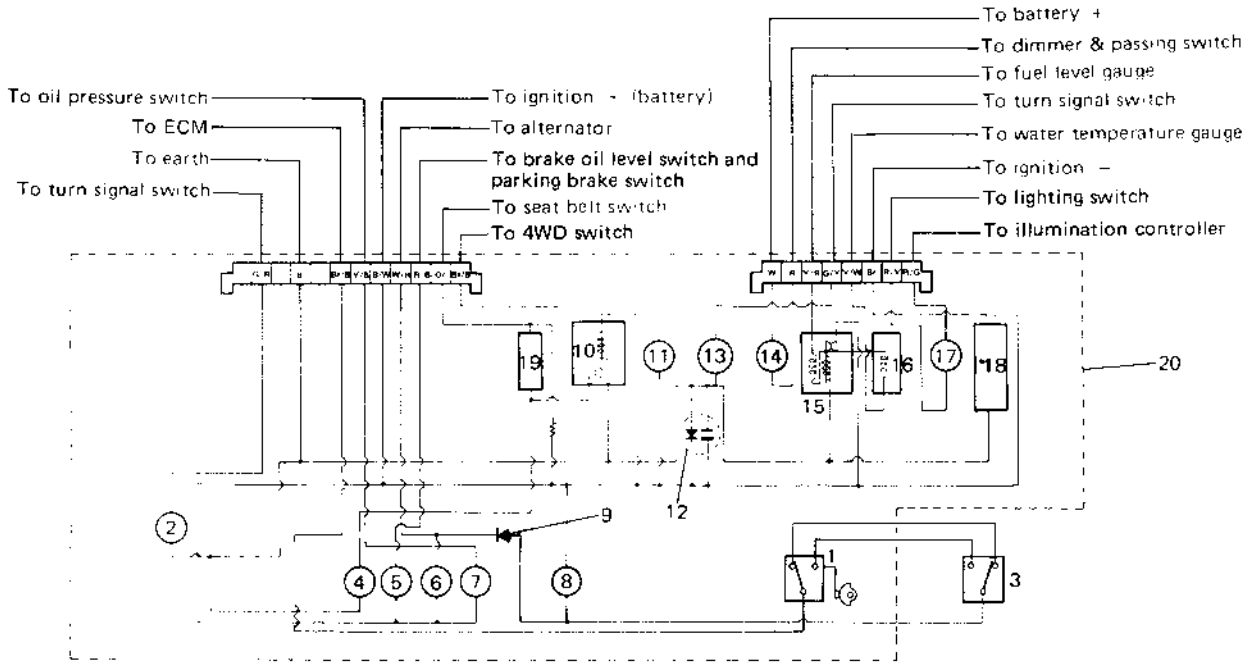
21-1.	COMBINATION METER . . . . .	21-2
21-2.	HEAD LIGHT . . . . .	21-4
21-3.	TURN SIGNAL LIGHT AND HAZARD WARNING LIGHT . . . . .	21-7
21-4.	WINDSHIELD WIPER MOTOR . . . . .	21-9
21-5.	WATER TEMPERATURE METER AND GAUGE . . . . .	21-11
21-6.	FUEL LEVEL METER AND GAUGE . . . . .	21-12
21-7.	BRAKE WARNING LAMP . . . . .	21-13
21-8.	OIL PRESSURE LAMP . . . . .	21-14
21-9.	4 WHEEL DRIVE LAMP . . . . .	21-15
21-10.	SEAT BELT WARNING LAMP/BUZZER . . . . .	21-15
21-11.	MAIN SWITCH KEY WARNING BUZZER . . . . .	21-16
21-12.	ILLUMINATION CONTROLLER . . . . .	21-16
21-13.	REAR DEFOGGER (OPTIONAL FOR HARD TOP MODEL) . . . . .	21-16
21-14.	FUSE BOX . . . . .	21-18
21-15.	WIRING HARNESS ROUTING . . . . .	21-19
21-16.	WIRING DIAGRAM . . . . .	21-22

## 21-1. COMBINATION METER

### COMBINATION METER CIRCUIT AND COMPONENTS

#### NOTICE:

Whether equipped with \* marked parts or not depends on vehicle specifications.



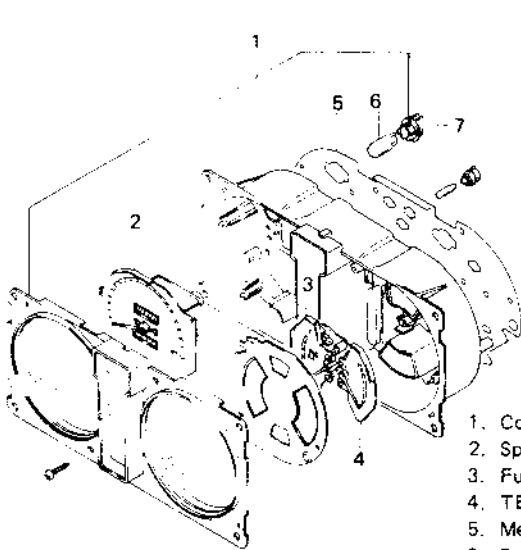
#### Wire color

G/R . . . . . Green/Red	Or . . . . . Orange
B . . . . . Black	Bl/B . . . . . Blue/Black
Br/B . . . . . Brown/Black	W . . . . . White
Y/B . . . . . Yellow/Black	Y/R . . . . . Yellow/Red
B/W . . . . . Black/White	G/Y . . . . . Green/Yellow
W/R . . . . . White/Red	Y/W . . . . . Yellow/White
R/B . . . . . Red/Black	R/Y . . . . . Red/Yellow
	R/G . . . . . Red/Green

- |  |                                 |
|--|---------------------------------|
| 1. 60,000 mile sensor switch                             | 11. 4WD light                   |
| 2. Turn signal pilot light (L)                           | 12. Noise suppressor            |
| 3. Cancel switch   | 13. Turn signal pilot light (R) |
| 4. Seat belt warning light                               | 14. Beam pilot light            |
| 5. Brake oil level warning light and parking brake light | 15. Fuel level meter            |
| 6. Charge light  | 16. Temp. meter                 |
| 7. Engine oil pressure light                             | 17. Illumination light          |
| 8. Sensor light  | 18. Tachometer                  |
| 9. Diode   | 19. Seat belt warning buzzer    |
| 10. Seat belt relay                                      | 20. Combination meter           |

[Combination meter without tachometer]

[Combination meter with tachometer]



1. Combination meter
2. Speedometer
3. Fuel meter
4. TEMP. meter
5. Meter print plate
6. Bulb
7. Socket
8. Tachometer

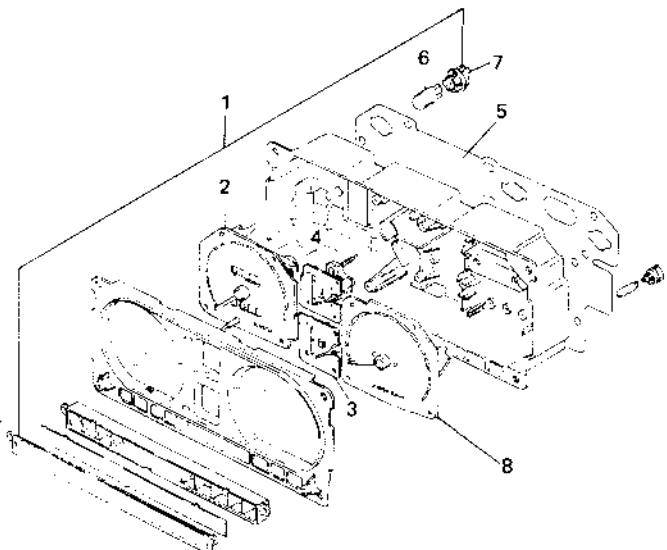
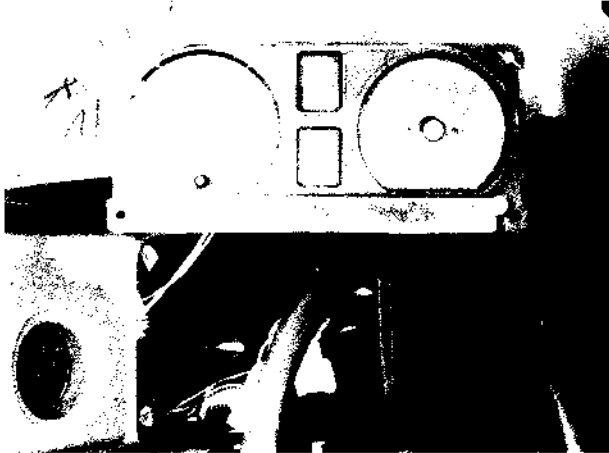


Fig. 21-1

## REMOVAL AND INSTALLATION

1. Disconnect battery negative cable.
2. Remove instrument lower panel.
3. Lower steering column.
4. Remove combination meter cover.
5. Disconnect speedometer cable and wire harness coupler.
6. Remove combination meter.



*Fig. 21-2*

7. To install combination meter, reverse above removal procedure.

## 21-2. HEAD LIGHT

### WIRING CIRCUIT

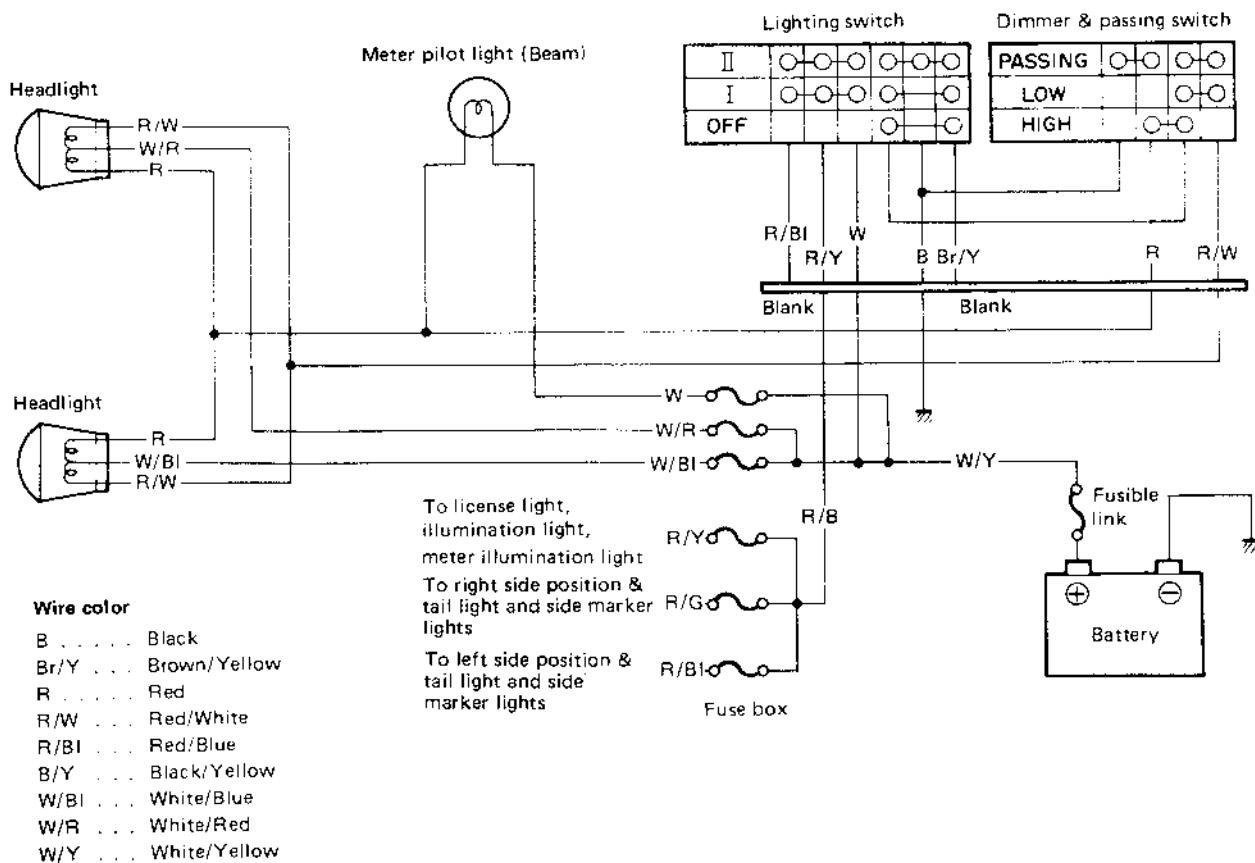


Fig. 21-3



## HEADLIGHT INSPECTION

1. Lighting (Low beam, High beam, Passing)
2. Mounting
3. Dirt and cracks on lenses
4. Main beam axis direction and brightness

## HEADLIGHT BEAM SETTING (STANDARD PROCEDURE)

Before setting the headlight beams, adjust air pressures of four tires to a specified value respectively. Move the vehicle up and down by hand to settle its attitude. Then move it over a flat surface. There are available a variety of headlight beams setting methods (e.g., the screen method using a focusing tester, etc.). However, the method described here does not use such tester.

### Beam alignment

Unless otherwise obligated by the local regulations, align the headlight beams according to the following procedure. Place a blank wall 7.6 m (25 ft) ahead of the headlight. Check to see if the hot spot (high intensity zone) of each main (low) beam axis falls as illustrated below. The beam alignment should be carried out with one driver (68 kg, 150 lb) aboard.

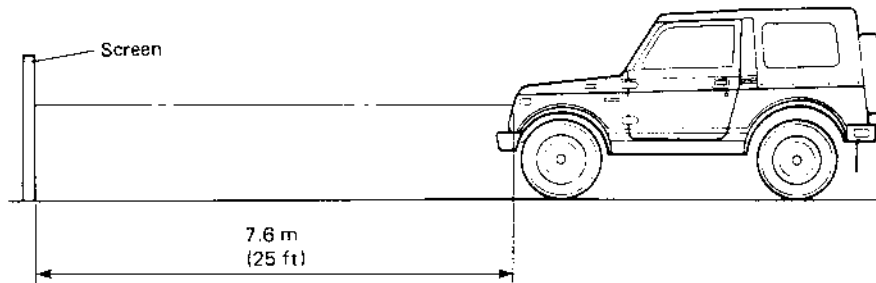
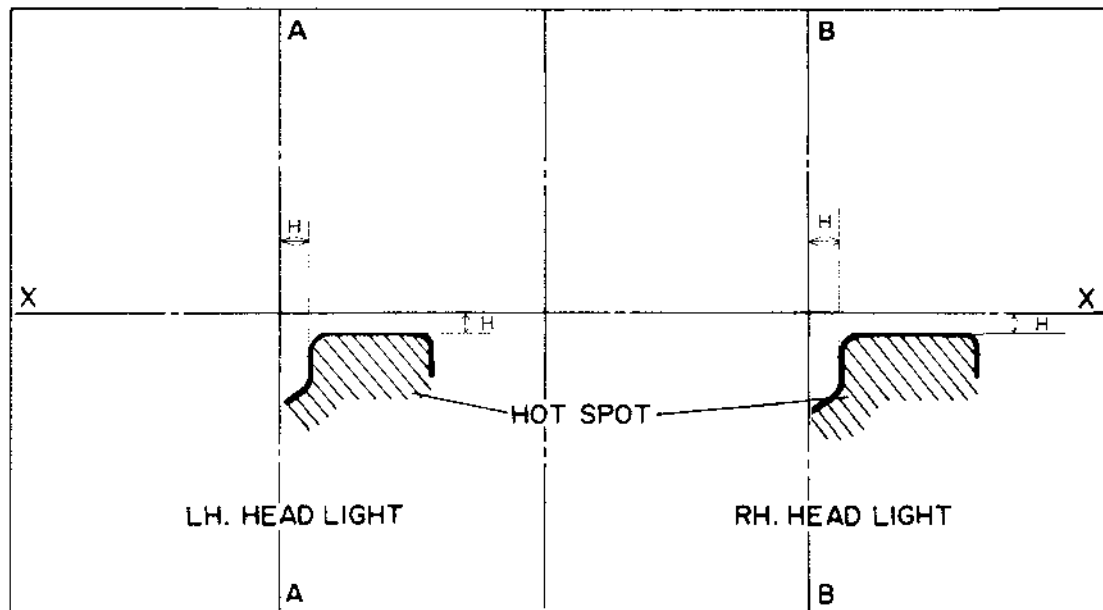


Fig. 21-4



- X - X : Horizontal center line of headlights      H : 25 mm (0.98 in.)  
A - A : Vertical center line of left headlight  
B - B : Vertical center line of right headlight

Fig. 21-5

## MAINTENANCE

### (1) Headlight adjustment

There are two screws ① and ② which can be used for adjustment. Use these screws to adjust the headlight position for the vertical and horizontal alignment of each beam.

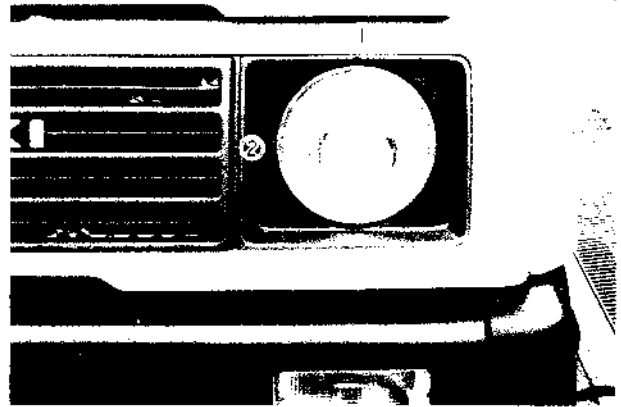
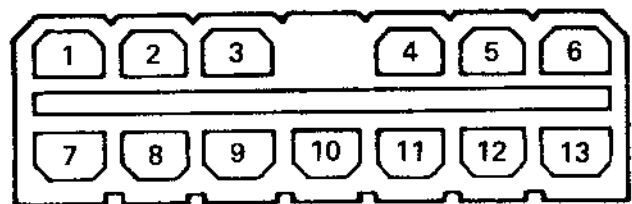


Fig. 21-6

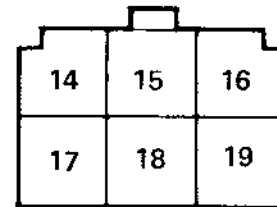
### (2) Head light dimmer switch

Using circuit tester, check each circuit for continuity by putting tester probe pins to the terminals shown in Fig. 21-7. With switch kept in LOW BEAM position, tester should indicate continuity between terminals ⑦ and ⑱. Similarly, there should be continuity between terminals ⑧ and ⑱ when in HIGH BEAM position.

#### Switch connector



- |                            |                  |
|----------------------------|------------------|
| 1. Green/Red (Green/Black) | 8. Red           |
| 2. Green/Yellow            | 9. Blue/Green    |
| 3. Green                   | 10. Brown/Yellow |
| 4. Yellow                  | 11. Red/Blue     |
| 5. White/Blue              | 12. Red/Yellow   |
| 6. Yellow/Blue             | 13. White        |
| 7. Red/White               |                  |



- |                  |                |
|------------------|----------------|
| 14. Yellow/White | 17. Blue/Black |
| 15. Blue         | 18. Black      |
| 16. Blue/Red     | 19. Blue/White |

Fig. 21-7

### Combination switch (Lighting switch circuit)

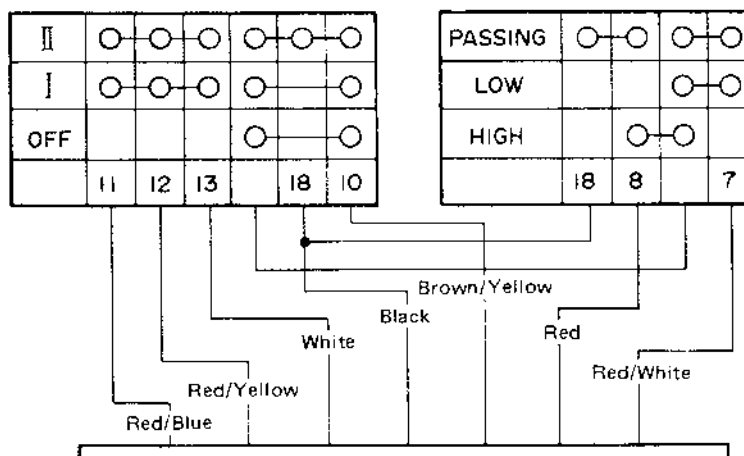
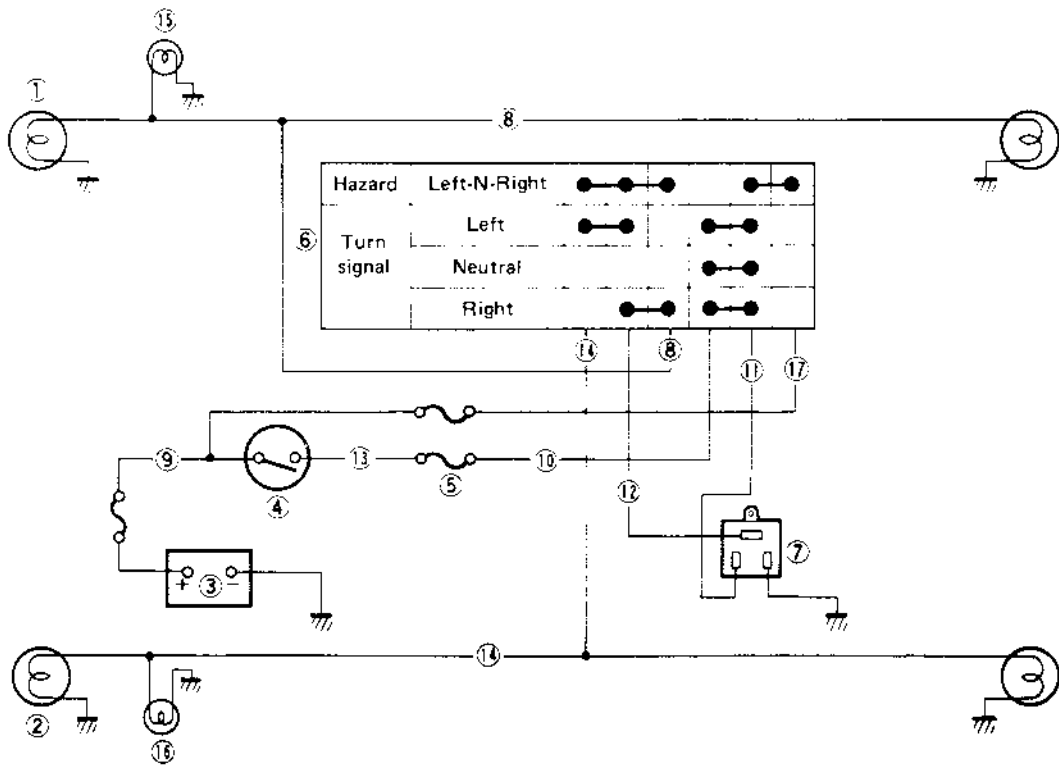


Fig. 21-8

## 21-3. TURN SIGNAL LIGHT AND HAZARD WARNING LIGHT

### CIRCUIT DESCRIPTION



- |  |                 |                               |
|--|-----------------|-------------------------------|
| 1. Right turn signal                     | 8. Green/Yellow | 15. Meter pilot light (Right) |
| 2. Left turn signal                      | 9. White/Yellow | 16. Meter pilot light (Left)  |
| 3. Battery                               | 10. Yellow      | 17. White/Green               |
| 4. Main switch                           | 11. Yellow/Blue |                               |
| 5. Fuse                                  | 12. Green       |                               |
| 6. Turn signal and hazard warning switch | 13. Black/Blue  |                               |
| 7. Turn signal and hazard warning relay  | 14. Green/Red   |                               |

Fig. 21-9

When hazard warning switch is "OFF", Yellow lead ⑩ is connected to Yellow/Blue lead ⑪.

When the hazard warning switch is "ON", White/Green lead ⑰ is connected to Yellow/Blue lead ⑪, and Green lead ⑫ to both Green/Yellow lead ⑧ and Green/Red lead ⑭.

When Turn-signal switch is "ON" for right turn, Green lead ⑫ is connected to Green/Yellow lead ⑧.

When Turn-signal switch is "ON" for left turn, Green lead ⑫ is connected to Green/Red lead ⑭.

## INSPECTION

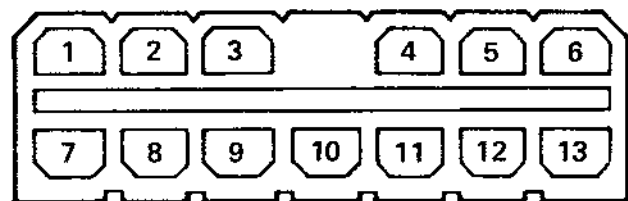
### 1) Trouble diagnosis

Symptom	Possible cause
1. Lights will not come on in either left or right group of light.	Fusible link is blown off.
2. Hazard light comes on but turn signal lights will not.	Open circuit (due to poor point contact) in turn signal dimmer switch.
3. No light comes on; or lights light up but do not flicker.	Defective relay unit.
4. Turn signal lights are satisfactory, but hazard light will not come on.	Open circuit in hazard warning switch.
5. Flickering frequency is erratic, or lights remain lit.	Light bulbs are defective or improperly grounded.
6. Turning on hazard warning switch lights up only one group of lights.	Defective contact in dimmer switch.

### 2) Turn signal switch

Using circuit tester, check for continuity between each pair of terminals by referring to the chart given below and figure at the right for each position of turn signal switch lever. Discontinuity means that contact points are burnt or otherwise defective in the switch. For example, switch is in sound condition if continuity is noted between terminals 2 and 3, with lever in right-turn position, and between terminals 1 and 3, with lever in left-turn position.

Switch connector



- |                            |                  |
|----------------------------|------------------|
| 1. Green/Red (Green/Black) | 8. Red           |
| 2. Green/Yellow            | 9. Blue/Green    |
| 3. Green                   | 10. Brown/Yellow |
| 4. Yellow                  | 11. Red/Blue     |
| 5. White/Blue              | 12. Red/Yellow   |
| 6. Yellow/Blue             | 13. White        |
| 7. Red/White               |                  |

Fig. 21-10

### 3) Hazard warning switch

Disconnect lead wire of the hazard warning switch at its coupler. Set switch to ON position and check for continuity with circuit tester between each of the following pairs of terminals; 2 and 3, 1 and 3, 5 and 6 among those shown in Fig. 21-10. The switch is in sound condition if continuity is noted between each pair.

### Turn signal & hazard warning switch

		1 (Green/Red or Green/Black)	3 (Green)	2 (Green/Yellow)	4 (Yellow)	6 (Yellow/Blue)	5 (White/Blue)
Hazard warning	Left-N-Right	●	●	●		●	●
	Left	●	●		●	●	
Turn signal	Neutral				●	●	
	Right		●	●	●	●	

## 21-4. WINDSHIELD WIPER MOTOR

### CIRCUIT DESCRIPTION

The circuit is designed so that, when the Wiper Switch is turned "OFF", the blade will automatically return to the horizontal position. In Fig. 21-11, when the Wiper Switch is turned "ON" while the Main Switch is "ON", current is supplied to the Wiper Motor from the Battery, the motor rotates and the blade moves. The gear mechanism which converts rotational movement of the motor into swinging movement of the blade has a cam on the final gear shaft. The cam switches the contacts of P0 and P2 every revolution. (At the blade stop position, the contact is switched from P2 to P1.)

Repeated contact making and breaking is independent of the wiper motor rotation. When the Wiper Switch is turned "OFF" while the blade is in a position other than the rest position, motor current path is changed (i.e. BI/W → BI → MOTOR). Therefore, the motor keeps rotating even though the wiper switch is turned "OFF", and the blade will return to the rest position.

When the blade returns to the rest position, the cam contact is changed from P2 to P1 and motor current is shunted. When supply to the motor is cut off, a counter electromotive force is generated in the armature. As a result of this counter electromotive force, current flows through the motor and shunt circuit and the motor stops and the wiper blade stays in the specified position.

### [INTERVAL WIPER RELAY CIRCUIT (OPTIONAL)]

When the wiper switch is set to the interval position with the ignition switch ON (the condenser is charged at this time), current from the battery flows through the yellow/blue wire, generates magnetic force in the coil in the relay and causes the switch in the relay to turn ON. Then current is transmitted in the sequence of yellow/blue, relay, wiper switch and blue and causes the wiper motor to rotate (meanwhile, the condenser discharges). By the time the wiper motor makes one rotation and the cam in the motor comes to the automatic stop position P1, the condenser in the relay has finished discharging (no magnetic force in the coil in the relay). Then the switch in the relay turns OFF and the wiper stops. They remain that way until the condenser is fully charged. As soon as the condenser begins discharging after being fully charged, magnetic force generated in the coil in the relay causes the switch to turn ON. As described above, interval operation of the wiper motor is controlled by charging and discharging of the condenser.

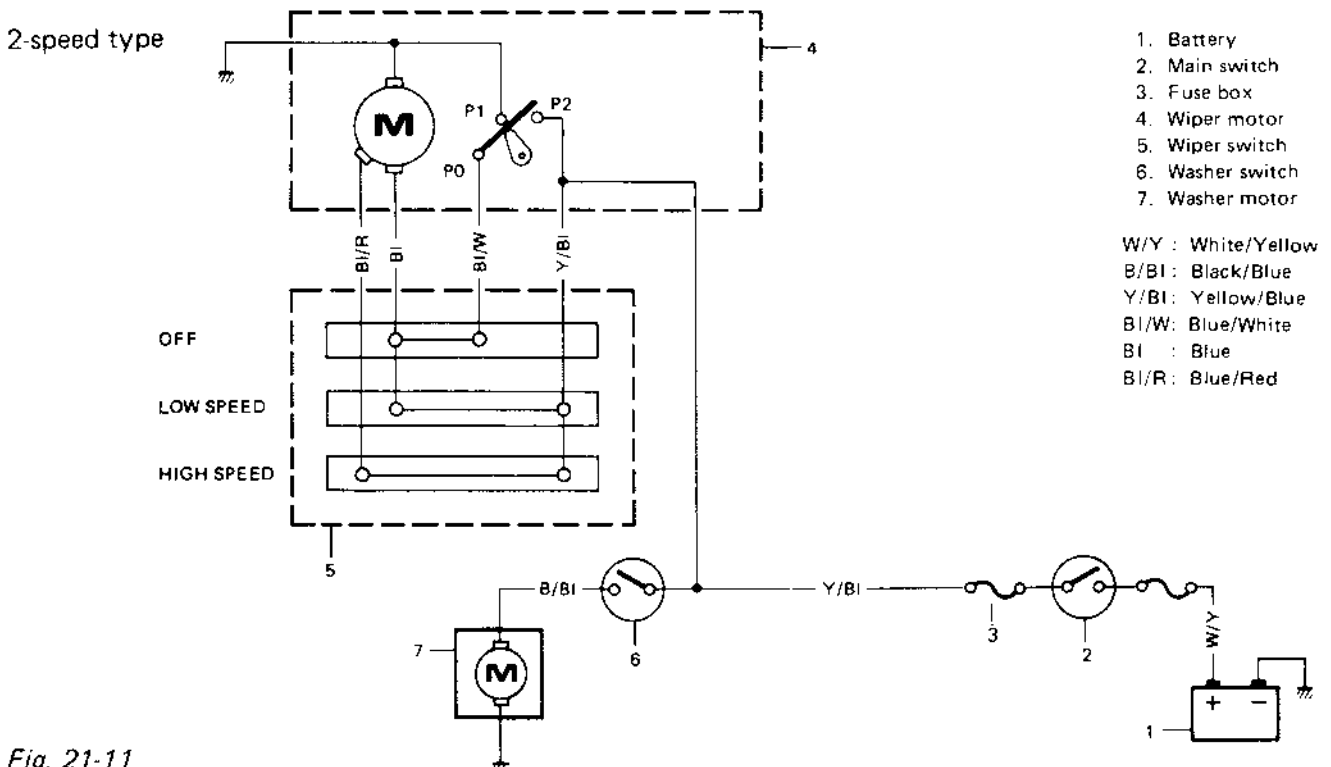


Fig. 21-11

3-speed type

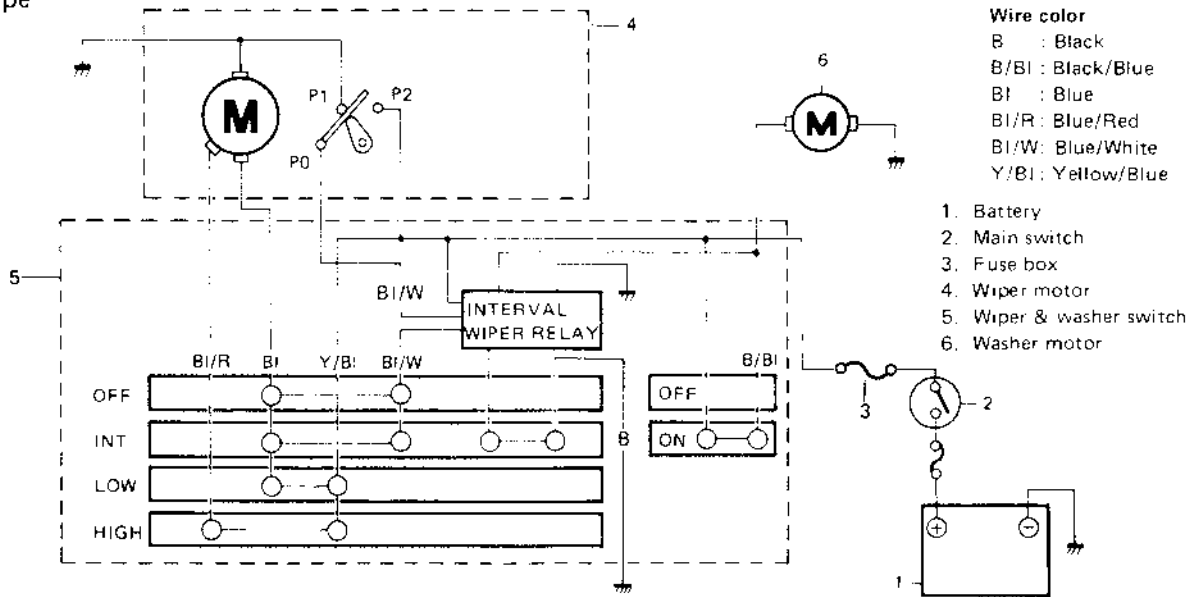


Fig. 21-12

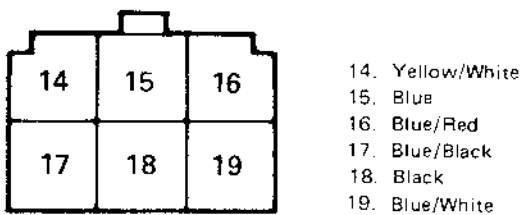
**MAINTENANCE**

1) Wiper trouble diagnosis

When wiper motor does not start even if Wiper Switch is turned "ON", check lead connections and coupler connections. Then, check the following.

- a) Fuse blown or mounted incorrectly.
- b) Wiper switch:  
To check wiper switch, remove couplers and check continuity between following terminals by using circuit tester.

Switch connector



2-speed type

	Yellow/white	Blue	Blue/red	Blue/white
High speed	●	●	●	
Low speed	●	●		
OFF		●		●

Wiper switch

3-speed type

	Yellow/white	Blue/white	Blue	Blue/red	To replay	Black
OFF		●	●			
Interval		●	●		●	●
Low speed	●		●			
High speed	●		●	●		

Wiper switch

c) Break in wiper motor armature or poor commutator brush contact:

To check these, check continuity between Blue lead and ground, and Blue/Red wire and ground respectively.

2) No-load run test

As shown in Fig. 21-13, using a 12V battery, connect positive battery terminal to Blue terminal and the negative terminal to motor. If motor rotates at 45 – 57 r/min, this is acceptable (for Low-speed check). For High-speed check, connect the positive terminal to Blue/Red terminal and negative terminal to motor. If motor rotates at 67 – 81 r/min, this is acceptable.

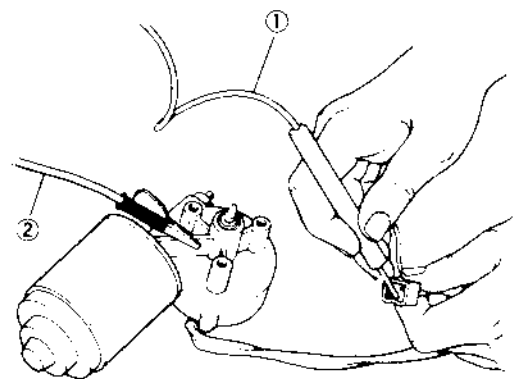


Fig. 21-13 Testing motor  
1. Positive terminal  
2. Negative terminal

### 3) Automatic stop action test

Connect yellow terminal of motor to positive ⊕ battery terminal, and put a jumper between Blue/White (Blue/Black) and Blue terminals to see if motor output shaft comes to a halt at a certain, not just any, angular position. That position corresponds to starting position of the blade. Using jumper, stop motor a number of times to make sure that motor stops at the same position each time.

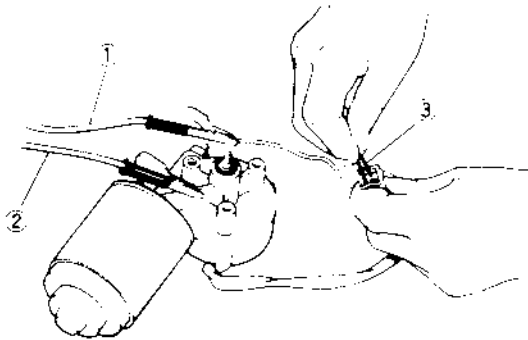


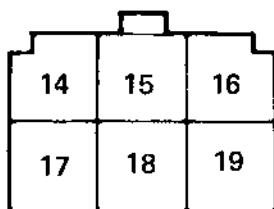
Fig. 21-14 Testing motor

1. Positive terminal
2. Negative terminal
3. Put a jumper between Blue/White (Blue/Black) and Blue

### 4) Internal wiper relay test

1. Disconnect wiper & washer switch coupler.
  2. Turn wiper switch to "INT" position.
  3. Connect positive battery terminal to Yellow/White coupler terminal and negative battery terminal to Black terminal.
- If an operating sound is heard, the relay is at work properly.

### Switch connector



14. Yellow/White
15. Blue
16. Blue/Red
17. Blue/Black
18. Black
19. Blue/White

Fig. 21-15

## 21-5. WATER TEMPERATURE METER AND GAUGE

The water temperature meter is located in the combination meter and its gauge unit on the inlet manifold.

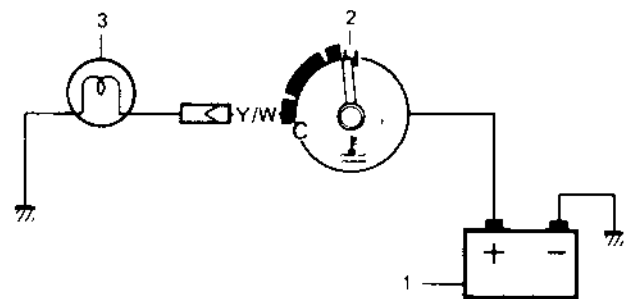
The gauge unit shows different resistance values depending on the coolant temperature. This causes a current flowing through the temperature meter coil to change, controlling the meter pointer. That is, when the coolant temperature is raised, the gauge unit resistance is decreased with more current flowing through the meter coil, raising the meter pointer upward from the "C" position.

### INSPECTION

[Water temperature meter]

1. Disconnect Y/W (Yellow/White) lead wire going to gauge unit installed to intake manifold.
2. Use a bulb (12V 3.4W) in position to ground above wires as illustrated.
3. Turn main switch ON, Confirm that the bulb is lighted and meter pointer fluctuates several seconds thereafter.

If meter is faulty, replace it.



1. Battery
  2. Water temperature meter
  3. Test lamp (12V, 3.4W)
- Y/W: Yellow/White

Fig. 21-16

[Gauge unit]

Warm up gauge unit. Thus make sure its resistance is decreased with increase of temperature. Temperature and resistance relationship can be plotted in a graph as shown below.

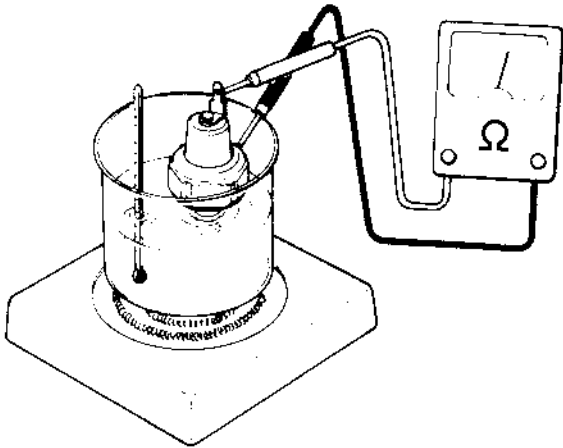


Fig. 21-17

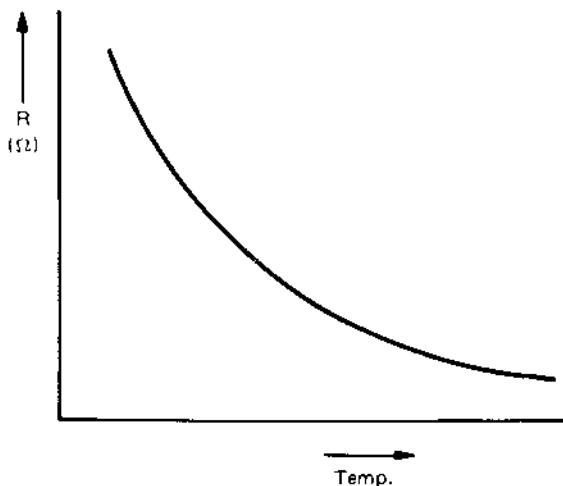


Fig. 21-18 Resistance-Temp. Relationship

Temperature	Resistance
50° C (122° F)	133.9 – 178.9 Ω
80° C (176° F)	47.5 – 56.8 Ω
100° C (212° F)	26.2 – 29.3 Ω

**NOTICE:**

Wind sealing tape on screw threads of gauge before installing gauge to intake manifold.

## 21-6. FUEL LEVEL METER AND GAUGE

The fuel level meter circuit consists of the fuel level meter installed inside the combination meter and the fuel level gauge installed to the fuel tank.

Current flowing through the meter coil is changed to control the meter pointer. That is, when fuel is full, the fuel level gauge unit resistance is decreased with more current flowing into the meter coil, causing the meter pointer to point at the "F" position.

### INSPECTION

[Fuel level meter]

1. Disconnect Y/R (Yellow/Red) lead wire going to gauge unit.
2. Use a bulb (12V 3.4W) in position to ground above lead wire as illustrated.
3. Turn ignition switch ON.

Make sure the bulb is lighted and meter pointer fluctuates several seconds thereafter. If meter is faulty, replace it.

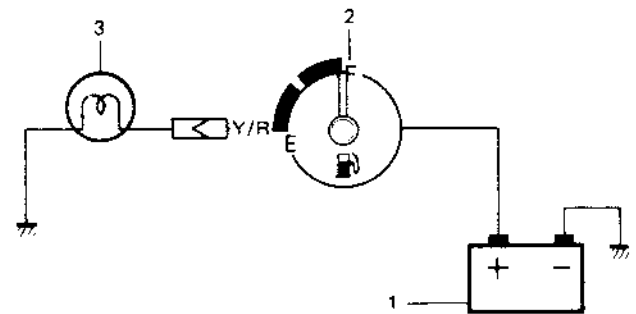


Fig. 21-19

1. Battery
  2. Fuel level meter
  3. Test lamp (12V, 3.4W)
- YR : Yellow/Red



[Gauge unit]

Use ohmmeter to confirm that level gauge unit changes in resistance with change of the float position. Float position-to-resistance relationship can be plotted in a graph as shown below.

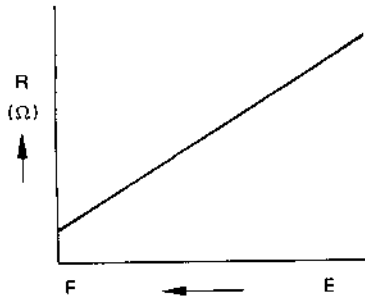
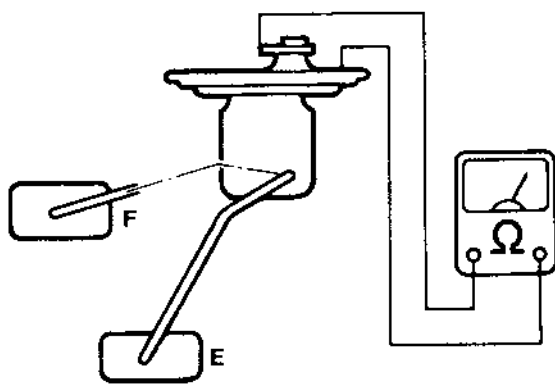


Fig. 21-20 Resistance-Fuel Level Relationship



F : Full  
E : Empty

Fig. 21-21

Position	Resistance
E	$110 \pm 7 \Omega$
F	$3 \pm 2 \Omega$
1/2	$32.5 \pm 4 \Omega$

## 21-7. BRAKE WARNING LAMP

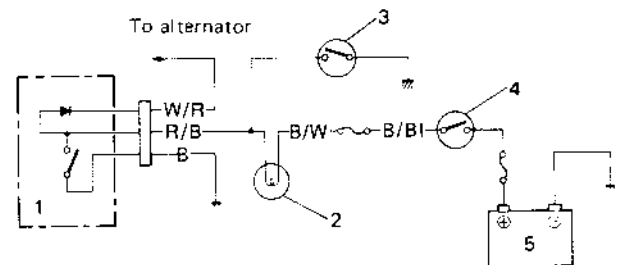
The brake warning lamp system consists of the brake fluid level switch installed to the master cylinder reservoir and the lamp inside the combination meter.

This circuit includes a parking brake switch which gives a warning for unreleased parking brake.

### OPERATION

When the engine is stopped, the warning lamp is lighted regardless of the brake fluid level position and parking brake operation, if the main switch is turned ON. This is because the point of the regulator incorporated in the alternator is closed so that the W/R lead wire is grounded.

After the engine is started (meaning the charging is started), release the parking brake. If the lamp goes OFF, the brake fluid level is proper.



W/R : White/Red  
R/B : Red/Black  
B : Black  
B/W : Black/White  
B/BI : Black/Blue

1. Fluid level switch  
2. Warning lamp  
3. Parking brake switch  
4. Main switch  
5. Battery

Fig. 21-22

## INSPECTION

[Brake fluid level switch]

Use ohmmeter to check switch for resistance and continuity.

If found defective, replace switch.

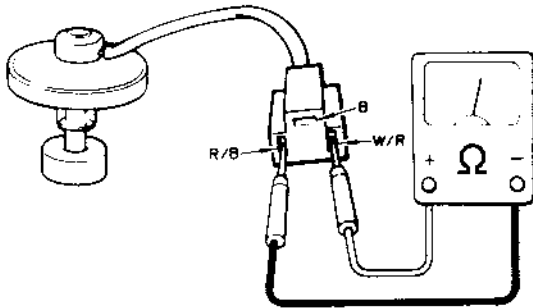


Fig. 21-23

W/R : White/Red  
 B : Black  
 R/B : Red/Black

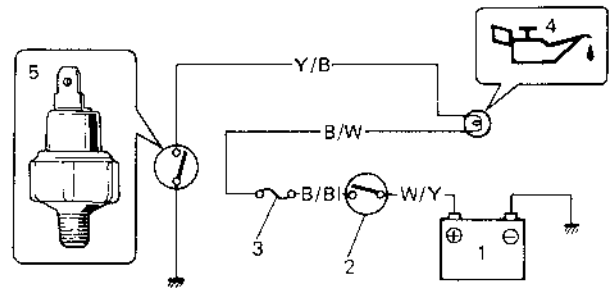
R/B – B Resistance	
OFF position (float up)	$\infty$
ON position (float down)	Several $\Omega$

R/B – W/R Continuity	
R/B to W/R	Continuity obtained
W/R to R/B	No continuity obtained

## 21-8. OIL PRESSURE LAMP

The oil pressure lamp circuit consists of the oil pressure switch installed to the cylinder block and the lamp (warning lamp) inside the combination meter.

The oil pressure switch so operates that it is switched OFF when oil pressure is produced by the started engine and then fed to switch.



1. Battery
  2. Main switch
  3. Fuse
  4. Oil pressure lamp
  5. Oil pressure switch
- B/B : Black/Blue  
 B/W : Black/White  
 Y/B : Yellow/Black  
 W/Y : White/Yellow

Fig. 21-24

## INSPECTION

[Oil pressure switch]

Use a ohmmeter to check the switch continuity.

During engine Running	No continuity obtained ( $\infty \Omega$ )
At Engine Stop	Continuity obtained ( $0 \Omega$ )

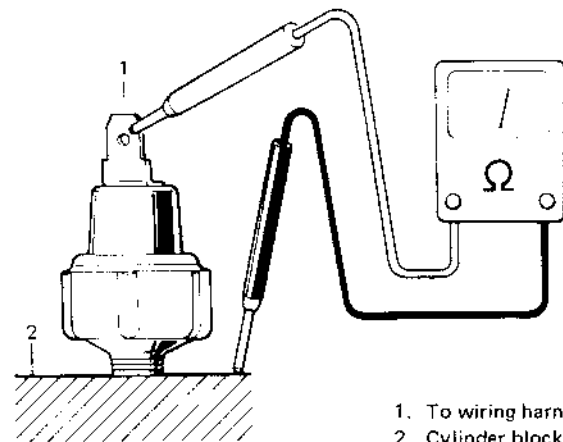


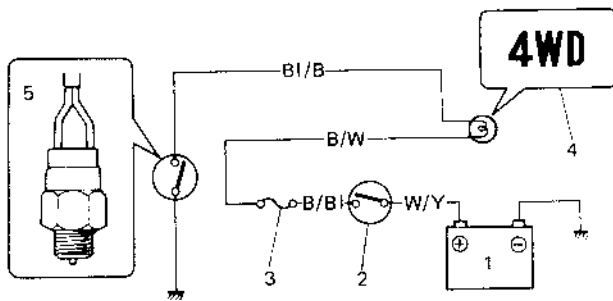
Fig. 21-25

1. To wiring harness
2. Cylinder block

## 21-9. 4 WHEEL DRIVE LAMP

The 4 wheel drive lamp circuit consists of the 4 wheel drive indicator lamp switch installed to the transfer and the lamp inside the combination meter.

The 4WD switch so operates that it is switched ON when transfer gear shift control lever is shifted to "4H" or "4L" position.



1. Battery
2. Main switch
3. Fuse
4. 4WD lamp
5. 4WD switch

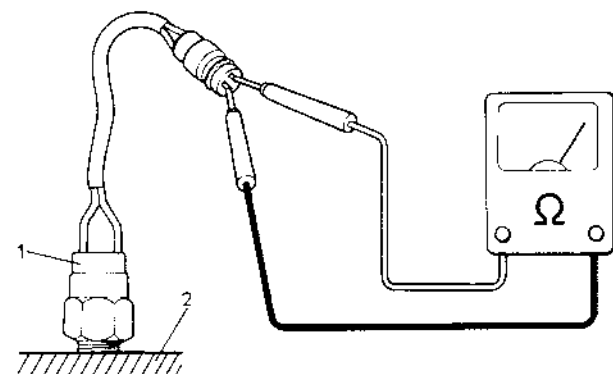
B/BI : Black/Blue  
 B/W : Black/White  
 BI/B : Blue/Black  
 W/Y : White/Yellow

Fig. 21-26

### INSPECTION [4WD switch]

Use a ohmmeter to check the switch continuity.

"4H" or "4L" position	Continuity obtained (0 Ω)
"2H" or "N" position	No continuity obtained (∞ Ω)

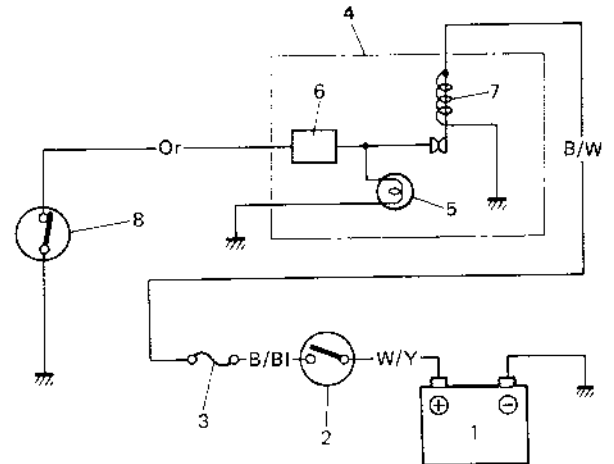


1. 4WD switch
2. Transfer

Fig. 21-27

## 21-10. SEAT BELT WARNING LAMP/BUZZER

The seat belt warning lamp/buzzer circuit is a system to light and sound the lamp and buzzer respectively for several seconds, urging the driver to wear his seat belt. After several seconds passed, the lamp goes OFF and the buzzer stops sounding whether the seat belt is worn or not.



1. Battery
2. Main switch
3. Fuse
4. Combination meter
5. Warning lamp
6. Warning buzzer
7. Bi-metal
8. Warning switch

W/Y : White/Yellow  
 B/BI : Black/Blue  
 B/W : Black/White  
 Or : Orange

Fig. 21-28

### INSPECTION

When the warning lamp/buzzer do not make lighting/sounding, use the above Circuit Diagram as reference to check the bulb, buzzer, wiring, etc.

## 21-11. MAIN SWITCH KEY WARNING BUZZER

The main switch key warning buzzer circuit is a system to sound the buzzer if the driver leaves the car with the main switch key inserted in place, urging him to take it out of place.

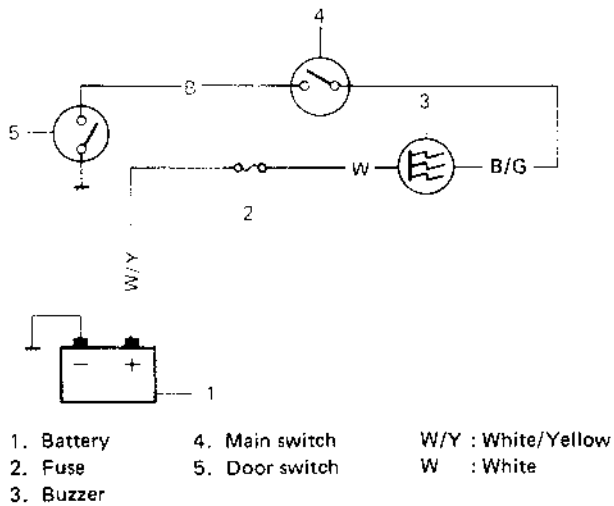


Fig. 21-29

### INSPECTION

If the main switch key warning buzzer does not sound, use the above Wiring Diagram as reference to check the buzzer.

## 21-12. ILLUMINATION CONTROLLER

### INSPECTION

Use a test lamp to wire as illustrated below.

Make sure that the illumination controller knob is turned rightwise to brighten the test lamp, leftwise to darken it.

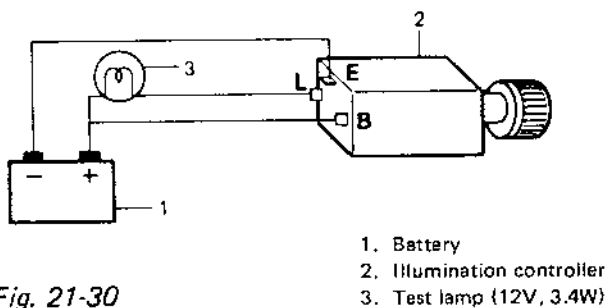
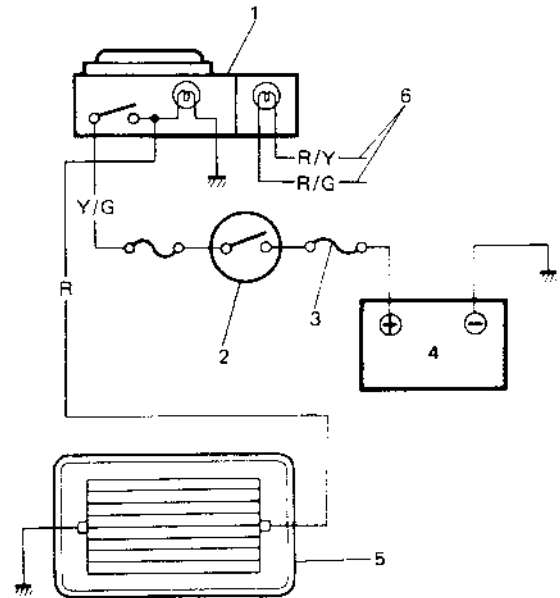


Fig. 21-30

## 21-13. REAR DEFOGGER (OPTIONAL FOR HARD TOP MODEL)

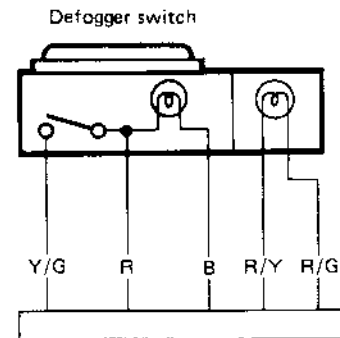
The Defogger circuit for the rear window glass heating wires is as follows:



1. Defogger switch                      Y/G : Yellow/Green  
 2. Main switch                              B : Black  
 3. Fusible link                              R : Red  
 4. Battery                                      R/Y : Red/Yellow  
 5. Rear window glass with embedded heating wire                      R/G : Red/Green  
 6. To illumination controller

Fig. 21-31

To check function of Defogger Switch, check continuity between Yellow/Green wire and Red wire when Defogger Switch is "ON"



- Y/G : Yellow/Green  
 R : Red  
 B : Black  
 R/Y : Red/Yellow  
 R/G : Red/Green

Fig. 21-32

## DEFOGGER WIRE

### NOTICE:

- When cleaning the rear window glass, use a dry cloth to wipe it along the wire direction.
- When cleaning the glass, do not use detergent or abrasive-containing glass cleaner.
- When measuring wire voltage, use a tester with the negative probe wrapped with a tin foil which should be held down on the wire by finger pressure.

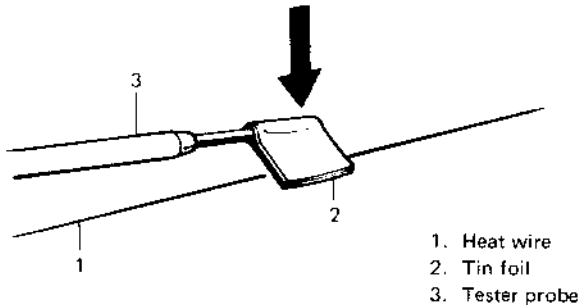


Fig. 21-33

### 1) Checking wire damage

- Turn the main switch ON.
- Turn the defogger switch ON.
- Use a voltmeter to check the voltage at the center of each heat wire, as illustrated.

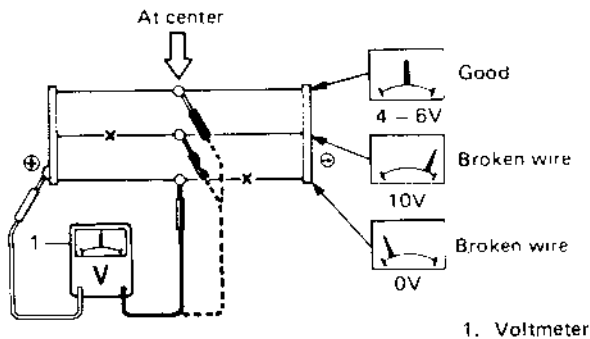


Fig. 21-34

Voltage	Criteria
Approx. 5V	Good (No break in wire)
Approx. 10V or 0V	Broken wire

If the obtained voltage is 10V, the wire must be damaged between its center and positive end. If the voltage is zero, the wire must be damaged between its center and earth.

### 2) Checking wire for damaged place

- Set the voltmeter positive (+) lead to the heat wire positive terminal end.

- Set the voltmeter negative (-) lead with a foil strip to the heat wire positive terminal end to then move it along the wire to the negative terminal end.
- The place which causes the voltmeter to fluctuate from zero to several volts is a damaged place.

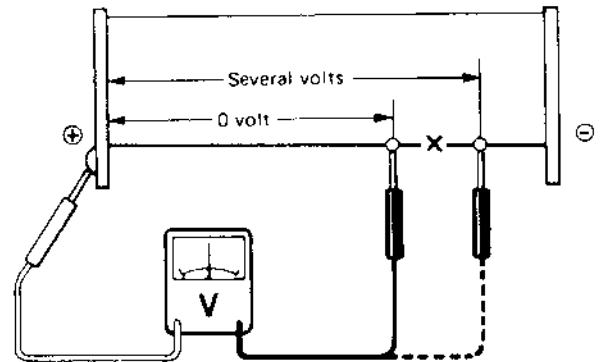


Fig. 21-35

### NOTICE:

If the heat wire is free from damage, the voltmeter should point 12V at the heat wire positive terminal end with its indication gradually decreased toward zero to thus equal 0V at the other terminal (earth) end.

### REPAIR

[Defogger circuit]

- Use white gasoline for cleaning.
- Apply a masking tape at both the upper and lower sides of a heat wire to be repaired.

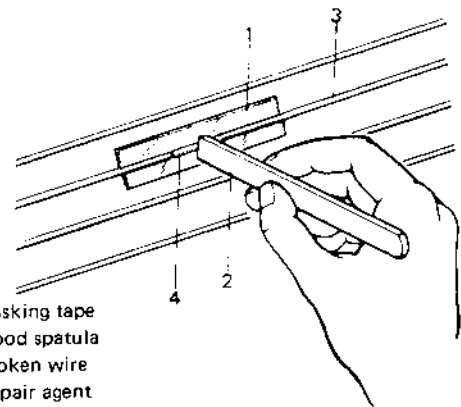
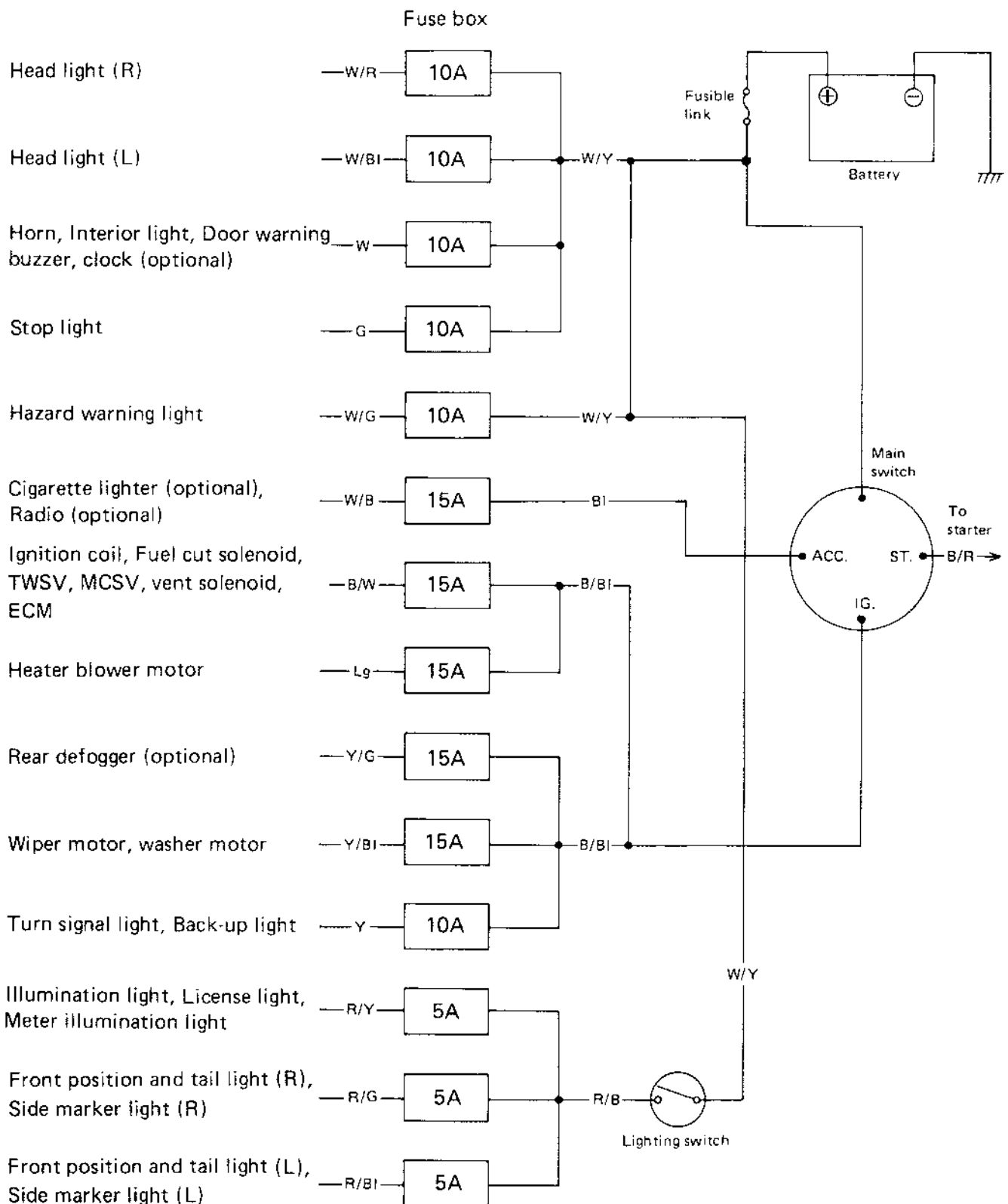


Fig. 21-36

- Apply commercially-available repair agent with a fine-tip brush.
- Two to three minutes later, remove the masking tapes previously applied.
- Leave the repaired heat wire as it is for at least 24 hours before operating the defogger again.

## 21-14. FUSE BOX

The fuses in the fuse box is wired as follows.

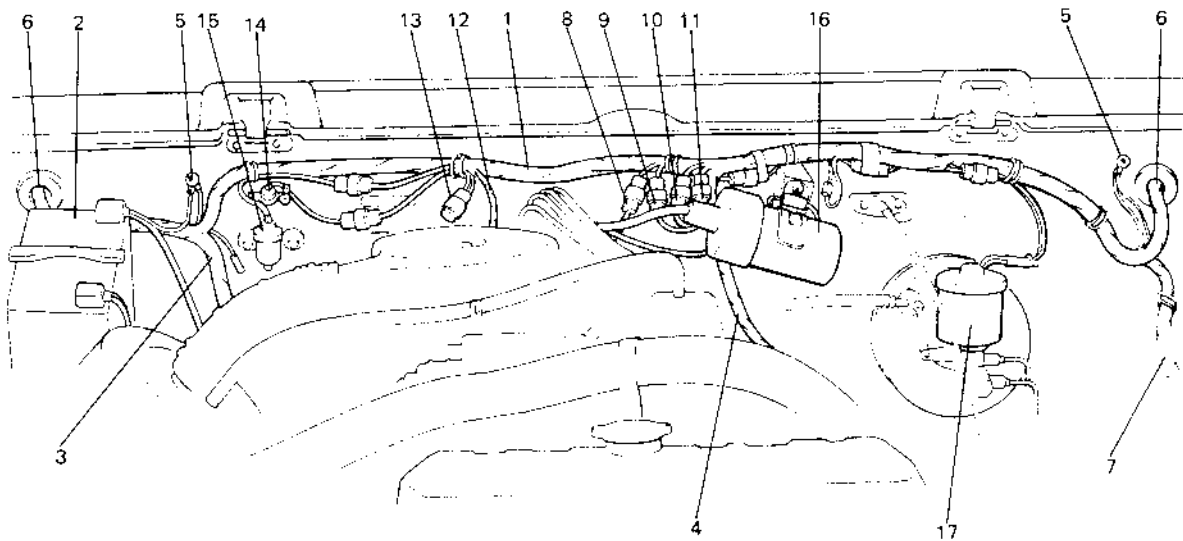


## 21-15. WIRING HARNESS ROUTING

When reinstalling wire harness, be careful for the following.

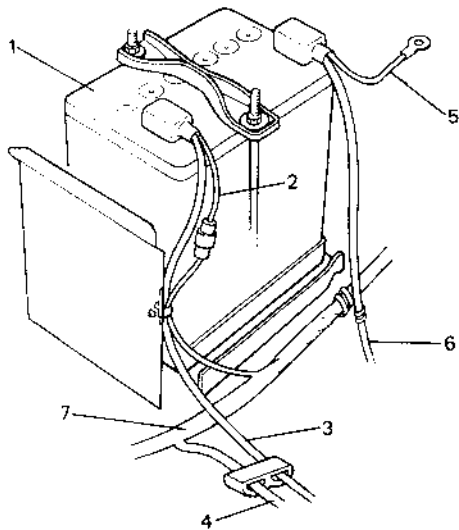
- When doing wiring harness related work, make always sure to disconnect battery negative cable from battery.
- Clamp wire harness securely at prescribed positions.
- Try to route wire harness so as to avoid contact with other parts as much as possible. Use special care not to let it contact sharp edges of body or other parts.
- Connect connectors securely.

### Engine Room Wiring

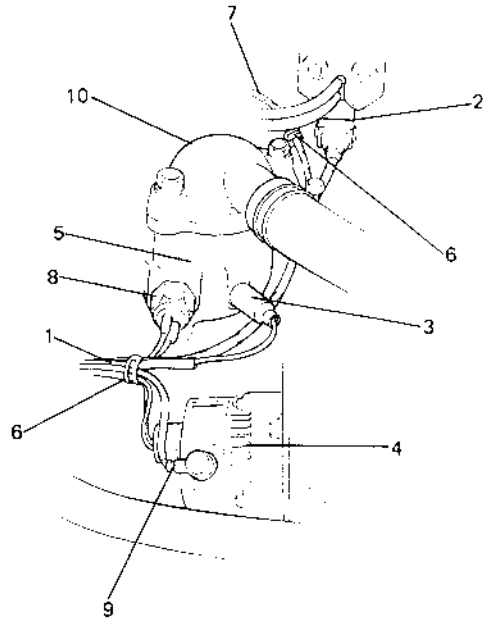


- |   |                                |
|---|--------------------------------|
| 1. Wire harness No. 2   | 12. To TWSV                    |
| 2. Battery  | 13. Duty check coupler         |
| 3. To starter, alternator, head light, small light, horn and etc. | 14. Thermal engine room switch |
| 4. To license light, stop/tail light, 4WD switch                  | 15. HAC                        |
| 5. Earth  | 16. Ignition coil              |
| 6. To wiring harness No. 1  | 17. Brake fluid reservoir      |
| 7. To head light, small light, etc.                               |                                |
| 8. To distributor   |                                |
| 9. To ignition coil   |                                |
| 10. To back up light switch                                       |                                |
| 11. To fifth switch   |                                |

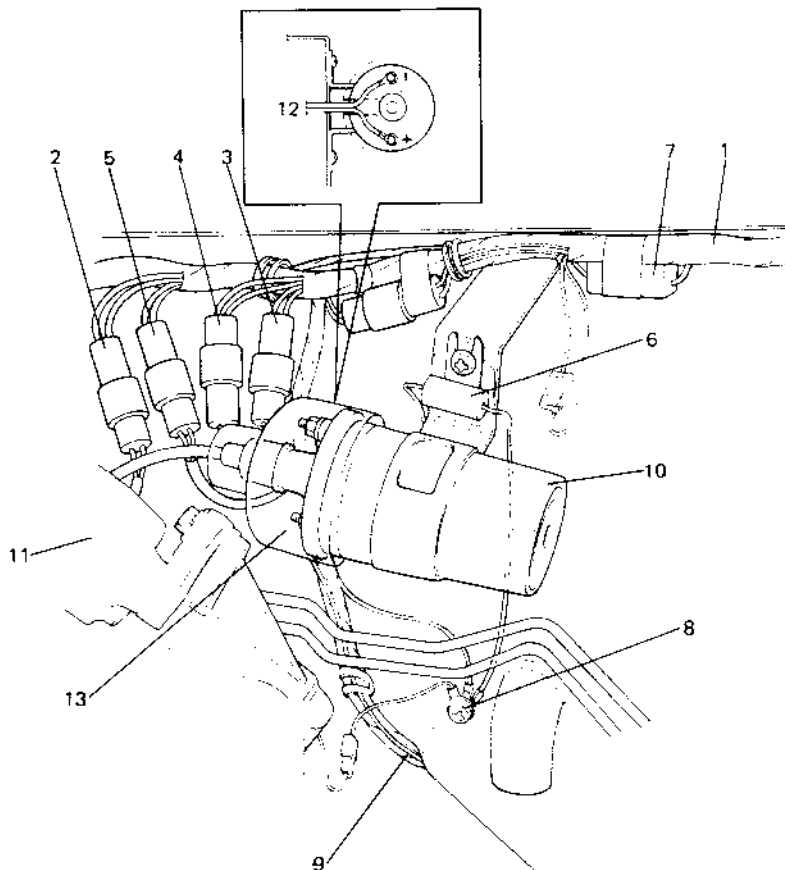
Fig. 21-37



1. Battery
2. Fusible link
3. To starter
4. To starter, alternator, etc
5. Earth
6. Earth (To starter mounting bolt)
7. Wiring harness No. 2



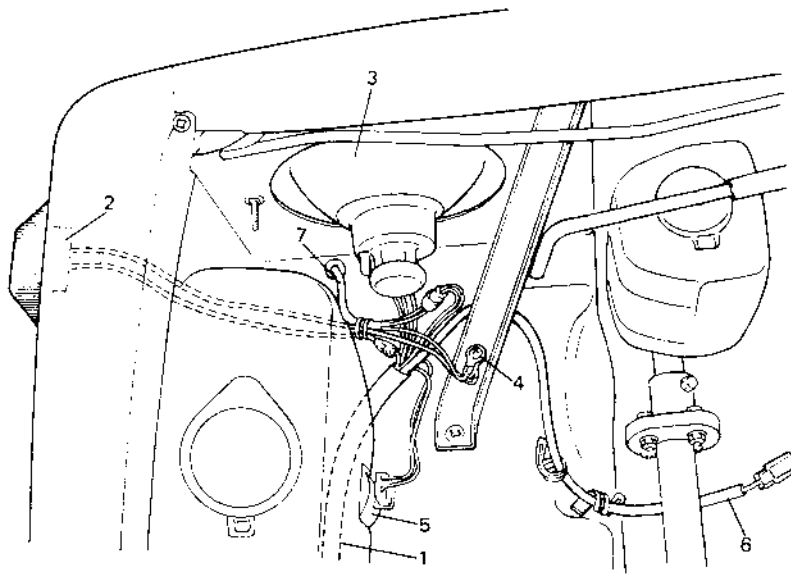
1. From wire harness No. 2
2. TWSV (Three way solenoid valve)
3. Water temperature gauge
4. Alternator
5. Intake manifold
6. Clamp
7. To VSV
8. Thermal switch
9. Mount this terminal horizontally as shown
10. Thermostat cap



1. Wire harness No. 2
2. To distributor
3. To fifth switch
4. To back up light switch
5. To ignition coil
6. Condenser
7. Noise suppressor filter (Clamp it toward engine room so as to prevent it from contacting dash panel edge.)
8. Earth
9. To license light, stop/tail light, 4WD switch
10. Ignition coil
11. Distributor
12. To wire harness No. 2
13. Ignition coil cap

Fig. 21-38

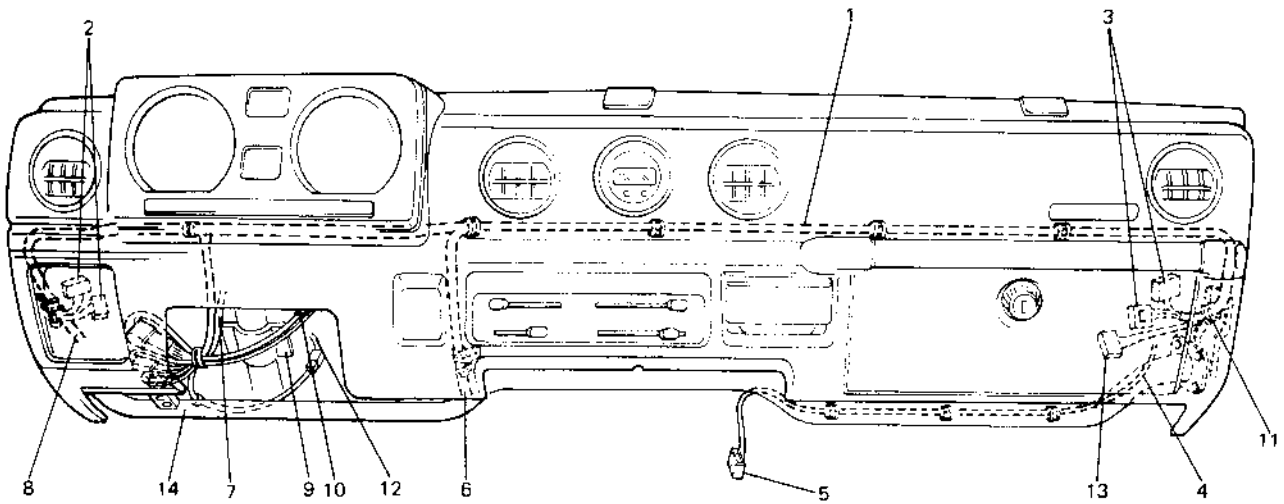




1. Wire harness No. 2
2. Side marker light
3. Head light
4. Earth
5. Washer motor
6. To oil pressure gauge
7. To combination light

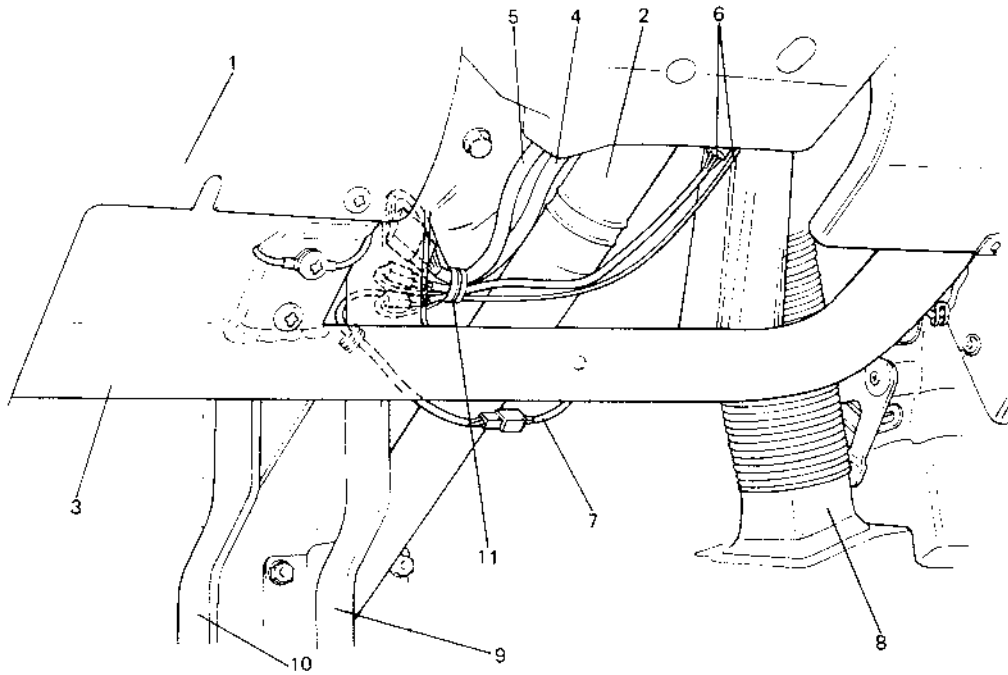
Fig. 21-39

### Instrument Panel Wiring



- |   |  |
|---|--|
| 1. Wire harness No. 1   | 8. To fuse box   |
| 2. To wire harness No. 2  | 9. Steering column bracket   |
| 3. To wire harness No. 2  | 10. To ignition switch   |
| 4. To speaker (optional)  | 11. Clamp wire harness, using care not to press them against instrument panel. |
| 5. To radio (optional)  | 12. To clutch switch   |
| 6. To heater blower motor, cigarette lighter and radio (optional) | 13. To ECM   |
| 7. To combination switch  | 14. Steering column holder   |

Fig. 21-40



- |   |   |
|---|---|
| <ul style="list-style-type: none"> <li>1. Instrument panel</li> <li>2. Steering column</li> <li>3. Steering column holder</li> <li>4. Wiring harness No. 1</li> <li>5. To combination switch</li> <li>6. To ignition switch</li> <li>7. To clutch switch</li> </ul> | <ul style="list-style-type: none"> <li>8. Defroster hose</li> <li>9. Brake pedal</li> <li>10. Clutch pedal</li> <li>11. Clamp lead wires of ignition switch and combination switch, using care not to allow lead wires to contact the edge of steering column bracket.</li> </ul> |
|---|---|

*Fig. 21-41*

## 21-16. WIRING DIAGRAM

Wiring diagrams are attached at the end of this manual.

# SECTION 22

## SERVICE DATA

### CONTENTS

22-1. SPECIFICATIONS .....	22-1
22-2. SERVICE DATA .....	22-4

### 22-1. SPECIFICATIONS

	Models	Convertible/Hard Top
<b>ENGINE</b>		
Type	Four-stroke cycle, water cooled, OHC	
Number of cylinders	4	
Lubrication system	Wet sump	
Bore	74.0 mm (2.91 in.)	
Stroke	77.0 mm (3.03 in.)	
Piston displacement	1,324 cm <sup>3</sup> (1,324 cc, 80.8 cu. in.)	
Compression ratio	8.9 : 1	
Carburetor	HITACHI two-barrel down draft	
Air cleaner	Polyester fiber element (Dry type)	
<b>ELECTRICAL</b>		
Ignition timing	10° B.T.D.C. at 800 r/min (rpm)	
Standard spark plug	NGK BPR-5ES or NIPPON DENSO W16EXR-U	
Starter	Magnetic shift type	
Generator	Alternator	
Battery	12V, 137 kC (38 Ah)/5HR	
Headlight	12V, 60/50W	
Turn signal light	12V, 32 cp	
Clearance light	12V, 4 cp	

Item		Models	Convertible/Hard Top
Tail/Brake light			12V, 3/32 cp
Side marker light			12V, 3.8W
License plate light			12V, 4 cp
Back-up light			12V 32 cp
Interior light			12V, 5W
Meter pilot light			12V, 3.4W
Main fuse			0.5 mm <sup>2</sup> (fusible link)
Fuse box			10/10/10/10/10/15/15/15/15/15/10/5/5/5A
<b>POWER TRANSMISSION</b>			
Clutch type			Dry, single disc
Transmission type			5-forward all synchromesh, 1 reverse
Final reduction ratio			3.727
Gear ratios	low		3.652
	2nd		1.947
	3rd		1.423
	4th		1.000
	5th		0.795
	reverse		3.466
Transfer gear ratios	low range		2.268
	high range		1.409
Overall reduction ratios:			
Low range	low		30.869
	2nd		16.457
	3rd		12.028
	4th		8.452
	5th		6.720
	reverse		29.297
High range	low		19.177
	2nd		10.224
	3rd		7.472
	4th		5.251
	5th		4.174
	reverse		18.201

Item	Models	Convertible/Hard Top
<b>WHEEL AND SUSPENSION</b>		
Tire size: front and rear		P205/70 R15
Tire pressure	front	140 kPa (1.40 kg/cm <sup>2</sup> , 20 psi)
	rear	140 kPa (1.40 kg/cm <sup>2</sup> , 20 psi)-unladen 180 kPa (1.80 kg/cm <sup>2</sup> , 26 psi)-laden
Suspension type	front	Leaf spring
	rear	Leaf spring
<b>STEERING</b>		
Turning radius		5.1 m (16.7 ft)
Steering gear box		Ball nut type
Toe-in		2 – 6 mm (0.08 – 0.24 in.)
Camber angle		1° 00'
Caster angle		3° 30'
King pin angle		9° 00'
<b>BRAKE SYSTEM</b>		
Type		4-wheel, hydraulic
Wheel brake	front	Disc brake (floating caliper type)
	rear	Drum brake (leading and trailing)
Parking brake		Mechanical actuated on rear wheels
<b>CAPACITIES</b>		
Cooling solution		5.0 ℓ (10.6/8.8 US/Imp pt)
Fuel tank		40ℓ (10.6/8.8 US/Imp gal)
Engine oil		3.5 ℓ (7.4/6.2 US/Imp pt)
Transmission oil		1.3 ℓ (2.7/2.3 US/Imp pt)
Differential gear box oil	front	2.0 ℓ (4.2/3.5 US/Imp pt)
	rear	1.5 ℓ (3.2/2.6 US/Imp pt)
Transfer gear box oil		0.8 ℓ (1.7/1.4 US/Imp pt)

## 22-2. SERVICE DATA

### ENGINE

Item		Standard		Service Limit		
Compression pressure		14.0 kg/cm <sup>2</sup> (199.0 psi)/400 r/min (rpm)		12.0 kg/cm <sup>2</sup> (170.0 psi)/400 r/min (rpm)		
	Difference between cylinders	_____		1.0 kg/cm <sup>2</sup> (14.2 psi)/400 r/min (rpm)		
Valve lash (clearance)	Cold (When coolant temperature is 15 ~ 25°C or 59 ~ 77°F)	Inlet	0.13 ~ 0.17 mm (0.0051 ~ 0.0067 in.)	_____		
		Exhaust	0.16 ~ 0.20 mm (0.0063 ~ 0.0079 in.)	_____		
	Hot (When coolant temperature is 60 ~ 68°C or 140 ~ 154°F)	Inlet	0.23 ~ 0.27 mm (0.009 ~ 0.011 in.)	_____		
		Exhaust	0.26 ~ 0.30 mm (0.0102 ~ 0.0118 in.)	_____		
Cylinder head	Flatness of gasketed surface		_____	0.05 mm (0.002 in.)		
	Flatness of manifold seat	Inlet	_____	0.1 mm (0.004 in.)		
		Exhaust	_____	0.1 mm (0.004 in.)		
	Valve seat	Seating width	Inlet	1.3 ~ 1.5 mm (0.0512 ~ 0.0590 in.)	_____	
			Exhaust	1.3 ~ 1.5 mm (0.0512 ~ 0.0590 in.)	_____	
	Seating angle		45°		_____	
Valve guide hole diameter (In & Ex) (over size)		12.030 ~ 12.048 mm (0.4736 ~ 0.4743 in.)		_____		
Valve, valve spring & cam shaft	Camshaft/Journal clearance		0.050 ~ 0.091 mm (0.0020 ~ 0.0036 in.)	0.15 mm (0.0059 in.)		
	Camshaft thrust clearance		_____	0.75 mm (0.0295 in.)		
	Cam height (Base circle + lift)	Inlet	37.500 mm (1.4763 in.)	37.400 mm (1.4724 in.)		
		Exhaust	37.500 mm (1.4763 in.)	37.400 mm (1.4724 in.)		
		Fuel pump cam	40.000 mm (1.5748 in.)	39.600 mm (1.5590 in.)		
	Camshaft runout		_____	0.10 mm (0.0039 in.)		
	Valve stem diameter	Inlet	6.965 ~ 6.980 mm (0.2742 ~ 0.2748 in.)	_____		
		Exhaust	6.950 ~ 6.965 mm (0.2737 ~ 0.2742 in.)	_____		
	Valve guide I.D.	Inlet	7.000 ~ 7.015 mm (0.2756 ~ 0.2761 in.)	_____		
		Exhaust	7.000 ~ 7.015 mm (0.2756 ~ 0.2761 in.)	_____		
	Valve guide-to-valve stem clearance	Inlet	0.020 ~ 0.050 mm (0.0008 ~ 0.0019 in.)	0.07 mm (0.0027 in.)		
		Exhaust	0.035 ~ 0.065 mm (0.0014 ~ 0.0025 in.)	0.09 mm (0.0035 in.)		
	Thickness of valve head periphery	Inlet	1.0 mm (0.039 in.)	0.6 mm (0.0236 in.)		
Exhaust		1.0 mm (0.039 in.)	0.7 mm (0.0275 in.)			
Contact width of valve and valve seat	Inlet	1.3 ~ 1.5 mm (0.0512 ~ 0.0590 in.)	_____			
	Exhaust	1.3 ~ 1.5 mm (0.0512 ~ 0.0590 in.)	_____			
Valve spring free length	Inlet	49.3 mm (1.9409 in.)	48.1 mm (1.8937 in.)			
	Exhaust	49.3 mm (1.9409 in.)	48.1 mm (1.8937 in.)			
Valve spring preload	Inlet	24.8 ~ 29.2 kg (54.7 ~ 64.3 lb) for fitting length 41.5 mm (1.63 in.)	22.8 kg (50.2 lb) for fitting length 41.5 mm (1.63 in.)			
	Exhaust	24.8 ~ 29.2 kg (54.7 ~ 64.3 lb) for fitting length 41.5 mm (1.63 in.)	22.8 kg (50.2 lb) for fitting length 41.5 mm (1.63 in.)			

Item		Standard		Service Limit	
Valve, valve spring & cam shaft	Valve stem end deflection	Inlet		0.14 mm	(0.005 in.)
		Exhaust		0.18 mm	(0.007 in.)
	Stock allowance of valve stem end face			0.5 mm	(0.019 in.)
	Valve head radial runout			0.08 mm	(0.003 in.)
	Valve spring squareness			2.0 mm	(0.079 in.)
Valve guide protrusion (In. & Ex.)		14 mm (0.55 in.)			
Rocker arm shaft and rocker arm	Rocker shaft O.D.		15.973 ~ 15.988 mm (0.628 ~ 0.629 in.)		
	Rocker arm I.D.		16.000 ~ 16.018 mm (0.629 ~ 0.630 in.)		
	Shaft-to-arm clearance	Inlet	0.012 ~ 0.045 mm (0.0005 ~ 0.0017 in.)	0.09 mm	(0.0035 in.)
		Exhaust	0.012 ~ 0.045 mm (0.0005 ~ 0.0017 in.)	0.09 mm	(0.0035 in.)
Rocker shaft runout			0.12 mm	(0.004 in.)	
Cylinder	Flatness of gasketed surface		0.03 mm (0.0012 in.)	0.06 mm	(0.0024 in.)
	Cylinder bore (S.T.D.)		74.00 ~ 74.02 mm (2.9134 ~ 2.9142 in.)	74.15 mm	(2.9193 in.)
	Cylinder bore out-of-round and taper			0.10 mm	(0.0039 in.)
	Cylinder-to-piston clearance		0.02 ~ 0.04 mm (0.0008 ~ 0.0015 in.)		
Piston	Piston diameter	Standard	73.970 ~ 73.990 mm (2.9122 ~ 2.9129 in.)		
		Oversize: 0.25 mm (0.0098 in.)	74.220 ~ 74.230 mm (2.9220 ~ 2.9224 in.)		
		Over size: 0.50 mm (0.0196 in.)	74.470 ~ 74.480 mm (2.9319 ~ 2.9322 in.)		
	Piston ring groove width	Top ring	1.22 ~ 1.24 mm (0.0480 ~ 0.0488 in.)		
		2nd ring	1.51 ~ 1.53 mm (0.0594 ~ 0.0602 in.)		
		Oil ring	2.81 ~ 2.83 mm (0.1106 ~ 0.1114 in.)		
Piston pin diameter		16.995 ~ 17.000 mm (0.6691 ~ 0.6693 in.)			
Piston ring	Piston ring thickness	Top ring	1.17 ~ 1.19 mm (0.0461 ~ 0.0468 in.)		
		2nd ring	1.47 ~ 1.49 mm (0.0578 ~ 0.0586 in.)		
		Oil ring	0.45 mm (0.0177 in.)		
	Ring clearance in groove	Top ring	0.03 ~ 0.07 mm (0.0012 ~ 0.0027 in.)	0.12 mm	(0.0047 in.)
		2nd ring	0.02 ~ 0.06 mm (0.0008 ~ 0.0023 in.)	0.10 mm	(0.0039 in.)
	Piston ring end gap	Top ring	0.20 ~ 0.33 mm (0.0079 ~ 0.0129 in.)	0.7 mm	(0.0275 in.)
2nd ring		0.20 ~ 0.35 mm (0.0079 ~ 0.0137 in.)	0.7 mm	(0.0275 in.)	
Oil ring		0.20 ~ 0.70 mm (0.0079 ~ 0.0275 in.)	1.8 mm	(0.0708 in.)	
Crank shaft	Crankshaft runout (middle)			0.06 mm	(0.0023 in.)
	Crank pin diameter		41.982 ~ 42.000 mm (1.6529 ~ 1.6535 in.)		
	Crank pin clearance in con. rod		0.030 ~ 0.050 mm (0.0012 ~ 0.0019 in.)	0.08 mm	(0.0031 in.)
	Connecting rod small end bore		16.968 ~ 16.979 mm (0.6680 ~ 0.6684 in.)		
	Crank journal diameter		44.982 ~ 45.000 mm (1.7710 ~ 1.7716 in.)		
	Bearing-to-journal clearance		0.020 ~ 0.040 mm (0.0008 ~ 0.0016 in.)	0.06 mm	(0.0023 in.)
Crank pin out-of-round and taper			0.01 mm	(0.0004 in.)	

## STEERING SYSTEM

Item	Standard	Service Limit
Gear ratio	15.6 ~ 18.1	_____
Steering angle, inside	29°	_____
Steering angle, outside	26°	_____
Steering wheel play	10 ~ 30 mm (0.4 ~ 1.2 in.)	_____

## BRAKE

Item	Standard	Service Limit
Front brake disc thickness	10 mm (0.394 in.)	8.5 mm (0.334 in.)
Front brake disc deflection	_____	0.15 mm (0.006 in.)
Front brake pad thickness (lining + pad rim)	15.0 mm (0.590 in.)	6.0 mm (0.236 in.)
Rear brake lining thickness (lining + shoe rim)	7.0 mm (0.28 in.)	3.0 mm (0.12 in.)
Rear brake drum inside diameter	220 mm (8.66 in.)	222 mm (8.74 in.)
Pedal-to-wall clearance: When pedal is depressed at 30 kg (66 lb)	75 mm (2.95 in.) minimum	_____

## ELECTRICAL

	Item	Standard	Service Limit
Ignition system	Ignition order	1 - 3 - 4 - 2	_____
	Signal rotor air gap	0.2 ~ 0.4 mm (0.008 ~ 0.016 in.)	_____
	Generator resistance	130 ~ 190 ohms	_____
	High tension cord resistance	16 kΩ/3.3 ft (1 m)	20 kΩ/pc
	Ignition coil; Primary coil resistance (20°C)	1.35 ~ 1.65 ohms	_____
	Ignition coil; Secondary coil resistance (20°C)	11.0 ~ 14.5 kiloohms	_____
	Spark plug gap	0.7 ~ 0.8 mm (0.027 ~ 0.031 in.)	_____



	Item	Standard	Service Limit
Starter motor	Voltage	12 Volts	_____
	Output	0.9 kw	_____
	Rating	30 seconds	_____
	Brush length	17 mm (0.67 in.)	11.5 mm (0.45 in.)
	Number of pinion teeth	8	_____
	Commutator diameter	32 mm (1.26 in.)	31 mm (1.22 in.)
	Mica depth	0.4 ~ 0.6 mm (0.015 ~ 0.023 in.)	0.2 mm (0.008 in.)
	Commutator out of round	0.05 mm (0.0019 in.) or less	0.4 mm (0.015 in.)
	Brush spring tension	1.6 kg (3.53 lb)	1.0 kg (2.20 lb)
Charging system	Nominal operating voltage	12 Volts	_____
	Maximum alternator output	45A	_____
	Maximum permissible alternator speed	15,000 r/min (rpm)	_____
	Working temperature range	-30 ~ 90°C (-22 ~ 194°F)	_____
	Rotor; Ring-to-ring circuit resistance	2.8 ~ 3.0 ohms	_____
	Brush length	11.0 mm (0.43 in.)	5.0 mm (0.20 in.)
	Standard output voltage and current	14.2 ~ 14.8 Volts, 10A maximum	_____
	Regulated voltage	14.2 ~ 14.8 Volts	_____