ANTI-RUST TREATMENT

	Page
GENERAL INFORMATION	AR-2
BODY PANEL SEALING AREAS	AR-4
BODY PANEL UNDERCOATING AREAS	AR-12
BODY PANEL ANTI-RUST AGENT APPLICATION AREAS	AR-13
BODY PANEL ANTI-CHIPPING PAINT APPLICATION AREAS	AR-14

GENERAL INFORMATION

Anti-rust treatment is necessary before welding and before and after the painting process.

ANTI-RUST TREATMENT BEFORE WELDING

1. WELD-THROUGH PRIMER (SPOT SEALER) APPLICATION

For anti-corrosion measures, always apply the weld-through primer (spot sealer) to welding surfaces where the paint film has been removed.

HINT: Apply the weld-through primer (spot sealer) so that it does not ooze out from the joining surfaces.

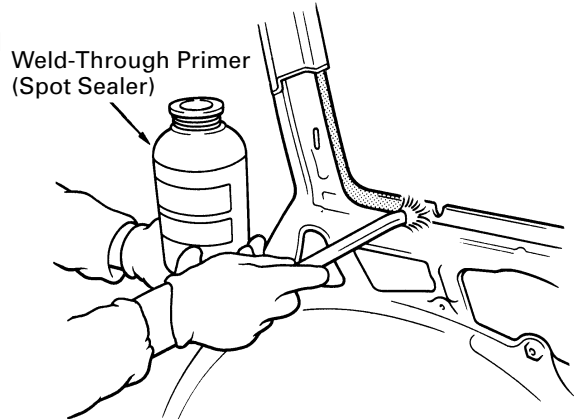

WELD-THROUGH PRIMER (SPOT SEALER) APPLICATION

ANTI-RUST TREATMENT BEFORE PAINTING PROCESS

1. BODY SEALER APPLICATION

For water-proofing and anti-corrosion measures, always apply the body sealer to the body panel seams and hems of the doors, hoods, etc.

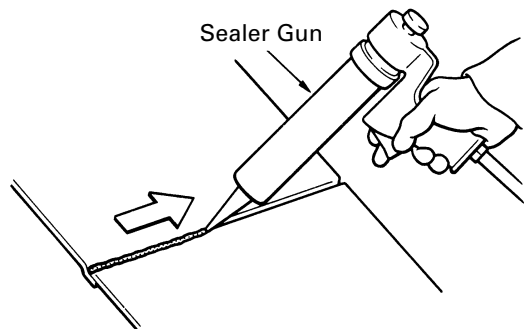

BODY SEALER APPLICATION

2. UNDERCOAT APPLICATION

To prevent corrosion and protect the body from damage by flying stones, always apply sufficient undercoat to the bottom surface of the under body and inside of the wheel housings.

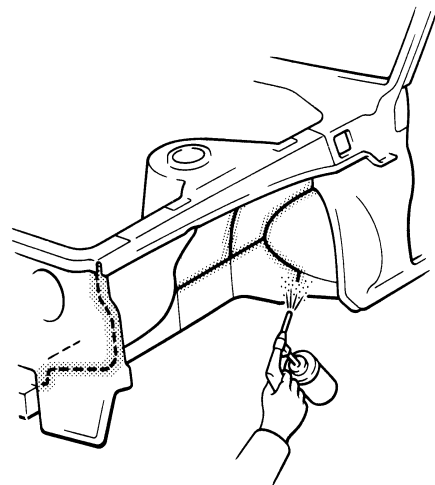

UNDERCOAT APPLICATION

ANTI-RUST TREATMENT AFTER PAINTING PROCESS

1. ANTI-RUST AGENT (WAX) APPLICATION

To preserve impossible to paint areas from corrosion, always apply sufficient anti-rust agent (wax) to the inside of the hemming areas of the doors and hoods, and around the hinges, or the welded surfaces inside the boxed cross-section structure of the side member, body pillar, etc.

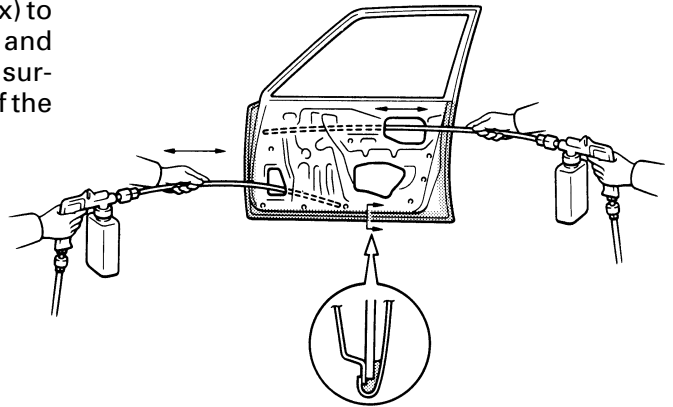

ANTI-RUST AGENT (WAX) APPLICATION

REFERENCE: ANTI-RUST TREATMENT BY PAINTING

Painting prevents corrosion and protects the sheet metal from damage. In this section, anti-chipping paint only for anti-corrosion purpose is described.

1. ANTI-CHIPPING PAINT

To prevent corrosion and protect the body from damage by flying stones, etc., apply anti-chipping paint to the rocker panel, wheel arch areas, valance panel, etc.

HINT:

Depending on the model or the application area, there are cases where the application of anti-chipping paint is necessary before the second coat or after the top coat.

- Apply the anti-chipping paint after the top coat.

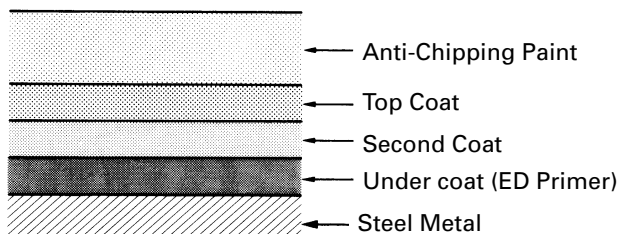

- Apply the anti-chipping paint before the second coat.

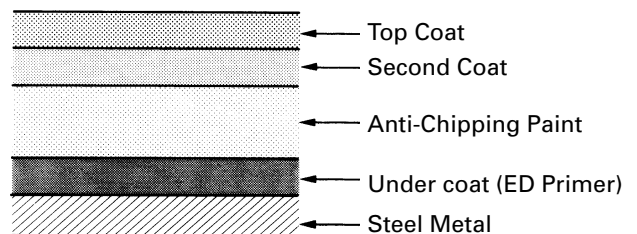

BODY PANEL SEALING AREAS

HINT:

1. Prior to applying body sealer, clean the area with a rag soaked in a grease, wax and silicone remover.
2. If weld-through primer was used, first wipe off any excess and coat with anti-corrosion primer before applying body sealer.
3. Wipe off excess body sealer with a rag soaked in a grease, wax and silicone remover.
4. If body sealer is damaged by peeling, cracks, etc., be sure to repair as necessary.

ALL

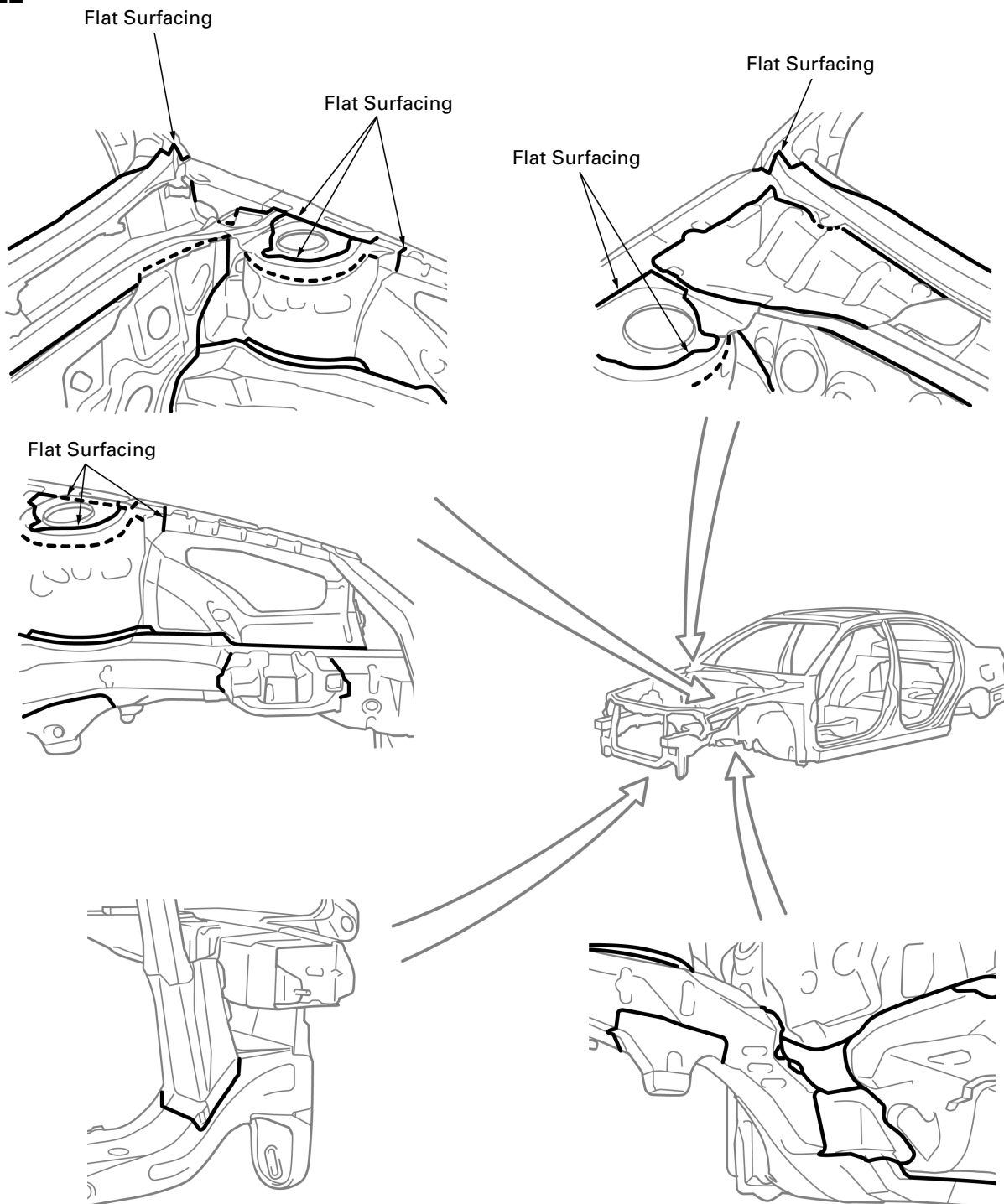

ALL

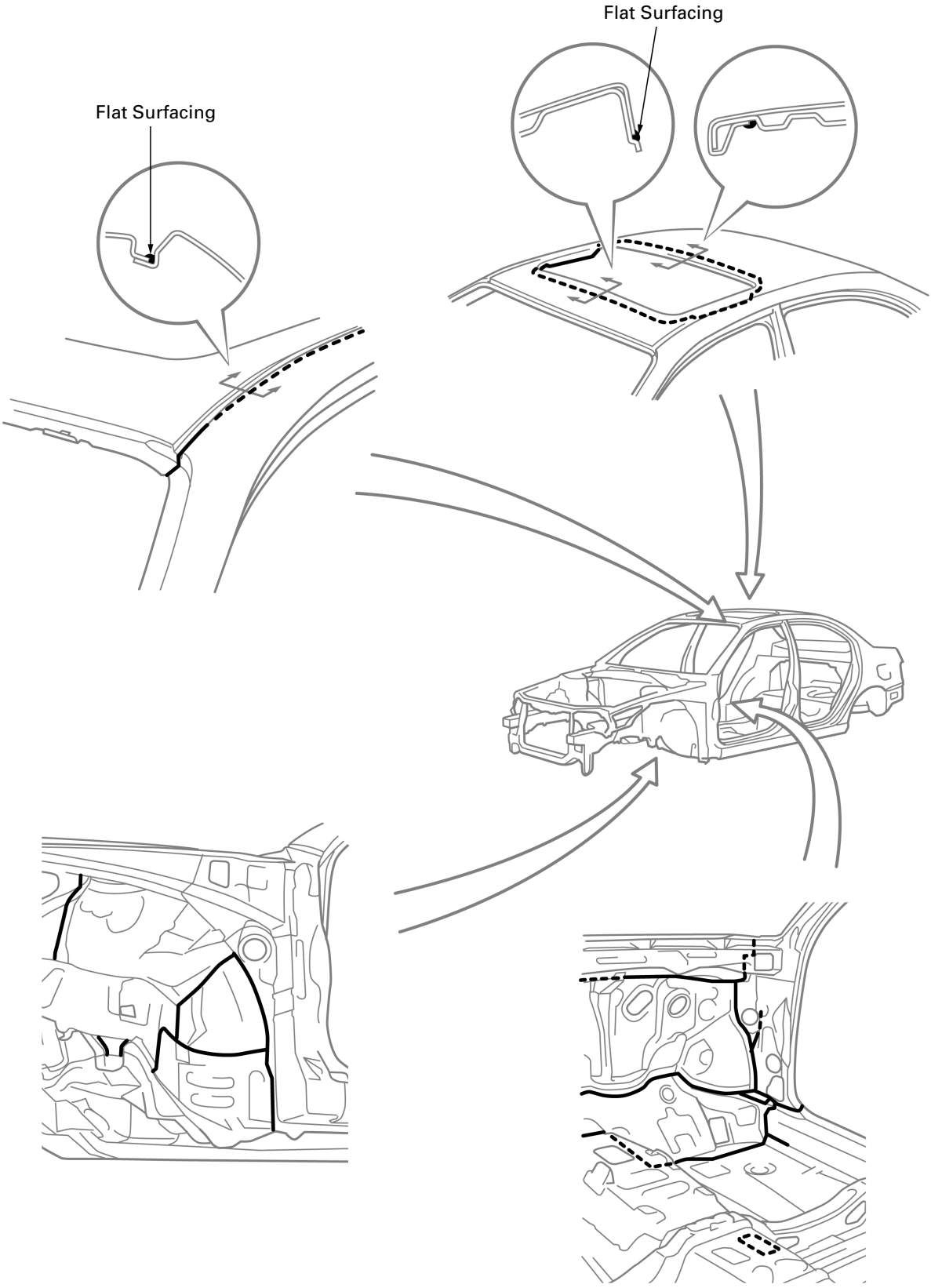

ALL

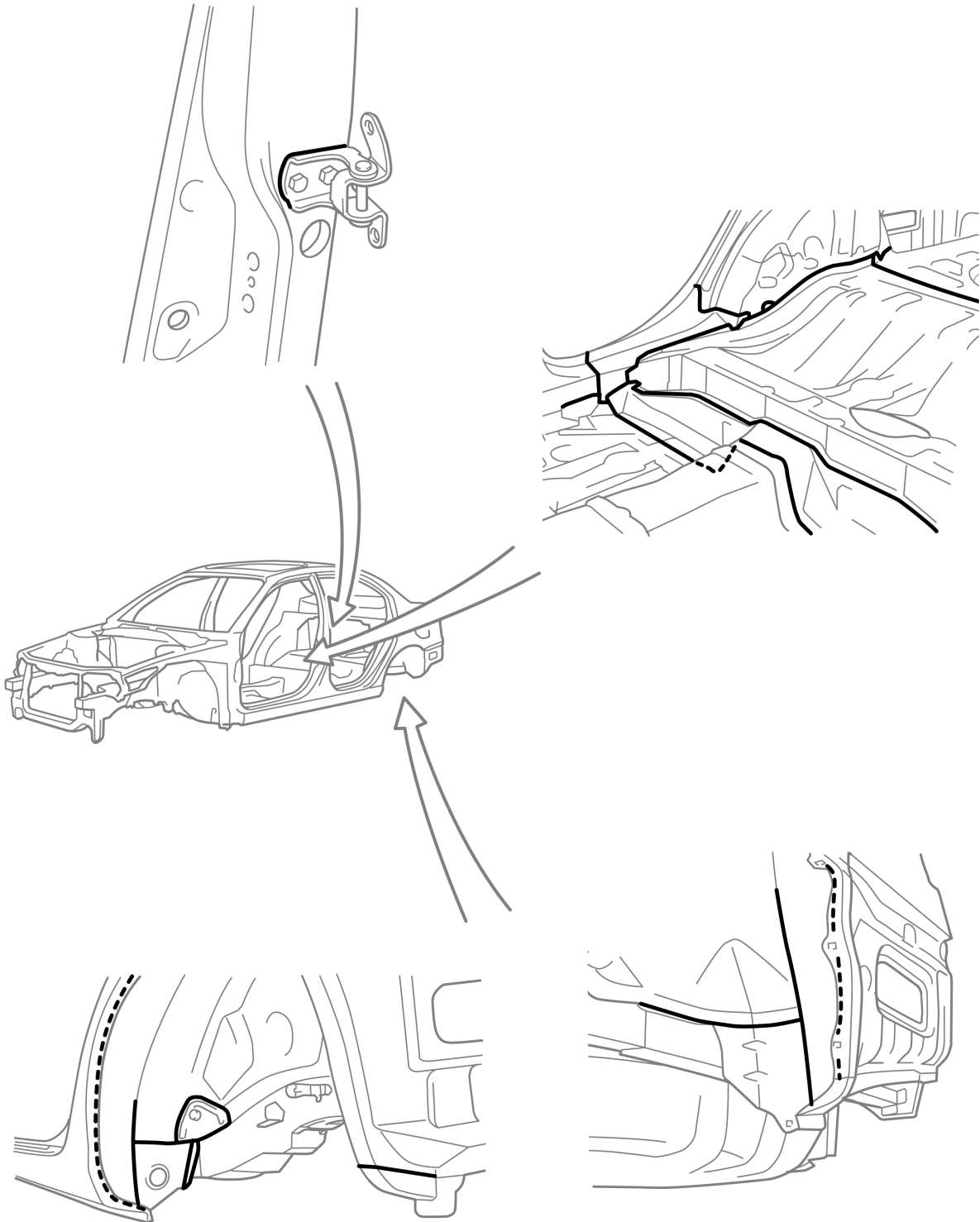

SEDAN

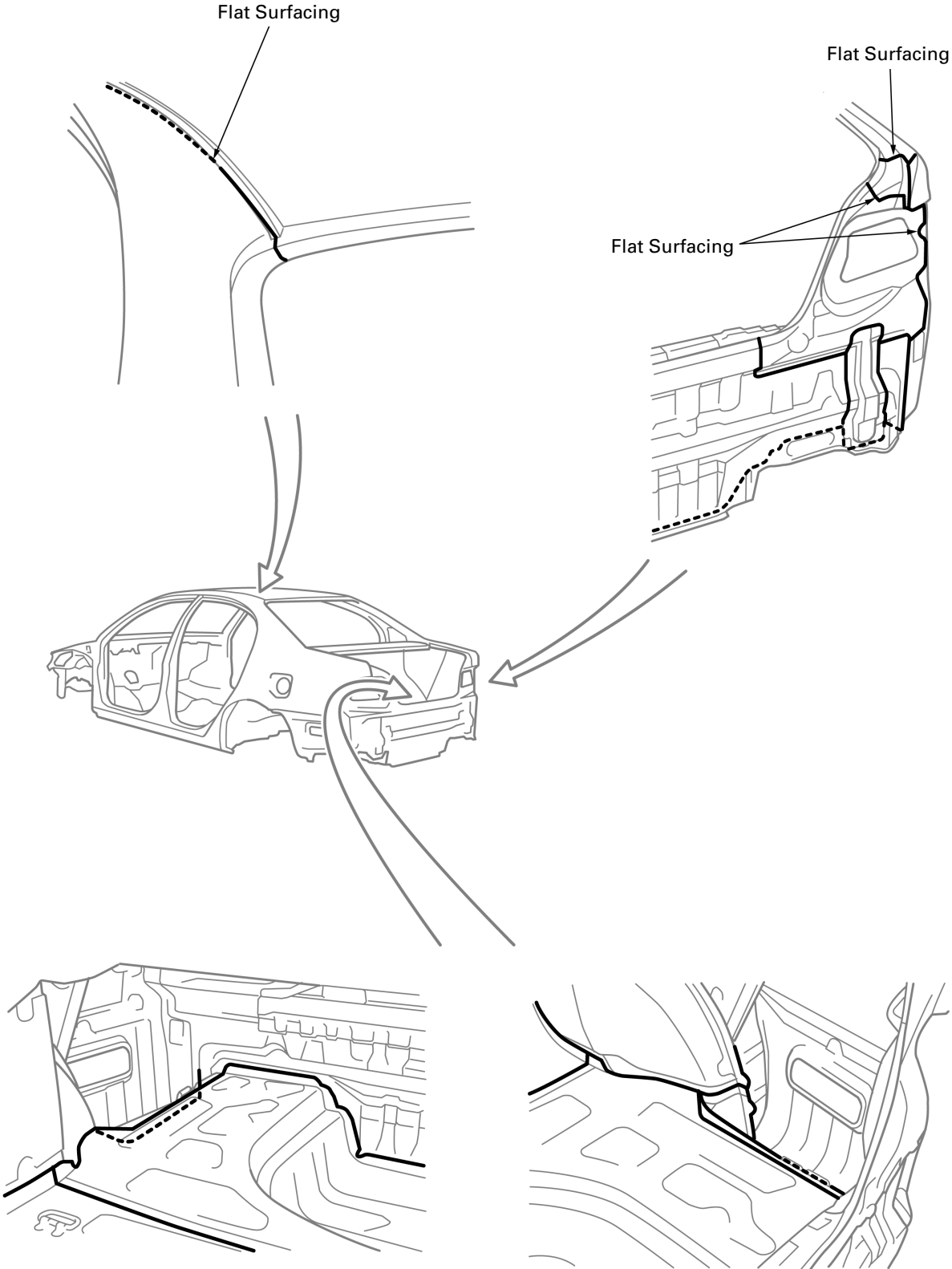

LIFTBACK

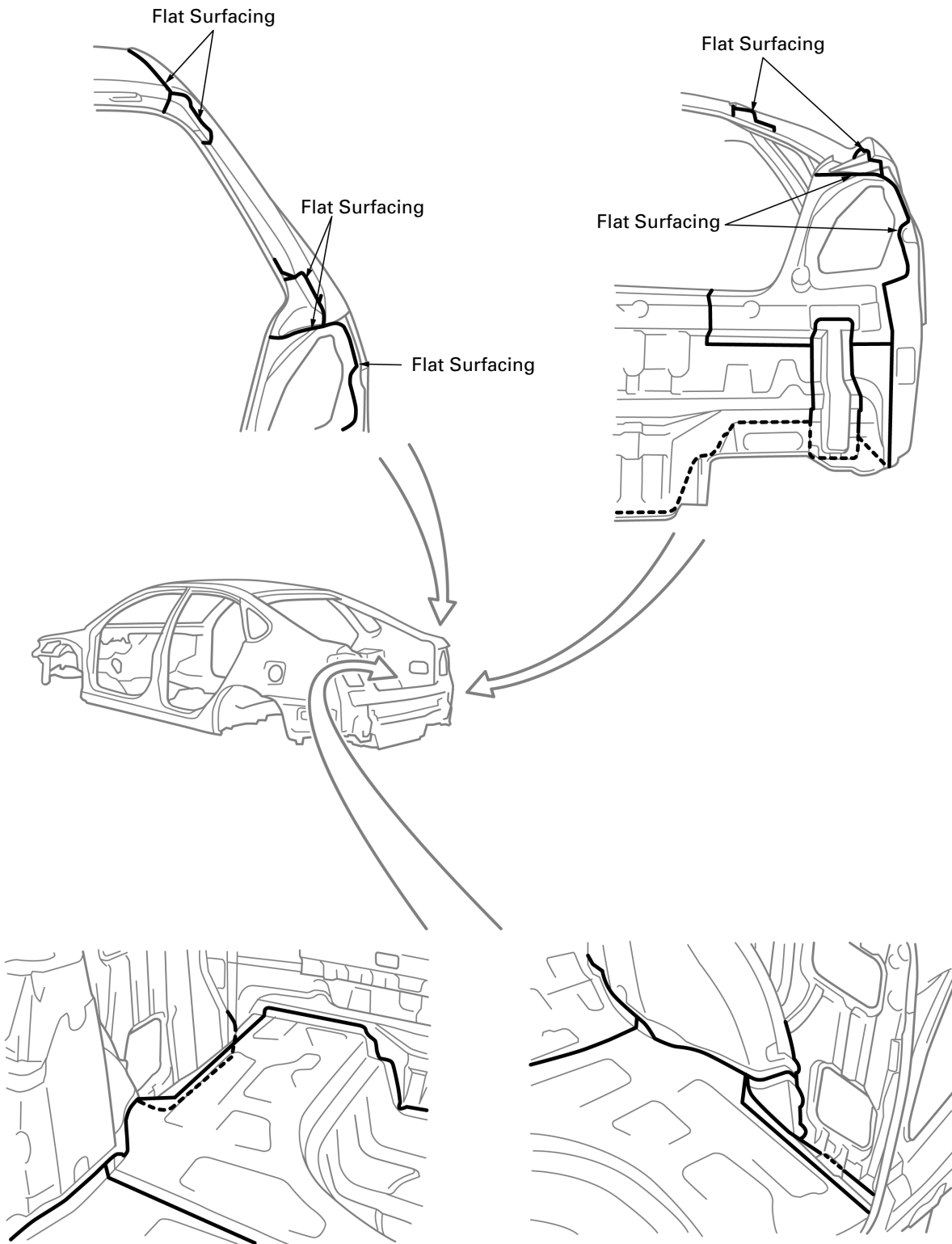

WAGON

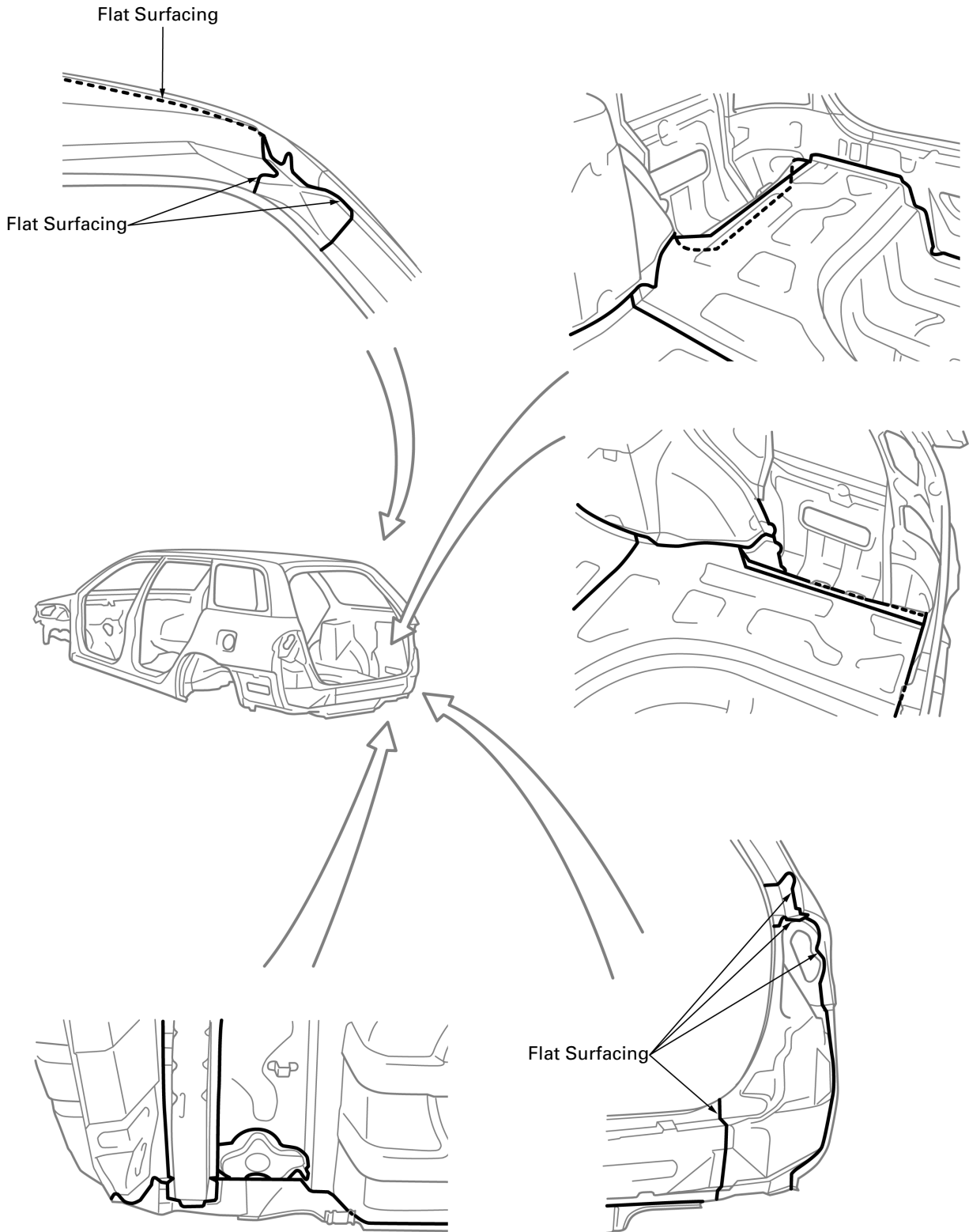

ALL

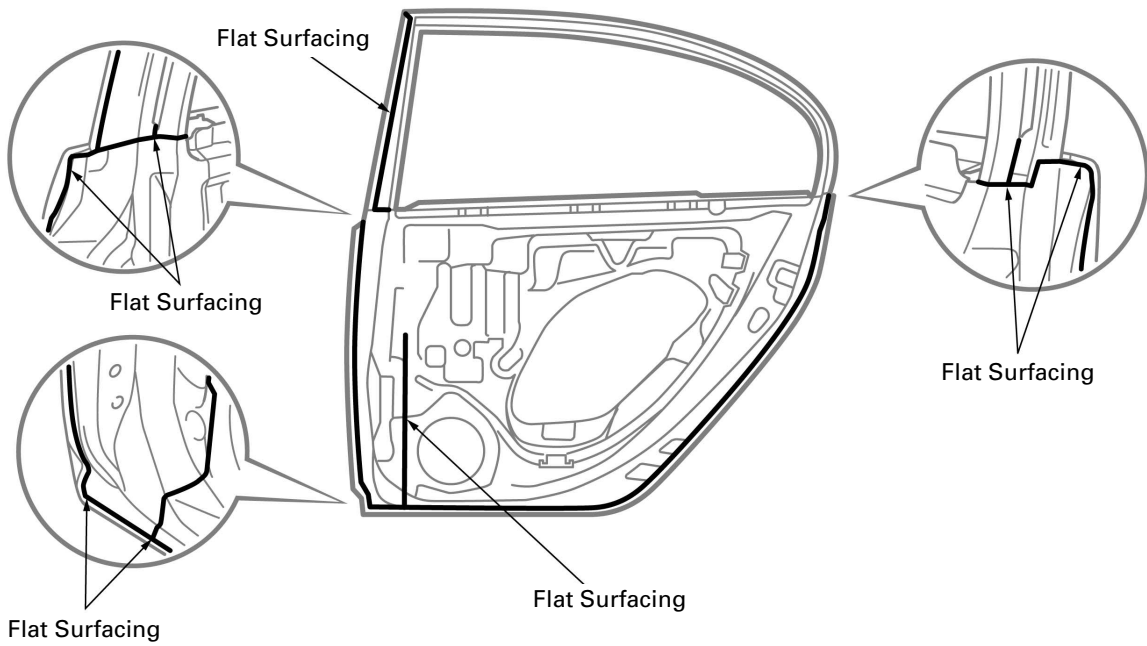
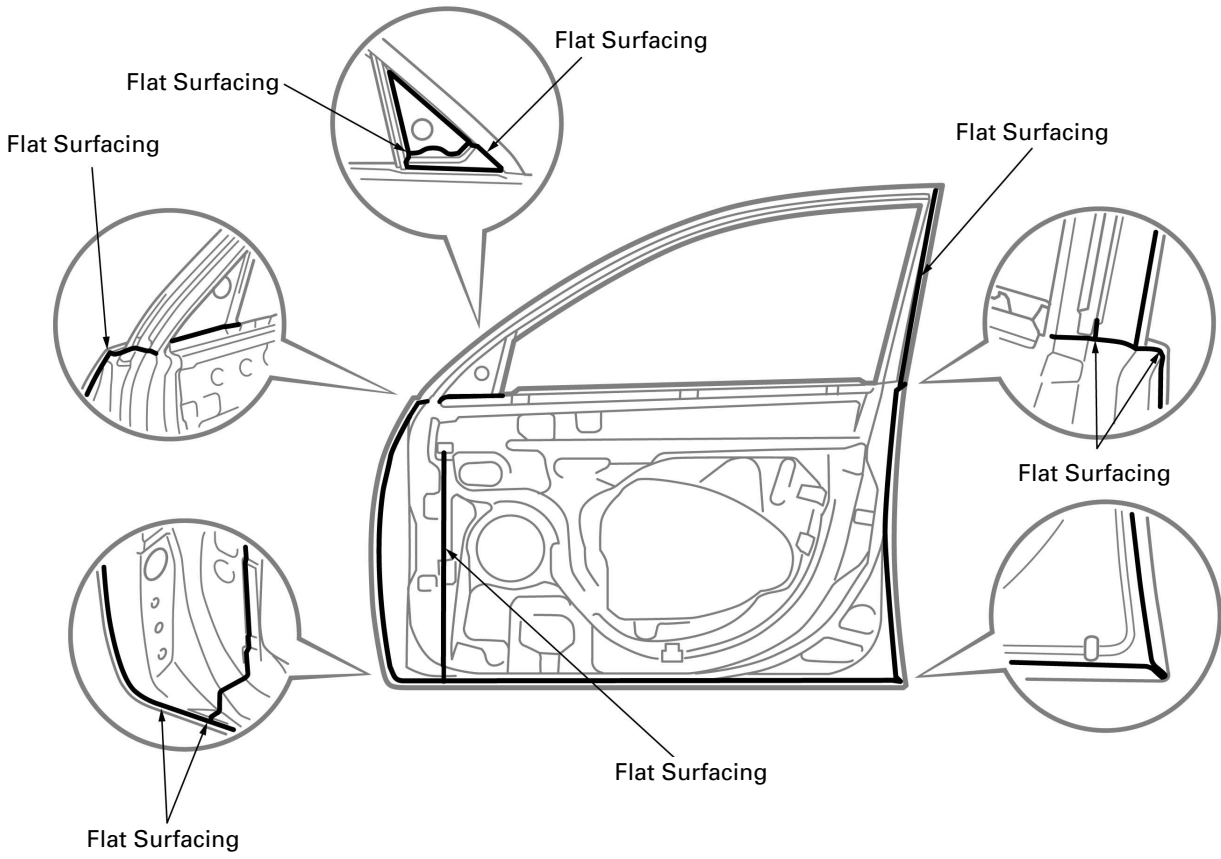

[ALL]

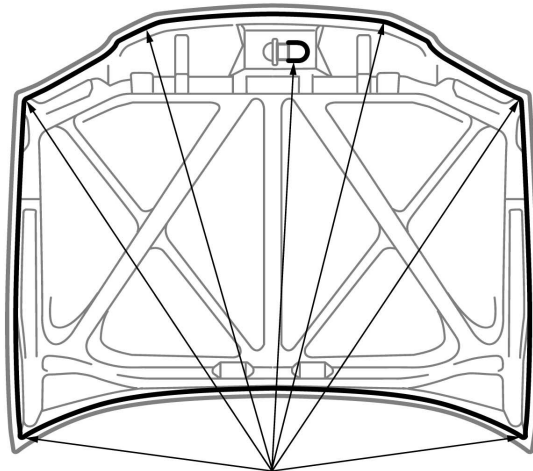

Flat Surfacing

[SEDAN]

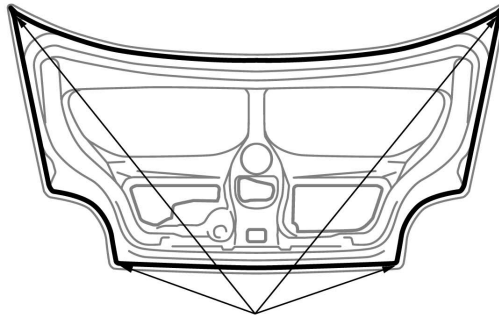

Flat Surfacing

[LIFTBACK]

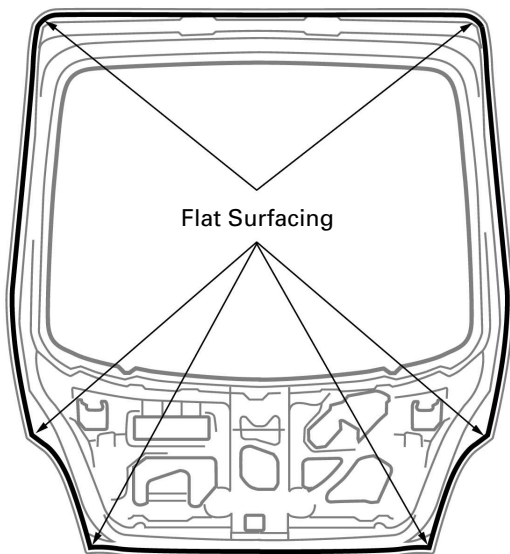

Flat Surfacing

[WAGON]

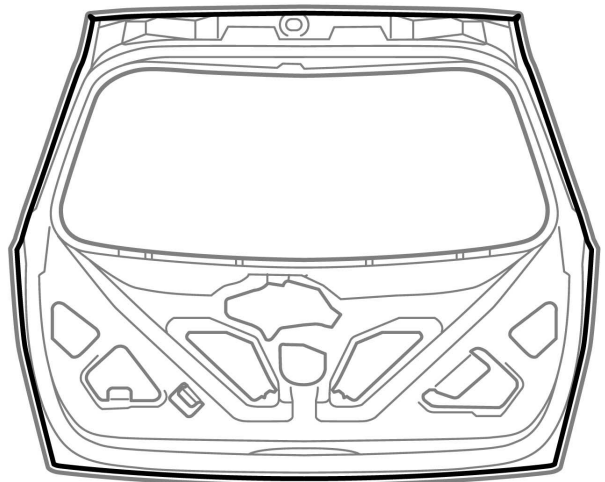

BODY PANEL UNDERCOATING AREAS

HINT:

1. First wipe off any dirt, grease or oil with a rag soaked in a grease, wax and silicone remover.
2. Cover the surrounding areas with masking paper to avoid coating unnecessary areas. If other areas are accidentally coated, wipe off the coating immediately.
3. Apply the first coating of undercoat to all welded areas and panel joints, then apply a second coat over the entire area.
4. Do not coat parts which become hot, such as the tailpipe, or moving parts, such as the propeller shaft.
5. Besides the locations described below, apply undercoating to all weld points under the body to insure corrosion prevention.
6. Be sure to seal the edge of the flange of the member and bracket with undercoating.
7. If undercoat is damaged by peeling, cracks, etc., be sure to repair as necessary.
8. Before the undercoat apply sealer allowing rust prevention to be attained.

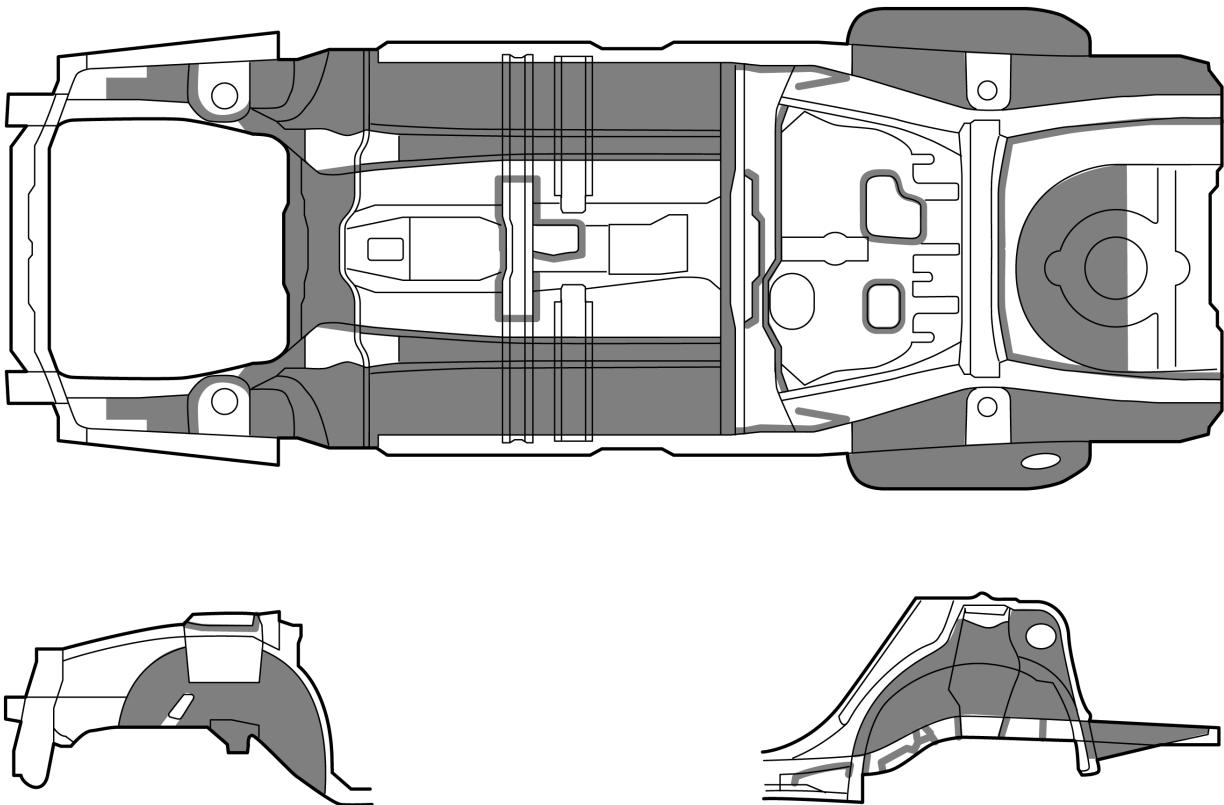

REFERENCE: Referring to the notes above, undercoating should be applied according to the specifications for your country.

BODY PANEL ANTI-RUST AGENT (WAX) APPLICATION AREAS

HINT:

1. Whenever adjusting the doors and hoods, apply anti-rust agent (wax) around the hinges.
2. Even if partially repairing a part, apply anti-rust agent (wax) over the entire application area of the part.
3. Wipe off the anti-rust agent immediately with a rag soaked in a grease, wax and silicone remover, if accidentally applied to other areas.

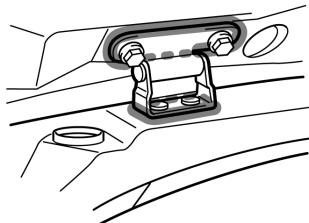

Back Door Hinge

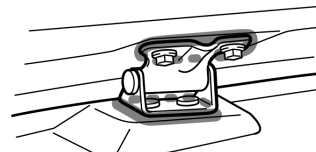

Back Door Hinge

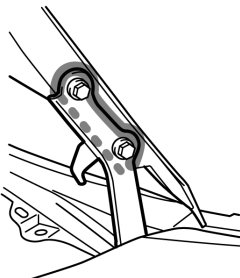
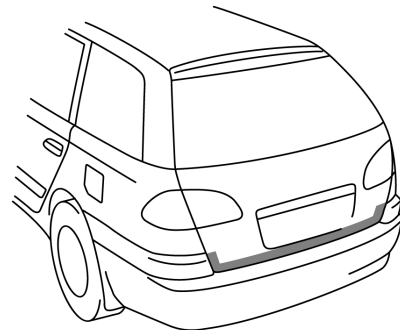
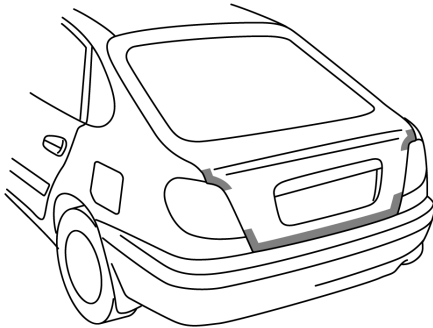

Hood Hinge



Back Door

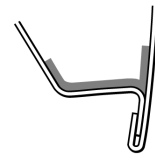

Back Door

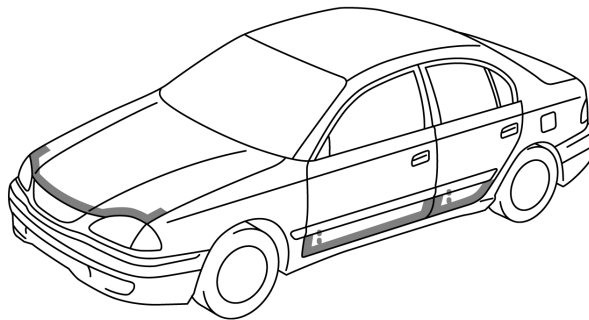

Hood

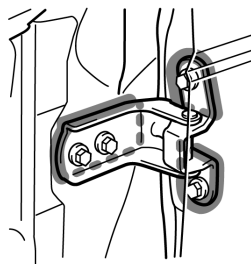

Door Hinge

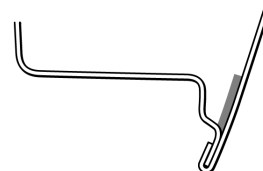

Front Door, Rear Door

BODY PANEL ANTI-CHIPPING PAINT APPLICATION AREAS

HINT:

1. *Anti-chipping paint should be applied to some areas before the second coat and to others after the top coat.*
2. *If other areas are accidentally coated, wipe off the paint immediately with a rag soaked in a grease, wax and silicone remover.*

