

# RADIO AND PLAYER

FROM POWER SOURCE SYSTEM (SEE PAGE 40)

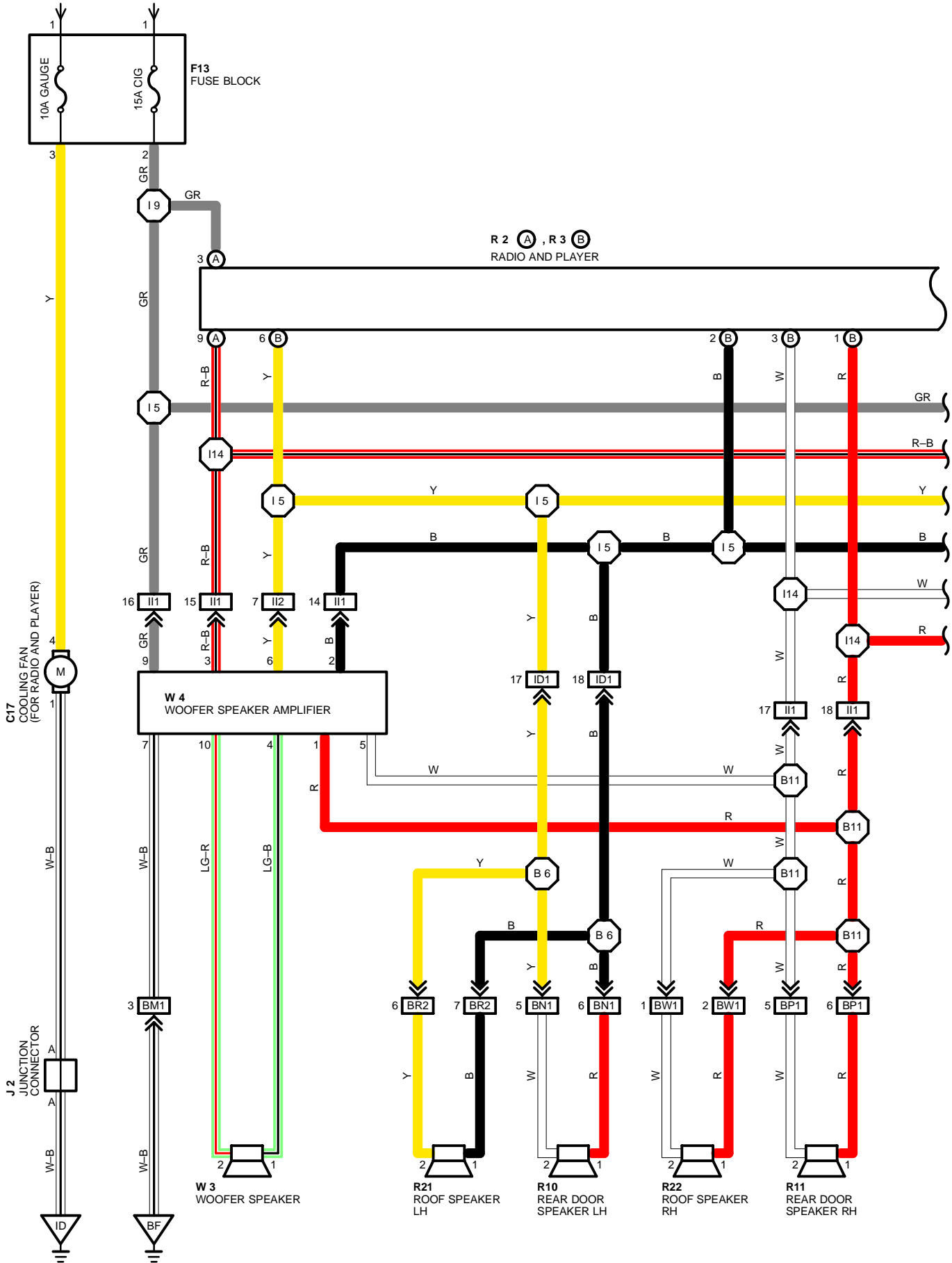

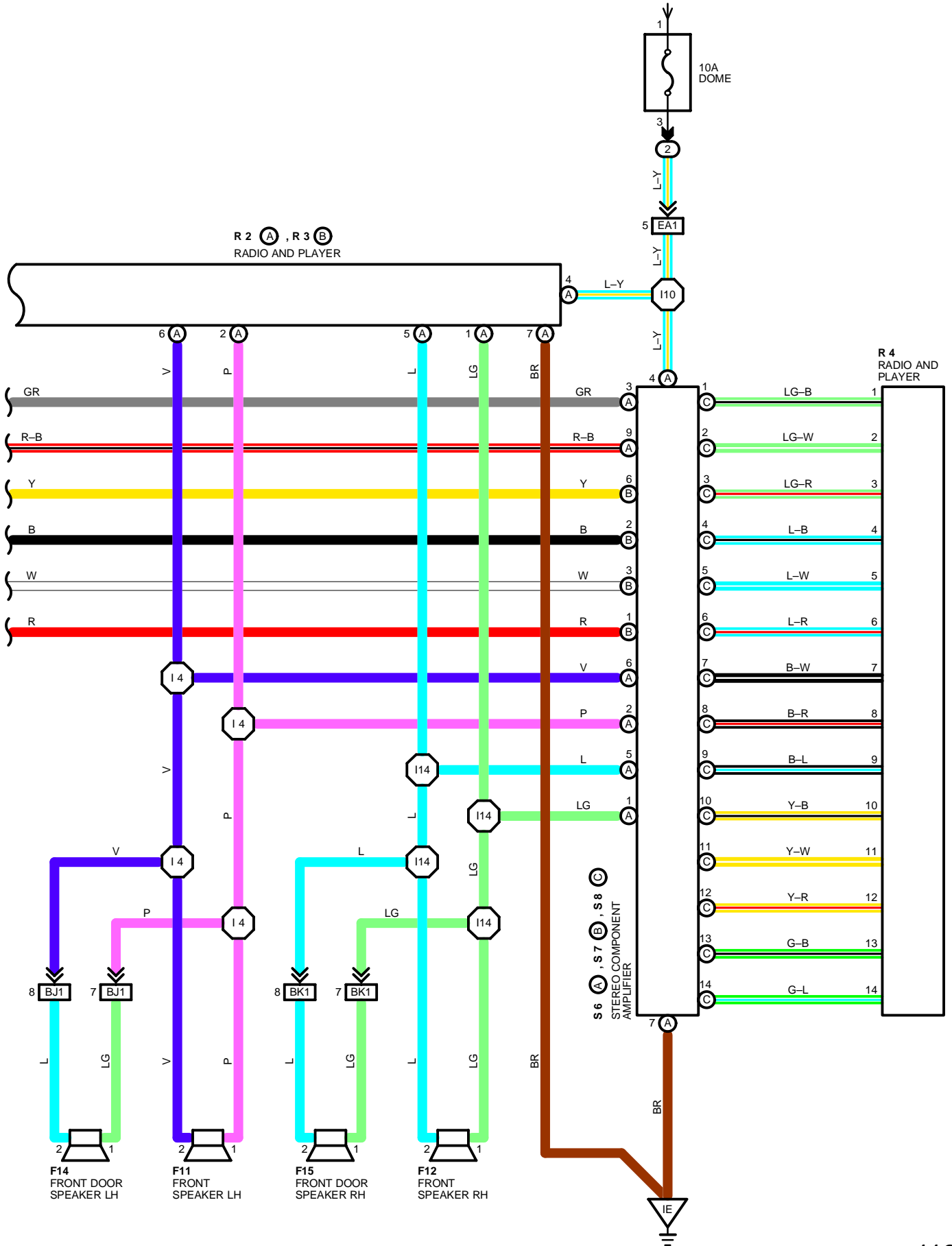

# RADIO AND PLAYER

## SERVICE HINTS

### R 2(A) RADIO AND PLAYER

(A) 4-GROUND : ALWAYS APPROX. 12 VOLTS

(A) 3-GROUND : APPROX. 12 VOLTS WITH IGNITION SW AT **ACC** OR **ON** POSITION

(A) 7-GROUND : ALWAYS CONTINUITY

### ○ : PARTS LOCATION

CODE	SEE PAGE	CODE	SEE PAGE	CODE	SEE PAGE
C17	20	R 2	A 20	S 6	A 20
F11	20	R 3	B 20	S 7	B 20
F12	20	R 4	20	S 8	C 20
F13	20	R10	21	W 3	21
F14	21	R11	21	W 4	21
F15	21	R21	21		
J 2	20	R22	21		

### ○ : RELAY BLOCKS

CODE	SEE PAGE	RELAY BLOCKS (RELAY BLOCK LOCATION)
2	16	R/B NO. 2 (FRONT SIDE OF LEFT FENDER)

### □ : CONNECTOR JOINING WIRE HARNESS AND WIRE HARNESS

CODE	SEE PAGE	JOINING WIRE HARNESS AND WIRE HARNESS (CONNECTOR LOCATION)
EA1	22	COWL WIRE AND ENGINE ROOM MAIN WIRE (LEFT FENDER)
ID1	24	COWL WIRE AND FLOOR NO. 1 WIRE (LEFT KICK PANEL)
II1	24	COWL WIRE AND FLOOR NO. 2 WIRE (RIGHT KICK PANEL)
II2		
BJ1	26	FRONT DOOR LH WIRE AND COWL WIRE (LEFT KICK PANEL)
BK1	26	FRONT DOOR RH WIRE AND COWL WIRE (RIGHT KICK PANEL)
BM1	26	FLOOR NO. 2 WIRE AND FLOOR NO. 1 WIRE (UNDER THE CENTER CONSOLE BOX)
BN1	26	REAR DOOR LH WIRE AND FLOOR NO. 1 WIRE (LEFT CENTER PILLAR)
BP1	26	REAR DOOR RH WIRE AND FLOOR NO. 2 WIRE (RIGHT CENTER PILLAR)
BR2	28	LUGGAGE ROOM NO. 1 WIRE AND FLOOR NO. 1 WIRE (LEFT QUARTER PANEL INNER)
BW1	28	ROOF NO. 2 WIRE AND FLOOR NO. 2 WIRE (RIGHT QUATER PANEL INNER)

### ▽ : GROUND POINTS

CODE	SEE PAGE	GROUND POINTS LOCATION
ID	24	LEFT KICK PANEL
IE	24	RIGHT KICK PANEL
BF	26	UNDER THE CENTER CONSOLE BOX

### ○ : SPLICE POINTS

CODE	SEE PAGE	WIRE HARNESS WITH SPLICE POINTS	CODE	SEE PAGE	WIRE HARNESS WITH SPLICE POINTS
I 4	24	COWL WIRE	I14	24	COWL WIRE
I 5			B 6	28	FLOOR NO. 1 WIRE
I 9			B11	28	FLOOR NO. 2 WIRE
I10					

C17

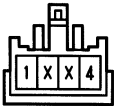

F11, F12

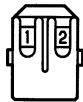

F13

(SEE PAGE 18)

F14, F15



J 2



(HINT:SEE PAGE 7)

R 2 (A)

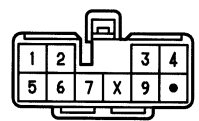

R 3 (B)

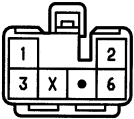

R 4

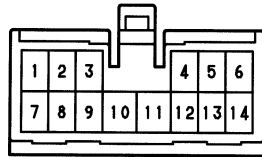

R10, R11



R21, R22



S 6 (A)

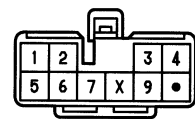

S 7 (B)



S 8 (C)

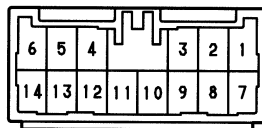

W 3

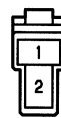

W 4

