

# A/T INDICATOR

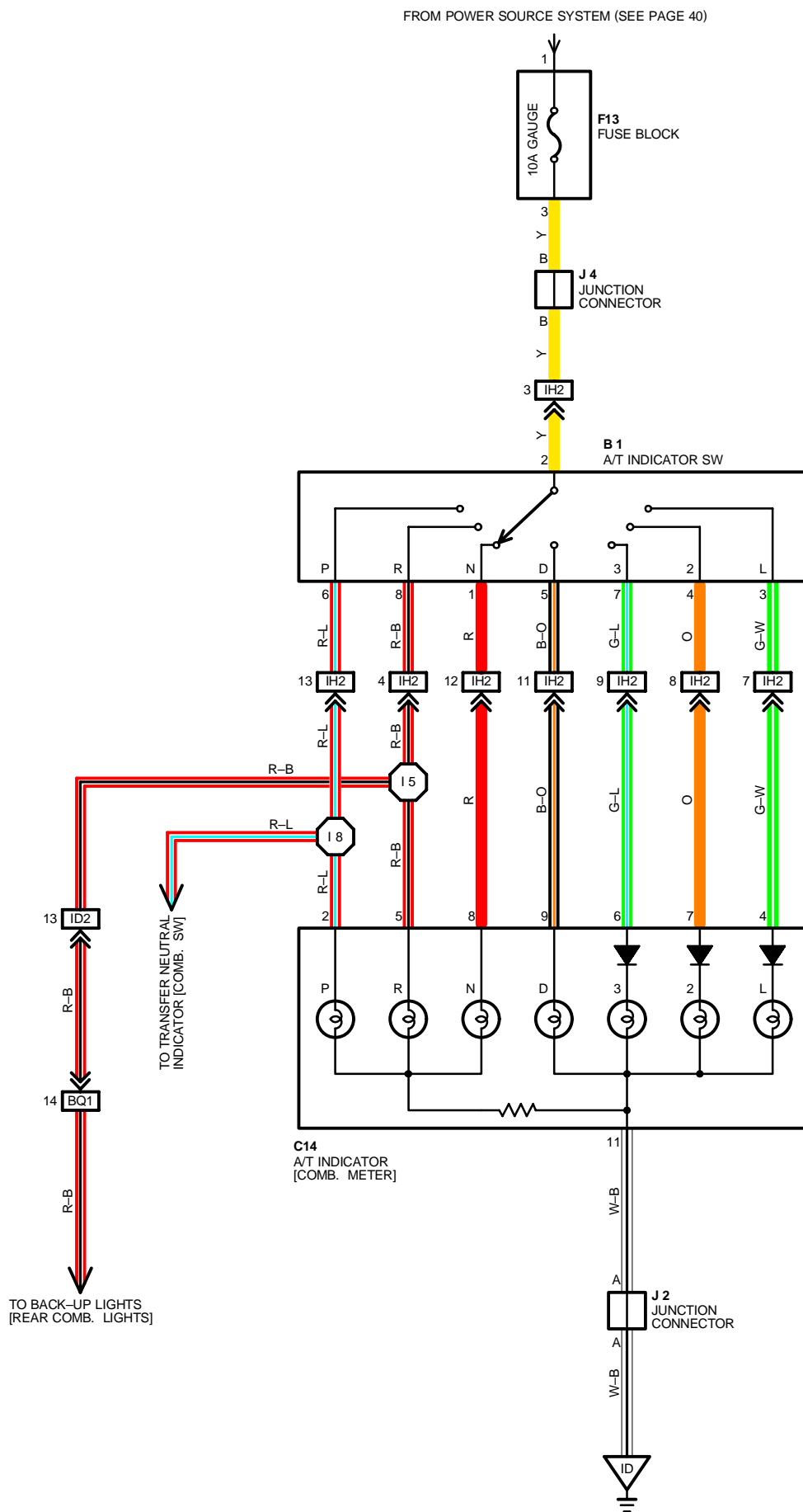

**○ : PARTS LOCATION**

CODE	SEE PAGE	CODE	SEE PAGE	CODE	SEE PAGE
<b>B 1</b>	19	<b>F13</b>	20	<b>J 4</b>	20
<b>C14</b>	20	<b>J 2</b>	20		

**□ : CONNECTOR JOINING WIRE HARNESS AND WIRE HARNESS**

CODE	SEE PAGE	JOINING WIRE HARNESS AND WIRE HARNESS (CONNECTOR LOCATION)
<b>ID2</b>	24	COWL WIRE AND FLOOR NO. 1 WIRE (LEFT KICK PANEL)
<b>IH2</b>	24	ENGINE WIRE AND COWL WIRE (BEHIND GLOVE BOX)
<b>BQ1</b>	26	FLOOR NO. 3 WIRE AND FLOOR NO. 1 WIRE (LEFT QUARTER PANEL INNER)

**▽ : GROUND POINTS**

CODE	SEE PAGE	GROUND POINTS LOCATION
<b>ID</b>	24	LEFT KICK PANEL

**○ : SPLICE POINTS**

CODE	SEE PAGE	WIRE HARNESS WITH SPLICE POINTS	CODE	SEE PAGE	WIRE HARNESS WITH SPLICE POINTS
<b>I 5</b>	24	COWL WIRE	<b>I 8</b>	24	COWL WIRE

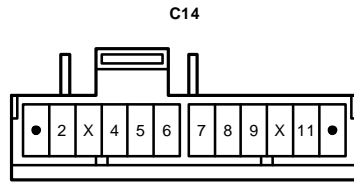

**F13**  
(SEE PAGE 18)

