

# SHIFT LOCK

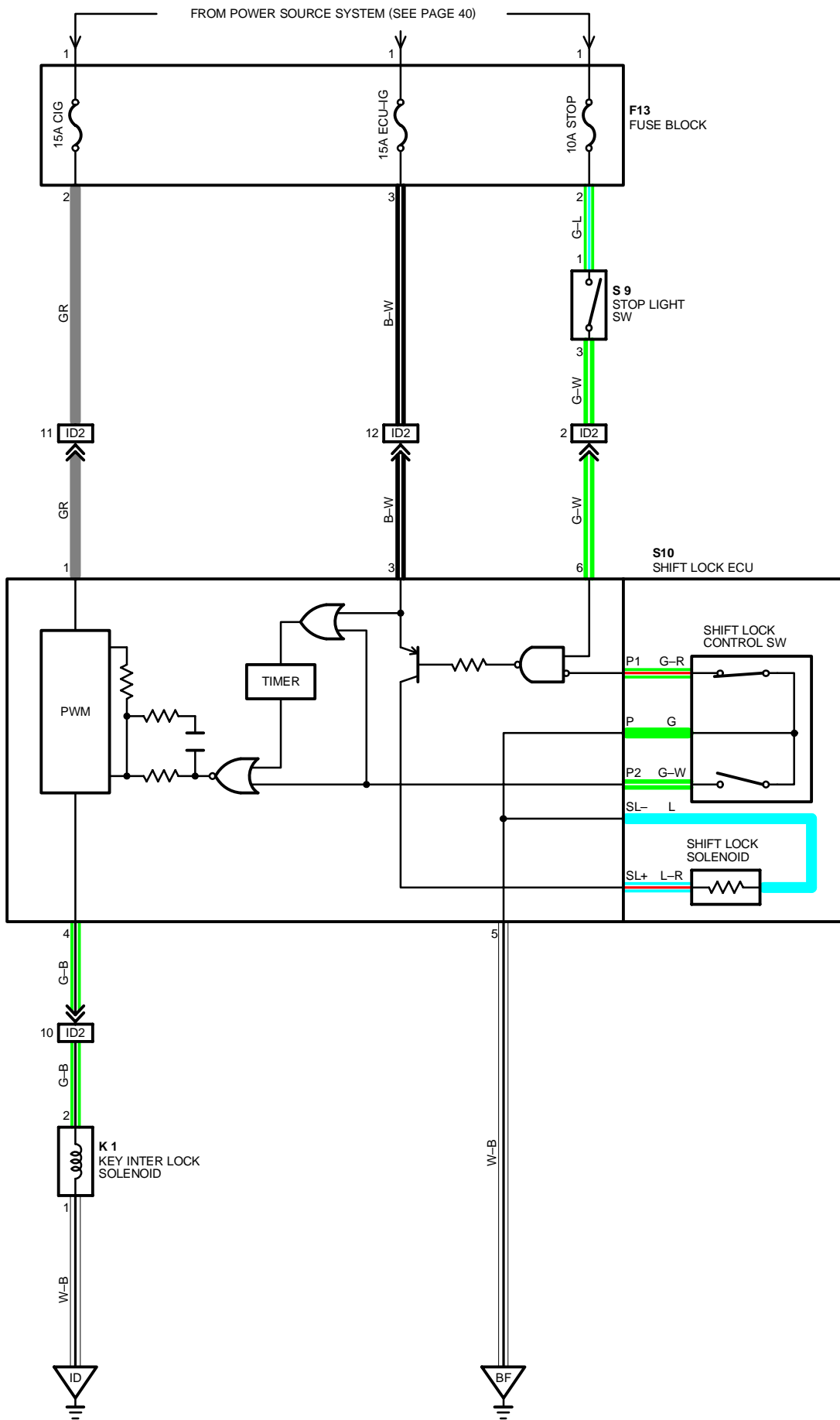

## SYSTEM OUTLINE

WHEN THE IGNITION SW IS TURNED TO **ACC** POSITION THE CURRENT FROM THE CIG FUSE FLOWS TO **TERMINAL 1** OF THE SHIFT LOCK ECU. IN THE **ON** POSITION, THE CURRENT FROM THE ECU-IG FUSE FLOWS TO **TERMINAL 3** OF THE ECU.

### 1. SHIFT LOCK MECHANISM

WITH THE IGNITION SW ON, WHEN A SIGNAL THAT THE BRAKE PEDAL IS DEPRESSED (STOP LIGHT SW ON) AND A SIGNAL THAT THE SHIFT LEVER IS PUT IN "P" RANGE (CONTINUITY BETWEEN P1 AND P OF THE SHIFT POSITION SW) IS INPUT TO THE ECU. THE ECU OPERATES AND CURRENT FLOWS FROM **TERMINAL 3** OF THE ECU → **TERMINAL SL+** OF THE SHIFT LOCK SOLENOID → SOLENOID → **TERMINAL SL-** → **TERMINAL 5** OF THE ECU → **GROUND**. THIS CAUSES THE SHIFT LOCK SOLENOID TO TURN ON (PLATE STOPPER DISENGAGES) AND THE SHIFT LEVER CAN SHIFT INTO OTHER RANGE THAN THE "P" RANGE.

### 2. KEY INTER LOCK MECHANISM

WITH THE IGNITION SW IN **ON** OR **ACC** POSITION, WHEN THE SHIFT LEVER IS PUT IN "P" RANGE (NO CONTINUITY BETWEEN P2 AND P OF LOCK CONTROL SW). THE CURRENT FLOWING FROM **TERMINAL 4** OF THE ECU → KEY INTER LOCK SOLENOID IS CUT OFF. THIS CAUSES THE KEY INTER LOCK SOLENOID TO TURN OFF (LOCK LEVER DISENGAGES FROM LOCK POSITION) AND THE IGNITION KEY CAN BE TURNED FROM **ACC** TO **LOCK** POSITION. IF THE IGNITION IS LEFT IN **ACC** OR **ON** POSITION WITH THE SHIFT LEVER IN OTHER THAN "P" RANGE, THEN AFTER APPROX, ONE HOUR THE ECU OPERATES TO RELEASE THE LOCK.

## SERVICE HINTS

### S 10 SHIFT LOCK ECU

- 1-GROUND : APPROX. 12 VOLTS WITH IGNITION SW AT **ACC** OR **ON** POSITION
- 3-GROUND : APPROX. 12 VOLTS WITH IGNITION SW AT **ON** POSITION
- 5-GROUND : ALWAYS CONTINUITY
- 6-GROUND : APPROX. 12 VOLTS WITH BRAKE PEDAL DEPRESSED

### ○ : PARTS LOCATION

CODE	SEE PAGE	CODE	SEE PAGE	CODE	SEE PAGE
<b>F13</b>	20	<b>S 9</b>	20		
<b>K 1</b>	20	<b>S10</b>	21		

### □ : CONNECTOR JOINING WIRE HARNESS AND WIRE HARNESS

CODE	SEE PAGE	JOINING WIRE HARNESS AND WIRE HARNESS (CONNECTOR LOCATION)
<b>ID2</b>	24	COWL WIRE AND FLOOR NO. 1 WIRE (LEFT KICK PANEL)

### ▽ : GROUND POINTS

CODE	SEE PAGE	GROUND POINTS LOCATION
<b>ID</b>	24	LEFT KICK PANEL
<b>BF</b>	26	UNDER THE CENTER CONSOLE BOX

**F13**  
(SEE PAGE 18)

