

INTERIOR LIGHT

FROM POWER SOURCE SYSTEM (SEE PAGE 40)

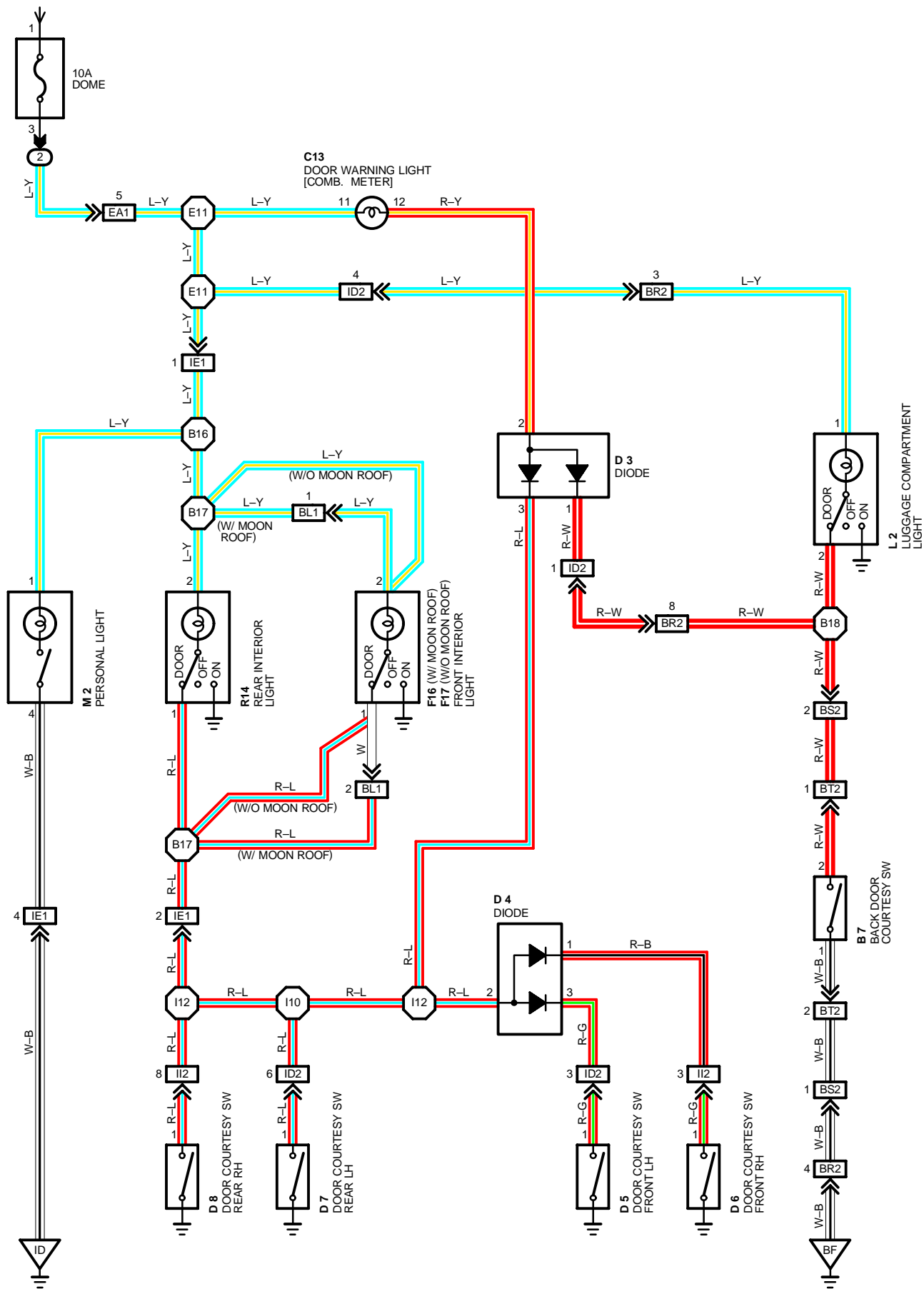

SERVICE HINTS

F16, F17 INTERIOR LIGHT

2-GROUND : APPROX. 12VOLTS WITH INTERIOR LIGHT SW AT **ON** OR **OFF** POSITION

2-1 : CLOSED WITH SW AT **DOOR** POSITION

D 5, D 6, D 7, D 8 DOOR COURTESY SW

1-GROUND : CLOSED WITH DOOR OPEN

B 7 BACK DOOR COURTESY SW

1-GROUND : CLOSED WITH BACK DOOR OPEN

○ : PARTS LOCATION

CODE	SEE PAGE	CODE	SEE PAGE	CODE	SEE PAGE
B 7	21	D 6	21	L 2	21
C13	20	D 7	21	M 2	21
D 3	20	D 8	21	R14	21
D 4	20	F16	21		
D 5	21	F17	21		

○ : RELAY BLOCKS

CODE	SEE PAGE	RELAY BLOCKS (RELAY BLOCK LOCATION)
2	16	R/B NO. 2 (FRONT SIDE OF LEFT FENDER)

□ : CONNECTOR JOINING WIRE HARNESS AND WIRE HARNESS

CODE	SEE PAGE	JOINING WIRE HARNESS AND WIRE HARNESS (CONNECTOR LOCATION)
EA1	22	COWL WIRE AND ENGINE ROOM MAIN WIRE (LEFT FENDER)
ID2	24	COWL WIRE AND FLOOR NO. 1 WIRE (LEFT KICK PANEL)
IE1	24	ROOF NO. 1 WIRE AND COWL WIRE (LEFT KICK PANEL)
II2	24	COWL WIRE AND FLOOR NO. 2 WIRE (RIGHT KICK PANEL)
BL1	26	ROOF NO. 1 AND ROOF NO. 3 WIRE (ROOF LEFT)
BR2	28	LUGGAGE ROOM NO. 1 WIRE AND FLOOR NO. 1 WIRE (LEFT QUARTER PANEL INNER)
BS2	28	BACK DOOR NO. 1 WIRE AND LUGGAGE ROOM NO. 1 WIRE (LEFT REAR SIDE OF ROOF)
BT2	28	BACK DOOR NO. 1 WIRE AND BACK DOOR NO. 2 WIRE (BACK DOOR LEFT)

▽ : GROUND POINTS

CODE	SEE PAGE	GROUND POINTS LOCATION
ID	24	LEFT KICK PANEL
BF	26	UNDER THE CENTER CONSOLE BOX

○ : SPLICE POINTS

CODE	SEE PAGE	WIRE HARNESS WITH SPLICE POINTS	CODE	SEE PAGE	WIRE HARNESS WITH SPLICE POINTS
E11	22	COWL WIRE	B16	28	ROOF NO. 1 WIRE
I10	24		B17		
I12			B18		

