

# Clutch System

**GENERAL**

**CLUTCH SYSTEM**

CLUTCH COVER AND DISC  
CLUTCH PEDAL  
CLUTCH MASTER CYLINDER

# GENERAL

## SPECIFICATION EC11DECE

Item	SPECIFICATION
Clutch operation	Hydraulic type
Clutch disc	Single dry with diaphragm
Clutch cover assembly	Self Adjusting Clutch

## TIGHTENING TORQUE

Item	Nm	kgf.m	lb-ft
Clutch cover (6EA)	25~36	2.5~3.6	18.2~26.2
Clutch pedal bracket mounting	17~26	1.7~2.6	12.3~18.9
Oil chamber bolt	8~12	0.8~1.2	5.8~8.6
Connecting rod adjusting bolt	9~14	0.9~1.4	6.5~10.1
Clutch master cylinder mounting	17~26	1.7~2.6	12.3~18.8
Clutch switch nut	8~10	0.8~1.0	5.8~7.27
Clutch pedal bolt/nut	25~34	2.5~3.4	18.1~24.7
Ignition lock switch nut	8~10	0.8~1.0	5.8~7.27
C.S.C. assembly mounting nut	12~15	1.2~1.5	8.7~10.8

## SERVICE STANDARD

Item	Standard value [mm(in)]
Clutch pedal stroke	150~155 (5.90~6.10)
Clutch pedal free play	6~13 (0.24~0.51)

## SPECIAL TOOLS EE92F61C

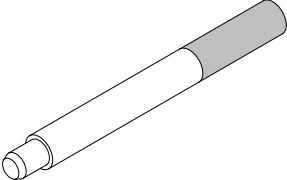
Tool (Number and Name)	Illustration	Use
09411-43000 Clutch disc guide	 <small>LOKG002A</small>	Installation of the clutch disc

# CLUTCH SYSTEM

**DESCRIPTION** EB27D04B

- To make up for this defect, the self adjusting clutch system makes the requested pedal pressure minimized so that makes the maintenance cycle longer.

**SELF ADJUSTING CLUTCH(S.A.C.) COVER**

- As a clutch disc facing is worn away according to its durability, a cover weight is increasing and a clutch pedal pressure can be more needed.

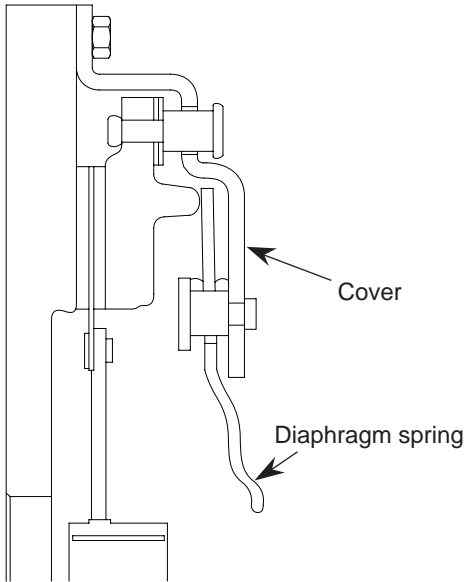
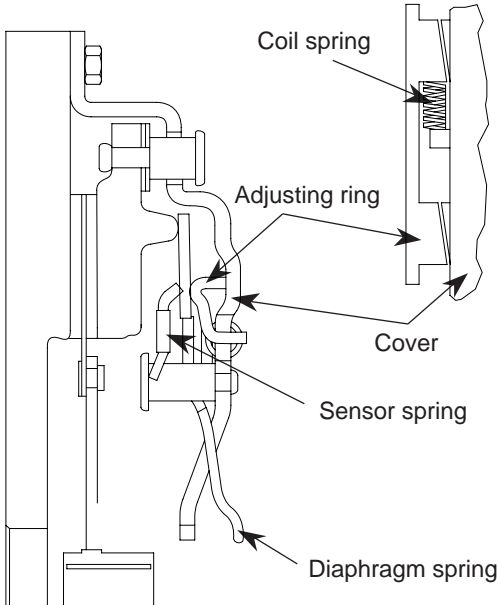
GENERAL CLUTCH COVER	SELF ADJUSTING CLUTCH COVER
 <p>Labels: Cover, Diaphragm spring</p>	 <p>Labels: Coil spring, Adjusting ring, Cover, Sensor spring, Diaphragm spring</p>
<p>· In a general clutch cover, the diaphragm spring increases the weight to the disc in proportion to abrasion.</p>	<p>· In a self adjusting clutch, the adjusting ring prevents the diaphragm spring from being raised to the transmission side in spite of abrasion.</p>

LOKG001A

**CONCENTRIC SLAVE CYLINDER-C.S.C.**

It improves working efficiency and lowers the number and the weight of part by unifying clutch release control parts(clutch release bearing ~ clutch release cylinder) in a manual transaxle.

**OPERATION** ECCA75CF

**CONCENTRIC SLAVE CYLINDER-C.S.C**

When the clutch pedal is pressed, oil pressure is transmitted along the arrow directions shown below and that moves the clutch slave cylinder and the diaphragm spring of the clutch cover.

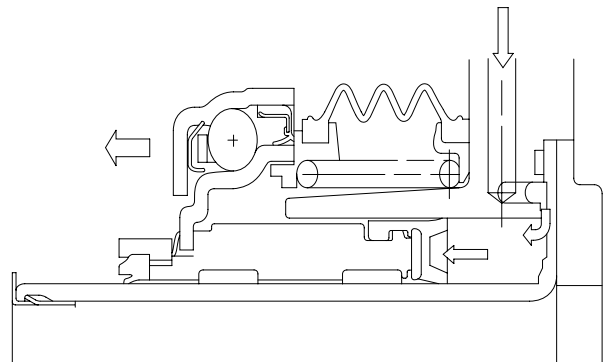

KORE001B

# CLUTCH COVER AND DISC

## COMPONENTS E501F1C7

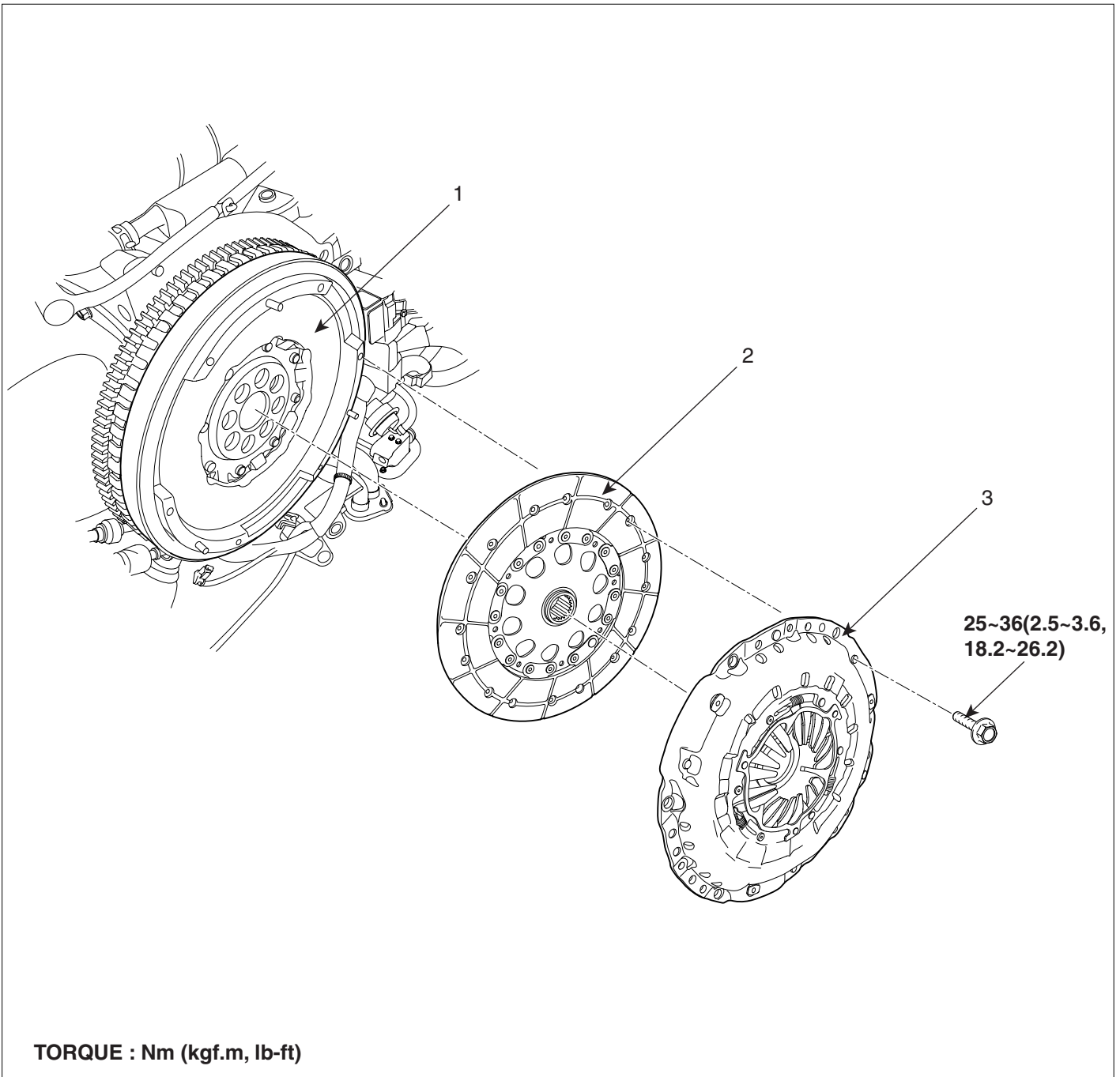

- 1. Engine flywheel
- 2. Clutch disc

- 3. Clutch cover

**REPLACEMENT** E879B1FB

1. Remove a transaxle assembly (refer to 'MT'-group).
2. Remove the clutch cover bolts. Not to be bent or twisted, loosen them in diagonal directions.

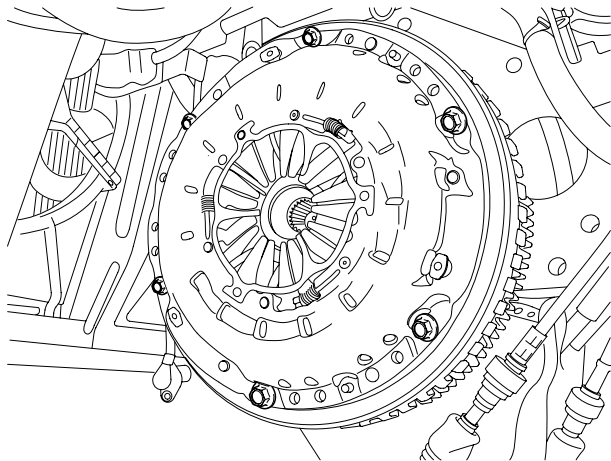

LOKG001D

3. Remove the clutch cover and disc.
4. Using the SST(09411-43000), install a clutch disc and cover.

**CAUTION**

- **Replace a clutch cover and disc as a set.**

**\* Possible problems when not following the caution**

- **When replacing only a disc, slip problem can occur because of the initial clamp load loss by the adjusting ring's unusual work.**
- **When replacing only a disc, it can be difficult to cut power because the thickness of the disc cannot be permitted.**

- **Apply grease on a disc spline part and transmission input shaft spline part as required.**

**\* Possible problems when not following**

- **When not applying: Excessively wear of splines and bad clutch operation**
- **When excessively applying: Scattered grease by centrifugal force contaminates the clutch disc. Loss of friction force can cause a slip**

- **The 'T/M SIDE' marked surface should face the transaxle.**

→ **If the surface face the opposite side, there can be an interference between a disc and a flywheel surface.**

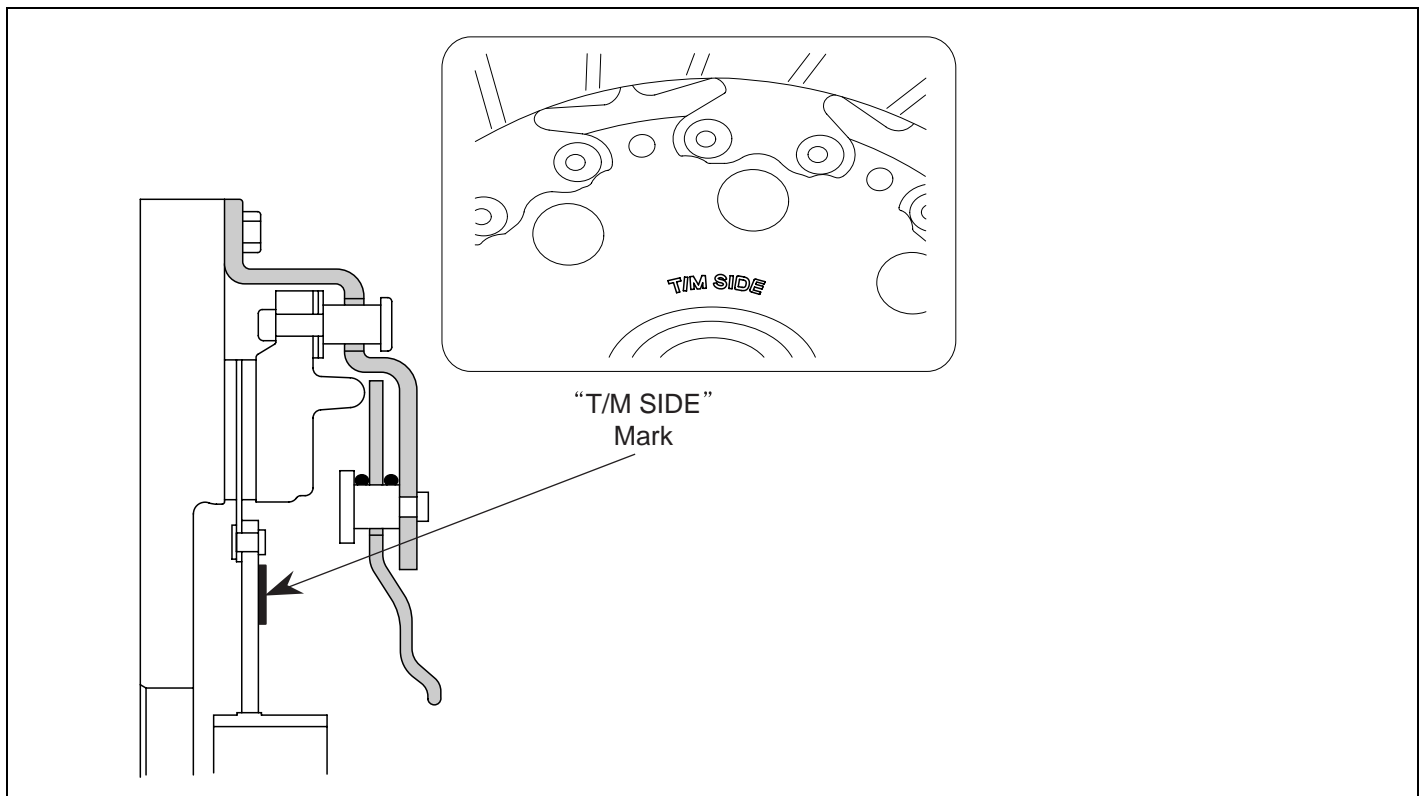

LOKG001E

5. Tighten the clutch cover.

---

**TORQUE:**  
 24.5~35.3Nm (2.5~3.6kgf.m, 18.1~26.0lb-ft) (6EA)

---

**CAUTION**

*When installing the clutch cover, tighten the bolts in diagonal directions not to be bent or twisted.*

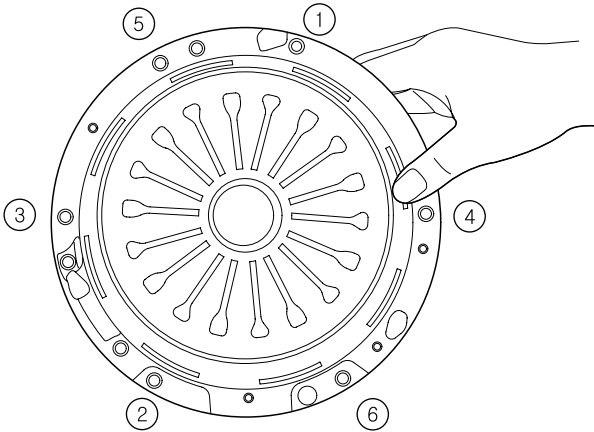

LOGG001F

**CAUTION**

- \* Possible problems when not following
- When tightening the bolt completely at a time: the clutch cover can be twisted and vibration can occur.
- On vehicles with self adjusting clutches, it is necessary to follow this caution.
- Not following tightening torque: There can be bad torque transmission in clutch and relaxation possibility of bolts.

**INSPECTION** EA41A5EB

1. Inspect diaphragm spring wear which is in contact with a concentric slave cylinder bearing.

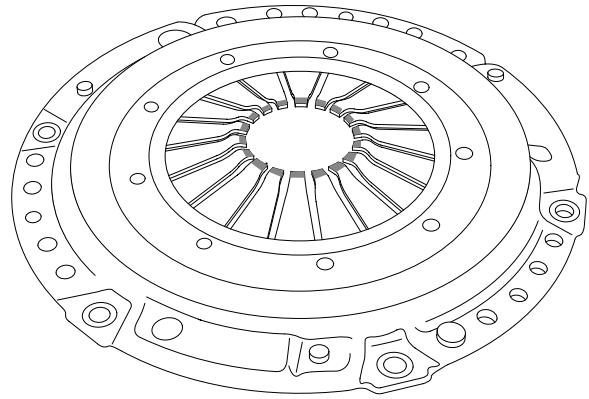

KORE002I

2. Check the clutch cover and disc surface for wear or crack.
3. Check the clutch disc lining for slipping or oil mark.
4. Measure the depth from a clutch lining surface to a rivet. If the measured value is less than the specification below, replace it.

---

Specification: 0.3mm(0.0118in)

---

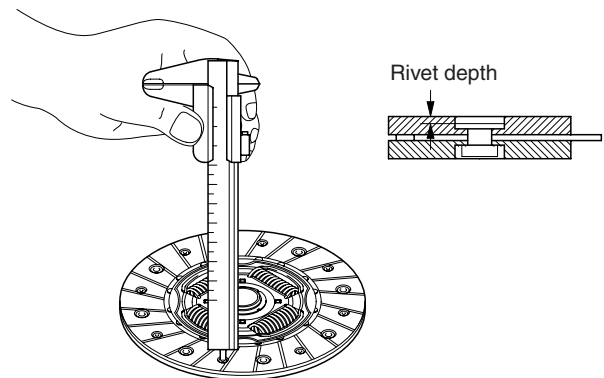

EORE002J

CLUTCH PEDAL

COMPONENTS EBB8432D

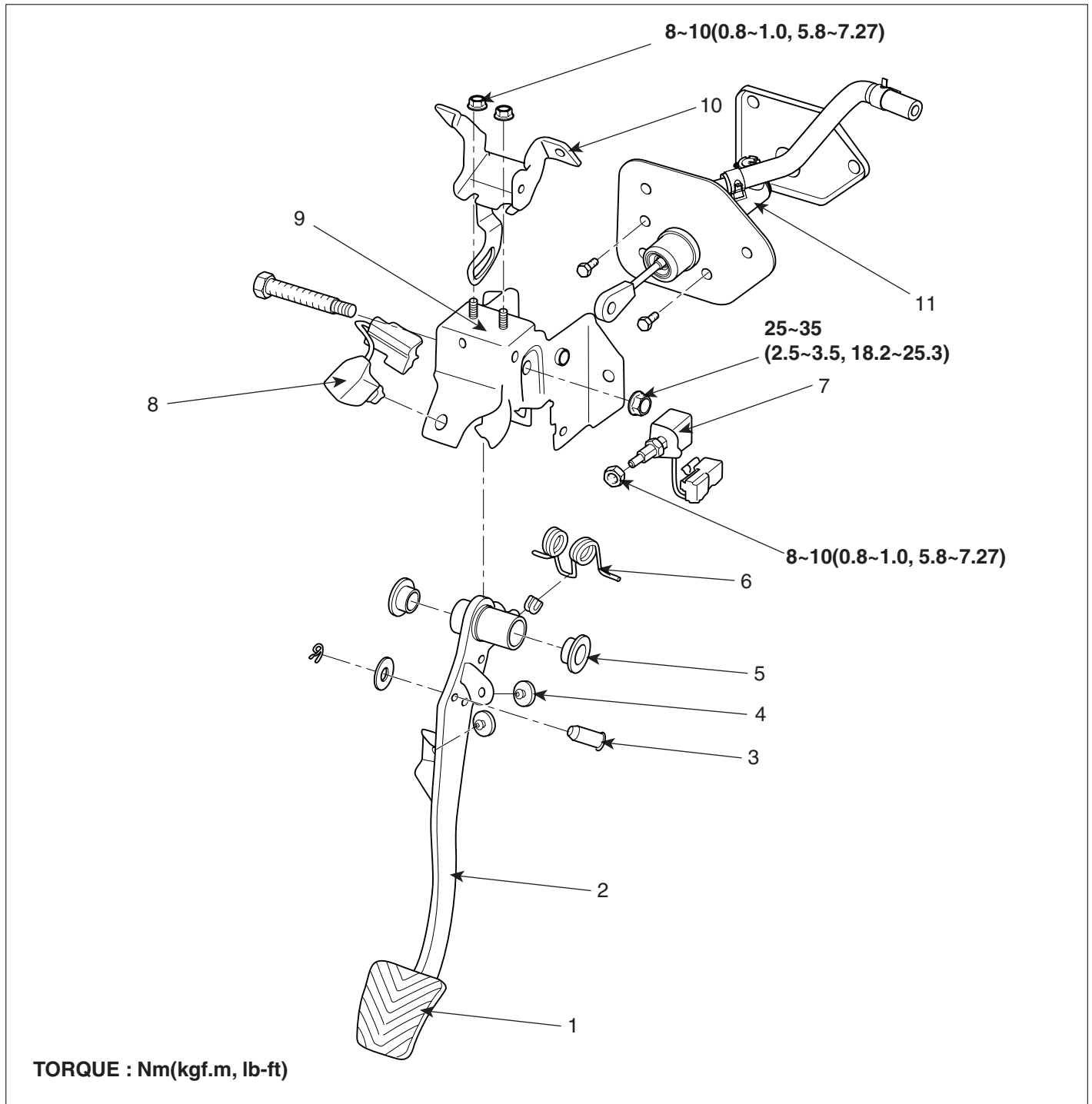

- |                        |                                     |
|------------------------|-------------------------------------|
| 1. Pedal pad           | 6. Turn over spring                 |
| 2. Clutch arm assembly | 7. Ignition lock switch             |
| 3. Self locking pin    | 8. Ignition lock switch             |
| 4. Stopper             | 9. Clutch member assembly           |
| 5. Bush                | 10. Cowl bracket assembly           |
|                        | 11. Clutch master cylinder assembly |

**REMOVAL** E9CFD3B5**NOTE**

*Do not spill brake fluid on the vehicle; it may damage the paint if brake fluid does contact the paint, wash it off immediately with water.*

1. Remove the brake fluid from the clutch master cylinder reservoir with a syringe.
2. Clamp the clutch master cylinder hose(A). If there is not enough room for clamping, you can also clamp the hose from the brake master cylinder side.

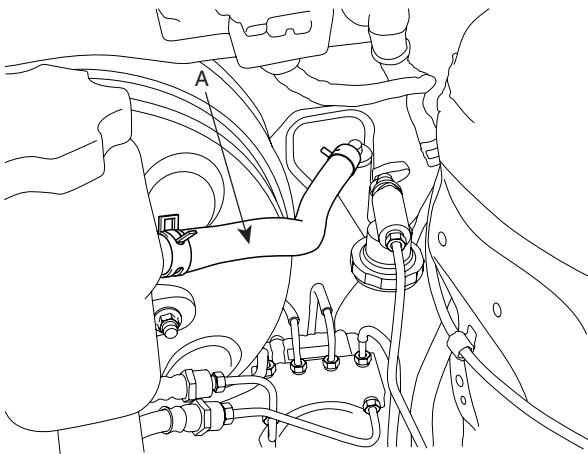
**[LHD]**

SCMCH6001D

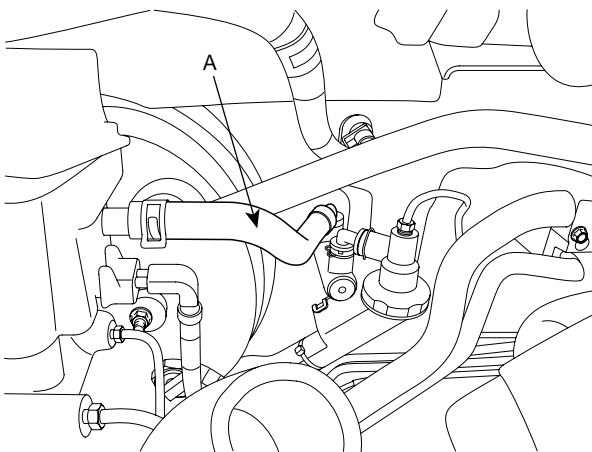
**[RHD]**

SCMCH6008L

3. Disconnect the hose(A) from the cylinder by releasing the clutch master cylinder clamp.

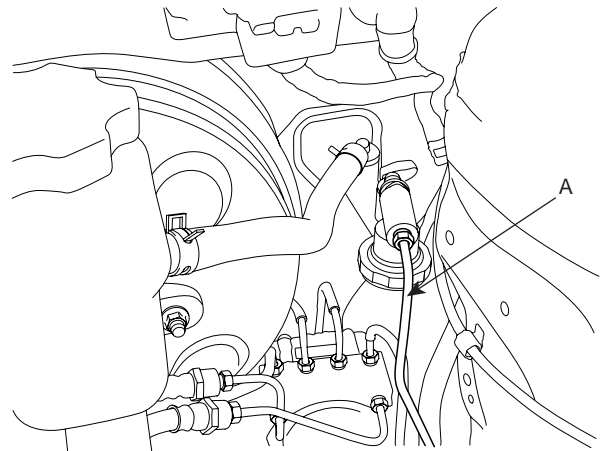
**[LHD]**

SCMCH6002D

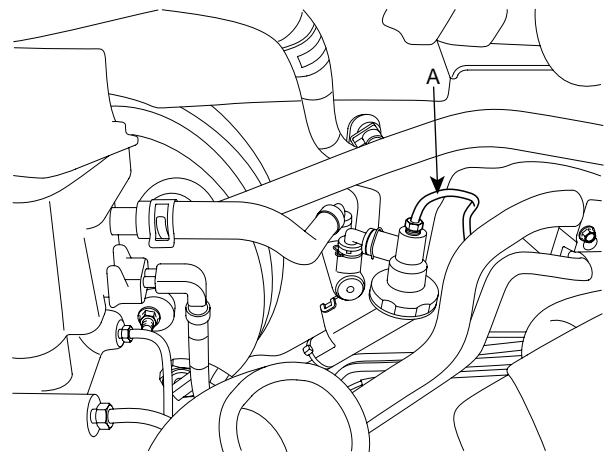
**[RHD]**

SCMCH6010L



4. Remove the ignition lock switch.
5. Remove the clutch pedal assembly mounting nuts (A-3ea) and bolt (B-2ea).

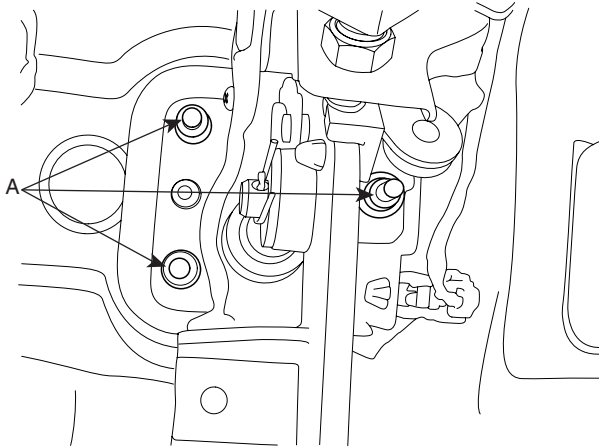

SCMCH6007D

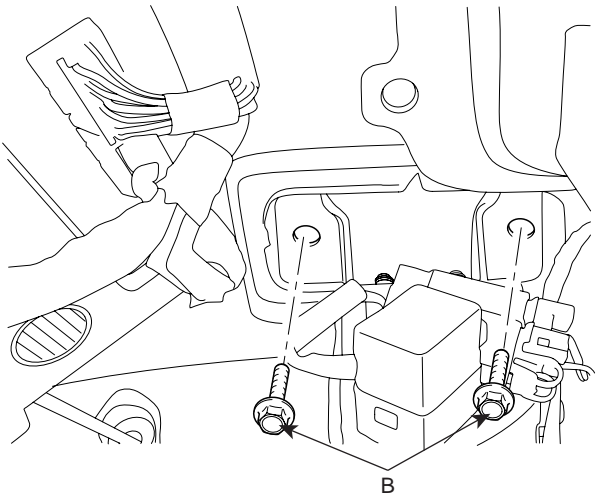

SCMCH6004D

6. Remove the clutch pedal and the master cylinder assembly together.

**INSTALLATION**

EA045E12

**NOTE**

- The clutch pedal and the clutch master cylinder are supplied as an assembly.
- Inspect the continuity of the ignition lock switch.
- Remove the floor mat before adjusting the clutch pedal.

1. Installation is in reverse order of removal.
2. Install a new one by tightening the bolts of the clutch pedal bracket.

**TORQUE :**

19~26 Nm(1.9~2.6 kgf.m, 13.8~18.9 lb-ft)

3. Bleed the air in C.S.C.(Concentric Slave Cylinder) system referring to ADJUSTMENT PROCEDURE.
4. Adjust the clutch pedal and the ignition lock switch.

**INSPECTION**

E5F8EBFA

**IGNITION LOCK SWITCH**

1. Disconnect 2P-connector from a ignition lock switch.
2. Disconnect the ignition lock switch. (if you can install a tester with the switch fixed, this step can be omissible)
3. Check for continuity between terminals. (refer to the table below)

Clutch pedal position	Ignition lock switch	Continuity
Released	Released	NO
Pressed	Pressed	YES

If there is difference between what tested and the table above, replace the ignition lock switch with a new one.

If not, install the ignition lock switch and adjust the clutch pedal.

**TORQUE :**

8~10Nm (0.8~1.0kgf.m, 5.8~7.2lb-ft)

## ADJUSTMENT PROCEDURE

E412CCDF

## CONCENTRIC SLAVE CYLINDER AIR BLEEDING PROCEDURE

1. After disconnecting a cap from the concentric slave cylinder air bleeder, insert a vinyl hose in the plug.
2. Loosening the plug screw, press and release the clutch pedal about 10 times.

**NOTE**

Hold the air bleeder body not to rotate with a spanner(A). The holding is needed when the plug loosened or tightened.

3. Tighten the plug during the clutch pedal pressed. Afterwards, raise the pedal with a hand.

## TORQUE :

25~29Nm (2.5~2.9Kgf.m, 18.2~21.1lb-ft)

4. After pressing the clutch pedal 3 times more, loosen the plug and retighten it with the pedal pressed. Raise it again, then.
5. Repeat the step 4 two or three times. (until there is no bubble in the fluid)

**CAUTION**

1. Do not clamp the pipe of a concentric slave cylinder.
2. Be careful not to damage O-rings.

## CLUTCH PEDAL AND IGNITION LOCK SWITCH

**NOTE**

- Inspect a ignition lock switch.
- Remove the driver's seat mat to adjust a clutch pedal.
- No gap between a clutch master cylinder piston and push rod can cause clutch slip.

1. Loosen and draw out the bolt until it is off the pedal surface.
2. Push and pull a clutch master cylinder push rod to satisfy the specification below.

## Specification [mm(in)]

Clutch pedal stroke(A) - 150~155(5.90~6.10)

Clutch pedal free play(B) - 6~13(0.24~0.51)

Clutch pedal distance(C) - 234.7(9.24)

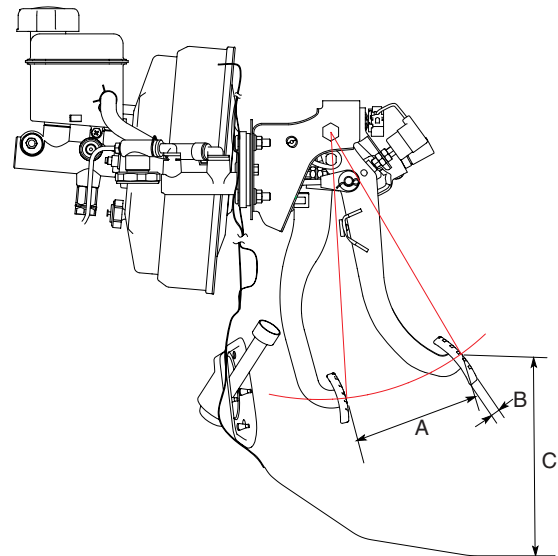

SCMCH6005D

3. With no pressure on a clutch pedal, tighten the bolt until it contacts on the pedal.
4. Fix the bolt with a nut.

## TORQUE :

14~20Nm (1.4~2.0kgf.m, 10.2~14.5lb-ft)

5. Press the clutch pedal to the seat ground.
6. Adjust the ignition lock switch position with the pedal a little(23~26mm) raised.
7. Install the ignition lock switch firmly.

---

**TORQUE:**

8~10Nm (0.8~1.0kgf.m, 5.8~7.2lb-ft)

---

**CLUTCH MASTER CYLINDER**

**COMPONENTS** EA99ED83

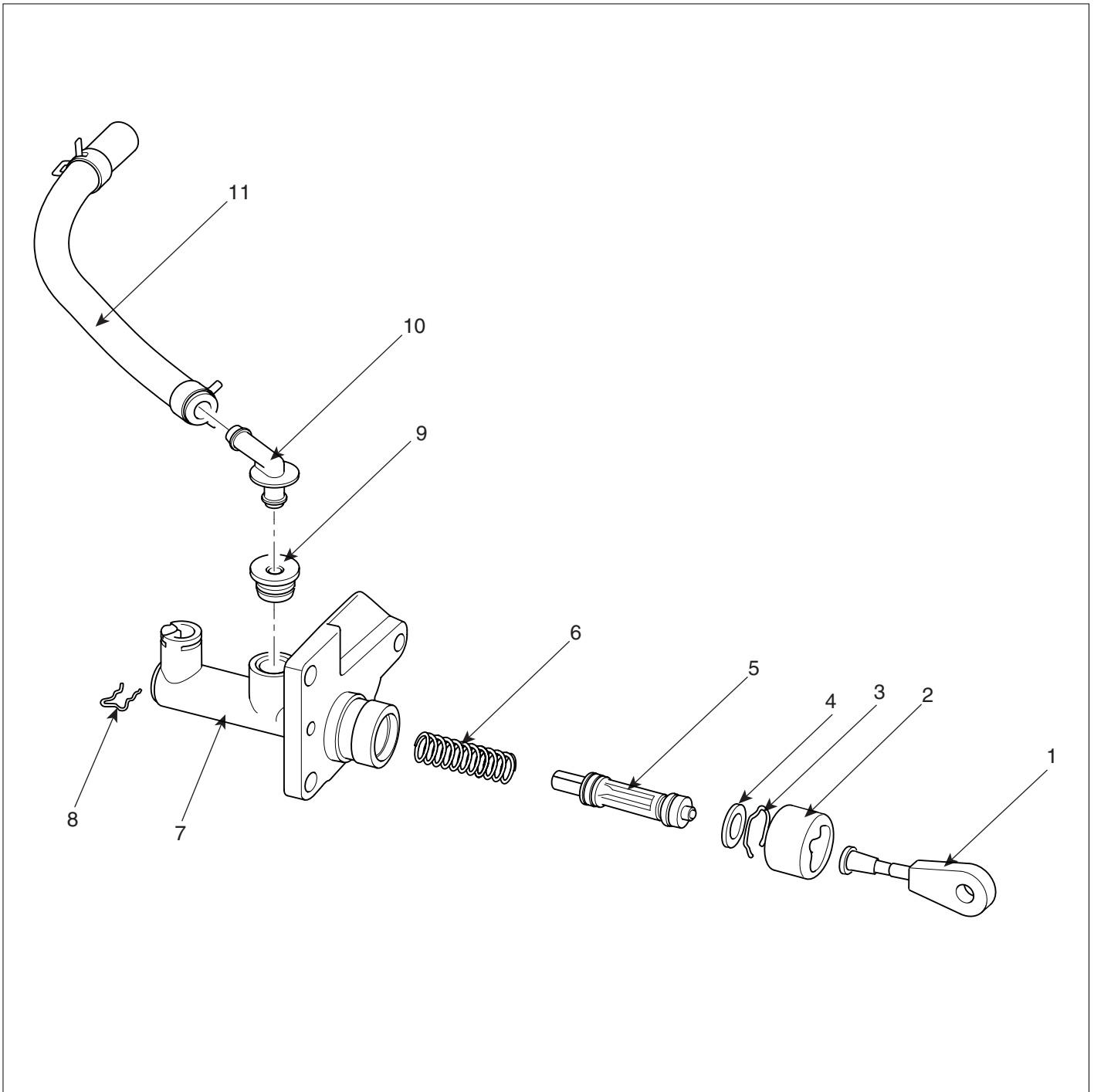

- |                    |                   |
|--------------------|-------------------|
| 1. Rod assembly    | 7. Body assembly  |
| 2. Boot            | 8. Clip           |
| 3. Key             | 9. Rubber         |
| 4. Plate           | 10. Nipple        |
| 5. Piston assembly | 11. Flexible hose |
| 6. Spring          |                   |