

# Emissions Control System

## **GENERAL**

### **CRANKCASE EMISSION CONTROL SYSTEM**

POSITIVE CRANKCASE VENTILATION (PCV) VALVE

### **EVAPORATIVE EMISSION CONTROL SYSTEM**

CANISTER  
PURGE CONTROL SOLENOID VALVE (PCSV)  
FUEL TANK AIR FILTER  
FUEL FILLER CAP

### **EXHAUST EMISSION CONTROL SYSTEM**

CONTINUOUS VARIABLE VALVE TIMING (CVVT)

## GENERAL

### DESCRIPTION ED0CA305

Components	Function	Remarks
Crankcase Emission System - Positive Crankcase Ventilation (PCV) valve	HC reduction	Variable flow rate type
Evaporative Emission System - Evaporative emission canister - Purge Control Solenoid Valve (PCSV)	HC reduction HC reduction	Duty control solenoid valve
Exhaust Emission System - MFI system (air-fuel mixture control device) - Three-way catalytic converter	CO, HC, NOx reduction CO, HC, NOx reduction	Heated oxygen sensor feedback type Monolithic type

### SPECIFICATIONS EF2996DD

#### PURGE CONTROL SOLENOID VALVE (PCSV)

▷ Specification

Item	Specification
Coil Resistance (Ω )	14.0 ~ 18.0 Ω [20°C (68°F)]

### TIGHTENING TORQUES E34D5DE1

Item	N-m	kgf-m	lbf-m
Positive Crankcase Ventilation Valve	8.0 ~ 12.0	0.8 ~ 1.2	6.0 ~ 8.0

### TROUBLESHOOTING E2236ADE

Symptom	Suspect area	Remedy
Engine will not start or hard to start	Vacuum hose disconnected or damaged	Repair or replace
	Malfunction of the Purge Control Solenoid Valve	Repair or replace
Rough idle or engine stalls	Vacuum hose disconnected or damaged	Repair or replace
	Malfunction of the PCV valve	Replace
	Malfunction of the evaporative emission canister purge system	Check the system; if there is a problem, check related components parts
Excessive oil consumption	Positive crankcase ventilation line clogged	Check positive crankcase ventilation system

COMPONENT LOCATION EB6479B1

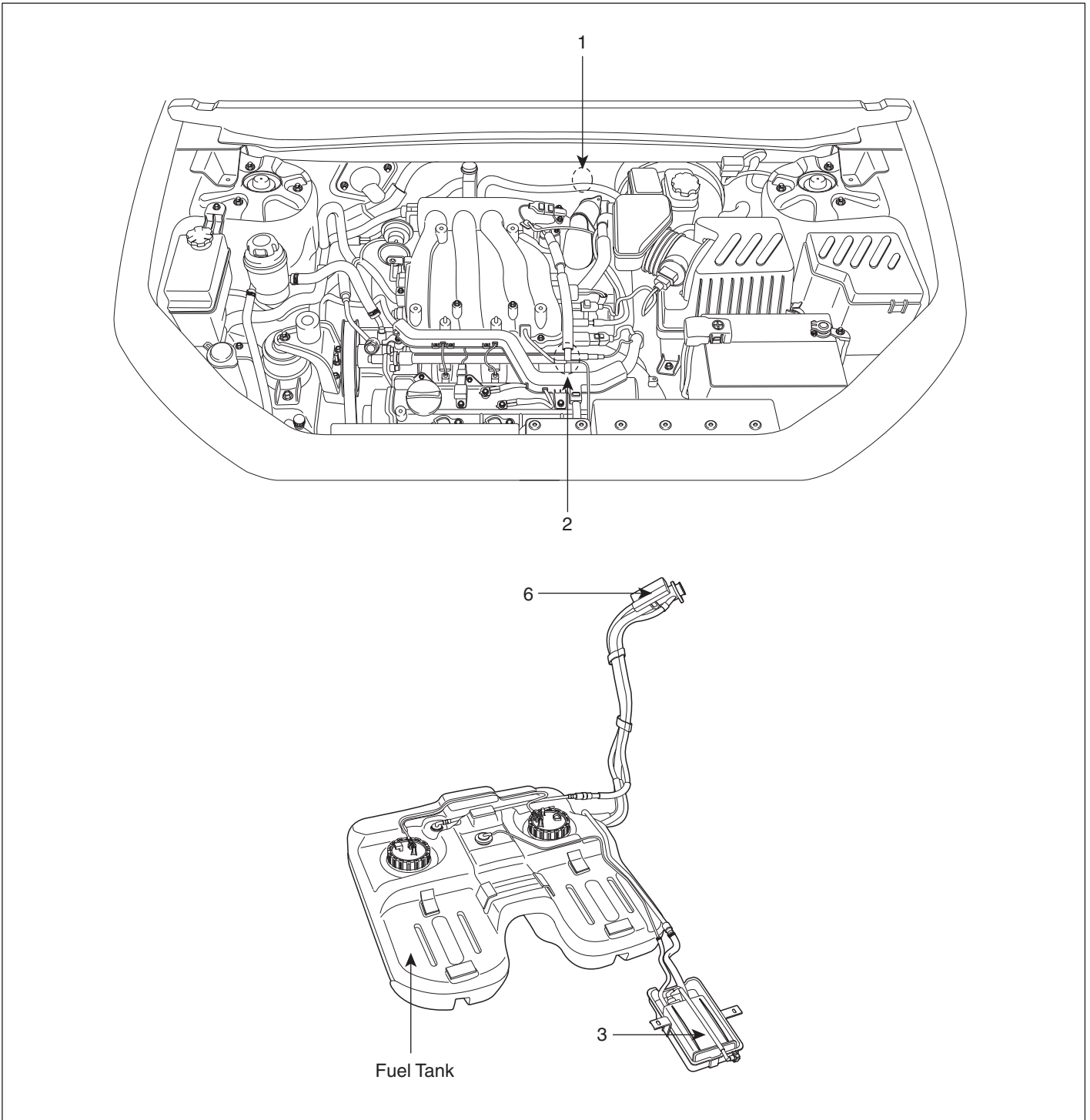

- 1. Purge Control Solenoid Valve (PCSV)
- 2. PCV Valve
- 3. Canister
- 4. Catalytic Converter (Bank 1)
- 5. Catalytic Converter (Bank 2)
- 6. Fuel Tank Air Filter

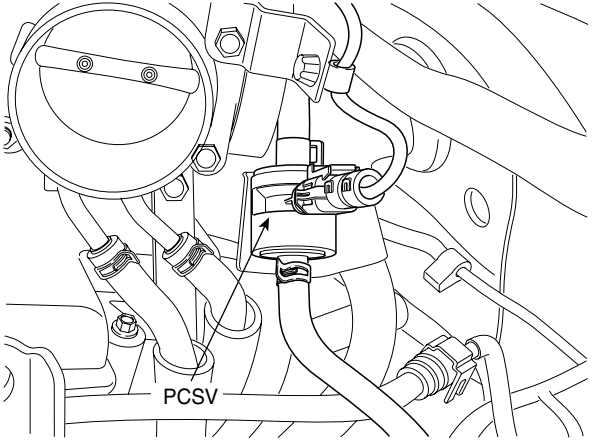
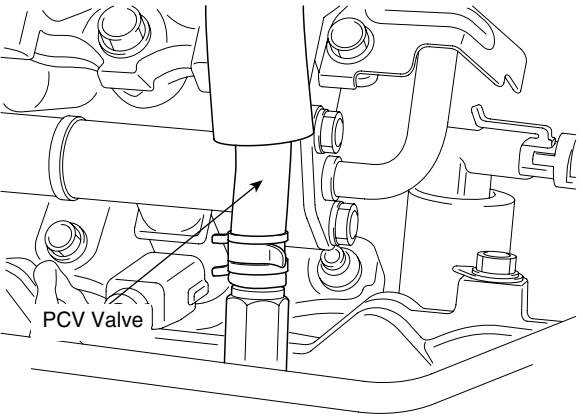
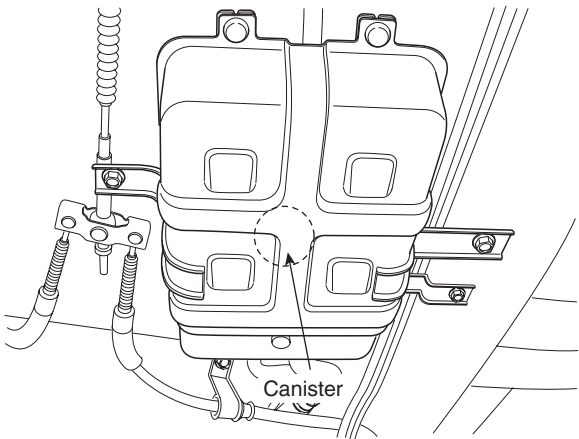
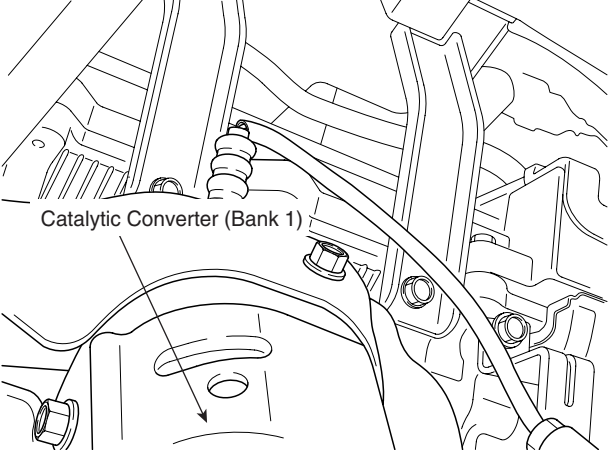
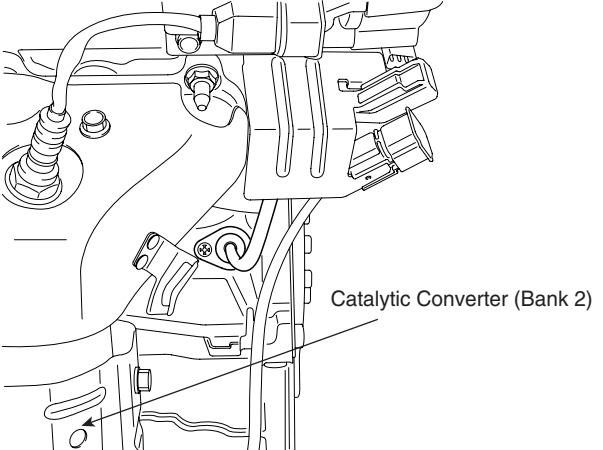
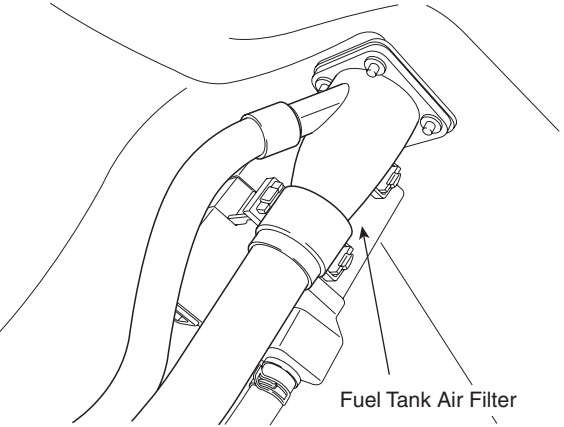
1	Purge Control Solenoid Valve (PCSV)	2	Positive Crankcase Ventilation (PCV) Valve
 <p style="text-align: right;">LGLG001L</p>		 <p style="text-align: right;">LELG001G</p>	
3	Canister	4	Catalytic Converter (Bank 1)
 <p style="text-align: right;">SCMEC6002L</p>		 <p style="text-align: right;">LELG001H</p>	
5	Catalytic Converter (Bank 2)	6	Fuel Tank Air Filter
 <p style="text-align: right;">LELG001I</p>		 <p style="text-align: right;">SCMEC6003L</p>	

**SCHEMATIC DIAGRAM**

E6C3F98F

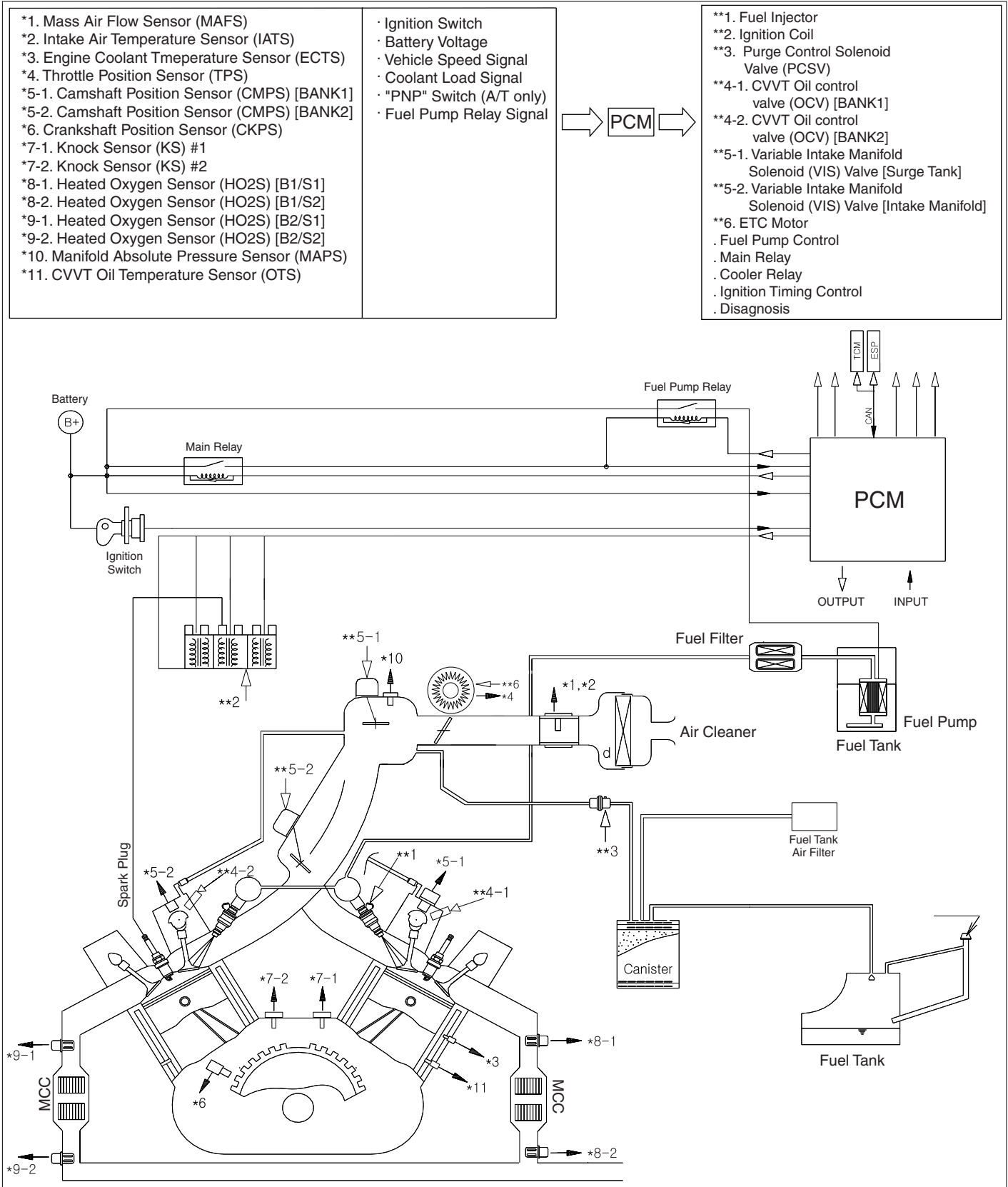

# CRANKCASE EMISSION CONTROL SYSTEM

## COMPONENTS EAB892E6

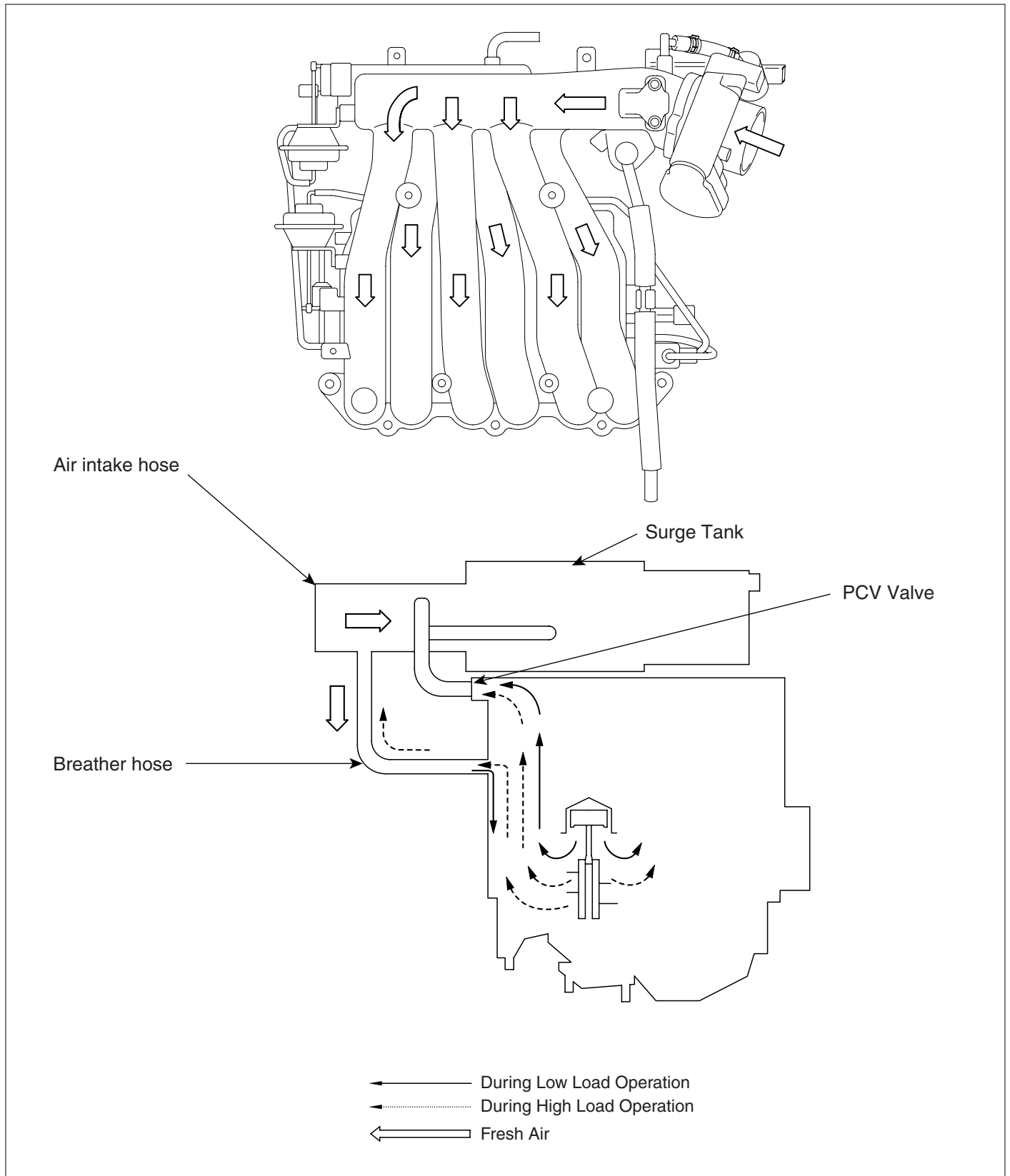

## INSPECTION EE69E0AE

1. Disconnect the ventilation hose from the positive crankcase ventilation (PCV) valve. Remove the PCV valve from the rocker cover and reconnect it to the ventilation hose.
2. Run the engine at idle and put a finger on the open end of the PCV valve and make sure that intake manifold vacuum can be felt.

### **NOTE**

*The plunger inside the PCV valve will move back and forth.*

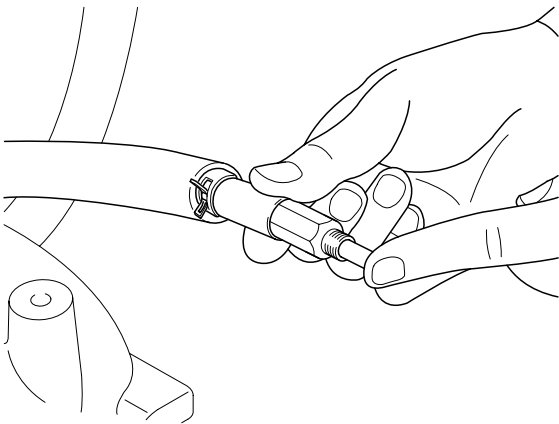

SCMEC6004L

# POSITIVE CRANKCASE VENTILATION (PCV) VALVE

## OPERATION EBB0DAB9

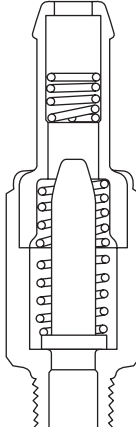
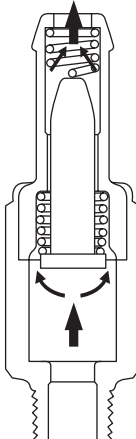
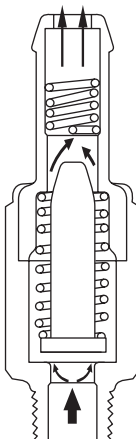
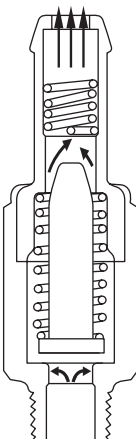
<p>Intake manifold side (No vacuum)</p>  <p>Rocker cover side</p> <p style="text-align: right;"><small>BEGE001S</small></p>		<p>Intake manifold side (High vacuum)</p>  <p>Rocker cover side</p> <p style="text-align: right;"><small>BEGE001T</small></p>	
Engine condition	Not running	Engine condition	Idling or decelerating
PCV valve	Not operating	PCV valve	Fully operating
Vacuum passage	Restricted	Vacuum passage	Small
<p>Intake manifold side (Moderate vacuum)</p>  <p>Rocker cover side</p> <p style="text-align: right;"><small>BEGE001U</small></p>		<p>Intake manifold side (Low vacuum)</p>  <p>Rocker cover side</p> <p style="text-align: right;"><small>BEGE001V</small></p>	
Engine condition	Normal operation	Engine condition	Accelerating and high load
PCV valve	Properly operating	PCV valve	Slightly operating
Vacuum passage	Large	Vacuum passage	Very large



**REMOVAL** EB3C969B

1. Disconnect the vacuum hose (A) and remove the PCV valve (B).

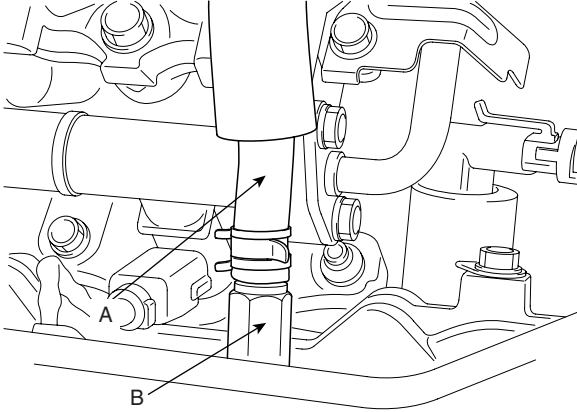

SCMEC6005L

**INSPECTION** EEDF42DC

1. Remove the PCV valve.
2. Insert a thin stick(A) into the PCV valve(B) from the threaded side to check that the plunger moves.
3. If the plunger does not move, the PCV valve is clogged. Clean it or replace.

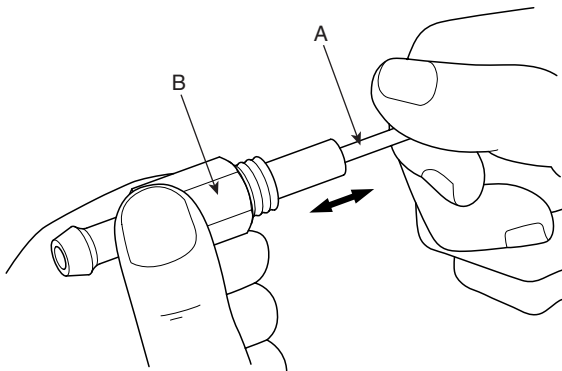

EERF600J

**INSTALLATION** E7FA321E

Install the PCV valve and tighten to the specified torque.

---

PCV Valve installation : 7.8 ~ 11.8 N·m (0.8  
~ 1.2 kgf·m, 5.8 ~ 8.7lbf·ft)

---

# EVAPORATIVE EMISSION CONTROL SYSTEM

## DESCRIPTION E4D6C1B7

Evaporative Emission Control System prevents fuel vapor stored in fuel tank from vaporizing into the atmosphere. When the fuel evaporates in the fuel tank, the vapor

passes through vent hoses or tubes to the canister filled with charcoal and the canister temporarily holds the vapor in the charcoal. If ECM determines to draw the gathered vapor into the combustion chambers during certain operating conditions, it will use vacuum in intake manifold to move it.

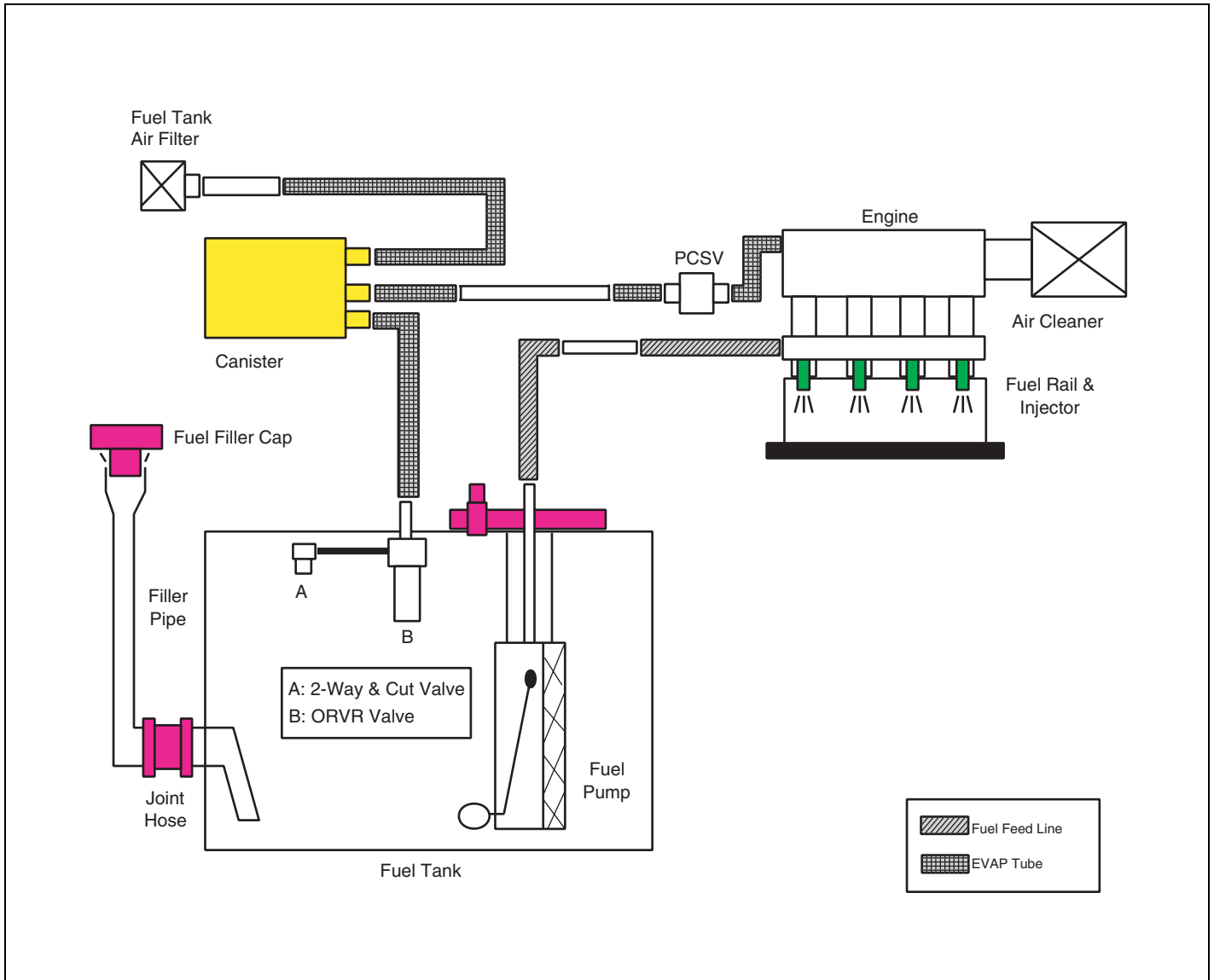

**CANISTER**

Canister is filled with charcoal and absorbs evaporated vapor in fuel tank. The gathered fuel vapor in canister is drawn into the intake manifold by the ECM/PCM when appropriate conditions are set.

**PURGE CONTROL SOLENOID VALVE (PCSV)**

Purge Control Solenoid Valve (PCSV) is installed in the passage connecting canister and intake manifold. It is a duty type solenoid valve and is operated by ECM/PCM signal. To draw the absorbed vapor into the intake manifold, the ECM/PCM will open the PCSV, otherwise the passage remains closed.

**FUEL FILLER CAP**

A ratchet tightening device on the threaded fuel filler cap reduces the chances of incorrect installation, which would seal the fuel filler. After the gasket on the fuel filler cap and the fill neck flange contact each other, the ratchet produces a loud clicking noise indicating the seal has been set.

**INSPECTION** E2BCDF9E

1. Disconnect the vacuum hose from the throttle body, and connect a vacuum pump to the vacuum hose.
2. Check the following points when the engine is cold [engine coolant temperature 60°C(140°F) or below] and when it is warm [engine coolant temperature 80°C(176°F) or higher].

**WHEN ENGINE IS COLD**

Engine operating condition	Applied vacuum	Result
Idling	50 kPa (7.3 psi)	Vacuum is held
3,000 rpm		

**WHEN ENGINE IS WARM**

Engine operating condition	Applied vacuum	Result
Idling	50 kPa (7.3 psi)	Vacuum is held
Within 3 minutes after engine start at 3,000 rpm	Try to apply vacuum	Vacuum is released
After 3 minutes have passed after engine start at 3,000 rpm	50 kPa (7.3 psi)	Vacuum will be held momentarily, after which, it will be released

# CANISTER

## REMOVAL E2209E60

1. Disconnect the vacuum hoses (A,B).

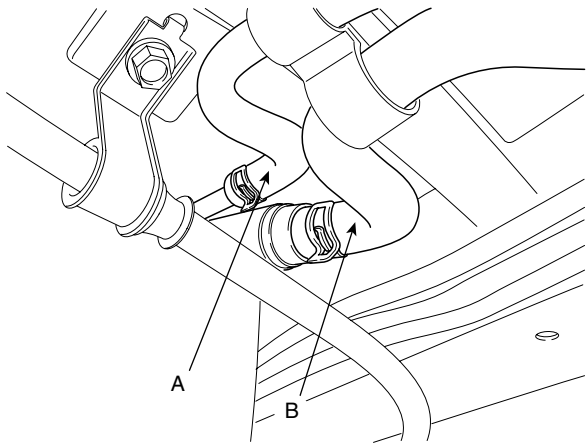

SCMEC6007L

2. Disconnect the vacuum hose quick-connector (A).

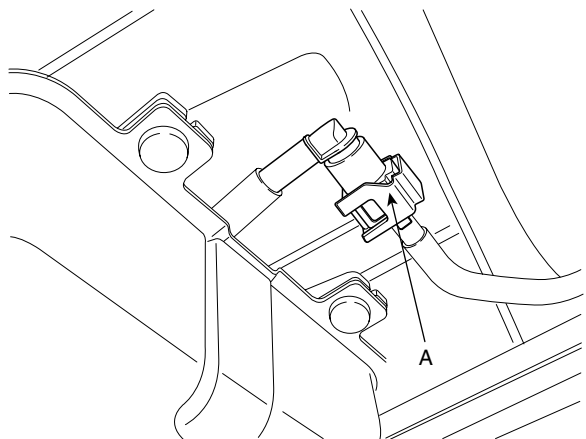

SCMEC6008L

3. Unscrew the mounting bolts (A) and remove the canister assembly (B) from the vehicle.

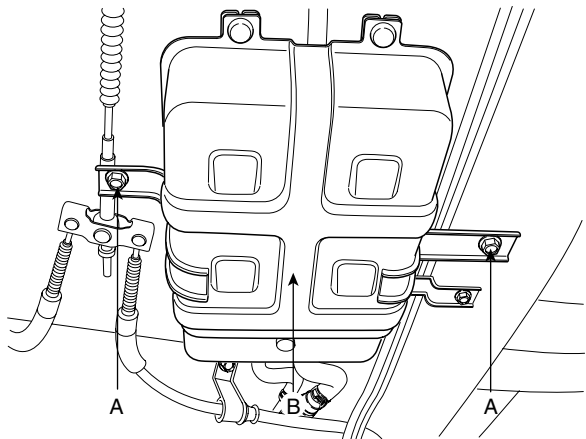

SCMEC6009L

## INSPECTION E84A19DD

1. Look for loose connections, sharp bends or damage to the fuel vapor lines.
2. Look for distortion, cracks or fuel damage.
3. After removing the canister, inspect for cracks, damage or saturated canister.

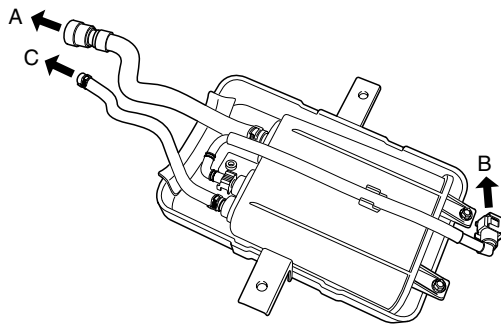

A : To Fuel Tank Air Filter  
 B : To Intake Manifold  
 C : To Fuel Tank

SCMEC6006L

## INSTALLATION EF0FCEBE

Install the canister according to the reverse order of "REMOVAL" procedure.

## PURGE CONTROL SOLENOID VALVE (PCSV)

### INSPECTION ECF3916E

#### **NOTE**

*When disconnecting the vacuum hose, make an identification mark on it so that it can be reconnected to its original position.*

1. Disconnect the vacuum hose from the solenoid valve.
2. Detach the harness connector.
3. Connect a vacuum pump to the nipple which is connected to intake manifold.
4. Apply vacuum and check when voltage is applied to the PCSV and when the voltage is discontinued.

<b>Battery voltage</b>	<b>Normal condition</b>
When applied	Vacuum is released
When discontinued	Vacuum is maintained

5. Measure the resistance between the terminals of the solenoid valve.

---

PCSV coil resistance( $\Omega$ ) : 14.0 ~ 18.0 $\Omega$  at 20°C (68°F)

---

## FUEL TANK AIR FILTER

### REPLACE EDCFC370

1. Remove the rear left wheel house inner cover (Refer to "BD" Group in this WORKSHOP MANUAL).
2. Disconnect the hose (A) connected with the canister and remove the fuel tank air filter (B) from the filler-neck assembly (C).

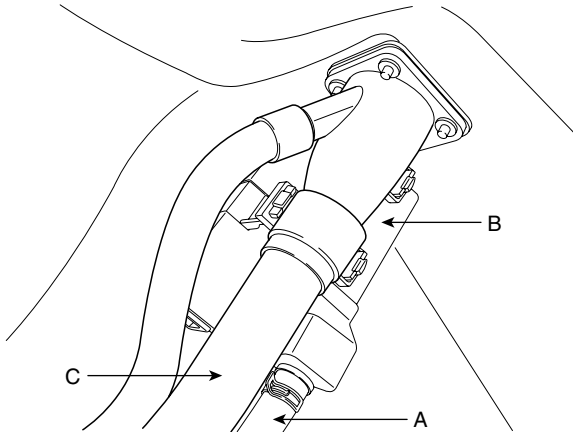

SCMEC6010L

# FUEL FILLER CAP

## DESCRIPTION EDD25DE3

A ratchet tightening device on the threaded fuel filler cap reduces the chances of incorrect installation, which would

seal the fuel filler. After the gasket on the fuel filler cap and the filler neck flange contact each other, the ratchet produces a loud clicking noise indicating the seal has been set.

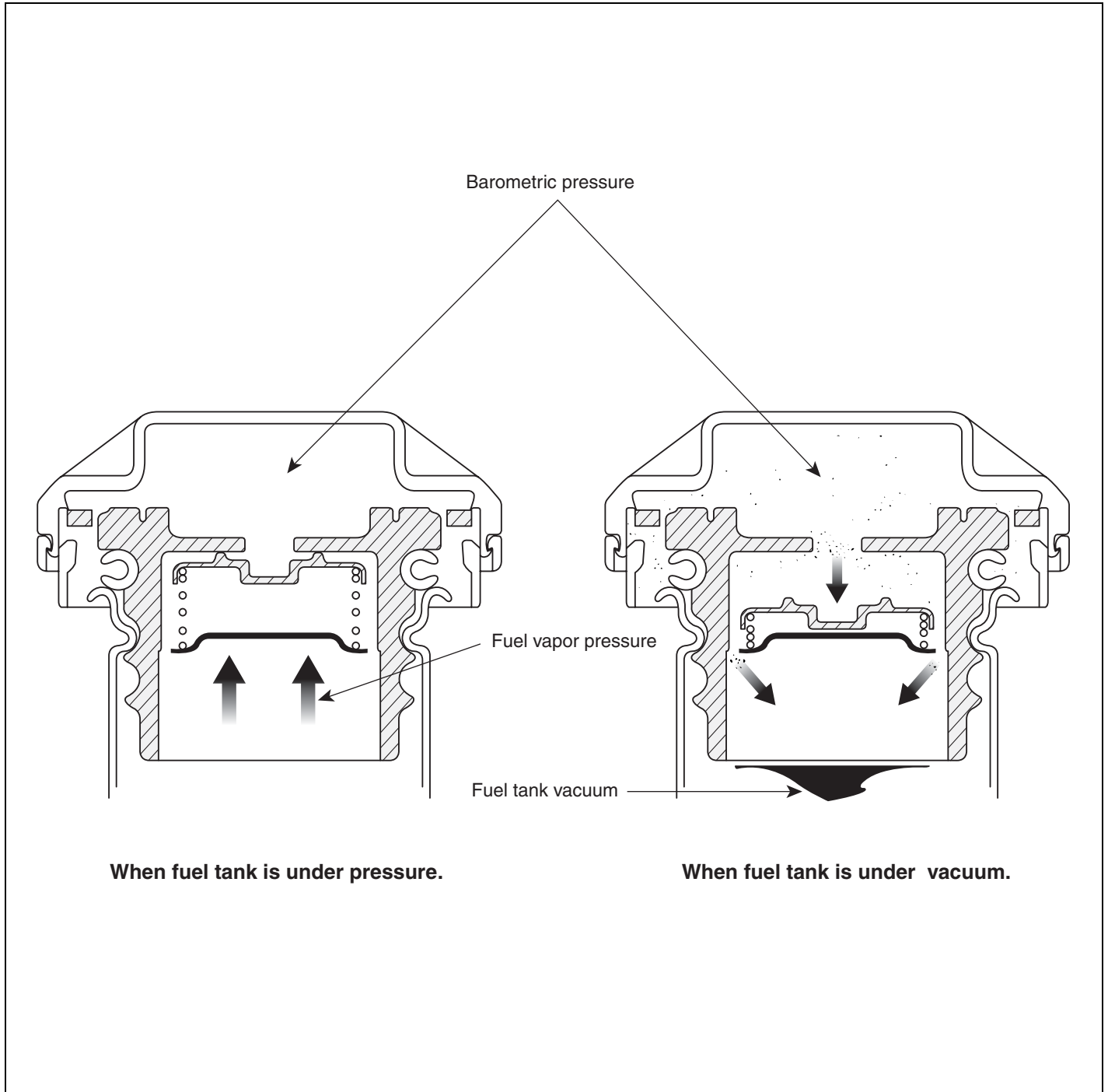

# EXHAUST EMISSION CONTROL SYSTEM

## DESCRIPTION EBA45808

Exhaust emissions (CO, HC, NOx) are controlled by a combination of engine modifications and the addition of special control components.

Modifications to the combustion chamber, intake manifold, camshaft and ignition system form the basic control system.

These items have been integrated into a highly effective system which controls exhaust emissions while maintaining good driveability and fuel economy.

### **AIR/FUEL MIXTURE CONTROL SYSTEM [MULTIPOINT FUEL INJECTION (MFI) SYSTEM]**

The MFI system is a system which uses the signals from the heated oxygen sensor to activate and control the injector installed in the manifold for each cylinder, thus precisely regulating the air/fuel mixture ratio and reducing emissions.

This in turn allows the engine to produce exhaust gases of the proper composition to permit the use of a three way catalyst. The three way catalyst is designed to convert the three pollutants (1) hydrocarbons (HC), (2) carbon monoxide (CO), and (3) oxides of nitrogen (NOx) into harmless substances. There are two operating modes in the MFI system.

1. Open Loop air/fuel ratio is controlled by information programmed into the ECM.
2. Closed Loop air/fuel ratio is adjusted by the ECM based on information supplied by the oxygen sensor.



# CONTINUOUS VARIABLE VALVE TIMING (CVVT)

## DESCRIPTION ECBE8ABD

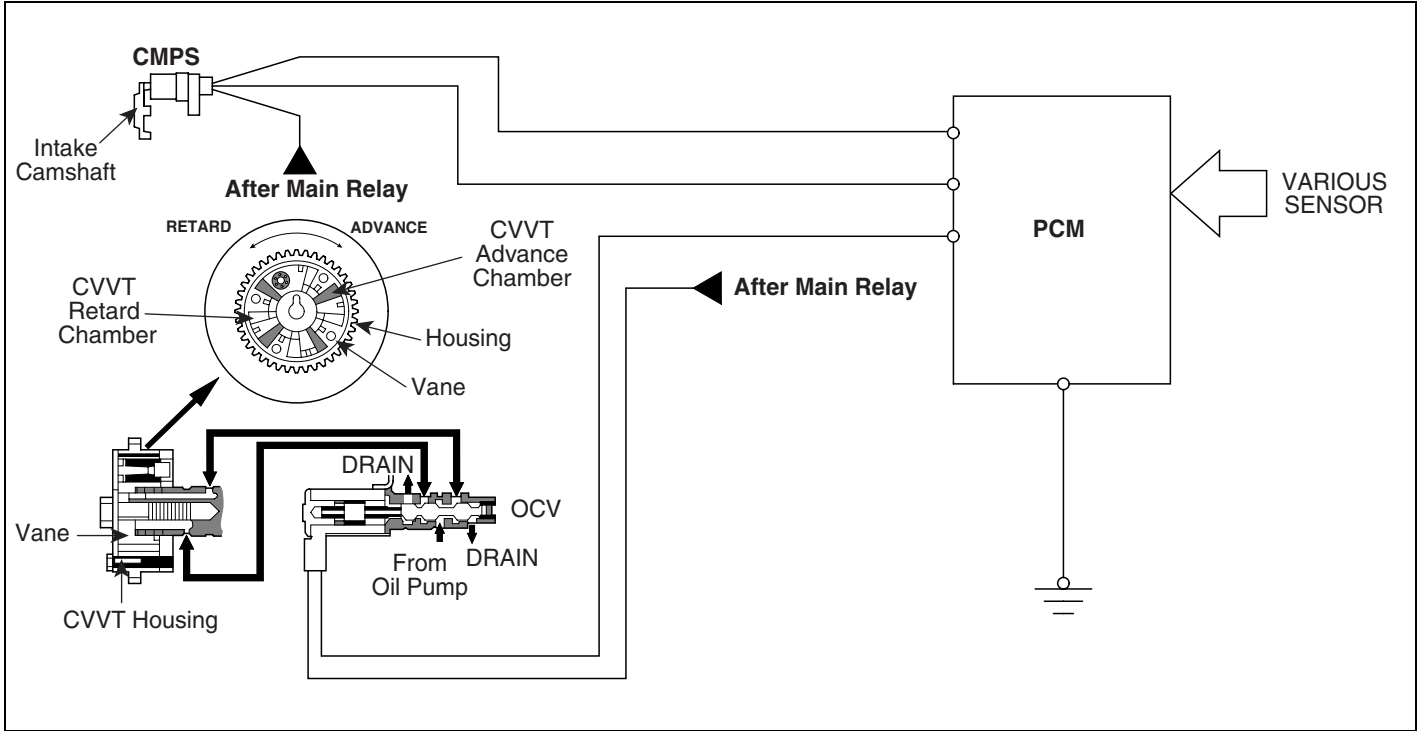

UEBG013A

The CVVT (Continuously Variable Valve Timing) which is installed on the exhaust camshaft controls intake valve open and close timing in order to improve engine performance. The intake valve timing is optimized by CVVT system depending on engine rpm.

This CVVT system improves fuel efficiency and reduces NOx emissions at all levels of engine speed, vehicle speed, and engine load by EGR effect because of valve over-lap optimization. The CVVT changes the phase of the intake camshaft via oil pressure. It changes the intake valve timing continuously.

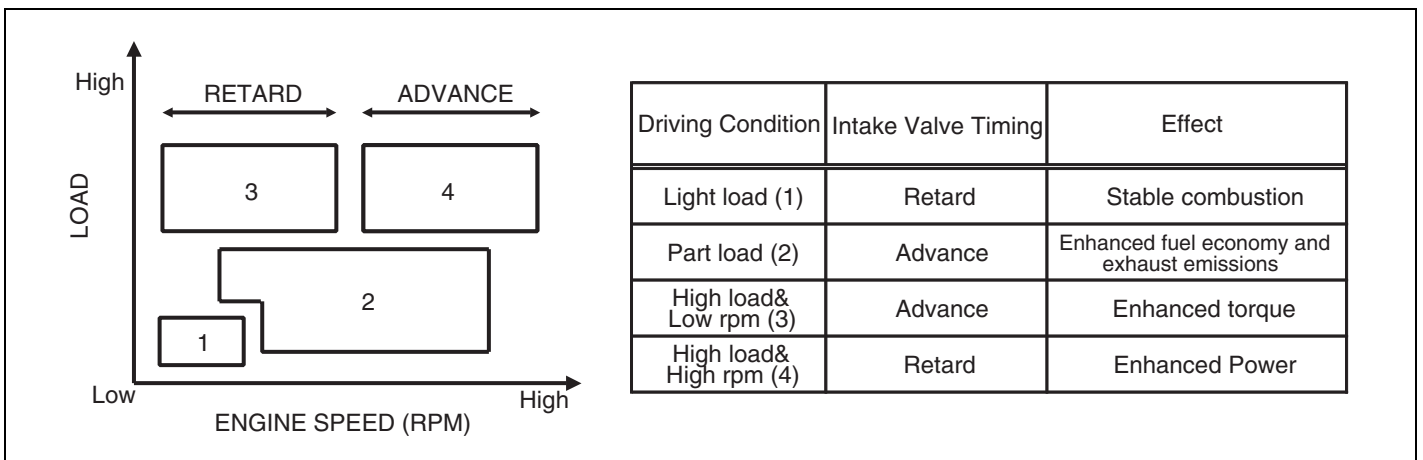

LEIF001Q

## OPERATION EA7ECA2

The CVVT system makes continuous intake valve timing changes based on operating conditions.

Intake valve timing is optimized to allow the engine to produce maximum power. Cam angle is advanced to obtain the EGR effect and reduce pumping loss. The intake valve is closed quickly to

reduce the entry of the air/fuel mixture into the intake port and improve the changing effect. Reduces the cam advance at idle, stabilizes combustion, and reduces engine speed.

If a malfunction occurs, the CVVT system control is disabled and the valve timing is fixed at the fully retarded position.

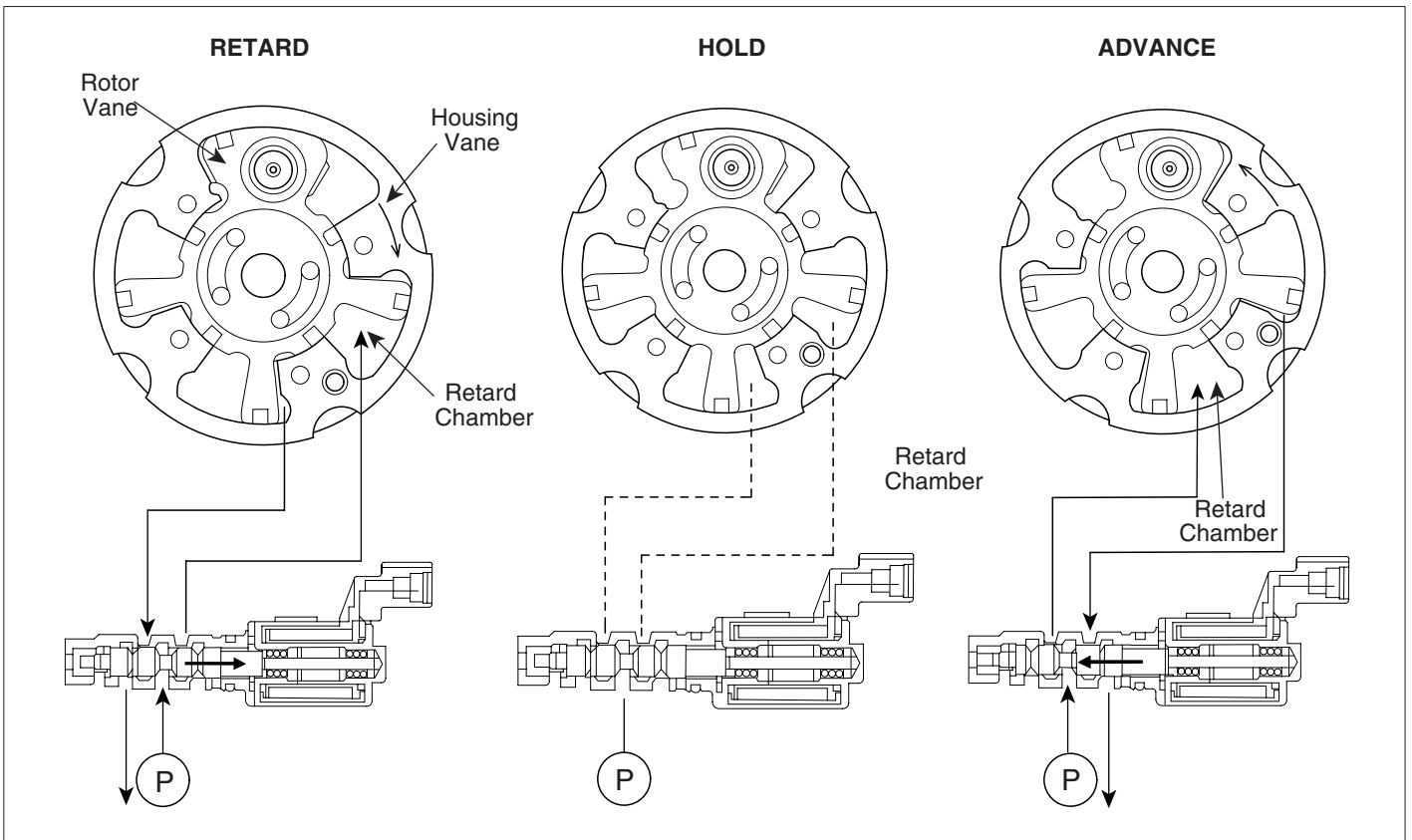
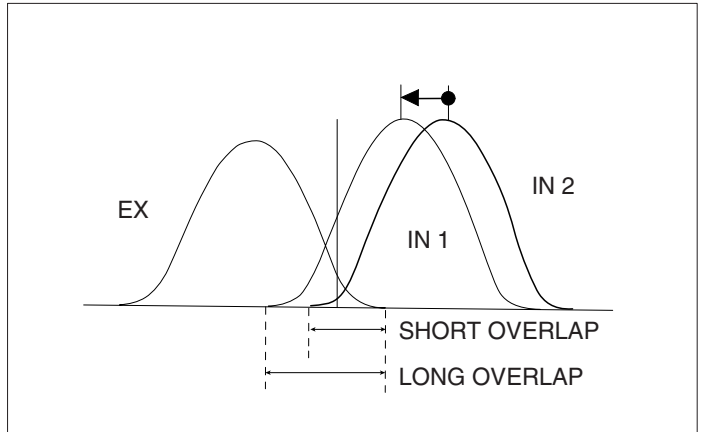
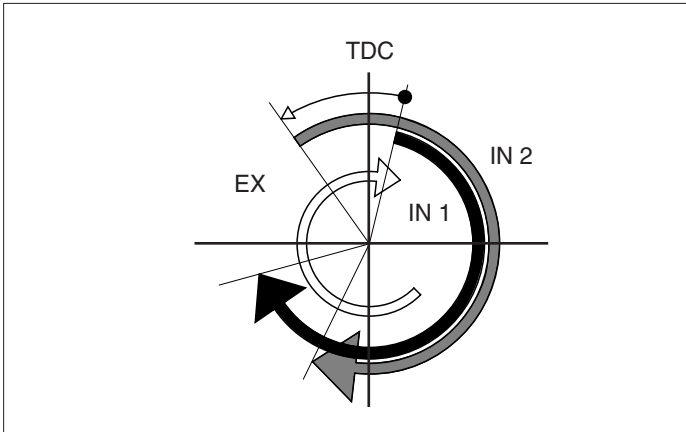

UEBG014A

1. The above figure shows the relative operation structures of the housing vane to the rotor vane.
2. If the CVVT is held a certain control angle, to hold this state, oil is replenished as much as oil leaks from the oil pump.

Be sure there might be a difference in the position according to the engine running state (rpm, oil temperature, and oil pressure).

The OCV (Oil-flow Control Valve) spool location at this time is as follows.

**Oil pump → Advance oil chamber (Little by little open the inflow side to the advance oil chamber) → Almost close the drain side**