

General Information

GENERAL

GENERAL

IDENTIFICATION NUMBER

LOCATIONS EB9D3DCB

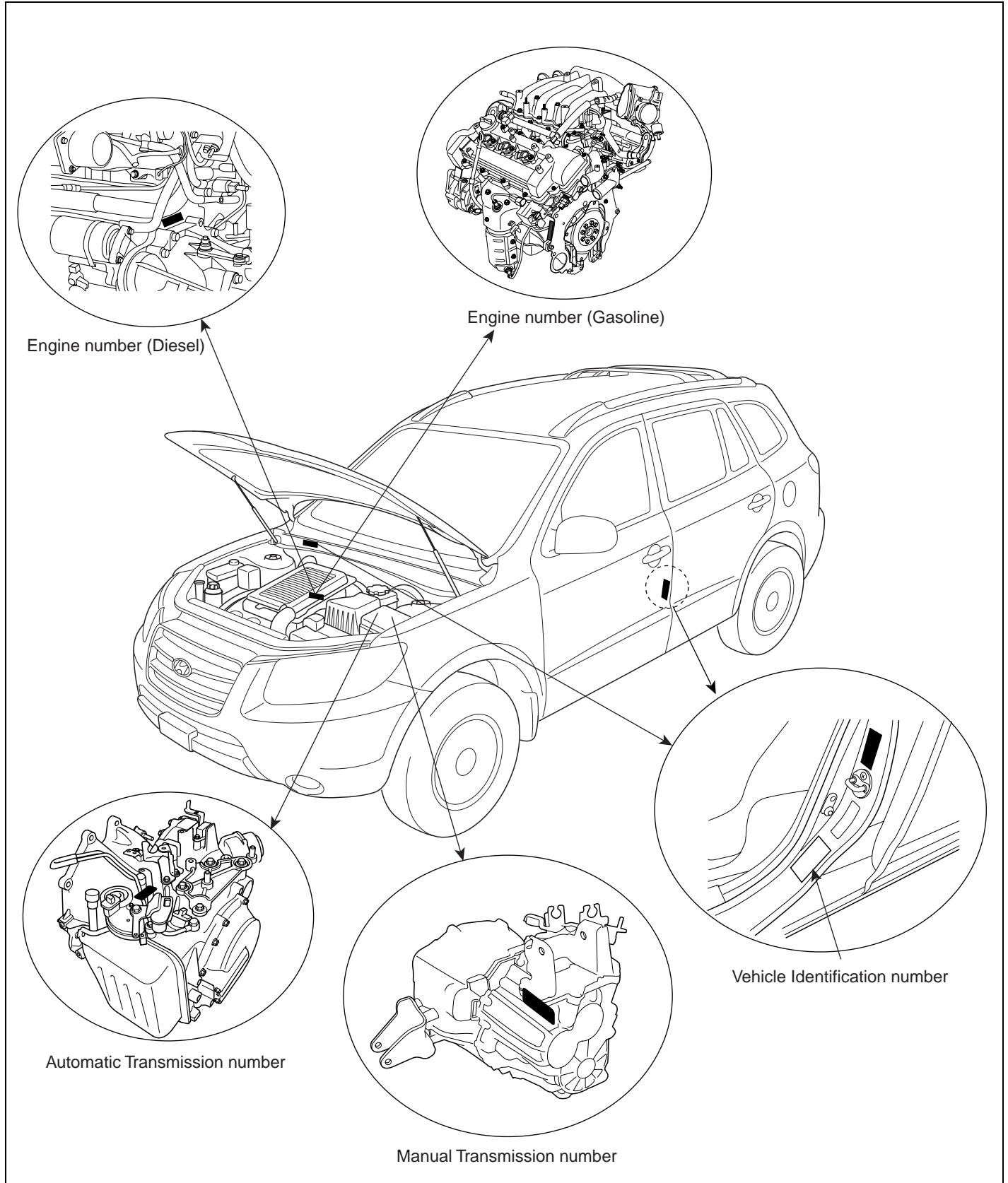

IDENTIFICATION NUMBER DESCRIPTION

VEHICLE IDENTIFICATION NUMBER

K M H S F 8 2 D P 4 U 000001
 | | | | | | | | | | | |
 1 2 3 4 5 6 7 8 9 10 11 12

SCMG16002L

1. Geographic zone
- K : Korea
2. Manufacturer
- M : Hyundai motor company
3. Vehicle type
- H : Passenger
4. Vehicle line
- S : SANTAFE
5. Model & Series
- F : STANDAD (L)
- G : DELUXE (GL)
- H : SUPER DELUXE (GLS)
- J : GRAND SALON (GDS)
- K : SUPPER GRAND SALON (HGS)
6. Body type
- 8 : WAGON
7. Restraint system
- 0 : Both side - None
- 1 : Both side - Active belt
- 2 : Both side - Passive belt
8. Engine type
- D : Gosoline 2.7 DOHC
- W : Diesel 2.2 TCI
9. Check digit
- Check digit : 0 ~ 9, x
- P : Left hand driver
- R : Right hand driver
10. Production year
- 5 : 2005, 6 : 2006, 7 : 2007
11. Plant of production
- U : Ulsan (korea)
12. Vehicle production sequence number
- 000001 ~ 999999

PAINT CODE

CODE	COLOR
NW	Noble White
EB	Ebony Black
LS	Smart Silver
3M	Vanilla White
5Q	Blue Onyx
5J	Superior Red
6F	Blue Titanium
6M	Platinum Silver
2Z	Black Pearl
2J	Gunmental
5T	Satin Beige

ENGINE IDENTIFICATION NUMBER

G 6 E A 5 000001
 | | | | | |
 1 2 3 4 5 6

KABF201A

1. Engine fuel
- G : Gasoline
- D : Diesel
2. Engine range
- 4 : 4 cycle 4 cylinder
- 6 : 4 cycle 6 cylinder
- 3~4 : Engine development order and capacity
- EB : D-engine TCI, 2188cc (Diesel)
- EA : μ -engine, 2656cc (Gasoline)
5. Production year
- 5 : 2005, 6 : 2006, 7 : 2007
6. Engine production sequence number
- 000001 ~ 999999

TRANSMISSION IDENTIFICATION NUMBER

AUTOMATIC

MANUAL

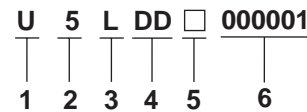
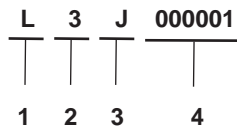

SCMGI6004D

EAQF103A

1. Model
 - S : M5GF2
2. Production year
 - 5 : 2005, 6 : 2006, 7 : 2007
3. Gear ratio
 - D : 5.071 / 3.737
4. Transaxle production sequence number
 - 000001 ~ 999999

1. Mode
 - U : A5HF1
2. Production year
 - 5 : 2005, 6 : 2006, 7 : 2007
3. Gear ratio
 - L : 3.684
4. Detailed classification
 - DD : 4WD
 - CD : 2WD
 - ED : 2WD + LSD

AUTOMATIC



5. Spare
6. Transaxle production sequence number
 - 000001 ~ 999999

SCMGI6004L

1. Model
 - T : F4A51-3
2. Production year
 - 5 : 2005, 6 : 2006, 7 : 2007
3. Gear ratio
 - S : 4.520
4. Detailed classification
 - DD : 4WD
 - CD : 2WD
 - ED : 2WD + LSD
5. Spare
6. Transaxle production sequence number
 - 000001 ~ 999999

WARNING / CAUTION LABEL LOCATIONS

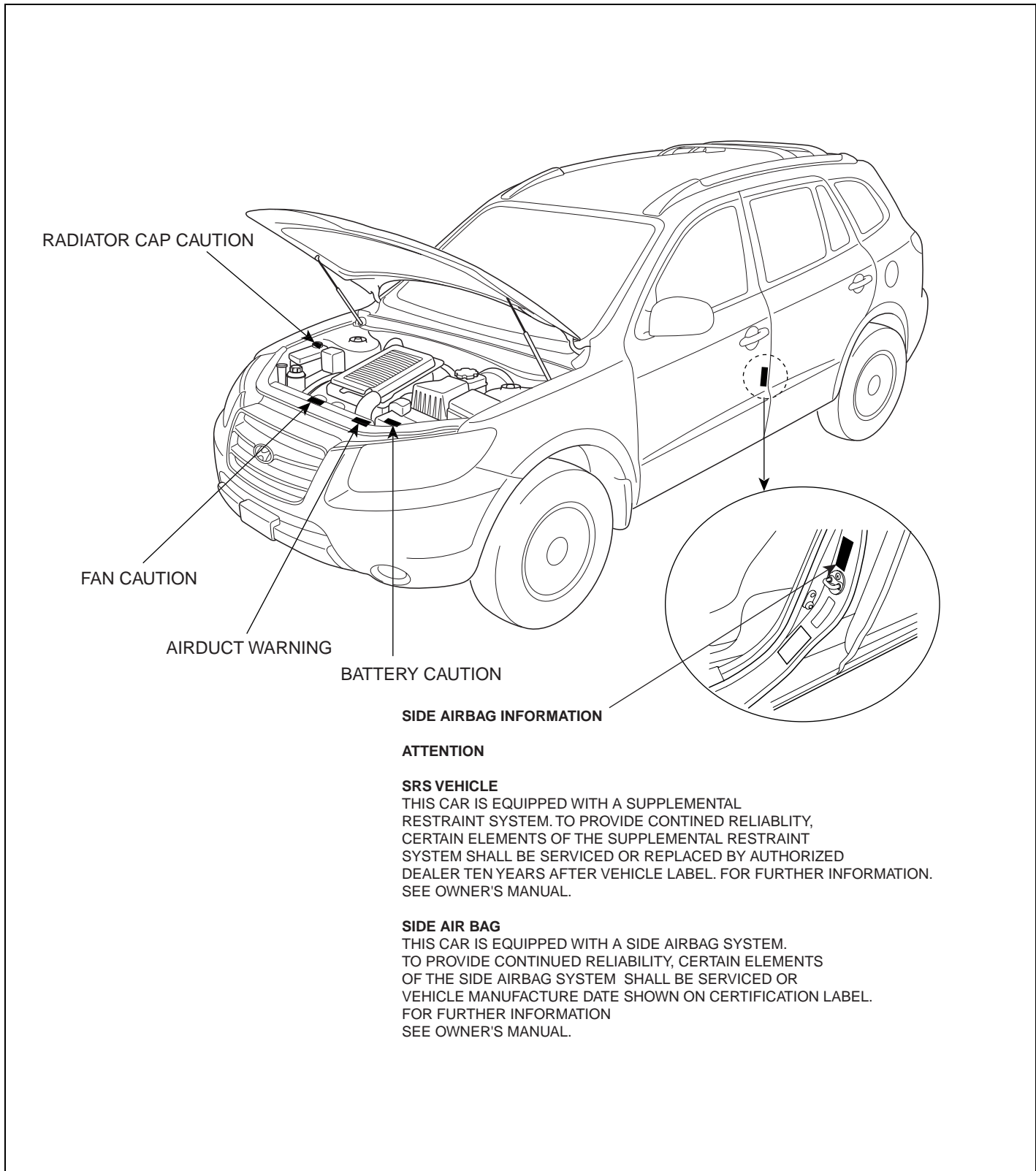

SIDE AIRBAG INFORMATION

ATTENTION

SRS VEHICLE

THIS CAR IS EQUIPPED WITH A SUPPLEMENTAL RESTRAINT SYSTEM. TO PROVIDE CONTINUED RELIABILITY, CERTAIN ELEMENTS OF THE SUPPLEMENTAL RESTRAINT SYSTEM SHALL BE SERVICED OR REPLACED BY AUTHORIZED DEALER TEN YEARS AFTER VEHICLE LABEL. FOR FURTHER INFORMATION. SEE OWNER'S MANUAL.

SIDE AIR BAG

THIS CAR IS EQUIPPED WITH A SIDE AIRBAG SYSTEM. TO PROVIDE CONTINUED RELIABILITY, CERTAIN ELEMENTS OF THE SIDE AIRBAG SYSTEM SHALL BE SERVICED OR REPLACED BY AUTHORIZED DEALER TEN YEARS AFTER VEHICLE MANUFACTURE DATE SHOWN ON CERTIFICATION LABEL. FOR FURTHER INFORMATION. SEE OWNER'S MANUAL.

AIR BAG WARNING / CAUTION LABEL

CAUTION

AIR BAG : Handling is limited to trained personnel.
To be used only in prescribed vehicles. If not properly installed, device may become a dangerous projectile.
See service manual instruction

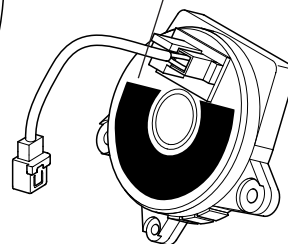
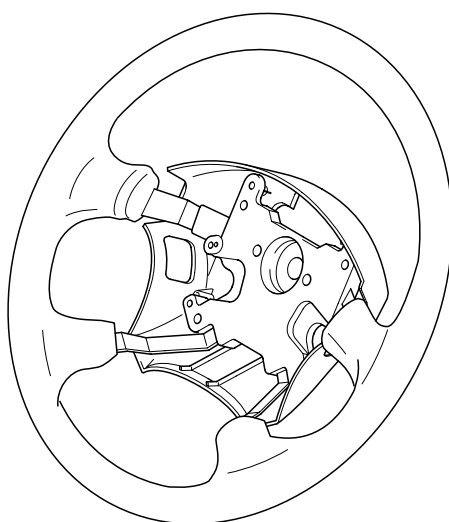
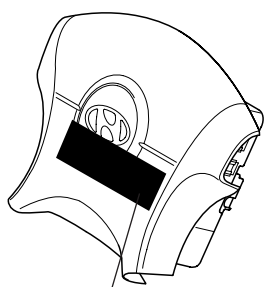
**DRIVE MODULE CAUTION****Caution**

Don't open, remove or transfer to another vehicle. Risk of malfunction and bodily injury!

This unit is to be installed and/or dismantled by trained personnel only. This item contains an explosive to be installed igniter.

AIR BAG WARNING / CAUTION LABEL (CONT'D)

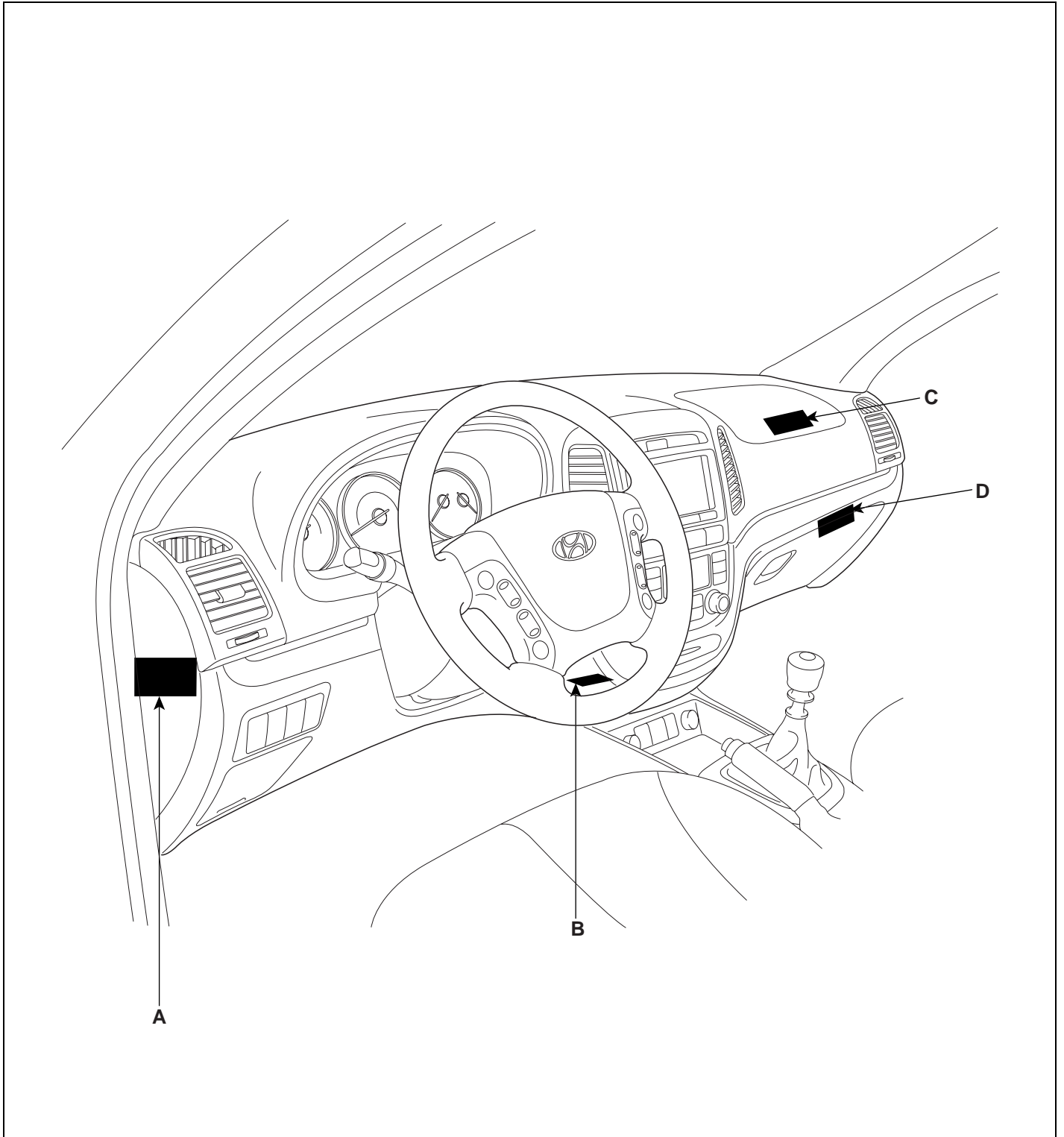

WARNING / CAUTION LABEL (CONT'D)**A : WARNING**

SEE OWNER'S MANUAL.

This car is equipped a side airbag for each front seat.

- Do not use any accessory seat covers.
- Use of other seat covers could reduce the effect of the system.
- Do not install any accessories on the side or near the side airbag.
- Do not use excessive force on the side of the seat.
- For further information, see the owner's manual.

B : CAUTION

AIRBAG ESPE UNIT

Detach connector before unmounting. Assemble strictly according to manual instructions.

C : PASSENGER MODULE CAUTION**CAUTION**

Don't open, remove or transfer to another vehicle.

Risk of malfunction and bodily injury!

This unit is to be installed and/or dismantled by trained personnel only. This item contains an explosive to be installed igniter.

D : SUPPLEMENTAL RESTRAINT SYSTEM (AIRBAG) INFORMATION

- The airbag is a Supplement Restraint System (SRS).
You must always wear the seat belts.
- The airbag system condition is normal when the "SRS" lamp in the cluster flashes approximately 6 times after the ignition key is turned on and then goes off.
- If any of the following condition occur, the system must be serviced.
 - "SRS" lamp does not light up when the key is turned on.
 - "SRS" lamp stays lit or flashes continuously.
 - The airbag has inflated.
- The airbag system must be inspected by an authorized dealer ten years after the vehicle manufacture date shown on the certification label, located on left front door opening area.

WARNING

Failure to the above instructions may result in injury to you or other occupants in the vehicle

- See the "SRS" section in Owner's Manual for more information about airbags.

BATTERY CAUTION LABEL DESCRIPTION

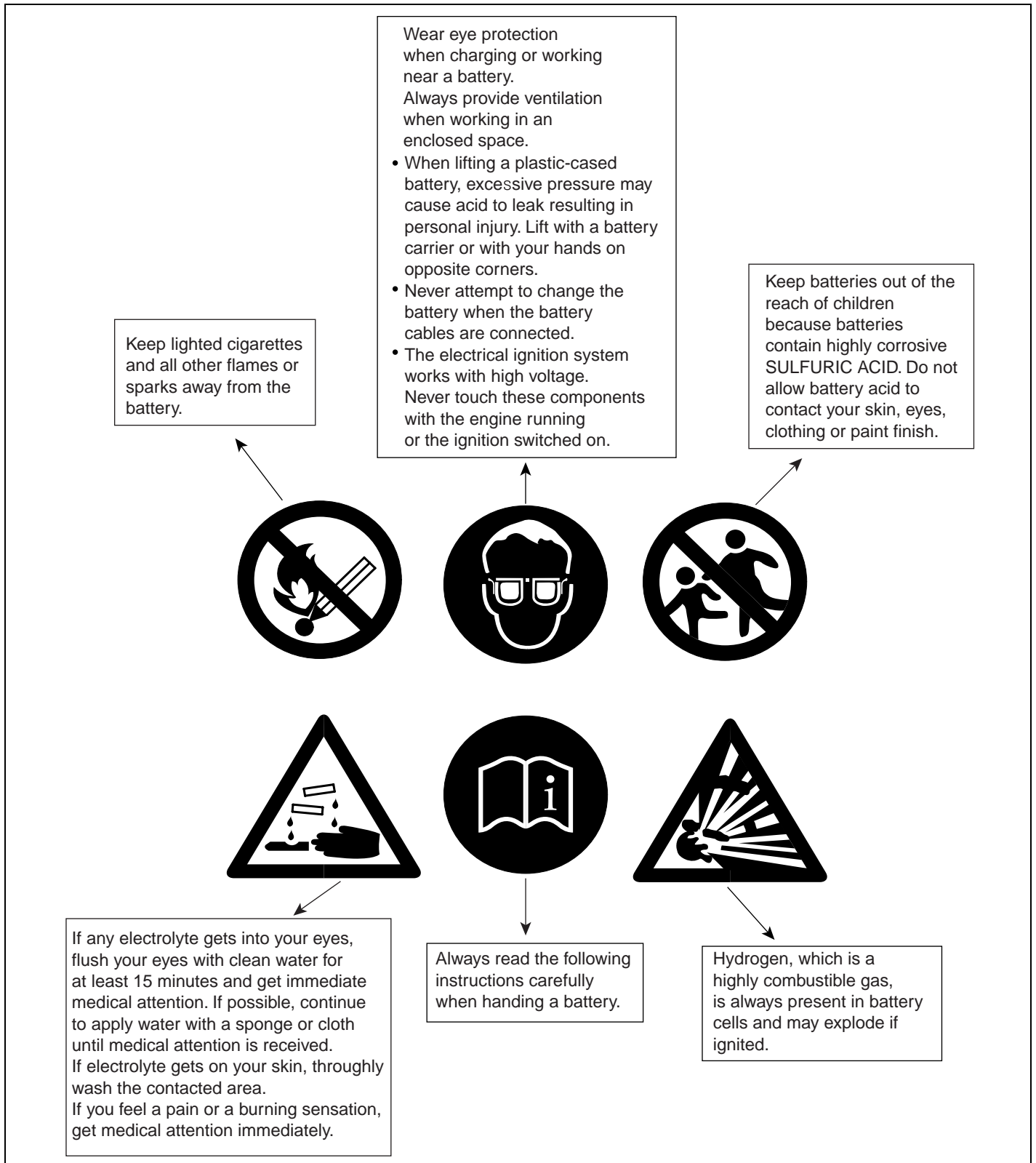

HANDLING AND STORING THE BATTERY

Battery Itself	<ul style="list-style-type: none">• Batteries should be stored in cool, dry (27 degrees Celsius) places and out of direct sunlight.• MF batteries are tightly sealed to prevent acid leakage. However, tilting the battery to an angle of 45 degrees can cause acid to leak through the vents on the sides. Therefore, batteries should always be stored in their upright positions. Prevent placing any aqueous or solid (i.e. conductors) bodies on top of the battery.• It is extremely dangerous to use tools, such as hammers, on the battery terminals when connecting cables to the mounted battery.
Battery on Vehicle	<ul style="list-style-type: none">• When storing the vehicle for long periods of time, make sure to remove the memory fuse at junction box to prevent natural discharging.• Also, run the engine for battery charging within 1 month if the memory fuse wasn't removed from the start of vehicle storing. If the memory fuse was removed, run the engine for battery charging within 3 months from the start of vehicle storing.

LIFT AND SUPPORT POINTS

⊗ WARNING

When heavy rear components such as suspension, fuel tank, spare tire, tailgate and trunk lid are to be removed, place additional weight in the luggage area before hoisting. When substantial weight is removed from the rear of the vehicle, the center of gravity may change and can cause the vehicle to tip forward on the hoist.

📄 NOTE

- Since each tire/wheel assembly weights approximately 30lbs (14kg), placing the front wheels in

the luggage area can assist with the weight distribution.

- *Use the same support points to support the vehicle on safety stands.*

1. Place the lift blocks under the support points as shown in the illustration.
2. Raise the hoist a few inches (centimeters) and rock the vehicle to be sure it is firmly supported.
3. Raise the hoist to full height to inspect the lift points for secure support.

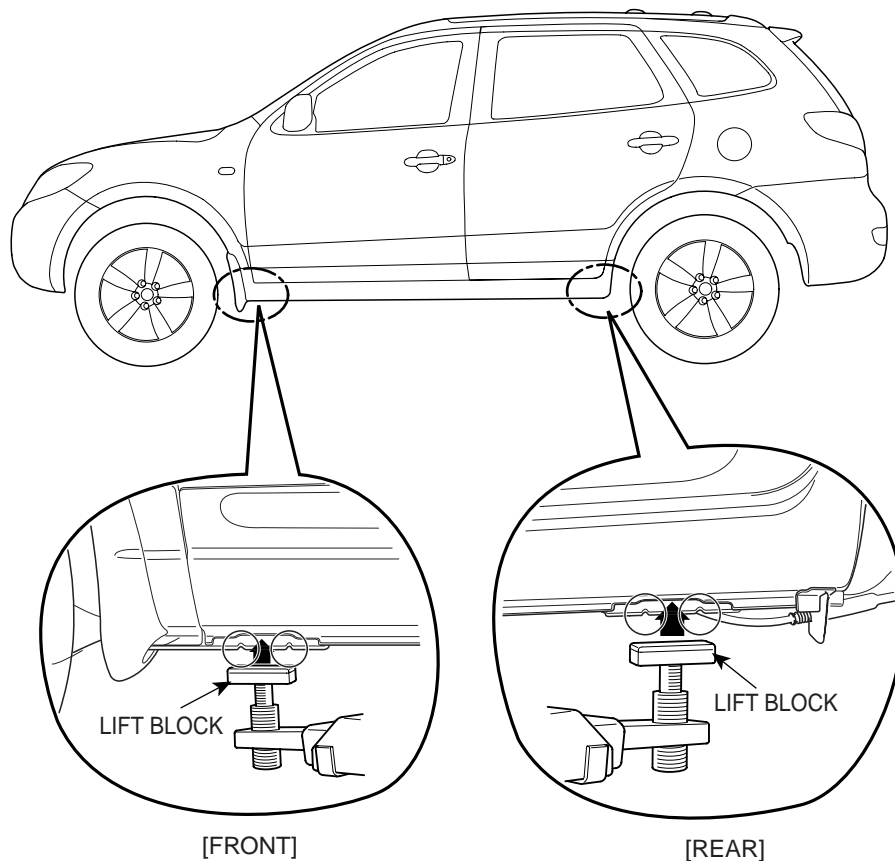

TOWING

If the vehicle needs to be towed, call a professional towing service. Never tow vehicle with just a rope or chain. It is very dangerous.

EMERGENCY TOWING

There are three popular methods of towing a vehicle :

Flat - bed Equipment- The operator loads the vehicle on the back of truck. This is best way of transporting the vehicle.

Wheel Lift Equipment- The tow truck uses two pivoting arms that go under the tires (front or rear) and lift them off the ground. The other two wheels remain on the ground.

Sling type Equipment- The tow truck metal cables with hooks on the ends. These hooks go around parts of the frame or suspension, and the cables lift that end of the vehicle off the ground. The vehicle's suspension and body can be seriously damaged if this method of towing is attempted.

If the vehicle cannot be transported by flat-bed, it should be towed with the front wheels off the ground. If due to damage, the vehicle must be towed with the front wheels on the ground, do not following :

Manual Transmission

- Release the parking brake.
- Shift the transmission to neutral

Automatic Transmission

- Release the parking brake.
- Start the engine.
- Shift to [D] position, then [N] position.
- Turn off the engine.

**CAUTION**

- ***Improper towing preparation will damage the transmission. Follow the above procedure exactly. If you cannot shift the transmission or start the engine(automatic transmission), your vehicle must be transported on a flatbed.***
- ***It is the best to tow vehicle no farther than 19miles (30km), and keep the speed below 30mph (50km/h).***
- ***Trying to lift or tow your vehicle by the bumpers will cause serious damage. The bumpers are not designed to support the vehicle's weight.***

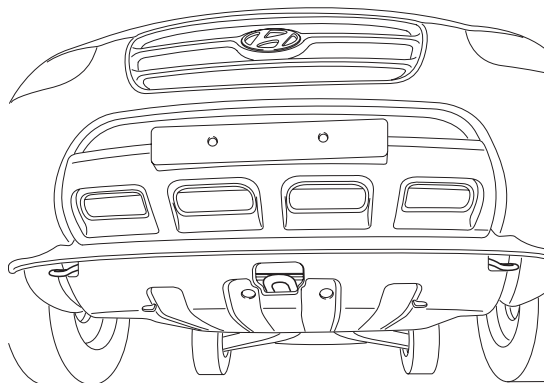
FRONT :

SCMG16008D

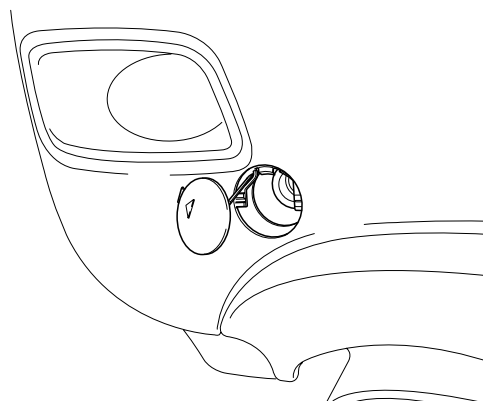
REAR :

SCMG16009D

TIGHTENING TORQUE TABLE OF STANDARD PARTS

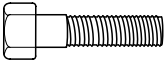
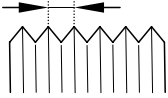
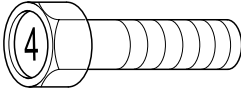
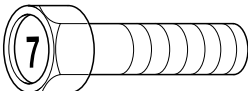
Bolt nominal diameter (mm)	Pitch (mm)	Torque Nm (kg.cm, lb.ft)	
		Head Mark 4	Head Mark 7
 <small>EAKE004E</small>	 <small>KASD100Y</small>	 <small>EAKE004F</small>	 <small>EAKE004G</small>
M5	0.8	3 ~ 4 (30 ~ 40, 2.2 ~ 2.9)	5 ~ 6 (50 ~ 60, 3.6 ~ 4.3)
M6	1.0	5 ~ 6 (50 ~ 50, 3.6 ~ 4.3)	9 ~ 11 (90 ~ 110, 6.5 ~ 8.0)
M8	1.25	12 ~ 15 (120 ~ 150, 9 ~ 11)	20 ~ 25 (200 ~ 250, 14.5 ~ 18.0)
M10	1.25	25 ~ 30 (250 ~ 300, 18 ~ 22)	30 ~ 50 (300 ~ 500, 22 ~ 36)
M12	1.25	35 ~ 45 (350 ~ 450, 25 ~ 33)	60 ~ 80 (600 ~ 800, 43 ~ 58)
M14	1.5	75 ~ 85 (750 ~ 850, 54 ~ 61)	120 ~ 140 (1,200 ~ 1,400, 85 ~ 100)
M16	1.5	110 ~ 130 (1,100 ~ 1,300, 80 ~ 94)	180 ~ 210 (1,800 ~ 2,100, 130 ~ 150)
M18	1.5	160 ~ 180 (1,600 ~ 1,800, 116 ~ 130)	260 ~ 300 (2,600 ~ 3,000, 190 ~ 215)
M20	1.5	220 ~ 250 (2,200 ~ 2,500, 160 ~ 180)	360 ~ 420 (3,600 ~ 4,200, 260 ~ 300)
M22	1.5	290 ~ 330 (2,900 ~ 3,300, 210 ~ 240)	480 ~ 550 (4,800 ~ 5,500, 350 ~ 400)
M24	1.5	360 ~ 420 (3,600 ~ 4,200, 260 ~ 300)	610 ~ 700 (6,100 ~ 7,000, 440 ~ 505)

NOTE

1. The torques shown in the table are standard values under the following conditions :
 - Nuts and bolts are made of galvanized steel bar.
 - Galvanized plain steel washers are inserted.
 - All nuts, bolts and plain washers are dry.
2. The torques shown in the table are not applicable :
 - When spring washers, toothed washers and the like are inserted.
 - If plastic parts are fastened.
 - If self-tapping screws or self-locking nuts are used.
 - If threads and surfaces are coated with oil.

3. If you reduce the torques in the table to the percentage indicated below, under the following conditions, it will be the standard value.
 - If spring washers are used : 85%
 - If threads and bearing surfaces are stained with oil : 85%

LUBRICANTS

RECOMMENDED LUBRICANTS

Parts		OIL & GREASE STANDARD
Engine Oil	Diesel 2.2	API CF -4 or ABOVE, ACEA B4 or ABOVE
	Gasoline 2.7	API SJ or ABOVE
Transaxle	Manual	SAE 75W/85 (API GL - 4)
	Auto	DIAMOND ATF SP-III, SK ATF SP-III
Power Steering		PSF -3
Breake Steering		DOT 3 or equivalent
Coolant		Ethylene glycol base for aluminium radiator
Transaxle linkage, parking breake cable mechanism, hood, door latch, seat adjuster, tailgate latch, door hinges, tailgate hinge		Multipurpose grease NIGL grade #2

⊗ WARNING

Always use Genuine Hyundai parts and recommended fluid.

Using any other type of parts and fluid can cause serious damaged if the vehicle. **RECOMMENDED LUBRICANTS**

LUBRICANTS CAPACITIES

Description		Gasoline(2.7)	Diesel(2.2)
Engine oil	Oil pan	4.2 (4.44, 3.70)	5.4 (5.70, 4.75)
	Oil filter	0.3 (0.32, 0.26)	0.5 (0.583, 0.44)
	Total	4.5 (4.75, 3.96)	5.9 (6.3, 5.2)
Cooling system		7.8 (8.2, 6.8)	7.9 (8.35, 6.95)
Manual transaxle		2.15 (2.3, 1.86)	2.15 (2.3, 1.86)
Automatic transaxle		7.8 (8.2, 6.8)	7.8 (8.2, 6.8)
Power steering		0.9 (0.95, 0.79)	0.9 (0.95, 0.79)

SELECTION OF ENGINE OIL

Recommended API classification : SJ OR SI ABOVE, CF
- 2.7 (Gasoline)

RECOMMENDED SAE VISCOSITY GRADES :

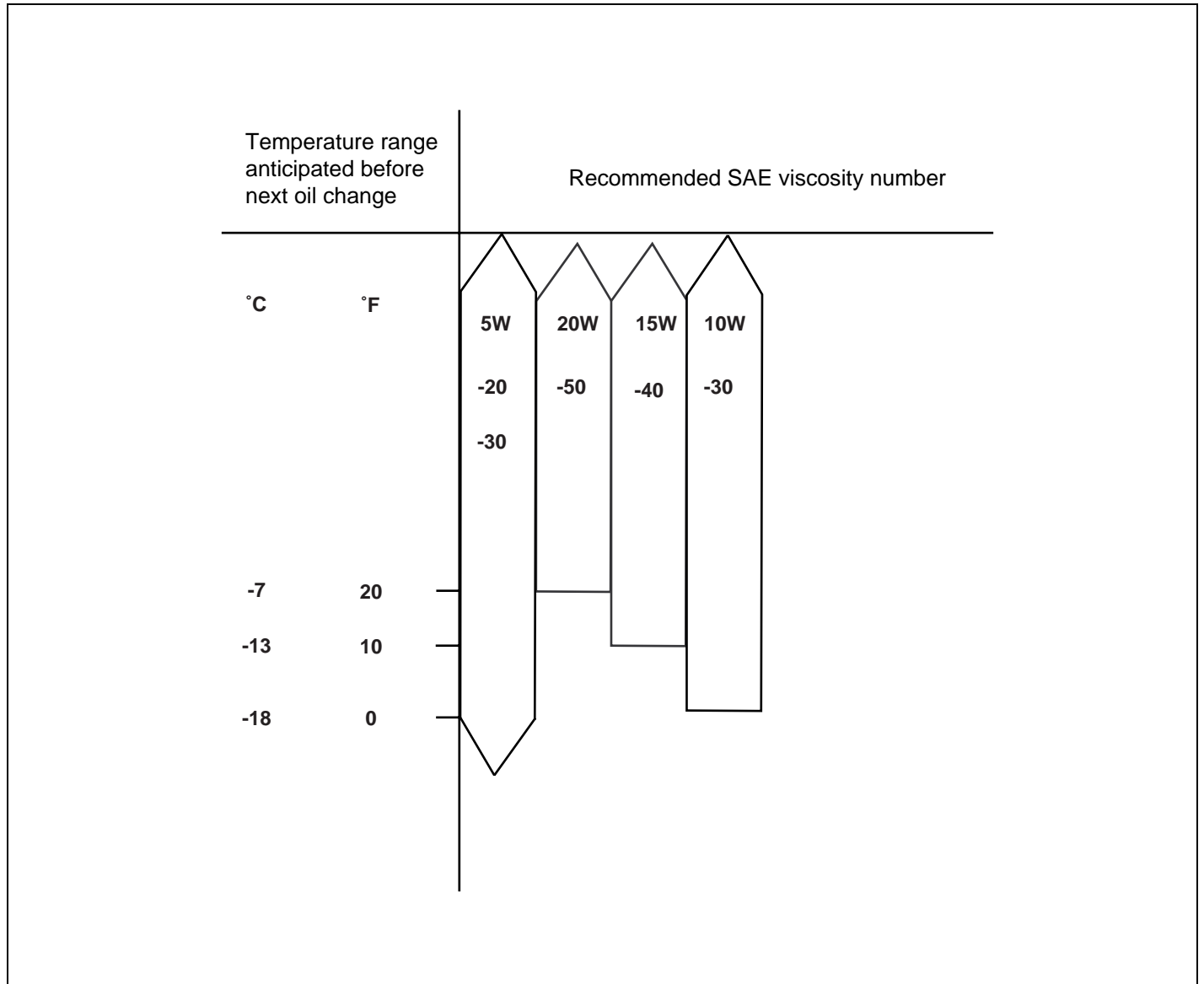

RECOMMENDED API CLASSIFICATION : CF-4 ABOVE - 2.2 (DIESEL)

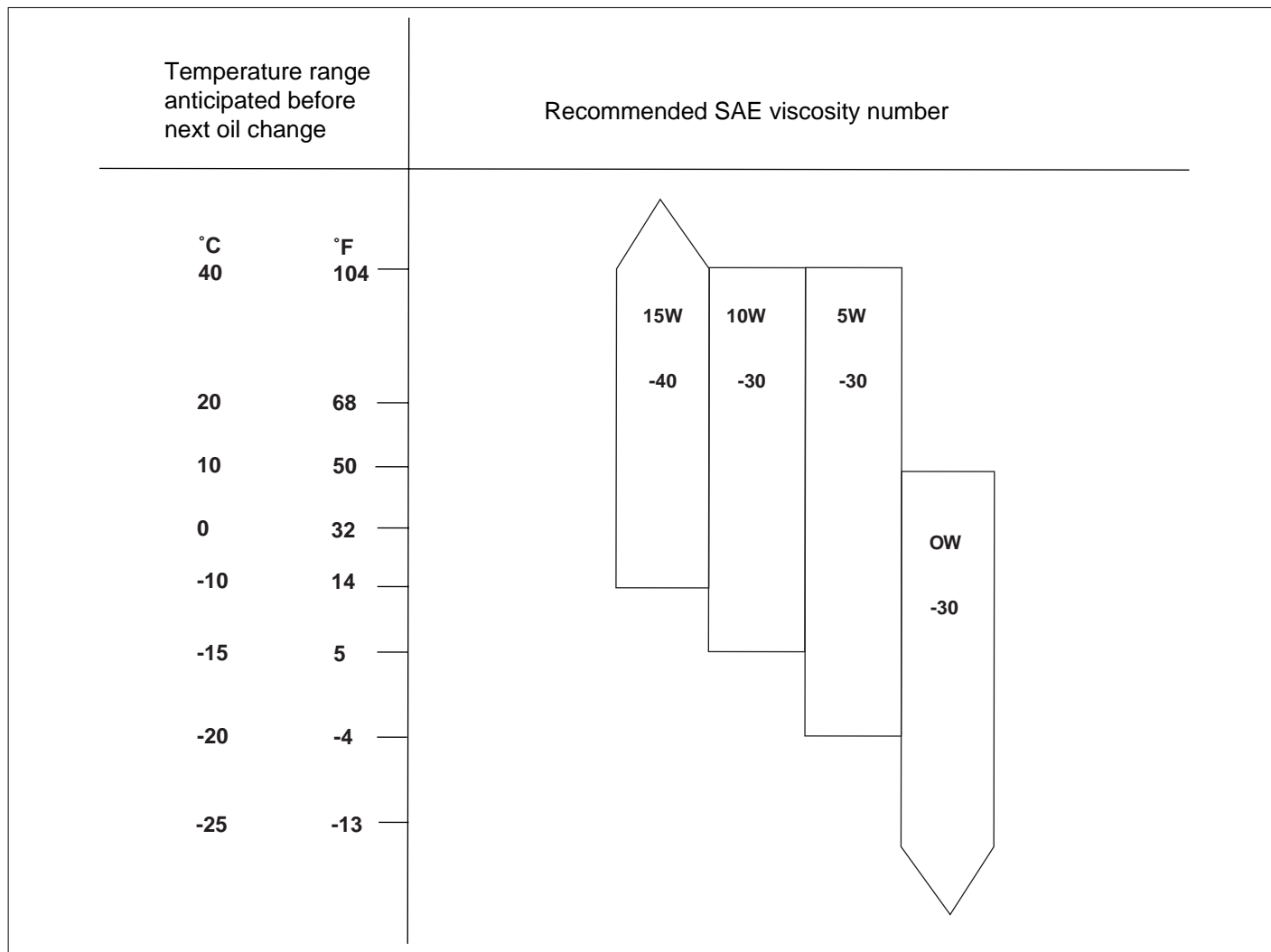

SCMGI6011L

NOTE

For best performance and maximum protection of all types of operation, select only those lubricants which :

1. Satisfy the requirements of the API classification.
2. Have the proper SAE grade number for expected ambient temperature range.

Lubricants which do not have both an SAE grade number and an API service classification on the container should not be used.

GENERAL SERVICE INFORMATION

PROTECTION OF THE VEHICLE

Always be sure to cover fenders, seats, and floor areas before starting work.

⚠ CAUTION

The support rod must be inserted into the hole near the edge of the hood whenever you inspect the engine compartment to prevent the hood from falling and causing possible injury.

Make sure that the support rod has been released prior to closing the hood. Always check to be sure the hood is firmly latched before driving the vehicle.

PREPARATION OF TOOLS AND MESURING EQUIPMENT

Be sure that all necessary tools and measuring equipment are available starting work.

SPECIAL TOOLS

Use special tools when they are required.

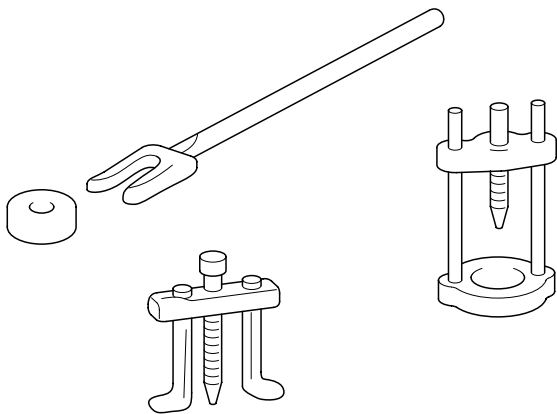

EAKE005A

REMOVAL OF PARTS

First find the cause of the problem and then determine whether removal or disassembly before starting the job.



EAKE005B

DISASSEMBLY

If the disassembly procedure is complex, requiring many parts to be disassembled, all parts should be disassembled in a way that will not aggect their performance or external appearance.

1. Inspection of parts

Each part, when removed, should be carefulley on spected for malfunction, deformation, damage, and other problems.

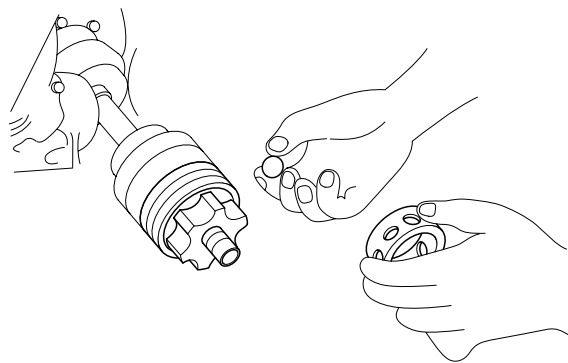

EAKE005C

2. Arrangement of parts

All disassembled parts should be carefully arranged for effective reassembly.
Be sure to separate and correctly identify the parts to be replaced from those that will be used again.

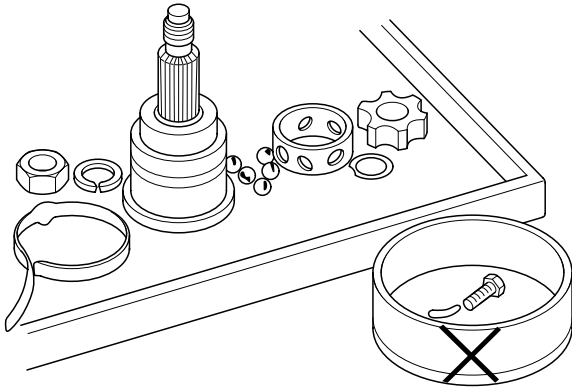

EAKE005D

3. Cleaning parts for reuse

All parts to be used again should be carefully and thoroughly cleaned by an appropriate method.

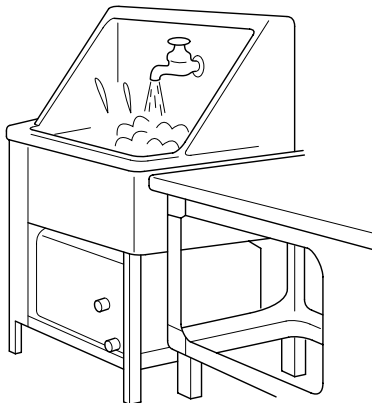

EAKE005E

PARTS

When replacing parts, use HYUNDAI genuine parts.

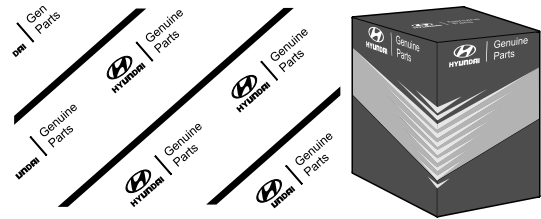

EAKE005F

REPLACEMENT

Standard values, such as torques and certain adjustments, must be strictly observed in the reassembly of all parts.

If removed, the following parts should always be replaced with new ones.

1. Oil seals
2. Gaskets
3. O-rings
4. Lock washers
5. Cotter pins (split pins)
6. Plastic nuts

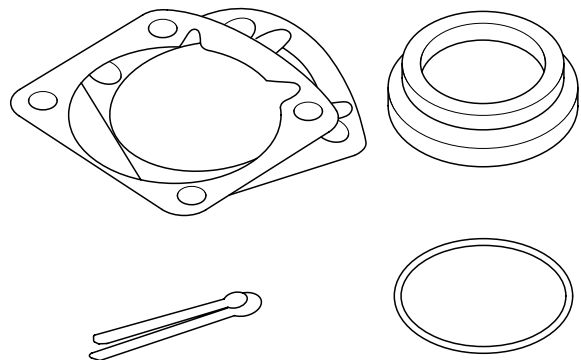

EAKE005G

Depending on their location.

7. Sealant should be applied to gaskets.
8. Oil should be applied to the moving components of parts.
9. Specified oil or grease should be applied to the prescribed locations (oil seals, etc) before assembly.

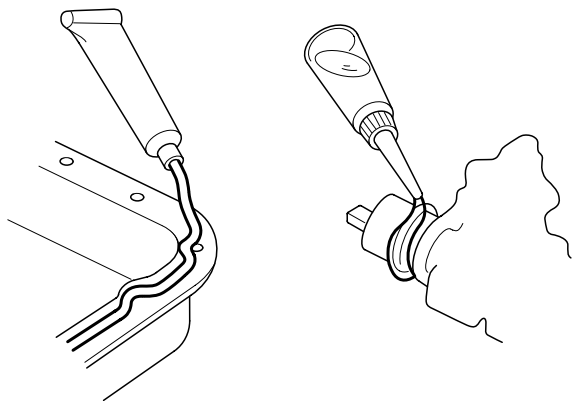

EAKE005H

ADJUSTMENT

Use gauges and testers to adjust correctly the parts to standard values correctly.

ELECTRICAL SYSTEM

1. Be sure to disconnect the battery cable from the negative (-) terminal of the battery.
2. Never pull on the wires when disconnecting connectors.
3. Locking connectors will click when the connector is secure.
4. Handle sensors and relays carefully. Be careful not to drop them against other parts.

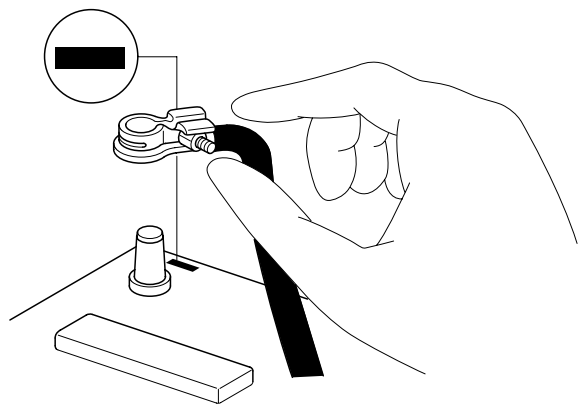

EAKE005I

RUBER PARTS AND TUBES

Always prevent gasoline or from touching rubber parts or tubing.

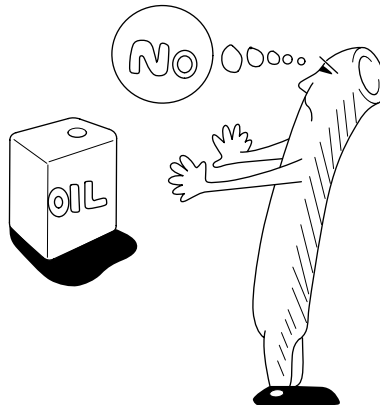

EAKE005J

MEASURING BODY DIMENSIONGS

1. Basically, all measurements in this manual are taken with a tracking gauge.
2. When a measuring tape is used, check to be sure there is no elongation, twisting or bending.
3. For measuring dimensions, both projected dimensioners and actual - measurement dimensions are used in this manual.

DIMENSIONS PROJECTED

1. These are the dimensions measured when the measurement points are projected from the vehicle's surface, and are the reference dimensions used for used for body alterations.
2. If the length of the tracking gauge probes is adjustable, measure it by lengthening one of two probes as long as the different value in height of the two surface.

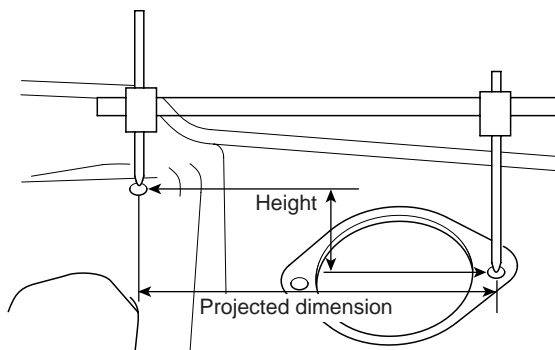

EAKE005K

MEASURING ACTUAL DIMENSIONS

1. These dimensions indicate the actual linear distance between measurement points, and are used as the reference dimensions when a tracking gauge is used for measurement.
2. First adjust both probes to the same length ($A=A'$) before measurement.

NOTE

Check the probes and gauge itself to make sure there is no free play.

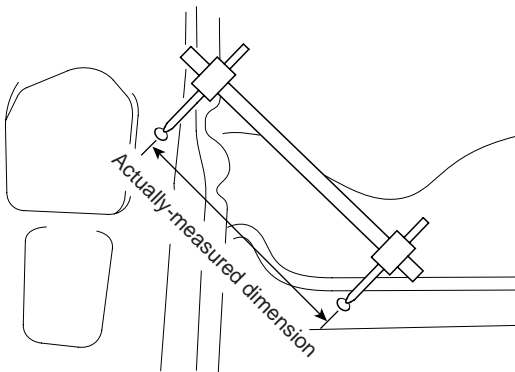

EAKE005L

MEASUREMENT POINT

Measurements should be taken at the center of the hole.

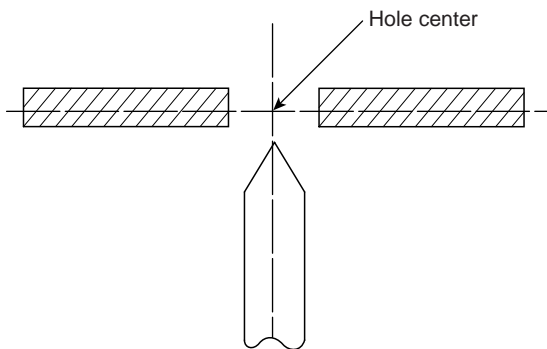

EAKE005M

CHECKING CABLES AND WIRES

1. Check the terminal for tightness.
2. Check terminals and wires for corrosion from battery electrolyte, etc.
3. Check terminals and wires for open circuits.
4. Check wire insulation and coating for damage, cracks and degrading.
5. Check the conductive parts of terminals for contact with other metallic parts (vehicle body and other parts).
6. Check grounded parts to verify that there is complete continuity between their attaching bolt(s) and the vehicle's body.
7. Check for incorrect wiring.
8. Check that the wiring is so clamped to prevent contact with sharp corners of the vehicle body, etc. or hot parts (exhaust manifold, etc.)
9. Check that the wiring is clamped firmly to provide enough clearance from the fan pulley, fan belt and other rotating or moving parts.
10. Check that the wiring has a little space so that it can vibrate between fixed and moving parts such as the vehicle body and the engine.

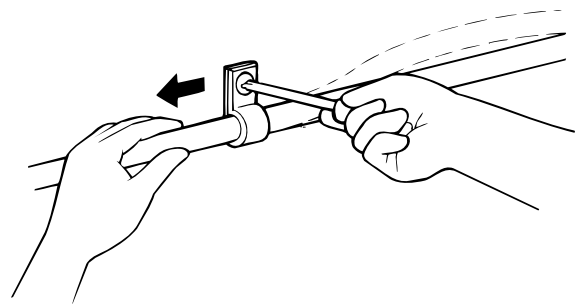

EAKE005N

CHECK FUSES

A blade type fuse test taps provided to allow checking the fuse itself without removing it from the fuse box. The fuse is good if the test lamp lights up when one lead is connected to the test taps (one at a time) and the other lead is grounded. (Turn the ignition switch so that the fuse circuit becomes operative)

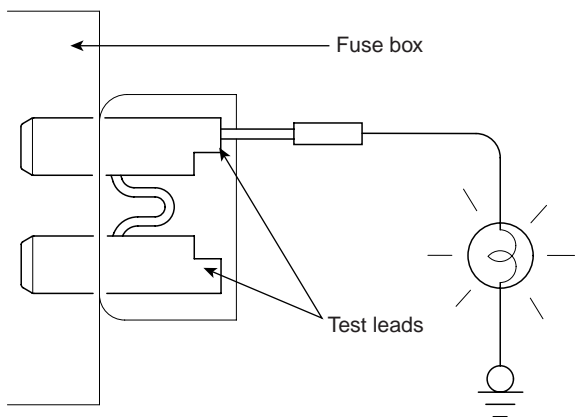

EAKE005O

2. Attach the wiring harnesses with clamps so that there is no slack. However, for any harness which passes the engine or other vibrating parts of the vehicle, allow some slack within a range that does not allow the engine vibrations to cause the harness to come into contact with any of the surrounding parts and then secure the harness by using a clamp.

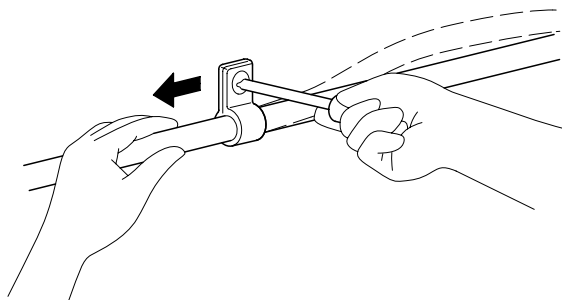

EAKE005R

SERVICING THE ELECTRICAL SYSTEM

1. Prior to servicing the electrical system, be sure to turn off the ignition switch and disconnect the battery ground cable.

NOTE

In the course of MFI or ELC system diagnosis, when the battery cable is removed, any diagnostic trouble code retained by the computer will be cleared. Therefore, if necessary, read the diagnostic before removing the battery cable.

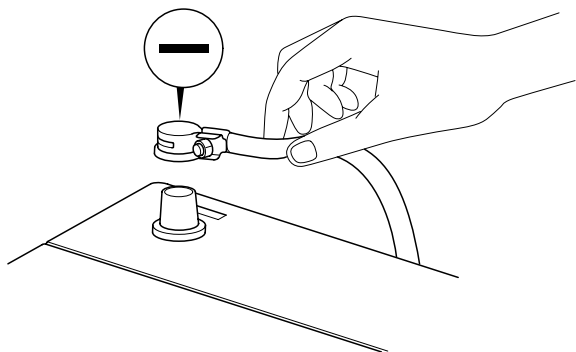

EAKE005P

3. If any section of a wiring harness interferes with the edge of a parts, or a corner, wrap the section of the harness with tape or something similar in order to protect it from damage.

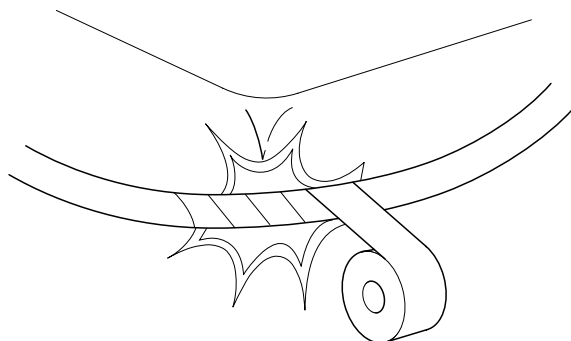

EAKE005S

4. When installing any parts, be careful not to pinch or damage any of the wiring harness.

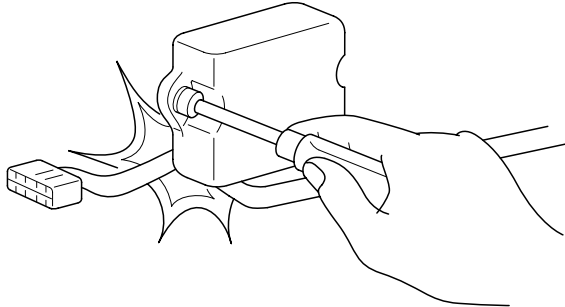

EAKE005T

7. Loose connectors cause problems. Make sure that the connectors are always securely fastened.

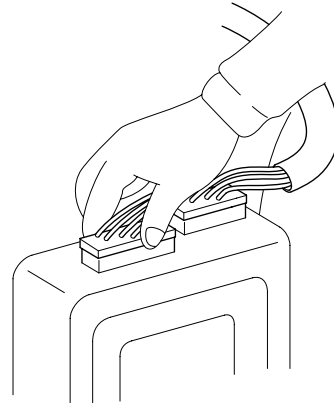

EAKE006B

5. Never throw relays, sensors or electrical parts, or expose them to strong shock.

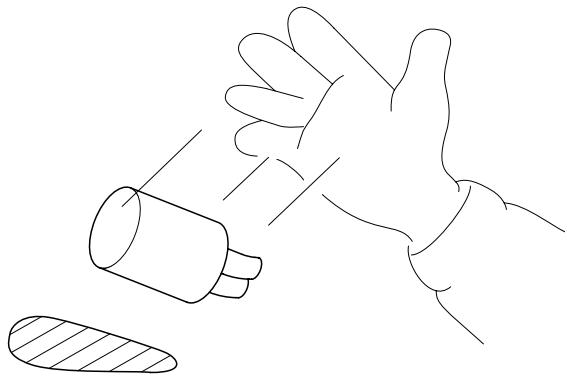

EAKE005U

8. When disconnecting a connector, be sure to grip only the connector, not the wires.

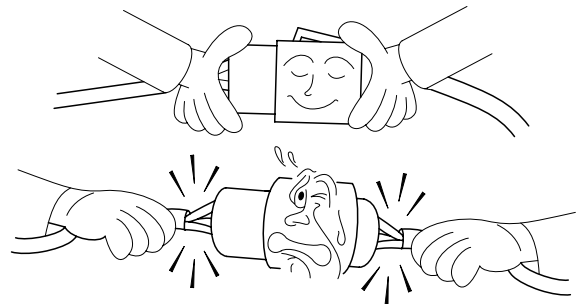

EAKE006C

6. The electronic parts used in the computer, relays, etc. are readily damaged by heat. If there is a need for service operations that may cause the temperature to exceed 80°C (176°F), remove the electronic parts before hand.

9. Disconnect connector which have catches by pressing in the direction of the arrows shown the illustration.

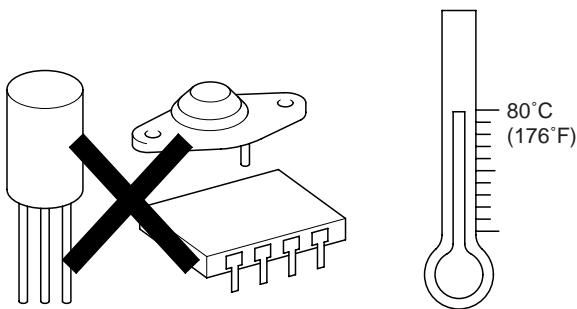

EAKE006A

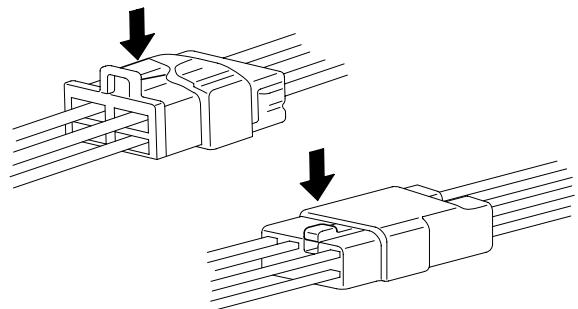

EAKE006D

10. Connect connectors which have catches by inserting the connectors until they make a clicking sound.

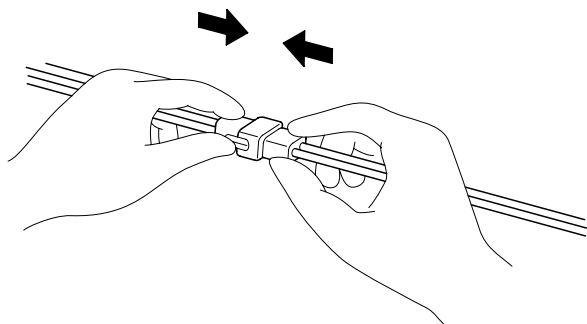

EAKE006E

11. When using a circuit tester to check continuity or voltage on connector terminals, insert the test probe into the harness side. If the connector is a sealed connector, insert the test probe through the hole in the rubber cap until contacts the terminal, being careful not to damage the insulation of the wires.

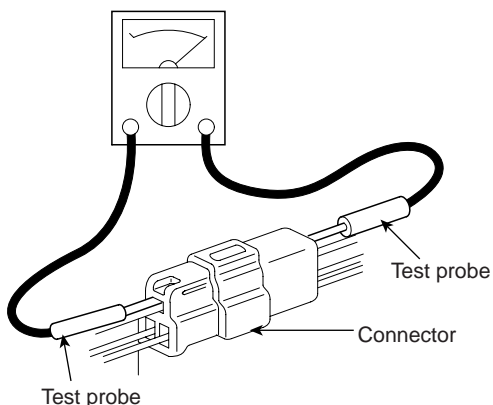

EAKE006G

12. To avoid overloading the wiring, take the electrical current load of the optional equipment into consideration, and determine the appropriate wire size.

Nominal size	SAE gauge No.	Permissible current	
		In engine compartment	Other areas
0.3mm ²	AWG 22	-	5A
0.5mm ²	AWG 20	7A	13A
0.85mm ²	AWG 18	9A	17A
1.25mm ²	AWG 16	12A	22A
2.0mm ²	AWG 14	16A	30A
3.0mm ²	AWG 12	21A	40A
5.0mm ²	AWG 10	31A	54A

PRECAUTIONS FOR CATALYTIC CONVERTER

⚠ CAUTION

If a large amount of unburned gasoline flow into the converter, it may overheat and create a fire hazard. To prevent this observe the following precautions and explain them to your customer.

1. Use only unleaded gasoline.
2. Do not run the engine while the car is at rest for a long time. Avoid running the engine at fast idle for more than 10minutes and idle speed for more than 20 minutes.
3. Avoid start-jump tests. Do start-jumps only when absolutely necessary. Perform this test as rapidly as possible and, while testing, never race the engine.
4. Do not measure engine compression for an extended time. Engine compression tests must be made as rapidly as possible.
5. Avoid coasting with the ignition turned and during prolonged braking.
6. Do not dispose of used catalytic converter together with parts contaminated with gasoline or oil.