

Fuel System

(J3 TCI - DSL2.9)

GENERAL INFORMATION

SPECIFICATION	FLB -2
SEALANT	FLB -3
SERVICE STANDARD	FLB -3
TIGHTENING TORQUES	FLB -3
BASIC TROUBLESHOOTING	FLB -4
SYSPTOM TROUBLESHOOTING GUIDE CHART	FLB -12

DIESEL CONTROL SYSTEM

COMPONENTS	FLB- 23
ECM CONNECTOR	FLB- 26

DTC TROUBLESHOOTING PROCEDURES

INSPECTION CHART FOR DIAGNOSTIC TROUBLE CODES (DTC)	FLB-30
TROUBLESHOOTING FOR DTC	
P0100	FLB-36
P0101 P0102	FLB-37
P0115	FLB-41
P0120 P0220	FLB-45
P0180	FLB-50
P0190	FLB-54
P0201 P0202 P0203 P0204	FLB-58
P0226	FLB-62
P0325	FLB-63
P0335	FLB-67
P0340	FLB-71
P0380 P0382	FLB-76
P0381	FLB-80
P0400	FLB-83
P0560	FLB-86
P0650	FLB-90
P1119 P1120	FLB-93
P1140	FLB-99
P1150	FLB-103
P1300	FLB-104
P1310	FLB-105
P1500	FLB-109
P1543	FLB-113
P1608	FLB-116
P1610	FLB-117
P1614	FLB-124
P1620	FLB-126
P1640	FLB-129

P1674	FLB-132
P1786	FLB-135
P2264	FLB-138
P2269	FLB-141

FUEL DELIVERY SYSTEM-DIESEL

COMMON RAIL FUEL	
INJECTION SYSTEM.....	FLB-144
LOW PRESSURE LINE	FLB-146
HIGH PRESSURE LINE	FLB-147
COMPONENTS	FLB-148
INJECTOR	
REMOVAL	FLB-149
INSTALLATION	FLB-150
ACCUMULATOR (COMMON RAIL)	
REMOVAL	FLB-152
INSTALLATION	FLB-153
FUEL LINE	
REMOVAL	FLB-154
INSTALLATION	FLB-155



GENERAL

SPECIFICATION EB2FEC9C

Items		Specification		
Fuel Tank		Capacity	75l	
Fuel Pump		Type	High pressure pump (Gear driven type)	
Fuel Filter		Type	High pressure type	
Fuel Pressure (at common rail)		Pressure	1,600 bar (1,631.5kgf/cm ²)	
SEN- SORS	Mass Air Flow Sensor (MAFS)	Type	HOT FILM type	
	Intake Air Temperature Sensor (IATS)	Type	Thermister type	
		Specification	-40°C (-40°F)	39.3kΩ
			-20°C(-4°F)	13.9kΩ
			0°C(32°F)	5.5kΩ
			20°C(68°F)	2.4kΩ
			40°C(104°F)	1.2kΩ
			60°C(140°F)	0.6kΩ
	80°C(176°F)		0.3kΩ	
	Accelerator Position Sensor (APS)	Type	Thermister type	
	Camshaft Position Sensor (CMPS)	Type	Hall sensor type	
	Crankshaft Position Sensor (CKPS)	Type	Magnetic type	
	Rail Pressure Sensor (RPS)	Type	Piezo electricity type	
	Fuel Temperature Sensor (FTS)	Type	Thermister type	
		Specification	-30°C(-22°F)	22.2 ~ 31.8kΩ
			-20°C(-4°F)	13.2 ~ 18.1kΩ
			0°C(32°F)	5.2 ~ 6.6kΩ
			20°C(68°F)	2.3 ~ 2.7kΩ
			40°C(104°F)	1.1 ~ 1.3kΩ
			60°C(140°F)	0.54 ~ 0.65kΩ
80°C(176°F)	0.30 ~ 0.32kΩ			
Engine Coolant Temperature Sensor (ECTS)	Type	Thermister type		
	Specification	-40°C (-40°F)	44.4kΩ	
		-20°C(-4°F)	13.4 ~ 16.8kΩ	
		0°C(32°F)	5.74kΩ	
		20°C(68°F)	2.3 ~ 2.6kΩ	
		40°C(104°F)	1.15kΩ	
		60°C(140°F)	0.58kΩ	
80°C(176°F)		0.32kΩ		

Items		Specification	
ACTUATORS	Injector	Type	Solenoid type
		Number	4
	Inlet Metering Valve (IMV)	Resistance	5.5Ω at 20°C(68°F)
	EGR Solenoid Valve	Resistance	15.0 ~ 16.0Ω at 20°C(68°F)

SEALANT EE554B8A

Engine Coolant Temperature Sensor (ECTS)	LOCTITE 962T
--	--------------

SERVICE STANDARD

Idle Speed	800±100 rpm
------------	-------------

TIGHTENING TORQUES

Items		Kgf-m	N-m	lbf-ft
ENGINE CONTROL SYSTEM	Engine Coolant Temperature Sensor (ECTS)	2.00	19.61	14.47
	Knock Sensor (KS)	1.50 ~ 2.50	14.71 ~ 24.52	10.85 ~ 18.08
	Crankshaft Position Sensor (CKPS)	0.90 ~ 1.00	8.83 ~ 9.81	6.51 ~ 7.23
	EGR Solenoid Valve	0.80 ~ 1.10	7.85 ~ 10.79	5.79 ~ 7.96
FUEL DELIVERY SYSTEM	High pressure pump mounting bolts (on timing case)	2.20 ~ 2.60	21.57 ~ 25.50	15.91 ~ 18.81
	High pressure pump mounting bolts (on bracket)	2.20 ~ 2.60	21.57 ~ 25.50	15.91 ~ 18.81
	High Pressure Pipe connecting between high pressure pump and common rail	3.65 ~ 4.35	35.79 ~ 42.66	26.40 ~ 31.46
	High Pressure Pipe connecting between common rail and injectors	3.65 ~ 4.35	35.79 ~ 42.66	26.40 ~ 31.46
	Common rail mounting bolts	1.90 ~ 2.30	18.63 ~ 22.56	13.74 ~ 16.64
	Injector clamp bolt	2.00 ~ 2.20	19.61 ~ 21.57	14.47 ~ 15.91

BASIC TROUBLESHOOTING E40A46A4

BASIC TROUBLESHOOTING GUIDE

1	Bring Vehicle to Workshop
2	Analyze Customer's Problem <ul style="list-style-type: none"> • Ask the customer about the conditions and environment relative to the issue (Use CUSTOMER PROBLEM ANALYSIS SHEET).
3	Verify Symptom, and then Check DTC and Freeze Frame Data <ul style="list-style-type: none"> • Connect Hi-Scan (Pro) to Diagnostic Link Connector (DLC). • Record the DTC and freeze frame data. <p> NOTE To erase DTC and freeze frame data, Refer to Step 5.</p>
4	Confirm the Inspection Procedure for the System or Part <ul style="list-style-type: none"> • Using the SYMPTOM TROUBLESHOOTING GUIDE CHART, choose the correct inspection procedure for the system or part to be checked.
5	Erase the DTC and Freeze Frame data (WARNING) NEVER erase DTC and freeze frame data before completing Step 2 MIL/DTC in "CUSTOMER PROBLEM ANALYSIS SHEET".
6	Inspect Vehicle Visually <ul style="list-style-type: none"> • Go to Step 11, if you recognize the problem.
7	Recreate (Simulate) Symptoms the DTC <ul style="list-style-type: none"> • Try to recreate or simulate the symptoms and conditions of the malfunction as described by customer. • If DTC(s) is/are displayed, simulate the condition according to troubleshooting procedure for the DTC.
8	Confirm Symptoms of Problem <ul style="list-style-type: none"> • If DTC(s) is/are not displayed, go to Step 9. • If DTC(s) is/are displayed, go to Step 11.
9	Recreate (Simulate) Symptom <ul style="list-style-type: none"> • Try to recreate or simulate the condition of the malfunction as described by the customer.
10	Check the DTC <ul style="list-style-type: none"> • If DTC(s) does(do) not occur, refer to BASIC INSPECTION in INTERMITTENT PROBLEM PROCEDURE. • If DTC(s) occur(s), go to Step 11.
11	Perform troubleshooting procedure for DTC
12	Adjust or repair the vehicle

13	Confirmation test
----	-------------------

14	END
----	-----

CUSTOMER PROBLEM ANALYSIS SHEET

1. VEHICLE INFORMATION

(I) VIN:
(II) Production Date:
(III) Odometer Reading: (miles/km)

2. SYMPTOMS

<input type="checkbox"/> Unable to start	<input type="checkbox"/> Engine does not turn over <input type="checkbox"/> Incomplete combustion <input type="checkbox"/> Initial combustion does not occur
<input type="checkbox"/> Difficult to start	<input type="checkbox"/> Engine turns over slowly <input type="checkbox"/> Other _____
<input type="checkbox"/> Poor idling	<input type="checkbox"/> Rough idling <input type="checkbox"/> Incorrect idling <input type="checkbox"/> Unstable idling (High: _____ rpm, Low: _____ rpm) <input type="checkbox"/> Other _____
<input type="checkbox"/> Engine stall	<input type="checkbox"/> Soon after starting <input type="checkbox"/> After accelerator pedal depressed <input type="checkbox"/> After accelerator pedal released <input type="checkbox"/> During A/C ON <input type="checkbox"/> Shifting from N to D-range <input type="checkbox"/> Other _____
<input type="checkbox"/> Others	<input type="checkbox"/> Poor driving (Surge) <input type="checkbox"/> Knocking <input type="checkbox"/> Poor fuel economy <input type="checkbox"/> Back fire <input type="checkbox"/> After fire <input type="checkbox"/> Other _____

3. ENVIRONMENT

Problem frequency	<input type="checkbox"/> Constant <input type="checkbox"/> Sometimes (_____) <input type="checkbox"/> Once only <input type="checkbox"/> Other _____
Weather	<input type="checkbox"/> Fine <input type="checkbox"/> Cloudy <input type="checkbox"/> Rainy <input type="checkbox"/> Snowy <input type="checkbox"/> Other _____
Outdoor temperature	Approx. _____ °C/°F
Place	<input type="checkbox"/> Highway <input type="checkbox"/> Suburbs <input type="checkbox"/> Inner City <input type="checkbox"/> Uphill <input type="checkbox"/> Downhill <input type="checkbox"/> Rough road <input type="checkbox"/> Other _____
Engine temperature	<input type="checkbox"/> Cold <input type="checkbox"/> Warming up <input type="checkbox"/> After warming up <input type="checkbox"/> Any temperature
Engine operation	<input type="checkbox"/> Starting <input type="checkbox"/> Just after starting (____ min) <input type="checkbox"/> Idling <input type="checkbox"/> Racing <input type="checkbox"/> Driving <input type="checkbox"/> Constant speed <input type="checkbox"/> Acceleration <input type="checkbox"/> Deceleration <input type="checkbox"/> A/C switch ON/OFF <input type="checkbox"/> Other _____

4. MIL/DTC

MIL (Malfunction Indicator Lamp)	<input type="checkbox"/> Remains ON <input type="checkbox"/> Sometimes lights up <input type="checkbox"/> Does not light
DTC	<input type="checkbox"/> Normal <input type="checkbox"/> DTC (_____) <input type="checkbox"/> Freeze Frame data

BASIC INSPECTION PROCEDURE

MEASURING CONDITION OF ELECTRONIC PARTS' RESISTANCE

The measured resistance at high temperature after vehicle running may be high or low. So all resistance must be measured at ambient temperature (20°C, 68°F), unless there is any notice.

 **NOTE**

The measured resistance in except for ambient temperature (20°C, 68°F) is reference value.

INTERMITTENT PROBLEM INSPECTION PROCEDURE

Sometimes the most difficult case in troubleshooting is when a problem symptom occurs but does not occur again during testing. An example would be if a problem appears only when the vehicle is cold but has not appeared when warm. In this case, technician should thoroughly make out a "CUSTOMER PROBLEM ANALYSIS SHEET" and recreate (simulate) the environment and condition which occurred when the vehicle was having the issue.

1. Clear Diagnostic Trouble Code (DTC).
2. Inspect connector connection, and check terminal for poor connections, loose wires, bent, broken or corroded pins, and then verify that the connectors are always securely fastened.

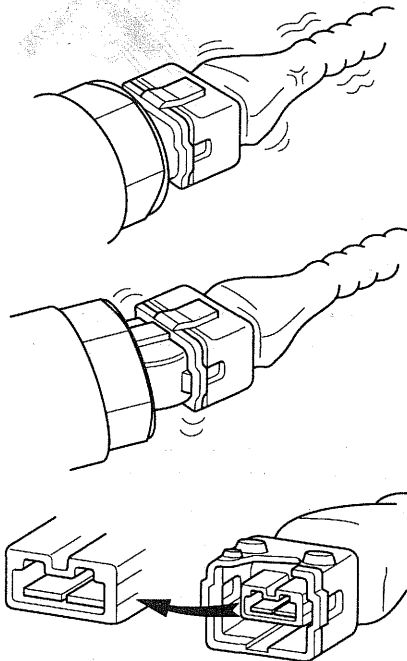

BFG321A

3. Slightly shake the connector and wiring harness vertically and horizontally.
4. Repair or replace the component that has a problem.
5. Verify that the problem has disappeared with the road test.

● SIMULATING VIBRATION

- a. Sensors and Actuators : Slightly vibrate sensors, actuators or relays with finger.

⊗ **WARNING**

Strong vibration may break sensors, actuators or relays

- b. Connectors and Harness : Lightly shake the connector and wiring harness vertically and then horizontally.

● SIMULATING HEAT

- a. Heat components suspected of causing the malfunction with a hair dryer or other heat source.

⊗ **WARNING**

- **DO NOT heat components to the point where they may be damaged.**
- **DO NOT heat the ECM directly.**

● SIMULATING WATER SPRINKLING

- a. Sprinkle water onto vehicle to simulate a rainy day or a high humidity condition.

⊗ **WARNING**

DO NOT sprinkle water directly into the engine compartment or electronic components.

● SIMULATING ELECTRICAL LOAD

- a. Turn on all electrical systems to simulate excessive electrical loads (Radios, fans, lights, etc.).

CONNECTOR INSPECTION PROCEDURE

1. Handling of Connector

- a. Never pull on the wiring harness when disconnecting connectors.

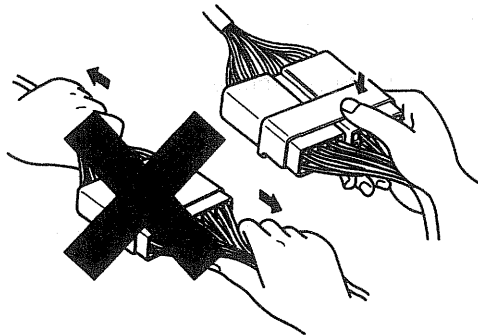

BFG015F

- b. When removing the connector with a lock, press or pull locking lever.

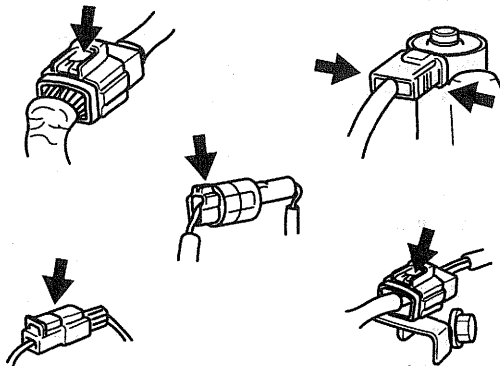

BFG015G

- c. Listen for a click when locking connectors. This sound indicates that they are securely locked.

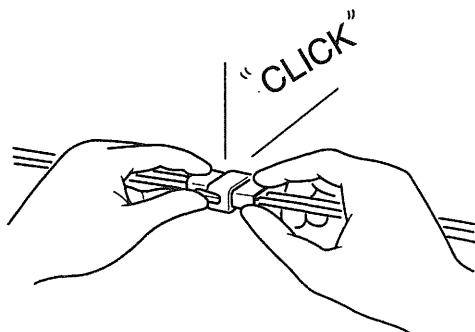

BFG015H

- d. When a tester is used to check for continuity, or to measure voltage, always insert tester probe from wire harness side.

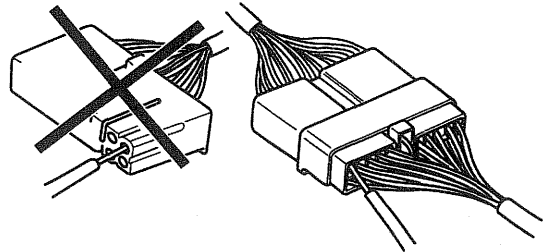

BFG015I

- e. Check waterproof connector terminals from the connector side. Waterproof connectors cannot be accessed from harness side.

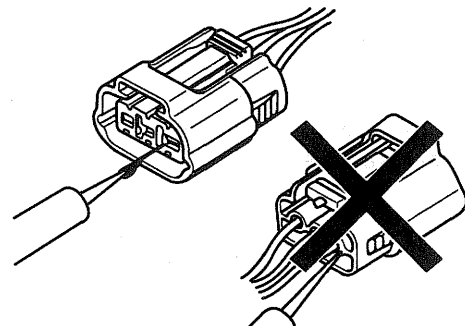

BFG015J

NOTE

- Use a fine wire to prevent damage to the terminal.
- Do not damage the terminal when inserting the tester lead.

2. Checking Point for Connector

- a. While the connector is connected: Hold the connector, check connecting condition and locking efficiency.
- b. When the connector is disconnected: Check missed terminal, crimped terminal or broken core wire by slightly pulling the wire harness. Visually check for rust, contamination, deformation and bend.
- c. Check terminal tightening condition: Insert a spare male terminal into a female terminal, and then check terminal tightening conditions.

- d. Pull lightly on individual wires to ensure that each wire is secured in the terminal.

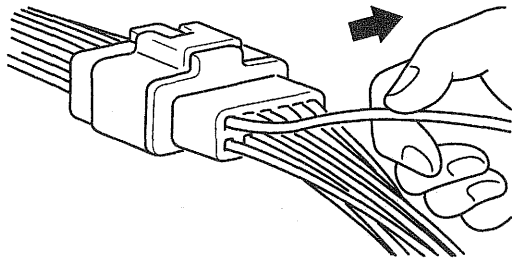

BFGE015K

If an open circuit occurs (as seen in [FIG. 1]), it can be found by performing Step 2 (Continuity Check Method) or Step 3 (Voltage Check Method) as shown below.

FIG. 1

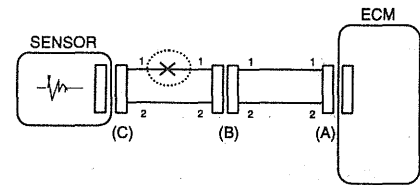

BFGE501A

- 3. Repair Method of Connector Terminal
 - a. Clean the contact points using air gun and/or shop rag.

NOTE

Never use sand paper when polishing the contact points, otherwise the contact point may be damaged.

- b. In case of abnormal contact pressure, replace the female terminal.

- 2. Continuity Check Method

NOTE

When measuring for resistance, lightly shake the wire harness above and below or from side to side.

Specification (Resistance)

1Ω or less → Normal Circuit

1MΩ or Higher → Open Circuit

WIRE HARNESS INSPECTION PROCEDURE

1. Before removing the wire harness, check the wire harness position and crimping in order to restore it correctly.
2. Check whether the wire harness is twisted, pulled or loosened.
3. Check whether the temperature of the wire harness is abnormally high.
4. Check whether the wire harness is rotating, moving or vibrating against the sharp edge of a part.
5. Check the connection between the wire harness and any installed part.
6. If the covering of wire harness is damaged; secure, repair or replace the harness.

ELECTRICAL CIRCUIT INSPECTION PROCEDURE

● CHECK OPEN CIRCUIT

1. Procedures for Open Circuit
 - Continuity Check
 - Voltage Check

FIG. 2

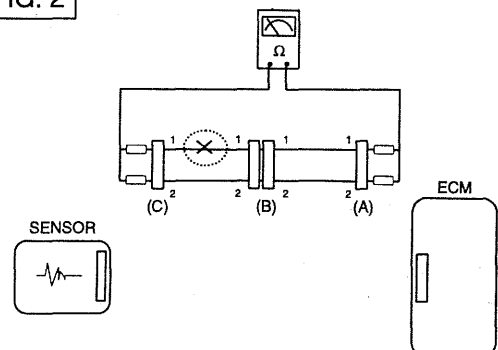

BFGE501B

- a. Disconnect connectors (A), (C) and measure resistance between connector (A) and (C) as shown in [FIG. 2].

In [FIG.2.] the measured resistance of line 1 and 2 is higher than 1MΩ and below 1Ω respectively. Specifically the open circuit is line 1 (Line 2 is normal). To find exact break point, check sub line of line 1 as described in next step.

- b. Disconnect connector (B), and measure for resistance between connector (C) and (B1) and between (B2) and (A) as shown in [FIG. 3].

In this case the measured resistance between connector (C) and (B1) is higher than $1M\Omega$ and the open circuit is between terminal 1 of connector (C) and terminal 1 of connector (B1).

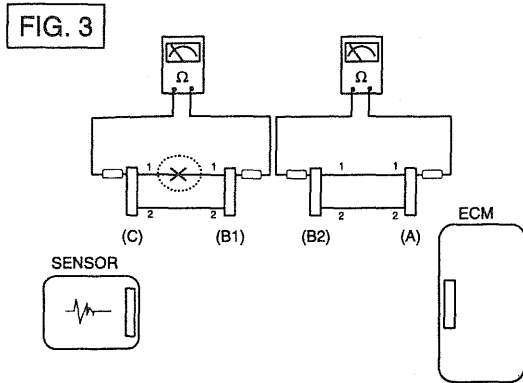

BFG501C

3. Voltage Check Method

- a. With each connector still connected, measure the voltage between the chassis ground and terminal 1 of each connectors (A), (B) and (C) as shown in [FIG. 4].

The measured voltage of each connector is 5V, 5V and 0V respectively. So the open circuit is between connector (C) and (B).

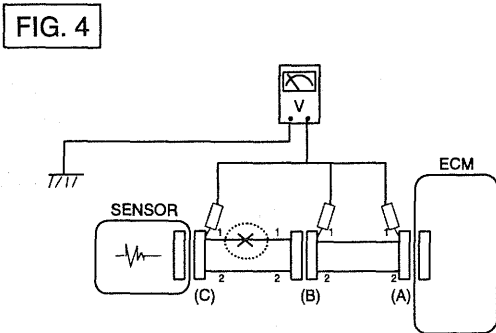

BFG501D

● CHECK SHORT CIRCUIT

- 1. Test Method for Short to Ground Circuit
 - Continuity Check with Chassis Ground

If short to ground circuit occurs as shown in [FIG. 5], the broken point can be found by performing below Step 2 (Continuity Check Method with Chassis Ground) as shown below.

FIG. 5

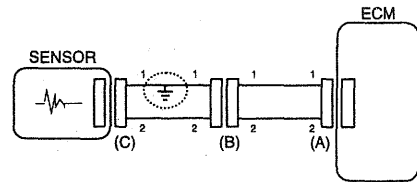

BFG501E

2. Continuity Check Method (with Chassis Ground)

NOTE

Lightly shake the wire harness above and below, or from side to side when measuring the resistance.

Specification (Resistance)

1Ω or less → Short to Ground Circuit

$1M\Omega$ or Higher → Normal Circuit

- a. Disconnect connectors (A), (C) and measure for resistance between connector (A) and Chassis Ground as shown in [FIG. 6].

The measured resistance of line 1 and 2 in this example is below 1Ω and higher than $1M\Omega$ respectively. Specifically the short to ground circuit is line 1 (Line 2 is normal). To find exact broken point, check the sub line of line 1 as described in the following step.

FIG. 6

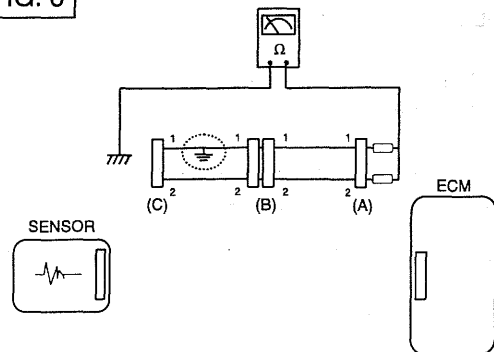

BFG501F

- b. Disconnect connector (B), and measure the resistance between connector (A) and chassis ground, and between (B1) and chassis ground as shown in [FIG. 7].

The measured resistance between connector (B1) and chassis ground is 1Ω or less. The short to ground circuit is between terminal 1 of connector (C) and terminal 1 of connector (B1).

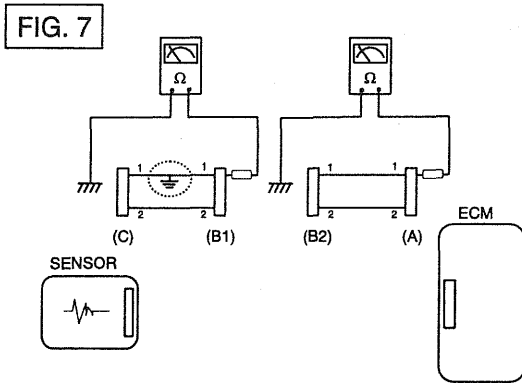

BFG501G

ECM PROBLEM INSPECTION PROCEDURE

1. **TEST ECM GROUND CIRCUIT:** Measure resistance between ECM and chassis ground using the backside of ECM harness connector as ECM side check point. If the problem is found, repair it.

Specification (Resistance): 1Ω or less

2. **TEST ECM CONNECTOR:** Disconnect the ECM connector and visually check the ground terminals on ECM side and harness side for bent pins or poor contact pressure. If the problem is found, repair it.
3. If problem is not found in Step 1 and 2, the ECM could be faulty. If so, replace the ECM with a new one, and then check the vehicle again. If the vehicle operates normally then the problem was likely with the ECM.
4. **RE-TEST THE ORIGINAL ECM :** Install the original ECM (may be broken) into a known-good vehicle and check the vehicle. If the problem occurs again, replace the original ECM with a new one. If problem does not occur, this is intermittent problem (Refer to INTERMITTENT PROBLEM PROCEDURE in BASIC INSPECTION PROCEDURE).

SYMPTOM TROUBLESHOOTING GUIDE CHART

Problem	Possible cause
Engine does not start	Run out of petrol
	Starter out of order
	Pump hose supply cut
	High pressure leakage
	Fuse out of order
	The compensation of individual injector not adapted
	Drift of the engine coolant temperature sensor not detected
	Drift of the rail pressure sensor not detected
	Cam and Crank signals missing simultaneously
	Battery voltage too low
	Faulty antitheft
	EGR valve blocked open (engine doesn't start)
	IMV contaminated, stuck, jammed
	Fuel quality / presence of water
	Inversion of low pressure fuel connections
	Fuel filter not adapted
	Low pressure fuel circuit sealed
	Sealed fuel filter
	Intermittent fault connection
	Air ingress in the low pressure fuel circuit
	Fuel return circuit of the pump sealed
	Air heaters out of order
	Engine compression too low
	Leakage at the injector valve
	Transfer pump out of order
	High pressure pump out of order
Injector jammed open	
Bug soft or hardware fault not detected	

Problem	Possible cause
Engine starts with difficulty or starts and stalls	Run out of petrol
	Fuel return hose of nozzle holder cut
	High pressure leakage
	Fuse out of order
	Air filter sealed
	Alternator or voltage regulator out of order
	The compensation of individual injector not adapted
	Drift of the engine coolant temperature sensor not detected
	Drift of the rail pressure sensor not detected
	Battery voltage too low
	EGR valve blocked open (engine doesn't start)
	IMV contaminated, stuck, jammed
	Fuel quality / presence of water
	Inversion of low pressure fuel connections
	Fuel filter not adapted
	Low pressure fuel circuit sealed
	Sealed fuel filter
	Oil level too high/too low
	Catalytic converter sealed or damaged
	Intermittent fault connection
	Air ingress in the low pressure fuel circuit
	Fuel return circuit of the pump sealed
	Air heaters out of order
	Engine compression too low
	Fuel return hose of nozzle holder sealed
	Carbon deposit on the injector (sealed holes)
	Needle stuck (injection possible over a certain pressure)
	Petrol in fuel
Bug soft or hardware fault not detected	

Problem	Possible cause
Poor starting when hot	The compensation of individual injector not adapted
	Drift of the rail pressure sensor not detected
	Drift of the engine coolant temperature sensor not detected
	EGR valve blocked open (engine doesn't start)
	IMV contaminated, stuck, jammed
	Air filter sealed
	Fuel filter not adapted
	Air ingress in the low pressure fuel circuit
	Fuel quality / presence of water
	Fuel return circuit of the pump sealed
	Sealed fuel filter
	Engine compression too low
	Intermittent fault connection
	Carbon deposit on the injector (sealed holes)
	Needle stuck (injection possible over a certain pressure)
	Petrol in fuel
Bug soft or hardware fault not detected	
Unstable idling	Fuel return hose of nozzle holder cut
	The compensation of individual injector not adapted
	Drift of the rail pressure sensor not detected
	Drift of the sensors used to evaluate the air flow not detected
	Harness resistance increased
	Fuel filter not adapted
	Air ingress in the low pressure fuel circuit
	Fuel quality / presence of water
	Sealed fuel filter
	Air filter sealed
	Fuel return hose of nozzle holder sealed
	High pressure leakage
	Air heaters out of order
	Engine compression too low
	Bad flanging of the injector
	High pressure pump out of order
	Injector not adapted
	Carbon deposit on the injector (sealed holes)
Needle stuck (injection possible over a certain pressure)	
Injector jammed open	

Problem	Possible cause
Idle speed too high/too low	Drift of the engine coolant temperature sensor not detected
	Incorrect state of the electrical pack devices
	Alternator or voltage regulator out of order
	Clutch not well set
	Bug soft or hardware fault not detected
Blue, white, black smokes	The compensation of individual injector not adapted
	Drift of the sensors used to evaluate the air flow not detected
	Drift of the engine coolant temperature sensor not detected
	Drift of the rail pressure sensor not detected
	EGR valve blocked open (engine doesn't start)
	IMV contaminated, stuck, jammed
	Oil level too high/too low
	Fuel quality / presence of water
	Catalytic converter sealed or damaged
	Air filter sealed
	Oil suction (engine racing)
	Air heaters out of order
	Engine compression too low
	Bad flanging of the injector
	Injector washer not adapted, forgotten, doubled
	Injector not adapted
	Carbon deposit on the injector (sealed holes)
Injector jammed open	
Petrol in fuel	
Engine rattling, noisy engine	The compensation of individual injector not adapted
	EGR valve blocked closed (noisy engine)
	EGR valve blocked open (engine doesn't start)
	Drift of the engine coolant temperature sensor not detected
	Drift of the sensors used to evaluate the air flow not detected
	Air heaters out of order
	Engine compression too low
	Fuel return hose of nozzle holder sealed
	Drift of the rail pressure sensor not detected
	Injector washer not adapted, forgotten, doubled
	Injector not adapted
	Carbon deposit on the injector (sealed holes)
	Needle stuck (injection possible over a certain pressure)
	Injector jammed open

Problem	Possible cause
Burst noise	The compensation of individual injector not adapted
	Intermittent fault connection
	Drift of the rail pressure sensor not detected
	IMV contaminated, stuck, jammed
	Bug soft or hardware fault not detected
Untimely acceleration/deceleration and engine racing	Pedal sensor blocked (cable jammed)
	EGR valve blocked open (engine doesn't start)
	Intermittent fault connection
	Oil suction (engine racing)
	Drift of the rail pressure sensor not detected
	Bug soft or hardware fault not detected
Gap when accelerating and at re-coupling (response time)	Air inlet circuit open
	Incorrect state of the electrical pack devices
	Pedal sensor blocked (cable jammed)
	EGR valve blocked open (engine doesn't start)
	Turbo charger damaged
	Fuel filter not adapted
	Sealed fuel filter
	Engine compression too low
	High pressure leakage
	IMV contaminated, stuck, jammed
	Needle stuck (injection possible over a certain pressure)
	Bug soft or hardware fault not detected

Problem	Possible cause
Engine stop/ stalling	Run out of petrol
	Pump hose supply cut
	High pressure leakage
	Fuse out of order
	Fuel quality / presence of water
	Low pressure fuel circuit sealed
	Sealed fuel filter
	Cam and Crank signals missing simultaneously
	EGR valve blocked open (engine doesn't start)
	IMV contaminated, stuck, jammed
	Alternator or voltage regulator out of order
	Intermittent fault connection
	Catalytic converter sealed or damaged
	Oil suction (engine racing)
	Transfer pump out of order
	High pressure pump out of order
	Faulty ignition key
	Petrol in fuel
Bug soft or hardware fault not detected	

Problem	Possible cause
Engine judder	Run out of petrol
	Fuel return hose of nozzle holder cut
	Incorrect state of the electrical pack devices
	The compensation of individual injector not adapted
	Drift of the sensors used to evaluate the air flow not detected
	EGR valve blocked open (engine doesn't start)
	Fuel filter not adapted
	Air ingress in the low pressure fuel circuit
	Fuel quality / presence of water
	Sealed fuel filter
	Intermittent fault connection
	Harness resistance increased
	Air heaters out of order
	Engine compression too low
	Fuel return hose of nozzle holder sealed
	Valve clearance
	Transfer pump out of order
	Injector washer not adapted, forgotten, doubled
	Carbon deposit on the injector (sealed holes)
	Needle stuck (injection possible over a certain pressure)
	Injector jammed open
Petrol in fuel	
Bug soft or hardware fault not detected	

Problem	Possible cause
Lack of power	The compensation of individual injector not adapted
	Pedal sensor blocked (cable jammed)
	Incorrect state of the electrical pack devices
	Drift of the sensors used to evaluate the air flow not detected
	EGR valve blocked open (engine doesn't start)
	Air inlet circuit open
	Air filter sealed
	Oil level too high/too low
	Catalytic converter sealed or damaged
	Turbo charger damaged
	Fuel filter not adapted
	Sealed fuel filter
	Leakage at the injector valve
	Fuel return circuit of the pump sealed
	Fuel return hose of nozzle holder sealed
	Engine compression too low
	Injector not adapted
Carbon deposit on the injector (sealed holes)	
Valve clearance	
Too much power	EGR valve blocked closed (noisy engine)
	The compensation of individual injector not adapted
	Oil suction (engine racing)
	Injector not adapted
	Bug soft or hardware fault not detected

Problem	Possible cause
Excessive fuel consumption	Fuel return hose of nozzle holder cut
	Leakage at the IMV
	Leakage at fuel temperature sensor
	Leakage at the spacers
	High pressure leakage
	Air inlet circuit open
	Air filter sealed
	The compensation of individual injector not adapted
	EGR valve blocked open (engine doesn't start)
	Incorrect state of the electrical pack devices
	Oil level too high/too low
	Fuel quality / presence of water
	Catalytic converter sealed or damaged
	Turbo charger damaged
	Engine compression too low
	Injector not adapted
Bug soft or hardware fault not detected	
Over speed engine when changing the gear box ratio	Pedal sensor blocked (cable jammed)
	The compensation of individual injector not adapted
	Intermittent fault connection
	Clutch not well set
	Oil suction (engine racing)
	Turbo charger damaged
	Injector not adapted
	Bug soft or hardware fault not detected
Exhaust smells	EGR valve blocked open (engine doesn't start)
	Oil suction (engine racing)
	Turbo charger damaged
	Oil level too high/too low
	The compensation of individual injector not adapted
	Catalytic converter sealed or damaged
	Bad flanging of the injector
	Injector washer not adapted, forgotten, doubled
	Injector not adapted
	Carbon deposit on the injector (sealed holes)
	Needle stuck (injection possible over a certain pressure)
	Injector jammed open Bug soft or hardware fault not detected

Problem	Possible cause
Smokes (black, white, blue) when accelerating	The compensation of individual injector not adapted
	EGR valve blocked open (engine doesn't start)
	Drift of the sensors used to evaluate the air flow not detected
	Air filter sealed
	Fuel quality / presence of water
	Oil level too high/too low
	Turbo charger damaged
	Catalytic converter sealed or damaged
	Oil suction (engine racing)
	Air heaters out of order
	Engine compression too low
	High pressure leakage
	Intermittent fault connection
	Bad flanging of the injector
	Injector washer not adapted, forgotten, doubled
	Injector not adapted
	Carbon deposit on the injector (sealed holes)
	Needle stuck (injection possible over a certain pressure)
	Injector jammed open
	Petrol in fuel
Bug soft or hardware fault not detected	
Fuel smells	Pump hose supply cut
	Fuel return hose of nozzle holder cut
	Leakage at the IMV
	Leakage at fuel temperature sensor
	Leakage at the spacers
	High pressure leakage

Problem	Possible cause
The engine collapses at take off	Pedal sensor blocked (cable jammed)
	Incorrect state of the electrical pack devices
	Air filter sealed
	Inversion of low pressure fuel connections
	Fuel filter not adapted
	Fuel quality/presence of water
	Air ingress in the low pressure fuel circuit
	Sealed fuel filter
	Catalytic converter sealed or damaged
	Clutch not well set
	Intermittent fault connection
	Drift of the rail pressure sensor not detected
	IMV contaminated, stuck, jammed
	Petrol in fuel
Bug soft or hardware fault not detected	
The engine does not stop	Faulty ignition key
	Oil suction (engine racing)
	Bug soft or hardware fault not detected
Different mechanical noises	Buzzer noise (discharge by the injectors)
	Clip broken (vibrations, resonance, noises)
	Incorrect state of the electrical pack devices
	Catalytic converter sealed or damaged
	Air inlet circuit open
	Bad flanging of the injector
	Clutch not well set
	Turbo charger damaged
Valve clearance	

DIESEL CONTROL SYSTEM

COMPONENTS EE257321

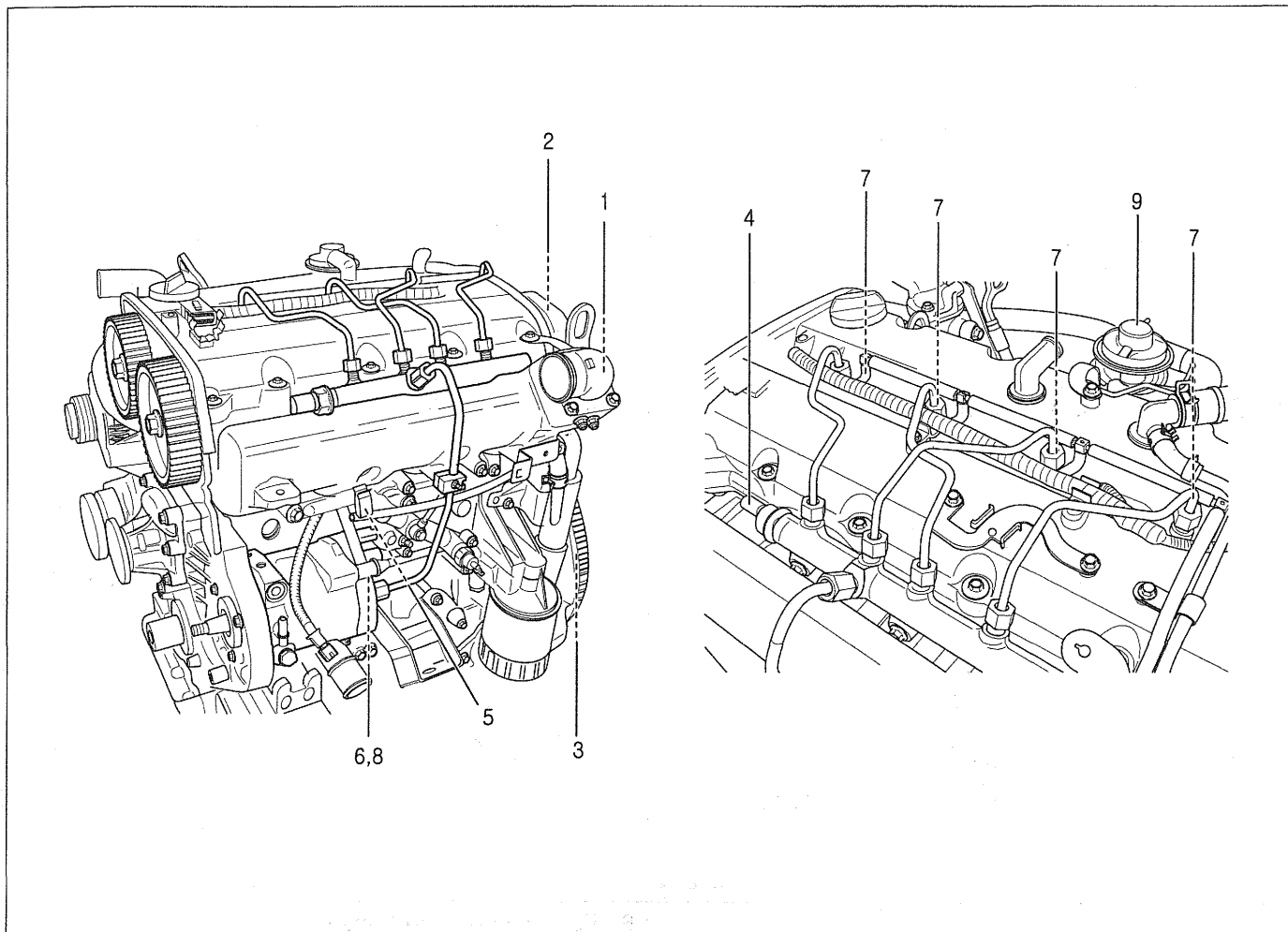

- | | |
|---|--|
| 1. Engine Coolant Temperature Sensor (ECTS) | 8. Inlet Metering Valve (IMV) |
| 2. Camshaft Position Sensor (CMPS) | 9. EGR Valve |
| 3. Crankshaft Position Sensor (CKPS) | 10. EGR Solenoid Valve |
| 4. Rail Pressure Sensor (RPS) | 11. Accelerator Position Sensor (APS) |
| 5. Knock Sensor (KS) | 12. Mass Air Flow Sensor (MAFS) |
| 6. Fuel Temperature Sensor (FTS) | 13. Intake Air Temperature Sensor (IATS) |
| 7. Injector | |

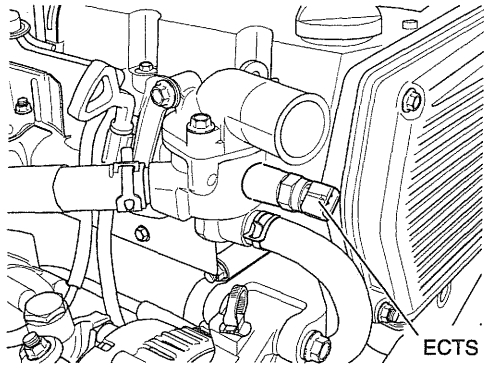
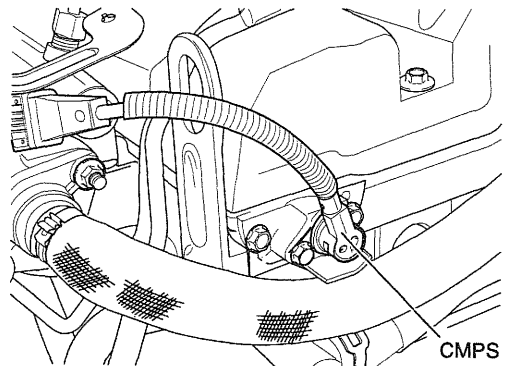
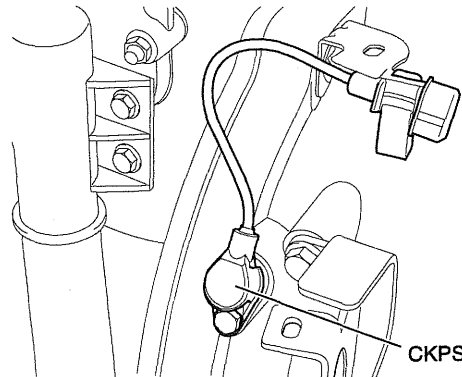
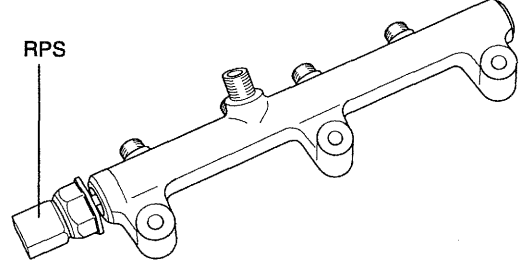
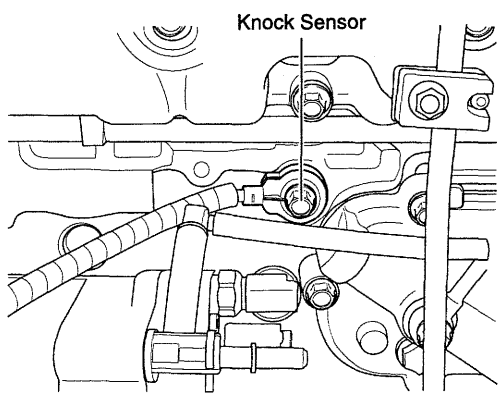
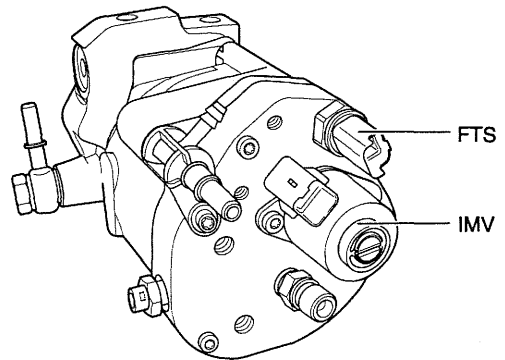
<p>1. Engine Coolant Temperature Sensor (ECTS)</p>  <p>ECTS</p> <p>AFBE100G</p>	<p>2. Camshaft Position Sensor (CMPS)</p>  <p>CMPS</p> <p>AFBE100H</p>
<p>3. Crankshaft Position Sensor (CKPS)</p>  <p>CKPS</p> <p>AFBE100I</p>	<p>4. Rail Pressure Sensor (RPS)</p>  <p>RPS</p> <p>AFBE100J</p>
<p>5. Knock Sensor (KS)</p>  <p>Knock Sensor</p> <p>EWMF100K</p>	<p>6. Fuel Temperature Sensor (FTS) 8. Inlet Metering Valve (IMV)</p>  <p>FTS</p> <p>IMV</p> <p>AFBE100L</p>

7. Injector

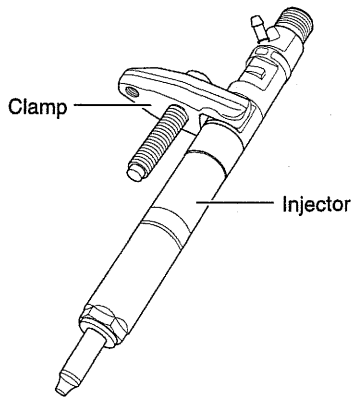

EWMF100M

9. Accelerator Position Sensor (APS)

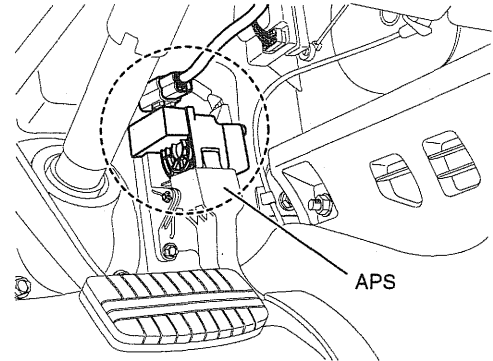

KFME100P

**10. Mass Air Flow Sensor (MAFS)
11. Intake Air Temperature Sensor (IATS)**

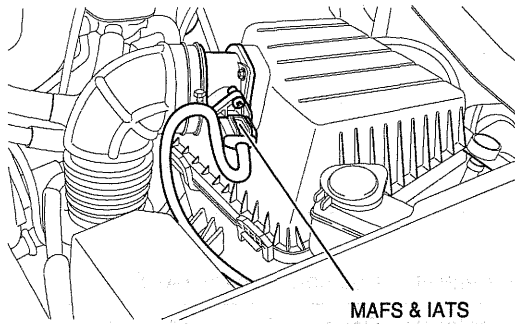

KFME100Q

ECM CONNECTOR E0AE603B

ECM Harness Connector

1	5	9	13	17	21	25	29
2	6	10	14	18	22	26	30
3	7						
		11	15	19	23	27	31
4	8	12	16	20	24	28	32

E03-1

33	37	41	45	49	53	57	61	65	69	73	77
34	38	42	46	50	54	58	62	66	70	74	78
35	39										
		43	47	51	55	59	63	67	71	75	79
36	40	44	48	52	56	60	64	68	72	76	80

E03-2

81	85	89	93	97	101	105	109
82	86	90	94	98	102	106	110
						107	111
83	87	91	95	99	103		
84	88	92	96	100	104	108	112

E03-3

EWMF100A

CONNECTOR [E03-1]

Pin	Function	Connected to
1	-	
2	Accelerator position sensor signal input 1	Accelerator Position Sensor (APS) 1
3	Sensor ground	Accelerator Position Sensor (APS) 1
4	Power ground	Chassis Ground
5	Power supply (Battery voltage)	Main Relay
6	Sensor power supply	Accelerator Position Sensor (APS) 1
7	-	
8	Power ground	Chassis Ground
9	Malfunction indicator lamp control output	Cluster
10	Sensor power supply	Accelerator Position Sensor (APS) 2
11	Accelerator position sensor signal input 2	Accelerator Position Sensor (APS) 2
12	Sensor ground	Accelerator Position Sensor (APS) 2
13	-	
14	Immobilizer lamp control output	Cluster
15		
16	Brake switch 1 signal input	Brake Switch
17	Ignition switch sense	Ignition Switch
18	-	
19	-	
20	-	
21	Auto cruise indicator lamp control output	Auto Cruise Indicator Lamp
22	-	
23	-	
24	Clutch switch (M/T only)	Clutch Switch
25	-	
26	Engine speed signal output	Cluster
27	Immobilizer diagnosis line	Immobilizer

Pin	Function	Connected to
28	Diagnosis line (K-LINE)	Data Link Connector (DLC)
29	Glow indicator lamp control output	Cluster
30	A/T: P/N switch signal input	Inhibitor switch
	M/T: 1st gear switch signal input	1st Gear Switch
31	CAN - LOW	TCM
32	CAN - HIGH	TCM

CONNECTOR [E03-2]

Pin	Function	Connected to
33	Sensor shield	Knock Sensor (KS)
34	-	
35	Intake throttle solenoid valve control output	Intake Throttle Solenoid Valve
36	Inlet metering valve control output	Inlet Metering Valve (IMV)
37	Sensor shield	Crankshaft Position Sensor (CKPS)
38	Water indicator lamp control output	Cluster
39	EGR solenoid valve control output	EGR Solenoid Valve
40	-	
41	-	
42	Intake air temperature sensor signal input	Intake Air Temperature Sensor (IATS)
43	-	
44	-	
45	-	
46	Glow relay 2 diagnosis line	Glow Relay 2
47	-	
48	-	
49	-	
50	Engine coolant temperature sensor signal input	Engine Coolant Temperature Sensor (ECTS)
51	Sensor ground	Engine Coolant Temperature Sensor (ECTS)
52	Injector (Cylinder #4) Low	Injector (Cylinder #4)
53	Knock sensor signal input	Knock Sensor (KS)
54	Fuel temperature sensor signal input	Fuel Temperature Sensor (FTS)
55	Sensor ground	Fuel Temperature Sensor (FTS)
56	Injector (Cylinder #4) High	Injector (Cylinder #4)
57	Sensor ground	Knock Sensor (KS)
58	Crankshaft position sensor [+] signal input	Crankshaft Position Sensor (CKPS)
59	Crankshaft position sensor [-] signal input	Crankshaft Position Sensor (CKPS)
60	Injector (Cylinder #3) Low	Injector (Cylinder #3)
61	Sensor power supply	Camshaft Position Sensor (CMPS)
62	Camshaft position sensor signal input	Camshaft Position Sensor (CMPS)

Pin	Function	Connected to
63	Sensor ground	Camshaft Position Sensor (CMPS)
64	Injector (Cylinder #3) High	Injector (Cylinder #3)
65	Sensor power supply	Rail Pressure Sensor (RPS)
66	Rail pressure sensor signal input	Rail Pressure Sensor (RPS)
67	Sensor ground	Rail Pressure Sensor (RPS)
68	Injector (Cylinder #2) Low	Injector (Cylinder #2)
69	-	
70	-	
71	-	
72	Injector (Cylinder #2) High	Injector (Cylinder #2)
73	-	
74	-	
75	-	
76	Injector (Cylinder #1) Low	Injector (Cylinder #1)
77	Sensor power supply	Mass Air Flow Sensor (MAFS)
78	Mass air flow sensor signal input	Mass Air Flow Sensor (MAFS)
79	Sensor ground	Mass Air Flow Sensor (MAFS)
		Intake Air Temperature Sensor (IATS)
80	Injector (Cylinder #1) High	Injector (Cylinder #1)

CONNECTOR [E03-3]

Pin	Function	Connected to
81	-	
82	-	
83	-	
84	Compressor fan relay control output	Compressor Fan Relay
85	-	
86	Brake switch 2 signal input	Brake Switch
87	-	
88	-	
89	Auto cruise switch signal input	Auto Cruise Switch
90	-	
91	Glow relay 1 control output	Glow Relay 1
92	-	
93	Blower switch signal input	Blower switch
94	Glow relay 1 diagnosis line	Glow Relay 1
95	Glow relay 2 control output	Glow Relay 2
96	-	
97	MT/AT switch signal input	A/T: Chassis Ground, M/T: not used
98	Torque reduction signal input	TCM
99	A/C switch signal input	A/C Switch
100	Vehicle speed sensor signal input	Vehicle Speed Sensor (VSS)
101	-	
102	Water sensor signal input	Water Sensor in Fuel Filter
103	Accelerator position signal input (4WD only)	4WD: TOD (Torque On Demand), A/T: TCM
104	Main relay control output	Main Relay
105	A/C relay control output	A/C Relay
106	-	
107	Power supply (Battery voltage)	Main Relay
108	Power ground	Chassis Ground
109	-	
110	-	
111	Power supply (Battery voltage)	Main Relay
112	Power ground	Chassis Ground

DTC TROUBLESHOOTING PROCEDURES

INSPECTION CHART FOR DIAGNOSTIC TROUBLE CODES (DTC) E6EB026F

DTC	CC - CODE	Description	MIL
P0100		EGR Control Malfunction	△
	04	Parameter at minimum limit	
	05	Parameter at maximum limit	
P0101		Mass Air Flow Sensor (MAFS) Circuit Malfunction	△
	0a	Signal low (Open circuit or short circuit to ground)	
	0b	Signal high (Short circuit to battery line)	
P0102		Mass Air Flow Sensor (MAFS) Range/Performance Problem	△
	04	Signal lower than lower limit	
	05	Signal higher than upper limit	
P0115		Engine Coolant Temperature Sensor (ECTS) Circuit Malfunction	△
	0b	Signal low (Open circuit or short circuit to battery line)	
	02	Signal high (Short circuit to ground)	
P0120		Accelerator Position Sensor (APS) 1 Circuit Malfunction	△
	0a	Signal low (Open circuit or short circuit to ground)	
	0b	Signal high (Short circuit to battery line)	
	06	Value incoherent	
P0180		Fuel Temperature Sensor (FTS) Circuit Malfunction	△
	0b	Signal low (Open circuit or short circuit to battery line)	
	02	Signal high (Short circuit to ground)	
P0190		Rail Pressure Sensor (RPS) Range/Performance Problem	△
	0a	Signal low (Short circuit to ground)	
	0b	Signal high (Open circuit or short circuit to battery line)	
	06	Rail pressure incoherent	
	08	Signal low	
	09	Signal high	
	05	Parameter at maximum limit	
	8d	Above the average threshold	

DTC	CC - CODE	Description	MIL
P0201		Inector #1 (Cylinder #1) Circuit Malfunction	△
	04	Signal low	
	91	Injector stuck (Open)	
	86	Injector stuck (Close)	
	01	Open Circuit	
	0c	Short Circuit	
P0202		Inector #2 (Cylinder #3) Circuit Malfunction	△
	04	Signal low	
	91	Injector stuck (Open)	
	86	Injector stuck (Close)	
	01	Open Circuit	
	0c	Short Circuit	
P0203		Inector #3 (Cylinder #4) Circuit Malfunction	△
	04	Signal low	
	91	Injector stuck (Open)	
	86	Injector stuck (Close)	
	01	Open Circuit	
	0c	Short Circuit	
P0204		Inector #4 (Cylinder #2) Circuit Malfunction	△
	04	Signal low	
	91	Injector stuck (Open)	
	86	Injector stuck (Close)	
	01	Open Circuit	
	0c	Short Circuit	
P0220		Accelerator Position Sensor (APS) 2 Circuit Malfunction	△
	0a	Signal low (Open circuit or short circuit to ground)	
	0b	Signal high (Short circuit to battery line)	
	02	Signal low	
	03	Signal high	
P0226		Accelerator Position Sensor (APS) 2 Range/Performance Problem	△
	06	APS 1/2 signal incoherent	
	0b	Abnormal signal	
P0325		Knock Sensor Circuit Malfunction	△
	09	Signal high	
	07	No signal	

DTC	CC - CODE	Description	MIL
P0335		Crankshaft Position Sensor (CKPS) Circuit Malfunction	△
	93	Too many extra teeth detected	
	95	Extra teeth detected	
	07	No signal	
	94	Missing teeth detected	
	06	Abnormal airgap	
	92	Too many missing teeth detected	
P0340		Camshaft Position Sensor (CMPS) Circuit Malfunction	△
	07	No signal	
	06	CMPS/CKPS signal incoherent	
P0380		Glow Relay 1 Circuit Malfunction	△
	0a	Signal low (Open circuit or short circuit to ground)	
	03	Signal high (Short circuit to battery line)	
	0a	Open circuit or short circuit to ground	
	03	Short circuit to battery line	
P0381		Glow Indicator Lamp Circuit Malfunction	△
	0a	Open circuit or short circuit to ground	
	03	Short circuit to battery line	
P0382		Glow Relay 2 Circuit Malfunction	△
	0a	Signal low (Open circuit or short circuit to ground)	
	03	Signal high (Short circuit to battery line)	
	0a	Open circuit or short circuit to ground	
	03	Short circuit to battery line	
P0400		EGR Solenoid Valve Circuit Malfunction	△
	0a	Open circuit or short circuit to ground	
	03	Short circuit to battery line	
P0560		Battery Voltage Malfunction	△
	08	Battery voltage too low	
	09	Battery voltage too high	
P0600		CAN Communication Error	△
	07	No signal	
	06	No signal or TCM error	
	0a	No signal or TCS(or ESP) error	
P0650		Malfunction Indicator Lamp Circuit Malfunction	△
	0a	Open circuit or short circuit to ground	
	03	Short circuit to battery line	

DTC	CC - CODE	Description	MIL
P1119		Inlet Metering Valve (IMV) Control Malfunction	△
	96	Fuel leakage	
	97	Fuel leakage	
	98	Fuel leakage	
	99	Fuel leakage	
P1120		Inlet Metering Valve (IMV) Circuit Malfunction	△
	0a	Open circuit or short circuit to ground	
	03	Short circuit to battery line	
	05	Fuel leakage	
	04	Fuel leakage	
	08	Fuel leakage	
P1140		Intake Air Temperature Sensor (IATS) Circuit Malfunction	△
	0b	Signal low (Open circuit or short circuit to battery line)	
	02	Signal high (Short circuit to ground)	
P1150		Atmospheric Pressure Sensor Fault	△
	0a	Signal low (Open circuit or short circuit to ground)	
	03	Signal high (Short circuit to battery line)	
P1190		Throttle Drive Fault	△
	0a	Signal low (Open circuit or short circuit to ground)	
	03	Signal high (Short circuit to battery line)	
P1300		Injector Specific Data Fault	△
	04	Injector parameters incorrect	
P1310		Injector Control Circuit Fault	△
	03	Short circuit to battery line	
	02	Short circuit to ground	
P1458		A/C Switch Fault	△
	06	Value incoherent	
P1500		Vehicle Speed Sensor (VSS) Circuit Malfunction	△
	06	Abnormal signal after running	
	06	Abnormal signal after running	
	06	Abnormal signal after running	
	07	No signal before running	
P1543		Brake Switch Signal Fault	△
	03	Short to battery line in brake switch 1 circuit	
	02	Short to ground in brake switch 1 circuit	
	0b	Short to battery line in brake switch 2 circuit	
	0a	Short to ground in brake switch 2 circuit	
	0c	Brake 1/2 signal incoherent	

DTC	CC - CODE	Description	MIL
P1603		CAN BUS OFF	△
	07	CAN BUS OFF Fault	
P1608		ECM Fault	△
	81	ECM internal fault	
	82	ECM internal fault	
	82	ECM internal fault	
	82	ECM internal fault	
P1610		Sensor External Voltage Fault	△
	08	Sensor supply voltage too low	
	09	Sensor supply voltage too high	
P1614		ECM Programming Error	△
	85	ECM internal fault	
	83	ECM internal fault	
	8b	ECM internal fault	
	88	ECM internal fault	
	87	ECM internal fault	
	8a	ECM internal fault	
	8c	ECM internal fault	
	8a	ECM internal fault	
P1620		A/C Relay Circuit Malfunction	△
	0a	Open circuit or short circuit to ground	
	03	Short circuit to battery line	
P1640		Main Relay Circuit Malfunction	●
	0a	Open circuit or short circuit to ground	
P1674		A/C Fan Relay Circuit Malfunction	●
	0a	Open circuit or short circuit to ground	
P1780		Torque Reduction Signal Fault	△
	06	Abnormal signal	
	09	Abnormal signal	
	0a	Signal low (Open circuit or short circuit to ground)	
	0b	Signal high (Short circuit to battery line)	
P1786		Tachometer Output Fault	△
	0a	Signal low (Short circuit to ground)	
P2264		Water Sensor Circuit Malfunction	△
	0b	Permanent low level	

DTC	CC - CODE	Description	MIL
P2269		Water in Fuel Filter Indicator Lamp Circuit Malfunction	△
	0a	Signal low (Open circuit or short circuit to ground)	
	03	Signal high (Short circuit to battery line)	

 **NOTE**

- : MIL ON & FAULT CODE MEMORY
- △ : MIL OFF & FAULT CODE MEMORY

 **NOTE**

- Refer to the Group "BE" for the troubleshooting procedures of DTC P1611, P1612, P1613 and P1626.
- Refer to the Group "EE" for the troubleshooting procedures of DTC P1660 and P1661.

TROUBLESHOOTING FOR DTC E4392AED

DTC	P0100	EGR Control Malfunction
CC-CODE	04	Parameter at minimum limit
	05	Parameter at maximum limit

DTC DETECTING CONDITION

CC-CODE	Detecting Condition	Suspect Area
04	<ul style="list-style-type: none"> • (Target intake air mass - Actual intake air mass) < 200 mg/stroke 	<ul style="list-style-type: none"> • EGR valve • EGR solenoid valve • Pipe connecting EGR valve and exhaust manifold • ECM
05	<ul style="list-style-type: none"> • (Target intake air mass - Actual intake air mass) > 900 mg/stroke 	

INSPECTION PROCEDURE

1. CHECK DTC

1. Connect the Hi-Scan (Pro) to the Data Link Connector (DLC).
2. Turn ignition switch to ON and check that any other DTC(s) is (are) detected.

Is P0400 also set?

No

Yes	Do all repairs associated with those codes before proceeding with this procedure.
-----	---

2. EGR VALVE INSPECTION

1. Inspect below items.
 - EGR valve
 - Pipe connecting EGR valve and exhaust manifold

Are all items have normal condition?

Yes

No	Repair or replace it.
----	-----------------------

Proceed with "ECM PROBLEM INSPECTION PROCEDURE" in BASIC INSPECTION PROCEDURE.

TROUBLESHOOTING FOR DTC EFED28F4

DTC	P0101	Mass Air Flow Sensor (MAFS) Circuit Malfunction
CC-CODE	0a	Signal low (Open circuit or short circuit to ground)
	0b	Signal high (Short circuit to battery line)

DTC	P0102	Mass Air Flow Sensor (MAFS) Range/Performance Problem
CC-CODE	04	Signal lower than lower limit
	05	Signal higher than upper limit

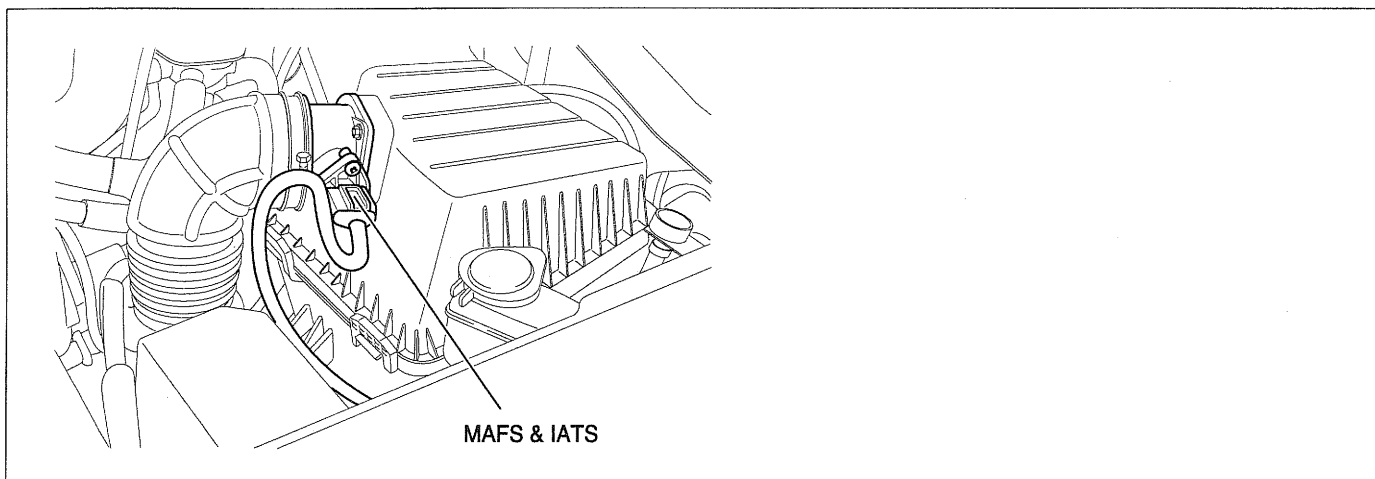

KFME200N

DESCRIPTION

The mass air flow sensor (MAFS) has an intake air temperature sensor built-in and is located between the air cleaner assembly and the throttle device. The MAFS uses a hot film type sensing-element to measure the mass of intake air entering the engine. Mass air flow rate is measured by detection of heat transfer from a hot film probe. The change in air flow rate causes change in the amount of heat being transferred from the hot film probe surface to

the air flow. A large amount of intake air represents acceleration or high load conditions while a small amount of intake air represents deceleration or idle. The ECM uses this information to control the EGR solenoid valve and correct the fuel amount.

DTC DETECTING CONDITION

CC-CODE	Detecting Condition	Suspect Area
0a	• Mass air flow < 50 mg/stroke	<ul style="list-style-type: none"> • Open or short in MAFS circuit • MAFS • ECM
0b	• Mass air flow > 1,000 mg/stroke	
04	• Mass air flow sensor fault	
05		

[SCHEMATIC DIAGRAM]

[CIRCUIT DIAGRAM]

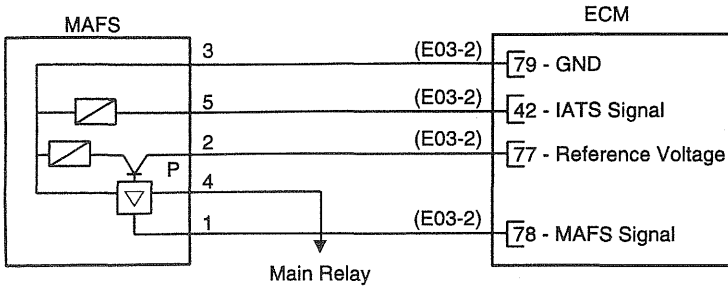

[CONNECTION INFORMATION]

Terminal	Connected to	Function
1	ECM E03-2 (78)	MAFS Signal
2	ECM E03-2 (77)	Reference Voltage
3	ECM E03-2 (79)	Sensor Ground
4	Main Relay	Battery Voltage
5	ECM E03-2 (42)	IATS Signal

[HARNESS CONNECTORS]

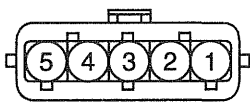

E17
MAFS & IATS

33	37	41	45	49	53	57	61	65	69	73	●
34	38	●	46	50	54	58	62	66	70	74	●
35	39										
		43	47	51	55	59	63	67	71	75	●
36	40	44	48	52	56	60	64	68	72	76	80

E03-2
ECM

INSPECTION PROCEDURE

1. CHECK MAFS AND ECM CONNECTORS

1. Thoroughly check connectors for looseness, poor connection, bending, corrosion, contamination, deterioration, or damage.
 - Refer to "CONNECTOR INSPECTION PROCEDURE" in BASIC INSPECTION PROCEDURE.

Are all connectors good?

Yes		
	No	Repair or replace it

2. CHECK POWER TO MAFS

1. Turn ignition switch to OFF and disconnect MAFS connector.
2. Turn ignition switch to ON.
3. Measure voltage in harness between terminal 4 of MAFS harness connector and chassis ground.
 - **Specification: approximately B+**

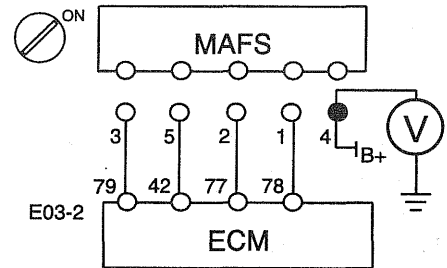

Is(Are) voltage(s) within specification?

Yes		
	No	Repair open or short circuit in harness.

3. CHECK FOR OPEN IN HARNESS

1. Turn ignition switch to OFF, and then disconnect ECM and MAFS connector.
2. Measure resistance between terminal 1 of MAFS harness connector and terminal E03-2(78) of ECM harness connector.
3. Measure resistance between terminal 3 of MAFS harness connector and terminal E03-2(79) of ECM harness connector.
 - **Specification: below 1Ω**

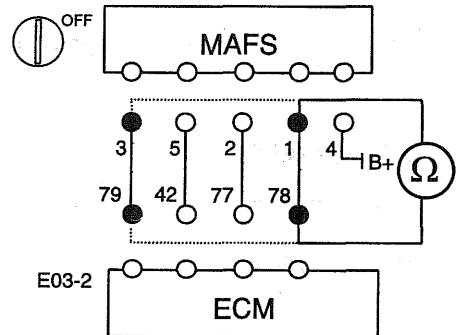

Is(Are) resistance(s) within specification?

Yes		
	No	Repair open circuit in harness.

4. CHECK FOR SHORT TO GROUND IN HARNESS

1. Turn ignition switch to OFF, and then disconnect ECM and MAFS connector.
2. Measure resistance between terminal 1 of MAFS harness connector and chassis ground.
3. Measure resistance between terminal 1 and 3 of MAFS harness connector.
 - **Specification: infinite**

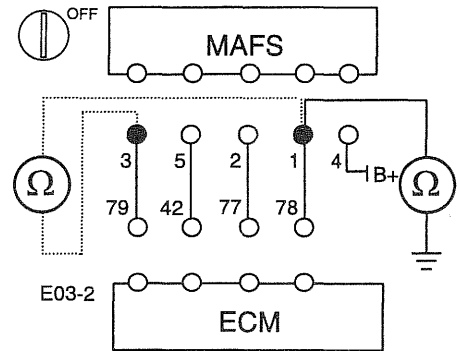

Is(Are) resistance(s) within specification?

Yes

No	Repair short or short to chassis ground in harness.
----	---

5. CHECK FOR SHORT TO POWER IN HARNESS

1. Turn ignition switch to OFF, and then disconnect ECM and MAFS connector.
2. Turn ignition switch to ON.
3. Measure voltage between terminal 1 of MAFS harness connector and chassis ground.
 - **Specification: below 0.5V**

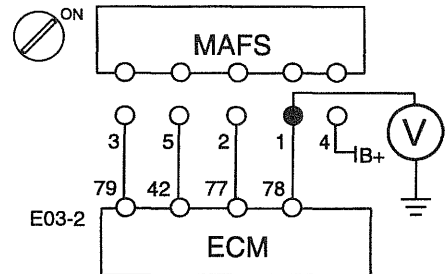

Is(Are) voltage(s) within specification?

Yes

No	Repair short to power in harness.
----	-----------------------------------

6. CHECK MAFS

1. Replace the MAFS with a new one, and then monitor the vehicle again using a Hi-Scan (Pro).

Are these problem fixed?

Yes

No	Replace the MAFS.
----	-------------------

Proceed with "ECM PROBLEM INSPECTION PROCEDURE" in BASIC INSPECTION PROCEDURE.

TROUBLESHOOTING FOR DTC E91DF16A

DTC	P0115	Engine Coolant Temperature Sensor (ECTS) Circuit Malfunction
CC-CODE	0b	Signal low (Open circuit or short circuit to battery line)
	02	Signal high (Short circuit to ground)

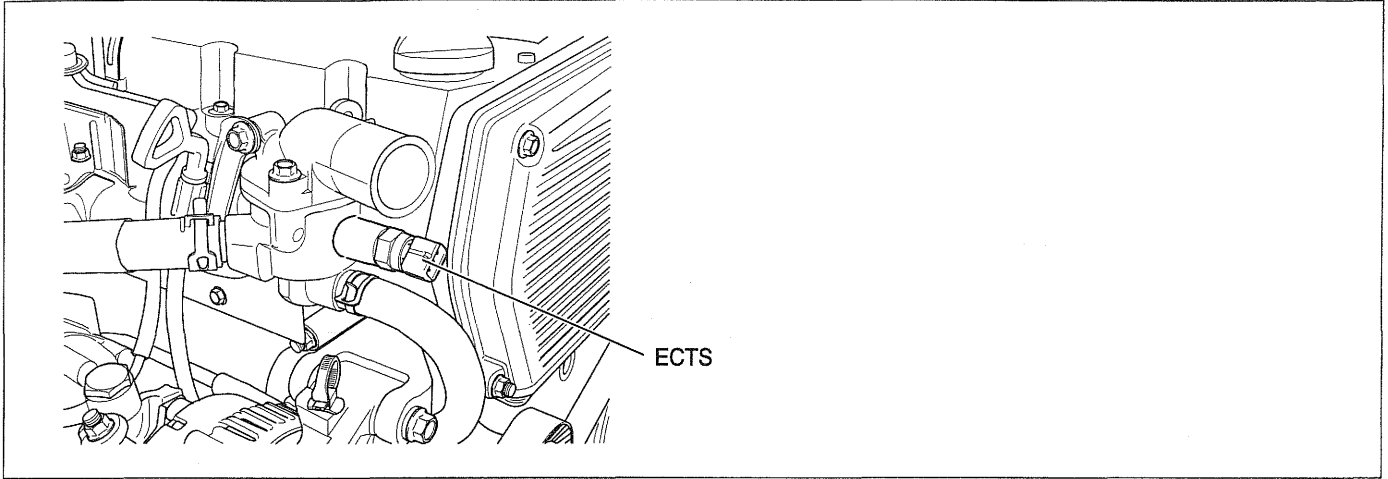

AFBE2000

DESCRIPTION

The engine coolant temperature sensor (ECTS) is located in the engine coolant passage of the cylinder head for detecting the engine coolant temperature. The ECTS uses a thermistor whose resistance changes with the temperature. The electrical resistance of the ECTS decreases as the engine coolant temperature increases, and increases as the engine coolant temperature decreases. The 5 V power source in the ECM is supplied to the ECTS via a resistor in the ECM. That is, the resistor in the ECM and

the thermistor in the ECTS are connected in series. When the resistance value of the thermistor in ECTS changes according to the engine coolant temperature, the signal voltage also changes. This information of engine coolant temperature is used in determination of basic fuel quantity and cooling fan control.

DTC DETECTING CONDITION

CC-CODE	Detecting Condition	Suspect Area
0b	• Engine coolant temperature < -49°C(-56.2°F)	<ul style="list-style-type: none"> • Open or short in ECTS circuit • ECTS • ECM
02	• Engine coolant temperature > 139°C(282.2°F)	

SPECIFICATION

Temperature [°C (°F)]	-40(-40)	-20(-4)	0(32)	20(68)	40(104)	60(140)	80(176)
Resistance (kΩ)	44.4	13.4 ~ 16.8	5.74	2.3 ~ 2.6	1.15	0.58	0.32

[SCHEMATIC DIAGRAM]

[CIRCUIT DIAGRAM]

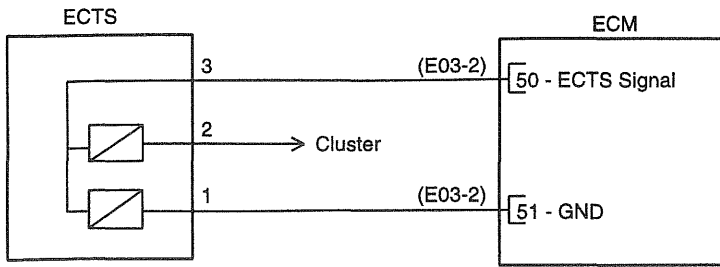

[CONNECTION INFORMATION]

Terminal	Connected to	Function
1	ECM E03-2 (51)	Sensor Ground
2	Cluster	-
3	ECM E03-2 (50)	ECTS Signal

[HARNES CONNECTORS]

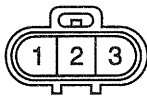

E43

ECTS

33	37	41	45	49	53	57	61	65	69	73	77
34	38	42	46	50	54	58	62	66	70	74	78
35	39	43	47	51	55	59	63	67	71	75	79
36	40	44	48	52	56	60	64	68	72	76	80

E03-2

ECM

INSPECTION PROCEDURE

1. CHECK ECTS AND ECM CONNECTORS

1. Thoroughly check connectors for looseness, poor connection, bending, corrosion, contamination, deterioration, or damage.
 - Refer to "CONNECTOR INSPECTION PROCEDURE" in BASIC INSPECTION PROCEDURE.

Are all connectors good?

Yes		
No		Repair or replace it.

2. CHECK REFERENCE VOLTAGE TO ECTS

1. Turn ignition switch to OFF and disconnect ECTS connector.
2. Turn ignition switch to ON.
3. Measure voltage in harness between terminal 3 of ECTS harness connector and chassis ground.
 - **Specification: approximately 5V**

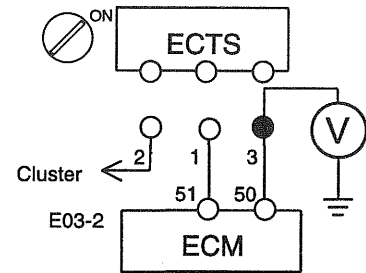

Is(Are) voltage(s) within specification?

Yes		
No		Repair open or short circuit in harness.

3. CHECK FOR OPEN IN HARNESS

1. Turn ignition switch to OFF, and then disconnect ECM and ECTS connector.
2. Measure resistance between terminal 3 of ECTS harness connector and terminal E03-2(50) of ECM harness connector.
3. Measure resistance between terminal 1 of ECTS harness connector and terminal E03-2(51) of ECM harness connector.
 - **Specification: below 1Ω**

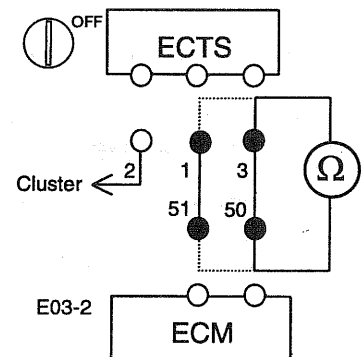

Is(Are) resistance(s) within specification?

Yes		
No		Repair open circuit in harness.

4. CHECK FOR SHORT TO GROUND IN HARNESS

1. Turn ignition switch to OFF, and then disconnect ECM and ECTS connector.
2. Measure resistance between terminal 3 of ECTS harness connector and chassis ground.
3. Measure resistance between terminal 3 and 1 of ECTS harness connector.
 - **Specification: infinite**

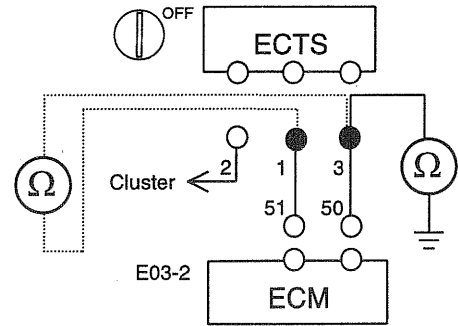

Is(Are) resistance(s) within specification?

Yes

No	Repair short or short to chassis ground in harness.
----	---

5. CHECK FOR SHORT TO POWER IN HARNESS

1. Turn ignition switch to OFF, and then disconnect ECM and ECTS connector.
2. Turn ignition switch to ON.
3. Measure voltage between terminal 3 of ECTS harness connector and chassis ground.
 - **Specification: below 0.5V**

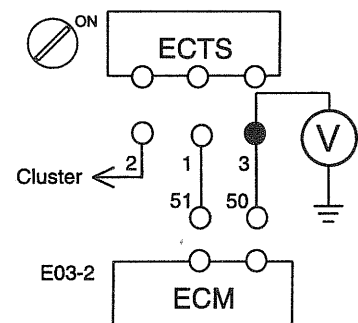

Is(Are) voltage(s) within specification?

Yes

No	Repair short to power in harness.
----	-----------------------------------

6. CHECK ECTS RESISTANCE

1. Turn ignition switch to OFF and disconnect ECTS connector.
2. Measure resistance between terminal 3 and 1 of ECTS connector.
 - **Refer to "SPECIFICATION" for more information.**

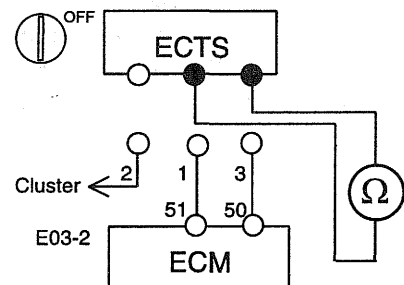

Is(Are) resistance(s) within specification?

Yes

No	Replace the ECTS.
----	-------------------

Proceed with "ECM PROBLEM INSPECTION PROCEDURE" in BASIC INSPECTION PROCEDURE.

TROUBLESHOOTING FOR DTC ECAFD836

DTC	P0120	Accelerator Position Sensor (APS) 1 Circuit Malfunction
CC-CODE	0a	Signal low (Open circuit or short circuit to ground)
	0b	Signal high (Short circuit to battery line)
	06	Value incoherent

DTC	P0220	Accelerator Position Sensor (APS) 2 Circuit Malfunction
CC-CODE	0a	Signal low (Open circuit or short circuit to ground)
	0b	Signal high (Short circuit to battery line)
	02	Signal low
	03	Signal high

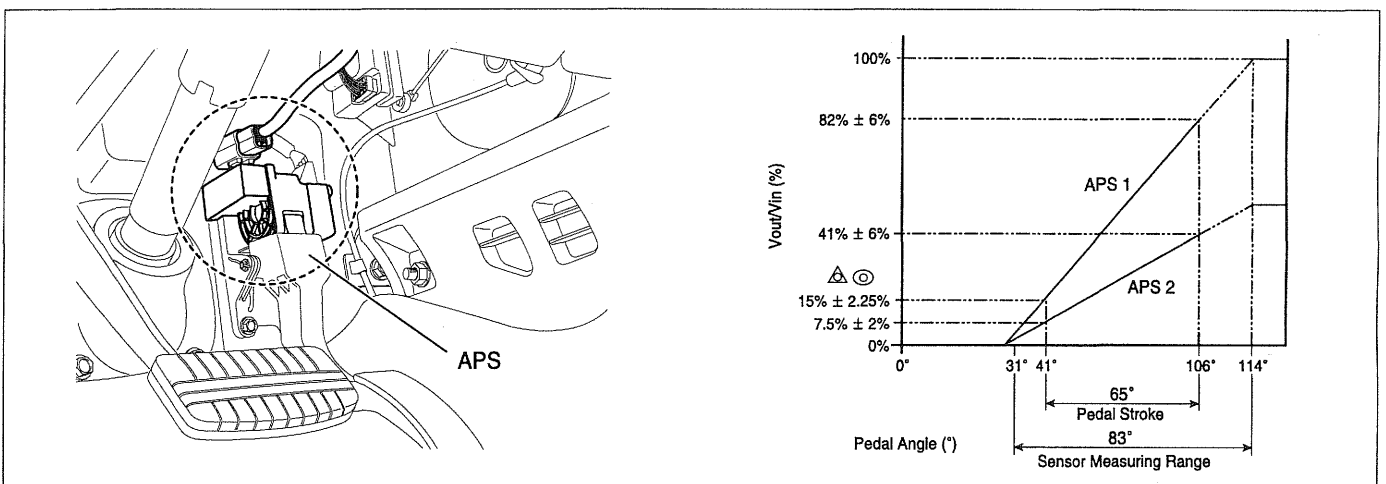

EWMF200P

DESCRIPTION

On electronic injection systems, there is no longer a load lever that mechanically controls the fuelling. The flow is calculated by the ECM depending on a number of parameters, including pedal position, which is measured using a potentiometer. The absence of a mechanical link between the accelerator pedal and the injection system presents a risk of loss of control of the engine in the event of a failure of the component in charge of providing the driver's request information to the injection system. The pedal sensor therefore has two potentiometers whose slides are mechanically solid. The two potentiometers are supplied from

distinct and different power sources so there is built in redundancy of information giving reliable driver's request information.

A voltage is generated across the potentiometer in the acceleration position sensor as a function of the accelerator-pedal setting. Using a programmed characteristic curve, the pedal's position is then calculated from this voltage.

DTC DETECTING CONDITION

(P0120)

CC-CODE	Detecting Condition	Suspect Area
0a	• Accelerator pedal angle (APS 1) < 4%	<ul style="list-style-type: none"> • Open or short in APS circuit • APS • ECM
0b	• Accelerator pedal angle (APS 1) > 95%	
06	• Accelerator pedal angle (APS 1) - Accelerator pedal angle (APS 2) > 8%	

(P0220)

CC-CODE	Detecting Condition	Suspect Area
0a	• Accelerator pedal angle (APS 2) < 2%	<ul style="list-style-type: none"> • Open or short in APS circuit • APS • ECM
0b	• Accelerator pedal angle (APS 2) > 49.5%	
02	• Sensor supply voltage < 3.17V	
03	• Sensor supply voltage > 4.63V	

SPECIFICATION

Condition	C.T	W.O.T
Pedal Angle	41°	106°
Vout/Vin (%)	APS 1	14.66 ~ 15.34%
	APS 2	7.35 ~ 7.65%
		77.08 ~ 86.92%
		38.5 ~ 43.5%

[SCHEMATIC DIAGRAM]

[CIRCUIT DIAGRAM]

[CONNECTION INFORMATION]

Terminal	Connected to	Function
1	ECM E03-1 (11)	APS 2 Signal
2	ECM E03-1 (2)	APS 1 Signal
3	ECM E03-1 (10)	Reference Voltage
4	ECM E03-1 (12)	Sensor Ground
5	ECM E03-1 (3)	Sensor Ground
6	ECM E03-1 (6)	Reference Voltage

[HARNESS CONNECTORS]

M07
ECTS

1	5	9	13	17	21	25	29
●	●	●	14	18	22	26	30
●	7	●	15	19	23	27	31
4	8	●	16	20	24	28	32

E03-1
ECM

INSPECTION PROCEDURE

1. CHECK APS AND ECM CONNECTORS

1. Thoroughly check connectors for looseness, poor connection, bending, corrosion, contamination, deterioration, or damage.
 - Refer to "CONNECTOR INSPECTION PROCEDURE" in BASIC INSPECTION PROCEDURE.

Are all connectors good?

Yes		No Repair or replace it.
------------	--	-----------------------------

2. CHECK REFERENCE VOLTAGE TO APS

1. Turn ignition switch to OFF and disconnect APS connector.
2. Turn ignition switch to ON.
3. Measure voltage in harness between terminal 6 of APS harness connector and chassis ground [APS 1].
4. Measure voltage in harness between terminal 2 of APS harness connector and chassis ground [APS 2].
 - Specification: approximately 5V

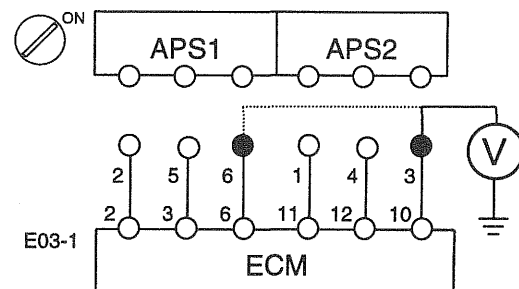

Is(Are) voltage(s) within specification?

Yes		No Repair open or short circuit in harness.
------------	--	--

3. CHECK FOR OPEN IN HARNESS

1. Turn ignition switch to OFF, and then disconnect ECM and APS connector.
2. Measure resistance between terminal 2 of APS harness connector and terminal E03-1(2) of ECM harness connector [APS 1].
3. Measure resistance between terminal 5 of APS harness connector and terminal E03-1(3) of ECM harness connector [APS 1].
4. Measure resistance between terminal 1 of APS harness connector and terminal E03-1(11) of ECM harness connector [APS 2].
5. Measure resistance between terminal 4 of APS harness connector and terminal E03-1(12) of ECM harness connector [APS 2].
 - Specification: below 1Ω

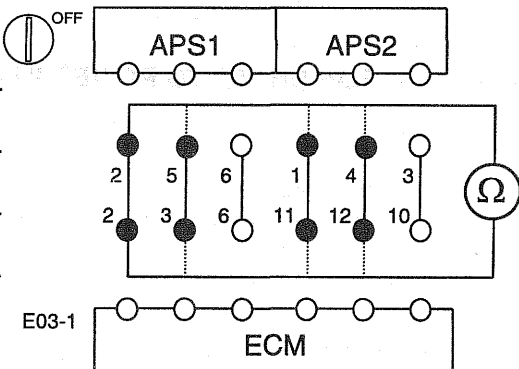

Is(Are) resistance(s) within specification?

Yes		No Repair open circuit in harness.
------------	--	---------------------------------------

4. CHECK FOR SHORT TO GROUND IN HARNESS

1. Turn ignition switch to OFF, and then disconnect ECM and APS connector.
 2. Measure resistance between terminal 2 of APS harness connector and chassis ground [APS 1].
 3. Measure resistance between terminal 2 and 5 of APS harness connector [APS 1].
 4. Measure resistance between terminal 1 of APS harness connector and chassis ground [APS 2].
 5. Measure resistance between terminal 1 and 4 of APS harness connector [APS 2].
- **Specification: infinite**

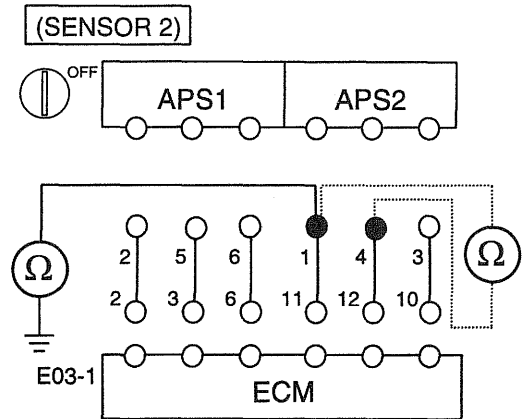
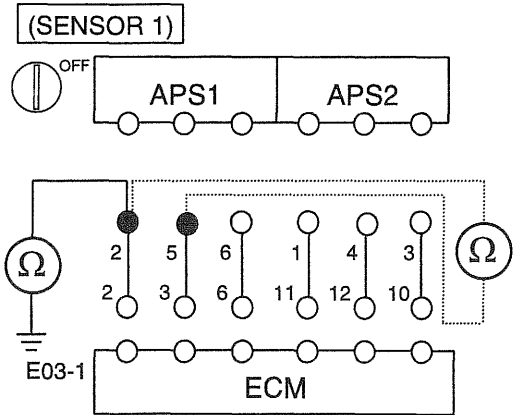

Is(Are) resistance(s) within specification?

Yes

No	Repair short or short to chassis ground in harness.
----	---

5. CHECK FOR SHORT TO POWER IN HARNESS

1. Turn ignition switch to OFF, and then disconnect ECM and APS connector.
 2. Turn ignition switch to ON.
 3. Measure voltage between terminal 2 of APS harness connector and chassis ground [APS 1].
 4. Measure voltage between terminal 1 of APS harness connector and chassis ground [APS 2].
- **Specification: below 0.5V**

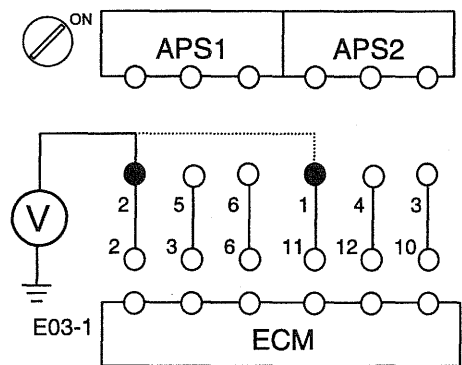

Is(Are) voltage(s) within specification?

Yes

No	Repair short to power in harness.
----	-----------------------------------

6. CHECK APS SIGNAL

1. Turn ignition switch to OFF and connect APS connector.
2. connect Hi-Scan (Pro) to APS.
3. Turn ignition switch to ON.
4. Using Hi-Scan (Pro), monitor APS signal while slowly stepping the accelerator position.
 - Refer to "SPECIFICATION" for more information.

Is signal within specification and consistent with the normal curve?

Yes

No	Replace the APS.
----	------------------

Proceed with "ECM PROBLEM INSPECTION PROCEDURE" in BASIC INSPECTION PROCEDURE.

TROUBLESHOOTING FOR DTC ED8D1F3D

DTC	P0180	Fuel Temperature Sensor (FTS) Circuit Malfunction
CC-CODE	0b	Signal low (Open circuit or short circuit to battery line)
	02	Signal high (Short circuit to ground)

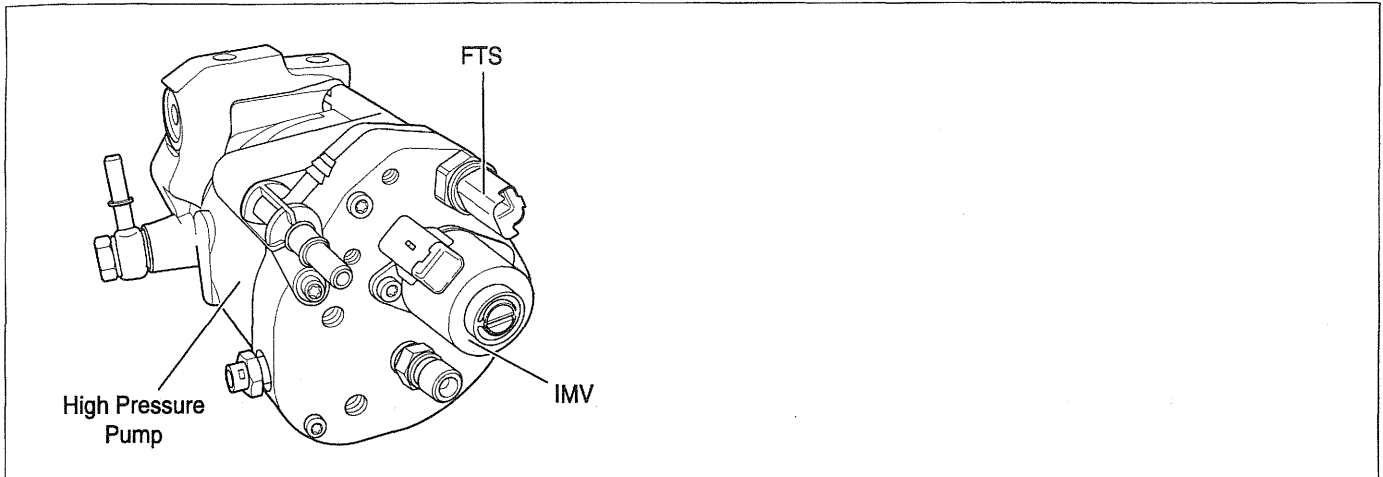

EWMF200Q

DESCRIPTION

The fuel temperature sensor (FTS) is located in the high-pressure pump assembly to measure the fuel temperature. The FTS uses a thermistor whose resistance changes with the temperature. The electrical resistance of the FTS decreases as the fuel temperature increases, and increases as the fuel temperature decreases. The 5 V power source in the ECM is supplied to the FTS via a resistor in the ECM.

That is, the resistor in the ECM and the thermistor in the FTS are connected in series. When the resistance value of the thermistor in FTS changes according to the fuel temperature, the signal voltage also changes. This information of fuel temperature is used in correcting fuel quantity.

DTC DETECTING CONDITION

CC-CODE	Detecting Condition	Suspect Area
0b	• Fuel temperature < -40°C(-40°F)	<ul style="list-style-type: none"> • Open or short in FTS circuit • FTS • ECM
02	• Fuel temperature > 140°C(284°F)	

SPECIFICATION

Temperature [°C (°F)]	-30(-22)	-20(-4)	0(32)	20(68)	40(104)	60(140)	80(176)
Resistance (kΩ)	22.2 ~ 31.8	13.2 ~ 18.1	5.2 ~ 6.6	2.3 ~ 2.7	1.1 ~ 1.3	0.54 ~ 0.65	0.30 ~ 0.32

[SCHEMATIC DIAGRAM]

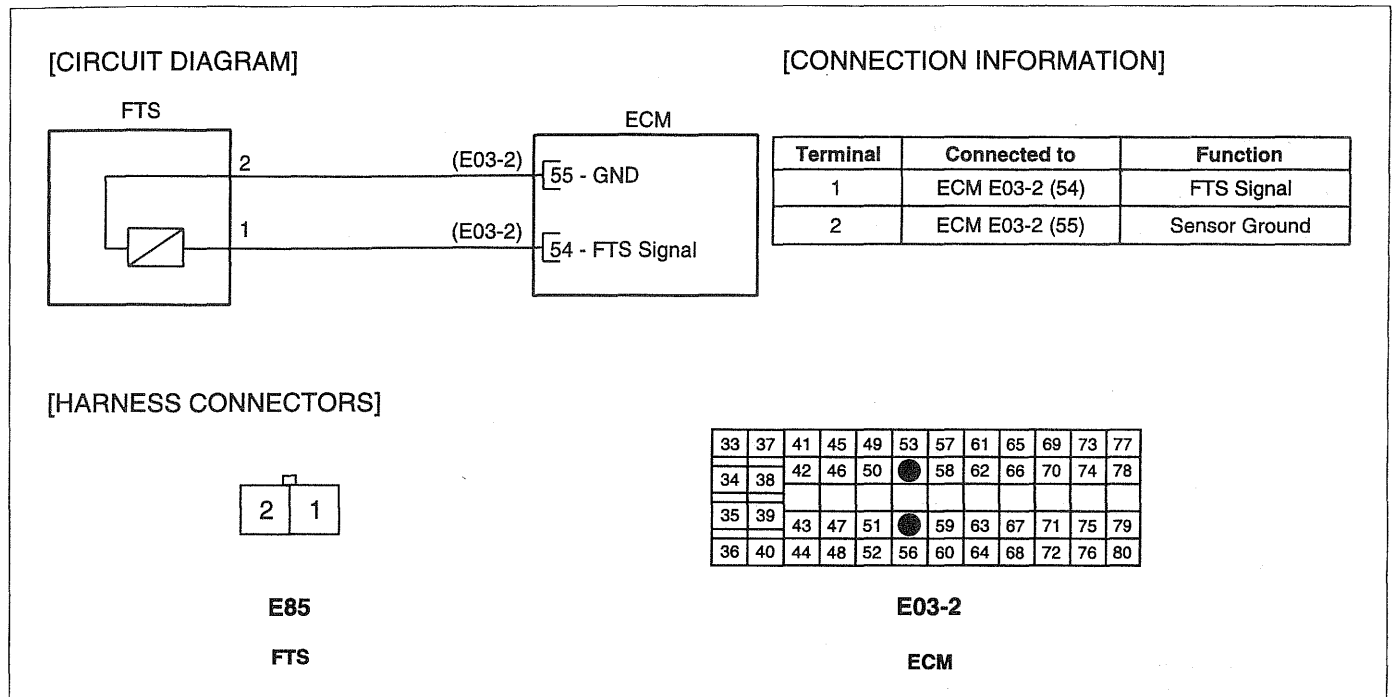

INSPECTION PROCEDURE

1. CHECK FTS AND ECM CONNECTORS

1. Thoroughly check connectors for looseness, poor connection, bending, corrosion, contamination, deterioration, or damage.
 - Refer to "CONNECTOR INSPECTION PROCEDURE" in BASIC INSPECTION PROCEDURE.

Are all connectors good?

Yes	No	Repair or replace it.
------------	----	-----------------------

2. CHECK REFERENCE VOLTAGE TO FTS

1. Turn ignition switch to OFF and disconnect FTS connector.
2. Turn ignition switch to ON.
3. Measure voltage in harness between terminal 1 of FTS harness connector and chassis ground.
 - **Specification: approximately 5V**

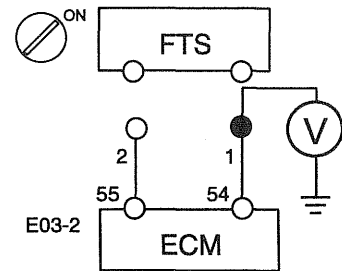

Is(Are) voltage(s) within specification?

Yes	No	Repair open or short circuit in harness.
------------	----	--

3. CHECK FOR OPEN IN HARNESS

1. Turn ignition switch to OFF, and then disconnect ECM and FTS connector.
2. Measure resistance between terminal 1 of FTS harness connector and terminal E03-2(54) of ECM harness connector.
3. Measure resistance between terminal 2 of FTS harness connector and terminal E03-2(55) of ECM harness connector.
 - **Specification: below 1Ω**

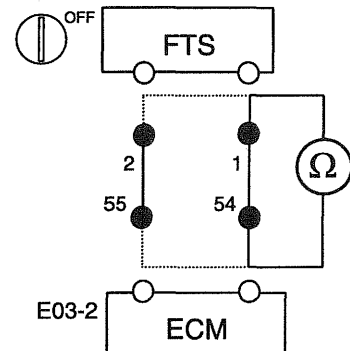

Is(Are) resistance(s) within specification?

Yes	No	Repair open circuit in harness.
------------	----	---------------------------------

4. CHECK FOR SHORT TO GROUND IN HARNESS

1. Turn ignition switch to OFF, and then disconnect ECM and FTS connector.
2. Measure resistance between terminal 1 of FTS harness connector and chassis ground.
3. Measure resistance between terminal 1 and 2 of FTS harness connector.
 - **Specification: infinite**

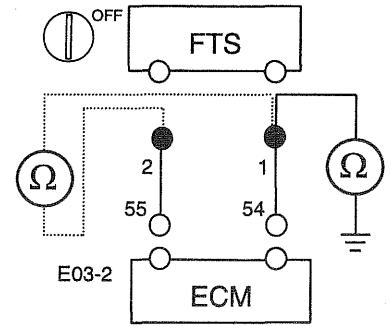

Is(Are) resistance(s) within specification?

Yes

No	Repair short or short to chassis ground in harness.
----	---

5. CHECK FOR SHORT TO POWER IN HARNESS

1. Turn ignition switch to OFF, and then disconnect ECM and FTS connector.
2. Turn ignition switch to ON.
3. Measure voltage between terminal 1 of FTS harness connector and chassis ground.
 - **Specification: below 0.5V**

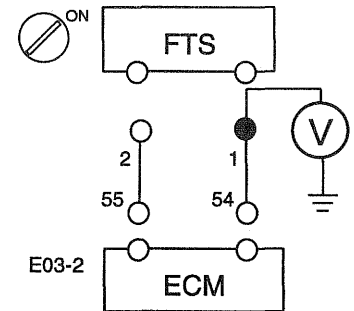

Is(Are) voltage(s) within specification?

Yes

No	Repair short to power in harness.
----	-----------------------------------

6. CHECK FTS RESISTANCE

1. Turn ignition switch to OFF and disconnect FTS connector.
2. Measure resistance between terminal 1 and 2 of FTS connector.
 - **Refer to "SPECIFICATION" for more information.**

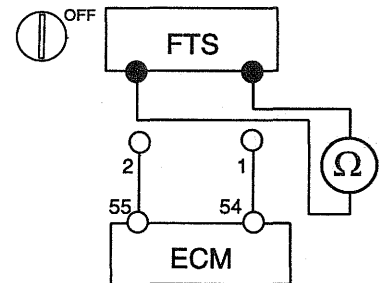

Is(Are) resistance(s) within specification?

Yes

No	Replace the FTS.
----	------------------

Proceed with "ECM PROBLEM INSPECTION PROCEDURE" in BASIC INSPECTION PROCEDURE.

TROUBLESHOOTING FOR DTC E6FE4E7A

DTC	P0190	Rail Pressure Sensor (RPS) Range/Performance Problem
CC-CODE	0a	Signal low (Short circuit to ground)
	0b	Signal high (Open circuit or short circuit to battery line)
	06	Rail pressure incoherent
	08	Signal low
	09	Signal high
	05	Parameter at maximum limit
	8d	Above the average threshold

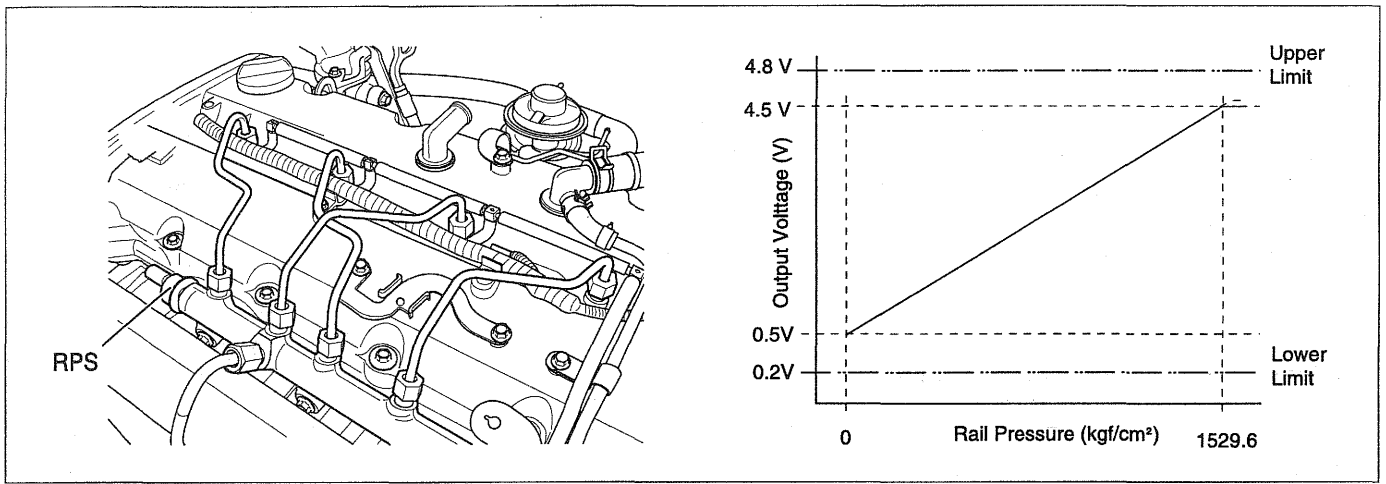

EWMF200R

DESCRIPTION

The aim of the Rail Pressure Sensor (RPS) is to provide to the ECM the voltage signal corresponding to fuel pressure in the rail. This information is used for fueling and timing calculation. The sensor element (semiconductor device) for converting the pressure to an electric signal is mounted on the diaphragm. The sensor operates as an

analog resistor. The change in resistance is proportional to the rail pressure acting upon this diaphragm. A rail pressure change lead to a geometry change. This movement changes the electrical resistance. A bridge circuit on the diaphragm supplies a voltage that is amplified to a range from 0.5 V to 4.5 V (respectively 0 and 1,800 kgf/cm²).

DTC DETECTING CONDITION

CC-CODE	Detecting Condition	Suspect Area
0a	• Rail pressure < -114.7 kgf/cm²	<ul style="list-style-type: none"> • Open or short in RPS circuit • RPS • ECM
0b	• Rail pressure > 1,950.2 kgf/cm²	
06	• Pressure variation greater than 255 kgf/cm² between two successive measurements.	
08	• Rail pressure < -91.8 kgf/cm² when IG ON	
09	• Rail pressure when IG ON is more than 255 kgf/cm² higher than the rail pressure at the previous IG OFF (upwards sensor drift).	
05	• Rail pressure > 1,753.9 kgf/cm²	
8d	• The rail pressure is > 91.8 kgf/cm² for 20 consecutive IG ON (upwards sensor drift).	

[SCHEMATIC DIAGRAM]

[CIRCUIT DIAGRAM]

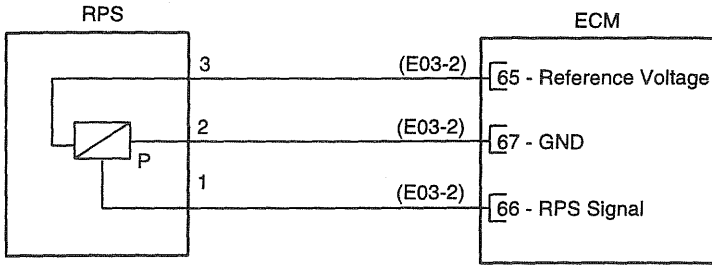

[CONNECTION INFORMATION]

Terminal	Connected to	Function
1	ECM E03-2 (66)	RPS Signal
2	ECM E03-2 (67)	Sensor Ground
3	ECM E03-2 (65)	Reference Voltage

[HARNESS CONNECTORS]

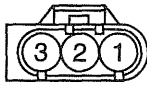

E88

RPS

33	37	41	45	49	53	57	61	65	69	73	77
34	38	42	46	50	54	58	62	66	70	74	78
35	39	43	47	51	55	59	63	67	71	75	79
36	40	44	48	52	56	60	64	68	72	76	80

E03-2

ECM

INSPECTION PROCEDURE

1. CHECK DTC

1. Connect the Hi-Scan (Pro) to the Data Link Connector (DLC).
2. Turn ignition switch to ON and check that any other DTC(s) is (are) detected.

Are the DTCs related to IMV (P1119 or P11200) also set?

Yes

No	Do all repairs associated with those codes before proceeding with this procedure.
----	---

2. CHECK RPS AND ECM CONNECTORS

1. Thoroughly check connectors for looseness, poor connection, bending, corrosion, contamination, deterioration, or damage.
 - Refer to "CONNECTOR INSPECTION PROCEDURE" in BASIC INSPECTION PROCEDURE.

Are all connectors good?

Yes

No	Repair or replace it.
----	-----------------------

3. CHECK REFERENCE VOLTAGE TO RPS

1. Turn ignition switch to OFF and disconnect RPS connector.
2. Turn ignition switch to ON.
3. Measure voltage in harness between terminal 3 of RPS harness connector and chassis ground.
 - Specification: approximately 5V

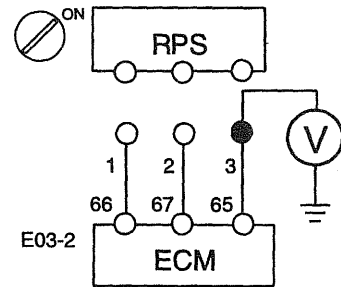

Is(Are) voltage(s) within specification?

Yes

No	Repair open or short circuit in harness.
----	--

4. CHECK FOR OPEN IN HARNESS

1. Turn ignition switch to OFF, and then disconnect ECM and RPS connector.
2. Measure resistance between terminal 1 of RPS harness connector and terminal E03-2(66) of ECM harness connector.
3. Measure resistance between terminal 2 of RPS harness connector and terminal E03-2(67) of ECM harness connector.
 - Specification: below 1Ω

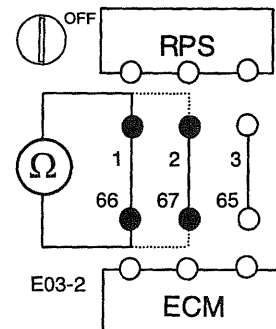

Is(Are) resistance(s) within specification?

Yes

No Repair open circuit in harness.

5. CHECK FOR SHORT TO GROUND IN HARNESS

1. Turn ignition switch to OFF, and then disconnect ECM and RPS connector.
2. Measure resistance between terminal 1 of RPS harness connector and chassis ground.
3. Measure resistance between terminal 1 and 2 of RPS harness connector.
 - **Specification: infinite**

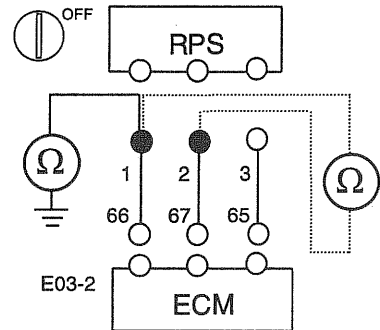

Is(Are) resistance(s) within specification?

Yes

No Repair short or short to chassis ground in harness.

6. CHECK FOR SHORT TO POWER IN HARNESS

1. Turn ignition switch to OFF, and then disconnect ECM and RPS connector.
2. Turn ignition switch to ON.
3. Measure voltage between terminal 1 of RPS harness connector and chassis ground.
 - **Specification: below 0.5V**

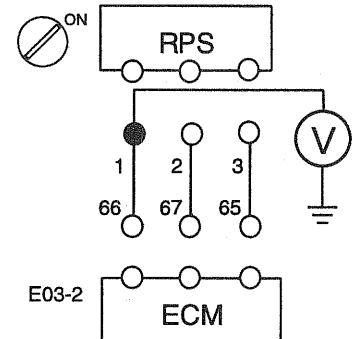

Is(Are) voltage(s) within specification?

Yes

No Repair short to power in harness.

7. CHECK RPS

1. Replace the RPS with a new one, and then monitor the vehicle again using a Hi-Scan (Pro).

Is this problem fixed?

Yes

No Replace the RPS.

Proceed with "ECM PROBLEM INSPECTION PROCEDURE" in BASIC INSPECTION PROCEDURE.

TROUBLESHOOTING FOR DTC E35C1F2A

DTC	P0201	Inector #1 (Cylinder #1) Circuit Malfunction
DTC	P0202	Inector #2 (Cylinder #3) Circuit Malfunction
DTC	P0203	Inector #3 (Cylinder #4) Circuit Malfunction
DTC	P0204	Inector #4 (Cylinder #2) Circuit Malfunction
CC-CODE	04	Signal low
	91	Injector stuck (Open)
	86	Injector stuck (Close)
	01	Open Circuit
	0c	Short Circuit

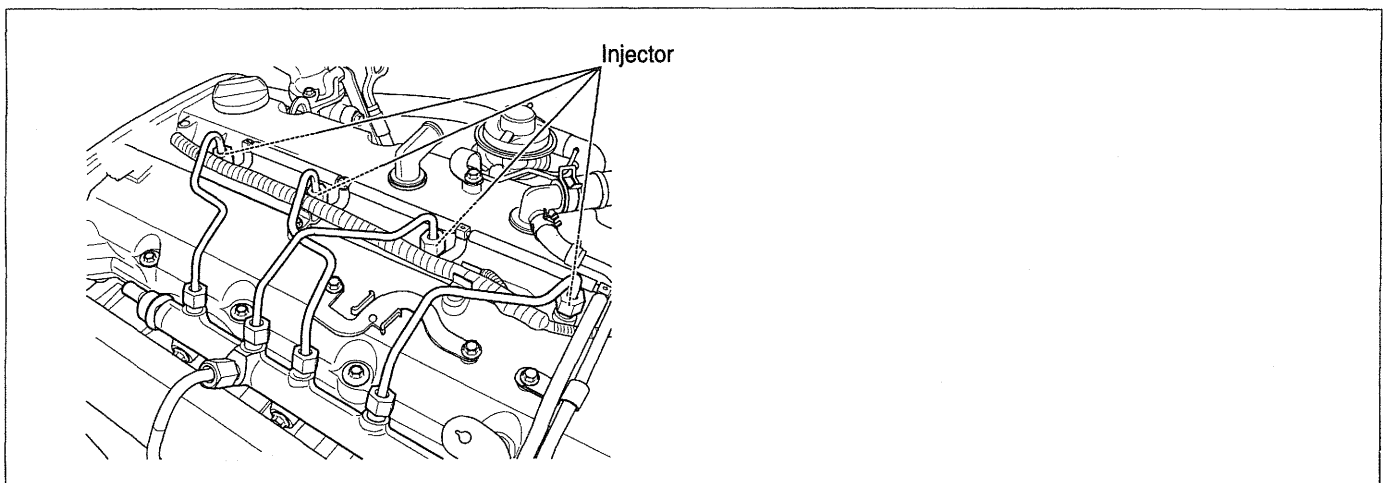

EWMF202M

DESCRIPTION

The injector of the Common Rail System is electronically controlled. It has been designed to allow multiple injection with short intervals, to be fully electronically controlled, and to release a small amount of heat. The nozzle of injector opens when the solenoid valve is triggered and permits the flow of fuel. They inject the fuel directly into the engine's combustion chamber. The fuel is stored in the Rail ready for injection and the injected fuel quantity is defined by the injector opening time and the rail pressure.

The excess fuel, which was needed for opening the nozzle of injector, flows back to the tank through a collector line. The return fuel from the pressure-control valve and from the low-pressure stage is also led into this collector line together with the fuel used to lubricate the high-pressure pump.

DTC DETECTING CONDITION

CC-CODE	Detecting Condition	Suspect Area
04	<ul style="list-style-type: none"> MDP (Minimum Drive Pulse) correction determined by the knock sensor strategy exceeds a calibrated value. 	<ul style="list-style-type: none"> Open or short circuit in injector Injector Compression pressure Fuel line ECM
91	<ul style="list-style-type: none"> Injector stuck (Open) 	
86	<ul style="list-style-type: none"> Injector stuck (Close) 	
01	<ul style="list-style-type: none"> Open circuit 	
0c	<ul style="list-style-type: none"> Short circuit 	

[SCHEMATIC DIAGRAM]

[CIRCUIT DIAGRAM]

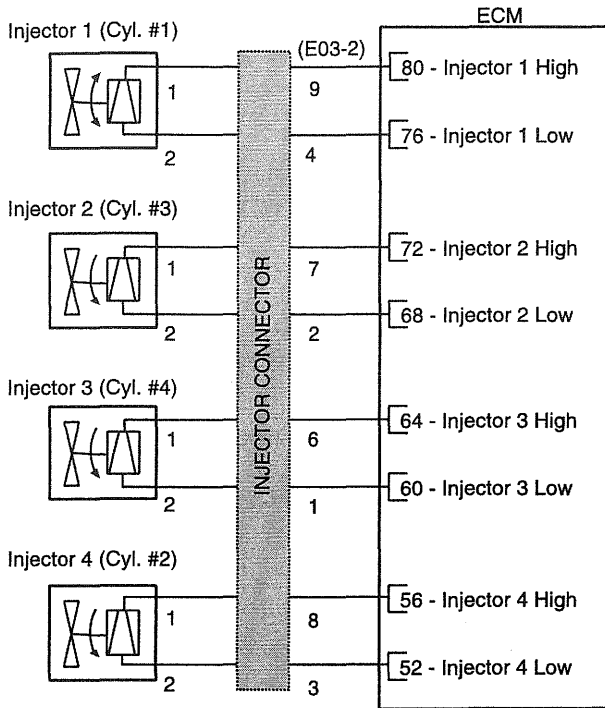

[CONNECTION INFORMATION]

Injector #1 (Cylinder #1)

Terminal	Injector Connector	Connected to	Function
1	7	ECM E03-2 (80)	Injector1 (Cyl. #1) High
2	2	ECM E03-2 (76)	Injector1 (Cyl. #1) Low

Injector #2 (Cylinder #3)

Terminal	Injector Connector	Connected to	Function
1	9	ECM E03-2 (72)	Injector2 (Cyl. #3) High
2	4	ECM E03-2 (68)	Injector2 (Cyl. #3) Low

Injector #3 (Cylinder #4)

Terminal	Injector Connector	Connected to	Function
1	10	ECM E03-2 (64)	Injector3 (Cyl. #4) High
2	5	ECM E03-2 (60)	Injector3 (Cyl. #4) Low

Injector #4 (Cylinder #2)

Terminal	Injector Connector	Connected to	Function
1	8	ECM E03-2 (56)	Injector4 (Cyl. #2) High
2	3	ECM E03-2 (52)	Injector4 (Cyl. #2) Low

[HARNES CONNECTORS]

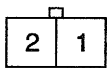

E157
INJECTOR

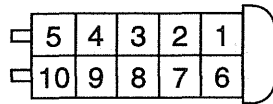

INJECTOR CONNECTOR

33	37	41	45	49	53	57	61	65	69	73	77
34	38	42	46	50	54	58	62	66	70	74	78
35	39	43	47	51	55	59	63	67	71	75	79
36	40	44	48	●	●	●	●	●	●	●	●

E03-2
ECM

INSPECTION PROCEDURE

1. CHECK DTC

1. Connect the Hi-Scan (Pro) to the Data Link Connector (DLC).
2. Turn ignition switch to ON and check that any other DTC(s) is (are) detected.

Are the CC-codes 86, 91, or 04 also set?

Yes

No	<ul style="list-style-type: none"> • CC-CODE 86 or 91 <ul style="list-style-type: none"> - Inspect the cylinder compression pressure (refer to group "EM" in this Shop Manual) - Inspect the fuel delivery line (refer to "FUEL DELIVERY SYSTEM-DIESEL") • CC-CODE 04 <ul style="list-style-type: none"> - Replace the injector
----	--

2. CHECK INJECTOR AND ECM CONNECTORS

1. Thoroughly check connectors for looseness, poor connection, bending, corrosion, contamination, deterioration, or damage.
 - Refer to "CONNECTOR INSPECTION PROCEDURE" in BASIC INSPECTION PROCEDURE.

Are all connectors good?

Yes

No	Repair or replace it.
----	-----------------------

3. CHECK FOR OPEN IN HARNESS

1. Turn ignition switch to OFF and wait for about 10 seconds.
2. Disconnect ECM and injector connector.
3. Measure resistance between terminal 1 of injector harness connector and terminal E03-2(80/72/64/56) of ECM harness connector (respectively injector #1/2/3/4).
4. Measure resistance between terminal 2 of injector harness connector and terminal E03-2(76/68/60/52) of ECM harness connector (respectively injector #1/2/3/4).
 - Specification: below 1Ω

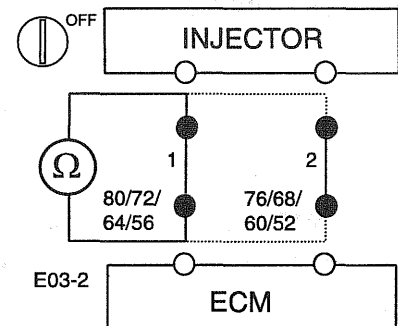

Is(Are) resistance(s) within specification?

Yes

No	Repair open circuit in harness.
----	---------------------------------

4. CHECK FOR SHORT IN HARNESS

1. Turn ignition switch to OFF and wait for about 10 seconds.
2. Disconnect ECM and injector connector.
3. Measure resistance between terminal 1 and 2 of injector harness connector.
 - **Specification: infinite**

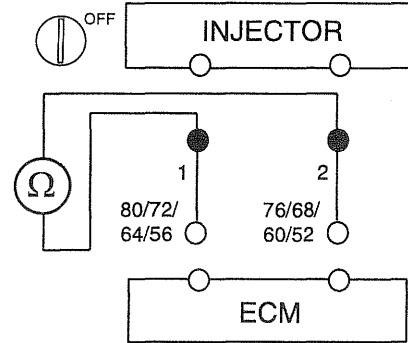

Is(Are) resistance(s) within specification?

Yes

No	Repair short or short to chassis ground in harness.
----	---

5. CHECK INJECTOR

1. Turn ignition switch to OFF and wait for about 10 seconds.
2. Disconnect injector connector.
3. Measure resistance between terminal 1 and 2 of injector connector.
 - **Specification: below 1Ω**

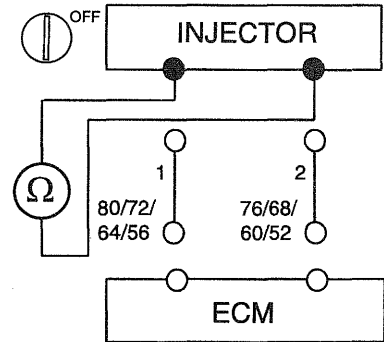

Is(Are) resistance(s) within specification?

Yes

No	Replace the injector.
----	-----------------------

Proceed with "ECM PROBLEM INSPECTION PROCEDURE" in BASIC INSPECTION PROCEDURE.

TROUBLESHOOTING FOR DTC E133D74F

DTC	P0226	Accelerator Position Sensor (APS) 2 Range/Performance Problem
CC-CODE	06	APS 1/2 signal incoherent
	0b	Abnormal signal

DTC DETECTING CONDITION

CC-CODE	Detecting Condition	Suspect Area
06	<ul style="list-style-type: none"> • APS 1/2 circuit malfunction 	<ul style="list-style-type: none"> • Refer to P0120, P0220
0b	<ul style="list-style-type: none"> • Accelerator pedal fault • Brake switch circuit malfunction 	<ul style="list-style-type: none"> • Accelerator pedal • Open or short in brake switch circuit • Brake switch • ECM

INSPECTION PROCEDURE

- CC-CODE 06: Refer to troubleshooting procedure for DTC P0120, P0220
- CC-CODE 06
 - Inspect accelerator pedal
 - Inspect brake switch circuit (Refer to troubleshooting procedure for DTC P1543)

TROUBLESHOOTING FOR DTC EA19DE6F

DTC	P0325	Knock Sensor Circuit Malfunction
CC-CODE	09	Signal High
	07	No Signal

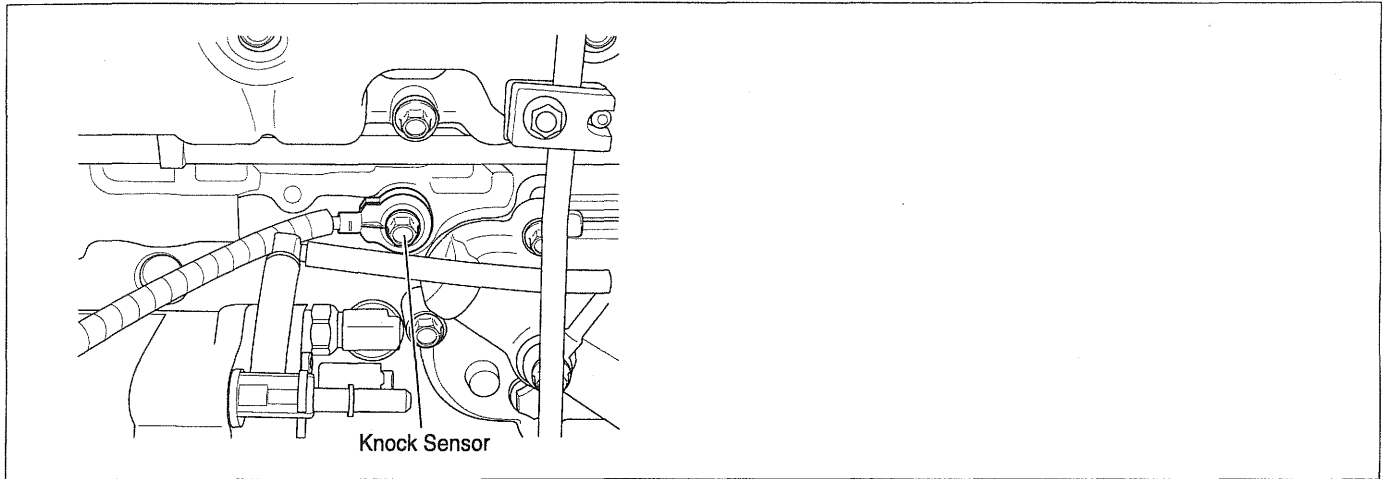

EWMF200V

DESCRIPTION

A knock sensor with piezoelectric element (ceramic) is attached to the center of cylinder block to sense the engine knocking condition (Check for knocking for each cylinder). The piezoelectric device output (V) = Q/C = 2dF/C (d = piezoelectric integer, C = Electrostatic capacity). The ECM

performs the knocking control to make the engine to operate in optimum condition before the knocking limit.

DTC DETECTING CONDITION

CC-CODE	Detecting Condition	Suspect Area
09	<ul style="list-style-type: none"> Abnormal signal 	<ul style="list-style-type: none"> Open or short in Knock Sensor circuit Knock Sensor ECM
07		

[SCHEMATIC DIAGRAM]

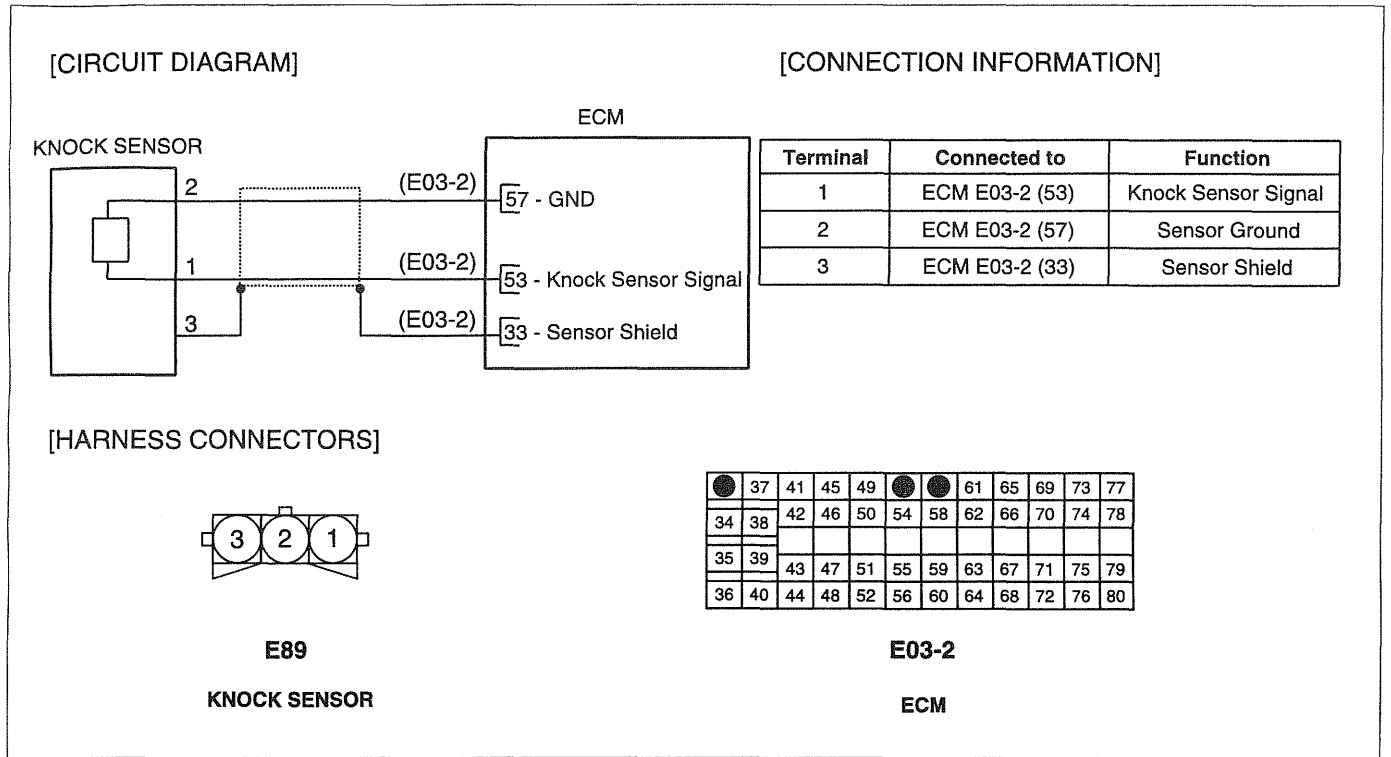

INSPECTION PROCEDURE

1. CHECK DTC

1. Connect the Hi-Scan (Pro) to the Data Link Connector (DLC).
2. Turn ignition switch to ON and check that any other DTC(s) is (are) detected.

Are the DTC related to ECTS, MAFS, IATS, or Atmospheric Pressure Sensor also set?

Yes

No

Do all repairs associated with those codes before proceeding with this procedure

2. CHECK KNOCK SENSOR AND ECM CONNECTORS

1. Thoroughly check connectors for looseness, poor connection, bending, corrosion, contamination, deterioration, or damage.
 - Refer to "CONNECTOR INSPECTION PROCEDURE" in BASIC INSPECTION PROCEDURE.

Are all connectors good?

Yes

No

Repair or replace it.

3. CHECK REFERENCE VOLTAGE TO KNOCK SENSOR

1. Turn ignition switch to OFF and disconnect knock sensor connector.
2. Turn ignition switch to ON.
3. Measure voltage in harness between terminal 1 of knock sensor harness connector and chassis ground.
 - Specification: approximately 5V

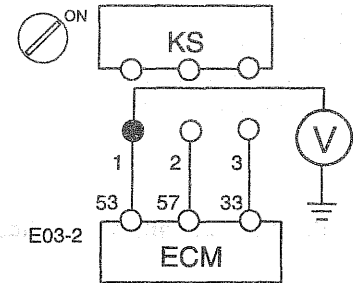

Is(Are) voltage(s) within specification?

Yes

No

Repair open or short circuit in harness.

4. CHECK FOR OPEN IN HARNESS

1. Turn ignition switch to OFF, and then disconnect ECM and knock sensor connector.
2. Measure resistance between terminal 1 of knock sensor harness connector and terminal E03-2(53) of ECM harness connector.
3. Measure resistance between terminal 2 of knock sensor harness connector and terminal E03-2(57) of ECM harness connector.
4. Measure resistance between terminal 3 of knock sensor harness connector and terminal E03-2(33) of ECM harness connector.
 - Specification: below 1Ω

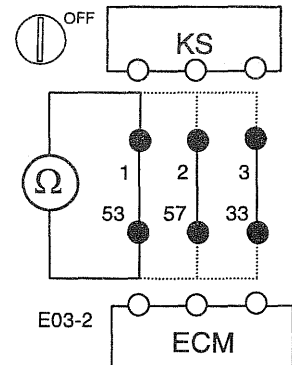

Is(Are) resistance(s) within specification?

Yes

No Repair open circuit in harness.

5. CHECK FOR SHORT TO GROUND IN HARNESS

1. Turn ignition switch to OFF, and then disconnect ECM and knock sensor connector.
2. Measure resistance between terminal 1 of knock sensor harness connector and chassis ground.
3. Measure resistance between terminal 1 and 2 of knock sensor harness connector.
 - **Specification: infinite**

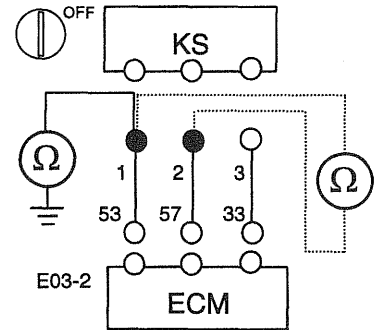

Is(Are) resistance(s) within specification?

Yes

No Repair short or short to chassis ground in harness.

6. CHECK FOR SHORT TO POWER IN HARNESS

1. Turn ignition switch to OFF, and then disconnect ECM and knock sensor connector.
2. Turn ignition switch to ON.
3. Measure voltage between terminal 1 of knock sensor harness connector and chassis ground.
 - **Specification: below 0.5V**

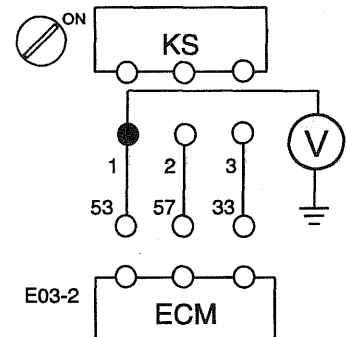

Is(Are) voltage(s) within specification?

Yes

No Repair short to power in harness.

7. CHECK KNOCK SENSOR

1. Replace the knock sensor with a new one, and then monitor the vehicle again using a Hi-Scan (Pro).

Is this problem fixed?

Yes

No Replace the knock sensor.

Proceed with "ECM PROBLEM INSPECTION PROCEDURE" in BASIC INSPECTION PROCEDURE.

TROUBLESHOOTING FOR DTC E73A1AE4

DTC	P0335	Crankshaft Position Sensor (CKPS) Circuit Malfunction
CC-CODE	06	Abnormal airgap
	07	No signal
	92	Too many missing teeth detected
	93	Too many extra teeth detected
	94	Missing teeth detected
	95	Extra teeth detected

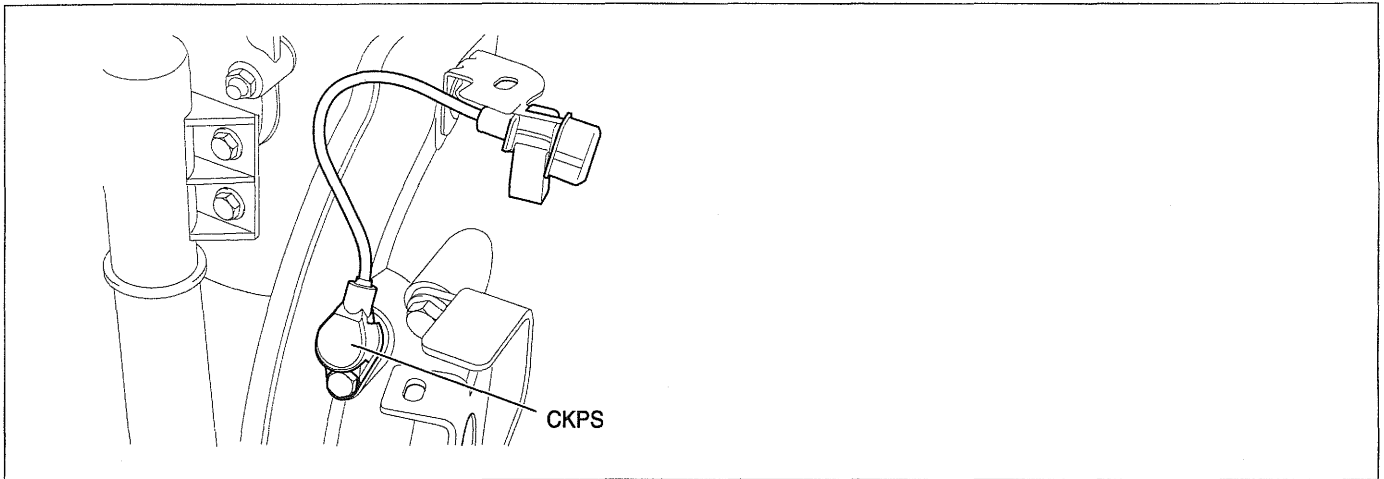

AFBE200Z

DESCRIPTION

Piston position on combustion chamber is the substantial to define the starting of injection timing. All engine pistons are connected to crankshaft by connecting rod. Crankshaft position sensor (CKPS) senses the information concerning all piston positions and uses this signal to calculate the injection timing and engine speed. Camshaft position sensor (CMPS) senses the position of camshaft in reference to the upper dead point of compression of cylinder and sends this signal, based on which the ECM determines the injection sequence of each cylinder and the fuel injection timing.

DTC DETECTING CONDITION

CC-CODE	Detecting Condition	Suspect Area
06	• No gap detection on the engine flywheel, but no extra or mission teeth detected	<ul style="list-style-type: none"> • Open or short in CKPS • CKPS • ECM
07	• Loss of engine speed sensor signal	
92	• More than 4 missing teeth detected on an engine flywheel rotation	
93	• More than 2 extra teeth detected on an engine flywheel rotation	
94	• 4 missing teeth detected on an engine flywheel rotation	
95	• 2 extra teeth detected on an engine flywheel rotation	

SPECIFICATION

Air gab between target wheel and CKPS	0.5 ~ 1.5 mm
---------------------------------------	--------------

[SCHEMATIC DIAGRAM]

[CIRCUIT DIAGRAM]

[CONNECTION INFORMATION]

Terminal	Connected to	Function
1	ECM E03-2 (58)	CKPS [+] Signal
2	ECM E03-2 (59)	CKPS [-] Signal
3	ECM E03-2 (37)	Sensor Shield

[HARNESS CONNECTORS]

C04
CKPS

33	41	45	49	53	57	61	65	69	73	77
34	38	42	46	50	54	62	66	70	74	78
35	39	43	47	51	55	63	67	71	75	79
36	40	44	48	52	56	60	64	68	72	80

E03-2
ECM

INSPECTION PROCEDURE

1. CHECK CKPS AND ECM CONNECTORS

1. Thoroughly check connectors for looseness, poor connection, bending, corrosion, contamination, deterioration, or damage.
 - Refer to "CONNECTOR INSPECTION PROCEDURE" in BASIC INSPECTION PROCEDURE.

Are all connectors good?

Yes		
No		Repair or replace it.

2. CHECK FOR OPEN IN HARNESS

1. Turn ignition switch to OFF, and then disconnect ECM and CKPS connector.
2. Measure resistance between terminal 1 of CKPS harness connector and terminal E03-2(58) of ECM harness connector.
3. Measure resistance between terminal 2 of CKPS harness connector and terminal E03-2(59) of ECM harness connector.
 - Specification: below 1Ω

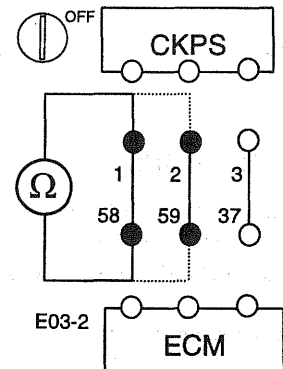

Is(Are) resistance(s) within specification?

Yes		
No		Repair open circuit in harness.

3. CHECK FOR SHORT TO GROUND IN HARNESS

1. Turn ignition switch to OFF, and then disconnect ECM and CKPS connector.
2. Measure resistance between terminal 1 of CKPS harness connector and chassis ground.
3. Measure resistance between terminal 2 of CKPS harness connector and chassis ground.
 - Specification: infinite

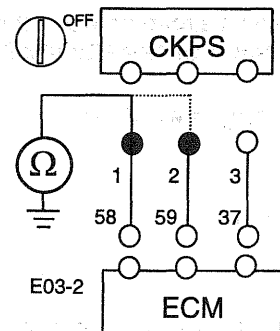

Is(Are) resistance(s) within specification?

Yes		
No		Repair short or short to chassis ground in harness.

4. CHECK FOR SHORT TO POWER IN HARNESS

1. Turn ignition switch to OFF, and then disconnect ECM and CKPS connector.
2. Turn ignition switch to ON.
3. Measure voltage between terminal 1 of CKPS harness connector and chassis ground.
4. Measure voltage between terminal 2 of CKPS harness connector and chassis ground.
 - **Specification: below 0.5V**

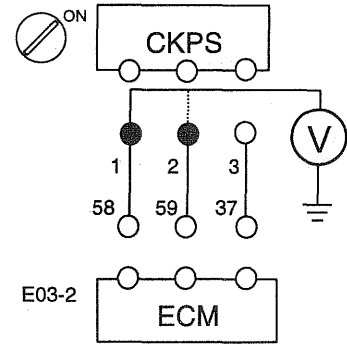

Is(Are) voltage(s) within specification?

Yes	No	Repair short to power in harness.
------------	----	-----------------------------------

5. CHECK CKPS

1. Replace the CKPS with a new one, and then monitor the vehicle again using a Hi-Scan (Pro).
 - **Specification: below 0.5V**

Is this problem fixed?

Yes	No	Replace the knock sensor.
------------	----	---------------------------

6. CHECK CKPS AIRGAP

1. Inspect airgap between the target-wheel and CKPS.
 - **Refer to "SPECIFICATION" for more information.**

Is the airgap within specification?

Yes	No	Adjust airgap between target-wheel and CKPS.
------------	----	--

Proceed with "ECM PROBLEM INSPECTION PROCEDURE" in BASIC INSPECTION PROCEDURE.

TROUBLESHOOTING FOR DTC E37B3222

DTC	P0340	Camshaft Position Sensor (CMPS) Circuit Malfunction
CC-CODE	07	No signal
	06	CMPS/CKPS signal incoherent

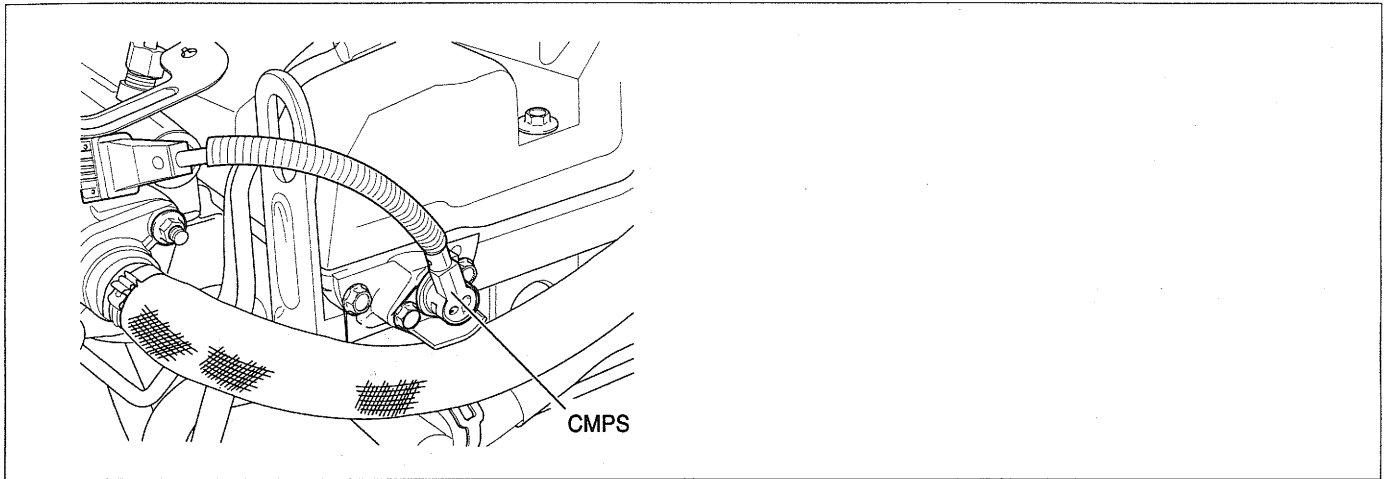

AFBE204D

DESCRIPTION

Piston position on combustion chamber is the substantial to define the starting of injection timing. All engine pistons are connected to crankshaft by connecting rod. Crankshaft position sensor (CKPS) senses the information concerning all piston positions and uses this signal to calculate the injection timing and engine speed. Camshaft position sensor (CMPS) senses the position of camshaft in

reference to the upper dead point of compression of cylinder and sends this signal, based on which the ECM determines the injection sequence of each cylinder and the fuel injection timing.

DTC DETECTING CONDITION

CC-CODE	Detecting Condition	Suspect Area
07	<ul style="list-style-type: none"> No signal 	<ul style="list-style-type: none"> Open or short in CMPS circuit CMPS ECM
06	<ul style="list-style-type: none"> CMPS/CKPS incoherent 	

[SCHEMATIC DIAGRAM]

[CIRCUIT DIAGRAM]

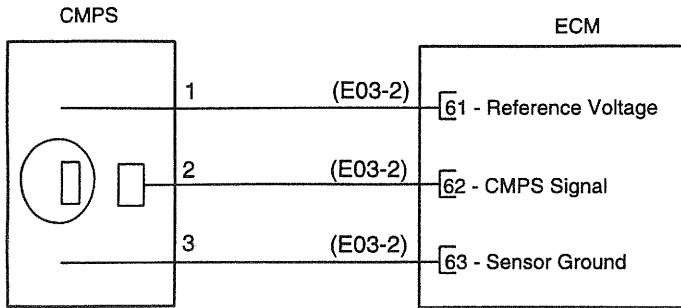

[CONNECTION INFORMATION]

Terminal	Connected to	Function
1	ECM E03-2 (61)	Reference Voltage
2	ECM E03-2 (62)	CMPS Signal
3	ECM E03-2 (63)	Sensor Ground

[HARNESS CONNECTORS]

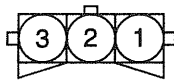

E90
CMPS

33	37	41	45	49	53	57	65	69	73	77	
34	38	42	46	50	54	58	66	70	74	78	
35	39	43	47	51	55	59	67	71	75	79	
36	40	44	48	52	56	60	64	68	72	76	80

E03-2
ECM

INSPECTION PROCEDURE

1. CHECK CMPS AND ECM CONNECTORS

1. Thoroughly check connectors for looseness, poor connection, bending, corrosion, contamination, deterioration, or damage.
 - Refer to "CONNECTOR INSPECTION PROCEDURE" in BASIC INSPECTION PROCEDURE.

Are all connectors good?

Yes		No	Repair or replace it.
-----	--	----	-----------------------

2. CHECK REFERENCE VOLTAGE TO CMPS

1. Turn ignition switch to OFF and disconnect CMPS connector.
2. Turn ignition switch to ON.
3. Measure voltage in harness between terminal 1 of CMPS harness connector and chassis ground.
 - Specification: approximately 5V

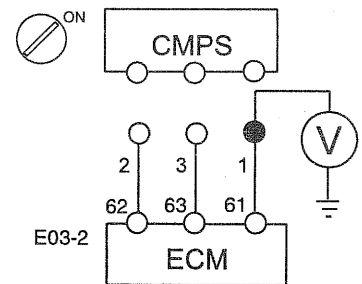

Is(Are) voltage(s) within specification?

Yes		No	Repair open or short circuit in harness.
-----	--	----	--

3. CHECK FOR OPEN IN HARNESS

1. Turn ignition switch to OFF, and then disconnect ECM and CMPS connector.
2. Measure resistance between terminal 2 of CMPS harness connector and terminal E03-2(62) of ECM harness connector.
3. Measure resistance between terminal 3 of CMPS harness connector and terminal E03-2(63) of ECM harness connector.
 - Specification: below 1Ω

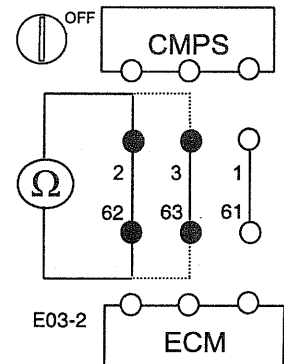

Is(Are) resistance(s) within specification?

Yes		No	Repair open circuit in harness.
-----	--	----	---------------------------------

4. CHECK FOR SHORT TO GROUND IN HARNESS

1. Turn ignition switch to OFF, and then disconnect ECM and CMPS connector.
2. Measure resistance between terminal 2 of CMPS harness connector and chassis ground.
3. Measure resistance between terminal 2 and 3 of CMPS harness connector.
 - **Specification: infinite**

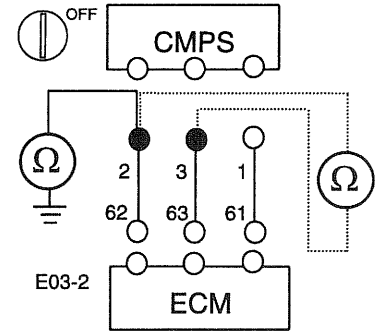

Is(Are) resistance(s) within specification?

Yes

No	Repair short or short to chassis ground in harness.
----	---

5. CHECK FOR SHORT TO POWER IN HARNESS

1. Turn ignition switch to OFF, and then disconnect ECM and CMPS connector.
2. Turn ignition switch to ON.
3. Measure voltage between terminal 2 of CMPS harness connector and chassis ground.
 - **Specification: below 0.5V**

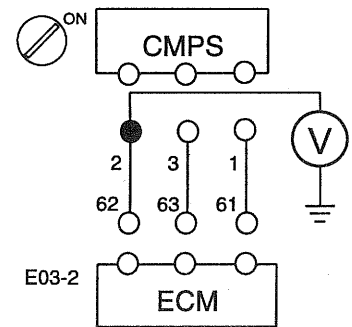

Is(Are) voltage(s) within specification?

Yes

No	Repair short to power in harness.
----	-----------------------------------

6. CHECK TIMING BELT

1. Inspect the timing belt installation condition (Refer to the group "EM" in this Shop Manual).

Is the timing belt installed correctly?

Yes

No	Adjust or replace the timing belt.
----	------------------------------------

7. CHECK CKPS

1. Replace the CKPS with a new one, and then monitor the vehicle again using a Hi-Scan (Pro).

Is this problem fixed?

No

Yes	Replace the CMPS.
-----	-------------------

Proceed with "ECM PROBLEM INSPECTION PROCEDURE" in BASIC INSPECTION PROCEDURE.

TROUBLESHOOTING FOR DTC E0430229

DTC	P0380	Glow Relay 1 Circuit Malfunction
CC-CODE	0a	Signal low (Open circuit or short circuit to ground)
	03	Signal high (Short circuit to battery line)
	0a	Open circuit or short circuit to ground
	03	Short circuit to battery line

DTC	P0382	Glow Relay 2 Circuit Malfunction
CC-CODE	0a	Signal low (Open circuit or short circuit to ground)
	03	Signal high (Short circuit to battery line)
	0a	Open circuit or short circuit to ground
	03	Short circuit to battery line

DESCRIPTION

Glow plug plays an efficient role at cold start. It also shortens the warm-up period, a fact that is highly relevant for exhaust emissions. The time of preheating is determined by a number of parameters that include the engine speed

and the coolant temperature. The ECM controls the glow plug via glow plug relay.

DTC DETECTING CONDITION

CC-CODE	Detecting Condition	Suspect Area
0a	<ul style="list-style-type: none"> • Open or short to ground in glow relay circuit 	<ul style="list-style-type: none"> • Open or short in Glow Relay circuit • Glow Relay • ECM
03	<ul style="list-style-type: none"> • Short to battery line in glow relay circuit 	

[SCHEMATIC DIAGRAM]

[CIRCUIT DIAGRAM]

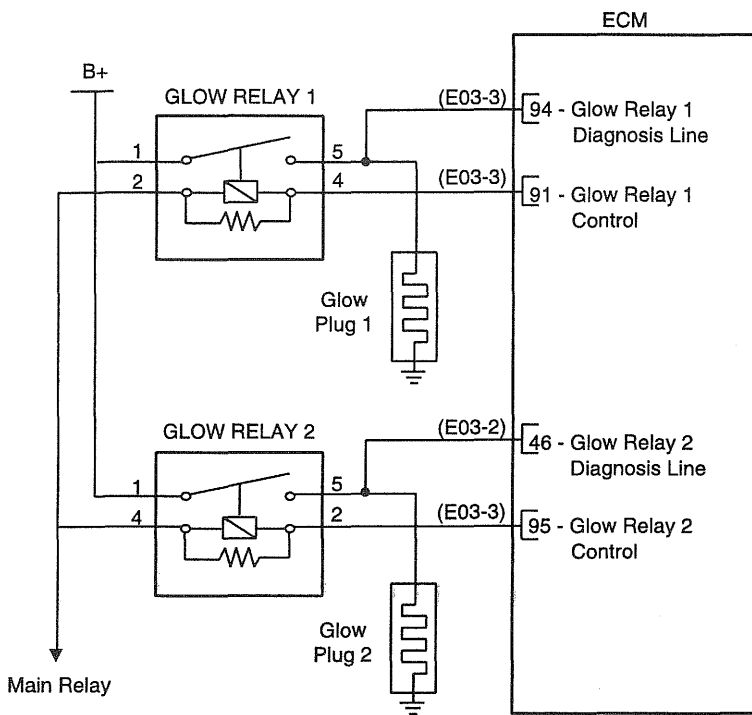

[CONNECTION INFORMATION]

Glow Relay 1

Terminal	Connected to	Function
1	Battery	Battery Voltage
2	Main Relay	Battery Voltage
3	-	-
4	ECM E03-3 (91)	Diagnosis
5	ECM E03-3 (94)	Glow Relay 1 Control
	Glow Plug 1	Glow Plug 1 Control

Glow Relay 2

Terminal	Connected to	Function
1	Battery	Battery Voltage
2	ECM E03-2 (95)	Diagnosis
3	-	-
4	Main Relay	Battery Voltage
5	ECM E03-2 (46)	Glow Relay 2 Control
	Glow Plug 2	Glow Plug 2 Control

[HARNESS CONNECTORS]

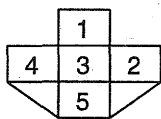

E140

Glow Relay 1

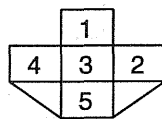

E52

Glow Relay 2

33	37	41	45	49	53	57	61	65	69	73	77
34	38	42	46	50	54	58	62	66	70	74	78
35	39	43	47	51	55	59	63	67	71	75	79
36	40	44	48	52	56	60	64	68	72	76	80

E03-2

ECM

81	85	89	93	97	101	105	109
82	86	90	94	98	102	106	110
83	87	91	95	99	103	107	111
84	88	92	96	100	104	108	112

E03-3

INSPECTION PROCEDURE

1. CHECK GLOW RELAY AND ECM CONNECTORS

1. Thoroughly check connectors for looseness, poor connection, bending, corrosion, contamination, deterioration, or damage.
 - Refer to "CONNECTOR INSPECTION PROCEDURE" in BASIC INSPECTION PROCEDURE.

Are all connectors good?

Yes	No	Repair or replace it.
-----	----	-----------------------

2. CHECK GLOW RELAY

1. Turn ignition switch to OFF and remove the glow relay.
2. Apply power to the terminal 2(4) and ground terminal 4(2) of glow relay 1(2).
3. Check if glow relay works well. (If glow relay works normally, a "click" sound can be heard).

Does the glow relay operate normally?

Yes	No	Replace the glow plug relay
-----	----	-----------------------------

3. CHECK REFERENCE VOLTAGE TO GLOW RELAY

1. Turn ignition switch to OFF and disconnect glow relay connector.
2. Turn ignition switch to ON.
3. Measure voltage in harness between terminal 1 of glow relay harness connector and chassis ground.
4. Measure voltage in harness between terminal 2(4) of glow relay harness connector and chassis ground.
 - **Specification: approximately B+**

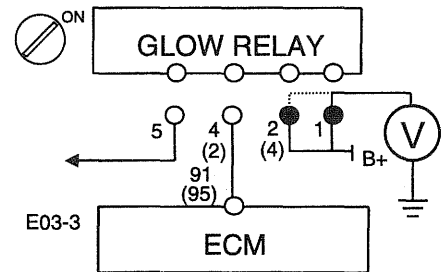

(): Glow Relay #2

Is(Are) voltage(s) within specification?

Yes	No	Repair open or short circuit in harness.
-----	----	--

4. CHECK FOR OPEN IN HARNESS

1. Turn ignition switch to OFF, and then disconnect ECM and glow relay connector.
2. Measure resistance between terminal 4(2) of glow relay 1(2)harness connector and terminal E03-3(91)(E03-3(95)) of ECM harness connector.
 - **Specification: below 1Ω**

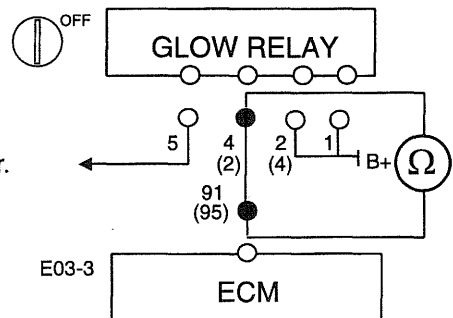

(): Glow Relay #2

Is(Are) resistance(s) within specification?

Yes		No Repair open circuit in harness.
------------	--	------------------------------------

5. CHECK FOR SHORT TO GROUND IN HARNESS

1. Turn ignition switch to OFF, and then disconnect ECM and glow relay connector.
2. Measure resistance between terminal 4(2) of glow relay 1(2) harness connector and chassis ground.
3. Measure resistance between terminal 2 and 3 of glow relay harness connector.
 - **Specification: infinite**

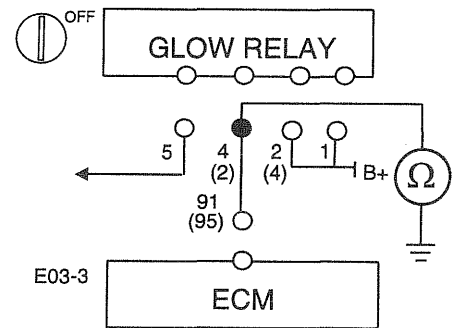

Is(Are) resistance(s) within specification?

(): Glow Relay #2

Yes		No Repair short or short to chassis ground in harness.
------------	--	--

6. CHECK FOR SHORT TO POWER IN HARNESS

1. Turn ignition switch to OFF, and then disconnect ECM and glow relay connector.
2. Turn ignition switch to ON.
3. Measure voltage between terminal 4(2) of glow relay 1(2) harness connector and chassis ground.
 - **Specification: below 0.5V**

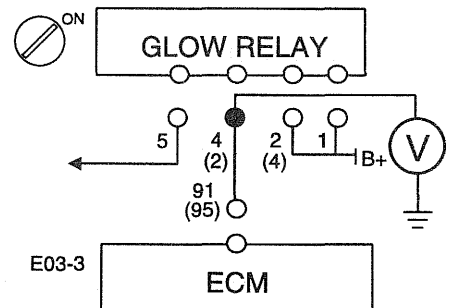

Is(Are) voltage(s) within specification?

(): Glow Relay #2

Yes		No Repair short to power in harness.
------------	--	--------------------------------------

Proceed with "ECM PROBLEM INSPECTION PROCEDURE" in BASIC INSPECTION PROCEDURE.

TROUBLESHOOTING FOR DTC E00C6DA7

DTC	P0381	Glow Indicator Lamp Circuit Malfunction
CC-CODE	0a	Open circuit or short circuit to ground
	03	Short circuit to battery line

DESCRIPTION

Glow plugs in the diesel engine are small 12 V heating elements with the tip exposed to a small chamber where the volume of air can readily be heated. When the diesel engine is started up, the glow plug preheating current is controlled, taking into account factors such as coolant temperature.

In addition to shortening preheating time, the surface temperature of the glow plug is maintained at a fixed temperature after the engine has been started. This has the effect of stabilizing engine speed and reducing the amount of smoke. The preheating warning light (Glow Indicator Lamp), which is located on the cluster, notifies the driver that the ECM is preheating it to improve the driving performance.

DTC DETECTING CONDITION

CC-CODE	Detecting Condition	Suspect Area
0a	<ul style="list-style-type: none"> Open or short to ground in glow indicator lamp circuit 	<ul style="list-style-type: none"> Open or short in Glow Indicator Lamp circuit Glow Indicator Lamp ECM
03	<ul style="list-style-type: none"> Short to battery line in glow indicator lamp circuit 	

[SCHEMATIC DIAGRAM]

[CIRCUIT DIAGRAM]

The diagram shows a glow lamp with two terminals. Terminal 12 is connected to the ECM (E03-1) at terminal 29, labeled 'Glow Lamp Control'. Terminal 14 is connected to the 'IG ON' line.

[CONNECTION INFORMATION]

Terminal	Connected to	Function
12	ECM E03-1 (29)	Glow Lamp Control
14	IG	Battery Voltage

[HARNESS CONNECTORS]

I03-1
CLUSTER

1	5	9	13	17	21	25	●
2	6	10	14	18	22	26	30
3	7	11	15	19	23	27	31
4	8	12	16	20	24	28	32

E03-1
ECM

INSPECTION PROCEDURE

1. CHECK GLOW INDICATOR LAMP (CLUSTER) AND ECM CONNECTORS

1. Thoroughly check connectors for looseness, poor connection, bending, corrosion, contamination, deterioration, or damage.
 - Refer to "CONNECTOR INSPECTION PROCEDURE" in BASIC INSPECTION PROCEDURE.

Are all connectors good?

Yes		
	No	Repair or replace it.

2. CHECK REFERENCE VOLTAGE TO GLOW INDICATOR LAMP

1. Turn ignition switch to OFF and disconnect glow indicator lamp (cluster) connector.
2. Turn ignition switch to ON.
3. Measure voltage in harness between terminal 14 of glow indicator lamp (cluster) harness connector and chassis ground.
 - **Specification: approximately B+**

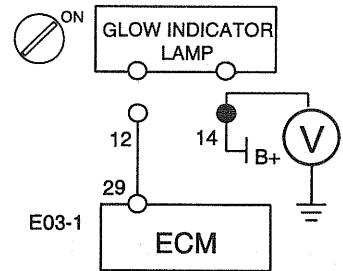

Is(Are) voltage(s) within specification?

Yes		
	No	Repair open or short circuit in harness.

3. CHECK FOR OPEN IN HARNESS

1. Turn ignition switch to OFF, and then disconnect ECM and glow indicator lamp (cluster) connector.
2. Measure resistance between terminal 12 of glow indicator lamp (cluster) harness connector and terminal E03-1(29) of ECM harness connector.
 - **Specification: below 1Ω**

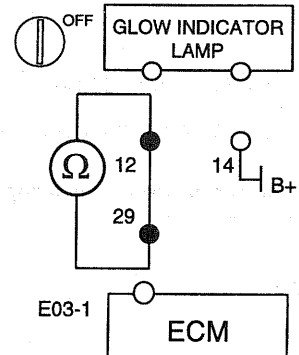

Is(Are) resistance(s) within specification?

Yes		
	No	Repair open circuit in harness.

4. CHECK FOR SHORT TO GROUND IN HARNESS

1. Turn ignition switch to OFF, and then disconnect ECM and glow indicator lamp (cluster) connector.
2. Measure resistance between terminal 12 of glow indicator lamp (cluster) harness connector and chassis ground.
 - **Specification: infinite**

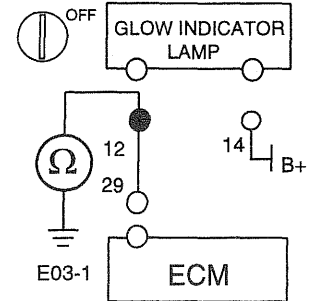

Is(Are) resistance(s) within specification?

Yes	No	Repair short or short to chassis ground in harness.
------------	----	---

5. CHECK FOR SHORT TO POWER IN HARNESS

1. Turn ignition switch to OFF, and then disconnect ECM and glow indicator lamp (cluster) connector.
2. Turn ignition switch to ON.
3. Measure voltage between terminal 12 of glow indicator lamp (cluster) harness connector and chassis ground.
 - **Specification: below 0.5V**

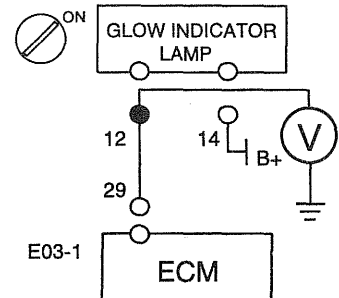

Is(Are) voltage(s) within specification?

Yes	No	Repair short to power in harness.
------------	----	-----------------------------------

6. CHECK GLOW INDICATOR LAMP

1. Inspect the glow indicator lamp installed on the cluster.

Does the glow indicator lamp have normal condition?

Yes	No	Replace the glow indicator lamp
------------	----	---------------------------------

Proceed with "ECM PROBLEM INSPECTION PROCEDURE" in BASIC INSPECTION PROCEDURE.

TROUBLESHOOTING FOR DTC E5DD1E09

DTC	P0400	EGR Solenoid Valve Circuit Malfucntion
CC-CODE	0a	Open circuit or short circuit to ground
	03	Short circuit to battery line

DESCRIPTION

The exhaust-gas recirculation (EGR) system is designed to introduce exhaust gas into the engine's intake manifold. Up to a certain degree, this system enables to reduce the formation of oxides of nitrogen (NOx) by cooling the combustion process. EGR solenoid valve will not open under all driving conditions. For it to cycle, the engine must be at normal operating temperature and not under heavy load. The amount and timing of exhaust gas introduced into the combustion cycle varies by such factors as engine

vacuum, exhaust system back pressure, coolant temperature and accel position. Depending upon the engine's operating point, the air/gas mass drawn into the cylinders can be composed of up to 40%exhaust gas. Using the signal generated by the ECM control circuit, the EGR valve opens so that exhaust gas can flow into the intake manifold. If the EGR valve begins to clog or only partially opens, its flow will be reduced and emissions will increase.

DTC DETECTING CONDITION

CC-CODE	Detecting Condition	Suspect Area
0a	<ul style="list-style-type: none"> EGR solenoid valve duty > 95% 	<ul style="list-style-type: none"> Open or short in EGR Solenoid Valve circuit EGR Solenoid Valve ECM
03	<ul style="list-style-type: none"> EGR solenoid valve duty < 5% 	

SPECIFICATION

EGR Solenoid Valve Resistance (Ω)	15.0 ~ 16.0Ω at 20°C (68°F)
-----------------------------------	-----------------------------

[SCHEMATIC DIAGRAM]

[CIRCUIT DIAGRAM]

[CONNECTION INFORMATION]

Terminal	Connected to	Function
1	ECM E03-2 (39)	EGR Solenoid Valve Control
2	Main Relay	Battery Voltage

[HARNESS CONNECTORS]

E34
EGR Solenoid Valve Control

33	37	41	45	49	53	57	61	65	69	73	77
34	38	42	46	50	54	58	62	66	70	74	78
35		43	47	51	55	59	63	67	71	75	79
36	40	44	48	52	56	60	64	68	72	76	80

E03-2
ECM

INSPECTION PROCEDURE

1. CHECK EGR SOLENOID VALVE AND ECM CONNECTORS

1. Thoroughly check connectors for looseness, poor connection, bending, corrosion, contamination, deterioration, or damage.
 - Refer to "CONNECTOR INSPECTION PROCEDURE" in BASIC INSPECTION PROCEDURE.

Are all connectors good?

Yes		
No		Repair or replace it.

2. CHECK REFERENCE VOLTAGE TO EGR SOLENOID VALVE

1. Turn ignition switch to OFF and disconnect EGR solenoid valve connector.
2. Turn ignition switch to ON.
3. Measure voltage in harness between terminal 2 of EGR solenoid valve harness connector and chassis ground.
 - Specification: approximately B+

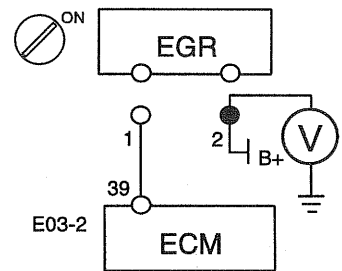

Is(Are) voltage(s) within specification?

Yes		
No		Repair open or short circuit in harness.

3. CHECK FOR OPEN IN HARNESS

1. Turn ignition switch to OFF, and then disconnect ECM and EGR solenoid valve connector.
2. Measure resistance between terminal 1 of EGR solenoid valve harness connector and terminal E03-2(39) of ECM harness connector.
 - Specification: below 1Ω

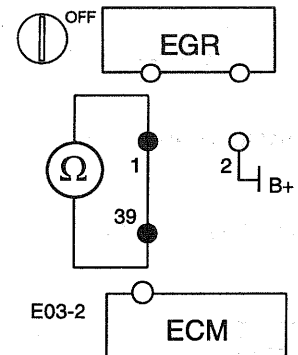

Is(Are) resistance(s) within specification?

Yes		
No		Repair open circuit in harness

4. CHECK FOR SHORT TO GROUND IN HARNESS

1. Turn ignition switch to OFF, and then disconnect ECM and EGR solenoid valve connector.
2. Measure resistance between terminal 1 of EGR solenoid valve harness connector and chassis ground.
 - **Specification: infinite**

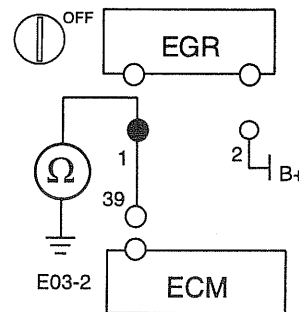

Is(Are) resistance(s) within specification?

Yes

No	Repair short or short to chassis ground in harness.
----	---

5. CHECK FOR SHORT TO POWER IN HARNESS

1. Turn ignition switch to OFF, and then disconnect ECM and EGR solenoid valve connector.
2. Turn ignition switch to ON.
3. Measure voltage between terminal 1 of EGR solenoid valve harness connector and chassis ground.
 - **Specification: below 0.5V**

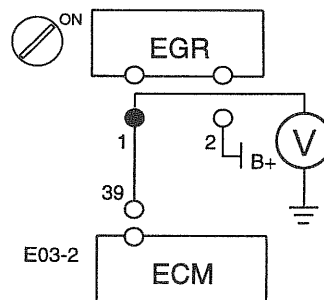

Is(Are) voltage(s) within specification?

Yes

No	Repair short to power in harness.
----	-----------------------------------

6. CHECK EGR SOLENOID VALVE

1. Turn ignition switch to OFF and disconnect EGR solenoid valve connector.
2. Measure resistance between terminal 1 and 2 of EGR solenoid valve connector.
 - **Refer to "SPECIFICATION" for more information.**

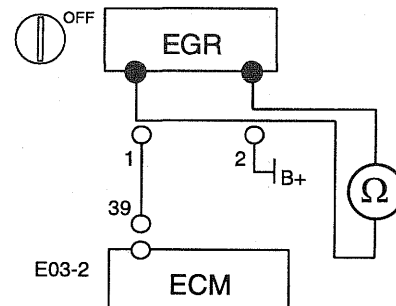

Is(Are) resistance(s) within specification?

Yes

No	Replace the EGR solenoid valve
----	--------------------------------

Proceed with "ECM PROBLEM INSPECTION PROCEDURE" in BASIC INSPECTION PROCEDURE.

TROUBLESHOOTING FOR DTC E5DF4755

DTC	P0560	Battery Voltage Malfunction
CC-CODE	08	Battery voltage too low
	09	Battery voltage too high

DESCRIPTION

The charging system includes a battery, generator with a built in regulator, the charging indicator light, and connecting wiring. The generator uses diodes to rectify alternating current (AC) to direct current (DC). The ECM provides ground to one side of coil of main relay and the other side

is connected to battery. The ECM monitors battery voltage and the voltage after main relay.

DTC DETECTING CONDITION

CC-CODE	Detecting Condition	Suspect Area
08	• Battery voltage < 6V at engine speed = 700 rpm	<ul style="list-style-type: none"> • Open or short in Main Relay circuit • Main Relay • Battery • Alternator • ECM
09	• Battery voltage > 18V at engine speed = 700 rpm	

[SCHEMATIC DIAGRAM]

[CIRCUIT DIAGRAM]

[CONNECTION INFORMATION]

Terminal	Connected to	Function
1	Battery	Battery Voltage
2	ECM E03-3 (104)	Main Relay Control
3	-	-
4	Battery	Battery Voltage
5	-	-

[HARNESS CONNECTORS]

E113
MAIN RELAY

81	85	89	93	97	101	105	109
82	86	90	94	98	102	106	110
						107	111
83	87	91	95	99	103		
84	88	92	96	100	104	108	112

E03-3
ECM

INSPECTION PROCEDURE

1. CHECK MAIN RELAY, BATTERY CABLE AND ECM CONNECTORS

1. Thoroughly check connectors for looseness, poor connection, bending, corrosion, contamination, deterioration, or damage.
 - Refer to "CONNECTOR INSPECTION PROCEDURE" in BASIC INSPECTION PROCEDURE.

Are all connectors good?

Yes		No Repair or replace it.
-----	--	--------------------------

2. CHECK MAIN RELAY

1. Turn ignition switch to OFF and remove the main relay.
2. Apply power to the terminal 4 and ground terminal 2 of main relay.
3. Check if main relay works well.
 - (If main relay works normally, a "click" sound can be heard).

Does the main relay operate normally?

Yes		No Replace the glow plug relay
-----	--	--------------------------------

3. CHECK POWER TO MAIN RELAY

1. Turn ignition switch to OFF and disconnect main relay connector.
2. Turn ignition switch to ON.
3. Measure voltage in harness between terminal 4 of main relay harness connector and chassis ground.
4. Measure voltage in harness between terminal 1 of main relay harness connector and chassis ground.
 - Specification: approximately B+

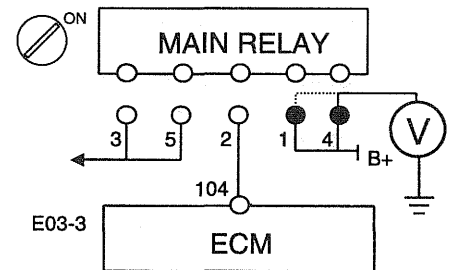

Is(Are) voltage(s) within specification?

Yes		No Repair open or short circuit in harness.
-----	--	---

4. CHECK FOR OPEN IN HARNESS

1. Turn ignition switch to OFF, and then disconnect ECM and main relay connector.
2. Measure resistance between terminal 2 of main relay harness connector and terminal E03-3(104) of ECM harness connector.
 - Specification: below 1Ω

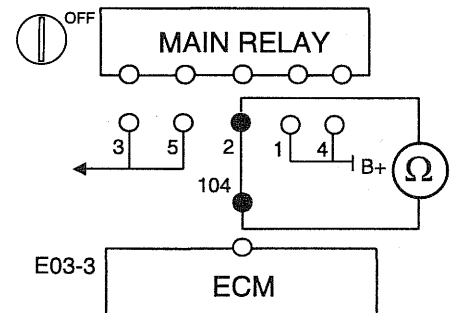

Is(Are) resistance(s) within specification?

Yes

No	Repair open circuit in harness.
----	---------------------------------

5. CHECK FOR SHORT TO GROUND IN HARNESS

1. Turn ignition switch to OFF, and then disconnect ECM and main relay connector.
2. Measure resistance between terminal 2 of main relay harness connector and chassis ground.
 - **Specification: infinite**

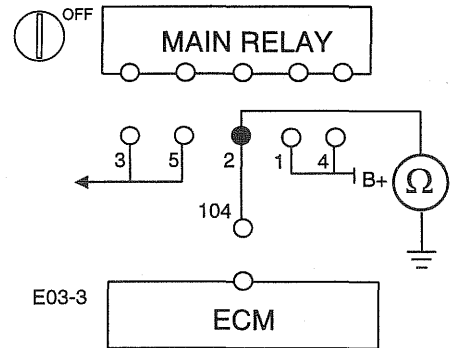

Is(Are) resistance(s) within specification?

Yes

No	Repair short or short to chassis ground in harness.
----	---

6. CHECK FOR SHORT TO POWER IN HARNESS

1. Turn ignition switch to OFF, and then disconnect ECM and main relay connector.
2. Turn ignition switch to ON.
3. Measure voltage between terminal 2 of main relay harness connector and chassis ground.
 - **Specification: below 0.5V**

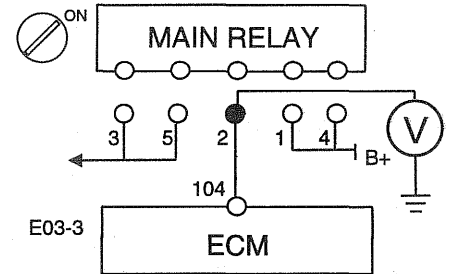

Is(Are) voltage(s) within specification?

Yes

No	Repair short to power in harness.
----	-----------------------------------

7. CHECK BATTERY

1. Check battery.
 - **Refer to the group "EE" in this Shop Manual.**

Is battery okay?

Yes

No	Repair or replace it.
----	-----------------------

8. CHECK ALTERNATOR

- 1. Check alternator.
 - Refer to the group "EE" in this Shop Manual.

Is alternator okay?



No	Repair or replace it.
----	-----------------------

Proceed with "ECM PROBLEM INSPECTION PROCEDURE" in BASIC INSPECTION PROCEDURE.

TROUBLESHOOTING FOR DTC EC60D8FC

DTC	P0650	Malfunction Indicator Lamp Circuit Malfunction
CC-CODE	0a	Open circuit or short circuit to ground
	03	Short circuit to battery line

DESCRIPTION

The Malfunction Indicator Lamp (MIL), which is located in the instrument cluster, comes on to notify the driver that there may be a problem with the vehicle and that service is needed. Immediately after the ignition switch turns on, the

malfunction indicator lamp is lit for 5 seconds to indicate that the MIL operates normally.

DTC DETECTING CONDITION

CC-CODE	Detecting Condition	Suspect Area
0a	• Open or short to ground in MIL circuit	• Open or short in MIL circuit • MIL • ECM
03	• Short to battery line in MIL circuit	

[SCHEMATIC DIAGRAM]

[CIRCUIT DIAGRAM]

The diagram shows a box labeled 'MIL' containing a lamp symbol. A line labeled '20' connects the lamp to a box labeled 'ECM'. Inside the ECM box, the connection is labeled '9 - MIL Control'. Another line labeled '9' connects the ECM to 'IG ON'.

[CONNECTION INFORMATION]

Terminal	Connected to	Function
20	ECM E03-1 (9)	MIL Control
9	IG	Battery Voltage

[HARNESS CONNECTORS]

10	9	8	7	6	5	4	3	2	1
20	19	18	17	16	15	14	13	12	11

I03-3
CLUSTER

1	5	●	13	17	21	25	29
2	6		10	14	18	22	30
3	7		11	15	19	23	27
4	8		12	16	20	24	28

E03-1
ECM

INSPECTION PROCEDURE

1. CHECK MIL(CLUSTER) AND ECM CONNECTORS

1. Thoroughly check connectors for looseness, poor connection, bending, corrosion, contamination, deterioration, or damage.
 - Refer to "CONNECTOR INSPECTION PROCEDURE" in BASIC INSPECTION PROCEDURE.

Are all connectors good?

Yes		No	Repair or replace it.
------------	--	----	-----------------------

2. CHECK POWER TO MIL

1. Turn ignition switch to OFF and disconnect MIL(Cluster) connector.
2. Turn ignition switch to ON.
3. Measure voltage in harness between terminal 9 of MIL(Cluster) harness connector and chassis ground.
 - **Specification: approximately B+**

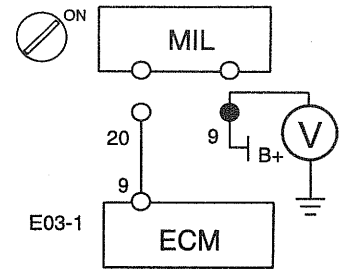

Is(Are) voltage(s) within specification?

Yes		No	Repair open or short circuit in harness.
------------	--	----	--

3. CHECK FOR OPEN IN HARNESS

1. Turn ignition switch to OFF, and then disconnect ECM and MIL(Cluster) connector.
2. Measure resistance between terminal 20 of MIL(Cluster) harness connector and terminal E03-1(9) of ECM harness connector.
 - **Specification: below 1Ω**

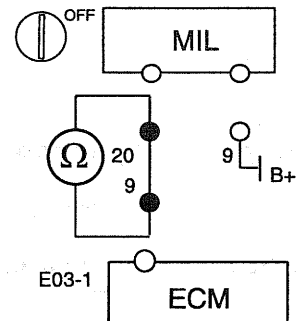

Is(Are) resistance(s) within specification?

Yes		No	Repair open circuit in harness.
------------	--	----	---------------------------------

4. CHECK FOR SHORT TO GROUND IN HARNESS

1. Turn ignition switch to OFF, and then disconnect ECM and MIL(Cluster) connector.
2. Measure resistance between terminal 20 of MIL(Cluster) harness connector and chassis ground.
 - **Specification: infinite**

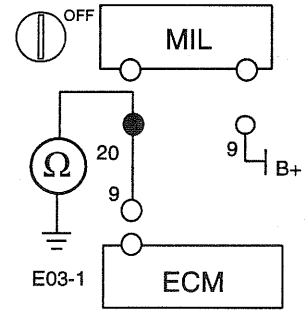

Is(Are) resistance(s) within specification?

Yes	No	Repair short or short to chassis ground in harness.
------------	----	---

5. CHECK FOR SHORT TO POWER IN HARNESS

1. Turn ignition switch to OFF, and then disconnect ECM and MIL(Cluster) connector.
2. Turn ignition switch to ON.
3. Measure voltage between terminal 20 of MIL(Cluster) harness connector and chassis ground.
 - **Specification: below 0.5V**

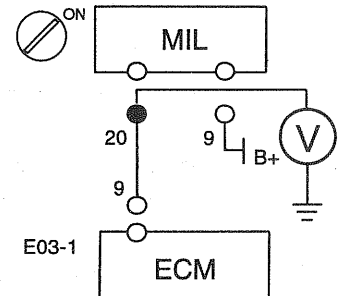

Is(Are) voltage(s) within specification?

Yes	No	Repair short to power in harness.
------------	----	-----------------------------------

6. CHECK MIL(CLUSTER)

1. Inspect the MIL installed on the cluster.

Does the MIL have normal condition?

Yes	No	Replace the MIL.
------------	----	------------------

Proceed with "ECM PROBLEM INSPECTION PROCEDURE" in BASIC INSPECTION PROCEDURE.

TROUBLESHOOTING FOR DTC EDE9BA65

DTC	P1119	Inlet Metering Valve (IMV) Control Malfunction
CC-CODE	96	Fuel leakage
	97	Fuel leakage
	98	Fuel leakage)
	99	Fuel leakage

DTC	P1120	Inlet Metering Valve (IMV) Circuit Malfunction
CC-CODE	0a	Open circuit or short circuit to ground
	03	Short circuit to battery line
	05	Fuel leakage
	04	Fuel leakage
	08	Fuel leakage

DESCRIPTION

The Inlet Metering Valve (IMV) is used to control the rail pressure by regulating the amount of fuel which is sent to the pumping element of the HP pump. This IMV has two purposes:

1. Firstly, it allows the efficiency of the injection system to be improved, since the HP pump only compresses the amount of fuel necessary to maintain in the rail the level of pressure required by the system as a function of the engine operating conditions.
2. Secondly, it allows the temperature to be reduced in the fuel tank. When the excess fuel is discharged into the back leak circuit, the pressure reduction in the fluid (from rail pressure down to atmospheric pressure) gives off a large amount of heat. This leads to a temperature rise in the fuel entering the tank. In order to prevent too high a temperature being reached, it is necessary to limit the amount of heat generated by the fuel pressure reduction, by reducing the back leak flow. To reduce the back leak flow, it is sufficient to adapt the flow of the HP pump to the engine requirements throughout its operating range.

[FIG 1] Inlet Metering Valve Effect

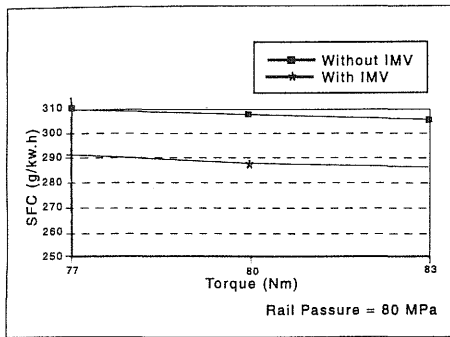

[FIG 2] Fuel Temperature at System Backleak

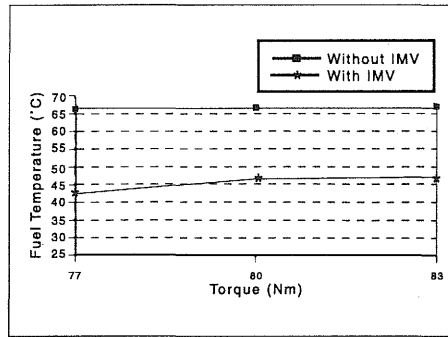

[FIG 3] Operation Principle

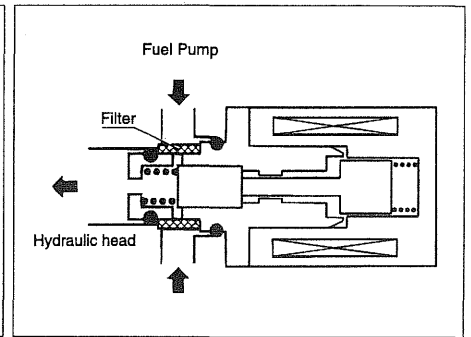

EWMF203R

DTC DETECTING CONDITION

(P1119)

CC-CODE	Detecting Condition	Suspect Area
96	<ul style="list-style-type: none"> The rail pressure is slightly lower than the demand. 	<ul style="list-style-type: none"> Open or short in IMV circuit IMV High pressure fuel circuit Low pressure fuel circuit Injector High pressure pump ECM
97		
98		
99	<ul style="list-style-type: none"> The rail pressure is slightly higher than the demand. 	

(P1120)

CC-CODE	Detecting Condition	Suspect Area
0a	<ul style="list-style-type: none"> Open or short to ground in IMV circuit 	<ul style="list-style-type: none"> Open or short in IMV circuit IMV High pressure fuel circuit Low pressure fuel circuit Injector High pressure pump ECM
03	<ul style="list-style-type: none"> Short to battery line in IMV circuit 	
05	<ul style="list-style-type: none"> The rail pressure remains 101.9 kgf/cm² above the demand for a variable time depending on the difference. 	
04	<ul style="list-style-type: none"> The rail pressure remains 101.9 kgf/cm² below the demand for a variable time depending on the difference. 	
08	<ul style="list-style-type: none"> The pressure rise on starting is too slow. 	

SPECIFICATION

Inlet Metering Valve Resistance (Ω)	5.5Ω at 20°C (68°F)
-------------------------------------	---------------------

[SCHEMATIC DIAGRAM]

[CIRCUIT DIAGRAM]

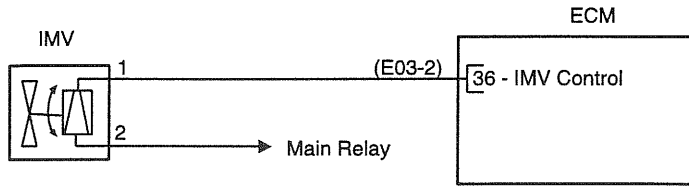

[CONNECTION INFORMATION]

Terminal	Connected to	Function
1	ECM E03-2 (36)	IMV Control
2	Main Relay	Battery Voltage

[HARNESS CONNECTORS]

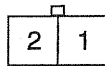

E86
IMV

33	37	41	45	49	53	57	61	65	69	73	77
34	38	42	46	50	54	58	62	66	70	74	78
35	39	43	47	51	55	59	63	67	71	75	79
●	40	44	48	52	56	60	64	68	72	76	80

E03-2
ECM

INSPECTION PROCEDURE

1. CHECK DTC

1. Connect the Hi-Scan (Pro) to the Data Link Connector (DLC).
2. Turn ignition switch to ON and check that any other DTC(s) is (are) detected.

Is P0190 also set?

Yes	No	Do all repairs associated with those codes before proceeding with this procedure.
------------	----	---

2. CHECK IMV AND ECM CONNECTORS

1. Thoroughly check connectors for looseness, poor connection, bending, corrosion, contamination, deterioration, or damage.
 - Refer to "CONNECTOR INSPECTION PROCEDURE" in BASIC INSPECTION PROCEDURE.

Are all connectors good?

Yes	No	Repair or replace it.
------------	----	-----------------------

3. CHECK POWER TO IMV

1. Turn ignition switch to OFF and disconnect IMV connector.
2. Turn ignition switch to ON.
3. Measure voltage in harness between terminal 2 of IMV harness connector and chassis ground.
 - **Specification: approximately B+**

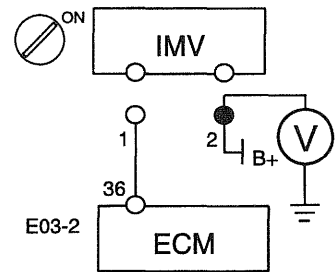

Is(Are) voltage(s) within specification?

Yes	No	Repair open or short circuit in harness.
------------	----	--

4. CHECK FOR OPEN IN HARNESS

1. Turn ignition switch to OFF, and then disconnect ECM and IMV connector.
2. Measure resistance between terminal 1 of IMV harness connector and terminal E03-2(36) of ECM harness connector.
 - **SSpecification: below 1Ω**

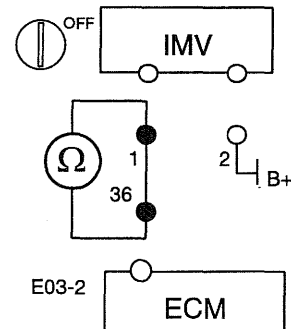

Is(Are) resistance(s) within specification?

Yes

No	Repair open circuit in harness.
----	---------------------------------

5. CHECK FOR SHORT TO GROUND IN HARNESS

1. Turn ignition switch to OFF, and then disconnect ECM and IMV connector.
2. Measure resistance between terminal 1 of IMV harness connector and chassis ground.
 - **Specification: infinite**

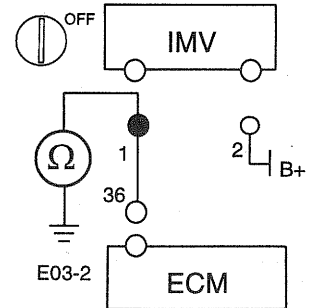

Is(Are) resistance(s) within specification?

Yes

No	Repair short or short to chassis ground in harness.
----	---

6. CHECK FOR SHORT TO POWER IN HARNESS

1. Turn ignition switch to OFF, and then disconnect ECM and IMV connector.
2. Turn ignition switch to ON.
3. Measure voltage between terminal 1 of IMV harness connector and chassis ground.
 - **Specification: below 0.5V**

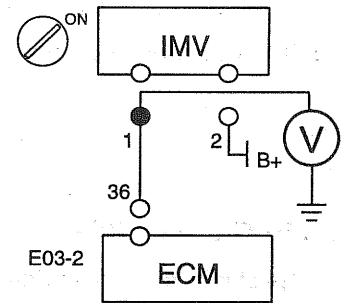

Is(Are) voltage(s) within specification?

Yes

No	Repair short to power in harness.
----	-----------------------------------

7. CHECK IMV

1. Turn ignition switch to OFF and disconnect IMV connector.
2. Measure resistance between terminal 1 and 2 of IMV connector.
 - **Refer to "SPECIFICATION" for more information.**

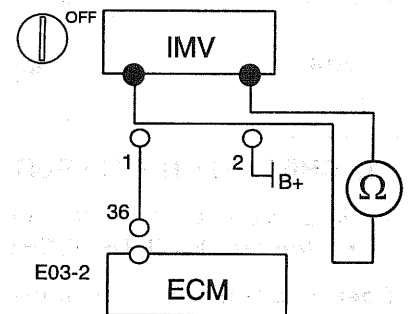

Is(Are) resistance(s) within specification?

Yes

No

Replace the IMV

8. CHECK LOW PRESSURE FUEL CIRCUIT

1. Inspect following items:
 - The presence of fuel in fuel tank
 - Leakage and connection condition of fuel line from fuel tank to high pressure pump
 - Leakage and connection condition of fuel line from fuel tank to injector via high pressure pump
 - The absence of air in the low pressure circuit (If air exists, place a receptacle under the venturi, and then disconnect the pump return hose at the venturi and prime the fuel circuit with the hand-priming pump).

Are all system above normal?

Yes

No

Repair or replace it.

9. CHECK HIGH PRESSURE FUEL CIRCUIT

1. Inspect high pressure fuel circuit.
 - Refer to "FUEL DELIVERY SYSTEM-DIESEL".

Does it have normal condition?

Yes

No

Repair or replace it.

10. CHECK INJECTOR

1. Inspect injector as following.
 - Operation condition of injector
 - Leakage on injector
 - Fuel amount of injector return line
 - Installation condition of injector (including the injector gasket and the tightening torques of clamp)
 - Refer to "FUEL DELIVERY SYSTEM-DIESEL".

Are all system above normal?

Yes

No

Repair or replace it.

11. CHECK HIGH PRESSURE PUMP

1. Inspect operation condition of high pressure pump.
 - Refer to "FUEL DELIVERY SYSTEM-DIESEL".

Does it have normal condition?

Yes

No

Repair or replace it.

Proceed with "ECM PROBLEM INSPECTION PROCEDURE" in BASIC INSPECTION PROCEDURE.

TROUBLESHOOTING FOR DTC E771E34A

DTC	P1140	Intake Air Temperature Sensor (IATS) Circuit Malfunction
CC-CODE	0b	Signal low (Open circuit or short circuit to battery line)
	02	Signal high (Short circuit to ground)

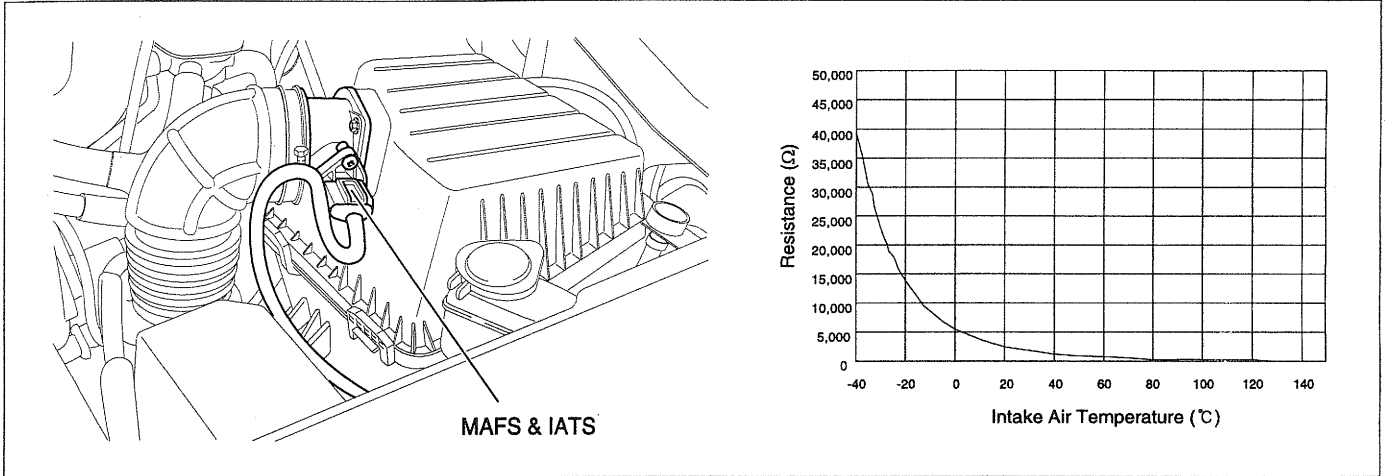

EWMF201Z

DESCRIPTION

The intake air temperature sensor (IATS) is built in the mass air flowmeter sensor (MAFS). It is located between the air cleaner assembly and the throttle device. The IATS uses a thermistor whose resistance changes with the temperature to check the mass of intake air entering the engine.

The electrical resistance of the IATS decreases as the temperature increases, and increases as the temperature decreases. The 5 V power source in the ECM is supplied

to the IATS via a resistor in the ECM. That is, the resistor in the ECM and the thermistor in the IATS are connected in series. When the resistance value of the thermistor in IATS changes according to the intake air temperature, the signal voltage also changes. Using this signal, the information of the intake air temperature, the ECM corrects fuel flow, injection timing.

DTC DETECTING CONDITION

CC-CODE	Detecting Condition	Suspect Area
0b	<ul style="list-style-type: none"> Intake air temperature < -49°C(-56.2°F) 	<ul style="list-style-type: none"> Open or short in IATS circuit IATS ECM
02	<ul style="list-style-type: none"> Intake air temperature > 130°C(266°F) 	

SPECIFICATION

Temperature [°C (°F)]	-40(-40)	-20(-4)	0(32)	20(68)	40(104)	60(140)	80(176)
Resistance (kΩ)	39.3	13.9	5.5	2.4	1.2	0.6	0.3

[SCHEMATIC DIAGRAM]

[CIRCUIT DIAGRAM]

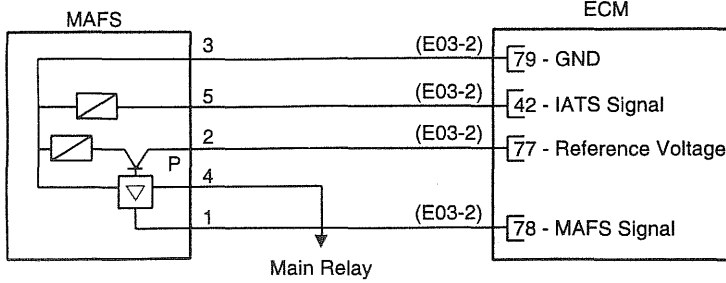

[CONNECTION INFORMATION]

Terminal	Connected to	Function
1	ECM E03-2 (78)	MAFS Signal
2	ECM E03-2 (77)	Reference Voltage
3	ECM E03-2 (79)	Sensor Ground
4	Main Relay	Battery Voltage
5	ECM E03-2 (42)	IATS Signal

[HARNESS CONNECTORS]

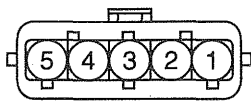

E17
MAFS & IATS

33	37	41	45	49	53	57	61	65	69	73	●
34	38	●	46	50	54	58	62	66	70	74	●
35	39										
		43	47	51	55	59	63	67	71	75	●
36	40	44	48	52	56	60	64	68	72	76	80

E03-2
ECM

INSPECTION PROCEDURE

1. CHECK IATS AND ECM CONNECTORS

1. Thoroughly check connectors for looseness, poor connection, bending, corrosion, contamination, deterioration, or damage.
 - Refer to "CONNECTOR INSPECTION PROCEDURE" in BASIC INSPECTION PROCEDURE.

Are all connectors good?

Yes	No	Repair or replace it.
------------	----	-----------------------

2. CHECK REFERENCE VOLTAGE TO IATS

1. Turn ignition switch to OFF and disconnect IATS connector.
2. Turn ignition switch to ON.
3. Measure voltage in harness between terminal 5 of IATS harness connector and chassis ground.
 - **Specification: approximately 5V**

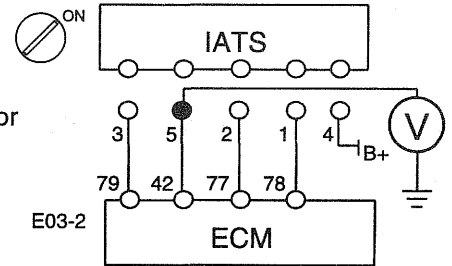

Is(Are) voltage(s) within specification?

Yes	No	Repair open or short circuit in harness.
------------	----	--

3. CHECK FOR OPEN IN HARNESS

1. Turn ignition switch to OFF, and then disconnect ECM and IATS connector.
2. Measure resistance between terminal 5 of IATS harness connector and terminal E03-2(42) of ECM harness connector.
3. Measure resistance between terminal 3 of IATS harness connector and terminal E03-2(79) of ECM harness connector.
 - **Specification: below 1Ω**

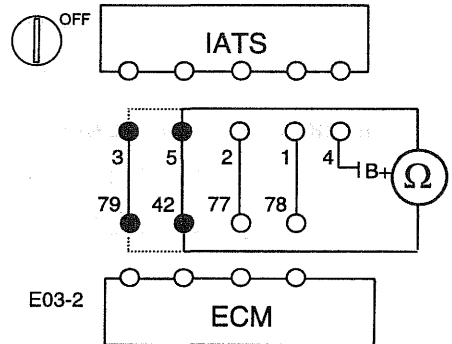

Is(Are) resistance(s) within specification?

Yes	No	Repair open circuit in harness.
------------	----	---------------------------------

4. CHECK FOR SHORT TO GROUND IN HARNESS

1. Turn ignition switch to OFF, and then disconnect ECM and IATS connector.
2. Measure resistance between terminal 5 of IATS harness connector and chassis ground.
3. Measure resistance between terminal 5 and 3 of IATS harness connector.
 - **Specification: infinite**

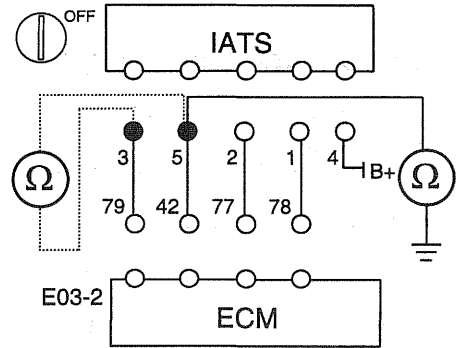

Is(Are) resistance(s) within specification?

Yes

No	Repair short or short to chassis ground in harness.
----	---

5. CHECK FOR SHORT TO POWER IN HARNESS

1. Turn ignition switch to OFF, and then disconnect ECM and IATS connector.
2. Turn ignition switch to ON.
3. Measure voltage between terminal 5 of IATS harness connector and chassis ground.
 - **Specification: below 0.5V**

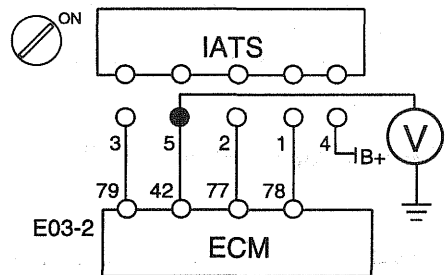

Is(Are) voltage(s) within specification?

Yes

No	Repair short to power in harness.
----	-----------------------------------

6. CHECK IATS RESISTANCE

1. Turn ignition switch to OFF and disconnect IATS connector.
2. Measure resistance between terminal 5 and 3 of IATS connector.
 - **Refer to "SPECIFICATION" for more information.**

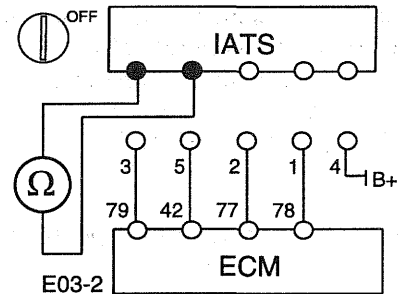

Is(Are) resistance(s) within specification?

Yes

No	Replace the IATS.
----	-------------------

Proceed with "ECM PROBLEM INSPECTION PROCEDURE" in BASIC INSPECTION PROCEDURE.

TROUBLESHOOTING FOR DTC E32031F0

DTC	P1150	Atmospheric Pressure Sensor Fault
CC-CODE	0a	Signal low (Open circuit or short circuit to ground)
	03	Signal high (Short circuit to battery line)

DTC DETECTING CONDITION

CC-CODE	Detecting Condition	Suspect Area
0a	<ul style="list-style-type: none"> Atmospheric pressure < 0.43 kgf/cm² 	<ul style="list-style-type: none"> Open or short in ECM internal circuit
03	<ul style="list-style-type: none"> Atmospheric pressure > 1.08 kgf/cm² 	

INSPECTION PROCEDURE

Replace the ECM

TROUBLESHOOTING FOR DTC ED6BC73B

DTC	P1300	Injector Specific Data Fault
CC-CODE	04	Injector parameters incorrect

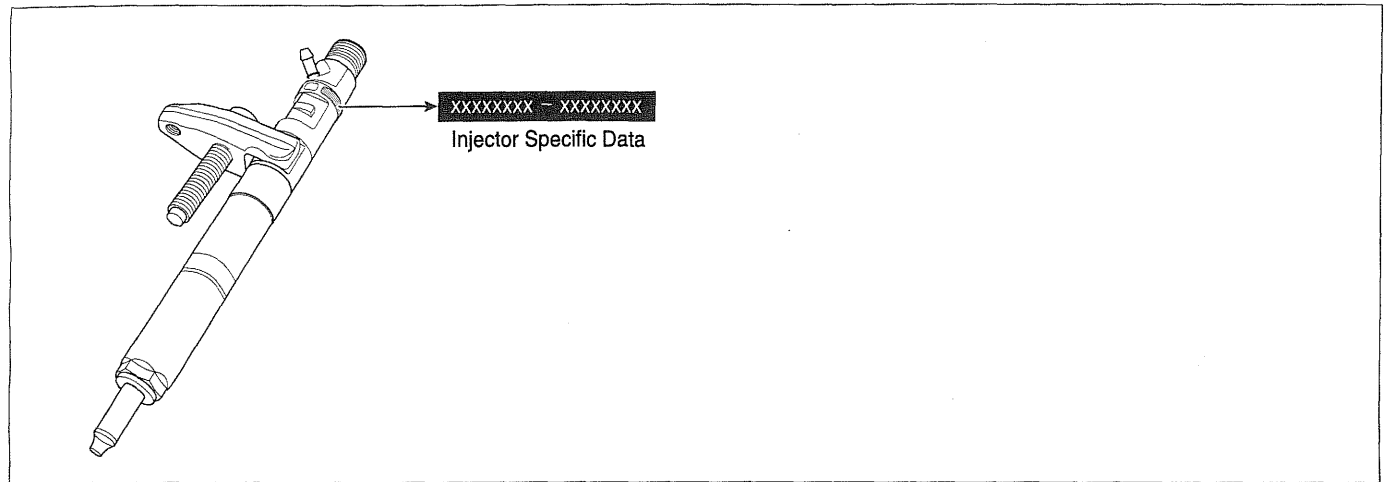

EWMF201X

DTC DETECTING CONDITION

CC-CODE	Detecting Condition	Suspect Area
04	<ul style="list-style-type: none"> • Incorrect injector specific data 	<ul style="list-style-type: none"> • ECM

INSPECTION PROCEDURE

1. VERIFICATION OF INJECTOR SPECIFIC DATA

1. Connect the Hi-Scan (Pro) to the Data Link Connector (DLC).
2. Compare the injector specific data memorized in ECM memory with the one written on injector.

Are the two data same?



No	Input the injector specific data using Hi-Scan (Pro).
----	---

Proceed with "ECM PROBLEM INSPECTION PROCEDURE" in BASIC INSPECTION PROCEDURE.

EWMF201Y

TROUBLESHOOTING FOR DTC E4BCBF5

DTC	P1310	Injector Control Circuit Fault
CC-CODE	03	Short circuit to battery line
	02	Short circuit to ground

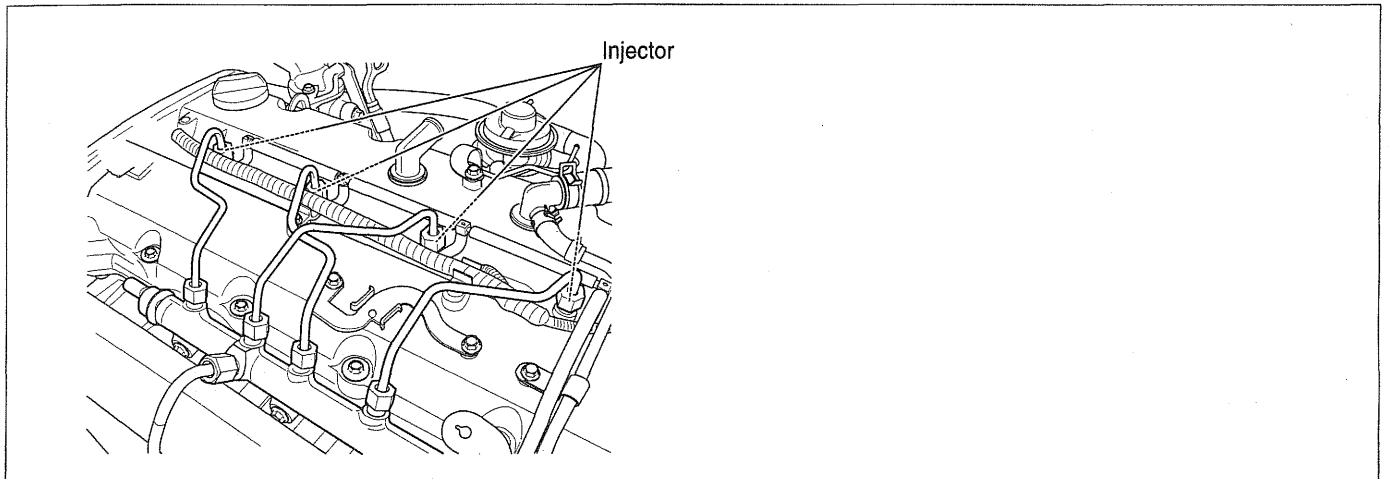

EWMF202M

DESCRIPTION

The injector of the Common Rail System is electronically controlled. It has been designed to allow multiple injection with short intervals, to be fully electronically controlled, and to release a small amount of heat. The nozzle of injector opens when the solenoid valve is triggered and permits the flow of fuel. They inject the fuel directly into the engine's combustion chamber. The fuel is stored in the Rail ready for injection and the injected fuel quantity is defined by the injector opening time and the rail pressure.

The excess fuel, which was needed for opening the nozzle of injector, flows back to the tank through a collector line. The return fuel from the pressure-control valve and from the low-pressure stage is also led into this collector line together with the fuel used to lubricate the high-pressure pump.

DTC DETECTING CONDITION

CC-CODE	Detecting Condition	Suspect Area
03	<ul style="list-style-type: none"> • Short to battery line in injector circuit 	<ul style="list-style-type: none"> • Open or short in injector • Injector • ECM
02	<ul style="list-style-type: none"> • Short to ground in injector circuit 	

[SCHEMATIC DIAGRAM]

[CIRCUIT DIAGRAM]

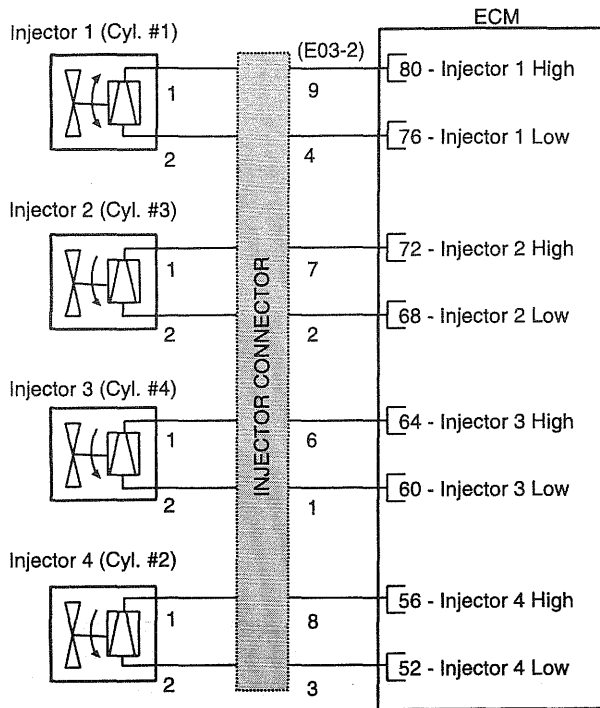

[CONNECTION INFORMATION]

Injector #1 (Cylinder #1)

Terminal	Injector Connector	Connected to	Function
1	7	ECM E03-2 (80)	Injector1 (Cyl. #1) High
2	2	ECM E03-2 (76)	Injector1 (Cyl. #1) Low

Injector #2 (Cylinder #3)

Terminal	Injector Connector	Connected to	Function
1	9	ECM E03-2 (72)	Injector2 (Cyl. #3) High
2	4	ECM E03-2 (68)	Injector2 (Cyl. #3) Low

Injector #3 (Cylinder #4)

Terminal	Injector Connector	Connected to	Function
1	10	ECM E03-2 (64)	Injector3 (Cyl. #4) High
2	5	ECM E03-2 (60)	Injector3 (Cyl. #4) Low

Injector #4 (Cylinder #2)

Terminal	Injector Connector	Connected to	Function
1	8	ECM E03-2 (56)	Injector4 (Cyl. #2) High
2	3	ECM E03-2 (52)	Injector4 (Cyl. #2) Low

[HARNESS CONNECTORS]

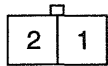

E157
INJECTOR

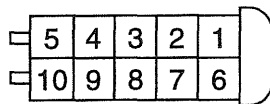

INJECTOR CONNECTOR

33	37	41	45	49	53	57	61	65	69	73	77
34	38	42	46	50	54	58	62	66	70	74	78
35	39										
		43	47	51	55	59	63	67	71	75	79
36	40	44	48	●	●	●	●	●	●	●	●

E03-2
ECM

INSPECTION PROCEDURE

1. CHECK INJECTOR AND ECM CONNECTORS

1. Thoroughly check connectors for looseness, poor connection, bending, corrosion, contamination, deterioration, or damage.
 - Refer to "CONNECTOR INSPECTION PROCEDURE" in BASIC INSPECTION PROCEDURE.

Are all connectors good?

Yes		
No		Repair or replace it.

2. CHECK INJECTOR

1. Connect the Hi-Scan (Pro) to the Data Link Connector (DLC).
2. Turn ignition switch to ON and check that any other DTC(s) is (are) detected.

Is this problem fixed?

No		
Yes		<ol style="list-style-type: none"> 1. Delete the DTC P1310, and then turn ignition switch to OFF and connect the injector connector again. 2. Connect the Hi-Scan (Pro) to the Data Link Connector (DLC). 3. Turn ignition switch to ON and check again that any other DTC(s) is (are) detected. <ul style="list-style-type: none"> • If the DTC P1310 occurs again, replace the injector (injector fault).

3. CHECK FOR SHORT TO GROUND IN HARNESS

1. Turn ignition switch to OFF and wait for about 10 seconds.
2. Disconnect ECM and injector connector.
3. Measure resistance between terminal 1 of injector harness connector and chassis ground.
4. Measure resistance between terminal 2 of injector harness connector and chassis ground.
 - **Specification: infinite**

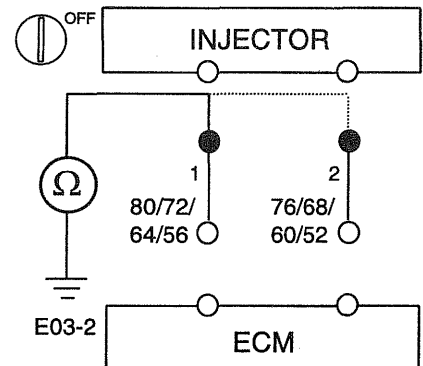

Is(Are) resistance(s) within specification?

Yes		
No		Repair short or short to chassis ground in harness.

4. CHECK FOR SHORT TO POWER IN HARNESS

1. Turn ignition switch to OFF and wait for about 10 seconds.
2. Disconnect ECM and injector connector.
3. Turn ignition switch to ON.
4. Measure voltage between terminal 1 of injector harness connector and chassis ground.
5. Measure voltage between terminal 2 of injector harness connector and chassis ground.
 - **Specification: below 0.5V**

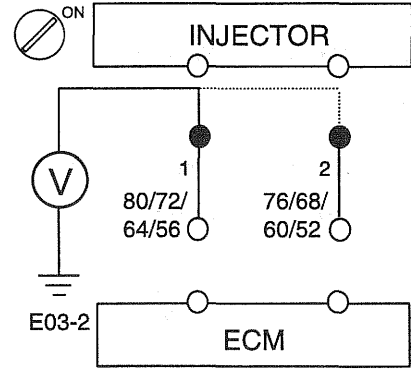

Is(Are) voltage(s) within specification?

Yes

No	Repair short to power in harness.
----	-----------------------------------

Proceed with "ECM PROBLEM INSPECTION PROCEDURE" in BASIC INSPECTION PROCEDURE.

TROUBLESHOOTING FOR DTC EC685BE5

DTC	P1500	Vehicle Speed Sensor (VSS) Circuit Malfunction
CC-CODE	06	Abnormal signal after running
	06	Abnormal signal after running
	06	Abnormal signal after running
	07	No signal before running

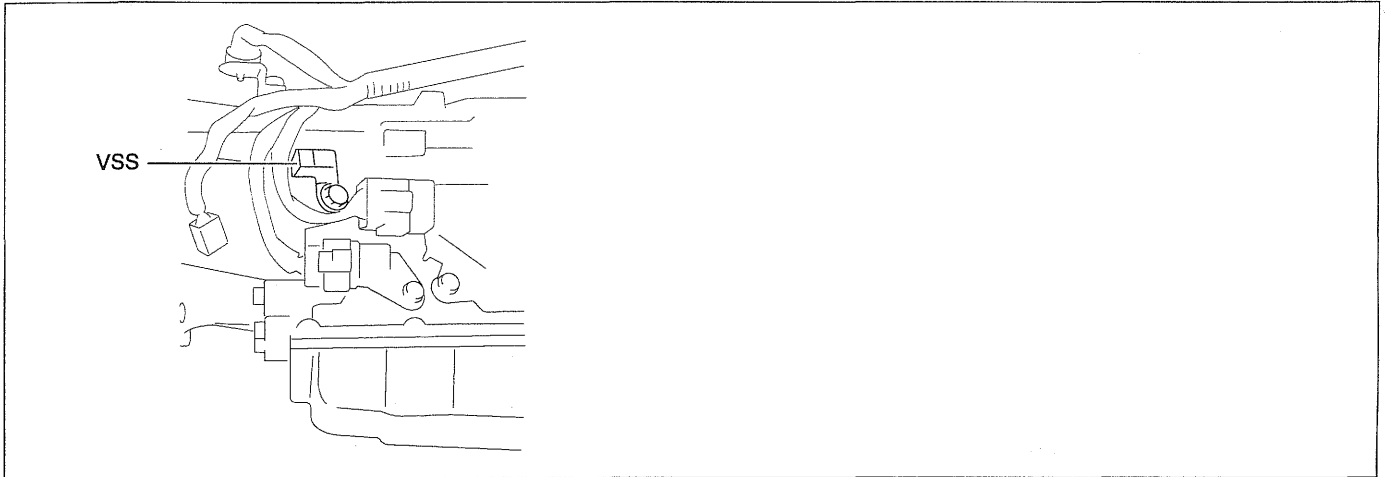

EWMF203Z

DESCRIPTION

The function of vehicle speed sensor (VSS) is to sense the tooth signal in T/M housing (4 pulses signal for every revolution of the rotor shaft) and send relevant signal to the Engine control module(ECM). The signal is used for

computing the vehicle speed and the speed display on the tachometer as well.

DTC DETECTING CONDITION

CC-CODE	Detecting Condition	Suspect Area
06	<ul style="list-style-type: none"> • Open or short in VSS circuit • VSS fault 	<ul style="list-style-type: none"> • Open or short in VSS circuit • VSS • ECM
07		

[SCHEMATIC DIAGRAM]

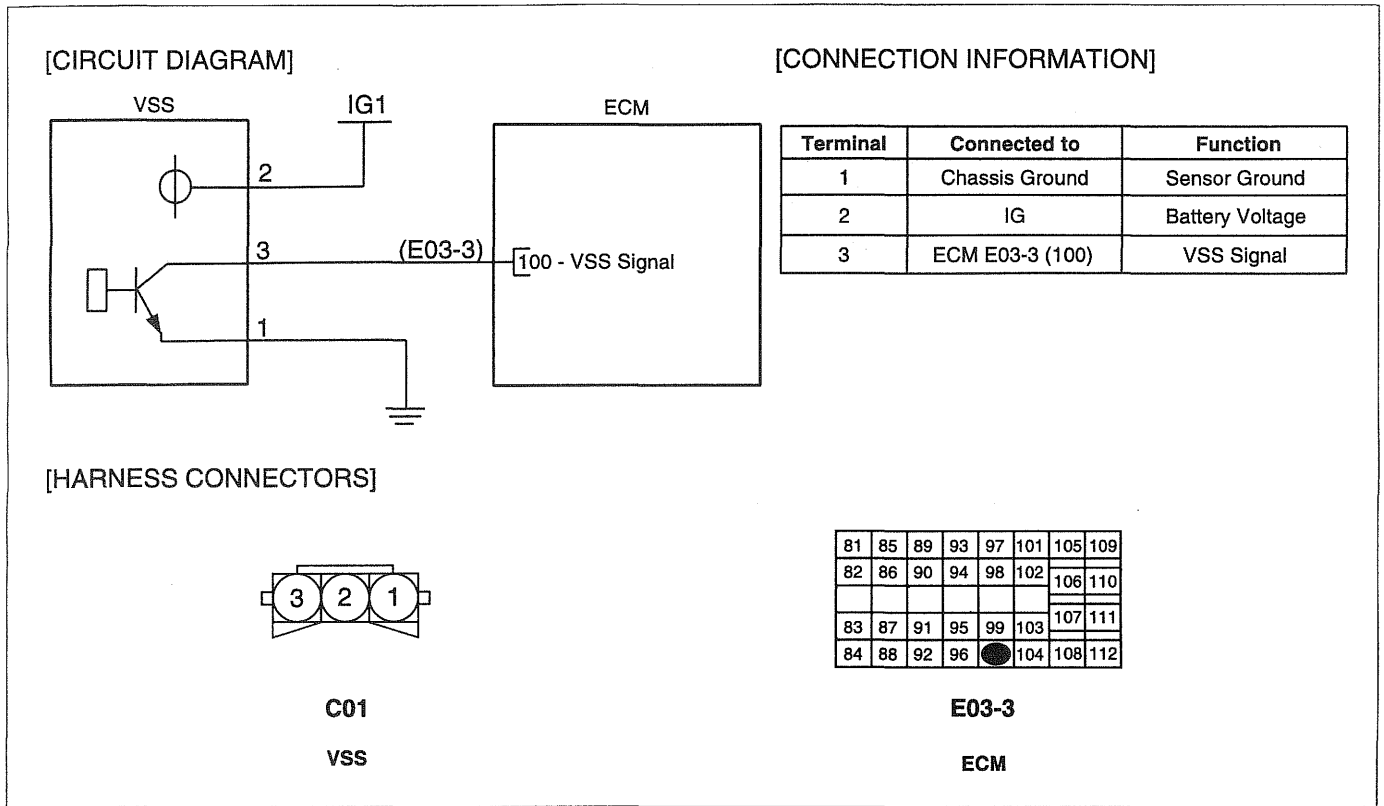

INSPECTION PROCEDURE

1. CHECK VSS AND ECM CONNECTORS

1. Thoroughly check connectors for looseness, poor connection, bending, corrosion, contamination, deterioration, or damage.
 - Refer to "CONNECTOR INSPECTION PROCEDURE" in BASIC INSPECTION PROCEDURE.

Are all connectors good?

Yes	No	Repair or replace it.
------------	----	-----------------------

2. CHECK POWER TO VSS

1. Turn ignition switch to OFF and disconnect VSS connector.
2. Turn ignition switch to ON.
3. Measure voltage in harness between terminal 2 of VSS harness connector and chassis ground.
 - **Specification: approximately B+**

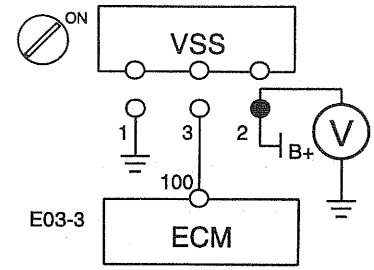

Is(Are) voltage(s) within specification?

Yes	No	Repair open or short circuit in harness.
------------	----	--

3. CHECK FOR OPEN IN HARNESS

1. Turn ignition switch to OFF, and then disconnect ECM and VSS connector.
2. Measure resistance between terminal 3 of VSS harness connector and terminal E03-3(100) of ECM harness connector.
 - **Specification: below 1Ω**

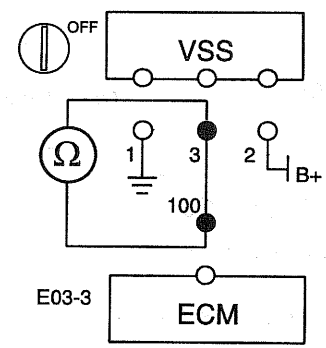

Is(Are) resistance(s) within specification?

Yes	No	Repair open circuit in harness.
------------	----	---------------------------------

4. CHECK FOR SHORT TO GROUND IN HARNESS

1. Turn ignition switch to OFF, and then disconnect ECM and VSS connector.
2. Measure resistance between terminal 3 of VSS harness connector and chassis ground.
3. Measure resistance between terminal 3 and 1 of VSS harness connector.
 - **Specification: below 1Ω**

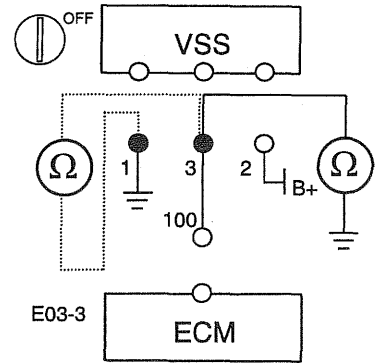

Is(Are) resistance(s) within specification?

Yes

No	Repair short or short to chassis ground in harness.
----	---

5. CHECK FOR SHORT TO POWER IN HARNESS

1. Turn ignition switch to OFF, and then disconnect ECM and VSS connector.
2. Turn ignition switch to ON.
3. Measure voltage between terminal 3 of VSS harness connector and chassis ground.
 - **Specification: below 0.5V**

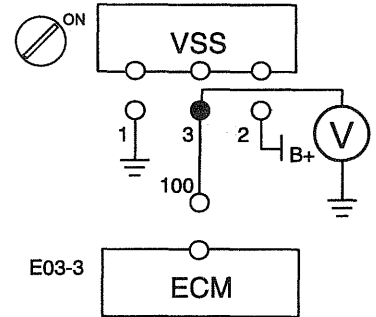

Is(Are) voltage(s) within specification?

Yes

No	Repair short to power in harness.
----	-----------------------------------

6. CHECK VSS

1. Replace the VSS with a new one, and then monitor the vehicle again using a Hi-Scan (Pro).

Is this problem fixed?

Yes

No	Replace the VSS.
----	------------------

Proceed with "ECM PROBLEM INSPECTION PROCEDURE" in BASIC INSPECTION PROCEDURE.

DTC DETECTING CONDITION ECD3F5BE

DTC	P1543	Brake Switch Signal Fault
CC-CODE	03	Short to battery line in brake switch 1 circuit
	02	Short to ground in brake switch 1 circuit
	0a	Short to battery line in brake switch 2 circuit
	0b	Short to ground in brake switch 2 circuit
	0c	Barke 1/2 signal incoherent

DESCRIPTION

Brake has an energy-absorbing mechanism that converts vehicle movement into heat to stop rotating wheels. Braking system is designed to reduce the speed and stop moving vehicle. The driver exerts a force on a brake pedal and

the force on the brake pedal pressurizes brake fluid in a master cylinder. This hydraulic force is transferred through steel lines to a wheel cylinder at each wheel. Hydraulic pressure to each wheel cylinder is used to force friction materials against the brake drum. The ECM senses the state of brake operating through brake switch.

DTC DETECTING CONDITION

CC-CODE	Detecting Condition	Suspect Area
02	• Short to battery line in brake switch 1 circuit	<ul style="list-style-type: none"> • Open or short in Brake Switch circuit • Brake Switch • Brake Pedal • ECM
03	• Short to ground in brake switch 1 circuit	
0a	• Short to battery line in brake switch 2 circuit	
0b	• Short to ground in brake switch 2 circuit	
0c	• Incoherent brake switch 1/2 signal	

[SCHEMATIC DIAGRAM]

[CIRCUIT DIAGRAM]

[CONNECTION INFORMATION]

Terminal	Connected to	Function
1	ECM E03-1 (16)	Brake Switch 1
	STOP Light	-
2	Battery	Battery Voltage
3	ECM E03-3 (86)	Brake Switch 2
4	Chassis Ground	Ground

[HARNESS CONNECTORS]

2	1
4	3

M11
BRAKE SWITCH

1	5	9	13	17	21	25	29
2	6	10	14	18	22	26	30
3	7	11	15	19	23	27	31
4	8	12	20	24	28	32	

E03-1

81	85	89	93	97	101	105	109
82	90	94	98	102	106	110	
83	87	91	95	99	103	107	111
84	88	92	96	100	104	108	112

E03-3

ECM

INSPECTION PROCEDURE

1. CHECK BRAKE SWITCH AND ECM CONNECTORS

1. Thoroughly check connectors for looseness, poor connection, bending, corrosion, contamination, deterioration, or damage.
 - Refer to "CONNECTOR INSPECTION PROCEDURE" in BASIC INSPECTION PROCEDURE.

Are all connectors good?

Yes

No	Repair or replace it.
----	-----------------------

2. CHECK FOR OPEN IN HARNESS

1. Turn ignition switch to OFF, and then disconnect ECM and brake switch connector.
2. Measure resistance between terminal 1 of brake switch harness connector and terminal E03-1(16) of ECM harness connector.
3. Measure resistance between terminal 3 of brake switch harness connector and terminal E03-3(86) of ECM harness connector.
 - **Specification: below 1Ω**

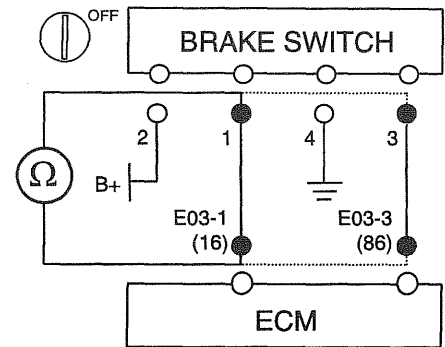

Is(Are) resistance(s) within specification?

Yes

No	Repair open circuit in harness.
----	---------------------------------

3. CHECK FOR SHORT TO GROUND IN HARNESS

1. Turn ignition switch to OFF, and then disconnect ECM and brake switch connector.
2. Measure resistance between terminal 1 of brake switch harness connector and chassis ground.
3. Measure resistance between terminal 3 of brake switch harness connector and chassis ground.
 - **Specification: infinite**

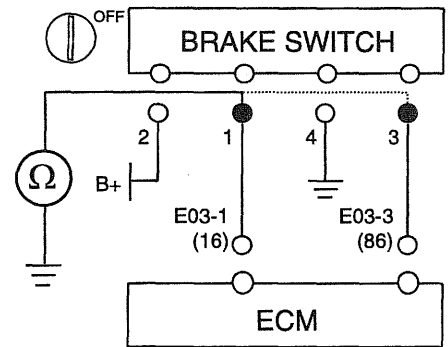

Is(Are) resistance(s) within specification?

Yes

No	Repair short or short to chassis ground in harness.
----	---

4. CHECK FOR SHORT TO POWER IN HARNESS

1. Turn ignition switch to OFF, and then disconnect ECM and brake switch connector.
2. Turn ignition switch to ON.
3. Measure voltage between terminal 1 of brake switch harness connector and chassis ground.
4. Measure voltage between terminal 3 of brake switch harness connector and chassis ground.
 - **Specification: below 0.5V**

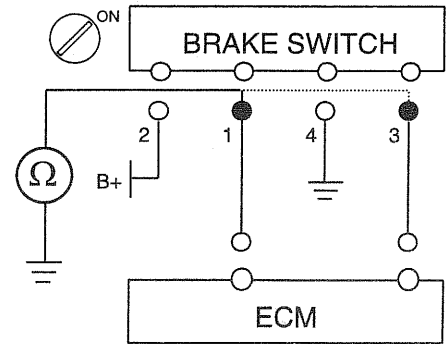

Is(Are) voltage(s) within specification?

Yes

No	Repair short to power in harness.
----	-----------------------------------

5. CHECK BRAKE SWITCH

1. Turn ignition switch OFF and check resistance of brake switch.
 - In case the brake pedal is released
 - Between the terminals 1 and 2 of brake S/W connector : infinite
 - Between the terminals 3 and 4 of brake S/W connector : below 1Ω
 - In case the brake pedal is depressed
 - Between the terminals 1 and 2 of brake S/W connector : below 1Ω
 - Between the terminals 3 and 4 of brake S/W connector : infinite

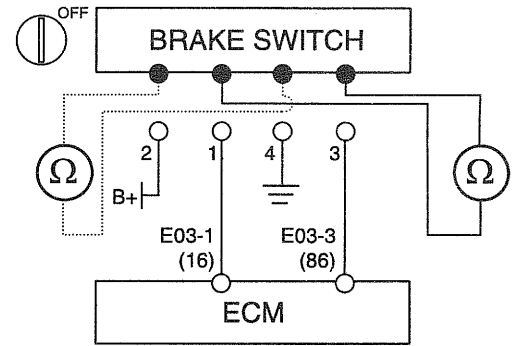

Is resistance within specification?

Yes

No	Replace the brake switch.
----	---------------------------

6. CHECK BRAKE PEDAL

1. Inspect operation condition and free-play of brake pedal.
 - Refer to the group "BR" in this Shop Manual.

Does the brake pedal have normal condition?

Yes

No	Replace the brake pedal.
----	--------------------------

Proceed with "ECM PROBLEM INSPECTION PROCEDURE" in BASIC INSPECTION PROCEDURE.

TROUBLESHOOTING FOR DTC E59F60B6

DTC	P1608	ECM Fault
CC-CODE	81	ECM internal fault
	82	ECM internal fault
	82	ECM internal fault
	82	ECM internal fault

DTC DETECTING CONDITION

CC-CODE	Detecting Condition	Suspect Area
81	<ul style="list-style-type: none"> Digital/Analog converter fault 	<ul style="list-style-type: none"> ECM
82		

INSPECTION PROCEDURE

<ul style="list-style-type: none"> Relace the ECM
--

TROUBLESHOOTING FOR DTC E5EF0BC6

DTC	P1610	Sensor External Voltage Fault
CC-CODE	08	Sensor supply voltage too low
	09	Sensor supply voltage too high

DTC DETECTING CONDITION

CC-CODE	Detecting Condition	Suspect Area
08	• Sensor reference voltage < 4.8V	• Short to battery line or ground in MAFS/APS1/RPS/CMPS supply line
09	• Sensor reference voltage > 5.2V	

[SCHEMATIC DIAGRAM] <1> MASS AIR FLOW SENSOR (MAFS)

[CIRCUIT DIAGRAM]

[CONNECTION INFORMATION]

Terminal	Connected to	Function
1	ECM E03-2 (78)	MAFS Signal
2	ECM E03-2 (77)	Reference Voltage
3	ECM E03-2 (79)	Sensor Ground
4	Main Relay	Battery Voltage
5	ECM E03-2 (42)	IATS Signal

[HARNESS CONNECTORS]

E17
MAFS & IATS

33	37	41	45	49	53	57	61	65	69	73	●
34	38	●	46	50	54	58	62	66	70	74	●
35	39	43	47	51	55	59	63	67	71	75	●
36	40	44	48	52	56	60	64	68	72	76	80

E03-2
ECM

[SCHEMATIC DIAGRAM] <2> ACCELERATOR POSITION SENSOR (APS) 1

[CIRCUIT DIAGRAM]

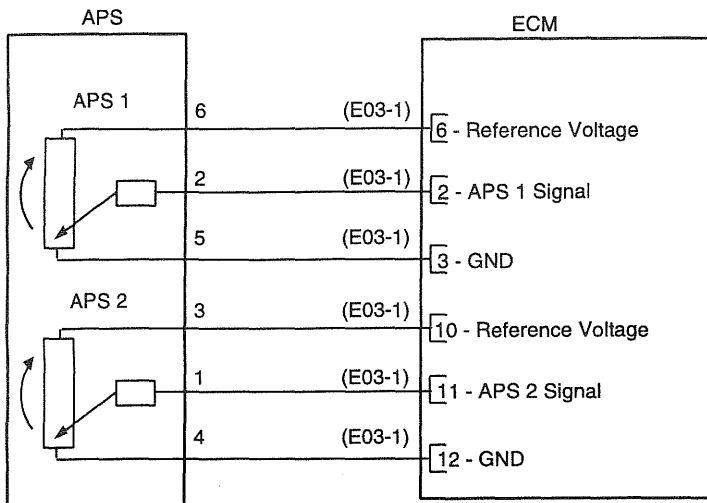

[CONNECTION INFORMATION]

Terminal	Connected to	Function
1	ECM E03-1 (11)	APS 2 Signal
2	ECM E03-1 (2)	APS 1 Signal
3	ECM E03-1 (10)	Reference Voltage
4	ECM E03-1 (12)	Sensor Ground
5	ECM E03-1 (3)	Sensor Ground
6	ECM E03-1 (6)	Reference Voltage

[HARNESS CONNECTORS]

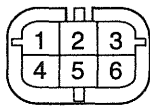

M07

ECTS

1	5	9	13	17	21	25	29
●	●	●	14	18	22	26	30
●	7	●	15	19	23	27	31
4	8	●	16	20	24	28	32

E03-1

ECM

[SCHEMATIC DIAGRAM] <3> RAIL PRESSURE SENSOR (RPS)

[CIRCUIT DIAGRAM]

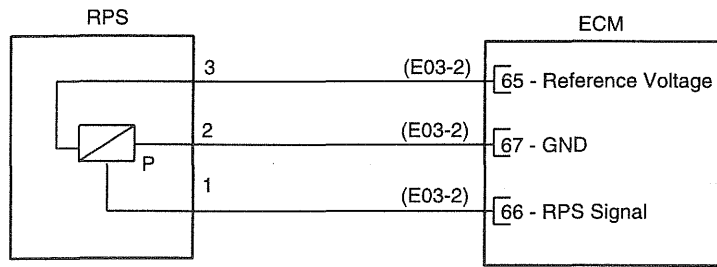

[CONNECTION INFORMATION]

Terminal	Connected to	Function
1	ECM E03-2 (66)	RPS Signal
2	ECM E03-2 (67)	Sensor Ground
3	ECM E03-2 (65)	Reference Voltage

[HARNESS CONNECTORS]

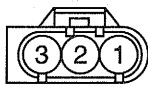

E88
RPS

33	37	41	45	49	53	57	61	65	69	73	77
34	38	42	46	50	54	58	62	66	70	74	78
35	39	43	47	51	55	59	63	67	71	75	79
36	40	44	48	52	56	60	64	68	72	76	80

E03-2
ECM

EWMF200S

[SCHEMATIC DIAGRAM] <4> CAMSHAFT POSITION SENSOR (CMPS)

[CIRCUIT DIAGRAM]

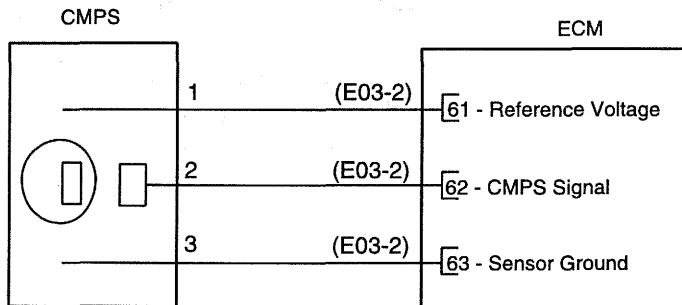

[CONNECTION INFORMATION]

Terminal	Connected to	Function
1	ECM E03-2 (61)	Reference Voltage
2	ECM E03-2 (62)	CMPS Signal
3	ECM E03-2 (63)	Sensor Ground

[HARNESS CONNECTORS]

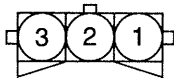

E90
CMPS

33	37	41	45	49	53	57	61	65	69	73	77
34	38	42	46	50	54	58	62	66	70	74	78
35	39	43	47	51	55	59	63	67	71	75	79
36	40	44	48	52	56	60	64	68	72	76	80

E03-2
ECM

EWMF201D

INSPECTION PROCEDURE

1. CHECK DTC

1. Connect the Hi-Scan (Pro) to the Data Link Connector (DLC).
2. Turn ignition switch to ON and check that any other DTC(s) is (are) detected.

Is(Are) any DTC(s) related to MAFS, APS 1, RPS or CMPS also set?

NO

YES	Do all repairs associated with those codes before proceeding with this procedure.
-----	---

2. CHECK MAFS, APS 1, RPS, CMPS AND ECM CONNECTORS

1. Thoroughly check connectors for looseness, poor connection, bending, corrosion, contamination, deterioration, or damage.
 - Refer to "CONNECTOR INSPECTION PROCEDURE" in BASIC INSPECTION PROCEDURE.

Are all connectors good?

Yes

No	Repair or replace it.
----	-----------------------

3-1. CHECK FOR SHORT TO GROUND IN HARNESS (MAFS)

1. Turn ignition switch to OFF, and then disconnect ECM and MAFS connector.
2. Measure resistance between terminal 2 of MAFS harness connector and chassis ground.
3. Measure resistance between terminal 2 and 3 of MAFS harness connector.
 - **Specification: infinite**

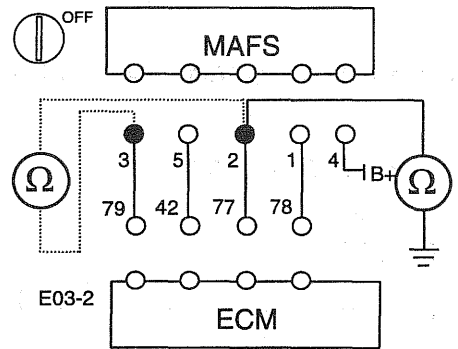

Is(Are) resistance(s) within specification?

Yes

No	Repair short or short to chassis ground in harness.
----	---

3-2. CHECK FOR SHORT TO GROUND IN HARNESS (APS 1)

1. Turn ignition switch to OFF, and then disconnect ECM and APS connector.
2. Measure resistance between terminal 6 of APS harness connector and chassis ground.
3. Measure resistance between terminal 6 and 5 of APS harness connector.
 - **Specification: infinite**

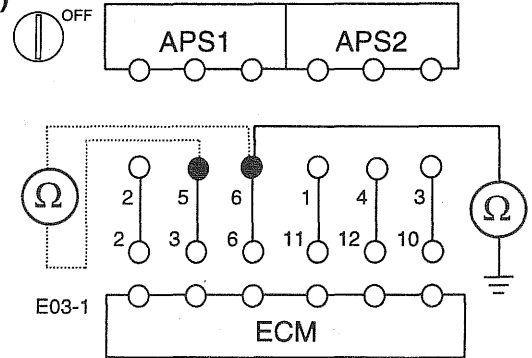

Is(Are) resistance(s) within specification?

Yes		No	Repair short or short to chassis ground in harness.
-----	--	----	---

3-3. CHECK FOR SHORT TO GROUND IN HARNESS (RPS)

1. Turn ignition switch to OFF, and then disconnect ECM and RPS connector.
2. Measure resistance between terminal 3 of RPS harness connector and chassis ground.
3. Measure resistance between terminal 3 and 2 of RPS harness connector.
 - **Specification: infinite**

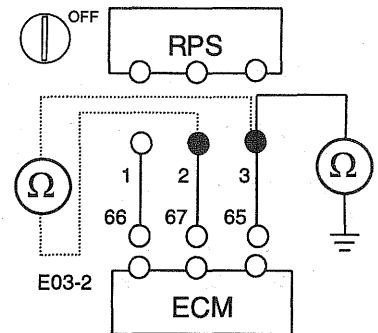

Is(Are) resistance(s) within specification?

Yes		No	Repair short or short to chassis ground in harness.
-----	--	----	---

3-4. CHECK FOR SHORT TO GROUND IN HARNESS (CMPS)

1. Turn ignition switch to OFF, and then disconnect ECM and CMPS connector.
2. Measure resistance between terminal 1 of CMPS harness connector and chassis ground.
3. Measure resistance between terminal 1 and 3 of CMPS harness connector.
 - **Specification: infinite**

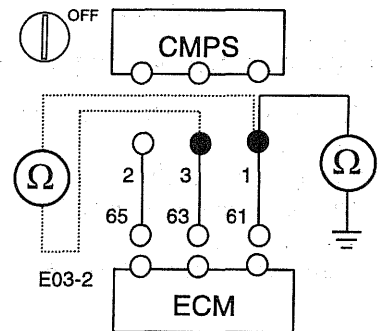

Is(Are) resistance(s) within specification?

Yes

No Repair short or short to chassis ground in harness.

4-1. CHECK FOR SHORT TO POWER IN HARNESS (MAFS)

1. Turn ignition switch to OFF, and then disconnect ECM and MAFS connector.
2. Turn ignition switch to ON.
3. Measure voltage between terminal 2 of MAFS harness connector and chassis ground.
 - **Specification: below 0.5V**

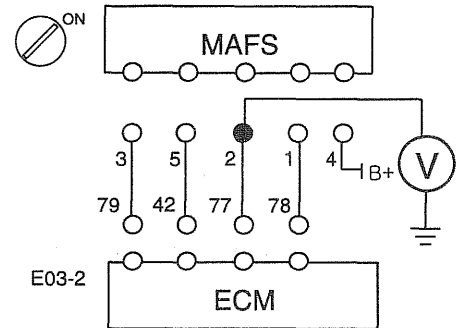

Is(Are) voltage(s) within specification?

Yes

No Repair short to power in harness.

4-2. CHECK FOR SHORT TO POWER IN HARNESS (APS 1)

1. Turn ignition switch to OFF, and then disconnect ECM and APS connector.
2. Turn ignition switch to ON.
3. Measure voltage between terminal 6 of APS harness connector and chassis ground.
 - **Specification: below 0.5V**

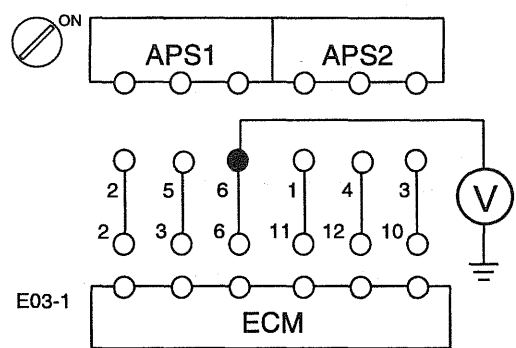

Is(Are) voltage(s) within specification?

Yes

No Repair short to power in harness.

4-3. CHECK FOR SHORT TO POWER IN HARNESS (RPS)

1. Turn ignition switch to OFF, and then disconnect ECM and RPS connector.
2. Turn ignition switch to ON.
3. Measure voltage between terminal 3 of RPS harness connector and chassis ground.
 - **Specification: below 0.5V**

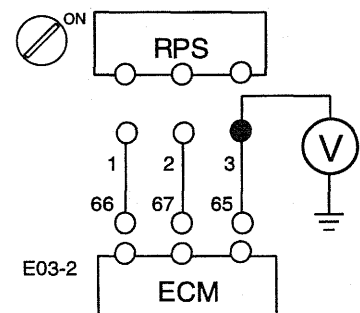

Is(Are) voltage(s) within specification?

Yes

No	Repair open circuit in harness.
----	---------------------------------

4-4. CHECK FOR SHORT TO POWER IN HARNESS

1. Turn ignition switch to OFF, and then disconnect ECM and CMPS connector.
2. Turn ignition switch to ON.
3. Measure voltage between terminal 1 of CMPS harness connector and chassis ground.
 - **Specification: below 0.5V**

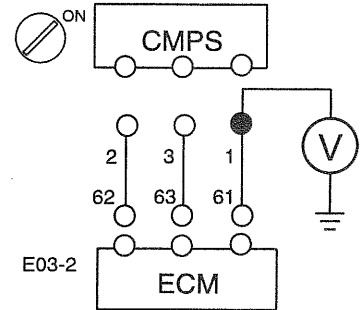

Is(Are) voltage(s) within specification?"

Yes

No	Repair short to power in harness.
----	-----------------------------------

Proceed with "ECM PROBLEM INSPECTION PROCEDURE" in BASIC INSPECTION PROCEDURE.

TROUBLESHOOTING FOR DTC EF5AE540

DTC	P1614	ECM Programming Error
CC-CODE	85	ECM internal fault
	83	ECM internal fault
	8b	ECM internal fault
	88	ECM internal fault
	87	ECM internal fault
	8a	ECM internal fault
	8c	ECM internal fault
	8a	ECM internal fault

DTC DETECTING CONDITION

CC-CODE	Detecting Condition	Suspect Area
85	<ul style="list-style-type: none"> • Impossibility of reading on the EEPROM 	<ul style="list-style-type: none"> • Injector control line • ECM
83	<ul style="list-style-type: none"> • Impossibility of writing on the EEPROM 	
8b	<ul style="list-style-type: none"> • Electrical interference on the injector control line 	
88	<ul style="list-style-type: none"> • Fault in the calibration file or in the software. 	
87	<ul style="list-style-type: none"> • One or more cells are found to be defective during the testing of the cells of the entire RAM used by the ECM • Incorrect injector specific data 	
8a	<ul style="list-style-type: none"> • Watchdog operation fault 	
8c		
8a		

INSPECTION PROCEDURE

[CASE 1] CC-CODE 8a, 8c, 83, 85, 87, 88

- Relace the ECM

EWMF213D

[CASE 2] CC-CODE 8b

1. VERIFICATION OF INJECTOR SPECIFIC DATA

1. Connect the Hi-Scan (Pro) to the Data Link Connector (DLC).
2. Compare the injector specific data memorized in ECM memory with the one written on injector.

Are the two data same?

NO

YES	Input the injector specific data using Hi-Scan (Pro).
-----	---

2. CHECK INJECTOR CONTROL LINE

1. Inspect the wiring harness between the injector and ECM.

Does this wiring harness have normal condition?"

Yes

No	Repair or replace the wiring harness.
----	---------------------------------------

Proceed with "ECM PROBLEM INSPECTION PROCEDURE" in BASIC INSPECTION PROCEDURE.

EWMF203I

TROUBLESHOOTING FOR DTC E6981CE4

DTC	P1620	A/C Relay Circuit Malfunction
CC-CODE	0a	Open circuit or short circuit to ground
	03	Short circuit to battery line

DTC DETECTING CONDITION

CC-CODE	Detecting Condition	Suspect Area
0a	<ul style="list-style-type: none"> Open or short to ground in A/C relay circuit 	<ul style="list-style-type: none"> Open or short in A/C Relay circuit A/C Relay ECM
03	<ul style="list-style-type: none"> Short to battery line in A/C relay circuit 	

[SCHEMATIC DIAGRAM]

[CIRCUIT DIAGRAM]

[CONNECTION INFORMATION]

Terminal	Connected to	Function
1	Battery	Battery Voltage
2	Compressor	Compressor Power Supply
3	ECM E03-3 (105)	A/C Relay Control
4	-	-
5	Main Relay	Battery Voltage

[HARNESS CONNECTORS]

E121
A/C RELAY

81	85	89	93	97	101	105	109
82	86	90	94	98	102	106	110
						107	111
83	87	91	95	99	103		
84	88	92	96	100	104	108	112

E03-3
ECM

INSPECTION PROCEDURE

1. CHECK A/C RELAY AND ECM CONNECTORS

1. Thoroughly check connectors for looseness, poor connection, bending, corrosion, contamination, deterioration, or damage.
 - Refer to "CONNECTOR INSPECTION PROCEDURE" in BASIC INSPECTION PROCEDURE.

Are all connectors good?

NO	YES	Repair or replace it.
-----------	-----	-----------------------

2. CHECK A/C RELAY

1. Turn ignition switch to OFF and remove the A/C relay.
2. Apply power to the terminal 5 and ground terminal 3 of A/C relay.
3. Check if A/C relay works well.
(If A/C relay works normally, a "click" sound can be heard).

Does the A/C relay operate normally?

Yes	No	Replace the glow plug relay
------------	----	-----------------------------

3. CHECK POWER TO A/C RELAY

1. Turn ignition switch to OFF and disconnect A/C relay connector.
2. Turn ignition switch to ON
3. Measure voltage in harness between terminal 1 of A/C relay harness connector and chassis ground.
4. Measure voltage in harness between terminal 5 of A/C relay harness connector and chassis ground.
 - **Specification: approximately B+**

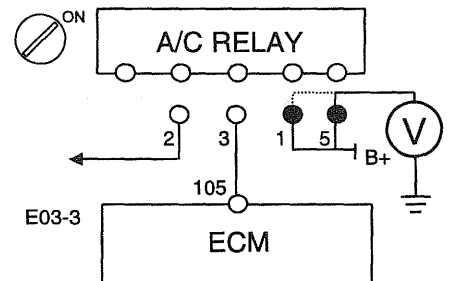

Is(Are) voltage(s) within specification?

Yes	No	Repair open or short circuit in harness.
------------	----	--

4. CHECK FOR OPEN IN HARNESS

1. Turn ignition switch to OFF, and then disconnect ECM and A/C relay connector.
2. Measure resistance between terminal 3 of A/C relay harness connector and terminal E03-3(105) of ECM harness connector.
 - **Specification: below 1Ω**

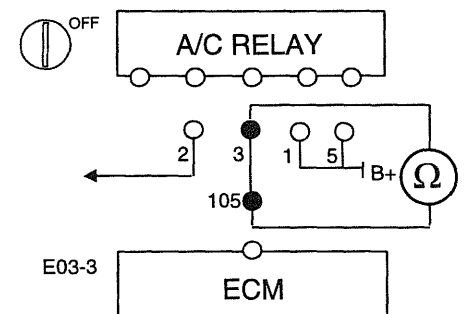

Is(Are) resistance(s) within specification?

Yes

No Repair open circuit in harness.

5. CHECK FOR SHORT TO GROUND IN HARNESS

1. Turn ignition switch to OFF, and then disconnect ECM and A/C relay connector.
2. Measure resistance between terminal 3 of A/C relay harness connector and chassis ground.
 - **Specification: infinite**

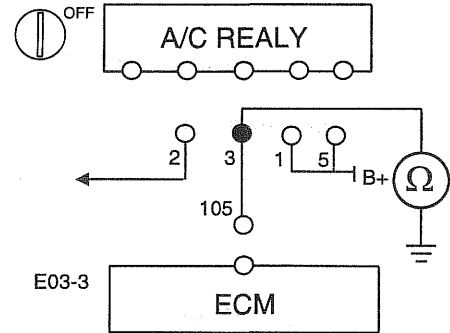

Is(Are) resistance(s) within specification?

Yes

No Repair short or short to chassis ground in harness.

6. CHECK FOR SHORT TO POWER IN HARNESS

1. Turn ignition switch to OFF, and then disconnect ECM and A/C relay connector.
2. Turn ignition switch to ON.
3. Measure voltage between terminal 3 of A/C relay harness connector and chassis ground.
 - **Specification: below 0.5V**

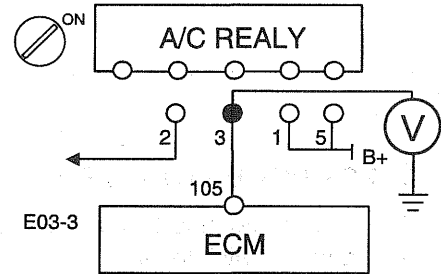

Is(Are) voltage(s) within specification?

Yes

No Repair short to power in harness.

Proceed with "ECM PROBLEM INSPECTION PROCEDURE" in BASIC INSPECTION PROCEDURE.

TROUBLESHOOTING FOR DTC EEC4BFF4

DTC	P1640	Main Relay Circuit Malfunction
CC-CODE	0a	Open circuit or short circuit to ground
	0b	Short circuit to battery line

DESCRIPTION

The charging system includes a battery, generator with a built in regulator, the charging indicator light, and connecting wiring. The generator uses diodes to rectify alternating current (AC) to direct current (DC). The ECM provides ground to one side of coil of main relay and the other side

is connected to battery. The ECM monitors battery voltage and the voltage after main relay.

DTC DETECTING CONDITION

CC-CODE	Detecting Condition	Suspect Area
0a	• Open or short to ground in main relay circuit	<ul style="list-style-type: none"> • Open or short in Main Relay circuit • Main Relay • ECM
0b	• Short to battery line in main relay circuit	

[SCHEMATIC DIAGRAM]

[CIRCUIT DIAGRAM]

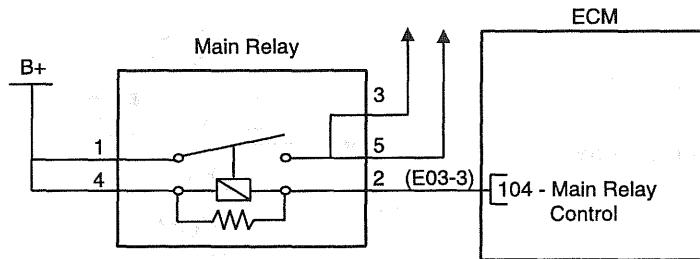

[CONNECTION INFORMATION]

Terminal	Connected to	Function
1	Battery	Battery Voltage
2	ECM E03-3 (104)	Main Relay Control
3	-	-
4	Battery	Battery Voltage
5	-	-

[HARNESS CONNECTORS]

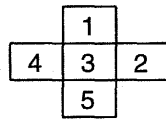

E113

MAIN RELAY

81	85	89	93	97	101	105	109
82	86	90	94	98	102	106	110
						107	111
83	87	91	95	99	103		
84	88	92	96	100	104	108	112

E03-3

ECM

INSPECTION PROCEDURE

1. CHECK MAIN RELAY AND ECM CONNECTORS

1. Thoroughly check connectors for looseness, poor connection, bending, corrosion, contamination, deterioration, or damage.
 - Refer to "CONNECTOR INSPECTION PROCEDURE" in BASIC INSPECTION PROCEDURE.

Are all connectors good?

YES		
	NO	Repair or replace it.

2. CHECK MAIN RELAY

1. Turn ignition switch to OFF and remove the main relay.
2. Apply power to the terminal 4 and ground terminal 2 of main relay.
3. Check if main relay works well.
 - (If main relay works normally, a "click" sound can be heard).
 - Refer to "CONNECTOR INSPECTION PROCEDURE" in BASIC INSPECTION PROCEDURE.

Does the main relay operate normally?

Yes		
	No	Replace the glow plug relay

3. CHECK POWER TO MAIN RELAY

1. Turn ignition switch to OFF and disconnect main relay connector.
2. Turn ignition switch to ON.
3. Measure voltage in harness between terminal 4 of main relay harness connector and chassis ground.
4. Measure voltage in harness between terminal 1 of main relay harness connector and chassis ground.
 - Specification: approximately B+

Is(Are) voltage(s) within specification?

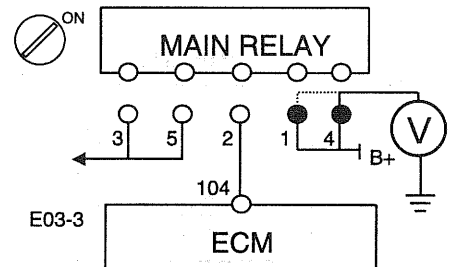

Yes		
	No	Replace the glow plug relay

4. CHECK FOR OPEN IN HARNESS

1. Turn ignition switch to OFF, and then disconnect ECM and main relay connector.
2. Measure resistance between terminal 2 of main relay harness connector and terminal E03-3(104) of ECM harness connector.
 - Specification: below 1Ω

Is(Are) resistance(s) within specification?

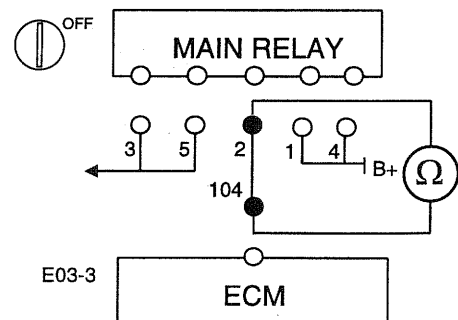

Yes

No Repair open or short circuit in harness.

5. CHECK FOR SHORT TO GROUND IN HARNESS

1. Turn ignition switch to OFF, and then disconnect ECM and main relay connector.
2. Measure resistance between terminal 2 of main relay harness connector and chassis ground.
 - **Specification: infinite**

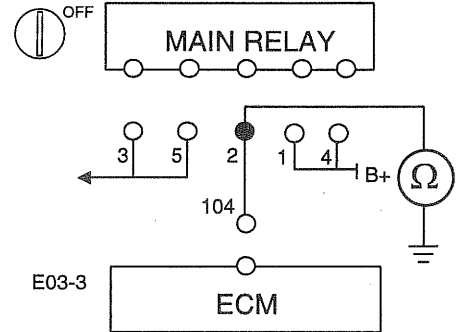

Is(Are) resistance(s) within specification?

Yes

No Repair open circuit in harness.

6. CHECK FOR SHORT TO POWER IN HARNESS

1. Turn ignition switch to OFF, and then disconnect ECM and main relay connector.
2. Turn ignition switch to ON.
3. Measure voltage between terminal 1 of main relay harness connector and chassis ground.
 - **Specification: below 0.5V**

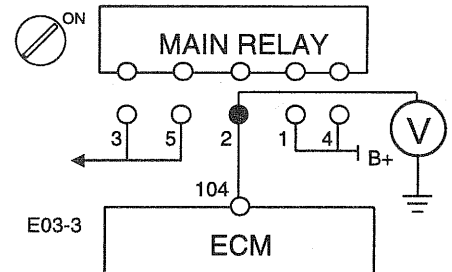

Is(Are) voltage(s) within specification?

Yes

No Repair short to power in harness.

Proceed with "ECM PROBLEM INSPECTION PROCEDURE" in BASIC INSPECTION PROCEDURE.

TROUBLESHOOTING FOR DTC E0FE59FA

DTC	P1674	A/C Fan Relay Circuit Malfunction
CC-CODE	0a	Open circuit or short circuit to ground
	03	Short circuit to battery line

DTC DETECTING CONDITION

CC-CODE	Detecting Condition	Suspect Area
0a	• Open or short to ground in A/C fan relay circuit	<ul style="list-style-type: none"> • Open or short in A/C Fan Relay circuit • A/C Fan Relay • ECM
03	• Short to battery line in A/C fan relay circuit	

[SCHEMATIC DIAGRAM]

[CIRCUIT DIAGRAM]

The circuit diagram shows two A/C fan relays. A/C Fan Relay #2 is controlled by the A/C Control Module (Auto A/C) and a Thermostatic Switch (Manual A/C). Its terminals are: 1 (B+), 2 (Chassis Ground), 4 (Control), and 5 (Radiator Fan Motor). A/C Fan Relay #1 is controlled by the ECM (E03-3) at terminal 84. Its terminals are: 1 (B+), 4 (Main Relay), 2 (ECM E03-3 (84)), and 5 (Condenser Fan Motor). Both relays have a common terminal 3 connected to ground. The Main Relay is also connected to the B+ line.

[CONNECTION INFORMATION]

Terminal	Connected to	Function
1	Battery	Battery Voltage
2	Chassis Ground	Ground
3	-	-
4	(Auto A/C) A/C Control Module (Manual A/C) Thermostatic Switch	A/C Fan Relay #2 Control
5	Radiator Fan Motor	Motor Power Supply

Terminal	Connected to	Function
1	Battery	Battery Voltage
2	ECM E03-3 (84)	A/C Fan Relay #1 Control
3	-	-
4	Main Relay	Battery Voltage
5	Condenser Fan Motor	Motor Power Supply

[HARNES CONNECTORS]

E110
A/C FAN RELAY #1

E111
A/C FAN RELAY #2

81	85	89	93	97	101	105	109
82	86	90	94	98	102	106	110
						107	111
83	87	91	95	99	103		
● 88	92	96	100	104	108	112	

E03-3
ECM

INSPECTION PROCEDURE

1. CHECK A/C FAN RELAY #1 AND ECM CONNECTORS

1. Thoroughly check connectors for looseness, poor connection, bending, corrosion, contamination, deterioration, or damage.
 - Refer to "CONNECTOR INSPECTION PROCEDURE" in BASIC INSPECTION PROCEDURE.

Are all connectors good?

Yes	No	Repair or replace it.
------------	----	-----------------------

2. CHECK A/C FAN RELAY #1

1. Turn ignition switch to OFF and remove the A/C fan relay #1.
2. Apply power to the terminal 3 and ground terminal 5 of A/C fan relay #1.
3. Check if A/C fan relay #1 works well.
 - (If A/C fan relay #1 works normally, a "click" sound can be heard).

Does the A/C fan relay #1 operate normally?

Yes	No	Replace the glow plug relay
------------	----	-----------------------------

3. CHECK POWER TO A/C FAN RELAY #1

1. Turn ignition switch to OFF and disconnect A/C fan relay #1 connector.
2. Turn ignition switch to ON.
3. Measure voltage in harness between terminal 1 of A/C fan relay #1 harness connector and chassis ground.
4. Measure voltage in harness between terminal 4 of A/C fan relay #1 harness connector and chassis ground.
 - **Specification: approximately B+**

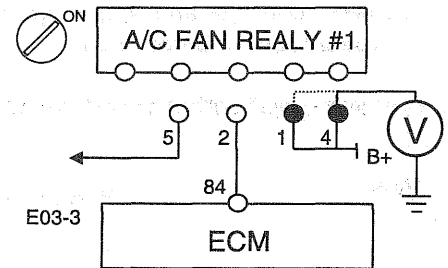

Is(Are) voltage(s) within specification?

Yes	No	Repair open or short circuit in harness.
------------	----	--

4. CHECK FOR OPEN IN HARNESS

1. Turn ignition switch to OFF, and then disconnect ECM and A/C fan relay #1 connector.
2. Measure resistance between terminal 2 of A/C fan relay #1 harness connector and terminal E03-3(84) of ECM harness connector.
 - **Specification: below 1Ω**

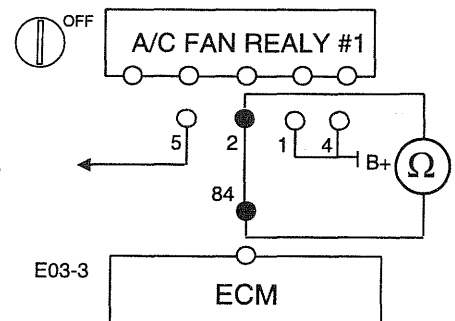

Is(Are) resistance(s) within specification?

Yes

No	Repair open circuit in harness.
----	---------------------------------

5. CHECK FOR SHORT TO GROUND IN HARNESS

1. Turn ignition switch to OFF, and then disconnect ECM and A/C fan relay #1 connector.
2. Measure resistance between terminal 2 of A/C fan relay #1 harness connector and chassis ground.
 - **Specification: infinite**

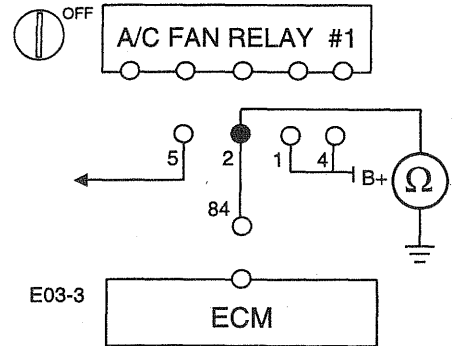

Is(Are) resistance(s) within specification?

Yes

No	Repair short or short to chassis ground in harness.
----	---

6. CHECK FOR SHORT TO POWER IN HARNESS

1. Turn ignition switch to OFF, and then disconnect ECM and A/C fan relay #1 connector.
2. Turn ignition switch to ON.
3. Measure voltage between terminal 2 of A/C fan relay #1 harness connector and chassis ground.
 - **Specification: below 0.5V**

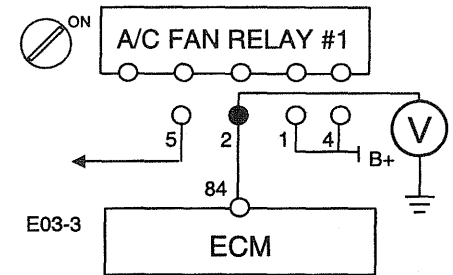

Is(Are) voltage(s) within specification?

Yes

No	Repair short to power in harness.
----	-----------------------------------

Proceed with "ECM PROBLEM INSPECTION PROCEDURE" in BASIC INSPECTION PROCEDURE.

TROUBLESHOOTING FOR DTC ED5C53BD

DTC	P1786	Tachometer Output Fault
CC-CODE	0a	Signal low (Short circuit to ground)
	03	Signal high (Short circuit to battery line)

DTC DETECTING CONDITION

CC-CODE	Detecting Condition	Suspect Area
0a	<ul style="list-style-type: none"> Open or short to ground in tachometer output circuit 	<ul style="list-style-type: none"> Open or short in Tachometer Output circuit ECM
03	<ul style="list-style-type: none"> Short to battery line in tachometer output circuit 	

[SCHEMATIC DIAGRAM]

[CIRCUIT DIAGRAM]

[CONNECTION INFORMATION]

Terminal	Connected to	Function
8	ECM E03-1 (26)	Engine Speed Output

[HARNESS CONNECTORS]

I03-1
CLUSTER

1	5	9	13	17	21	25	29
2	6	10	14	18	22	26	30
3	7	11	15	19	23	27	31
4	8	12	16	20	24	28	32

E03-1
ECM

INSPECTION PROCEDURE

1. CHECK CLUSTER AND ECM CONNECTORS

1. Thoroughly check connectors for looseness, poor connection, bending, corrosion, contamination, deterioration, or damage.
 - Refer to ""CONNECTOR INSPECTION PROCEDURE"" in BASIC INSPECTION PROCEDURE.

Are all connectors good?

Yes

No Repair or replace it.

2. CHECK FOR OPEN IN HARNESS

1. Turn ignition switch to OFF, and then disconnect ECM and cluster connector.
2. Measure resistance between terminal I03-1(8) of cluster harness connector and terminal E03-1(26) of ECM harness connector.
 - Specification: below 1Ω

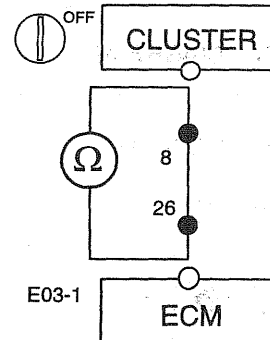

Is(Are) resistance(s) within specification?

Yes

No Repair open circuit in harness.

3. CHECK FOR SHORT TO GROUND IN HARNESS

1. Turn ignition switch to OFF, and then disconnect ECM and cluster connector.
2. Measure resistance between terminal I03-1(8) of cluster harness connector and chassis ground.
 - Specification: infinite

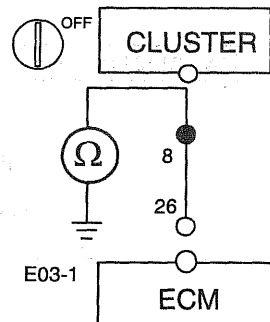

Is(Are) resistance(s) within specification?

Yes

No Repair short or short to chassis ground in harness.

4 . CHECK FOR SHORT TO POWER IN HARNESS

1. Turn ignition switch to OFF, and then disconnect ECM and cluster connector.
2. Turn ignition switch to ON.
3. Measure voltage between terminal I03-1(8) of cluster harness connector and chassis ground.
 - **Specification: below 0.5V**

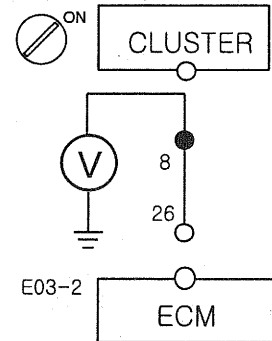

Is(Are) voltage(s) within specification?

Yes

No	Repair short to power in harness.
----	-----------------------------------

Proceed with "ECM PROBLEM INSPECTION PROCEDURE" in BASIC INSPECTION PROCEDURE.

TROUBLESHOOTING FOR DTC E61190DB

DTC	P2264	Water Sensor Circuit Malfunction
CC-CODE	0b	Permanent low level

DESCRIPTION

Water Sensor is located in the fuel filter assembly and senses water in fuel. When water is detected, the ECM turns the Indicator Lamp in cluster on.

DTC DETECTING CONDITION

CC-CODE	Detecting Condition	Suspect Area
0b	<ul style="list-style-type: none"> Open or short to ground in water sensor circuit 	<ul style="list-style-type: none"> Open or short in Water Sensor circuit Water Sensor ECM

[SCHEMATIC DIAGRAM]

[CIRCUIT DIAGRAM]

[CONNECTION INFORMATION]

Terminal	Connected to	Function
1	IG1	Battery Voltage
2	ECM E03-1 (15)	Water Sensor Signal
3	Chassis Ground	Sensor Ground

[HARNESS CONNECTORS]

WATER SENSOR (IN FUEL FILTER)

E03-1

ECM

INSPECTION PROCEDURE

1. CHECK WATER SENSOR AND ECM CONNECTORS

1. Thoroughly check connectors for looseness, poor connection, bending, corrosion, contamination, deterioration, or damage.
 - Refer to "CONNECTOR INSPECTION PROCEDURE" in BASIC INSPECTION PROCEDURE.

Are all connectors good?

Yes

No	Repair or replace it.
----	-----------------------

2. CHECK POWER TO WATER SENSOR

1. Turn ignition switch to OFF and disconnect water sensor connector.
2. Turn ignition switch to ON.
3. Measure voltage in harness between terminal 1 of water sensor harness connector and chassis ground.
 - Specification: approximately B+

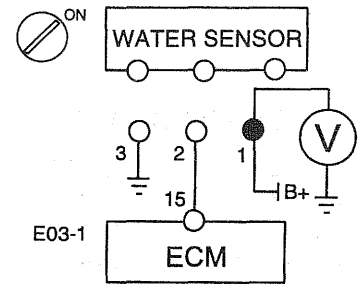

Is(Are) voltage(s) within specification?

Yes

No	Repair open or short circuit in harness.
----	--

3. CHECK FOR OPEN IN HARNESS

1. Turn ignition switch to OFF, and then disconnect ECM and water sensor connector.
2. Measure resistance between terminal 2 of water sensor harness connector and terminal E03-1(15) of ECM harness connector.
 - Specification: below 1Ω

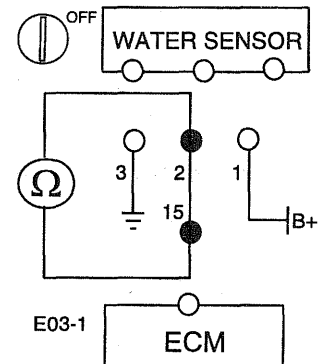

Is(Are) resistance(s) within specification?

Yes

No	Repair open circuit in harness.
----	---------------------------------

4 . CHECK FOR SHORT TO GROUND IN HARNESS

1. Turn ignition switch to OFF, and then disconnect ECM and water sensor connector.
2. Measure resistance between terminal 2 of water sensor harness connector and chassis ground.
 - **Specification: infinite**

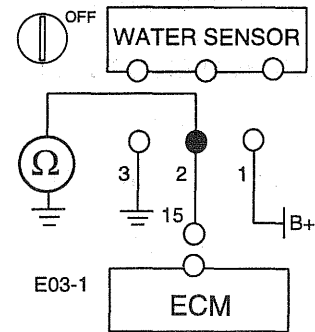

Is(Are) resistance(s) within specification?

Yes		No Repair short or short to chassis ground in harness.
------------	--	---

5 . CHECK FOR SHORT TO POWER IN HARNESS

1. Turn ignition switch to OFF, and then disconnect ECM and water sensor connector.
2. Turn ignition switch to ON.
3. Measure voltage between terminal 2 of water sensor harness connector and chassis ground.
 - **Specification: below 0.5V**

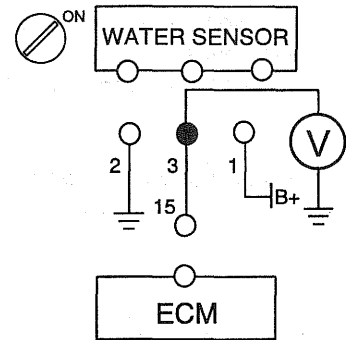

Is(Are) voltage(s) within specification?

Yes		No Repair short to power in harness.
------------	--	---

6 . CHECK WATER SENSOR

1. Replace the water sensor with a new one, and then monitor the vehicle again using a Hi-Scan (Pro).

Is this problem fixed?

Yes		No Replace the water sensor.
------------	--	---------------------------------

Proceed with "ECM PROBLEM INSPECTION PROCEDURE" in BASIC INSPECTION PROCEDURE.

TROUBLESHOOTING FOR DTC EEC2D86D

DTC	P2269	Water in Fuel Filter Indicator Lamp Circuit Malfunction
CC-CODE	0a	Signal low (Open circuit or short circuit to ground)
	03	Signal high (Short circuit to battery line)

DESCRIPTION

Water Sensor is located in the fuel filter assembly and senses water in fuel. When water is detected, the ECM turns the Indicator Lamp in cluster on.

DTC DETECTING CONDITION

CC-CODE	Detecting Condition	Suspect Area
0a	<ul style="list-style-type: none"> Open or short to ground in Water Indicator Lamp circuit 	<ul style="list-style-type: none"> Open or short in Water Indicator Lamp circuit Water Indicator Lamp ECM
03	<ul style="list-style-type: none"> Short to battery line in Water Indicator Lamp circuit 	

[SCHEMATIC DIAGRAM]

[CIRCUIT DIAGRAM]

WATER INDICATOR LAMP

ECM

38 - Water Indicator Lamp Control

(E03-2)

IG ON

[CONNECTION INFORMATION]

Terminal	Connected to	Function
A	ECM E03-2 (38)	Water Indicator Lamp Control
B	IG	Battery Voltage

NOTE
Refer to "ELECTRICAL TROUBLESHOOTING MANUAL" for the terminals A and B.

[HARNES CONNECTORS]

33	37	41	45	49	53	57	61	65	69	73	77
34		42	46	50	54	58	62	66	70	74	78
35	39										
		43	47	51	55	59	63	67	71	75	79
36	40	44	48	52	56	60	64	68	72	76	80

E03-2

ECM

INSPECTION PROCEDURE

1. CHECK WATER INDICATOR LAMP (CLUSTER) AND ECM CONNECTORS

1. Thoroughly check connectors for looseness, poor connection, bending, corrosion, contamination, deterioration, or damage.
 - Refer to "CONNECTOR INSPECTION PROCEDURE" in BASIC INSPECTION PROCEDURE.

Are all connectors good?

Yes	No	Repair or replace it.
-----	----	-----------------------

2. CHECK POWER TO WATER INDICATOR LAMP (CLUSTER)

1. Turn ignition switch to OFF and disconnect water indicator lamp(Cluster) connector.
2. Turn ignition switch to ON.
3. Measure voltage in harness between terminal B of water indicator lamp(Cluster) harness connector and chassis ground.
 - **Specification: approximately B+**

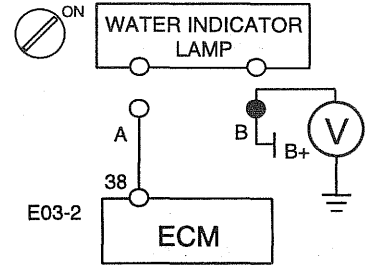

Is(Are) voltage(s) within specification?

Yes	No	Repair open or short circuit in harness.
-----	----	--

3. CHECK FOR OPEN IN HARNESS

1. Turn ignition switch to OFF, and then disconnect ECM and water indicator lamp(Cluster) connector.
2. Measure resistance between terminal A of water indicator lamp(Cluster) harness connector and terminal E03-2(38) of ECM harness connector.
 - **Specification: below 1Ω**

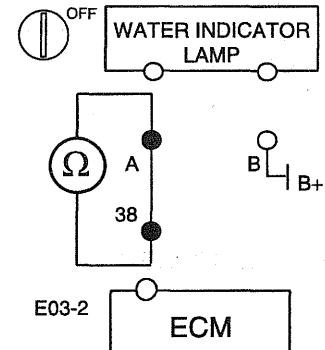

Is(Are) resistance(s) within specification?

Yes	No	Repair open circuit in harness.
-----	----	---------------------------------

4 . CHECK FOR SHORT TO GROUND IN HARNESS

1. Turn ignition switch to OFF, and then disconnect ECM and MIL(Cluster) connector.
2. Measure resistance between terminal A of MIL(Cluster) harness connector and chassis ground.
 - **Specification: infinite**

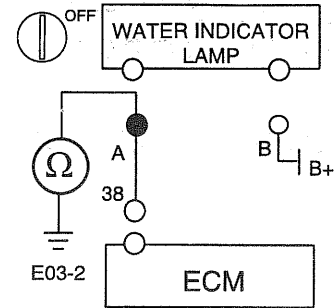

Is(Are) resistance(s) within specification?

Yes		
No		Repair short or short to chassis ground in harness.

5 . CHECK FOR SHORT TO POWER IN HARNESS

1. Turn ignition switch to OFF, and then disconnect ECM and MIL(Cluster) connector.
2. Turn ignition switch to ON.
3. Measure voltage between terminal A of MIL(Cluster) harness connector and chassis ground.
 - **Specification: below 0.5V**

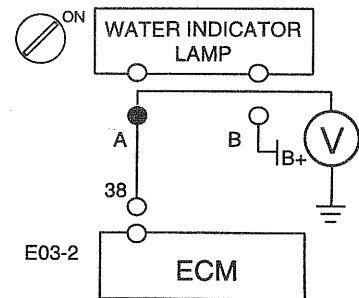

Is(Are) voltage(s) within specification?

Yes		
No		Repair short to power in harness.

6 . CHECK MIL(CLUSTER)

1. Inspect the MIL installed on the cluster.

Does the MIL have normal condition?

Yes		
No		Replace the MIL.

Proceed with "ECM PROBLEM INSPECTION PROCEDURE" in BASIC INSPECTION PROCEDURE.

FUEL DELIVERY SYSTEM-DIESEL

COMMON RAIL FUEL INJECTION SYSTEM EBFF6ADE

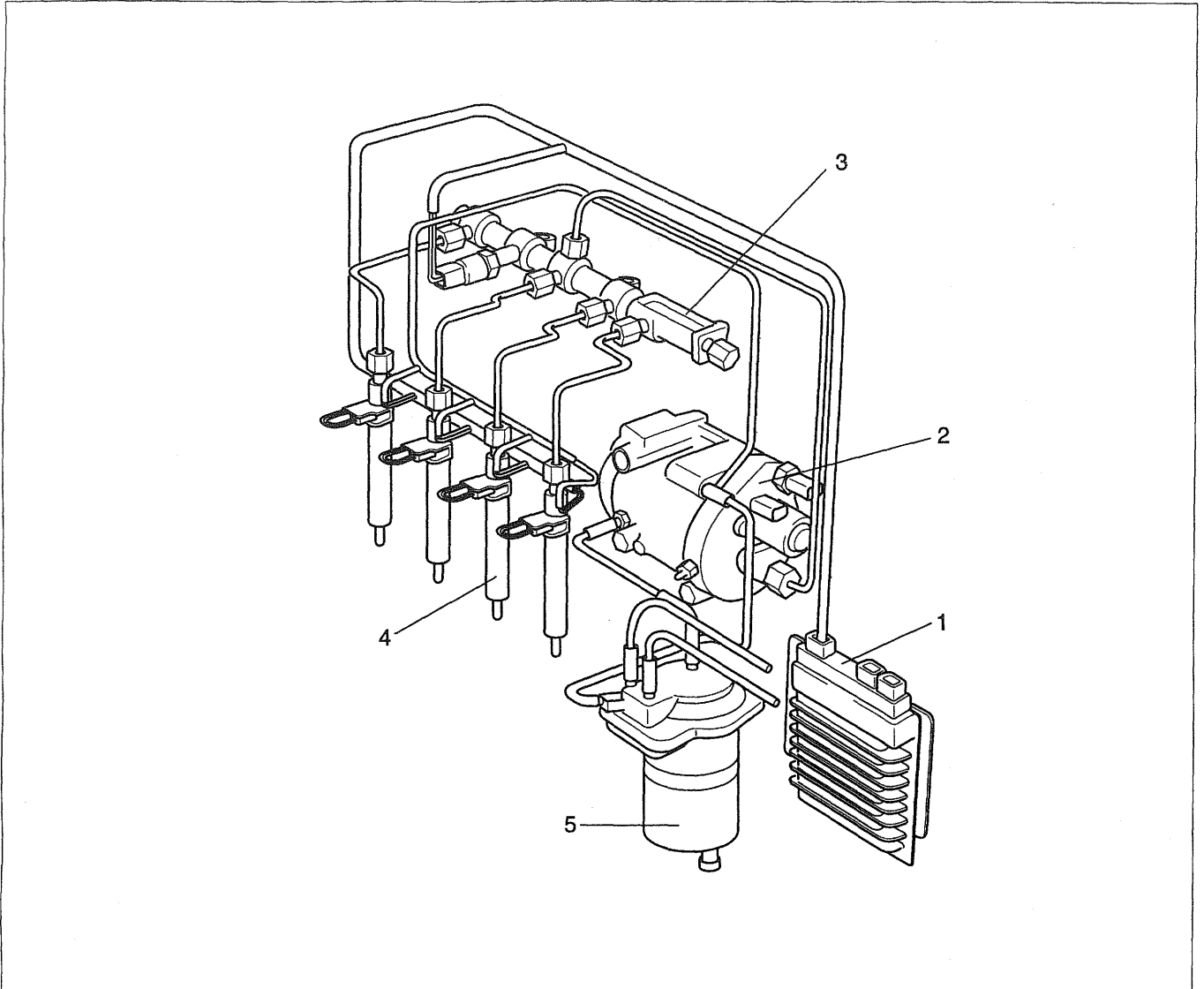

- 1. ECM
- 2. High Pressure Pump (Transfer Pump Integrated)
- 3. Common Rail
- 4. Injector
- 5. Fuel Filter

EWMF125A

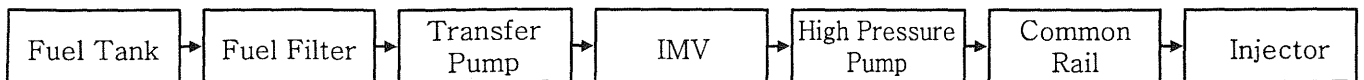

EWMF101H

⊗ WARNING

- Common Rail Fuel Injection System is subject to extremely high pressure (Approximately 1,600 bar)
- Never perform any work on injection system with engine running or within 30 seconds after the engine stops.
- Always pay attention to safety precaution.
- Ensure the absolute cleanliness.
- It is not recommended to remove the injectors without any notice.

LOW PRESSURE LINE**1. FUEL TANK****2. TRANSFER PUMP**

The transfer pump is included in the housing of the HP pump. The transfer pump is of the volumetric blade type pump. The pump draws the fuel from the fuel tank and continually delivers the required quantity of fuel in the direction of the high-pressure pump.

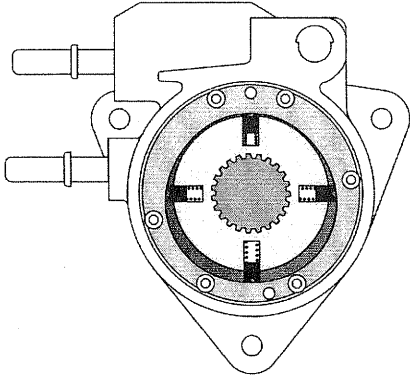

AFBE145A

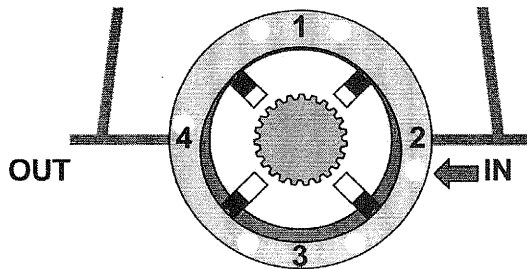

AFBE145B

3. FUEL FILTER

Inadequate filtering can lead to damage at the pump components, delivery valves, and injector nozzles. The fuel filter cleans the fuel before it reaches the lift pump, and thereby prevents premature wear at the pump's sensitive components.

4. HAND PRIME PUMP

HIGH PRESSURE CIRCUIT

1. HIGH PRESSURE PUMP

The high pressure pump pressurises the fuel to a system pressure of up to 1,600bar. This pressurized fuel then passes through a high-pressure line and into the tubular high-pressure common rail.

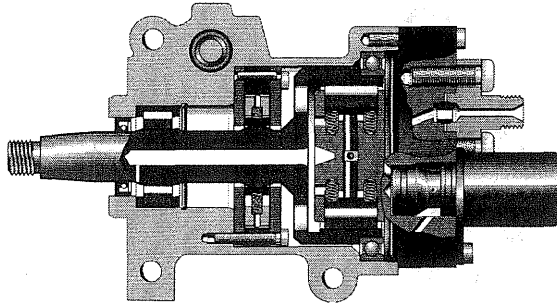

AFBE145F

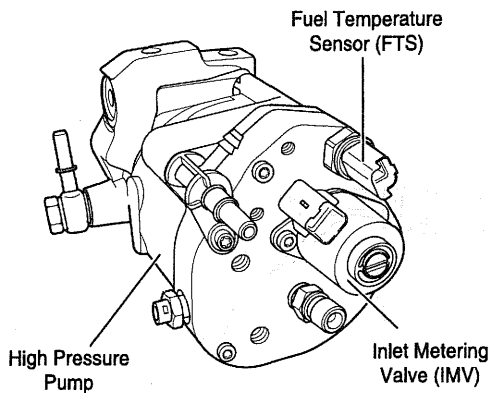

EWMF101K

2. COMMON RAIL

Even after an injector has taken fuel from the rail in order to inject it, the fuel pressure inside the common rail remains practically constant. This is due to the common rail effect arising from the fuel's inherent elasticity. Fuel pressure is measured by the rail pressure sensor and maintained at the desired level by the pressure control valve. It is the job of the inlet metering valve to limit the fuel pressure in the common rail to maximum 160 MPa (23,206 psi) The highly pressurized fuel is directed from the rail to the injectors by a flow limiter, which prevents excess fuel reaching the combustion chamber.

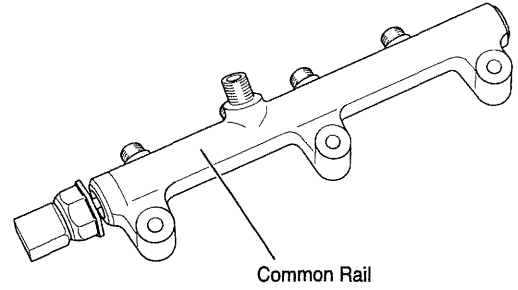

EWMF101L

3. HIGH PRESSURE PIPE

These fuel lines carry the high-pressure fuel. They must therefore be able to permanently withstand the maximum system pressure and, during the pauses in injection, the sometimes high frequency pressure fluctuations which occur. They are therefore manufactured from steel tubing. Normally, they have an outside diameter of 6 mm and an internal diameter of 2.4 mm.

The injection lines between the common rail and the injectors must all be of the same length. The differences in length between the common rail and the individual injectors are compensated for by using slight or pronounced bends in the individual lengths of tubing. Nevertheless, the injection lines should be kept as short as possible.

4. INJECTORS

The nozzles of these injectors open when the solenoid valve is triggered and permit the flow of fuel. They inject the fuel directly into the engine's combustion chamber. The excess fuel which was needed for opening the injector nozzles flowsback to the tank through a collector line. The return fuel from the pressure control valve and from the low-pressure stage is also led into this collector line together with the fuel used to lubricate the high-pressure pump.

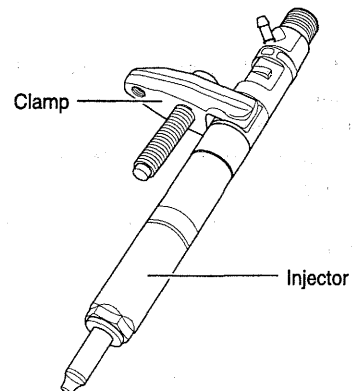

EWMF101M

COMPONENTS ECCC9D93

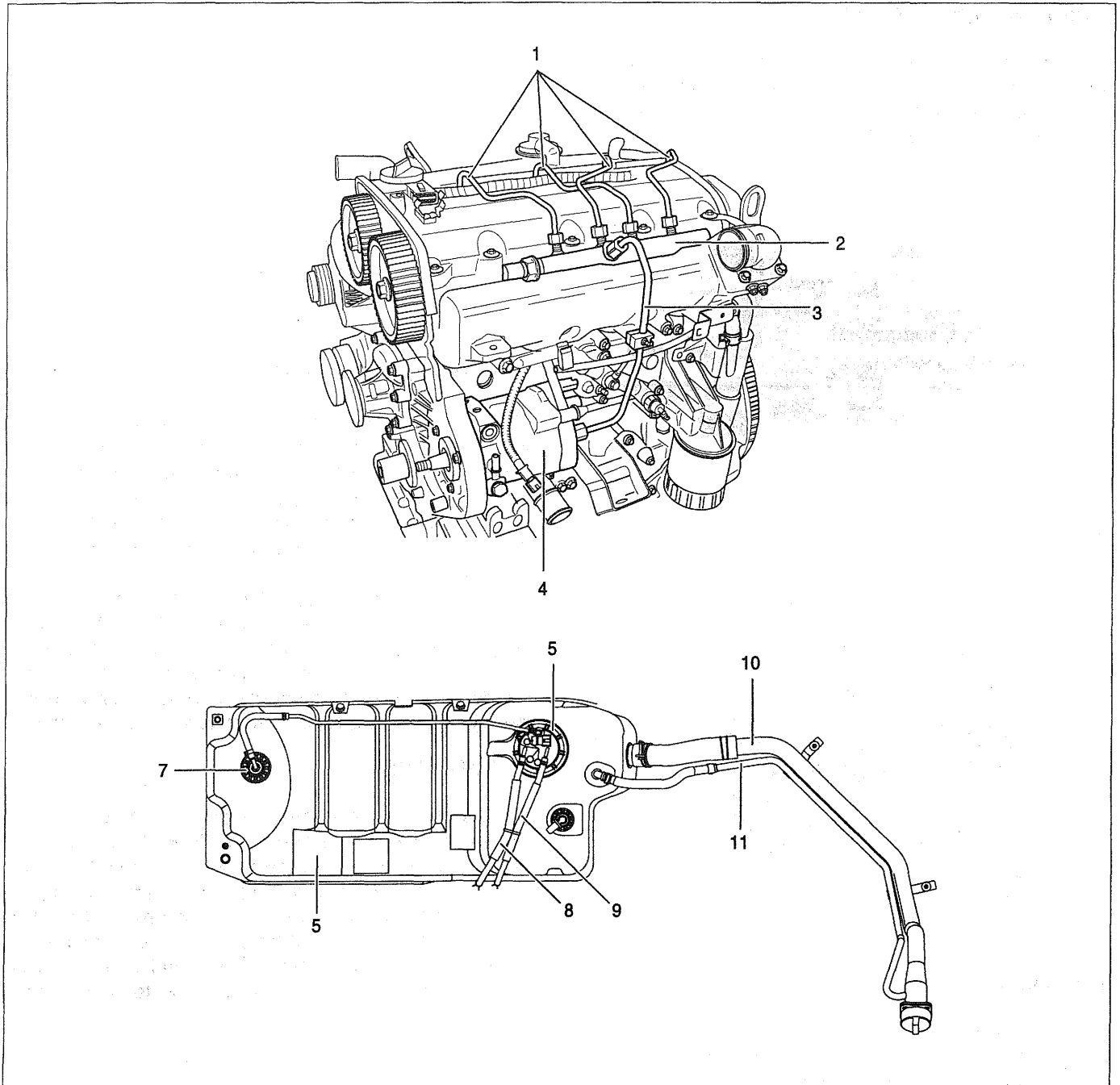

- 1. High Pressure Pipe (Common Rail ↔ Injector)
- 2. Common Rail
- 3. High Pressure Pipe
(High Pressure Pump ↔ Common Rail)
- 4. High Pressure Pump
(FTS, IMV and Transfer Pump integrated)
- 5. Fuel Sender

- 6. Fuel Tank
- 7. Fuel Sender (Sub)
- 8. Return Hose
- 9. Fuel Feed Hose
- 10. Fuel Filler Hose
- 11. Breather Hose

INJECTOR

REMOVAL E0A9B2A1

⊗ WARNING

- Common Rail Fuel Injection System is subject to extremely high pressure (Approximately 1,600 bar)
- Never perform any work on injection system with engine running or within 30 seconds after the engine stops.
- Always pay attention to safety precaution.
- Ensure the absolute cleanliness.
- It is not recommended to remove the injectors without any notice.

1. Disconnect the injector connector (A).

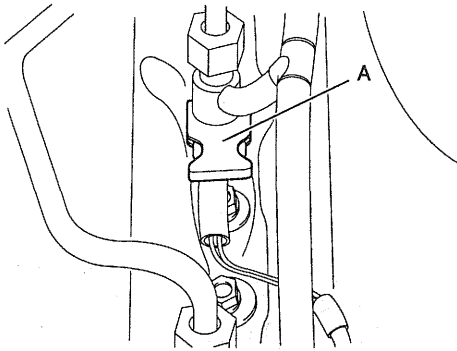

AFBE100T

2. Disconnect the injector return hose (A).

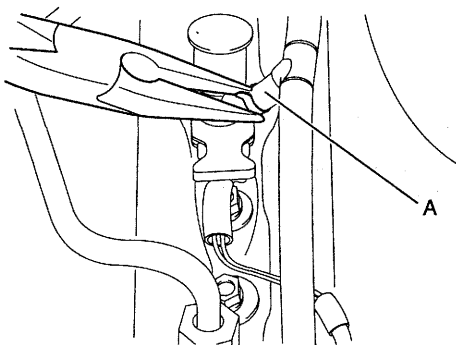

AFBE100U

3. Remove the high pressure pipe mounting nut (A) on the common rail and injector, and then remove the high pressure pipe(B).

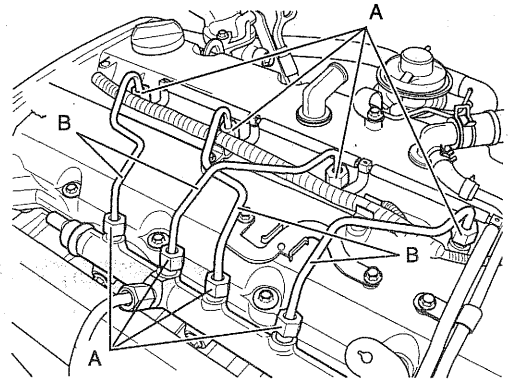

AFBE102L

4. Remove the injector clamp bolt (A) using a hexagonal-wrench and remove the clamp(B) and injector(C).

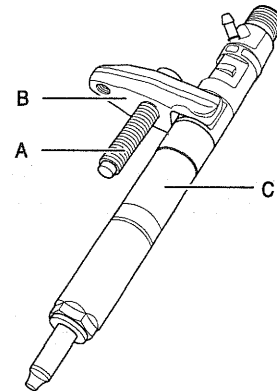

AFBE102M

INSTALLATION E56B54E3

NOTE

The new injector possesses different characteristics from the one which was originally fitted to the engine. These characteristics are summarized in the 16-character code shown on the label stuck to the top of the injector holder. This code must be entered into the ECM memory with the Hi-Scan (Pro).

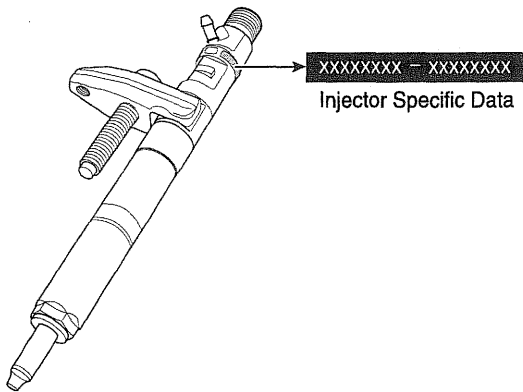

EWMF1020

CAUTION

When installing a new injector, **MUST** replace the injector clamp bolt(A) and gasket(B) with a new one.

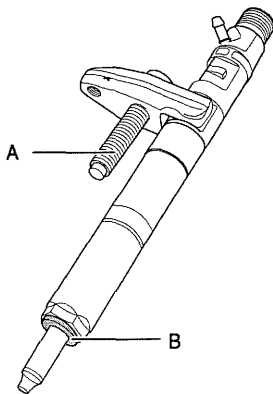

AFBE102N

1. Place the injector(C) and clamp(B) on the engine block and install the injector clamp bolt(A).

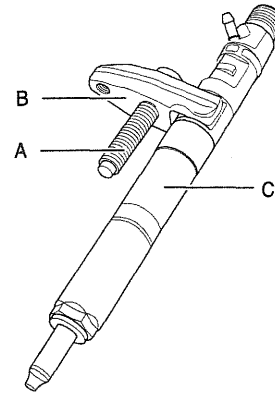

AFBE102M

2. Install the high pressure pipe(B) in between the common rail and injector with installing the nut (A).

Tightening Torques: 3.65 ~ 4.35 Kgf-m (35.79 ~ 42.66 N·m, 26.40 ~ 31.46 lbf-ft)

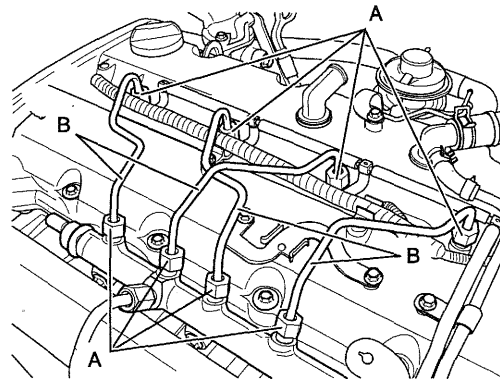

AFBE102L

CAUTION

When installing the high pressure pipe, spread specified lubricating oil on the nut.

3. Connect the injector return hose (A).

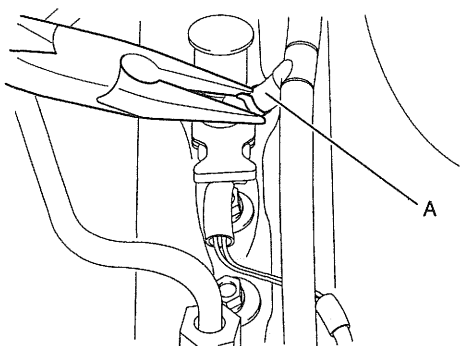

AFBE100U

⚠ CAUTION

When installing a new injector, MUST replace the injector return hose clamp with a new one.

4. Connect the injector connector(A).

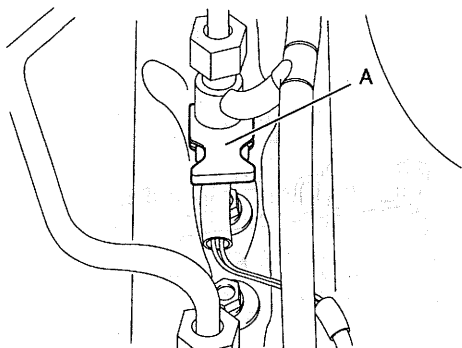

AFBE100T

ACCUMULATOR

REMOVAL ED9CD89F

⊗ WARNING

- Common Rail Fuel Injection System is subject to extremely high pressure (Approximately 1,600 bar)
- Never perform any work on injection system with engine running or within 30 seconds after the engine stops.
- Always pay attention to safety precaution.
- Ensure the absolute cleanliness.
- It is not recommended to remove the injectors without any notice.

1. Disconnect the rail pressure sensor connector (A).

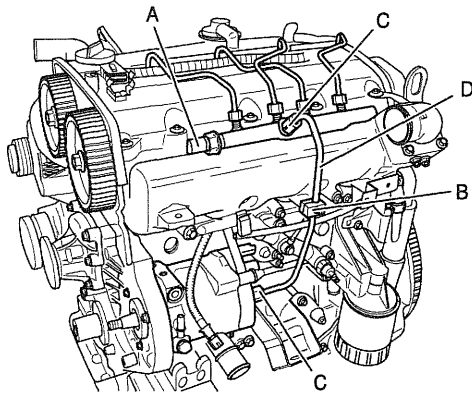

AFBE102Q

2. Remove the high pressure pipe fixing clip(B).
3. Remove the high pressure pipe (D) with unscrewing the mounting nut (C).
4. Remove the intake manifold (Refer to the group "EM" in this Shop Manual).

5. Remove the high pressure pipe mounting nut (A) on the common rail and injector, and then remove the high pressure pipe(B).

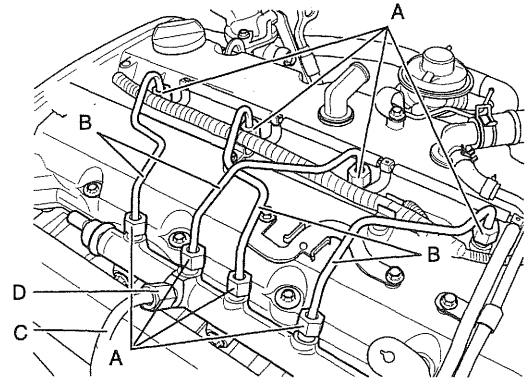

AFBE112L

6. Remove the high pressure pipe mounting nut (D) on the common rail and high pressure pump, and then remove the high pressure pipe(C).
7. Remove the common rail mounting bolts (A).

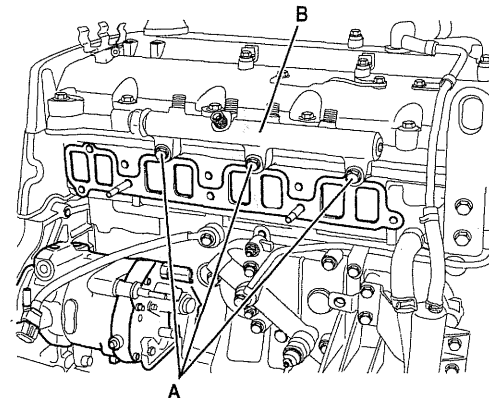

AFBE102P

8. Remove the common rail (B).

INSTALLATION E3C81425

1. Place the common rail (B) on the engine block and screw the mounting bolts (A).

Tightening Torques: 1.90 ~ 2.30 Kgf·m (18.63 ~ 22.56 N·m, 13.74 ~ 16.64 lbf·ft)

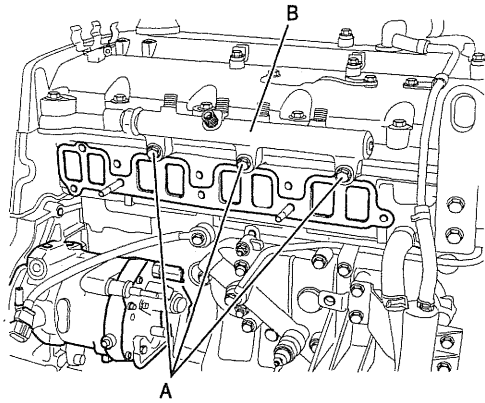

AFBE102P

2. Install the high pressure pipe (B) in between injector and common rail with screwing the mounting nut (A).

Tightening Torques: 3.65 ~ 4.35 Kgf·m (35.79 ~ 42.66 N·m, 26.40 ~ 31.46 lbf·ft)

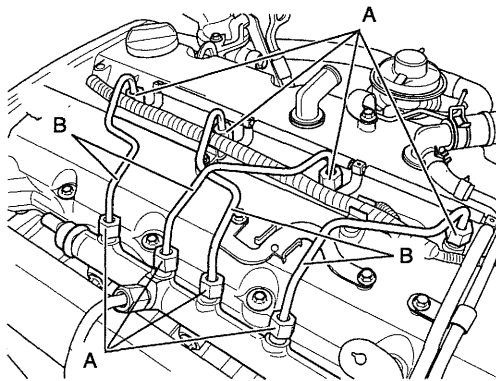

AFBE102L

CAUTION

When installing the high pressure pipe, spread specified lubricating oil on the nut.

3. Install the intake manifold (Refer to the group "EM" in this Shop Manual).

4. Install the high pressure pipe (D) in between high pressure pump and the common rail with screwing the mounting nut (C).

Tightening Torques: 3.65 ~ 4.35 Kgf·m (35.79 ~ 42.66 N·m, 26.40 ~ 31.46 lbf·ft)

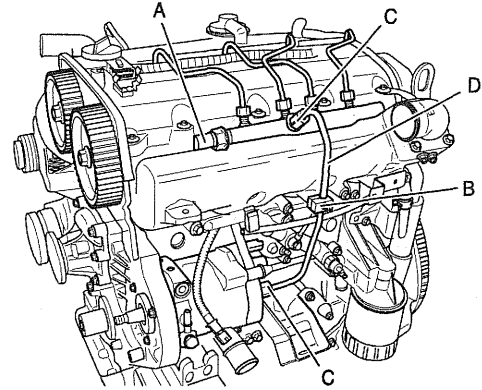

AFBE102Q

CAUTION

When installing the high pressure pipe, spread specified lubricating oil on the nut.

5. Install the fixing clip (B) on the intake manifold.
6. Connect the rail pressure sensor connector (A).

FUEL LINE

REMOVAL E2DB4DCB

⊗ WARNING

- Common Rail Fuel Injection System is subject to extremely high pressure (Approximately 1,600 bar)
- Never perform any work on injection system with engine running or within 30 seconds after the engine stops.
- Always pay attention to safety precaution.
- Ensure the absolute cleanliness.
- It is not recommended to remove the injectors without any notice.

HIGH PRESSURE PIPE (INJECTOR ↔ COMMON RAIL)

1. Remove the high pressure pipe mounting nut (A) on the common rail and injector, and then remove the high pressure pipe(B).

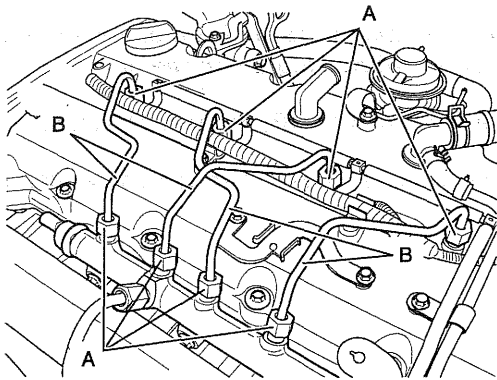

AFBE102L

HIGH PRESSURE PIPE (COMMON RAIL ↔ HIGH PRESSURE PIPE)

1. Remove the high pressure pipe fixing clip(A).
2. Remove the high pressure pipe mounting nut (B) on the common rail and high pressure pump, and then remove the high pressure pipe(C).

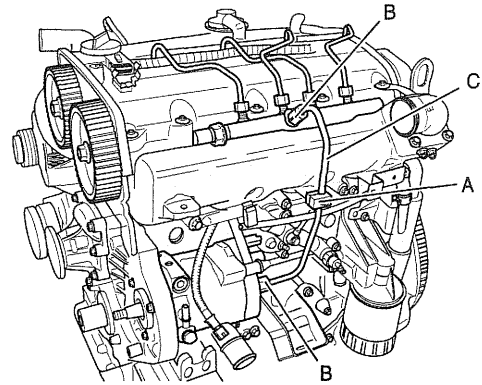

AFBE101O

INSTALLATION E1E0265D

HIGH PRESSURE PIPE (INJECTOR ↔ COMMON RAIL)

1. Install the high pressure pipe (B) in between injector and common rail with screwing the mounting nut (A).

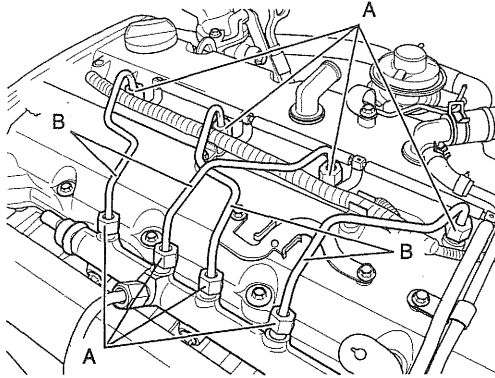

AFBE102L

Tightening Torques: 3.65 ~ 4.35 Kgf·m (35.79 ~ 42.66 N·m, 26.40 ~ 31.46 lbf·ft)

⚠ CAUTION

When installing the high pressure pipe, spread specified lubricating oil on the nut.

HIGH PRESSURE PIPE (COMMON RAIL ↔ HIGH PRESSURE PIPE)

1. Install the high pressure pipe (C) in between injector and common rail with screwing the mounting nut (B).

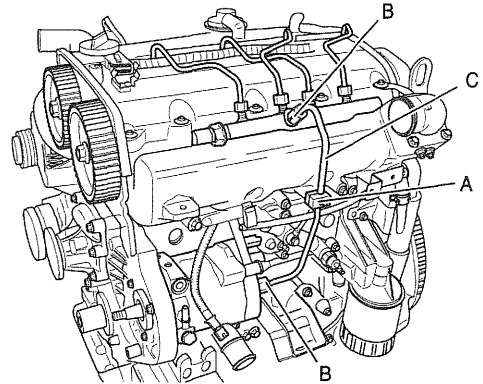

AFBE101O

Tightening Torques: 3.65 ~ 4.35 Kgf·m (35.79 ~ 42.66 N·m, 26.40 ~ 31.46 lbf·ft)

⚠ CAUTION

When installing the high pressure pipe, spread specified lubricating oil on the nut.

2. Install the fixing clip (A) on the intake manifold.