



CONTENTS

Terracan

Electrical Troubleshooting Manual

FOREWORD

This manual is intended for use by service technicians of authorized Hyundai dealers to help them provide efficient and correct service and maintenance on Hyundai vehicle.

To ensure customer satisfaction with Hyundai products, proper service and maintenance by Hyundai technicians is essential. Consequently, it is important that service personnel fully understand the contents of this manual, which should be kept in a handy place for quick and easy reference.

All the contents of this manual, including photographs, drawings, and specifications, are the latest available at the time of printing. As modifications affecting service occur, dealers will be provided technical service bulletins or supplementary volumes. This manual should be kept carefully up-to-date upon receipt of the new information.

Hyundai Motor Company reserves the right to make changes in design or to make additions to or improvements in its products without imposing any obligations upon itself to install them on its products previously manufactured.

AUG. 2003, Printed in Korea

TITLE	ID
-------	----

HOW TO USE THIS MANUAL	GI	
------------------------	----	---

SCHEMATIC DIAGRAMS	SD	
--------------------	----	---

COMPONENT LOCATIONS	CL	
---------------------	----	---

CONNECTOR CONFIGURATIONS	CC	
--------------------------	----	---

HARNESS LAYOUTS	HL	
-----------------	----	---

All rights reserved. No part of this publication may be reproduced, stored in any retrieval system or transmitted in any form or by any means without the prior written permission of Hyundai Motor Company.

HARNESSES LAYOUTS

A/C & A/BAG HARNESS	HL-17
DOOR HARNESS	HL-12
FRONT HARNESS	HL-4
INSTRUMENT HARNESS.....	HL-10
MAIN HARNESS	HL-2
REAR HARNESS	HL-14
T/M HARNESS	HL-11

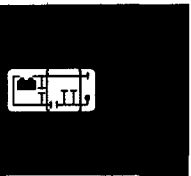

MAIN HARNESS E4B4D0FD

MAIN HARNESS (1)

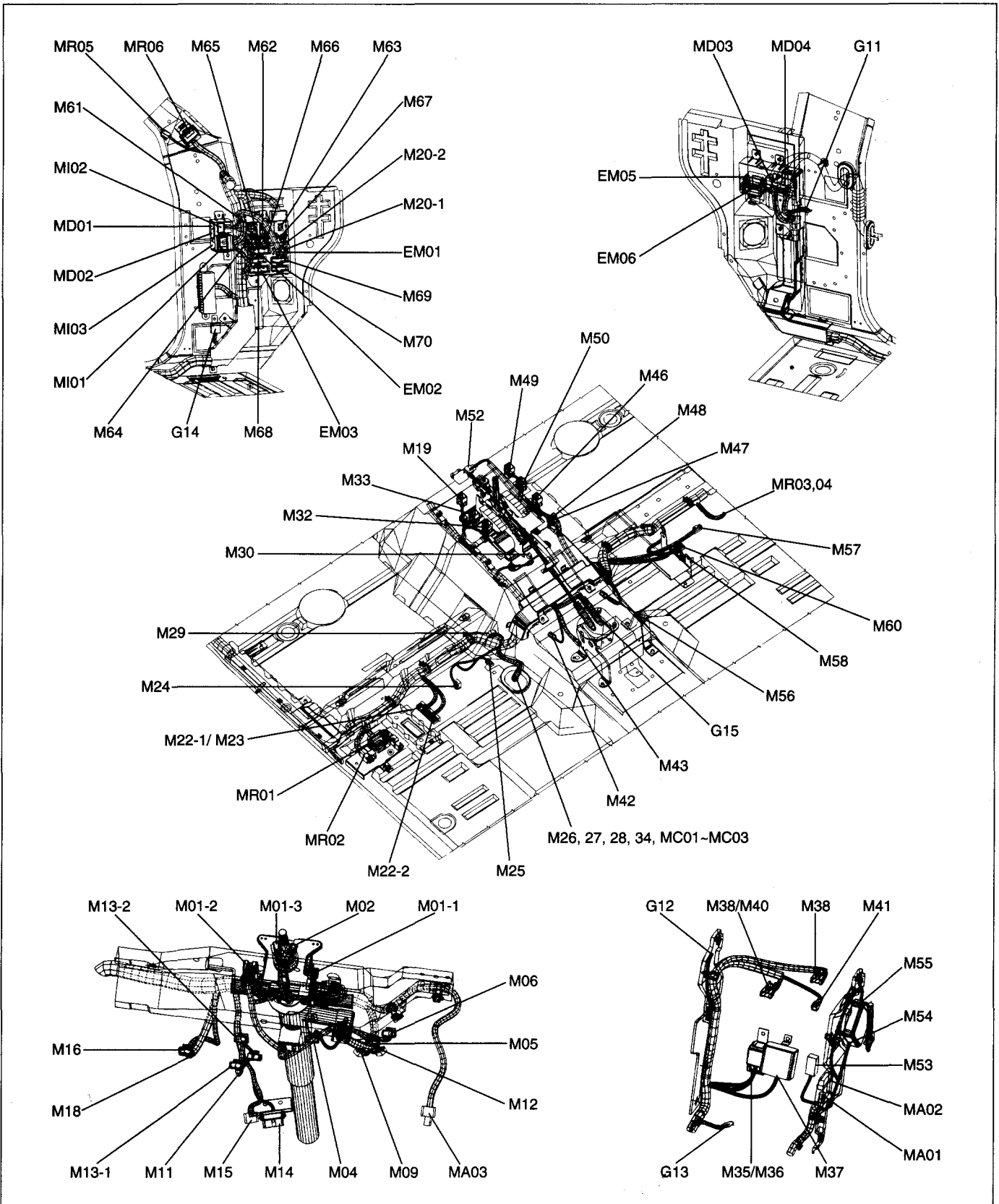

MAIN HARNESS (2)

M01-1	Multifunction switch	M61	Defogger relay
M01-2	Multifunction switch	M62	Flasher unit
M01-3	Multifunction switch	M63	Power window relay
M02	Driver air bag	M64	Power door lock relay
M04	Humidity sensor	M65	Power door unlock relay
M05	Ignition switch	M66	Rear fog lamp relay
M06	Ignition key ill & Door warning switch	M68	Joint connector
M07	Accelerator position sensor (2.9TCI)	M69	Joint connector
M08	Immobilizer control module (2.9TCI)	M70	Joint connector
M09	Joint connector	M76	Cruise clutch pedal position switch (Gasoline)
M10	Condenser	MA01	Connection with A/C harness
M11	Stop lamp switch	MA02	Connection with A/C harness
M12	Joint connector	MA03	Connection with AIR BAG harness
M13-1	ETACM	MC01	Connection with T/M harness (M/T)
M13-2	ETACM	MC02	Connection with T/M harness (A/T)
M14	Data link connector	MC03	Connection with T/M harness (A/T)
M15	Multipurpose check connector	MD01	Connection with LEFT FRONT DOOR harness
M16	Clutch pedal position switch	MD02	Connection with LEFT FRONT DOOR harness
M18	DRL control module	MD03	Connection with RIGHT FRONT harness
M20-1	TCM	MD04	Connection with RIGHT FRONT harness
M20-2	TCM	EM01	Connection with FRONT harness
M22-1	TOD control module	EM02	Connection with FRONT harness
M22-2	TOD control module	EM03	Connection with FRONT harness
M23	EST control module	EM05	Connection with FRONT harness
M24	Left seat warmer	EM06	Connection with FRONT harness
M25	Seat belt switch	MI01	Connection with INSTRUMENT harness
M26	T/F shift motor (TOD)	MI02	Connection with INSTRUMENT harness
M27	T/F speed sensor (TOD)	MI03	Connection with INSTRUMENT harness
M28	7 way shift motor (EST)	MM01	Connection with POWER SEAT harness
M29	Joint connector	MR01	Connection with LEFT REAR harness
M30	O/D switch	MR02	Connection with LEFT REAR harness
M31	Joint connector	MR03	Connection with RIGHT REAR harness
M33	Rear wiper & washer switch	MR05	Connection with ROOF harness
M34	3 way speed sensor (EST)	MR06	Connection with ROOF harness
M35	Chime bell	G11	Ground
M40	Audio	G12	Ground
M42	Neutral relay	G13	Ground
M43	Parking brake switch	G14	Ground
M46	Front power outlet	G15	Ground
M47	TOD switch	Z03	Diode (Diesel)
M48	EST switch		
M49	Left seat warmer switch		
M50	Right seat warmer switch		
M52	G-sensor (ABS)		
M53	Cigarette lighter		
M54	Keyless receiver	M71	Power seat switch
M55	Immobilizer control module (Except 2.9TCI)	M72	Slide adjust motor
M56	Hazard relay	M73	Reclining adjust motor
M57	Right seat warmer	M74	Front height adjust motor
		M75	Rear height adjust motor
		MM01	Connection with MAIN harness

POWER SEAT HARNESS

FRONT HARNESS EB3E1EC9

FRONT HARNESS (1)

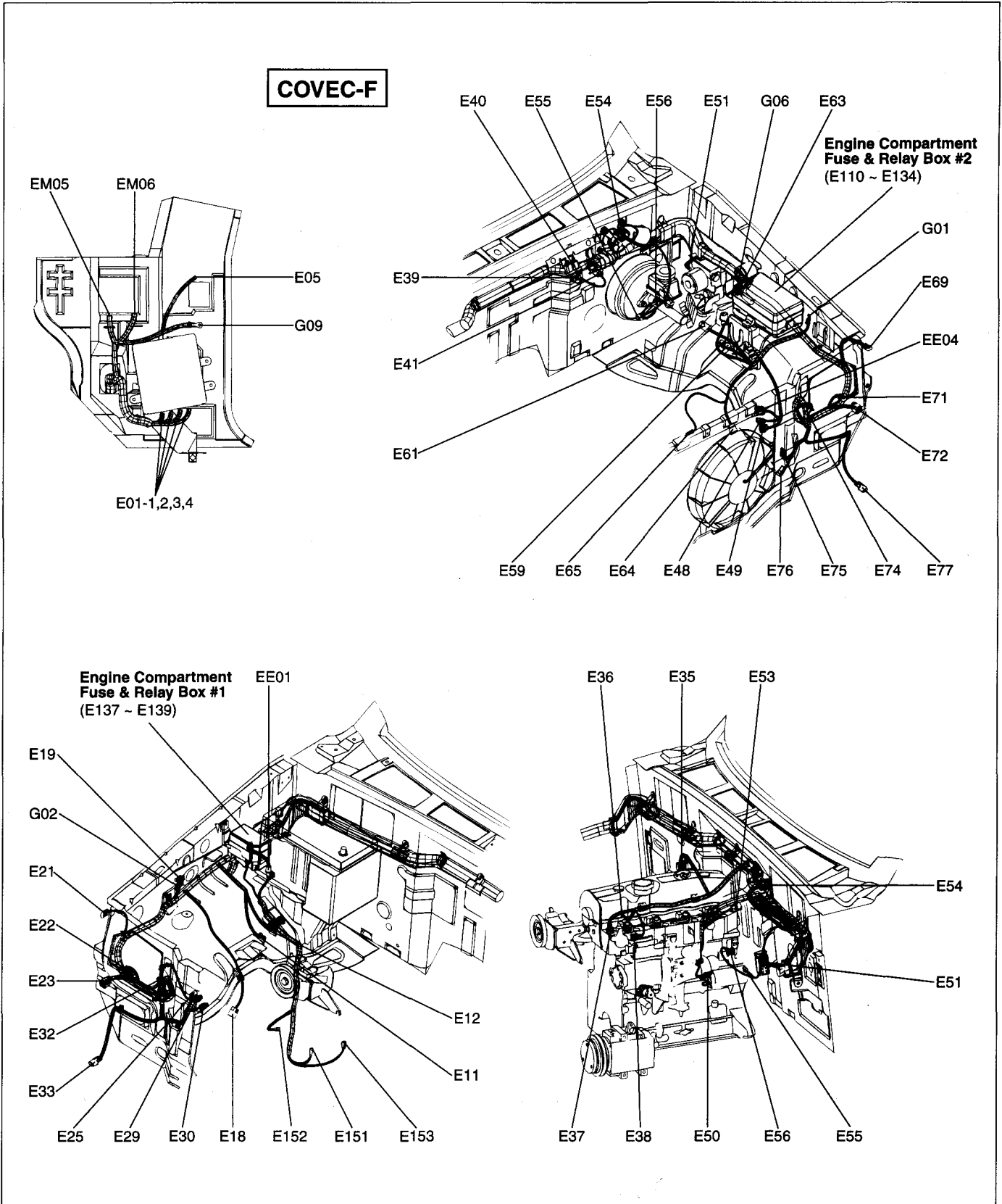

FRONT HARNESS (COVEC-F) (2)

E01-1	ECM	E76	Ambient sensor (Auto A/C)
E01-2	ECM	E77	Left front fog lamp
E01-3	ECM	E110	Condenser fan relay #1
E01-4	ECM	E111	Condenser fan relay #2
E05	Fuel heater control module	E113	Engine control relay
E06	DTC	E115	Burglar alarm relay
E07	Front washer motor	E116	TCI fan relay
E08	Rear washer motor	E117	Tail lamp relay
E10	Right side repeater lamp	E118	Head lamp relay (LOW)
E11	CADS solenoid #1 (EST)	E119	Head lamp relay (HIGH)
E12	CADS solenoid #2 (EST)	E120	Pre-excitation resistor
E18	Right front wheel sensor (ABS)	E121	A/C compressor relay
E19	Hood switch	E123	Power outlet relay
E21	Right front turn signal lamp	E124	Start relay
E22	Right head lamp leveling actuator	E125	EBD relay
E23	Right head lamp	E126	ABS relay
E25	Receiver drier	E127	Front wiper relay
E29	Condenser fan motor	E130	Joint connector
E30	Radiator fan motor	E131	Joint connector
E32	Right horn (LOW)	E132	Joint connector
E33	Right front fog lamp	E133	Joint connector
E35	BPS & ATS	E134	Joint connector
E36	Glow plug	E135	Joint connector
E37	Engine coolant temperature sensor	E137	Horn relay
E38	Engine coolant temperature switch	E138	Front fog lamp relay
E39	EGR solenoid #1	E139	Glow relay
E40	EGR solenoid #2	EE01	Connection with GENERATOR harness
E48	Timing position sensor	EE04	Connection with INJECTION PUMP harness
E49	NPS & FCV	EM01	Connection with MAIN harness
E50	Start motor solenoid	EM02	Connection with MAIN harness
E51	ABS control module	EM03	Connection with MAIN harness
E53	TCI fan motor	EM05	Connection with MAIN harness
E54	Front wiper motor	EM06	Connection with MAIN harness
E55	Vacuum switch	G01	Ground
E56	Brake fluid level switch	G02	Ground
E57	Left side repeater lamp	G04	Ground
E59	Water level switch	G06	Ground
E60	Heater & sensor		
E61	Accelerator position sensor		
E63	Siren		
E64	Left front wheel sensor (ABS)	E150	Main fuse & relay box
E65	A/C compressor	E151	Generator (B+)
E69	Left front turn signal lamp	E152	Generator (L,S)
E71	Left head lamp leveling actuator	E153	Oil pressure switch
E72	Left head lamp	EE01	Connection with FRONT harness
E74	Left horn (Hi)		

GENERATOR HARNESS

FRONT HARNESS (3)

2.9 TCI

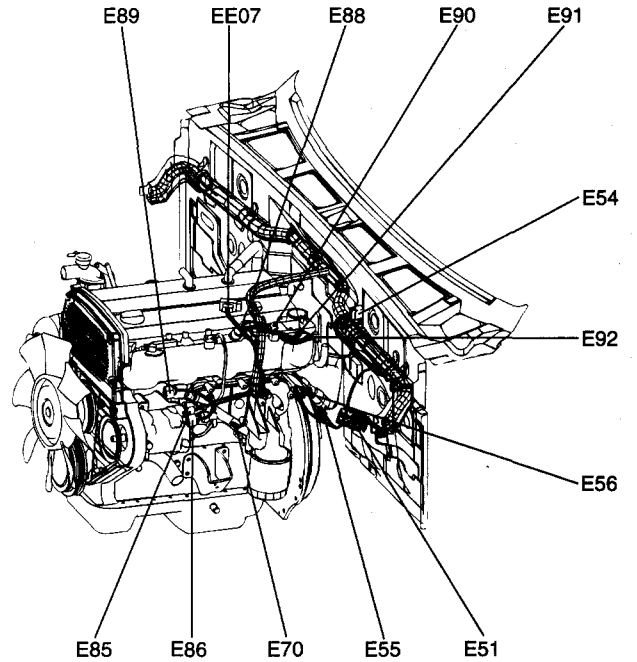
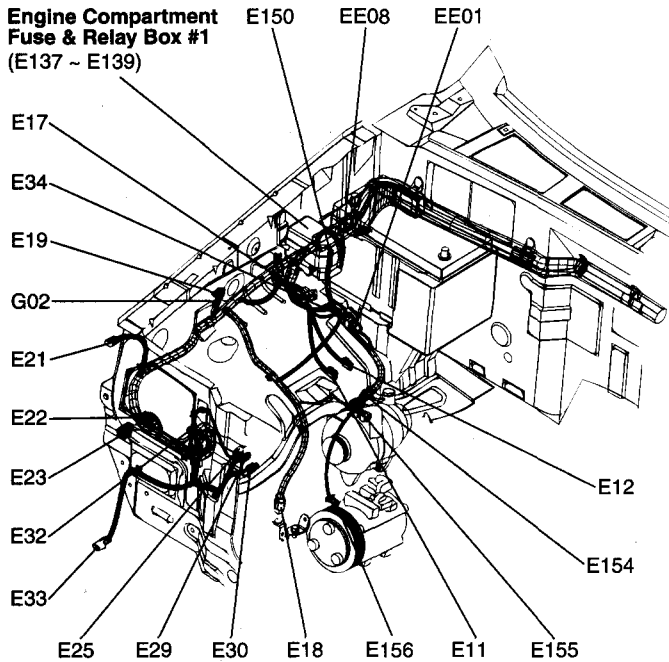
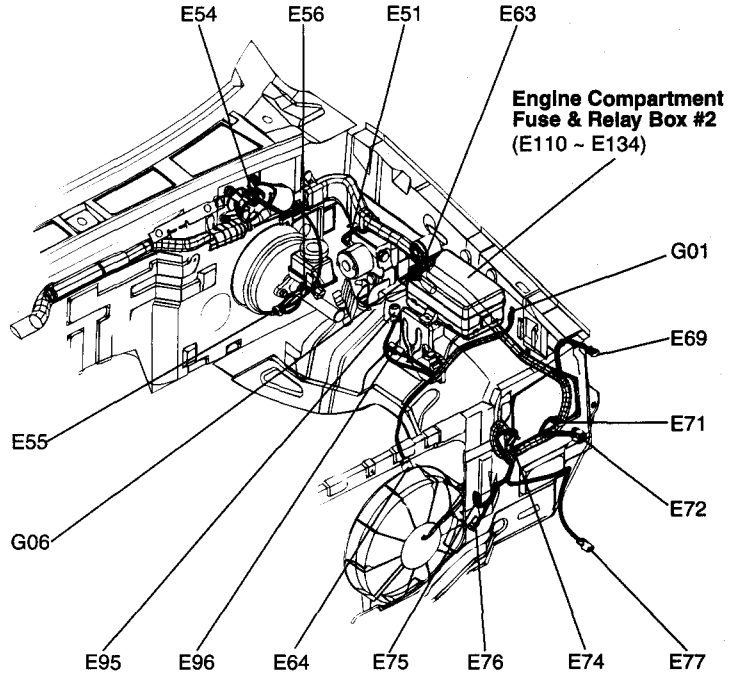
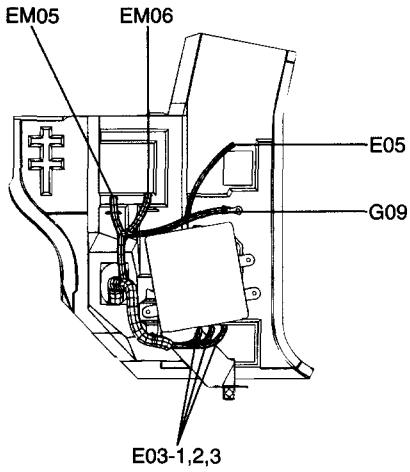

FRONT HARNESS (2.9TCI) (4)

E03-1	ECM	E117	Tail lamp relay
E03-2	ECM	E118	Head lamp relay (LOW)
E03-3	ECM	E119	Head lamp relay (Hi)
E07	Front washer motor	E120	Pre-excitation resistor
E08	Rear washer motor	E121	A/C compressor relay
E10	Right side repeater lamp	E123	Power outlet relay
E11	CADS solenoid #1 (EST)	E124	Start relay
E12	CADS solenoid #2 (EST)	E125	EBD relay
E17	Mass air flow sensor	E126	ABS relay
E18	Right front wheel sensor (ABS)	E127	Front wiper relay
E19	Hood switch	E130	Joint connector
E21	Right front turn signal lamp	E131	Joint connector
E22	Right head lamp leveling actuator	E132	Joint connector
E23	Right head lamp	E133	Joint connector
E25	Reciver dryer	E134	Joint connector
E29	Condenser fan motor	E137	Horn relay
E30	Radiator fan motor	E138	Front fog lamp relay
E32	Righr horn (LOW)	E140	Air heater relay #1
E33	Right front fog lamp	EE02	Connection with GENERATOR harness
E34	EGR solenoid	EE07	Connection with INJECTOR harness
E43	Engine coolant temperature sensor & sender	EE08	Connection with BATTERY CABLE harness
E51	ABS control module	EM01	Connection with MAIN harness
E52	Air heater relay #2	EM02	Connection with MAIN harness
E54	Front wiper motor	EM03	Connection with MAIN harness
E55	Vacuum switch	EM05	Connection with MAIN harness
E56	Brake fluid level switch	EM06	Connection with MAIN harness
E57	Left side repeater lamp	G01	Ground
E63	Siren	G02	Ground
E64	Left front wheel sensor (ABS)	G06	Ground
E69	Left front turn signal lamp	G09	Ground
E70	Oil pressure switch		
E71	Left head lamp leveling actuator		
E72	Left head lamp		
E74	Left horn (High)	E50	Start motor solenoid
E76	Ambient sensor (Auto A/C)	EE08	Connection with FRONT harness
E77	Left front fog lamp		
E85	Fuel temperature sensor		
E86	Inlet metering valve		
E88	Rail pressure sensor	E150	Main fuse & relay box
E89	Knock sensor	E154	Generator (B+)
E90	Camshaft position sensor	E155	Generator (L,S)
E91	Air heater #1	E156	A/C compressor
E92	Air heater #2	EE02	Connection with FRONT harness
E95	Fuel heater & sensor		
E96	Water level switch		
E110	Condenser fan relay #1		
E111	Condenser fan relay #2		
E113	Engine control relay		
E114	CRI relay		
E115	Burglar alarm relay	E157-1	Injector #1
		E157-2	Injector #2
		E157-3	Injector #3
		E157-4	Injector #4
		EE07	Coninection with FRONT harness

BATTERY CABLE HARNESS**GENERATOR HARNESS****INJECTOR HARNESS**

FRONT HARNESS (5)

GASOLINE

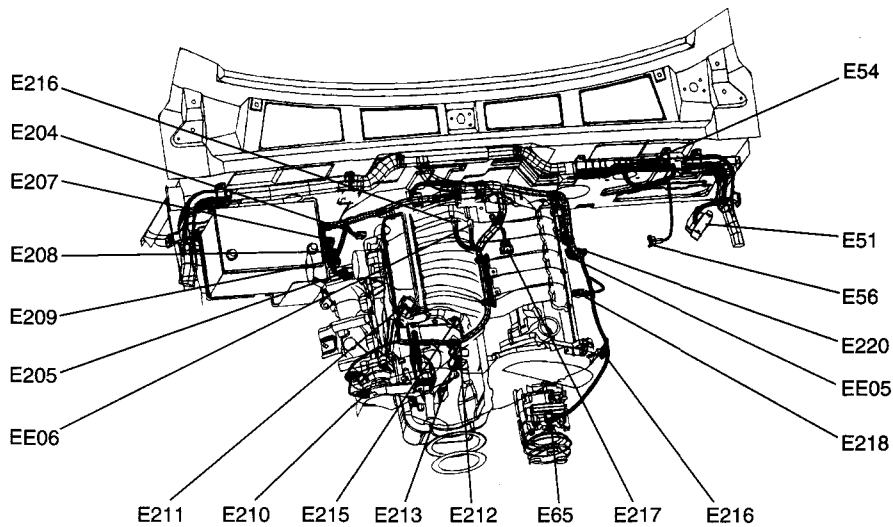
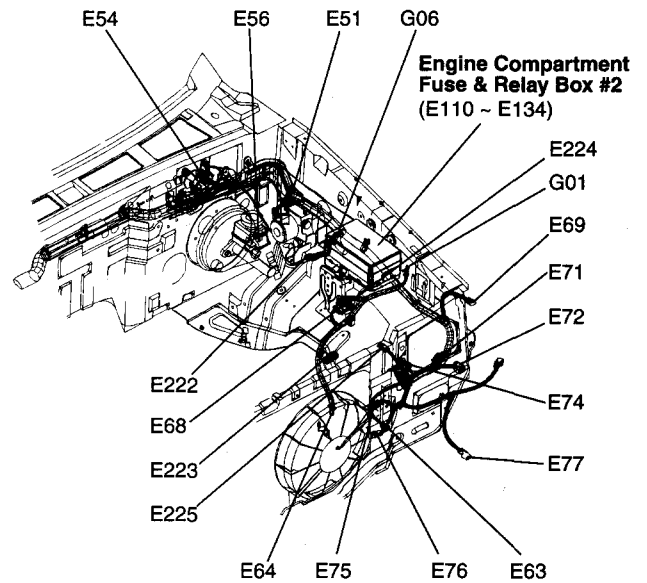
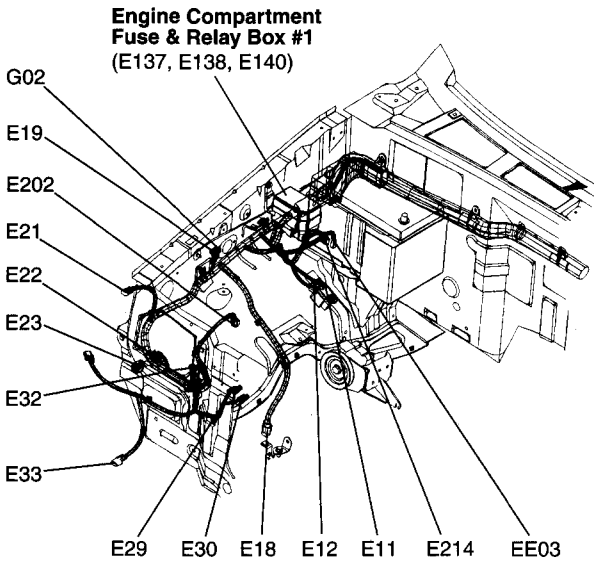
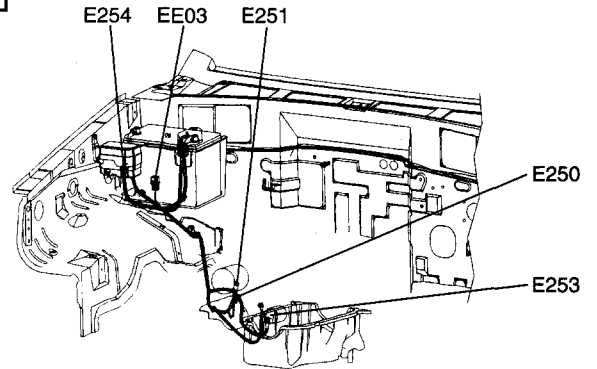
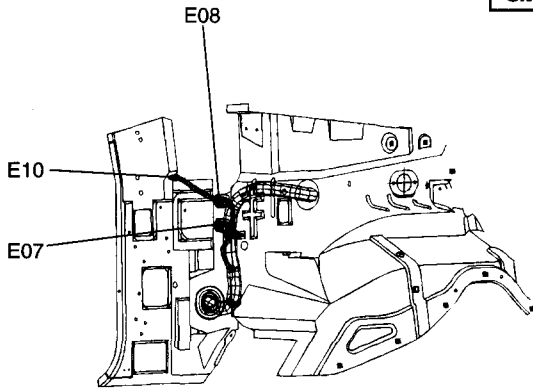

INSTRUMENT HARNESS

E274D45C

INSTRUMENT HARNESS (1)

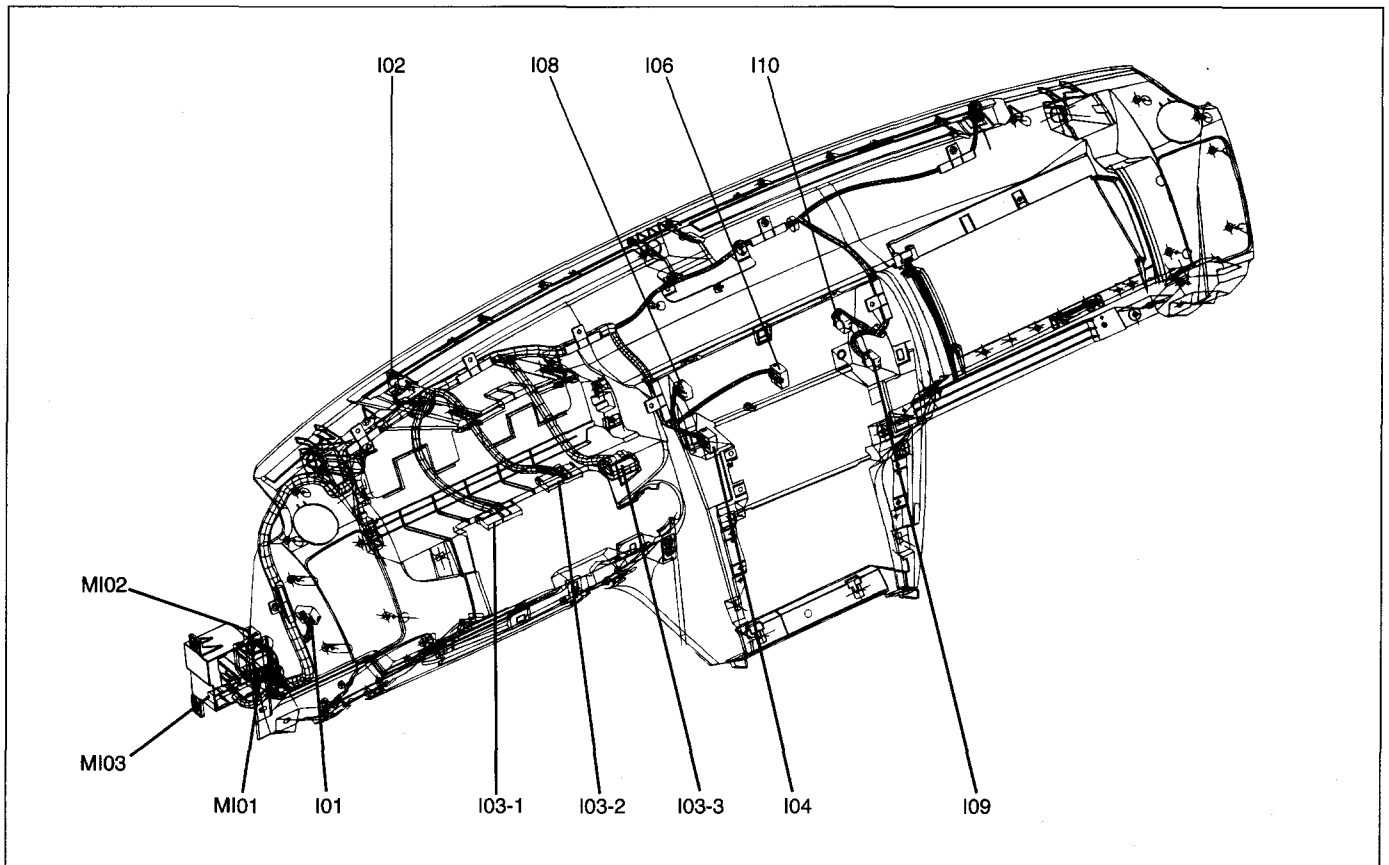

E5ME003A

I01	Joint connector	I08	Rear fog lamp switch
I02	Photo sensor	I09	Head lamp leveling switch
I03-1	Instrument cluster	I10	Cruise switch
I03-2	Instrument cluster	MI01	Connection with MAIN harness
I03-3	Instrument cluster	MI02	Connection with MAIN harness
I04	Rheostat	MI03	Connection with MAIN harness
I06	Hazard switch		

T/M HARNESS EBDAC72

T/M HARNESS (1)

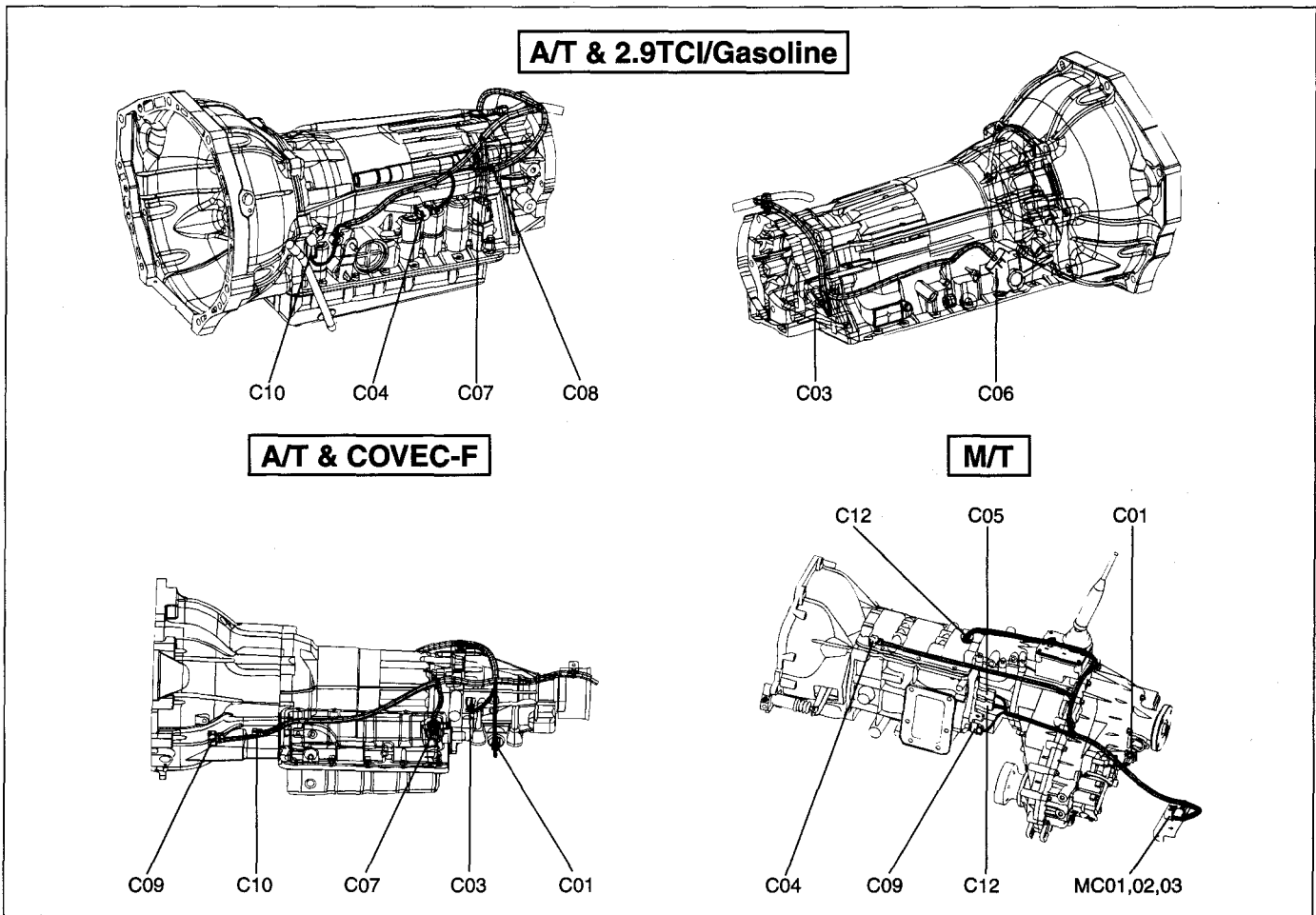

E5ME004A

- | | | | |
|-----|--|------|--|
| C01 | Vehicle speed sensor | C08 | A/T Oil temperature sensor (A/T) |
| C02 | Transaxle range switch (A/T & COVEC-F) | C09 | TDC sensor (COVEC-F) |
| C03 | Output speed sensor (PG-B & A/T) | C10 | Input speed sensor (PG-A & A/T) |
| C04 | Crankshaft position sensor (2.9TCI) | C11 | Back-up lamp switch (Gasoline & M/T) |
| C05 | Neutral switch (COVEC-F & M/T) | C12 | Back-up lamp switch (COVEC-F/2.9TCI & M/T) |
| C06 | Transaxle range switch (A/T & 2.9TCI/Gasoline) | MC01 | Connection with MAIN harness (M/T) |
| C07 | A/T solenoid valve (A/T) | MC02 | Connection with MAIN harness (A/T) |
| | | MC03 | Connection with MAIN harness (A/T) |

DOOR HARNESS

ECE75850

FRONT DOOR HARNESS (1)

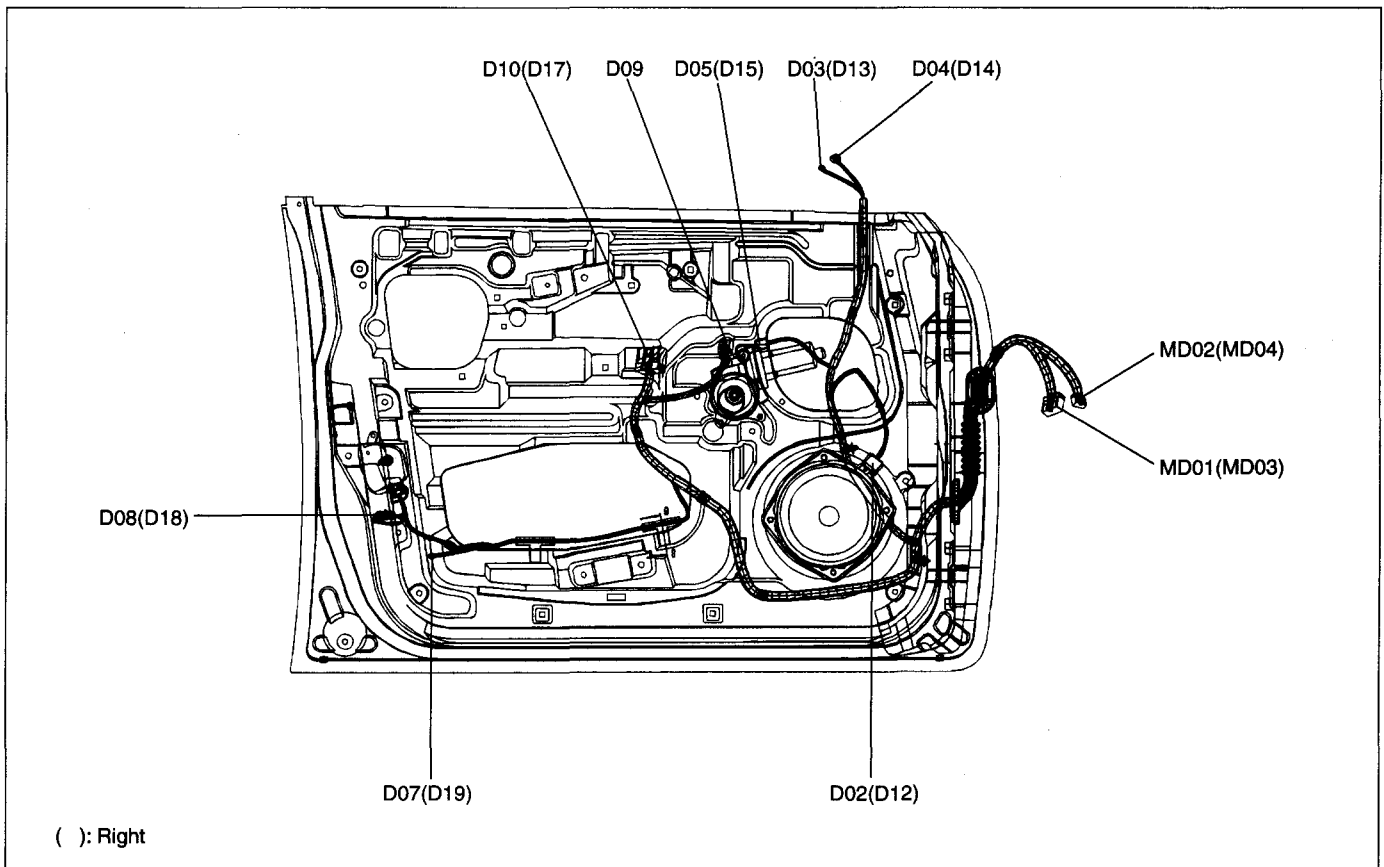

E5ME005A

LEFT FRONT DOOR HARNESS

RIGHT FRONT DOOR HARNESS

D02	Left front door speaker
D03	Left front tweeter speaker
D04	Left outside mirror motor
D05	Left front power window motor
D07	Left front door lamp
D08	Left front door lock actuator
D09	Power outside mirror switch
D10	Power window main switch
MD01	Connection with MAIN harness
MD02	Connection with MAIN harness

D12	Right front door speaker
D13	Right front tweeter speaker
D14	Right outside mirror motor
D15	Right front power window motor
D17	Right front power window switch
D18	Right front door lock actuator
D19	Right front door lamp
MD03	Connection with MAIN harness
MD04	Connection with MAIN harness

REAR DOOR HARNESS (2)

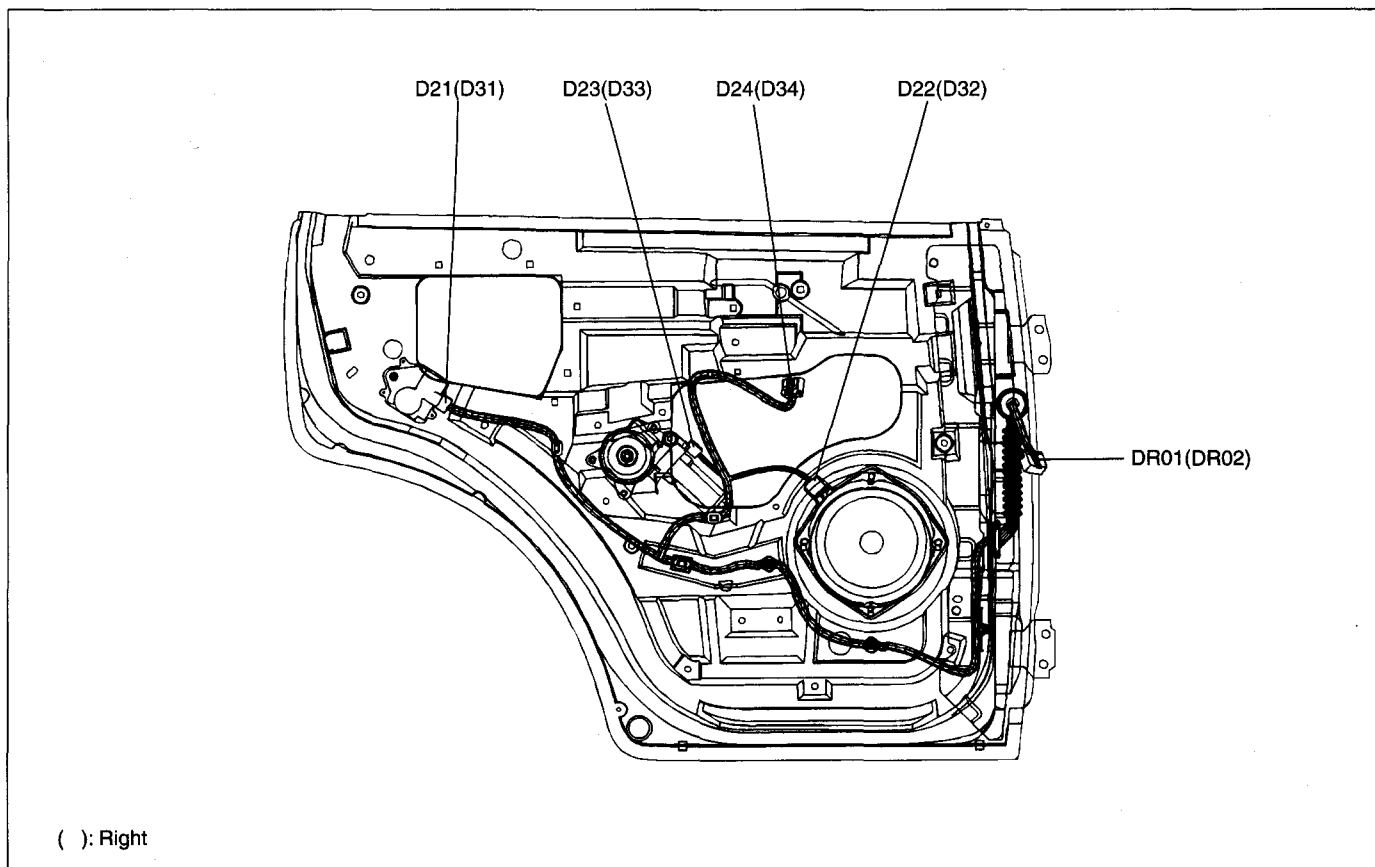

E5ME005B

LEFT REAR DOOR HARNESS

D21	Left rear door lock actuator
D22	Left rear door speaker
D23	Left rear power window motor
D24	Left rear power window switch
DR01	Connection with LEFT REAR harness

RIGHT REAR DOOR HARNESS

D31	Right rear door lock actuator
D32	Right rear door speaker
D33	Right rear power window motor
D34	Right rear power window switch
DR02	Connection with LEFT REAR harness

REAR HARNESS

ED041D9A

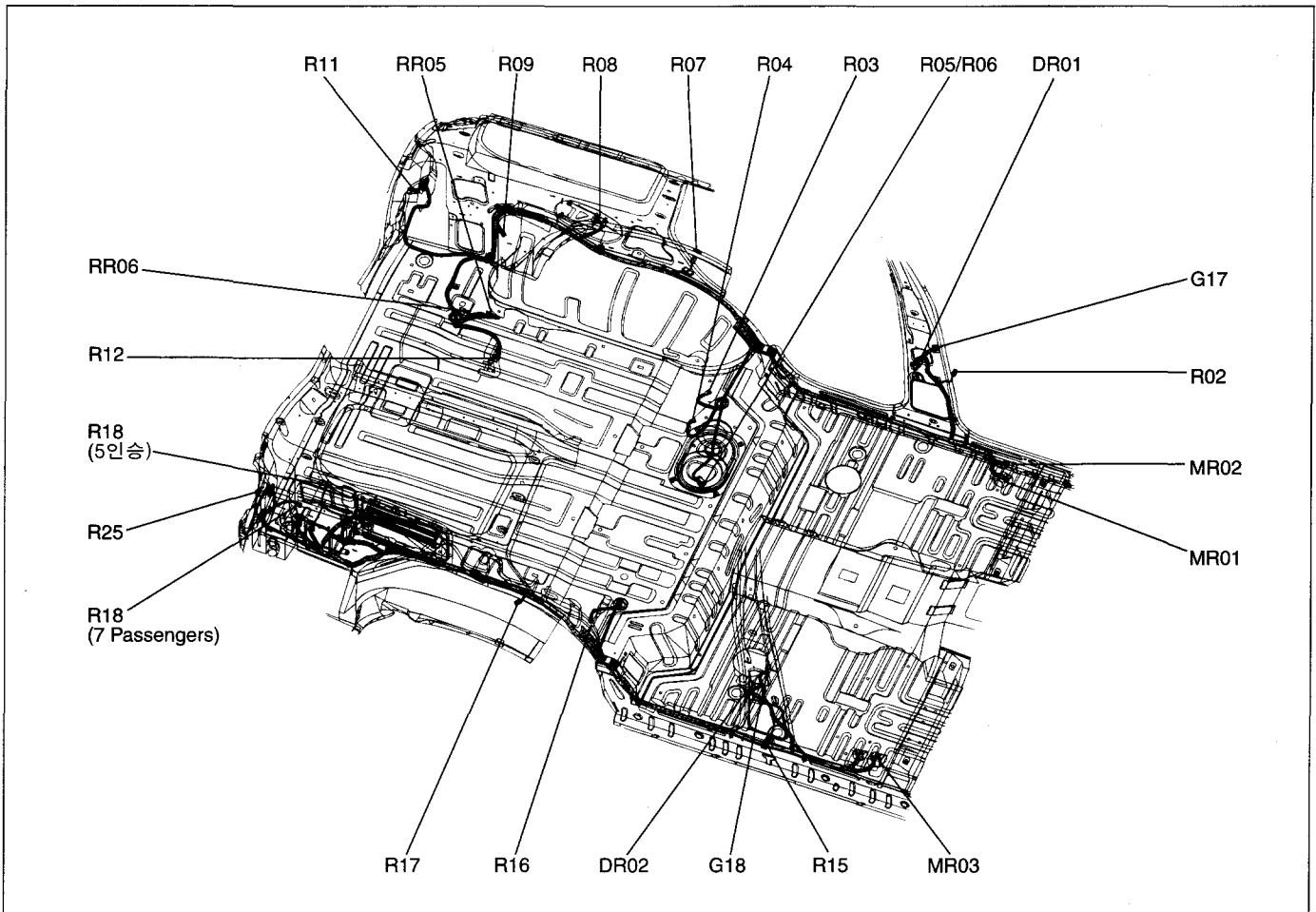
REAR HARNESS (1)

E5ME006A

REAR HARNESS (LEFT)

R02	Left front door switch
R03	Left rear wheel sensor
R05	Fuel tank (Gasoline)
R06	Fuel tank (Diesel)
R07	Left rear door switch
R09	Glass antenna module
R11	Left rear combination lamp
DR01	Connection with REAR DOOR harness
MR01	Connection with MAIN harness
MR02	Connection with MAIN harness
G17	Ground

REAR HARNESS (RIGHT)

R15	Right front door switch
R16	Right rear wheel sensor
R17	Right rear door switch
R18	Rear power outlet
R25	Right rear combination lamp
DR02	Connection with REAR DOOR harness
MR03	Connection with MAIN harness
G18	Ground

TAIL GATE HARNESS (2)

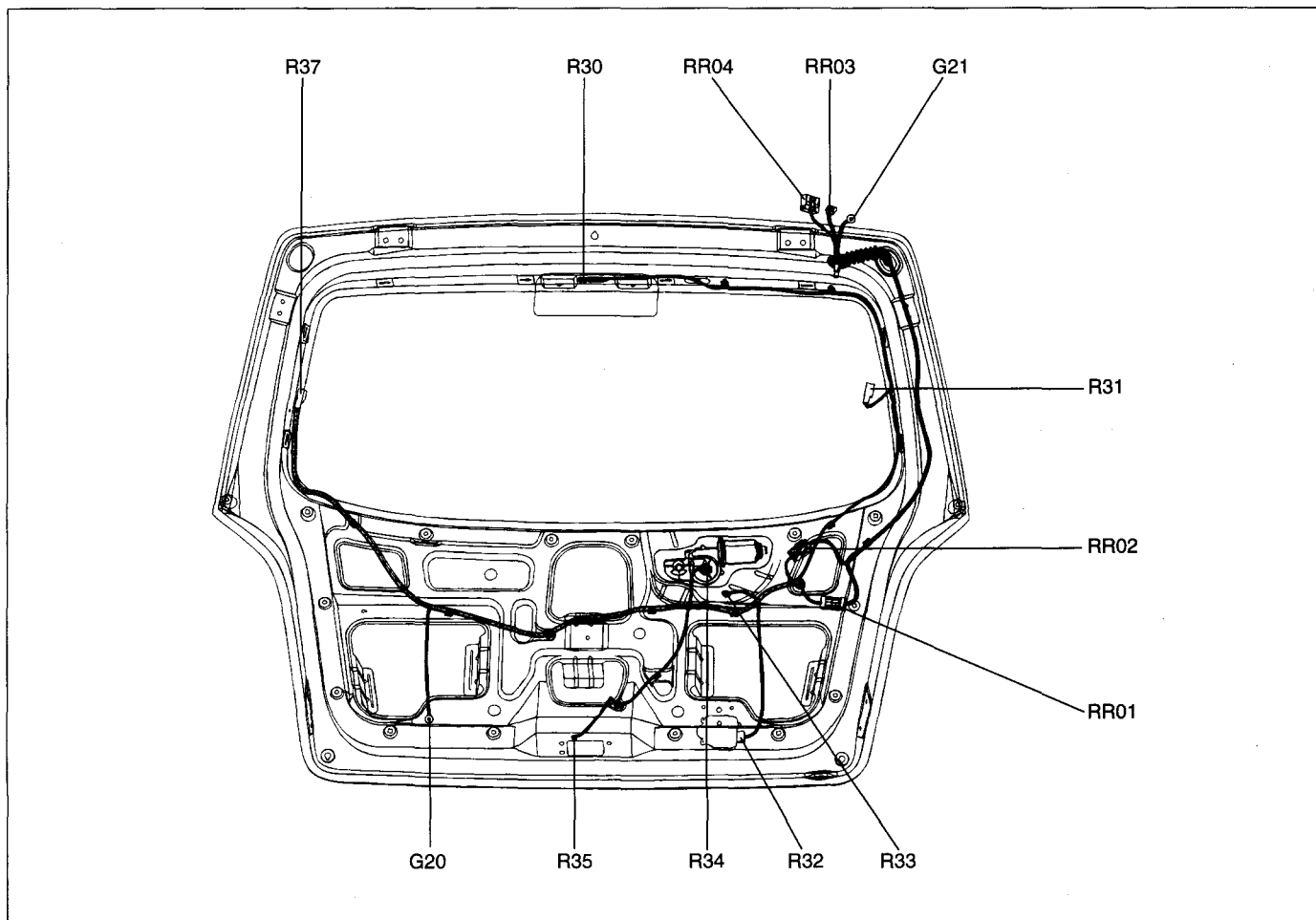

E5ME006B

TAIL GATE HARNESS

- R30 High-mounted stop lamp
- R31 Rear window defogger (+)
- R32 Tail gate lock actuator
- R33 License lamp
- R34 Rear wiper motor
- R35 Tail gate switch
- R37 Rear window defogger (-)
- RR01 Connection with TAIL GATE EXT. harness
- RR02 Connection with TAIL GATE EXT. harness
- G20 Ground

TAIL GATE EXT. HARNESS

- RR01 Connection with TAIL GATE harness
- RR02 Connection with TAIL GATE harness
- RR03 Connection with ROOF harness
- RR04 Connection with ROOF harness
- G21 Ground

ROOF HARNESS (3)

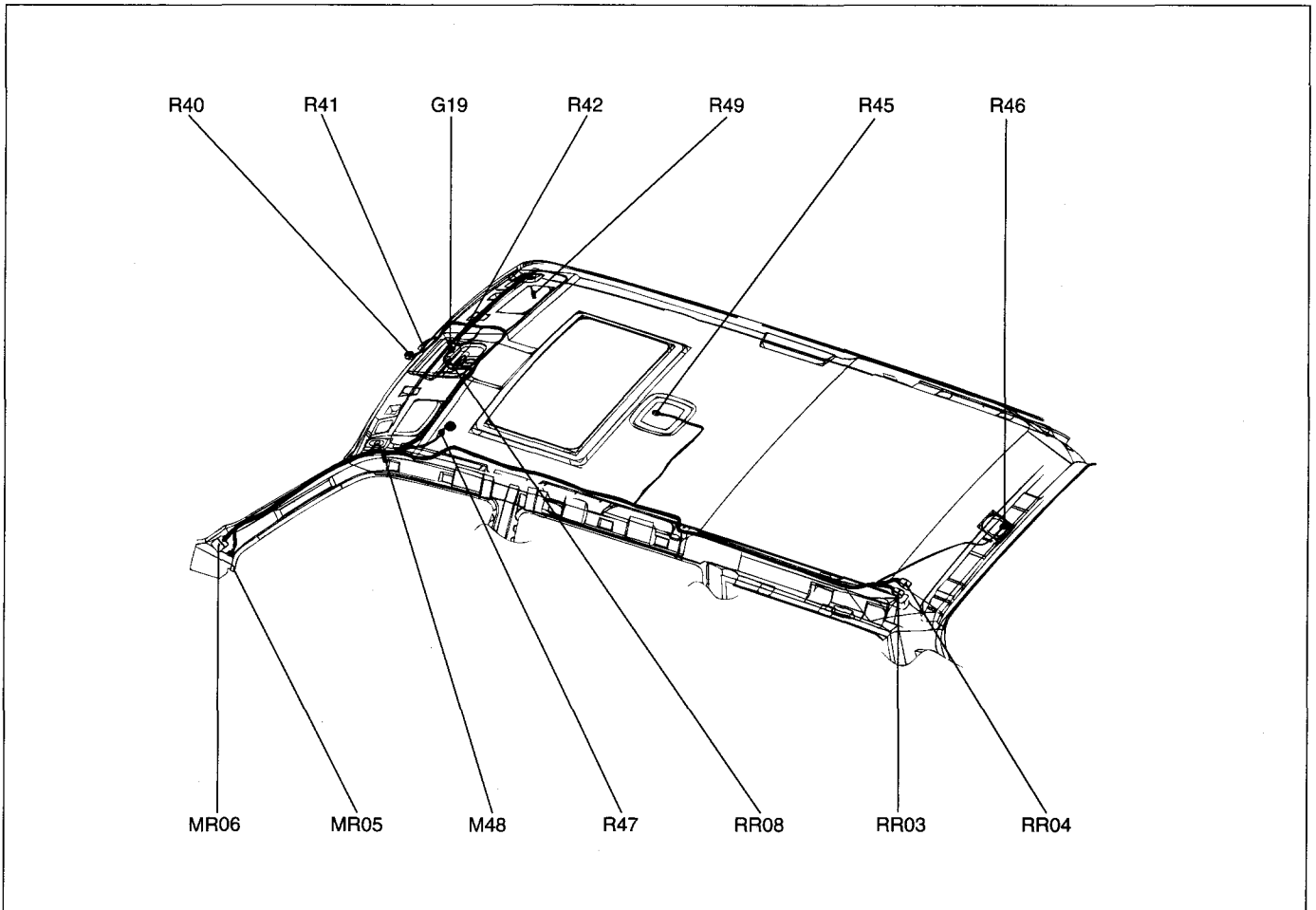

E5ME006C

ROOF HARNESS

R40	Inside mirror
R42	Overhead console lamp
R45	Room lamp
R46	Cargo lamp
MR05	Connection with MAIN harness
MR06	Connection with MAIN harness
RR03	Connection with TAIL GATE EXT. harness
RR04	Connection with TAIL GATE EXT. harness
RR08	Connection with SUNROOF harness
G19	Ground

SUNROOF HARNESS

R55	Overhead console
R56	Sunroof motor
R57-1	Sunroof controller
R57-2	Sunroof controller
RR08	Connection with ROOF harness

A/C & A/BAG HARNESS

EBE93B0B

A/C HARNESS (1)

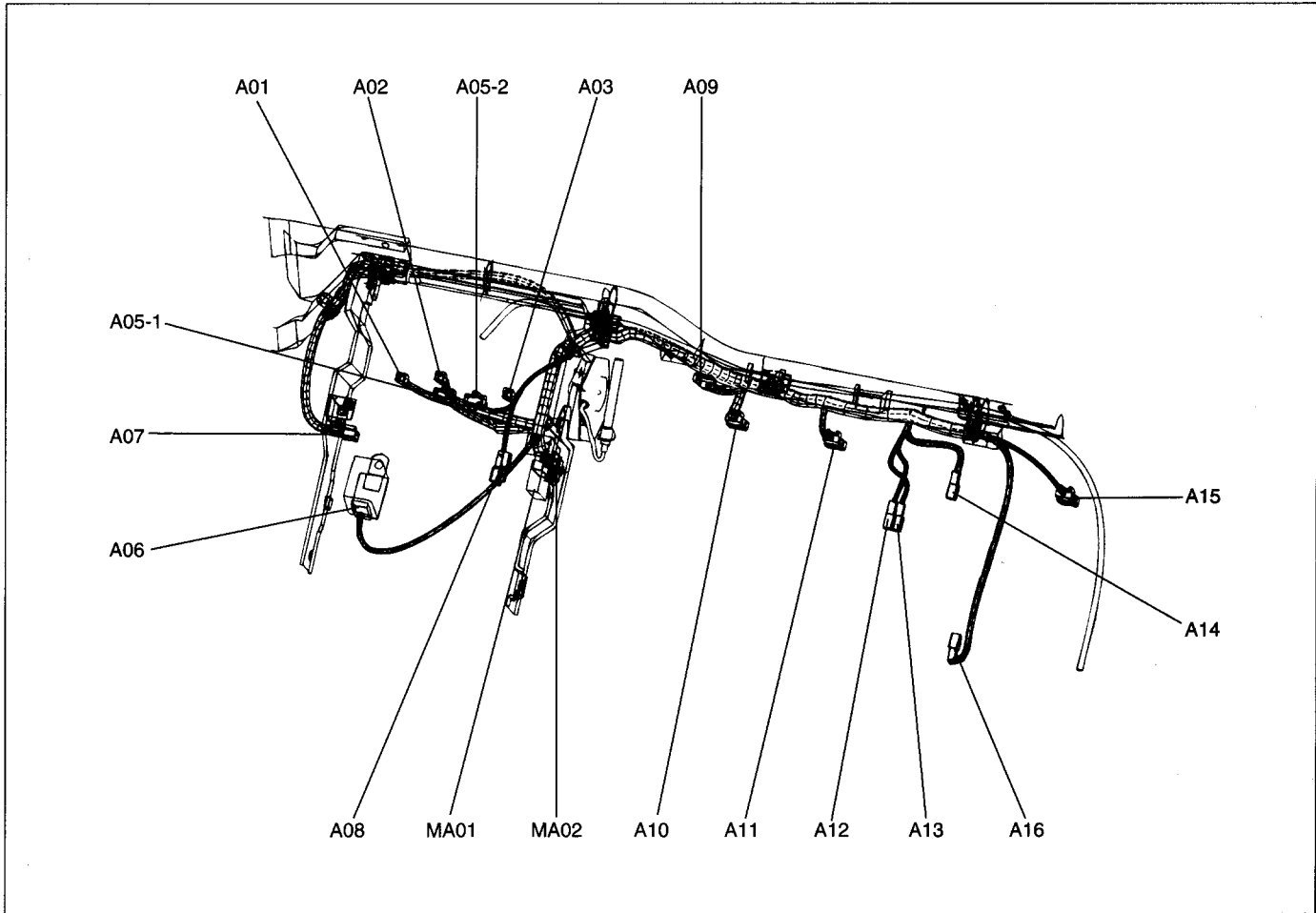

E5ME007A

A01	Blower switch (Manual A/C)	A11	Evaporator sensor (Auto A/C)
A02	A/C switch (Manual A/C)	A12	Power transistor (Auto A/C)
A03	Temperature switch (Manual A/C)	A13	Blower transistor (Manual A/C)
A05-1	A/C control module (Auto A/C)	A14	High blower relay (Auto A/C)
A05-2	A/C control module (Auto A/C)	A15	Intake actuator
A06	Blower relay	A16	Blower motor
A07	Mode actuator	MA01	Connection with MAIN harness
A08	Temperature actuator	MA02	Connection with MAIN harness
A09	Joint connector	Z04	Diode (Auto A/C)
A10	Thermostatic switch (Manual A/C)		

A/BAG HARNESS (2)

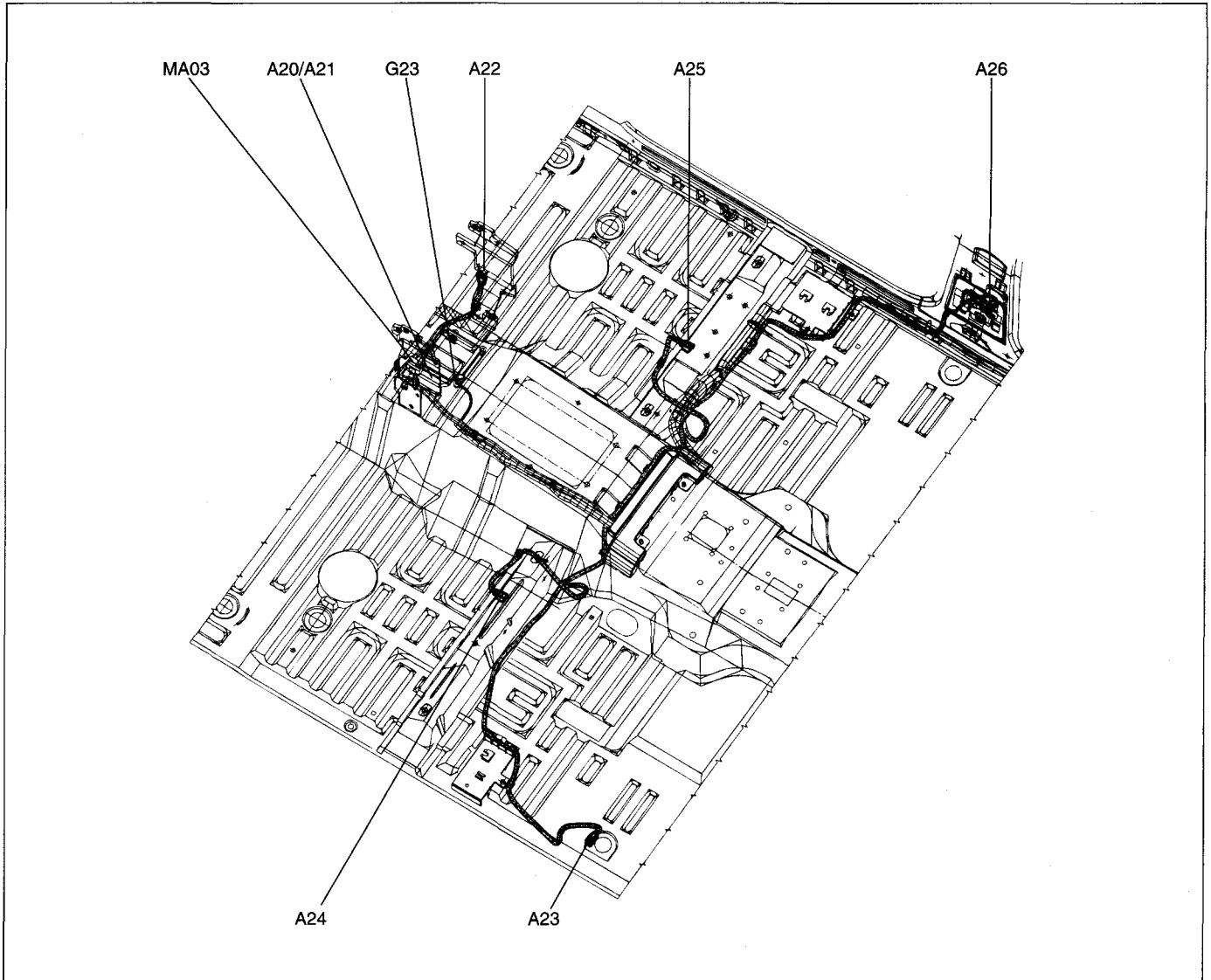

E5ME007B

A20	SRS control module (Dual A/Bag)	A25	Right seat buckle sensor
A21	SRS control module (Single A/Bag)	A26	Passenger seat belt pretensioner
A22	Passenger air bag	MA03	Connection with MAIN harness
A23	Driver seat belt pretensioner	G23	Ground
A24	Left seat buckle sensor		

SCHEMATIC DIAGRAMS

AIR BAG SYSTEM (SRS).....	SD-174
ANTI-LOCK BRAKE SYSTEM	SD-84
AUDIO SYSTEM.....	SD-138
AUTOMATIC TRANSAXLE CONTROL SYSTEM	SD-72
BACK-UP LAMPS	SD-160
BLOWER & A/C CONTROLS (AUTO)	SD-178
BLOWER & A/C CONTROLS (MANUAL)	SD-184
CHARGING SYSTEM	SD-40
CIGARETTE LIGHTER (POWER OUTLET)	SD-92
COOLING SYSTEM	SD-44
COURTESY & TAIL GATE LAMPS	SD-164
CRUISE CONTROL SYSTEM.....	SD-176
DATA LINK DETAILS	SD-28
DAYTIME RUNNING LIGHTS	SD-144
DIGITAL CLOCK.....	SD-94
ELECTRONIC CHROME MIRROR.....	SD-126
ETACS (ELECTRONIC TIME & ALARM CONTROL SYSTEM)	SD-96
FRONT FOG & REAR FOG LAMPS	SD-154
FRONT WIPER & WASHER.....	SD-100
FUEL HEATER CONTROL SYSTEM	SD-70
FUSE & RELAY INFORMATION.....	SD-2
GROUND DISTRIBUTION	SD-20
HEAD LAMP LEVELING DEVICE	SD-148
HEAD LAMPS	SD-142
HORNS	SD-140
ILLUMINATIONS	SD-168
IMMOBILIZER CONTROL SYSTEM	SD-88
INDICATORS & GAUGES	SD-108
KEYLESS ENTRY & BURGLAR ALARM CONTROL SYSTEM.....	SD-104
MFI CONTROL SYSTEM (COVEC-F)	SD-48
MFI CONTROL SYSTEM (2.9TCI)	SD-56
MFI CONTROL SYSTEM (GASOLINE)	SD-62
MFI CONTROL/ AUTOMATIC TRANSAXLE CONTROL SYSTEM	SD-189
(FULL CIRCUIT DIAGRAM)	
MULTIMETER.....	SD-116
PASSENGER COMPARTMENT FUSE DETAILS.....	SD-16
POWER DISTRIBUTION	SD-8
POWER DOOR LOCKS	SD-118
POWER OUTSIDE MIRRORS	SD-122
POWER SEAT	SD-128
POWER WINDOWS	SD-132
REAR WINDOW & OUTSIDE MIRROR DEFOGGER SYSTEM	SD-124
REAR WIPER & WASHER	SD-102
SEAT WARMER	SD-130
STARTING SYSTEM	SD-34
STOP LAMPS.....	SD-162
SUNROOF	SD-136
TAIL, PARKING & LICENSE LAMPS	SD-158
TCCS (EST).....	SD-80
TCCS (TOD)	SD-76
TURN & HAZARD LAMPS	SD-150
VEHICLE SPEED SENSOR	SD-32

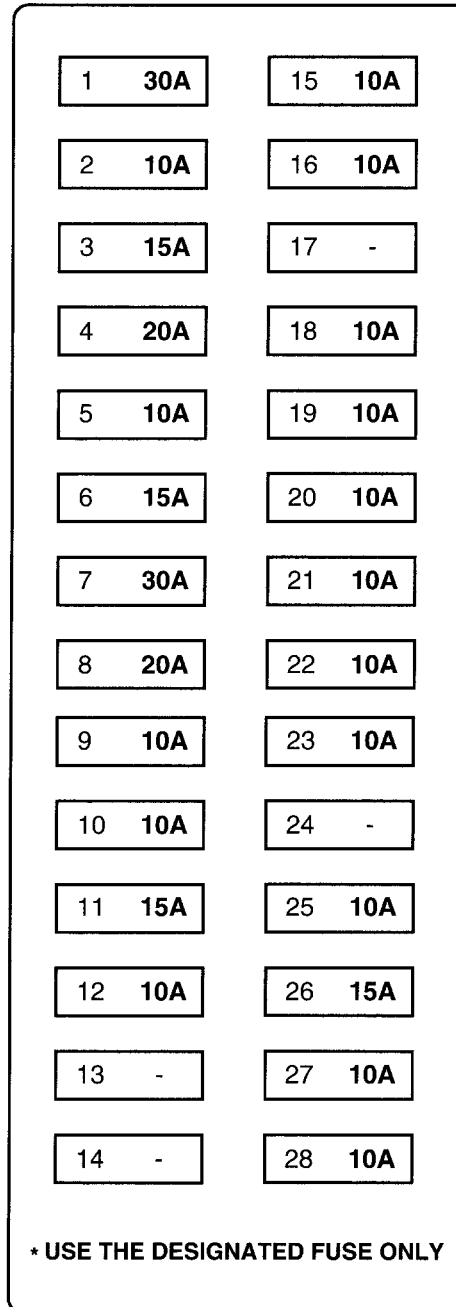

FUSE & RELAY INFORMATION EDC20C5D**PASSENGER COMPARTMENT FUSE BOX****LAYOUT**

CIRCUIT

NO	Amperage (A)	Circuit protected
1	30A	Defogger
2	10A	Hazard relay, Hazard
3	15A	Stop lamps
4	20A	Transfer (TOD control module, EST control module)
5	10A	-
6	15A	Sunroof
7	30A	Blower relay
8	20A	Power door locks
9	10A	Rear fog lamp relay
10	10A	Audio, Overhead console lamp
11	15A	Cigarette lighter, Power outlet
12	10A	Outside mirror
13	-	-
14	-	-
15	10A	A/C switch
16	10A	Left/Right outside mirror motor & defogger
17	-	-
18	10A	TCM, ECM(COVEC-F), TCCS(TOD, EST), Immobilizer
19	10A	Back-up lamp, Inside mirror, Transaxle range switch
20	10A	Hazard switch
21	10A	Instrument cluster, ETACM, Vehicle speed sensor, DRL control module
22	10A	Air bag
23	10A	Air bag IND.
24	-	-
25	10A	Blower & A/C, ETACM, Defogger relay
26	15A	Seat warmer
27	10A	Sunroof, Rear wiper & washer, Cruise switch
28	10A	Start relay, Burglar alarm relay

*** USE THE DESIGNATED FUSE ONLY**

ENGINE COMPARTMENT FUSE & RELAY BOX #1

LAYOUT

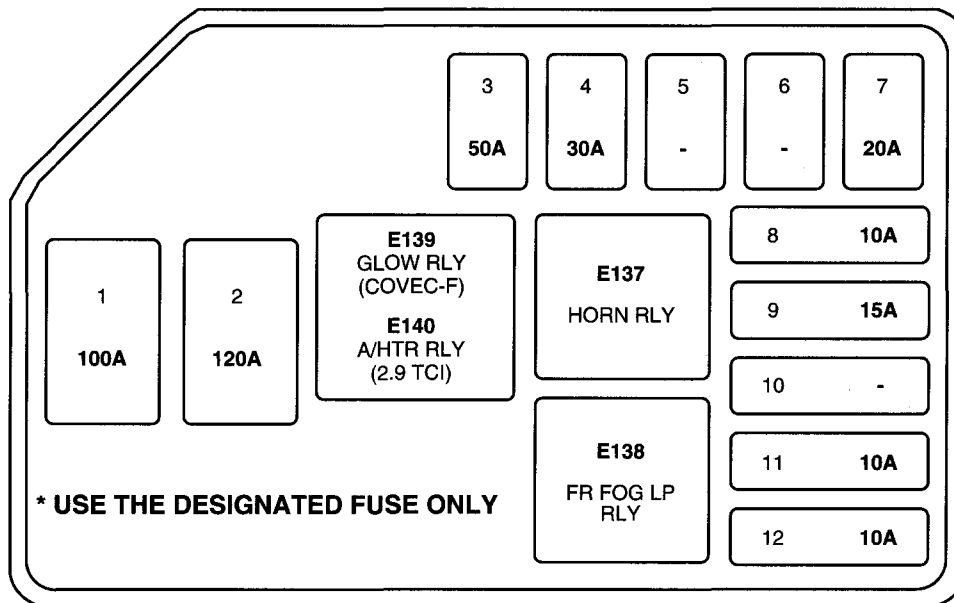

CIRCUIT

	NO	Amperages(A)	Circuit protected
FUSIBLE LINK	1	100A	Glow relay (COVEC-F), Air heater relay (2.9 TCI)
	2	120A	Engine compartment fuse & relay box #2, Generator
	3	50A	Passenger compartment fuse box (1,2,3,4,5), Engine compartment fuse & relay box #1 (8,9), Fuel heater control module (COVEC-F)
	4	30A	Generator, Ignition switch
	5	-	-
	6	-	-
	7	20A	Engine control relay (Diesel/Gasoline)
FUSE	8	10A	Horn relay
	9	15A	Front fog lamp
	10	-	-
	11	10A	ECM (Diesel)
	12	10A	ECM (2.9 TCI)

ENGINE COMPARTMENT FUSE & RELAY BOX #2

LAYOUT

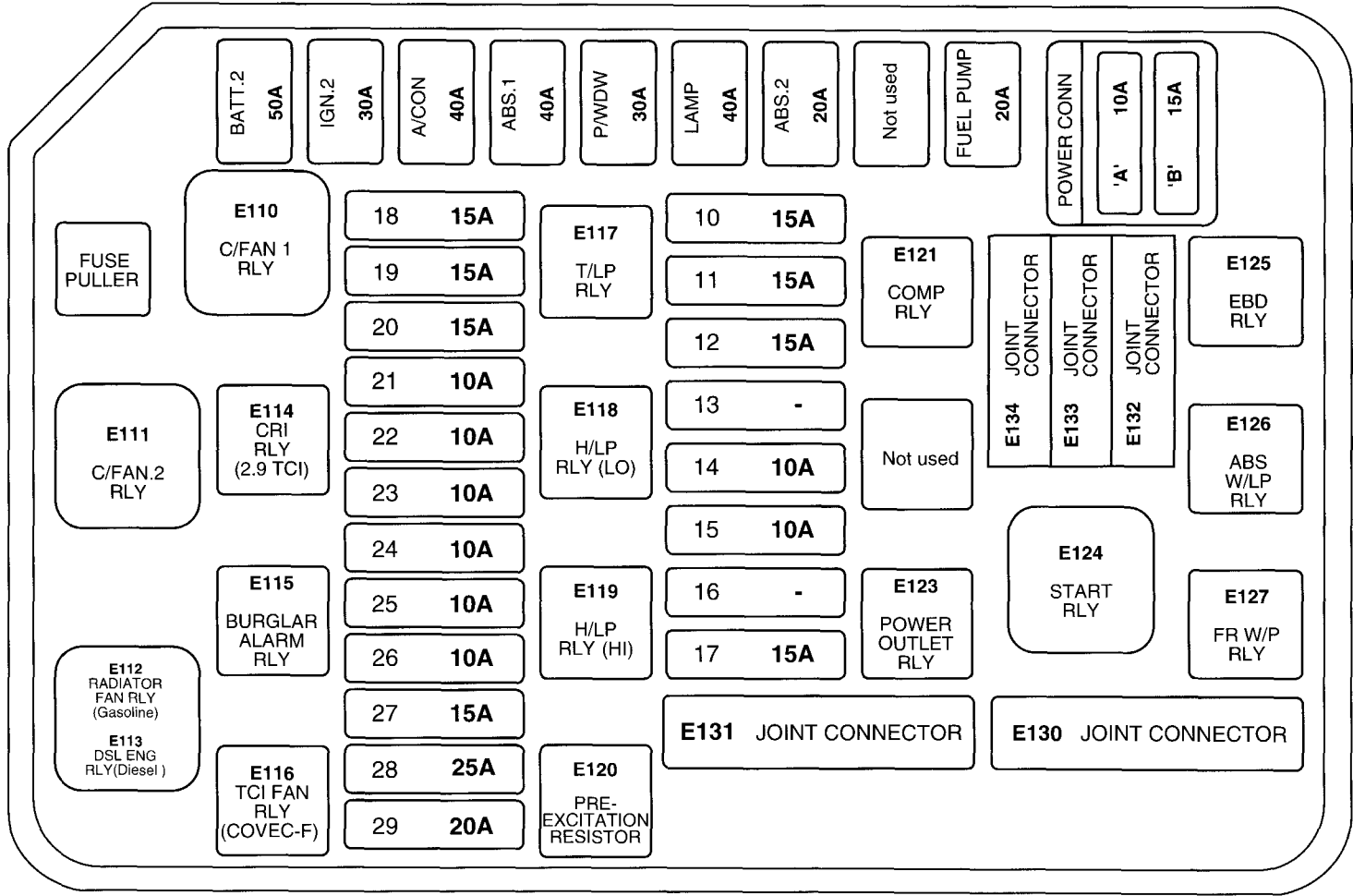

CIRCUIT

	NO	Amperages(A)	Circuit Protected
FUSE	10	15A	Fuel heater & sensor(2.9 TCI)
	11	15A	Head lamp relay(Low)
	12	15A	Head lamp relay(High)
	13	-	-
	14	10A	A/C compressor relay, Triple switch(Gasoline)
	15	10A	TCI fan relay(COVEC-F)
	16	-	-
	17	15A	-
	18	15A	ECM(Diesel)
	19	15A	ECM(Diesel)
	20	15A	ECM(2.9 TCI), Air heater relay (2.9 TCI), Inlet metering valve(2.9 TCI), EGR solenoid(2.9 TCI)
	21	10A	Illuminations,combination lamp
	22	10A	License lamp,combination lamp
	23	10A	ABS control module, ABS relay, EBD relay
	24	10A	ECM(Diesel), Head lamp relay, Condenser fan relay(Gasoline/COVEC-F), EGR solenoid(COVEC-F), Engine control relay(COVEC-F), Water level switch (2.9 TCI)
	25	10A	ABS control module
	26	10A	Cruise control module
	27	15A	Front wiper & washer
	28	25A	Power seat switch
29	20A	Power outlet relay	
FUSIBLE LINK	BATT.2	50A	Power connector(A,B), Engine compartment fuse & relay box #2 (Fuse 28,29), Passenger compartment fuse box (Fuse 6,7,8,9)
	IGN.2	30A	Start relay, Ignition switch
	A/CON	40A	A/C relay, Condenser fan relay Engine compartment fuse & relay box #2 (Fuse 14,15)
	ABS.1	40A	ABS control module
	P/WDW	30A	Power window relay
	LAMP	40A	Tail lamp relay, Engine compartment fuse & relay box #2 (Fuse 11,12)
	ABS.2	20A	ABS control module
	FUEL PUMP	20A	Fuel pump relay, ECM, Ignition failure sensor
POWER CONNECTOR.A	10A	A/CON, TCM, ETACM, Data link connector, Siren, Immobilizer control module	
POWER CONNECTOR.B	15A	Courtesy lamps, Overhead console lamp, Audio, Instrument cluster, Front door lamp	

*** USE THE DESIGNATED FUSE ONLY**

PASSENGER COMPARTMENT RELAY BOX

LAYOUT

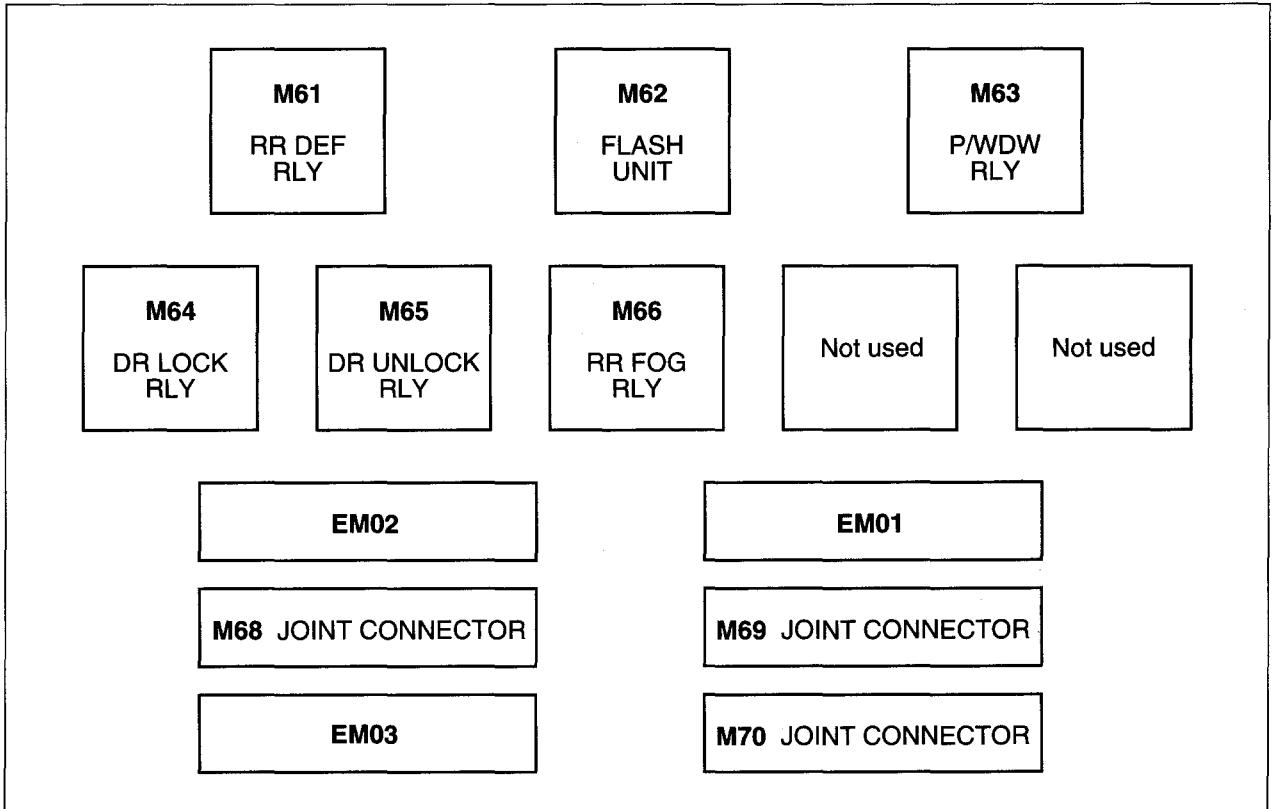

POWER DISTRIBUTION

E14C81FA

POWER DISTRIBUTION (1)

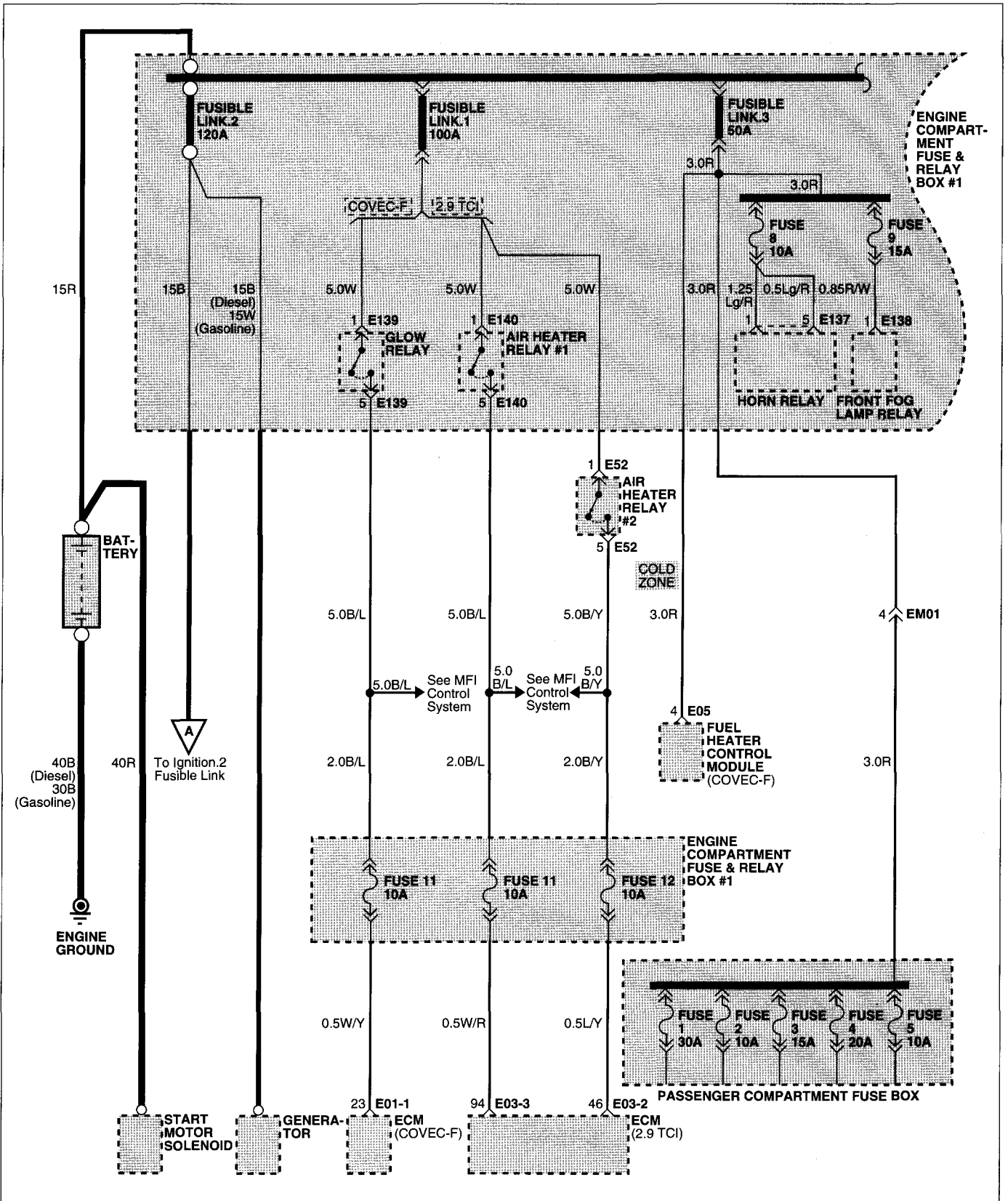

POWER DISTRIBUTION (2)

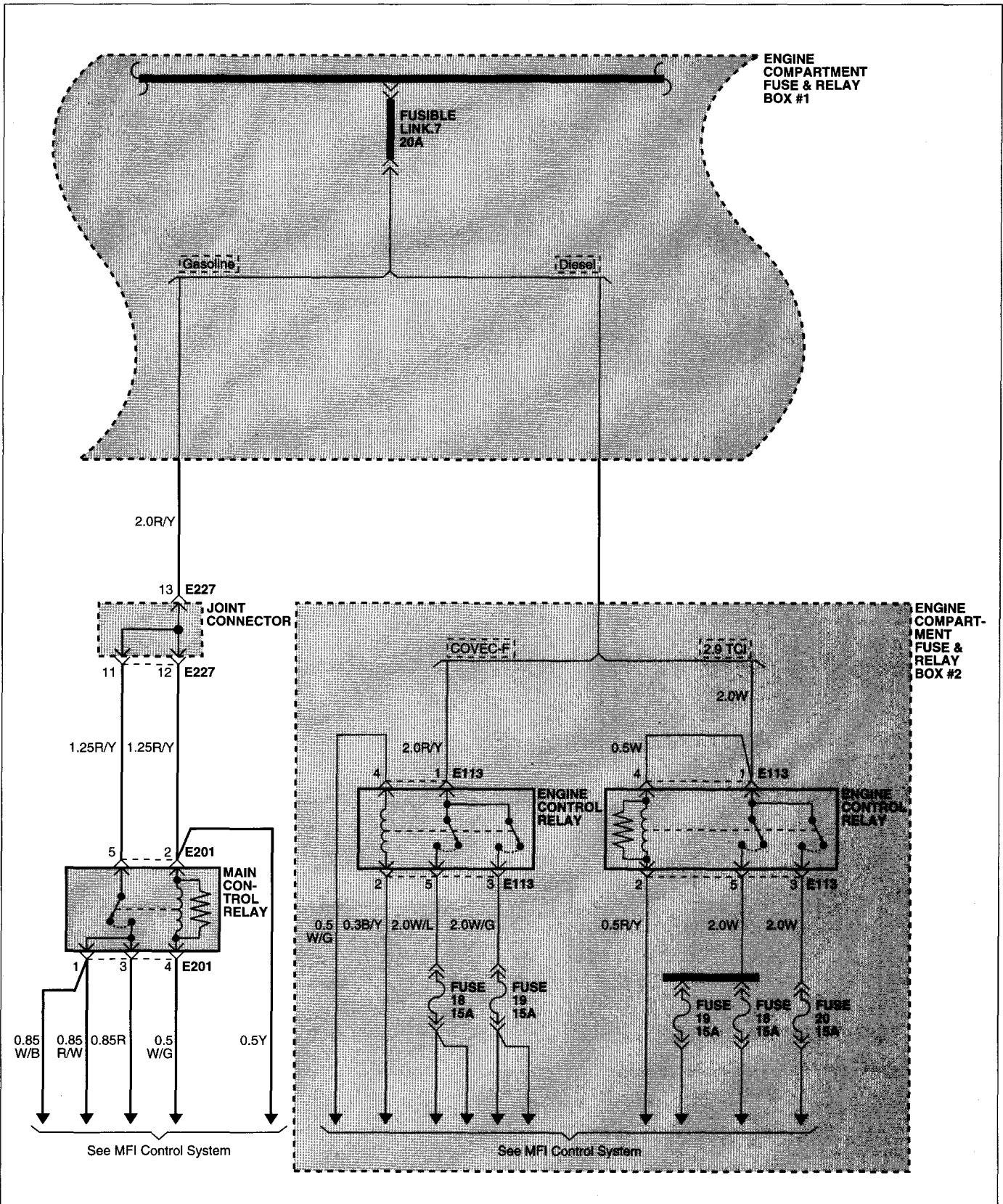

POWER DISTRIBUTION (3)

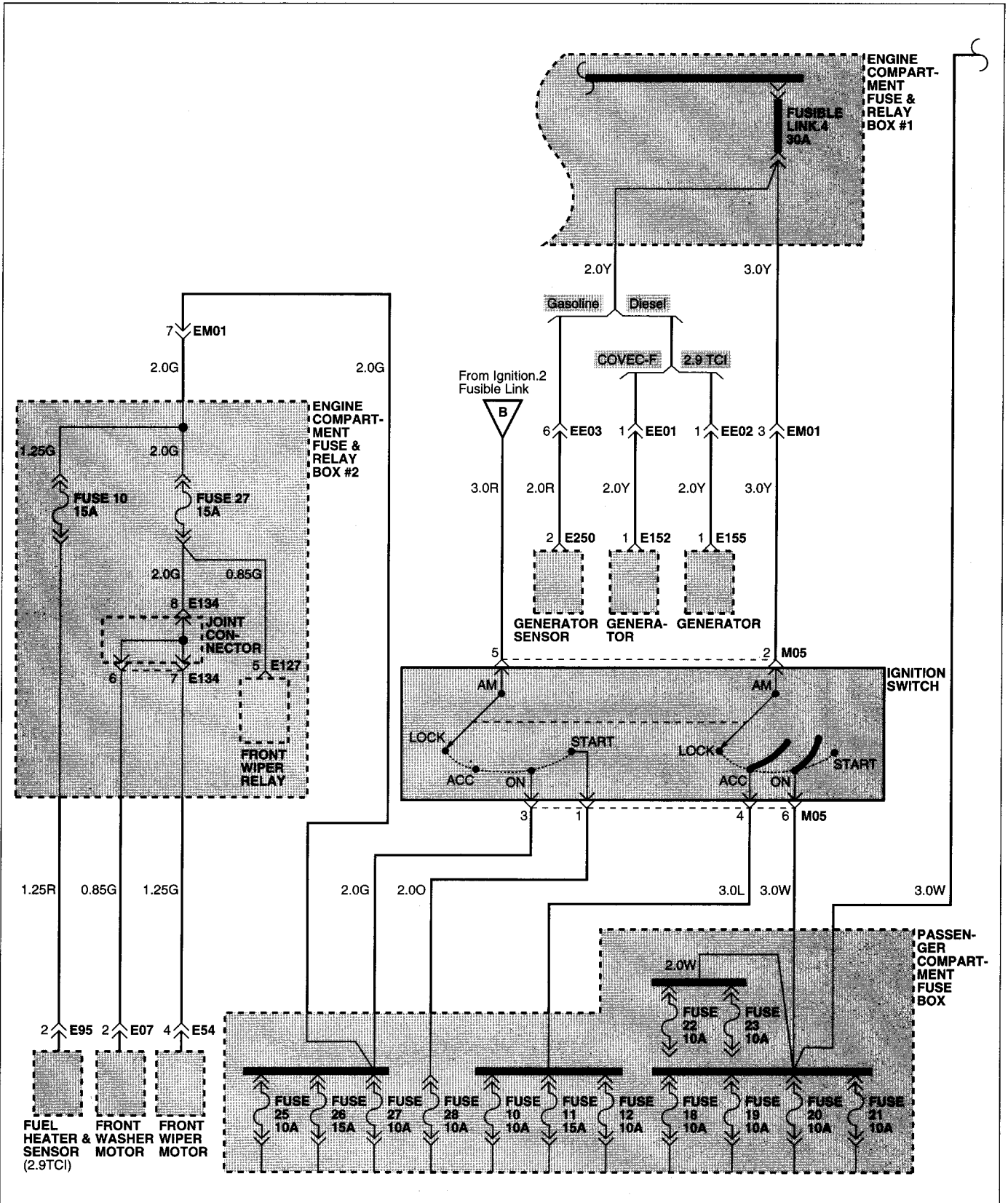

POWER DISTRIBUTION (4)

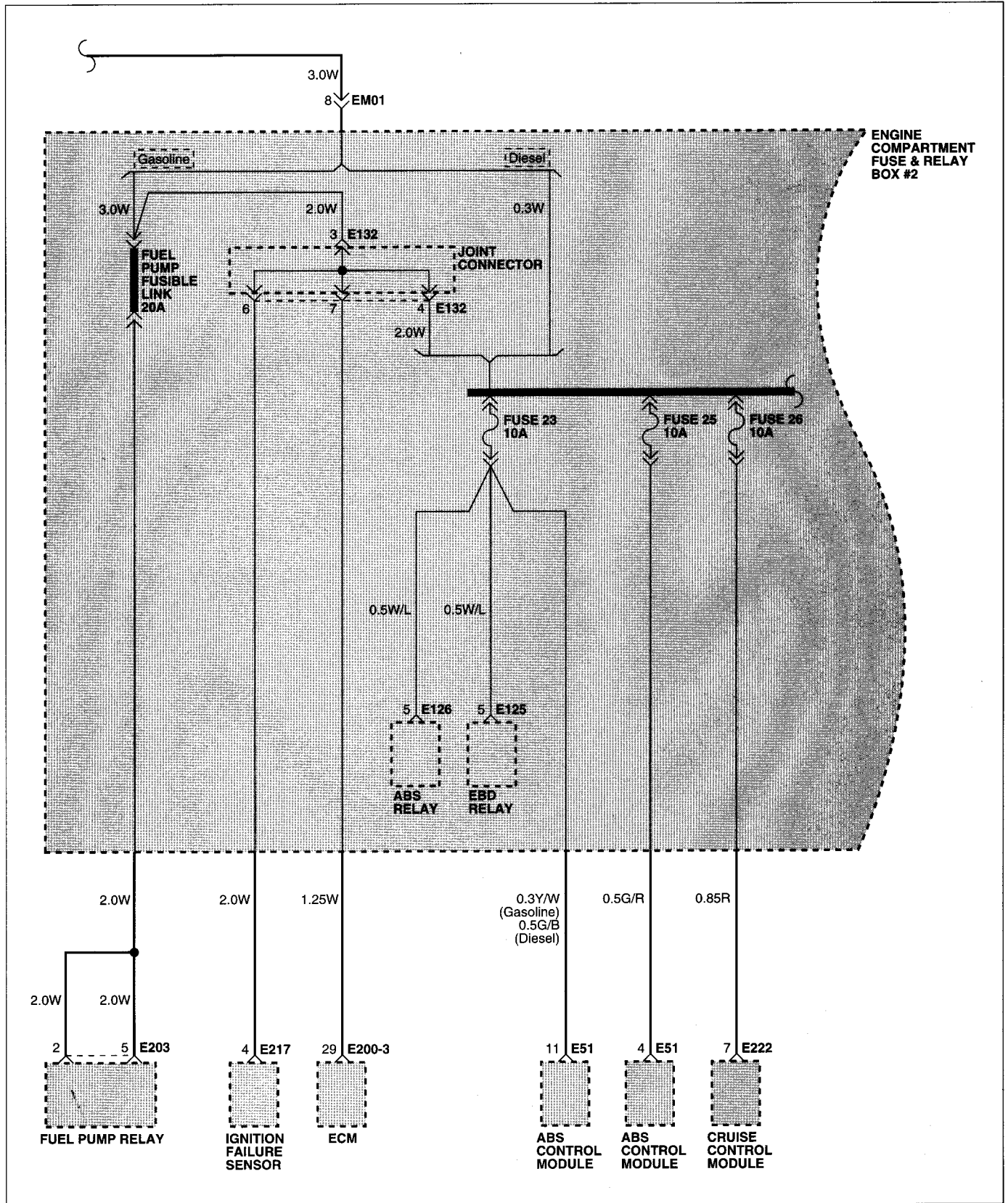

POWER DISTRIBUTION (5)

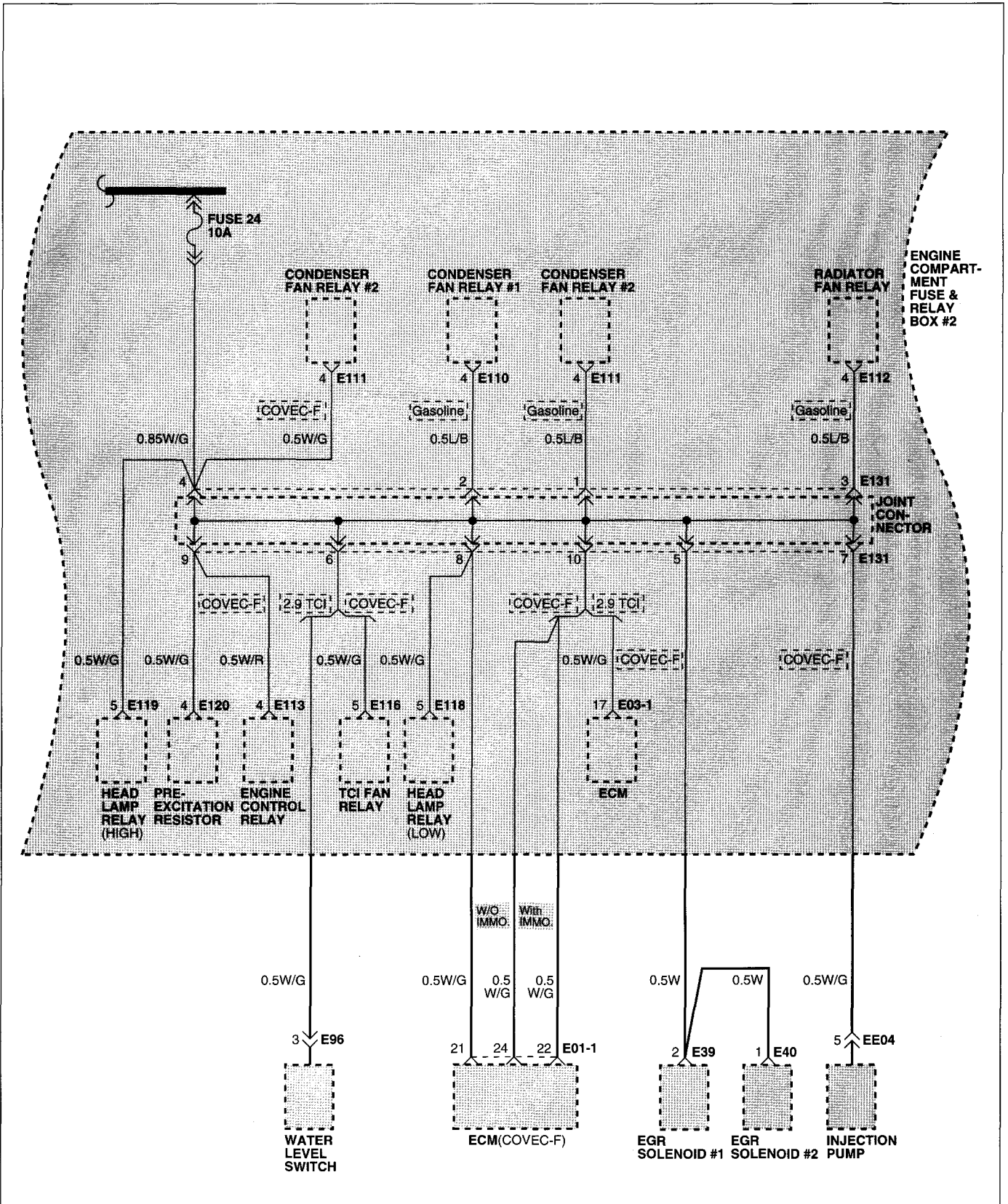

POWER DISTRIBUTION (6)

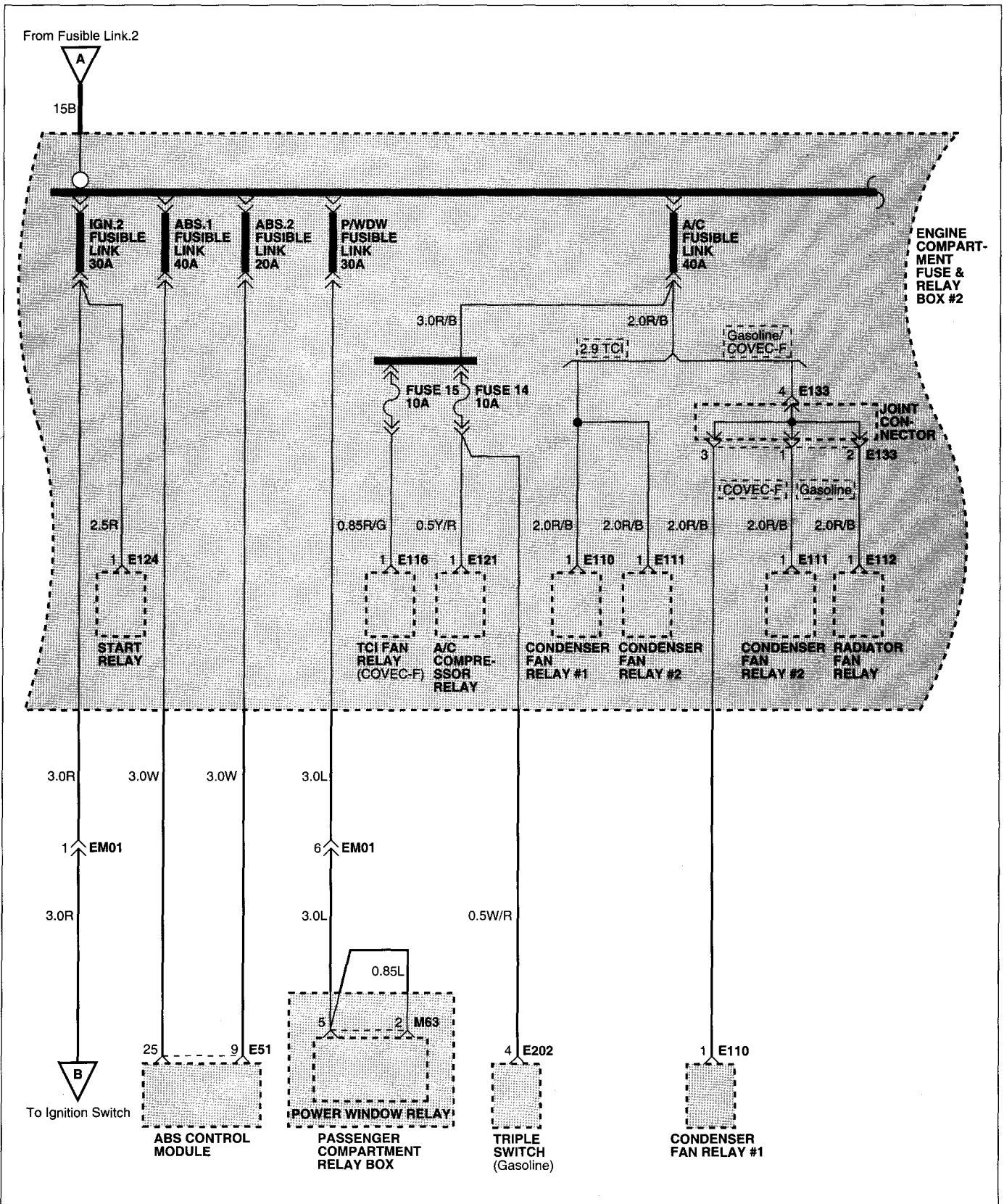

POWER DISTRIBUTION (7)

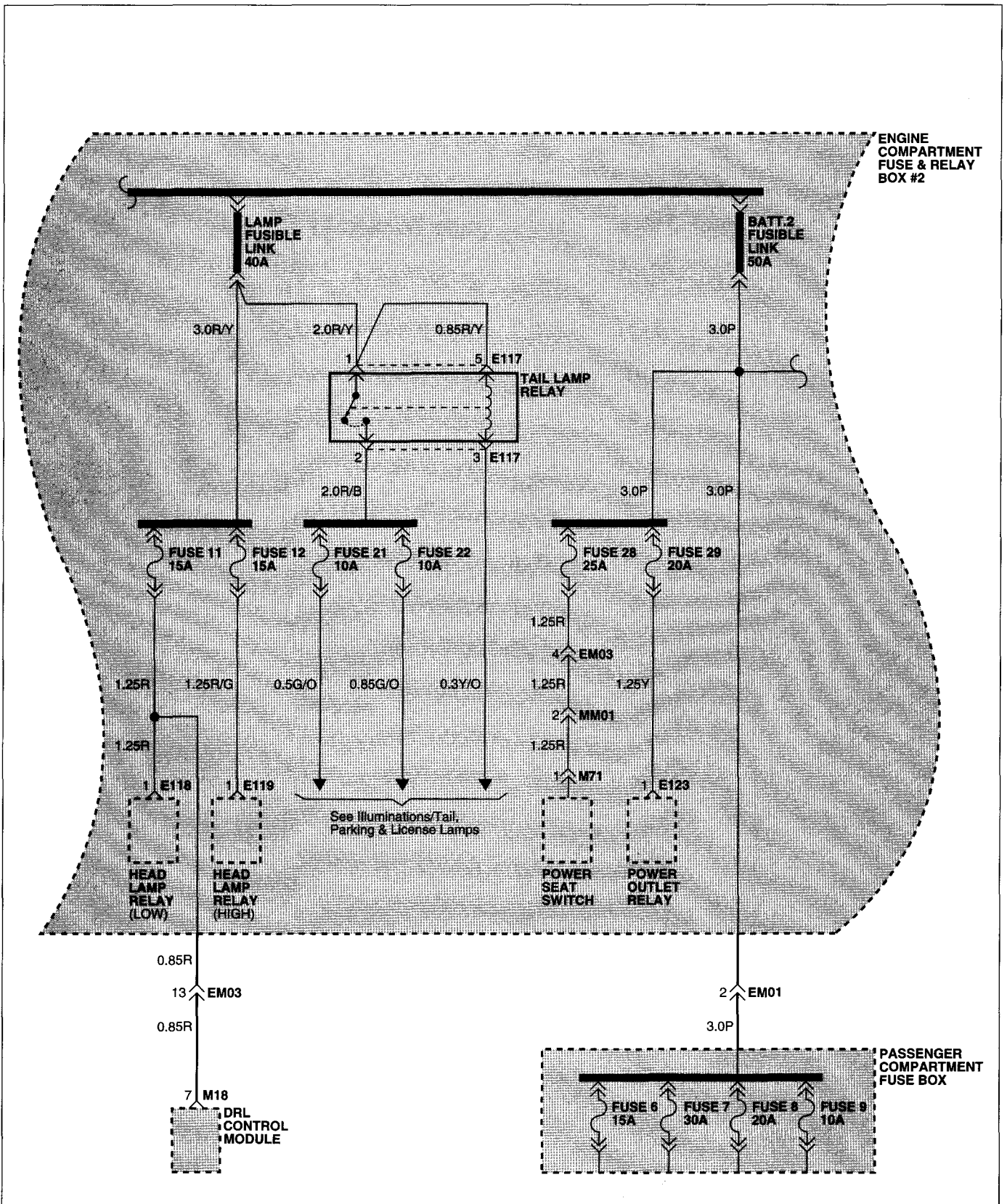

POWER DISTRIBUTION (8)

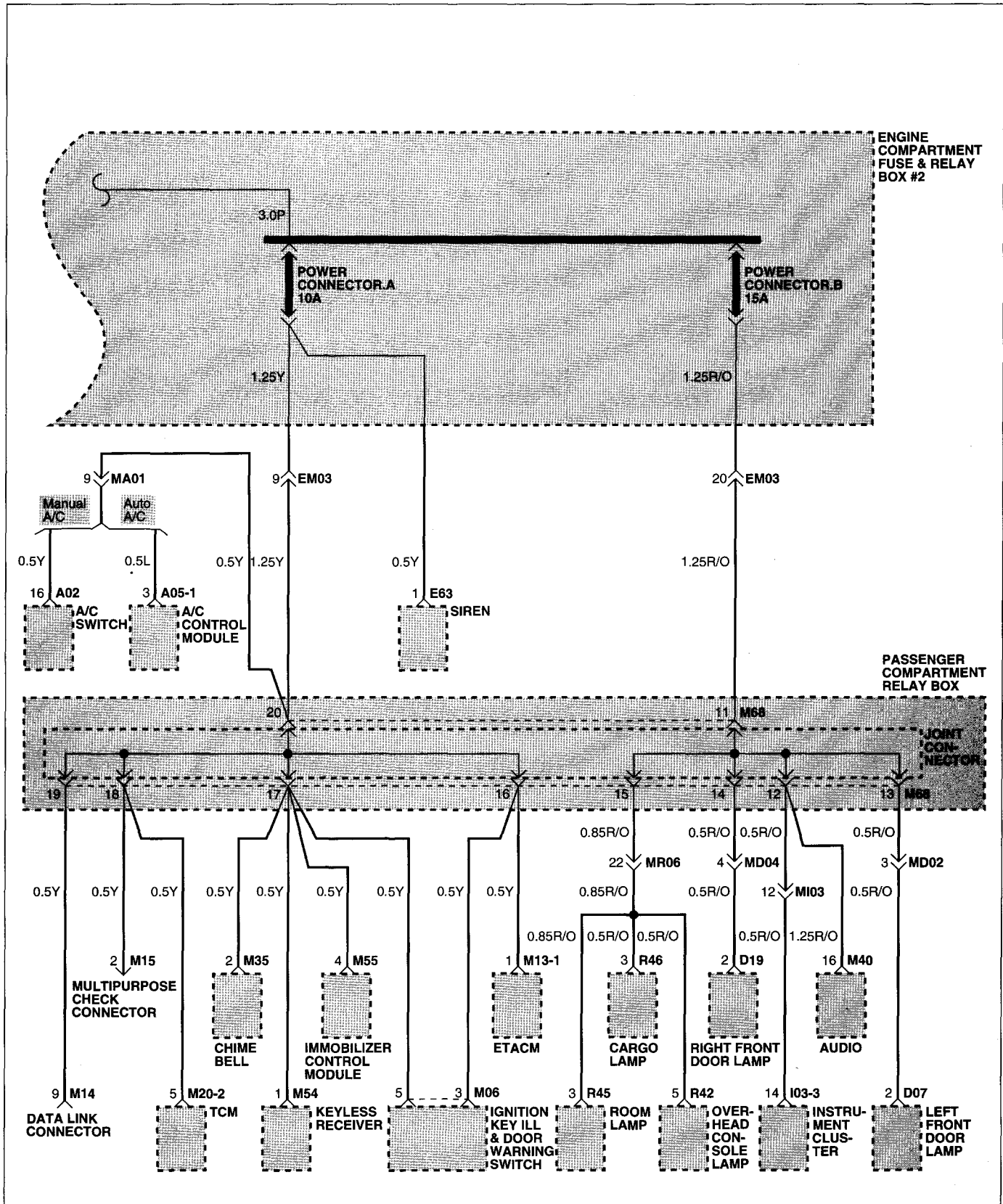

PASSENGER COMPARTMENT FUSE DETAILS

E0DAFDBF

PASSENGER COMPARTMENT FUSE DETAILS (1)

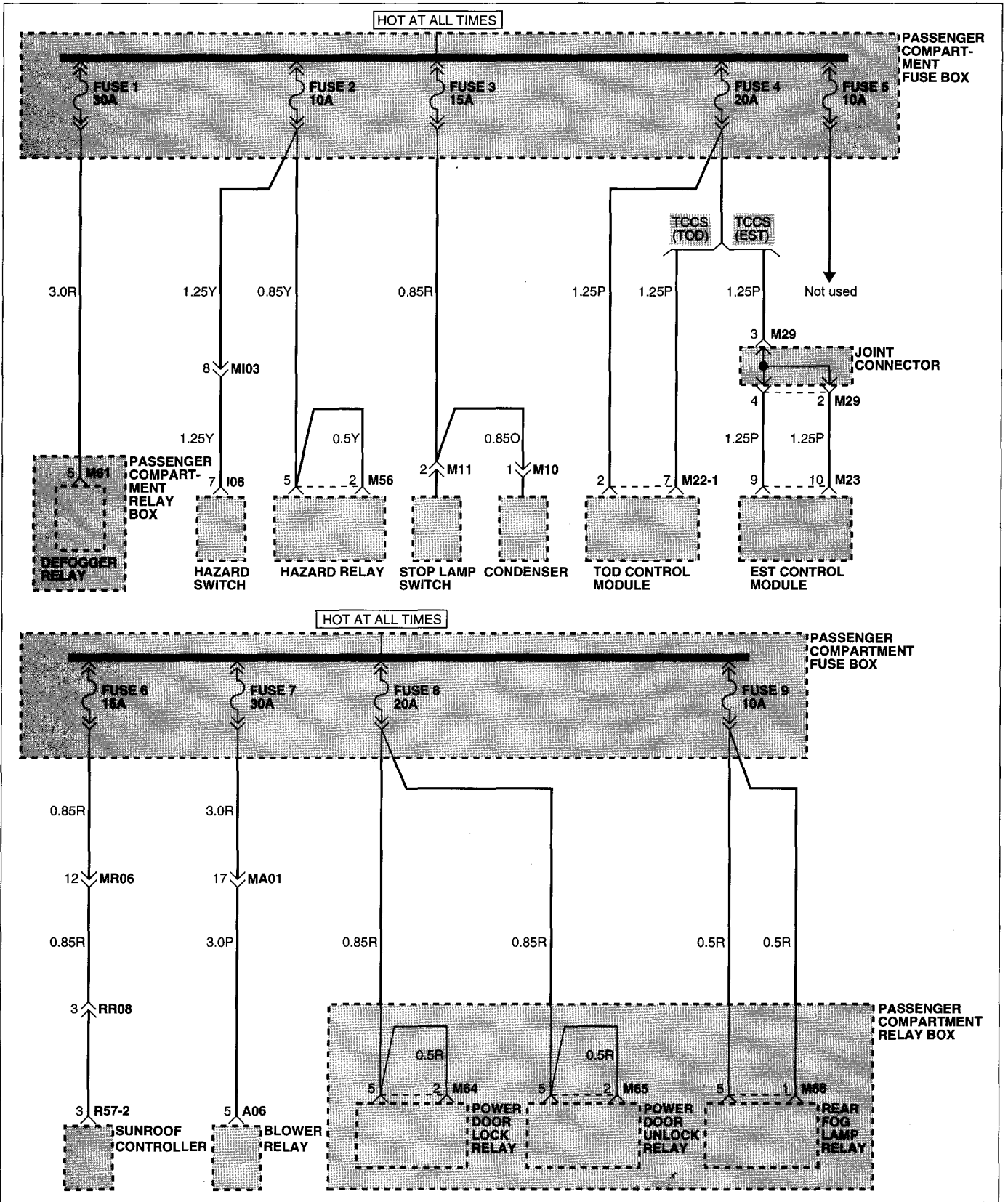

PASSENGER COMPARTMENT FUSE DETAILS (2)

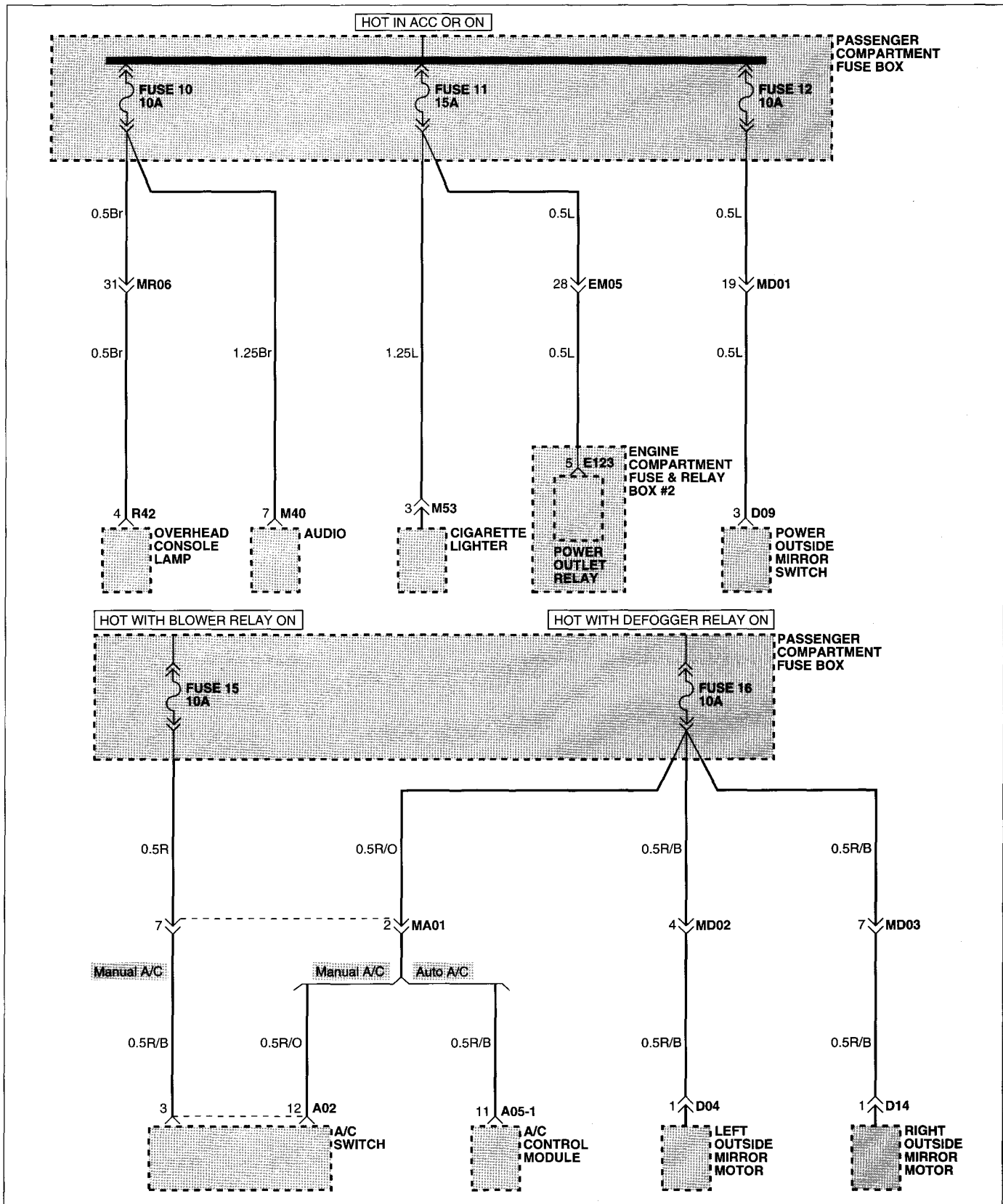

PASSENGER COMPARTMENT FUSE DETAILS (3)

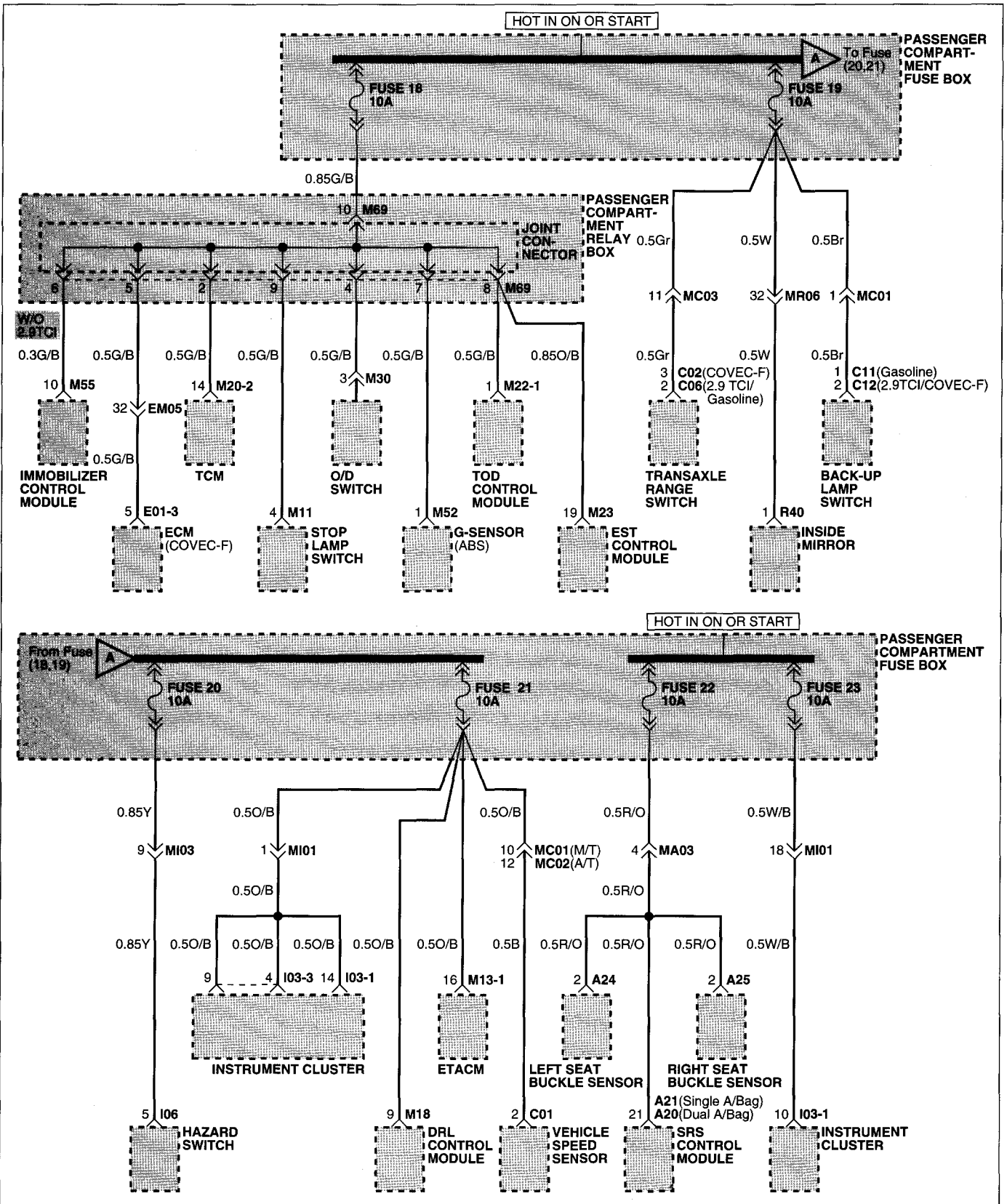

PASSENGER COMPARTMENT FUSE DETAILS (4)

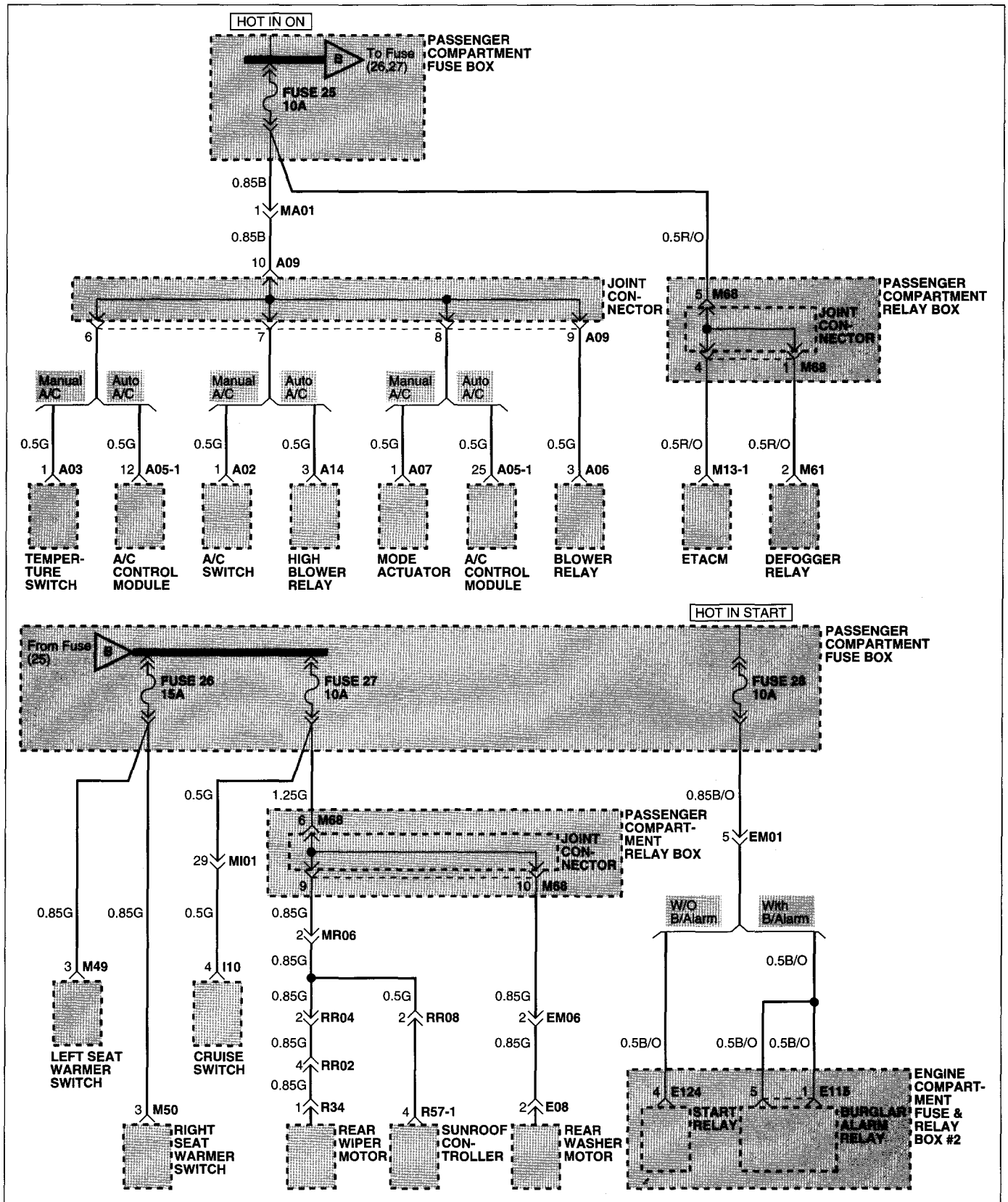

GROUND DISTRIBUTION

E4B1126C

GROUND DISTRIBUTION (1)

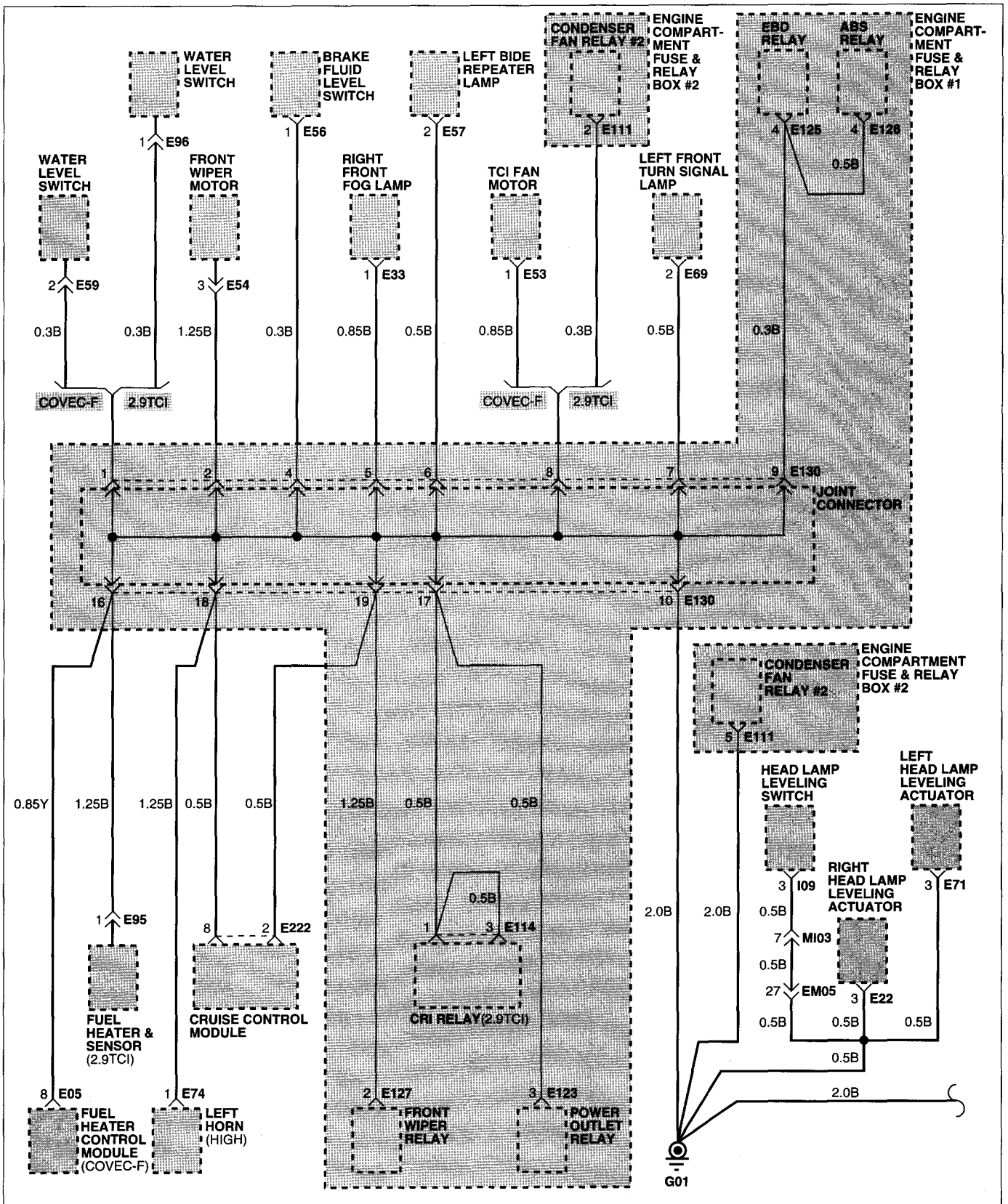

GROUND DISTRIBUTION (2)

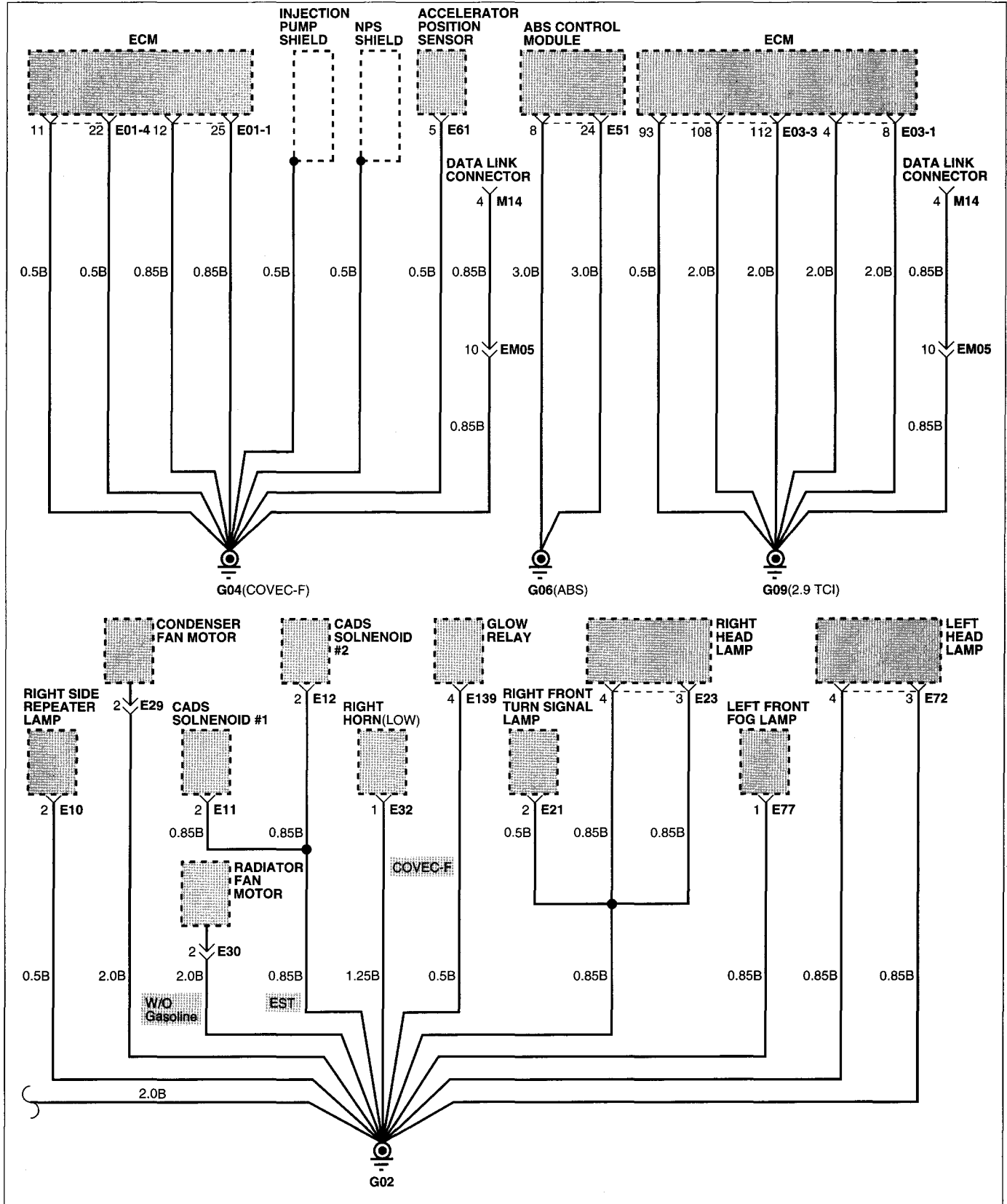

GROUND DISTRIBUTION (3)

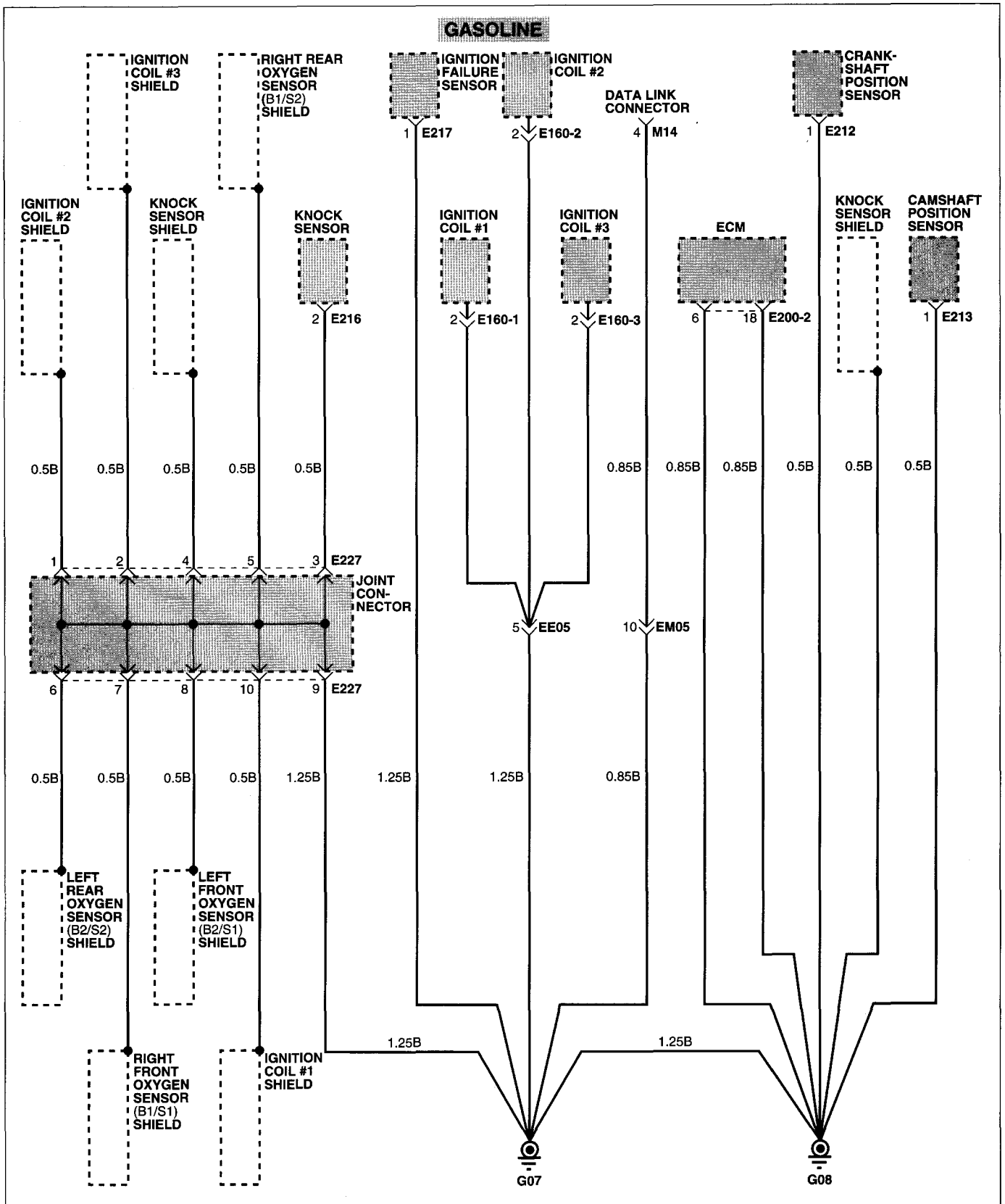

GROUND DISTRIBUTION (4)

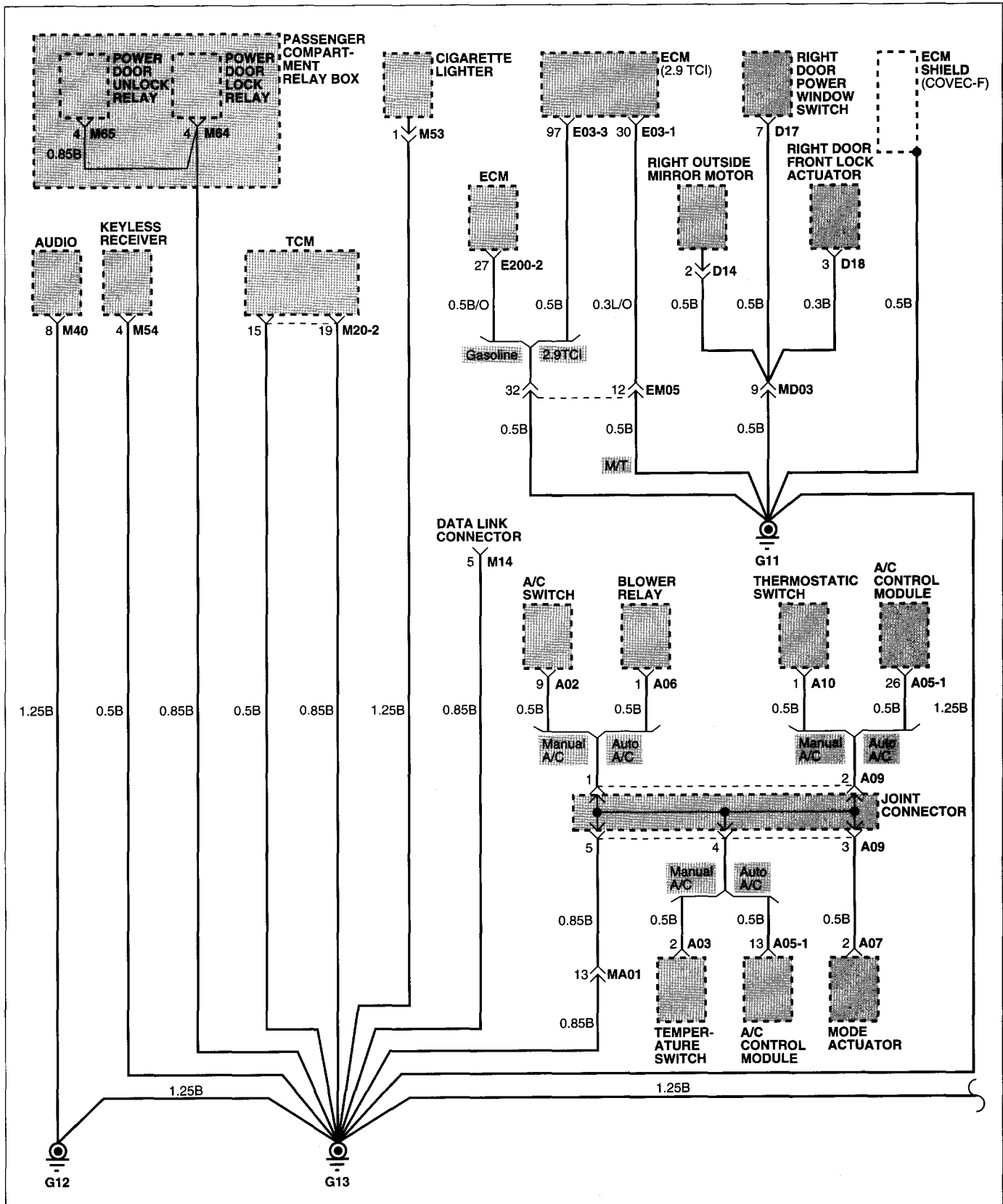

GROUND DISTRIBUTION (5)

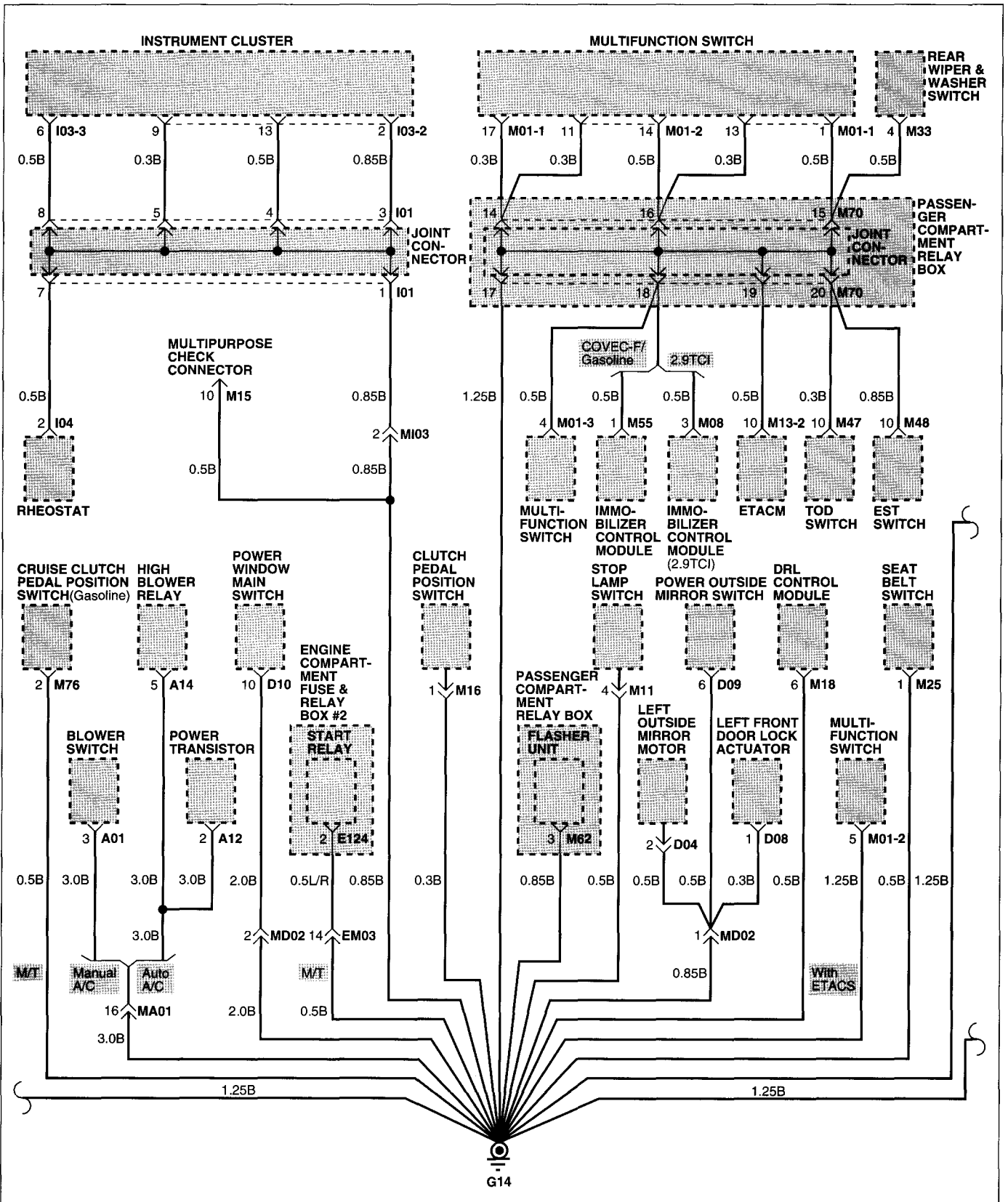

GROUND DISTRIBUTION (6)

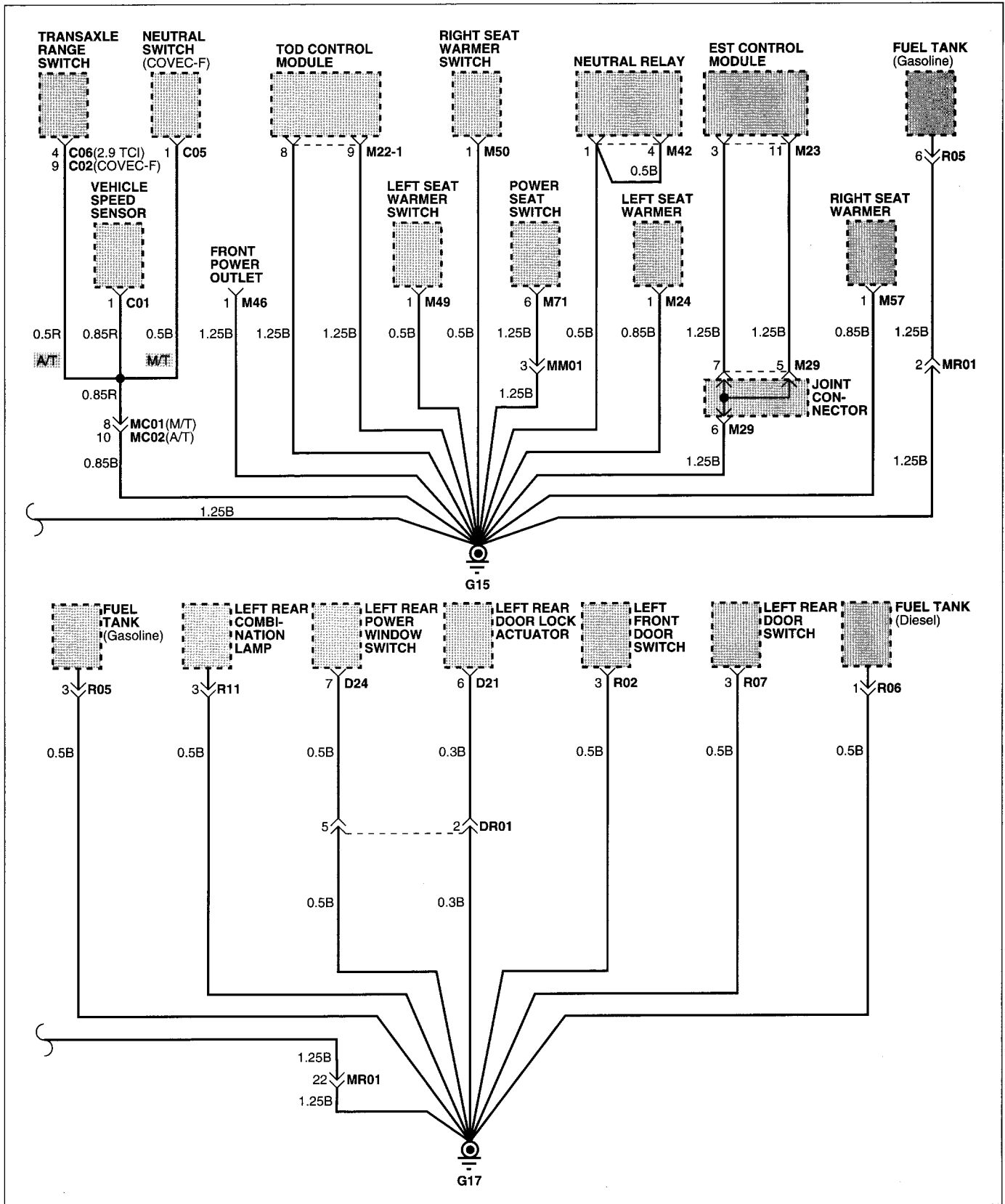

GROUND DISTRIBUTION (7)

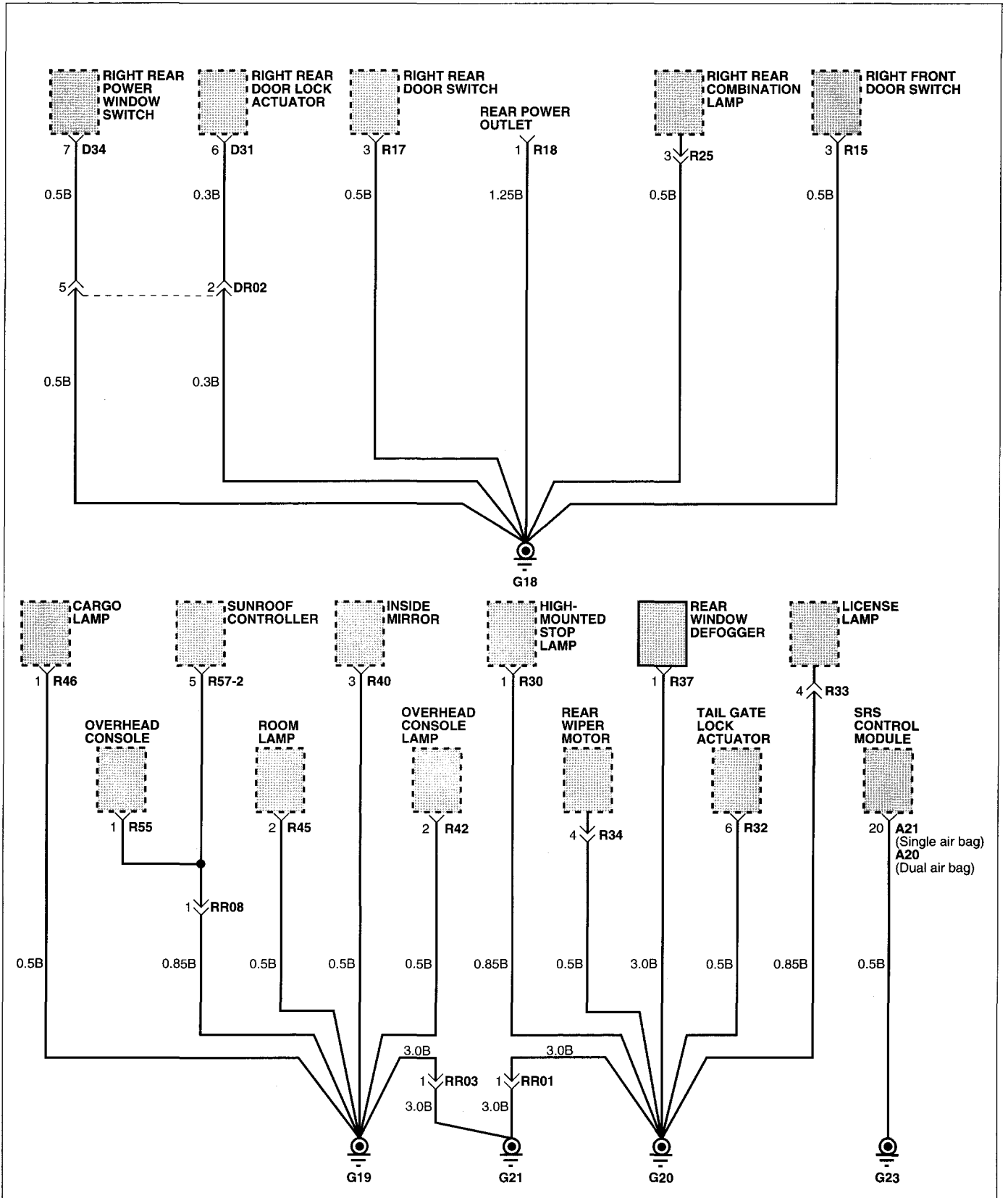

DATA LINK DETAILS EB6237D6

DATA LINK DETAILS (1)

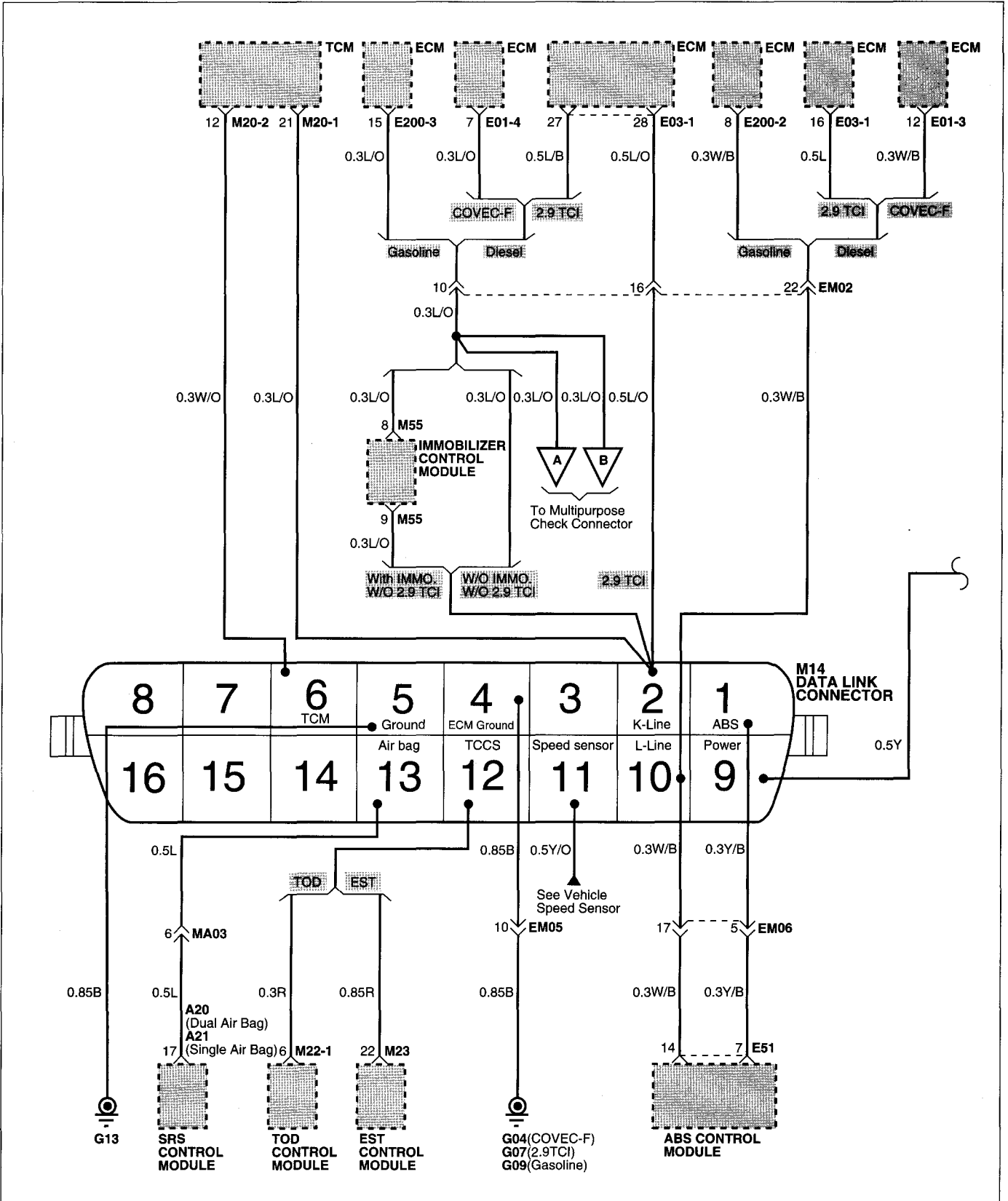

DATA LINK DETAILS (2)

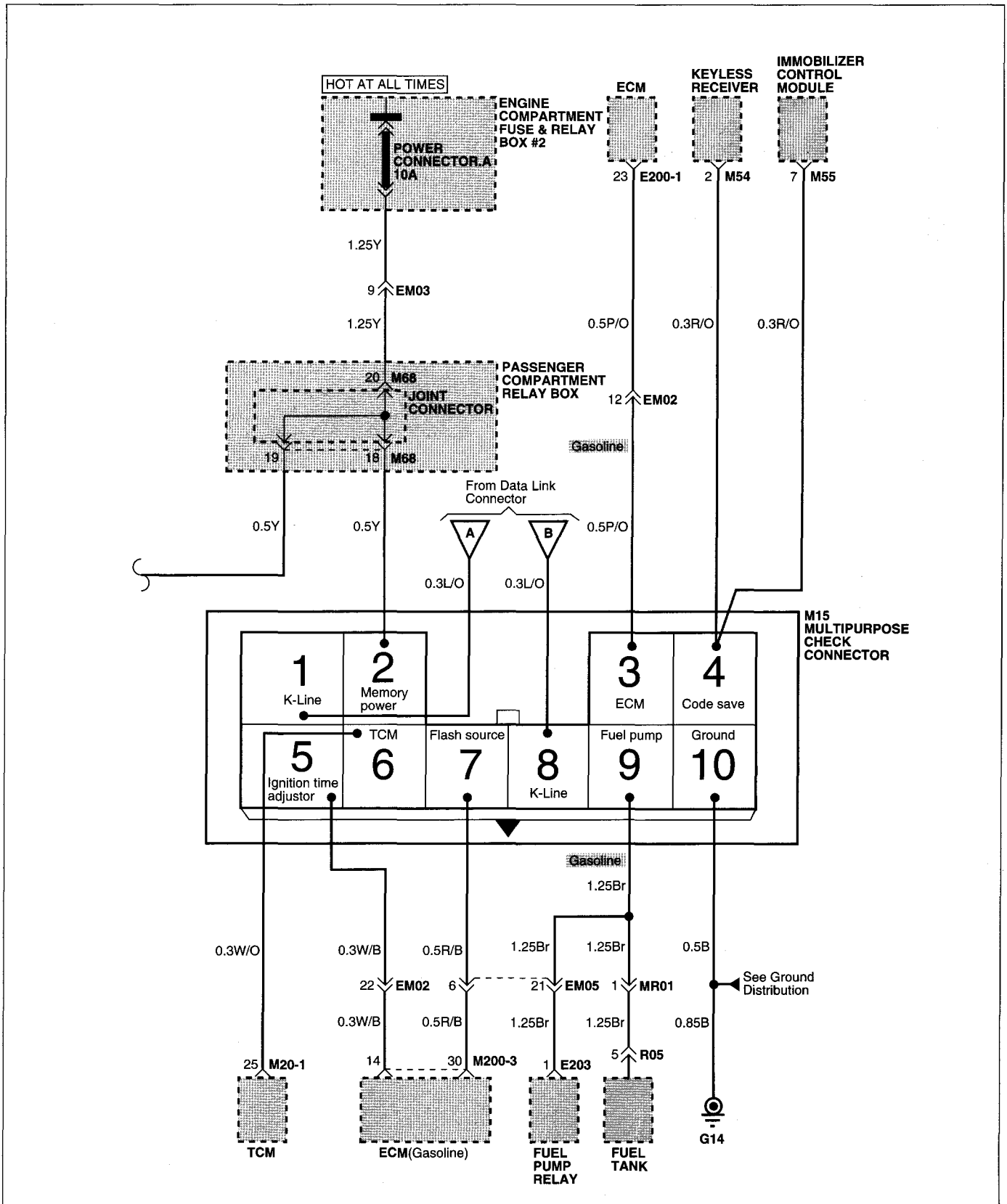

COMPONENT LOCATION INDEX

Components		Location reference - page
A20	SRS control module (Dual air dag)	CL-28
A21	SRS control module (Single air dag)	CL-28
E01-1	ECM (COVEC-F)	CL- 8
E01-3	ECM (COVEC-F)	CL- 8
E01-4	ECM (COVEC-F)	CL- 8
E03-1	ECM (2.9TCI)	CL- 8
E51	ABS control module	CL-11
E200-1	ECM (Gasoline)	CL-16
E200-2	ECM (Gasoline)	CL-16
E200-3	ECM (Gasoline)	CL-16
E203	Fuel pump relay	CL-16
M14	Data link connector	CL- 2
M15	Multipurpose check connector	CL- 2
M20-1	TCM	CL- 3
M20-2	TCM	CL- 3
M22-1	TOD control module	CL- 3
M23	EST control module	CL- 3
M54	Keyless receiver	CL- 5
M55	Immobilizer control module	CL- 5
M68	Joint connector	CL- 5
R05	Fuel tank (Gasoline)	CL-24
Connectors		
EM02		CL-19
EM03		CL-19
EM05		CL-19
EM06		CL-19
MA03		CL- 6
MR01		CL- 7
Grounds		
G04		CL-29
G07		CL-29
G09		CL-29
G13		CL-29
G14		CL-29

VEHICLE SPEED SENSOR

E25FB640

VEHICLE SPEED SENSOR (1)

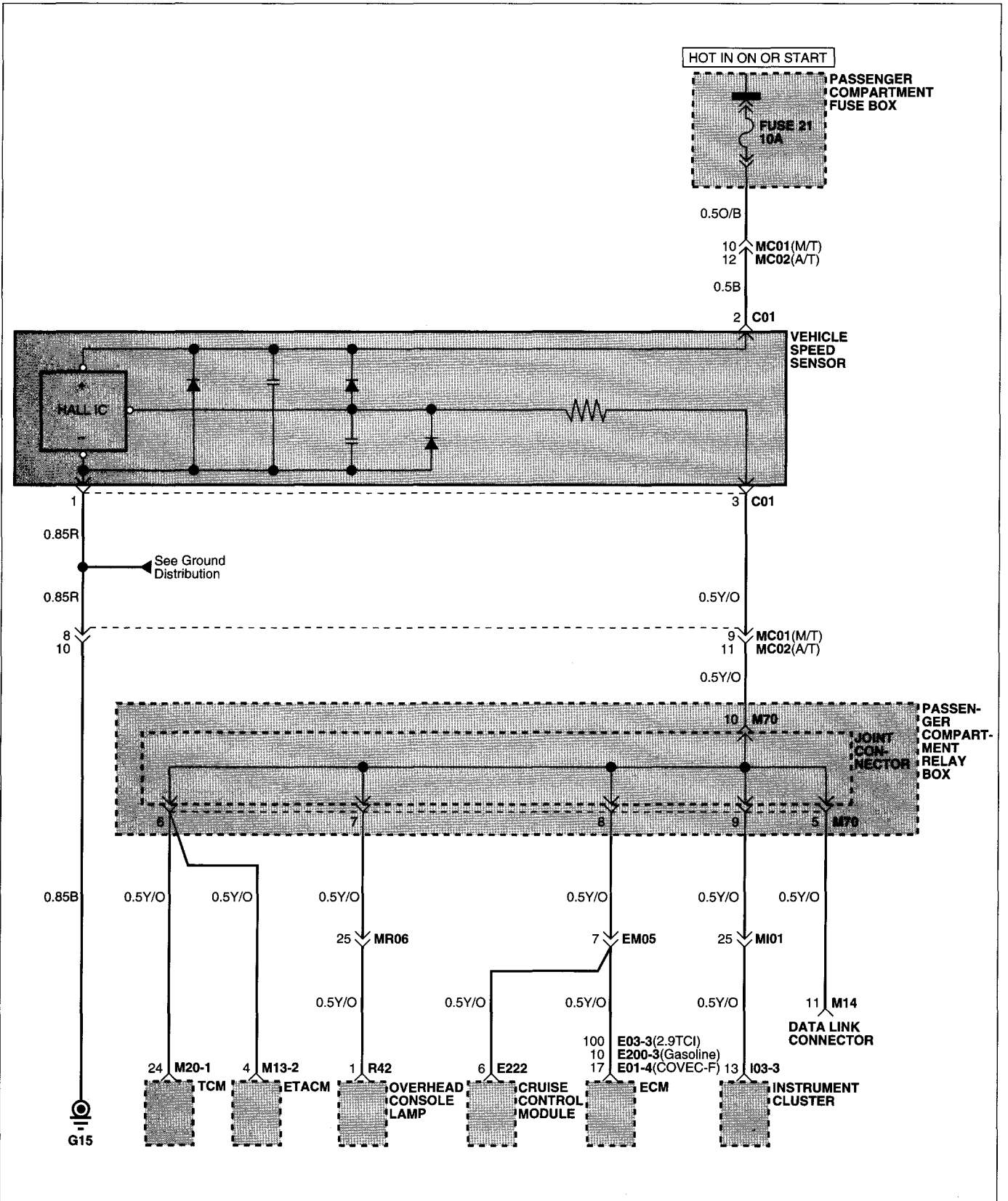

COMPONENT LOCATION INDEX

Components		Location reference - page
C01	Vehicle speed sensor	CL-21
E01-4	ECM (COVEC-F)	CL- 8
E03-3	ECM (2.9TCI)	CL- 8
E200-3	ECM (Gasoline)	CL-16
E222	Cruise control module	CL-17
I03-3	Instrument cluster	CL-20
M13-2	ETACM	CL-20
M14	Data link connector	CL- 2
M20-1	TCM	CL- 3
M22-1	TOD control module	CL- 3
M23	EST control module	CL- 3
M70	Overhead console lamp	CL- 5
R42	Joint connector	CL-26
Connectors		
EM05		CL-19
MC01		CL- 6
MC02		CL- 6
MI01		CL- 6
MR06		CL- 7
Grounds		
G15		CL-30

Circuit Description

The vehicle speed sensor installed on the speedometer driven gear generates pulse signals, which indicate the vehicle speed, and provides the signals to the control modules (ECM, TCM, ETACM, Cruise control module)

The control modules calculate the vehicle speed and send signals to control appropriate actuator.

The vehicle speed sensor (VSS) intermittently grounds the circuits and the number of pulses per minute increases/decreases with the speed of the vehicle.

STARTING SYSTEM

EFE895CA

STARTING SYSTEM (1)

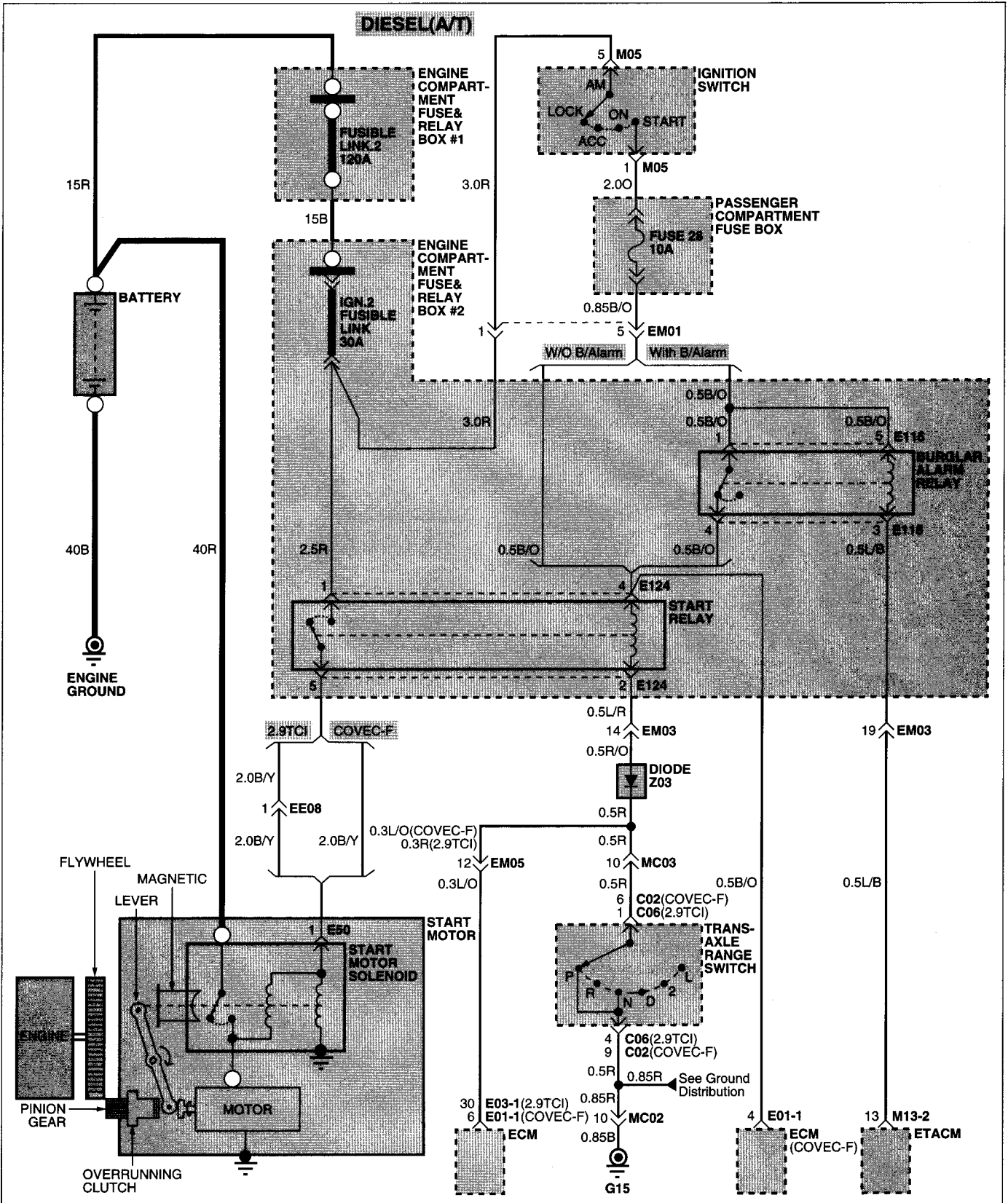

STARTING SYSTEM (2)

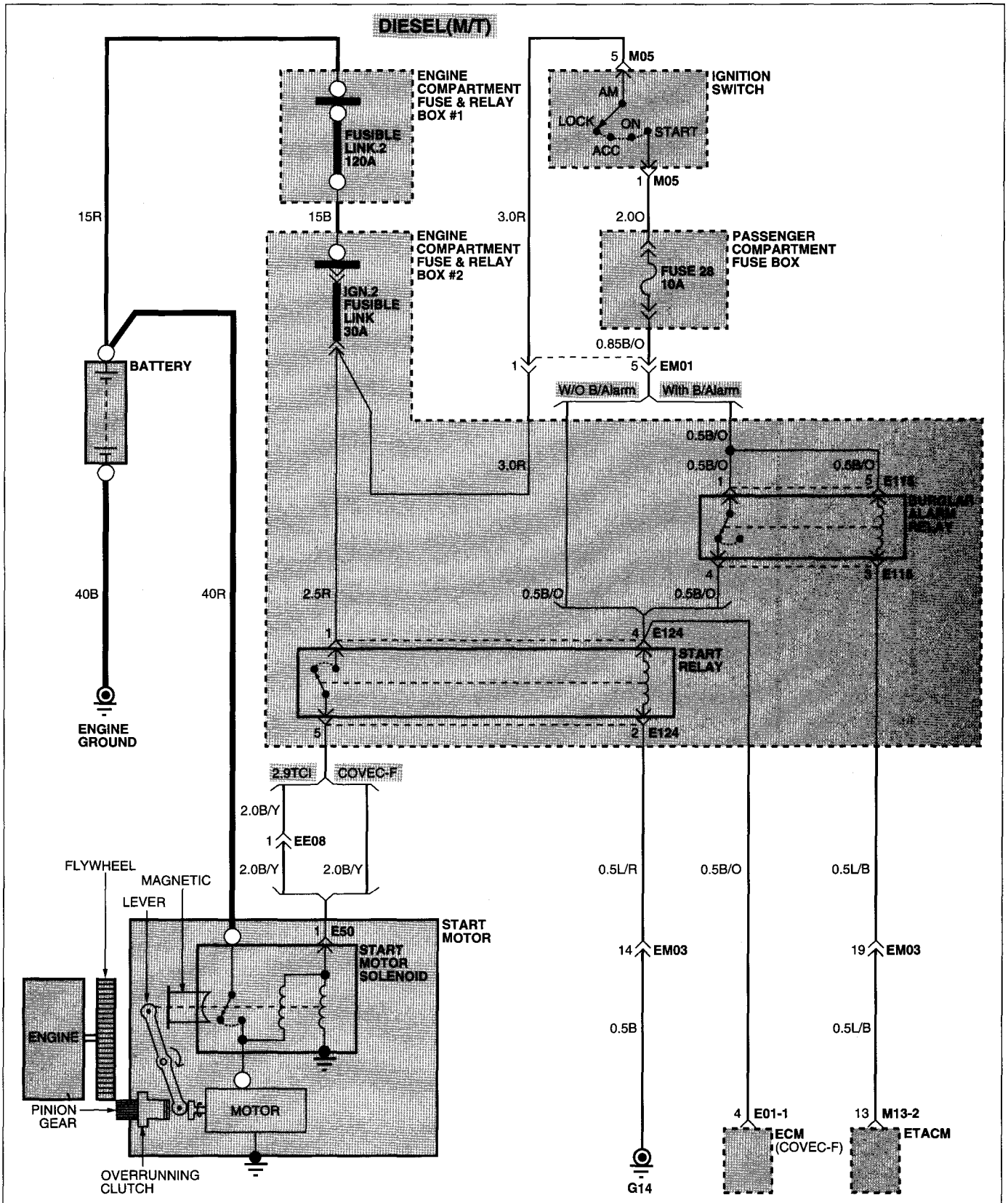

STARTING SYSTEM (3)

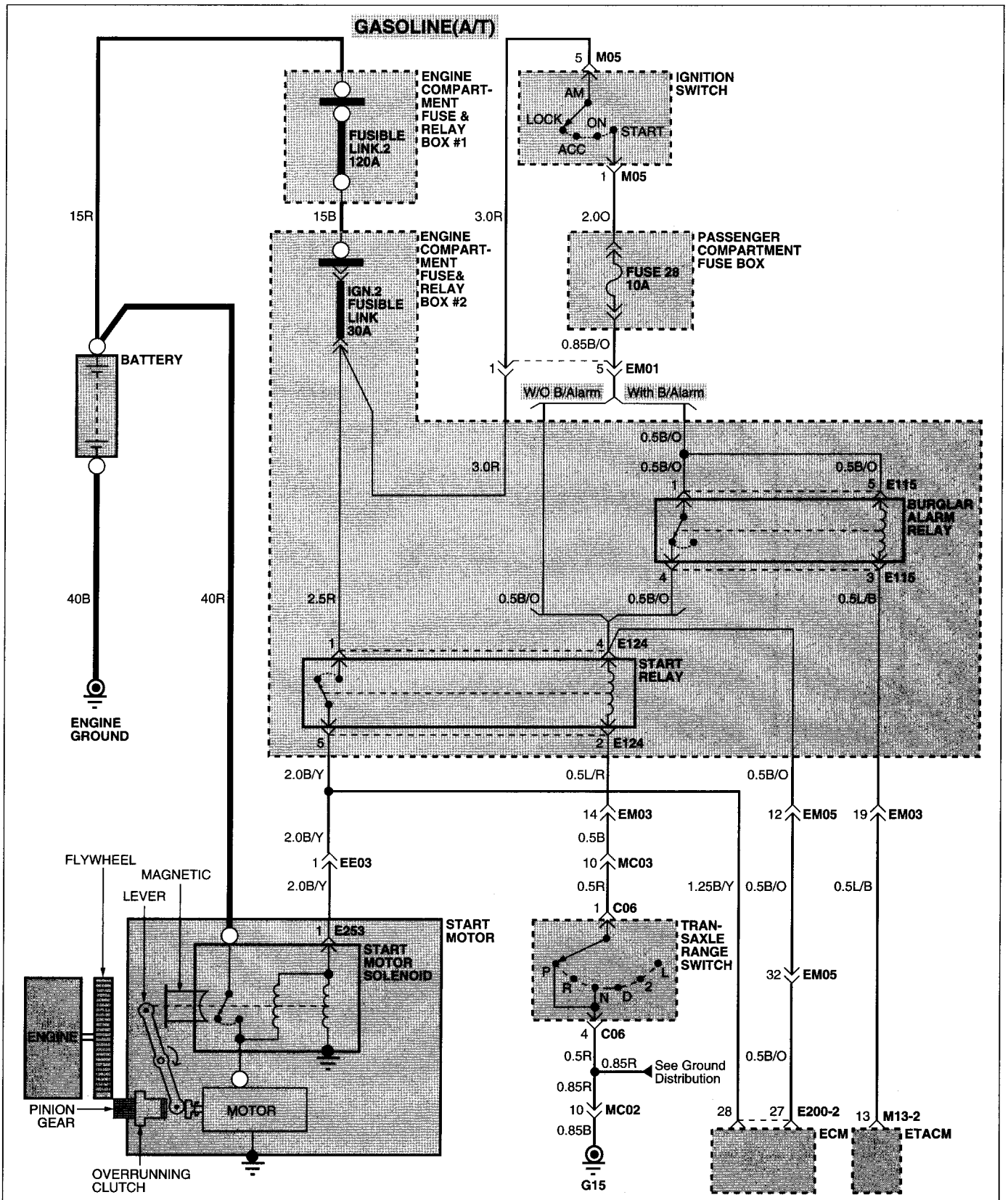

STARTING SYSTEM (4)

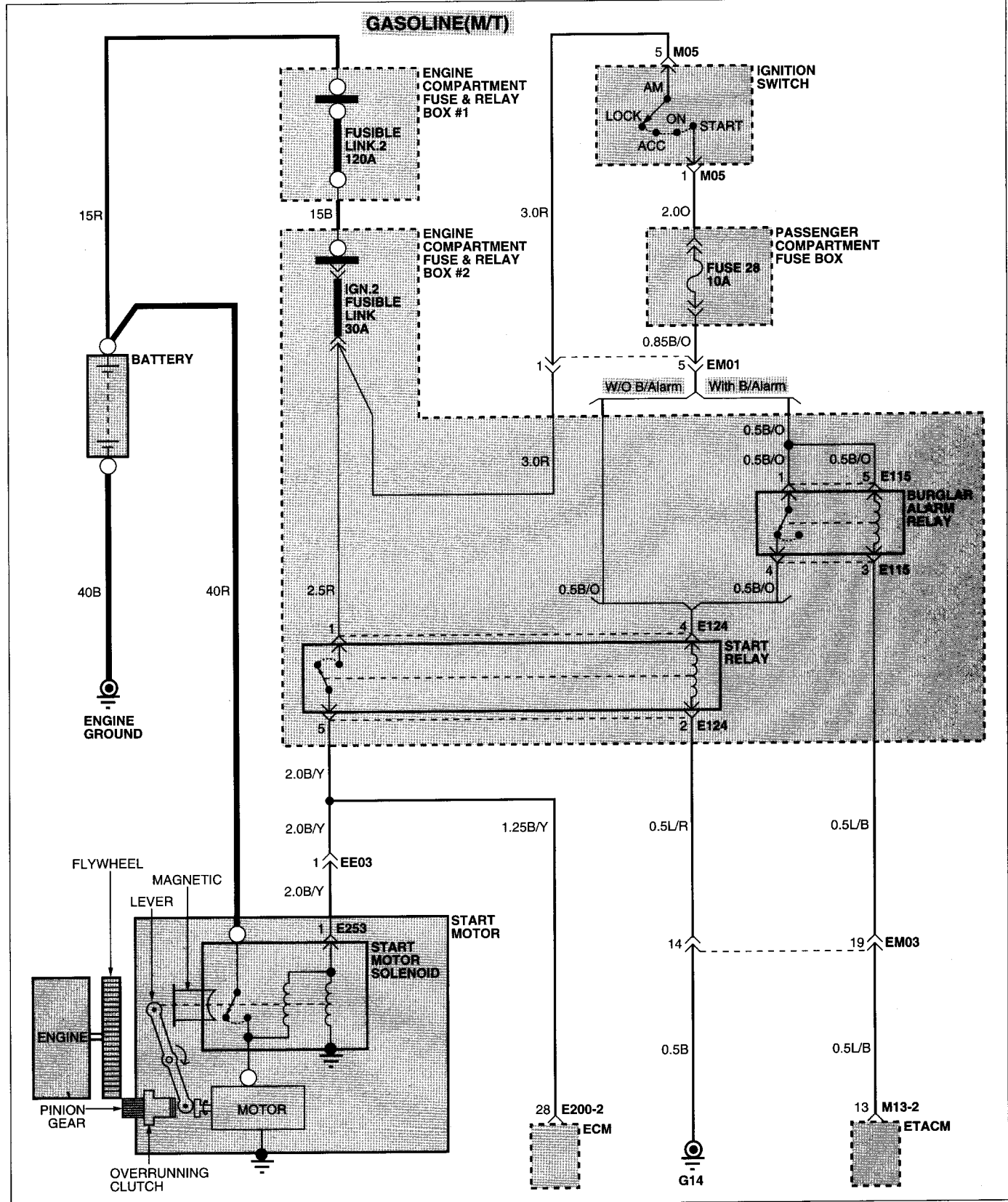

COMPONENT LOCATION INDEX

Components		Location reference - page
C02	Transaxle range switch (COVEC-F)	CL-21
C06	Transaxle range switch (Gasoline/2.9TCI)	CL-21
E01-1	ECM (COVEC-F)	CL- 8
E03-1	ECM (2.9TCI)	CL- 8
E50	Start motor solenoid (Diesel)	CL-11
E115	Burglar alarm relay	CL-14
E124	Start relay	CL-14
E200-2	ECM (Gasoline)	CL-16
E253	Start motor solenoid (Gasoline)	CL-18
M05	Ignition switch	CL- 2
M13-2	ETACM	CL- 2
Connectors		
EE03		CL-18
EE08		CL-19
EM01		CL-19
EM03		CL-19
EM05		CL-19
MC02		CL- 6
MC03		CL- 6
Grounds		
G14		CL-29
G15		CL-30

Circuit Description

Battery voltage is applied at all times from the positive battery terminal to the ignition switch and the normally open starter relay contacts. When the ignition switch is turned to START and the transaxle range switch (automatic transaxle) is in the P/N position, or the clutch pedal position switch (manual transaxle) is closed, battery voltage is applied through the fusible link to the starter relay coils, and then the coil is energized.

Battery voltage is applied to the starter solenoid through the starter relay closed contacts, and the start motor engages to start the engine. The ETACS control module controls the starting system through the burglar alarm relay coil (with burglar alarm).

CHARGING SYSTEM EEAE9FB9

CHARGING SYSTEM (1)

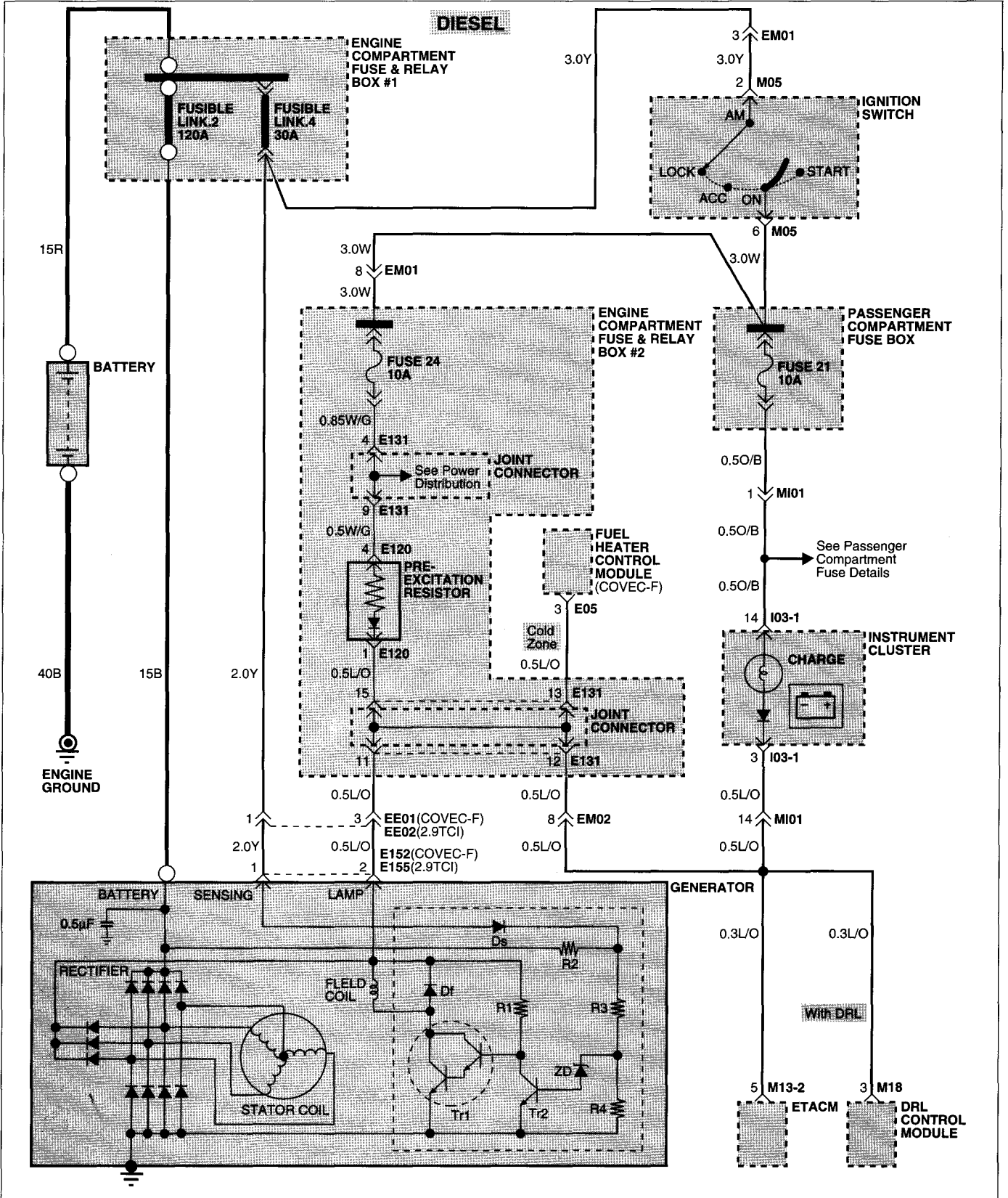

CHARGING SYSTEM (2)

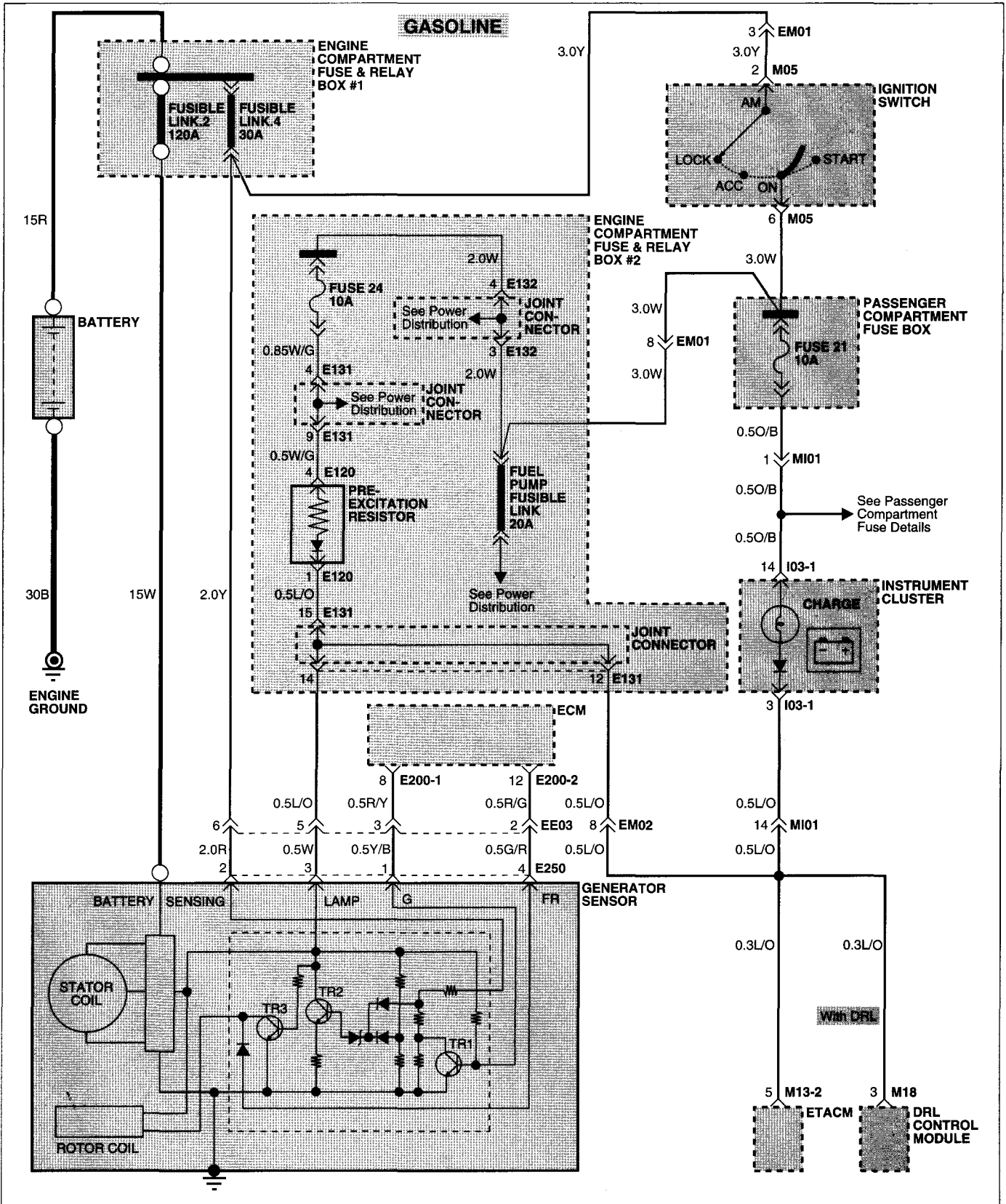

COMPONENT LOCATION INDEX

Components		Location reference - page
E05	Fuel heater control module	CL- 8
E120	Pre-excitation resistor	CL-14
E131	Joint connector	CL-14
E132	Joint connector	CL-14
E152	Generator (COVEC-F)	CL-15
E155	Generator (2.9TCl)	CL-15
E200-1	ECM (Gasoline)	CL-16
E200-2	ECM (Gasoline)	CL-16
E250	Generator sensor (Gasoline)	CL-18
I03-1	Instrument cluster	CL-20
M05	Ignition switch	CL- 2
M13-2	ETACM	CL- 2
M18	DRL control module	CL- 3
Connectors		
EE01		CL-18
EE02		CL-18
EE03		CL-18
EM01		CL-19
EM02		CL-19
MI01		CL- 6

Circuit Description

The generator produces AC voltage in its windings as it is belt-driven by the engine. The rectifier converts this AC voltage to DC voltage.

The voltage regulator, a device built-in to the generator frame, has the primary function of controlling the generator's output to meet electrical system requirements. The regulator also controls the charge warning lamp. Fuse 21 supplies battery voltage to the charge warning indicator.

With the engine not running and the ignition switch ON, terminal L of the regulator is grounded internally and the indicator lights up. A small amount of current provided by both the charge warning lamp and the pre-excitation resistor is used to "excite" the magnetic field windings to start the charging process. With the engine running and the generator charging, terminal L voltage rises and the indicator lamp goes out. If the generator fails to charge, terminal L remains below battery voltage and the indicator lamp remains lit.

COOLING SYSTEM

EDD3D3BB

COOLING SYSTEM (1)

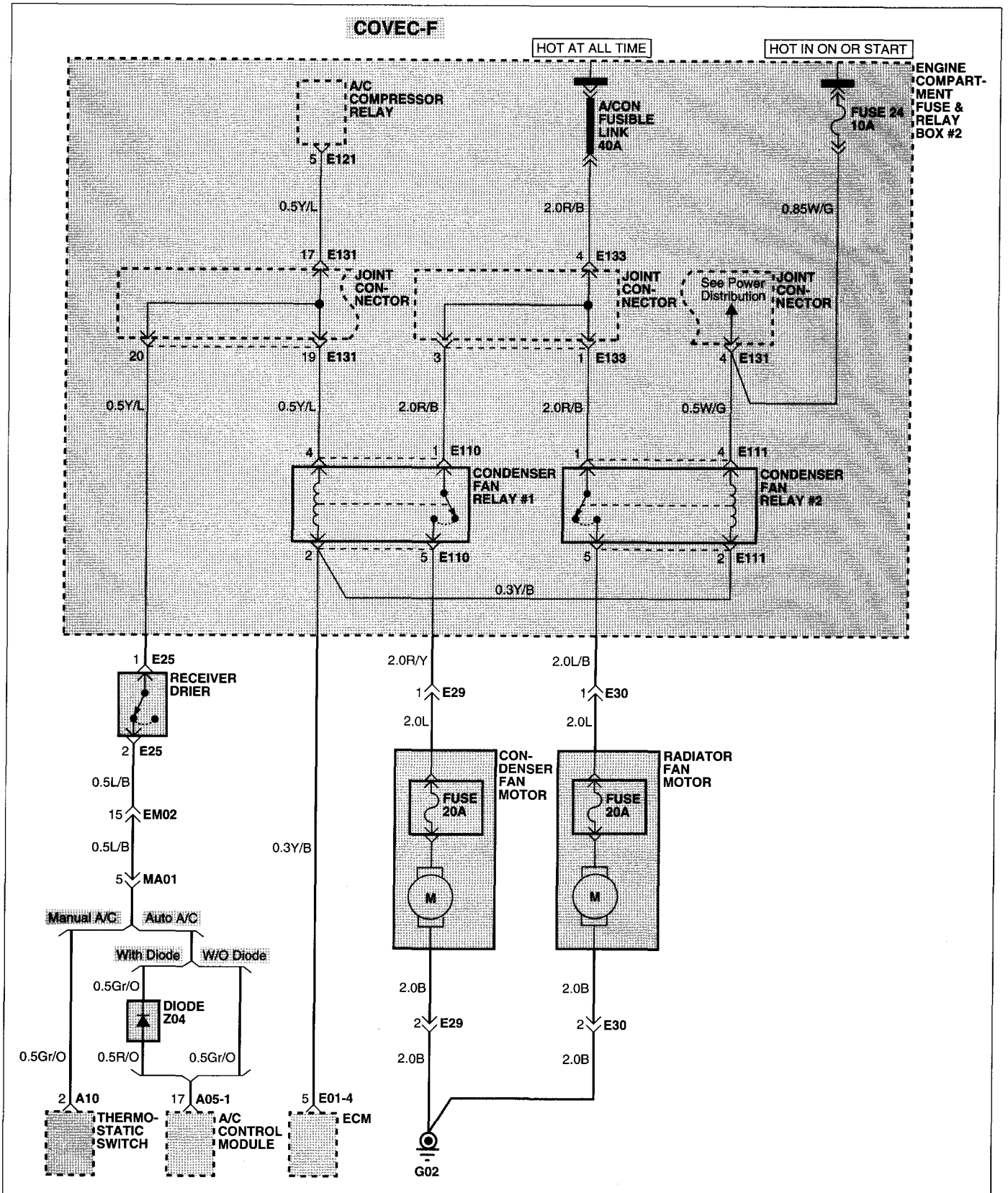

COOLING SYSTEM (2)

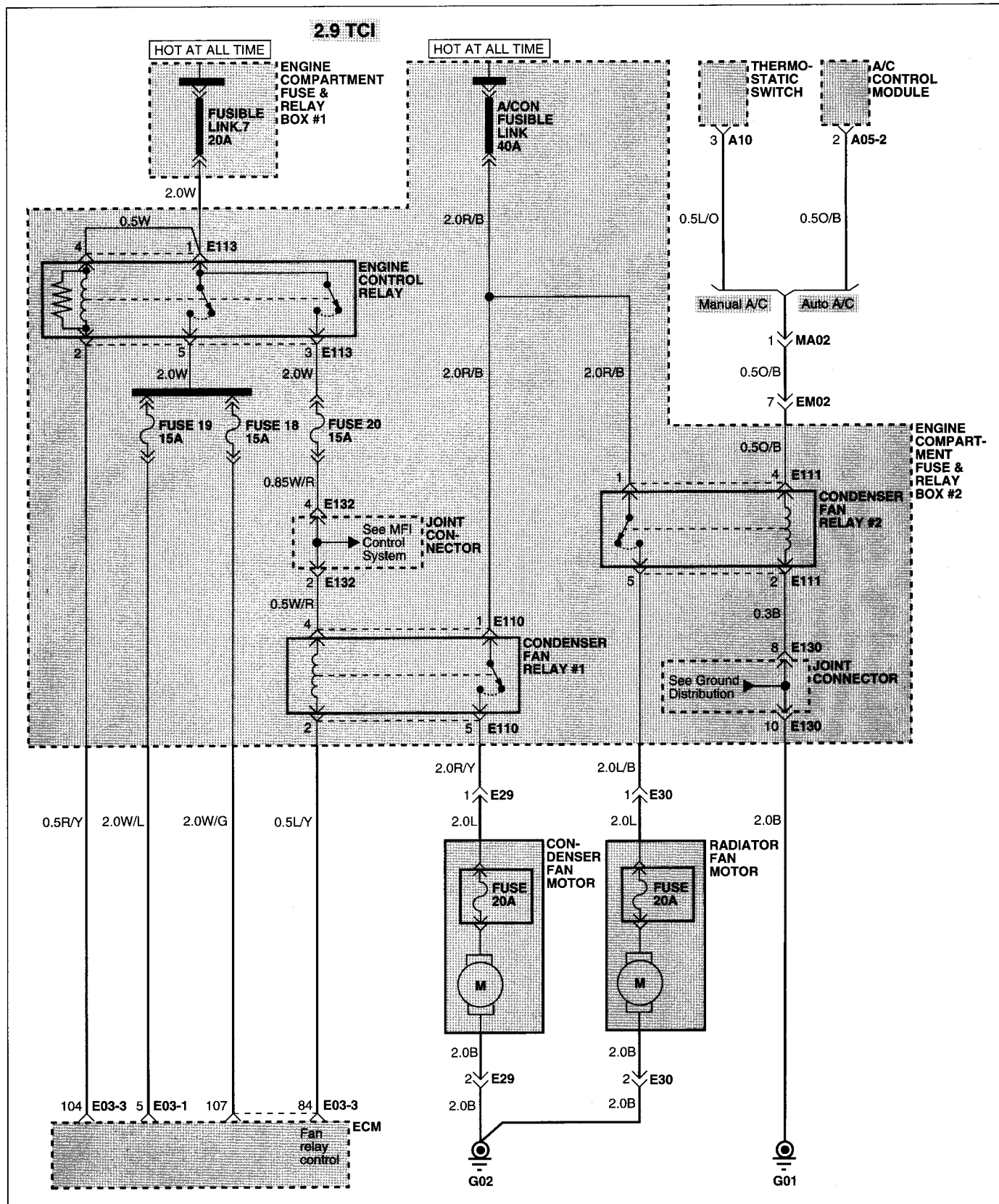

COOLING SYSTEM (3)

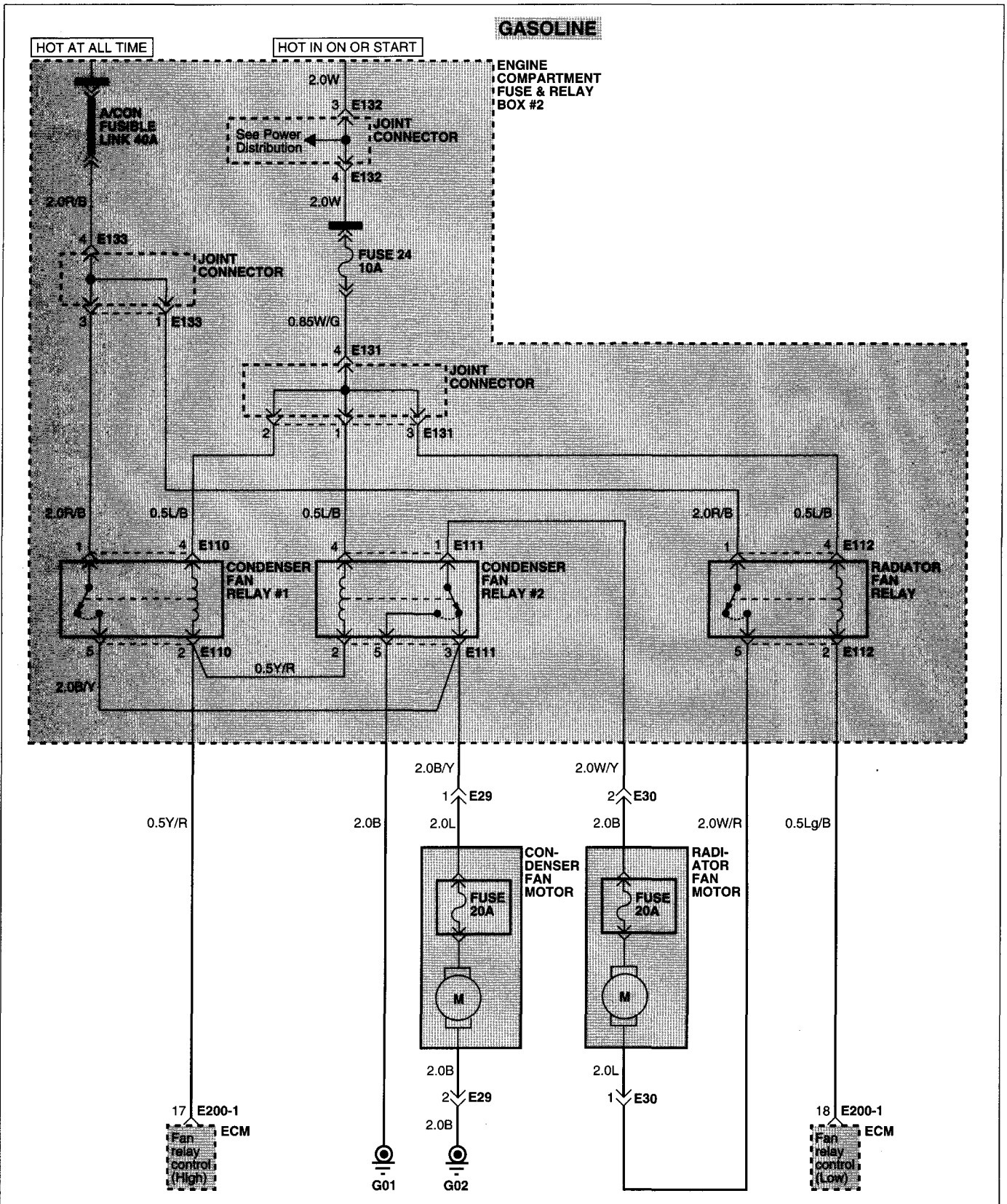

COMPONENT LOCATION INDEX

Components		Location reference - page
A05-1	A/C control module	CL-27
A05-2	A/C control module	CL-27
A10	Thermostatic	CL-27
E01-4	ECM (COVEC-F)	CL- 8
E03-1	ECM (2.9TCl)	CL- 8
E03-3	ECM (2.9TCl)	CL- 8
E25	Receiver drier	CL- 9
E29	Condenser fan motor	CL- 9
E30	Radiator fan motor	CL- 9
E110	Condenser fan relay.1	CL-14
E111	Condenser fan relay.2	CL-14
E112	Radiator fan relay	CL-14
E113	Engine control relay	CL-14
E121	A/C compressor relay	CL-14
E130	Joint connector	CL-14
E131	Joint connector	CL-14
E132	Joint connector	CL-14
E133	Joint connector	CL-14
E200-1	ECM (Gasoline)	CL-16
Connectors		
EM01		CL-19
EM02		CL-19
MA01		CL- 6
MA02		CL- 6
Grounds		
G01		CL-29
G02		CL-29

Circuit Description

The ECM (Engine Control Module) controls the operation of the radiator fan motor and the condenser fan motor through a relay. The control module monitors coolant temperature through the engine coolant temperature sensor.

The module also monitors A/C operation through the A/C switch ON input and A/C pressure switch input. Using these input signals, the module controls the coil of the appropriate relays (condenser fan relays and radiator fan relay) to provide optimal cooling fan operation.

MFI CONTROL SYSTEM (COVEC-F) EDE9A583

MFI CONTROL SYSTEM (COVEC-F) (1)

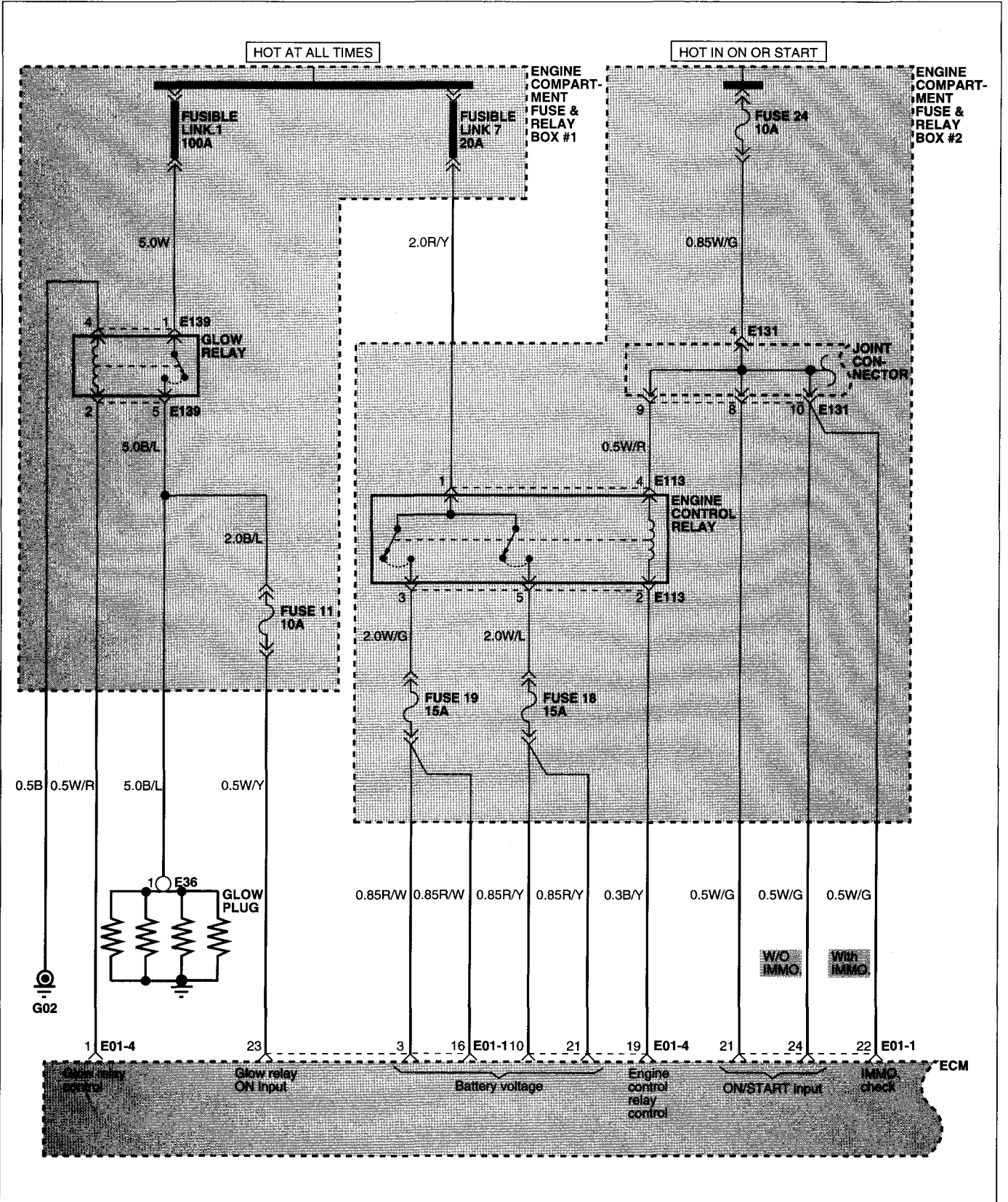

MFI CONTROL SYSTEM (COVEC-F) (2)

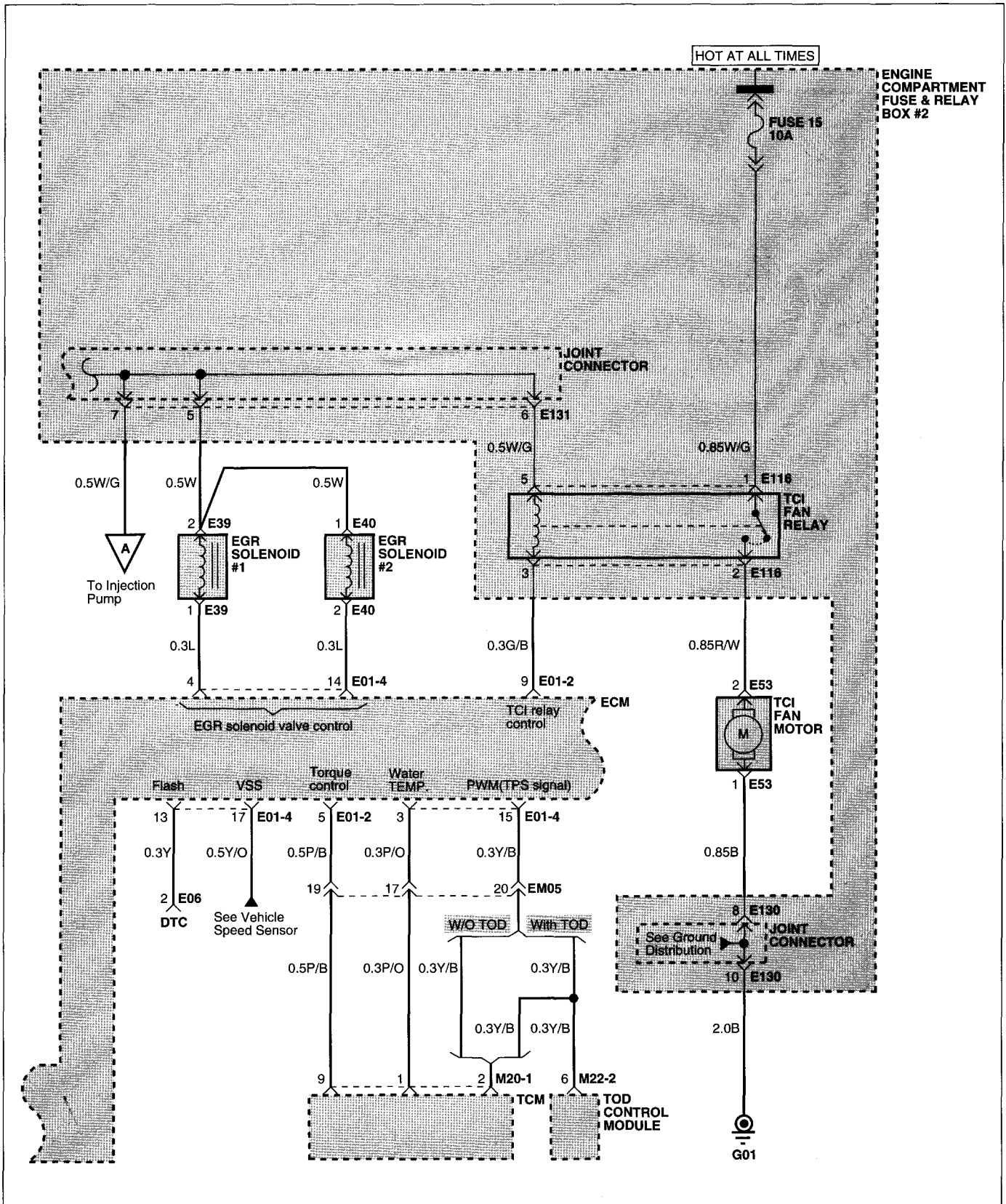

MFI CONTROL SYSTEM (COVEC-F) (3)

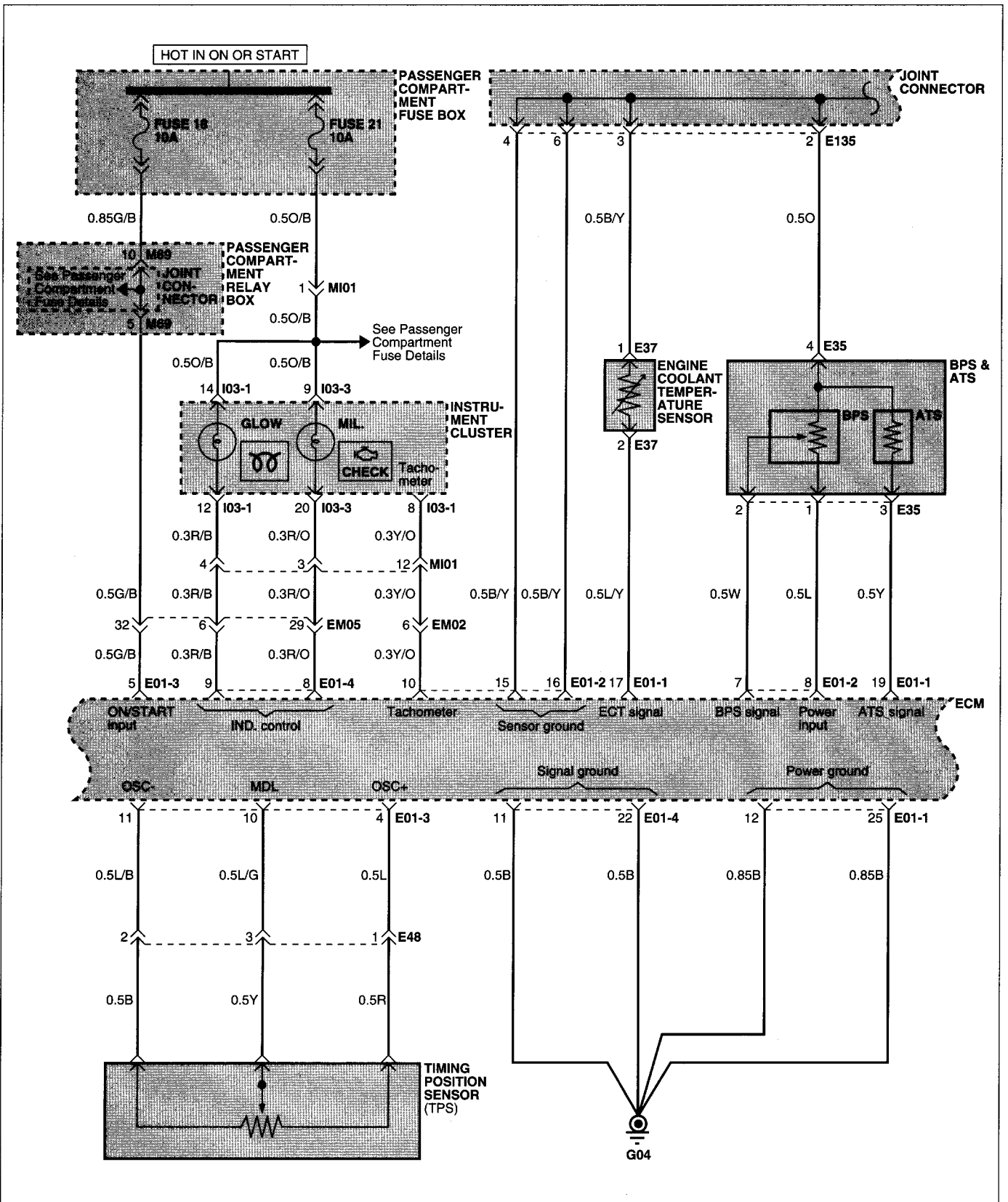

MFI CONTROL SYSTEM (COVEC-F) (4)

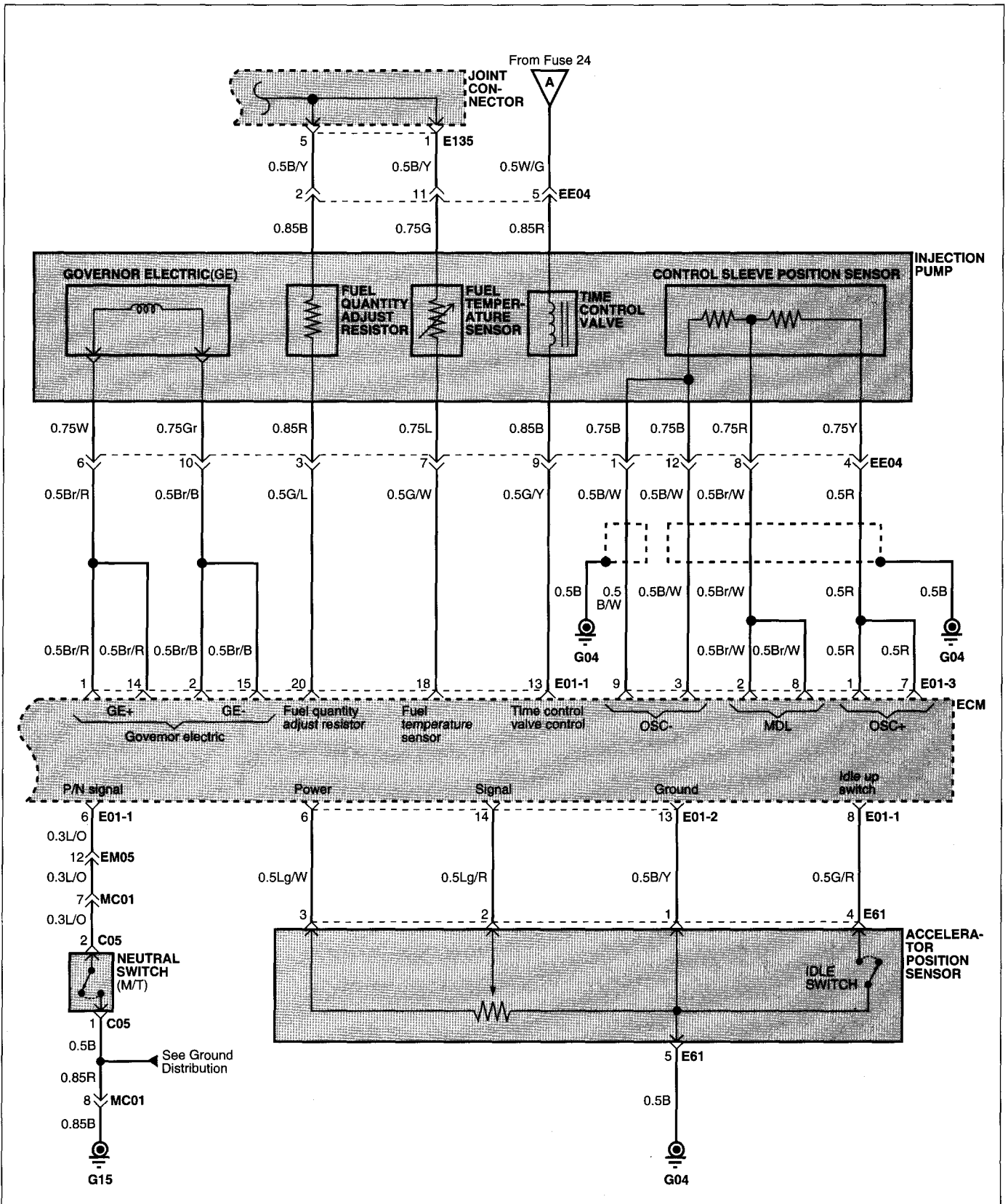

MFI CONTROL SYSTEM (COVEC-F) (5)

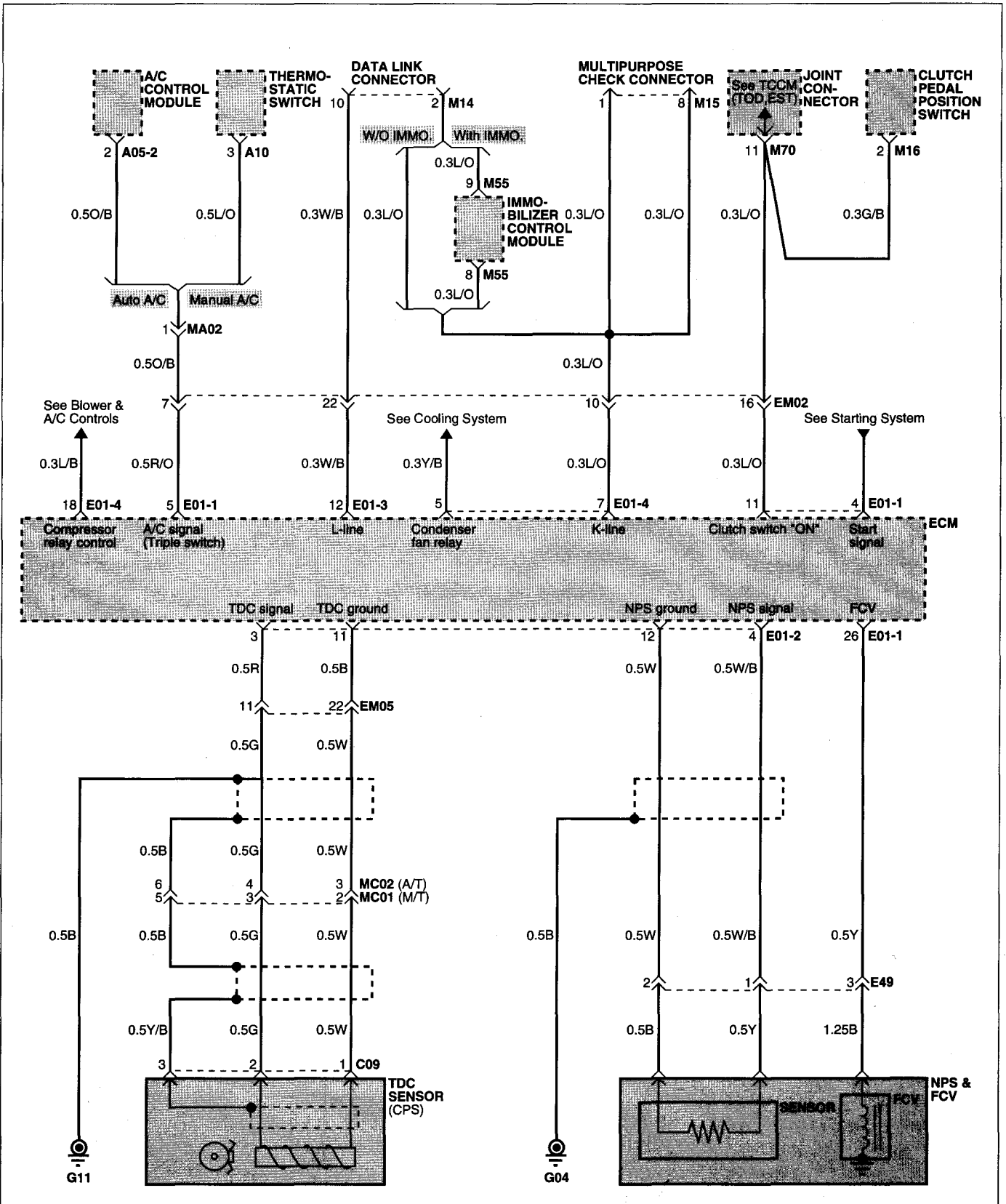

COMPONENT LOCATION INDEX

Components		Location reference - page
A05-2	A/C control module (Auto A/C)	CL-27
A10	Thermostatic switch	CL-27
C05	Neutral switch (M/T)	CL-21
C09	TDC sensor	CL-21
E01-1	ECM	CL- 8
E01-2	ECM	CL- 8
E01-3	ECM	CL- 8
E01-4	ECM	CL- 8
E06	DTC	CL- 8
E35	BPS & ATS	CL-10
E36	Glow plug	CL-10
E37	Engine coolant temperature sensor	CL-10
E39	EGR solenoid #1	CL-10
E40	EGR solenoid #2	CL-10
E48	Timing position sensor	CL-10
E49	NPS	CL-10
E53	TCI fan motor	CL-11
E61	Accelerator position sensor	CL-12
E113	Engine control relay	CL-14
E116	TCI fan relay	CL-14
E130	Joint connector	CL-14
E131	Joint connector	CL-14
E135	Joint connector	CL-14
E139	Glow relay	CL-14
I03-1	Instrument cluster	CL-20
I03-3	Instrument cluster	CL-20
M14	Data link connector	CL- 2
M15	Multipurpose check connector	CL- 2
M16	Clutch pedal position switch	CL- 3
M20-1	TCM	CL- 3
M22-2	TOD control module	CL- 3
M55	Immobilizer control module	CL- 5
M69	Joint connector	CL- 5
M70	Joint connector	CL- 5

COMPONENT LOCATION INDEX

Connectors	Location reference - page
EE04	CL-18
EM02	CL-19
EM05	CL-19
MA02	CL- 6
MC01	CL- 6
MC02	CL- 6
MI01	CL- 6
Grounds	
G01	CL-29
G02	CL-29
G04	CL-29
G11	CL-29
G15	CL-30

Circuit Description

The Covec-F fuel injection system is a distributor type fuel injection system that uses a micro-computer to control fuel injection quantity and injection timing.

The Covec-F detects physical signals as electrical signals from each sensor and switch. The control unit (ECM) processes this information to electronically control injection timing and injection quantity.

MFI CONTROL SYSTEM (2.9TCI)

EF86AFD8

MFI CONTROL SYSTEM (2.9TCI) (1)

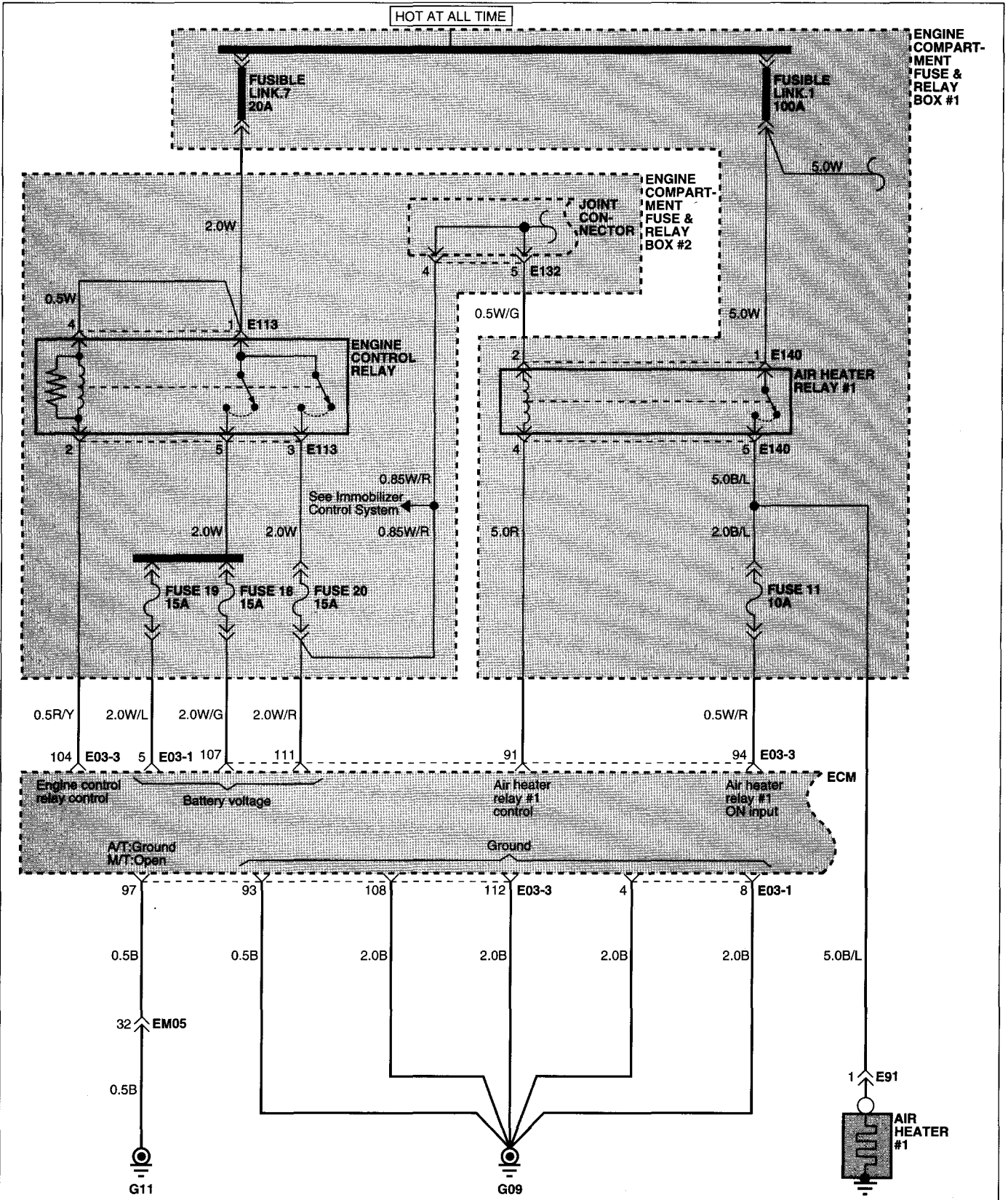

MFI CONTROL SYSTEM (2.9TCI) (2)

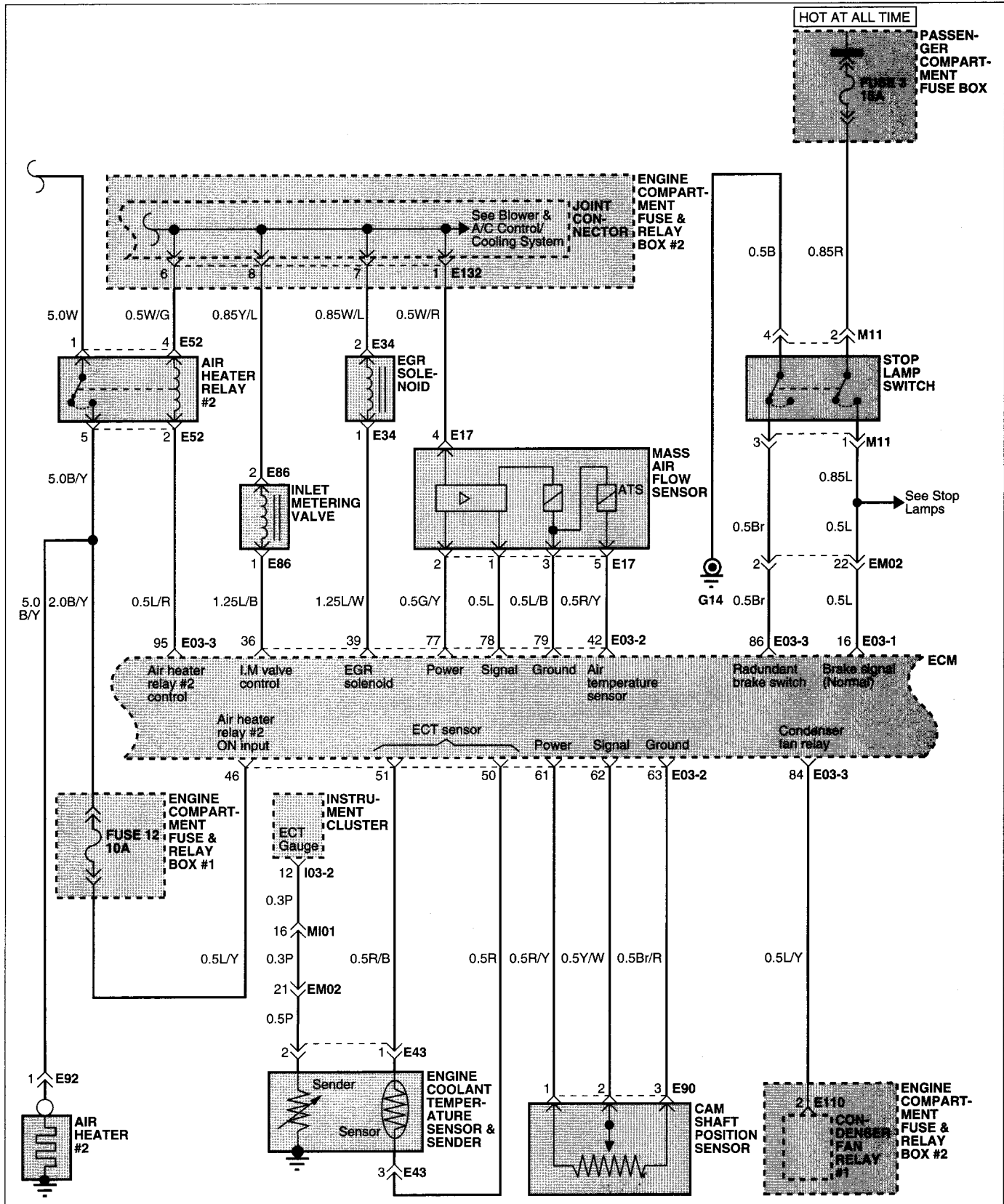

MFI CONTROL SYSTEM (2.9TCI) (3)

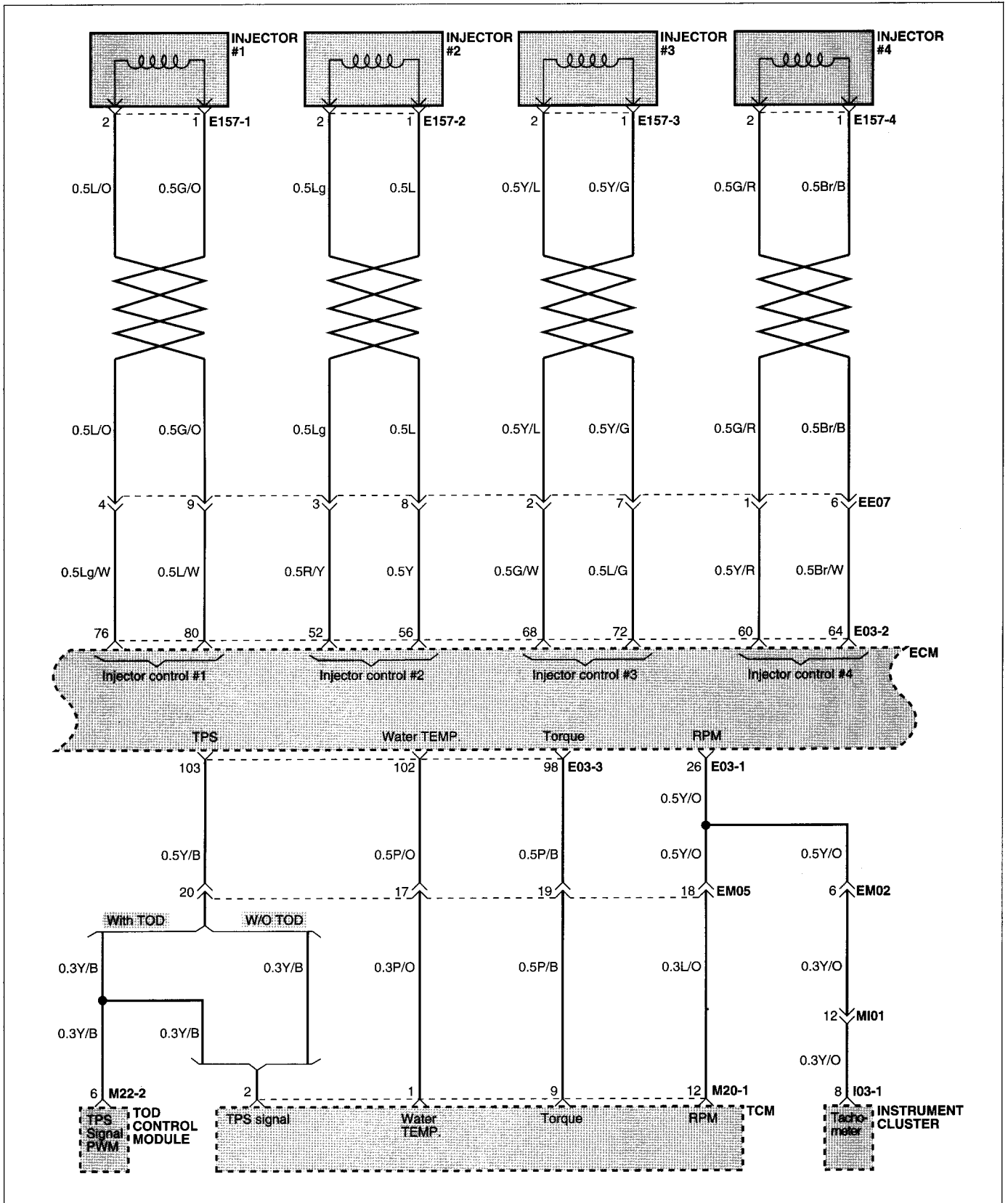

MFI CONTROL SYSTEM (2.9TCI) (4)

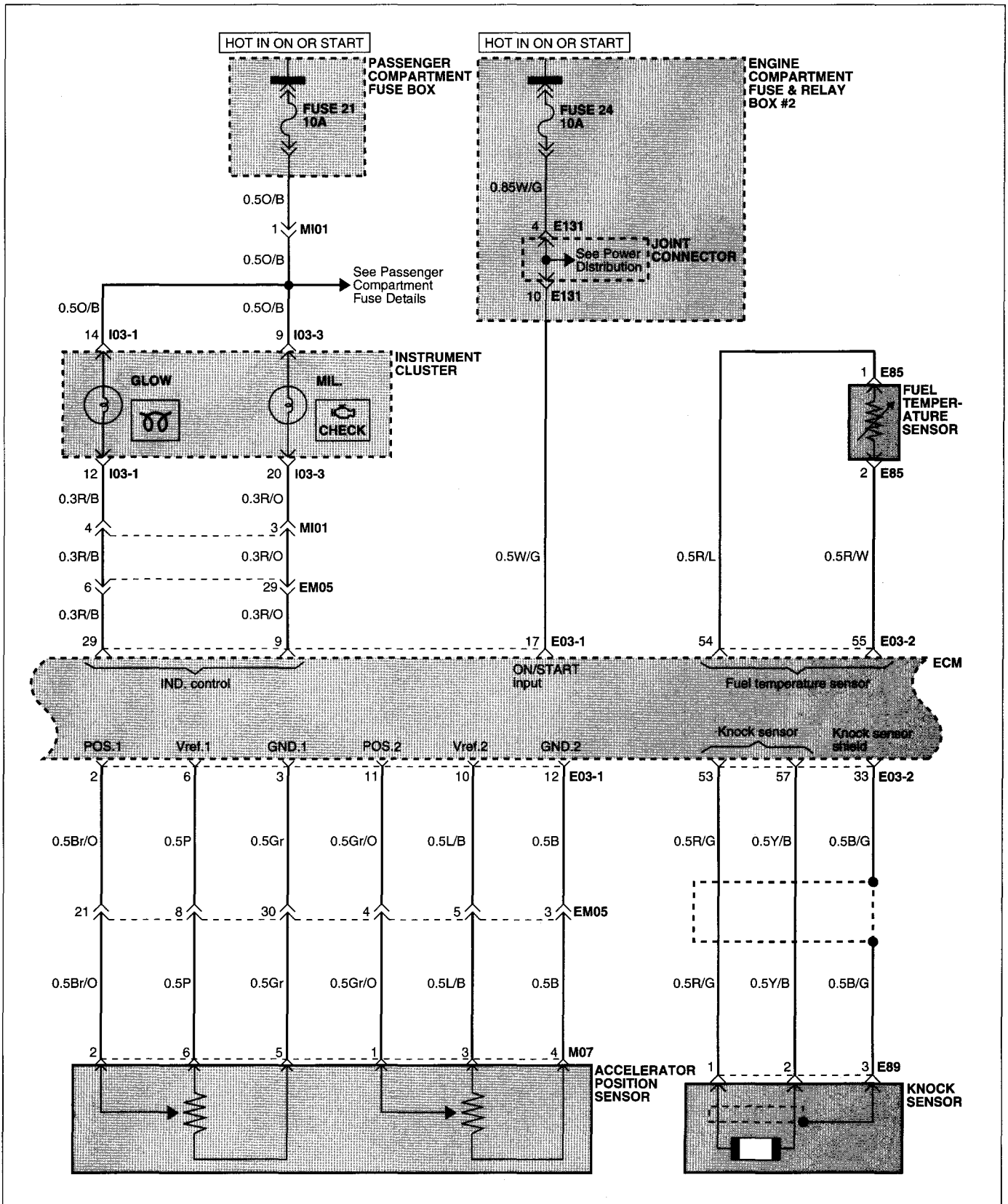

MFI CONTROL SYSTEM (2.9TCI) (5)

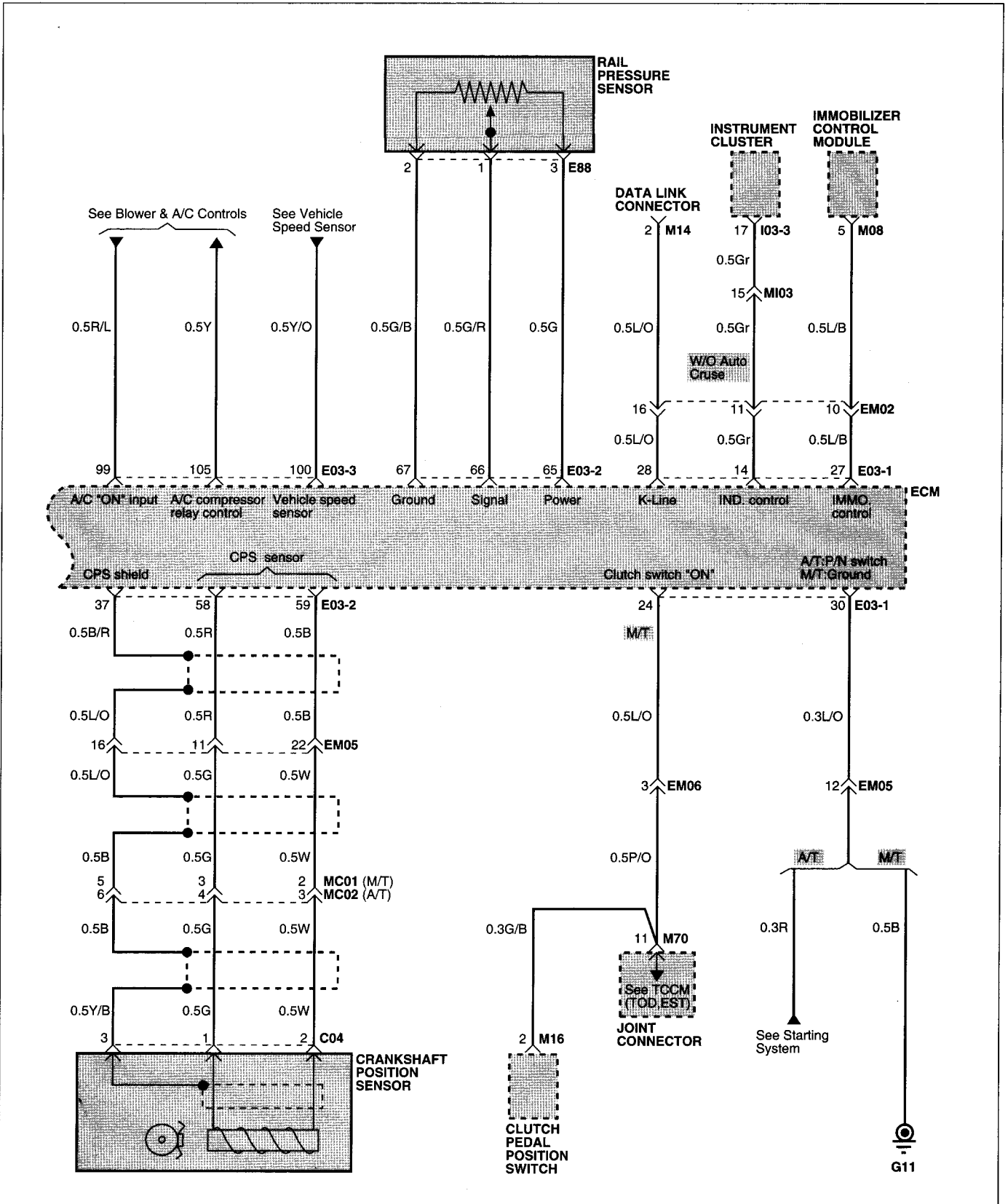

COMPONENT LOCATION INDEX

Component		Location reference - page
C04	Crankshaft position sensor	CL-21
E03-1	ECM	CL- 8
E03-2	ECM	CL- 8
E03-3	ECM	CL- 8
E17	Mass air flow sensor	CL- 8
E34	EGR solenoid	CL- 9
E43	Engine coolant temperature sensor & sender	CL-10
E52	Air heater relay #2	CL- 9
E85	Fuel temperature sensor	CL-13
E86	Inlet metering valve	CL-13
E88	Rail pressure sensor	CL-13
E89	Knock sensor	CL-13
E90	Camshaft position sensor	CL-13
E91	Air heater #1	CL-13
E92	Air heater #2	CL-13
E110	Condenser fan relay #1	CL-14
E113	Engine control relay	CL-14
E131	Joint connector	CL-14
E132	Joint connector	CL-14
E140	Air heater relay #1	CL-14
E157-1	Injector #1	CL-15
E157-2	Injector #2	CL-15
E157-3	Injector #3	CL-15
E157-4	Injector #4	CL-15
I03-1	Instrument cluster	CL-20
I03-2	Instrument cluster	CL-20
I03-3	Instrument cluster	CL-20
M07	Accelerator position sensor	CL- 2
M08	Immobilizer control module	CL- 2
M11	Stop lamp switch	CL- 3
M14	Data link connector	CL- 2
M16	Clutch pedal position switch	CL- 3
M20-1	TCM	CL- 3
M22-2	TOD control module	CL- 3
M70	Joint connector	CL- 5
Connectors		
EE07		CL-19
EM02		CL-19
EM05		CL-19
EM06		CL-19
MC01		CL- 6
MC02		CL- 6
MI01		CL- 6
Grounds		
G09		CL-29
G11		CL-29
G14		CL-29

MFI CONTROL SYSTEM (GASOLINE) EAC14F42

MFI CONTROL SYSTEM (GASOLINE) (1)

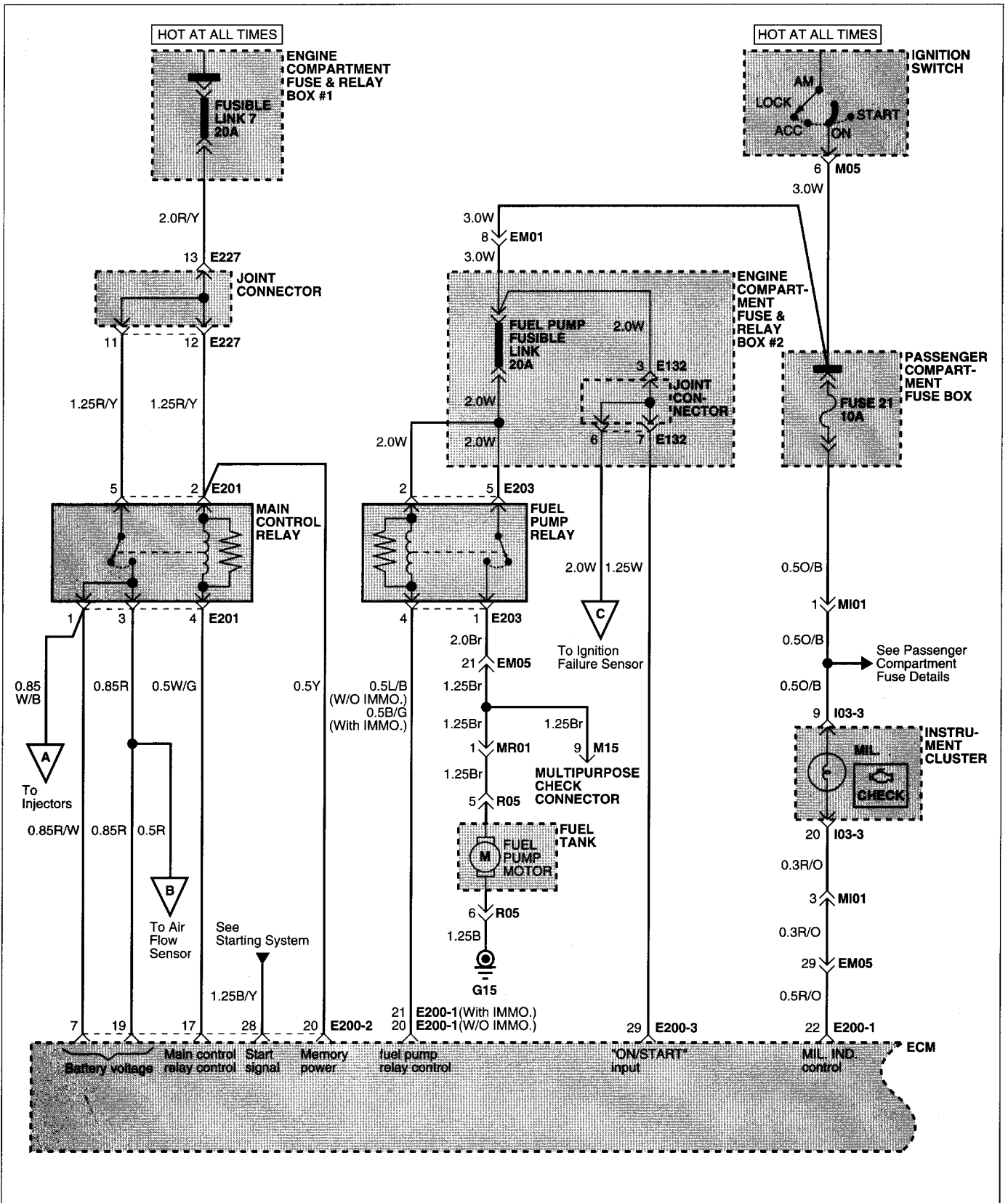

MFI CONTROL SYSTEM (GASOLINE) (2)

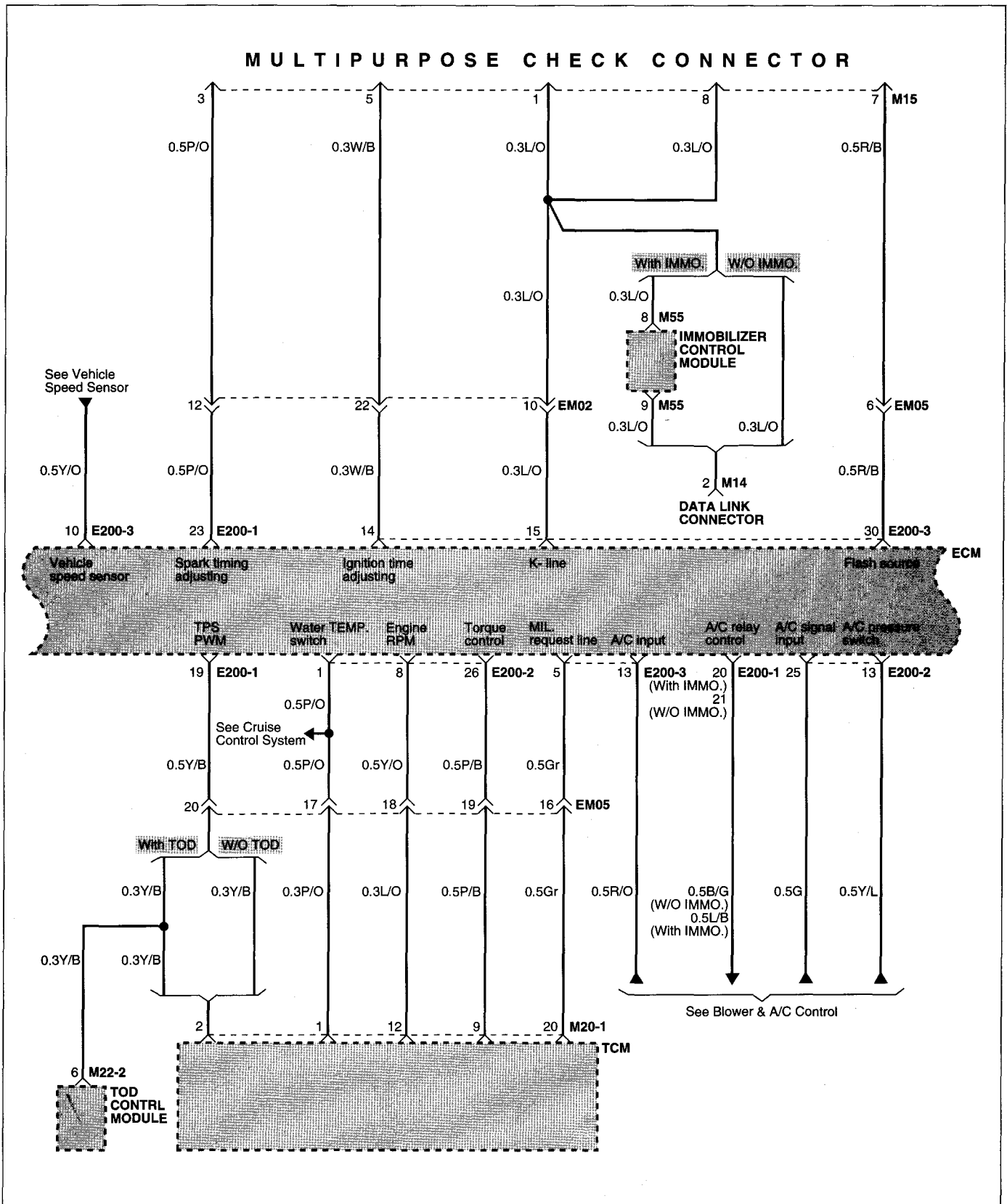

MFI CONTROL SYSTEM (GASOLINE) (3)

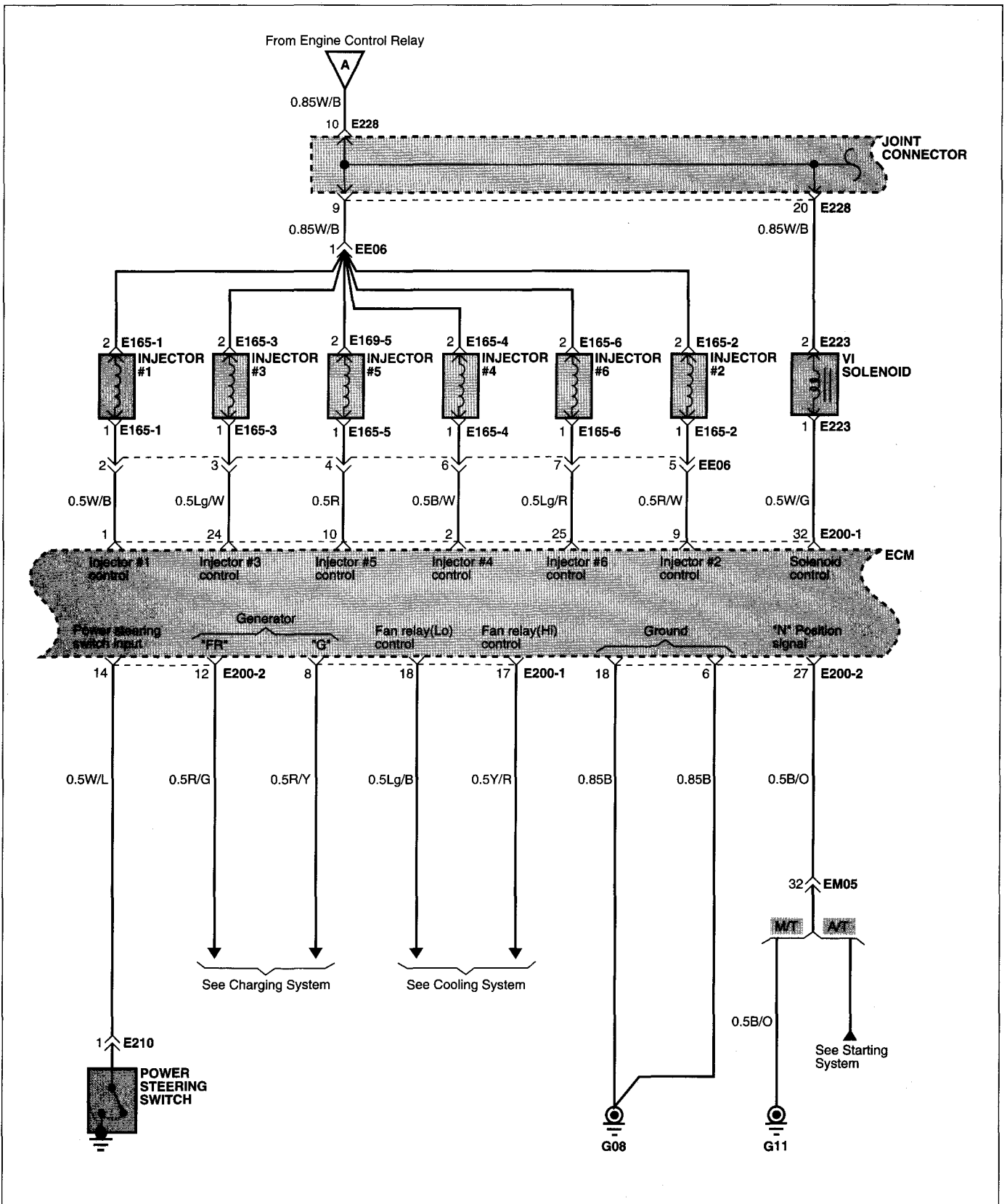

MFI CONTROL SYSTEM (GASOLINE) (4)

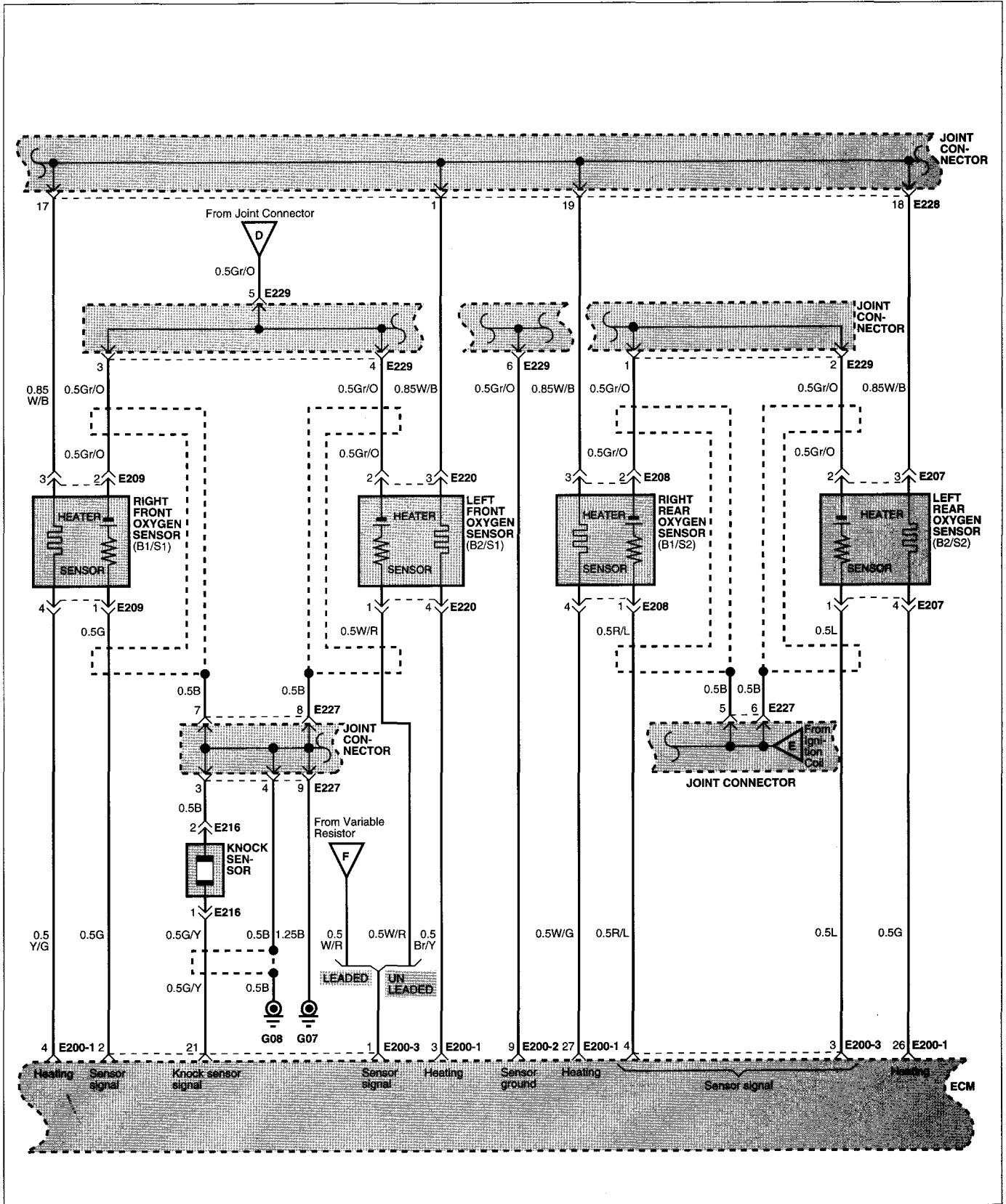

MFI CONTROL SYSTEM (GASOLINE) (5)

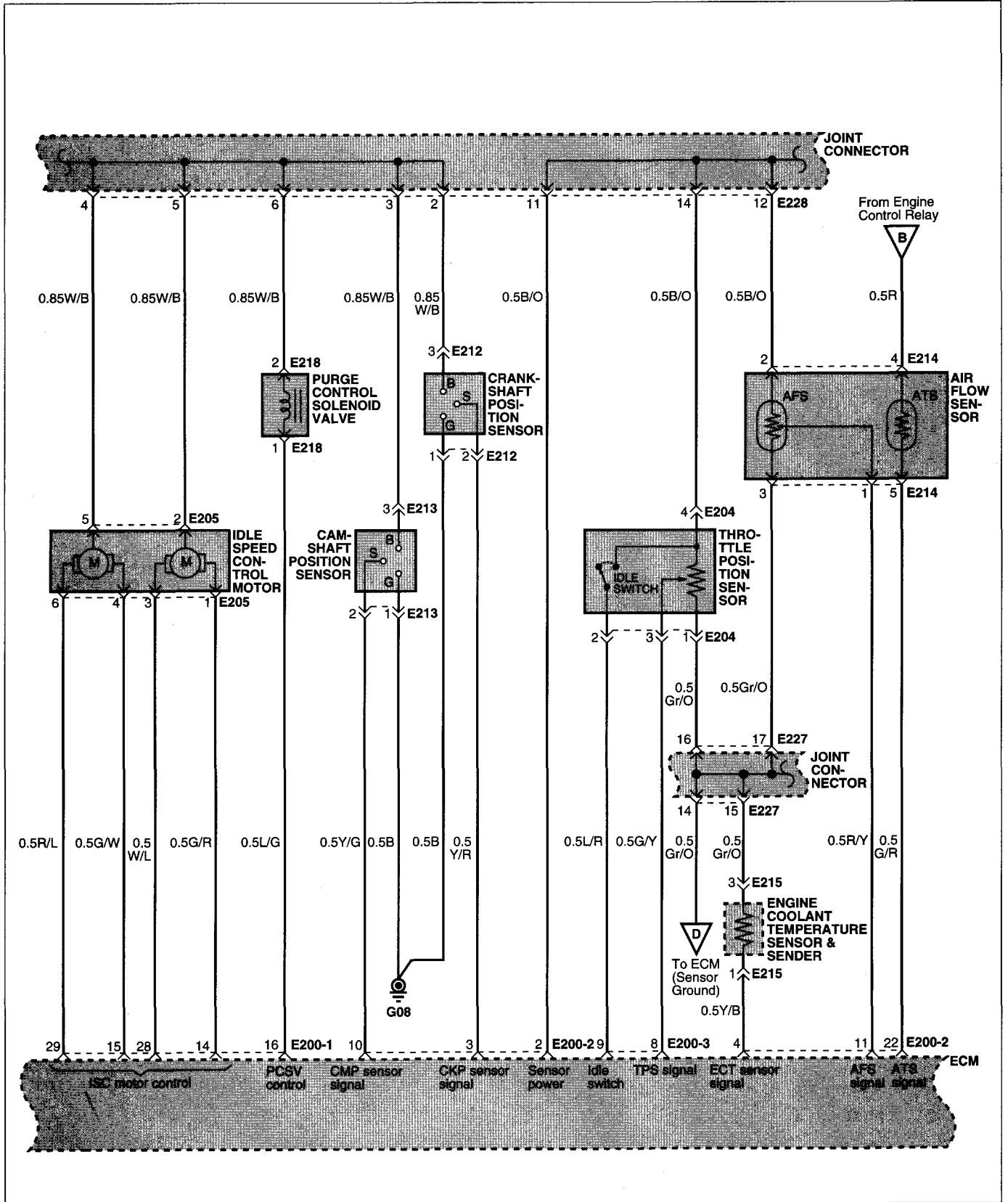

MFI CONTROL SYSTEM (GASOLINE) (6)

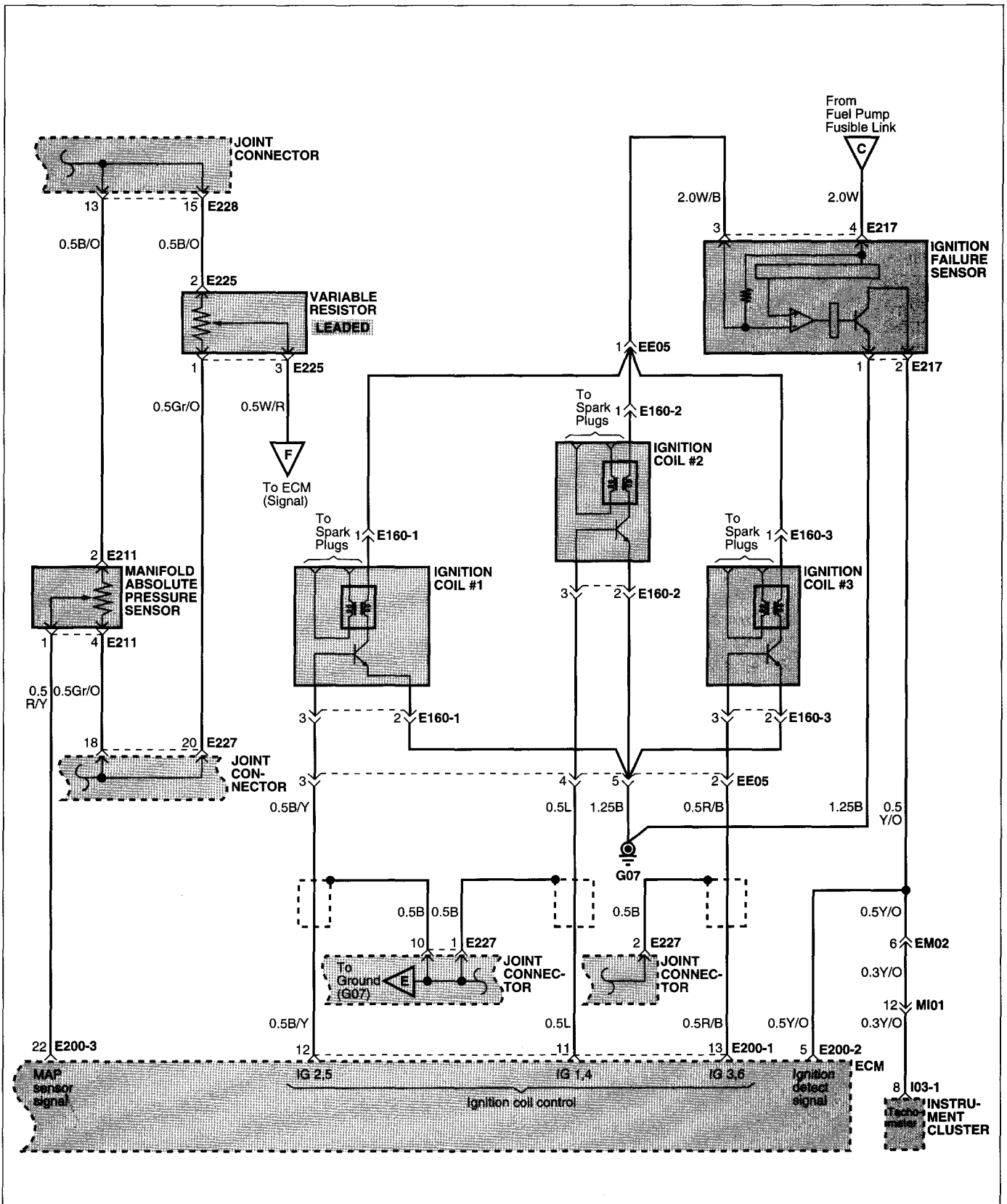

COMPONENT LOCATION INDEX

Components		Location reference - page
E132	Joint connector	CL-14
E160-1	Ignition coil #1	CL-15
E160-2	Ignition coil #2	CL-15
E160-3	Ignition coil #3	CL-15
E165-1	Injector #1	CL-15
E165-2	Injector #2	CL-15
E165-3	Injector #3	CL-15
E165-4	Injector #4	CL-15
E165-5	Injector #5	CL-15
E165-6	Injector #6	CL-15
E200-1	ECM	CL-16
E200-2	ECM	CL-16
E200-3	ECM	CL-16
E201	Main control relay	CL-16
E203	Fuel pump relay	CL-16
E204	Throttle position sensor	CL-16
E205	Idle speed control motor	CL-16
E207	Left rear oxygen sensor (B2/S2)	CL-16
E208	Right rear oxygen sensor (B1/S2)	CL-16
E209	Right front oxygen sensor (B1/S1)	CL-16
E210	Power steering switch	CL-16
E211	Manifold absolute pressure sensor	CL-16
E212	Crankshaft position sensor	CL-16
E213	Camshaft position sensor	CL-16
E214	Air flow sensor	CL-17
E215	Engine coolant temperature sensor & sender	CL-16
E216	Knock sensor	CL-17
E217	Ignition failure sensor	CL-17
E218	Purge control solenoid valve	CL-17
E220	Left front oxygen sensor	CL-17
E223	VI solenoid	CL-17
E227	Joint connector	CL-18
E228	Joint connector	CL-18
E229	Joint connector	CL-18
I03-1	Instrument cluster	CL-20
I03-3	Instrument cluster	CL-20
M05	Ignition switch	CL-2
M14	Data link connector	CL-2
M15	Multipurpose check connector	CL-2
M20-1	TCM	CL-3
M22-2	TOD control module	CL-3
M55	Immobilizer control module	CL-5
R05	Fuel tank	CL-24

COMPONENT LOCATION INDEX

Connectors	Location reference - page
EE05	CL-19
EE06	CL-19
EM01	CL-19
EM02	CL-19
EM05	CL-19
MI01	CL- 6
MR01	CL- 7
Grounds	
G07	CL-29
G08	CL-29
G15	CL-30

Circuit Description

The Multiport Fuel Injection (MFI) control system is an electronic fuel metering system with fuel injectors located near the inlet ports of each cylinder. The amount of fuel injection is determined by the ECM according to engine speed and intake air-flow quantity.

The emission control system includes Oxygen sensors and catalytic converters. The MFI's three major functions are to control air-fuel mixture, idle speed and ignition timing. Refer to the shop Manual, section FL for details.

FUEL HEATER CONTROL SYSTEM

EBE5A32C

FUEL HEATER CONTROL SYSTEM (1)

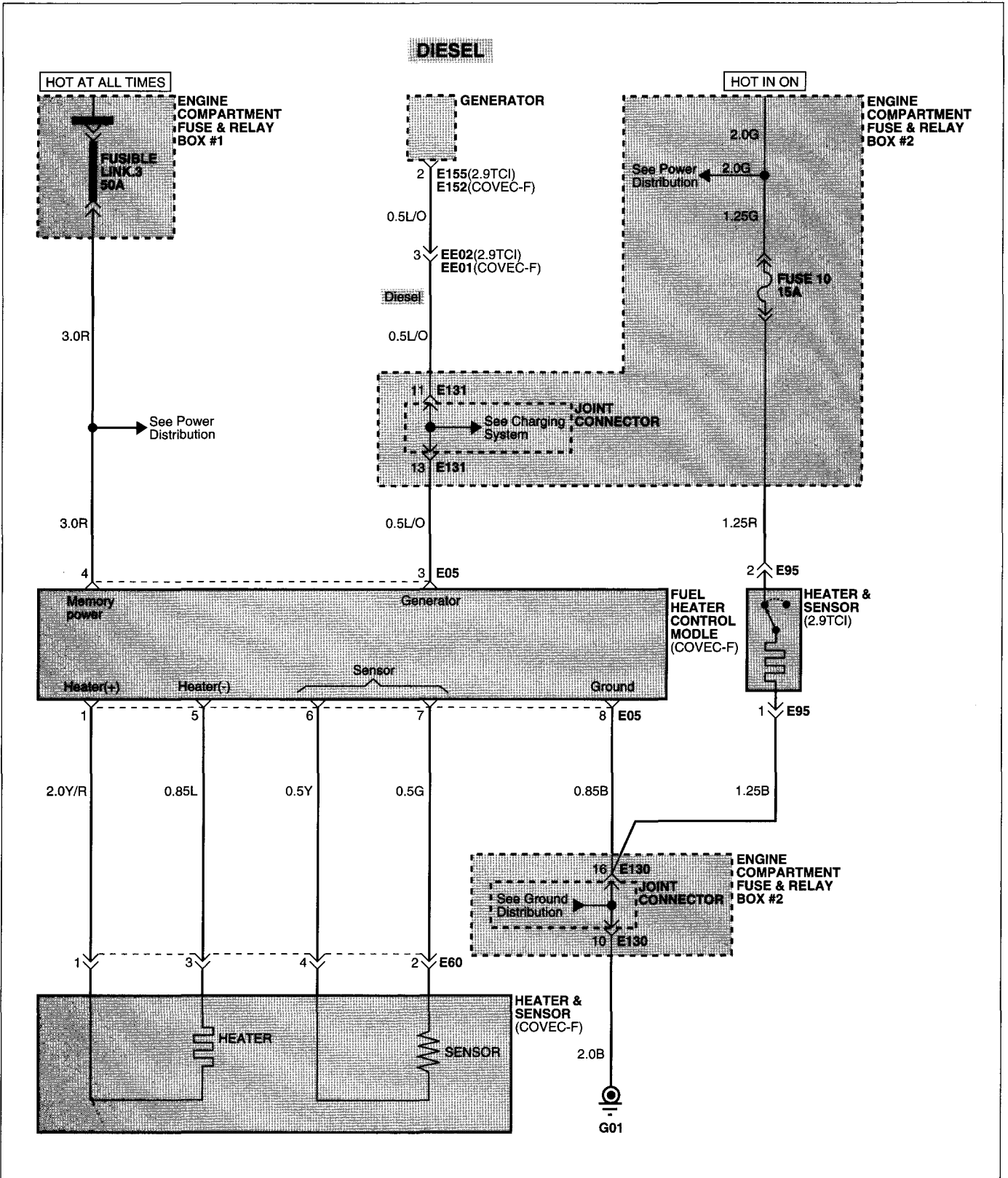

COMPONENT LOCATION INDEX

Components		Location reference - page
E05	Fuel heater control module (COVEC-F)	CL-14
E60	Heater & sensor (COVEC-F)	CL- 8
E95	Heater & sensor (2.9TCI)	CL-12
E130	Joint connector	CL-14
E131	Joint connector	CL-14
E152	Generator (COVEC-F)	CL-15
E155	Generator (2.9TCI)	CL-15
Connectors		
EE01		CL-18
EE02		CL-18
Grounds		
G01		CL-29

AUTOMATIC TRANSAXLE CONTROL SYSTEM

EADBCB2E

AUTOMATIC TRANSAXLE CONTROL SYSTEM (1)

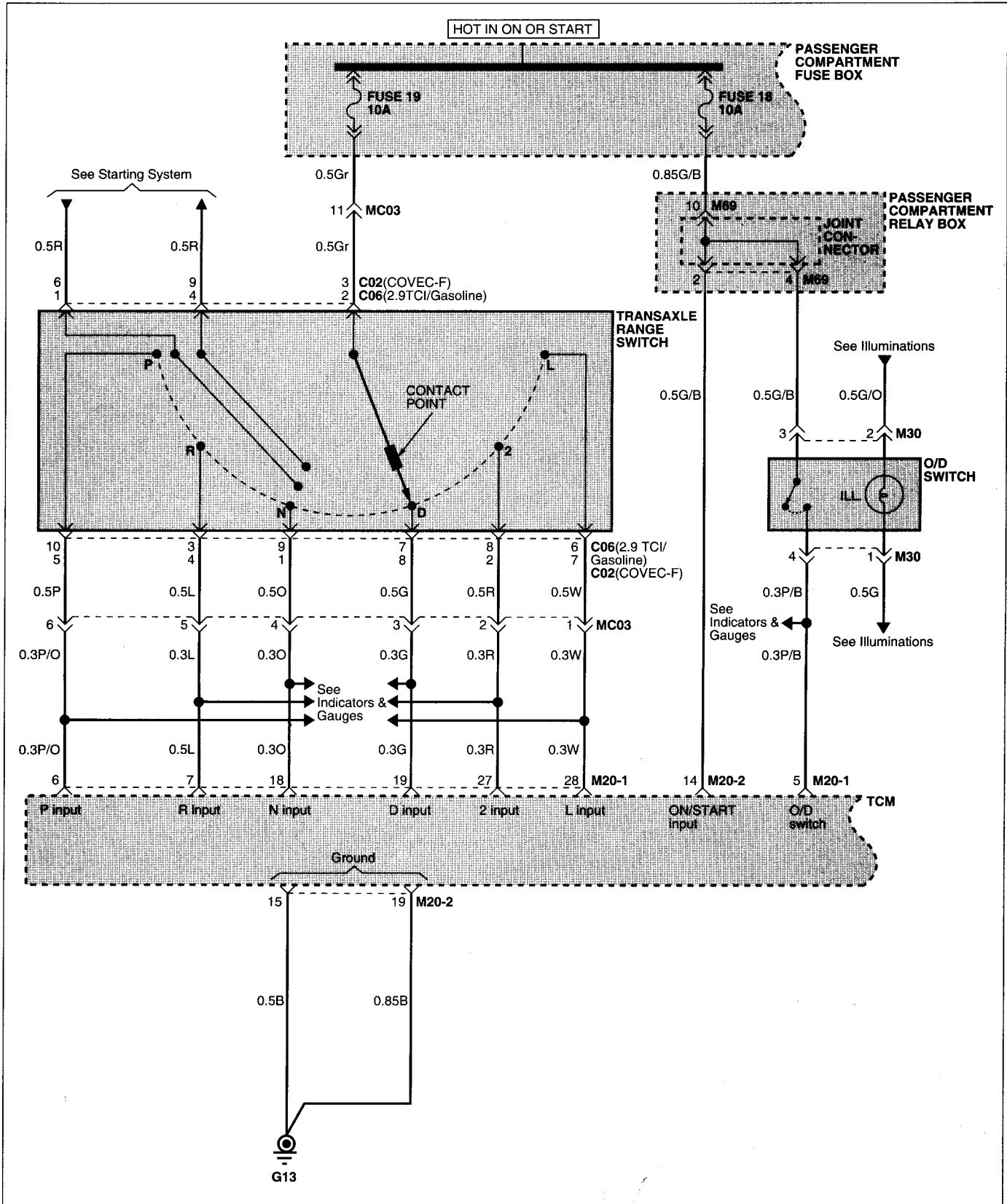

AUTOMATIC TRANSAXLE CONTROL SYSTEM (2)

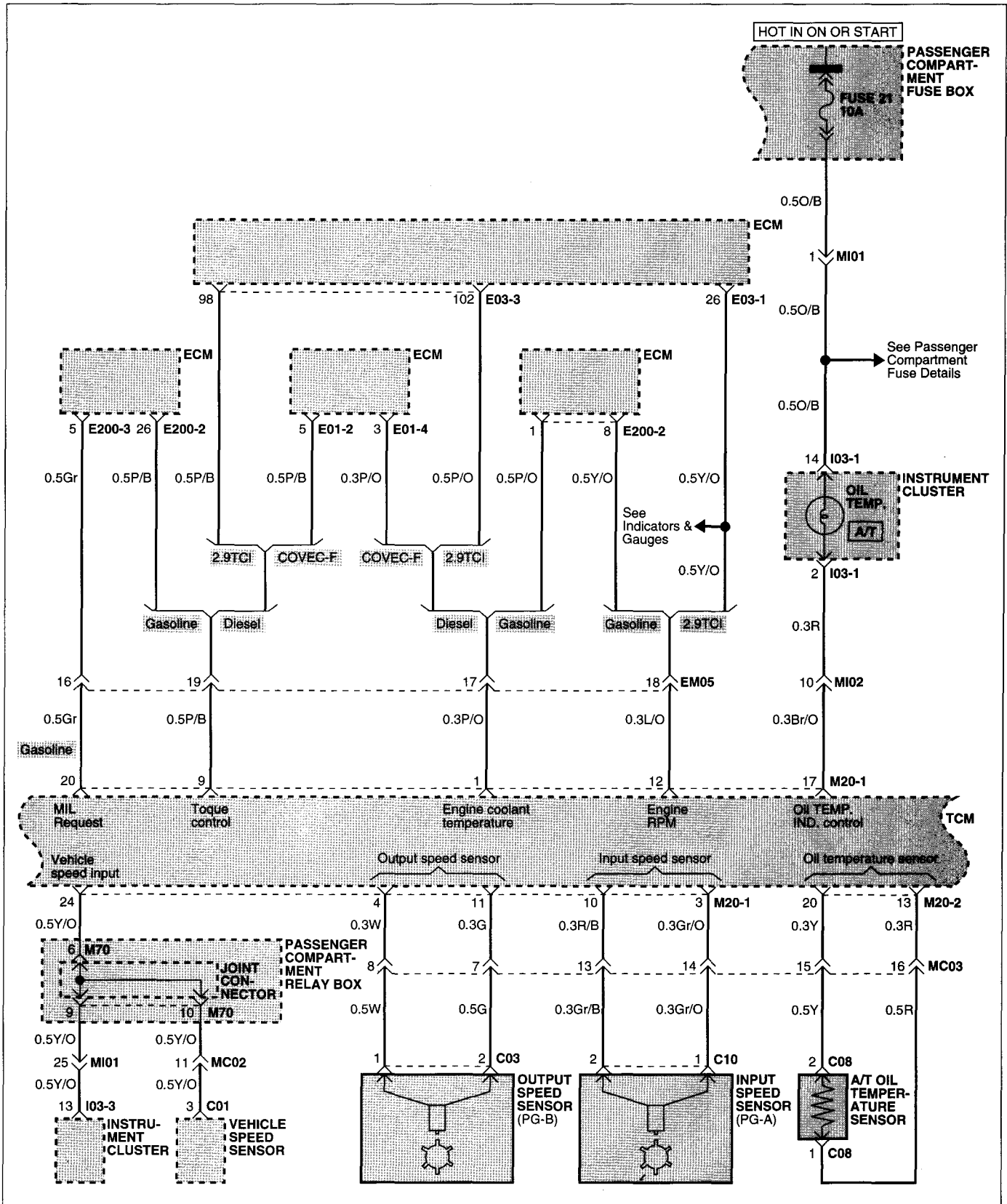

AUTOMATIC TRANSAXLE CONTROL SYSTEM (3)

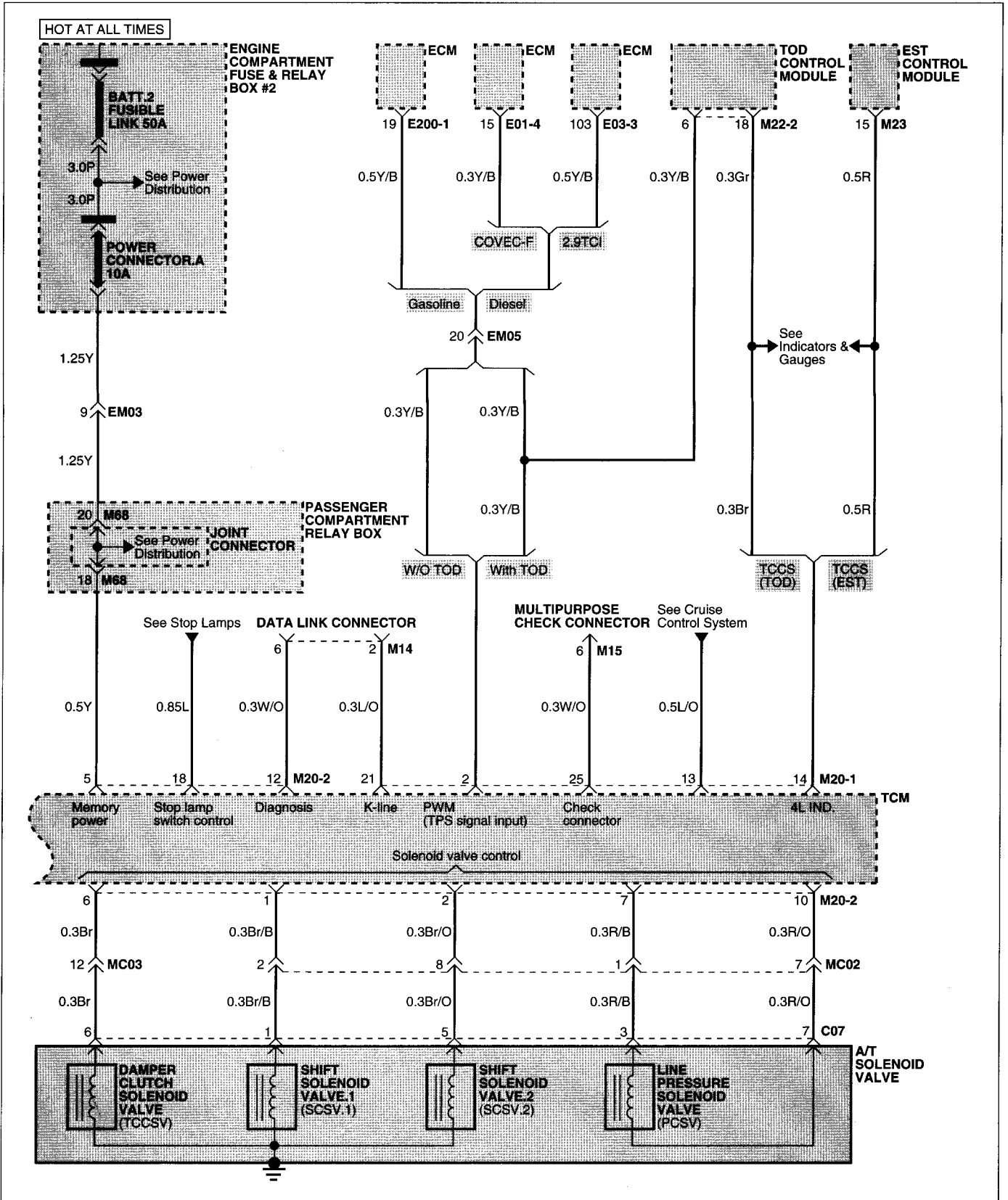

COMPONENT LOCATION INDEX

Components	Location reference - page
C01 Vehicle speed sensor	CL-21
C02 Transaxle range switch (COVEC-F)	CL-21
C03 Output speed sensor (PG-B)	CL-21
C06 Transaxle range switch (Gasoline/2.9TCI)	CL-21
C07 A/T solenoid valve	CL-21
C08 A/T oil temperature sensor	CL-21
C10 Input speed sensor (PG-A)	CL-21
E01-2 ECM (COVEC-F)	CL- 8
E01-4 ECM (COVEC-F)	CL- 8
E03-1 ECM (2.9TCI)	CL- 8
E03-3 ECM (2.9TCI)	CL- 8
E200-1 ECM (Gasoline)	CL-16
E200-2 ECM (Gasoline)	CL-16
E200-3 ECM (Gasoline)	CL-16
I03-1 Instrument cluster	CL-20
I03-3 Instrument cluster	CL-20
M14 Data link connector	CL- 2
M15 Multipurpose check connector	CL- 2
M20-1 TCM	CL- 3
M20-2 TCM	CL- 3
M22-2 TOD control module	CL- 3
M23 EST control module	CL- 3
M30 O/D switch	CL- 4
M68 Joint connector	CL- 5
M69 Joint connector	CL- 5
M70 Joint connector	CL- 5
 Connectors	
EM03	CL-19
EM05	CL-19
MC02	CL- 6
MC03	CL- 6
MI01	CL- 6
MI02	CL- 6
 Grounds	
G13	CL-29

Circuit Description

The transaxle control module (TCM) provides precise gear shift timing and torque converter is locked-up by controlling the operation of the automatic transaxle solenoid valves (shift solenoid valve.1,2, damper clutch solenoid valve, and line pressure solenoid valve).

The TCM operates these solenoid valves based on input signals from the various sensors (for instance, Pulse Generator A and B).

The TCM has a built-in self diagnostic feature. Refer to the Shop Manual, section TR for details.

TCCS (TOD) ED4ABE80

TCCS (TOD) (1)

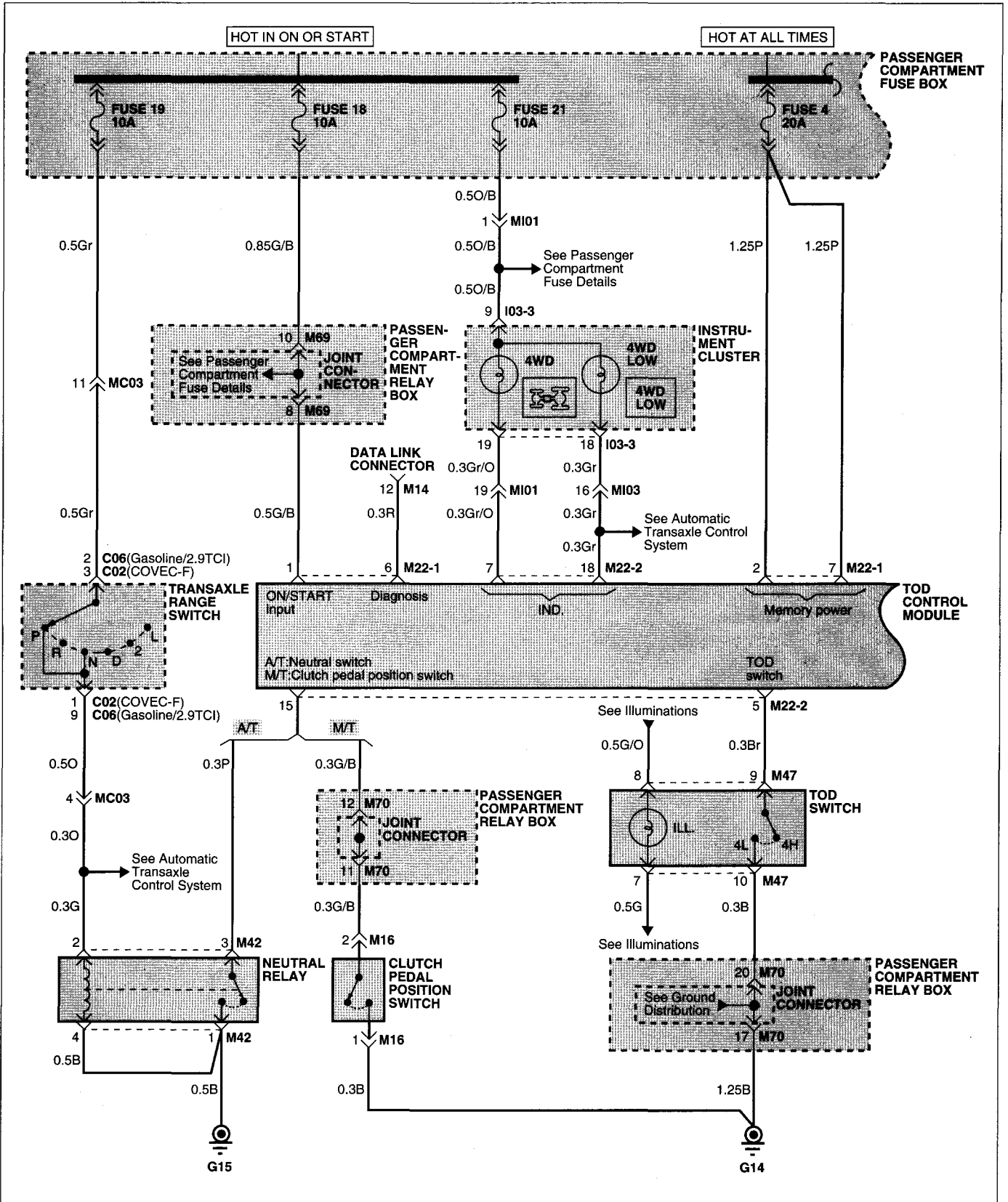

TCCS (TOD) (2)

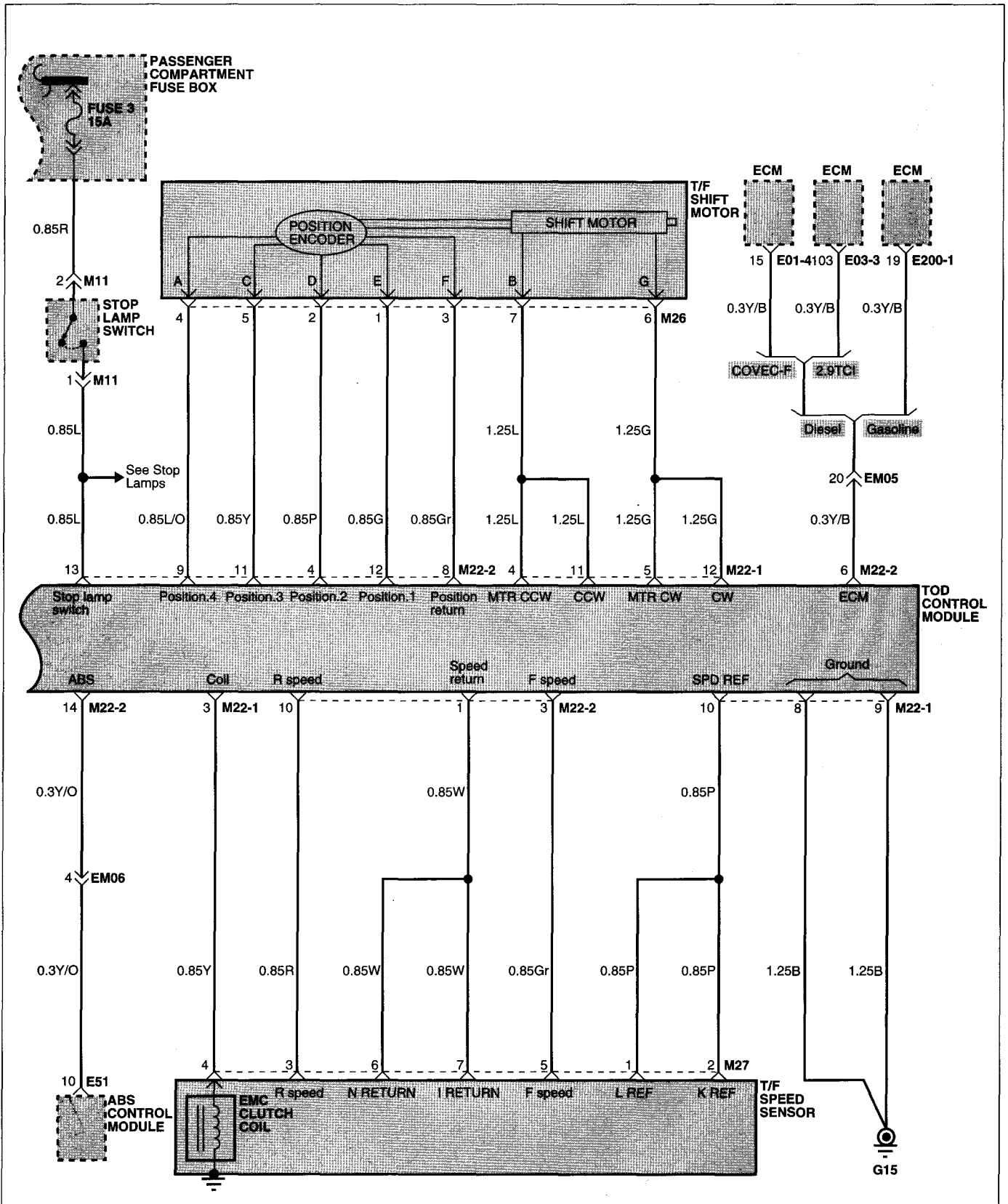

COMPONENT LOCATION INDEX

Components		Location reference - page
C02	Transaxle range switch (COVEC-F)	CL-21
C06	Transaxle range switch (Gasoline/2.9TCI)	CL-21
E51	ABS control module	CL-11
I03-3	Instrument cluster	CL-20
M11	Stop lamp switch	CL- 3
M14	Data link connector	CL- 2
M16	Clutch pedal position switch	CL- 3
M22-1	TOD control module	CL- 3
M22-2	TOD control module	CL- 3
M26	T/F shift motor	CL- 4
M27	T/F speed sensor	CL- 4
M42	Neutral relay	CL- 4
M47	TOD switch	CL- 4
M69	Joint connector	CL- 5
M70	Joint connector	CL- 5
Connectors		
MC03		CL- 6
MI01		CL- 6
MI03		CL- 6
Grounds		
G14		CL-29
G15		CL-30

Circuit Description

TOD (Torque ON Demand) system have 2 drive modes like auto and low.

For the more detail description about this system, please refer to Group TR-section.

TCCS (EST) E7EF2C9F

TCCS (EST) (1)

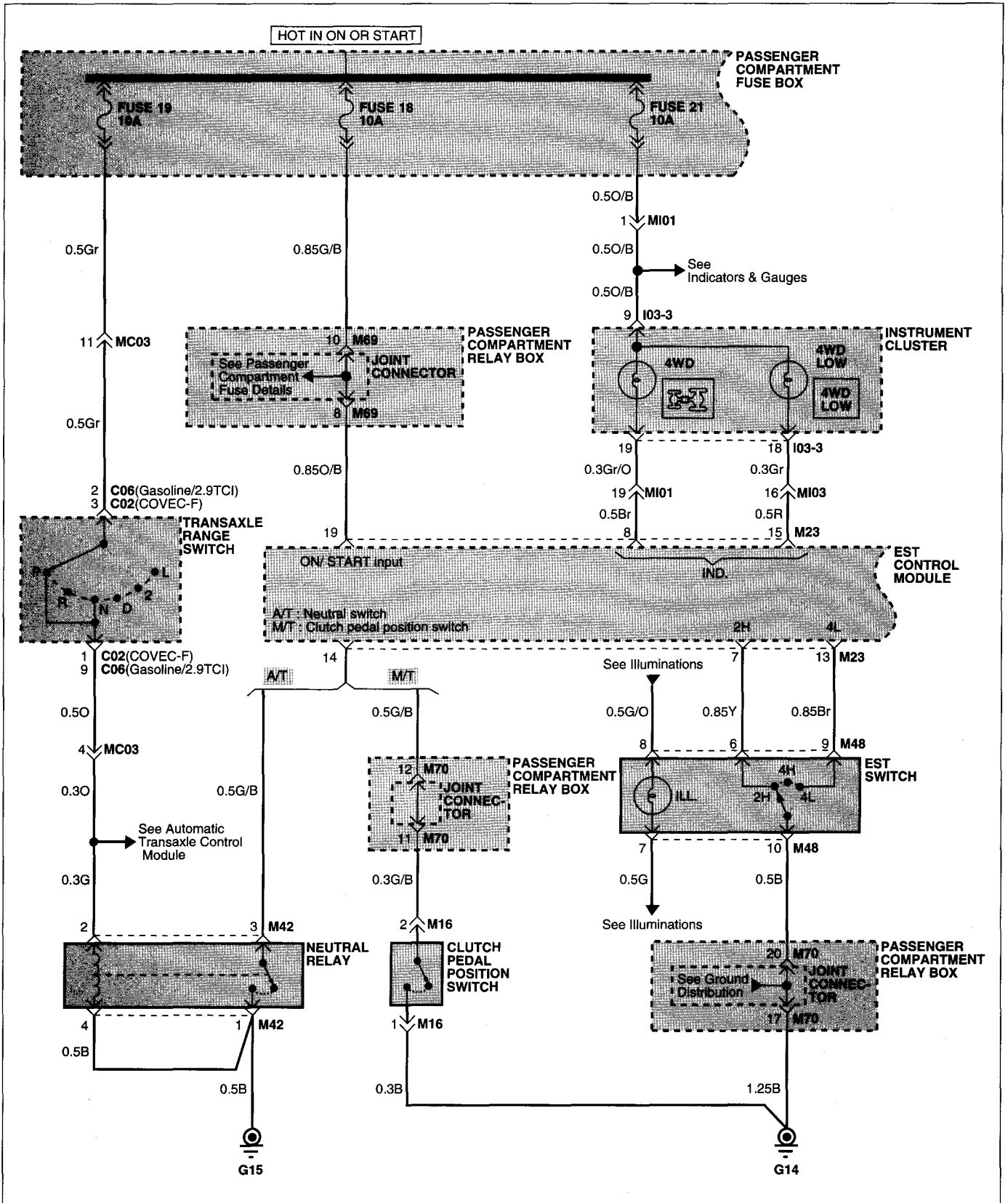

TCCS (EST) (2)

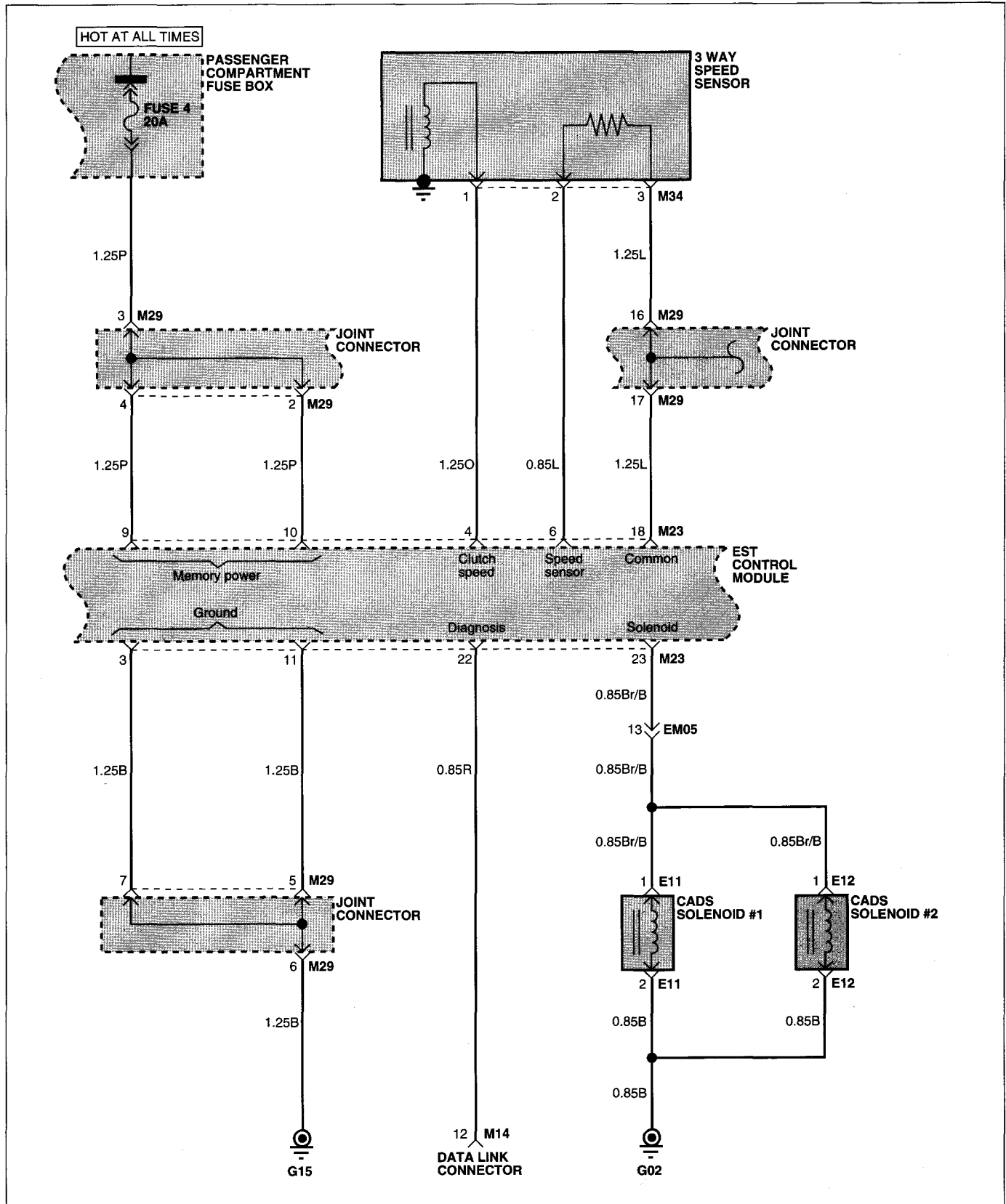

TCCS (EST) (3)

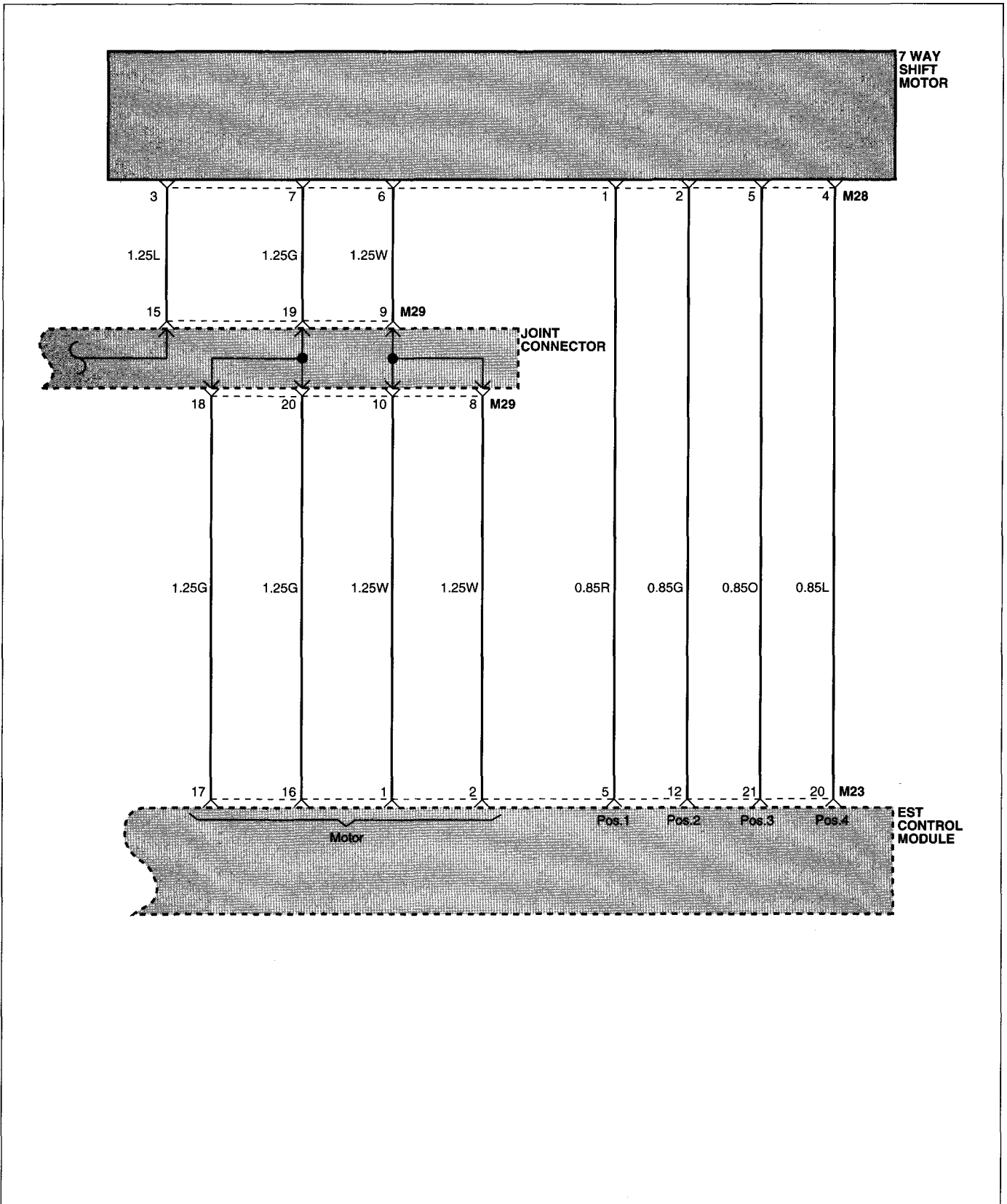

COMPONENT LOCATION INDEX

Components		Location reference - page
C02	Transaxle range switch (COVEC-F)	CL-21
C06	Transaxle range switch (Gasoline/2.9TCI)	CL-21
E11	GADS solenoid #1	CL- 8
E12	GADS solenoid #2	CL- 8
I03-3	Instrument cluster	CL-20
M14	Data link connector	CL- 2
M16	Clutch pedal position switch	CL- 3
M23	ETS control module	CL- 3
M28	7 way shift motor	CL- 4
M29	Joint connector	CL- 4
M34	3 way shift motor	CL- 4
M42	Neutral relay	CL- 4
M48	EST switch	CL- 4
M69	Joint connector	CL- 5
M70	Joint connector	CL- 5
Connectors		
EM05		CL-19
MC03		CL- 6
MI01		CL- 6
MI03		CL- 6
Grounds		
G02		CL-29
G14		CL-29
G15		CL-30

Circuit Description

EST (Electric Shift Transfer) system have 3 drive modes like 2H, 4H, and 4L.

For the more detail description about this system, please refer to Group TR-section.

ANTI-LOCK BRAKE SYSTEM

EFBEBEE8

ANTI-LOCK BRAKE SYSTEM (1)

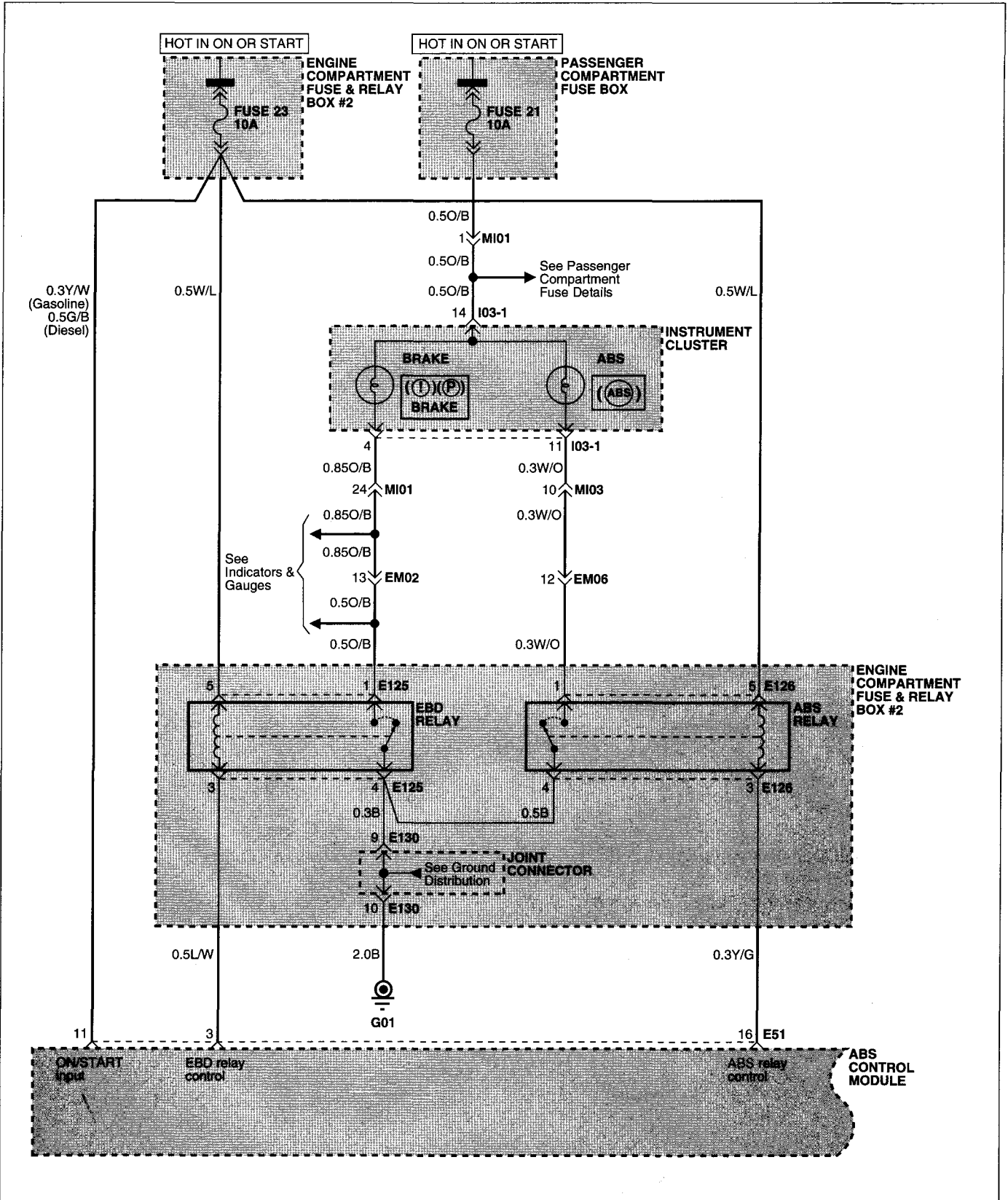

ANTI-LOCK BRAKE SYSTEM (2)

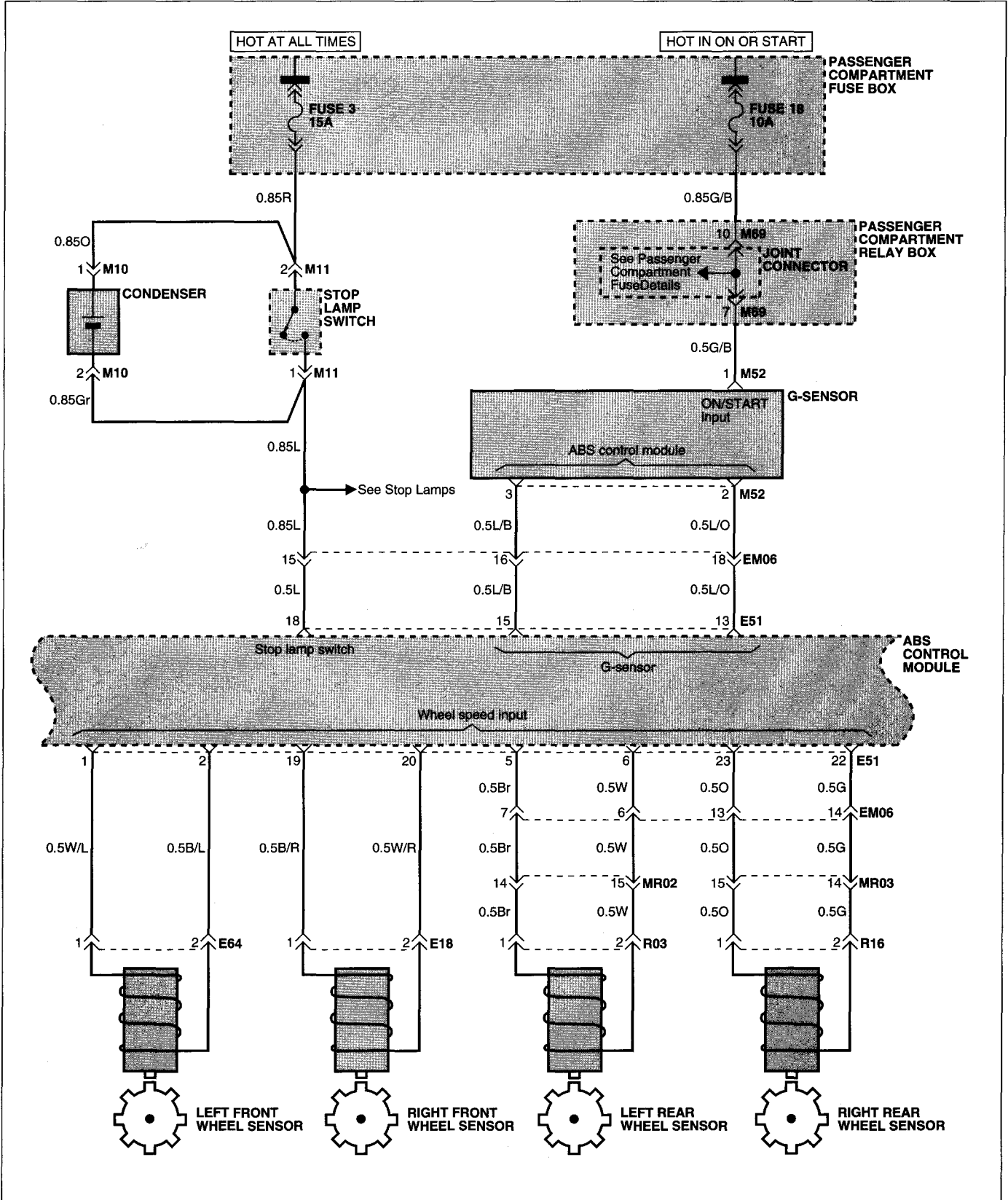

ANTI-LOCK BRAKE SYSTEM (3)

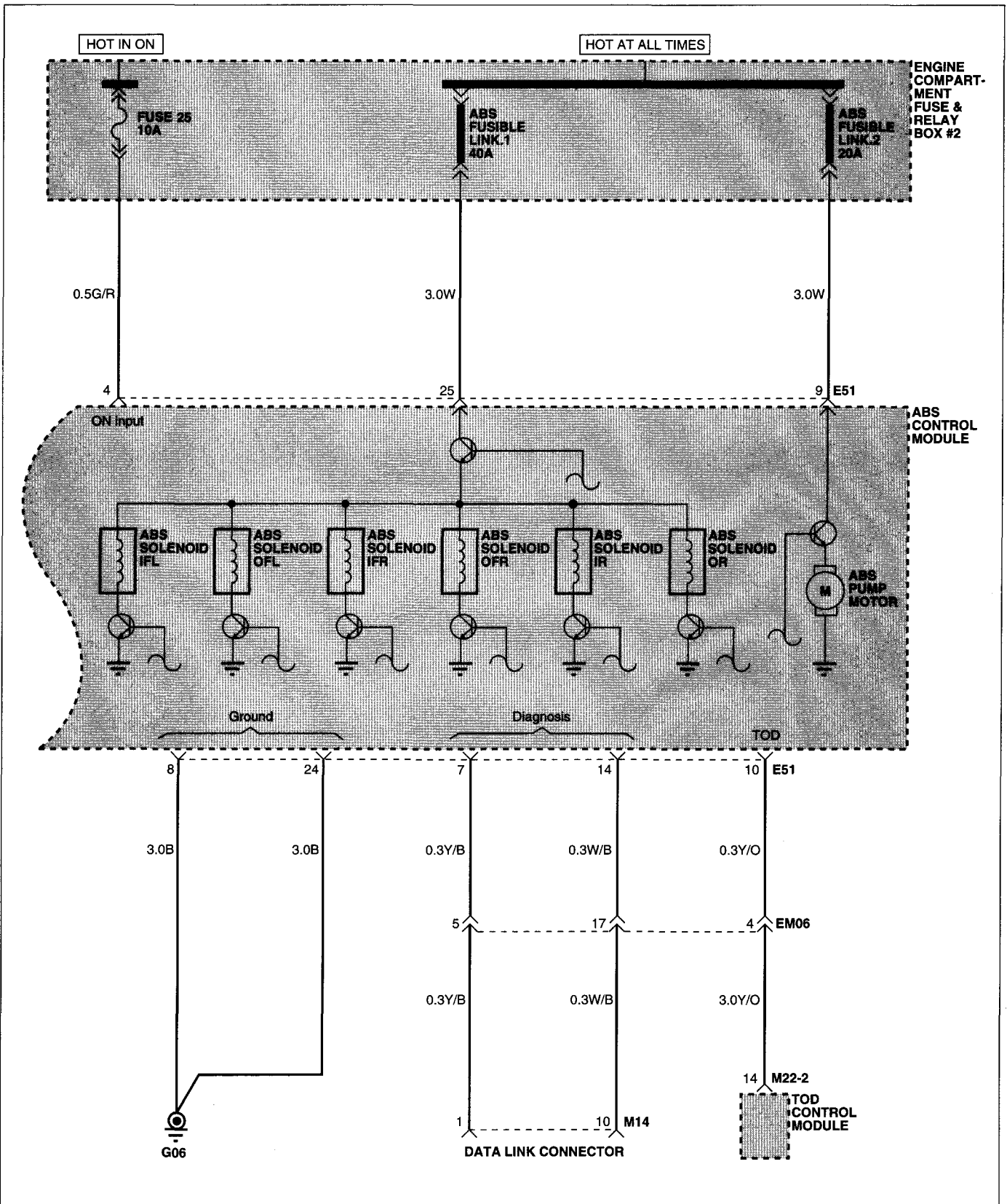

COMPONENT LOCATION INDEX

Components		Location reference - page
E18	Right front wheel sensor	CL- 8
E51	ABS control module	CL-11
E64	Left front wheel sensor	CL-12
E125	EBD relay	CL-14
E126	ABS relay	CL-14
E130	Joint connector	CL-14
I03-1	Instrument cluster	CL-20
M10	Condenser	CL- 3
M11	Stop lamp switch	CL- 3
M14	Data link connector	CL- 2
M22-2	TOD control module	CL- 3
M52	G-sensor (ABS)	CL- 4
M69	Joint connector	CL- 5
R03	Left rear wheel sensor	CL-24
R16	Right rear wheel sensor	CL-24
Connectors		
EM02		CL-19
EM06		CL-19
MI01		CL- 6
MI03		CL- 6
MR02		CL- 7
MR03		CL- 7
Grounds		
G01		CL-29
G06		CL-29

Circuit Description

The ABS (Anti-Lock Brake System) control module controls the hydraulic brake pressure of all four wheels during sudden braking and braking on hazardous road surfaces, preventing the wheels from locking.

The ABS provides the following benefits:

- (1) Enables steering around obstacles with a greater degree of certainty during panic braking.
- (2) Enables stopping during panic braking while allowing stability and control even on curves.

In case a malfunction occurs in the anti-lock brake system, the system will operate as a normal brake system (fail-safe mode). A diagnosis function and fail-safe system have been included for serviceability.

Refer to the shop manual, section BR for details.

IMMOBILIZER CONTROL SYSTEM

E9A1CCD5

IMMOBILIZER CONTROL SYSTEM (1)

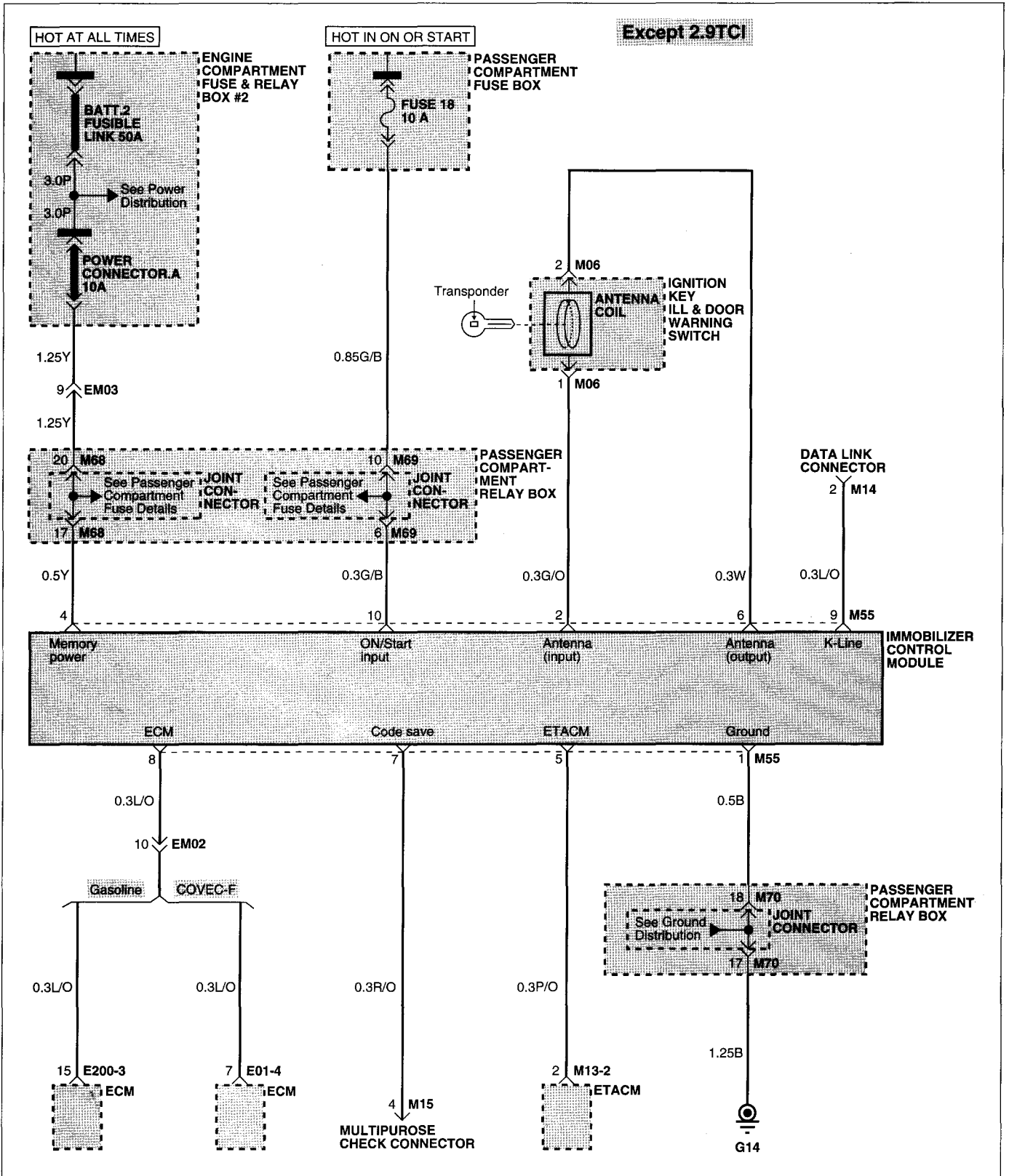

IMMOBILIZER CONTROL SYSTEM (2)

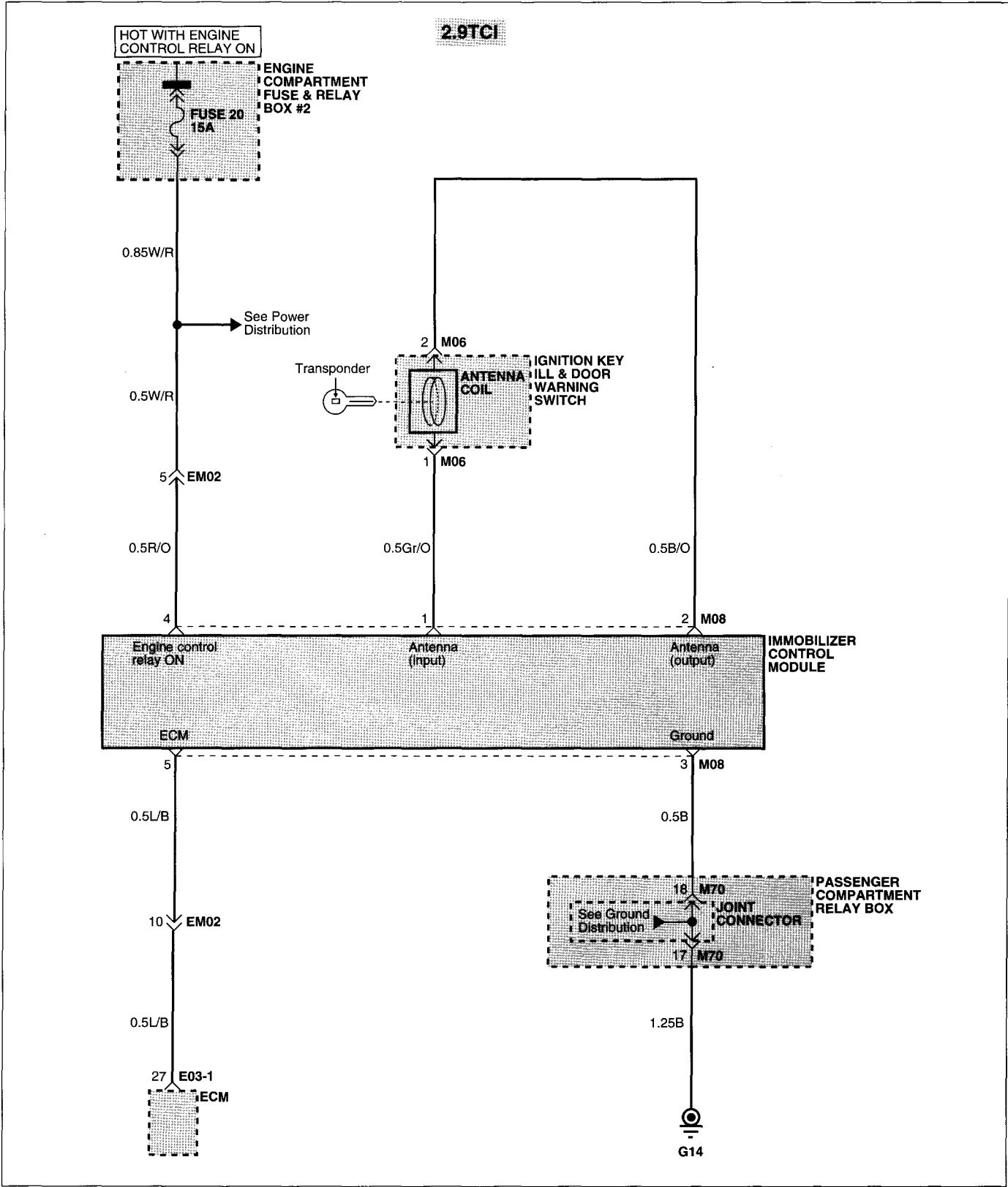

COMPONENT LOCATION INDEX

Components		Location reference - page
E01-4	ECM (COVEC-F)	CL- 8
E03-1	ECM (2.9TCI)	CL- 8
E200-3	ECM (Gasoline)	CL-16
M06	Ignition key ill & door warning switch	CL- 2
M08	Immobilizer control module (2.9TCI)	CL- 2
M13-2	ETACM	CL- 2
M14	Data link connector	CL- 2
M15	Multipurpose check connector	CL- 2
M55	Immobilizer control module (Except 2.9TCI)	CL- 5
M68	Joint connector	CL- 5
M69	Joint connector	CL- 5
M70	Joint connector	CL- 5
Connectors		
EM02		CL-19
EM03		CL-19
Grounds		
G14		CL-29

Circuit Description

The immobilizer control system is an anti-theft device which enables the starting to be possible only as the mechanical and wireless secret codes, memorized in the Engine Control Module, and the Immobilizer Control Module (ICM), are aligned simultaneously.

The transponder (built-in the ignition key) sends unique frequency secret code signals to the ICM through Antenna coils. The ICM compares the received code signals with memorized code. When the codes are aligned, the ICM sends signals to the ECM so that the starting is possible through fuel injection control.

CIGARETTE LIGHTER (POWER OUTLET)

EBB774DC

CIGARETTE LIGHTER (POWER OUTLET) (1)

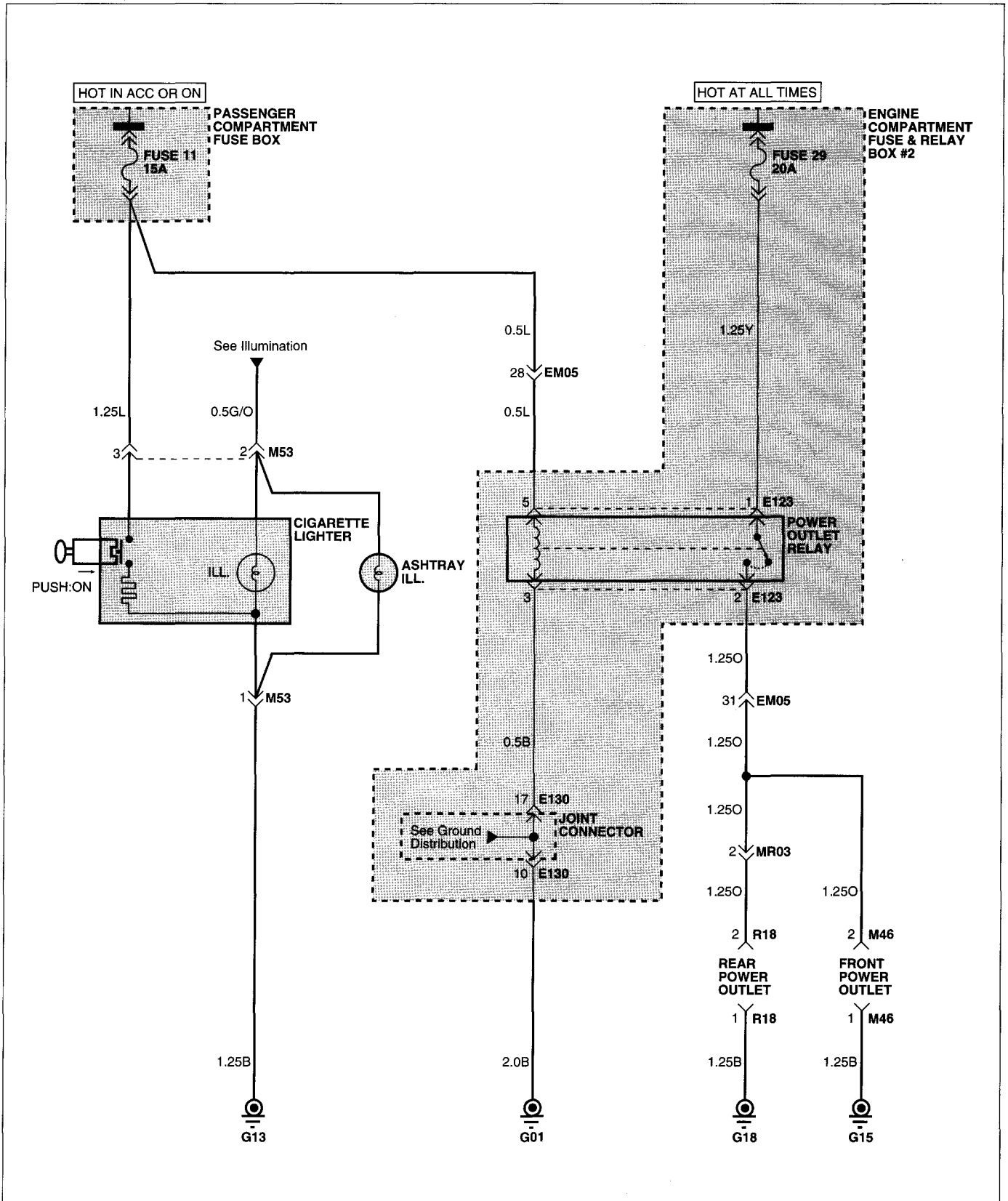

COMPONENT LOCATION INDEX

Components		Location reference - page
E123	Power outlet relay	CL-14
E130	Joint connector	CL-14
M46	Front power outlet	CL- 4
M53	Cigarette lighter	CL- 4
R18	Rear power outlet	CL-25
Connectors		
EM05		CL-19
MR03		CL- 7
Grounds		
G01		CL-29
G13		CL-29
G15		CL-30
G18		CL-30

Circuit Description

With the ignition switch in ACC or ON, battery voltage is applied from fuse 11 to the cigarette lighter. When you depress (push) the lighter, the lighter element completes the circuit to ground. When the element becomes sufficiently heated, it is spring-released and the circuit opens.

DIGITAL CLOCK EF5DABBB

DIGITAL CLOCK (1)

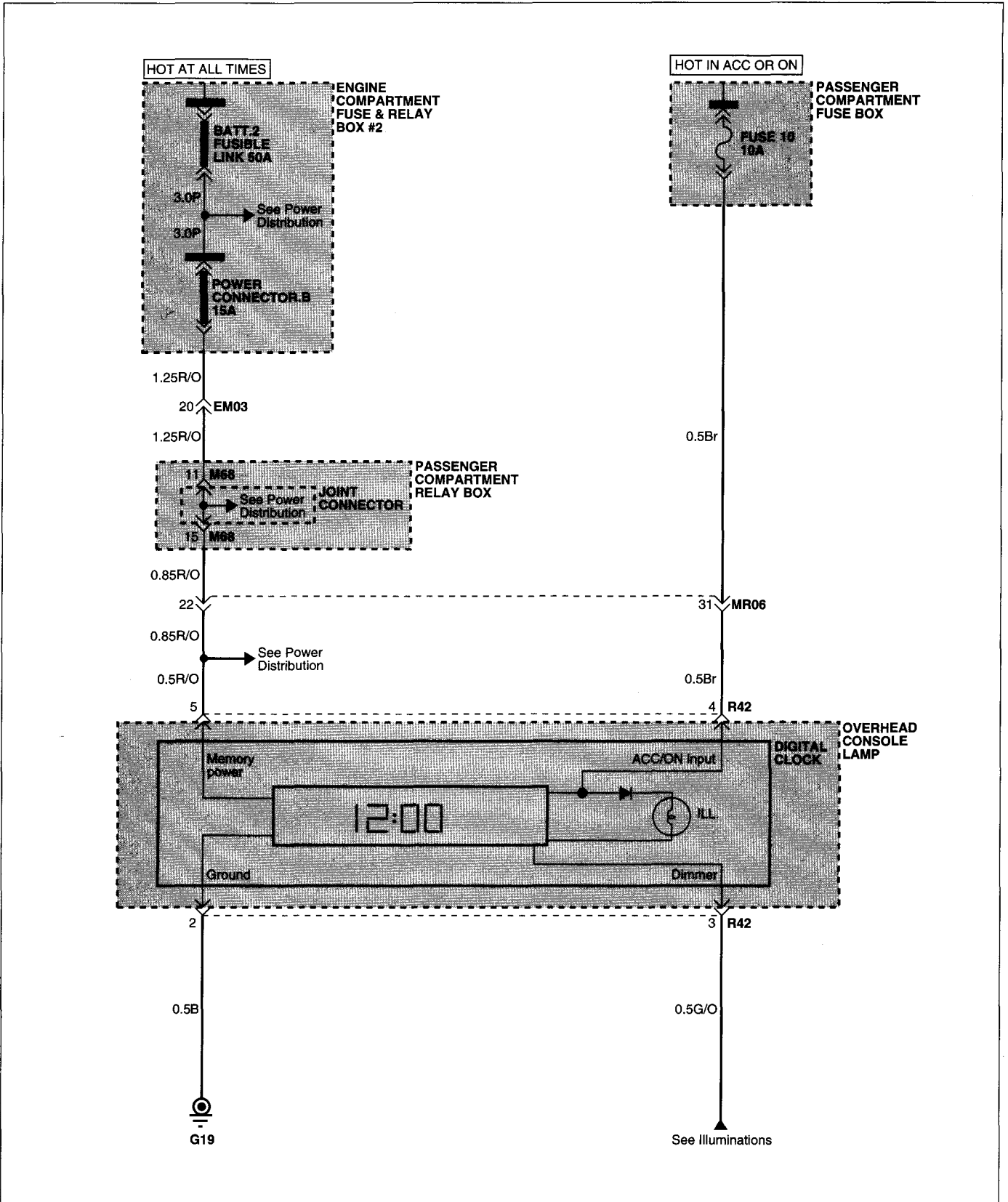

COMPONENT LOCATION INDEX

Components		Location reference - page
M68	Joint connector	CL- 5
R42	Overhead console lamp	CL-26
Connectors		
EM03		CL-19
MR06		CL- 7
Grounds		
G19		CL-30

Circuit Description

Battery voltage is applied at all times to the digital clock in the overhead console lamp from power connector B to maintain clock memory. With the ignition switch in ACC or ON, battery voltage is applied to the clock through fuse 10. The digital clock lights up and displays the time. With the light switch in PARK or HEAD, the light switch provides an additional ground to the digital clock and the digital clock's display will dim.

ETACS (ELECTRONIC TIME & ALARM CONTROL SYSTEM)

E6E3C0A7

ETACS (ELECTRONIC TIME & ALARM CONTROL SYSTEM) (1)

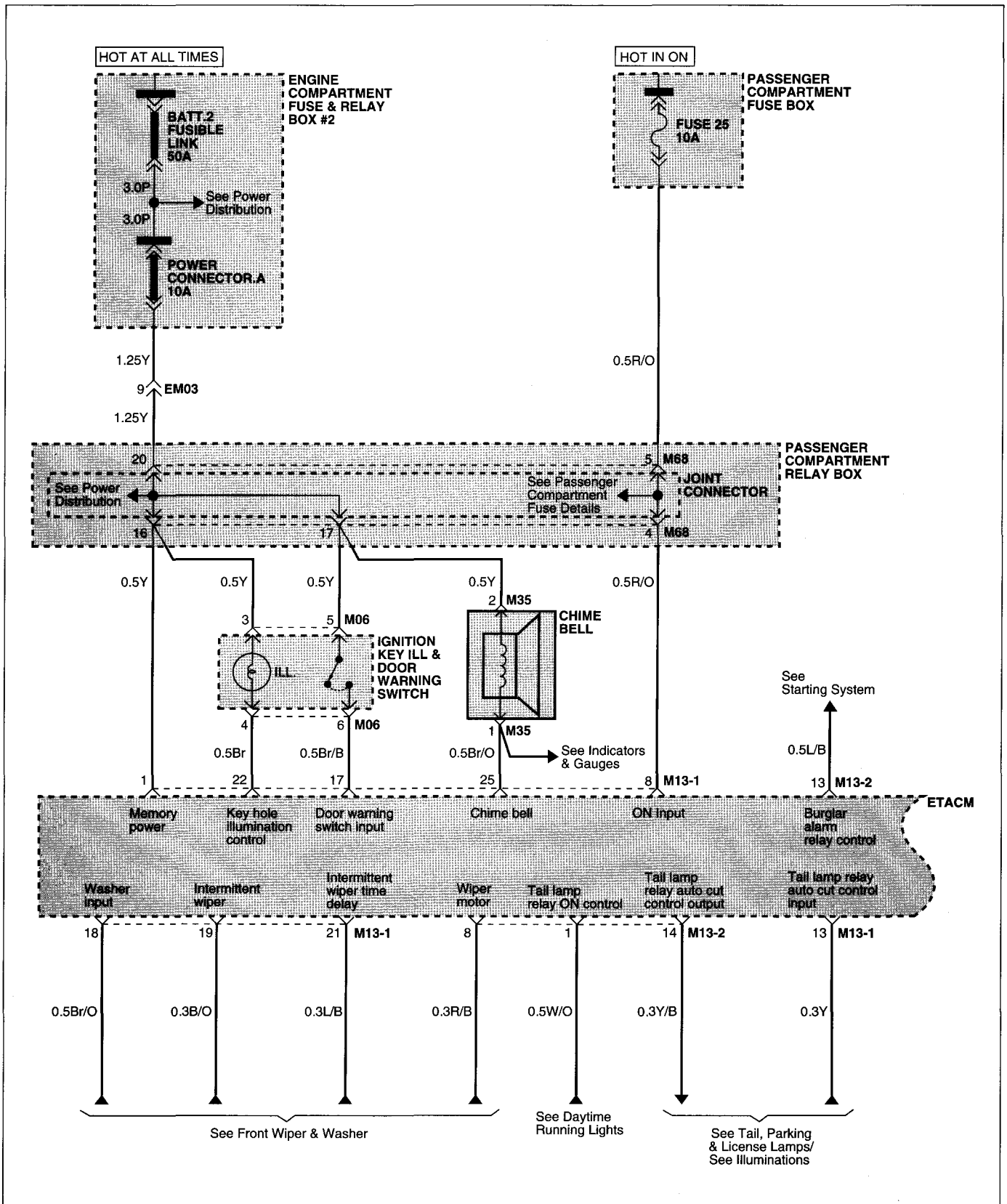

ETACS (ELECTRONIC TIME & ALARM CONTROL SYSTEM) (2)

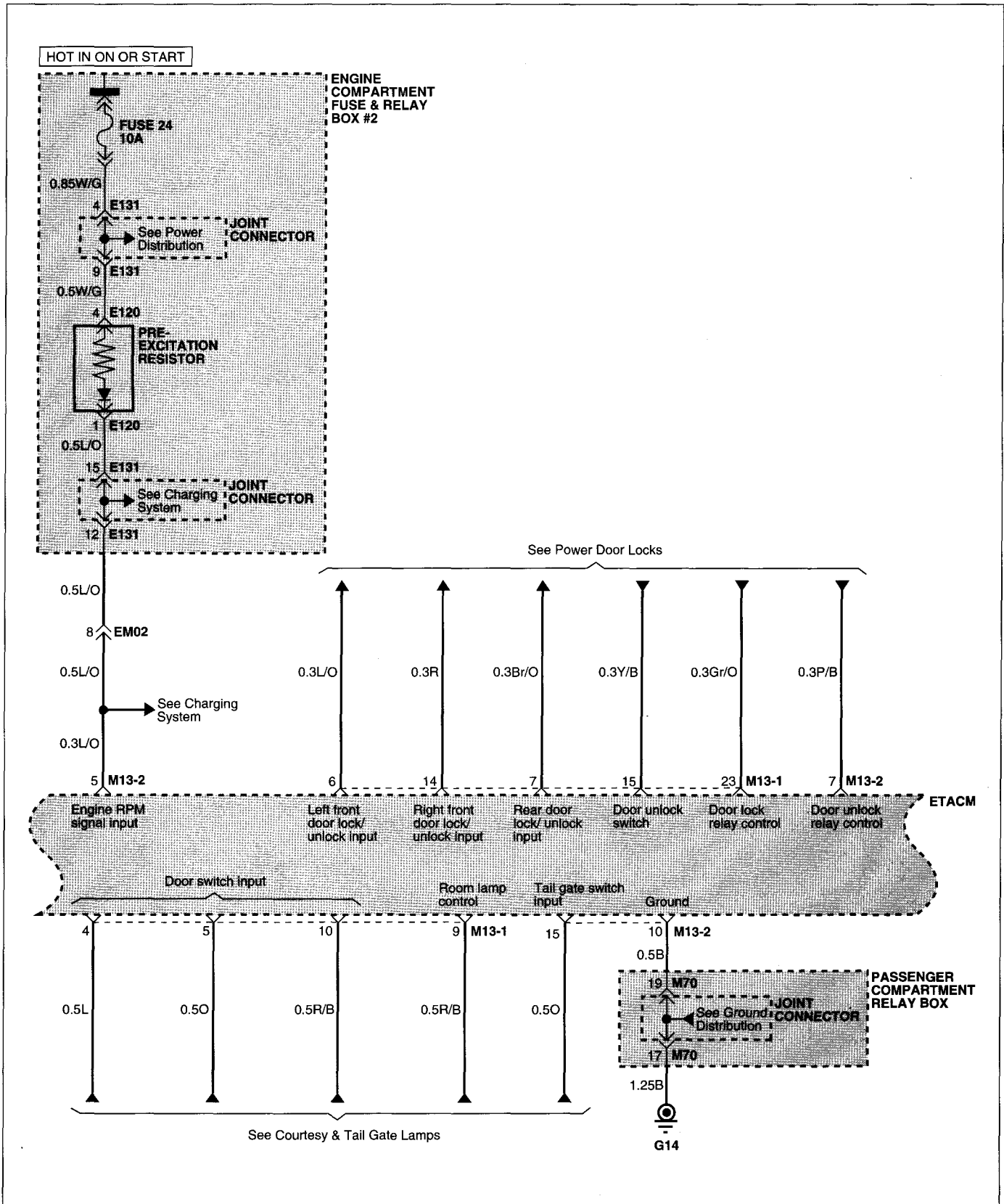

ETACS (ELECTRONIC TIME & ALARM CONTROL SYSTEM) (3)

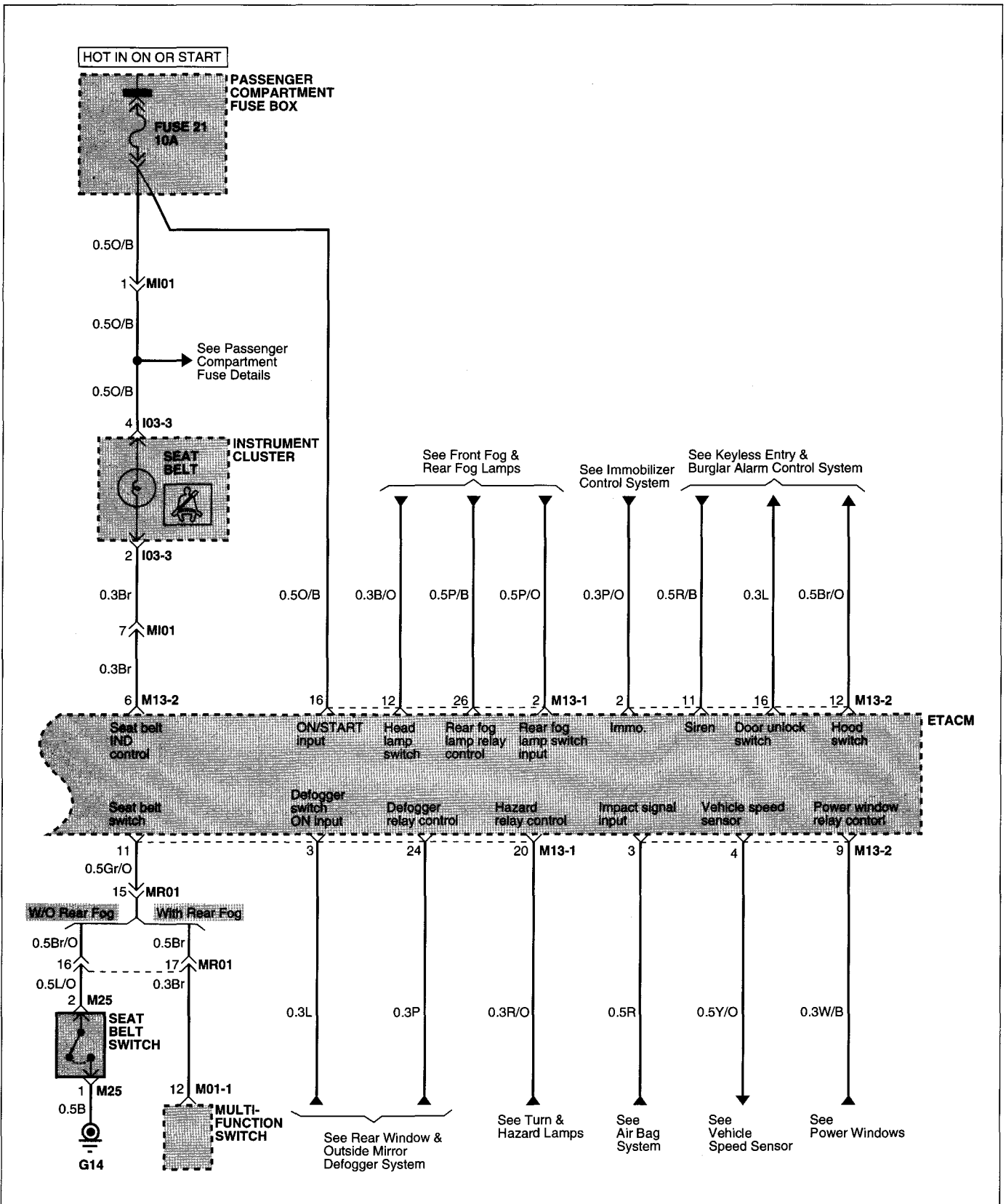

COMPONENT LOCATION INDEX

Components		Location reference - page
E120	Pre-excitation resistor	CL-14
E131	Joint connector	CL-14
I03-3	Instrument cluster	CL-20
M01-1	Multifunction switch	CL- 2
M06	Ignition key ill & door warning switch	CL- 2
M13-1	ETACM	CL- 2
M13-2	ETACM	CL- 2
M25	Seat belt switch	CL- 4
M35	Chime bell	CL- 4
M68	Joint connector	CL- 5
M70	Joint connector	CL- 5
Connectors		
EM02		CL-19
EM03		CL-19
MI01		CL- 6
MR01		CL- 7
Grounds		
G14		CL-29

Circuit Description

The ETACS control module (Electronic Time and Alarm Control System control module) controls the front wiper & washer, chime bell, keyless entry & burglar alarm, power door lock, courtesy and tail gate lamps, rear window defogger & outside mirror defogger, room lamp delay, door warning, seat belt warning, ignition key hole illumination and door key hole illumination.

The module receives battery voltage at all times from power connector A. Fuse 24 supply battery voltage to the module when the ignition switch is in the ON or START position and fuse 25 supply battery voltage to the module when it is in the on position. For details on the use of the various inputs and outputs, refer to the shop Manual, section BE for details.

FRONT WIPER & WASHER E7BF7DE7

FRONT WIPER & WASHER (1)

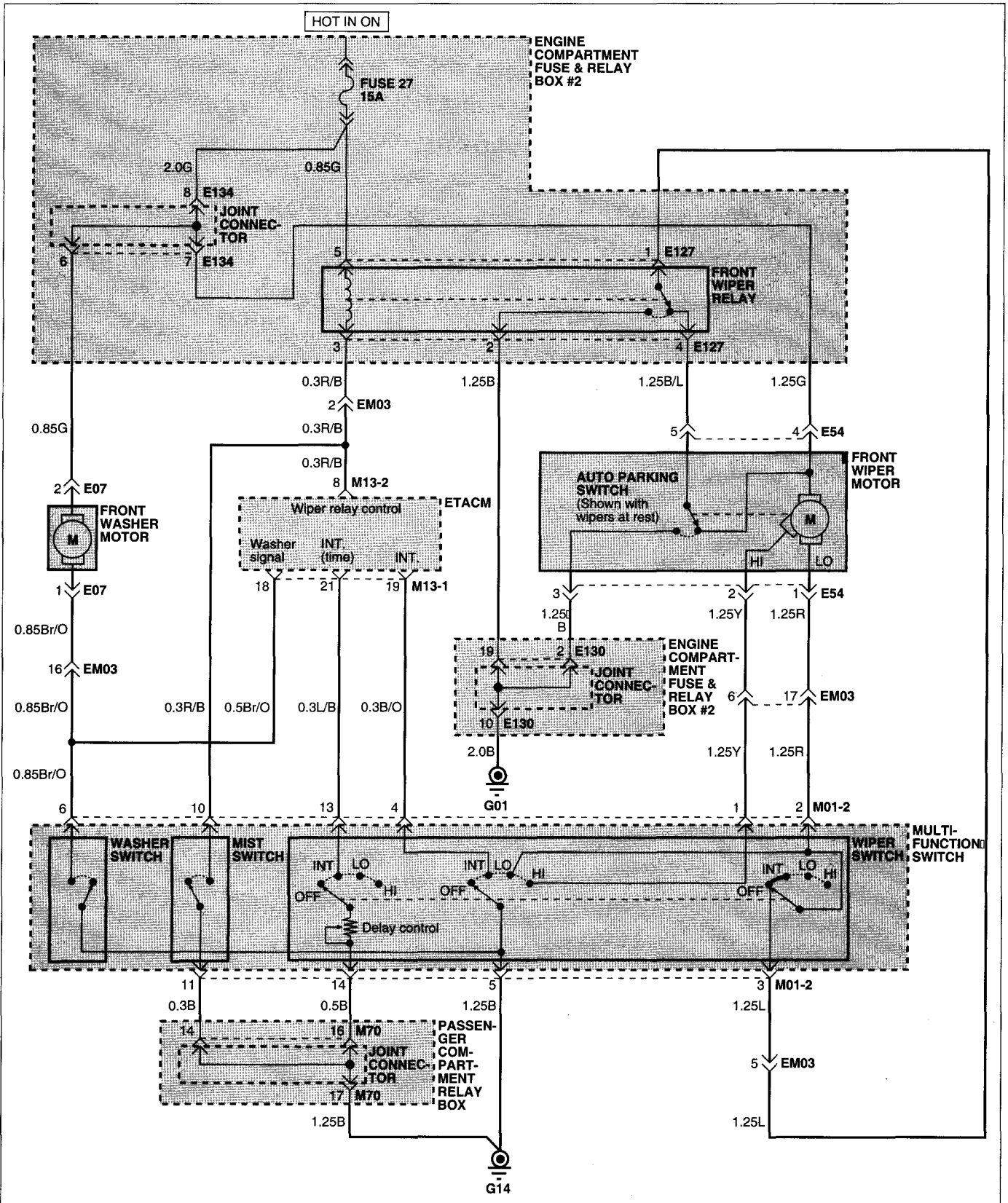

COMPONENT LOCATION INDEX

Components		Location reference - page
E07	Front washer motor	CL- 8
E54	Front wiper motor	CL-11
E127	Front wiper relay	CL-14
E130	Joint connector	CL-14
E134	Joint connector	CL-14
M01-2	Multifunction switch	CL- 2
M13-1	ETACM	CL- 2
M13-2	ETACM	CL- 2
M70	Joint connector	CL- 5
Connectors		
EM03		CL-19
Grounds		
G01		CL-29
G14		CL-29

Circuit Description

All functions of the front wiper and washer circuit are controlled by the position of the front wiper and washer switch. The wiper switch has 4 positions : OFF, INT, LO and HI.

Wiper Operation**1. Low (LO) and High (HI) position**

The front wiper motor has two separate brushes for low and high speed operation. When the wiper switch is in LO or HI, ground is applied to the appropriate brushes through the wiper switch in the multifunction switch.

2. INT position

When the wiper switch is turned to INT, the ETACM receives the INT signal and INT delay time signal. According to these signals, the control module controls the operation of the front wiper through wiper motor relay coil control. Ground is applied to the low speed brush of the front wiper motor through the closed contact of the wiper motor relay.

The remainder of the wiper's sweep is controlled by the auto parking circuit. The cycle repeats as long as the wiper switch is in INT and the pause interval between sweeps is determined by the ETACM.

3. OFF position

When the wiper switch is turned to OFF from other position (INT, LO and HI) and the wiper is not at rest (out of park) position, the low speed brush of the front wiper motor is grounded through the auto parking switch in the front wiper motor and then the wiper goes to the rest (park) position.

Washer Operation

The front wiper motor operates as long as the washer switch is in ON. When the washer switch is pulled, the control module controls the low speed operation of the front wiper motor through the wiper motor relay control.

REAR WIPER & WASHER

E0A5A5BE

REAR WIPER & WASHER (1)

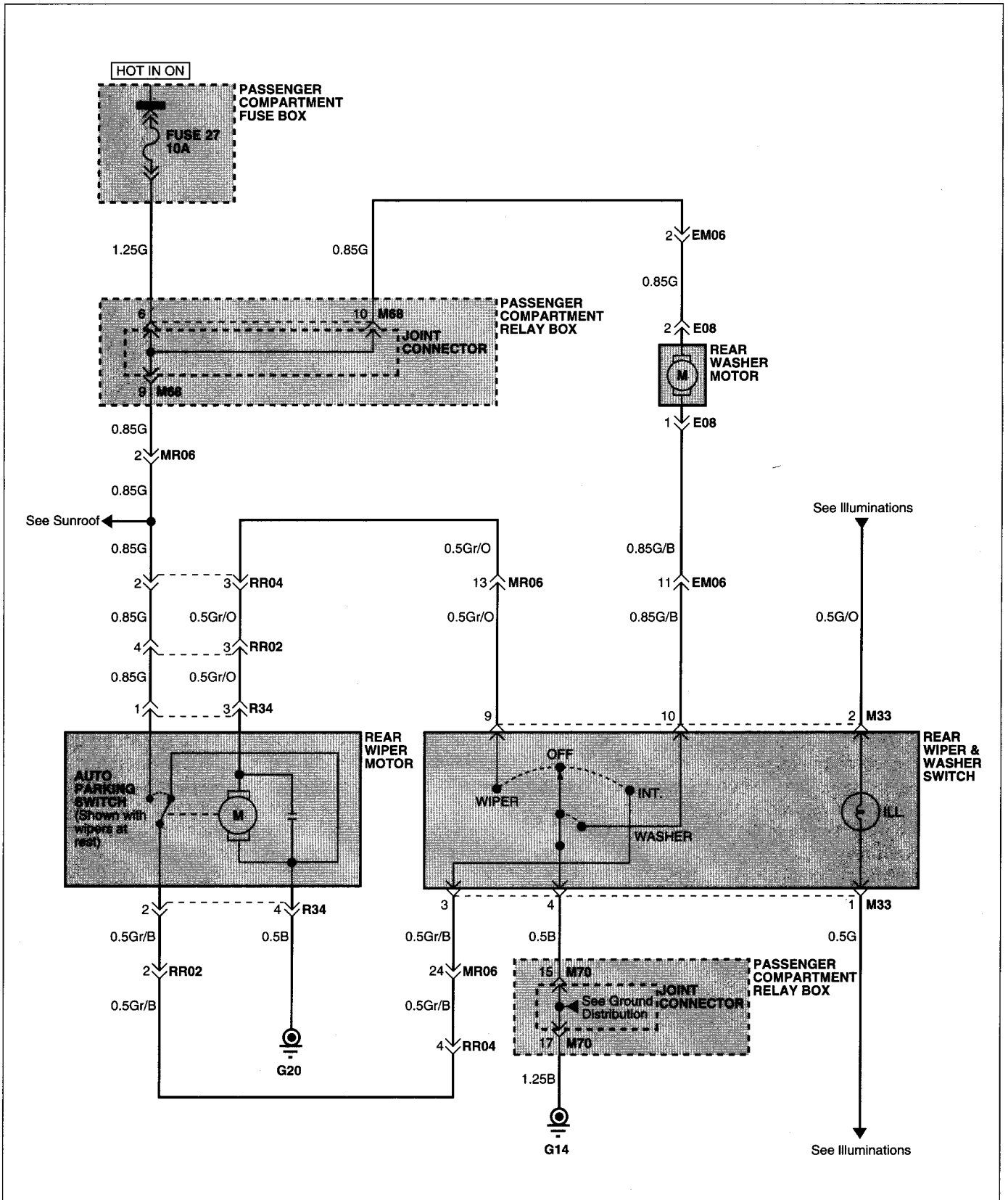

COMPONENT LOCATION INDEX

Components		Location reference - page
E08	Rear washer motor	CL- 8
M33	Rear washer & wiper switch	CL- 4
M68	Joint connector	CL- 5
M70	Joint connector	CL- 5
R34	Rear wiper motor	CL-25
Connectors		
EM06		CL-19
MR06		CL- 7
RR02		CL-26
RR04		CL-26
Grounds		
G14		CL-29
G20		CL-30

Circuit Description

All functions of the rear wiper and washer circuits are controlled by the position of the rear wiper and washer switch.

Rear Wiper Operation

The rear wiper switch has 3 positions (OFF, ON and INT).

1. When the ON position is selected, the rear window wiper operates continuously.
2. When the INT position is selected, the wiper operates intermittently.

Rear Washer Operation

When the WASHER position is selected, the rear wiper operates several times after the washer fluid sprays onto the rear window.

KEYLESS ENTRY & BURGLAR ALARM CONTROL SYSTEM

EE1B26F8

KEYLESS ENTRY & BURGLAR ALARM CONTROL SYSTEM (1)

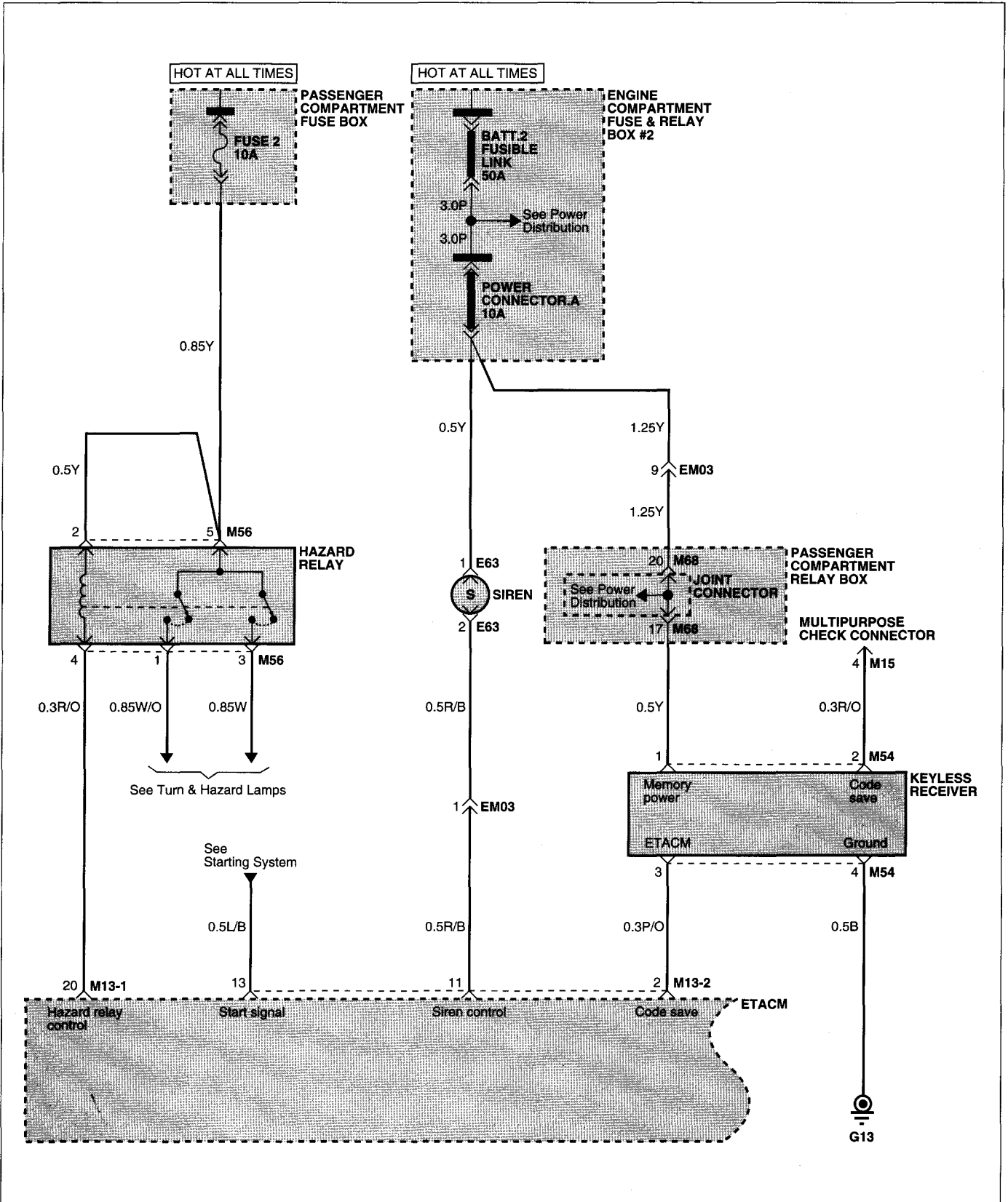

KEYLESS ENTRY & BURGLAR ALARM CONTROL SYSTEM (2)

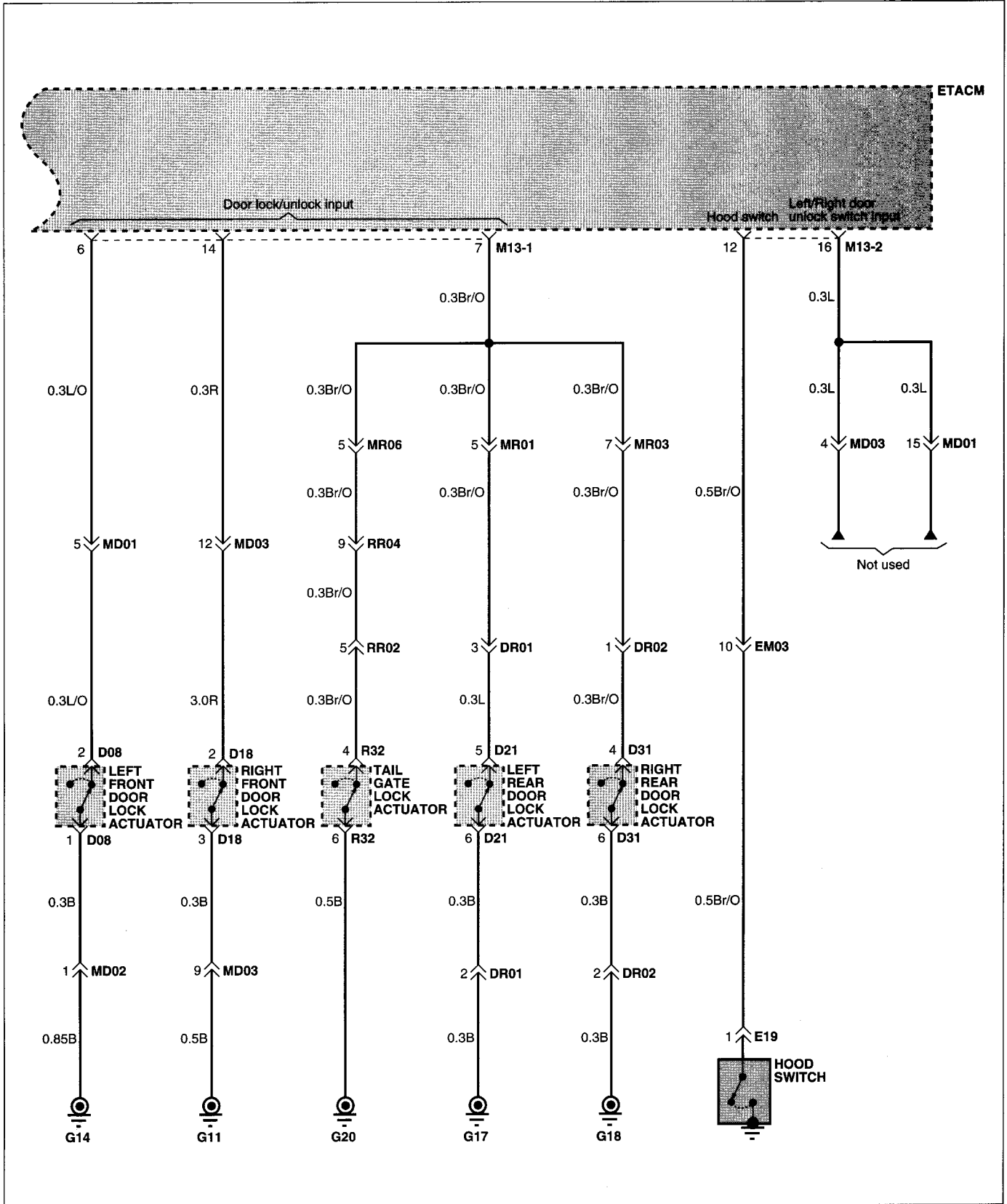

COMPONENT LOCATION INDEX

Components		Location reference - page
D08	Left front door lock actuator	CL-22
D18	Right front door lock actuator	CL-22
D21	Left rear door lock actuator	CL-23
D31	Right rear door lock actuator	CL-23
E19	Hood switch	CL- 9
E63	Siren	CL-12
M13-1	ETACM	CL- 2
M13-2	ETACM	CL- 2
M15	Multipurpose check connector	CL- 2
M54	Keyless receiver	CL- 5
M56	Hazard switch	CL- 5
M68	Joint connector	CL- 5
R32	Tail gate lock actuator	CL-25
 Connectors		
DR01		CL-23
DR02		CL-23
EM03		CL-19
MD01		CL- 6
MD02		CL- 6
MD03		CL- 6
MR01		CL- 7
MR03		CL- 7
MR06		CL- 7
RR02		CL-26
 Grounds		
G11		CL-29
G13		CL-29
G14		CL-29
G17		CL-30
G18		CL-30
G20		CL-30

Circuit Description

The ETACS control module controls the keyless entry system. When the ETACS control module receives code signals from the transmitter, the ETACS control module compares the received code signals with memorized code. If the codes agree, the ETACS control module sends signals to the door modules and turn signal lamps. According to the signals, the turn signal lamps are flashed several times and the door locks are opened.

INDICATORS & GAUGES

EC4A4EDA

INDICATORS & GAUGES (1)

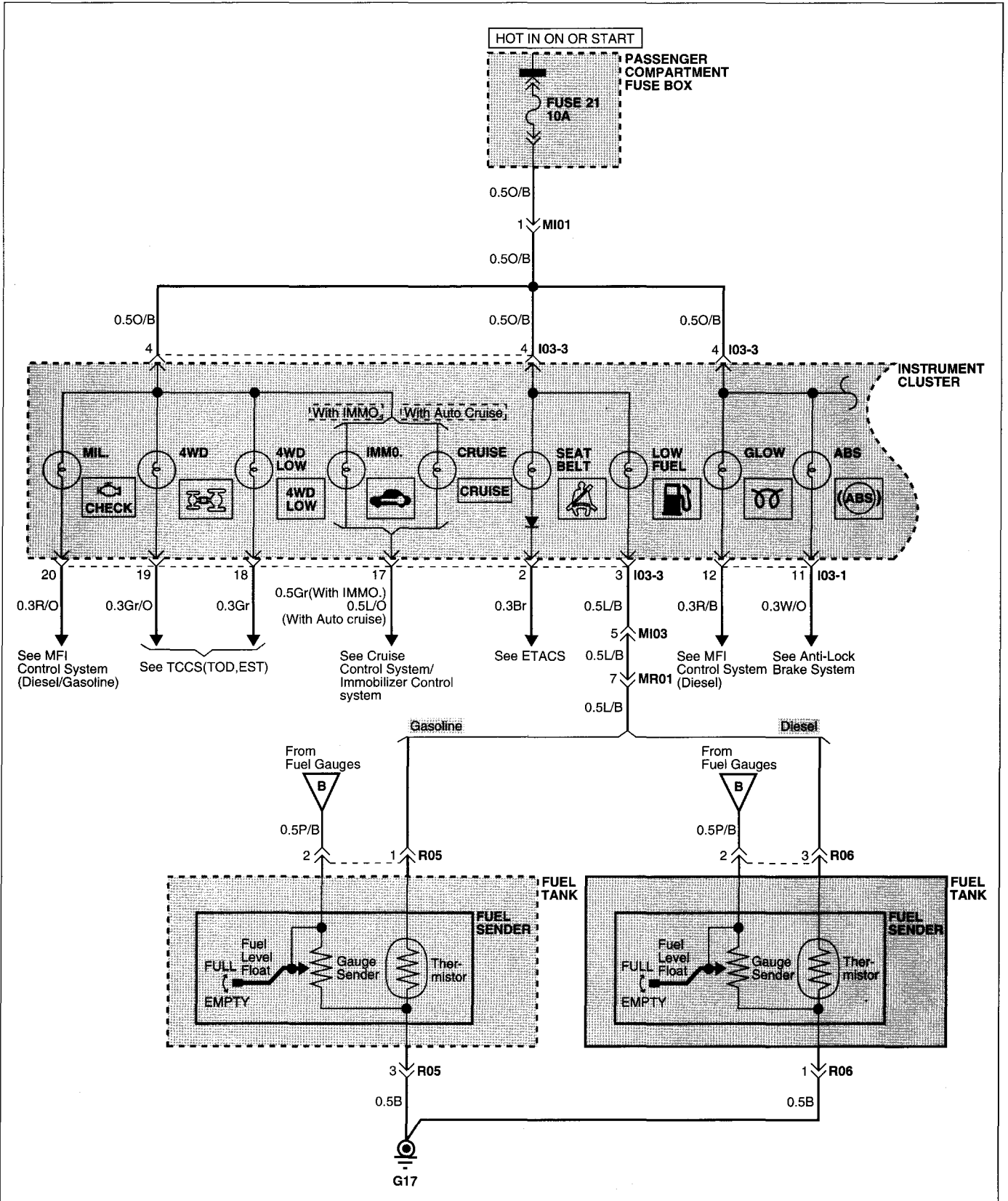

INDICATORS & GAUGES (2)

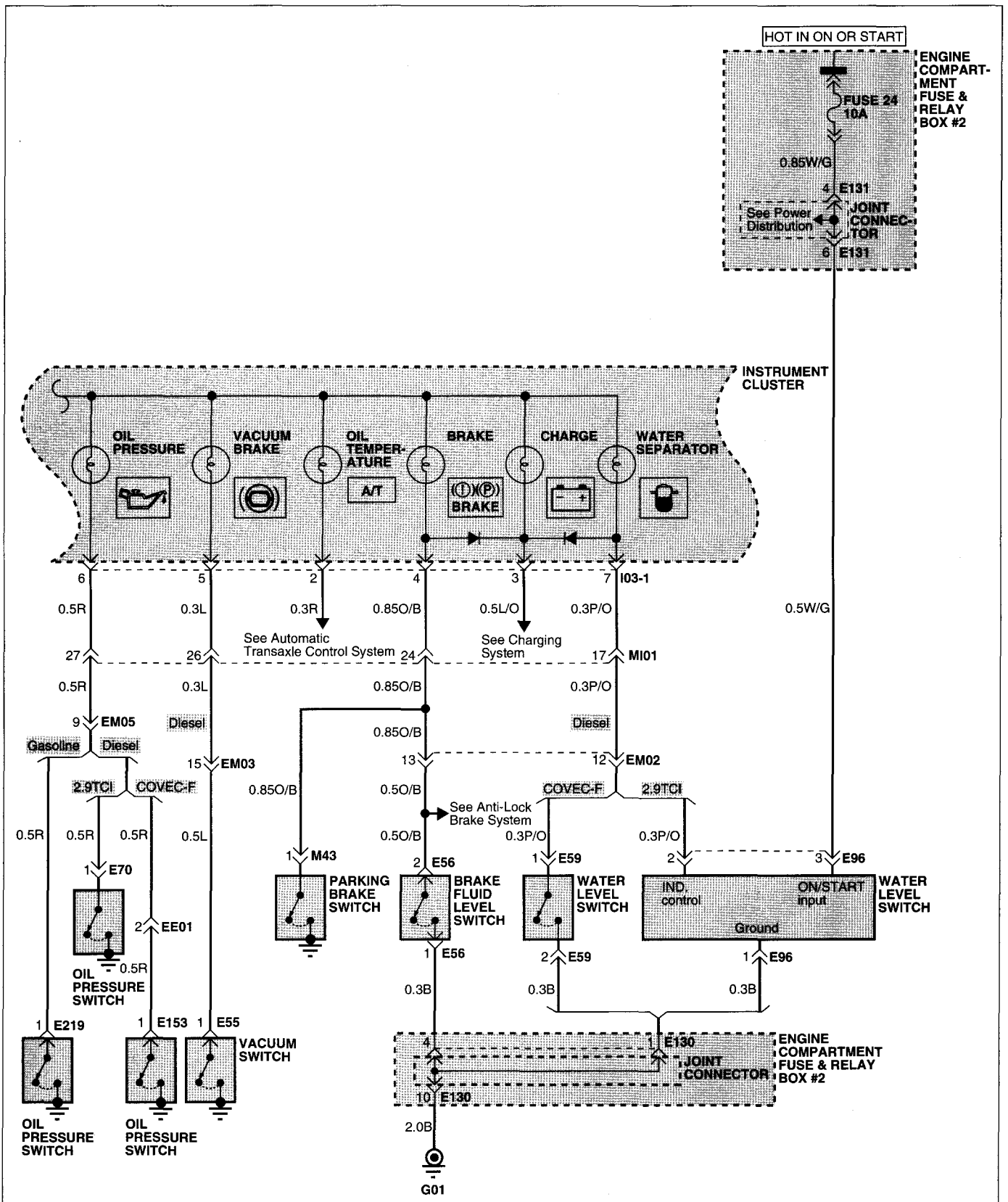

INDICATORS & GAUGES (3)

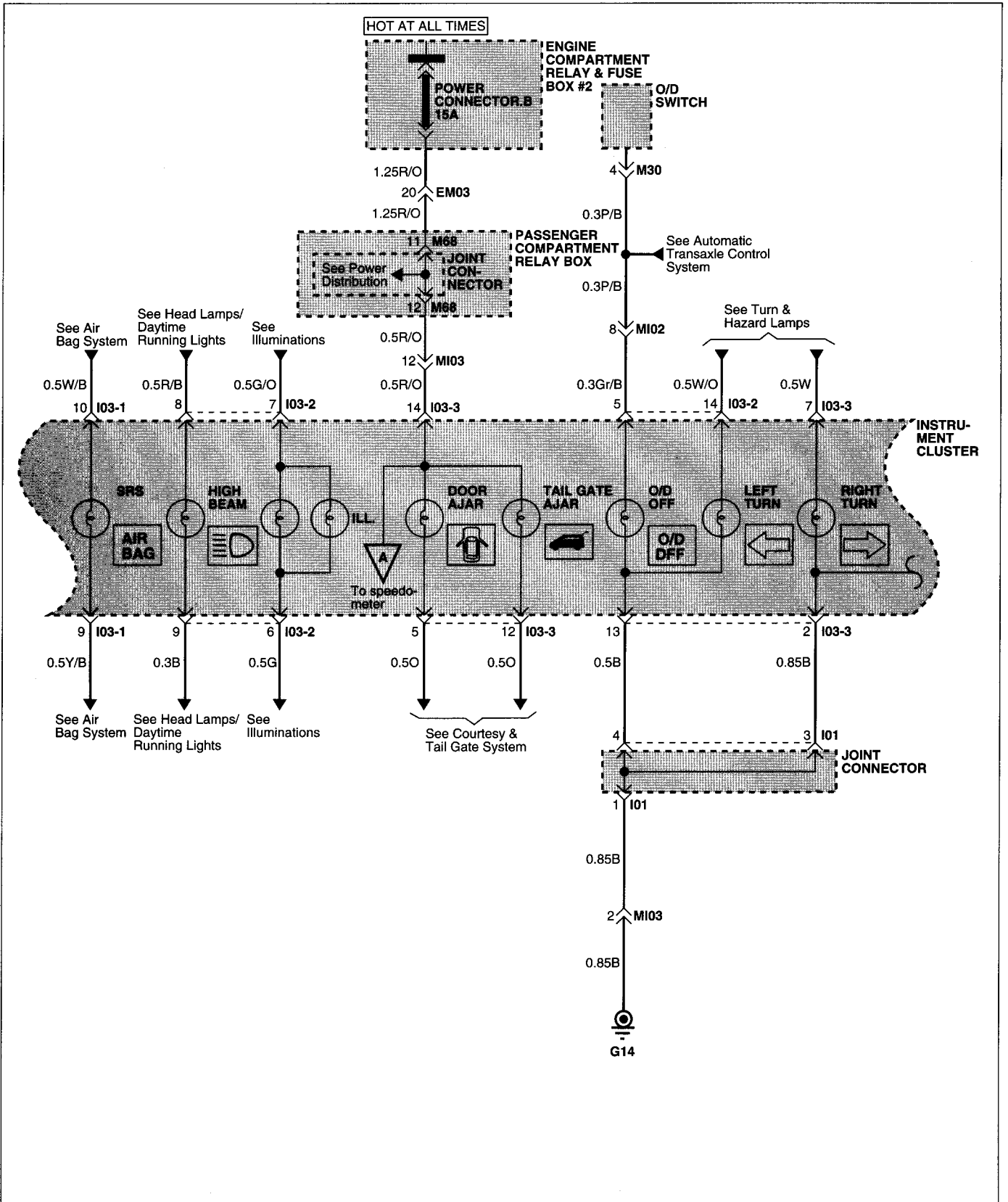

INDICATORS & GAUGES (4)

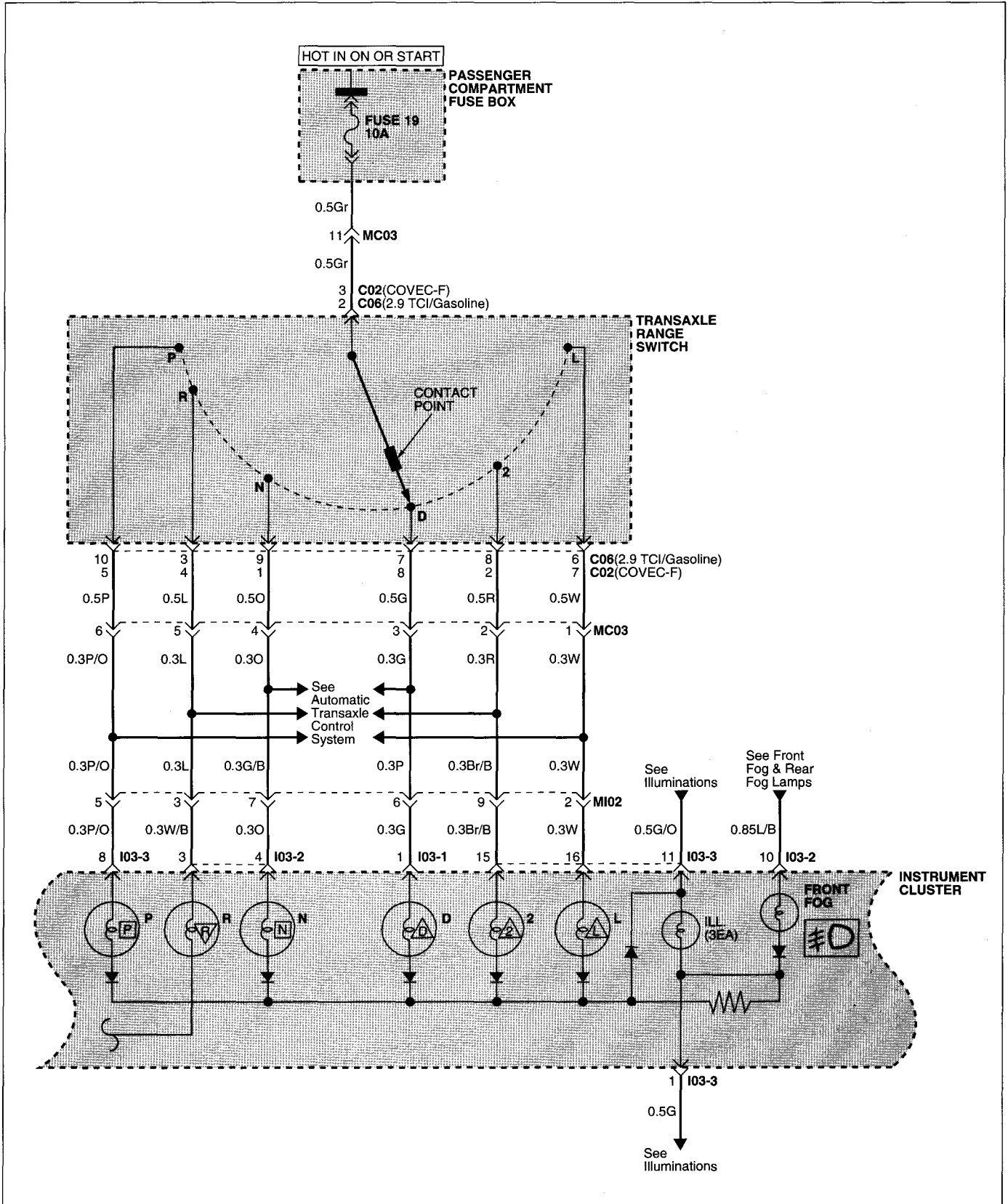

INDICATORS & GAUGES (5)

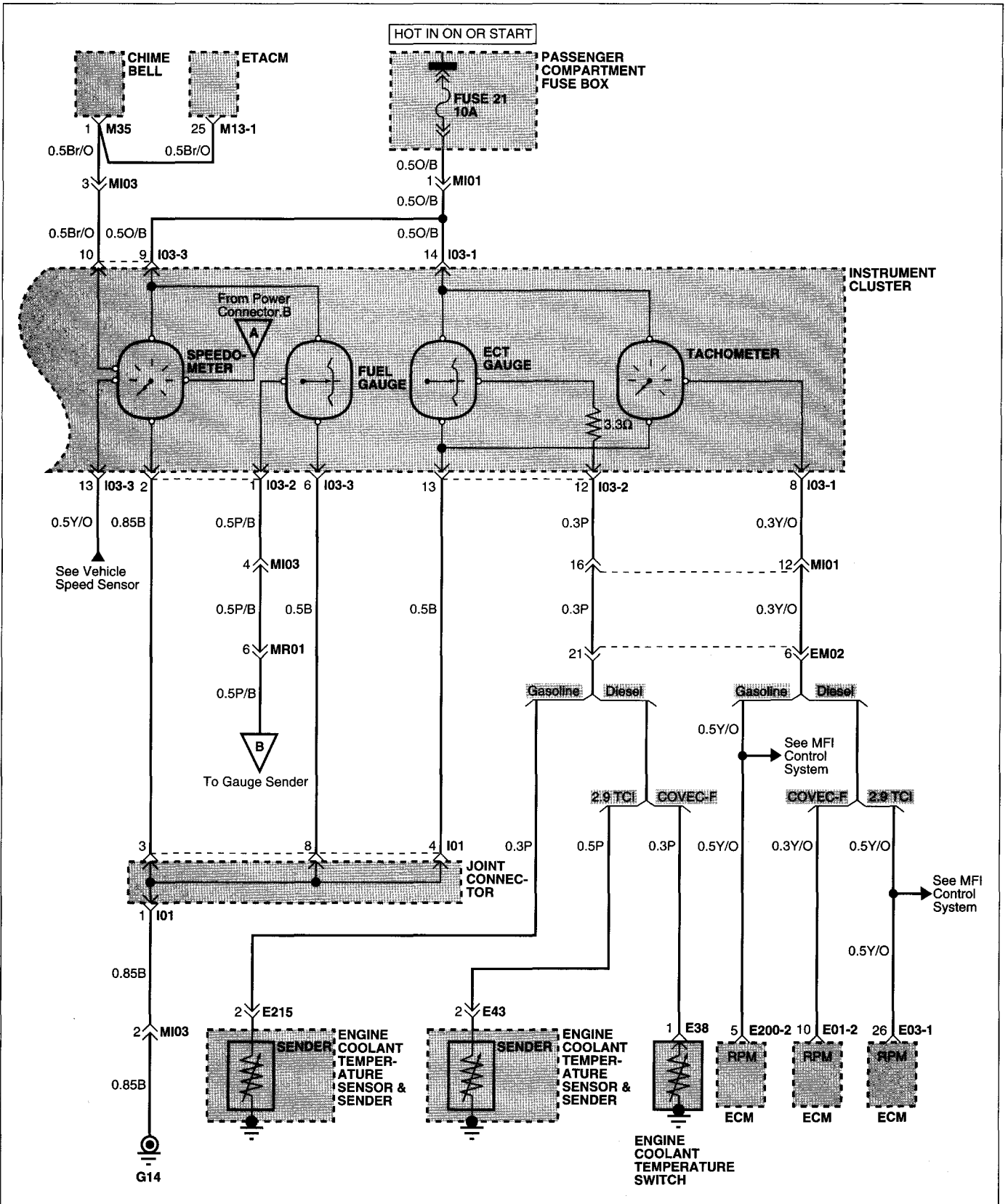

COMPONENT LOCATION INDEX

Components		Location reference - page
C02	Transaxle range switch (COVEC-F)	CL-21
C06	Transaxle range switch (Gasoline/2.9TCI)	CL-21
E01-2	ECM (COVEC-F)	CL- 8
E03-1	ECM (2.9TCI)	CL- 8
E38	Engine coolant temperature switch	CL-10
E43	Engine coolant temperature sensor & sender (2.9TCI)	CL-10
E55	Vacuum switch (Diesel)	CL-11
E56	Brake fluid level switch	CL-11
E59	Water level switch (COVEC-F)	CL-12
E70	Oil pressure switch (2.9TCI)	CL-13
E96	Water level switch (2.9TCI)	CL-14
E130	Joint connector	CL-14
E153	Oil pressure switch (COVEC-F)	CL-15
E200-1	ECM (Gasoline)	CL-16
E200-2	ECM (Gasoline)	CL-16
E215	Engine coolant temperature sensor & sender (Gasoline)	CL-16
E219	Oil pressure switch (Gasoline)	CL-17
I01	Joint connector	CL-20
I03-1	Instrument cluster	CL-20
I03-2	Instrument cluster	CL-20
I03-3	Instrument cluster	CL-20
M13-1	ETACM	CL- 2
M15	Multipurpose check connector	CL- 2
M30	O/D switch	CL- 4
M35	Chime bell	CL- 4
M43	Parking brake switch	CL- 4
M68	Joint connector	CL- 5
R05	Fuel tank (Gasoline)	CL-24
R06	Fuel tank (Diesel)	CL-24
Connectors		
EE01		CL-18
EM02		CL-19
EM03		CL-19
EM05		CL-19
MC03		CL- 6
MI01		CL- 6
MI02		CL- 6
MI03		CL- 6
MR01		CL- 7
Grounds		
G01		CL-29
G14		CL-29
G17		CL-30

Circuit Description

Gauges Operation

When the ignition switch is in the ON or START position, battery voltage is applied to the gauges (speedometer, tachometer, fuel gauge and engine coolant temperature gauge) from fuse 21.

Speedometer

The speedometer drive circuit receives pulses from the vehicle speed sensor (VSS). The pulse rate increases as the car accelerates. The frequency and duration of these input pulses are measured and displayed by the speedometer.

Tachometer

The tachometer displays engine speed in rpm. Voltage pulses are taken from the ignition system and sent to the tachometer. The tachometer responds to the frequency of the voltage pulses, which vary according to engine speed. The ECM process these pulses into a signal that causes the gauge needle to move.

Fuel Gauge

The pointer of the fuel gauge is moved by the magnetic fields of two coils. The coils are at right angles to each other. The magnetic field controlled by the fuel gauge sender causes the gauge needle to move. As the resistance in the sender varies, current through the gauge coils changes. When the fuel level is below the thermistor, the resistance of thermistor drops, providing a ground for the low fuel indicator bulb.

Engine Coolant Temperature Gauge

The pointer of the engine coolant temperature gauge is moved by the magnetic field of two coils. The coils are at right angles to each other. The magnetic fields controlled by the engine coolant temperature sender cause the gauge needle to move. As the resistance in the sender varies, current through the gauge coils changes.

Indicator Operation

When the ignition switch is in the ON or START position, battery voltage is applied to the indicator bulb from fuse 21.

Oil Pressure Indicator

When the oil pressure is low (oil pressure switch is closed), ground is provided to the oil pressure indicator bulb.

The oil pressure light comes on when the engine is not running and the ignition is in ON. In that case, the pressure switch remains closed and the indicator light stays on.

Low Fuel Indicator

The thermistor in the fuel gauge sender is located near the bottom of the tank. When the fuel level is below the thermistor, the resistance of thermistor lowers, providing a ground for the indicator.

Check ENGINE Indicator

The ground of the indicator lamp is controlled by the Engine Control Module. The control module will light the indicator when the ignition switch is turned ON (system check) or when the ECM detects engine problems.

MULTIMETER

E62DDA8F

MULTIMETER (1)

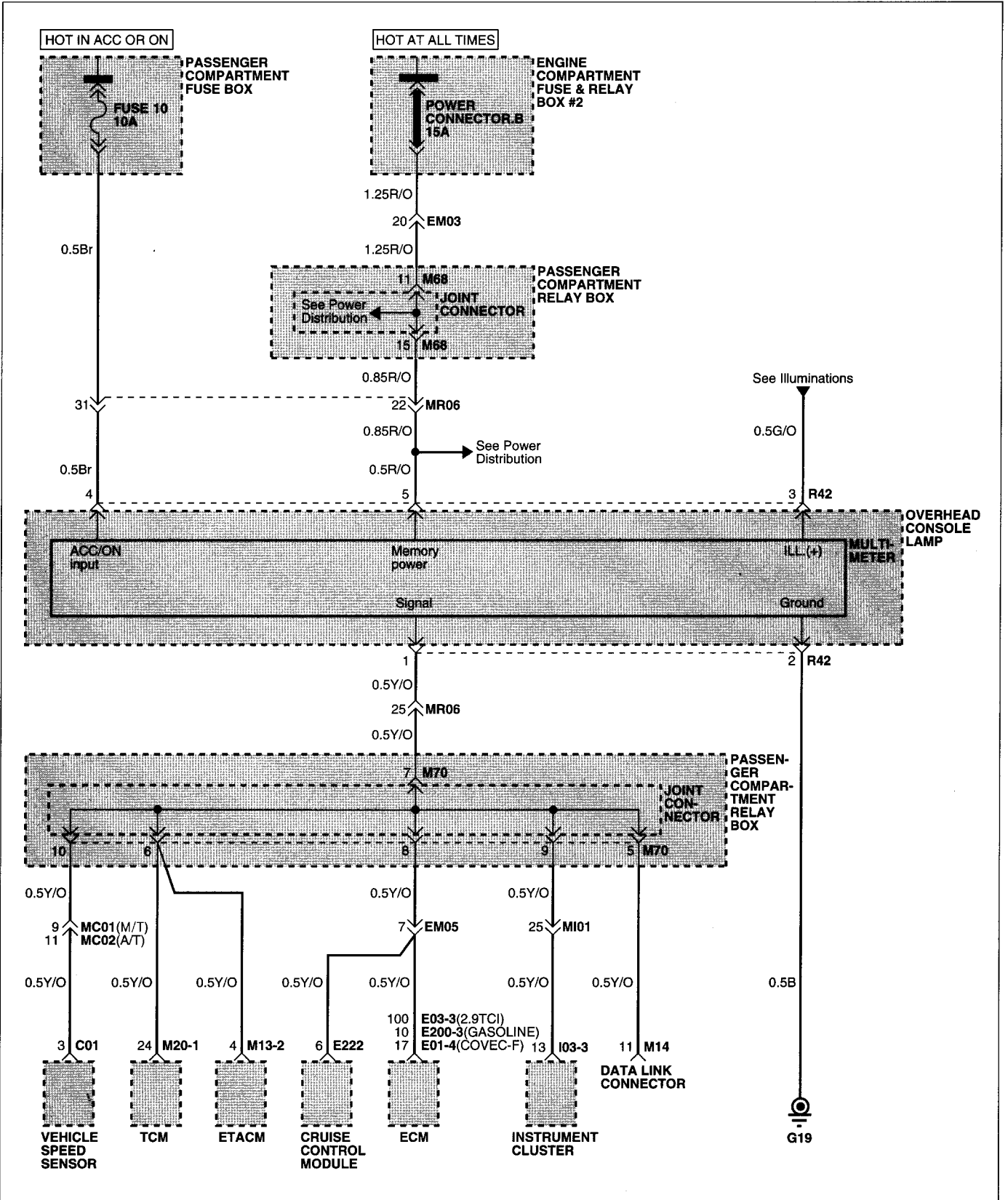

COMPONENT LOCATION INDEX

Components		Location reference - page
C01	Vehicle speed sensor	CL-21
E01-4	ECM (COVEC-F)	CL- 8
E03-3	ECM (2.9TCI)	CL- 8
E200-3	ECM (Gasoline)	CL-16
E222	Cruise control module	CL-17
I03-3	Instrument cluster	CL-20
M13-2	ETACM	CL- 2
M14	Data link connector	CL- 2
M20-1	TCM	CL- 3
M68	Joint connector	CL- 5
M70	Joint connector	CL- 5
R42	Overhead console lamp	CL-26
Connectors		
EM03		CL-19
EM05		CL-19
MC01		CL- 6
MC02		CL- 6
MI01		CL- 6
MR06		CL- 7
Grounds		
G19		CL-30

Circuit Description

Multimeter display compass, absolute altimeter, relative altimeter, barometer, vehicle velocity and digital clock. The display range of barometer is from 720 hpa to 1,045 hpa and that of absolute altimeter is from on to 3,000m. The input velocity of available display of compass is over 2.8km/h when the ignition switch is in ON, multimeter display vehicle velocity sensing the input speed signal.

Battery voltage is applied at all times to the multimeter in the overhead console lamp. With the ignition switch in ACC or ON, battery voltage is applied to the clock. The multimeter lights up and displays the time.

POWER DOOR LOCKS

EE83F77B

POWER DOOR LOCKS (1)

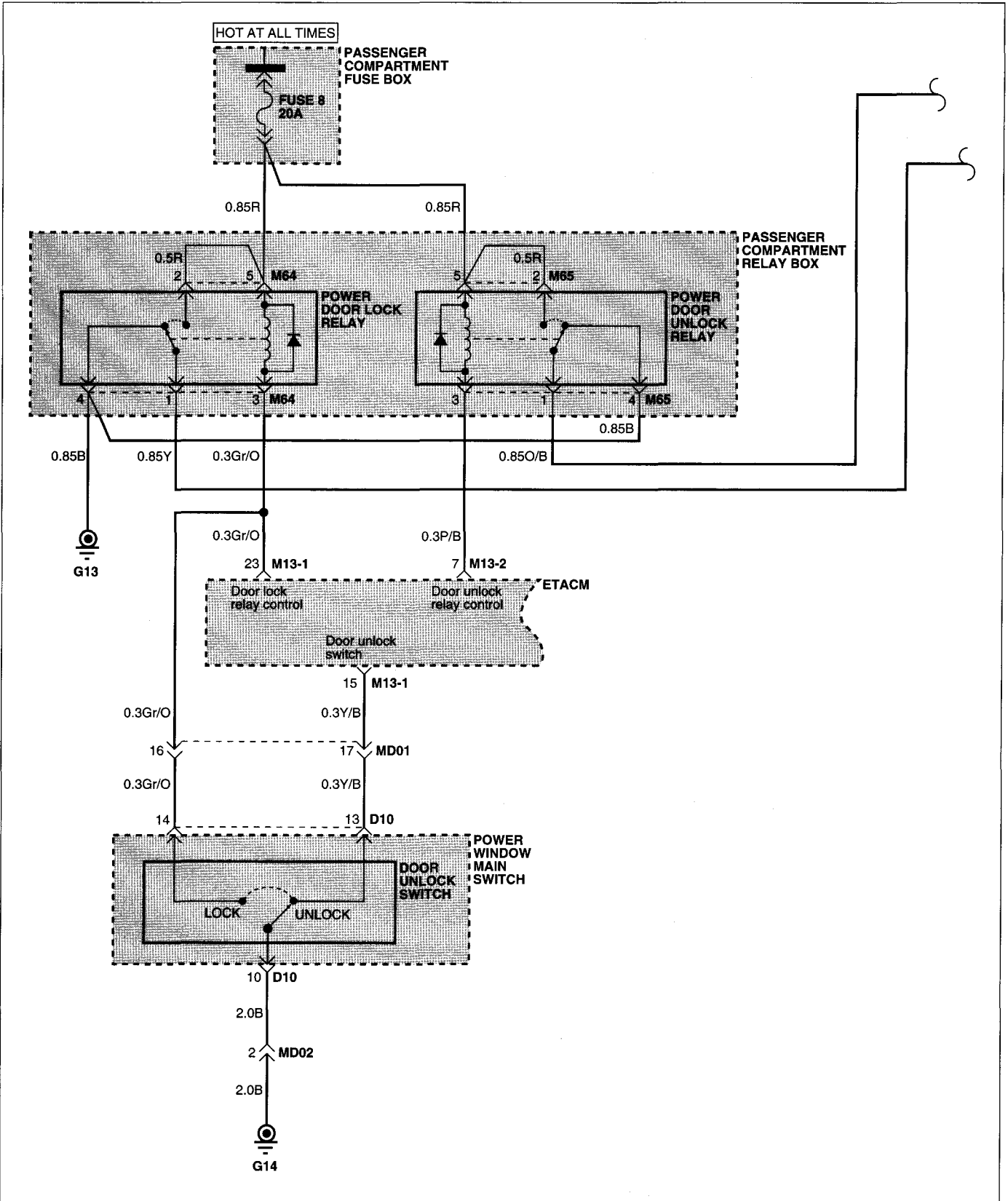

POWER DOOR LOCKS (2)

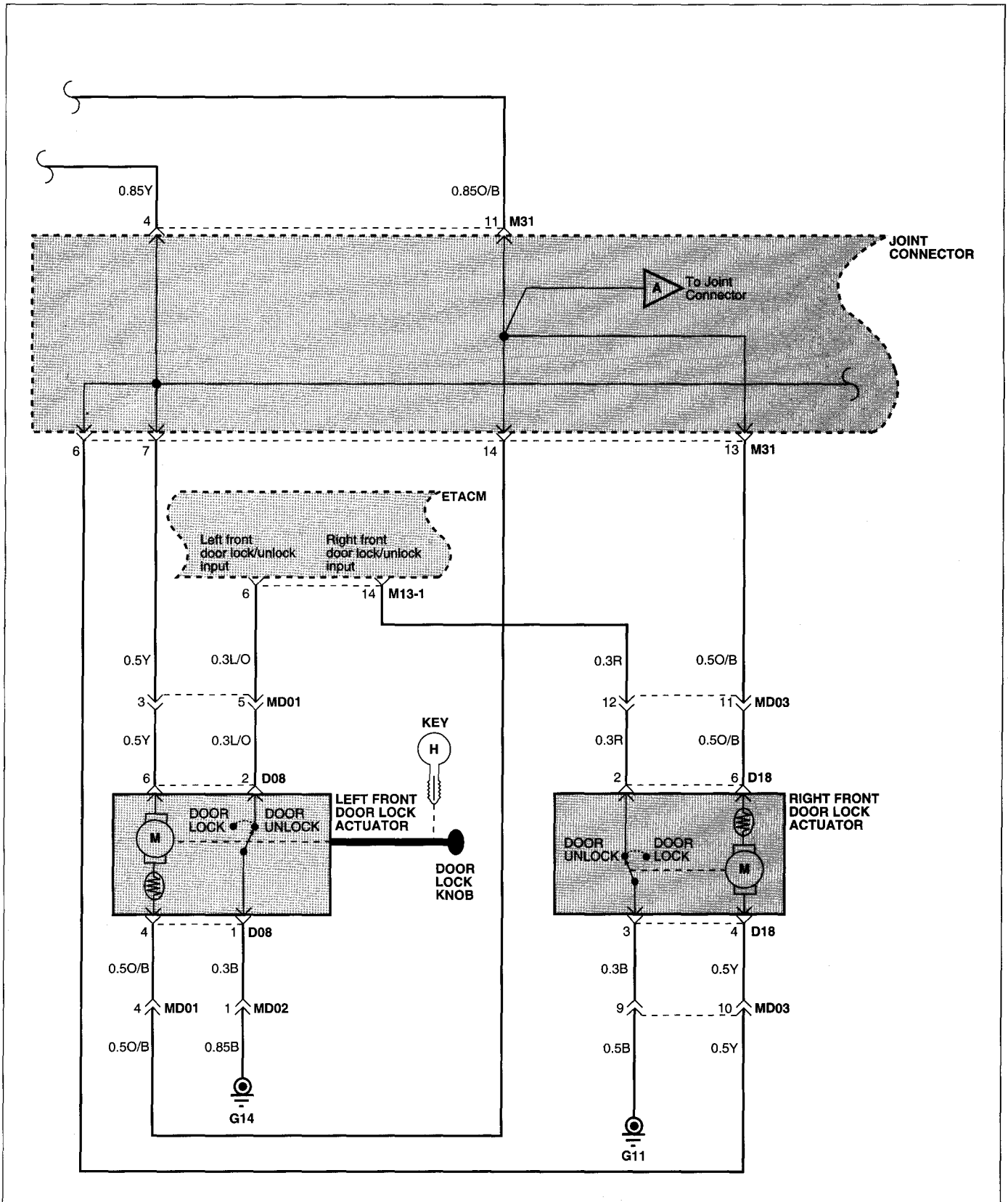

POWER DOOR LOCKS (3)

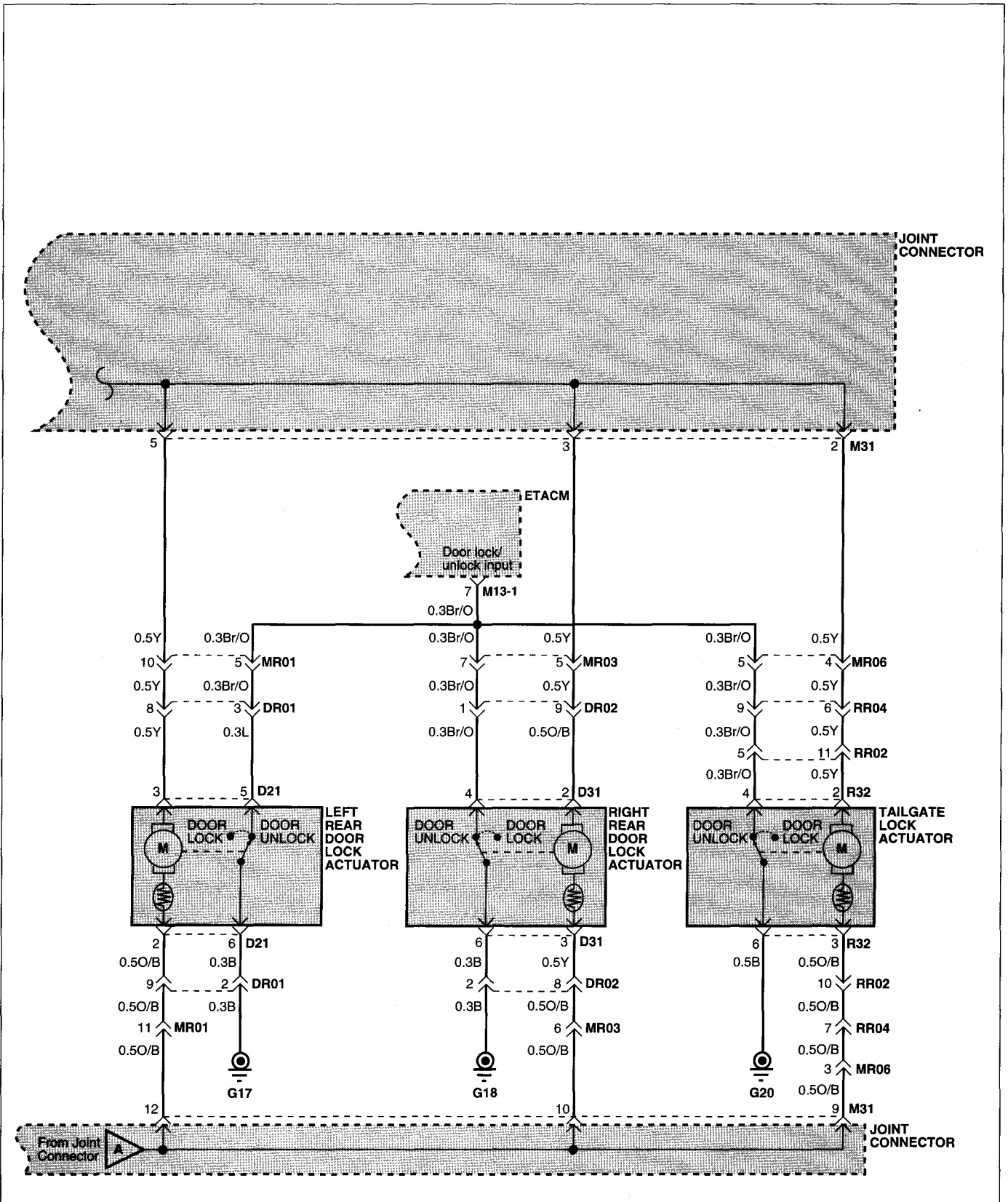

COMPONENT LOCATION INDEX

Components		Location reference - page
D08	Left front door lock actuator	CL-22
D10	Power window main switch	CL-22
D18	Right front door lock actuator	CL-22
D21	Left rear door lock actuator	CL-23
D31	Right rear door lock actuator	CL-23
M13-1	ETACM	CL- 2
M13-2	ETACM	CL- 2
M31	Joint connector	CL- 4
M64	Door lock relay	CL-12
M65	Door unlock relay	CL-12
R32	Tail gate lock actuator	CL-25
Connectors		
DR01		CL-23
DR02		CL-23
MD01		CL- 6
MD02		CL- 6
MD03		CL- 6
MR01		CL- 7
MR03		CL- 7
MR06		CL- 7
RR02		CL-26
RR04		CL-26
Grounds		
G11		CL-29
G13		CL-29
G14		CL-29
G17		CL-30
G18		CL-30
G20		CL-30

Circuit Description

Battery voltage is supplied to both the door lock and unlock relay at all times from fuse 8. There is a metal rod that links the left front door lock/unlock switch and the left front door lock actuator. When the left front door lock/unlock switch is pushed to lock, the metal rod then pushes the actuator switch in the left front door lock actuator to the lock position.

The ETACS control module receives the lock input signal and then supplies power to the left/ right rear doors, tail gate lock actuator and right front door lock actuator.

Each actuator is grounded through a limit switch in the appropriate door lock actuator. The ETACS control module will de-energize the relay coil when the limit switches in the door lock actuators move to the unlock position. The door lock works similarly when the left front door lock switch is pushed to unlock, except that the electrical current goes through each actuator in the opposite direction.

POWER OUTSIDE MIRRORS

EC214DB0

POWER OUTSIDE MIRRORS (1)

TABLE

MIRROR SELECT SWITCH	SELECTOR SWITCH POSITION	POSITION	Pin No.						
			7	8	1	4	5	3	6
LEFT	UP		○	○			○	○	
	DOWN		○	○			○	○	
	OFF		○	○			○	○	
RIGHT	UP				○	○			○
	DOWN				○	○			○
	OFF				○	○			○
LEFT	LEFT		○				○		○
	RIGHT		○				○		○
	OFF		○				○		○
RIGHT	LEFT				○				○
	RIGHT				○				○
	OFF				○				○

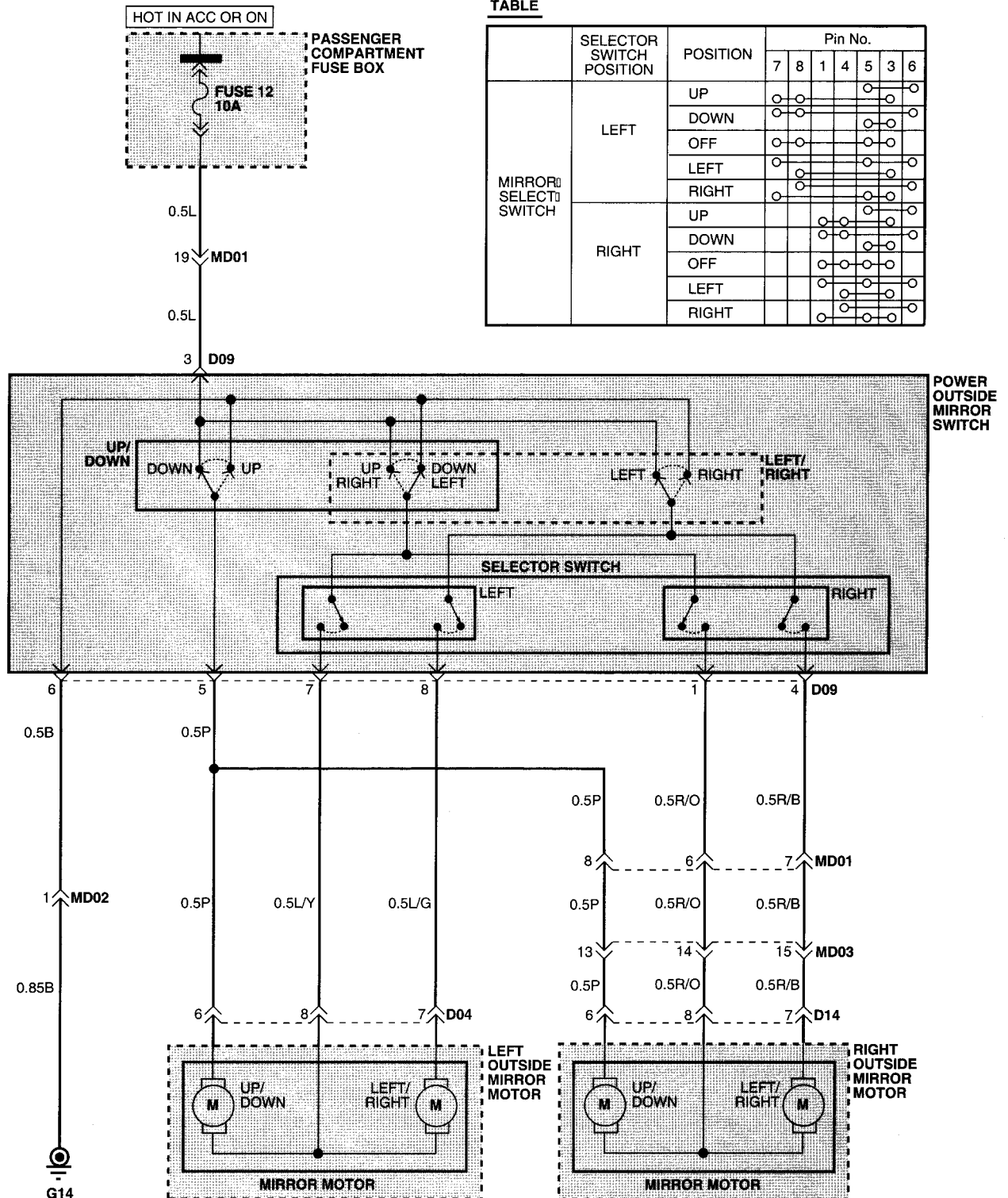

POWER OUTSIDE MIRROR SWITCH

LEFT OUTSIDE MIRROR MOTOR

RIGHT OUTSIDE MIRROR MOTOR

COMPONENT LOCATION INDEX

Components	Location reference - page
D04 Left outside mirror motor	CL-22
D09 Power outside mirror switch	CL-22
D14 Right outside mirror motor	CL-22
Connectors	
MD01	CL- 6
MD02	CL- 6
MD03	CL- 6
Grounds	
G14	CL-29

Circuit Description

The operation of the two mirrors is controlled by the power outside mirror switch. Each mirror has two reversible motors: one motor moves the mirror up and down; the other motor moves the mirror left and right. The mirror selector switch controls the direction of the battery voltage to the right or left outside mirror. With the ignition switch in ACC or ON, battery voltage is applied from fuse 12 to the power outside mirror switch. With the mirror selector switch in LEFT and the up/down switch in UP, battery voltage is applied to the up contacts of the up/down switch and to the left power mirror up/down motor.

Ground is provided to the up contacts of the up/down switch and the left power mirror up/down motor so the mirror goes up. In the DOWN position, battery voltage and ground are applied to the opposite terminals of the motor. The left/right switch works similarly to the up/down switch. With the mirror selector switch in the RIGHT position, battery voltage and ground are applied to the right power mirror motors.

REAR WINDOW & OUTSIDE MIRROR DEFOGGER SYSTEM

EB05B4C6

REAR WINDOW & OUTSIDE MIRROR DEFOGGER SYSTEM (1)

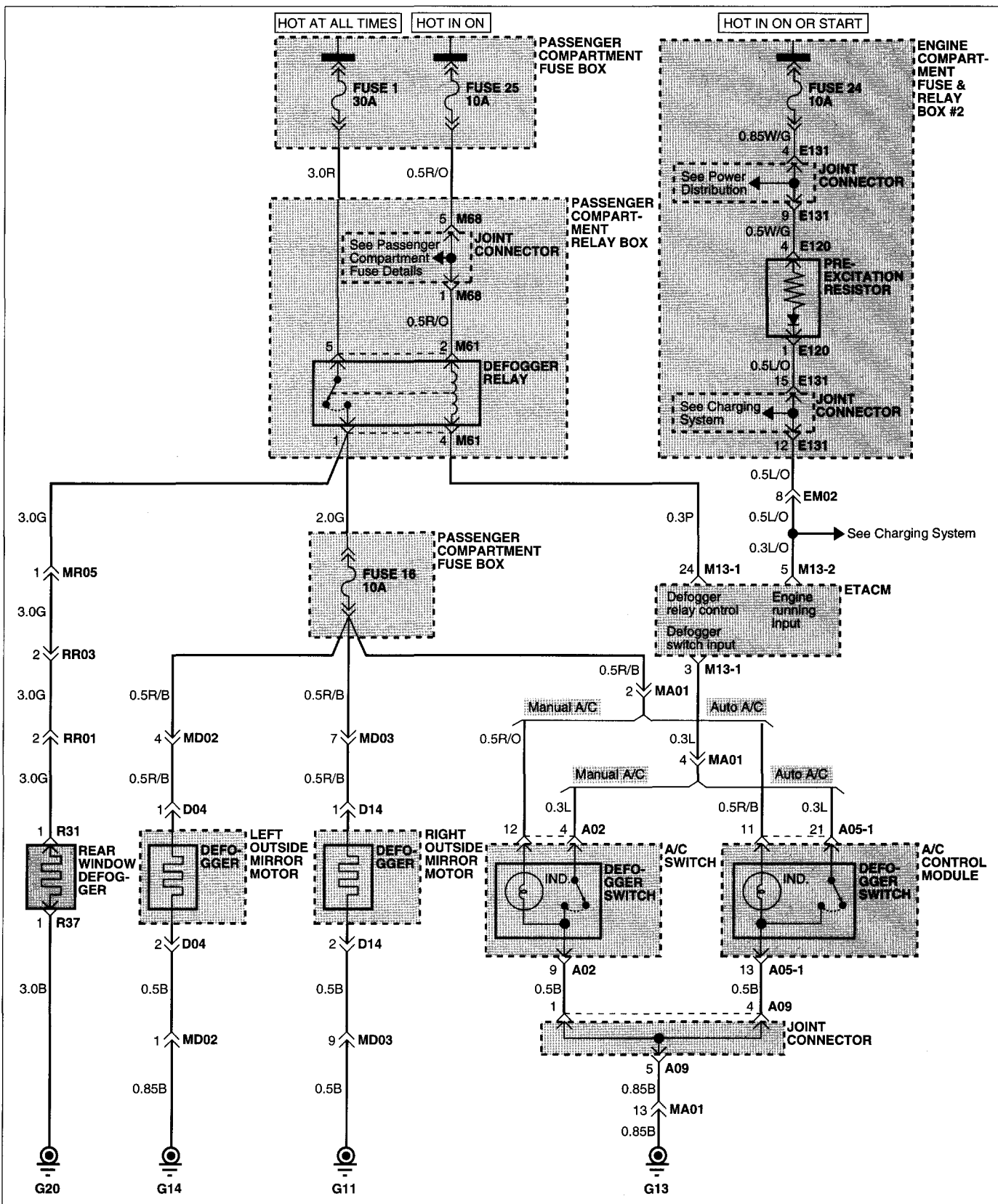

COMPONENT LOCATION INDEX

Components		Location reference - page
A02	A/C switch (Manual A/C)	CL-27
A05-1	A/C control module (Auto A/C)	CL-27
A09	Joint connector	CL-27
D04	Left outside mirror	CL-22
D14	Right outside mirror	CL-22
E120	Pre-excitation resistor	CL-14
E131	Joint connector	CL-14
M13-1	ETACM	CL- 2
M13-2	ETACM	CL- 2
M61	Defogger relay	CL- 5
M68	Joint connector	CL- 5
R31	Rear window defogger (+)	CL-25
R37	Rear window defogger (-)	CL-25
Connectors		
EM02		CL-19
MA01		CL- 6
MD02		CL- 6
MD03		CL- 6
MR05		CL- 7
RR01		CL-26
RR03		CL-26
Grounds		
G11		CL-29
G13		CL-29
G14		CL-29
G20		CL-30

Circuit Description

The ETACS control module controls the operation of the rear window defogger through the defogger relay coil control. Battery voltage applied to the coil and contacts of the defogger relay. When the rear window defogger switch is depressed (ON) and the engine is running, the defogger relay coil is energized through the ETACS control module for 20 minutes. Battery voltage is supplied to the rear window defogger through the defogger relay contacts.

ELECTRONIC CHROME MIRROR

E53AADD2

ELECTRONIC CHROME MIRROR (1)

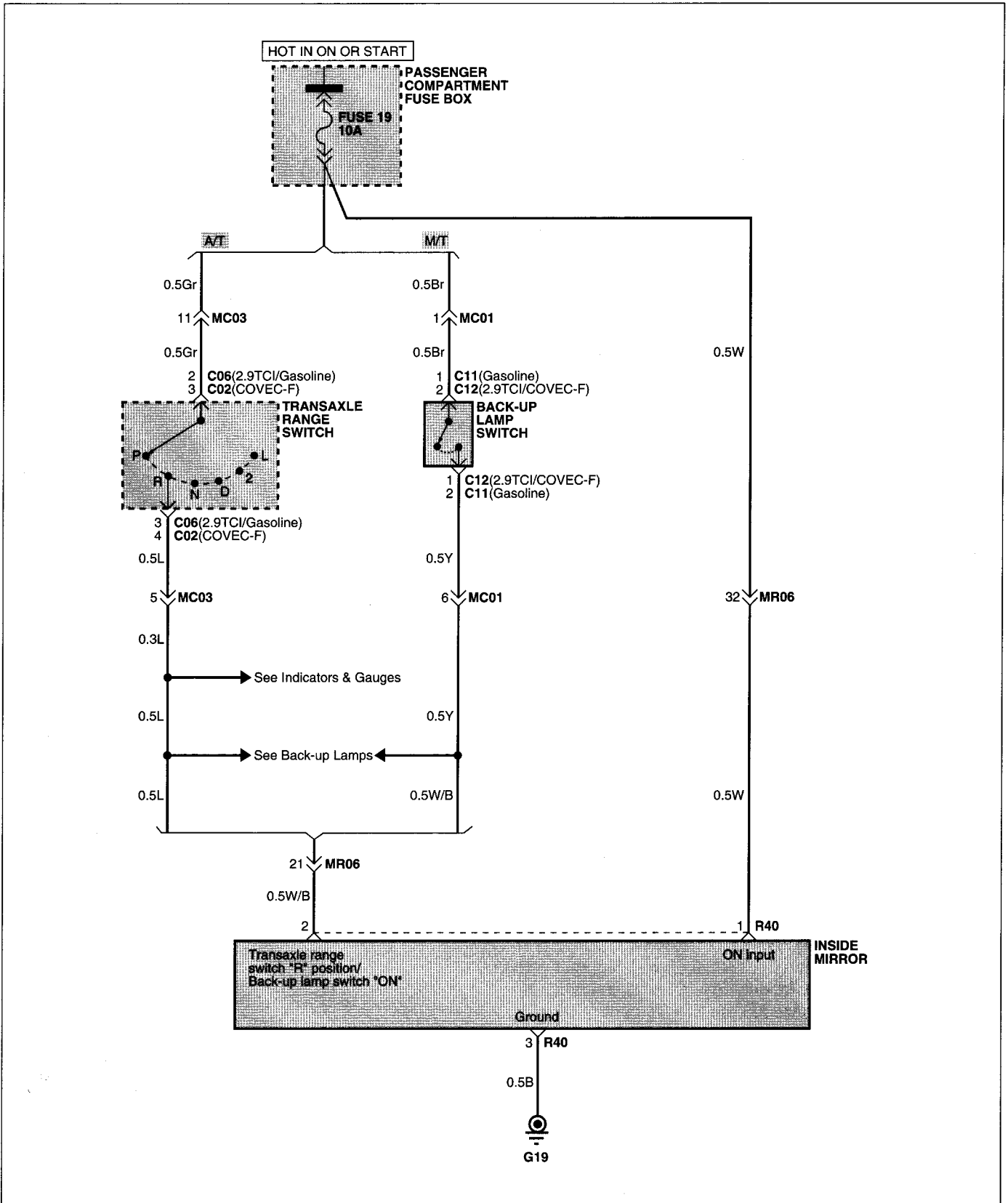

COMPONENT LOCATION INDEX

Components	Location reference - page
C02 Transaxle range switch (COVEC-F)	CL-21
C06 Transaxle range switch (Gasoline/2.9TCI)	CL-21
C12 Back-up lamp switch (2.9TCI/COVEC-F)	CL-21
M69 Joint connector	CL- 5
R40 Inside mirror	CL-25
 Connectors	
MC01	CL- 6
MC03	CL- 6
MR06	CL- 7
 Grounds	
G19	CL-30

Circuit Description

When the ignition switch is in ON or START and the transaxle range switch is in R position (automatic transaxle)/ back-up switch is in ON (manual transaxle), the electrical control mirror inactivates automatically to improve the visibility.

The electrical control mirror controls automatically the glare of headlight of cars behind you.

POWER SEAT

E4CF8BF7

POWER SEAT (1)

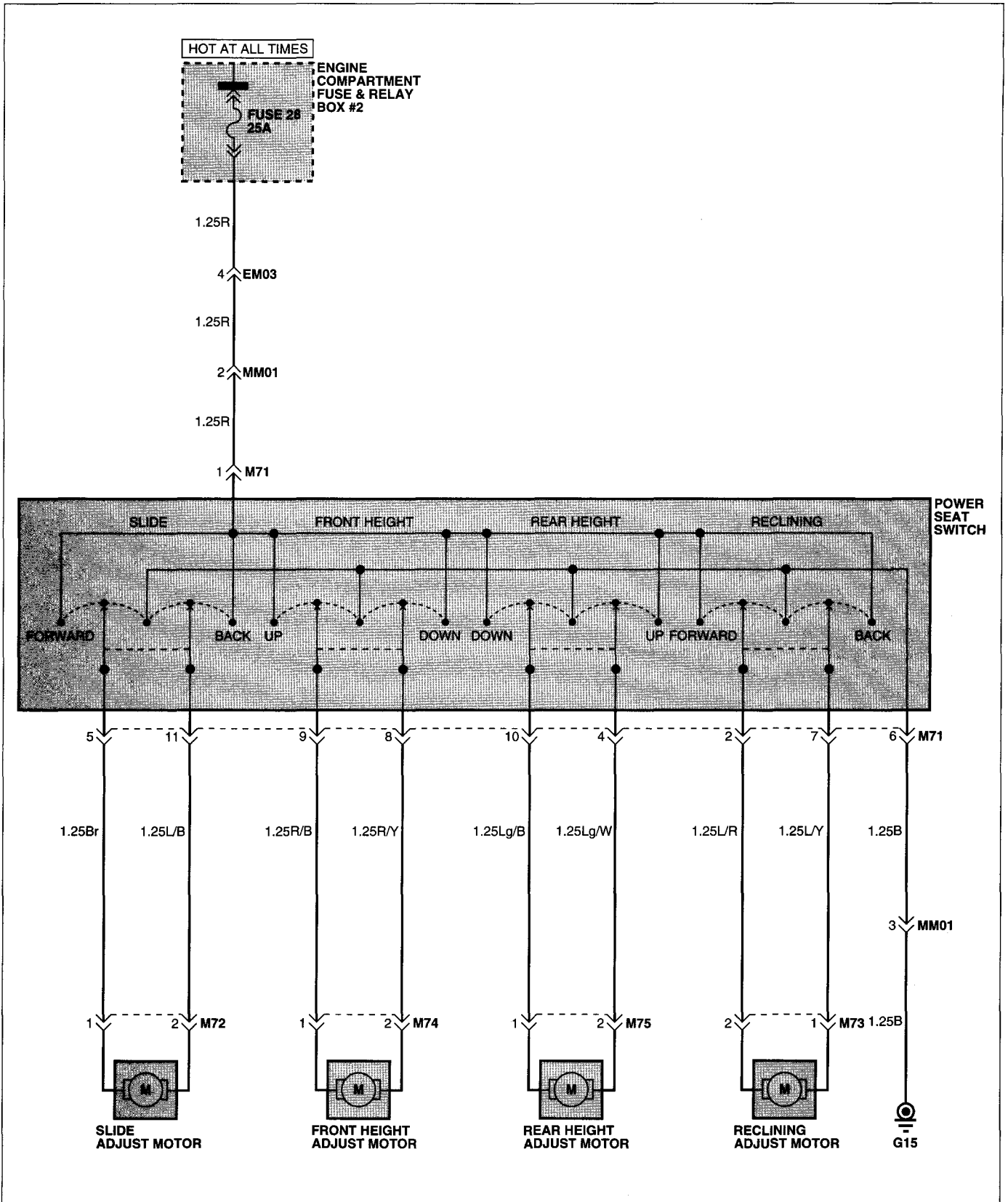

COMPONENT LOCATION INDEX

Components		Location reference - page
M71	Power seat switch	CL- 5
M72	Slide adjust motor	CL- 5
M73	Reclining adjust motor	CL- 5
M74	Front height adjust motor	CL- 5
M75	Rear height adjust motor	CL- 5
Connectors		
EM03		CL-19
MM01		CL- 7
Grounds		
G15		CL-30

SEAT WARMER

E73FCA32

SEAT WARMER (1)

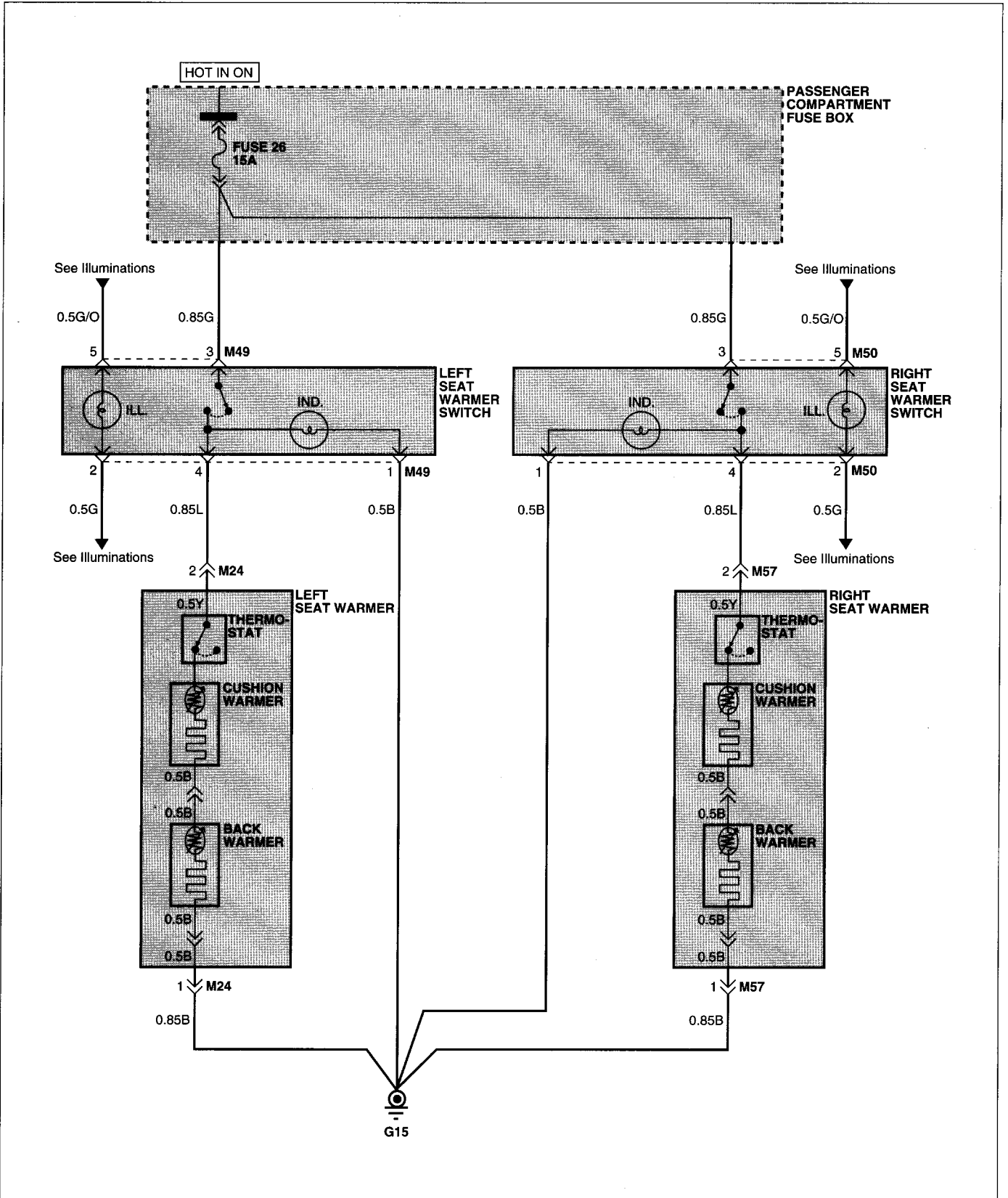

COMPONENT LOCATION INDEX

Components		Location reference - page
M24	Left seat warmer	CL- 3
M49	Left seat warmer switch	CL- 4
M50	Right seat warmer switch	CL- 4
M57	Right seat warmer	CL- 5
Grounds		
G15		CL-30

Circuit Description

Fuse 26 supplies battery voltage to the Left/Right front seat warmer when the ignition switch is "ON" and the Left/Right front seat warmer switches are pushed (ON). When each seat warmer switch is pushed, battery voltage supplied to the seat warmer and grounded through G15.

POWER WINDOWS

EE4129B7

POWER WINDOWS (1)

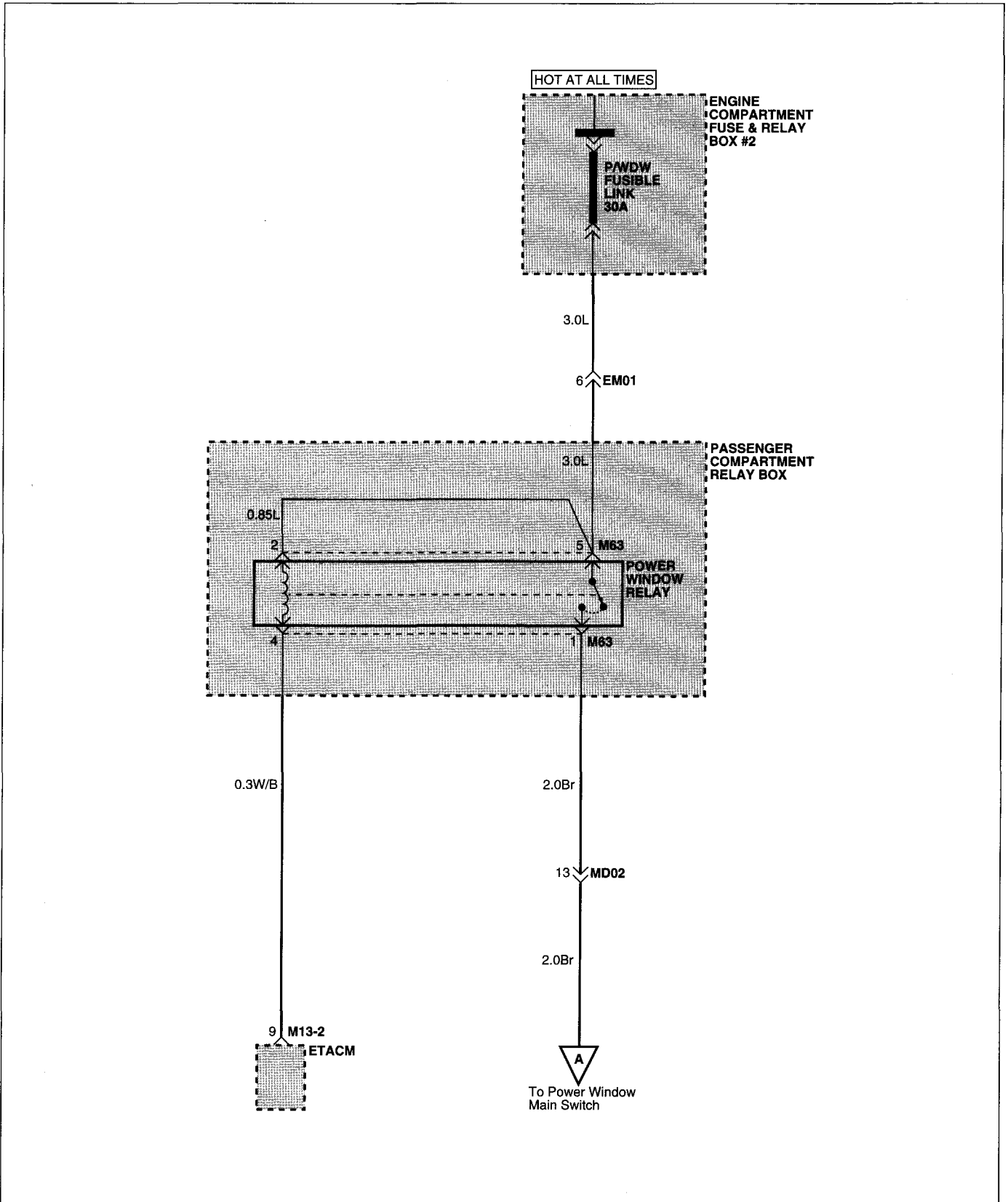

POWER WINDOWS (2)

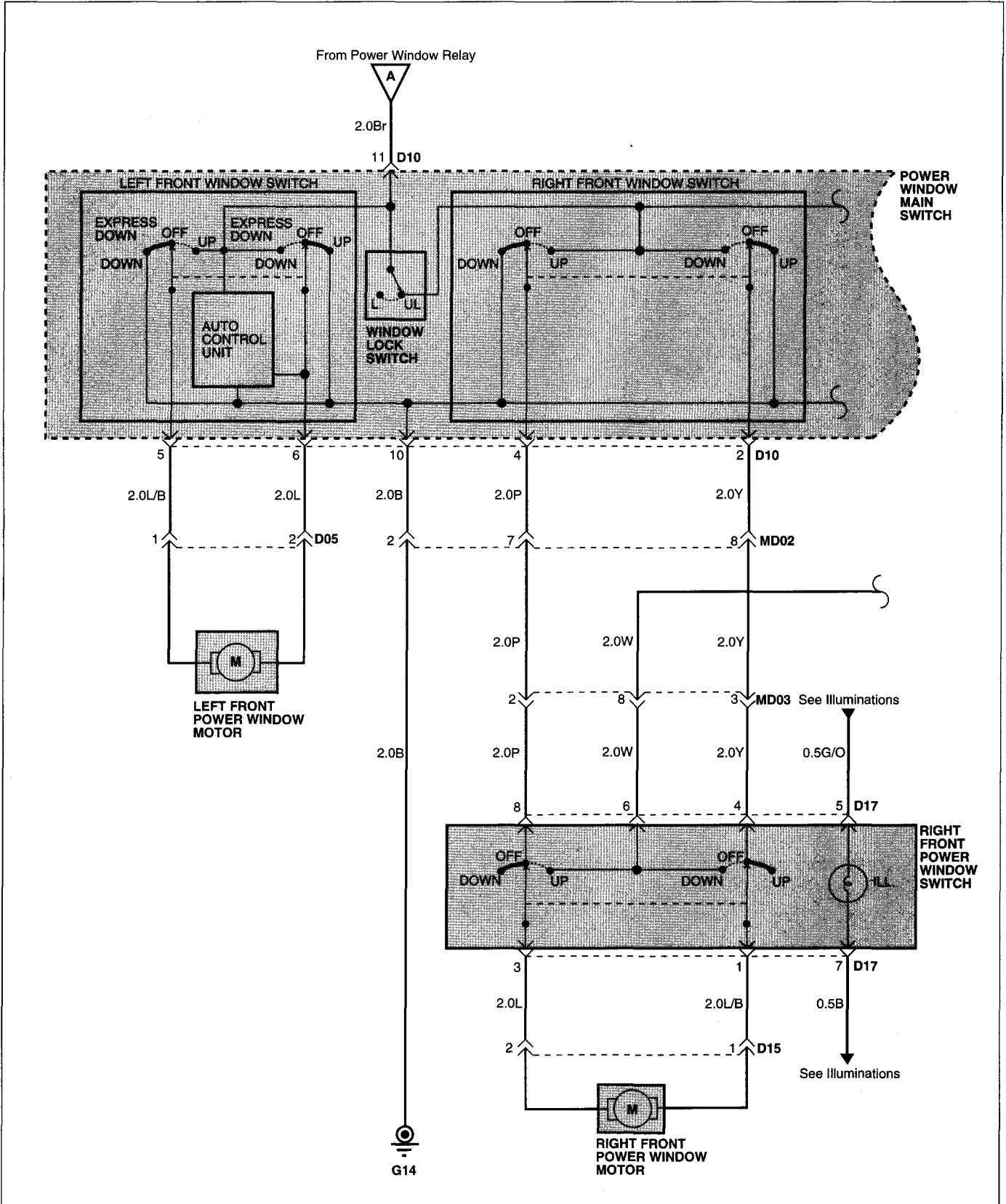

POWER WINDOWS (3)

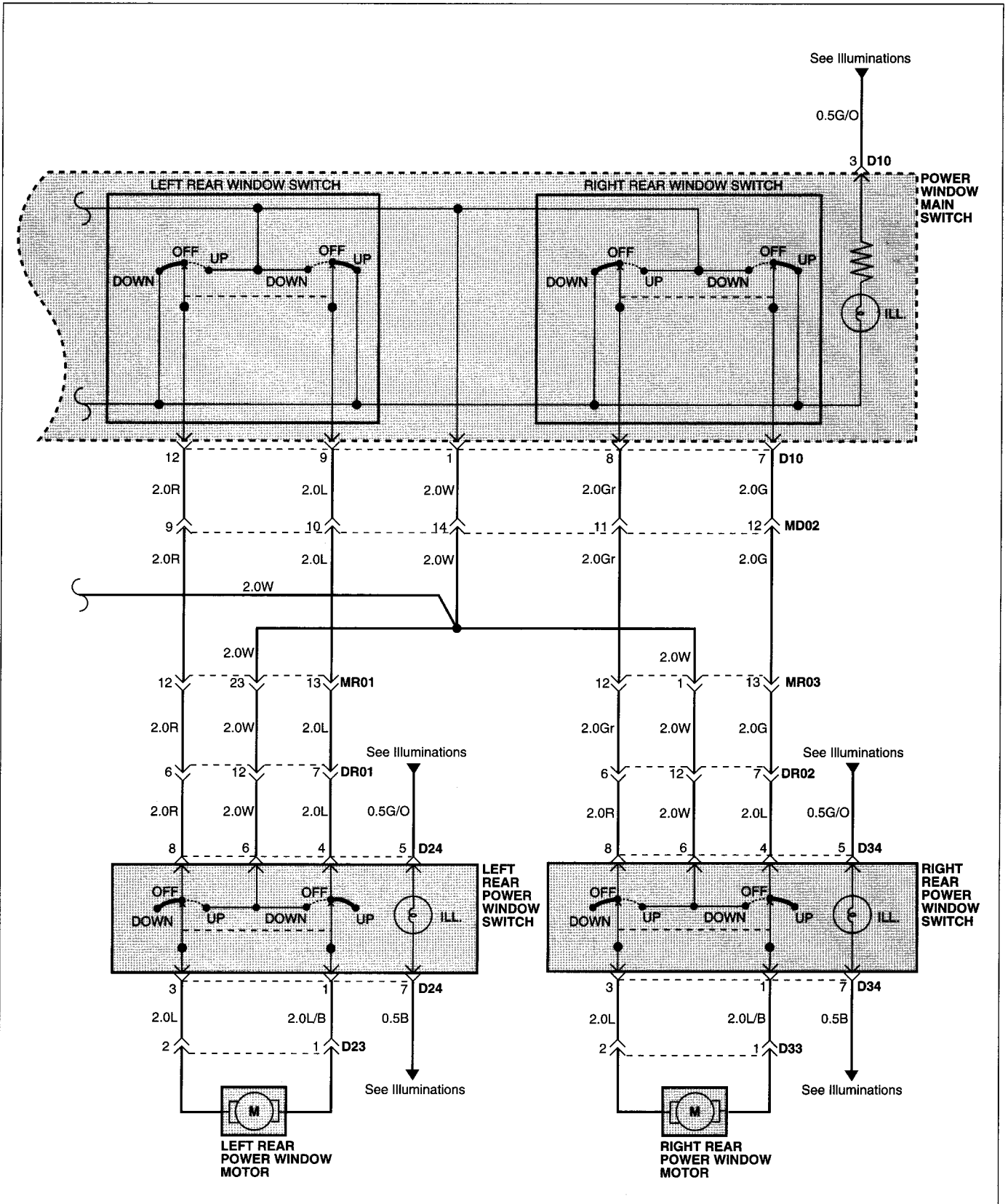

COMPONENT LOCATION INDEX

Components		Location reference - page
D05	Left front power window motor	CL-22
D10	Power window main switch	CL-22
D15	Right front power window motor	CL-22
D17	Right front power window switch	CL-22
D23	Left rear power window motor	CL-23
D24	Left rear power window switch	CL-23
D33	Right rear power window motor	CL-23
D34	Right rear power window switch	CL-23
M13-2	ETACM	CL- 2
M63	Power window relay	CL- 5
Connectors		
DR01		CL-23
DR02		CL-23
EM01		CL-19
MD02		CL- 6
MD03		CL- 6
MR01		CL- 7
MR03		CL- 7
Grounds		
G14		CL-29

Circuit Description

A permanent magnetic motor operates each of the power windows. Each motor raises or lowers the glass when voltage is supplied to it. The polarity of the supply voltage determines direction the motor turns.

The power window main switch controls all the power window motors. Each window switch controls only one of the power window motors. If the lock switch in the power outside mirror switch is depressed, the rear power windows and the right front power window cannot be controlled by their own window switches. However, they can still be controlled by the power window main switch.

Power Window Main Switch Operation

Battery voltage is applied at all times to both the coil and contact of the power window relay. The coil of the relay is energized when the ETACS control module supplies ground to the coil. Battery voltage is then supplied to the power window main switch through the closed relay contacts.

When any of the switches in the power window main switch are operated, battery voltage is applied to the appropriate power window motor. The power window motor is grounded through the opposite contact in the power window main switch. The power window motor runs to drive the window.

Window Switch Operation

When the power window relay coil is energized, battery voltage is also supplied to the appropriate passenger window switches as long as the lock switch in the power outside mirror switch is in unlock position. When the passenger window switch is operated, battery voltage is applied to one terminal of the power window motor and the other terminal is grounded through the opposite contact in the window switch and the main switch. The power window motor runs to drive the window.

SUNROOF

EBE5C4DF

SUNROOF (1)

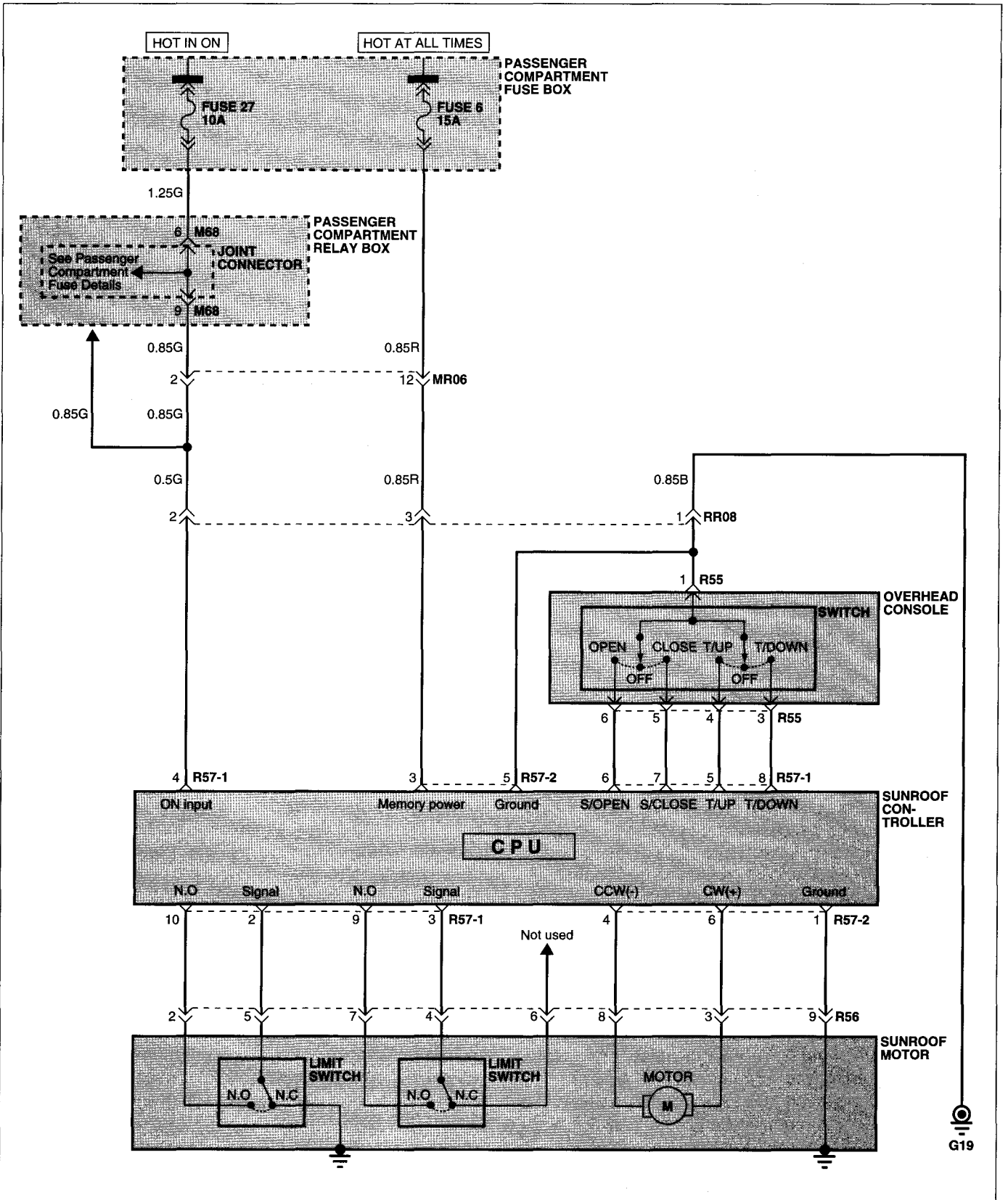

COMPONENT LOCATION INDEX

Components		Location reference - page
M68	Joint connector	CL- 5
R55	Overhead console	CL-26
R56	Sunroof motor	CL-26
R57-1	Sunroof controller	CL-26
R57-2	Sunroof controller	CL-26
Connectors		
MR06		CL- 7
RR08		CL-26
Grounds		
G19		CL-30

Circuit Description

Battery voltage is supplied at all times to open/tilt down and close/tilt up sunroof relay contacts. Open/tilt down relay and close/tilt up relay coils are also supplied battery voltage when the ignition switch is in ON.

When the ignition key is turned on and the open switch is depressed, the open/tilt down relay is energized.

Battery voltage is then supplied to the sunroof motor through the open/tilt down relay contacts. The motor is grounded through close/tilt up relay contact.

When the ignition key is turned on and the close switch is depressed, the close/tilt up relay is energized through roof open/close limit switch. When the sunroof is open, the roof open/close limit switch always contacts the open position. The tilt up and tilt down switch works similarly to the open switch.

The polarity of the voltage applied to the sunroof motor through sunroof relay contacts is changed according to the switch positions.

AUDIO SYSTEM

E0A55AB8

AUDIO SYSTEM (1)

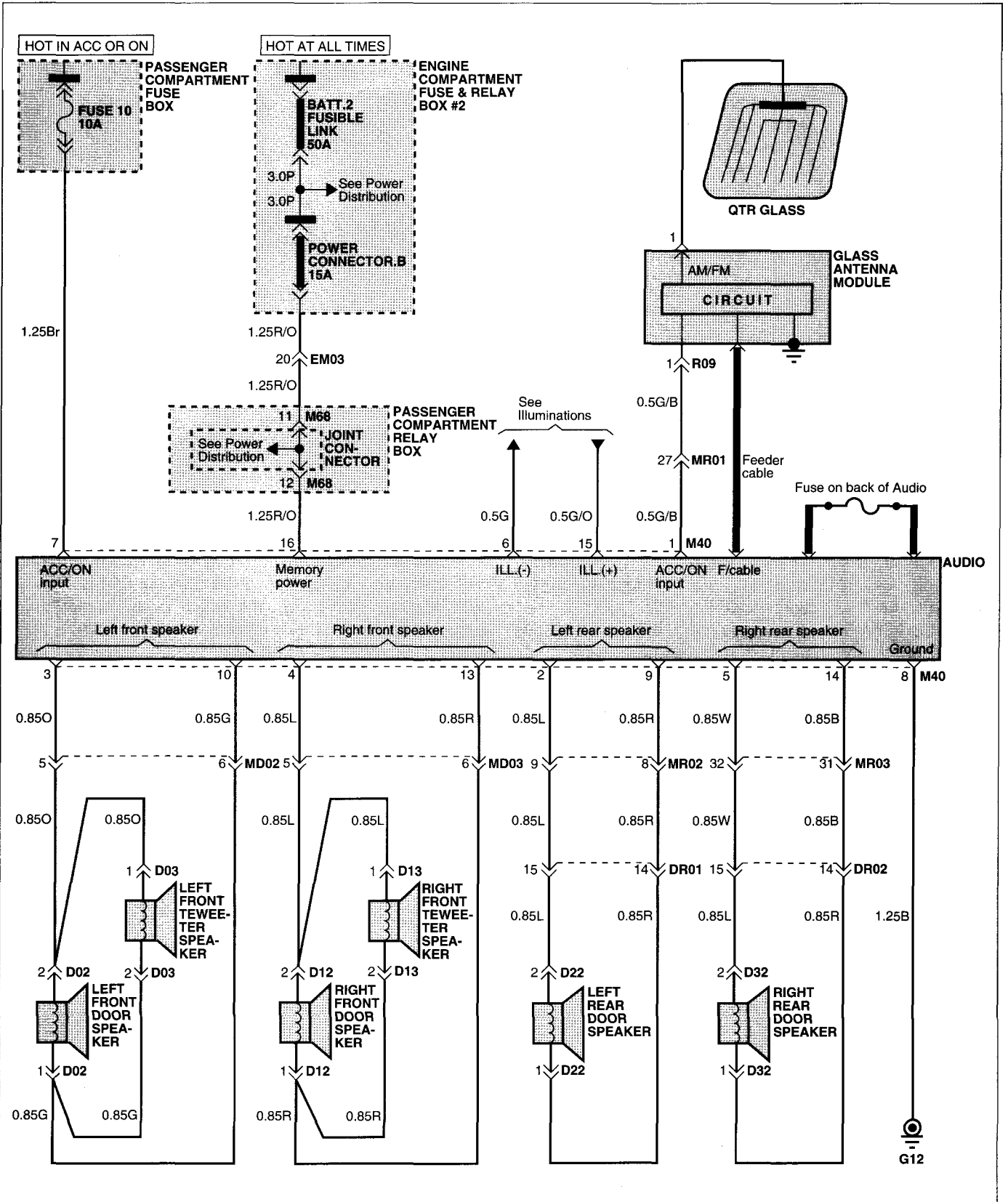

COMPONENT LOCATION INDEX

Components		Location reference - page
D02	Left front door speaker	CL-22
D03	Left front tweeter speaker	CL-22
D12	Right front door speaker	CL-22
D13	Right front tweeter speaker	CL-22
D22	Left rear door speaker	CL-23
D32	Right rear door speaker	CL-23
M40	Audio	CL- 4
M68	Joint connector	CL- 5
R09	Glass antenna module	CL-24
Connectors		
EM03		CL-19
DR01		CL-23
DR02		CL-23
MD02		CL- 6
MD03		CL- 6
MR01		CL- 7
MR02		CL- 7
MR03		CL- 7
Grounds		
G12		CL-29

Circuit Description

The audio unit receives battery voltage at all times from power connector B to maintain the memory function and antenna operation. Fuse 10 supplies battery voltage to the audio when the ignition switch is in ACC or ON for audio operation and the display. The audio is grounded at G12 and a noise filter is installed on the rear side of the audio case.

HORNS E8525EA3

HORNS (1)

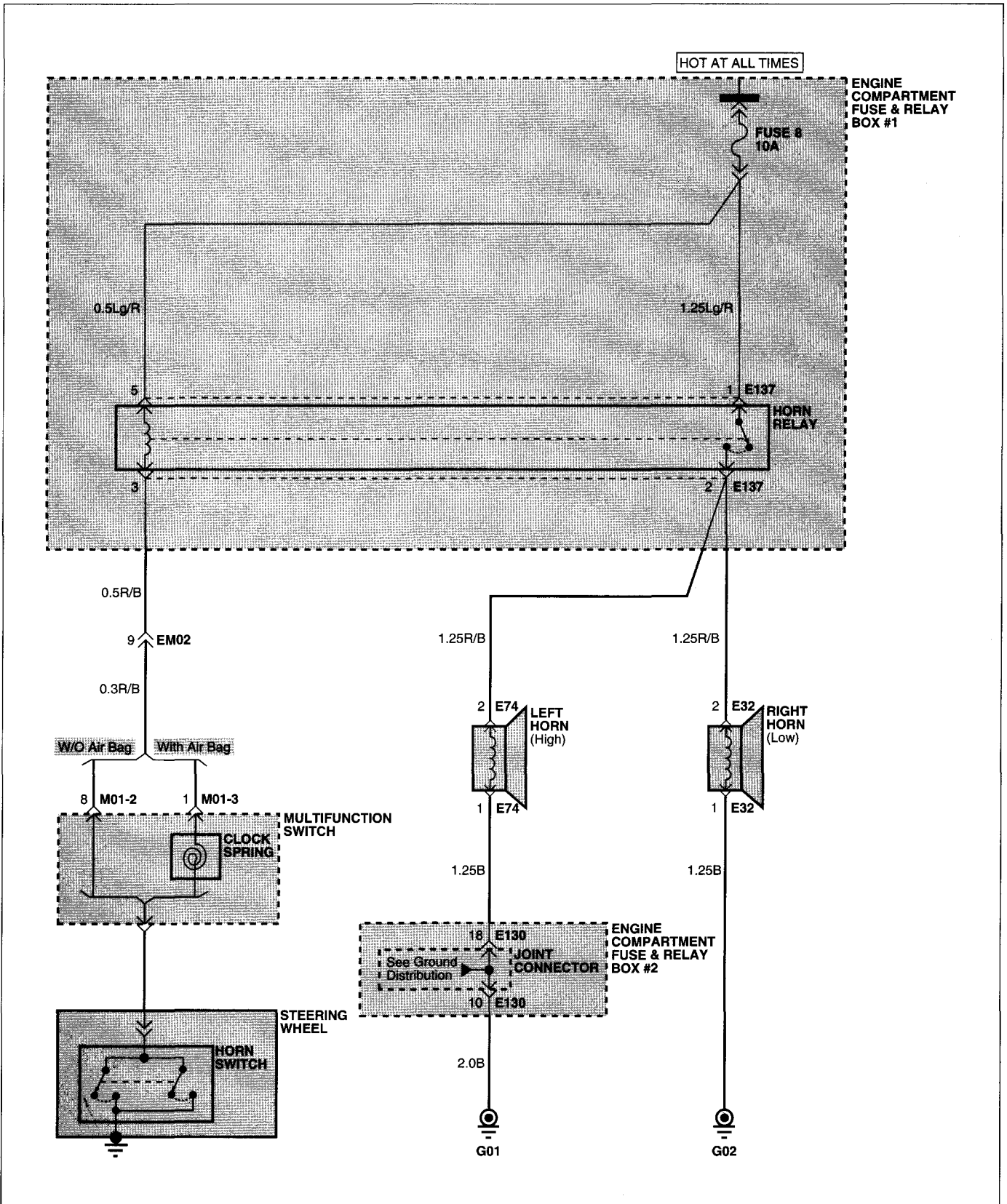

COMPONENT LOCATION INDEX

Components		Location reference - page
E32	Right horn	CL- 9
E74	Left horn	CL-13
E130	Joint connector	CL-14
E137	Horn relay	CL-14
M01-2	Multifunction switch	CL- 2
M01-3	Multifunction switch	CL- 2
Connectors		
EM02		CL-19
Grounds		
G01		CL-29
G02		CL-29

Circuit Description

Battery voltage is applied at all time to both the coil and the contacts of the horn relay through the horn fuse. With the horn switch depressed, ground is provided to the coil of the horn relay (coil energized) through the horn switch and then battery voltage is supplied to the horns through the closed relay contacts. The horns sound.

HEAD LAMPS E6AAF2B4

HEAD LAMPS (1)

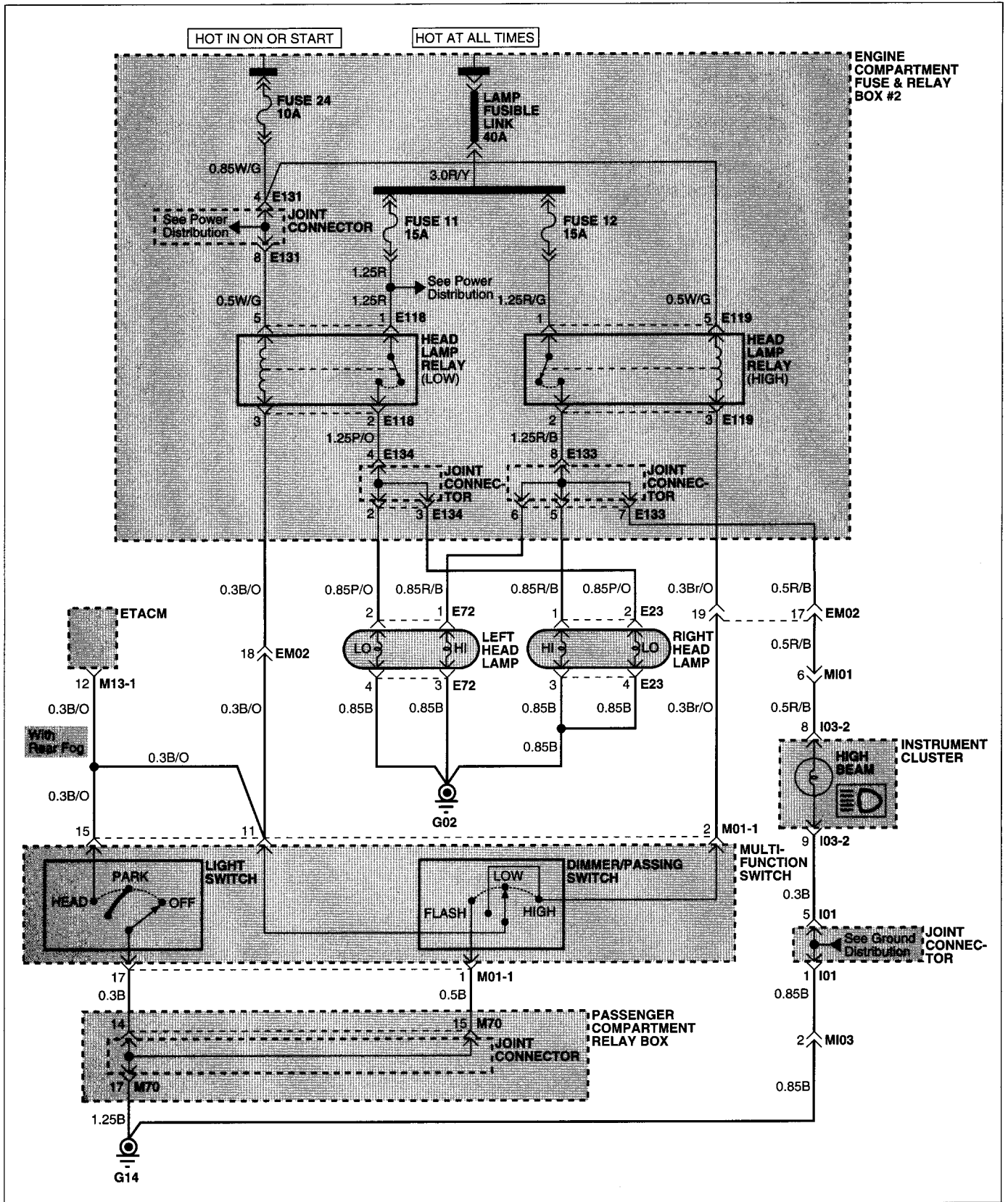

COMPONENT LOCATION INDEX

Components		Location reference - page
E23	Right head lamp	CL- 9
E72	Left head lamp	CL-13
E118	Head lamp relay (Low)	CL-14
E119	Head lamp relay (High)	CL-14
E131	Joint connector	CL-14
E133	Joint connector	CL-14
E134	Joint connector	CL-14
I01	Joint connector	CL-20
I03-2	Instrument cluster	CL-20
M01-1	Multifunction switch	CL- 2
M70	Joint connector	CL- 5
Connector		
EM02		CL-19
MI01		CL- 6
MI03		CL- 6
Grounds		
G02		CL-29
G14		CL-29

Circuit Description**Low Beam Operation**

With the ignition switch in ON, battery voltage is applied to the coil of the head lamp relays (low) from fuse 24. When the light switch is in HEAD, ground is provided to the coil of the low head lamp relay through the light switch. Battery voltage from fuse 11 is then provided to the low beam headlamps through the closed contacts of the head lamp relay (low). The low beam head lamps light.

High Beam Operation

With the ignition switch in ON, battery voltage is applied to the coil of head lamp relays (low/high) through fuse 24. When the light switch in HEAD, ground is provided to the coil of the head lamp relay (low) through the light switch. Battery voltage from fuse 11 is then provided to the low beam head lamps through the closed contacts of the head lamp relay (low). When the dimmer/passing switch is in HIGH, ground is provided to the high beam head lamps through the dimmer/passing switch and light switch. Ground is also provided to the high beam indicator in the instrument cluster.

Flash Operation

The flash feature works with the light switch in all positions (OFF, PARK or HEAD). When the light switch is in OFF or PARK and the dimmer/passing switch is in FLASH, ground is provided to the head lamp relays (high/low) through the dimmer/passing switch. Battery voltage is applied to the high/low beam head lamps and the beam indicator. When the light switch is in HEAD and the dimmer/passing switch is in FLASH, ground is provided to the head lamp relay (high/low) through the dimmer/passing switch and light switch. Battery voltage is applied to the high/low beam head lamps and the beam indicator. The high beams and the high beam indicator light as long as the dimmer/passing switch is held in the FLASH position.

DAYTIME RUNNING LIGHTS

E7940A2D

DAYTIME RUNNING LIGHTS (1)

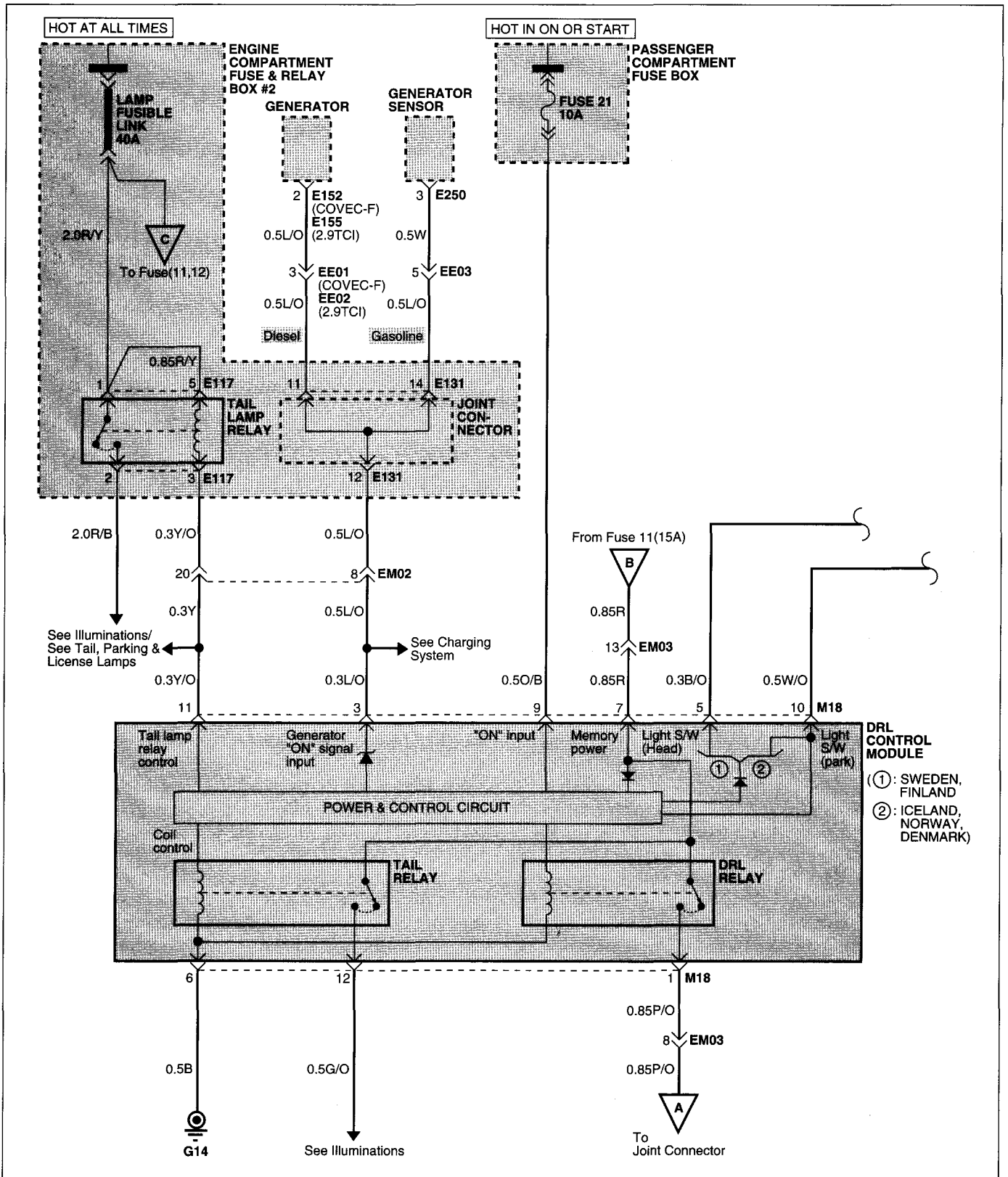

DAYTIME RUNNING LIGHTS (2)

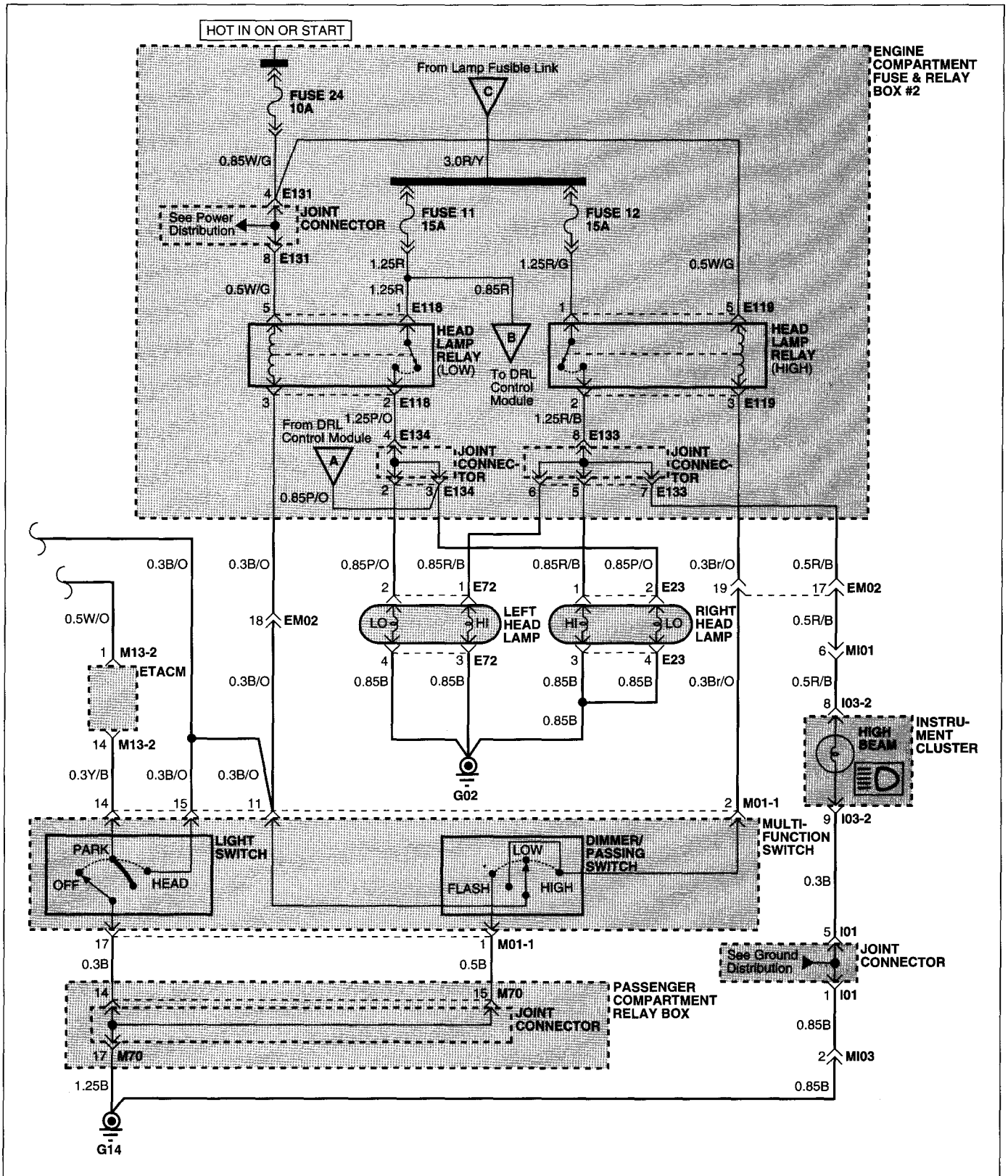

COMPONENT LOCATION INDEX

Components		Location reference - page
E23	Right head lamp	CL- 9
E72	Left head lamp	CL-13
E117	Tail lamp relay	CL-14
E118	Head lamp relay (Low)	CL-14
E119	Head lamp relay (High)	CL-14
E131	Joint connector	CL-14
E133	Joint connector	CL-14
E134	Joint connector	CL-14
E152	Generator (L,S) (COVEC-F)	CL-15
E155	Generator (L,S) (2.9TCl)	CL-15
E250	Generator sensor (Gasoline)	CL-18
I01	Joint connector	CL-20
I03-2	Instrument cluster	CL-20
M01-1	Multifunction switch	CL- 2
M13-2	ETACM	CL- 2
M18	DRL control module	CL- 3
M70	Joint connector	CL- 5
Connectors		
EE01		CL-18
EE02		CL-18
EE03		CL-18
EM02		CL-19
EM03		CL-19
MI01		CL- 6
MI03		CL- 6
Grounds		
G02		CL-29
G14		CL-29

Circuit Description

For the visibility and safety of drivers, the daytime running lights will turn on automatically when the engine is running. Under this condition, the head lamps will illuminate with a minimal amount of load on the charging system. As the DRL control module detects the generator running signals (engine running signal), the DRL control module controls the operation of the low beam head lamps through DRL relay coil control. Battery voltage from fusible link is then provided to the low beam head lamps through the DRL relay contact.

In addition to the DRL relay control, the DRL control module controls the tail relay (built in to the DRL control module) coil. Battery voltage is applied to the closed contact of the tail lamp relay and the interior illumination lamps turn on. When the DRL module detects the engine running OFF signal, the DRL control module turns the lights off. When the DRL module detects the light switch in ON (PARK or HEAD) signal, the DRL control module stops its functions.

HEAD LAMP LEVELING DEVICE

EE42CAF6

HEAD LAMP LEVELING DEVICE (1)

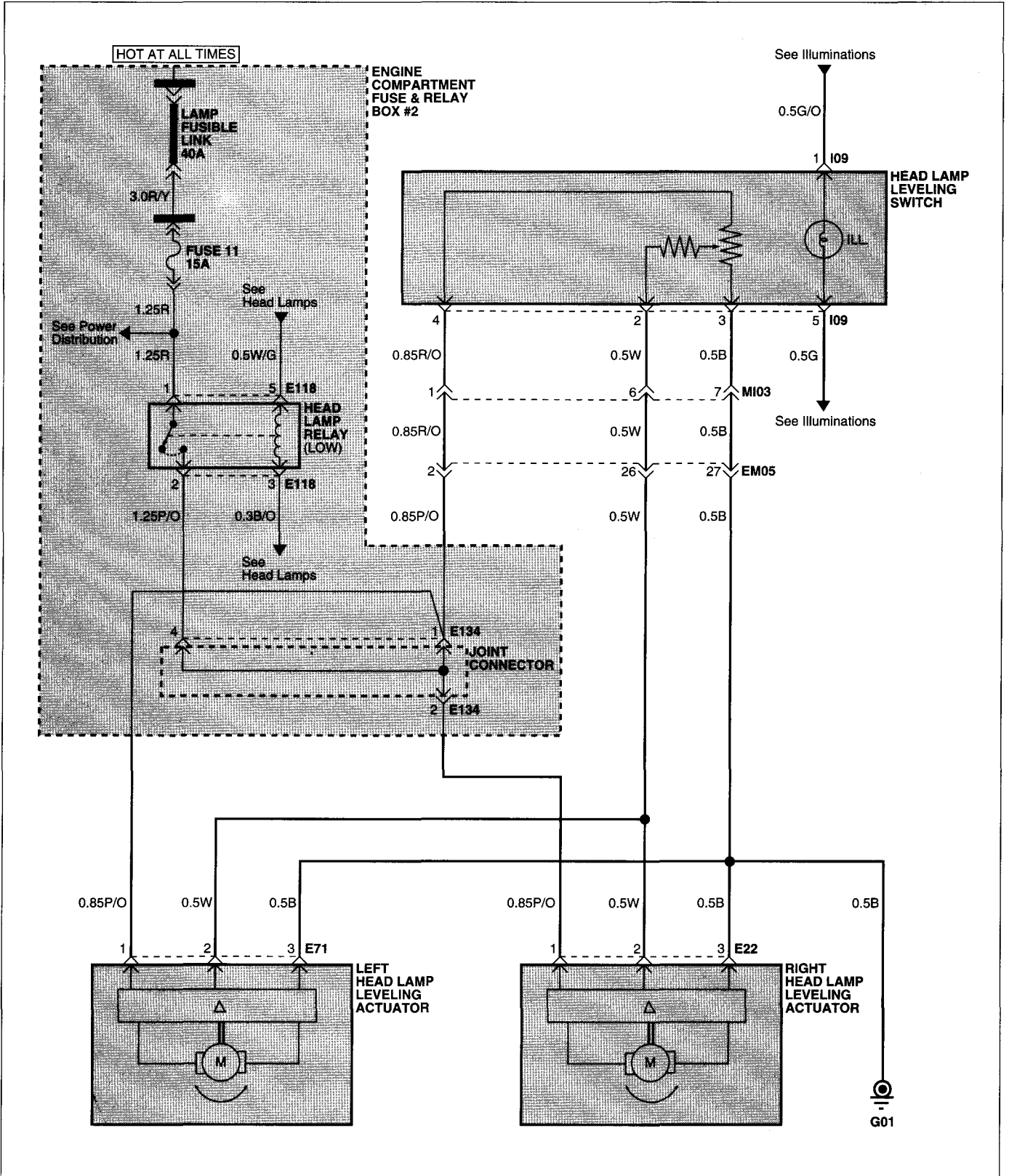

COMPONENT LOCATION INDEX

Components		Location reference - page
E22	Right head lamp leveling actuator	CL- 9
E71	Left head lamp leveling actuator	CL-13
E118	Head lamp relay (Low)	CL-14
E134	Joint connector	CL-14
I09	Head lamp leveling switch	CL-20
Connectors		
EM05		CL-19
MI03		CL- 6
Grounds		
G01		CL-29

Circuit Description

The head lamps should be aimed properly according to the number of the passengers and the loading weight in the luggage area. To adjust the head lamps beam level, turn the head lamp leveling switch. The higher the number of the switch position, the lower the head lamp beam level. Always keep the head lamps beam at the proper leveling position, or head lamp may dazzle other road users.

Battery voltage is supplied to the left/right head lamp leveling actuators in the head lamps from fuse 11 and the beam level can be controlled through a variable resistor (built-in to the head lamp leveling switch)

TURN & HAZARD LAMPS

E068FF2C

TURN & HAZARD LAMPS (1)

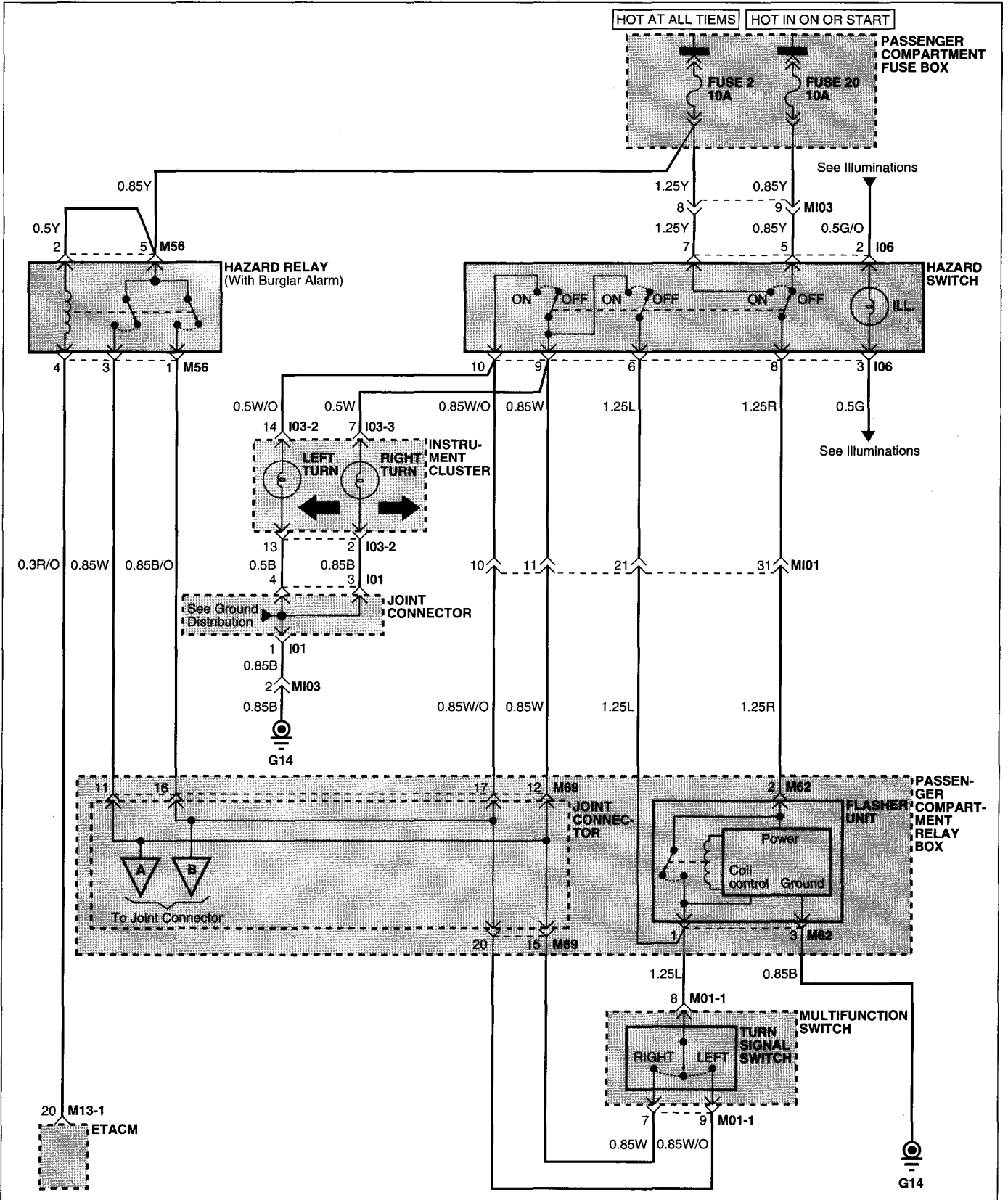

TURN & HAZARD LAMPS (2)

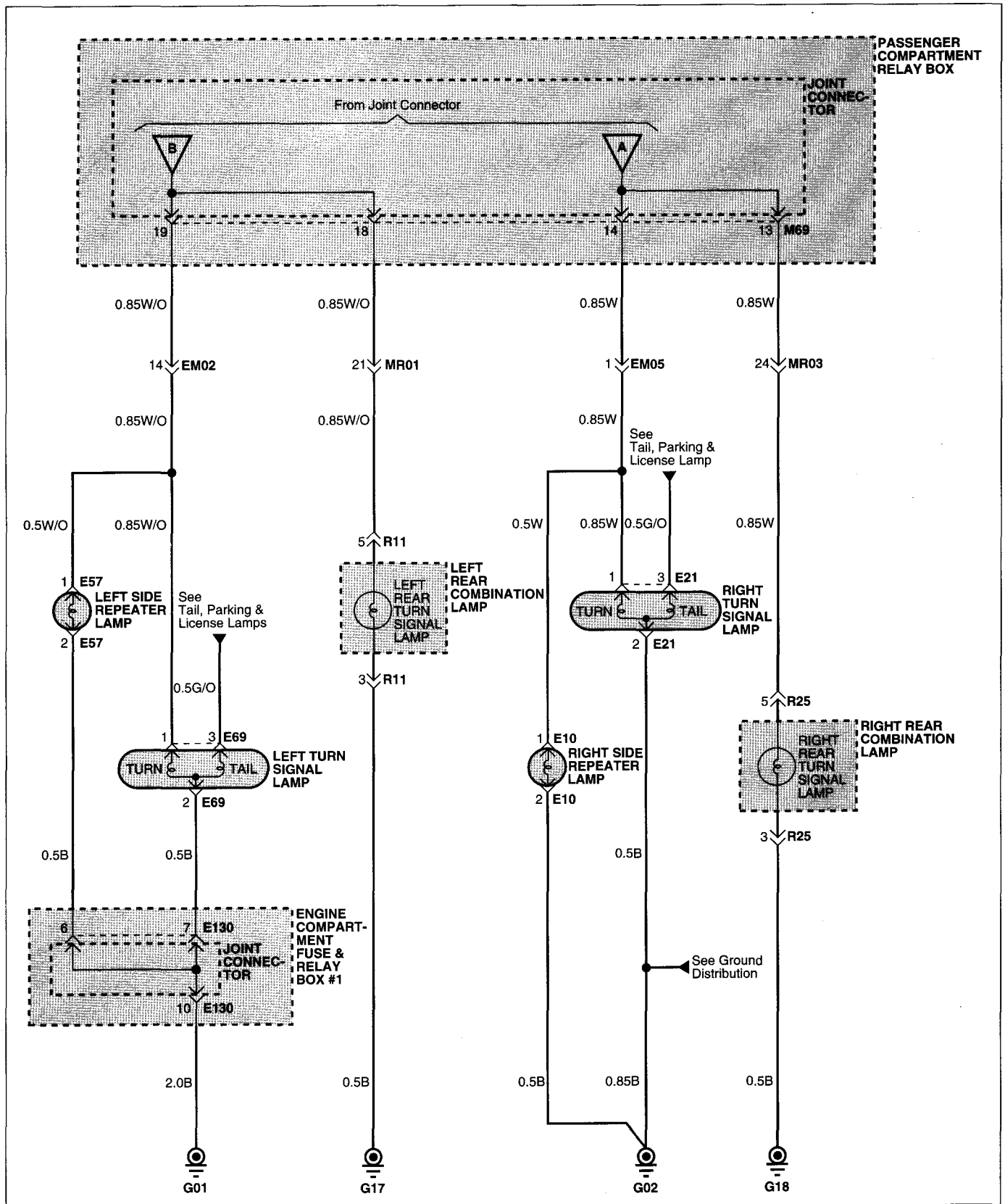

COMPONENT LOCATION INDEX

Components		Location reference - page
E10	Right side repeater lamp	CL- 8
E21	Right turn signal lamp	CL- 9
E57	Left side repeater lamp	CL-12
E69	Left turn signal lamp	CL-13
E130	Joint connector	CL-14
I01	Joint connector	CL-20
I03-2	Instrument cluster	CL-20
I03-3	Instrument cluster	CL-20
I06	Hazard switch	CL-20
M01-1	Multifunction switch	CL- 2
M13-1	ETACM	CL- 2
M56	Hazard switch	CL- 5
M62	Flasher unit	CL- 5
M69	Joint connector	CL- 5
R11	Left rear combination lamp	CL-24
R25	Right rear combination lamp	CL-25
 Connectors		
EM02		CL-19
EM05		CL-19
MI01		CL- 6
MI03		CL- 6
MR01		CL- 7
MR03		CL- 7
 Grounds		
G01		CL-29
G02		CL-29
G14		CL-29
G17		CL-30
G18		CL-30

Circuit Description**Turn Signal Lamps Operation**

With the hazard switch in OFF and ignition switch in ON or START position, battery voltage is applied from fuse 20 to the flasher unit. The solid-state element in the flasher unit senses the turn signal switch position and controls the relay coil. Battery voltage to the turn signal switch alternately applies and removes. Battery voltage is applied to the left or right turn signal lamp and their indicators depending upon the turn signal switch position.

Hazard Lamps Operation

With the hazard switch is depressed (ON), battery voltage is applied from fuse 2 to the flasher unit. The solid-state element in the flasher unit senses the hazard switch ON signal, controls the relay coils, and then alternately applies and removes battery voltage to both the left turn and right turn lamps and indicate at the same time.

FRONT FOG & REAR FOG LAMPS

EA0BBE89

FRONT FOG & REAR FOG LAMPS (1)

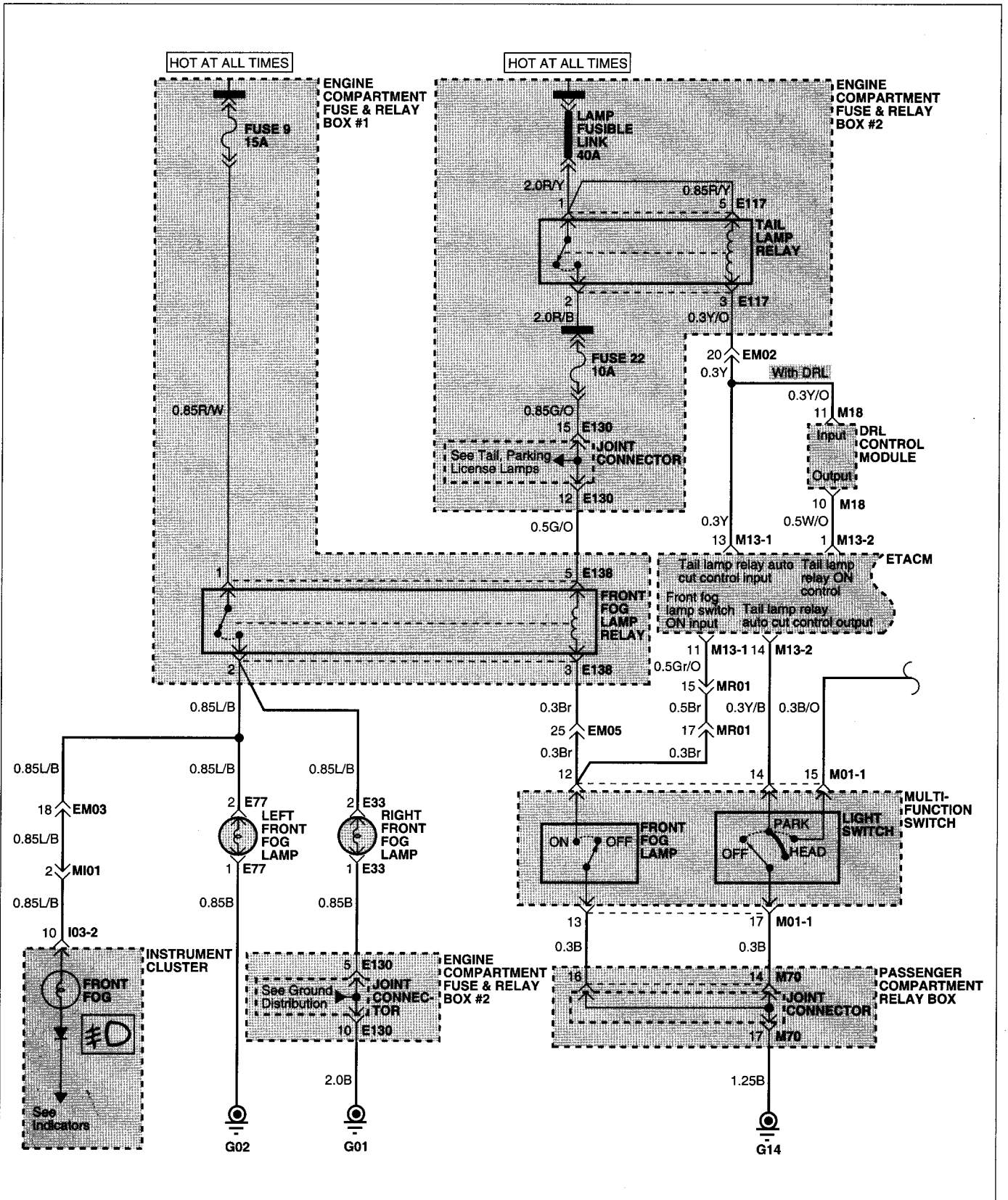

FRONT FOG & REAR FOG LAMPS (2)

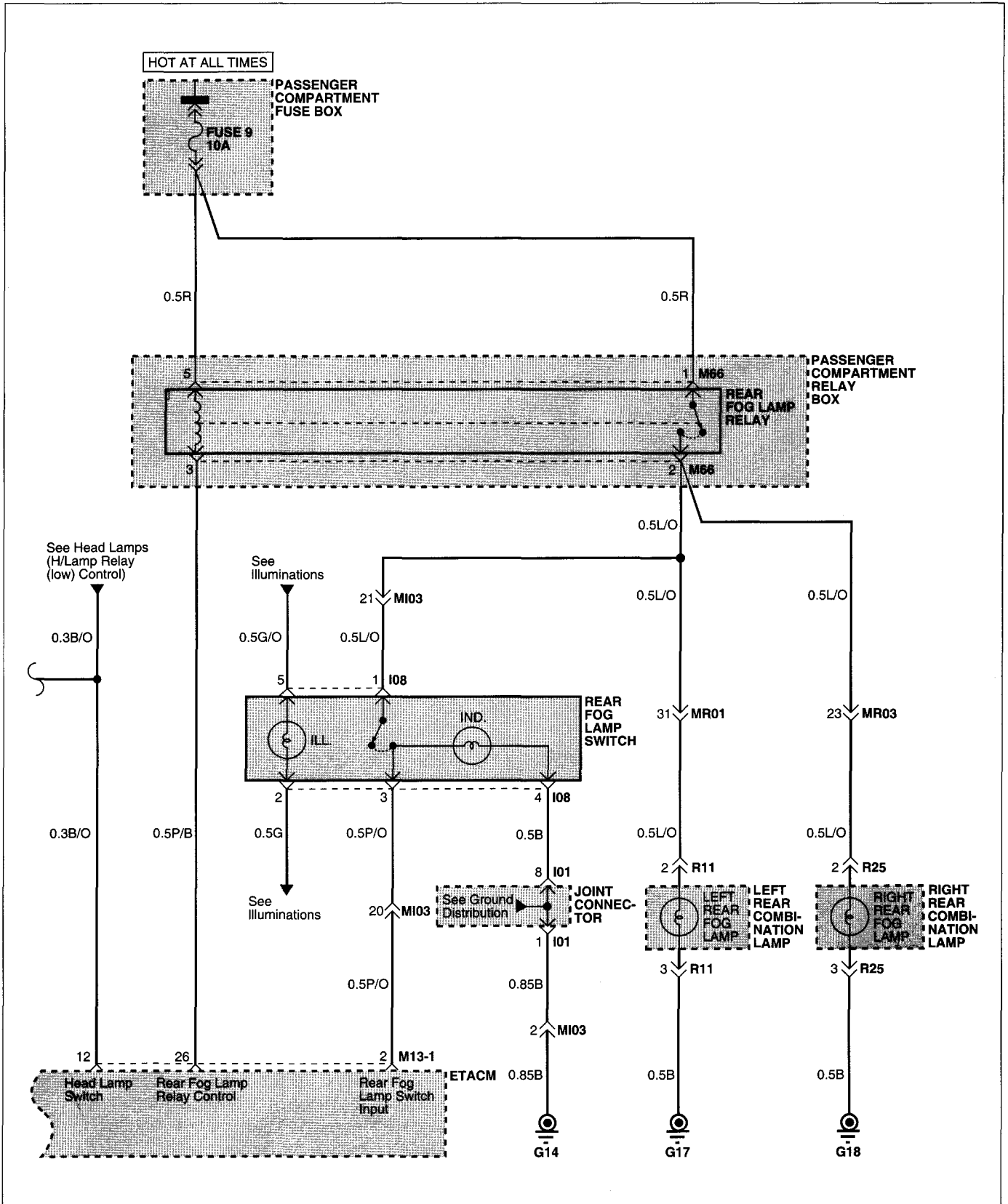

COMPONENT LOCATION INDEX

Components		Location reference - page
E33	Right front fog lamp	CL- 9
E77	Left front fog lamp	CL-13
E117	Tail lamp relay	CL-14
E130	Joint connector	CL-14
E138	Front fog lamp relay	CL-14
I01	Joint connector	CL-20
I03-2	Instrument cluster	CL-20
I08	Rear fog lamp switch	CL-20
M01-1	Multifunction switch	CL- 2
M13-1	ETACM	CL- 2
M13-2	ETACM	CL- 2
M18	DRL control module	CL- 3
M66	Rear fog lamp relay	CL- 5
M70	Joint connector	CL- 5
R11	Left rear combination lamp	CL-24
R25	Right rear combination lamp	CL-25
 Connectors		
EM02		CL-19
EM03		CL-19
EM05		CL-19
MI01		CL- 6
MI03		CL- 6
MR01		CL- 7
MR03		CL- 7
 Grounds		
G01		CL-29
G02		CL-29
G14		CL-29
G17		CL-30
G18		CL-30

Circuit Description

With the light switch in PARK or HEAD, battery voltage is applied to the fog lamp relay coil through the closed contacts of the tail lamp relay. When the fog lamp switch is in ON, the fog lamp relay coil is energized and then battery voltage from the fuse 9 is then provided to the fog lamps through the closed contact of the fog lamp relay. The fog lamps light.

With the ignition switch is ON and the tail lamp switch is ON, battery voltage is applied to the front fog lamp relay coil through the closed contacts of the tail lamp relay. When the head lamp switch or the front fog lamp switch is ON, ETACS control module controls the rear fog lamp relay and ground rear fog signal through the light switch. Then the rear fog lamp switch is ON, the rear fog lamps go on.

TAIL, PARKING & LICENSE LAMPS

EE9E5D46

TAIL, PARKING & LICENSE LAMPS (1)

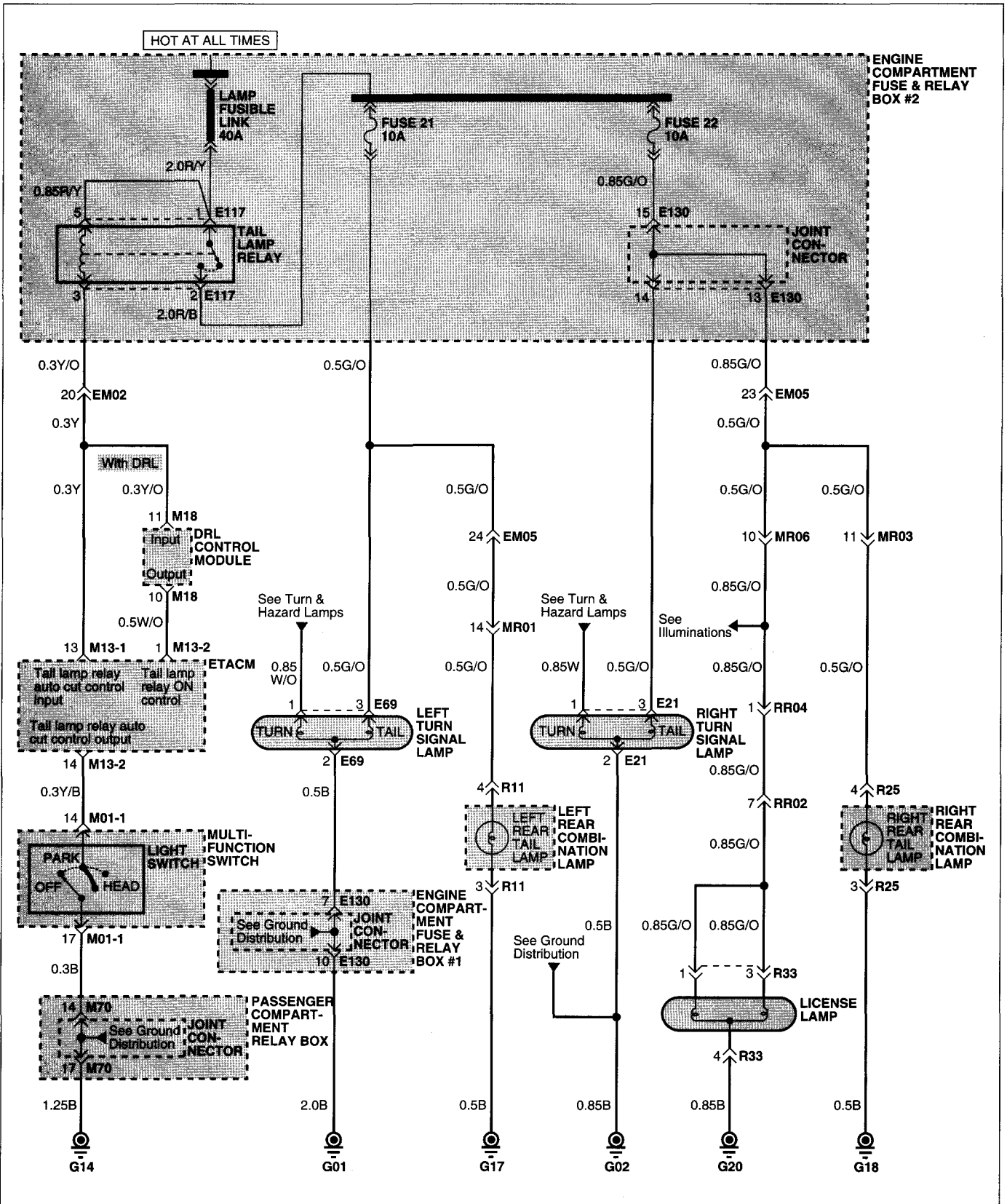

COMPONENT LOCATION INDEX

Components		Location reference- page
E21	Right turn signal lamp	CL- 9
E69	Left turn signal lamp	CL-13
E117	Tail lamp relay	CL-14
E130	Joint connector	CL-14
M01-1	Multifunction switch	CL- 2
M13-1	ETACM	CL- 2
M13-2	ETACM	CL- 2
M18	DRL control module	CL- 3
M70	Joint connector	CL- 5
R11	Left rear combination lamp	CL-24
R25	Right rear combination lamp	CL-28
R33	License lamp	CL-25
Connectors		
EM02		CL-19
EM05		CL-19
MR01		CL- 7
MR03		CL- 7
MR06		CL- 7
RR02		CL-26
RR04		CL-26
Grounds		
G01		CL-29
G02		CL-29
G14		CL-29
G17		CL-30
G18		CL-30
G20		CL-30

Circuit Description

Battery voltage is applied at all times to both the coil and contact of the tail lamp relay from the fusible link. With the light switch in PARK or HEAD, the coil of the tail lamp relay is grounded through the ETACS control module. Battery voltage from the fuse 21,22 is then provided to the Left/Right tail of turn signal lamp, Left/Right rear combination lamps and license lamp through the closed tail lamp relay contact. All the lamps go on.

BACK-UP LAMPS

E84F2368

BACK-UP LAMPS (1)

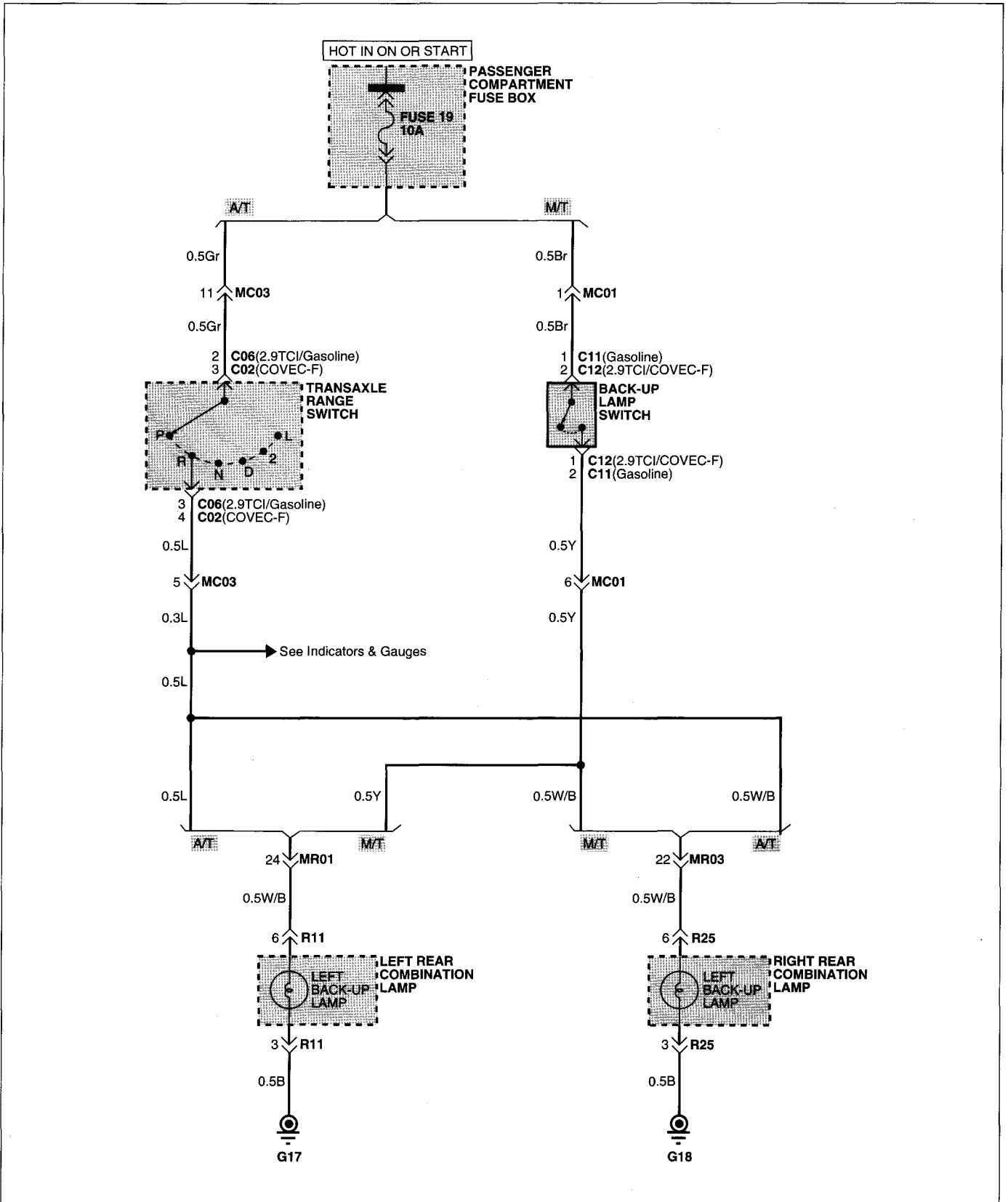

COMPONENT LOCATION INDEX

Components		Location reference - page
C02	Transaxle range switch (COVEC-F)	CL-21
C06	Transaxle range switch (Gasoline/2.9TCI)	CL-21
C12	Back-up lamp switch (2.9TCI/COVEC-F)	CL-21
M69	Joint connector	CL- 5
R11	Left rear combination lamp	CL-24
R25	Right rear combination lamp	CL-25
Connectors		
MC01		CL- 6
MC03		CL- 6
MR01		CL- 7
MR03		CL- 7
Grounds		
G17		CL-30
G18		CL-30

Circuit Description

With the ignition switch in ON or START, battery voltage is applied from Fuse 19 to the transaxle range switch (Automatic transaxle) and back-up lamp switch (Manual transaxle). When the transaxle is in reverse, battery voltage is applied to the back-up lamps and the back-up lamps go on.

COMPONENT LOCATION INDEX

Components		Location reference - page
M10	Condenser	CL- 3
M11	Stop lamp switch	CL- 3
R11	Left rear combination lamp	CL-24
R25	Right rear combination lamp	CL-25
R30	High-mounted stop lamp	CL-25
Connectors		
MR02		CL- 7
MR03		CL- 7
MR06		CL- 7
RR02		CL-26
RR04		CL-26
Grounds		
G17		CL-30
G18		CL-30
G20		CL-30

Circuit Description

Battery voltage is applied to the stop lamp switch at all times from fuse 3. With the brake pedal depressed, the stop lamp switch is closed and battery voltage is applied to all the stop lamps (left/right stop lamps and center high-mounted stop lamp) and the lamps go on.

COURTESY & TAIL GATE LAMPS

E1C431F1

COURTESY & TAIL GATE LAMPS (1)

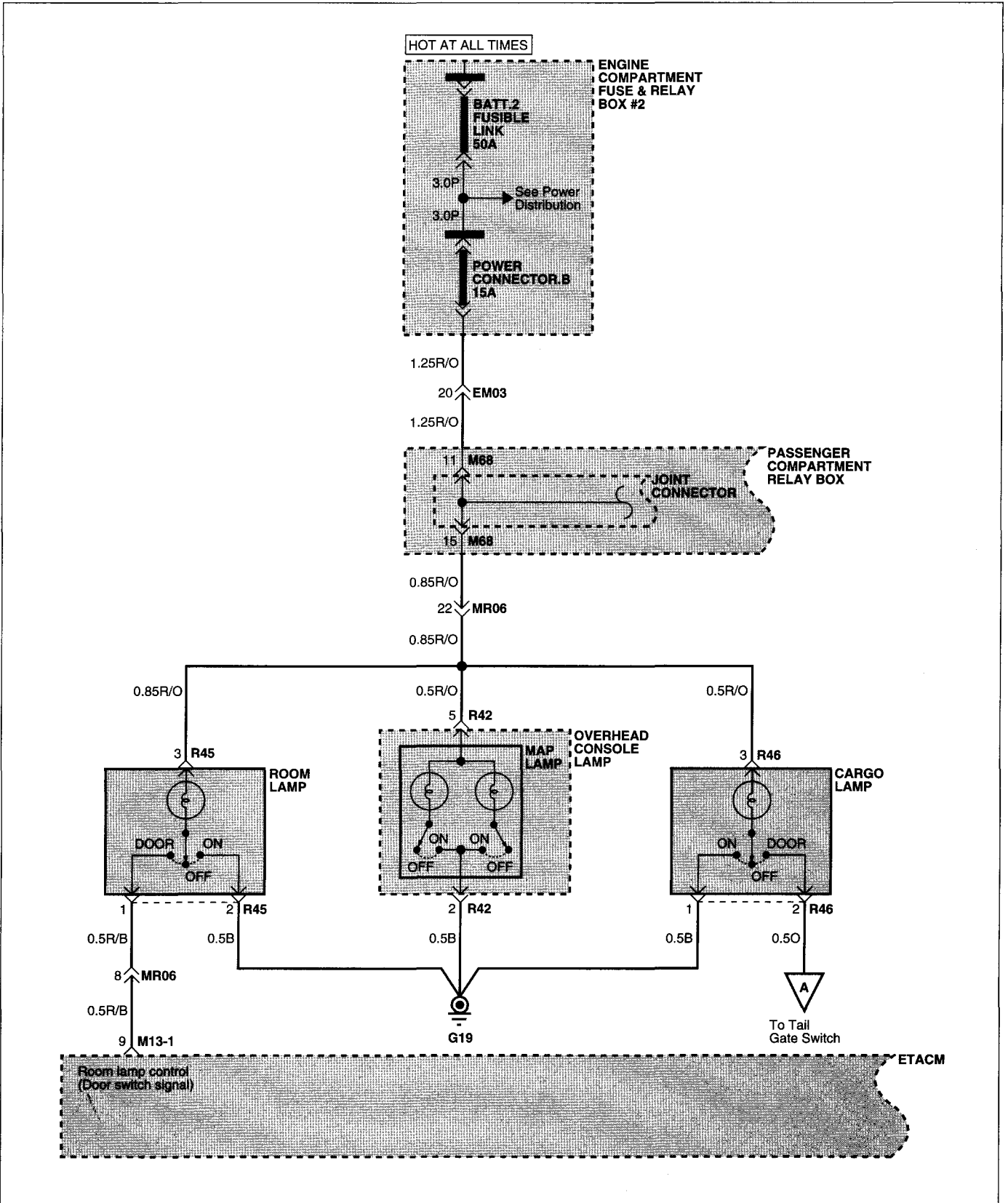

COURTESY & TAIL GATE LAMPS (2)

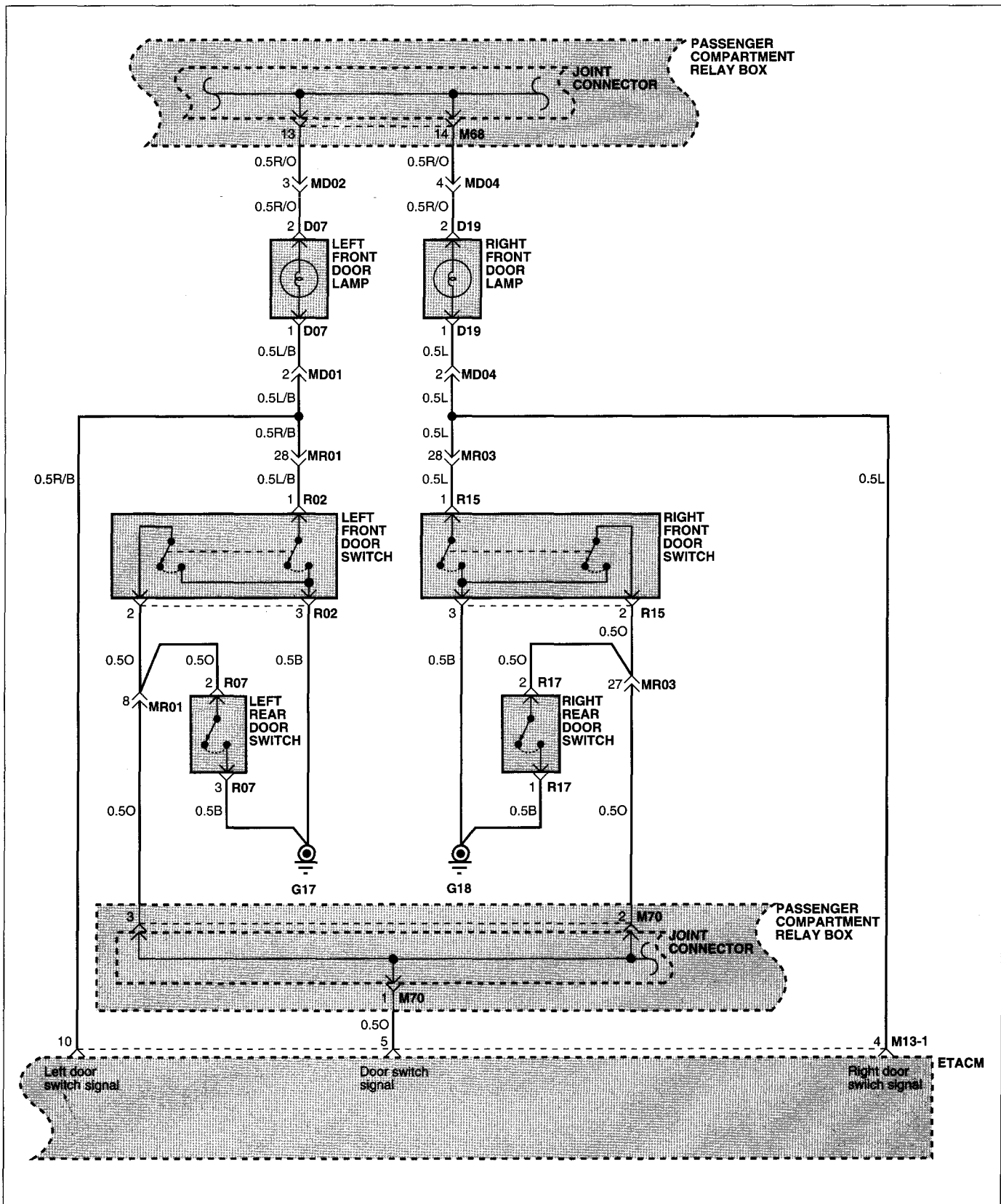

COURTESY & TAIL GATE LAMPS (3)

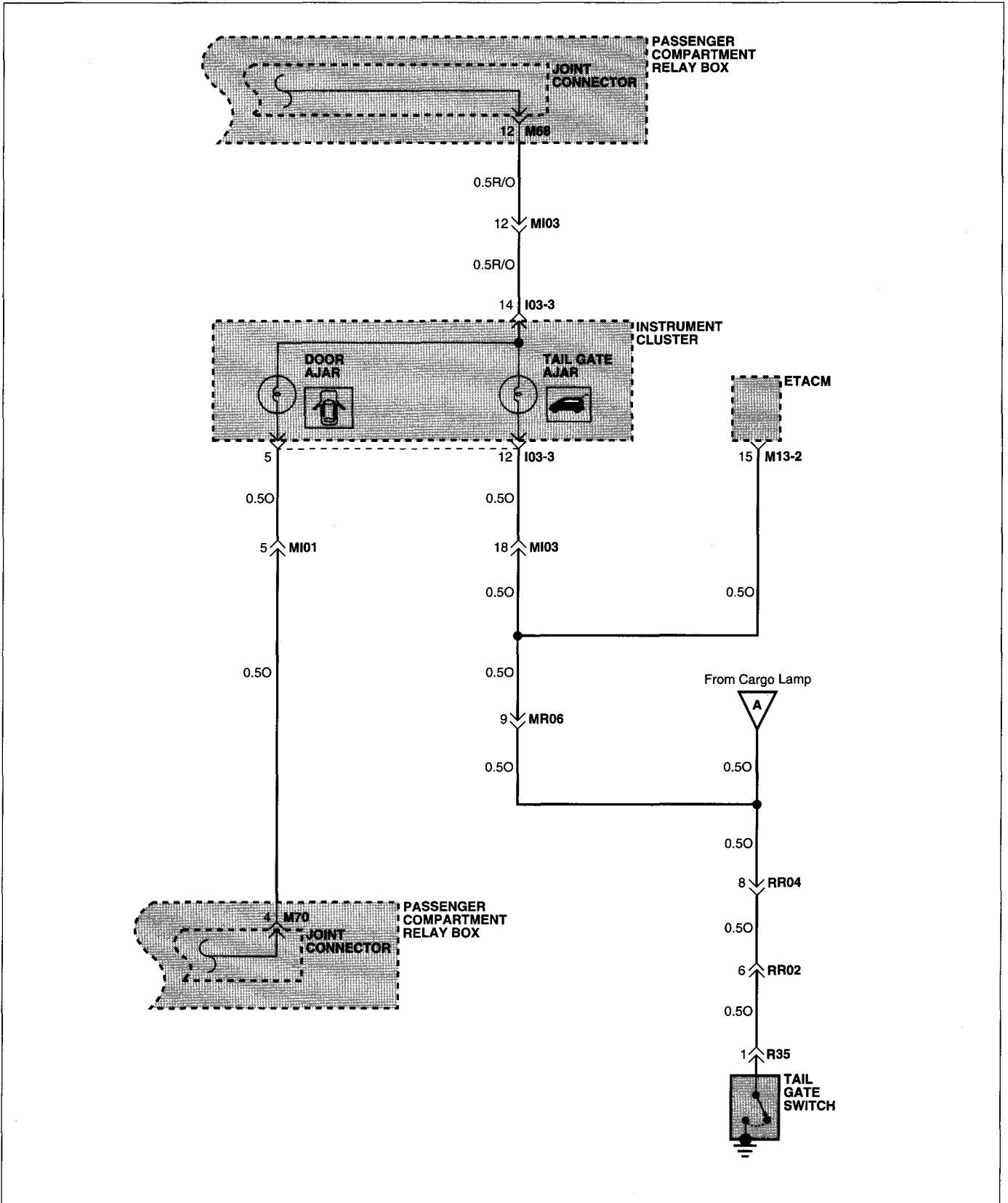

COMPONENT LOCATION INDEX

Components		Location reference - page
D07	Left front door lamp	CL-22
D19	Right front door lamp	CL-22
I03-3	Instrument cluster	CL-20
M13-1	ETACM	CL- 2
M13-2	ETACM	CL- 2
M68	Joint connector	CL- 5
M70	Joint connector	CL- 5
R02	Left front door switch	CL-24
R07	Left rear door switch	CL-24
R15	Right front door switch	CL-24
R17	Right rear door switch	CL-24
R35	Tail gate switch	CL-25
R42	Overhead console lamp	CL-26
R45	Room lamp	CL-26
R46	Cargo lamp	CL-26
Connectors		
EM03		CL-19
MD01		CL- 6
MD02		CL- 6
MD04		CL- 6
MI01		CL- 6
MI03		CL- 6
MR01		CL- 7
MR03		CL- 7
MR06		CL- 7
RR02		CL-26
Grounds		
G17		CL-30
G18		CL-30
G19		CL-30

Circuit Description

Battery voltage is applied at all times from power connector B to the map lamps in the overhead console lamp, the room lamp, the cargo lamp, the door ajar, the tail gate ajar warning indicators and the left/right front door lamp. When the appropriate lamp switch is closed, a ground path is provided to the respective lamps through the ETACS control module, causing the lamps to go on.

The room lamp is controlled not only by the door switch (controlled by ETACS control module) but also by the room lamp switch in the room lamp. They are turned on and off manually. The room lamp can be turned on and off manually, depending on the position of the room lamp switch. The room lamp can also be turned off so it will not come on with the door open. The tail gate ajar warning indicator lights turn on when the rear window switch or the tail gate switch is closed.

ILLUMINATIONS

E64F33BE

ILLUMINATIONS (1)

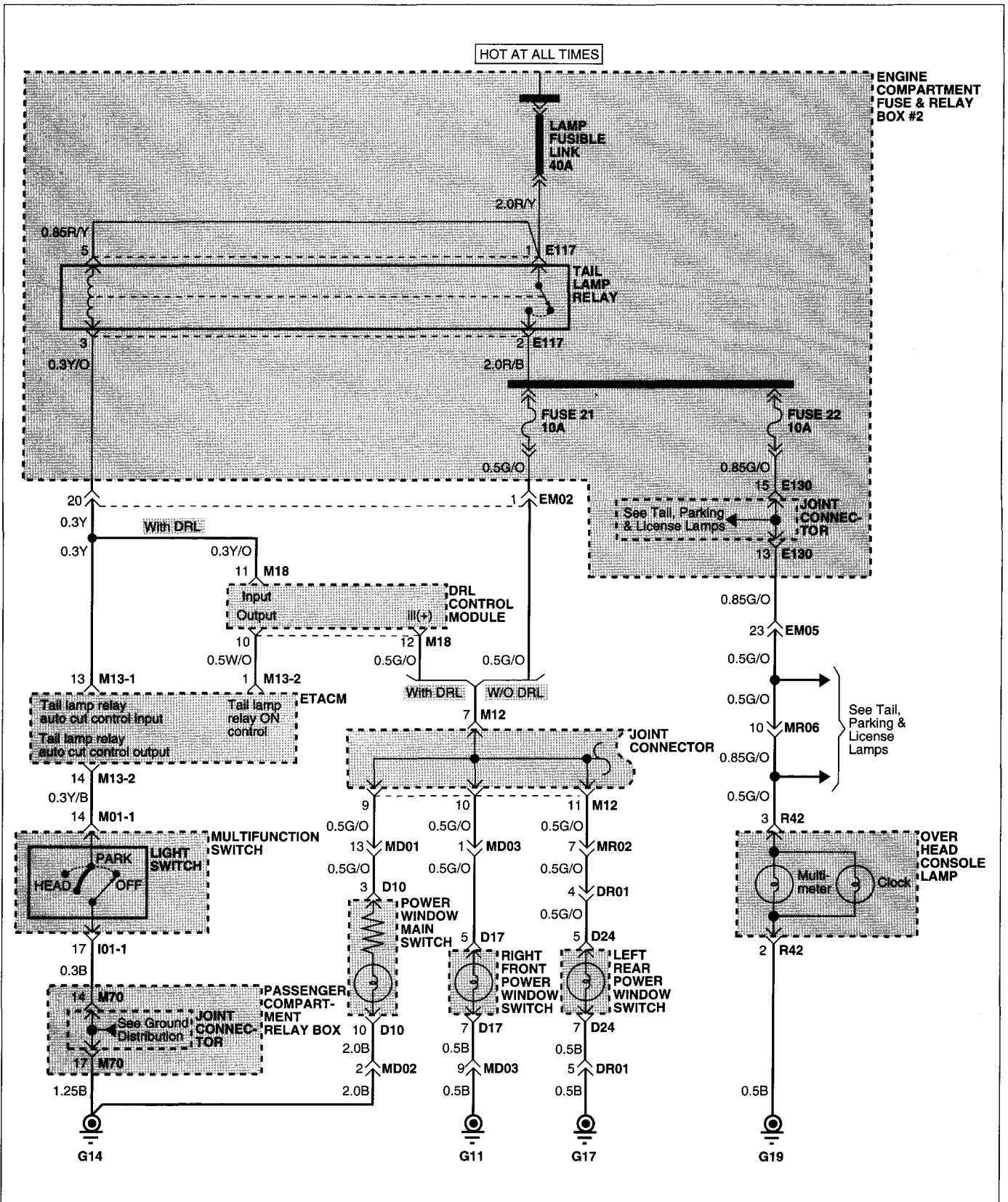

ILLUMINATIONS (2)

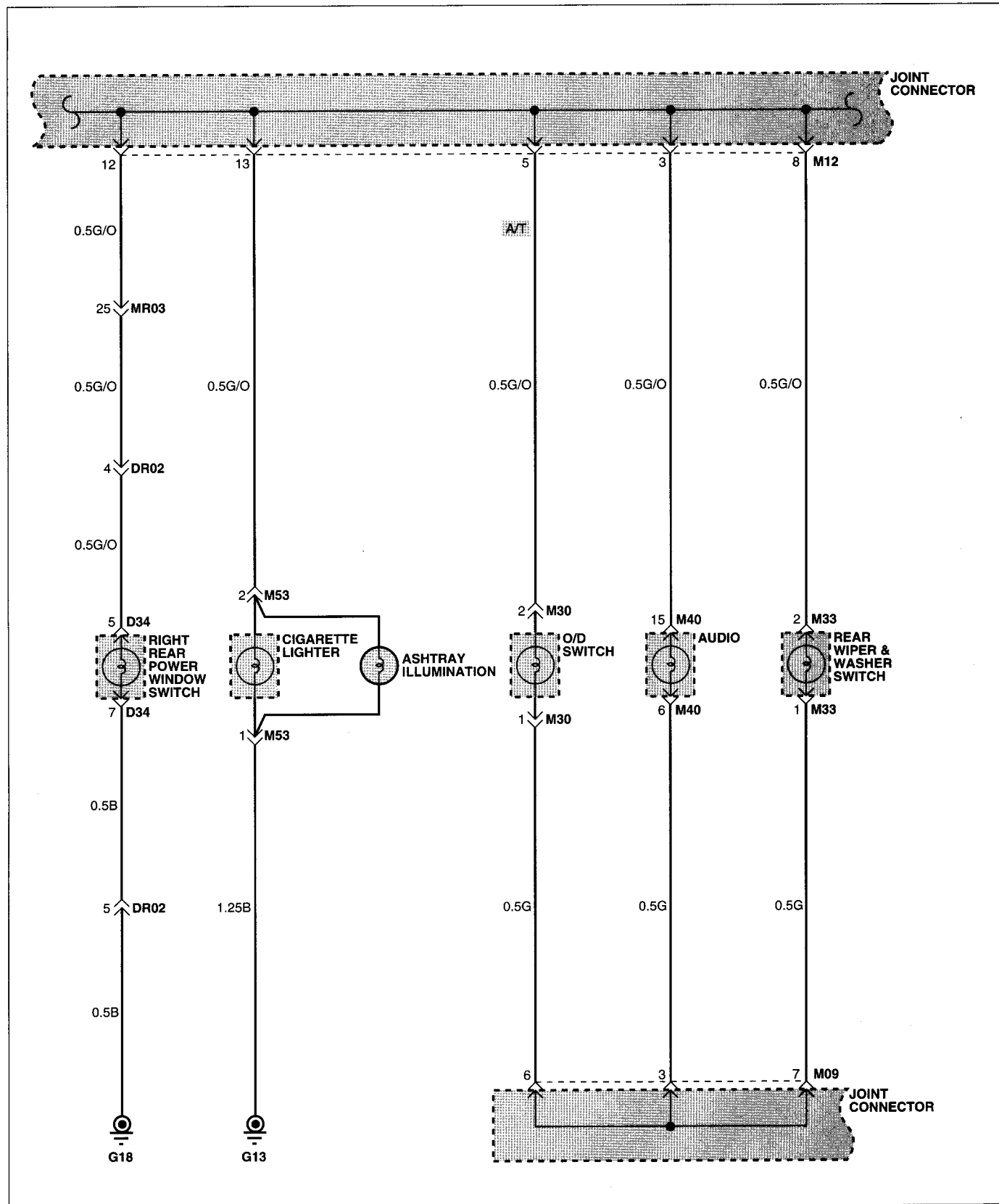

ILLUMINATIONS (3)

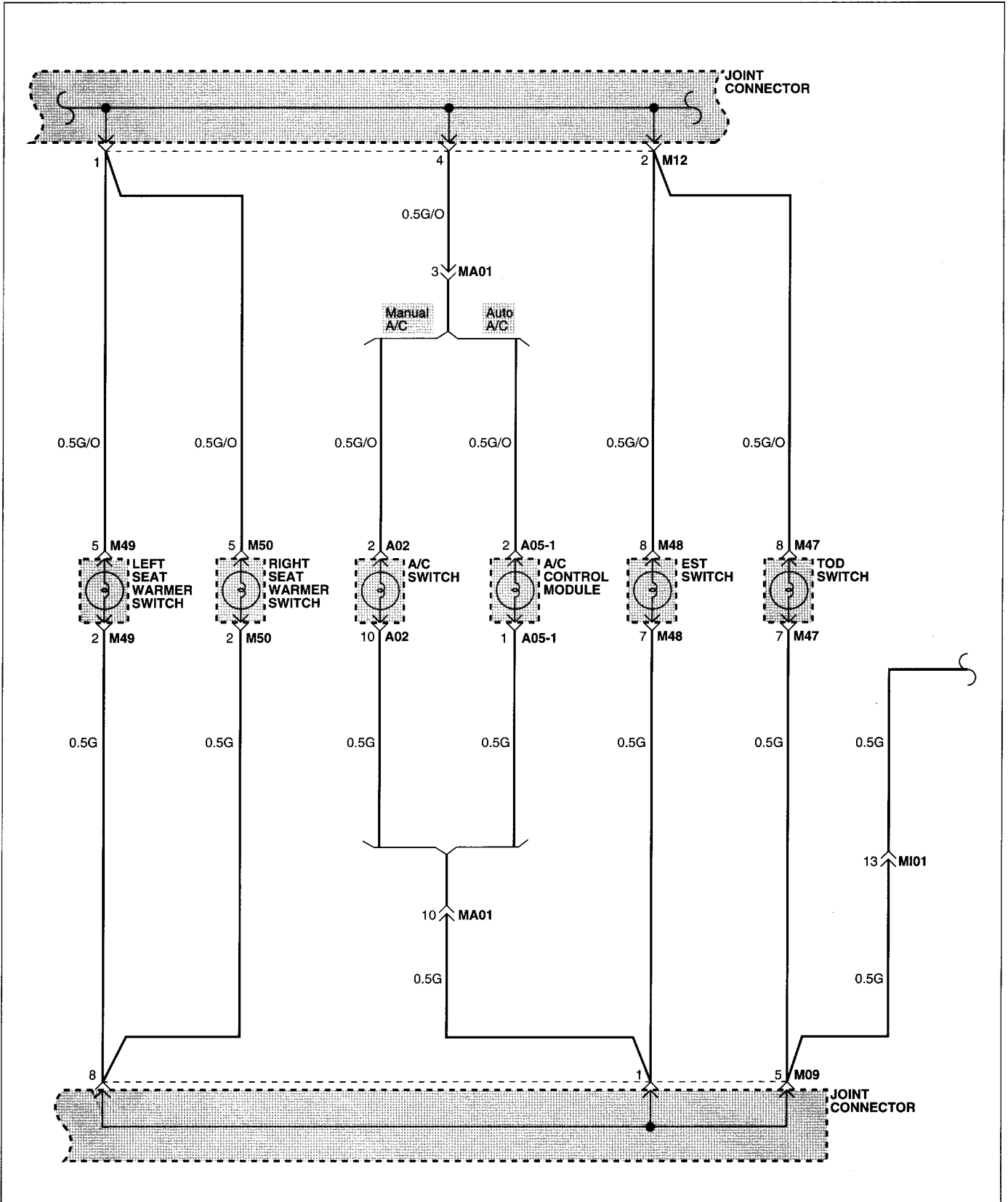

ILLUMINATIONS (4)

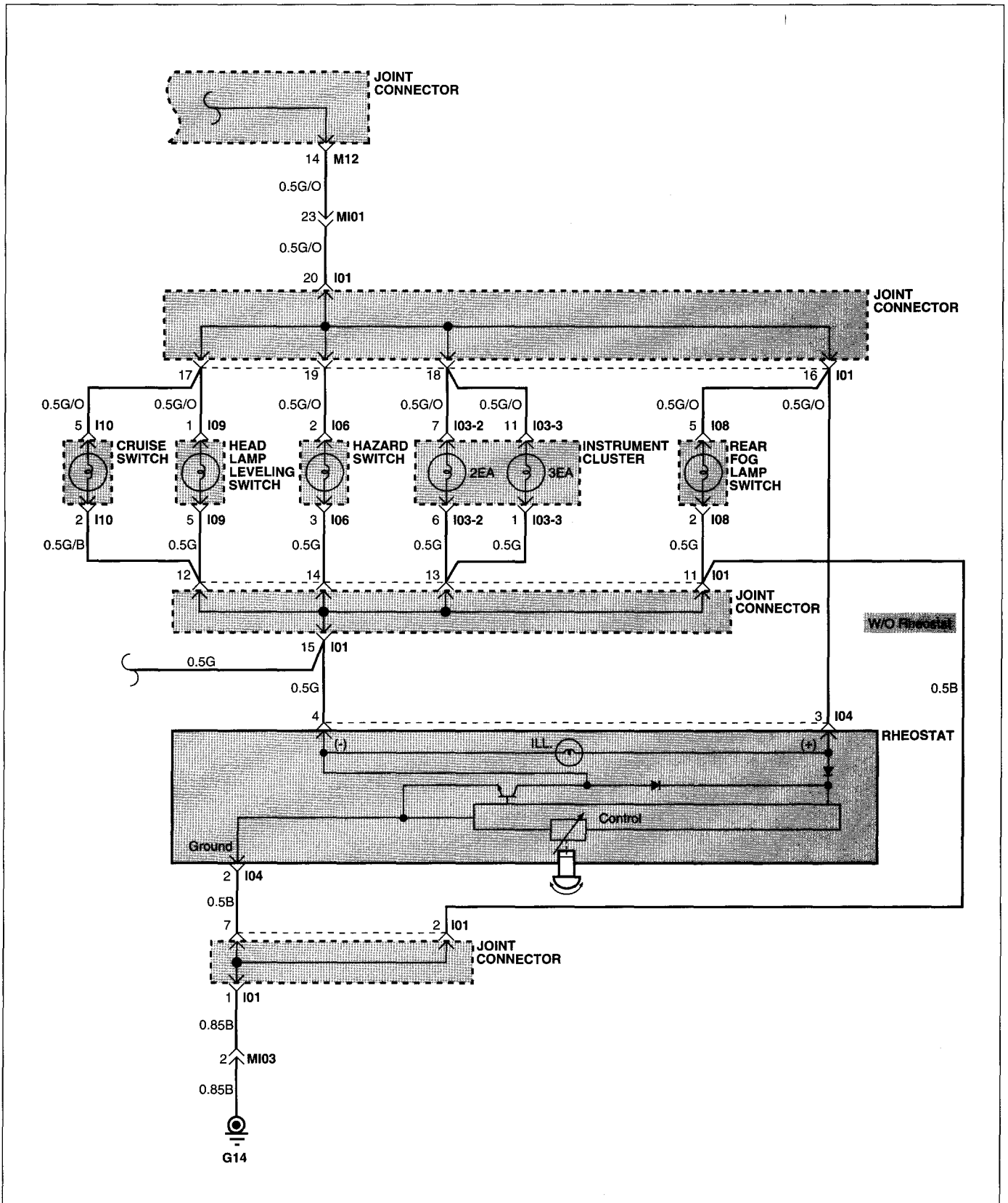

COMPONENT LOCATION INDEX

Components		Location reference - page
A02	A/C switch (Manual A/C)	CL-27
A05-1	A/C control module (Auto A/C)	CL-27
D10	Power window main switch	CL-22
D17	Right front power window switch	CL-22
D24	Left rear power window switch	CL-23
D34	Right rear power window switch	CL-23
E117	Tail lamp relay	CL-14
E130	Joint connector	CL-14
I01	Joint connector	CL-20
I03-2	Instrument cluster	CL-20
I03-3	Instrument cluster	CL-20
I04	Rheostat	CL-20
I06	Hazard switch	CL-20
I08	Rear fog lamp switch	CL-20
I09	Head lamp leveling switch	CL-20
I10	Cruise switch	CL-20
M01-1	Multifunction switch	CL- 2
M09	Joint connector	CL- 2
M12	Joint connector	CL- 2
M13-1	ETACM	CL- 2
M13-2	ETACM	CL- 2
M18	DRL control module	CL- 3
M30	O/D switch	CL- 4
M33	Rear wiper & washer switch	CL- 4
M40	Audio	CL- 4
M47	TOD switch	CL- 4
M48	EST switch	CL- 4
M49	Left seat warmer switch	CL- 4
M50	Right seat warmer switch	CL- 4
M53	Cigarette lighter	CL- 4
M70	Joint connector	CL- 5
R42	Overhead console lamp	CL-26

COMPONENT LOCATION INDEX

Connectors	Location reference - page
DR01	CL-23
DR02	CL-23
EM02	CL-19
EM05	CL-19
MA01	CL- 6
MD01	CL- 6
MD02	CL- 6
MD03	CL- 6
MI01	CL- 6
MI03	CL- 6
MR02	CL- 7
MR03	CL- 7
MR06	CL- 7
Grounds	
G11	CL-29
G13	CL-29
G14	CL-29
G17	CL-30
G18	CL-30
G19	CL-30

Circuit Description

Battery voltage is applied to the coil and contact of the tail lamp relay from the lamp fusible link. With the light switch (multifunction switch) in PARK or HEAD, ground is provided to the tail lamp relay coil through the light switch. Battery voltage is then provided to the illumination lamps through the closed contact of the tail lamp relay.

Ground is provided to the some illumination lamps through the rheostat. The rheostat controls the brightness of the lamp.

AIR BAG SYSTEM EC58DC3E

AIR BAG SYSTEM (1)

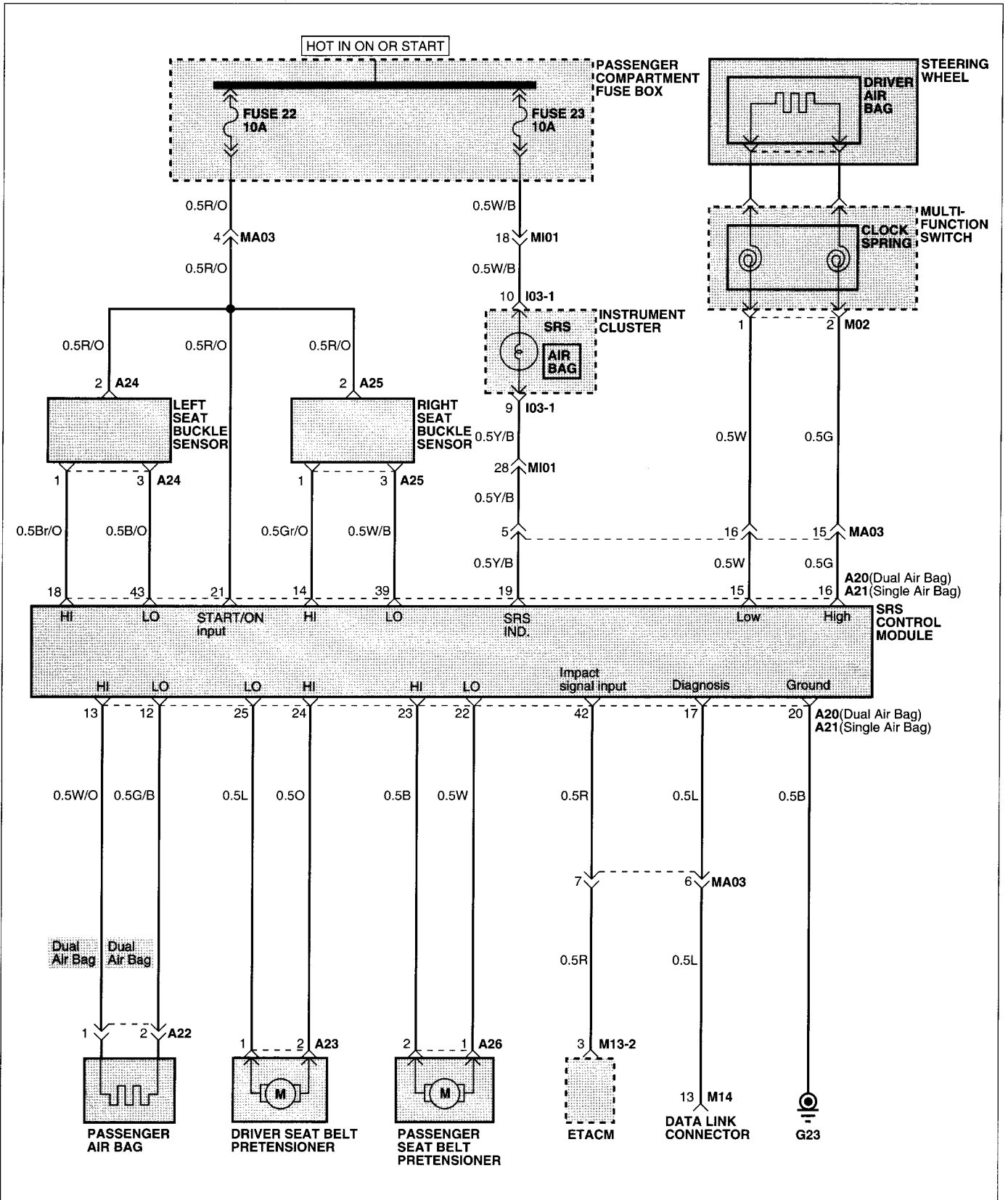

COMPONENT LOCATION INDEX

Componetns		Location reference - page
A20	SRS control module (Dual air bag)	CL-28
A21	SRS control module (Single air bag)	CL-28
A22	Passenger air bag	CL-28
A23	Driver seat belt pretensioner	CL-28
A24	Left seat buckle sensor	CL-28
A25	Right seat buckle sensor	CL-28
A26	Passenger seat belt pretensioner	CL-28
I03-1	Instrument cluster	CL-20
M02	Passenger air bag	CL- 2
M13-2	ETACM	CL- 2
M14	Data link connector	CL- 2
Connectors		
EM05		CL-19
MA03		CL- 6
MI01		CL- 6
Grounds		
G23		CL-30

Circuit Description

Only authorized service personnel should do work on or around the supplemental restraint system (SRS) components. Service personnel should read section RT of the service manual carefully before starting work on the SRS.

The SRS is a safety device which, when used in conjunction with the seat belts, is designed to protect the driver and front seat passenger by deploying air bags when the SRS control module detects impact signals exceeding a certain set limit.

With the ignition switch in ON or START, battery voltage is applied to the SRS control module from fuse 22 and to the SRS indicator in the instrument cluster from fuse 23. When the ignition switch is turned to the ON position, the SRS indicator in the instrument cluster will flash six times. If the SRS indicator does not flash six times, stays on, or comes on while driving, the SRS is not working properly. Refer to the shop manual, section RT for details.

CRUISE CONTROL SYSTEM

EC2BB593

CRUISE CONTROL SYSTEM (1)

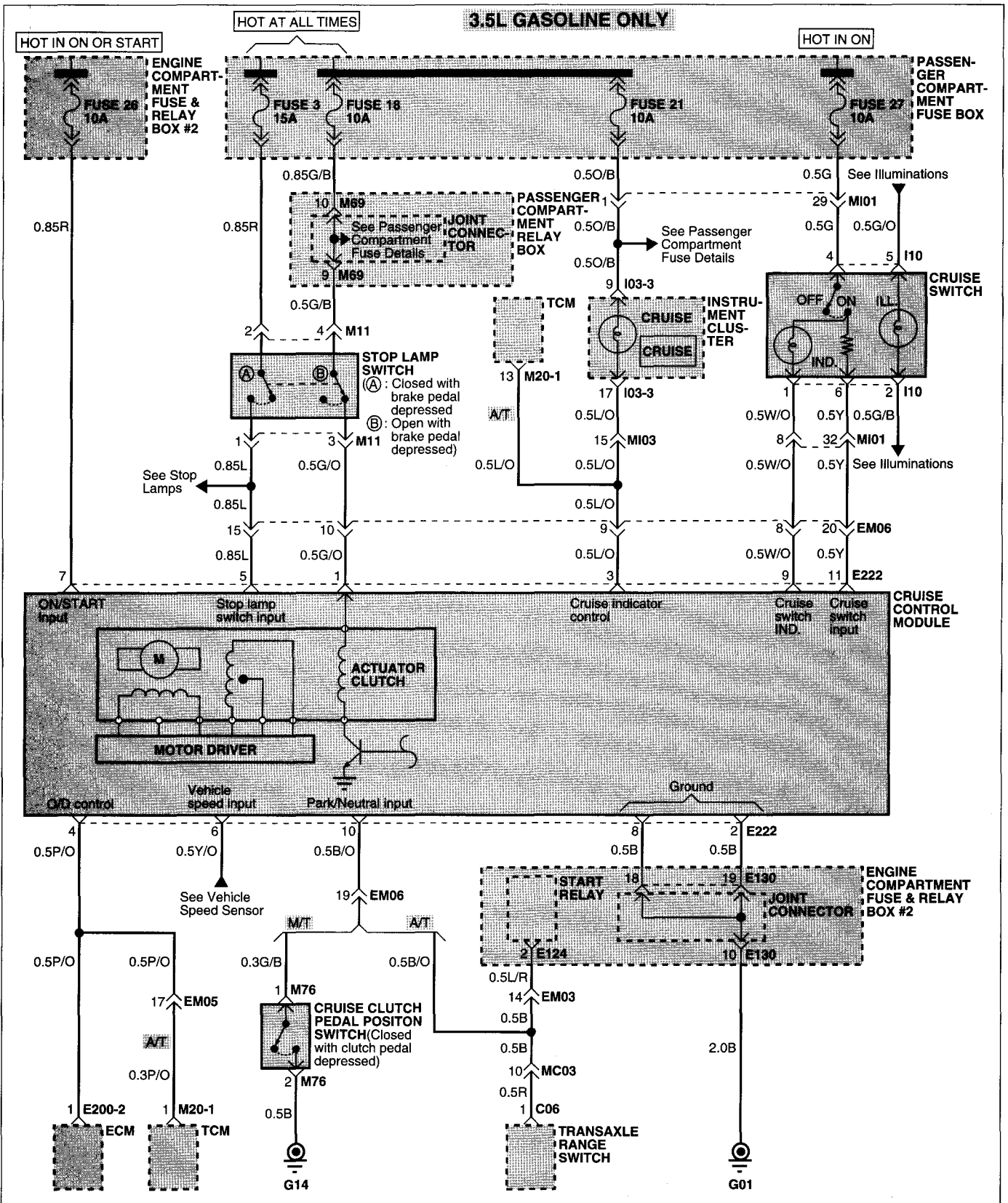

COMPONENT LOCATION INDEX

Components		Location reference - page
C06	Transaxle range switch	CL-21
E124	Start relay	CL-14
E130	Joint connector	CL-14
E200-2	ECM	CL-16
E222	Cruise control module	CL-17
I03-3	Instrument cluster	CL-20
I10	Cruise switch	CL-20
M11	Stop lamp switch	CL- 3
M20-1	TCM	CL- 3
M69	Joint connector	CL- 5
M76	Cruise clutch pedal position switch	CL- 5
Connectors		
EM03		CL-19
EM05		CL-19
EM06		CL-19
MC03		CL- 6
MI01		CL- 6
MI03		
Grounds		
G01		CL-29
G14		CL-29

BLOWER & A/C CONTROLS (AUTO)

ED90DCA6

BLOWER & A/C CONTROLS (AUTO) (1)

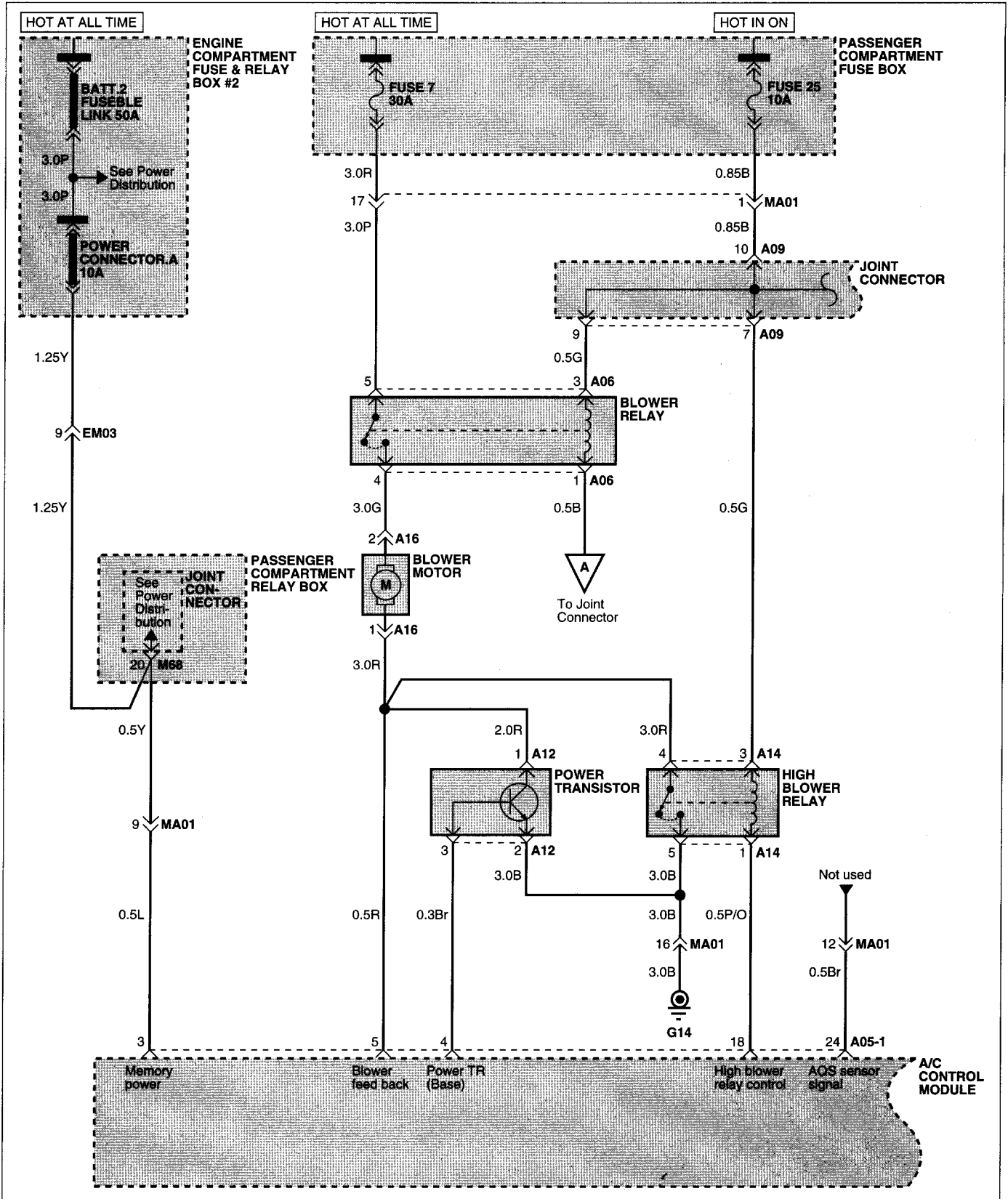

BLOWER & A/C CONTROLS (AUTO) (2)

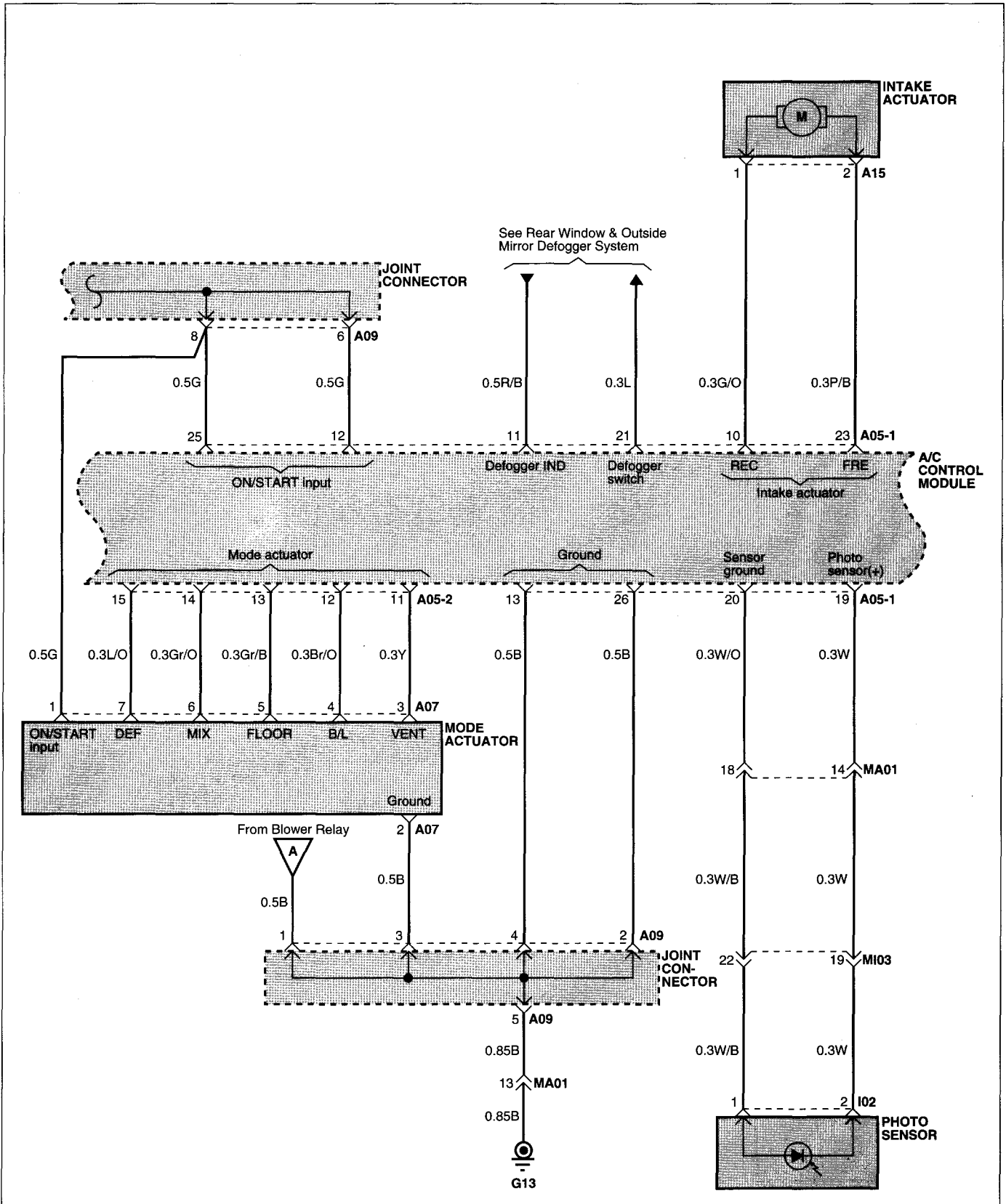

BLOWER & A/C CONTROLS (AUTO) (3)

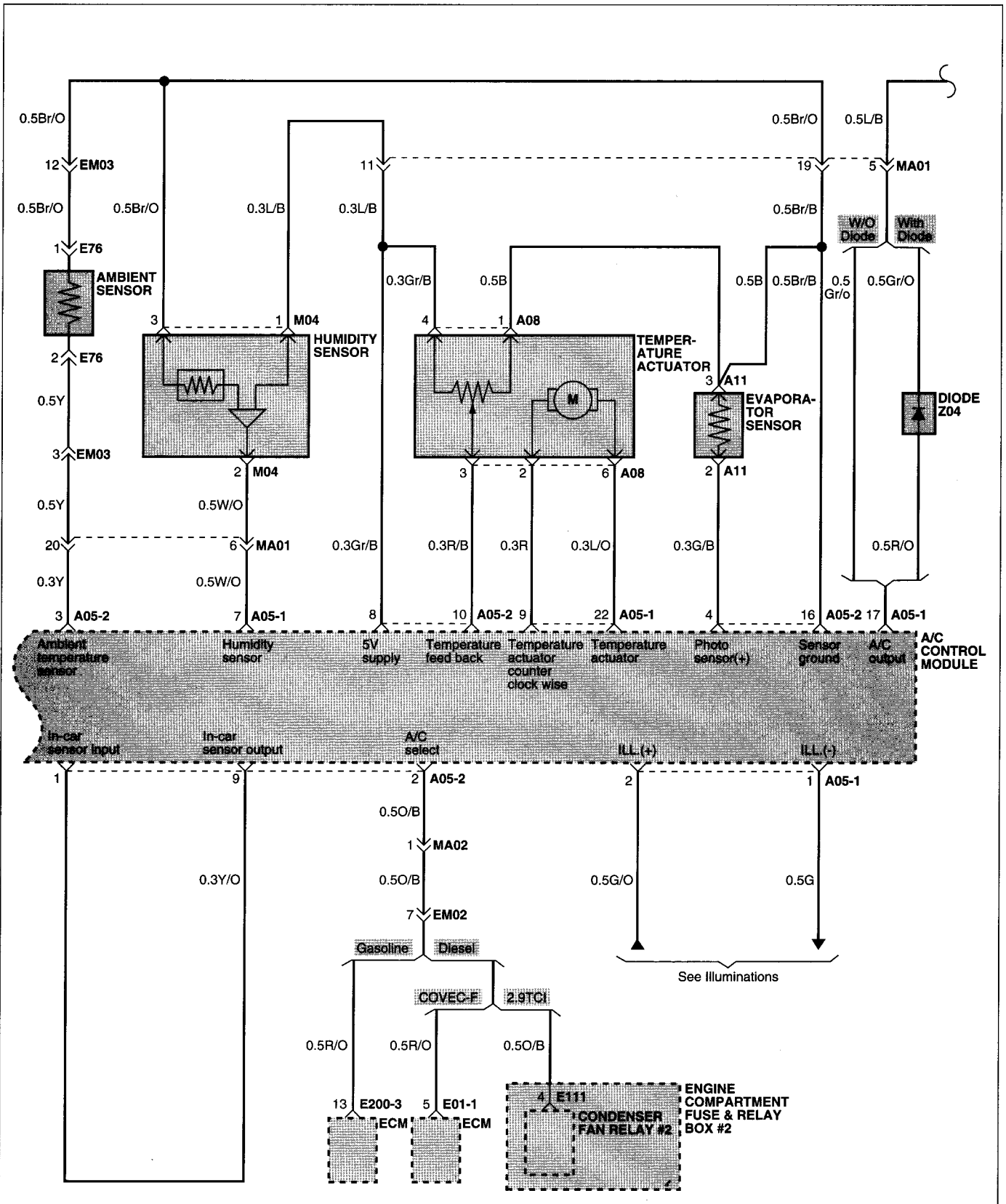

BLOWER & A/C CONTROLS (AUTO) (4)

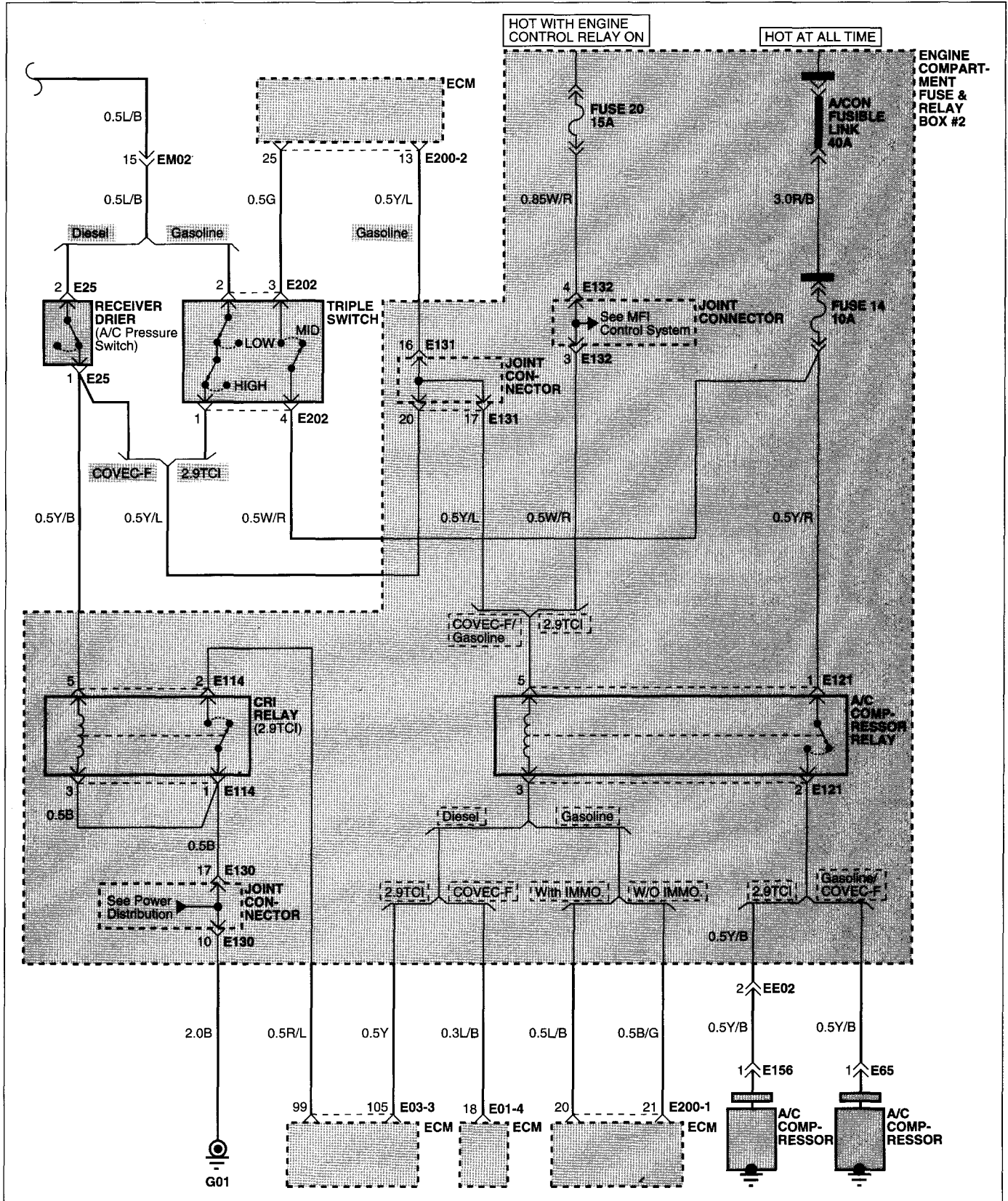

COMPONENT LOCATION INDEX

Components		Location reference- page
A05-1	A/C control module	CL-27
A05-2	A/C control module	CL-27
A06	Blower relay	CL-27
A07	Mode actuator	CL-27
A08	Temperature actuator	CL-27
A09	Joint connector	CL-27
A11	Evaporator sensor	CL-27
A12	Power transistor	CL-27
A14	High blower relay	CL-27
A15	Intake actuator	CL-27
A16	Blower motor	CL-28
E01-1	ECM (COVEC-F)	CL- 8
E01-4	ECM (COVEC-F)	CL- 8
E03-3	ECM (2.9TCI)	CL- 8
E25	Receiver drier	CL- 9
E65	A/C compressor (Gasoline/COVEC-F)	CL-12
E76	Ambient sensor	CL-13
E111	Condenser fan relay	CL-14
E114	CRI relay (2.9TCI)	CL-14
E121	A/C compressor relay	CL-14
E130	Joint connector	CL-14
E131	Joint connector	CL-14
E132	Joint connector	CL-14
E156	A/C compressor (2.9TCI)	CL-15
E200-1	ECM (Gasoline)	CL-16
E200-2	ECM (Gasoline)	CL-16
E200-3	ECM (Gasoline)	CL-16
E202	Triple switch (Gasoline)	CL-16
I02	Photo sensor	CL-20
M04	Humidity sensor	CL- 2
M68	Joint connector	CL- 5
Connectors		
EE02		CL-18
EM02		CL-19
EM03		CL-19
MA01		CL- 6
MI03		CL- 6
Grounds		
G01		CL-29
G13		CL-29
G14		CL-29

Circuit Description

The A/C control module receives input signals (for instance, photo sensor, evaporator sensor, water temperature sensor, ambient temperature sensor, etc) and controls the operation of air conditioning system.

The A/C control module and various sensor signals provide accurate control of air mixture using mode actuator, temperature actuator and intake actuator under all operating conditions.

The blower motor runs at the highest speed when the high blower relay coil is energized through A/C control module.

With the A/C switch in ON, the engine control module (ECM)

will ground the coil of the A/C control relay after a short delay to adjust idle speed.

The function of the power transistor is that of the blower resistor in manual A/C. The power transistor is controlled by the input currents applied to the power transistor BASE terminal.

BLOWER & A/C CONTROL (MANUAL)

EEAD4A5F

BLOWER & A/C CONTROL (MANUAL) (1)

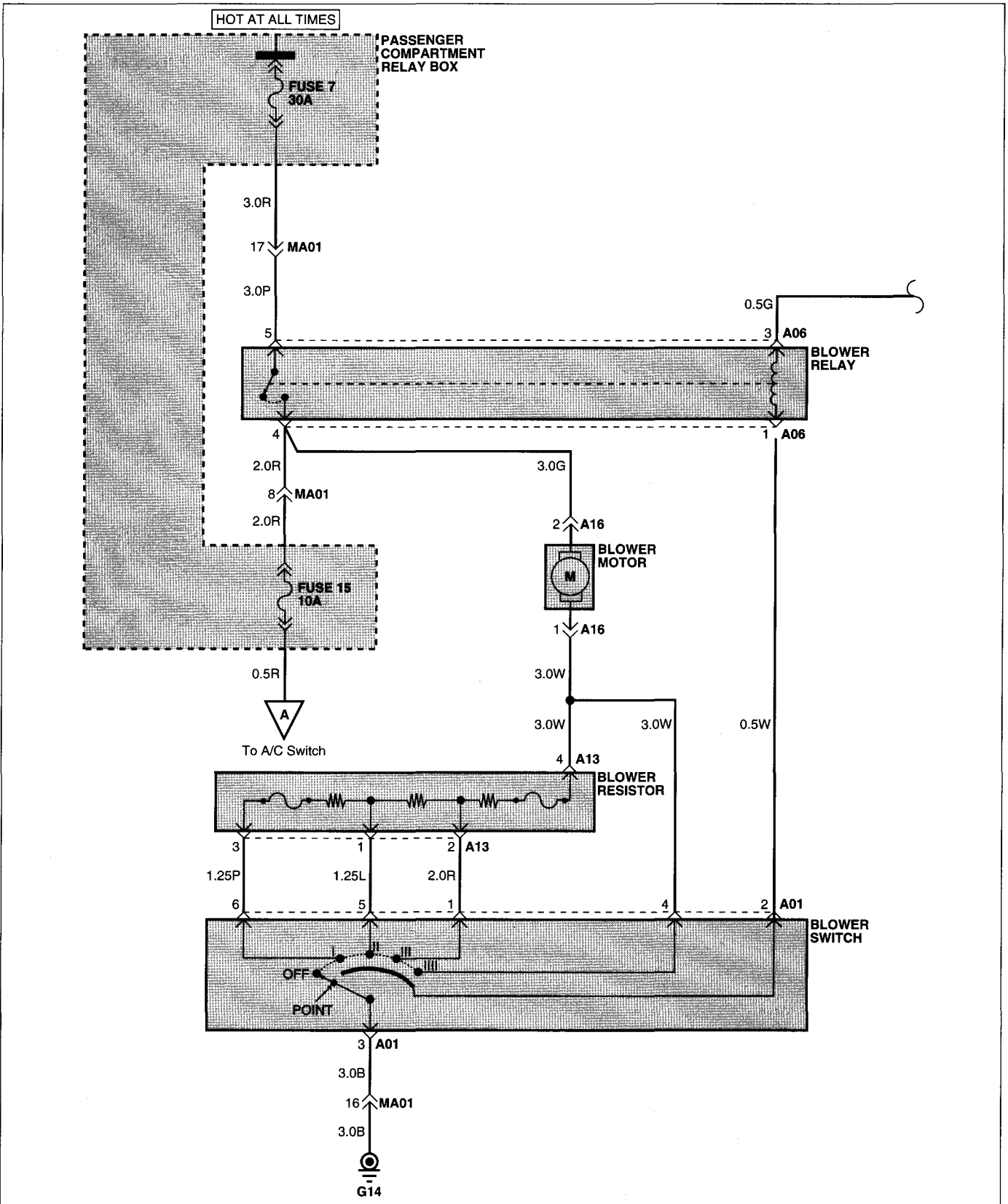

BLOWER & A/C CONTROL (MANUAL) (2)

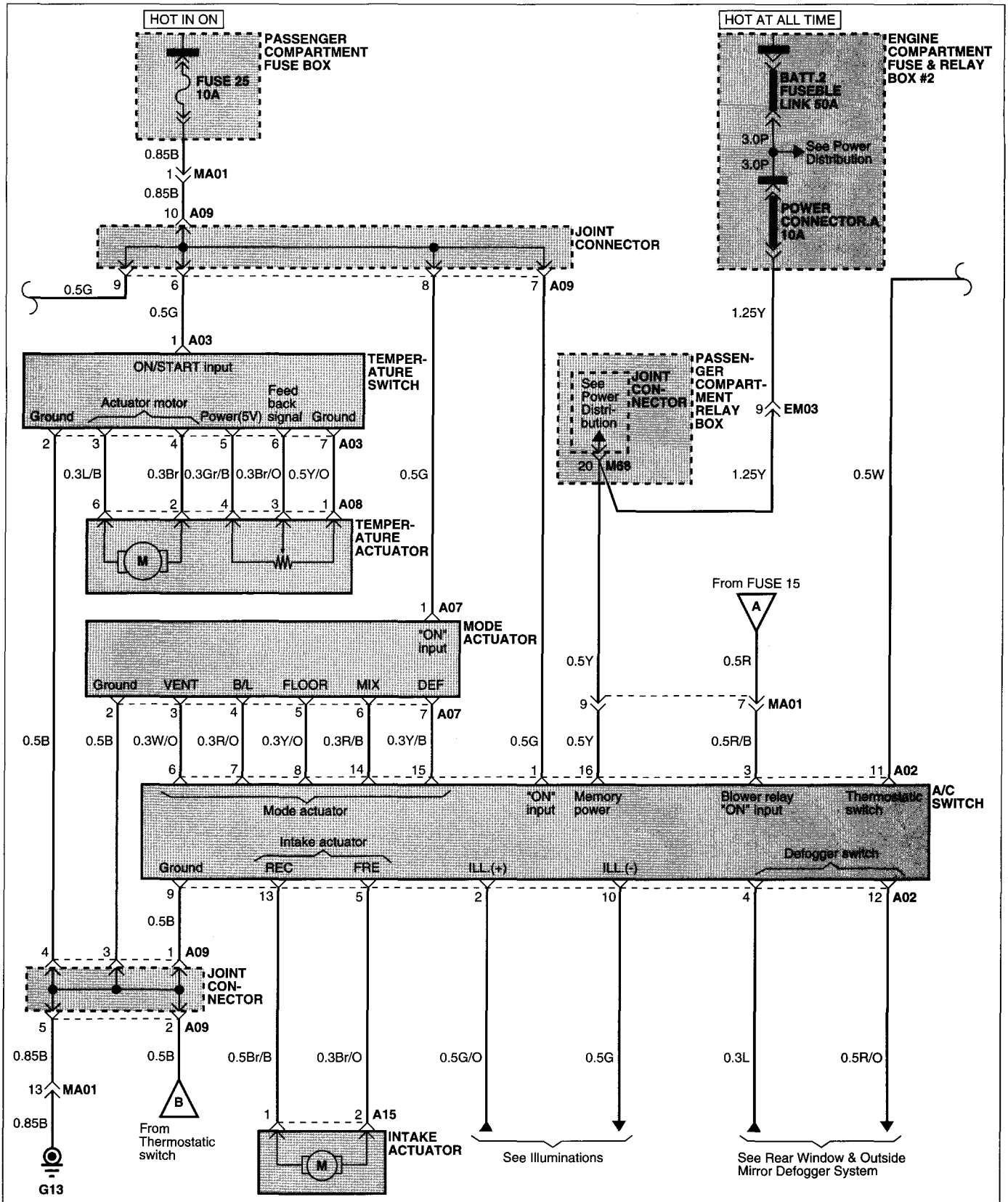

BLOWER & A/C CONTROL (MANUAL) (3)

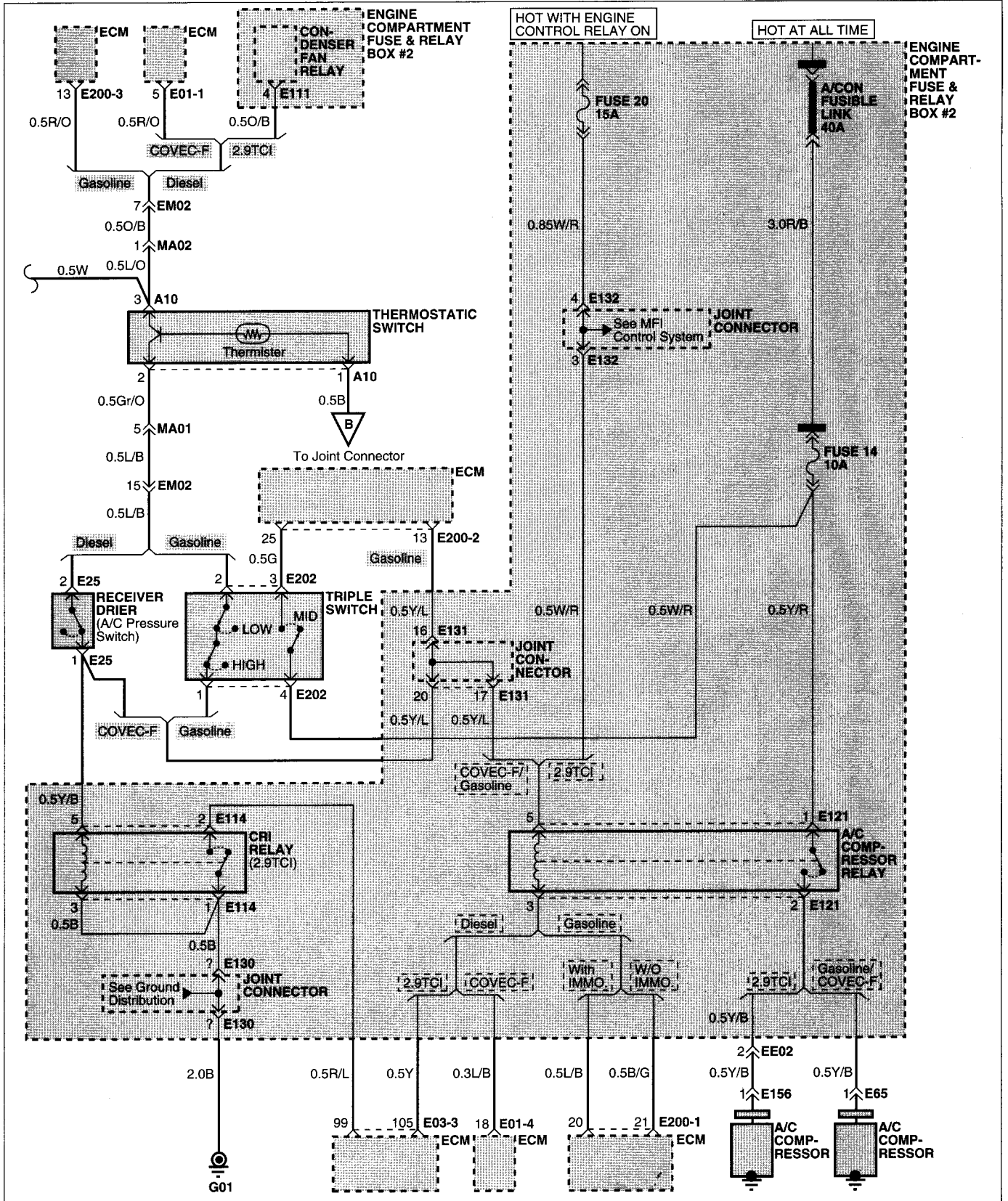

COMPONENT LOCATION INDEX

Components		Location reference - page
A01	Blower switch	CL-27
A02	A/C switch	CL-27
A03	Temperature switch	CL-27
A06	Blower relay	CL-27
A07	Mode actuator	CL-27
A08	Temperature actuator	CL-27
A09	Joint connector	CL-27
A10	Thermostatic switch	CL-27
A13	Blower resistor	CL-27
A15	Intake actuator	CL-27
A16	Blower motor	CL-28
E01-1	ECM (COVEC-F)	CL- 8
E01-4	ECM (COVEC-F)	CL- 8
E03-3	ECM (2.9TCI)	CL- 8
E25	Receiver drier	CL- 9
E65	A/C compressor (Gasoline/COVEC-F)	CL-12
E111	Condenser fan relay	CL-14
E114	CRI relay (2.9TCI)	CL-14
E121	A/C compressor relay	CL-14
E130	Joint connector	CL-14
E131	Joint connector	CL-14
E132	Joint connector	CL-14
E156	A/C compressor (2.9TCI)	CL-15
E200-1	ECM (Gasoline)	CL-16
E200-2	ECM (Gasoline)	CL-16
E200-3	ECM (Gasoline)	CL-16
E202	Triple switch (Gasoline)	CL-16
M68	Joint connector	CL- 5
Connectors		
EE02		CL-18
EM02		CL-19
MA01		CL- 6
MA02		CL- 6
Grounds		
G01		CL-29
G13		CL-29
G14		CL-29

Circuit Description

Blower control

When the ignition switch is in ON and the blower switch is in any position except OFF, the blower relay coil energizes and the blower relay contact closes. Battery voltage is then applied to the blower motor through the closed contacts of the blower relay, and a ground is provided to the blower motor through the blower resistor and blower switch.

As the blower switch is moved from OFF to HI, resistance of the resistors (built-in blower resistor) will be decreased and the battery voltage applied to the blower motor will be increased. This will increase the blower motor speed.

When the blower switch is in HI, all the resistors are bypassed and the maximum voltage is now applied to the blower motor so that it runs at the highest speed.

A/C control

When the ignition switch is in ON and the blower switch is in any position except OFF, the blower relay coil energizes and battery voltage is applied to the A/C switch through the closed contact of the blower relay and fuse 25. With the A/C switch ON, the engine control module (ECM) will ground the coil of the A/C control relay after a short delay to adjust idle speed. Battery voltage will then be applied to the compressor magnetic clutch from the A/C fuse through the closed contacts of the A/C relay. The A/C compressor then runs.

MFI CONTROL SYSTEM (COVEC-F)

MFI CONTROL SYSTEM (COVEC-F)

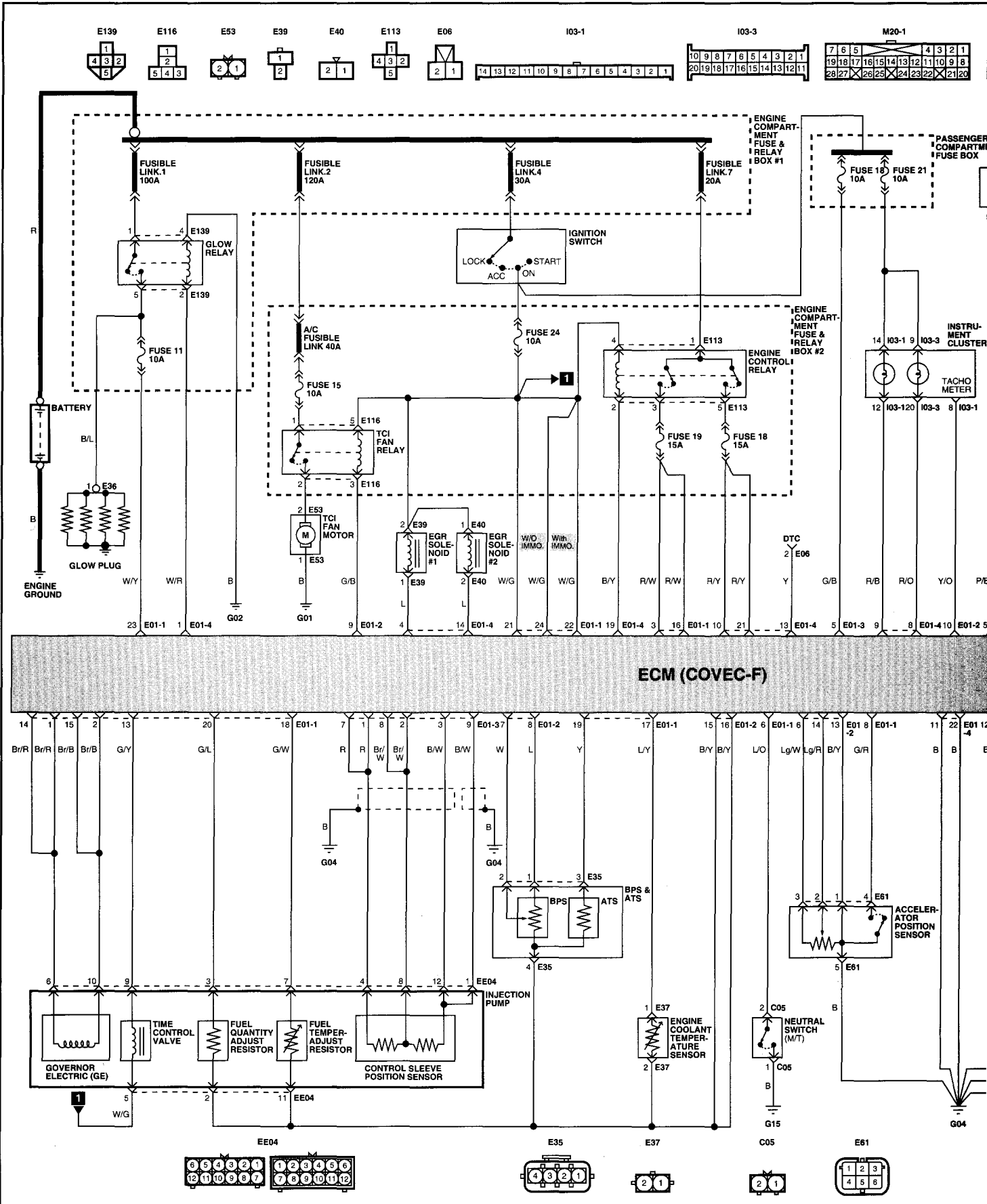

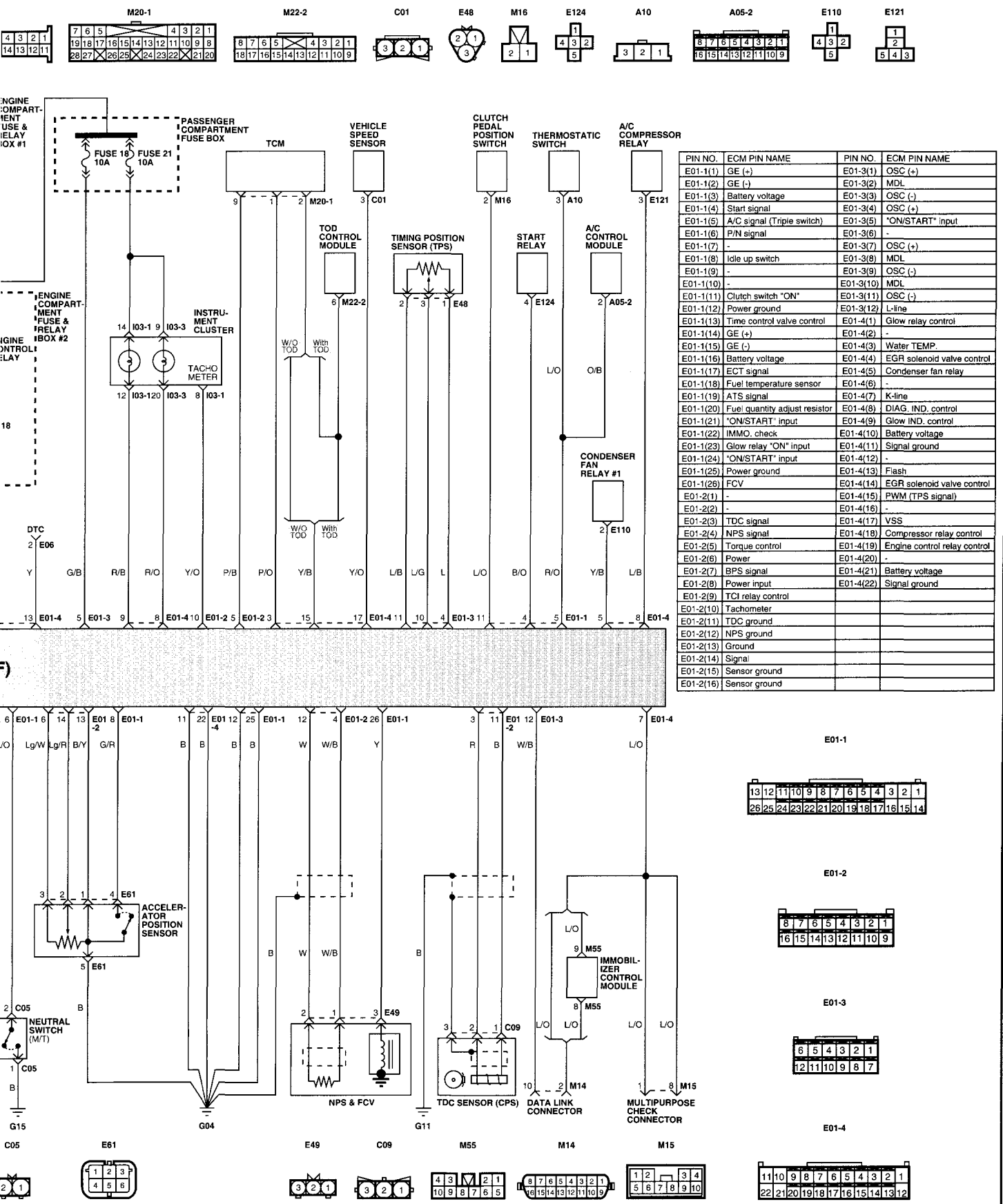

MFI CONTROL SYSTEM (2.9TCI)

MFI CONTROL SYSTEM (2.9TCI)

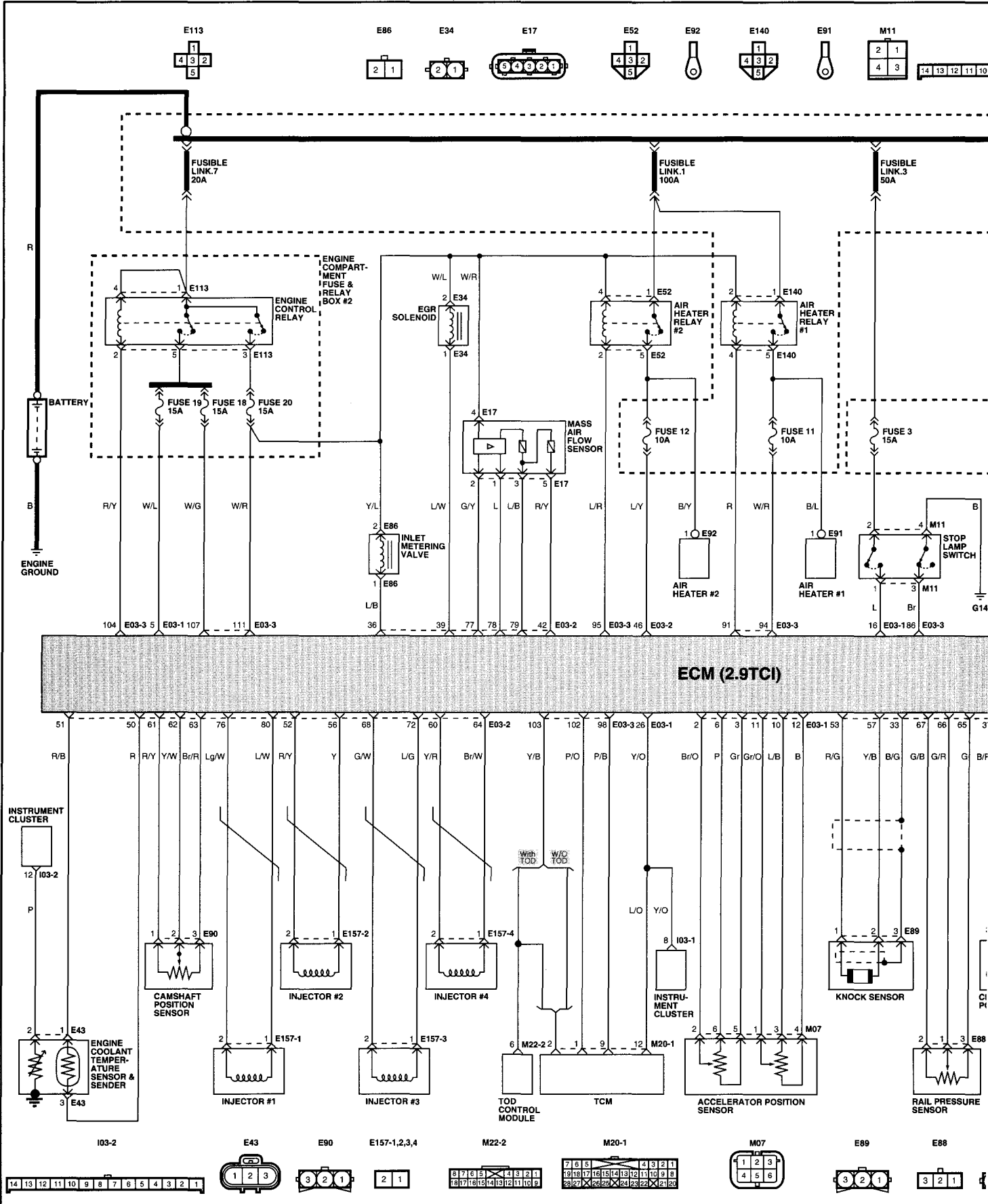

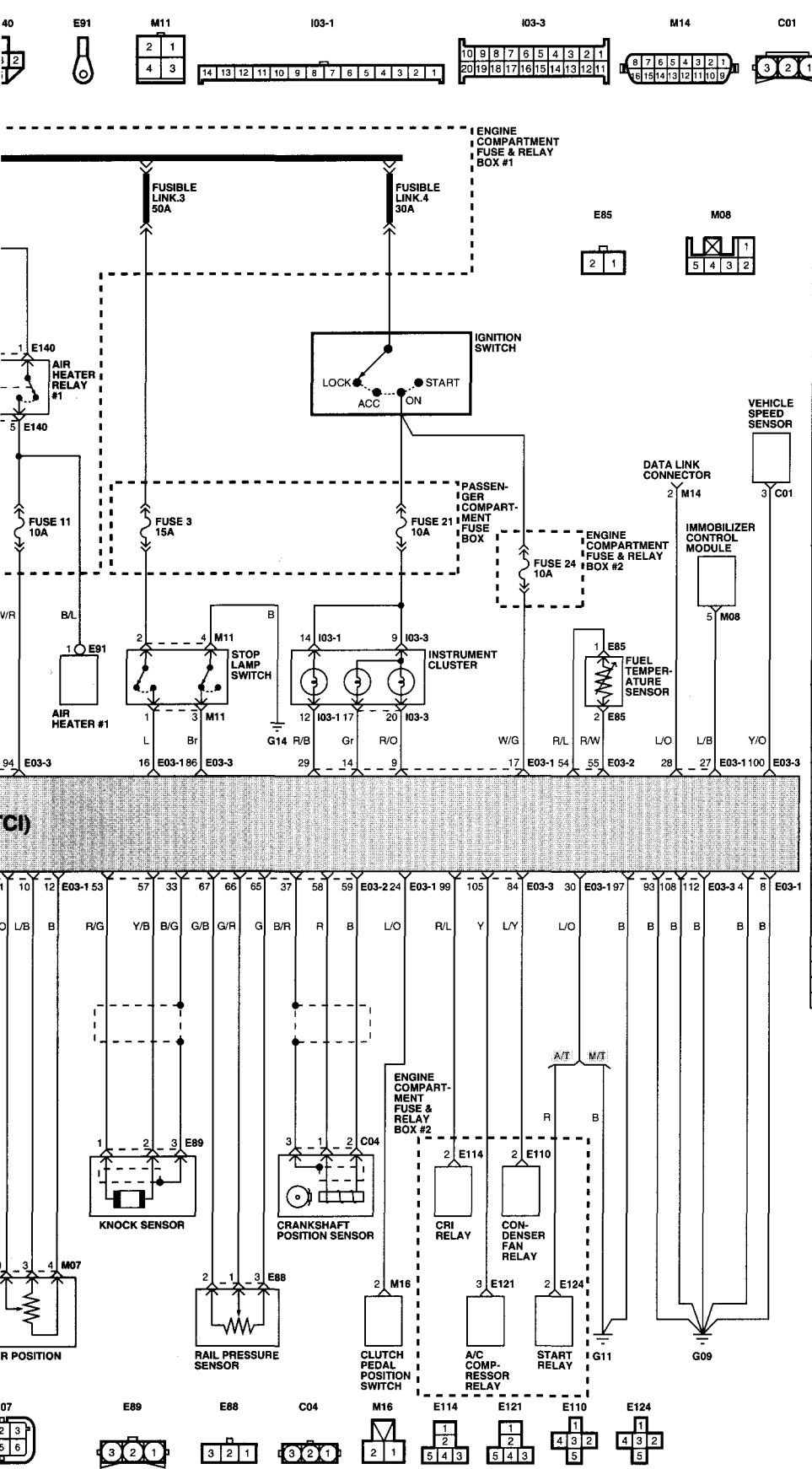

PIN NO.	ECM PIN NAME	PIN NO.	ECM PIN NAME
E03-1(1)	-	E03-2(57)	Knock sensor
E03-1(2)	POS.1	E03-2(58)	CPS sensor
E03-1(3)	GND.1	E03-2(59)	CPS sensor
E03-1(4)	Ground	E03-2(60)	Injector control #4
E03-1(5)	Battery voltage	E03-2(61)	Power
E03-1(6)	Vref.1	E03-2(62)	Signal
E03-1(7)	-	E03-2(63)	Ground
E03-1(8)	Ground	E03-2(64)	Injector control #4
E03-1(9)	IND. control	E03-2(65)	Power
E03-1(10)	Vref.2	E03-2(66)	Signal
E03-1(11)	POS.2	E03-2(67)	Ground
E03-1(12)	GND.2	E03-2(68)	Injector control #3
E03-1(13)	-	E03-2(69)	-
E03-1(14)	IND. control	E03-2(70)	-
E03-1(15)	-	E03-2(71)	-
E03-1(16)	Brake signal(Normal)	E03-2(72)	Injector control #3
E03-1(17)	ON/START input	E03-2(73)	-
E03-1(18)	-	E03-2(74)	-
E03-1(19)	-	E03-2(75)	-
E03-1(20)	-	E03-2(76)	Injector control #1
E03-1(21)	-	E03-2(77)	Power
E03-1(22)	-	E03-2(78)	Signal
E03-1(23)	-	E03-2(79)	Ground
E03-1(24)	Clutch switch "ON"	E03-2(80)	Injector control #1
E03-1(25)	-	E03-3(81)	-
E03-1(26)	RPM	E03-3(82)	-
E03-1(27)	IMMO. control	E03-3(83)	-
E03-1(28)	K-line	E03-3(84)	Condenser fan relay
E03-1(29)	IND. control	E03-3(85)	-
E03-1(30)	A/T:P/N switch,M/T Ground	E03-3(86)	Radudent brake switch
E03-1(31)	-	E03-3(87)	-
E03-1(32)	-	E03-3(88)	-
E03-2(33)	Knock sensor shield	E03-3(89)	-
E03-2(34)	-	E03-3(90)	-
E03-2(35)	-	E03-3(91)	Air heater relay #1 control
E03-2(36)	I/M valve control	E03-3(92)	-
E03-2(37)	CPS shield	E03-3(93)	Ground
E03-2(38)	-	E03-3(94)	Air heater relay #1 "ON" input
E03-2(39)	EGR solenoid	E03-3(95)	Air heater relay #2 control
E03-2(40)	-	E03-3(96)	-
E03-2(41)	-	E03-3(97)	A/T: Ground, M/T: Open
E03-2(42)	Air temperature sensor	E03-3(98)	Torque
E03-2(43)	-	E03-3(99)	A/C "ON" input
E03-2(44)	-	E03-3(100)	Vehicle speed sensor
E03-2(45)	-	E03-3(101)	-
E03-2(46)	Air heater relay #2 "ON" input	E03-3(102)	Water TEMP
E03-2(47)	-	E03-3(103)	TPS
E03-2(48)	-	E03-3(104)	Engine control relay control
E03-2(49)	-	E03-3(105)	A/C compressor relay control
E03-2(50)	ECT sensor	E03-3(106)	-
E03-2(51)	ECT sensor	E03-3(107)	Battery voltage
E03-2(52)	Injector control #2	E03-3(108)	Ground
E03-2(53)	Knock sensor	E03-3(109)	-
E03-2(54)	Fuel temperature sensor	E03-3(110)	-
E03-2(55)	Fuel temperature sensor	E03-3(111)	Battery voltage
E03-2(56)	Injector control #2	E03-3(112)	Ground

E03-1

1	5	9	13	17	21	25	29
2	6	10	14	18	22	26	30
3	7	11	15	19	23	27	31
4	8	12	16	20	24	28	32

E03-2

33	37	41	45	49	53	57	61	65	69	73	77
34	38	42	46	50	54	58	62	66	70	74	78
35	39	43	47	51	55	59	63	67	71	75	79
36	40	44	48	52	56	60	64	68	72	76	80

E03-3

81	85	89	93	97	101	105	109
82	86	90	94	98	102	106	110
83	87	91	95	99	103	107	111
84	88	92	96	100	104	108	112

MFI CONTROL SYSTEM (GASOLINE)

MFI CONTROL SYSTEM (GASOLINE)

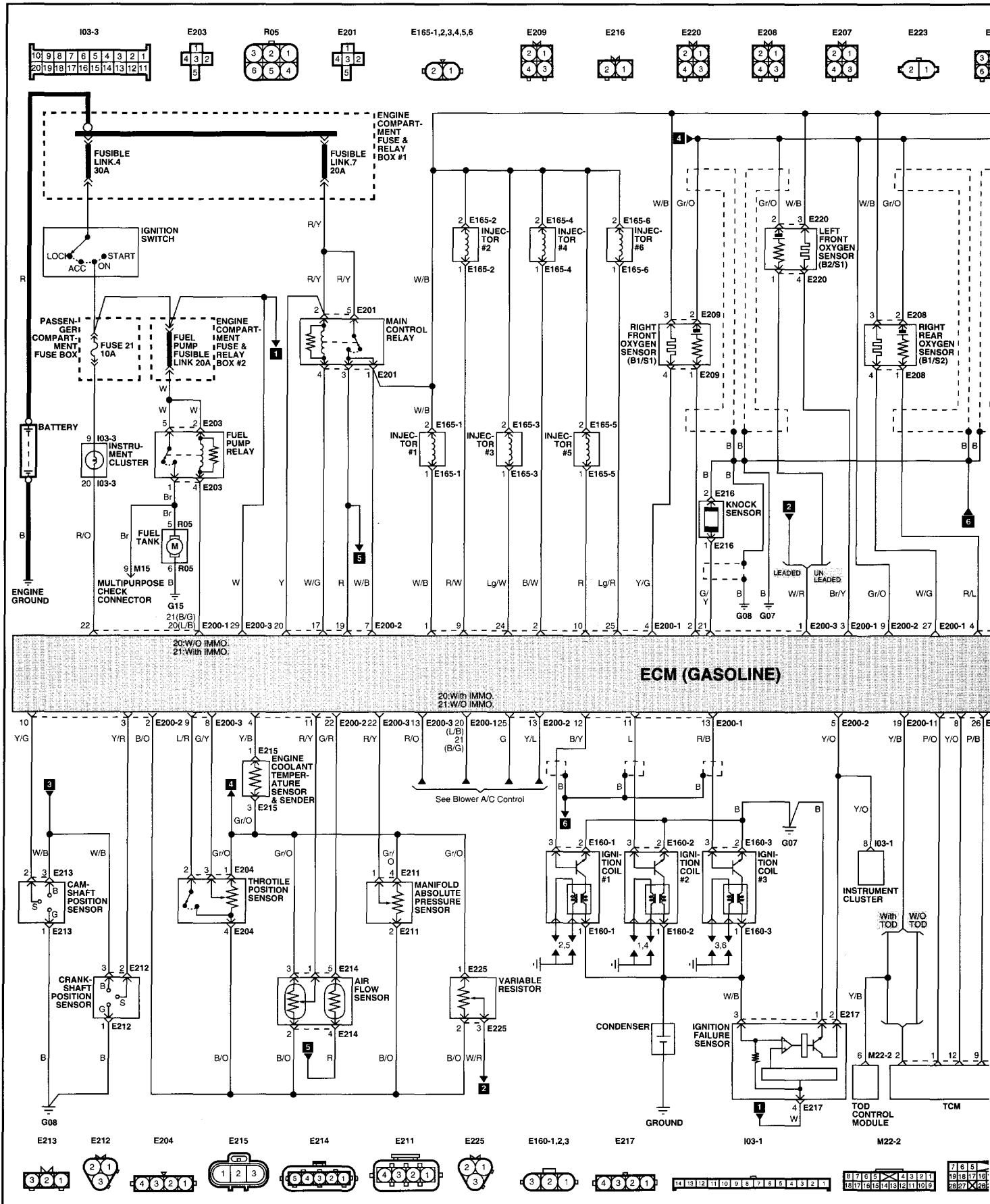

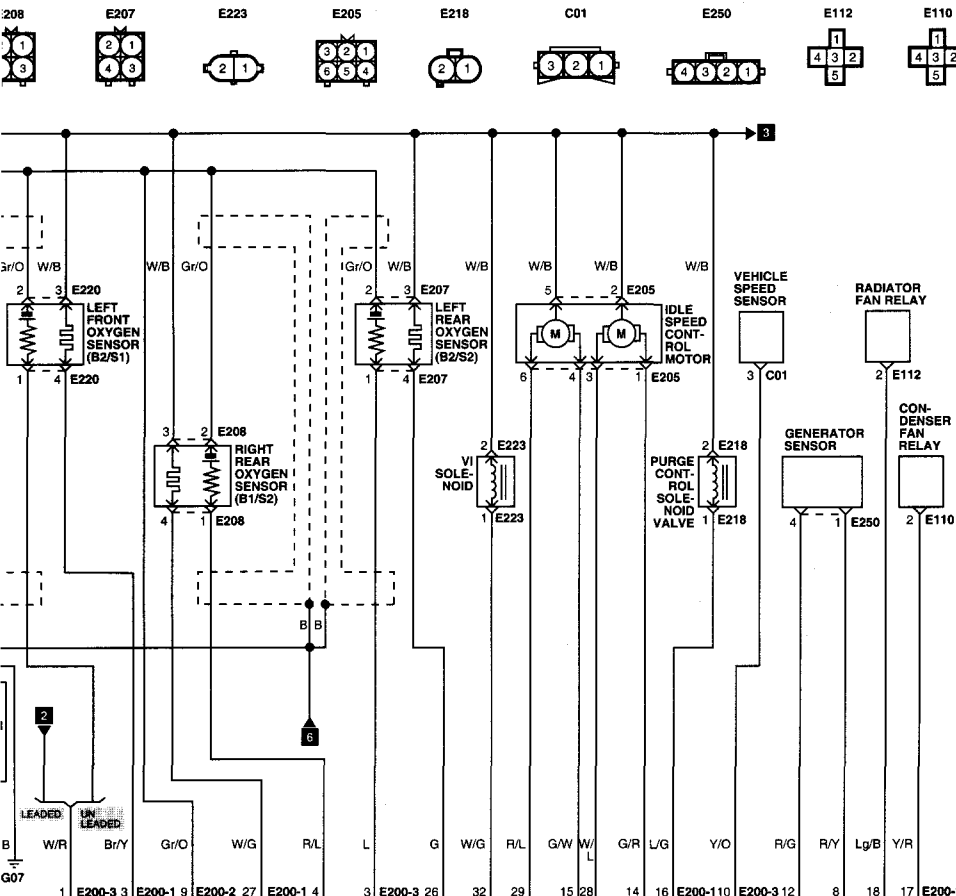

PIN NO.	ECM PIN NAME	PIN NO.	ECM PIN NAME
E200-1(1)	INJ #1	E200-2(13)	A/C PRESS SW (H/L/O)
E200-1(2)	INJ #4	E200-2(14)	P/S SW
E200-1(3)	02 SNS HEATER FL NOTE5	E200-2(15)	-
E200-1(4)	02 SNS HEATER FR NOTE5	E200-2(16)	-
E200-1(5)	-	E200-2(17)	CONTROL RELAY
E200-1(6)	-	E200-2(18)	POWER GROUND
E200-1(7)	-	E200-2(19)	BATTERY
E200-1(8)	ALT G TERM	E200-2(20)	BATTERY (BACK UP)
E200-1(9)	INJ #2	E200-2(21)	-
E200-1(10)	INJ #5	E200-2(22)	AIR TEMP SNS (A,T,S)
E200-1(11)	IG COIL #1/#4	E200-2(23)	-
E200-1(12)	IG COIL #2/#5	E200-2(24)	-
E200-1(13)	IG COIL #3/#6	E200-2(25)	A/C PRESS SW (MIDDLE)
E200-1(14)	ISC STM A	E200-2(26)	TORQUE CONTROL
E200-1(15)	ISC STM C	E200-2(27)	N SW
E200-1(16)	PURGE SOL (PWM)	E200-2(28)	ST SIG
E200-1(17)	FAN RELAY HI (RADIATOR)	E200-3(1)	02 SNS FL
E200-1(18)	FAN RELAY LO	E200-3(2)	02 SNS FR
E200-1(19)	TPS PWM	E200-3(3)	02 SNS RL
E200-1(20)	FUEL PUMP RELAY	E200-3(4)	02 SNS RR
E200-1(21)	A/C RELAY (POWER)	E200-3(5)	MILL REQUEST
E200-1(22)	ENG. CHECK LAMP (MIL)	E200-3(6)	-
E200-1(23)	SPARK TIMING ADJ (+)	E200-3(7)	-
E200-1(24)	INJ #3	E200-3(8)	T.P.S
E200-1(25)	INJ #6	E200-3(9)	IDLE SW (TPS W/)/NOTE4
E200-1(26)	02 SNS HEATER RL	E200-3(10)	VEHICLE SPEED (REED SW)
E200-1(27)	02 SNS HEATER RR	E200-3(11)	-
E200-1(28)	ISC STM B	E200-3(12)	-
E200-1(29)	ISC STM D	E200-3(13)	A/C SW
E200-1(30)	-	E200-3(14)	IGNITION TIME ADJ
E200-1(31)	-	E200-3(15)	DIAGNOSIS K
E200-1(32)	VI SOL	E200-3(16)	-
E200-1(33)	-	E200-3(17)	-
E200-1(34)	-	E200-3(18)	-
E200-1(35)	-	E200-3(19)	-
E200-2(1)	WATER TEMP SWITCH	E200-3(20)	-
E200-2(2)	SENSOR SOURCE	E200-3(21)	KNOCK SENSOR
E200-2(3)	CAS (SGT) NOTE1	E200-3(22)	MDP SNS
E200-2(4)	WATER TEMP SNS NOTE2	E200-3(23)	-
E200-2(5)	IGN DET. SIG	E200-3(24)	-
E200-2(6)	POWER GROUND	E200-3(25)	-
E200-2(7)	BATTERY	E200-3(26)	-
E200-2(8)	ENGINE RPM	E200-3(27)	-
E200-2(9)	SENSOR GROUND	E200-3(28)	-
E200-2(10)	CPS (SGC)	E200-3(29)	IG SW
E200-2(11)	AFS (HFM5)	E200-3(30)	FLASH POWER
E200-2(12)	ALTR FR SG		

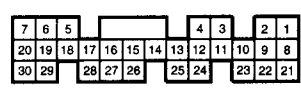
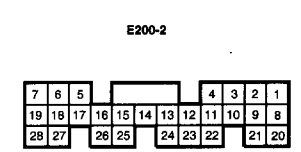
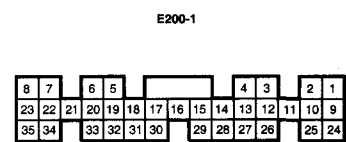
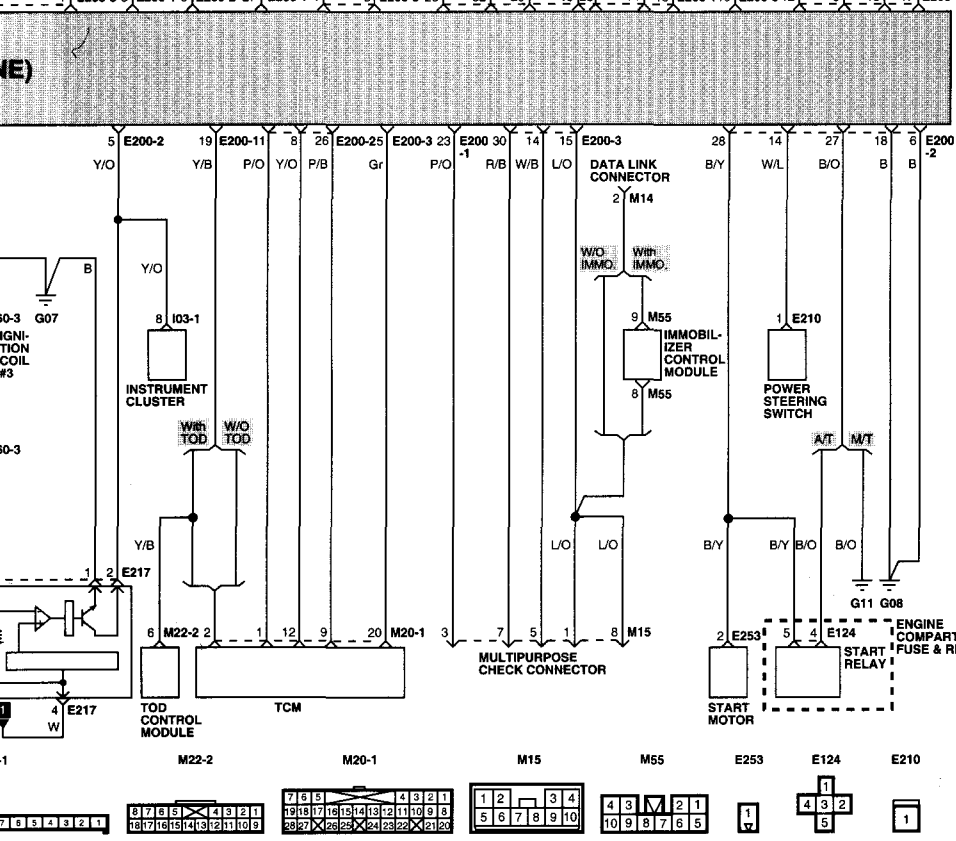

AUTOMATIC TRANSAXLE CONTROL SYSTEM

AUTOMATIC TRANSAXLE CONTROL SYSTEM

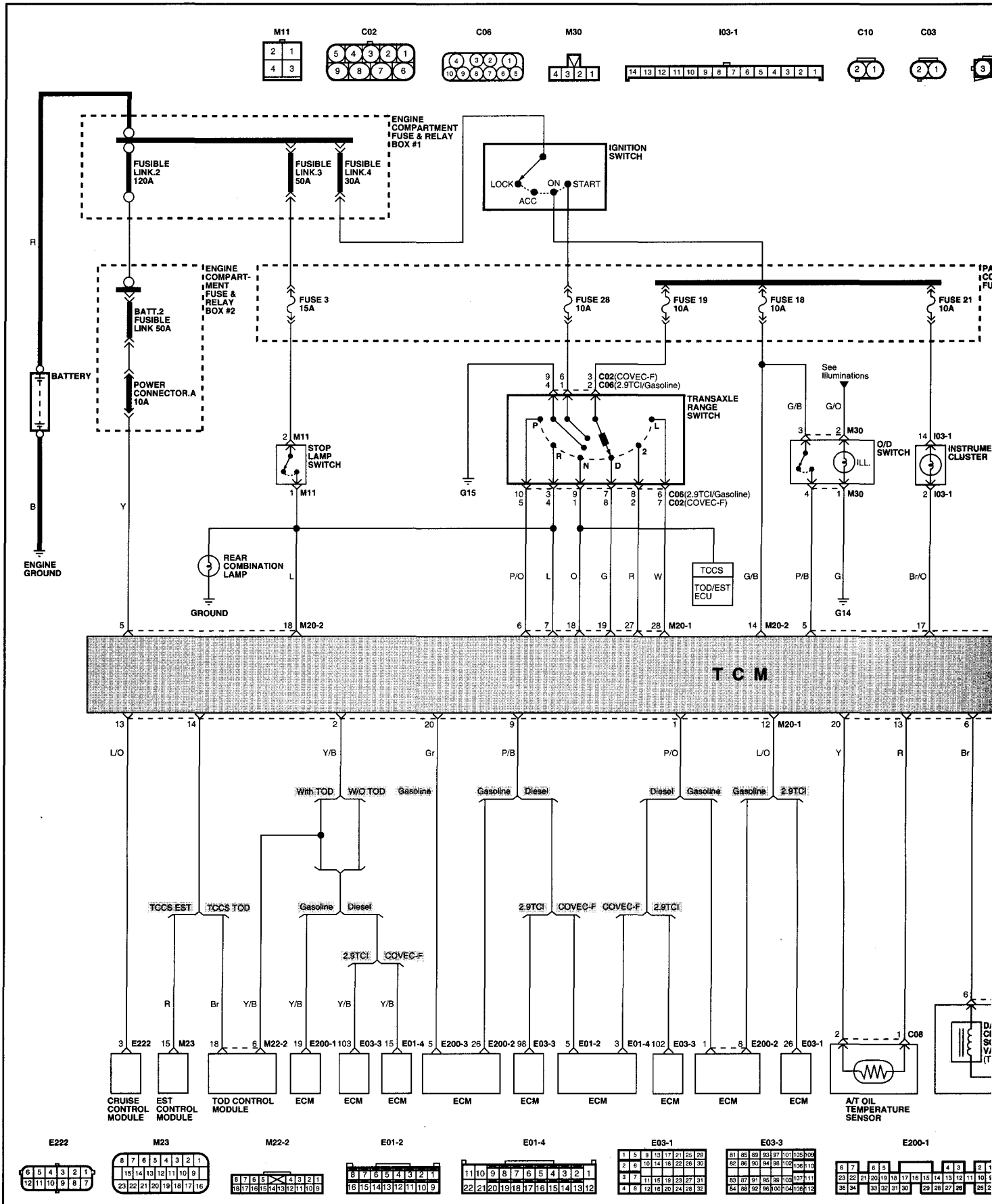

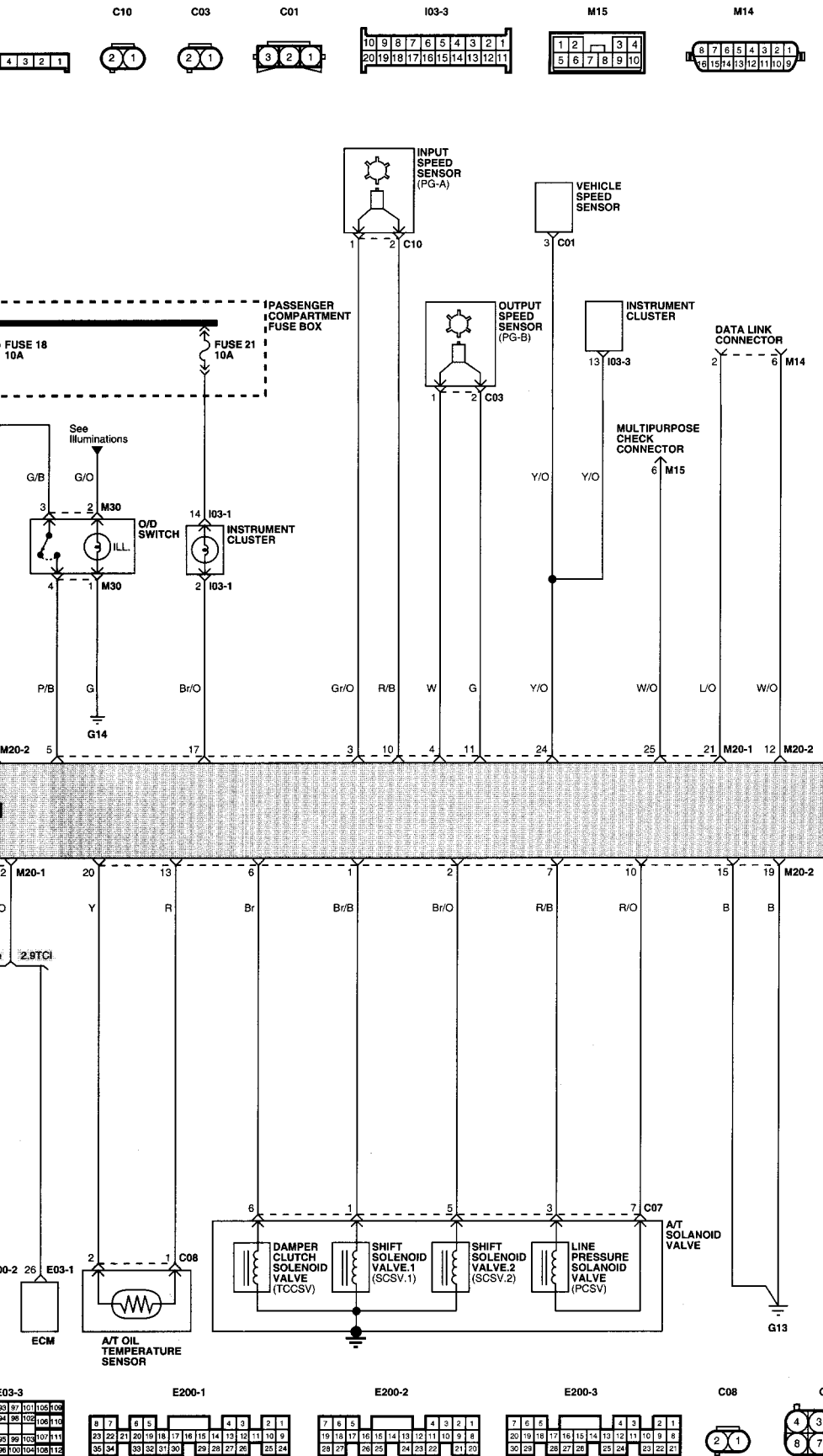

PIN NO.	TCU PIN NAME
M20-1(1)	WATER TEMP SIGNAL
M20-1(2)	TPS SIGNAL (PWM)
M20-1(3)	CO CYLINDER REVOLUTION SENSOR
M20-1(4)	VEHICLE SPEED SENSOR
M20-1(5)	O/D OFF SWITCH
M20-1(6)	INHIBITOR SWITCH (P)
M20-1(7)	INHIBITOR SWITCH (R)
M20-1(8)	NC
M20-1(9)	SEE TABLE
M20-1(10)	EARTH FOR CO REVOLUTION SENSOR
M20-1(11)	EARTH FOR VEHICLE SPEED SENSOR
M20-1(12)	SEE TABLE
M20-1(13)	SEE TABLE
M20-1(14)	SEE TABLE
M20-1(15)	NC
M20-1(16)	NC
M20-1(17)	OTS LAMP
M20-1(18)	INHIBITOR SWITCH (N)
M20-1(19)	INHIBITOR SWITCH (D)
M20-1(20)	SEE TABLE
M20-1(21)	K-LINE
M20-1(22)	NC
M20-1(23)	NC
M20-1(24)	SEE TABLE
M20-1(25)	DIAGNOSIS SW.
M20-1(26)	NC
M20-1(27)	INHIBITOR SWITCH (2)
M20-1(28)	INHIBITOR SWITCH (L)
M20-2(1)	SHIFT CONTROL SOLENOID 1
M20-2(2)	SHIFT CONTROL SOLENOID 2
M20-2(3)	NC
M20-2(4)	SEE TABLE
M20-2(5)	BATTERY
M20-2(6)	LOCK-UP CONTROL SOLENOID
M20-2(7)	PRESSURE CONTROL SOLENOID
M20-2(8)	NC
M20-2(9)	NC
M20-2(10)	EARTH FOR PRESSURE CONTROL SOLENOID
M20-2(11)	NC
M20-2(12)	DTC CLEAR SW
M20-2(13)	OIL TEMPERATURE SENSOR (OTS)
M20-2(14)	POWER (IG.1)
M20-2(15)	EARTH FOR POWER
M20-2(16)	NC
M20-2(17)	NC
M20-2(18)	BRAKE SWITCH
M20-2(19)	EARTH FOR POWER
M20-2(20)	EARTH FOR OIL TEMPERATURE SENSOR

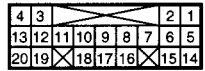
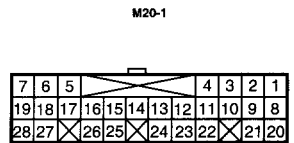

CONNECTOR CONFIGURATIONS





A/C & A/BAG HARNESS	CC-25
DOOR HARNESS	CC-20
FRONT HARNESS	CC-9
INSTRUMENT HARNESS	CC-18
MAIN HARNESS	CC-2
REAR HARNESS	CC-22
T/M HARNESS	CC-19

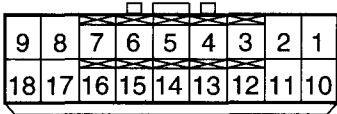
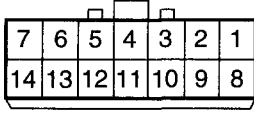

MAIN HARNESS

EFA43C7B

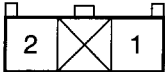
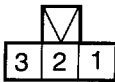
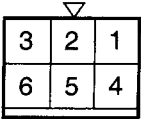
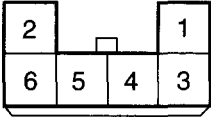
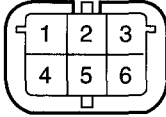
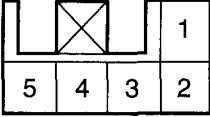
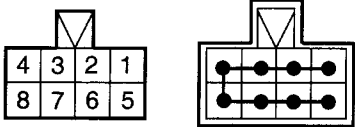
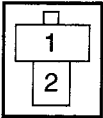
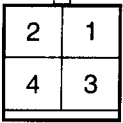
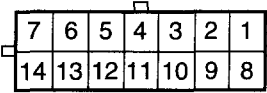
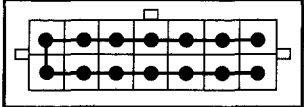
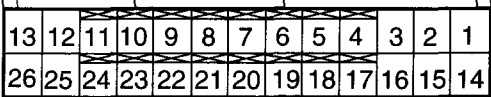
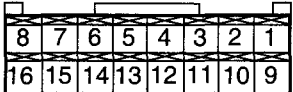
MAIN HARNESS (1)

<p style="text-align: center;">M01-1</p>  <p style="text-align: right; font-size: small;">CR18F007</p>	<p style="text-align: center;">M01-2</p>  <p style="text-align: right; font-size: small;">CR14F010</p>	<p style="text-align: center;">M01-3</p>  <p style="text-align: right; font-size: small;">CR04F037</p>	
<p style="text-align: center;">M02</p>  <p style="text-align: right; font-size: small;">CR02F072</p>	<p style="text-align: center;">BLANK</p>	<p style="text-align: center;">M04</p>  <p style="text-align: right; font-size: small;">CR03F007</p>	<p style="text-align: center;">M05</p>  <p style="text-align: right; font-size: small;">CR06F037</p>
<p style="text-align: center;">M06</p>  <p style="text-align: right; font-size: small;">CR06F017</p>	<p style="text-align: center;">M07</p>  <p style="text-align: right; font-size: small;">CR06M011</p>	<p style="text-align: center;">M08</p>  <p style="text-align: right; font-size: small;">CR05F013</p>	<p style="text-align: center;">BLANK</p>
<p style="text-align: center;">M09</p>  <p style="text-align: right; font-size: small;">CR08F039</p>		<p style="text-align: center;">M10</p>  <p style="text-align: right; font-size: small;">CR02M006</p>	<p style="text-align: center;">M11</p>  <p style="text-align: right; font-size: small;">CR04F016</p>
<p style="text-align: center;">M12</p>   <p style="text-align: right; font-size: small;">CR14F022</p>		<p style="text-align: center;">M13-1</p>  <p style="text-align: right; font-size: small;">CR26F006</p>	
<p style="text-align: center;">M13-2</p>  <p style="text-align: right; font-size: small;">CR16F016</p>		<p style="text-align: center;">M14</p>  <p style="text-align: right; font-size: small;">CR16F022</p>	



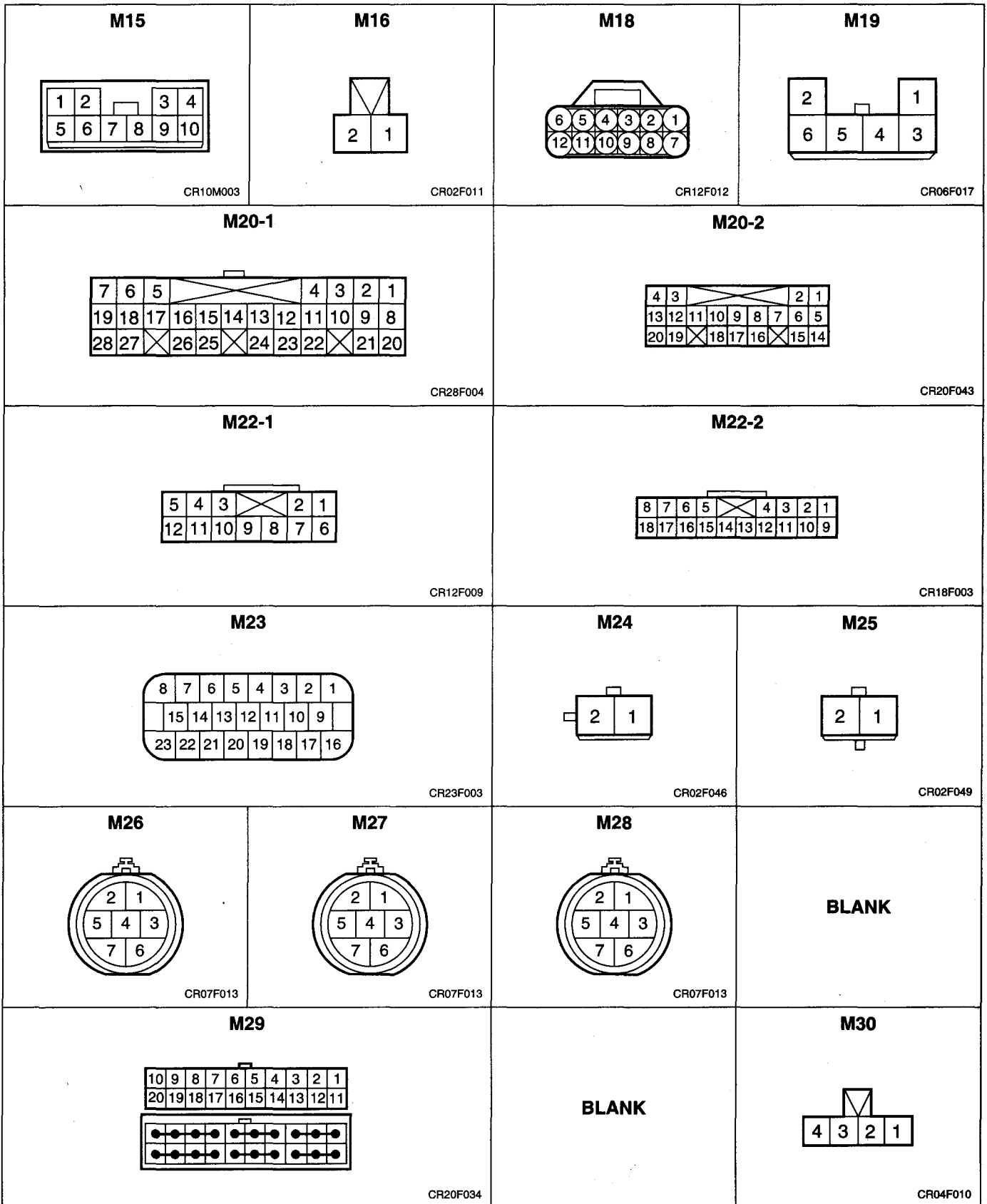

MAIN HARNESS (2)





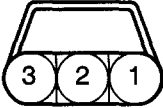
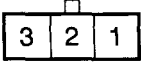
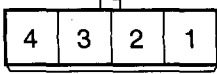

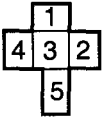
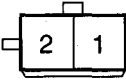
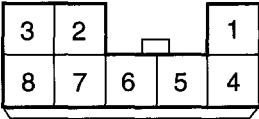
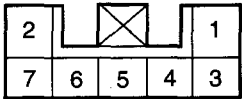
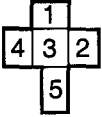
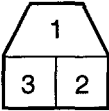
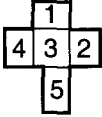
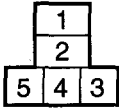
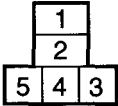
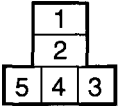
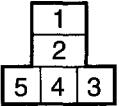
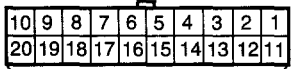
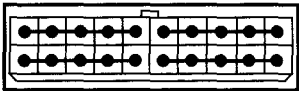
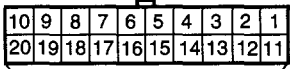
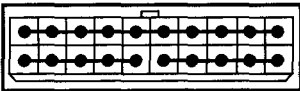
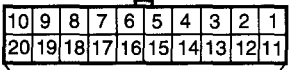
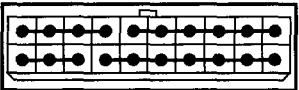
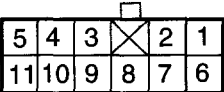
MAIN HARNESS (3)

<p>M31</p> <p>CR14F023</p>		<p>M32</p> <p>CR06F003</p>	<p>M33</p> <p>CR10F009</p>
<p>M34</p> <p>CR03F085</p>	<p>M35</p> <p>CR02F046</p>	<p>M36</p> <p>CR05F013</p>	<p>M37</p> <p>CR08F029</p>
<p>M38</p> <p>CR26F002</p>		<p>M40</p> <p>CR16F014</p>	
<p>M41</p> <p>CR03F004</p>	<p>M42</p> <p>CR04F001</p>	<p>M43</p> <p>CR01F004</p>	<p>BLANK</p>
<p>M45</p> <p>CR08F038</p>		<p>M46</p> <p>CR02F064</p>	<p>M47</p> <p>CR10F009</p>
<p>M48</p> <p>CR10F009</p>	<p>M49</p> <p>CR06F017</p>	<p>M50</p> <p>CR06F017</p>	<p>BLANK</p>

MAIN HARNESS (4)

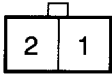
<p>M52</p>  <p>CR03F070</p>	<p>M53</p>  <p>CR03F040</p>	<p>M54</p>  <p>CR04F062</p>	<p>M55</p>  <p>CR10F003</p>
<p>M56</p>  <p>CR05F029</p>	<p>M57</p>  <p>CR02F046</p>	<p>M58</p>  <p>CR08F010</p>	<p>M60</p>  <p>CR07F005</p>
<p>M61</p>  <p>CR05F029</p>	<p>M62</p>  <p>CR03F034</p>	<p>M63</p>  <p>CR05F029</p>	<p>M64</p>  <p>CR05F011</p>
<p>M65</p>  <p>CR05F011</p>	<p>M66</p>  <p>CR05F011</p>	<p>M67</p>  <p>CR05F011</p>	<p>BLANK</p>
<p>M68</p>   <p>CR20F038</p>		<p>M69</p>   <p>CR20F039</p>	
<p>M70</p>   <p>CR20F040</p>		<p>M71</p>  <p>CR11F002</p>	<p>M72</p>  <p>CR02F012</p>

MAIN HARNESS (5)

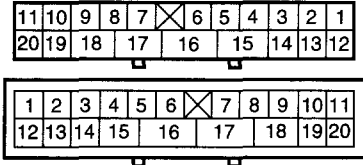
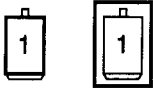
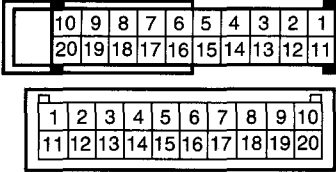
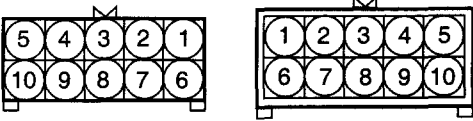
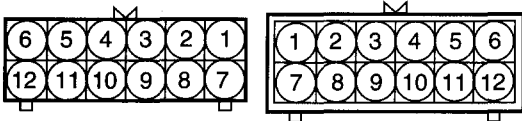
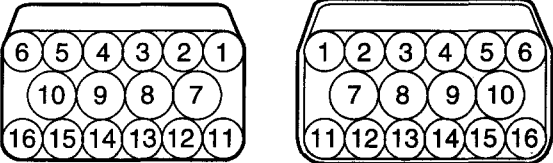
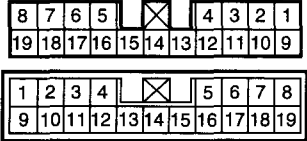
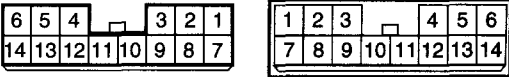
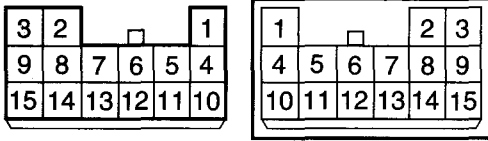
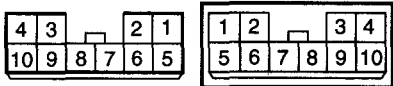
<p>M73</p>  <p>CR02F076</p>	<p>M74</p>  <p>CR02F012</p>	<p>M75</p>  <p>CR02F012</p>	<p>M76</p>  <p>CR02F012</p>
<p>MA01</p>  <p>CR20B019</p>		<p>BLANK</p>	<p>MA02</p>  <p>CR01B005</p>
<p>MA03</p>  <p>CR20B020</p>	<p>MC01</p>  <p>CR10B008</p>		
<p>MC02</p>  <p>CR12B005</p>	<p>MC03</p>  <p>CR16B002</p>		
<p>MD01</p>  <p>CR19B001</p>	<p>MD02</p>  <p>CR14B011</p>		
<p>MD03</p>  <p>CR15B002</p>	<p>MD04</p>  <p>CR10B006</p>		

MAIN HARNESS (6)

MI01

11	10									2	1
22	21	9	8	7	6	5	4	3		13	12
32	31	30	29	28		27	26	25		24	23

1	2									10	11
12	13	3	4	5	6	7	8	9		21	22
23	24	25	26	27		28	29	30		31	32

CR32B002

MI02

4	3			2	1
10	9	8	7	6	5

1	2			3	4
5	6	7	8	9	10

CR10B006

BLANK

BLANK

MI03

10	9	8	7	6		5	4	3	2	1	
22	21	20	19	18	17	16	15	14	13	12	11

1	2	3	4	5		6	7	8	9	10	
11	12	13	14	15	16	17	18	19	20	21	22

CR22B006

BLANK

MM01

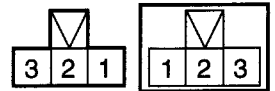

CR09B001

MR01

11	10									2	1
22	21	9	8	7	6	5	4	3		13	12
32	31	30	29	28		27	26	25		24	23

1	2									10	11
12	13	3	4	5	6	7	8	9		21	22
23	24	25	26	27		28	29	30		31	32

CR32B002

MR02

3	2				1
9	8	7	6	5	4
15	14	13	12	11	10

1				2	3
4	5	6	7	8	9
10	11	12	13	14	15

CR15B002

BLANK

BLANK

MR03

11	10									2	1
22	21	9	8	7	6	5	4	3		13	12
32	31	30	29	28		27	26	25		24	23

1	2									10	11
12	13	3	4	5	6	7	8	9		21	22
23	24	25	26	27		28	29	30		31	32

CR32B002

MAIN HARNESS (7)

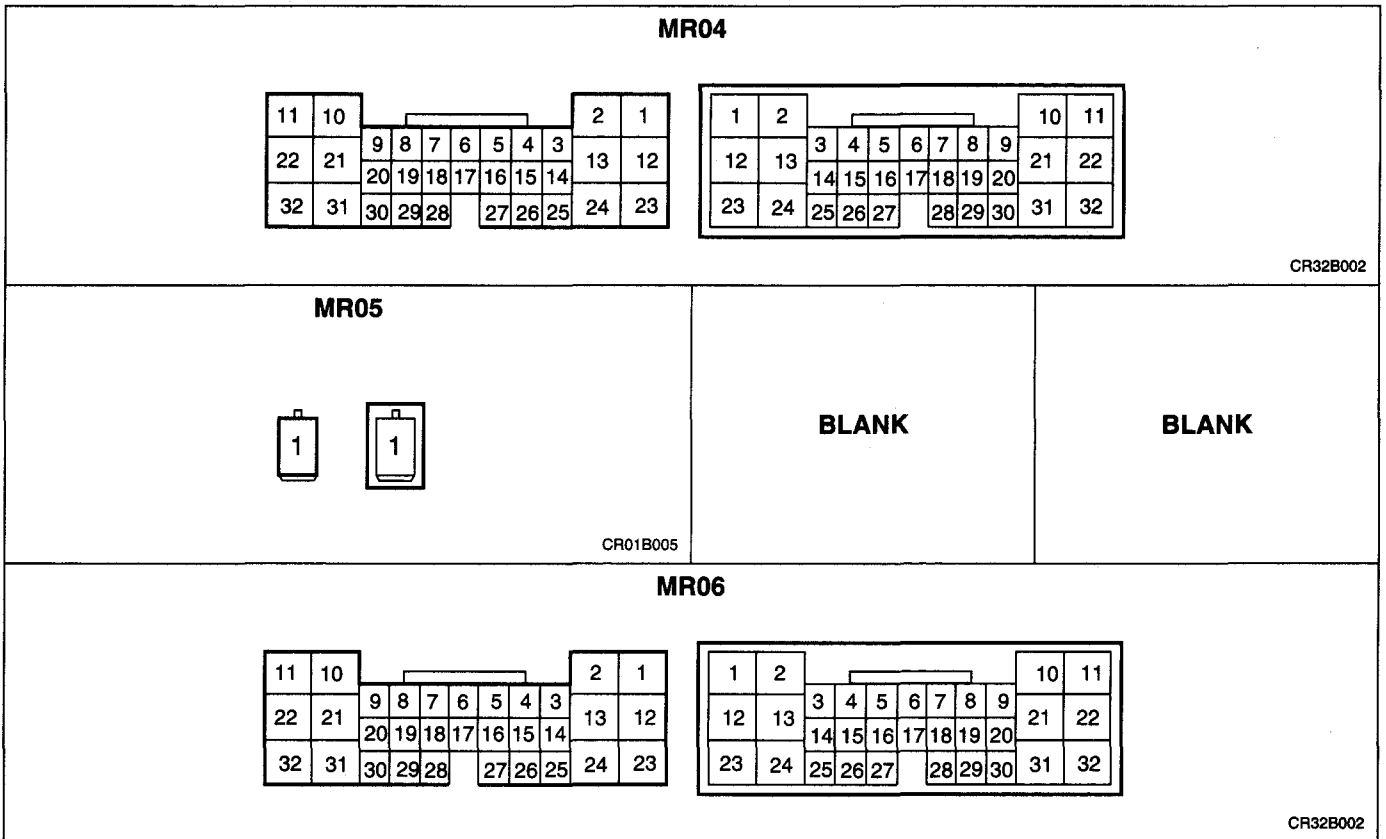





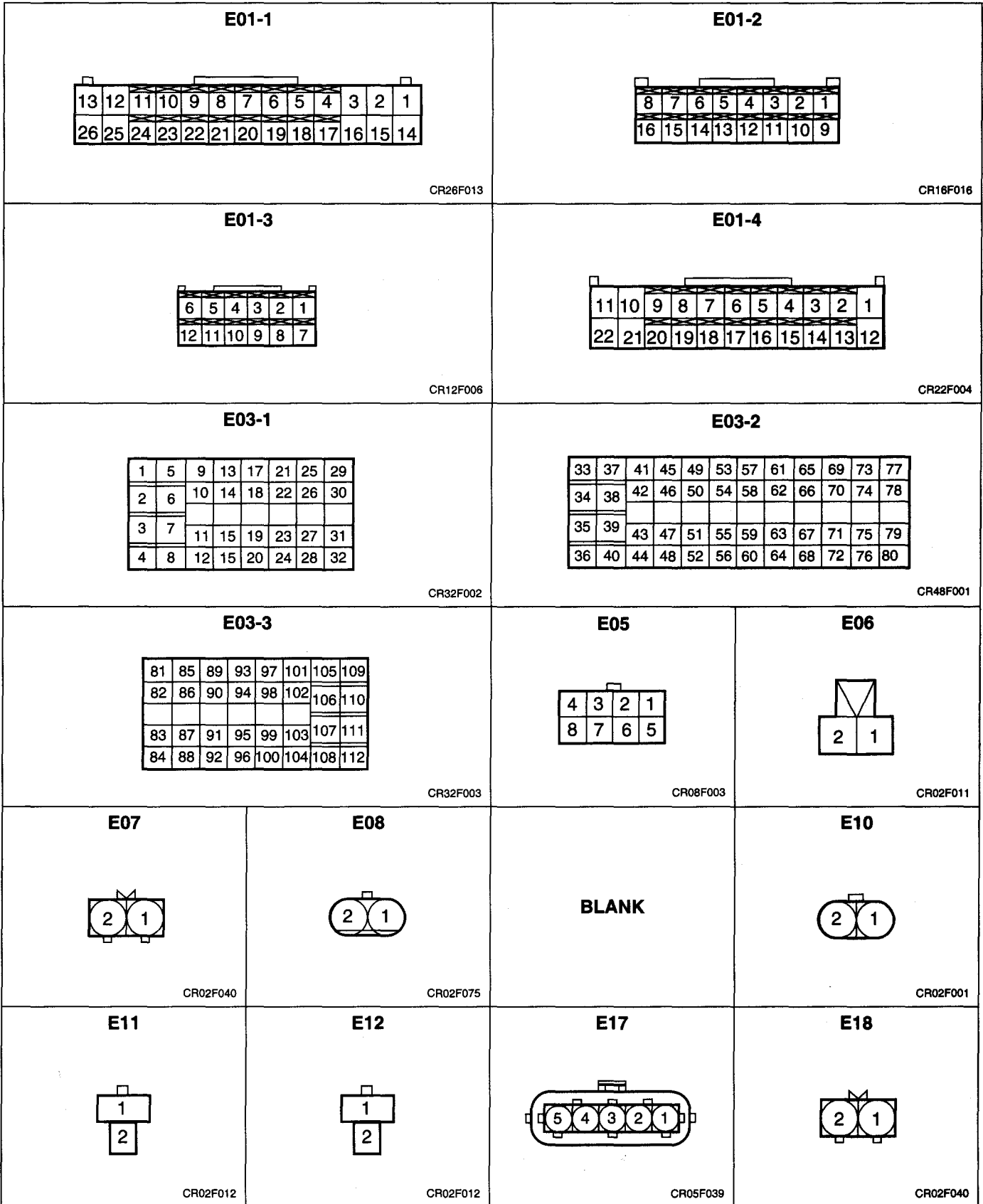

FRONT HARNESS EB3C23D3

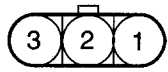
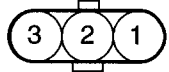
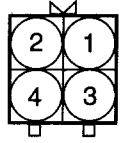
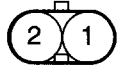
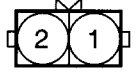
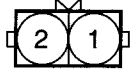
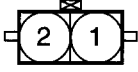
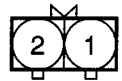
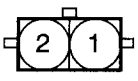
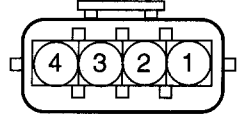

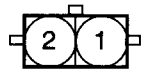

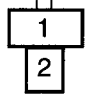
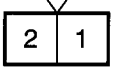
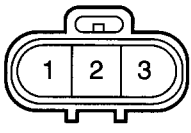
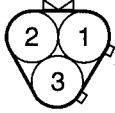
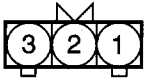

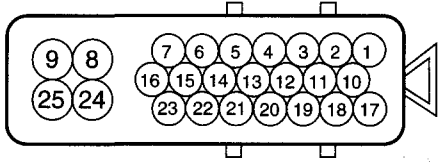
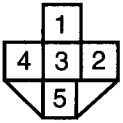
FRONT HARNESS (1)



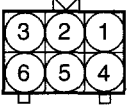

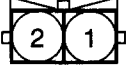
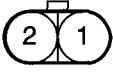
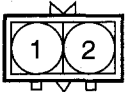
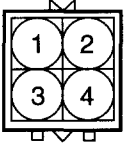
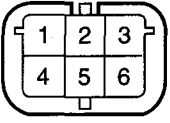
FRONT HARNESS (2)

<p>E19</p>  <p>CR01F020</p>	<p>E21</p>  <p>CR03F016</p>	<p>E22</p>  <p>CR03F001</p>	<p>E23</p>  <p>CR04F027</p>
<p>E25</p>  <p>CR02F014</p>	<p>E29</p>  <p>CR02F018</p>	<p>E30</p>  <p>CR02F018</p>	<p>E32</p>  <p>CR02F091</p>
<p>E33</p>  <p>CR02F040</p>	<p>E34</p>  <p>CR02F009</p>	<p>E35</p>  <p>CR04F054</p>	<p>E36</p>  <p>CR01F002</p>
<p>E37</p>  <p>CR02F009</p>	<p>E38</p>  <p>CR01F006</p>	<p>E39</p>  <p>CR02F012</p>	<p>E40</p>  <p>CR02F035</p>
<p>E43</p>  <p>CR03M015</p>	<p>BLANK</p>	<p>E48</p>  <p>CR03F020</p>	<p>E49</p>  <p>CR03F047</p>
<p>E50</p>  <p>CR01F006</p>	<p>E51</p>  <p>CR25F002</p>		<p>E52</p>  <p>CR05F031</p>

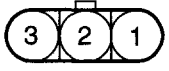
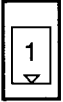
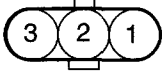
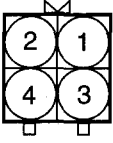
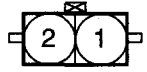
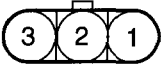
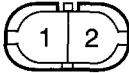
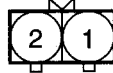
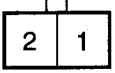
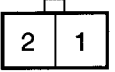
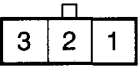
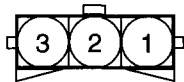
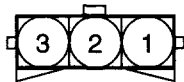



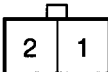
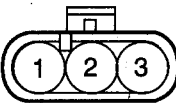
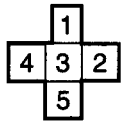
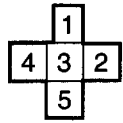
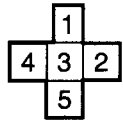
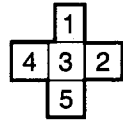
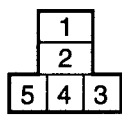
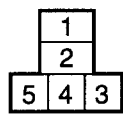
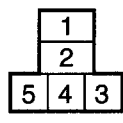
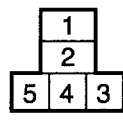
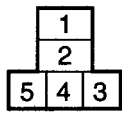
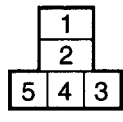
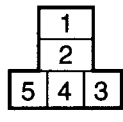
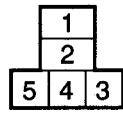
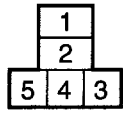
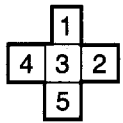
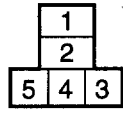
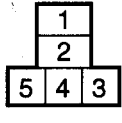
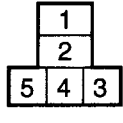
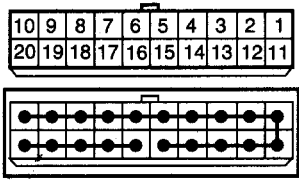

FRONT HARNESS (3)

<p>E53</p>  <p>CR02F040</p>	<p>E54</p>  <p>CR06F016</p>	<p>E55</p>  <p>CR01F031</p>	<p>E56</p>  <p>CR02F041</p>
<p>E57</p>  <p>CR02F001</p>	<p>E59</p>  <p>CR02M017</p>	<p>E60</p>  <p>CR04M008</p>	<p>E61</p>  <p>CR06M011</p>
<p>E63</p>  <p>CR02F040</p>	<p>E64</p>  <p>CR02F040</p>	<p>E65</p>  <p>CR01F038</p>	<p>E69</p>  <p>CR03F016</p>
<p>E70</p>  <p>CR01M005</p>	<p>E71</p>  <p>CR03F001</p>	<p>E72</p>  <p>CR04F027</p>	<p>E74</p>  <p>CR02F091</p>
<p>E75</p>  <p>CR03F016</p>	<p>E76</p>  <p>CR02M007</p>	<p>E77</p>  <p>CR02F040</p>	<p>E85</p>  <p>CR02F076</p>
<p>E86</p>  <p>CR02F076</p>	<p>E88</p>  <p>CR03F040</p>	<p>E89</p>  <p>CR03F029</p>	<p>E90</p>  <p>CR03F029</p>

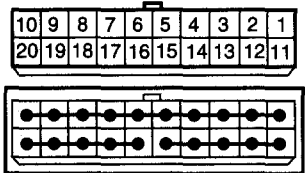
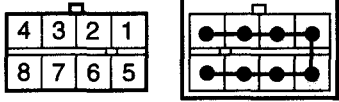
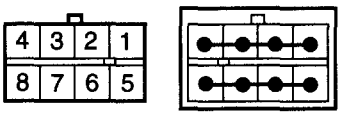
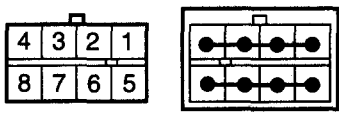
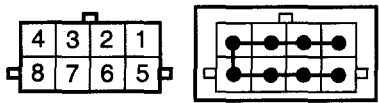
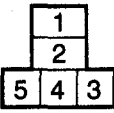
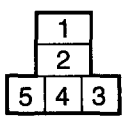
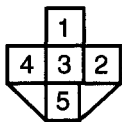
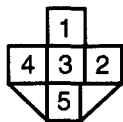

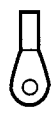
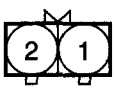
FRONT HARNESS (4)

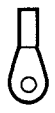
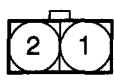
<p>E91</p>  <p>CR01F002</p>	<p>E92</p>  <p>CR01F002</p>	<p>E95</p>  <p>CR02F076</p>	<p>E96</p>  <p>CR03M017</p>
<p>E110</p>  <p>CR05F012</p>	<p>E111</p>  <p>CR05F012</p>	<p>E112</p>  <p>CR05F012</p>	<p>E113</p>  <p>CR05F012</p>
<p>E114</p>  <p>CR05F011</p>	<p>E115</p>  <p>CR05F011</p>	<p>E116</p>  <p>CR05F011</p>	<p>E117</p>  <p>CR05F011</p>
<p>E118</p>  <p>CR05F011</p>	<p>E119</p>  <p>CR05F011</p>	<p>E120</p>  <p>CR05F011</p>	<p>E121</p>  <p>CR05F011</p>
<p>BLANK</p>	<p>E123</p>  <p>CR05F011</p>	<p>E124</p>  <p>CR05F012</p>	<p>E125</p>  <p>CR05F011</p>
<p>E126</p>  <p>CR05F011</p>	<p>E127</p>  <p>CR05F011</p>	<p>E130</p>  <p>CR20F041</p>	





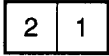
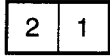
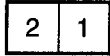
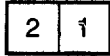
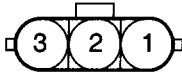
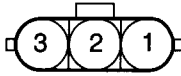
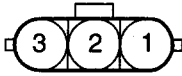
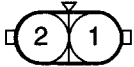
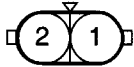
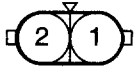
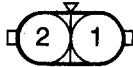
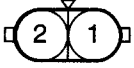
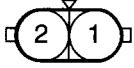
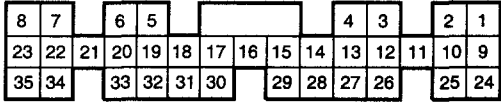
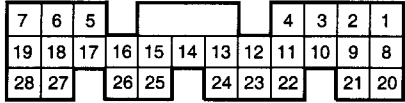

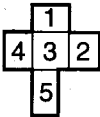
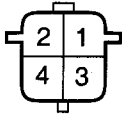
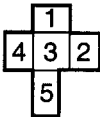
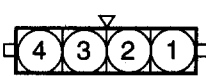
FRONT HARNESS (5)

<p style="text-align: center;">E131</p>  <p style="text-align: right;">CR20F039</p>	<p style="text-align: center;">E132</p>  <p style="text-align: right;">CR08F045</p>		
<p style="text-align: center;">E133</p>  <p style="text-align: right;">CR08F046</p>	<p style="text-align: center;">E134</p>  <p style="text-align: right;">CR08F046</p>		
<p style="text-align: center;">E135</p>  <p style="text-align: right;">CR08F047</p>	<p style="text-align: center;">BLANK</p>	<p style="text-align: center;">E137</p>  <p style="text-align: right;">CR05F011</p>	
<p style="text-align: center;">E138</p>  <p style="text-align: right;">CR05F011</p>	<p style="text-align: center;">E139</p>  <p style="text-align: right;">CR05F031</p>	<p style="text-align: center;">E140</p>  <p style="text-align: right;">CR05F031</p>	<p style="text-align: center;">BLANK</p>
<p style="text-align: center;">E150</p>  <p style="text-align: right;">CR01F002</p>	<p style="text-align: center;">E151</p>  <p style="text-align: right;">CR01F002</p>	<p style="text-align: center;">E152</p>  <p style="text-align: right;">CR02F040</p>	<p style="text-align: center;">E153</p>  <p style="text-align: right;">CR01F006</p>
<p style="text-align: center;">E154</p>  <p style="text-align: right;">CR01F002</p>	<p style="text-align: center;">E155</p>  <p style="text-align: right;">CR02F002</p>	<p style="text-align: center;">BLANK</p>	<p style="text-align: center;">E156</p>  <p style="text-align: right;">CR01F038</p>

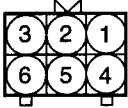
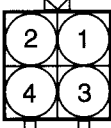
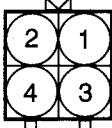
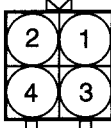

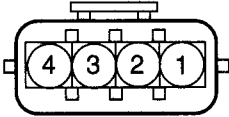
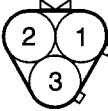

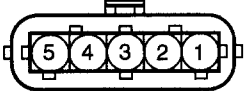
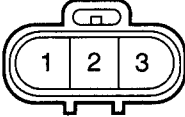
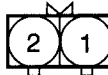
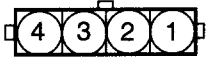
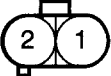
FRONT HARNESS (6)

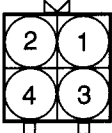
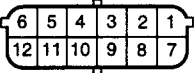
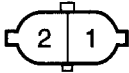
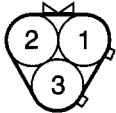
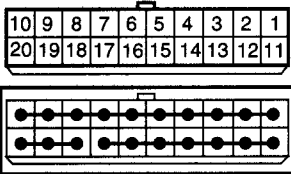
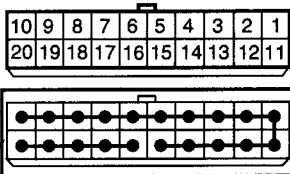
<p>E157-1</p>  <p>CR02F028</p>	<p>E157-2</p>  <p>CR02F028</p>	<p>E157-3</p>  <p>CR02F028</p>	<p>E157-4</p>  <p>CR02F028</p>
<p>E160-1</p>  <p>CR03F036</p>	<p>E160-2</p>  <p>CR03F036</p>	<p>E160-3</p>  <p>CR03F036</p>	<p>BLANK</p>
<p>E165-1</p>  <p>CR02F066</p>	<p>E165-2</p>  <p>CR02F066</p>	<p>E165-3</p>  <p>CR02F066</p>	<p>E165-4</p>  <p>CR02F066</p>
<p>E165-5</p>  <p>CR02F066</p>	<p>E165-6</p>  <p>CR02F066</p>	<p>E200-1</p>  <p>CR35F004</p>	
<p>E200-2</p>  <p>CR28F003</p>		<p>E200-3</p>  <p>CR30F009</p>	
<p>E201</p>  <p>CR05F007</p>	<p>E202</p>  <p>CR04F026</p>	<p>E203</p>  <p>CR05F007</p>	<p>E204</p>  <p>CR04F071</p>

FRONT HARNESS (7)

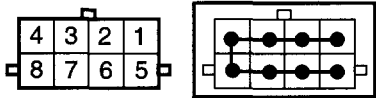
<p>E205</p>  <p>CR06F016</p>	<p>E207</p>  <p>CR04F027</p>	<p>E208</p>  <p>CR04F027</p>	<p>E209</p>  <p>CR04F027</p>
<p>E210</p>  <p>CR01F047</p>	<p>E211</p>  <p>CR04F054</p>	<p>E212</p>  <p>CR03F020</p>	<p>E213</p>  <p>CR03F047</p>
<p>E214</p>  <p>CR05F039</p>	<p>E215</p>  <p>CR03M015</p>	<p>E216</p>  <p>CR02F040</p>	<p>E217</p>  <p>CR04F005</p>
<p>E218</p>  <p>CR02F104</p>	<p>E219</p>  <p>CR01F020</p>	<p>E220</p>  <p>CR04F027</p>	<p>BLANK</p>
<p>E222</p>  <p>CR12F014</p>	<p>E223</p>  <p>CR02F061</p>	<p>BLANK</p>	<p>E225</p>  <p>CR03F020</p>
<p>E227</p>  <p>CR20F042</p>		<p>E228</p>  <p>CR20F041</p>	

FRONT HARNESS (8)

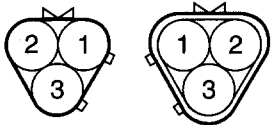
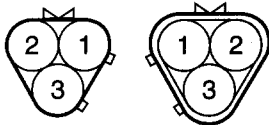
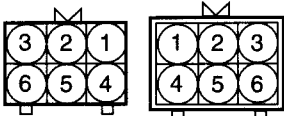
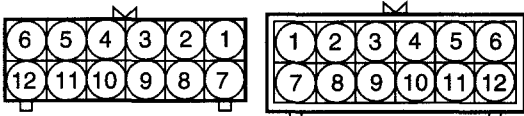
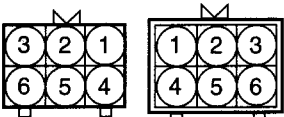
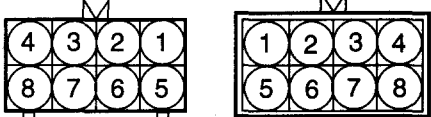
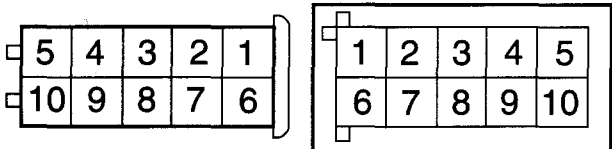
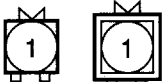
<p style="text-align: center;">E229</p>  <p style="text-align: right; font-size: small;">CR08F047</p>	<p style="text-align: center;">BLANK</p>	<p style="text-align: center;">E250</p>  <p style="text-align: right; font-size: small;">CR04F074</p>	
<p style="text-align: center;">E251</p>  <p style="text-align: right; font-size: small;">CR01F002</p>	<p style="text-align: center;">BLANK</p>	<p style="text-align: center;">E253</p>  <p style="text-align: right; font-size: small;">CR01F006</p>	<p style="text-align: center;">E254</p>  <p style="text-align: right; font-size: small;">CR01F002</p>
<p style="text-align: center;">EE01</p>  <p style="text-align: right; font-size: small;">CR03B007</p>		<p style="text-align: center;">EE02</p>  <p style="text-align: right; font-size: small;">CR03B007</p>	
<p style="text-align: center;">EE03</p>  <p style="text-align: right; font-size: small;">CR06B004</p>		<p style="text-align: center;">EE04</p>  <p style="text-align: right; font-size: small;">CR12B005</p>	
<p style="text-align: center;">EE05</p>  <p style="text-align: right; font-size: small;">CR06B004</p>		<p style="text-align: center;">EE06</p>  <p style="text-align: right; font-size: small;">CR08B005</p>	
<p style="text-align: center;">EE07</p>  <p style="text-align: right; font-size: small;">CR10B013</p>		<p style="text-align: center;">EE08</p>  <p style="text-align: right; font-size: small;">CR01B002</p>	<p style="text-align: center;">BLANK</p>



FRONT HARNESS (9)

<p>EM01</p> <div style="display: flex; justify-content: space-around; align-items: center;"> <table border="1" style="border-collapse: collapse; text-align: center;"> <tr><td>4</td><td>3</td><td>2</td><td>1</td></tr> <tr><td>8</td><td>7</td><td>6</td><td>5</td></tr> </table> <table border="1" style="border-collapse: collapse; text-align: center;"> <tr><td>1</td><td>2</td><td>3</td><td>4</td></tr> <tr><td>5</td><td>6</td><td>7</td><td>8</td></tr> </table> </div> <p style="text-align: right; font-size: small;">CR08B007</p>	4	3	2	1	8	7	6	5	1	2	3	4	5	6	7	8	<p>EM02</p> <div style="display: flex; flex-direction: column; align-items: center;"> <table border="1" style="border-collapse: collapse; text-align: center;"> <tr><td>10</td><td>9</td><td>8</td><td>7</td><td>6</td><td>5</td><td>4</td><td>3</td><td>2</td><td>1</td></tr> <tr><td>22</td><td>21</td><td>20</td><td>19</td><td>18</td><td>17</td><td>16</td><td>15</td><td>14</td><td>13</td><td>12</td><td>11</td></tr> </table> <table border="1" style="border-collapse: collapse; text-align: center;"> <tr><td>1</td><td>2</td><td>3</td><td>4</td><td>5</td><td>6</td><td>7</td><td>8</td><td>9</td><td>10</td></tr> <tr><td>11</td><td>12</td><td>13</td><td>14</td><td>15</td><td>16</td><td>17</td><td>18</td><td>19</td><td>20</td><td>21</td><td>22</td></tr> </table> </div> <p style="text-align: right; font-size: small;">CR22B006</p>	10	9	8	7	6	5	4	3	2	1	22	21	20	19	18	17	16	15	14	13	12	11	1	2	3	4	5	6	7	8	9	10	11	12	13	14	15	16	17	18	19	20	21	22					
4	3	2	1																																																															
8	7	6	5																																																															
1	2	3	4																																																															
5	6	7	8																																																															
10	9	8	7	6	5	4	3	2	1																																																									
22	21	20	19	18	17	16	15	14	13	12	11																																																							
1	2	3	4	5	6	7	8	9	10																																																									
11	12	13	14	15	16	17	18	19	20	21	22																																																							
<p>EM03</p> <div style="display: flex; flex-direction: column; align-items: center;"> <table border="1" style="border-collapse: collapse; text-align: center;"> <tr><td>9</td><td>8</td><td>7</td><td>6</td><td>5</td><td>4</td><td>3</td><td>2</td><td>1</td></tr> <tr><td>20</td><td>19</td><td>18</td><td>17</td><td>16</td><td>15</td><td>14</td><td>13</td><td>12</td><td>11</td><td>10</td></tr> </table> <table border="1" style="border-collapse: collapse; text-align: center;"> <tr><td>1</td><td>2</td><td>3</td><td>4</td><td>5</td><td>6</td><td>7</td><td>8</td><td>9</td></tr> <tr><td>10</td><td>11</td><td>12</td><td>13</td><td>14</td><td>15</td><td>16</td><td>17</td><td>18</td><td>19</td><td>20</td></tr> </table> </div> <p style="text-align: right; font-size: small;">CR20B007</p>	9	8	7	6	5	4	3	2	1	20	19	18	17	16	15	14	13	12	11	10	1	2	3	4	5	6	7	8	9	10	11	12	13	14	15	16	17	18	19	20	<p>BLANK</p>																									
9	8	7	6	5	4	3	2	1																																																										
20	19	18	17	16	15	14	13	12	11	10																																																								
1	2	3	4	5	6	7	8	9																																																										
10	11	12	13	14	15	16	17	18	19	20																																																								
<p>EM05</p> <div style="display: flex; justify-content: space-around; align-items: center;"> <table border="1" style="border-collapse: collapse; text-align: center;"> <tr><td>11</td><td>10</td><td>9</td><td>8</td><td>7</td><td>6</td><td>5</td><td>4</td><td>3</td><td>2</td><td>1</td></tr> <tr><td>22</td><td>21</td><td>20</td><td>19</td><td>18</td><td>17</td><td>16</td><td>15</td><td>14</td><td>13</td><td>12</td></tr> <tr><td>32</td><td>31</td><td>30</td><td>29</td><td>28</td><td>27</td><td>26</td><td>25</td><td>24</td><td>23</td></tr> </table> <table border="1" style="border-collapse: collapse; text-align: center;"> <tr><td>1</td><td>2</td><td>3</td><td>4</td><td>5</td><td>6</td><td>7</td><td>8</td><td>9</td><td>10</td><td>11</td></tr> <tr><td>12</td><td>13</td><td>14</td><td>15</td><td>16</td><td>17</td><td>18</td><td>19</td><td>20</td><td>21</td><td>22</td></tr> <tr><td>23</td><td>24</td><td>25</td><td>26</td><td>27</td><td>28</td><td>29</td><td>30</td><td>31</td><td>32</td></tr> </table> </div> <p style="text-align: right; font-size: small;">CR32B002</p>			11	10	9	8	7	6	5	4	3	2	1	22	21	20	19	18	17	16	15	14	13	12	32	31	30	29	28	27	26	25	24	23	1	2	3	4	5	6	7	8	9	10	11	12	13	14	15	16	17	18	19	20	21	22	23	24	25	26	27	28	29	30	31	32
11	10	9	8	7	6	5	4	3	2	1																																																								
22	21	20	19	18	17	16	15	14	13	12																																																								
32	31	30	29	28	27	26	25	24	23																																																									
1	2	3	4	5	6	7	8	9	10	11																																																								
12	13	14	15	16	17	18	19	20	21	22																																																								
23	24	25	26	27	28	29	30	31	32																																																									
<p>EM06</p> <div style="display: flex; flex-direction: column; align-items: center;"> <table border="1" style="border-collapse: collapse; text-align: center;"> <tr><td>9</td><td>8</td><td>7</td><td>6</td><td>5</td><td>4</td><td>3</td><td>2</td><td>1</td></tr> <tr><td>20</td><td>19</td><td>18</td><td>17</td><td>16</td><td>15</td><td>14</td><td>13</td><td>12</td><td>11</td><td>10</td></tr> </table> <table border="1" style="border-collapse: collapse; text-align: center;"> <tr><td>1</td><td>2</td><td>3</td><td>4</td><td>5</td><td>6</td><td>7</td><td>8</td><td>9</td></tr> <tr><td>10</td><td>11</td><td>12</td><td>13</td><td>14</td><td>15</td><td>16</td><td>17</td><td>18</td><td>19</td><td>20</td></tr> </table> </div> <p style="text-align: right; font-size: small;">CR20B007</p>	9	8	7	6	5	4	3	2	1	20	19	18	17	16	15	14	13	12	11	10	1	2	3	4	5	6	7	8	9	10	11	12	13	14	15	16	17	18	19	20	<p>BLANK</p>																									
9	8	7	6	5	4	3	2	1																																																										
20	19	18	17	16	15	14	13	12	11	10																																																								
1	2	3	4	5	6	7	8	9																																																										
10	11	12	13	14	15	16	17	18	19	20																																																								

INSTRUMENT HARNESS

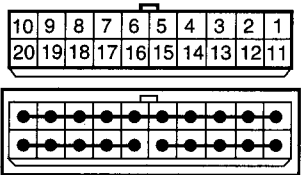
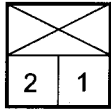
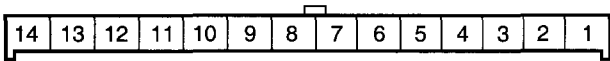
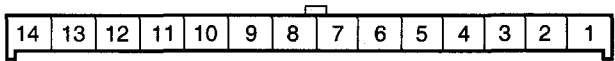
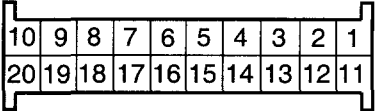

E1BBBFFB

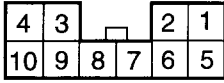
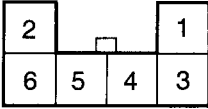
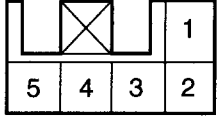
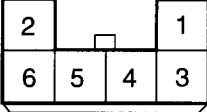
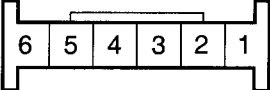
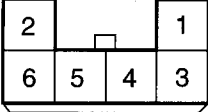
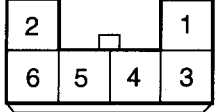
INSTRUMENT HARNESS (1)

<p style="text-align: center;">I01</p>  <p style="text-align: right;">CR20F039</p>	<p style="text-align: center;">I02</p>  <p style="text-align: right;">CR02F038</p>	<p style="text-align: center;">BLANK</p>	
<p style="text-align: center;">I03-1</p>  <p style="text-align: right;">CR14F007</p>	<p style="text-align: center;">I03-2</p>  <p style="text-align: right;">CR14F007</p>		
<p style="text-align: center;">I03-3</p>  <p style="text-align: right;">CR20F020</p>	<p style="text-align: center;">I04</p>  <p style="text-align: right;">CR05F016</p>	<p style="text-align: center;">BLANK</p>	
<p style="text-align: center;">I06</p>  <p style="text-align: right;">CR10F004</p>	<p style="text-align: center;">BLANK</p>	<p style="text-align: center;">I08</p>  <p style="text-align: right;">CR06F003</p>	<p style="text-align: center;">I09</p>  <p style="text-align: right;">CR05F013</p>
<p style="text-align: center;">I10</p>  <p style="text-align: right;">CR06F017</p>	<p style="text-align: center;">I12</p>  <p style="text-align: right;">CR06F027</p>	<p style="text-align: center;">I13</p>  <p style="text-align: right;">CR06F017</p>	<p style="text-align: center;">I14</p>  <p style="text-align: right;">CR06F017</p>

T/M HARNESS E3C4015E

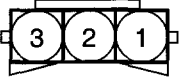
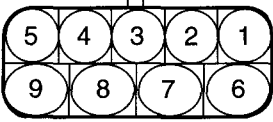
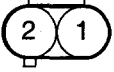

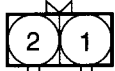
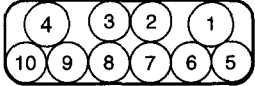
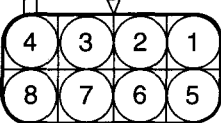
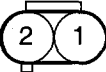
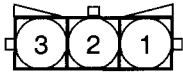
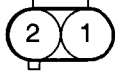
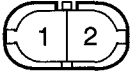
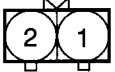
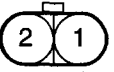
T/M HARNESS (1)

<p style="text-align: center;">C01</p>  <p style="text-align: right; font-size: small;">CR03F038</p>	<p style="text-align: center;">C02</p>  <p style="text-align: right; font-size: small;">CR09F011</p>	<p style="text-align: center;">BLANK</p>	<p style="text-align: center;">C03</p>  <p style="text-align: right; font-size: small;">CR02F043</p>
<p style="text-align: center;">C04</p>  <p style="text-align: right; font-size: small;">CR03F003</p>	<p style="text-align: center;">BLANK</p>	<p style="text-align: center;">C05</p>  <p style="text-align: right; font-size: small;">CR02F040</p>	<p style="text-align: center;">C06</p>  <p style="text-align: right; font-size: small;">CR10F021</p>
<p style="text-align: center;">C07</p>  <p style="text-align: right; font-size: small;">CR08F048</p>	<p style="text-align: center;">C08</p>  <p style="text-align: right; font-size: small;">CR02F043</p>	<p style="text-align: center;">C09</p>  <p style="text-align: right; font-size: small;">CR03F021</p>	<p style="text-align: center;">BLANK</p>
<p style="text-align: center;">C10</p>  <p style="text-align: right; font-size: small;">CR02F043</p>	<p style="text-align: center;">C11</p>  <p style="text-align: right; font-size: small;">CR02M007</p>	<p style="text-align: center;">C12</p>  <p style="text-align: right; font-size: small;">CR02F040</p>	<p style="text-align: center;">C13</p>  <p style="text-align: right; font-size: small;">CR02F001</p>

DOOR HARNESS

E144ECC6

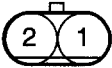
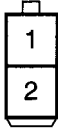
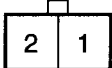
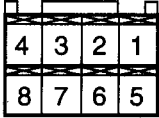
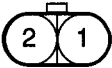
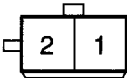
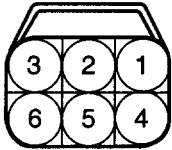
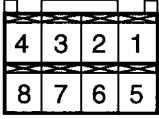
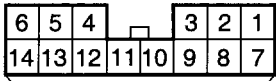
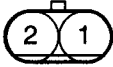
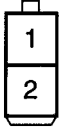
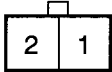
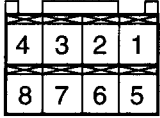
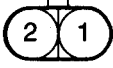
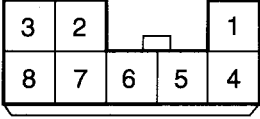
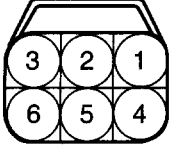
DOOR HARNESS (1)

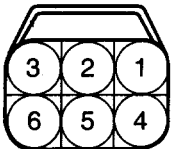
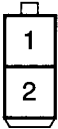
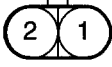
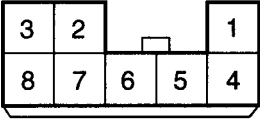
<p>D01</p>  <p>CR02F075</p>	<p>D02</p>  <p>CR02F052</p>	<p>D03</p>  <p>CR02F076</p>	<p>D04</p>  <p>CR08F049</p>
<p>D05</p>  <p>CR02F001</p>	<p>BLANK</p>	<p>D07</p>  <p>CR02F046</p>	<p>D08</p>  <p>CR06F040</p>
<p>D09</p>  <p>CR08F049</p>	<p>D10</p>  <p>CR14F019</p>		<p>D11</p>  <p>CR02F075</p>
<p>D12</p>  <p>CR02F052</p>	<p>D13</p>  <p>CR02F076</p>	<p>D14</p>  <p>CR08F049</p>	<p>D15</p>  <p>CR02F001</p>
<p>BLANK</p>	<p>D17</p>  <p>CR08F010</p>	<p>D18</p>  <p>CR06F040</p>	<p>D19</p>  <p>CR02F046</p>
<p>D21</p>  <p>CR06F040</p>	<p>D22</p>  <p>CR02F052</p>	<p>D23</p>  <p>CR02F001</p>	<p>D24</p>  <p>CR08F010</p>



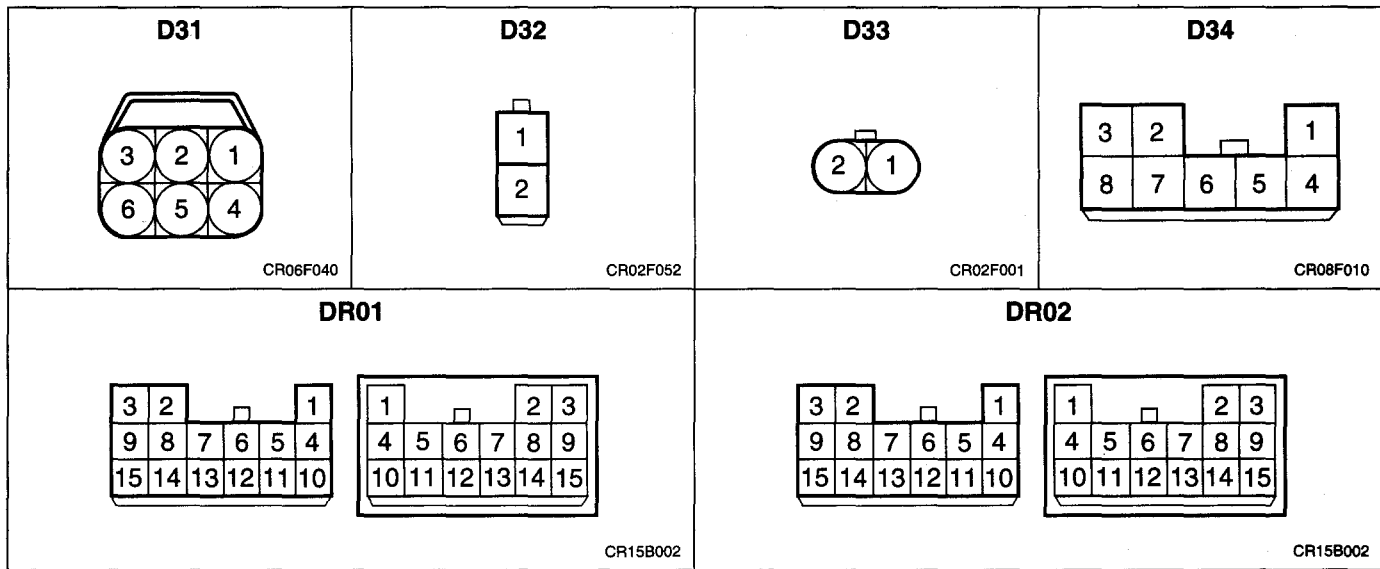



DOOR HARNESS (2)



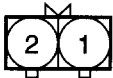
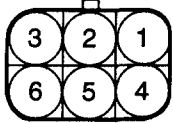
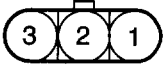
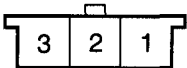

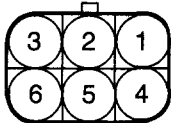
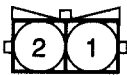
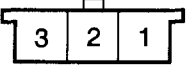

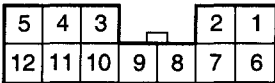
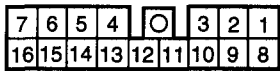
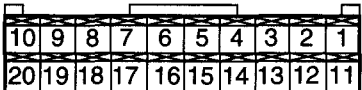
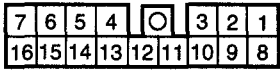

REAR HARNESS

E21C9F63

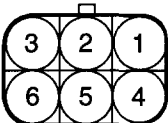
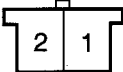
REAR HARNESS (1)

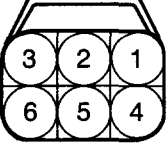
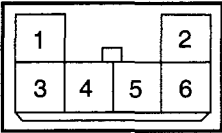
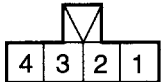
<p>R02</p>  <p>CR03F052</p>	<p>R03</p>  <p>CR02F040</p>	<p>BLANK</p>	<p>R05</p>  <p>CR06F011</p>
<p>R06</p>  <p>CR03F016</p>	<p>R07</p>  <p>CR03F052</p>	<p>R08</p>  <p>CR23F004</p>	
<p>R09</p>  <p>CR01M013</p>	<p>BLANK</p>	<p>R11</p>  <p>CR06F011</p>	<p>R12</p>  <p>CR02F041</p>
<p>R15</p>  <p>CR03F052</p>	<p>R16</p>  <p>CR02F040</p>	<p>R17</p>  <p>CR03F052</p>	<p>R18</p>  <p>CR02F012</p>
<p>R20-1</p>  <p>CR12F020</p>		<p>R20-2</p>  <p>CR16F014</p>	
<p>R22</p>  <p>CR20F013</p>		<p>R23</p>  <p>CR16F014</p>	

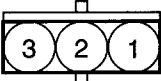
REAR HARNESS (2)

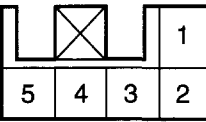
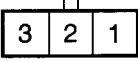
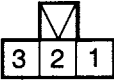
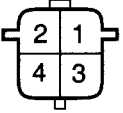
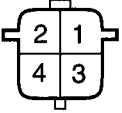
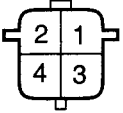
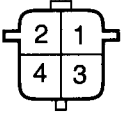
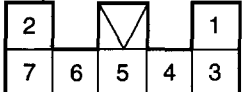
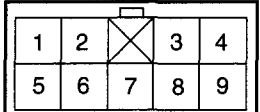
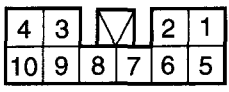
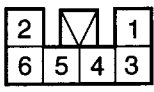
<p>R25</p>  <p>CR06F011</p>	<p>BLANK</p>	<p>R30</p>  <p>CR02F096</p>	<p>R31</p>  <p>CR01F006</p>
<p>R32</p>  <p>CR06F040</p>	<p>R33</p>  <p>CR06M002</p>	<p>R34</p>  <p>CR04F010</p>	<p>R35</p>  <p>CR01F006</p>
<p>R37</p>  <p>CR01F006</p>	<p>BLANK</p>	<p>R40</p>  <p>CR03F037</p>	<p>R41</p>  <p>CR08F050</p>
<p>R42</p>  <p>CR05F013</p>	<p>BLANK</p>	<p>R45</p>  <p>CR03F040</p>	<p>R46</p>  <p>CR03F007</p>
<p>R50</p>  <p>CR04F026</p>	<p>R51</p>  <p>CR04F026</p>	<p>R52</p>  <p>CR04F026</p>	<p>R53</p>  <p>CR04F026</p>
<p>R55</p>  <p>CR07F015</p>	<p>R56</p>  <p>CR09M001</p>	<p>R57-1</p>  <p>CR10F003</p>	<p>R57-2</p>  <p>CR06F005</p>

REAR HARNESS (3)

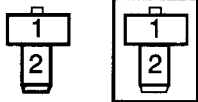
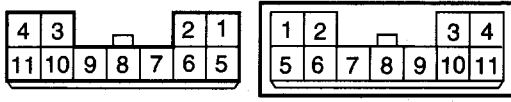
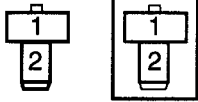
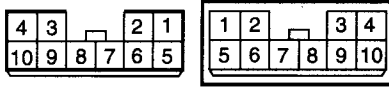
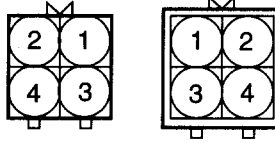
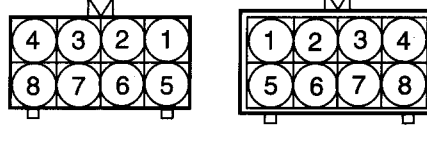
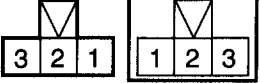
<p style="text-align: center;">RR01</p>  <p style="text-align: right;">CR02B002</p>	<p style="text-align: center;">RR02</p>  <p style="text-align: right;">CR11B004</p>	
<p style="text-align: center;">RR03</p>  <p style="text-align: right;">CR02B002</p>	<p style="text-align: center;">RR04</p>  <p style="text-align: right;">CR10B006</p>	
<p style="text-align: center;">RR05</p>  <p style="text-align: right;">CR04B007</p>	<p style="text-align: center;">RR06</p>  <p style="text-align: right;">CR08B005</p>	
<p style="text-align: center;">RR08</p>  <p style="text-align: right;">CR03B001</p>	<p style="text-align: center;">BLANK</p>	<p style="text-align: center;">BLANK</p>

A/C & A/BAG HARNESS EEBB6BB3

A/C & A/BAG HARNESS (1)

<p>A01</p> <table border="1" style="margin: auto;"> <tr><td>3</td><td>2</td><td>1</td></tr> <tr><td>6</td><td>5</td><td>4</td></tr> </table> <p style="text-align: right; font-size: small;">CR06F002</p>	3	2	1	6	5	4	<p>A02</p> <table border="1" style="margin: auto;"> <tr><td>8</td><td>7</td><td>6</td><td>5</td><td>4</td><td>3</td><td>2</td><td>1</td></tr> <tr><td>16</td><td>15</td><td>14</td><td>13</td><td>12</td><td>11</td><td>10</td><td>9</td></tr> </table> <p style="text-align: right; font-size: small;">CR16F015</p>	8	7	6	5	4	3	2	1	16	15	14	13	12	11	10	9	<p>A03</p> <table border="1" style="margin: auto;"> <tr><td>3</td><td>2</td><td>∇</td><td>1</td></tr> <tr><td>8</td><td>7</td><td>6</td><td>5</td><td>4</td></tr> </table> <p style="text-align: right; font-size: small;">CR08F004</p>	3	2	∇	1	8	7	6	5	4																						
3	2	1																																																					
6	5	4																																																					
8	7	6	5	4	3	2	1																																																
16	15	14	13	12	11	10	9																																																
3	2	∇	1																																																				
8	7	6	5	4																																																			
<p>A05-1</p> <table border="1" style="margin: auto;"> <tr><td>13</td><td>12</td><td>11</td><td>10</td><td>9</td><td>8</td><td>7</td><td>6</td><td>5</td><td>4</td><td>3</td><td>2</td><td>1</td></tr> <tr><td>26</td><td>25</td><td>24</td><td>23</td><td>22</td><td>21</td><td>20</td><td>19</td><td>18</td><td>17</td><td>16</td><td>15</td><td>14</td></tr> </table> <p style="text-align: right; font-size: small;">CR26F005</p>		13	12	11	10	9	8	7	6	5	4	3	2	1	26	25	24	23	22	21	20	19	18	17	16	15	14	<p>A05-2</p> <table border="1" style="margin: auto;"> <tr><td>8</td><td>7</td><td>6</td><td>5</td><td>4</td><td>3</td><td>2</td><td>1</td></tr> <tr><td>16</td><td>15</td><td>14</td><td>13</td><td>12</td><td>11</td><td>10</td><td>9</td></tr> </table> <p style="text-align: right; font-size: small;">CR16F016</p>		8	7	6	5	4	3	2	1	16	15	14	13	12	11	10	9										
13	12	11	10	9	8	7	6	5	4	3	2	1																																											
26	25	24	23	22	21	20	19	18	17	16	15	14																																											
8	7	6	5	4	3	2	1																																																
16	15	14	13	12	11	10	9																																																
<p>A06</p> <table border="1" style="margin: auto;"> <tr><td>3</td><td>2</td><td>1</td></tr> <tr><td>5</td><td>4</td></tr> </table> <p style="text-align: right; font-size: small;">CR05F003</p>	3	2	1	5	4	<p>A07</p> <table border="1" style="margin: auto;"> <tr><td>2</td><td>∇</td><td>1</td></tr> <tr><td>7</td><td>6</td><td>5</td><td>4</td><td>3</td></tr> </table> <p style="text-align: right; font-size: small;">CR07F005</p>	2	∇	1	7	6	5	4	3	<p>A08</p> <table border="1" style="margin: auto;"> <tr><td>2</td><td>1</td></tr> <tr><td>6</td><td>5</td><td>4</td><td>3</td></tr> </table> <p style="text-align: right; font-size: small;">CR06F003</p>	2	1	6	5	4	3	<p>BLANK</p>																																	
3	2	1																																																					
5	4																																																						
2	∇	1																																																					
7	6	5	4	3																																																			
2	1																																																						
6	5	4	3																																																				
<p>A09</p> <table border="1" style="margin: auto;"> <tr><td>5</td><td>4</td><td>3</td><td>2</td><td>1</td></tr> <tr><td>10</td><td>9</td><td>8</td><td>7</td><td>6</td></tr> </table> <p style="text-align: right; font-size: small;">CR10F020</p>		5	4	3	2	1	10	9	8	7	6	<p>A10</p> <table border="1" style="margin: auto;"> <tr><td>3</td><td>2</td><td>1</td></tr> </table> <p style="text-align: right; font-size: small;">CR03F011</p>	3	2	1	<p>A11</p> <table border="1" style="margin: auto;"> <tr><td>3</td><td>2</td><td>1</td></tr> </table> <p style="text-align: right; font-size: small;">CR03F011</p>	3	2	1																																				
5	4	3	2	1																																																			
10	9	8	7	6																																																			
3	2	1																																																					
3	2	1																																																					
<p>A12</p> <table border="1" style="margin: auto;"> <tr><td>1</td></tr> <tr><td>3</td><td>2</td></tr> </table> <p style="text-align: right; font-size: small;">CR03F005</p>	1	3	2	<p>A13</p> <table border="1" style="margin: auto;"> <tr><td>2</td><td>1</td></tr> <tr><td>4</td><td>3</td></tr> </table> <p style="text-align: right; font-size: small;">CR04F001</p>	2	1	4	3	<p>A14</p> <table border="1" style="margin: auto;"> <tr><td>3</td><td>2</td><td>1</td></tr> <tr><td>5</td><td>4</td></tr> </table> <p style="text-align: right; font-size: small;">CR05F003</p>	3	2	1	5	4	<p>A15</p> <table border="1" style="margin: auto;"> <tr><td>2</td><td>∇</td><td>1</td></tr> <tr><td>7</td><td>6</td><td>5</td><td>4</td><td>3</td></tr> </table> <p style="text-align: right; font-size: small;">CR07F005</p>	2	∇	1	7	6	5	4	3																																
1																																																							
3	2																																																						
2	1																																																						
4	3																																																						
3	2	1																																																					
5	4																																																						
2	∇	1																																																					
7	6	5	4	3																																																			
<p>A16</p> <table border="1" style="margin: auto;"> <tr><td>1</td></tr> <tr><td>2</td></tr> </table> <p style="text-align: right; font-size: small;">CR02F012</p>	1	2	<p>A20</p> <table border="1" style="margin: auto;"> <tr><td>25</td><td>24</td><td>23</td><td>22</td><td>21</td><td>20</td><td>19</td><td>18</td><td>17</td><td>16</td><td>15</td><td>14</td><td>13</td><td>12</td><td>11</td><td>10</td><td>9</td><td>8</td><td>7</td><td>6</td><td>5</td><td>4</td><td>3</td><td>2</td><td>1</td></tr> <tr><td>50</td><td>49</td><td>48</td><td>47</td><td>46</td><td>45</td><td>44</td><td>43</td><td>42</td><td>41</td><td>40</td><td>39</td><td>38</td><td>37</td><td>36</td><td>35</td><td>34</td><td>33</td><td>32</td><td>31</td><td>30</td><td>29</td><td>28</td><td>27</td><td>26</td></tr> </table> <p style="text-align: right; font-size: small;">CR50F001</p>			25	24	23	22	21	20	19	18	17	16	15	14	13	12	11	10	9	8	7	6	5	4	3	2	1	50	49	48	47	46	45	44	43	42	41	40	39	38	37	36	35	34	33	32	31	30	29	28	27	26
1																																																							
2																																																							
25	24	23	22	21	20	19	18	17	16	15	14	13	12	11	10	9	8	7	6	5	4	3	2	1																															
50	49	48	47	46	45	44	43	42	41	40	39	38	37	36	35	34	33	32	31	30	29	28	27	26																															

A/C & A/BAG HARNESS (2)

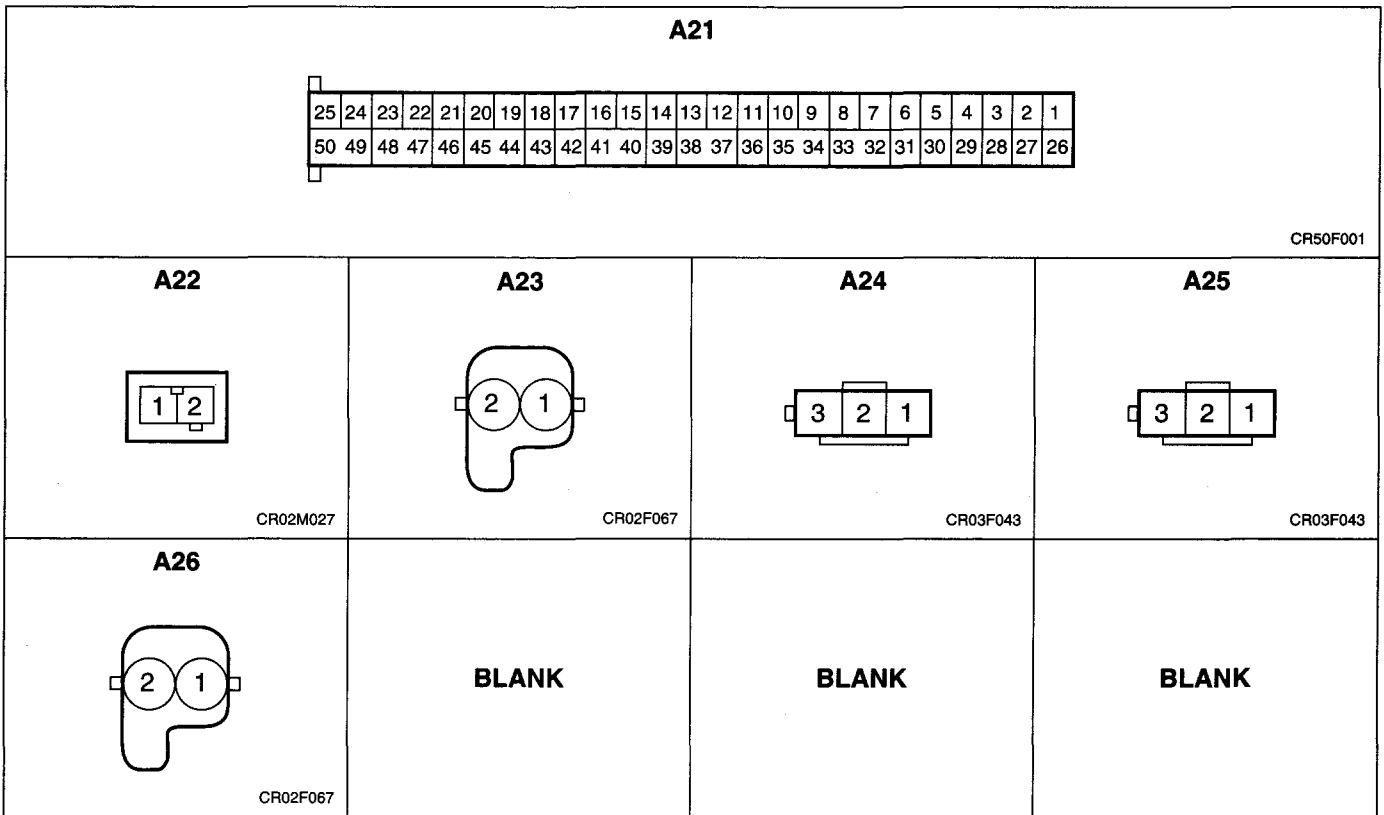

COMPONENT LOCATIONS

A/C & A/BAG HARNESS	CL-27
DOOR HARNESS	CL-22
FRONT HARNESS	CL-8
GROUNDS	CL-29
INSTRUMENT HARNESS	CL-20
MAIN HARNESS	CL-2
REAR HARNESS	CL-24
T/M HARNESS	CL-21



MAIN HARNESS

MAIN HARNESS(1)

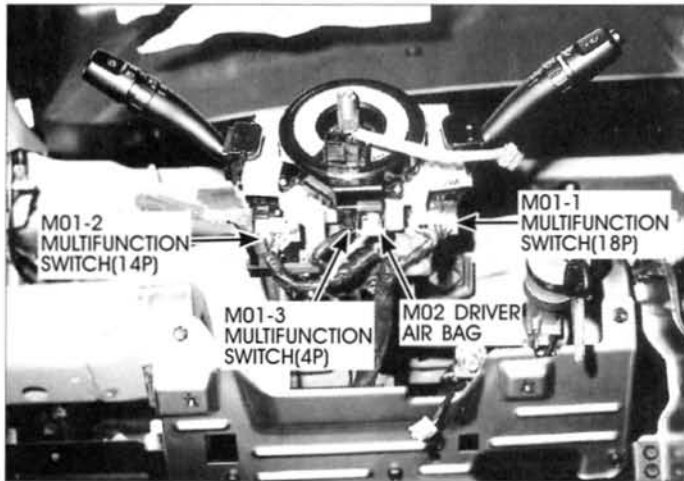

M01-1,M01-2,M01-3,M02

E3ME001A

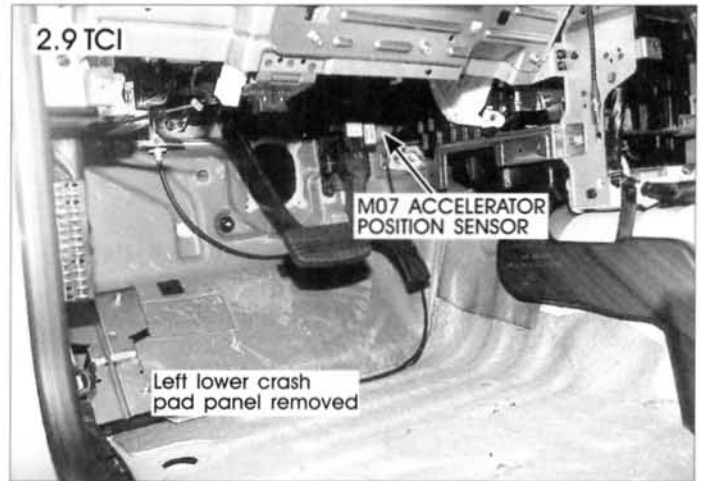

M07

E3ME001D

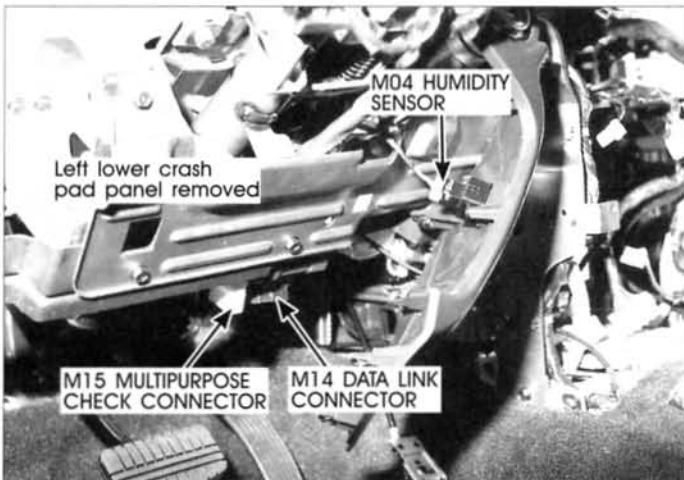

M04,M14,M15

E3ME001B

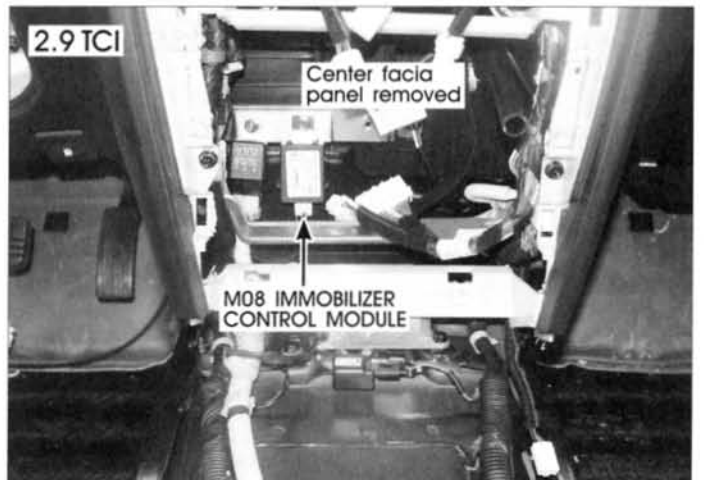

M08

E3ME001E

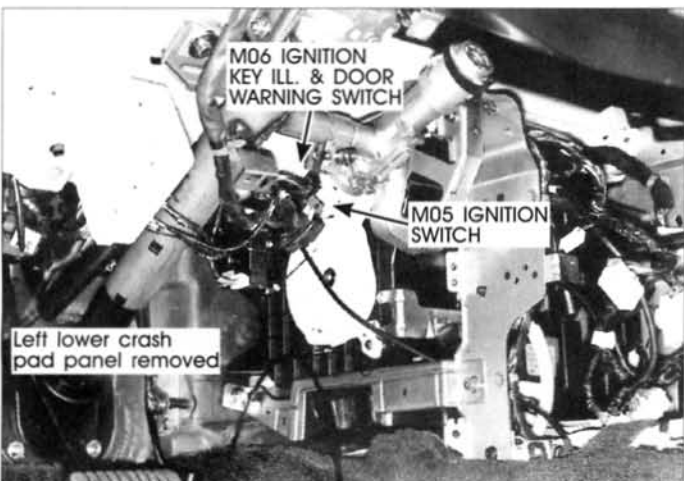

M05,M06

E3ME001C

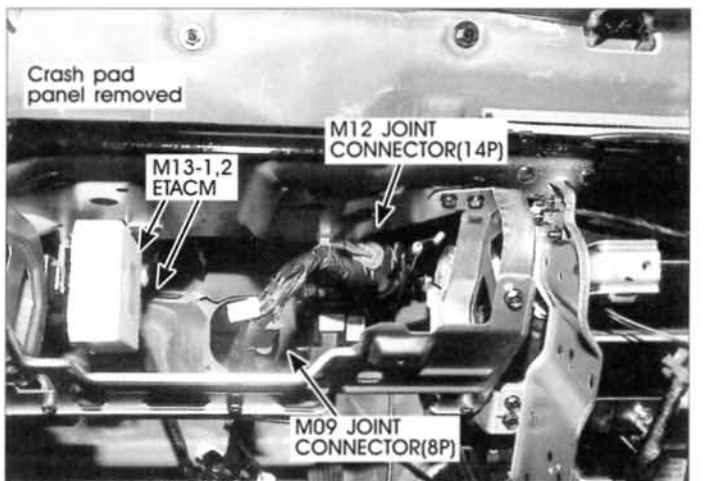

M09,M12,M13-1,M13-2

E3ME001F

MAIN HARNESS(2)

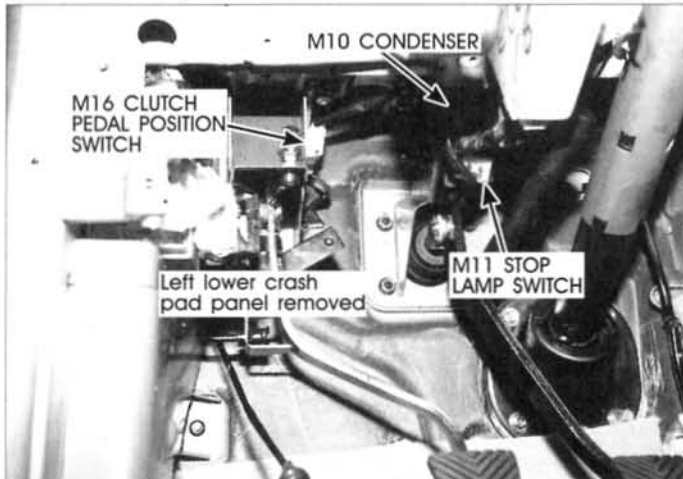

M10,M11,M16

E3ME001G

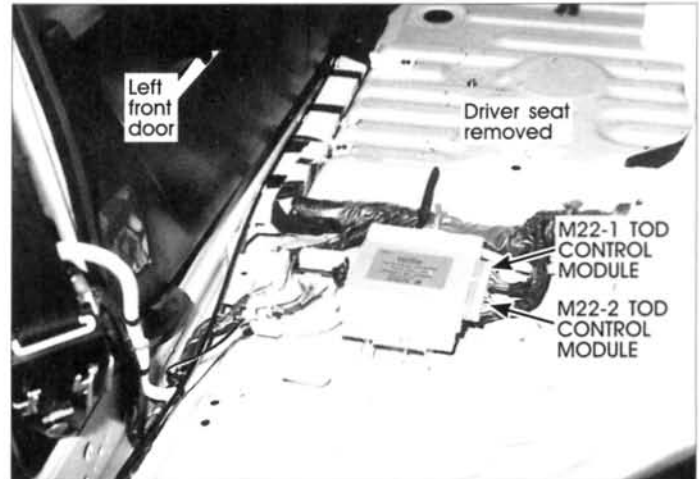

M22-1,M22-2

E3ME001K

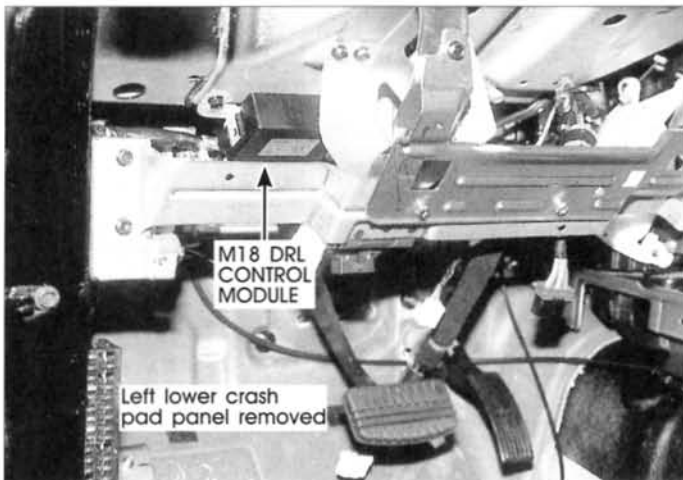

M18

E3ME001H

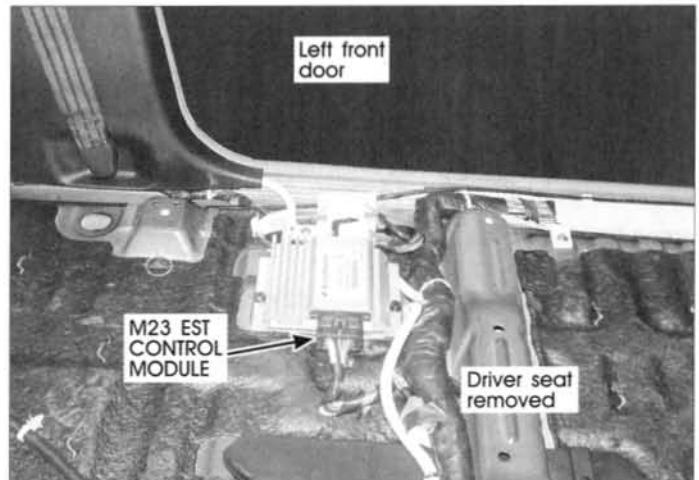

M23

E3ME001L

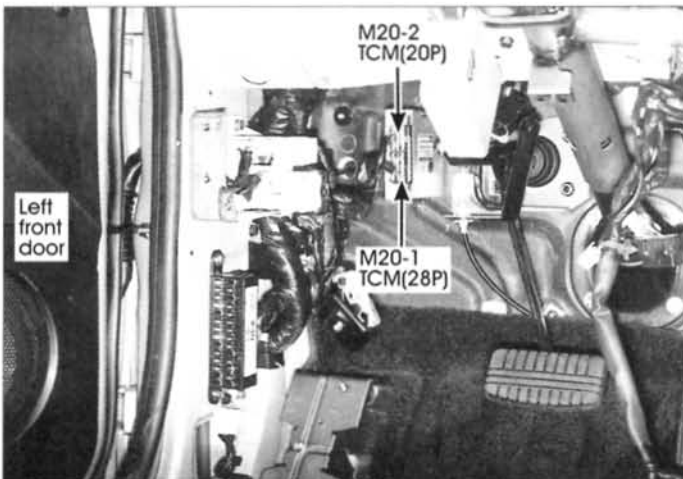

M20-1,M20-2

E3ME001J

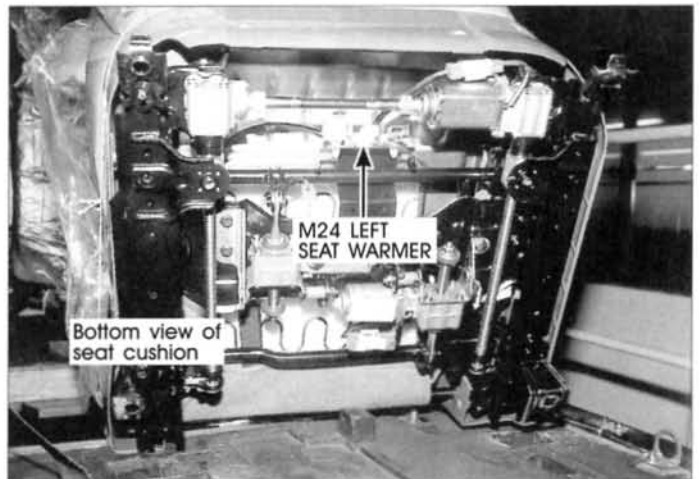

M24

E3ME001M

MAIN HARNESS(3)

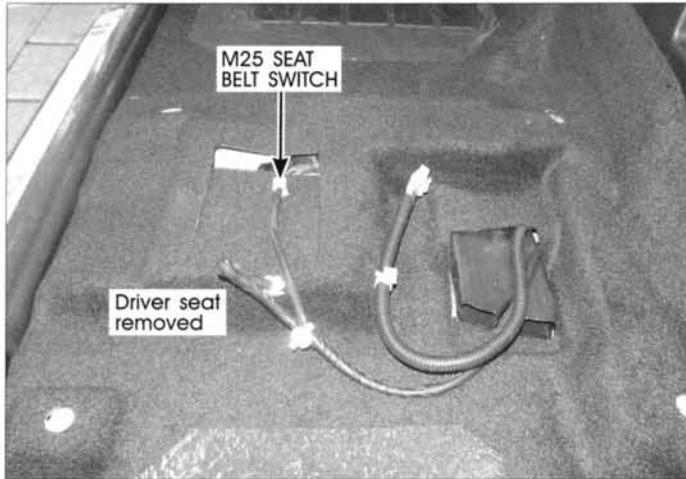

M25

E3ME001N

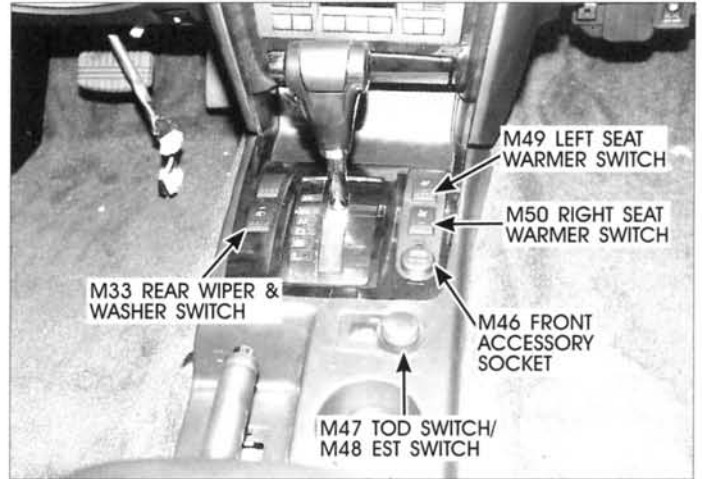

M33,M46,M47,M48,M49,M50

E3ME001R

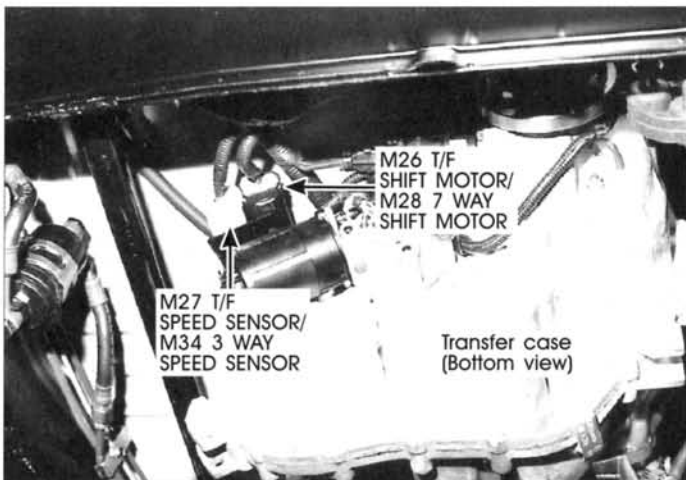

M26,M27,M28,M34

E3ME001P

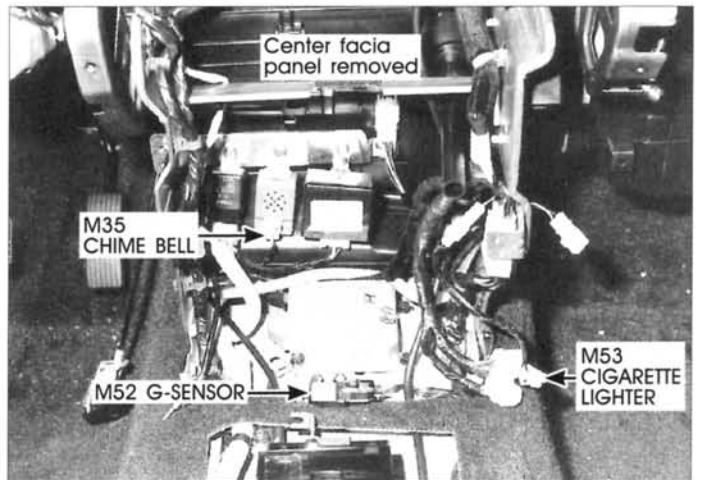

M35,M52,M53

E3ME001S

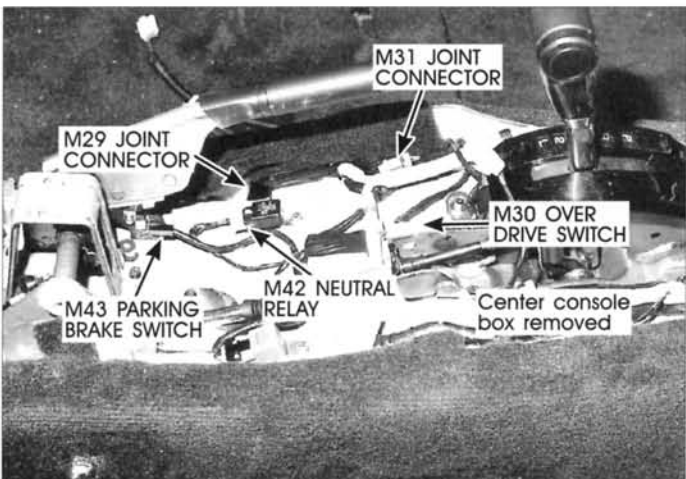

M29,M30,M31,M42,M43

E3ME001Q

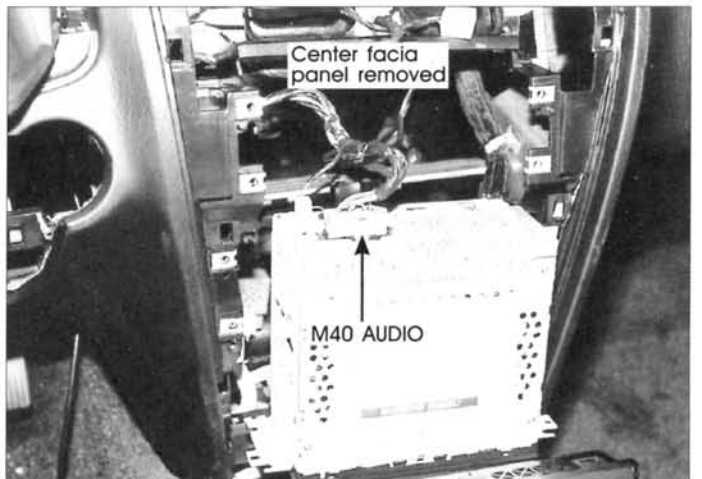

M40

E3ME001T

MAIN HARNESS(4)

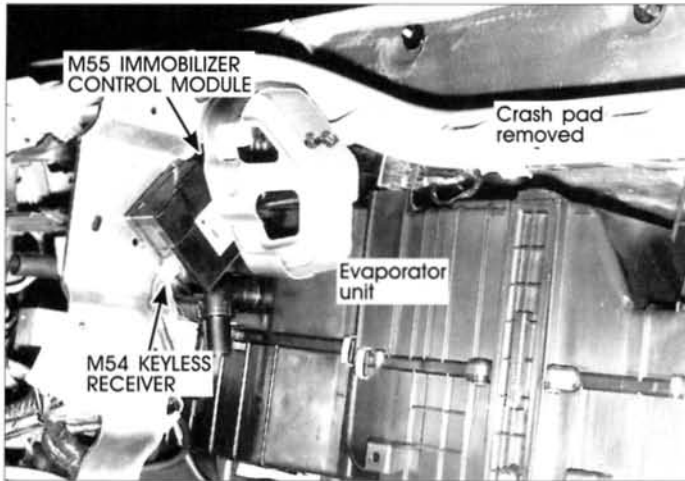

M54,M55

E3ME001U

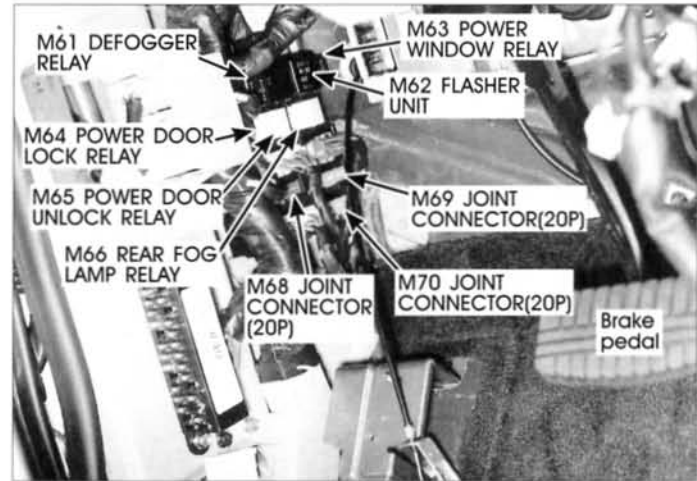

M61,M62,M63,M64,M65
M66,M68,M69,M70

E3ME001X

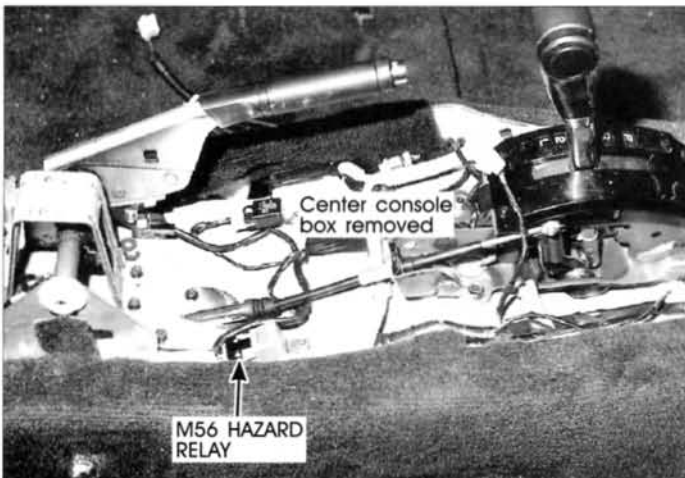

M56

E3ME001V

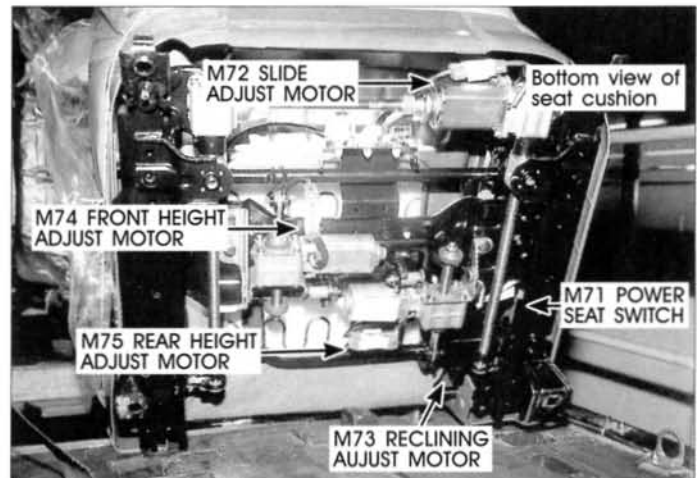

M71,M72,M73,M74,M75

E3ME001Y

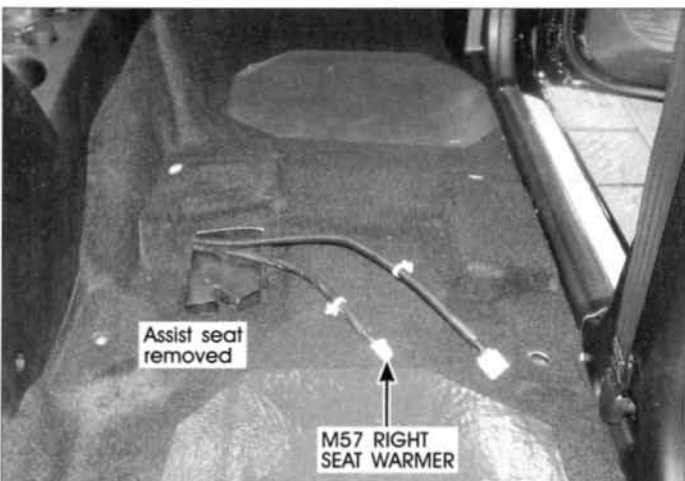

M57

E3ME001W

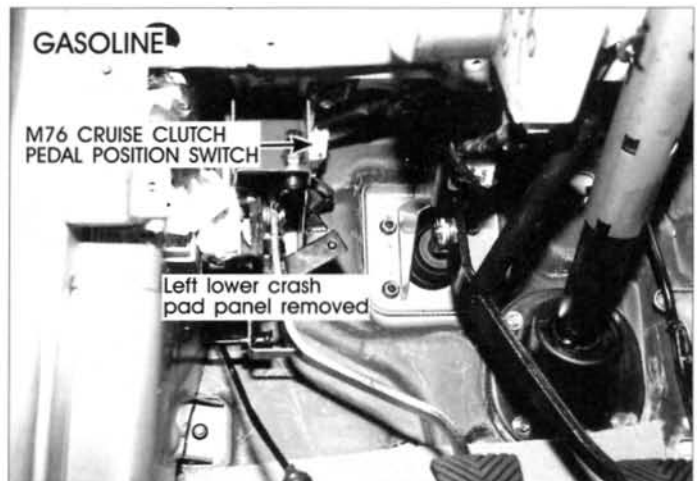

M76

E3ME001Z

MAIN HARNESS(5)

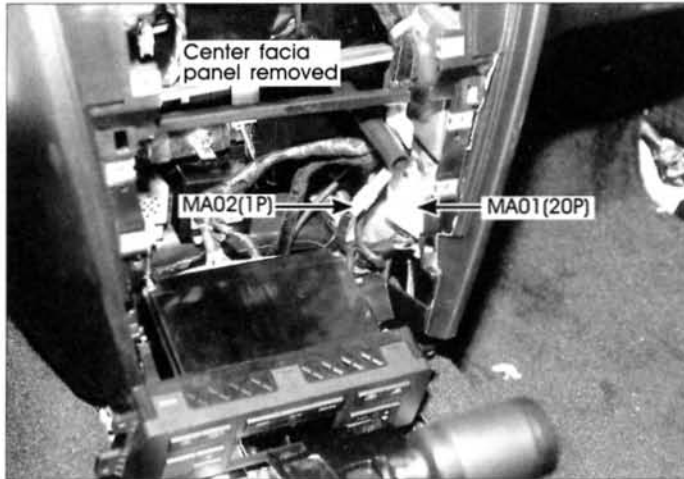

MA01,MA02

E3ME0A1A

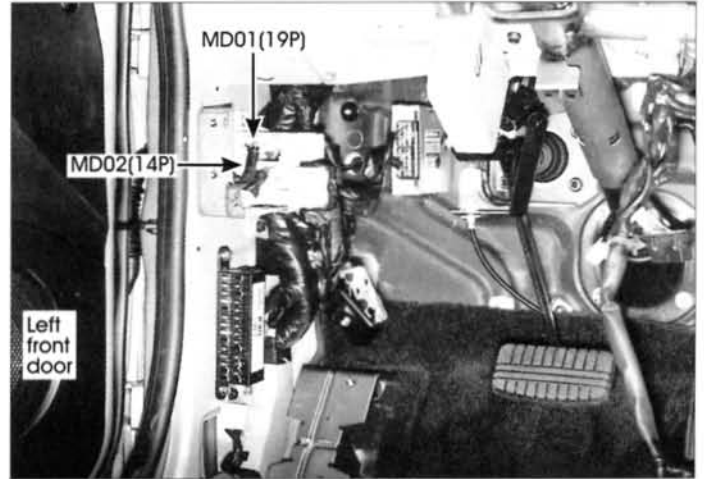

MD01,MD02

E3ME0A1D



MA03

E3ME0A1B

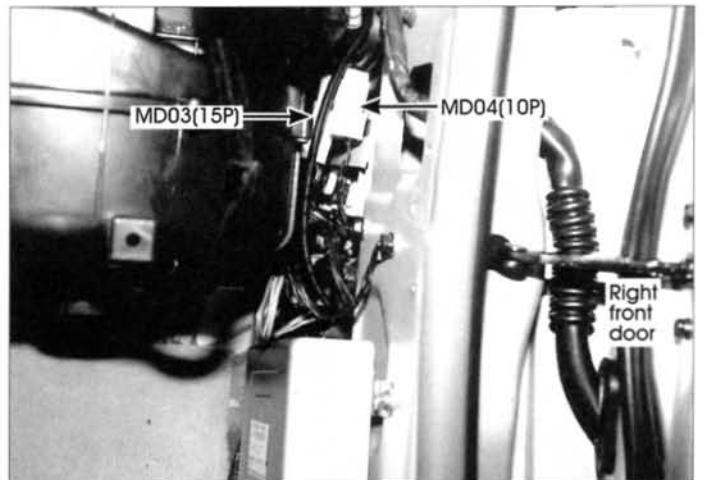

MD03,MD04

E3ME0A1E

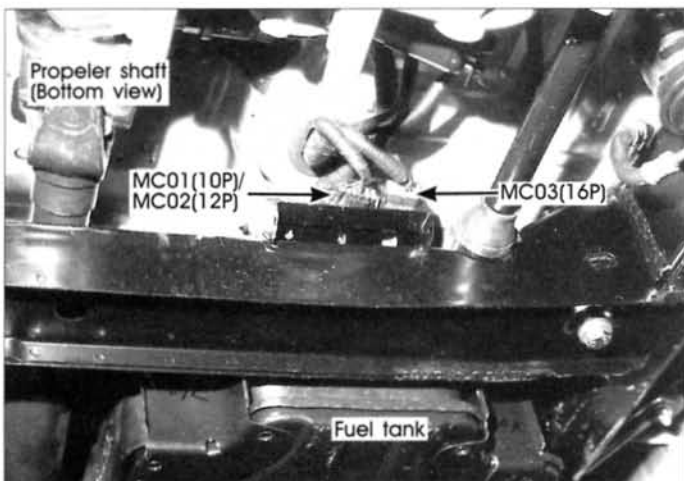

MC01,MC02,MC03

E3ME0A1C

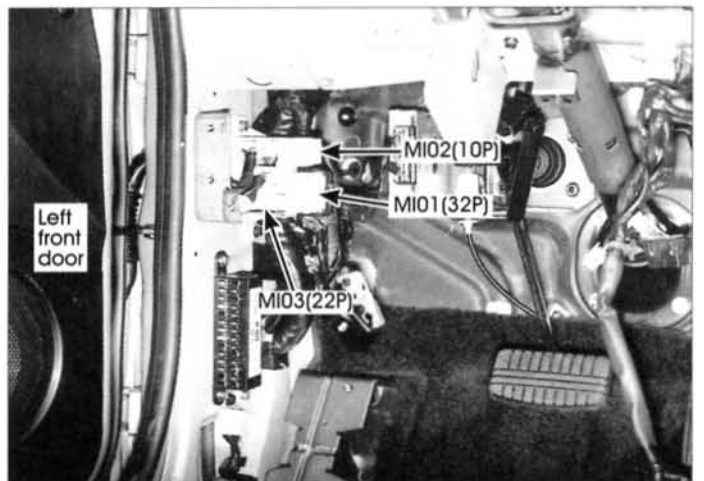

MI01,MI02,MI03

E3ME0A1F

MAIN HARNESS(6)

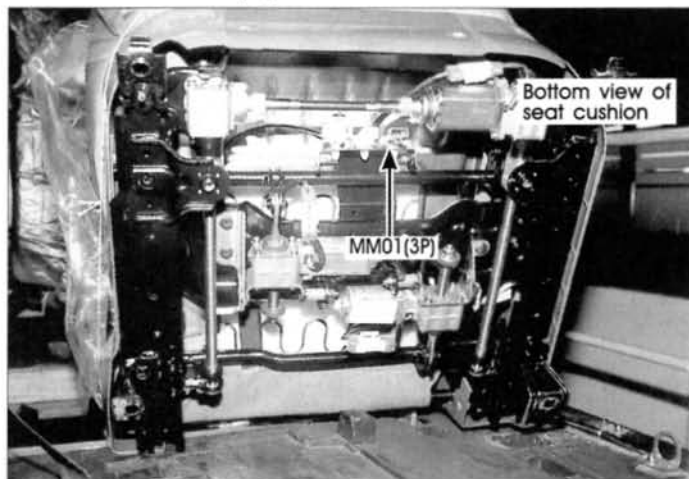

MM01

E3ME0A1G

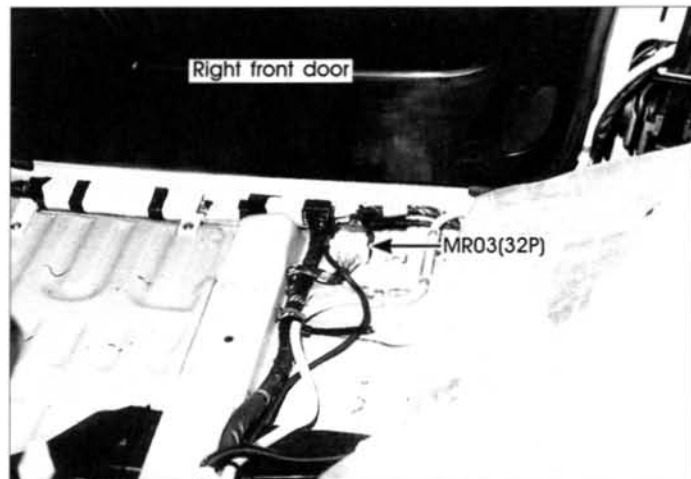

MR03

E3ME0A1J

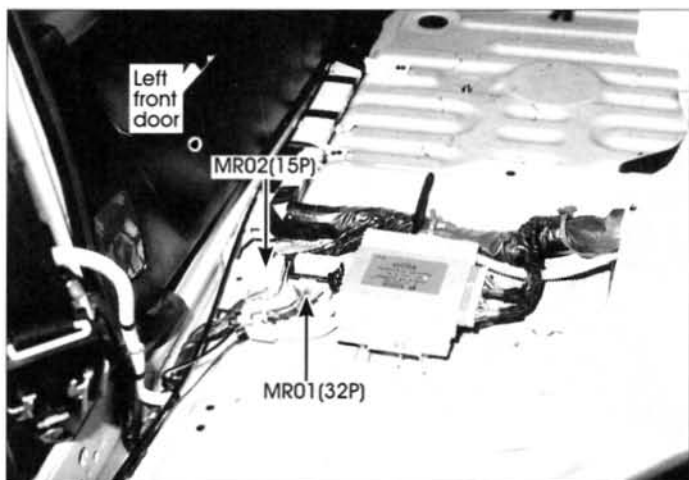

MR01,MR02

E3ME0A1H

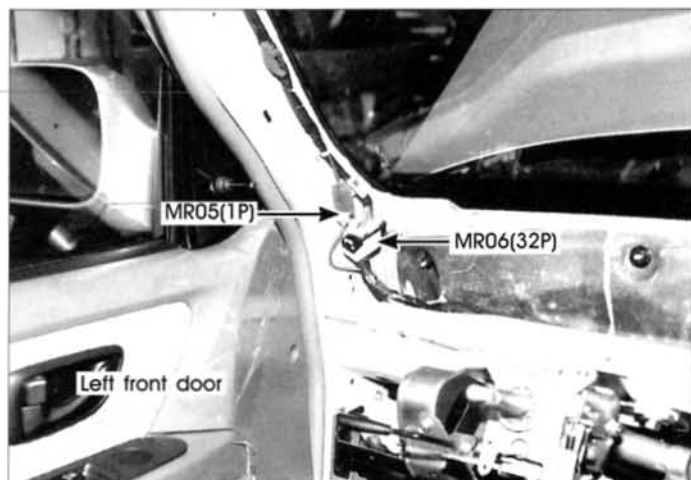

MR05,MR06

E3ME0A1K

FRONT HARNESS

FRONT HARNESS(1)

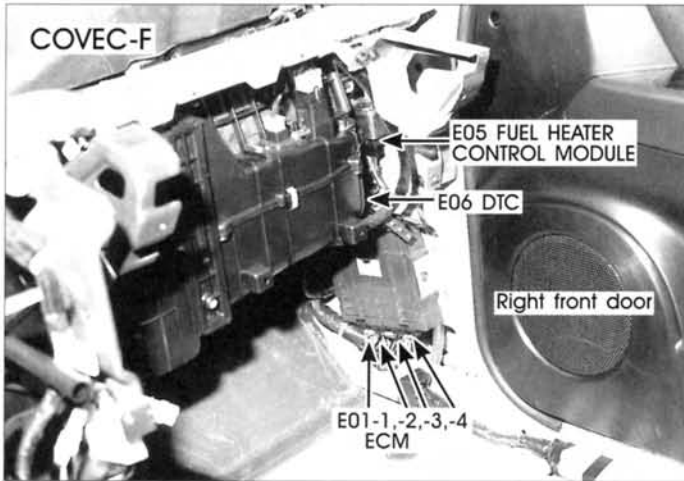

E01-1,E01-2,E01-3,E01-4,E05,E06

E3ME002A

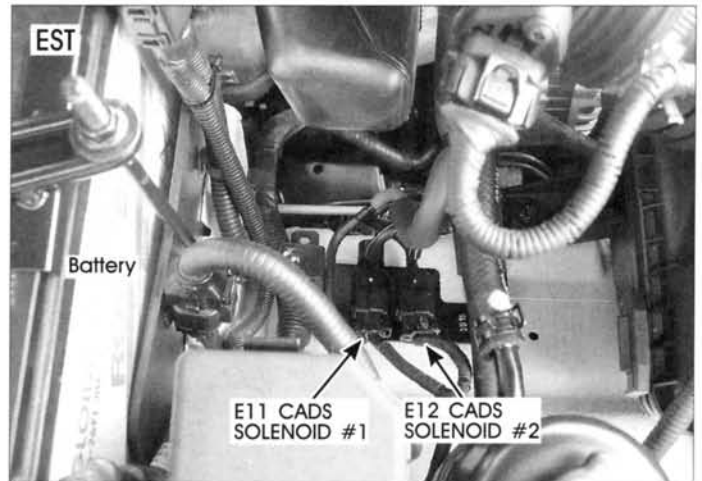

E11,E12

E3ME002D

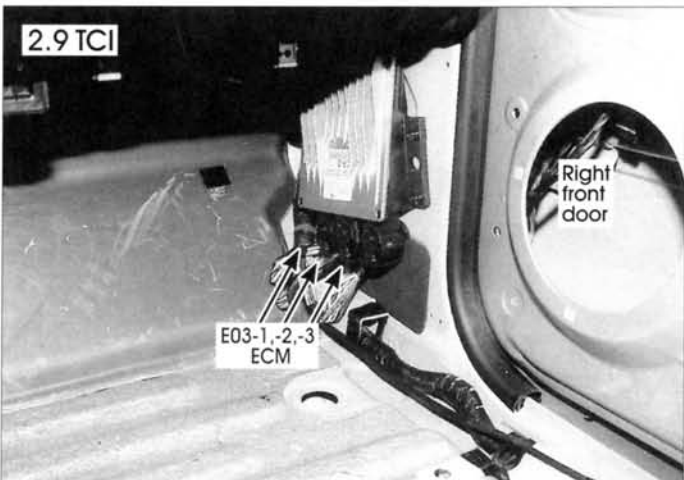

E03-1,E03-2,E03-3

E3ME002B

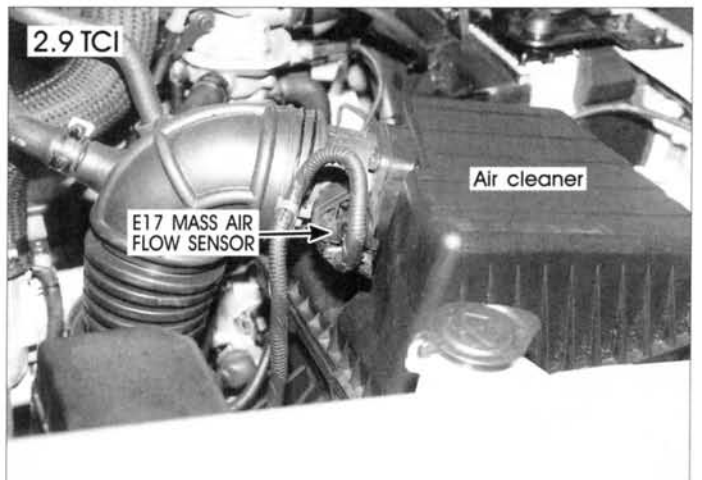

E17

E3ME002E

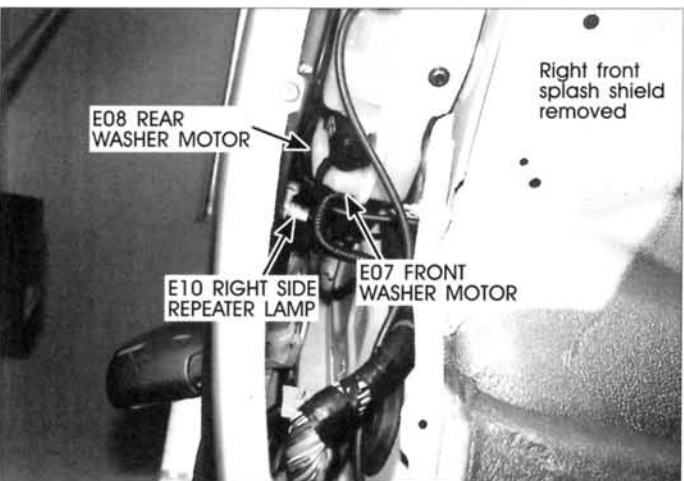

E07,E08,E10

E3ME002C



E18

E3ME002F

FRONT HARNESS(2)

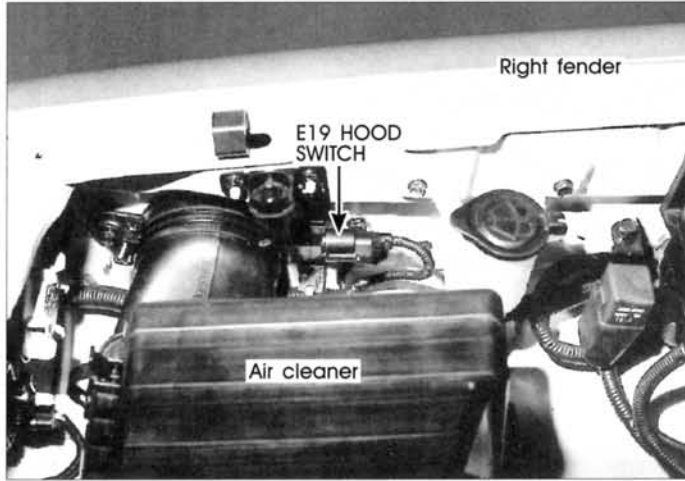

E19 E3ME002G

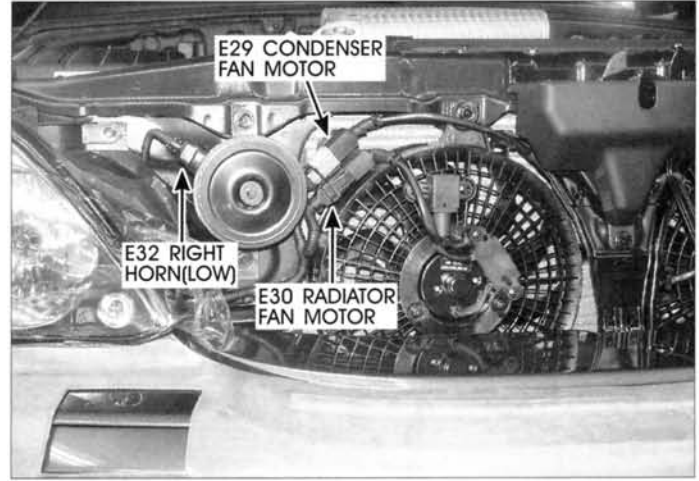

E29,E30,E32 E3ME002K

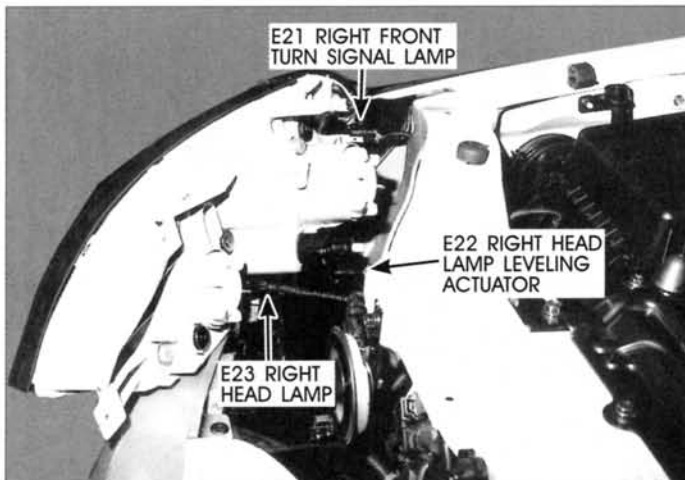

E21,E22,E23 E3ME002H

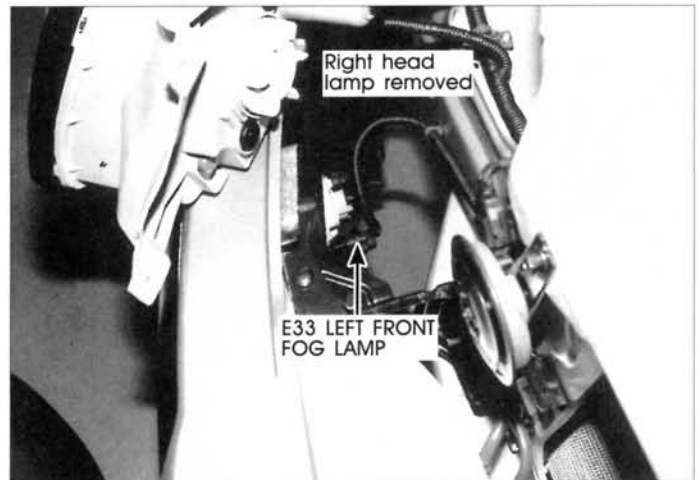

E33 E3ME002L

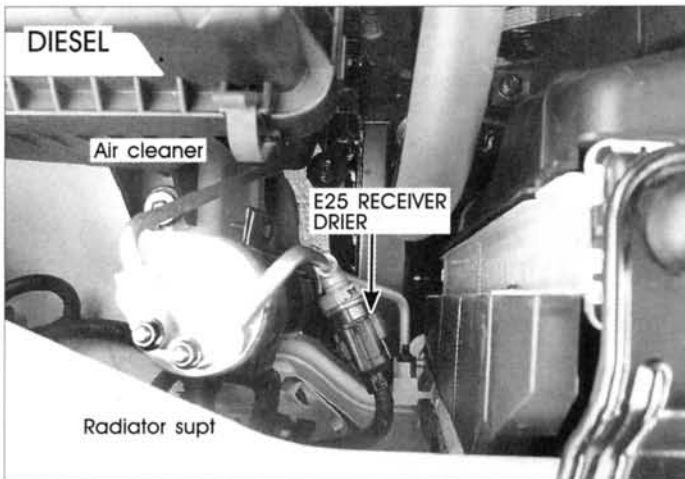

E25 E3ME002J

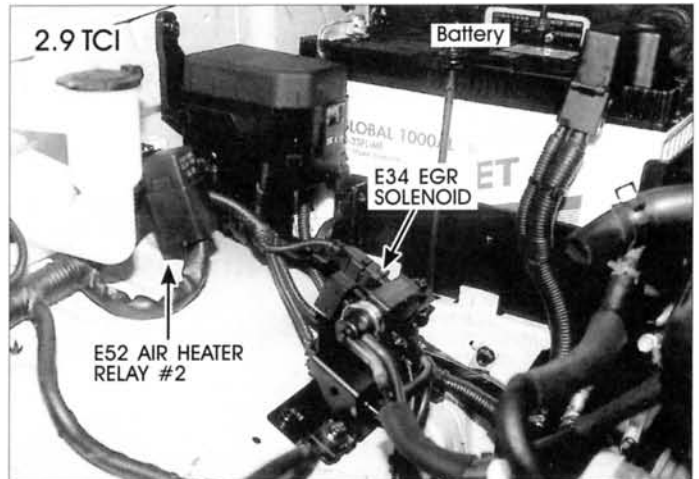

E34,E52 E3ME002M

FRONT HARNESS(3)

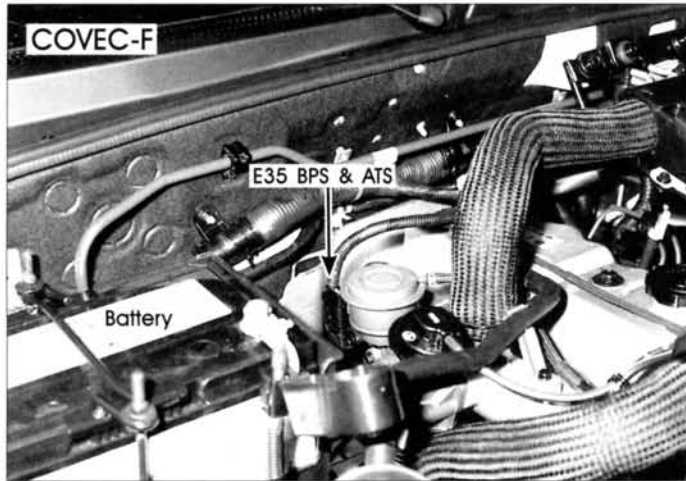

E35 E3ME002N

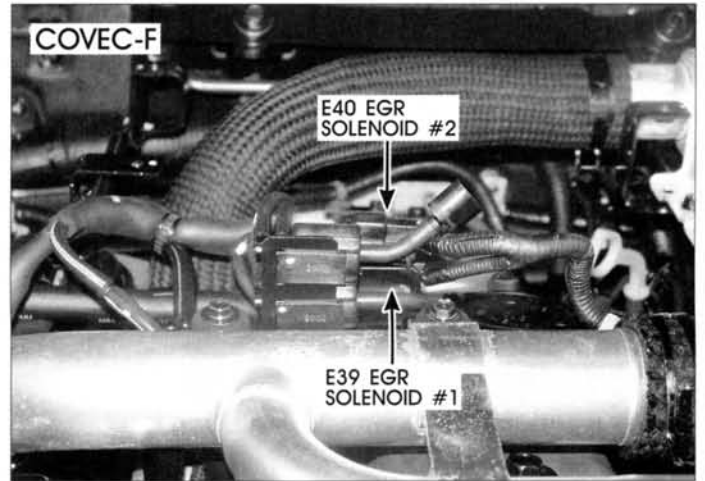

E39,E40 E3ME002R

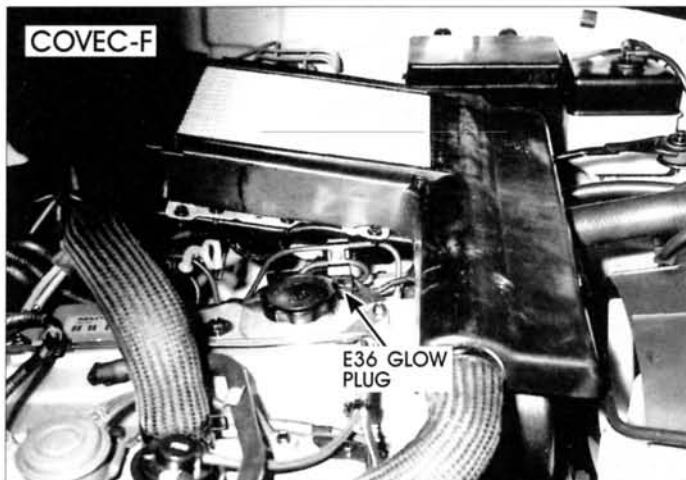

E36 E3ME002P

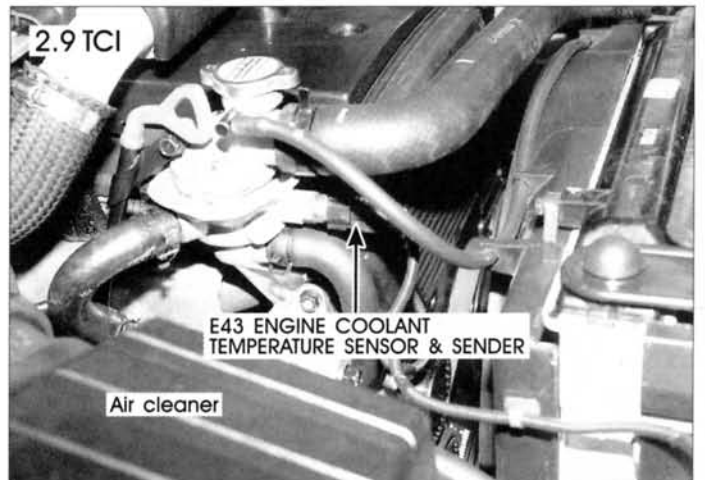

E43 E3ME002S

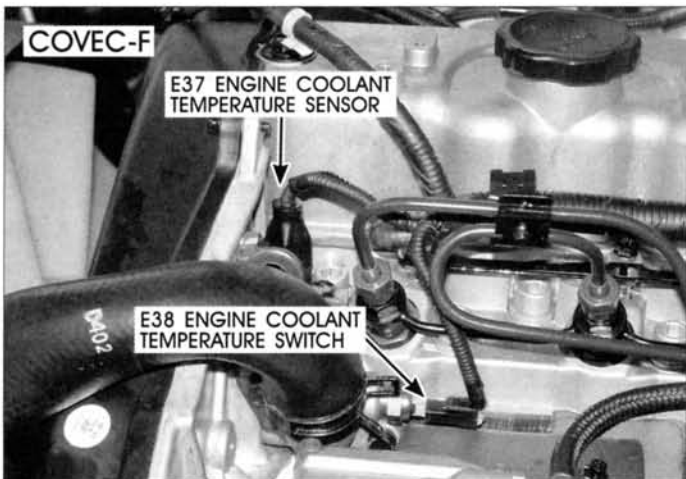

E37,E38 E3ME002Q

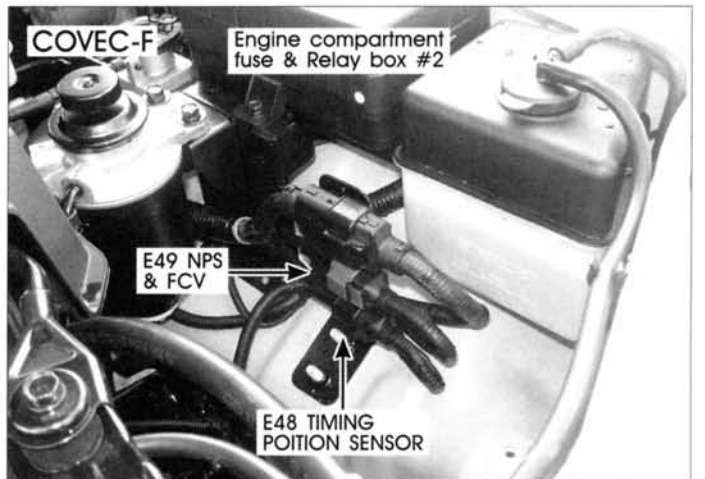

E48,E49 E3ME002T

FRONT HARNESS(4)

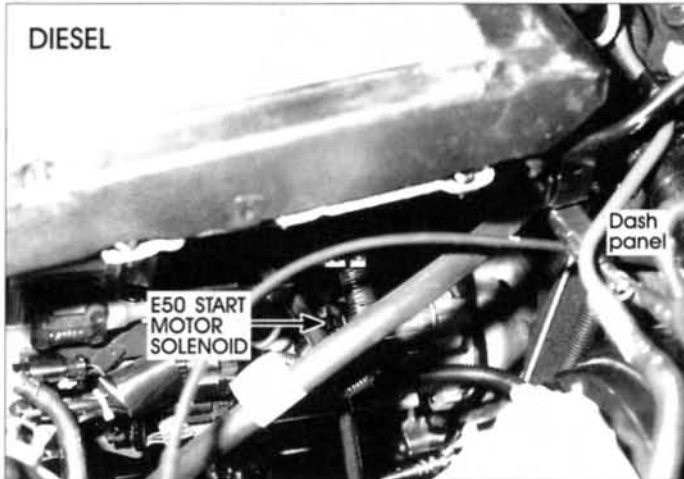

E50 E3ME002U

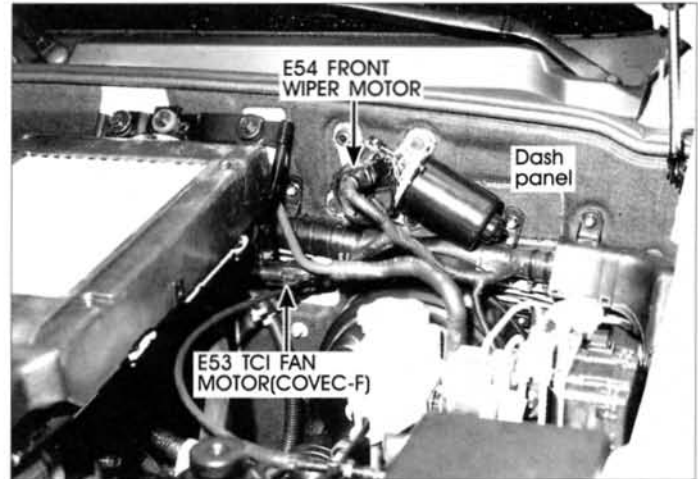

E53,E54 E3ME002X

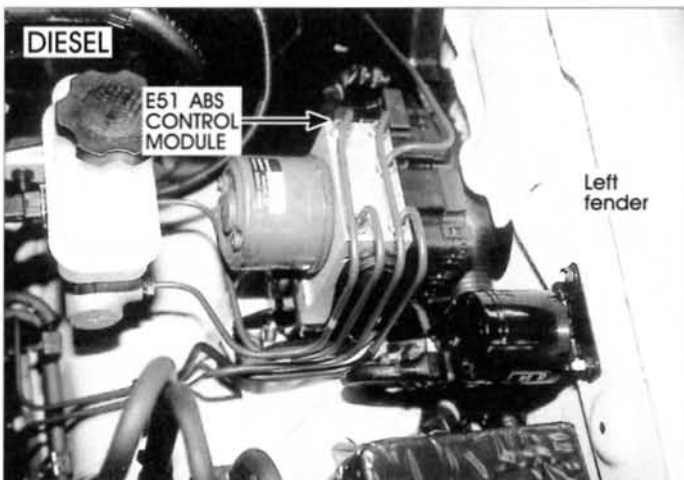

E51 E3ME002V

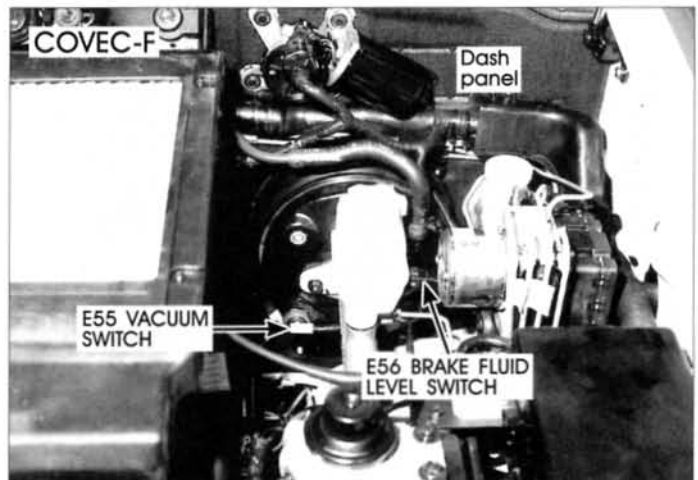

E55,E56 E3ME002Y

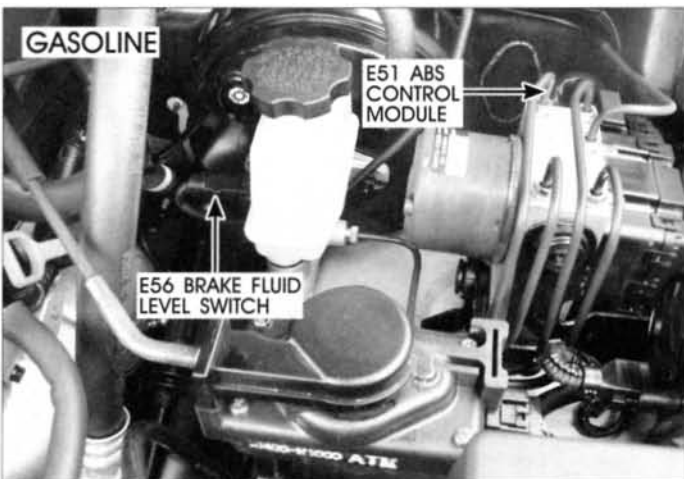

E51,E56 E3ME002W

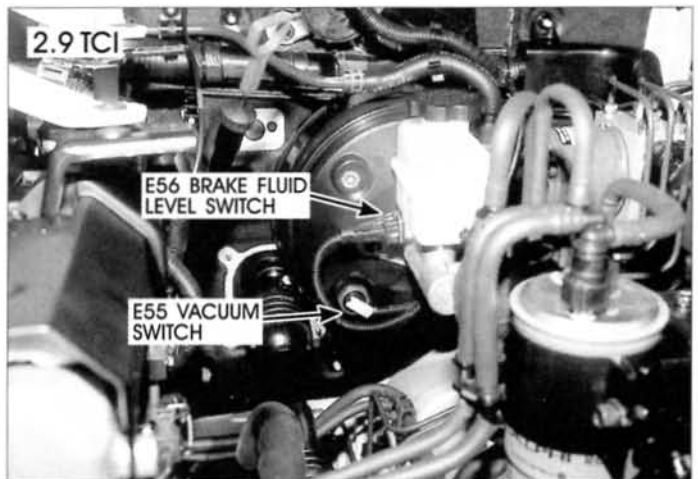

E55,E56 E3ME002Z

FRONT HARNESS(5)

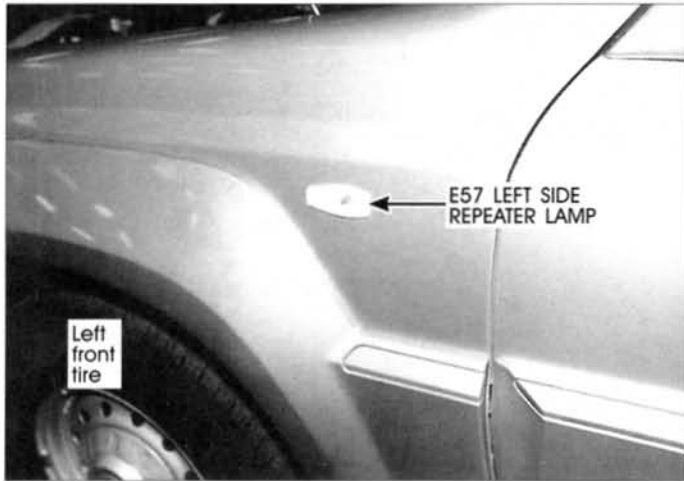

E57 E3ME0A2A

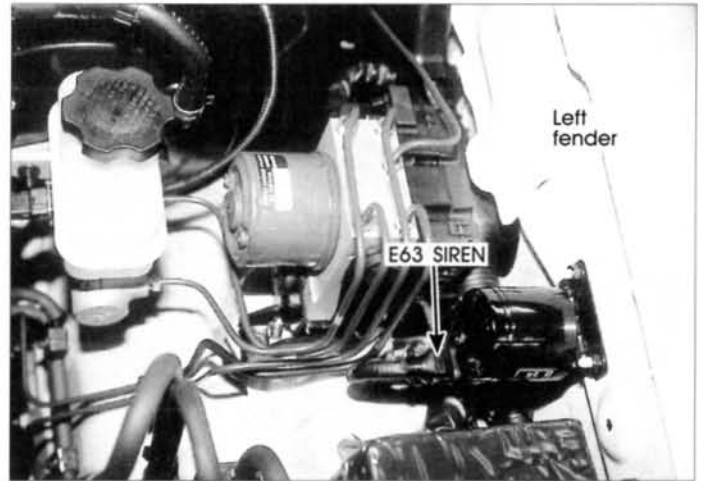

E63 E3ME0A2D

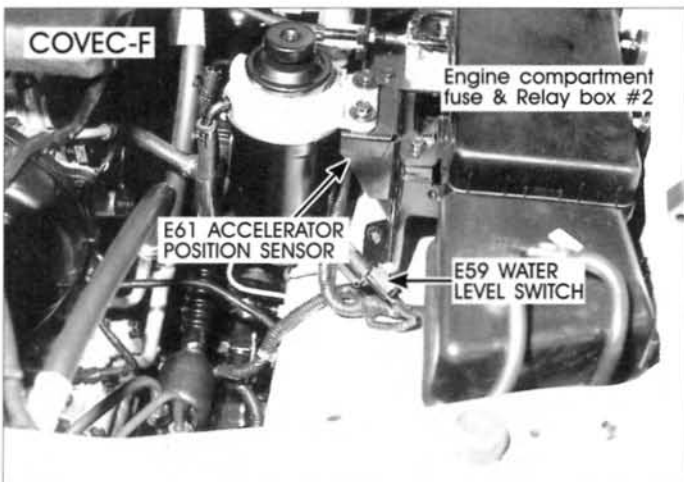

E59,E61 E3ME0A2B

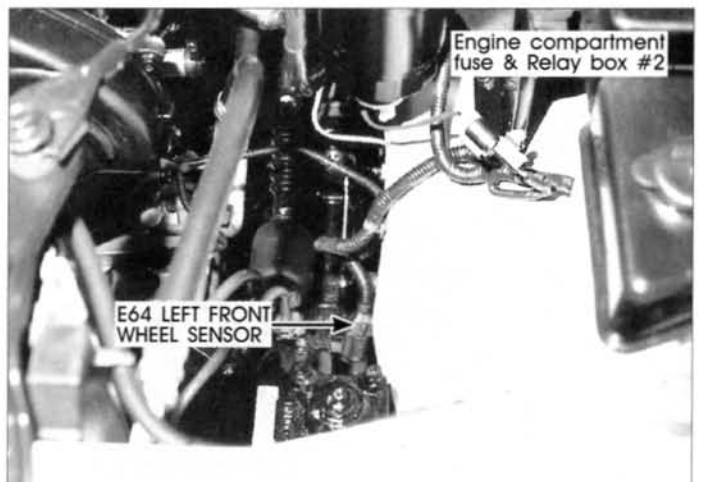

E64 E3ME0A2E

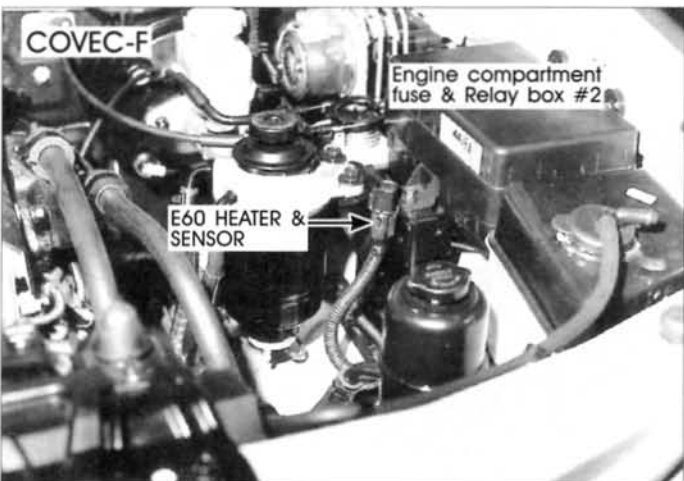

E60 E3ME0A2C

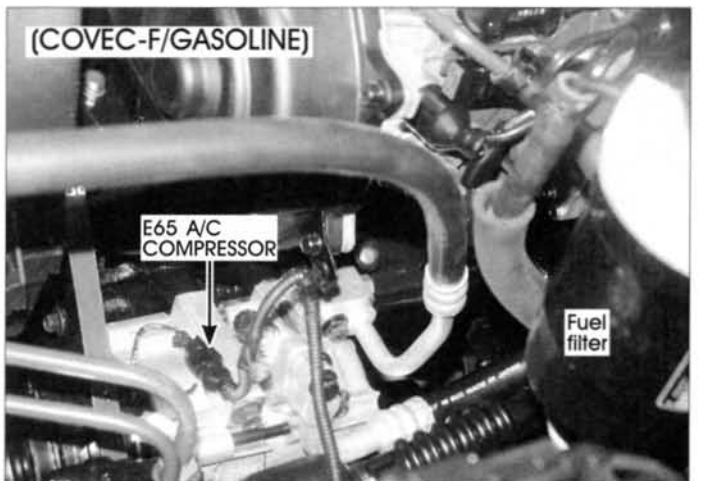

E65 E3ME0A2F

FRONT HARNESS(6)

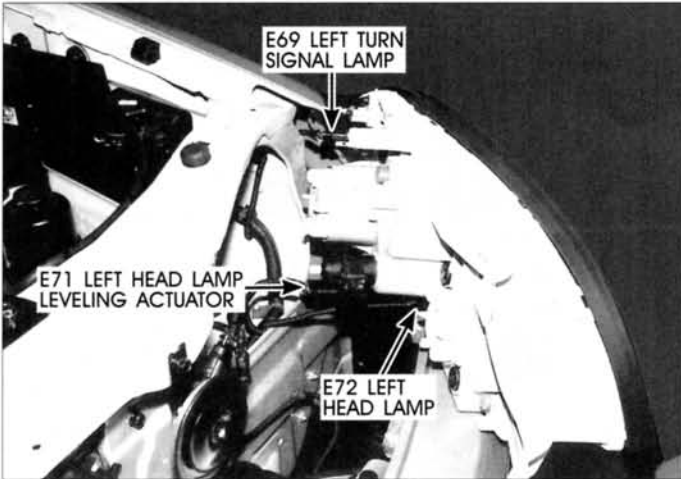

E69,E71,E72

E3ME0A2G



E77

E3ME0A2K

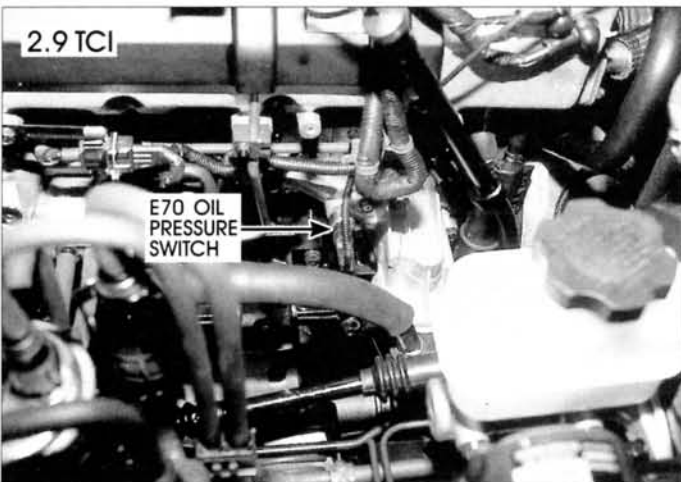

E70

E3ME0A2H

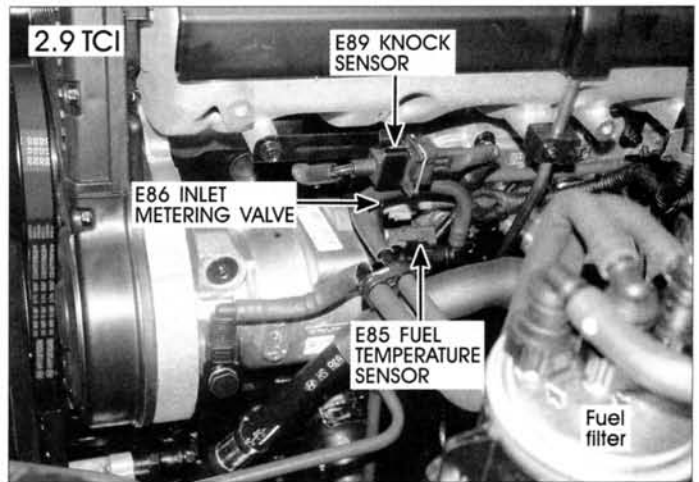

E85,E86,E89

E3ME0A2L

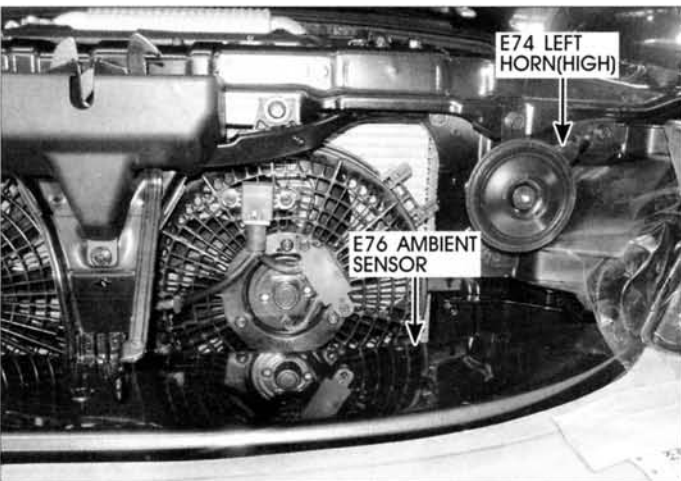

E74,E76

E3ME0A2J

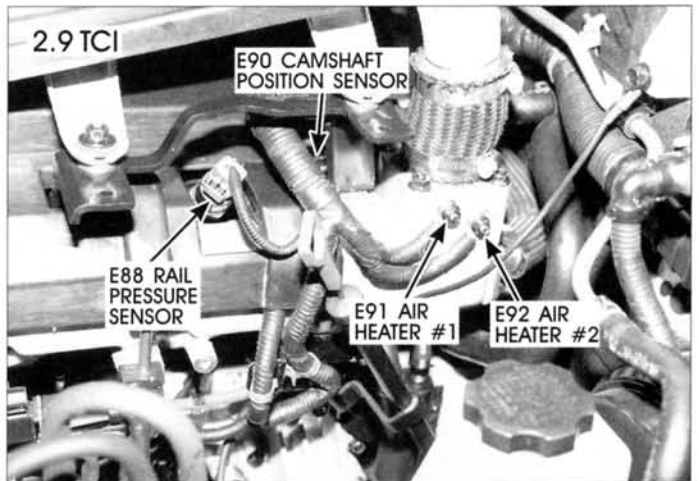

E88,E90,E91,E92

E3ME0A2M

FRONT HARNESS(7)

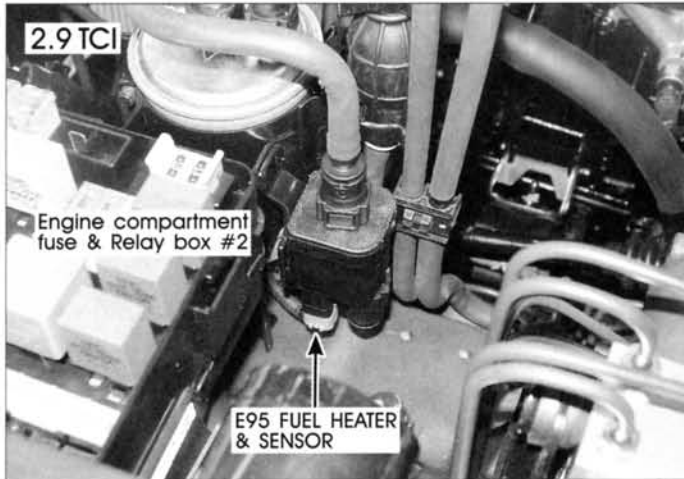

E95

E3ME0A2N

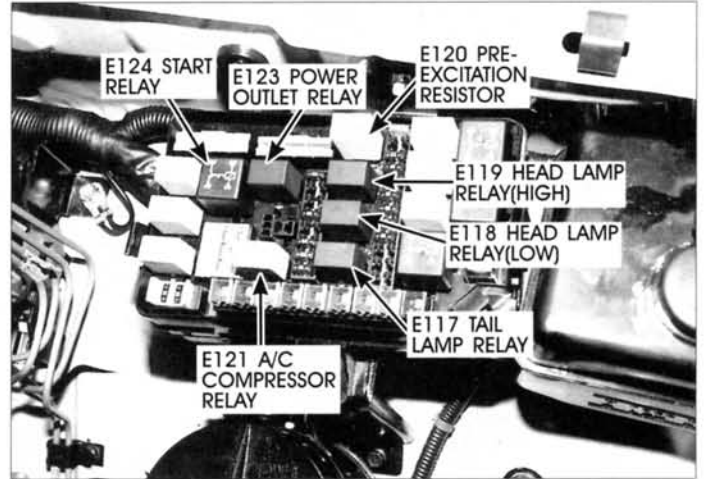

E117,E118,E119,E120,E121,E123,E124

E3ME0A2R



E96

E3ME0A2P

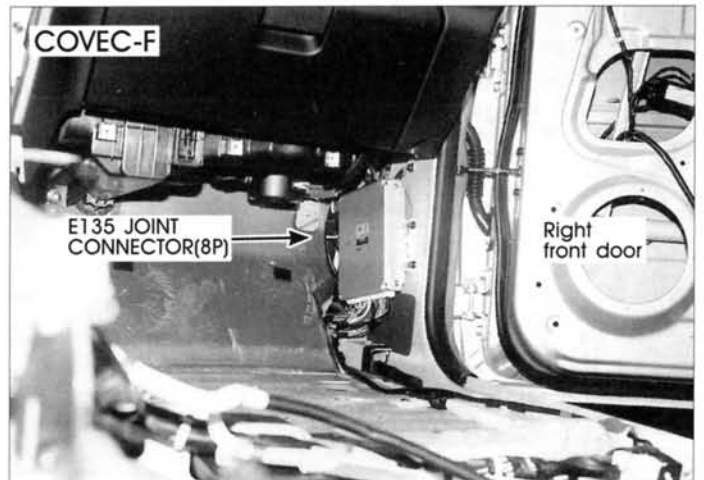

E135

E3ME0A2S

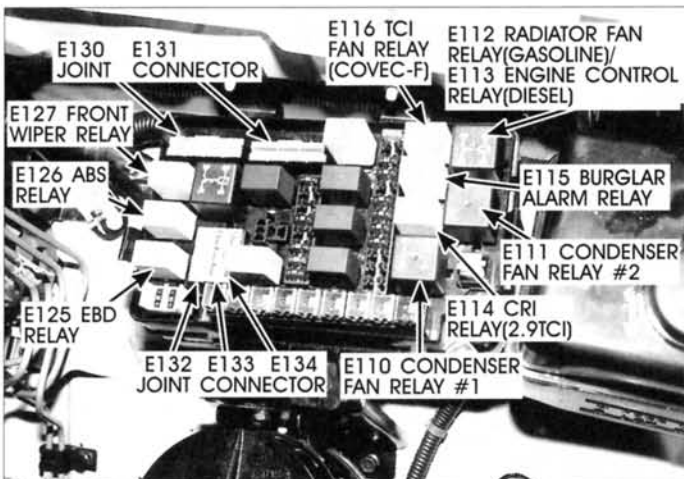

E110,E111,E112,E113,E114,E115,E116
E125,E126,E127,E130,E131,E132,E133,E134

E3ME0A2Q

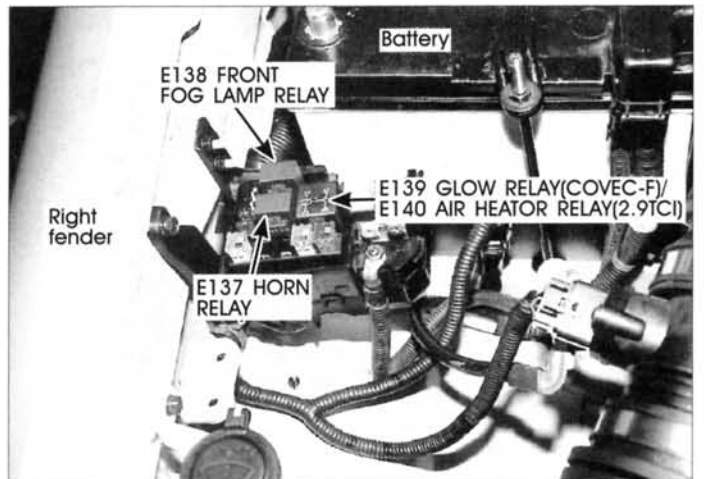

E137,E138,E139,E140

E3ME0A2T

FRONT HARNESS(8)

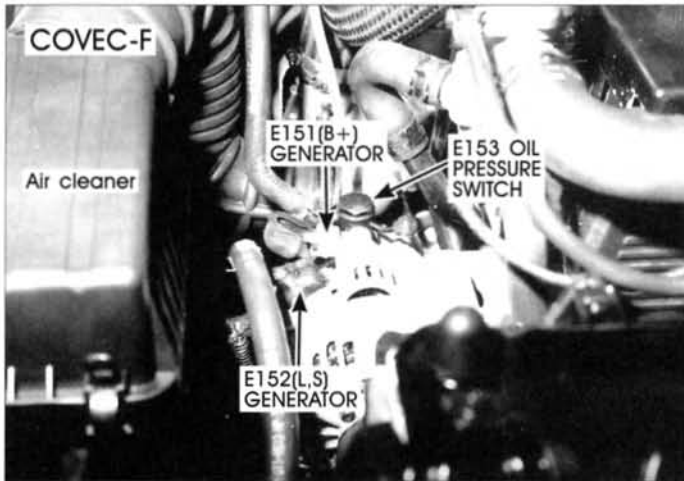

E151,E152,E153

E3ME0A2U

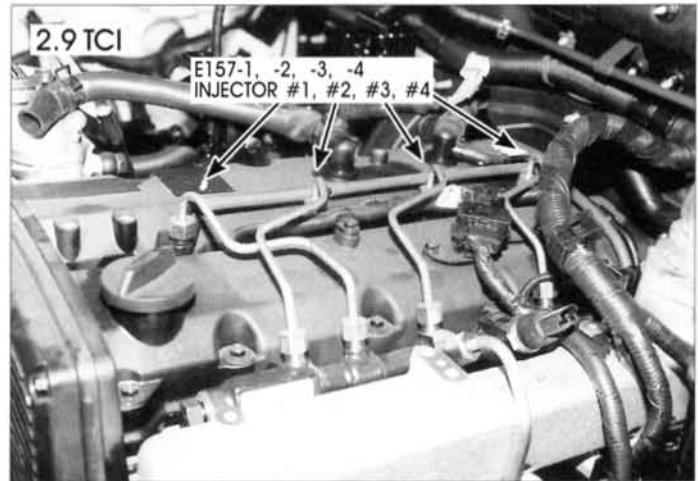

E157-1,E157-2,E157-3,E157-4

E3ME0A2X

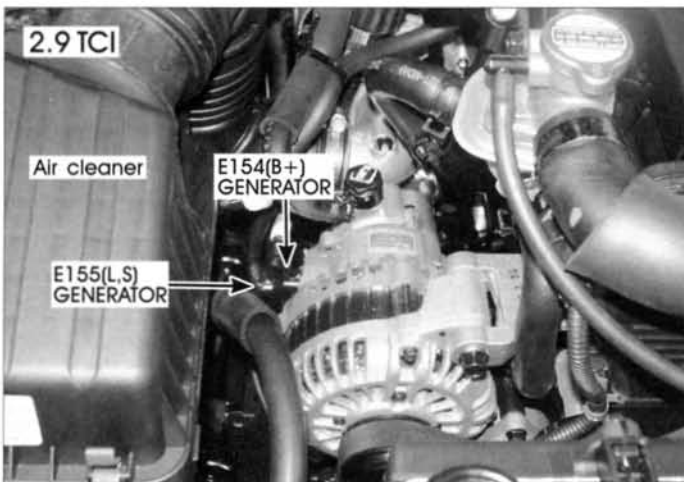

E154,E155

E3ME0A2V

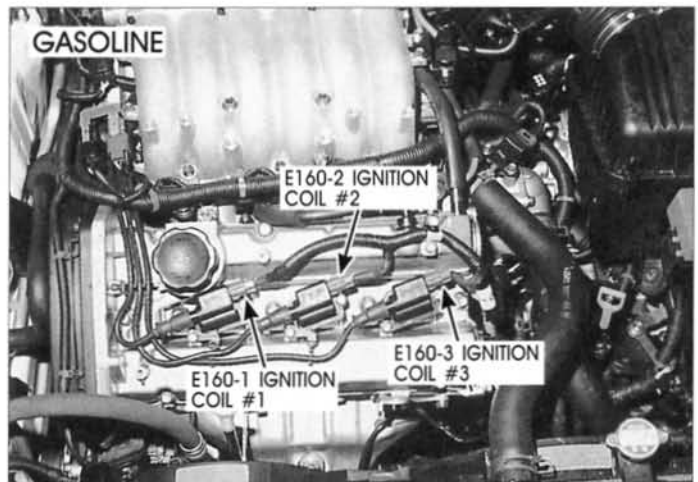

E160-1,E160-2,E160-3

E3ME0A2Y

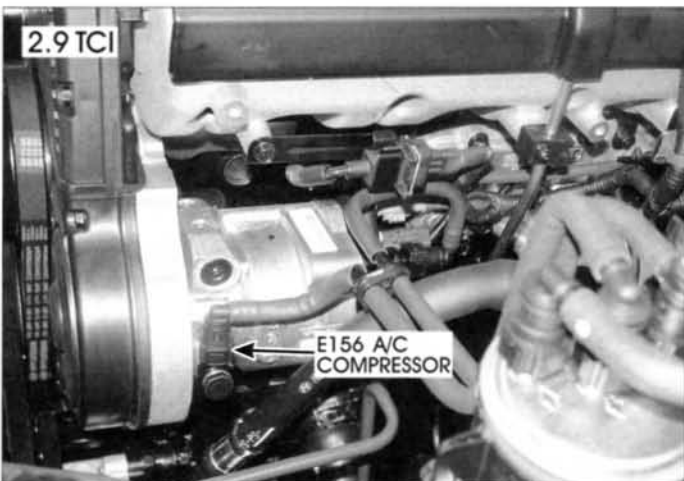

E156

E3ME0A2W

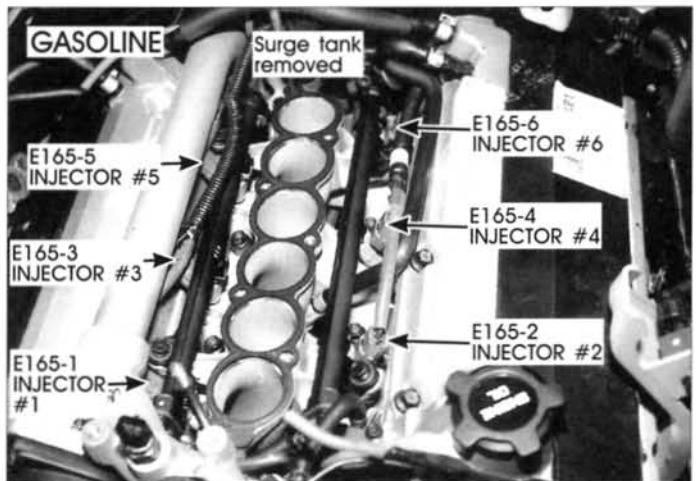

E165-1,E165-2,E165-3
E165-4,E165-5,E165-6

E3ME0A2Z

FRONT HARNESS(9)

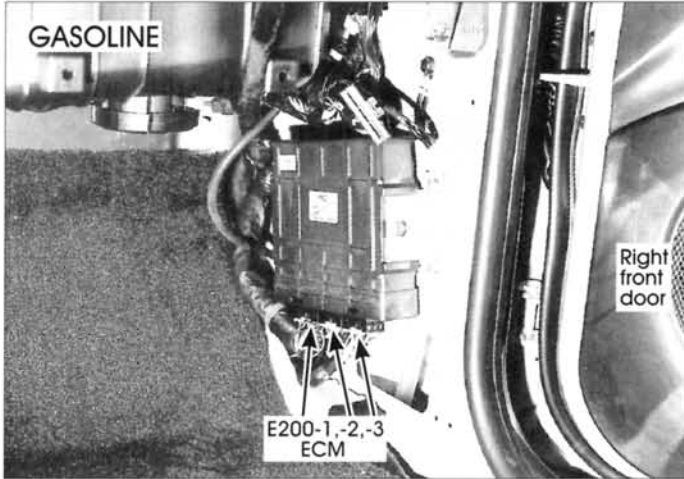

E200-1, E200-2, E200-3

E3ME0B2A

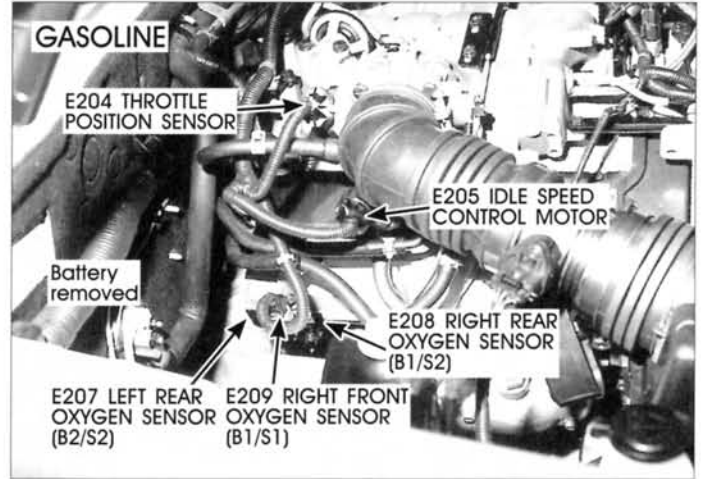

E204, E205, E207, E208, E209

E3ME0B2D

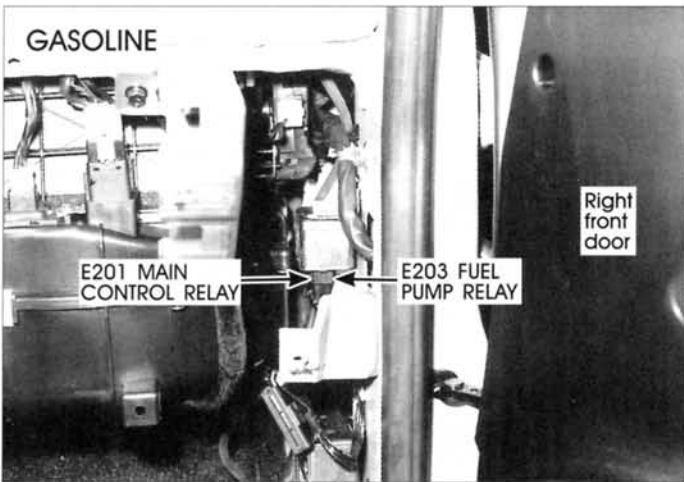

E201, E203

E3ME0B2B

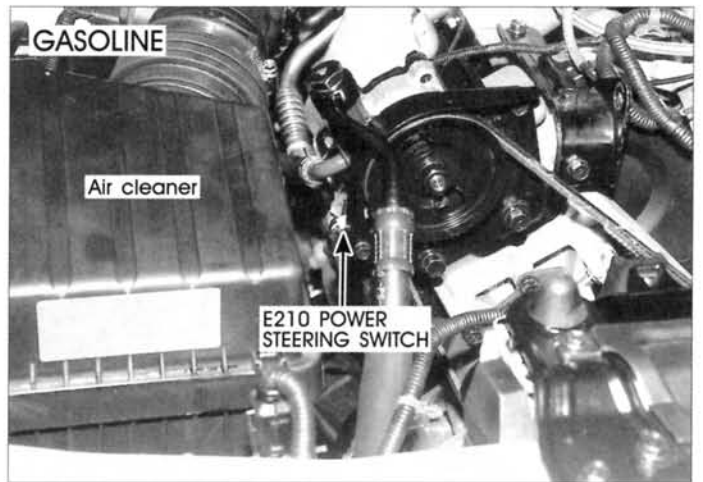

E210

E3ME0B2E

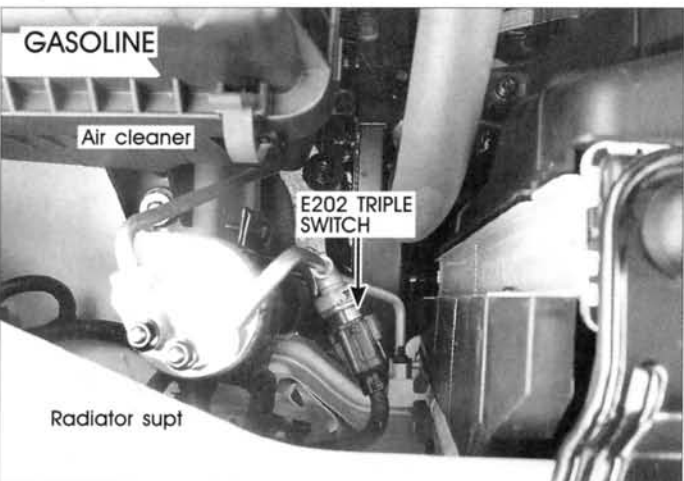

E202

E3ME0B2C

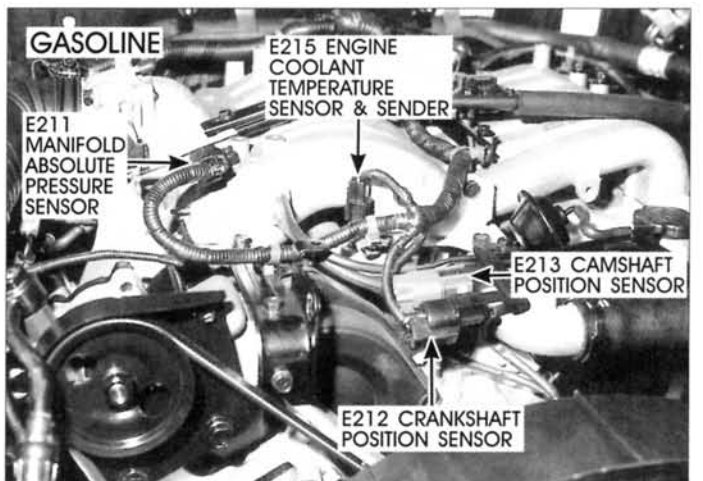

E211, E212, E213, E215

E3ME0B2F

FRONT HARNESS(10)

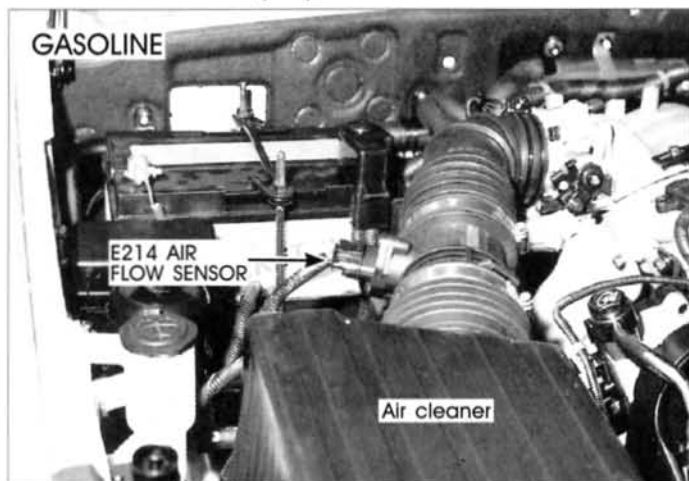

E214

E3ME0B2G

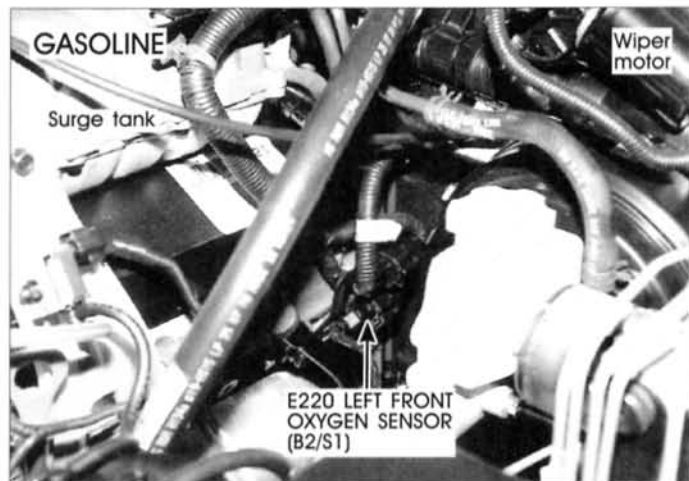

E220

E3ME0B2K

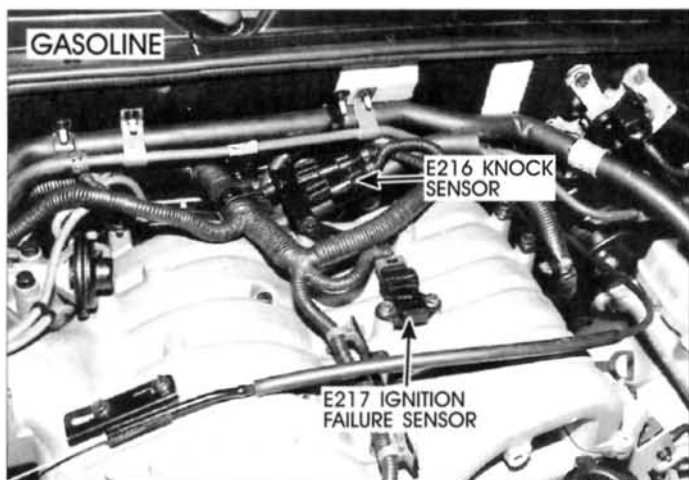

E216,E217

E3ME0B2H

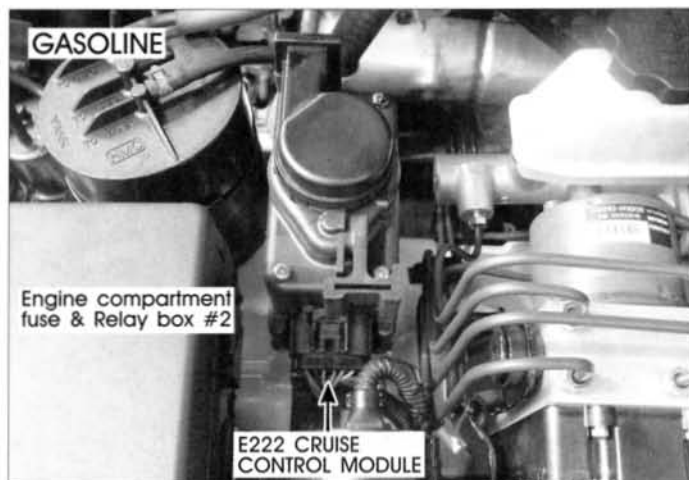

E222

E3ME0B2L

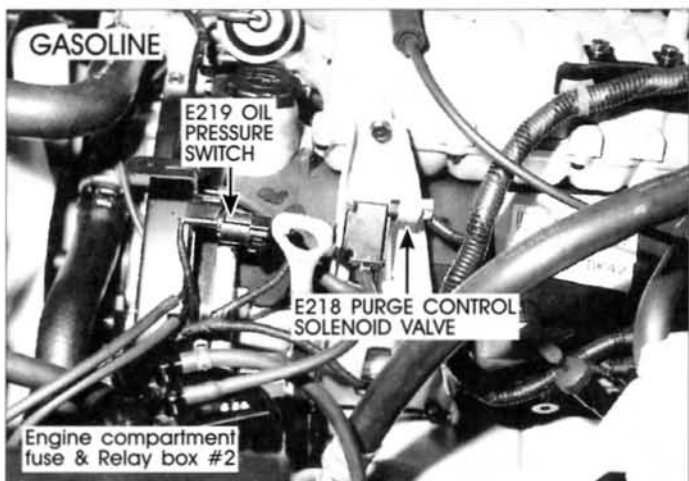

E218,E219

E3ME0B2J

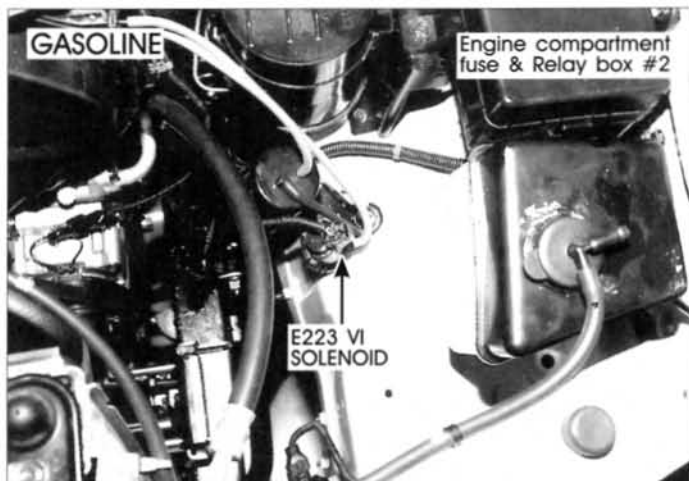

E223

E3ME0B2M

FRONT HARNESS(11)

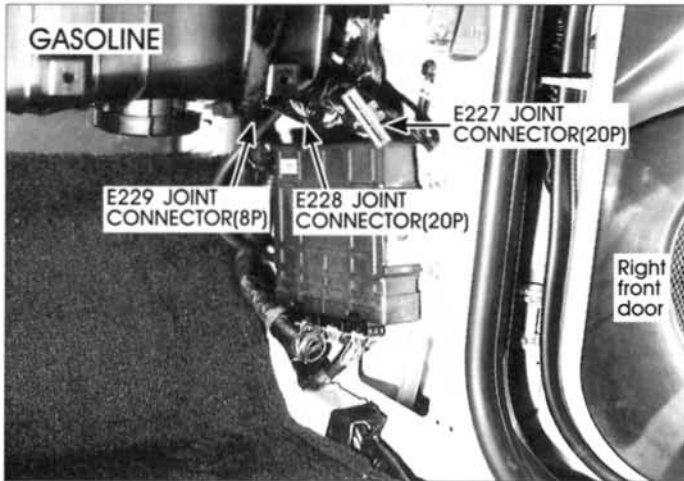

E227,E228,E229

E3ME0B2N

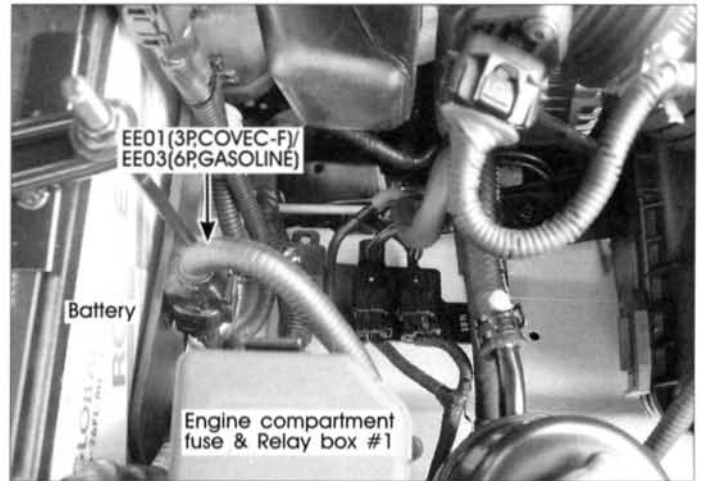

EE01,EE03

E3ME0B2R

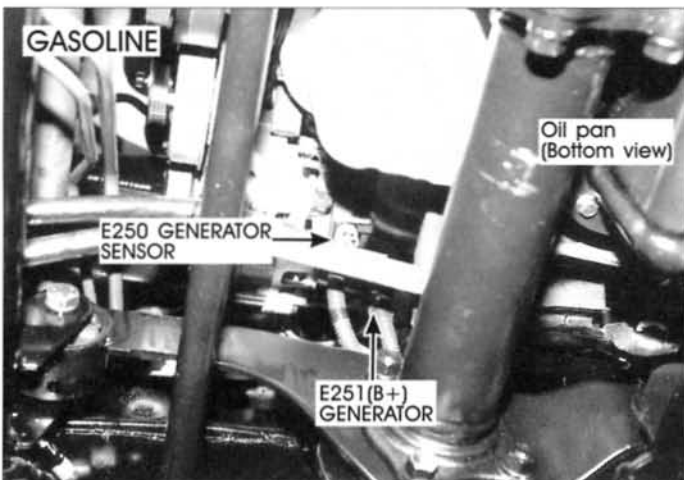

E250,E251

E3ME0B2P

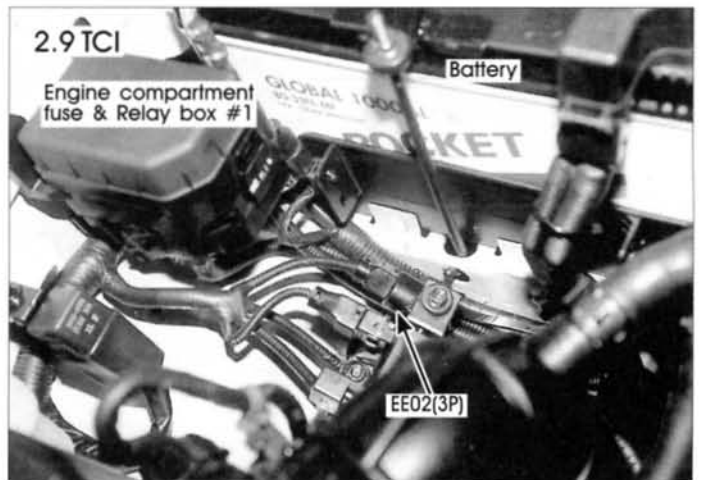

EE02

E3ME0B2S

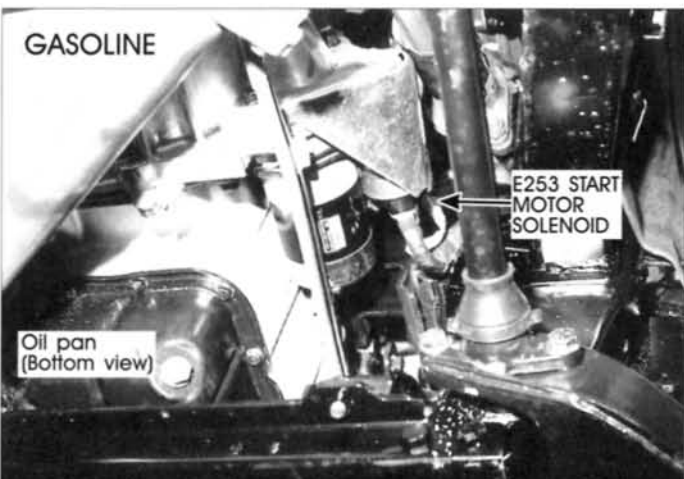

E253

E3ME0B2Q

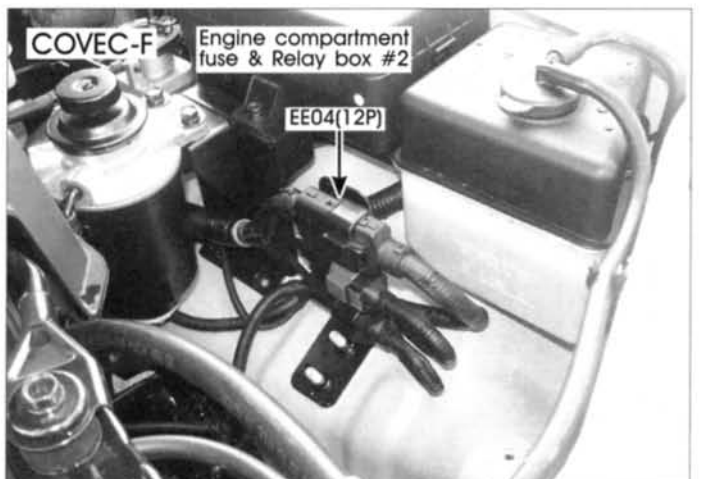

EE04

E3ME0B2T

FRONT HARNESS(12)

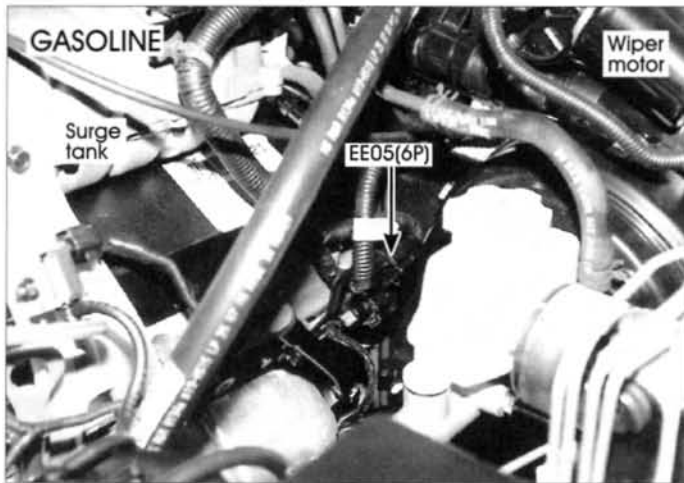

EE05

E3ME082U

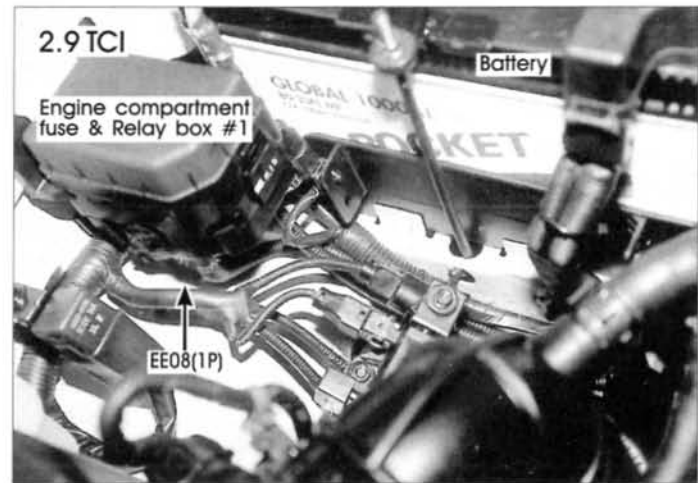

EE08

E3ME082X

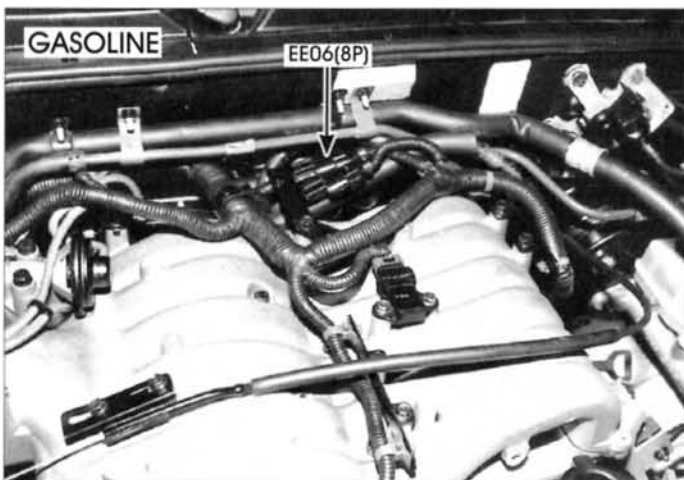

EE06

E3ME082V

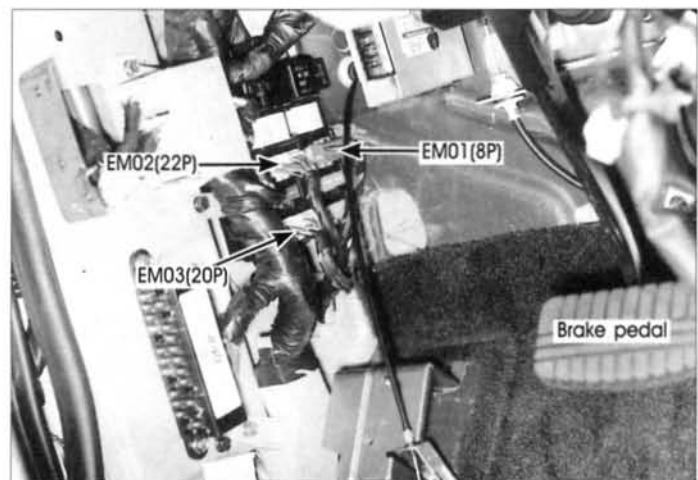

EM01,EM02,EM03

E3ME082Y

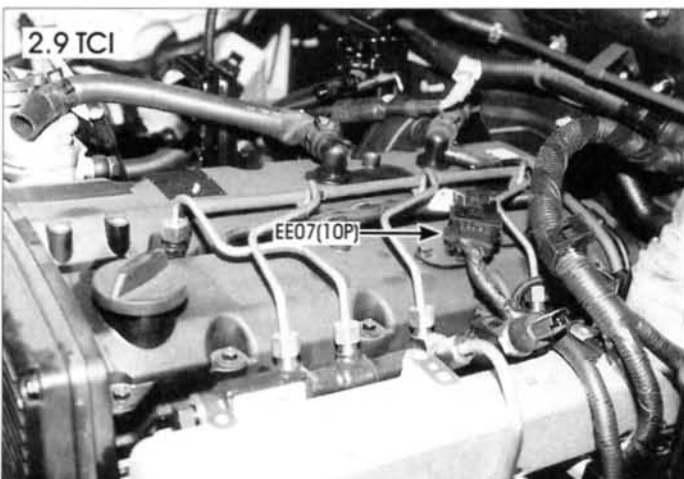

EE07

E3ME082W

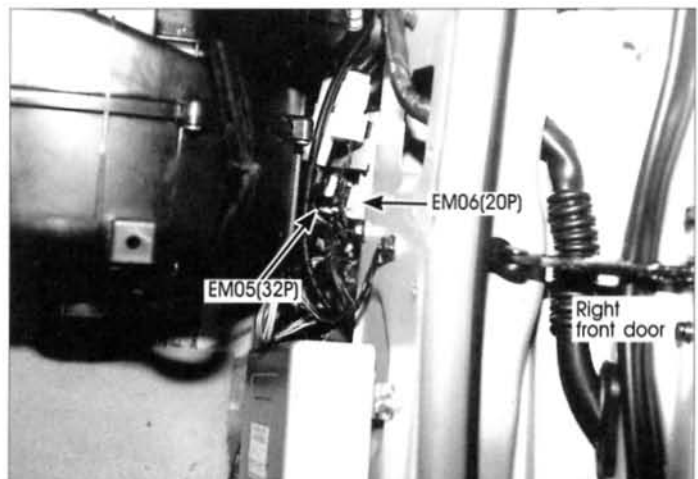

EM05,EM06

E3ME082Z

INSTRUMENT HARNESS

INSTRUMENT HARNESS(1)

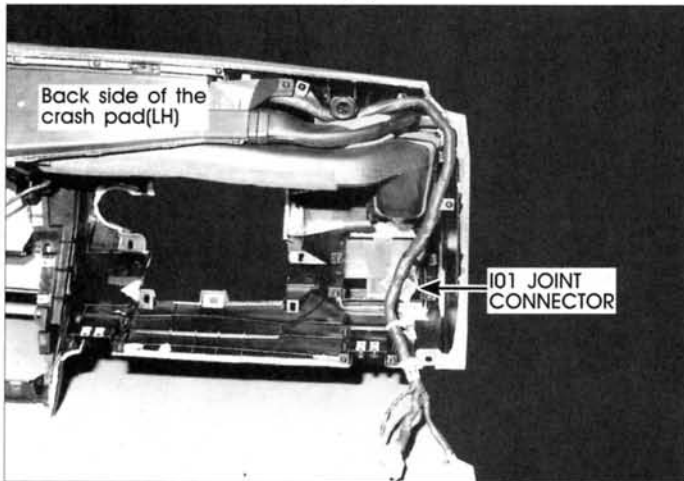

I01

E3ME003A

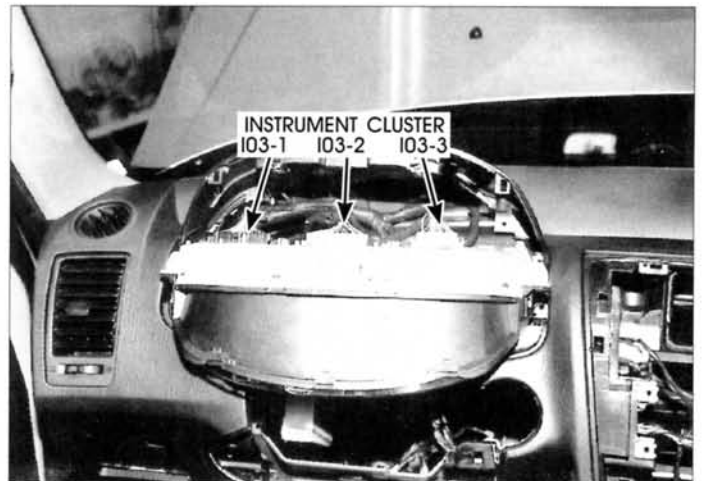

I03-1,I03-2,I03-3

E3ME003C

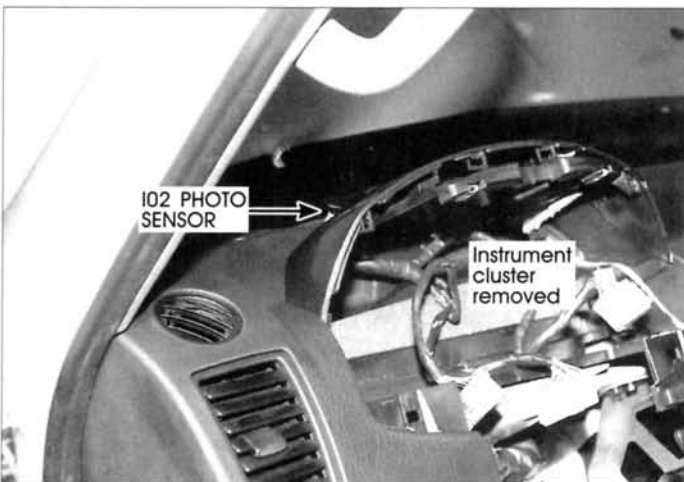

I02

E3ME003B

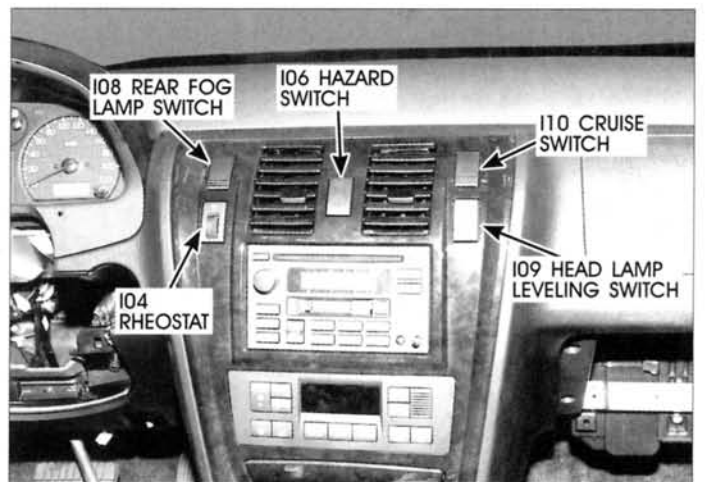

I04,I06,I08,I09,I10

E3ME003D

T/M HARNESS

T/M HARNESS(1)

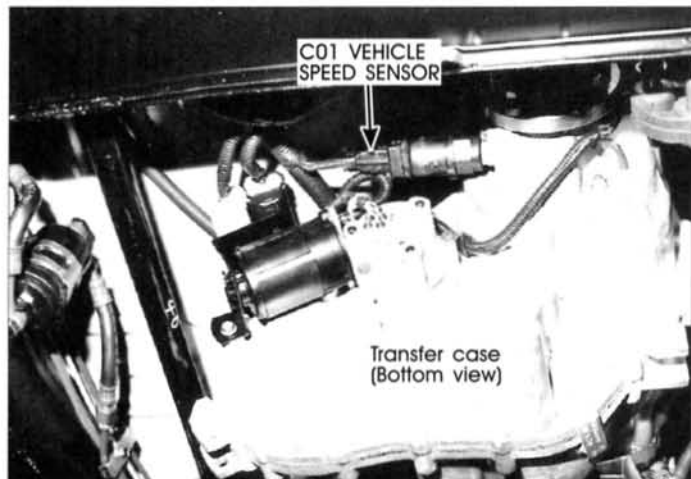

C01

E3ME004A

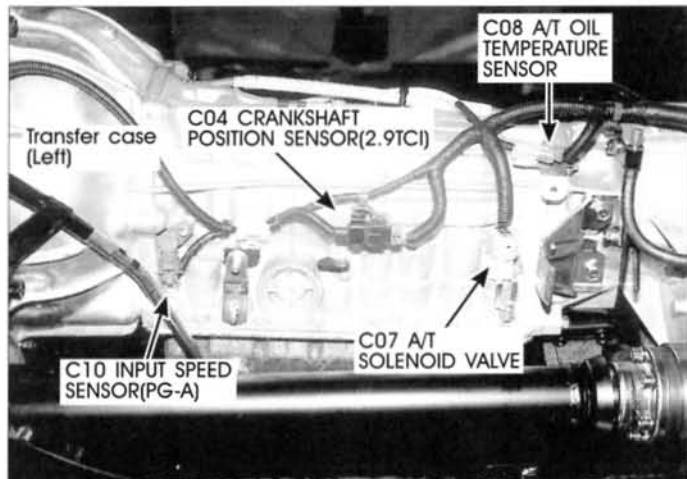

C04,C07,C08,C10

E3ME004D

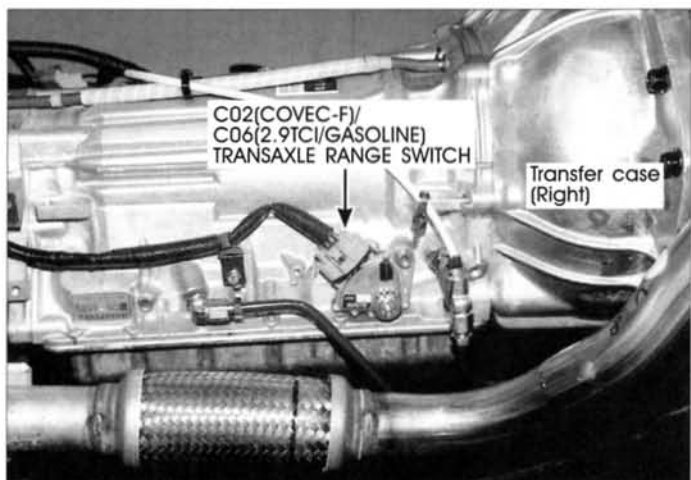

C02,C06

E3ME004B

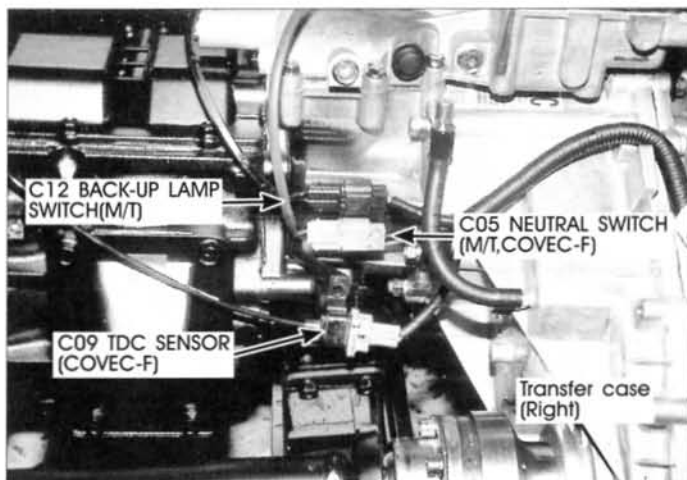

C05,C09,C12

E3ME004E

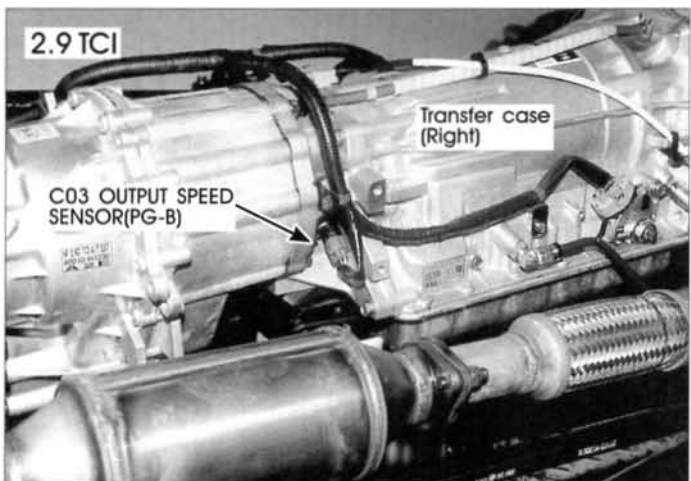

C03

E3ME004C

DOOR HARNESS

DOOR HARNESS(1)

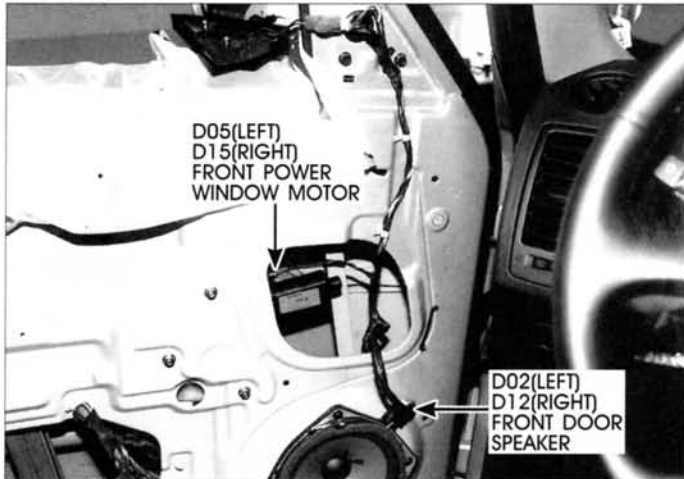

D02,D05,D12,D15

E3ME005A

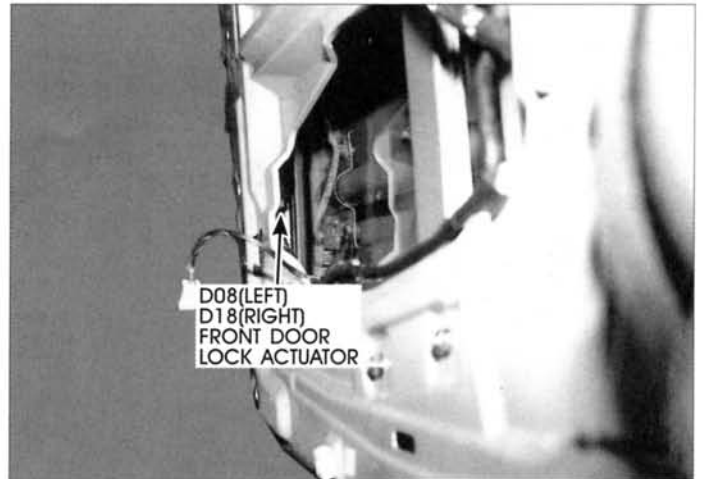

D08,D18

E3ME005D

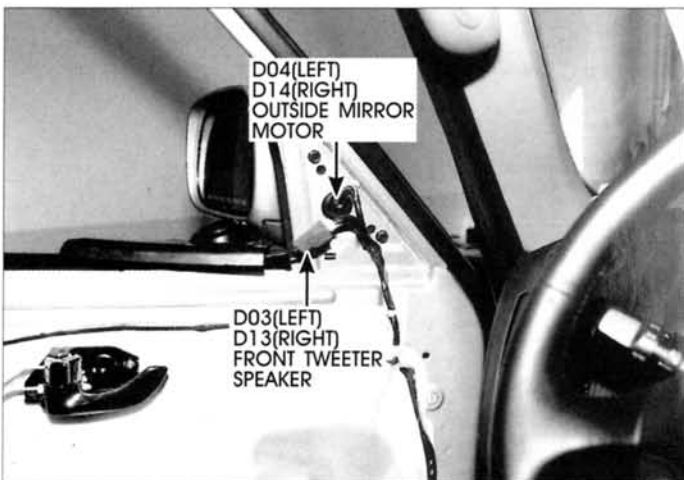

D03,D04,D13,D14

E3ME005B

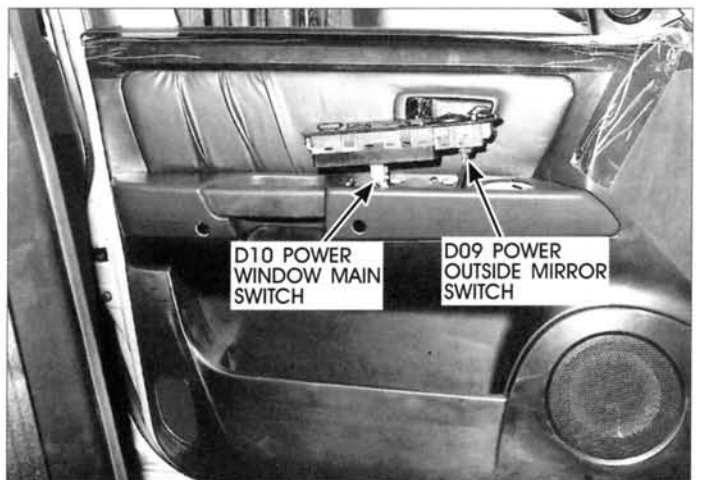

D09,D10

E3ME005E

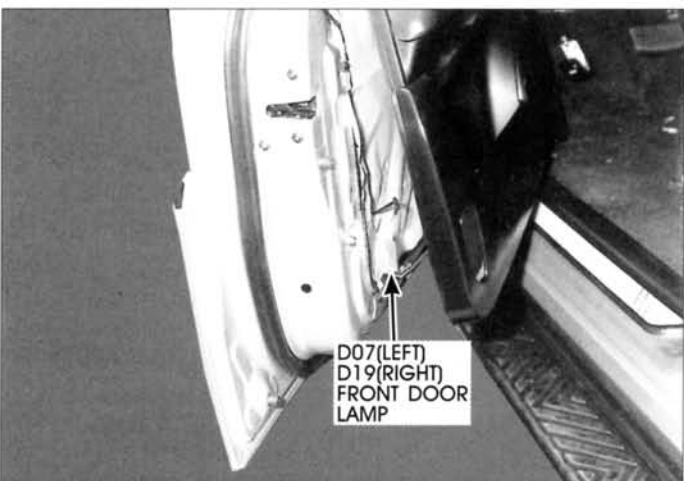

D07,D19

E3ME005C



D17

E3ME005F

DOOR HARNESS(2)

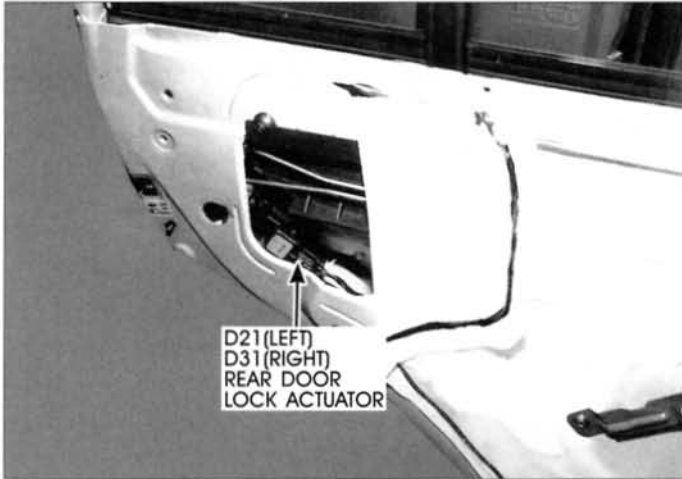

D21,D31

E3ME005G



D24,D34

E3ME005J

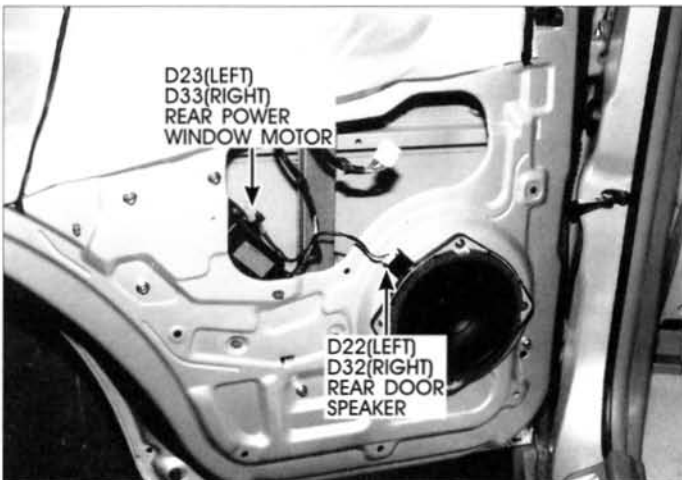

D22,D23,D32,D33

E3ME005H

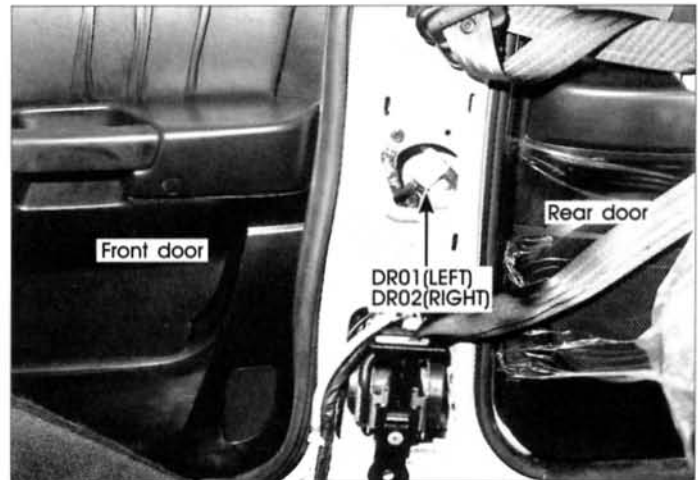

DR01,DR02

E3ME005K

REAR HARNESS

REAR HARNESS(1)

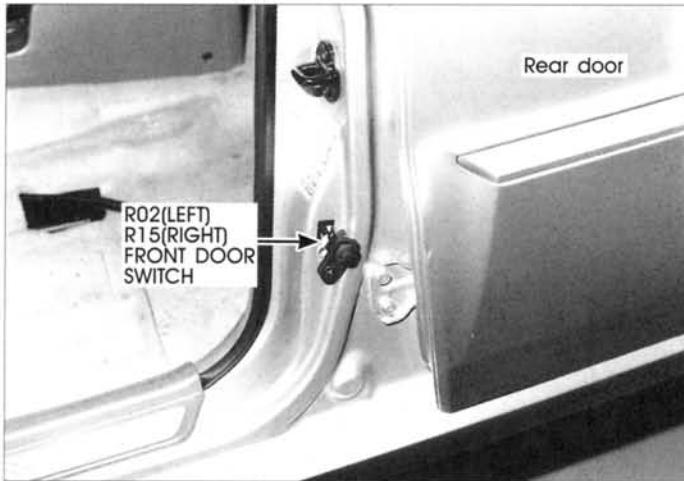

R02,R15

E3ME006A

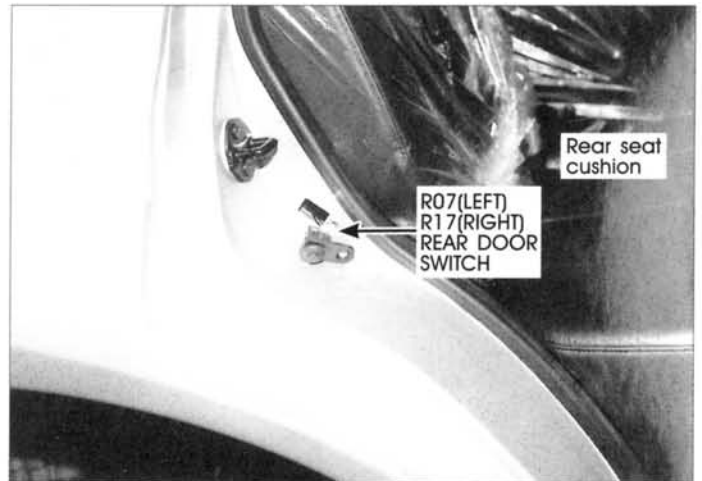

R07,R17

E3ME006D

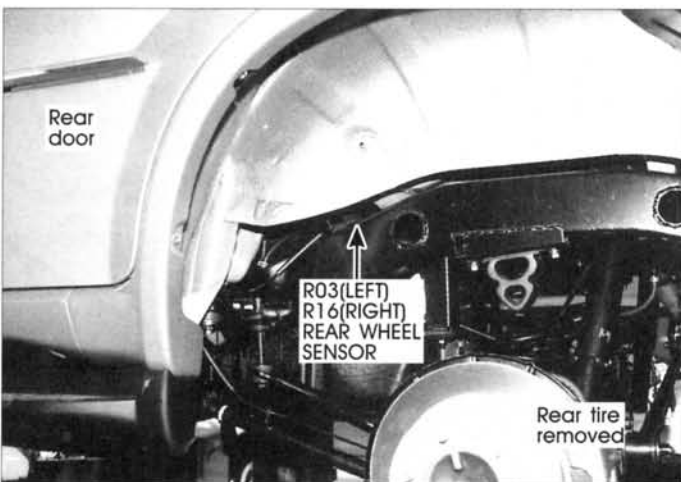

R03,R16

E3ME006B

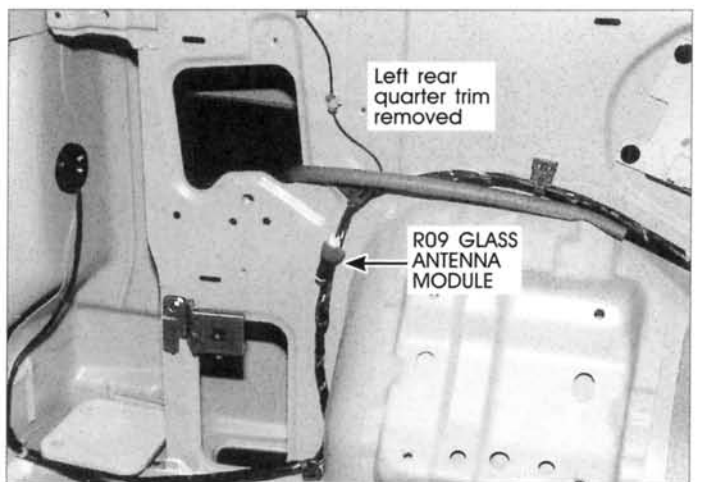

R09

E3ME006E

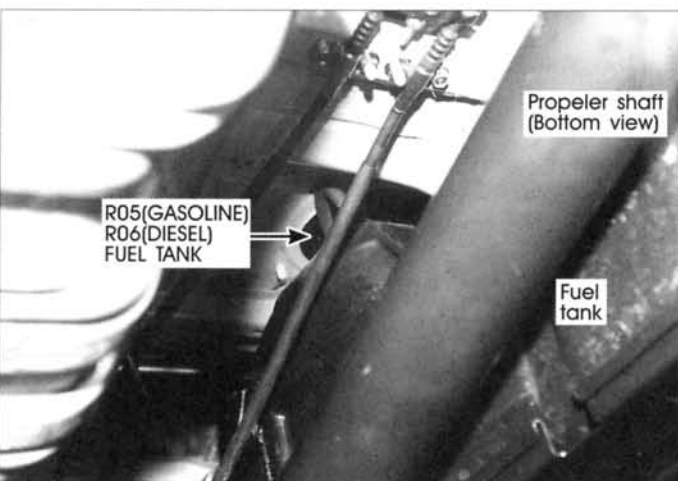

R05,R06

E3ME006C

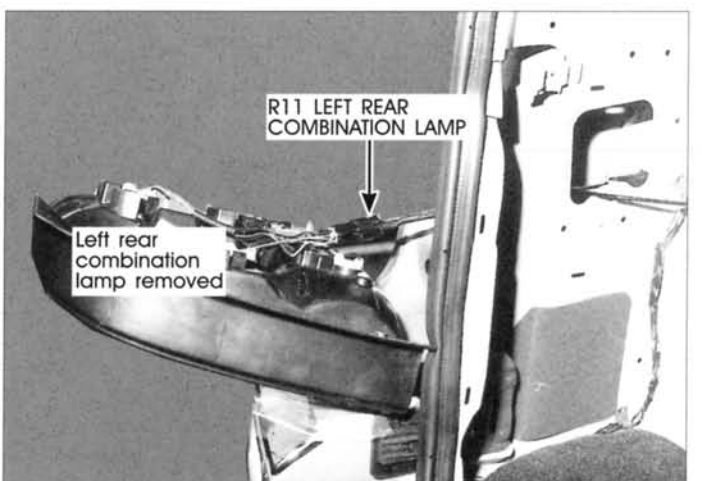

R11

E3ME006F

REAR HARNESS(2)

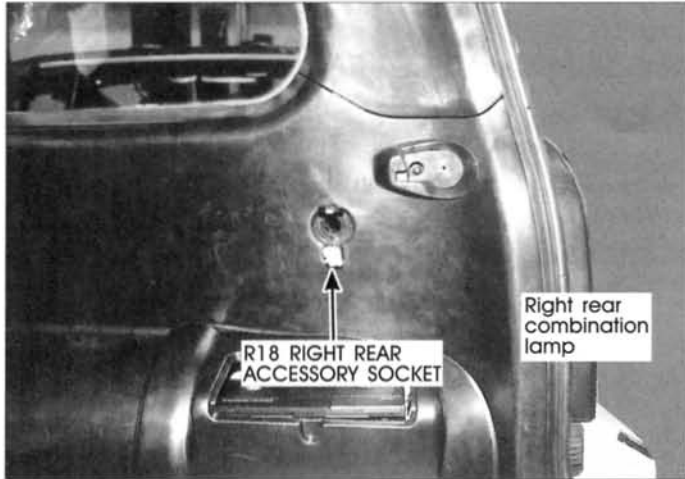

R18 E3ME006G

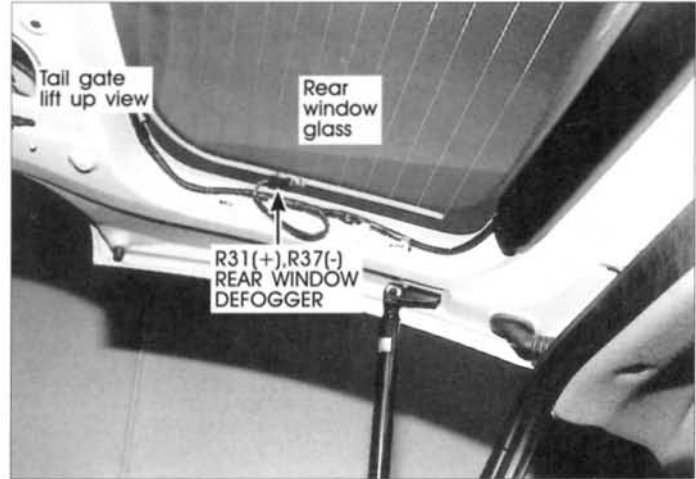

R31, R37 E3ME006K

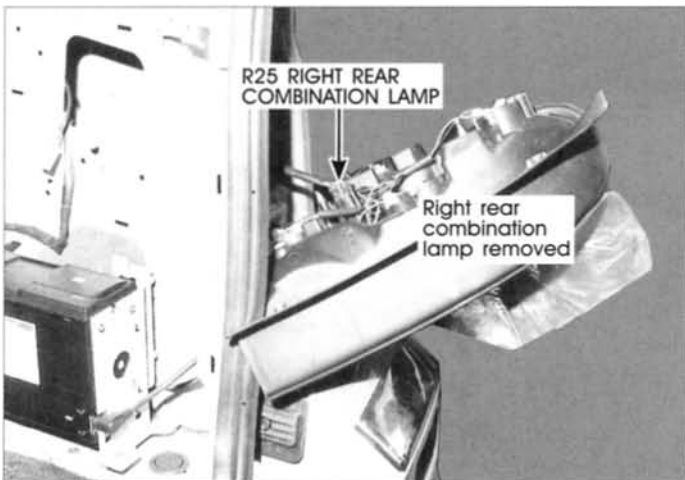

R25 E3ME006H

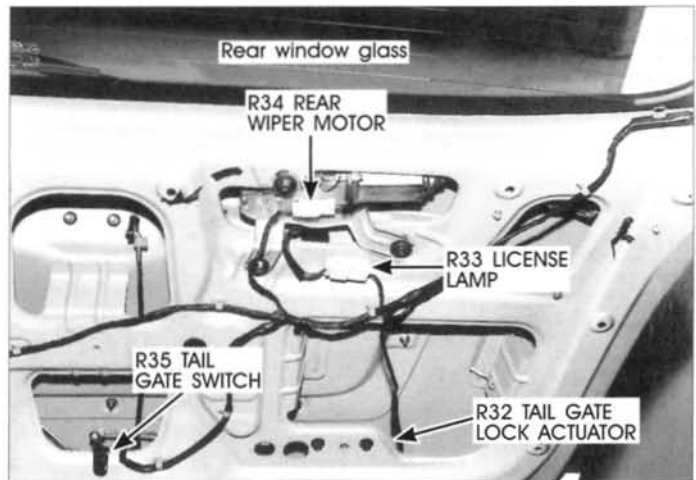

R32, R33, R34, R35 E3ME006L



R30 E3ME006J



R40 E3ME006M

REAR HARNESS(3)

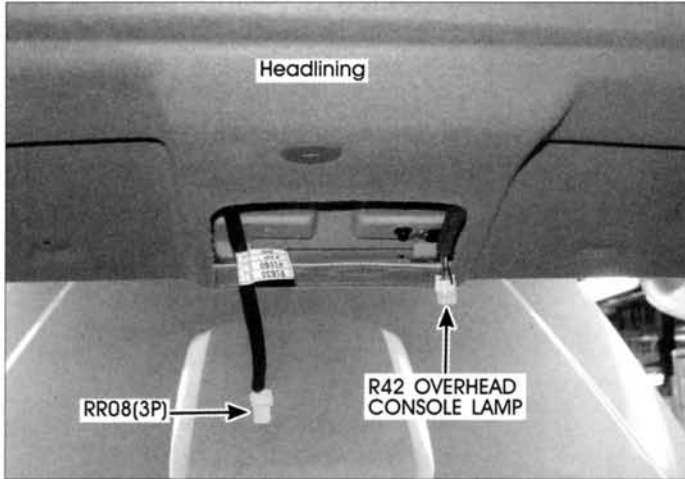

R42,RR08

E3ME006N

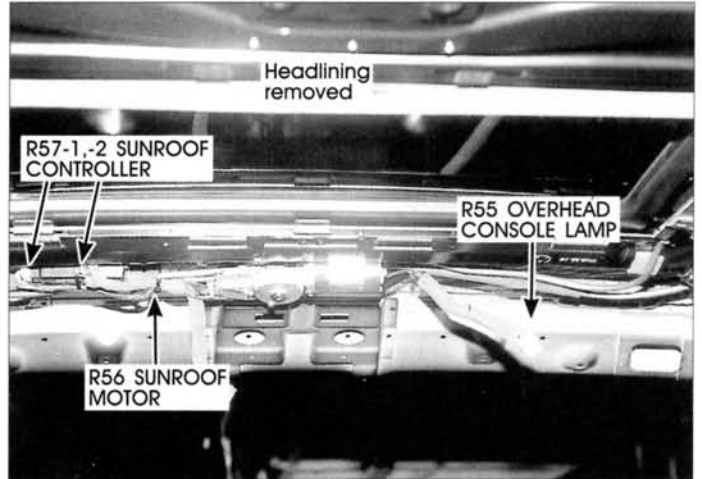

R55,R56,R57-1,R57-2

E3ME006R

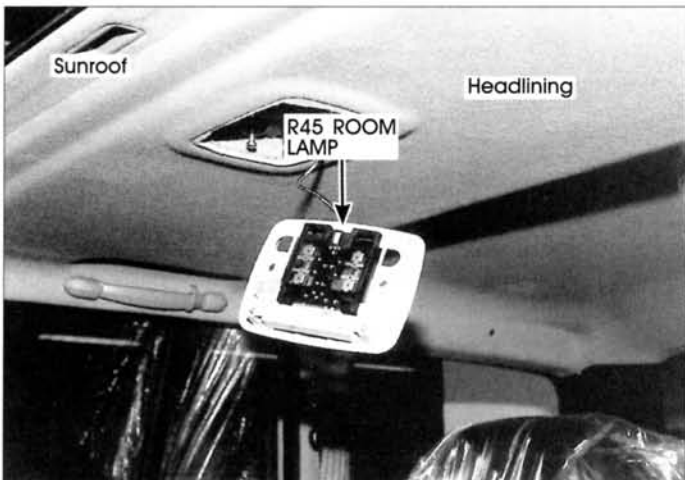

R45

E3ME006P

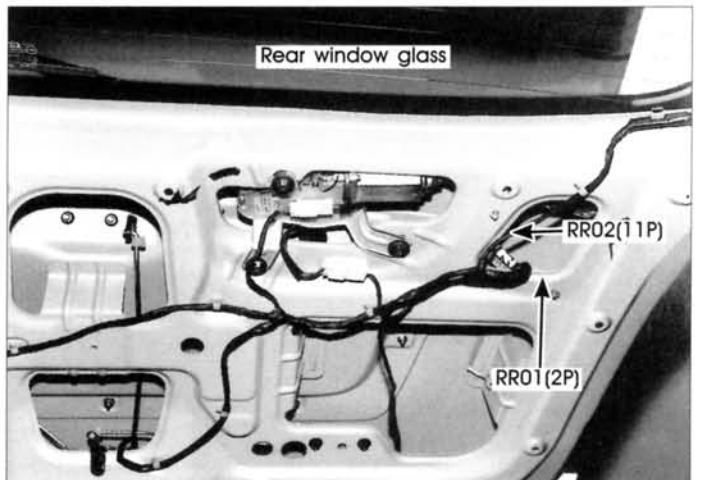

RR01,RR02

E3ME006S



R46

E3ME006Q

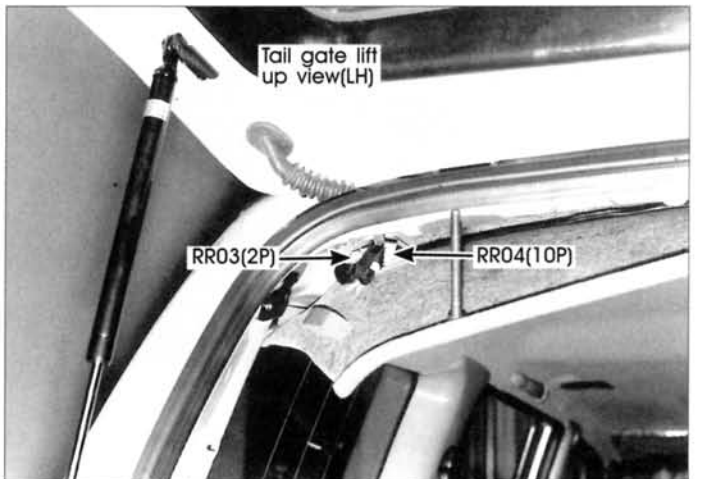

RR03,RR04

E3ME006T

A/C & AIR BAG HARNESS

A/C & AIR BAG HARNESS(1)

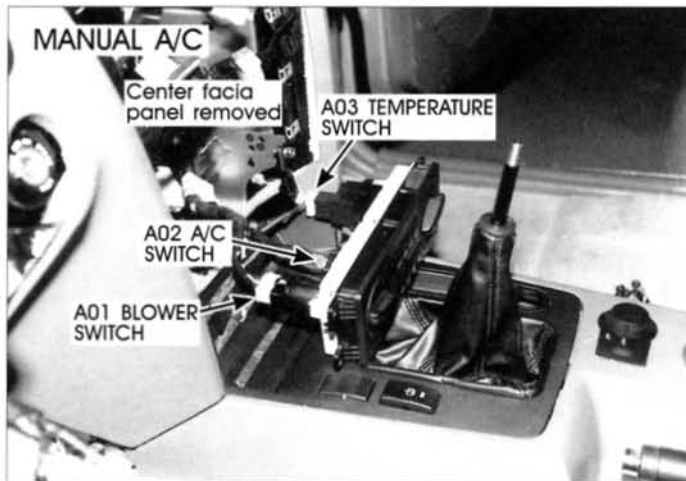

A01,A02,A03

E3ME007A

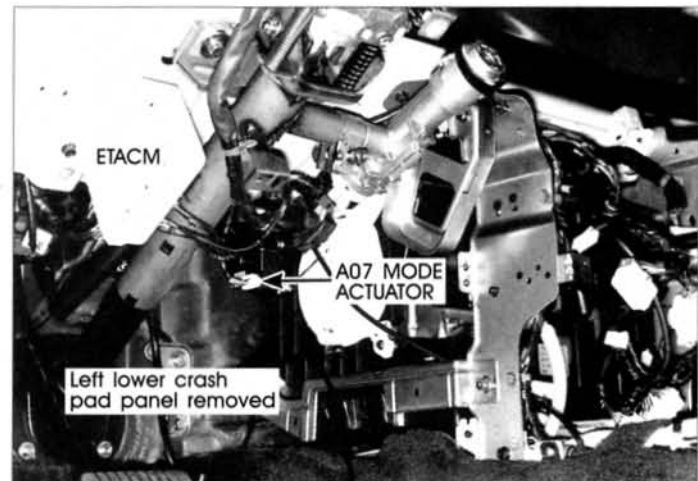

A07

E3ME007D

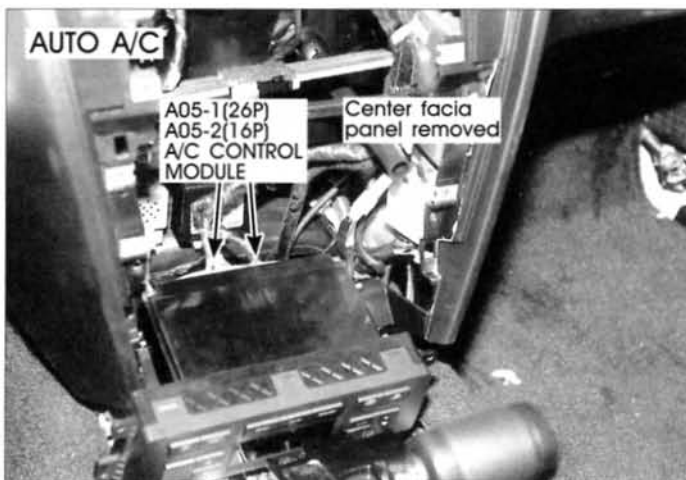

A05-1,A05-2

E3ME007B

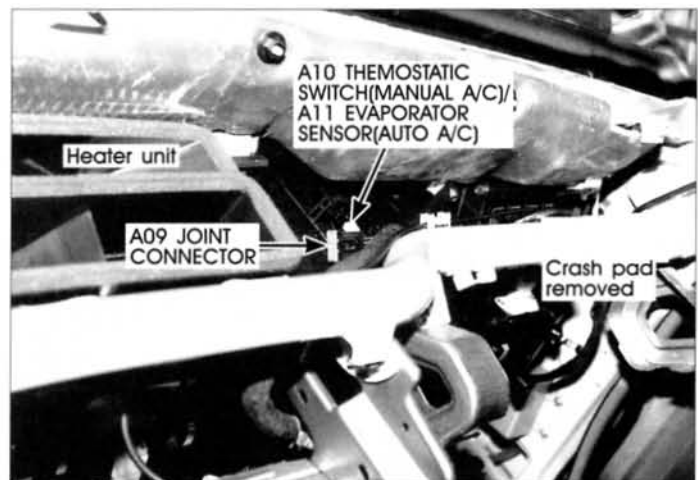

A09,A10,A11

E3ME007E

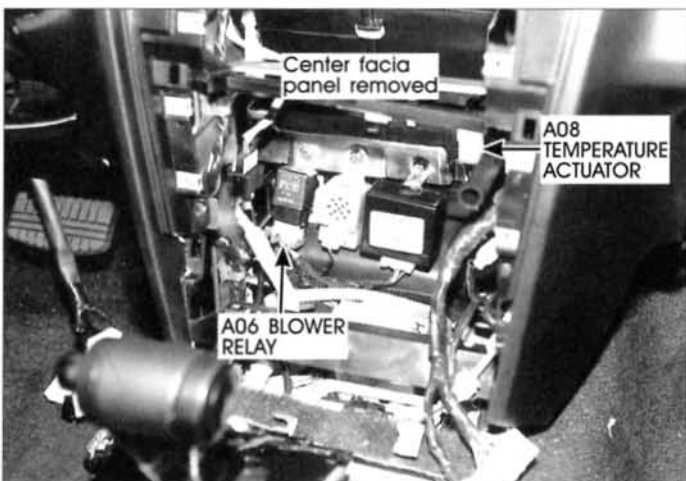

A06,A08

E3ME007C

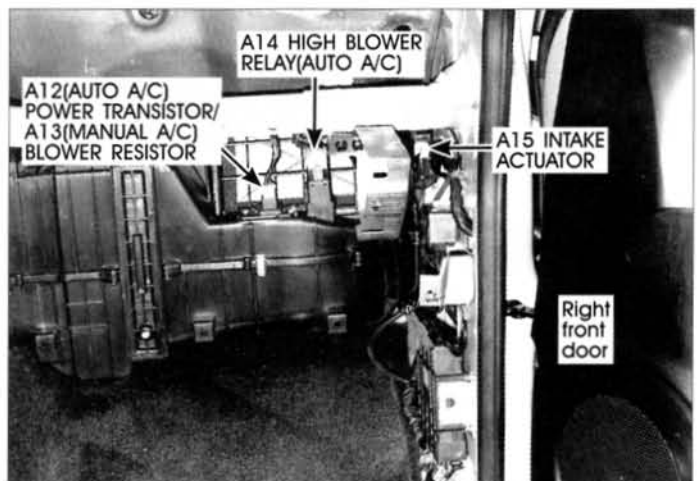

A12,A13,A14,A15

E3ME007F

A/C & AIR BAG HARNESS(2)

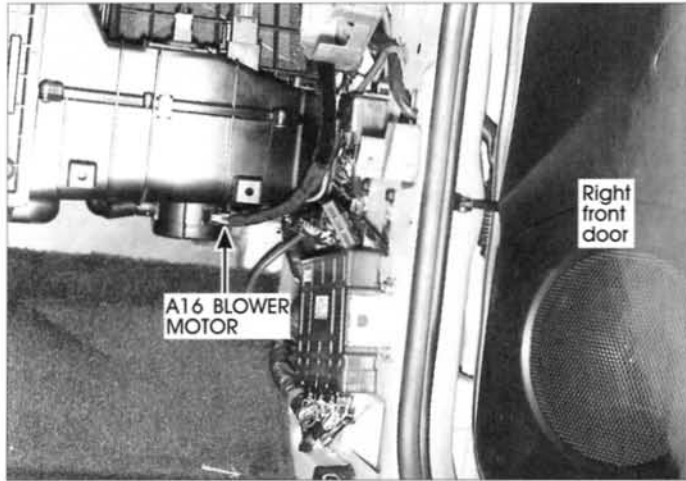

A16

E3ME007G

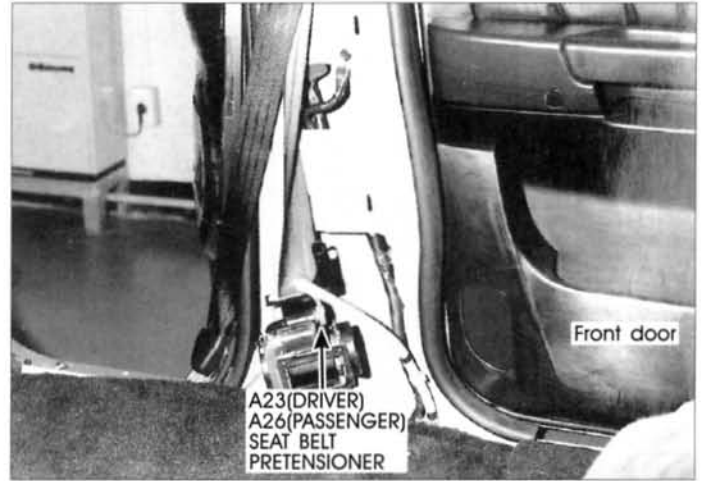

A23,A26

E3ME007K

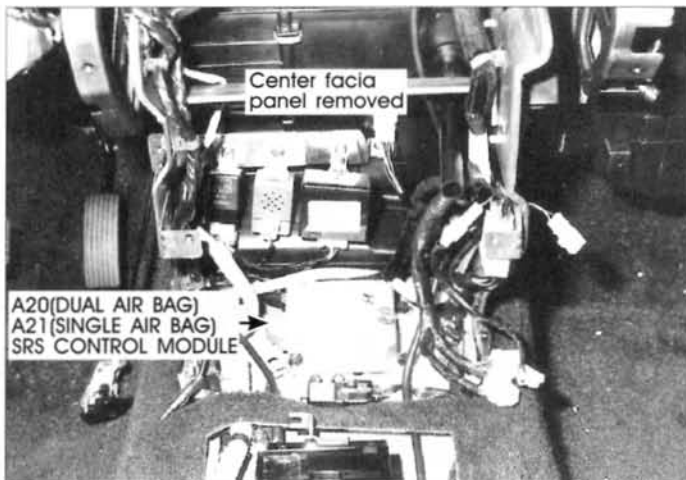

A20,A21

E3ME007H

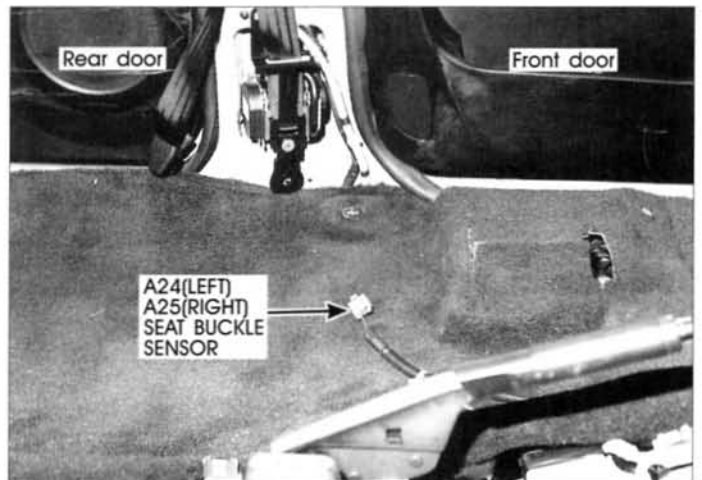

A24,A25

E3ME007L



A22

E3ME007J

GROUNDS

GROUNDS(1)

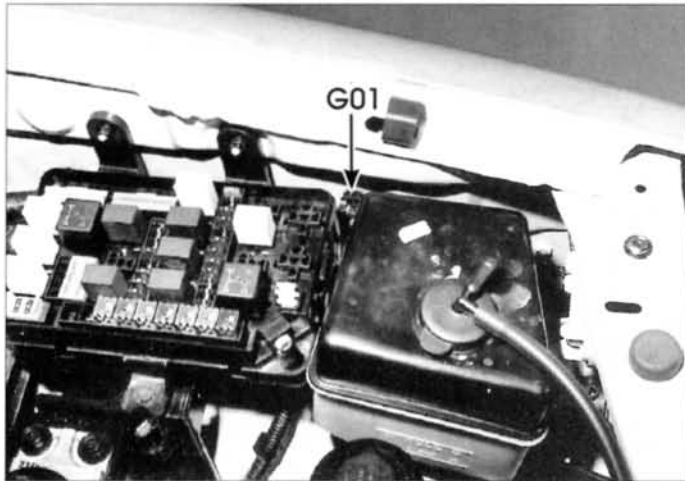

G01 E3ME008A

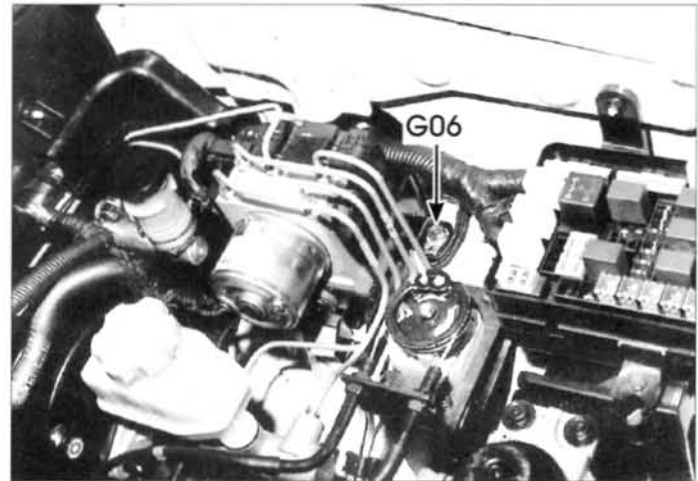

G06 E3ME008D

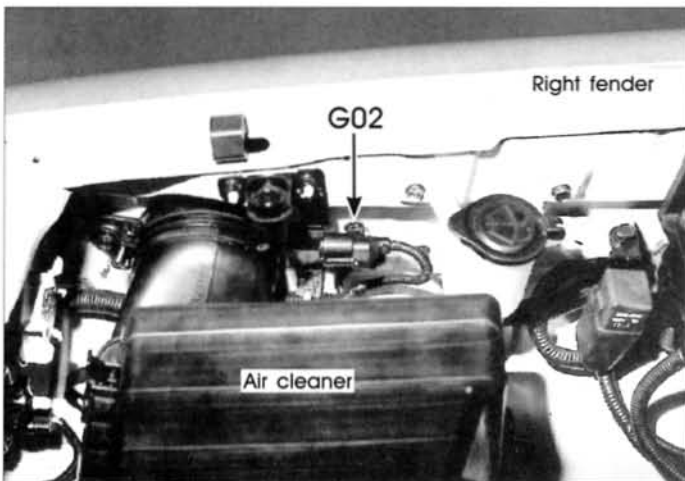

G02 E3ME008B

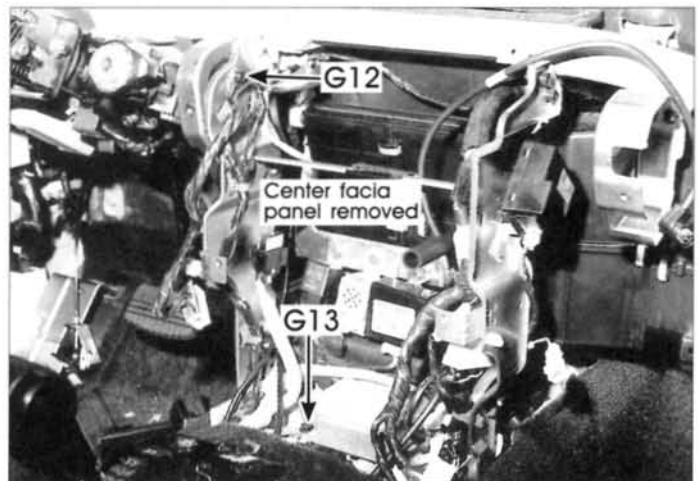

G12,G13 E3ME008E



G04,G07,G08,G09,G11 E3ME008C

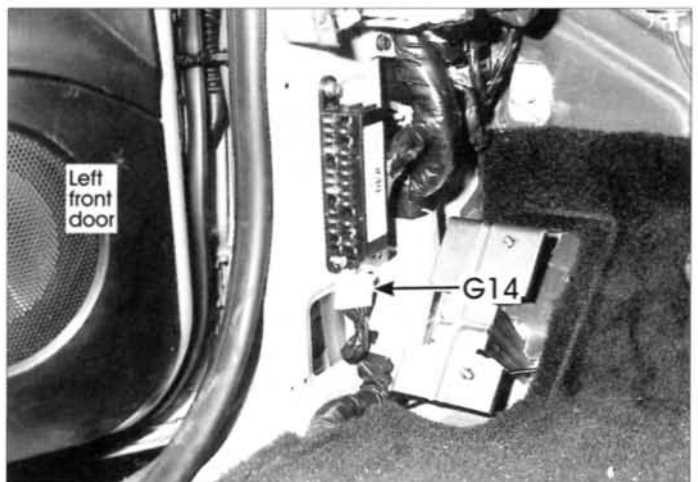

G14 E3ME008F

GROUNDS(2)

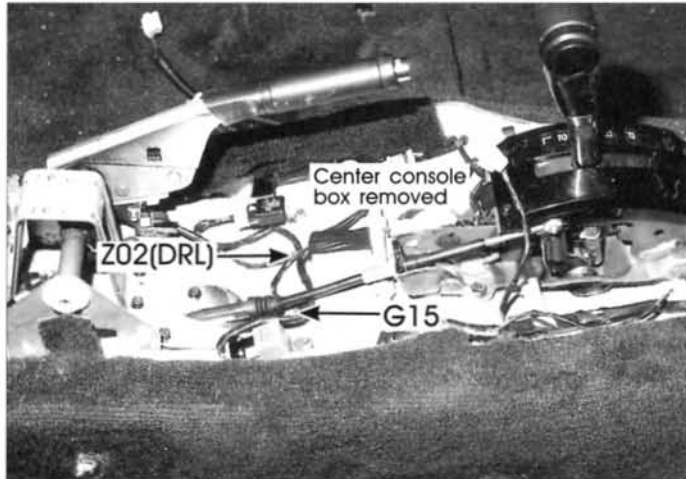

G15,Z02

E3ME008G

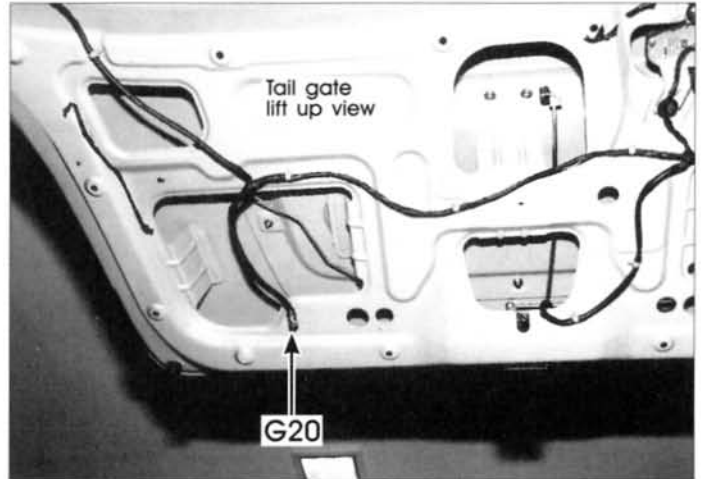

G20

E3ME008K

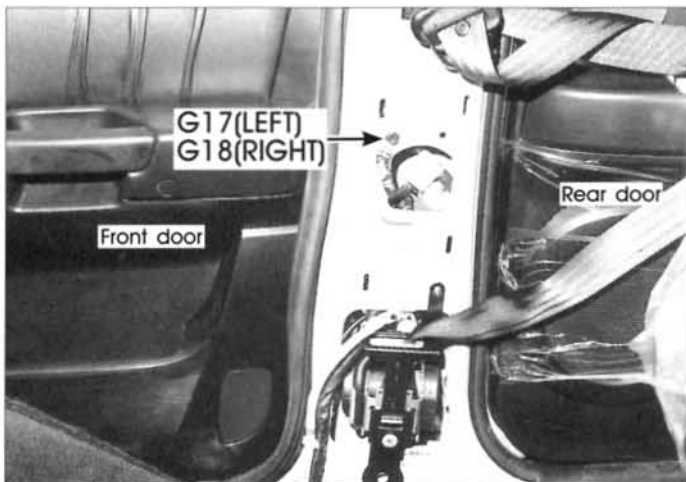

G17,G18

E3ME008H

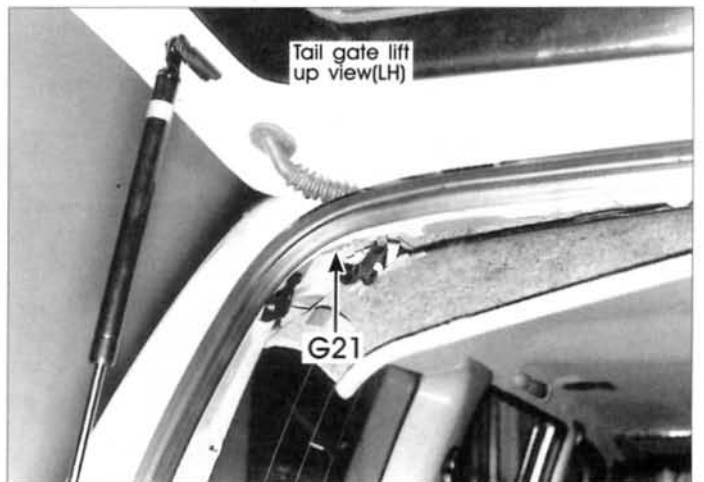

G21

E3ME008L

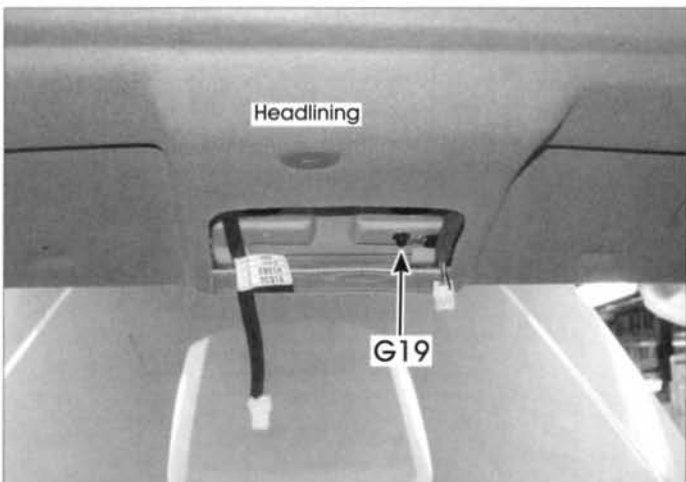

G19

E3ME008J

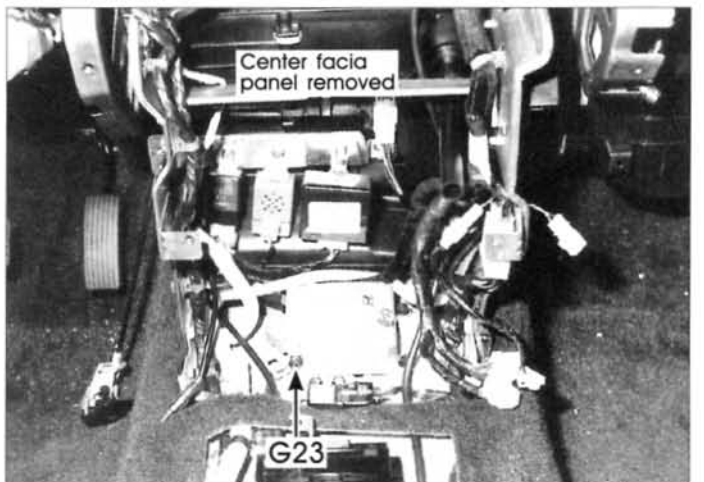

G23

E3ME008M

HOW TO USE THIS MANUAL

INTRODUCTION	GI -2
SYMBOLS	GI -6
TROUBLESHOOTING INSTRUCTIONS	GI-10



INTRODUCTION

EF4CEAFB

SCHEMATIC DIAGRAMS

This Manual consists of five major diagnostic sections for electrical problem troubleshooting.

The starting point of each system section is the schematic diagram. These diagrams show how all the components work together, such as electrical current paths from power source to ground(via electrical load), switch connections at each position, and other related circuit functions.

- Schematic diagrams
- Component location indexes
- Component locations
- Connector configurations
- Harness layouts

It is important to fully understand how a circuit works prior to troubleshooting and diagnosis.

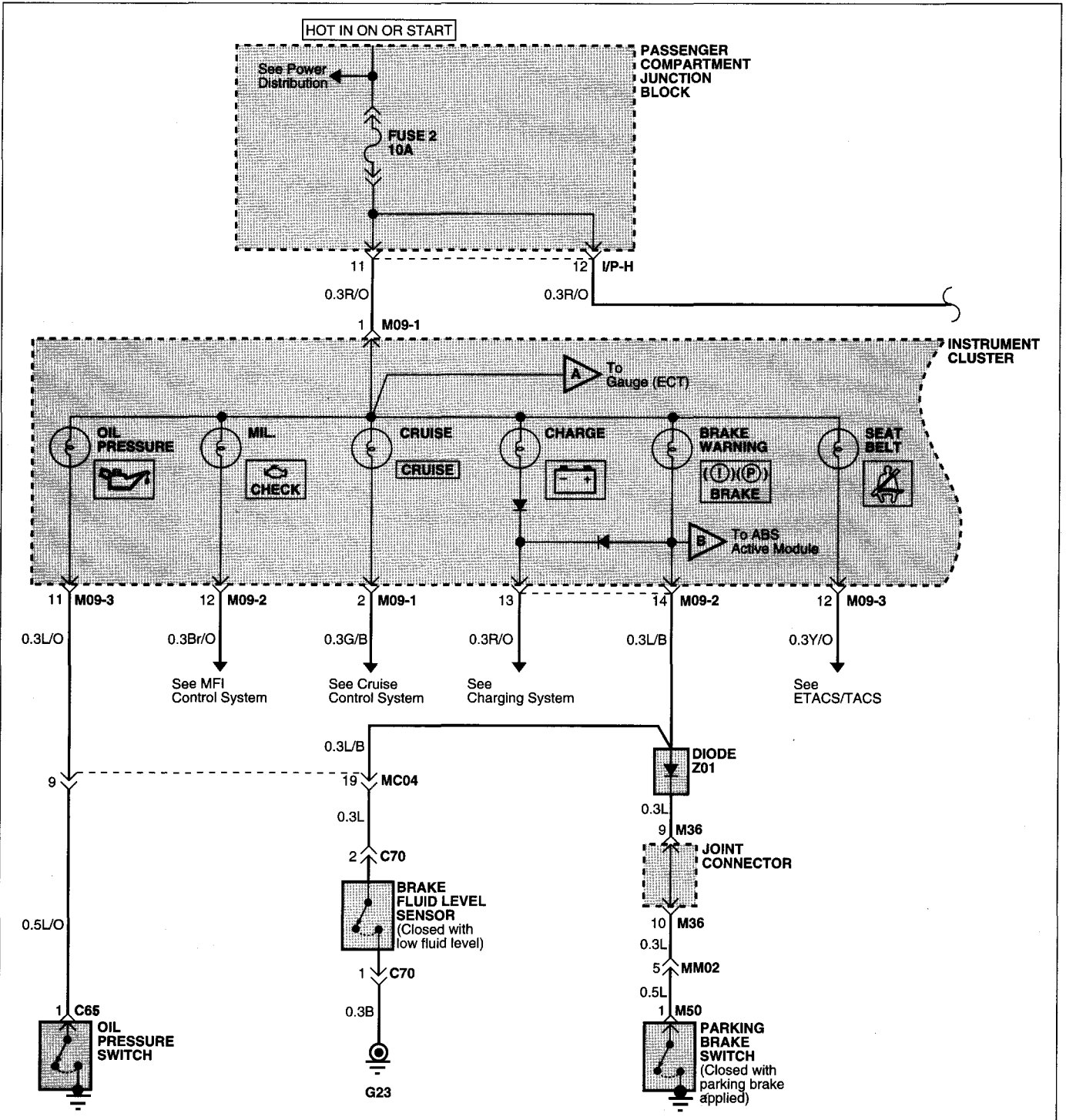

COMPONENT LOCATION INDEXES

When you want to locate the schematic components on the vehicle, use the Component Location Index which follows each schematic. A Component Location Index lists major components, connectors, grounds, diodes, and their physical location and page reference. Almost all components,

connectors or grounds, and diodes shown on a schematic can be pinpointed visually by using the Component Location Illustrations.

Components		Location Reference - Page
I12	Digital clock	CL-15
I16-1	Instrument cluster	CL-15
M55	Fuel sender	CL-19
M56	Fuel pump	CL-19
C34	Engine coolant temperature sender	CL-5, CL-8
Connectors		
MI01/MI02/MI03		CL-21
MC02		CL-21
CC02		CL-8
Grounds		
G01		CL-24
G02		CL-24

EG1001B

COMPONENT LOCATIONS

Component Locations make it easy to find the schematic components on the vehicle shown in the Component Location Index.

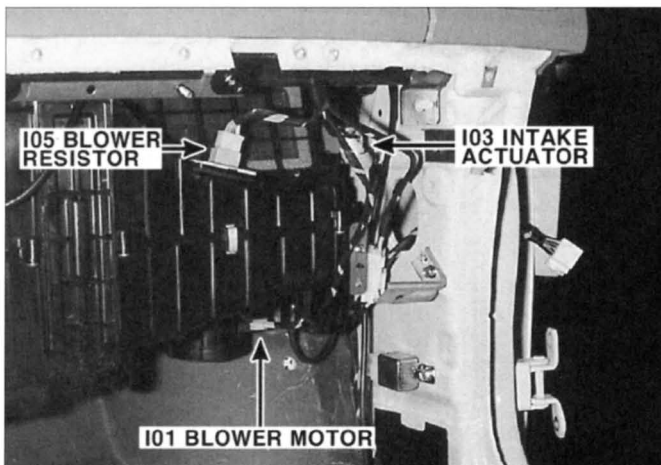

EG1001C

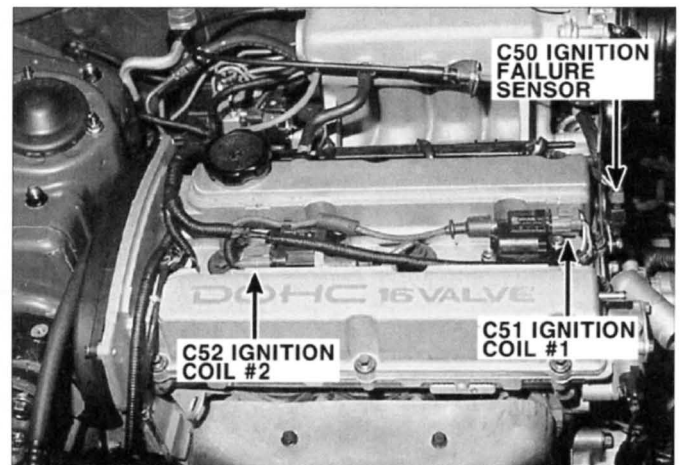



EG1001D

CONNECTOR CONFIGURATIONS

This section shows the cavity or terminal locations in all the multi-pin connectors shown in the schematic diagrams. It will help you to locate check points, together with the wire colors and terminal numbers in the schematic. The configuration drawings show the connector view as seen from a

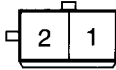
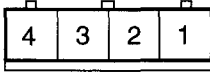
component after the harness connector has been disconnected. When more than one connector is connected to a component, the connectors are all shown together. Both halves of in-line connectors are shown together.

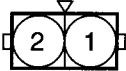
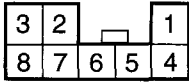
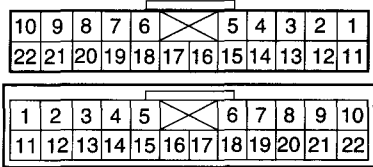
<p>E37-2</p> 	<p>E38</p> 	<p>E39</p> 	<p>E42</p> 
<p>E46</p> 	<p>E47</p> 	<p>EM01</p> 	

EGI001E

CONNECTOR VIEW AND NUMBERING ORDER

1. CONNECTOR VIEW

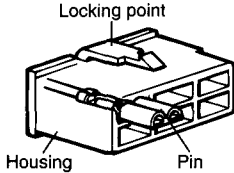
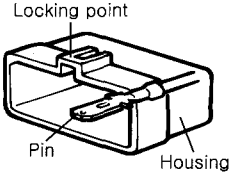
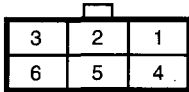
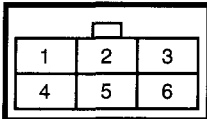
	Female	Male	Remarks
<p>Actual Illustration</p>			<p>It is not the shape of the connector housing, but the connector pin that distinguishes between male or female connectors. When numbering female and male connectors, refer to the numbering order in the following table. Some connectors may not follow this method of numbering order. For individual detailed numbering, refer to the CONNECTOR CONFIGURATIONS.</p>
<p>Illustration in the Shop manual</p>			

EGI001F

NOTE

UNLESS OTHERWISE STATED, ALL CONNECTOR VIEWS ARE FROM THE TERMINAL SIDE OF THE CONNECTOR.

2. NUMBERING ORDER

	Numbering order	Remarks
Female Connector		Numbered in order from upper right to lower left
Male Connector		Numbered in order from upper left to lower right

EGI001G

HARNESS LAYOUTS

Harness layouts show the routing of the major wiring harnesses, the in-line connectors and the splices between the major harnesses. These layouts will make electrical troubleshooting easier.

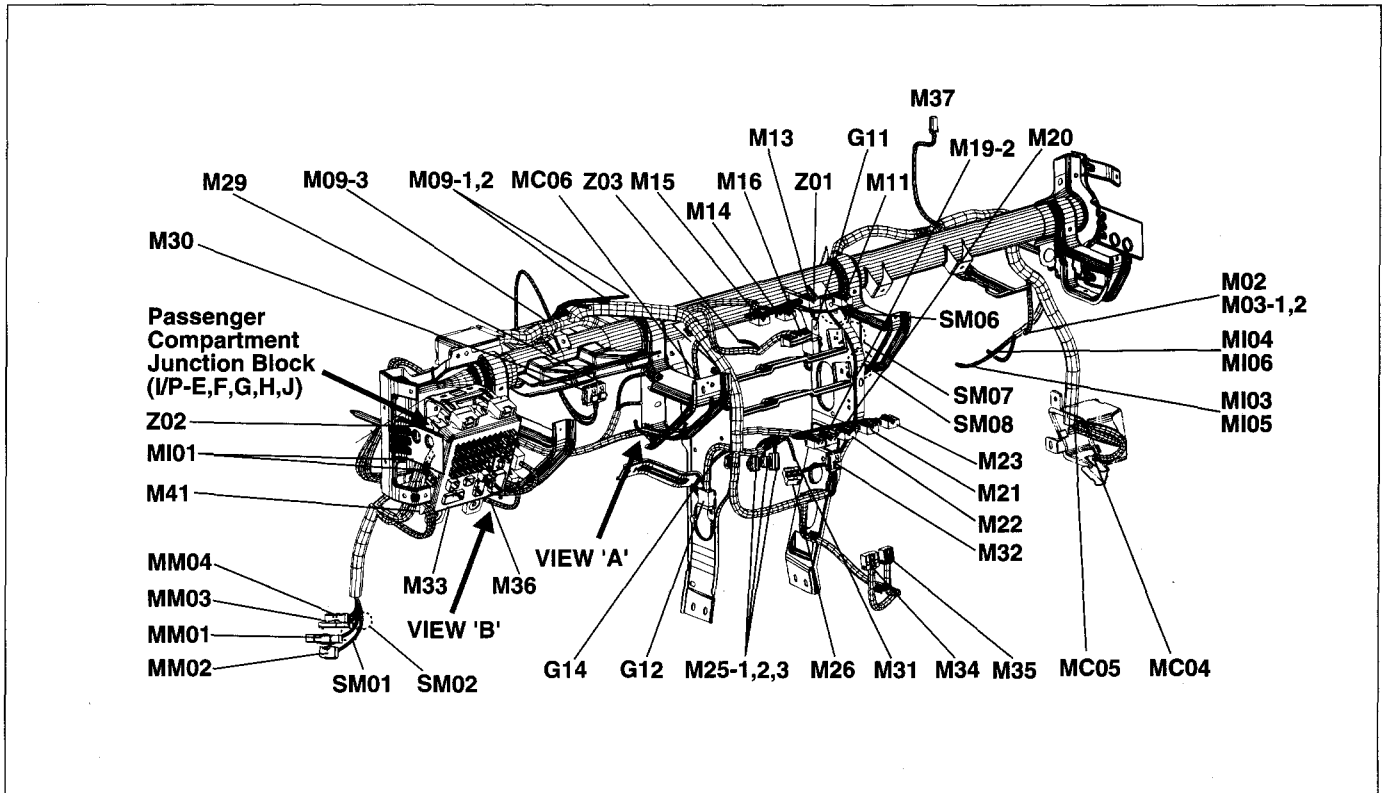

EGI001H

SYMBOLS EC552FFE

The symbols and abbreviations explained in this section are used throughout the manual.

SYMBOLS IN SCHEMATIC

Components

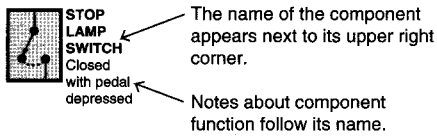
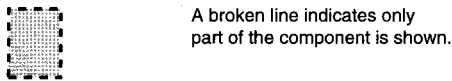
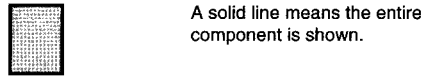

Connectors

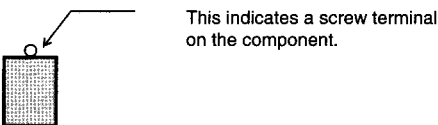
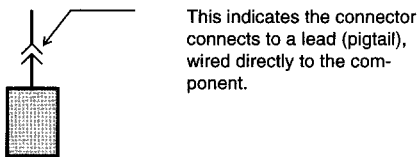
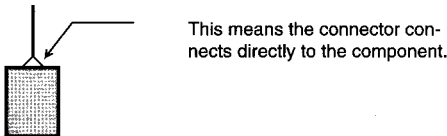
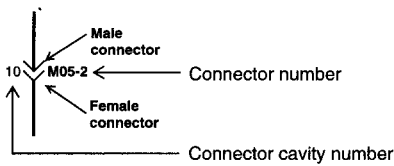

Diode

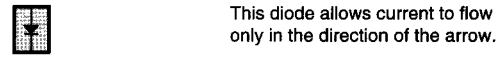

Fuse and Fusible link

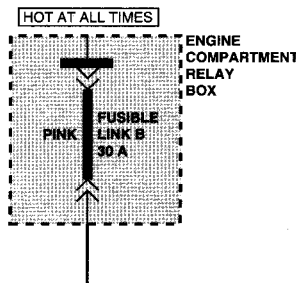
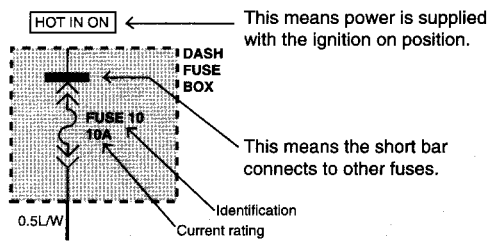

Circuit Breaker

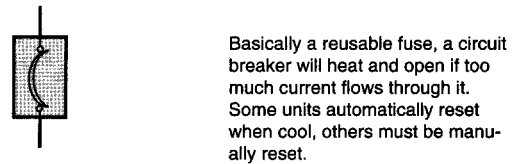

Wires

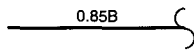

A wavy line means the wire is broken but is to be continued.

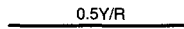

Wire insulation is yellow with a red strip.

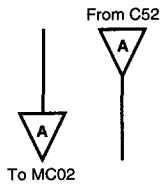

Current path is continued on the same page or another page. The arrow shows the direction of current flow. You should look for the "A" in the marked position.

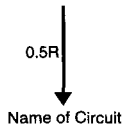

A wire connects to another circuit. The wire is shown again on that circuit which the arrow is pointing.

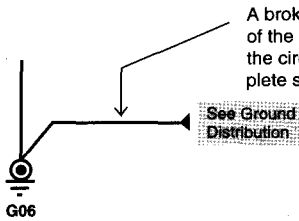

A broken line means only some of the circuit is shown; refer to the circuit listed for the complete schematic.

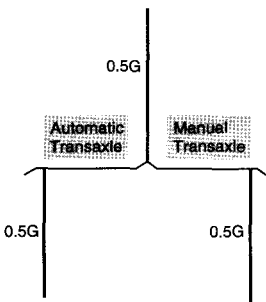

Wire choices for options or different models are labeled and shown with a "choice" bracket like this.



This dashed line means the R(red) and Y/L(yellow/blue) wires are both in connector MC01.

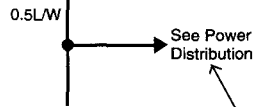
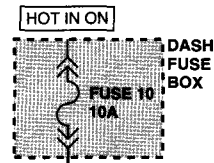

Where separate wires join, only the splice is shown; for details on the additional wiring, refer to the circuit listed.

Splices

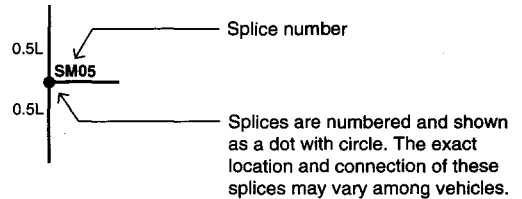

Ground - "G"

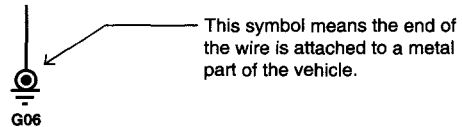

Shield Wire

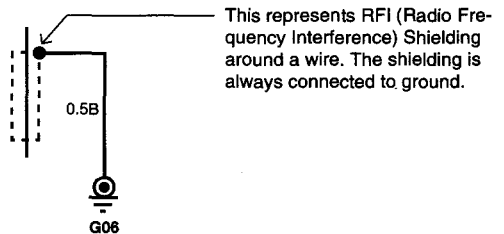

Switches

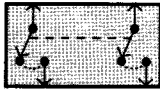

These switches move together: a dashed line shows a mechanical connection between them.

Joint Connectors

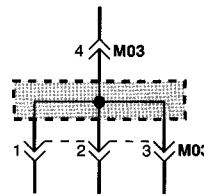

This is a connector showing the joining wires.

Relays

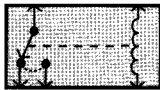

This is a relay shown with no current flowing through its coil. When a current flows through coil, contact will toggle.

Normally open contact
Normally closed contact

Indicator

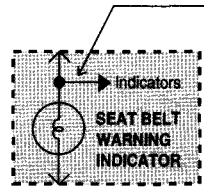

This indicates seat belt warning indicator continues to other indicators within instrument cluster.

This is an indicator which displays the lighted symbol.

EGI002C

WIRE COLOR ABBREVIATIONS

The following abbreviations are used to identify wire colors in the circuit schematics.

Symbol	Color of wire	Symbol	Color of wire
B	Black	O	Orange
Br	Brown	P	Pink
G	Green	R	Red
Gr	Gray	T	Tan
L	Blue	W	White
Lg	Light green	Y	Yellow
LI	Light blue		

HARNESS CLASSIFICATION

Electrical wiring connectors are classified according to the wiring parts in the Harness Layouts.

Harness name	Location	Symbol
Engine harness	Engine compartment	E
Main, Floor, Roof, Sunroof, Seat warmer ext. harness	Passenger compartment, Floor, Roof	M
Control, Injector harness	Engine compartment	C
Tail gate, Tail gate ext. harness	Tail gate	R
Air bag harness, A/C harness	Under crash pad and Floor	A
Door harness	Door	D

CONNECTOR IDENTIFICATION

A connector identification symbol consists of a wiring harness location classification symbol corresponding to a wiring harness location and number corresponding to the

connector. These connector locations can be found in the **HARNESSES LAYOUTS**.

For example :

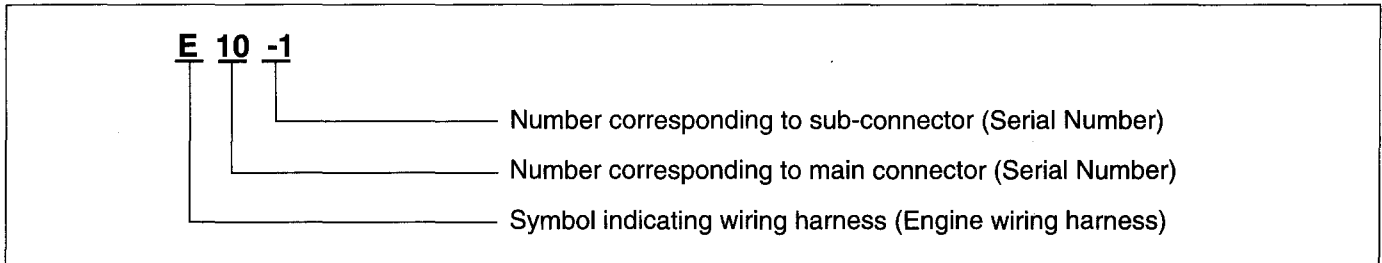

EG1002D

NOTE

Connectors which connect each wiring harness are represented by the following symbols.

For example :

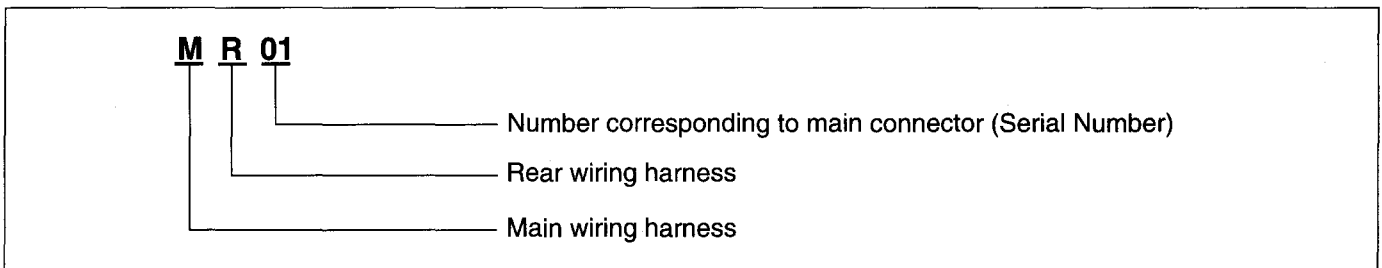

EG1002E

JUNCTION BLOCK IDENTIFICATION

A junction block identification symbol consists of a wiring harness location classification symbol corresponding to a wiring harness location and number corresponding to the connector in the junction block.

For example :

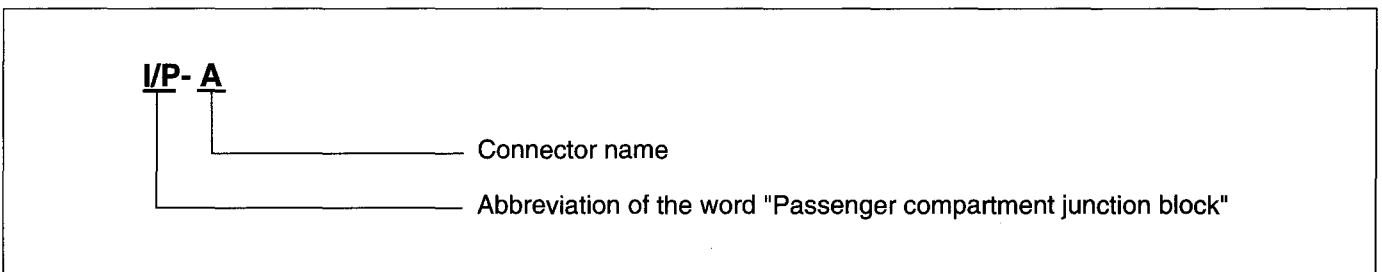

EG1002F

For example :

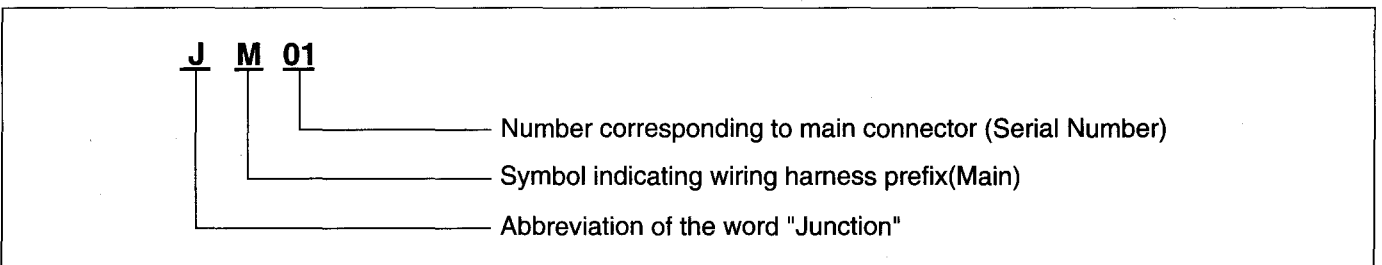

EG1002G

TROUBLESHOOTING INSTRUCTIONS

EF429DF8

TROUBLESHOOTING PROCEDURES

The following five-steps troubleshooting procedure is recommended.

1. Verify the customer's complaints

Turn on all the components in the problem circuit to check the accuracy of the customer's complaints. Note the symptoms. Do not begin disassembly or testing until you have narrowed down the probable causes.

2. Read and analyze the schematic diagram

Locate the schematic for the problem circuit. Determine how the circuit is supposed to work by tracing the current paths from the power source through the system components to ground. If you do not understand how the circuit should work, read the circuit operation text. Also check other circuits that share with the problem circuit. The name of circuits that share the same fuse, ground, or switch, for example, are referred to on each diagram. Try to operate any shared circuits you did not check in step 1. If the shared circuit works, the shared wiring is okay, and the cause must be within the wiring used only by the problem circuit. If several circuits fail at the same time, the fuse or ground is a likely cause.

3. Inspect the circuit/ component with the problem isolated

Make a circuit test to check the diagnosis you made in step 2. Remember that a logical, simple procedure is the key to efficient troubleshooting. Narrow down the probable causes using the troubleshooting hints and system diagnosis charts. Test for the most likely cause of failure first. Try to make tests at points that are easily accessible.

4. Repair the problem

Once the problem is found, make the necessary repairs.

5. Make sure the circuit works

Repeat the system check to be sure you have repaired the problem. If the problem was a blown fuse, be sure to test all of the circuits on that fuse.

TROUBLESHOOTING EQUIPMENT

VOLTMETER AND TEST LAMP

Use a test lamp or a voltmeter on circuits without solid-state units and use a test lamp to check for voltage. A test lamp is made up of a 12-volt light bulb with a pair of leads attached. After grounding one lead, touch the other lead to various points along the circuit where voltage should be present. When the bulb goes on, there is voltage at the point being tested.>

CAUTION

A number of circuits include solid-state modules, such as the Engine Control Module (ECM), used with computer command control injection. Voltage in these circuits should be tested only with a 10-megaohm or higher impedance digital voltmeter. Never use a test lamp on circuits that contain solid state modules. Damage to the modules may result.

A voltmeter can be used in place of a test lamp. While a test lamp shows whether the voltage is present or not, a voltmeter indicates how much voltage is present.

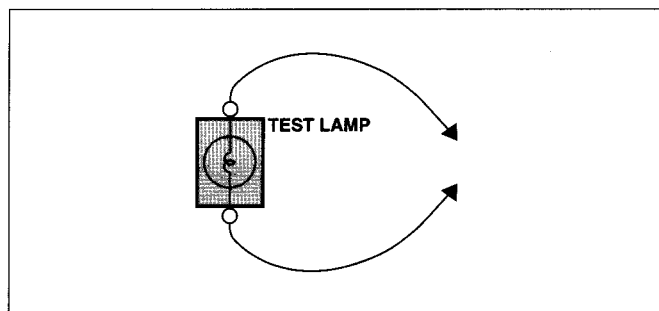

EGI003A

SELF-POWERED TEST LAMP AND OHMMETER

Use a self-powered test lamp or an ohmmeter to check for continuity. The ohmmeter shows how much resistance there is between two points along a circuit. Low resistance means good continuity.

CAUTION

Never use a self-powered test lamp on circuits that contain solid state modules. Damage to these modules may result.

An ohmmeter can be used in place of a self-powered test lamp. The ohmmeter shows how much resistance there is between two points along a circuit. Low resistance means good continuity.

Circuits which include any solid-state devices should be tested only with a 10-megaohm or higher impedance digital multimeter. When measuring resistance with a digital multimeter, the battery negative terminal should be disconnected. Otherwise, there may incorrect readings. Diodes and solid-state devices in a be circuit can make an ohmmeter give a false reading. To find out if a component is affecting a measurement, take one reading, reverse the leads and take a second reading. If different the solid-state device is affecting the measurement.

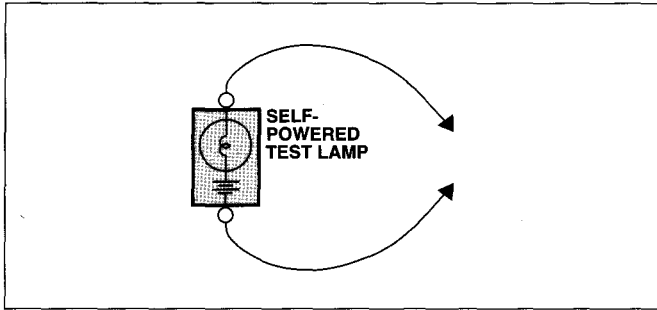

EGI003B

JUMPER WIRE WITH FUSE

Use a jumper wire with a fuse to by-pass an open circuit.

A jumper wire is made up of an in-line fuse holder connected to a set of test leads. This tool is available with small clamp connectors providing adaption to most connectors without damage.

CAUTION

Do not use a fuse with a higher rating than the specified fuse that protects the circuit being tested. Do not use this tool in any situation to substitute an input or output at the solid-state control module, such as ECM, TCM, etc.

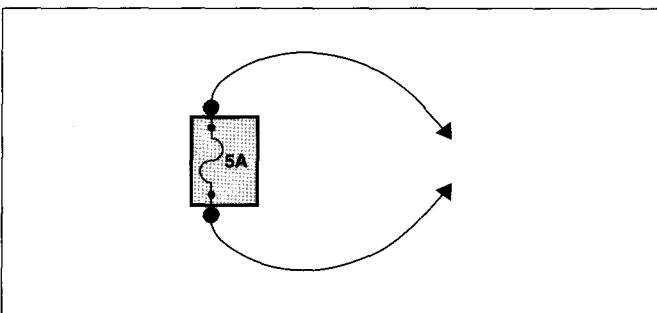

EGI003C

SHORT FINDER

A short finder is available to locate a short to ground. The short finder creates a pulsing magnetic field in the shorted circuit and shows you the location of the short through body trim or sheet metal.

TROUBLESHOOTING TEST

1. TESTING FOR VOLTAGE

This test measures voltage in a circuit. When testing for voltage at a connector, you do not have to separate the two halves of the connector. Instead, probe the connector from the back(backprobe). Always check both sides of the connector because dirt and corrosion between its contact surfaces can cause electrical problems.

- A. Connect one lead of a test lamp or voltmeter to a ground. If you are using a voltmeter, be sure it is the voltmeter's negative test lead you have connected to ground.
- B. Connect the other lead of the test lamp or voltmeter to a selected test point(connector or terminal).
- C. If the test lamp glows, there is voltage present. If you are using a voltmeter, note the voltage reading. A loss of more than 1 volt from specification indicates a problem.

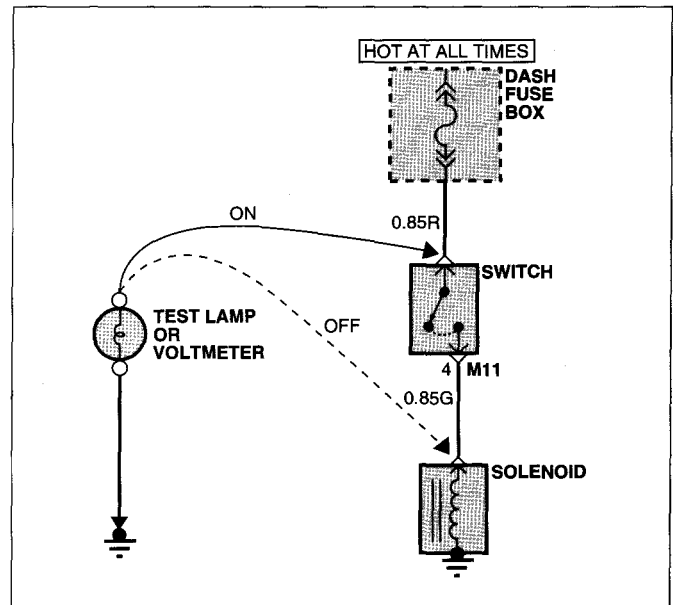

EGI003D

2. TESTING FOR CONTINUITY

- A. Disconnect the battery negative terminal.
- B. Connect one lead of a self-powered test lamp or ohmmeter to one end of the part of the circuit you wish to test. If you are using an ohmmeter, hold the leads together and adjust the ohmmeter to read zero ohms.
- C. Connect the other lead to the other end.
- D. If the self-power test lamp glows, there is continuity. If you are using an ohmmeter, low or zero resistance means good continuity.

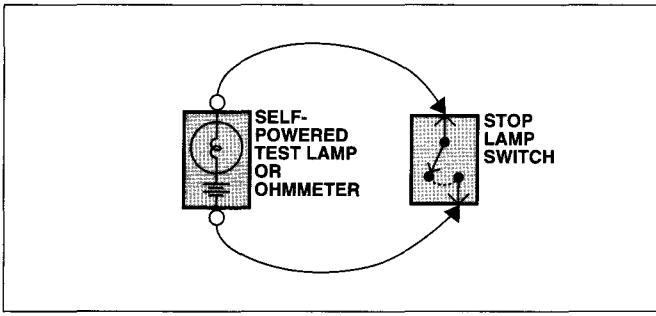

EGI003E

3. TESTING FOR SHORT TO GROUND

- A. Disconnect the battery negative terminal.
- B. Connect one lead of a self-powered test lamp or an ohmmeter to the fuse terminal on the load side.
- C. Connect the other lead to a ground.
- D. Beginning near the fuse block move the harness from side to side. Continue this procedure (about six inches apart) while watching the self-powered test lamp or ohmmeter.
- E. When the self-powered test lamp glows, or ohmmeter registers, there is a short to a ground in the wiring near that point.

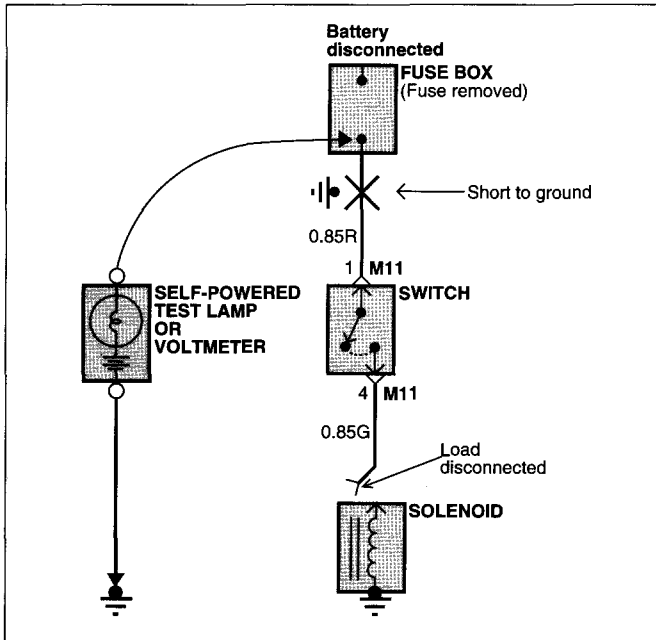

EGI003F

4. TESTING FOR A SHORT WITH A SHORT FINDER

- A. Remove the blown fuse. Leave the battery connected.
- B. Connect the short finder across the fuse terminals.
- C. Close all switches in series in the circuit that is being testing.
- D. Turn on the short circuit locator. It sends pulses of current to the short. This creates a pulsing magnetic field around the wiring between the fuse box and the short.
- E. Beginning at the fuse box, slowly move the short finder along the circuit wiring. The meter will show current pulses through sheet metal and body trim. As long as the meter is between the fuse and the short, the needle will move with each current pulse. Once the meter is moved past the point of the short, the needle will stop moving. Check around this area to locate the cause of the short circuit.

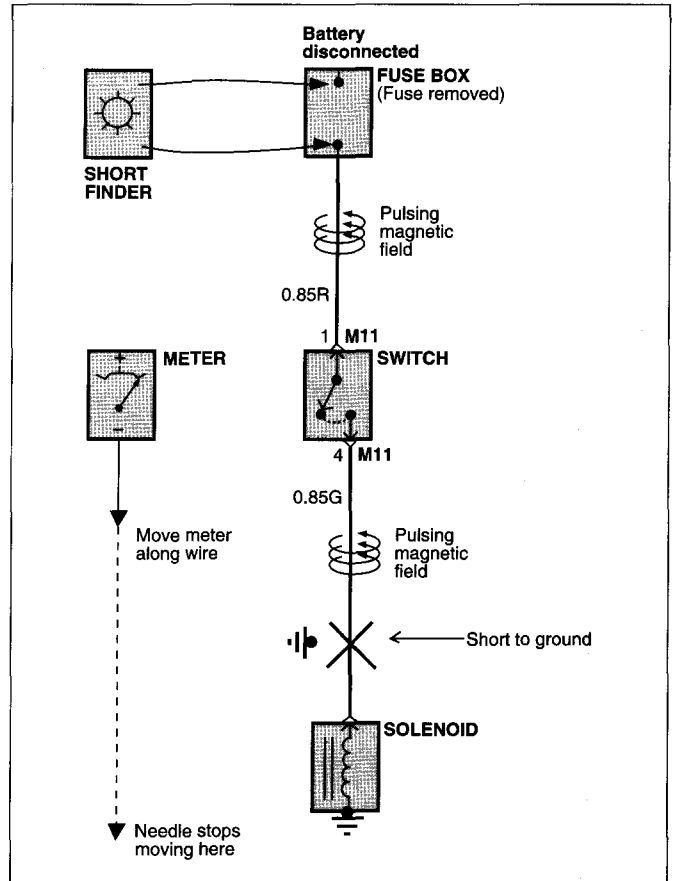

EGI003G