

Engine & Cooling	Fuel	Ignition	Electrical	Running gear	Torque settings	Capacities	Notes & Illustrations
------------------	------	----------	------------	--------------	-----------------	------------	-----------------------



Automotive Technical DATA BOOK

Click on one of the buttons above to view data for this car. To return to this screen and make another choice, click anywhere on the data screen.

MENU **HELP**

Engine and cooling system 125P, 1300 1985 to 1992

Type		BA OHV
Capacity (cm ³) / number of cylinders		1295 / 4
Compression ratio / pressure	bar	9.0 / ≥10.3
Oil pressure	bar	[3.5 to 4.9]
Oil temperature	°C	100
Valve clearance - inlet	mm	0.20
Valve clearance - exhaust	mm	0.25
Firing order		1-3-4-2
No 1 cylinder position		F
Thermostat opening temperature	°C	80 to 84
Radiator cap pressure	bar	0.8±0.1

Fuel system 125P, 1300 1985 to 1992

Idle speed - manual [auto]	rpm	800 to 850
Fast idle speed - manual [auto]	rpm	—
CO @ idle speed [3000 rpm] - see page VI	%	1.0 to 2.0
HC @ idle speed [3000 rpm] - see page VI	ppm	≤1200
CO ₂ @ idle speed [3000 rpm] - see page VI	%	—
O ₂ @ idle speed [3000 rpm] - see page VI	%	—
Carburettor / fuel injection		Weber/FOS
Type / ref		W: 34 DCHD. FOS: 34S2C4 / C14
Main jet / needle		W: 115, 135. FOS: 115, 125
Injection pressure	bar	—
Pump pressure	bar	0.20 to 0.30
Octane rating	RON	95[L] ¹

Ignition system 125P, 1300 1985 to 1992

Type		Electronic
Ignition coil		Zelmot
Primary resistance	ohms	0.75 to 0.81
Ballast resistor	ohms	—
Voltage - Tmnl 15(+) to earth	V	—
Distributor		Zelmot
Points gap (air gap)	mm	[0.30 to 0.40]
Dwell angle	° (%)	—
Condenser capacity	µF	—
Rotation		Clockwise
Ignition timing - basic [static	° Crankshaft @ rpm	5 BTDC @ 800
V = Vacuum NV = No Vacuum		NV
Total ignition advance	° Crankshaft @ rpm	—
Centrifugal check.	° Crankshaft @ rpm	0 @ 800
	° Crankshaft @ rpm	23 @ 3000
	° Crankshaft @ rpm	29±2 @ 4000
Vacuum range check	mbar	51 to 406
Maximum vacuum advance	° Crankshaft	10±2
Spark plugs		Nippon Denso/Champion
Type		W20EXU / N9YC
Electrode gap	mm	0.90 to 1.00

Electrical system 125P, 1300 1985 to 1992

Battery	V / CC / RC	12 / 45Ah
Alternator voltage / full load current / engine rpm		13.9 to 14.5 / 44 / 3000
Starter motor current / voltage - cranking	A / V	—
- locked	A / V	575 / 6.3

Running gear 125P, 1300 1985 to 1992

Brakes -		
Front (min. friction material thickness)	mm	1.5
Rear (min. friction material thickness)	mm	1.5
Tyres		
Saloon	Size	165x13
Estate / Van	Size	—
Pressure - front / rear - Saloon	bar	1.7 / 1.9
- Estate / Van	bar	—
Front suspension / wheel alignment		
Toe-in (+) / Toe-out (-)	mm [°]	+3.0±1.0
Camber		+30'±30'
Castor		+4°30'±30'
King pin inclination		+6°±20'
Rear suspension / wheel alignment		
Toe-in (+) / Toe-out (-)	mm [°]	—
Camber		—

Torque wrench settings 125P, 1300 1985 to 1992

Cylinder head - stage 1	Nm	98
- stage 2	Nm	—
Cylinder head - stage 3	Nm	—
- stage 4	Nm	—
Big-end bearings	Nm	70
Main bearings	Nm	103
Clutch cover	Nm	30
Flywheel [driveplate]	Nm	79
Front hubs	Nm	WSM
Rear hubs	Nm	—
Wheel nuts / bolts	Nm	86
Spark plugs	Nm	25 to 30

Capacities 125P, 1300 1985 to 1992

Engine oil & filter	litres	4.0
Gearbox - 4-speed [5-speed]	litres	1.4 [1.6]
Automatic transmission - refill	litres	—
Final drive	litres	1.2
Cooling system	litres	7.5
Fuel tank	litres	45

Notes and Illustrations

¹1989 ▶: [E 95 RON]

1: Idle speed 2: CO / Mixture

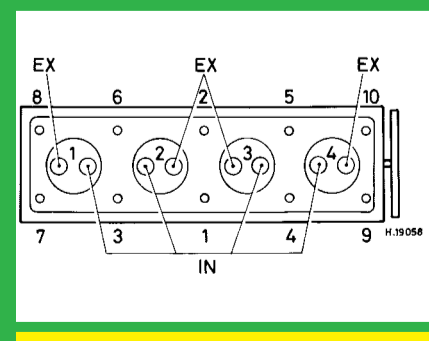

1295 cm³

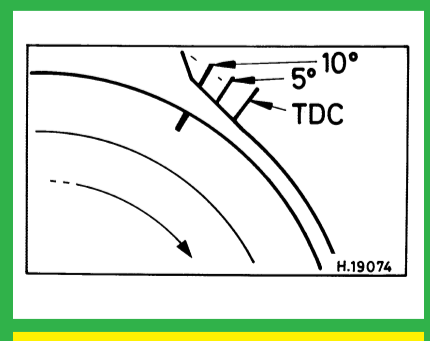

1295 cm³

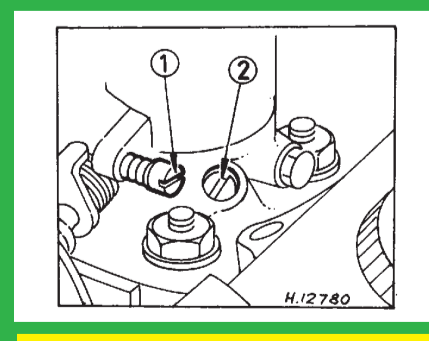

Weber / FOS