

Engine & Cooling	Fuel	Ignition	Electrical	Running gear	Torque settings	Capacities	Notes & Illustrations
------------------	------	----------	------------	--------------	-----------------	------------	-----------------------



Automotive Technical DATA BOOK

Click on one of the buttons above to view data for this car. To return to this screen and make another choice, click anywhere on the data screen.

MENU

HELP

Engine and cooling system 760, 2.8i 1988 to 1990

Type		B280E. 125kW
Capacity (cm ³) / number of cylinders		2849 / 6
Compression ratio / pressure	bar	10.0 / ≥7.9
Oil pressure	bar	0.98 [3.9]
Oil temperature	°C	H
Valve clearance - inlet	mm	0.10 to 0.15
- exhaust	mm	0.25 to 0.30
Firing order		1-6-3-5-2-4
No 1 cylinder position		RL
Thermostat opening temperature	°C	86 to 88
Radiator cap pressure	bar	1.5

Fuel system 760, 2.8i 1988 to 1990

Idle speed - manual [auto]	rpm	750
Fast idle speed - manual [auto]	rpm	—
CO @ idle speed [3000 rpm] - see page VI	%	1.0-0.5+1.0
HC @ idle speed [3000 rpm] - see page VI	ppm	≤1200
CO ₂ @ idle speed [3000 rpm] - see page VI	%	—
O ₂ @ idle speed [3000 rpm] - see page VI	%	—
Carburettor / fuel injection		Bosch
Type / ref		LH-Jetronic 2.2
Main jet / needle		—
Injection pressure	bar	2.5
Pump pressure	bar	1.9 to 3.0
Octane rating	RON	95[E 95 RON]

Ignition system 760, 2.8i 1988 to 1990

Type		EZ 115K
Ignition coil		Bosch
Primary resistance	ohms	0.6 to 0.8
Ballast resistor	ohms	—
Voltage - Tmnl 15(+) to earth	V	—
Distributor		Bosch
Points gap (air gap)	mm	[0.30]
Dwell angle	° (%)	—
Condenser capacity	µF	—
Rotation		Clockwise
Ignition timing - basic [static	° Crankshaft @ rpm	10 BTDC @ 730 to 770
V = Vacuum NV = No Vacuum		—
Total ignition advance	° Crankshaft @ rpm	Not adjustable, EZK system
	° Crankshaft @ rpm	—
	° Crankshaft @ rpm	—
Centrifugal check.	° Crankshaft @ rpm	Computer control
	° Crankshaft @ rpm	—
	° Crankshaft @ rpm	—
Vacuum range check	mbar	Computer control
Maximum vacuum advance	° Crankshaft	—
Spark plugs		Bosch/Champion
Type		HR5DC / RS7YC
Electrode gap	mm	0.60 to 0.70

Electrical system 760, 2.8i 1988 to 1990

Battery	V / CC / RC	12 / 500 / 110
Alternator voltage / full load current / engine rpm		13.8 to 14.6 / _ / 3000
Starter motor current / voltage - cranking	A / V	1.1kW: 70 / 11.5 ¹
- locked	A / V	1.1kW: 480 to 560 / 7.4 ²

Running gear 760, 2.8i 1988 to 1990

Brakes -		
Front (min. friction material thickness)	mm	3.0
Rear (min. friction material thickness)	mm	2.0

Tyres		
Saloon	Size	195/60x15
Estate / Van	Size	195/60x15: 185/65x15
Pressure - front / rear - Saloon	bar	2.0 / 1.9
- Estate / Van	bar	1.9 / 2.1

Front suspension / wheel alignment

Toe-in (+) / Toe-out (-)	mm [°]	+4.0±0.8
Camber		-0.2° to +0.8°
Castor		+4.5° to 5.5°
King pin inclination		—

Rear suspension / wheel alignment

Toe-in (+) / Toe-out (-)	mm [°]	+2.0±3.0
Camber		WSM

Torque wrench settings 760, 2.8i 1988 to 1990

Cylinder head - stage 1	Nm	60 ³
- stage 2	Nm	Loosen, then 20 ³
- stage 3	Nm	+ 106° ³
- stage 4	Nm	Warm up & cool, + 45° ³
Big-end bearings	Nm	No. 1 bolt: 25 ⁴
Main bearings	Nm	30 ⁵
Clutch cover	Nm	—
Flywheel [driveplate]	Nm	45 to 50 N
Front hubs	Nm	100 + 45°
Rear hubs	Nm	30 + 90° ⁶
Wheel nuts / bolts	Nm	85
Spark plugs	Nm	12

Capacities 760, 2.8i 1988 to 1990

Engine oil & filter	litres	6.5
Gearbox - 4-speed [5-speed]	litres	—
Automatic transmission - refill	litres	3.9
Final drive	litres	1.6
Cooling system	litres	10.0
Fuel tank	litres	80. Estate: 60

Notes and Illustrations

¹1.4kW: 75 / 11.5. 2kW: 65 to 95 / 11.5. Hitachi: 300 / 8.8

²1.4kW: 625 to 800 / 4.5. 2kW: 700 to 800 / 4.5. Hitachi: 880 / 3.0

³90 ▶: fixed washer bolts: 60, slacken, 40 +160 to 180°

⁴No. 2 bolt: 25 + 75°. No. 1: + 75°. 1 & 2: 50

⁵Loosen, then 30 to 35 + 73 to 77° WSM

⁶Estate: WSM

1: Idle speed 2: CO / Mixture

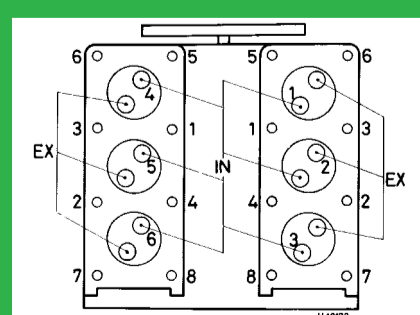
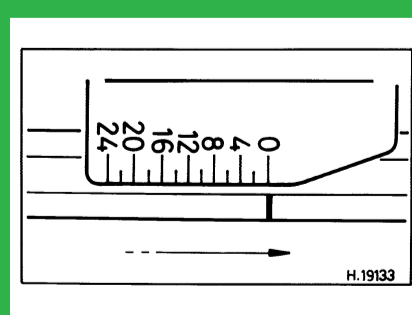
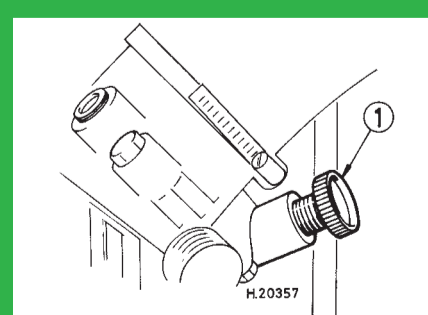
2849 cm³2849 cm³

LH2.2-Jetronic

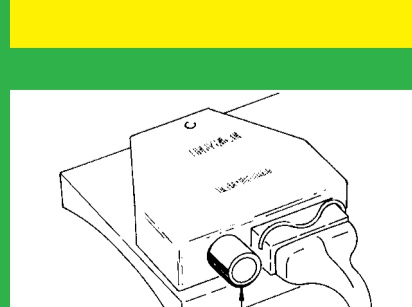

LH2.2-Jetronic