

Service Manual

1989-1998

Daihatsu Hijet

S100 -S140

Multi-Purpose Utility Vehicle

2WD and 4WD

Pickup and Van

660 CC motor

Includes Engines

EF-NS EF-ES EF-TS

Daihatsu HiJet Factory English Service Manual

English Full Version

2WD & 4WD

Truck & Van 660cc

AT-MT Models

Factory Service Manual Edition

1990 to 1998 Models

Contents

Chapter 1

Vehicle Identification.....13~28

- Vehicle Types
- My Vehicle ID Plate Location & Meaning of ID Plate
- VIN Decoder (Truck)
- VIN Decoder (Van)
- VIN Decoder (Panel Van)
- Rear Differential Decoder
- Manual Transmission Decoder
- Engine Types
- Tire Size and Air Pressure
- Wheel Sizes & Replacements
- 4WD Towing Instructions
- Fuse Box
- Vehicle Lift Positions
- Vehicle Jacking Positions

Chapter 2

General Maintenance.....29~46

- Air Filter Replacement & Part Numbers
- Spark Plug Replacement & Part Numbers
- Ignition Timing
- Ignition Circuits & Coil Testing
- Ignition Coil, Spark Plug Wire Part Diagrams
- Distributor Points Setting

- Idle Setting & CO-HC Level
- Transmission Oil Replacement & Capacities
- Engine Oil & Capacity Chart
- Oil Filter
- Driveline Inspection & Rear Differential Oil
- Front Wheel Alignment
- Camber & Caster Specifications
- Valve Adjustment

Chapter 3

Steering System.....47~68

- Steering Wheel Type & Components
- Steering Column & Components (MT Manual Vehicle)
- Steering Column Removal
- Tilt Steering Column Components
- Rack & Pinion Gearbox Removal
- Rack & Pinion Gearbox Overhaul
- Tie Rod Ends Removal and Installation
- Rack & Pinion Parts Diagram & Part Numbers
- Tie Rod & Center Arm Parts Diagram & Part Numbers

Chapter 4

Suspension.....69~84

- Tire Size & Air Pressure
- Alignment
- Strut Components
- Front Strut Removal & Replacement
- Rear Shock Absorber Replacement
- Rear Leaf Spring Components
- Rear Coil Spring Suspension (Van)
- Rear Coil Spring & Differential Removal
- Rear Lateral Control Rod Diagram
- Front Strut & Parts
- Rear Leaf Spring Suspension Parts
- Front Suspension Parts

Chapter 5

Brake System.....85~104

- Brake Pedal & Bracket Diagram
- Master Cylinder Breakdown Diagram
- Master Cylinder Type (Standard-ABS) & Rebuild
- Parts: Master Cylinder Van-Truck
- Parts: Brake Booster
- Front Disk Brake System 2WD
- Front Disk Brake System 4WD
- Front Caliper Breakdown Diagram & Parts Listing
- Rear Drum Brake System & Parts
- Parking Brake Diagram & Parts
- ABS Control Unit

- **ABS Computer**
- **ABS Complete Control Circuit Schematic 2WD**
- **ABS Complete Control Circuit Schematic 4WD (Including Diff-Lock)**

Chapter 6

Cooling System.....105~118

- **Radiator & Components (Truck)**
- **Radiator & Components (Van)**
- **Radiator Removal**
- **Radiator Fan Testing & Relay Circuit**
- **Radiator Thermo Control Switch Test**
- **Thermostat Replacement**
- **Thermostat Testing**
- **Water Pump Removal**
- **Water Pump Schematic & Parts EFGS, EFZS, EFRS**
- **Water Pump Schematic & Parts EFNS, EFES, EFTS**
- **Radiator & Related Parts Per Series (All Series)**
- **Additional Major Part Numbers**

Chapter 7

Engine.....119~158

- **Engine Series Covered**
- **Engine Mounts**
- **Engine Mount Inspection & Limits**
- **Engine: Exploded Component View**
- **Diagnostic Connectors & Oil Specification**
- **Timing settings**
- **Timing Belt Components & Replacement**

- **Timing Belt Parts**
- **Head Gasket Removal & Replacement**
- **Head Gasket & Valve Cover Gasket Parts**
- **Valve Train Stem & Oil Seal Parts**
- **Oil Pump Replacement**
- **Oil Pump Overhaul**
- **Oil Pump Parts**
- **Oil Filter & Parts**
- **Piston & Block Overhaul**
- **Engine Parts Replacement Including Oversize Pistons & Rings**
- **Engine Miscellaneous Guide Pins & Part Numbers**

Chapter 8

Starter & Alternator.....159~164

- **Starter**
- **Starter Circuit & Specifications**
- **Alternator**
- **Charging Circuit & Specifications**

Chapter 9

Fuel System.....165~184

- **Carburetor Assembly**
- **Carburetor Removal & Replacement**
- **Carburetor Setting and CO HC Levels**
- **Carburetor Component Diagram**
- **Fuel Filter & Part Numbers**

- Fuel Tank & Components (Van) Base Carbureted
- EFI Fuel Injection
- EFI Fuel Injection Components & Parts Location
- Engine Control Computer Connector Pin Guide
- Fuel Pump: Mechanical (Head Type), & Electric (Body or Tank)
- Fuel Lines EFNS (Truck)
- Fuel Lines: EFES
- Fuel Lines: Turbo-Vehicle
- Fuel Lines: EFNS (Van)
- Fuel Lines: EFES (Van) Fuel Injected

Chapter 10

Emission Control & Vacuum System.....185~192

- EFNS Series Vehicles
- EFNS Truck
- EFNS Van
- EFES Series Vehicles
- EFES Truck
- EFES Van
- Others

Chapter 11

Differentials-Driveshaft(s)-Axels.....193~220

- Front Differential Components 4WD
- Front Differential Oil Seal Replacement
- Front Differential Mounting System
- Rear Differential Identification and Axle Codes
- Standard Rear Differential Components
- Rear Differential With Diff-Lock Option
- Rear Differential Front Oil Seal Replacement
- Rear Diff-Lock Actuator Removal & Replacement
- Rear Diff-Lock Actuator Vacuum System
- Front Driveshaft Removal & Inspection
- Rear Driveshaft Removal & Inspection
- Rear Axle Removal Tools
- Rear Axle Removal
- Rear Axle Bearing & Oil Seal replacement
- Front Axle (CV Joint) Overhaul
- Driveshaft Parts
- Front Axle Hub Parts
- Front Axle Parts
- Rear Axle Parts

Chapter 12

Clutch System.....221~230

- Clutch Cable Replacement & Adjustment
- Clutch Replacement
- Clutch Parts

Chapter 1

Vehicle Identification

- **Vehicle Types**
- **My Vehicle ID Plate Location & Meaning of ID Plate**
- **VIN Decoder (Truck)**
- **VIN Decoder (Van)**
- **VIN Decoder (Panel Van)**
- **Rear Differential Decoder**
- **Manual Transmission Decoder**
- **Engine Types**
- **Tire Size and Air Pressure**
- **Wheel Sizes & Replacements**
- **4WD Towing Instructions**
- **Fuse Box**
- **Vehicle Lift Positions**
- **Vehicle Jacking Positions**

Vehicle Types

Truck

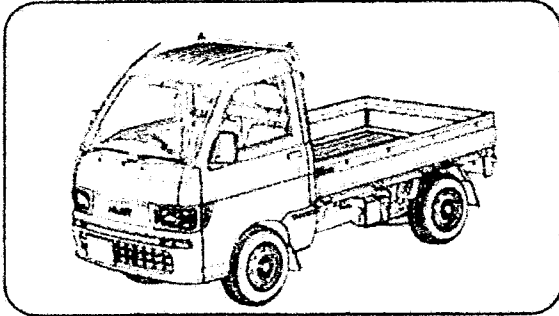

Van

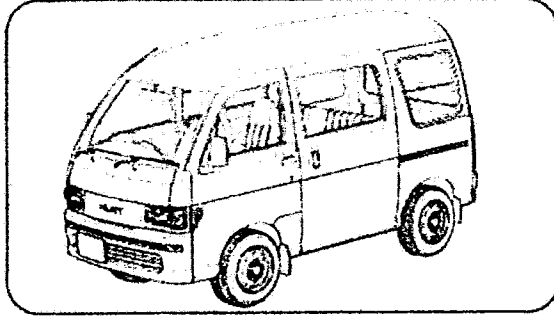

Dump

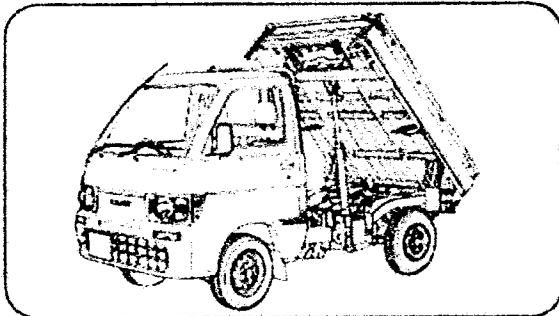

Van (Cosmic Roof)

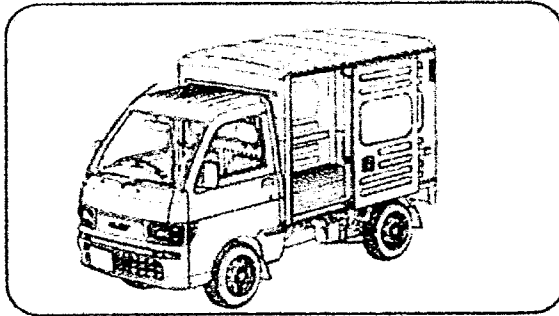
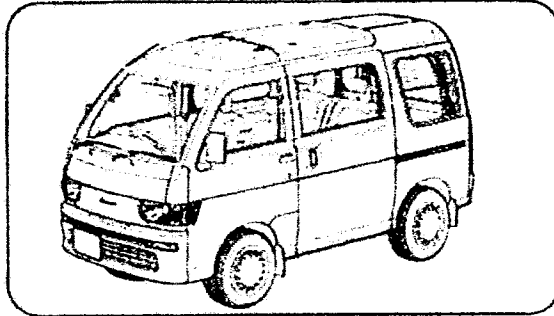

Panel Van (Delivery)

My Vehicle

Vehicle ID Plate

Where is my vehicle Plate?

1990~1991 Generally Located Behind Passenger Seat Left Pillar. If Not Look Below The Drivers Seat (Behind Your Legs).

1991~2000 Behind Drivers Right Side on Pillar (Head Level), or Under or Near Passenger Seat

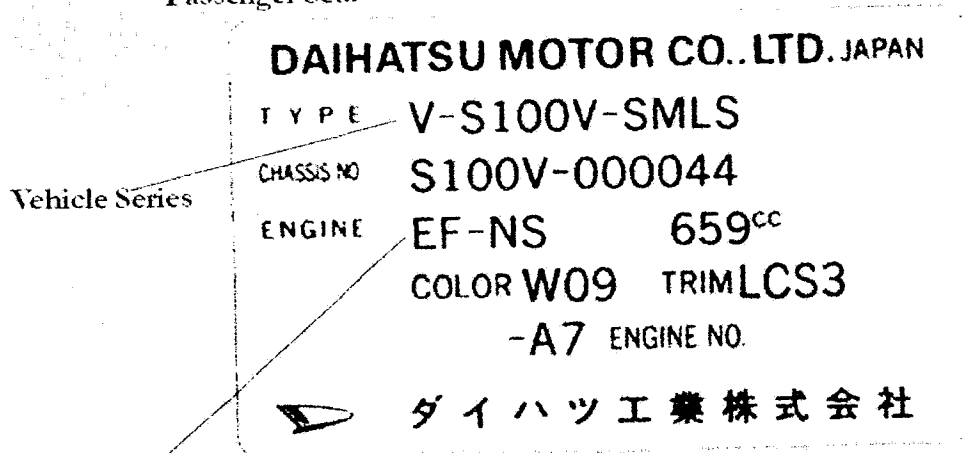

Note: This CODE is Important for This Book! You Need the Chassis Number Engine Series (Example: EFNS) to Match Specifications and Order Parts.

What year is my Truck/Van?

Japanese Vehicles Do NOT Have a Vehicle Model Year Like Most Countries, They Have a Vehicle TYPE. All Parts & Maintenance is Determined By This Code. If You Want to Know Year of Manufacturer Check The Bottom Seat belt Tag.

1989 and Earlier Daihatsu Plate Location

Here (Glove Box)

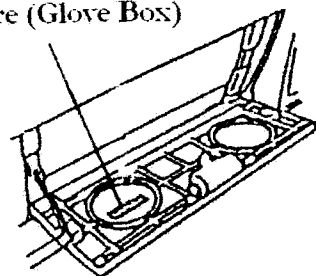

Possibly Here Right Side of Tray



Note: Pre-1989 Was A Sticker and Can be Lost Easy. Important to Keep Paperwork

VIN Decoder

Truck

Truck

Sample: VIN (Truck)

V - S 1 0 0 P - P M R S

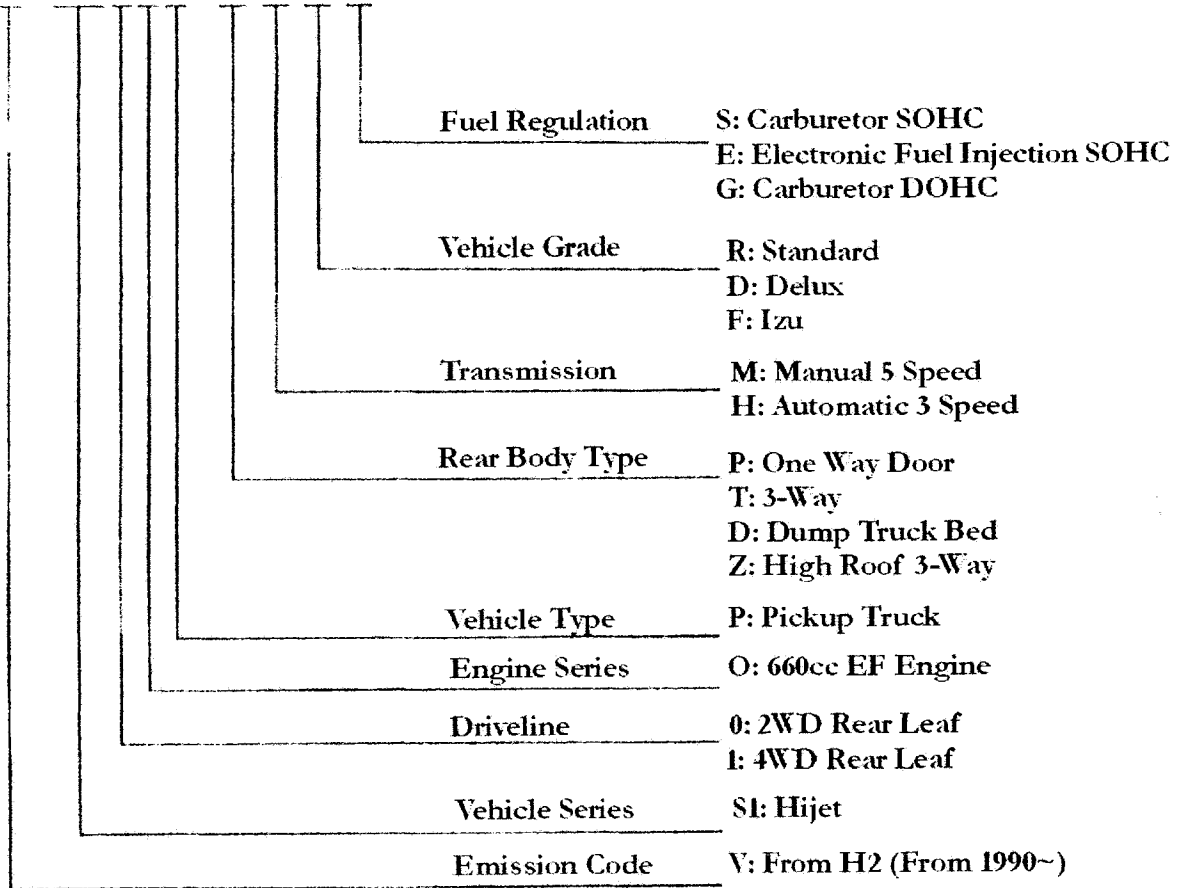

VIN Decoder

Van

Van

Sample VIN (Van)

V - S 1 0 0 V - S M L S

Fuel Regulation	S: Carburetor SOHC E: EFI Non-Turbo SOHC T: EFI Turbo SOHC G: Carburetor DOHC F: EFI Non-Turbo DOHC Z: EFI Turbo DOHC
Vehicle Grade	L: 2 Seater or LX R: Standard D: Delux G: MX Q: HX
Transmission	M: Manual 5 Speed H: Automatic 3 Speed
Cabin Type	S: Normal Roof 5 Door Z: High Roof 5 Door F: High Roof 4 Door
Vehicle Type	V: Van W: Deck Van
Engine Series	O: EF Series
Driveline	0: 2WD Rear Leaf 1: 4WD Rear Leaf 2: 2WD Rear Coil 3: 4WD Rear Coil 4: 2WD Electric Vehicle
Vehicle Series	S1: Hijet
Emission Code	V: H2 (From 1990~)

VIN Decoder

Panel Van

Panel Van

Sample VIN (Panel Van)

V - S 1 0 0 C - C M L S

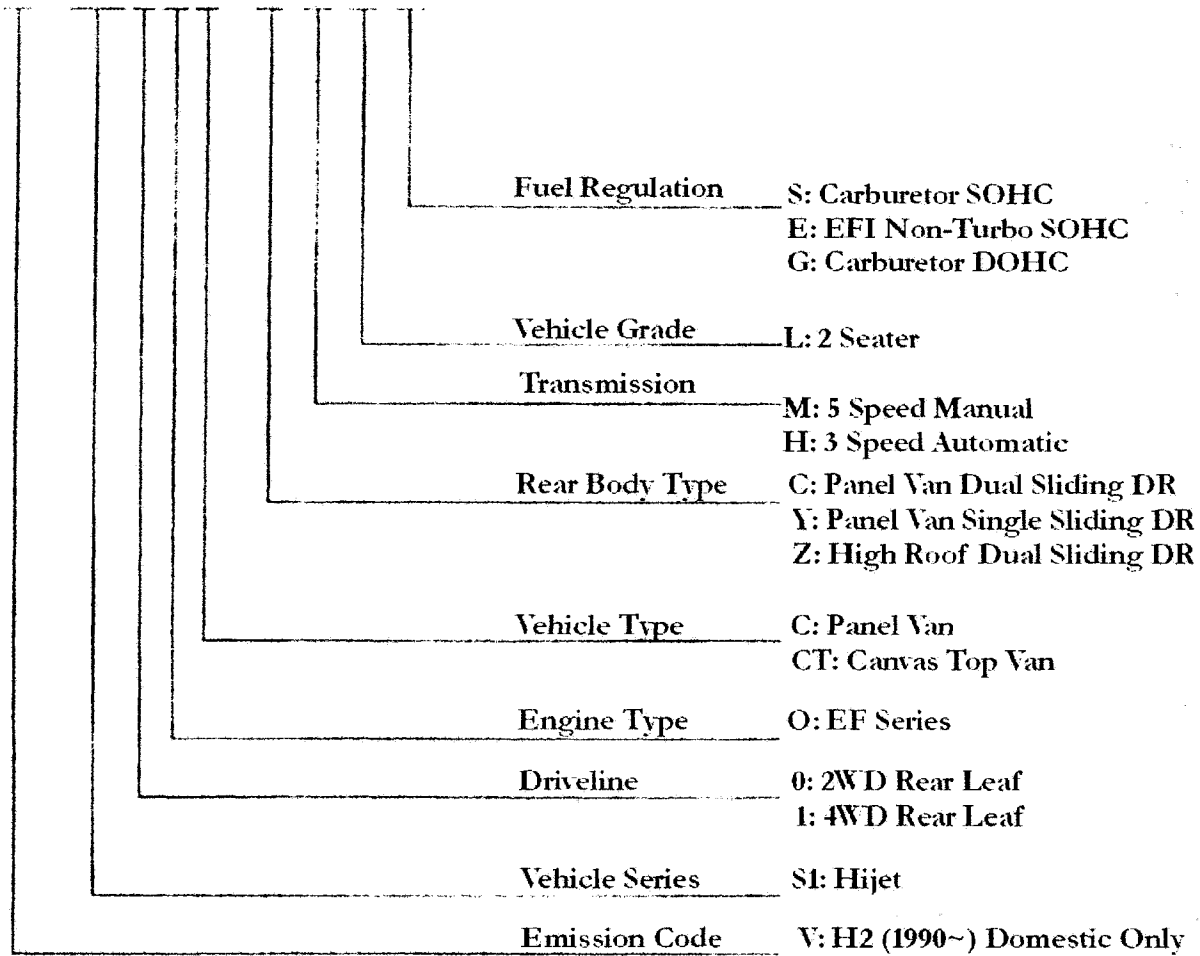

Differential

Rear Axel Codes

Example: 50=Ratio 5.571 S120V EFTS Series

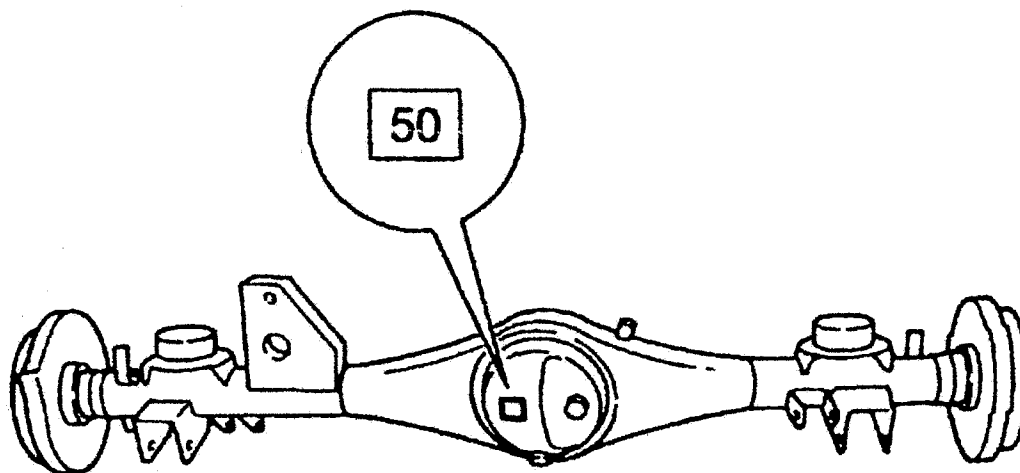

Gear Ratio	Mark	Series
6.666	01-03	SP100P
6.285	05	SP100P/SP110P
6.666	09-11-13	SP110P
6.285	17	SV100
6.666	61-21-62	SV100V/S100V
6.285	29	EFES S120V
5.571	49-50-51-52	EFTS S120V
6.666	33-37	EFES
5.875	41~48, 53	S130V EFES EFTS

Transmission Identification

Manual Transmission

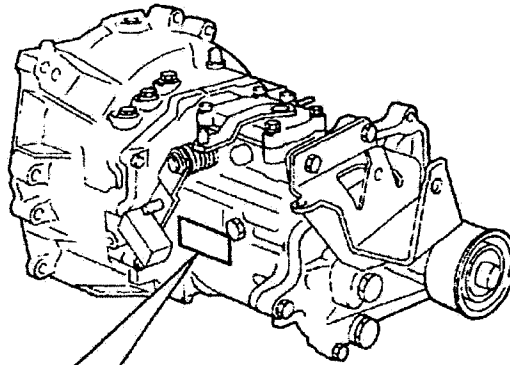

Example: 214=2WD Non-Turbo Van

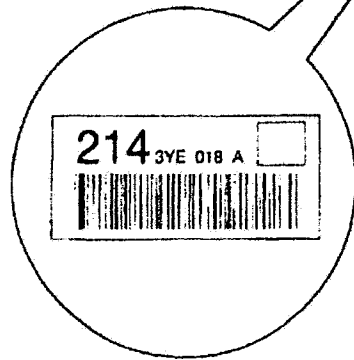

Drivetrain	Type	Mark
2WD	Truck/Van	213
2WD	Atrai	214
2WD Turbo	Atrai	220
4WD PT 4WD	Truck/Van	P19 H-L
4WD Normal	Truck/Van	P10
4WD PT 4WD	Truck	P11 PTO
4WD PT 4WD	Van	P12
4WD PT 4WD	Truck/Van	P20
4WD Turbo	PTO Option	P28
4WD Turbo Muti Select 4WD		A20

Engine Series

Engine Types

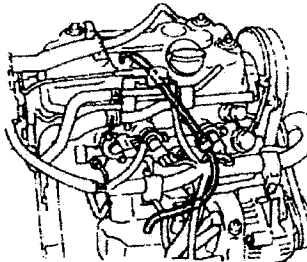
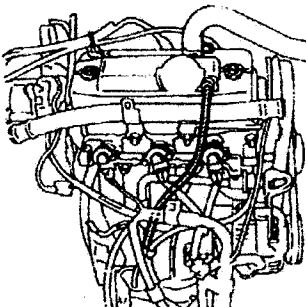
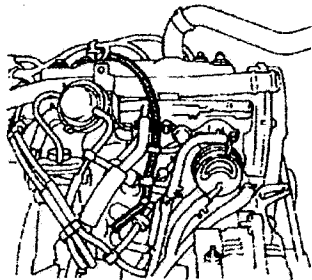
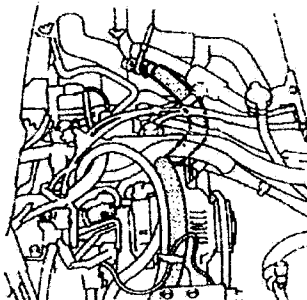
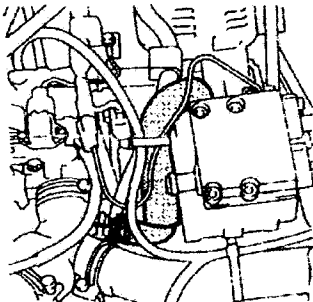
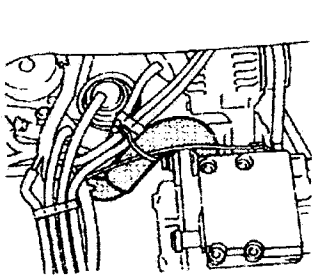

EF-NS

EF-ES

EF-TS

Tire Size and Air Pressure (kg.cm)

Check tire pressure at regular intervals

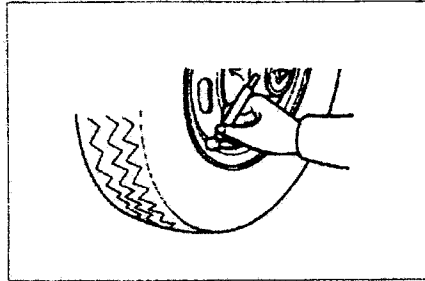

Tire Pressure Guide

Vehicle Series		Size	Air (kg.cm)	
			F	R
S100P, S110P S100C, S110C S100CT, S110CT		5.00-12-4	2.0	2.4
		5.00-12-6		
		145R12		
S100V	AT	5.00-12-4	2.2	2.4
	MT	5.00-12-6	2.4	2.4
	All	145R12	2.4	2.6
S110V		5.00-12-4	2.4	2.4
		5.00-12-6	2.4	2.4
		145R12	2.4	2.6
S120V		145R12	2.4	2.4
		155R12	2.2	2.2
		165/70R13	2.4	2.4
S130V	ZMGE, ZHGE	145R12	2.4	2.4
	FMQE		2.6	2.6
	ZMGE, ZHGE, ZMGT	155R12	2.2	2.2
	FMQE		2.4	2.4
	All	165/70R13	2.4	2.4
T125/90 D12			4.2	



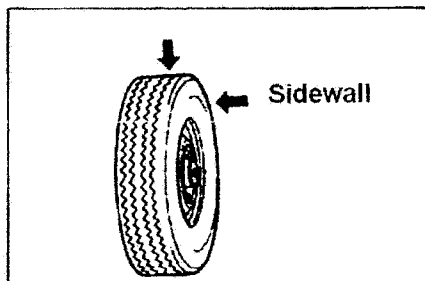

Tread

Check uneven tread wear and cracks in the sidewall. Replace if necessary





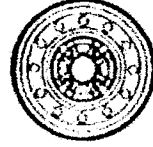



Wheels & Replacements

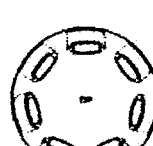

Steel Wheels

 3.00B X 12 42611-87533-000 (YUNO)	 4.00B X 12 42611-87541-000 (YUNO) 42611-87542-000 (YUNO)	 4.00B X 12 42611-87533-000 (YUNO)	 4.50J X 13 42611-87538-000 (CHUC)
 4.00B X 12 (SUNATSUBU) 42611-87539-000	 4.50J X 13 42611-87540-000 (CHUC)		

Wheel Covers (Hub Caps)

 13inch 42602-87509-000	 12inch 42603-87508-000	 12inch 42602-87512-000	 13inch 42602-87511-000
 12inch 42602-87515000	 13inch 42602-87516-000		

Steel Wheels

 4.00B X 12 42611-87541-000 (YUNO)	 4.00B X 12 42611-87533-000 (YUNO)
---	---

4WD Towing Instructions

Towing of 4WD vehicles

4WD vehicles must always be towed in 2WD position. Failure to do so can cause damage to both vehicles.

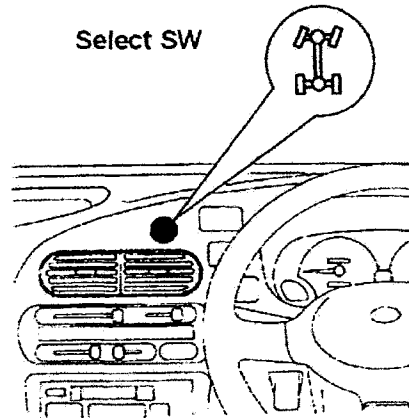

Place Transfer Shift Control Lever in Neutral Position

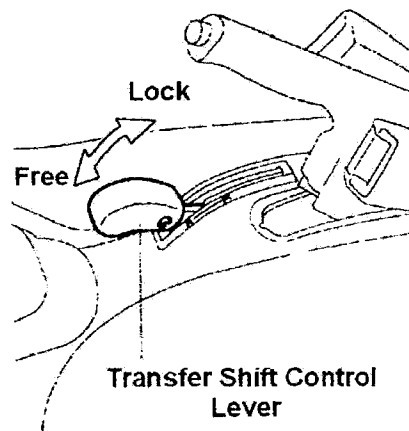
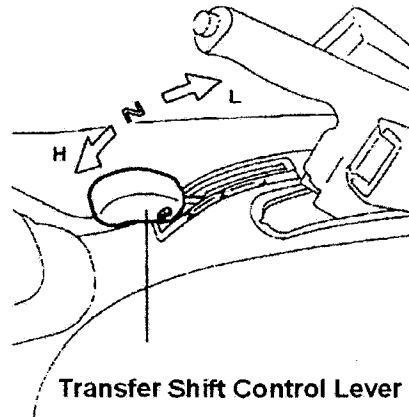

Fuse Box

Typical Unit

Truck & Van

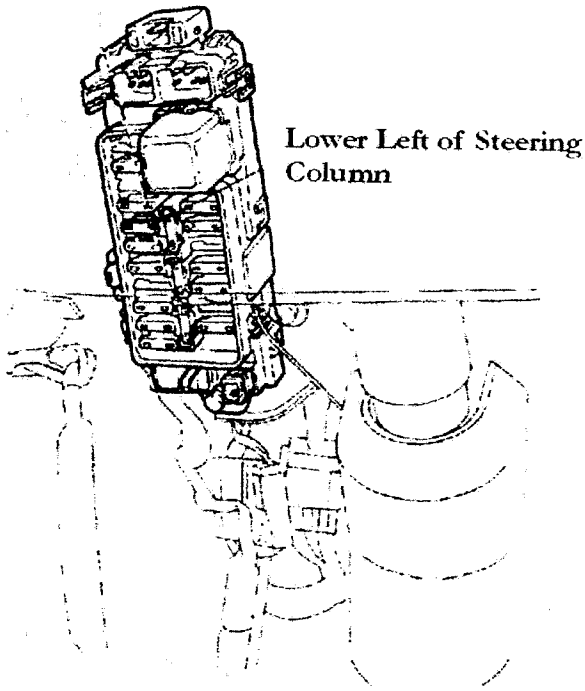

Fuse Box

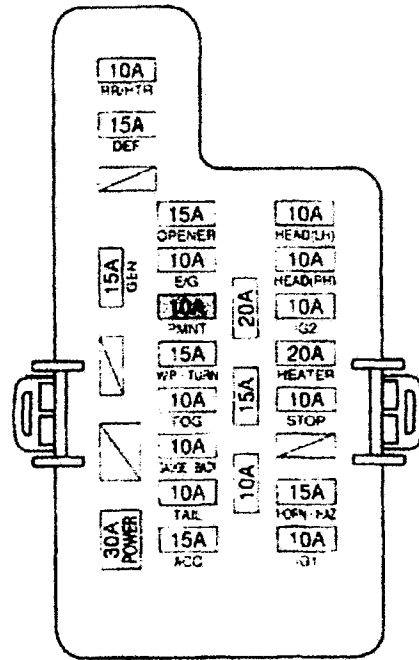

Lift Posistions

Front

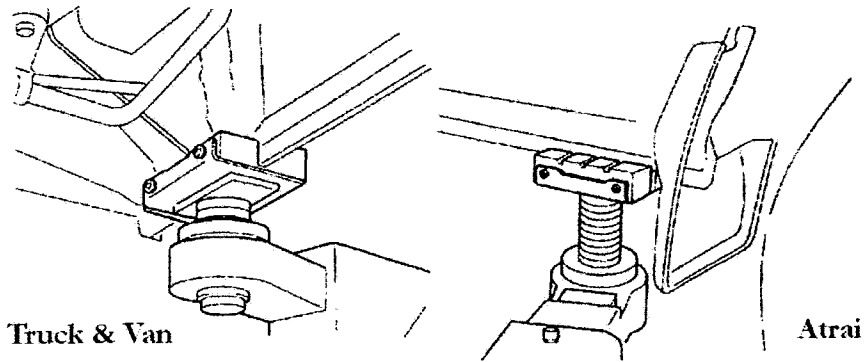

Rear

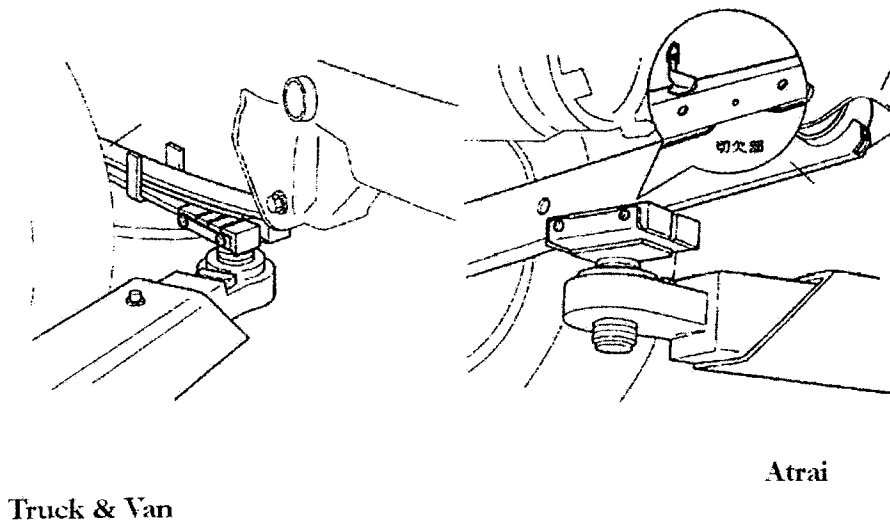

Jacking Positions

Front

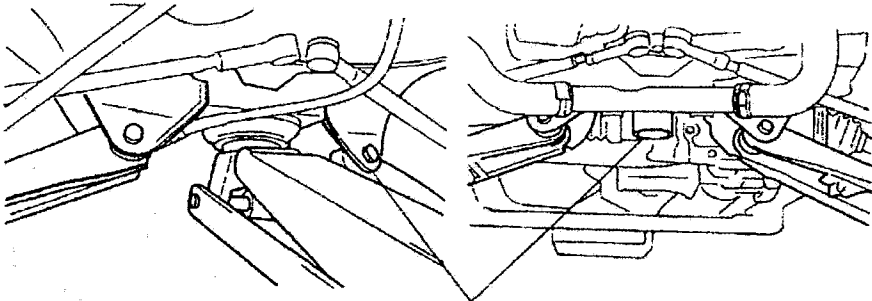

Front Suspension cross member

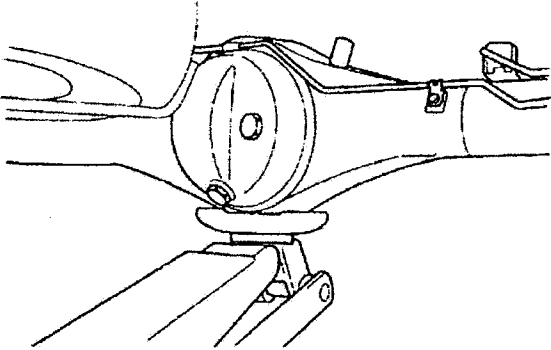

Rear

Support both Axels on each side with proper jack stands

Chapter 2

General Maintenance

- **Air Filter Replacement & Part Numbers**
- **Spark Plug Replacement & Part Numbers**
- **Ignition Timing**
- **Ignition Circuits & Coil Testing**
- **Ignition Coil, Spark Plug Wire Part Diagrams**
- **Distributor Points Setting**
- **Fuel Filter Replacement & Part Numbers**
- **Idle Setting & CO-HC Level**
- **Transmission Oil Replacement & Capacities**
- **Engine Oil & Capacity Chart**
- **Oil Filter**
- **Driveline Inspection & Rear Differential Oil**
- **Front Wheel Alignment**
- **Camber & Caster Specifications**
- **Valve Adjustment**

General Maintenance

Air Filter

CO Levels must be below 1.5% and HC levels at below 800ppm

A dirty air filter can casue the oxygen sensor to mis-adjust due to air restriction. A clean air filter will allow the system to blance correctly.

Note: Do not run vehicle without an air filter. Damage to the system will occur

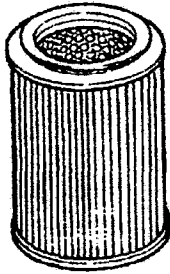

Truck

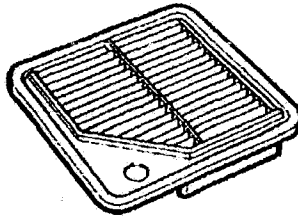

Van (Turbo)

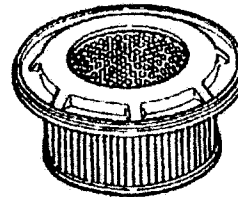

Van (non-Turbo)

Air Filter Part Numbers

S100-S110 Truck
EF-NS, EF-ES, EF-GS
Part# 17801-87512-000

S120-S130 Truck
EF-TS, EF-RS
Part# 17801-87514-000

S100-S110-S120-S130 Van
EF-NS, EF-ES
Part# 17801-87515-000

S100-S110-S120-S-130 Van
EF-GS, EF-ZS
Part# 17801-87516-000

General Maintenance

Spark Plug Replacement

EF-TS

- Remove side under cover
- Remove spark plug wires
- Remove Plug 1 & 2

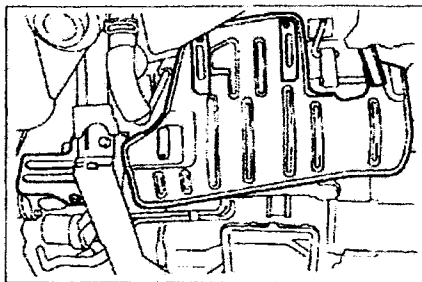

Prepare an extension socket setup as in the diagram on the right

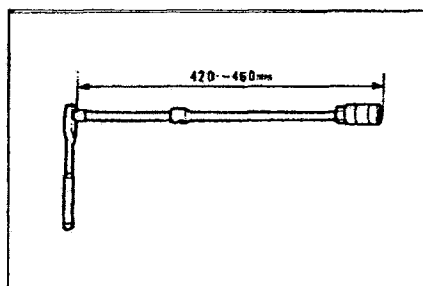

To reach plug No. 2 use the diagram on the right for guidance.

Remove and install new plugs as listed in the box below.

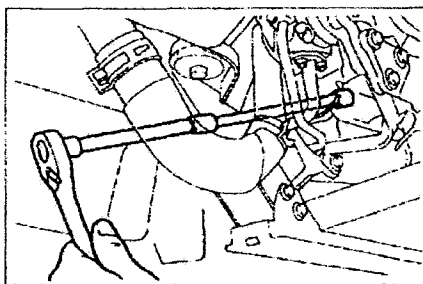

Spark Plug Information

Engine Series	Spark Plug		Plug Gap (mm)
	Denso	NGK	
EFNS	W16DTR-S	BPR5EK-B	0.9~1.0
EFES	QL20TR-S	BCPR6EKD	
EFTS	W20DTR-S	BPR6EK-B	

Note: Installation of spark plugs will differ slightly between the different vehicle types.

Note: Check vehicle specific tune-up specifications on the sticker placed in the engine compartment.

General Maintenance

Ignition Timing

Timing	(BTDC/RPM)
EF-NS	7°/950
EF-ES	5°/850
EF-TS	10°/900

Note: Point Gap Distributors:(All) 0.2~0.4mm

Clear access to check timing. Make sure no wires will touch any moving parts.

Caution: Be careful of electrical discharge

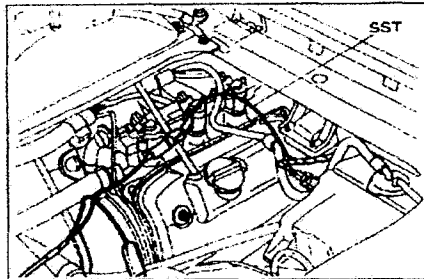

Remove distributor vacuum hoses and plug

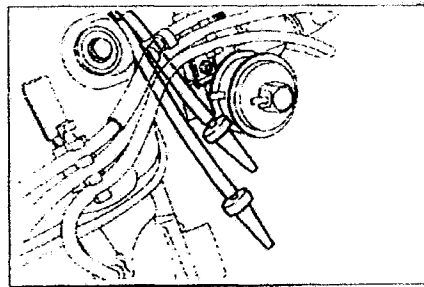

While engine is running verify timing
Example: EF-NS series engine 7°/950 RPM

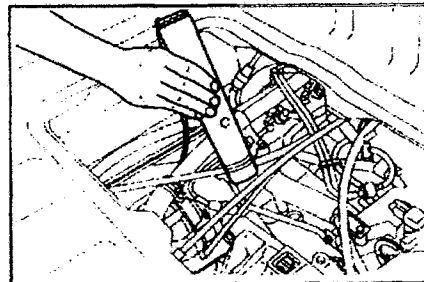

Move distributor (slowly) to set timing.
Allow engine to adjust itself before moving timing setting too rapidly.

Note: If timing is slightly erratic, remove and inspect distributor cap & rotor. A dirty cap & rotor can cause erratic timing and poor fuel economy

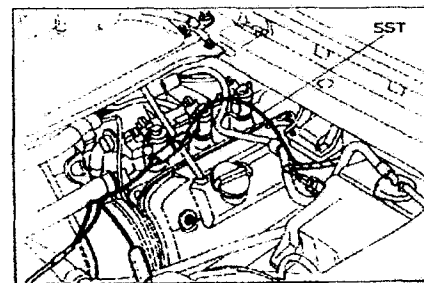

General Maintenance

Ignition Circuit & Coil

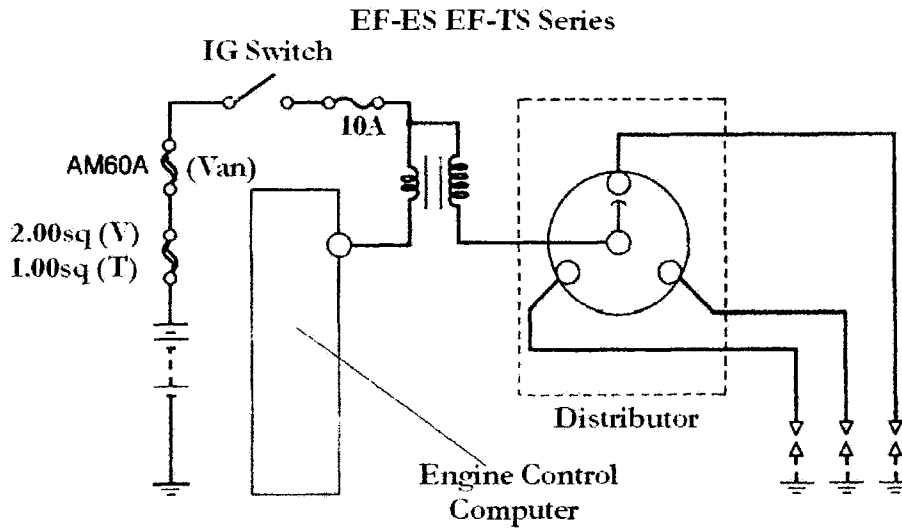
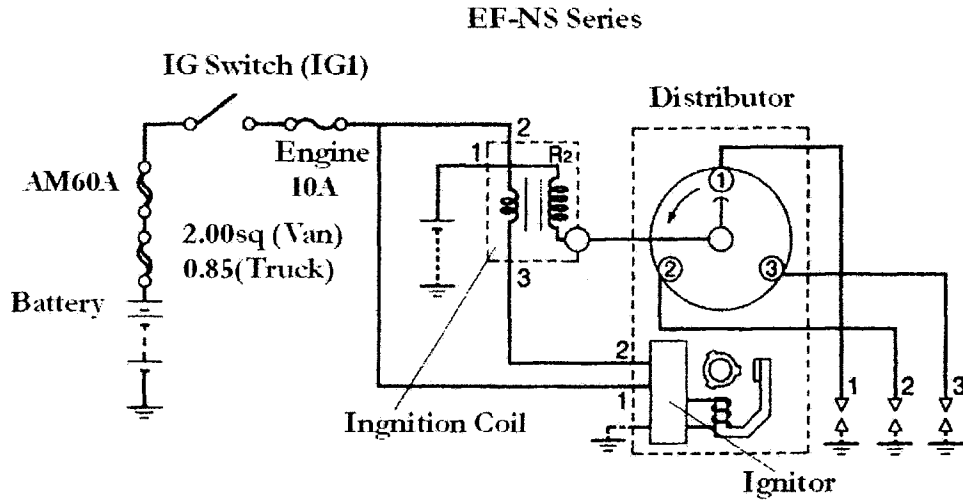

Ignition Coil Test

1. IG Switch On
2. Use a Voltmeter and Check Power to Connector

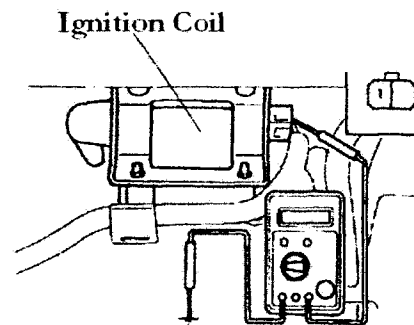

General Maintenance

Tune-Up parts

EFGS, EFZS, EFRS

Coil Part Numbers

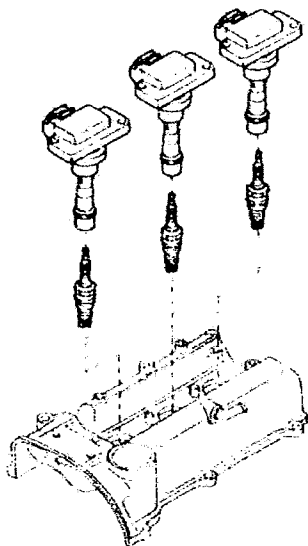

EFGS-EFZS #90048-52117-000(3)
EFRS #90048-52119-000(3)

EF-NS, EF-ES, EF-TS

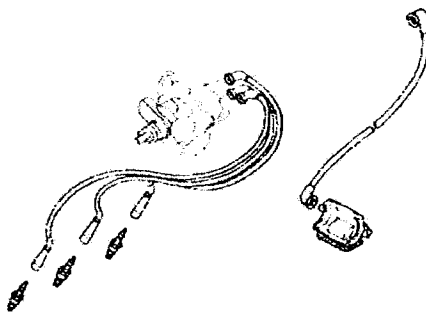

Ignition Coil
EF-TS S-120, S-130
Part# 90048-52108-000
EF-NS, EF-ES S-100, S-110
Part# 90048-52106-000
EF-GS, EF-ZS S-100, S-110, S-120, S-130
Part# 90048-52117-000

Spark Plug Wire Set
EF-ES VAN S-100, 110, 120, 130
Part# 19901-87D90-000
EF-NS, EF-ES, EF-TS Truck
S-100, S-110, S-120, S-130
Part# 19901-87D91-000

Note: Spark Plugs are Listed in Beginning of This Book

General Maintenance

Fuel Filter

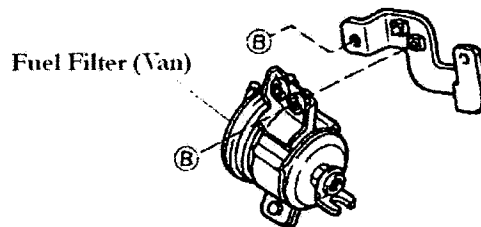
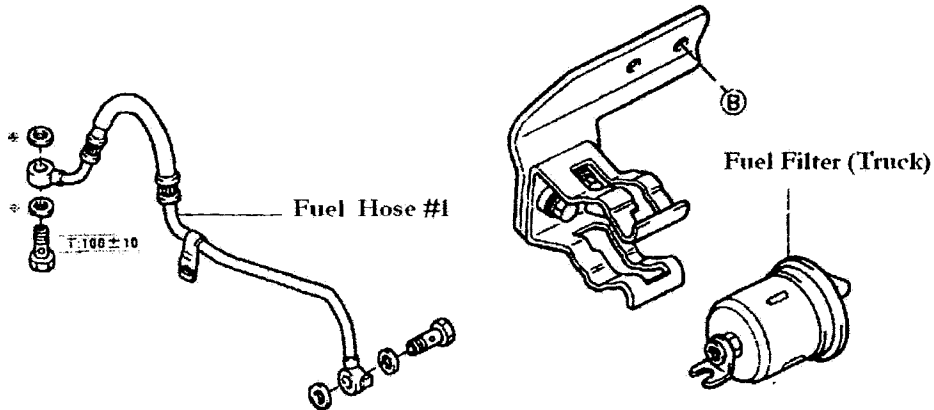

Fuel Pump Relay Location
Van

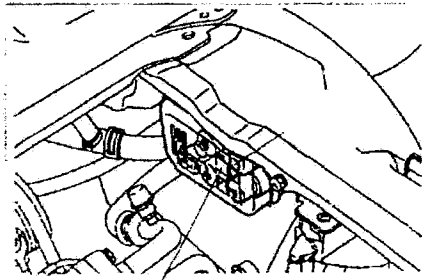

Fuel Pump Relay Location
Truck

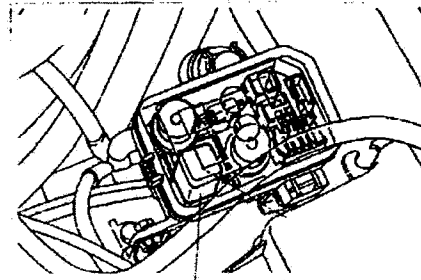

Note: Always Remove Fuel Relay When Changing Fuel Filter (FI Engines)

Note: Fuel Pumps Ohm Rating 0.2~3.0 Ohm

Fuel Filter Part Numbers

EF-ES, EF-TS, S100-S110-S120-S130 Part# 23300-87508-000

EF-ES, S100-S110-(Truck) Part# 23300-87509-000

EF-NS, EF-GS, S100-S110-S120-S130 (Truck) Part# 23300-87502-000

EF-NS (Van) Part# 23300-87510-000

General Maintenance

Idle Adjustment & CO HC Levels

EF-NS

To Set Idle Adjustment The Idle Adjustment Screw Must Be Turned In Either Direction

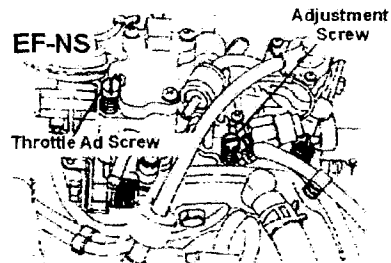

EF-ES

EF-ES Series Engines Idle System is Computer Controlled

James Note: Idle Curcuit Trouble is 99% of the Time the ISC Valve
ISC is Connected to ECU (Rotary ISC) (RSO & RSC Connection)

EF-TS

EF-TS Series

Using a SST connector Pn#09991-87604-000
attach tachometer.

Set Idle to 900+/-50 RPM

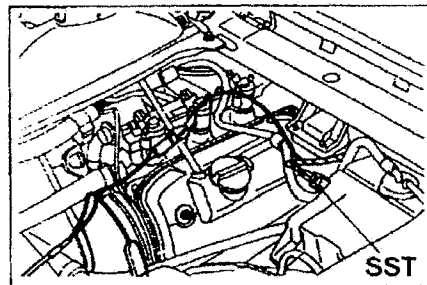

CO-HC Levels

EF-NS (Use Mixture Screw to Adjust)

Idle CO-HC Level

CO 1.5+/-1.0% to -0.5%

HC 900 PPM (Parts Per Million) or Less

EF-ES & EF-TS

Idle CO-HC Level

Co 1.5+/-1.0% to -0.5%

HC Below 900 PPM

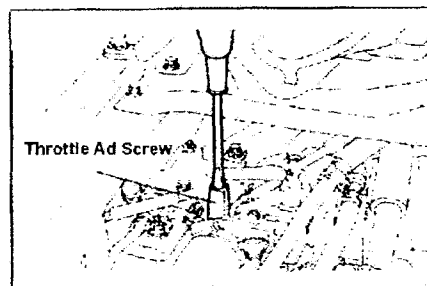

SST=Service Support Tool

General Maintenance

Transmission Oil

Look for leaks around the common case assembly areas. If a constant drip is detected first torque to spec. If leak or drip continues remove transmission and replace seals.

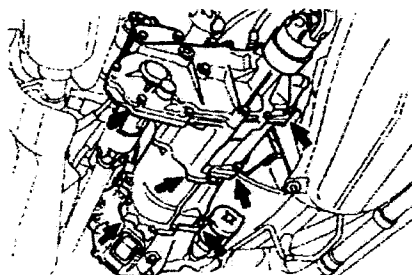

Manual Transmission
Remove plug:
Level should be within 0~5mm

Capacity:
2WD 1.1 Liters
4WD 2.3 Liters (Including Transfer Case)

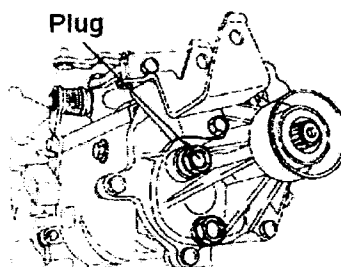

Automatic Transmission
#Check while warm (70~80C)#

Holding down the brake pedal, shift from [P] to [L] 1~2 times to make sure fluid is flowing.

Return to Park [P] Check fluid level
(If dis-colored or smells burnt replace)

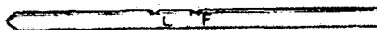

Transfer Case (Automatic Trans AT Vehicle)
Remove plug and chck level to: 0~5mm
Capacity: 1.6 Liter

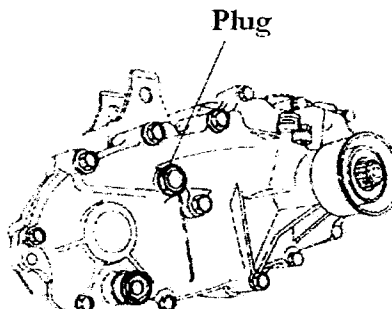

Engine

Engine Oil

Engine Series	EF-NS, EF-ES	EF-TS
SAE	5W-30	10W-30
API	SE	SF
Capacity	3.1 Liters	3.1 Liters
Oil Change	10.000K or 6mo	10.000K or 6mo

*Note: Do NOT use heavier grade oils. Heavier oils can increase pressure and cause gasket failure

Engine Condition:

Before performing engine work it is important to check oil condition. Oil is the best indicator to the internal condition of the engine.

Dirty oil will impede engine performance and can cause premature engine failure.

Oil Filter maximum use: 10,000 Kilometers

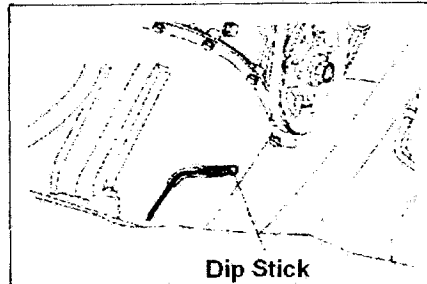

Dip Stick

General Maintenance

Oil Filter

Oil Filter

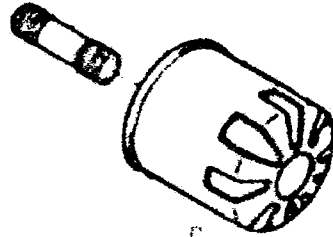

Denso
Tokyo Roki

Oil Filter Part#

EF Series S100-S110-S120-S130

PN: 15601-87204-000 or PN: 15601-87703-000

Cross Reference to:

Suzuki Part #16510-81403

Mazda Part #AY01-14-300A

General Maintenance

Driveline Inspection

Check Driveshaft for excessive play
Inspect U-Joints: Replace if necessary

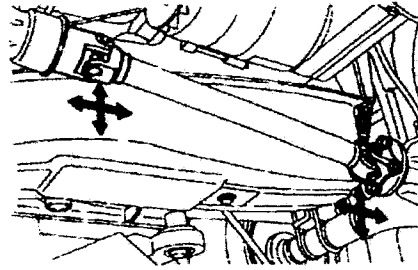

Inspect CV Joints for broken dust boots
Replace if cracked or torn

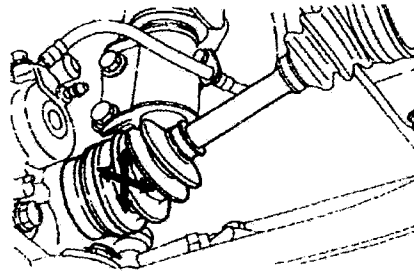

If a vibration is detected in the driveline
remove driveshaft and check for round-out

Maximum round-out Below 1.0(mm)

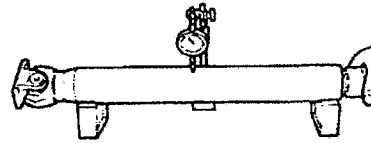

Axel Shafts should be removed and
inspected every 75,000 Kilometers
Check for broken teeth. Replace if
necessary

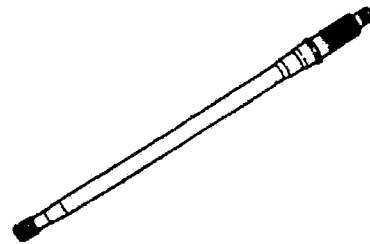

Differential Oil Inspection

Remove plug: Oil Level 0~5(mm) below plug
level.

Replace Oil every 25,000 Kilometers

Capacity

Rear: 1.3 Liters

Front: 0.61 Liters

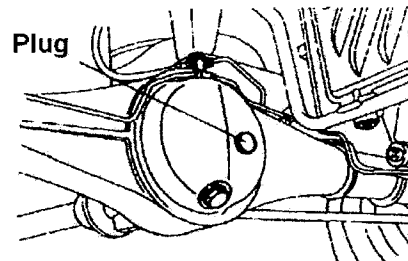

General Maintenance

Alignment

Note: Make Sure Tire Size and Air Pressure
Are Correct Before Alignment

1. Loosen Tie Rod End Lock Nut

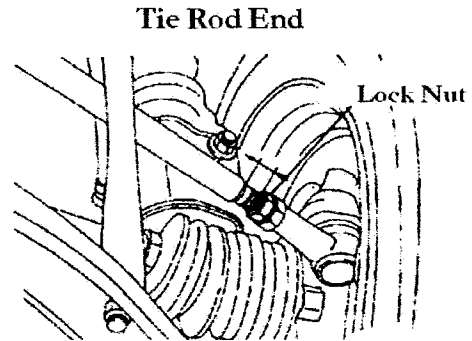

2. Measure Toe In

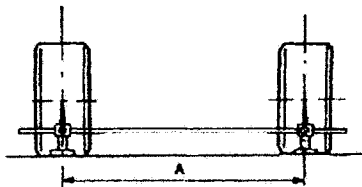

Specifications: (All) 0.0+-1.0mm

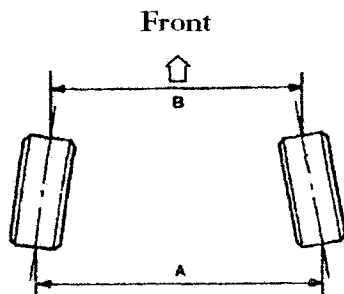

3. Set Toe In to Specifications
4. Torque Tie Rod End Lock Nut to T: 450+-100kg.cm

Note: After Setting Torque Once More Verify Toe In

5. Set Camber & Caster

General Maintenance

Camber & Caster

Note: Use an Camber & Caster Gage to Set Specifications

Camber Specification: $0^{\circ}15' + -45'$

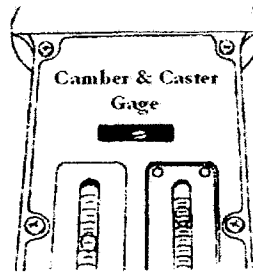

Camber & Caster

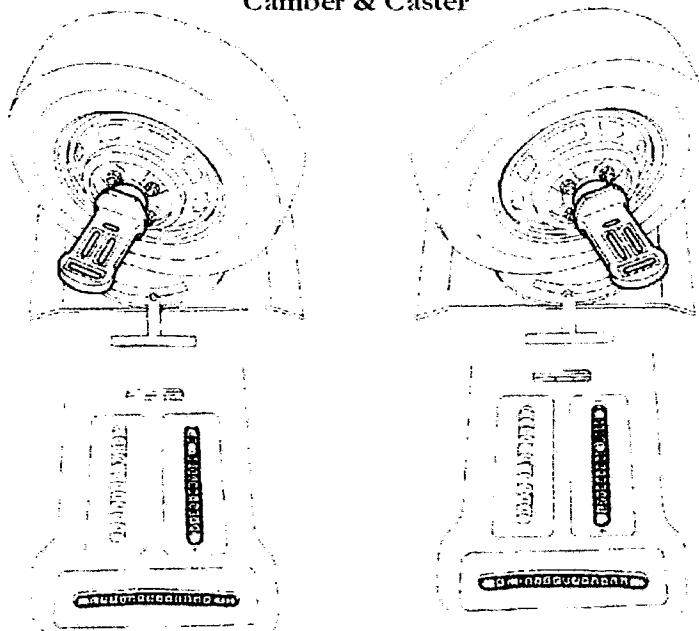

Specifications

Caster:
 $3^{\circ}08' + -1$ (Truck)
 $3^{\circ}04' + -1$ (Van)
King Pin Degree $13^{\circ}03' + -1$

Front Side Slip= In 5mm~Out 5mm

Note: (*)=Degree

General Maintenance

Valve Adjustment

1. Remove Air Cleaner (EF-TS)
 2. Remove Valve Cover & Discard Gasket
 3. Set Engine to TDC
- Note: Remove Rubber Cap (Inspection Plug)
As in Diagram to Right. Verify Marks
are Aligned

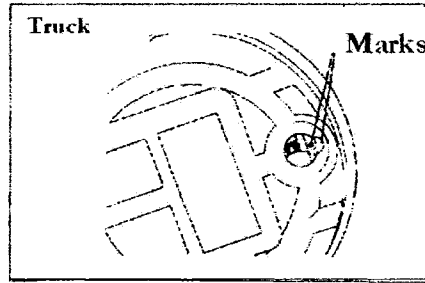

4. Turn Crankshaft (Right Direction)
Until Timing Alignment Mark and
No.1 Firing Position (Van) Use Mark
As In The Picture to the Right.

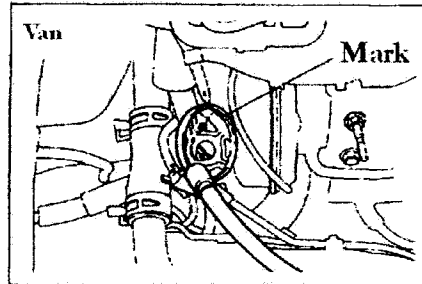

5. Use The Convenient Inspection Holes
in The Diagrams to the Right

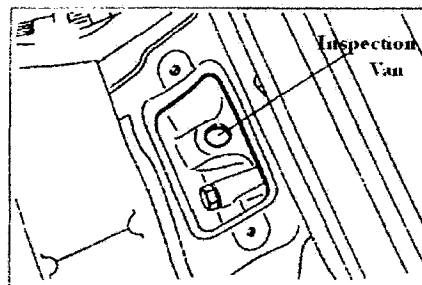
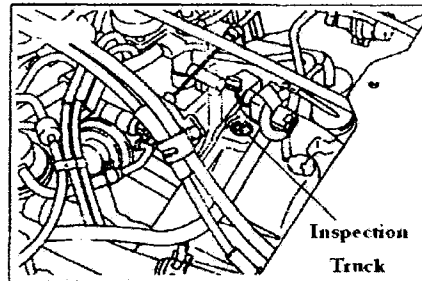

General Maintenance

Valve Adjustment

Note: Set Valves "Cold"

6. Using a Thickness Gage Set Valves Using The Following Diagrams

EF-NS - EF-TS (Cold Settings)

(IN)

0.18+/-0.05mm

(EX)

0.25+/-0.05mm

EF-ES (Cold)

(IN)

0.20+/-0.05mm

(EX)

0.30+/-0.05mm

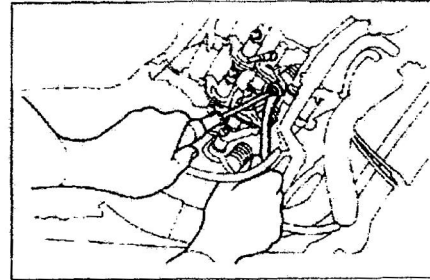

EF-NS-EF-TS Cylinder #1 TDC

Cylinder #1		Cylinder #2		Cylinder #3	
IN	EX	IN	EX	IN	EX
0	0	—	0	0	—

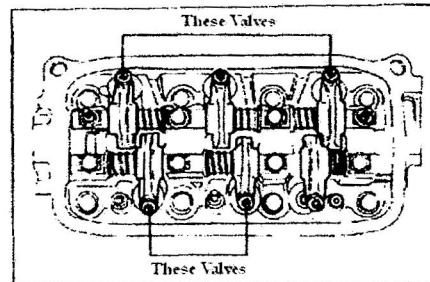

Rotate Engine one Revolution and set
Remaining Valves

Cylinder #1		Cylinder #2		Cylinder #3	
IN	EX	IN	EX	IN	EX
—	—	0	—	—	0

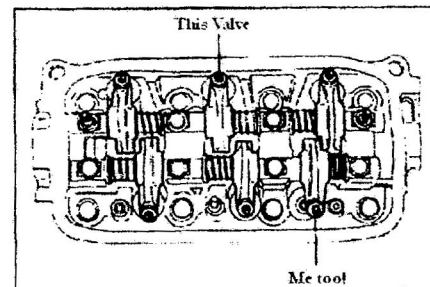

EF-ES Series

Cylinder #1		Cylinder #2		Cylinder #3	
IN	EX	IN	EX	IN	EX
0	0	—	0	0	—

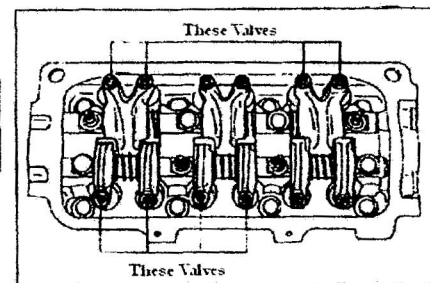

Chapter 3

Steering System

- **Steering Wheel Type & Components**
- **Steering Column & Components (MT Manual Vehicle)**
- **Steering Column Removal**
- **Tilt Steering Column Components**
- **Rack & Pinion Gearbox Removal**
- **Rack & Pinion Gearbox Overhaul**
- **Tie Rod Ends Removal and Installation**
- **Rack & Pinion Parts Diagram & Part Numbers**
- **Tie Rod & Center Arm Parts Diagram & Part Numbers**

**Note: Front End Alignment Specifications Included
In Suspension Chapter**

Steering System

Steering Wheel

T: =kg.cm

Type 1

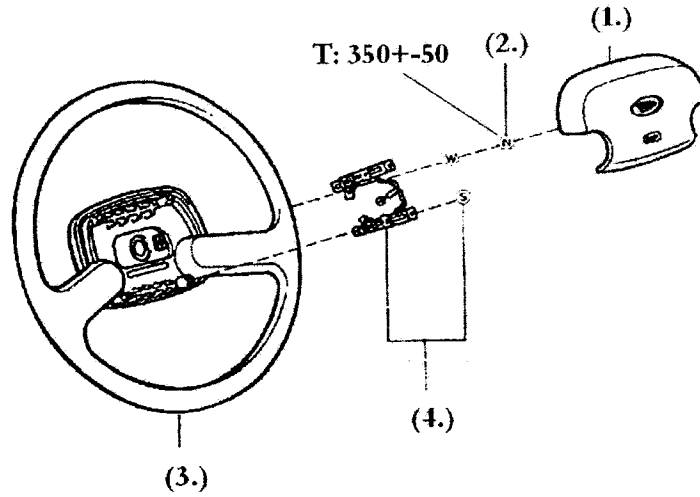

- 1. Steering Wheel Pad
- 2. Lock Nut
- 3. Wheel: Steering
- 4. Horn Contacts

Type 2

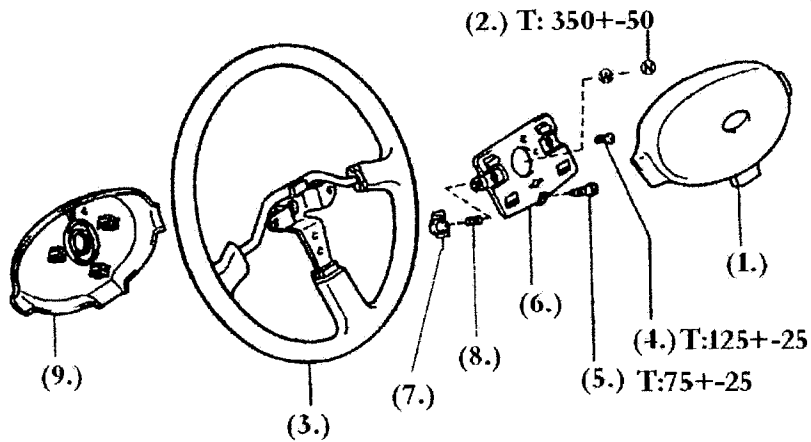

- 1. Steering Wheel Pad
- 2. Lock Nut
- 3. Wheel
- 4. Screw: Round Taping
- 5. Screw: Cross Recess Round
- 6. Plate: Horn Button Contact
- 7. Cushion: Horn Button
- 8. Spring: Horn Button
- 9. Cover

Steering System

Steering Column Components

Manual Steering MT Vehicle

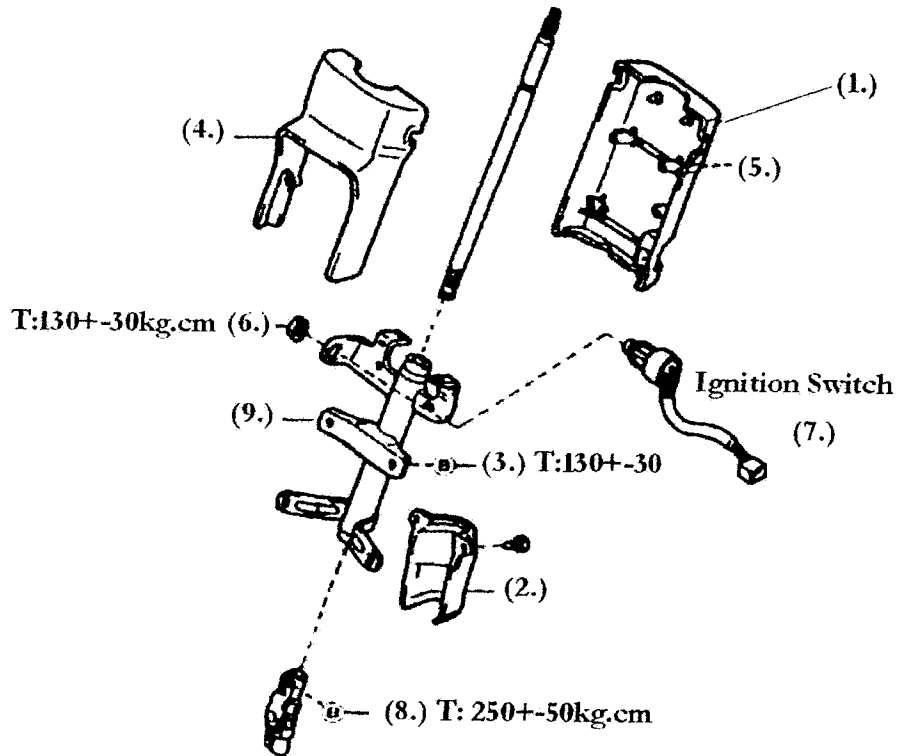

1. Cover: Steering Column
2. Cover: Main Shaft Joint
3. Bolt: Column Attachment
4. Cover: Steering Column Upper
5. Bolt: Attachemnt
6. Nut: Ingnition Cylinder
7. Ignition Switch
8. Bolt: Steering Shaft U-Joint
9. Column Body

Note: (B)=Bolt (N)=Nut

Steering System

Steering Column Removal

Note: Disconnect (-) negative Battery Terminal

1. Remove Steering Column Lower Cover

2. Remove Main Shaft Joint Cover

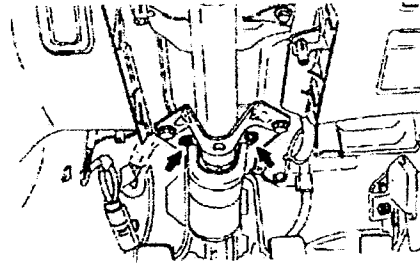

3. Remove Column Assembly (Body) Bolts

4. Remove Steering Column Upper Cover

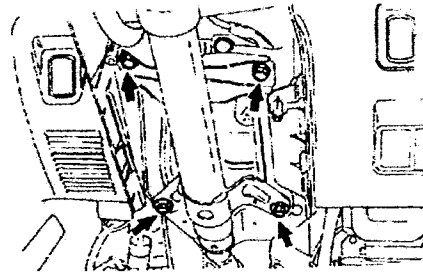

5. Remove Combination Switch Attachment Bolts (See Right Diagram)

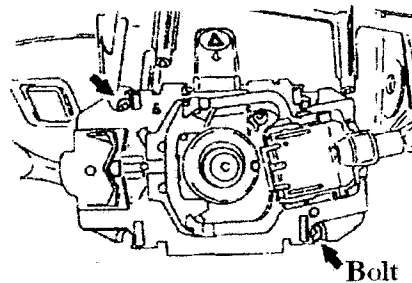

6. Remove Ignition Switch Retainer Nut

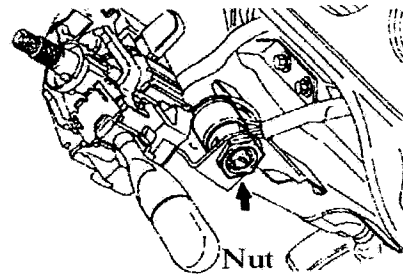

7. Disconnect Combination Switch Harness (Two Connectors) See Diagram on Right

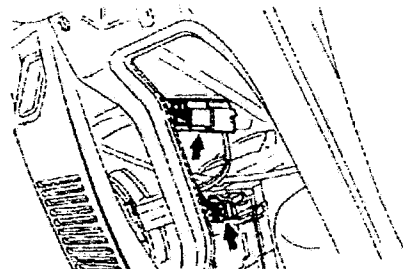

Connectors

Steering System

8. Remove U-Joint Attachemnt Bolt. Remove Steering Column.

Note: Inspect U-Joint, any Cracks Detected Unit Must be Replaced

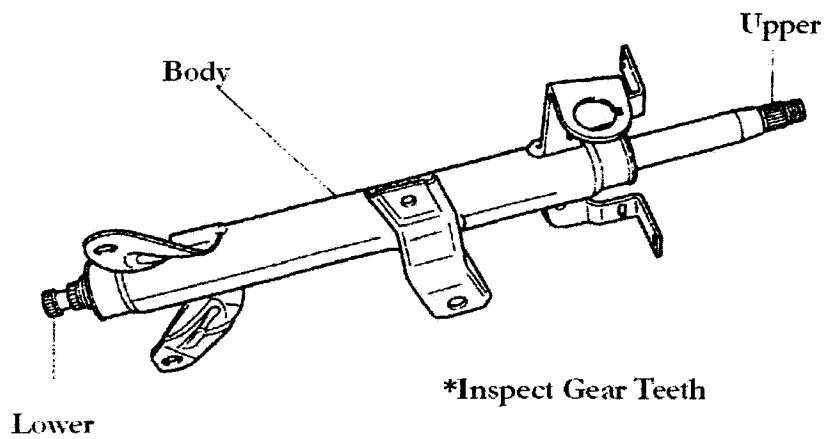
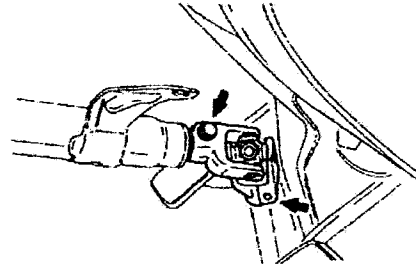

Note: When Installing U-Joint Make Sure Front Wheels are Facing Forward

U-Joint Torque: 250+-50kg.cm

Caution: Do Not Over-Torque U-Joint, U-Joint Will Be Damaged and Can Fail

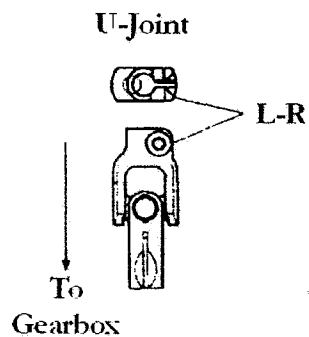
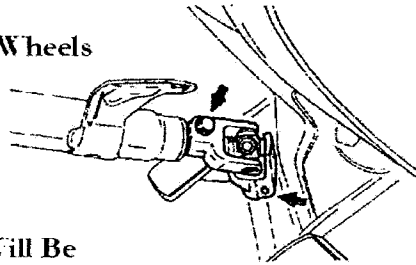

Steering System

Tilt Steering Column Components

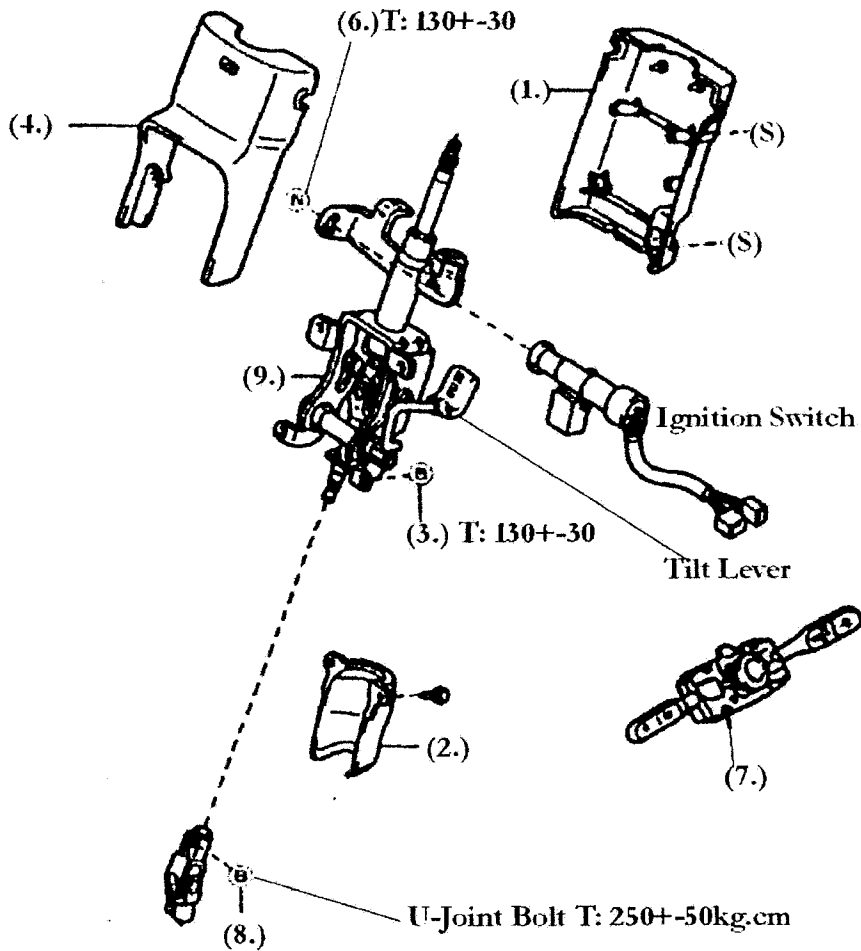

- 1. Cover: Steering Column Lower
- 2. Cover: Main Shaft U-Joint
- 3. Bolt
- 4. Cover: Steering Column Upper
- 5. Attachment Screws

- 6. Ignition Switch Retainer Nut
- 7. Combination Switch
- 8. Bolt: U-Joint Use
- 9. Column Assembly

Steering System

Manual Steering Gearbox (Rack & Pinion) Removal

(B)=Bolt
(N)=Nut
(S)=Screw

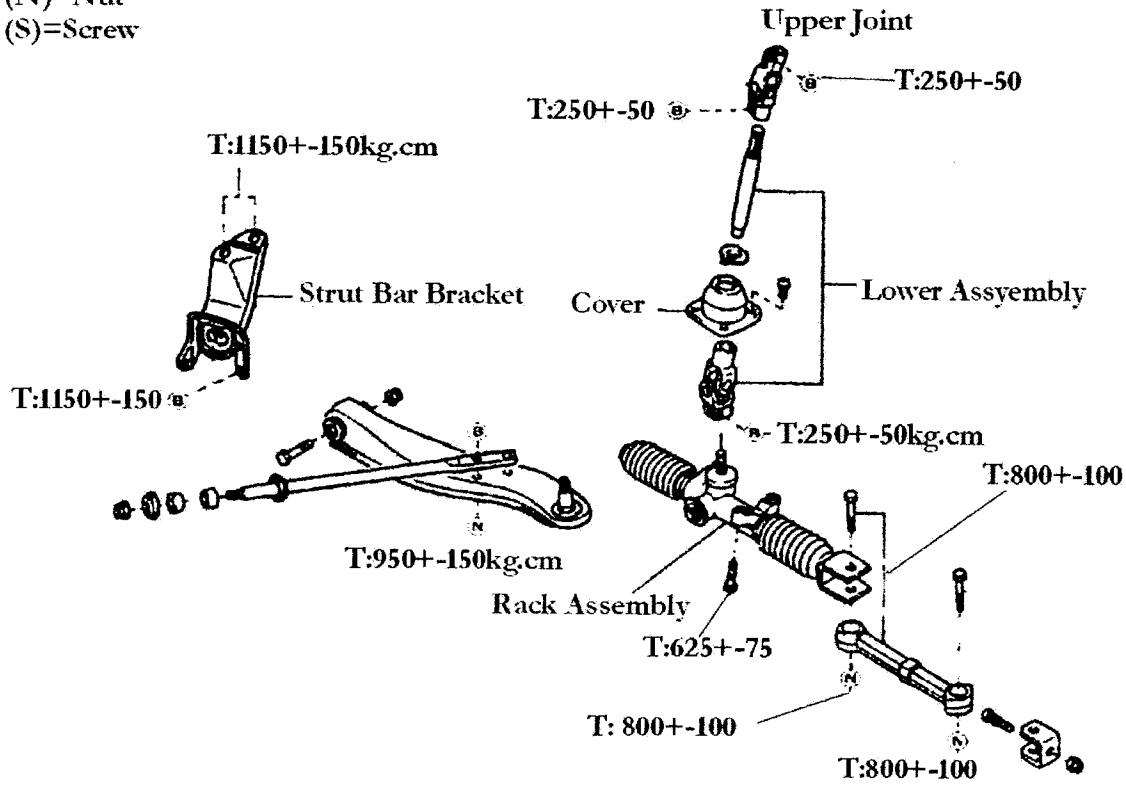

Removal

Preparation Note: Remove (RH) Tire

1. Remove Lower Dust Cover

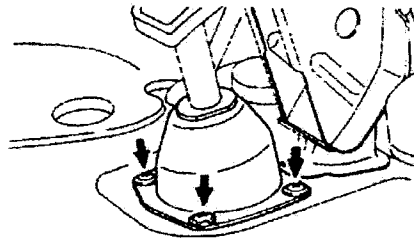

Steering System

Rack & Pinion Removal

2. Remove Main Shaft U-Joint Cover

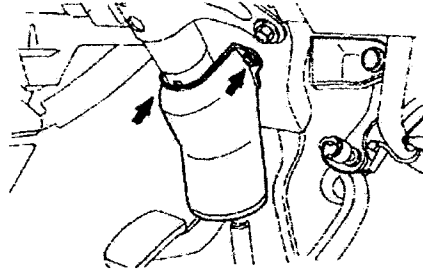

Note: Make Sure Wheels are Pointed Straight

3. Remove Bolts in Diagram to Right

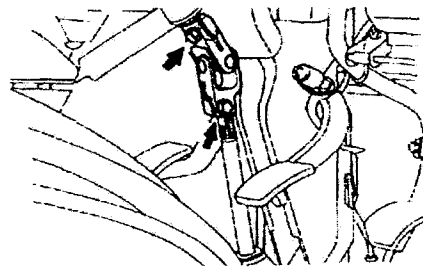

4. Remove Steering Drag Link Attachment Bolt

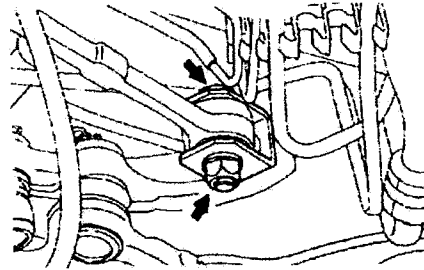

Caution: Bolt is Lifted Upwards, Pay Attention Not to Damage Hoses and Lines

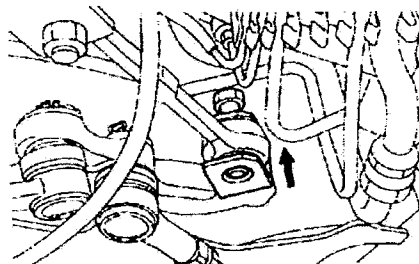

5. (MT Vehicles) Remove Clamp Holding Clutch Cable and Move to Side

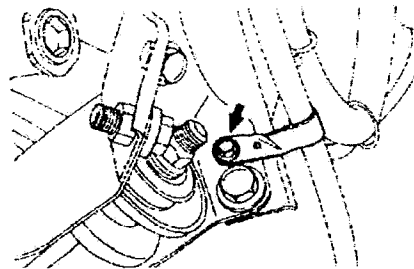

Steering System

Rack & Pinion Removal

6. Remove Speedometer Cable Retaining Clamp
(See Diagram on Right)

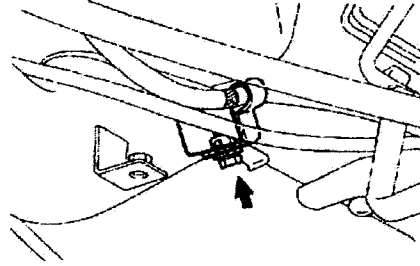

7. Remove the Bolts & Nuts Retaining (RH) Strut
Bracket as Indicated in the Diagrams to the
Right

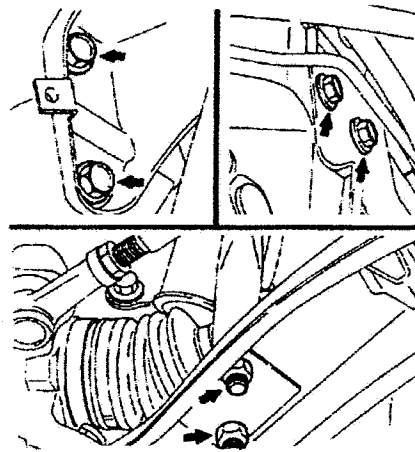

8. Remove Assembly Attachment Bolts
Slightly Lower Unit

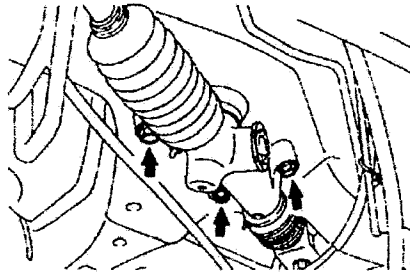

9. Disconnect Universal Joint Attachment Bolt

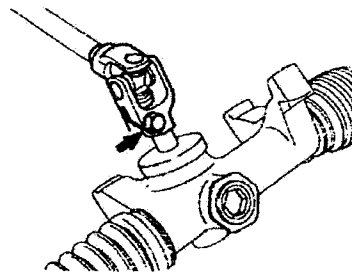

Steering System

Rack & Pinion Removal

10. Remove Steering Drag Link Retaining Bolt

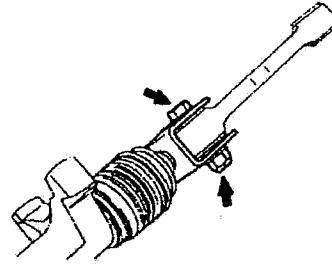

11. Remove Assembly

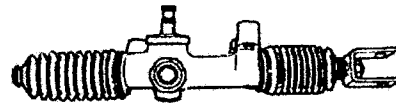

Note: See Next Section for Overhaul

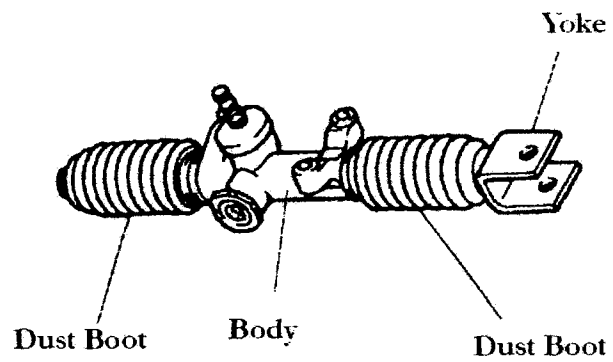

Steering System

Rack & Pinion Overhaul

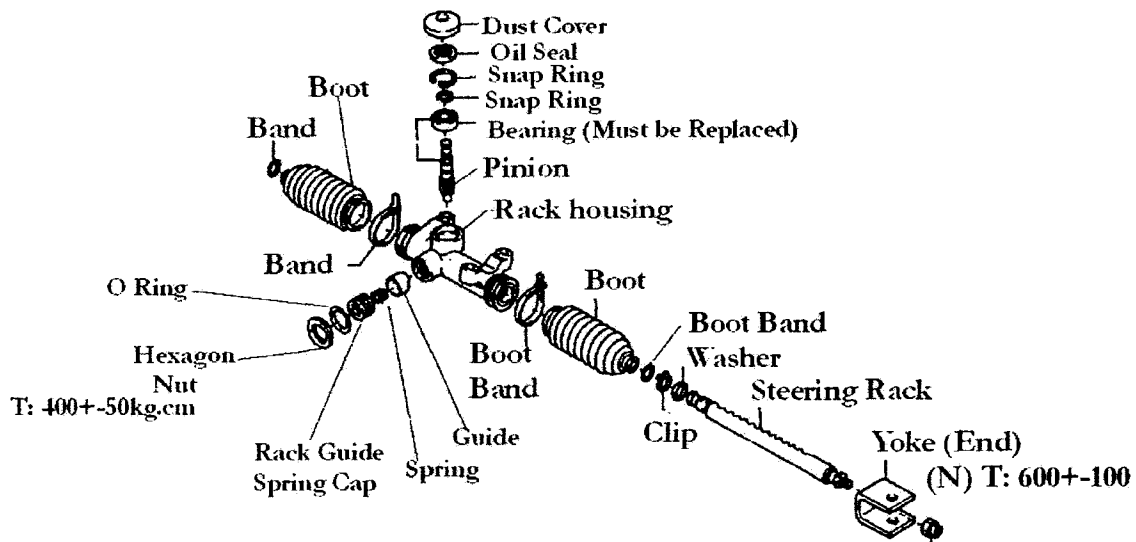

Disassembly

Note: Use Service Tool Vise Holder Adapter 09612-00012-000

Note: Bolt Rack Assembly To Vise Adapter as Shown. Do Not Place Rack Directly in Vise

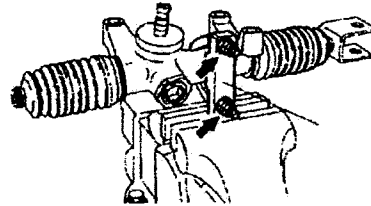

1. Remove Rack Yoke (End) Retaining Bolt
Remove Yoke

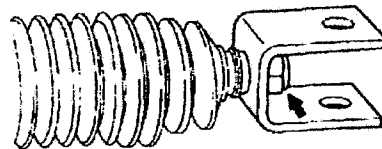

Steering System

Rack Disassembly

2. Remove the Following Parts (See Right Diagram)
(RH-LH) Boot Bands
(RH-LH) Boots
Dust Cover

Note: All Parts Must be Discarded & Replaced

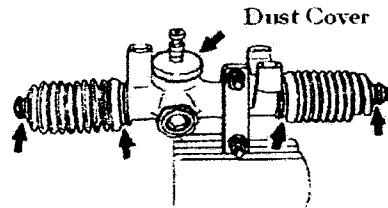

- Note: Use Service Tool #09922-10010-000
Note: Mark Nut With Present Alignment Position
3. After Marking an Alignment Mark Remove Nut
With Service Tool or Available Tool

Note: If Nut is Damaged (Rounded) Replace

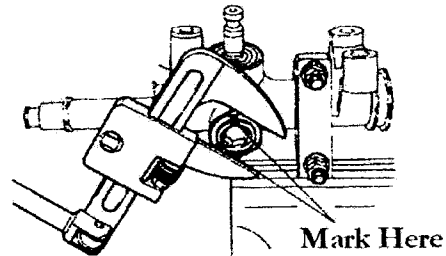

4. Use a Rack Guide Remover Tool (Shown Below)
and a Combination Wrench to Remove Guide

Note: Use Proper Tools or Damage Can Occur

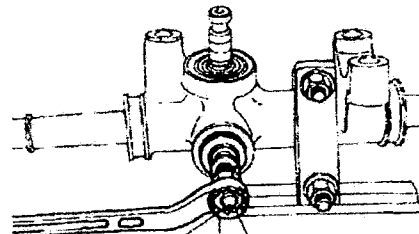

How to Make Tool

Take a 17mm Bolt & Two(2) 17mm Nuts. Screw Nuts Down Over Shaft and Tighten. Use a Box Wrench and Back Out Guide

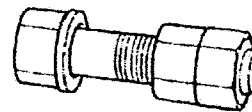

17mm Nuts

Note: Not Necessary to Over Tighten. Snug is Fine (Finger Tight Enough)

Steering System

Rack Disassembly

5. Remove Rack Guide Cap O Ring, Clean and Install New O Ring

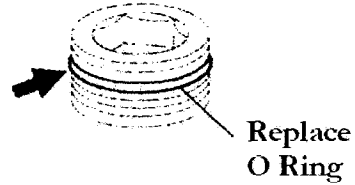

6. Remove Compression Spring & Rack Guide
Inspect for Cracks in Guide, Replace if Found Worn

7. Use a Flate Head Driver (-) and Pop Out Oil Seal
Note: Oil Seal is (Type K)

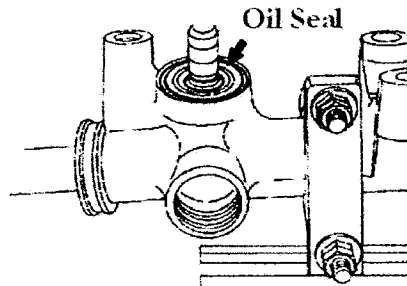

8. Remove Snap Ring
(Replace)

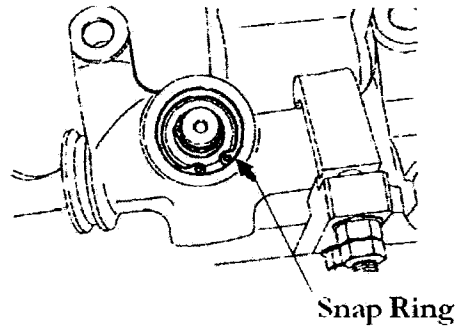

Note: Use Service Tool #09631-87201-000 To Remove Pinion

9. Use Puller to Remove Pinion & Bearing From Housing

Note: Bearing Con Not Be Re-Used

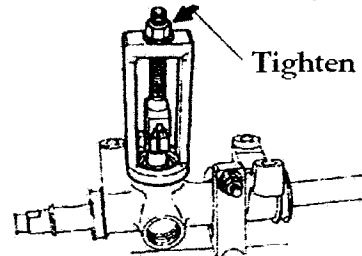

10. Remove Snap Ring From Pinion Shaft

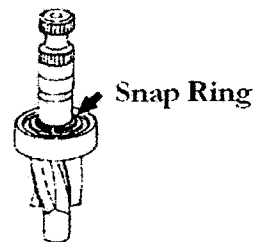

Steering System

11. Use a Press & Remove Bearing From Pinion Shaft

Note: Discard Bearing

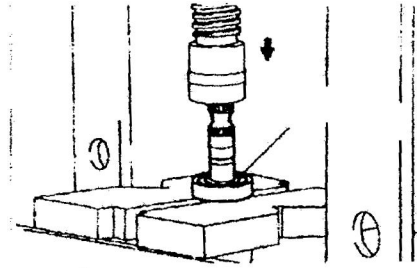

12. Remove Snap Ring From Rack and Slide Rack Out From Housing

Disassembly Complete

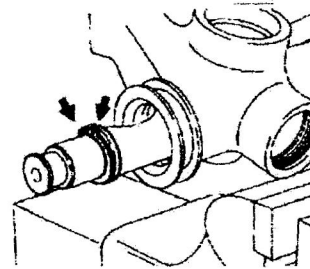

Assembly

Note: Clean Housing Body Thoroughly Before Assembly

Housing Preparation

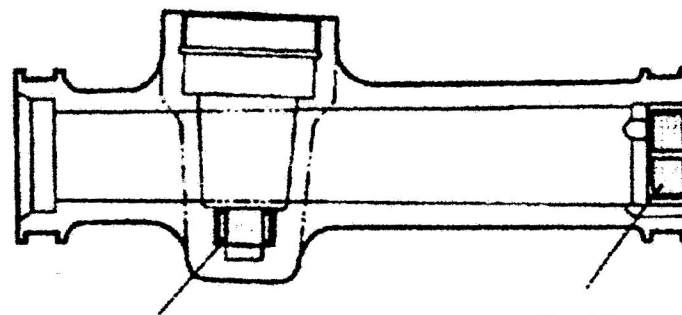

Needle Bearing Grease
1.0+/-0.2Gram Grease

Bushing
1.0+/-0.2Gram Grease

Grease: Long Life Chassis Grease

Steering System

Rack Assembly

Note: Before Assembly Rack Must be Greased at Points Marked in the Diagram

Grease: Long Life Axle/Chassis Grease

Grease Points (Rack)



1. Slide Rack into Housing, Attach Back-Washer and New Snap Ring

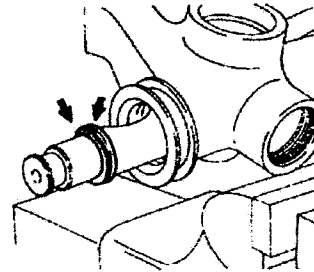

2. Using a Press, Press on New Bearing

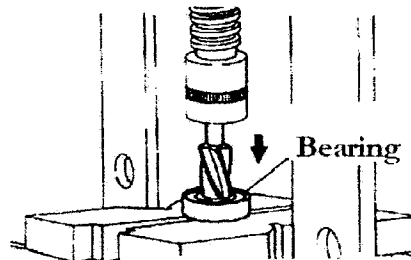

3. Attach New Snap Ring

4. Use a Hard Plastic Hammer to Install Pinion into Housing Assembly.

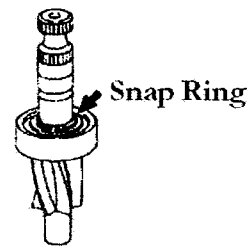

Note: Coat Bearing With Grease Before Installation

Steering System

Rack Assembly

5. Install New Retainer Snap Ring

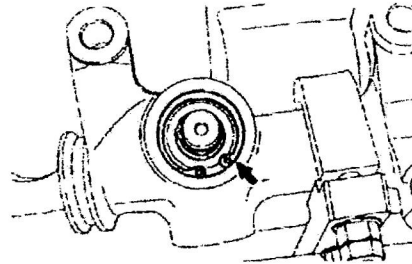

6. Install New Oil Seal

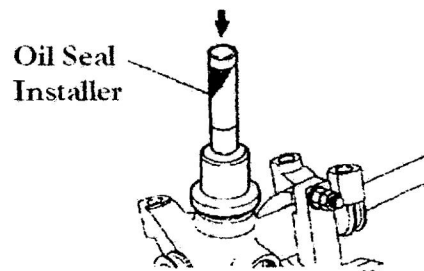

Caution: Oil Seal Lip Must Be Covered With Minimum of 0.3+0.1g of Long Life Chassis Grease

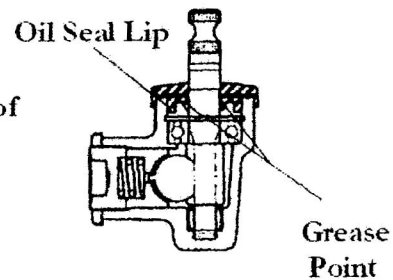

7. Install New O Ring on Guide Spring Cap

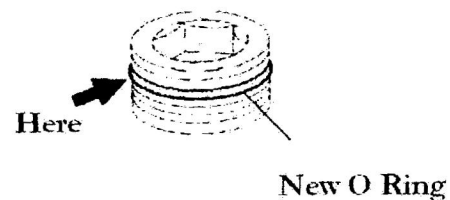

8. Assemble Rack Guide and Compression Spring

Note: Coat Parts in Long Life Chassis Grease
Minimum: 6~8g

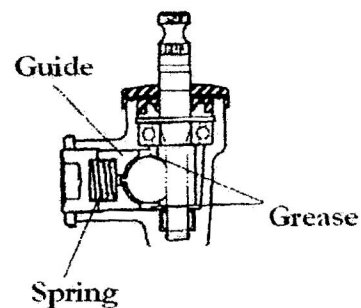

Steering System

Rack Assembly

9. Tighten Cap to 70kg.cm

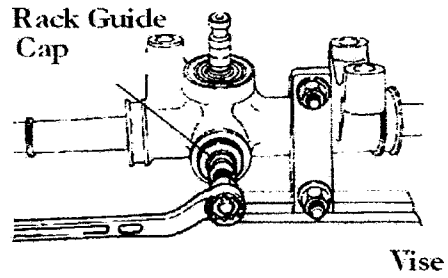

10. Line Up Hexagon Nut With Alignment Mark and Set Torque T:400+/-50kg.cm

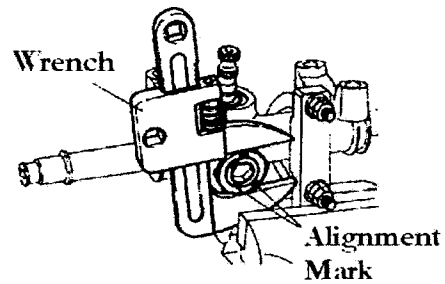

11. Set Torque T: 12~14kg.cm

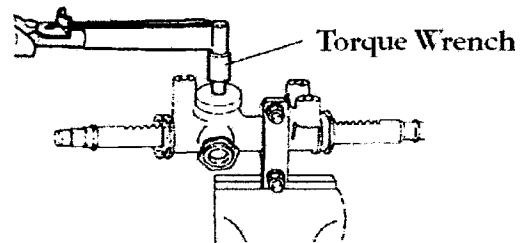

12. Install New Dust Cover and Coat With Grease

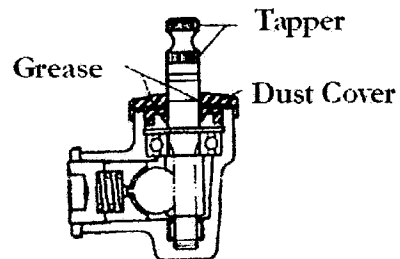

13. Install New Boots and New Attachment Bands

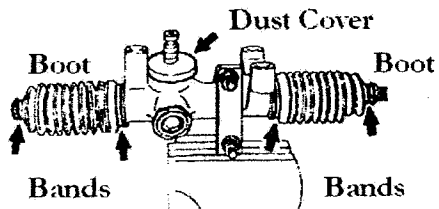

14. Attach End Yoke and Torque T: 600+/-100kg.cm
15. Install in Vehicle

Steering System

Tie Rod Ends

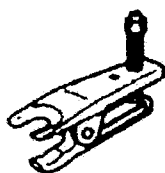

Service Tool #09611-87701-000
Tie Rod End Puller

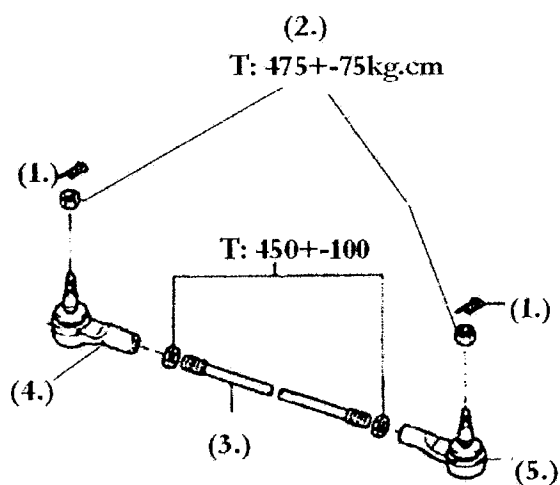
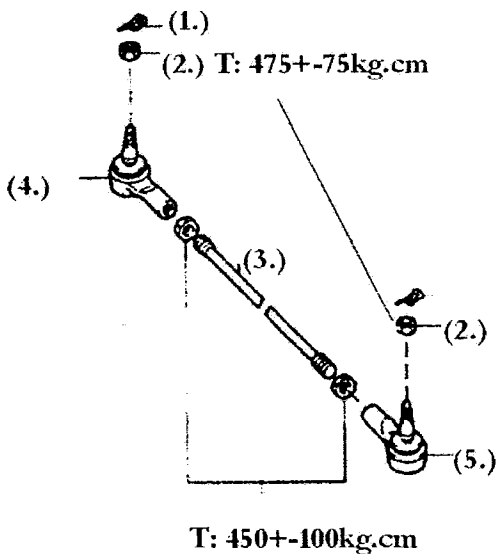

1. Cotter Pin
2. Castle Nut
3. Tie Rod
4. End: Tie Rod No. 1
5. End: Tie Rod No.2

Part Numbers See Parts Page

Tie Rod Removal & Replacement

Note: Replacing Front End Components
Requires Front End Alignment

1. Jack Vehicle and Remove Front Tires
2. Remove Cotter Pin (Discard) and Castel Nuts

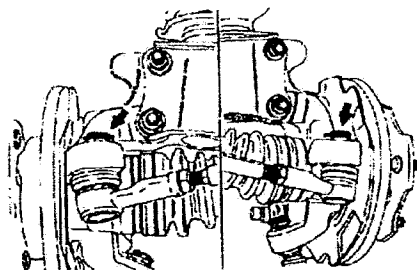

Steering System

Tie Rod Removal

3. If The Tie Rod is Removed For Maintenance and not Replacement Remove Castle Nut & Use Dummy Nut and Puller to Push Out End

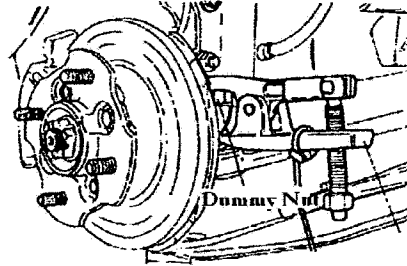

4. Press Out End(s)

5. Center Arm End Removal: Remove Cotter Pin and Castle Nut

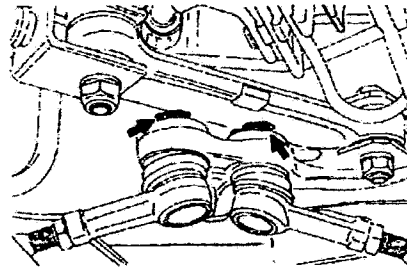

6. Slide in Remover Tool and Press Out. Remove Entire Tie Rod Assembly

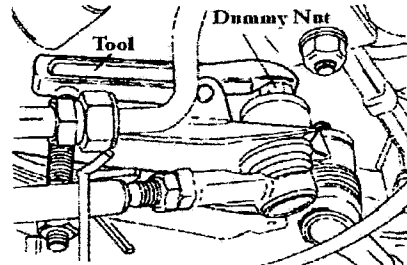

7. If End is to be Replaced Make Alignment Mark as in Diagram to the Right. Back Off Lock Nut and Unscrew End. Replace and Do Not Tighten Lock Nut. Lock Nut Shall be Torqued After Alignment Has Been Completed

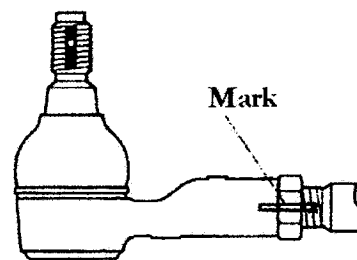

8. Install New Tire Rods and Attach to Vehicle, Adjust Alignment

Note: Make Sure Tire Size and Tire Pressure Are Correct Before Alignment

Steering System

Rack & Pinion Parts

Manual Steering

(N)=Nut
(B)=Bolt

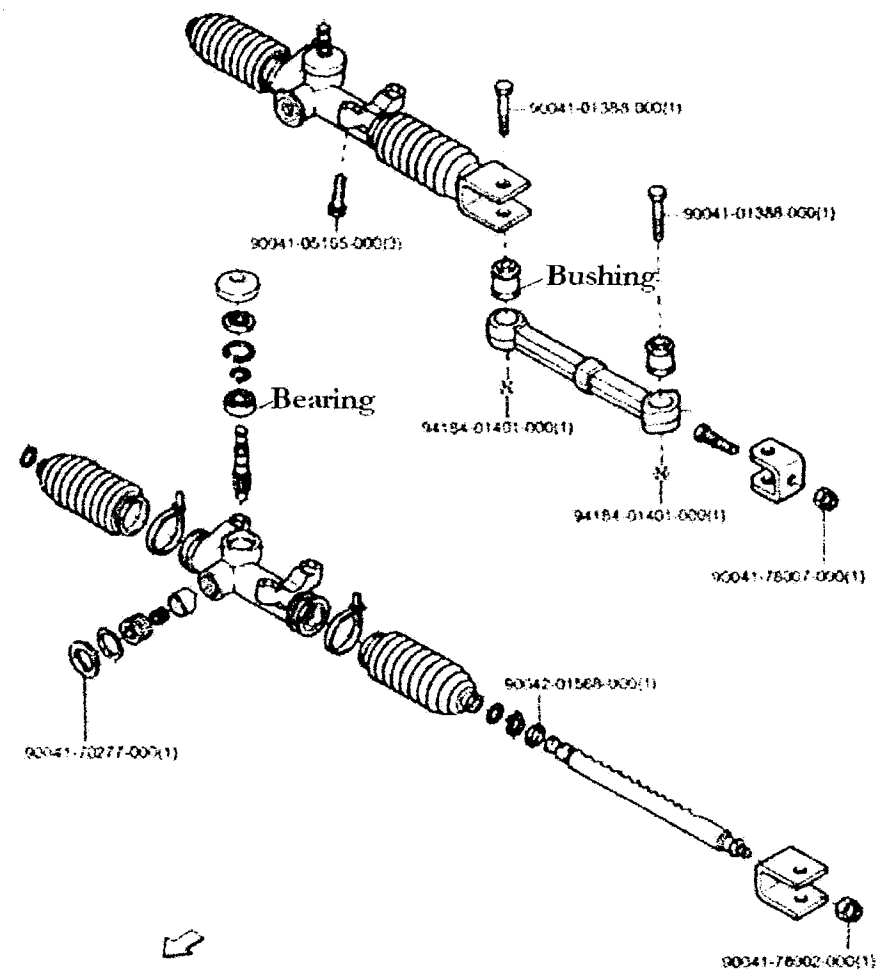

Note: Rack Unit Has Limited Parts Availability

Boots

S100, 110, 120, 130, 140 (MT, DX, LX, NGD, 2S+S100VSMRS) #45535-87509-000

S120, 130 DOHC +120 VZMQT, 0VFMQT, S130VZMRS #45535-87507-000

S100, 110 (DECK VAN-OLD) # 45535-87507-000

S120, 130 DOHC # 45535-87508-000

Bearing

(ALL) # 90043-63147-000

Bushing

(All) #90043-85163-000

Note: Above Listed Parts Still Available at Time This Book Is Published

Steering System

Tie Rod End Parts

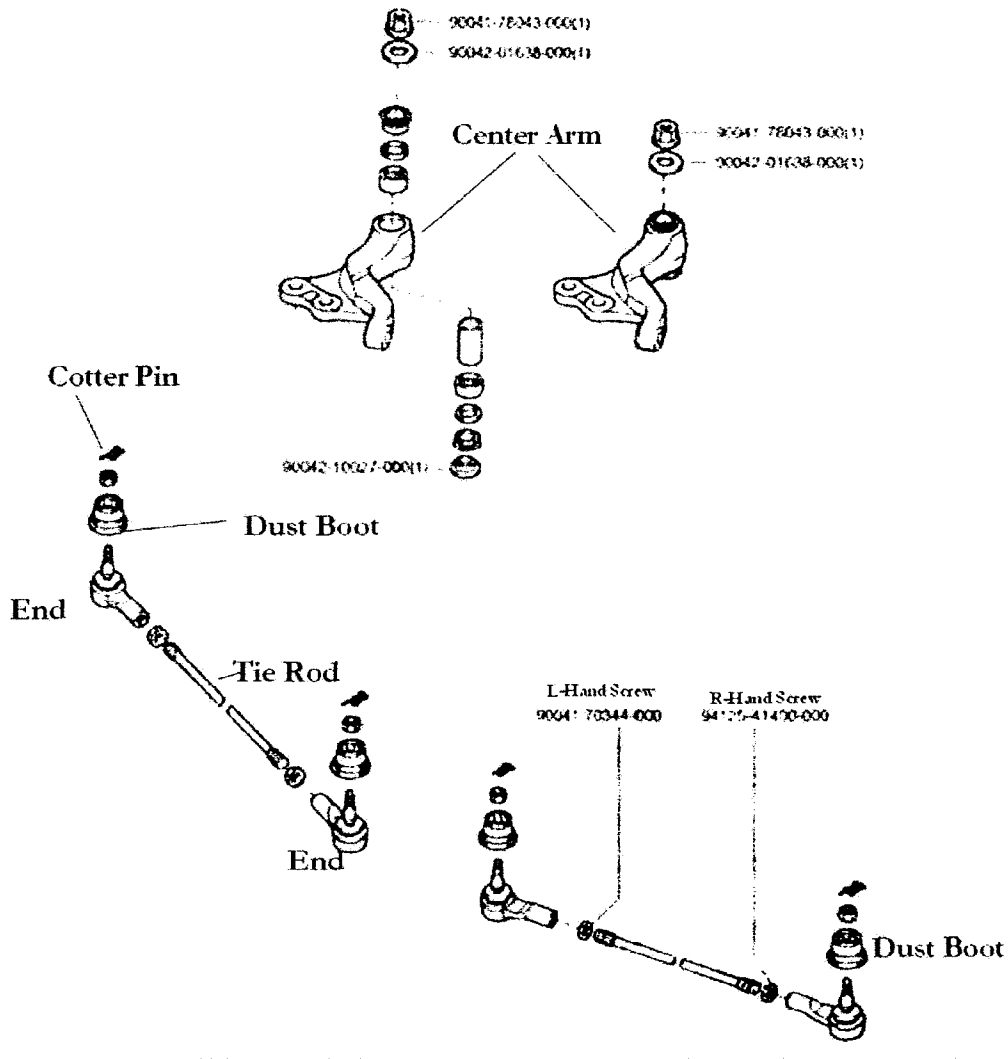

Parts & Part Numbers Note: Some Parts May or May Not Be Available On Older Models

Tie Rod End (Right) (All) #45047-87583-000

Tie Rod End (Left) (All) #45046-87583-000

Steering Center Arm

EV, PS1, PS2, PS3 #45402-78536-000

DOHC, CRM, PF2 #45402-87540-000

EFI, TR,MT,DX,MX (HX., NTBO) #45402-87539-000

Tie Rod End Dust Boot

(ALL Ends) #45479-87508-000

Chapter 4

Suspension

- **Tire Size & Air Pressure**
- **Alignment**
- **Strut Components**
- **Front Strut Removal & Replacement**
- **Rear Shock Absorber Replacement**
- **Rear Leaf Spring Components**
- **Rear Coil Spring Suspension (Van)**
- **Rear Coil Spring & Differential Removal**
- **Rear Lateral Control Rod Diagram**
- **Front Strut & Parts**
- **Rear Leaf Spring Suspension Parts**
- **Front Suspension Parts**

Suspension

Tire Size & Air Pressure (kg.cm)

Check tire pressure at regular intervals

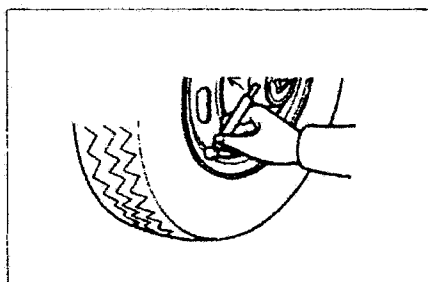

Tire Pressure Guide

Vehicle Series		Size	Air (kg.cm)	
			F	R
S100P, S110P S100C, S110C S100CT, S110CT		5.00-12-4	2.0	2.4
		5.00-12-6		
		145R12		
S100V	AT	5.00-12-4	2.2	2.4
	MT	5.00-12-6	2.4	2.4
	All	145R12	2.4	2.6
S110V		5.00-12-4	2.4	2.4
		5.00-12-6	2.4	2.4
		145R12	2.4	2.6
S120V		145R12	2.4	2.4
		155R12	2.2	2.2
		165/70R13	2.4	2.4
S130V	ZMGE, ZHGE	145R12	2.4	2.4
	FMQE		2.6	2.6
	ZMGE, ZHGE, ZMGT	155R12	2.2	2.2
	FMQE		2.4	2.4
	All		165/70R13	2.4
T125/90 D12			4.2	

Tread

Check uneven tread wear and cracks in the sidewall. Replace if necessary

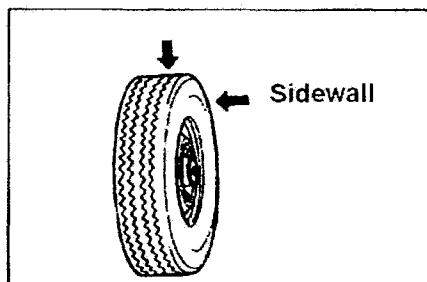

Suspension

Alignment

Note: Make Sure Tire Size and Air Pressure
Are Correct Before Alignment

1. Loosen Tie Rod End Lock Nut

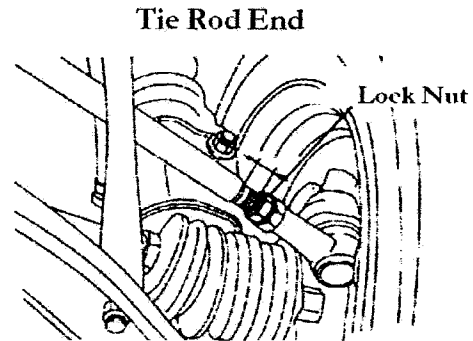

2. Measure Toe In

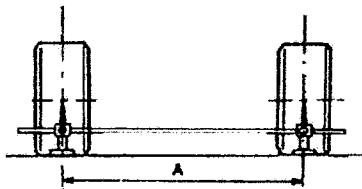

Specifications: (All) 0.0+-1.0mm

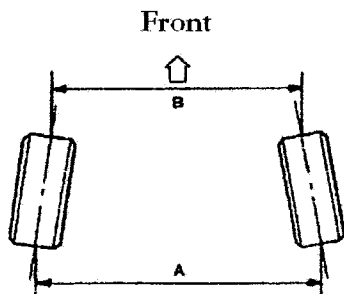

3. Set Toe In to Specifications
4. Torque Tie Rod End Lock Nut to T: 450+-100kg.cm

Note: After Setting Torque Once More Verify Toe In

5. Set Camber & Caster

Suspension

Camber & Caster

Note: Use an Camber & Caster Gage to Set Specifications

Camber Specification: $0^{\circ}15' + -45'$

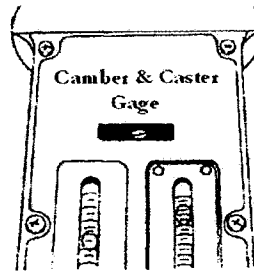

Camber & Caster

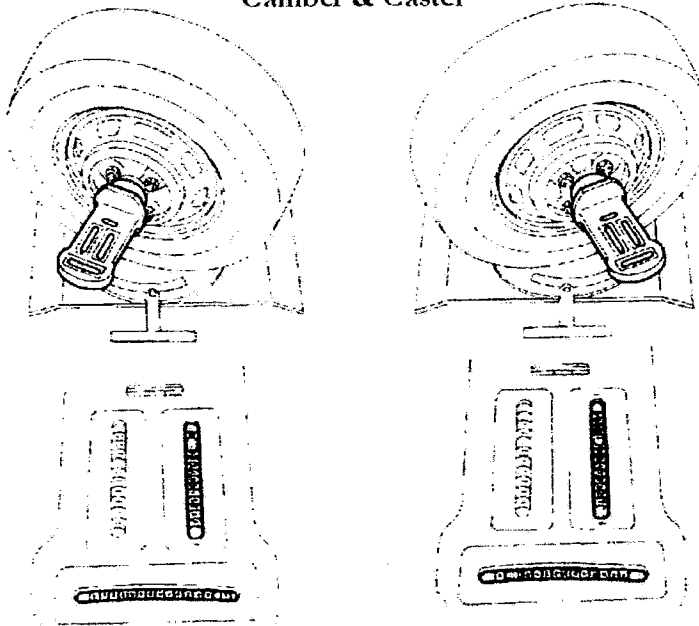

Specifications

Caster:
 $3^{\circ}08' + -1$ (Truck)
 $3^{\circ}04' + -1$ (Van)
King Pin Degree $13^{\circ}03' + -1$

Front Side Slip= In 5mm~Out 5mm

Note: (*)=Degree

Suspension

Strut Components

Torque: (kg.cm)

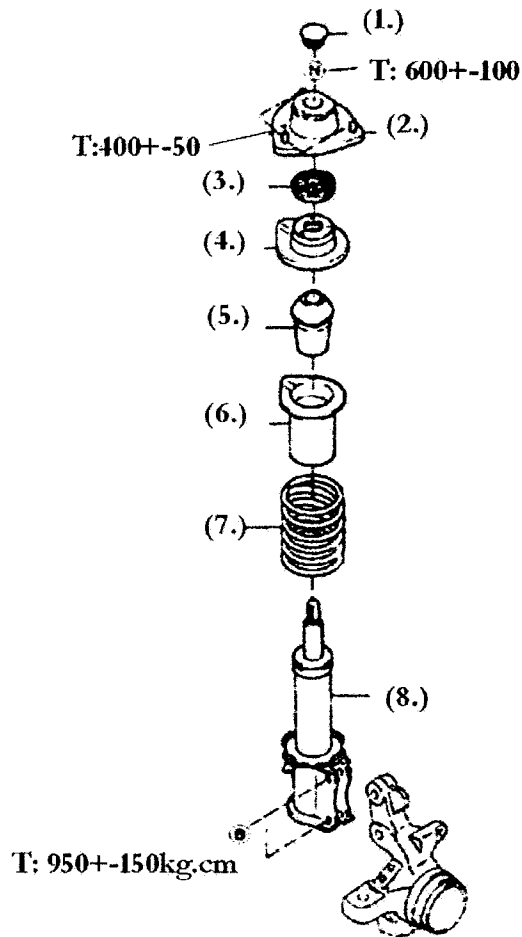

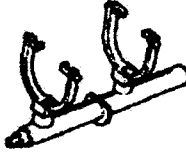
Components	Tool
1. Cover: Steering Dust	Coil Spring Compressor
2. Support S/A: Front Suspension	
3. Bushing	
4. Seat Ay: Front Spring Upper	
5. Bumper: Front Spring	
6. Cover: Strut Dust	
7. Spring: Coil Front	
8. Front Strut Assembly	
	P/N#09727-30020-000

Suspension

Front Strut Removal

1. Jack Vehicle & Remove Front Tires
2. Remove Brack Hose Clamp
3. Remove Strut Lower (2) Attachment Bots

Note: Lower Attachment Bolts Must be Replaced

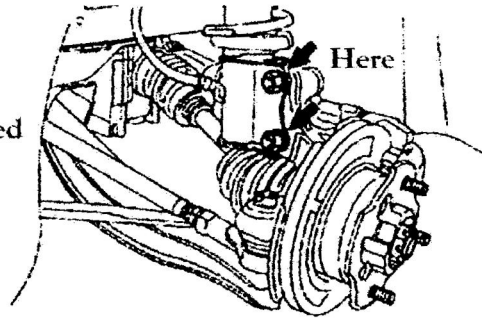

4. Remove Upper (3) Attachment Nuts as Seen in Right Side Diagram. Remove Strut Assembly With Coil Attached

Note: Retainer (3) Nuts Must be Replaced

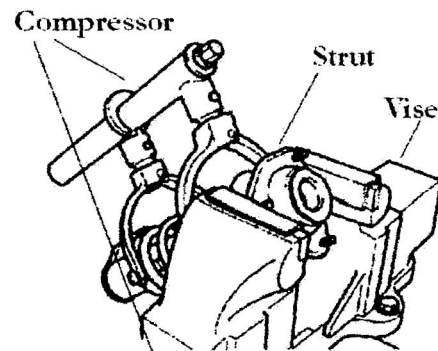
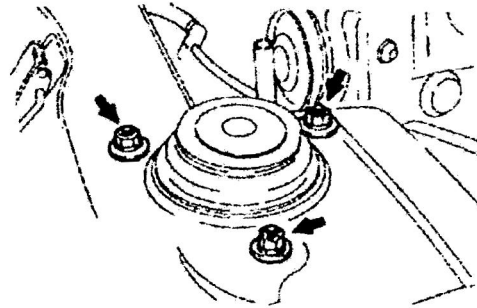

5. Use Spring Compressor Tool and Compress Spring
6. While Spring is Compressed Remove Support and Slide Off Spring.

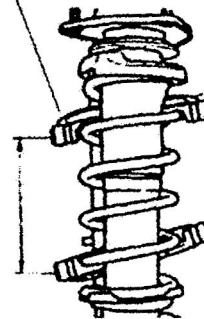

Bottom View of Compressor

Suspension

Strut Installation

Note: Strut Can Not Be Rebuilt, If Defective or Damaged Must be Replace

Note: Inspect Strut for Free Travel and or Oil Leak

Note: If Strut is Over 60,000 Kilometers Replace



Installation

1. Compress Spring with Spring Compressor
2. Place Spring Onto Strut and Position as in Diagram on Right

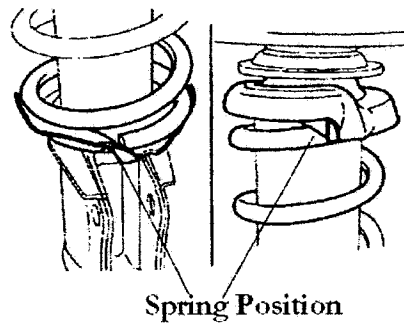

3. Coat Upper Bushing With Long Life Chassis Grease
Minimum Grease: 0.5g

4. Attach Front Suspension Support (Item (2.) Diagram)
5. Remove Spring Compressor
6. Install Strut Assembly Into Vehicle in Reverse Order

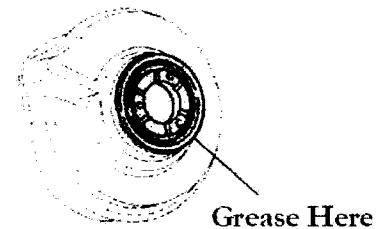

Note: Only New Nuts & Bolts Must be Used For Assembly

Torque

Top Nut T: 600+-100kg.cm

Support (2.) T: 400+-50kg.cm

Lower Strut Mount T: 950+-150kg.cm

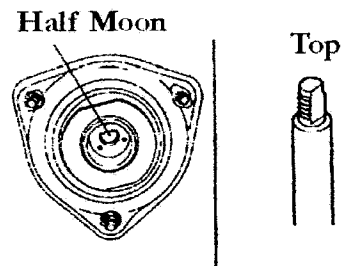

Strut Travel Range

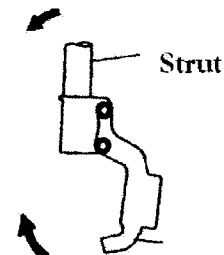

Suspension

Rear Shock Absorber

(N)=Nut
(B)=Bolt
(T)=Torque

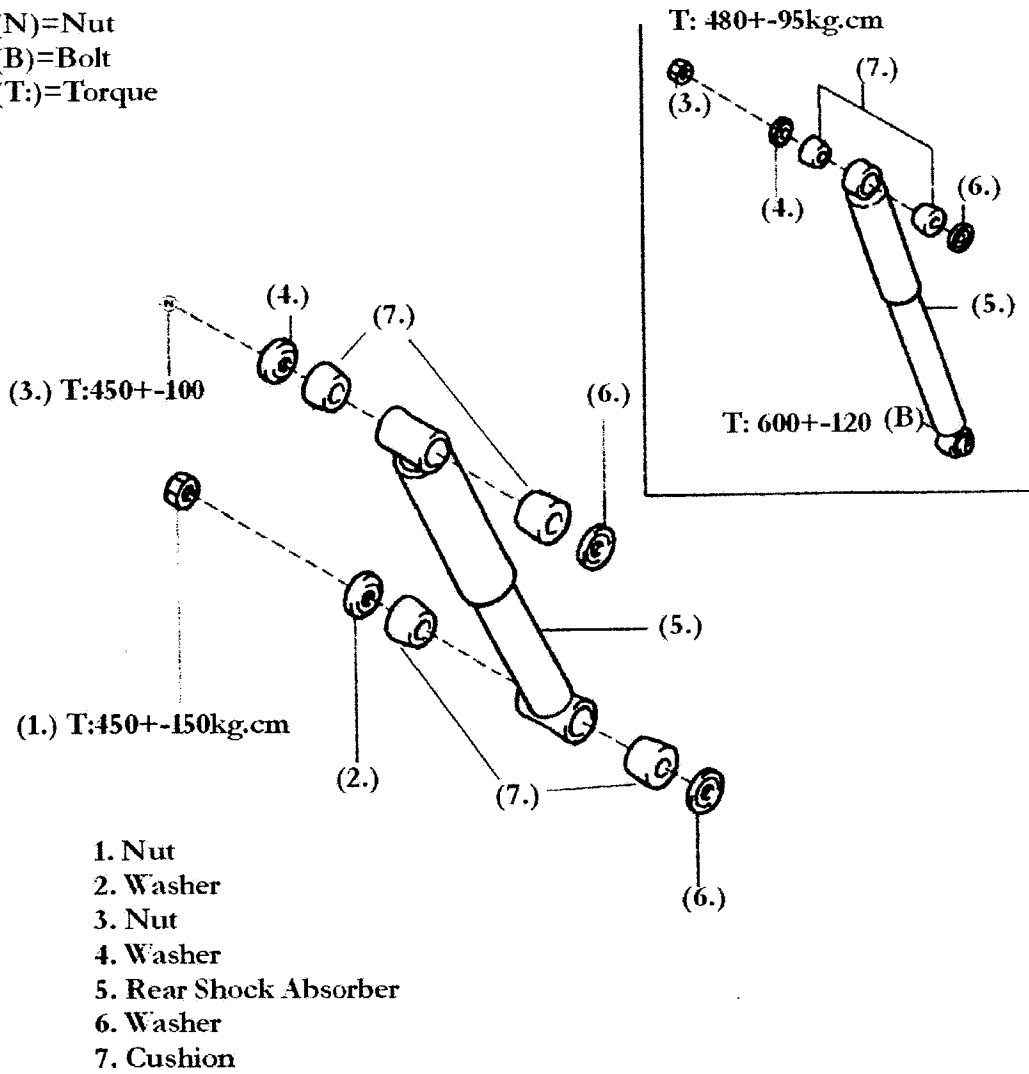

Replacement

1. Jack up Rear of Vehicle and in Diagram on Right
2. Remove Rear Wheels
3. Remove Spare Tire (AC Equipped)

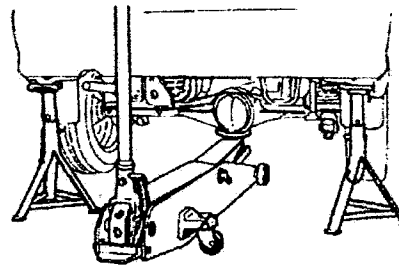

Suspension

Rear Shock Removal

AC Equipped Only

1. Remove AC Hose Bracket

Caution: Do Not Scratch Hose or Oil Will leak.

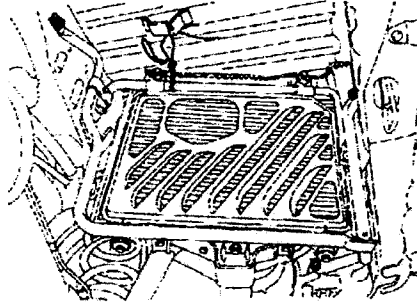
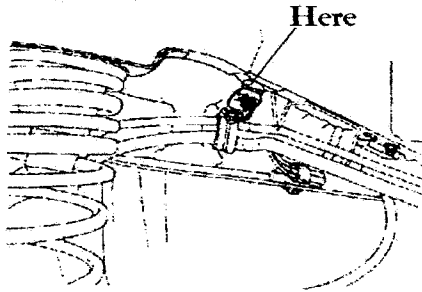

2. Remove (4) Condenser Bolts & Lower Unit

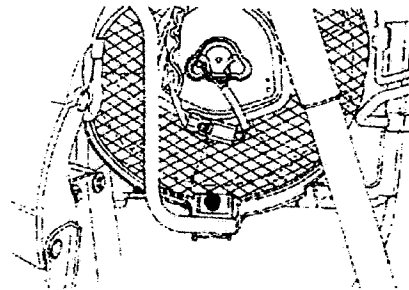

4. Remove Lower Attachment Nut

Note: Nuts Must Be Replaced

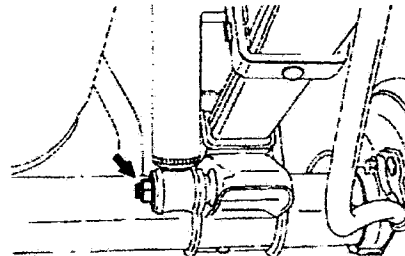

5. Remove Upper Attachment Nut

6. Remove Shock and Replace New Unit

7. Installation is Reverse Order

Note: All Torque Specifications on Previous Page



Suspension

Rear Leaf Spring

(N)=Nut
(W)=Washer
(B)=Bolt

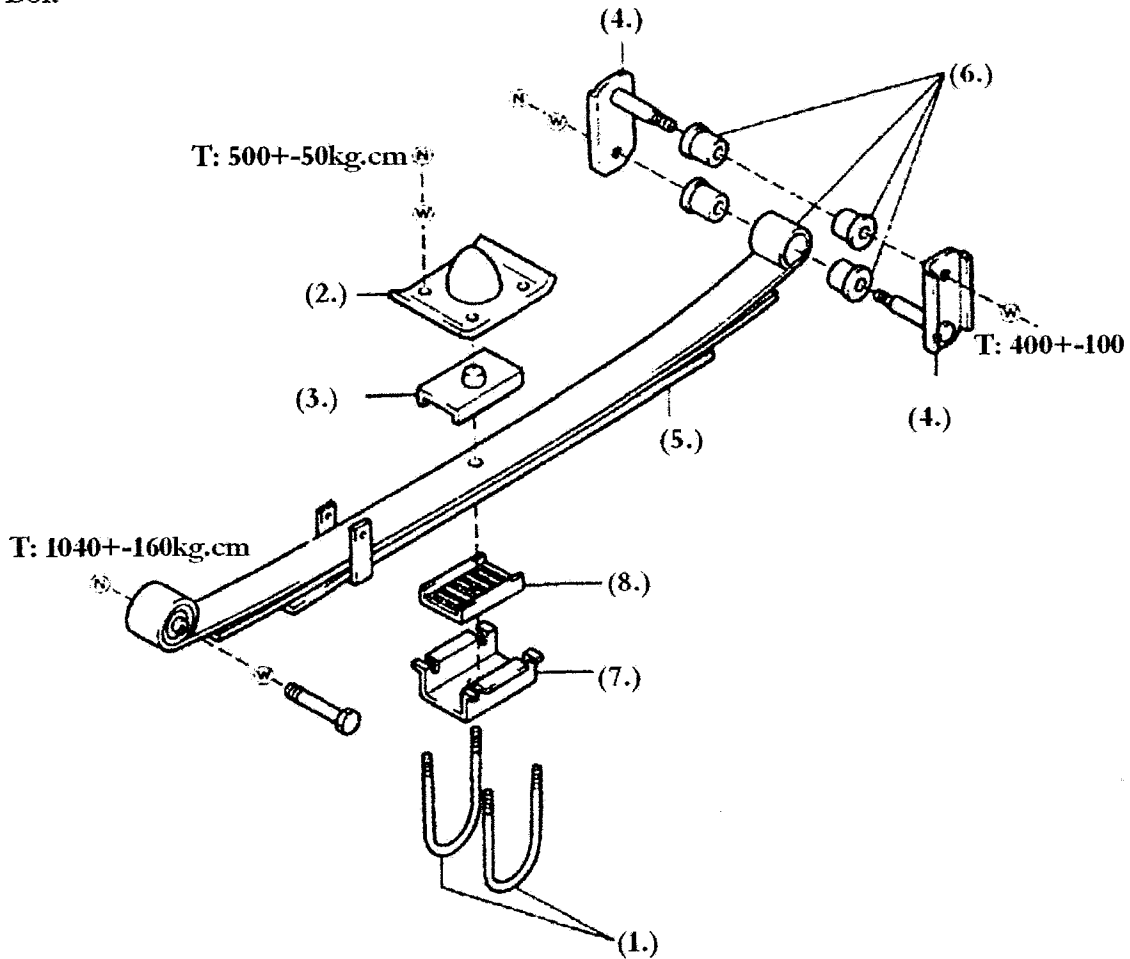

1. U-Bolt
2. Bumper: Rear Spring
3. Pad: Spring Upper
4. Shackle S/A: Rear Spring
5. Leaf Spring
6. Bushings
7. Retainer: Spring Pad
8. Lower Spring Pad

Suspension

Rear Coil Spring Suspension

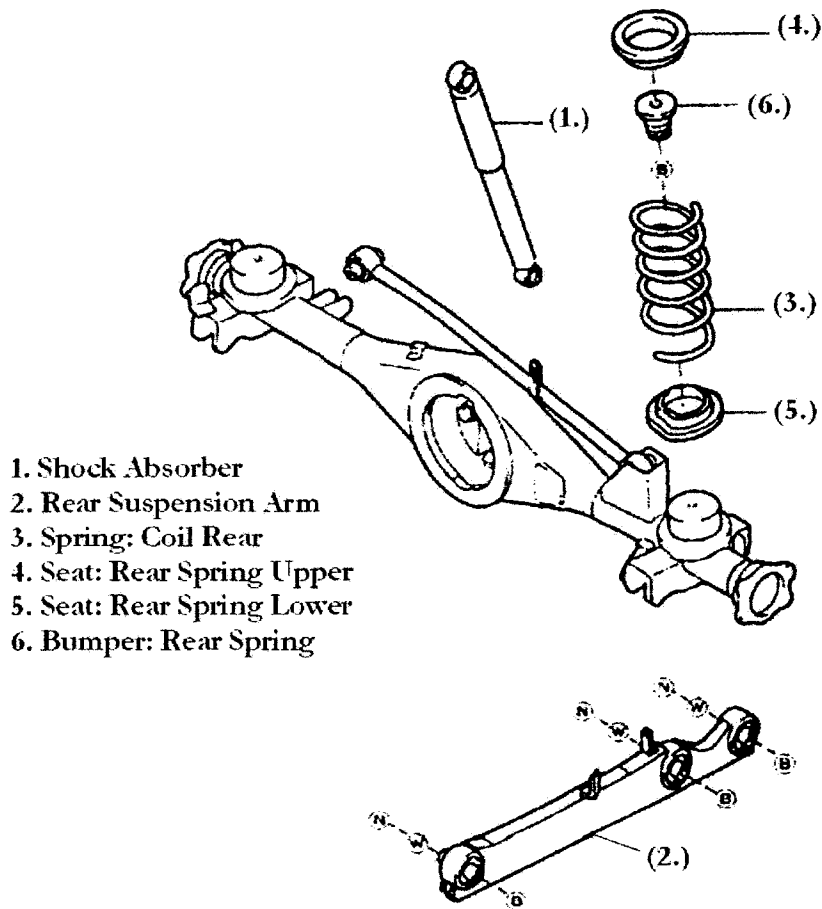

Removal

1. Jack Up Vehicle and Place Jack Stands as Shown in Diagram to Right
2. Remove Rear Wheels
3. Remove Parking Brack Cable Bracket
4. (ABS Vehicles) Remove Seansors
5. Disconnect Brake Hose

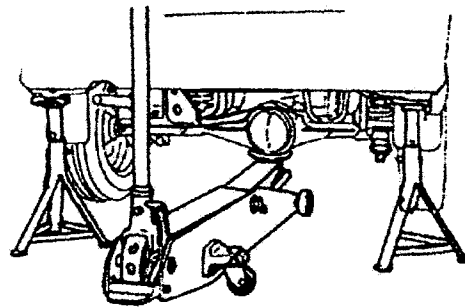

Suspension

Rear Coil Spring & Differential Removal

6. Remove Lower Shock From Axel Housing

Note: Bolt Must Be Replaced

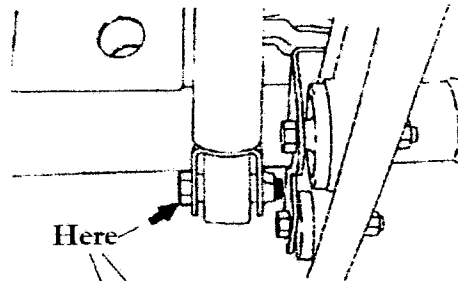

7. Disconnect Rear Suspension Arm from Axel Housing. Use Diagram on Right

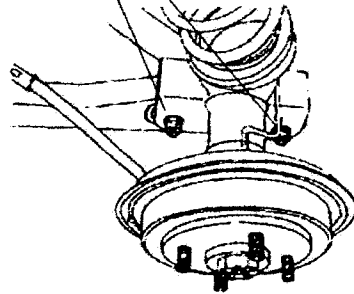

8. Remove Rear Suspension Arm From Mount and Remove Arm

9. Inspect for any Optional Wires Attached to Axel, If Attached, Disconnect or Remove

10. Lower Axel from Vehicle

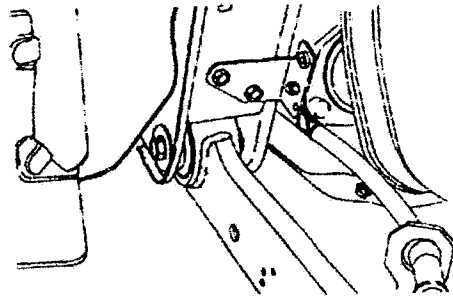

11. Inspect Suspension Arm Bushings and Replace if Necessary Before Re-Installation

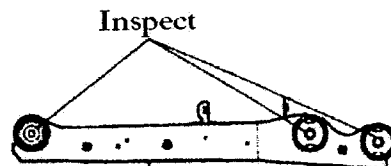

Suspension

Rear Lateral Control Rod Assembly

Rear Coil Spring Vehicle

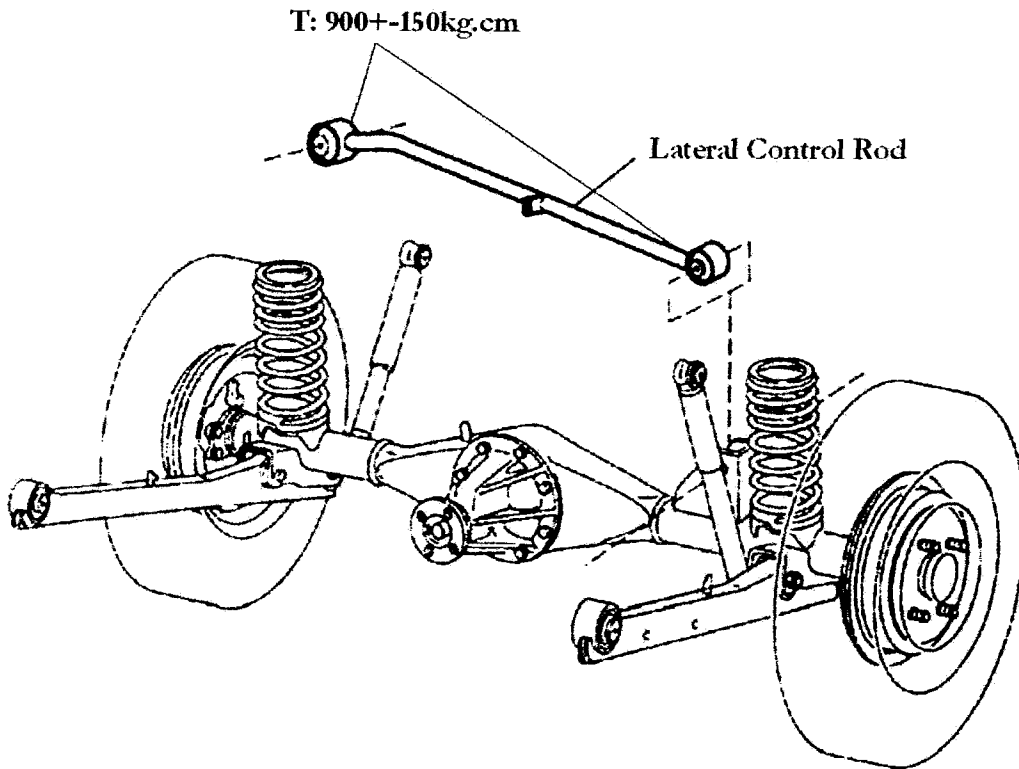

Suspension

Front Strut & Coil Parts

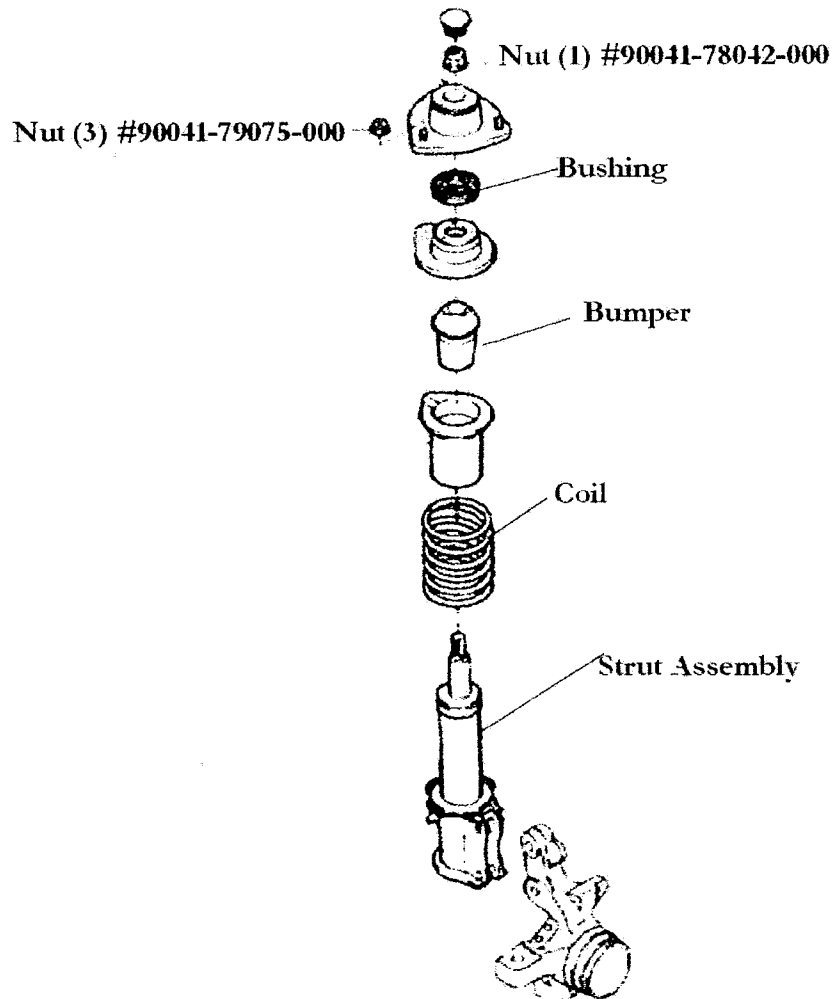

Note: Parts Listed Below Available at Time of Publication

Bumper: (All) #48331-87507-000

Strut Assembly:

EFNS, EFES, EFTS (VAN) DX,HX,MTM,2WD,NTBO

(RH)#48510-87553-000

(LH)#48520-87548-000

S100, S110 (tRUCK) MT,DUMP,NGD,

(RH)#48510-87561-000

(LH)#48520-87556-000

Bushing: (All)#90043-86101-000

Coil (Truck)#48131-87564-000

(Van) #48131-87566-000

Suspension

Rear Leaf Spring Suspension Parts

Truck - Van - MT - Deck

(N)=Nut Part#
(B)=Bolt Part#
(W)=Washer Part#

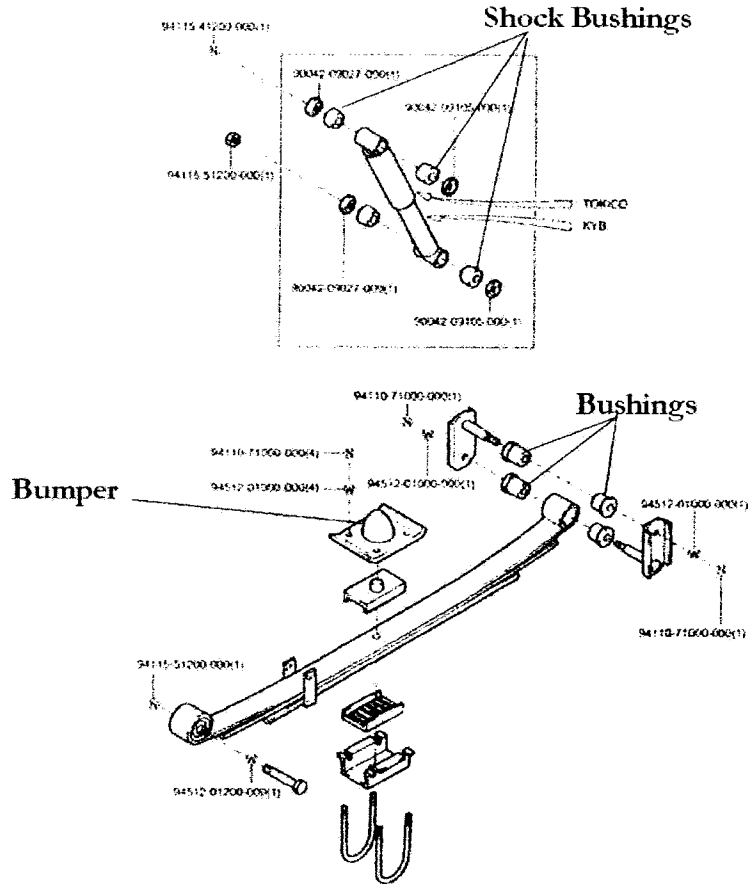

Bumper

Truck #48341-87520-000

Van #48341-87521-000

Note: Available Parts Listed to Left

Bushings

(All) #90043-85158-000

Shock Absorber

Van #48531-87592-000

Truck #48531-87593-000

Shock Absorber Bushings

S110,110,140 #90043-85002-000

S120,130 #90043-85146-000

Suspension

Front Suspension Parts

(B)=Bolt
(W)=Washer
(N)=Nut

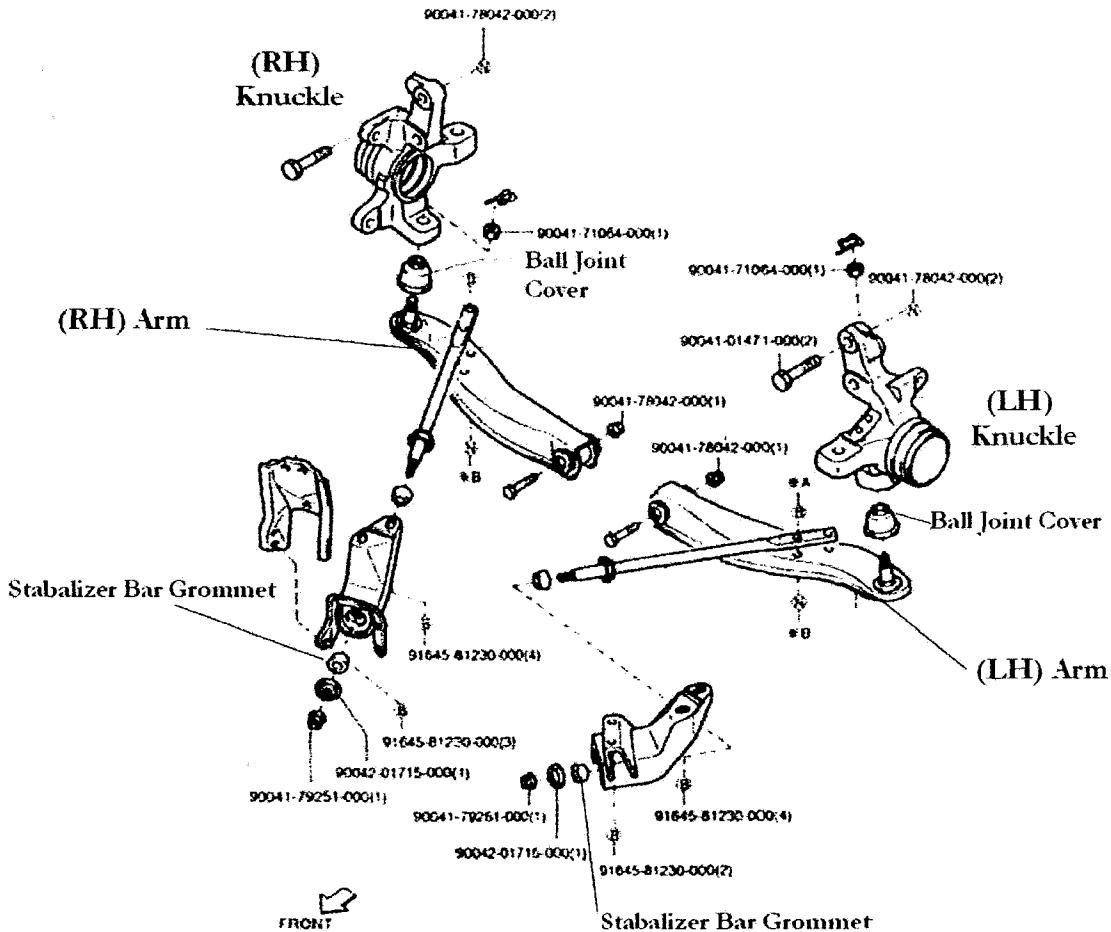

Knuckle

(RH) #43211-87517-000

(LH) #43212-87513-000

Ball Joint Cover (ALL) #43345-87508-000

Arm: Lower Suspension

(RH)

EFTS, EFGS, EFGS, EFZS, NTBO #48605-87519-000

Turbo#48605-87520-000

(LH)

EFTS, EFGS, EFGS, EFZS, NTBO #48606-87520-000

Turbo#48606-7521-000

Stabilizer Bar Grommet (All) #48674-87505-000

Chapter 5

Brake System

- **Brake Pedal & Bracket Diagram**
- **Master Cylinder Breakdown Diagram**
- **Master Cylinder Type (Standard-ABS) & Rebuild**
- **Parts: Master Cylinder Van-Truck**
- **Parts: Brake Booster**
- **Front Disk Brake System 2WD**
- **Front Disk Brake System 4WD**
- **Front Caliper Breakdown Diagram & Parts Listing**
- **Rear Drum Brake System & Parts**
- **Parking Brake Diagram & Parts**
- **ABS Control Unit**
- **ABS Front & Rear Sensor Diagrams**
- **ABS Computer**
- **ABS Complete Control Circuit Schematic 2WD**
- **ABS Complete Control Circuit Schematic 4WD (Including Diff-Lock)**

Brake System

Brake Pedal & Bracket Diagram

T: =Torque kg.cm

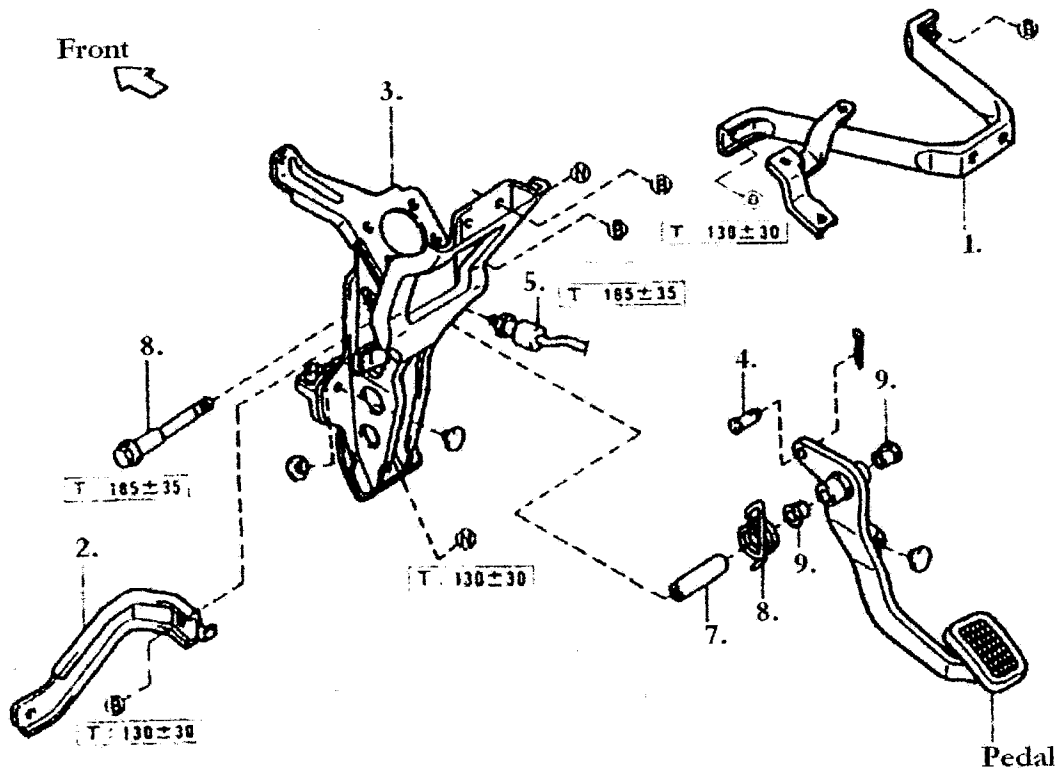

1. Steering Column Bracket
2. Bracket: Fuse Block
3. Support: S/S, Pedal Bracket
4. Link Pin
5. Stop Lamp Switch Assembly
6. Retainer Bolt
7. Spacer
8. Torsion Spring
9. Bushing
10. Brake Pedal

Brake System

Master Cylinder Breakdown Diagram

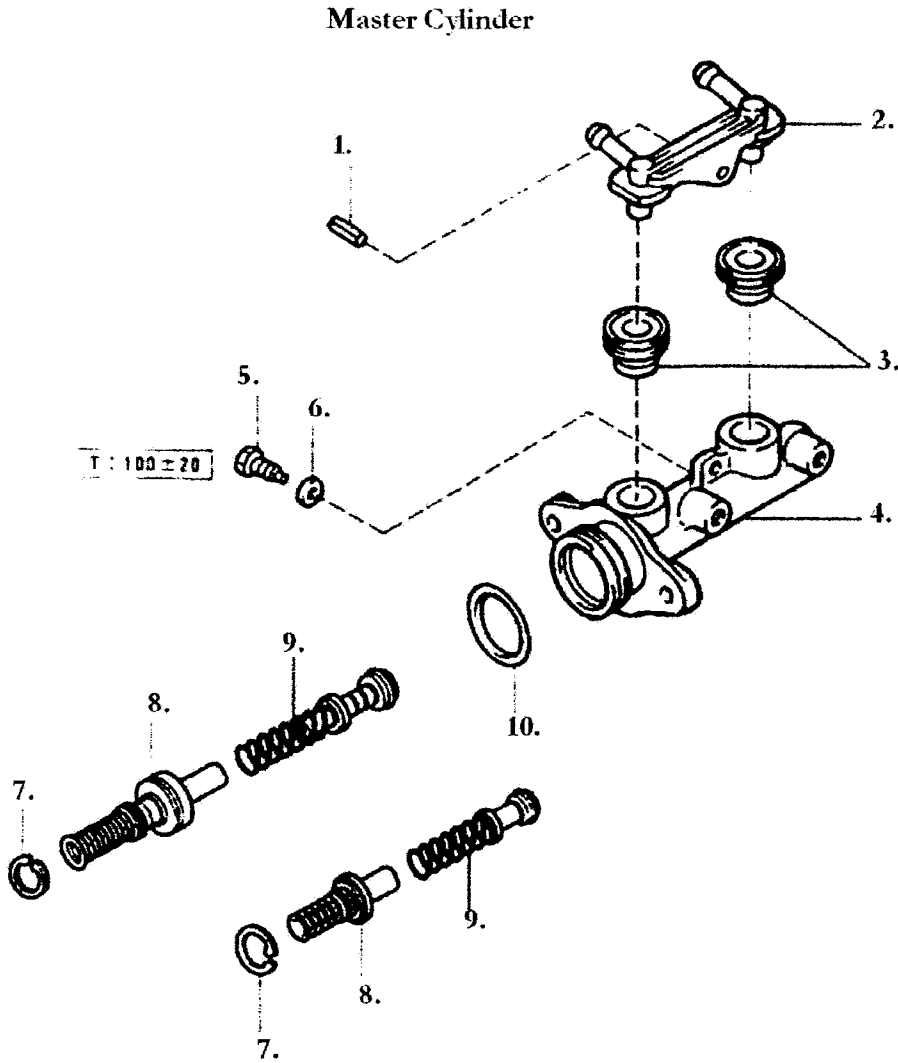

1. Pin
2. Union Inlet
3. Grommet (Must Replace)
4. Master Cylinder Body
5. Bolt Set (Lock)
6. Gasket (Must Replace)
7. C-Ring
8. Piston Assembly No.1
9. Piston Assembly No.2
10. O Ring

Brake System

Master Cylinder Type & Rebuild

6 Inch Type

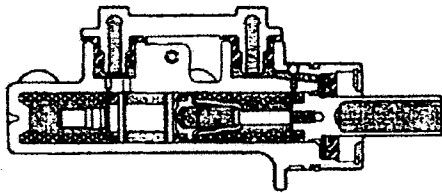

7 Inch Type

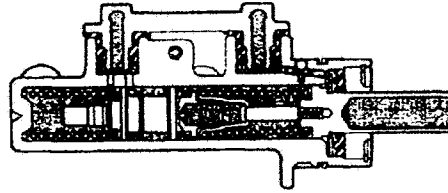

ABS Type 8 Inch

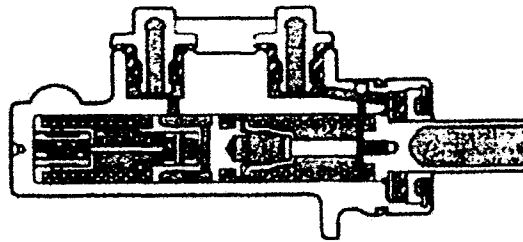

Master Cylinder Disassembly

1. Remove Master Cylinder
2. Remove Retaining Screw From Union Joint Cover. See Right Diagram
3. Remove Rubber Grommets(Replace)
4. Place Master Cylinder Body in a Vise as Shown on Right. Place Bolt Mounting Pad Ear in Vise. Do Not Over Tighten
5. Use a Driver to Push Piston Forward, Remove Set Bolt

Note: All Gaskets & Grommets Must be Replaced

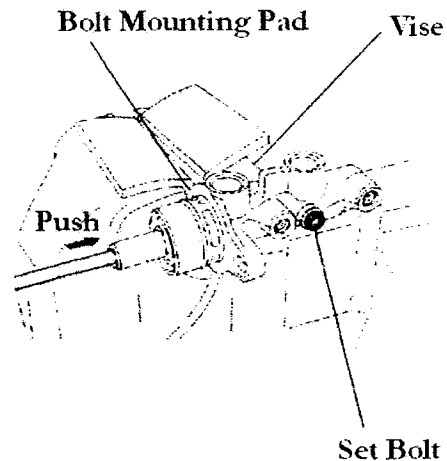
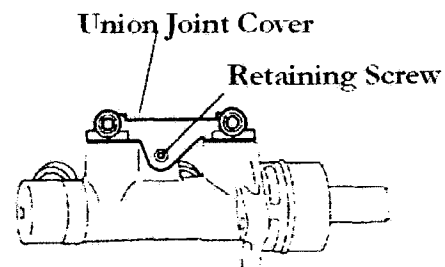

Brake System

Master Cylinder Rebuild

7. While Holding Pressure Forward Use Snap Ring Pliers and Remove Snap Ring.

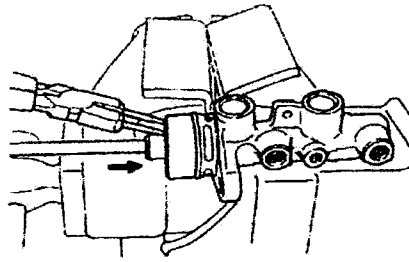

- Note: If Piston Unit Does Not Slide Out Hold Upside Down as in Diagram on the Right. Place Two Wood Blocks in Vise and Tap Unit Unit Piston Unit Slides Out

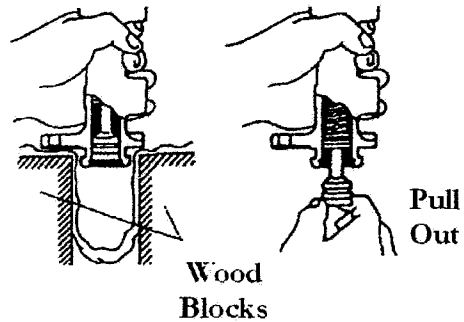

Master Cylinder Assembly

Two Piston Types

- Note: Before Assembly Carefully Inspect Complete Unit and Thoroughly Clean All Parts



Non-ABS Type

1. Assemble New Piston Unit

- Note: ABS & Non-ABS Are Not Interchangeable

2. Coat Inside of Master Cylinder With Fresh DOT Type 3 or DOT4 Brake Oil



ABS Type

- Note: Never Re-Use Gaskets & Grommets

Brake System

Master Cylinder Rebuild

3. Slide Pre-Oiled Piston Unit Into Master Cylinder Assembly

Note: Do Not Force

4. Replace Snap Ring

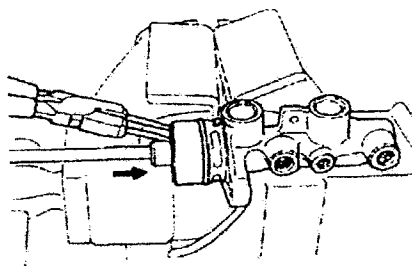

Set Bolt Torque: 100+-20kg.cm

5. Push Piston Unit Forward and Install Set Bolt

6. Remove From Vise and Install New Grommets

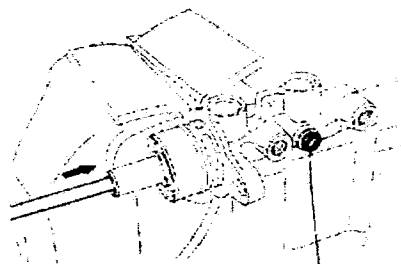

Set Bolt

7. Attach Union Cover Plate With Set Screw

8. Install Unit

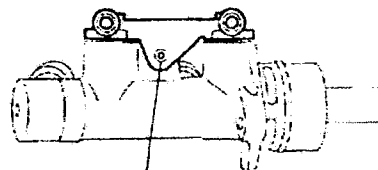

Set Screw

Brake System

Parts: Master Cylinder

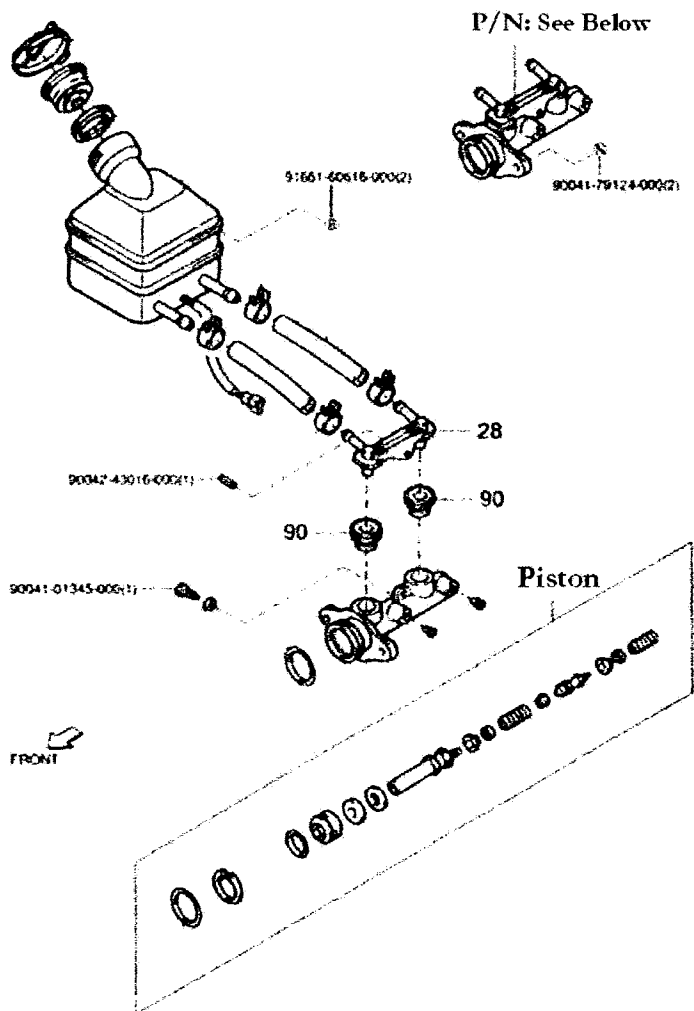

Master Cylinder Assembly

	Assembly P/N	Rebuild Kit P/N
Van/Truck (MT,MTM,NTBO-HX)	#47201-87518-000	#04471-87524-000
Van(EFI-HX,ATM,TBO)	#47201-87519-000	#04471-87525-000
Truck(TR,CAB)	#47201-87518-000	#04471-87524-000
Van/Truck(DOHC,CRM,PF2)	#47201-87518-000	#04471-87524-000

Brake System

Parts: Brake Booster

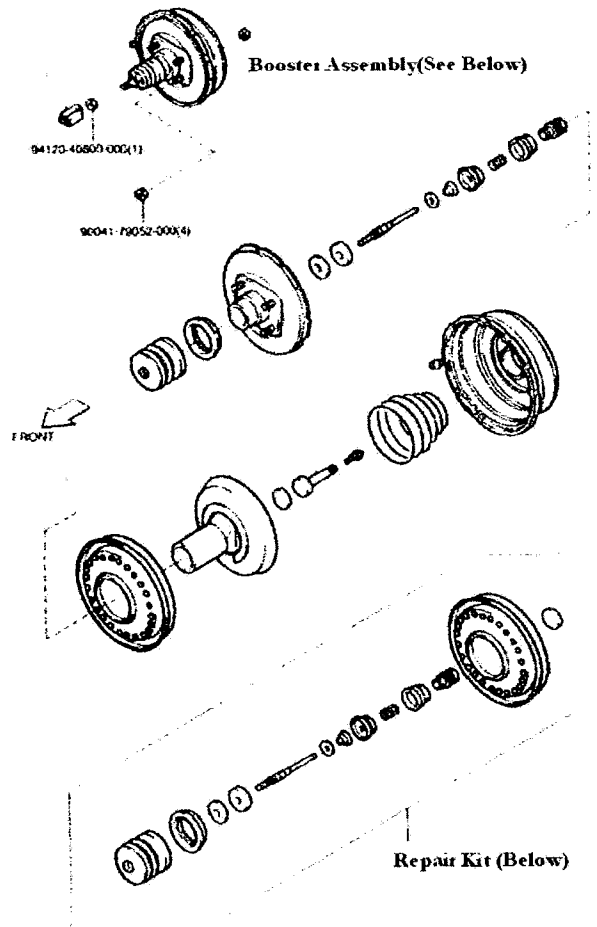

Brake Booster Assembly

Truck/Van (TR,MT,MTM,NTBO-HX)

Van (EFI, HX, ATM, TBO)

All Others

Assembly Unit

#44610-87519-000

#44610-87520-000

#44610-87519-000

Repair Kit

#04443-87513-000

#04443-87514-000

#04443-87513-000

Brake System

Front Disk Brake System 2WD

Truck & Van 2WD

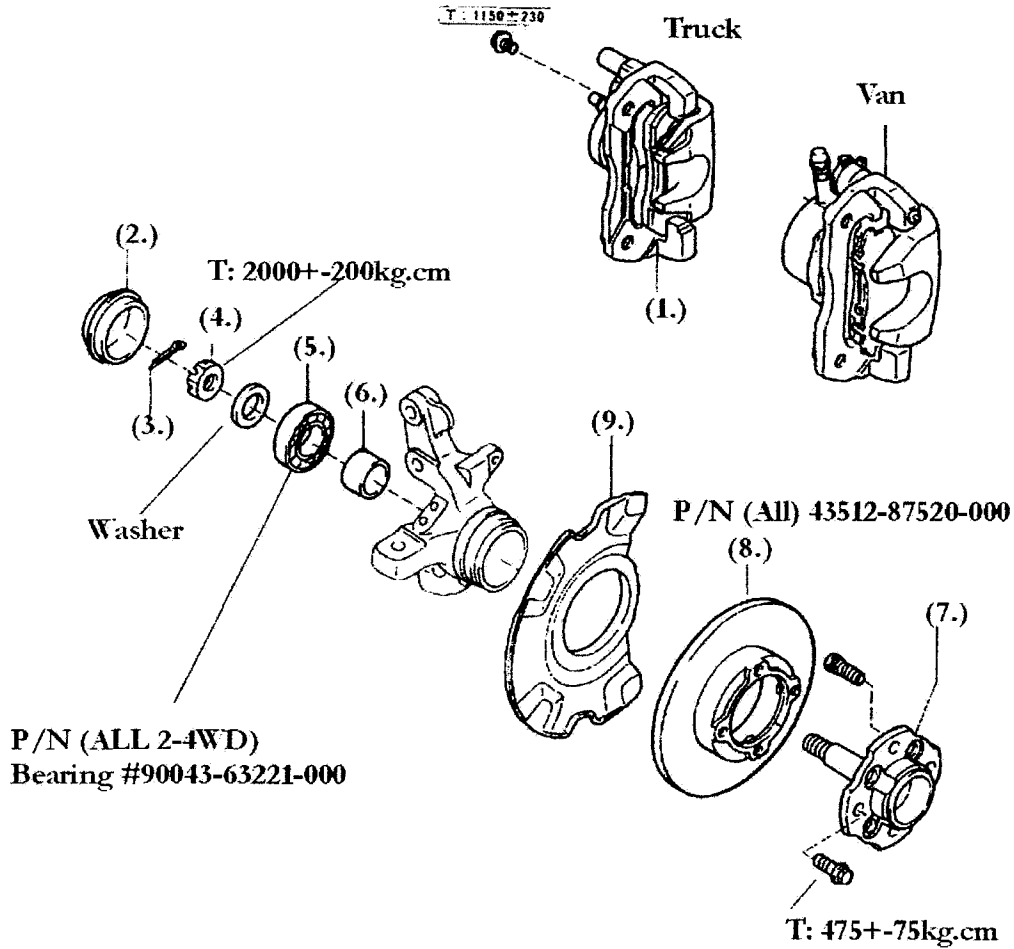

1. Front Disk Brake Caliper
2. Front Hub Grease Cup
3. Cotter Pin (Replace)
4. Castle Nut
5. Wheel Bearing
6. Collar
7. Spindle
8. Front Disk Rotor
9. Dust Cover

Brake System

Front Disk Brake System 4WD

Truck & Van 4WD

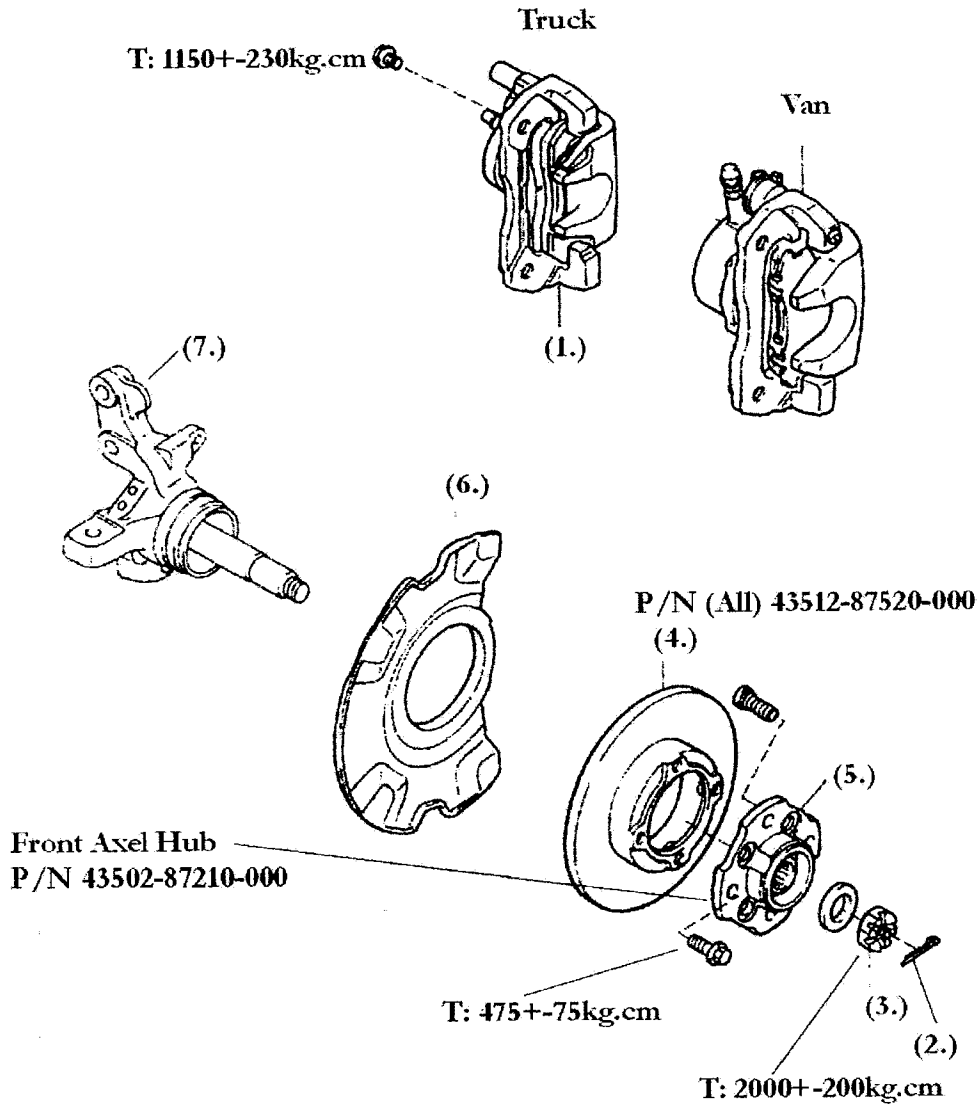

1. Front Disk Brake Caliper
2. Cotter Pin
3. Castle Nut
4. Front Disk
5. Hub: Front Axel
6. Dust Cover
7. Knuckle

Brake System

Front Brake Caliper System

Truck & Van

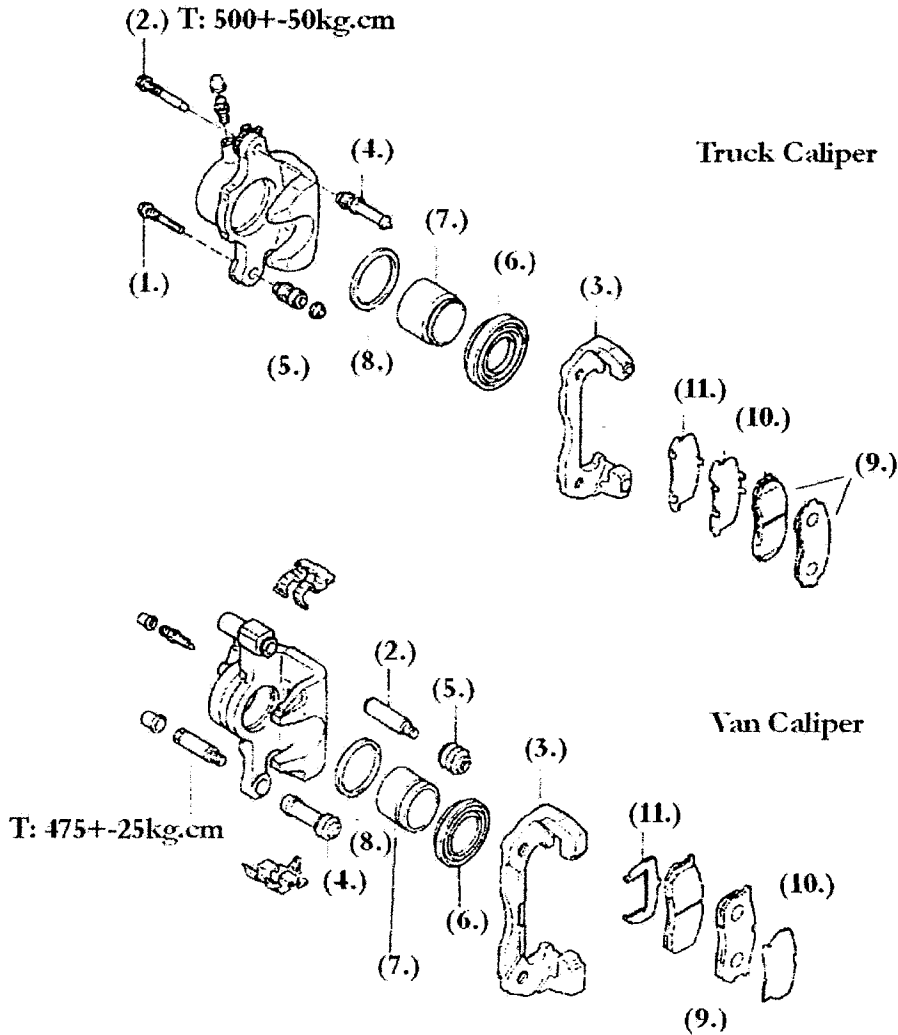

1. Pin: Main
2. Pin: Sub
3. Bracket: Caliper Attachment
4. Bushing: Cylinder Slide
5. Boot: Cover
6. Seal
7. Disk Brake Caliper Piston
8. Seal: Piston
9. Disk Brake Pads
10. Shim (Anti-Squeal)
11. Shim (Anti-Squeal)

Parts List

Caliper

Van (All) P/N 47720-87516-000

Truck (All) P/N 47710-87515-000

Pad Kit

Van (All) P/N 04491-87509-000

Truck (All) P/N 04491-87506-000

Caliper Rebuild Kit

Van (All) P/N 04479-87504-000

Truck (All) P/N 04479-87503-000

Brake System

Drum Brake Components & Part Numbers

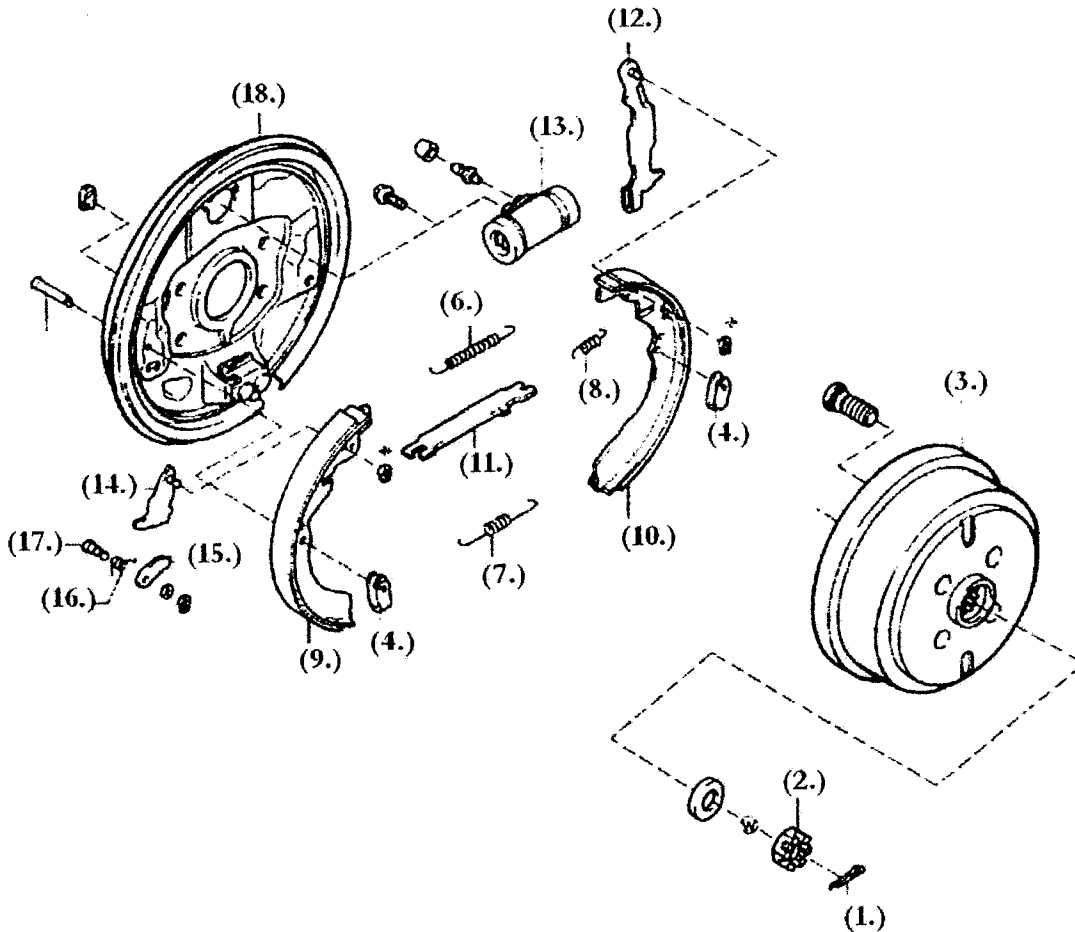

1. Pin: Cotter
2. Nut: Castle T: 2000+-200kg.cm
3. Drum
4. Spring: Shoe-Hold down
5. Pin: Shoe -Hold Down Spring
6. Spring: Tension
7. Spring: Tension
8. Spring: Tension
9. Brake Shoe No.1
10. Brake Shoe No.2
11. Strut
12. Parking Brake Lever
13. Wheel Brake Cylinder
14. Latch: Automatic Adjuster
15. Lever: Automatic Adjuster
16. Spring: Tension
17. Pin: Adjuster
18. Back Plate

Major Part Numbers

Brake Shoe(s)
 Brake Shoe No.1 (All) 47420-87512-000
 Brake Shoe No.2 (All) 47430-87514-000
 Note: Daihatsu Order Shoes Separately

Wheel Cylinder Assembly
 Right Side
 Normal: 47550-87509-000
 ABS: 47550-87517-000

Left Side
 Normal: 47560-87509-000
 ABS: 47560-87520-000

Brake System

Parking Brake System

Truck & Van

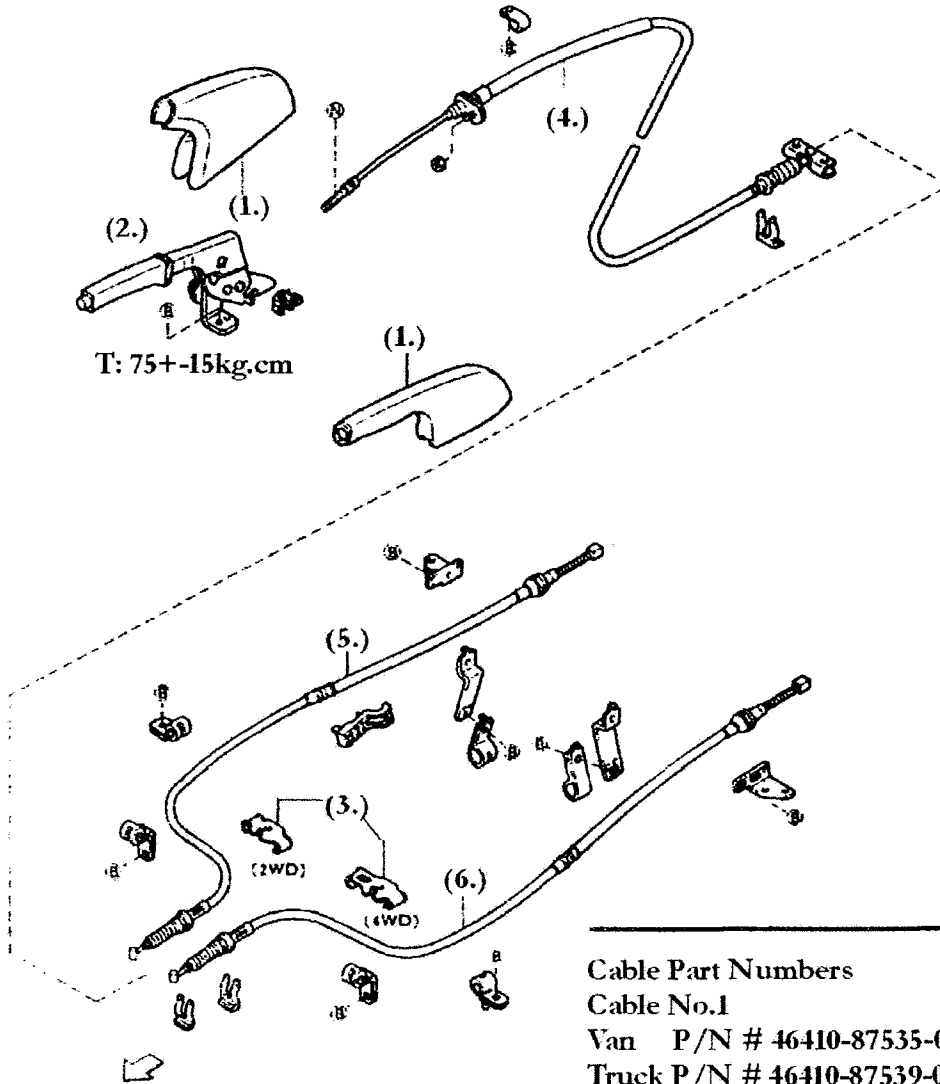

1. Cover: Parking Brake Lever
2. Lever Assembly
3. Clamp
4. Cable No.1
5. Cable No.2
6. Cable No.3

Cable Part Numbers

Cable No.1

Van P/N # 46410-87535-000

Truck P/N # 46410-87539-000

Cable No.2

Van P/N # 46420-87514-000

Truck P/N # 46420-87507-000

Cable No.3

Van P/N # 46430-87507-000

Truck P/N # 46430-87506-000

Brake System

ABS Control Unit

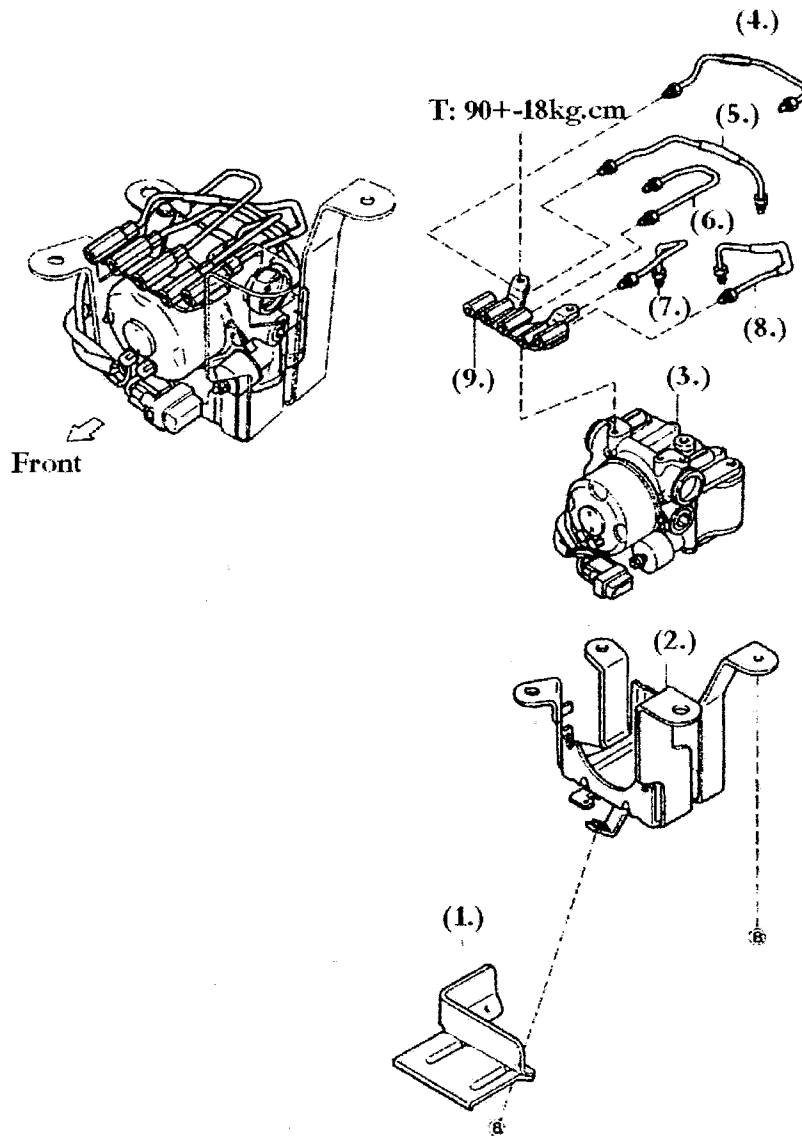

1. Bracket: Brake Actuator No.2
2. Bracket: Brake Actuator No.1
3. Actuator Assembly
4. Tube: No.1
5. Tube: No.2
6. Tube: No. 3
7. Tube: No.4
8. Tube: No.5
9. Two-Way Valve

Brake Systems

ABS Front Speed Sensor

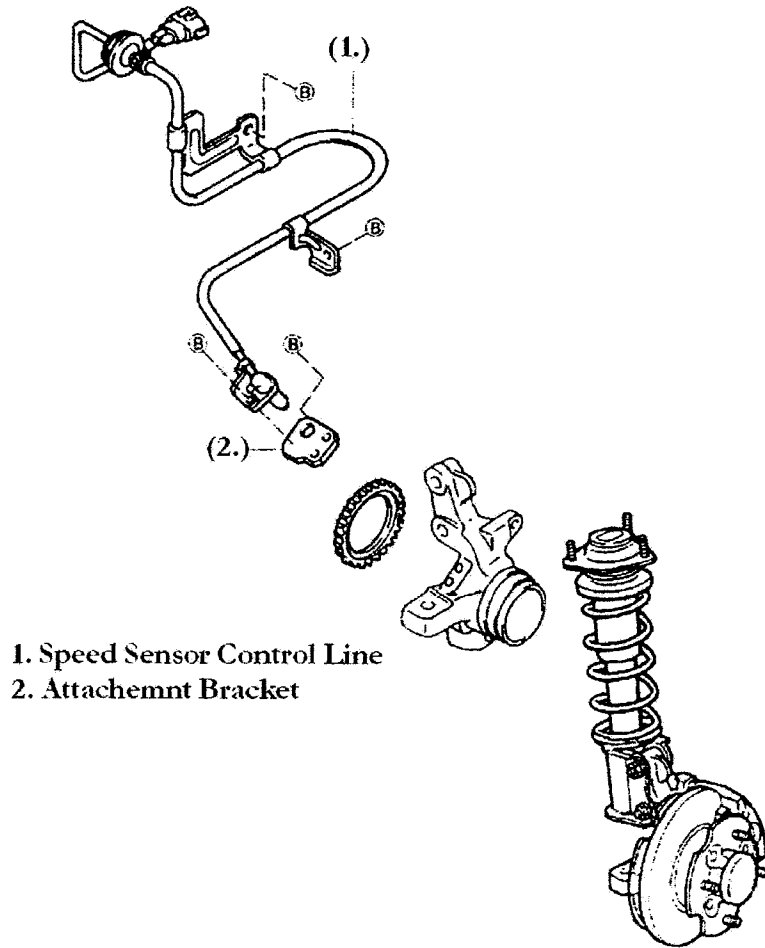

- 1. Speed Sensor Control Line
- 2. Attachment Bracket

Note: ABS Part Numbers are Vehicle VIN Specific

Brake System

ABS Rear Sensor Location

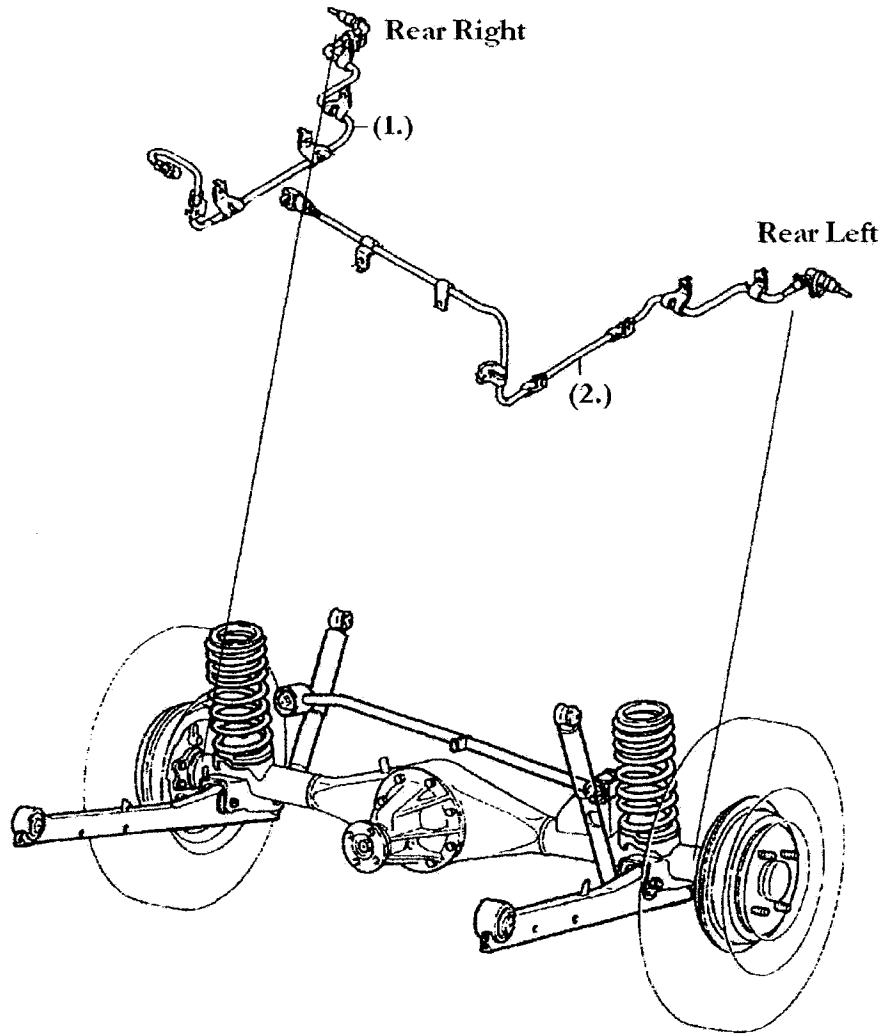

- 1. Sensor: Speed Rear Right
- 2. Sensor: Speed Rear Left

Note: ABS Part Numbers are Vehicle VIN Specific

Brake System

ABS Computer Location

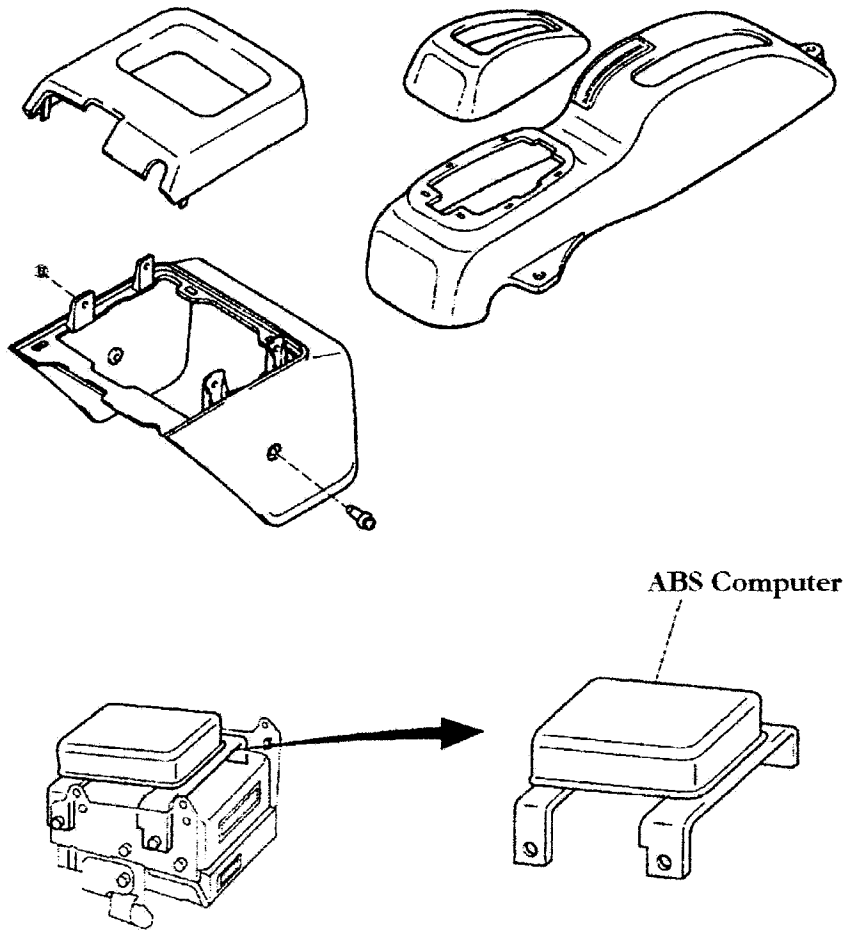

Note: All ABS parts are VIN Specific. Contact Parts Center for More Information

Brake System

ABS 2WD Control Circuit Diagram

ABS 2WD

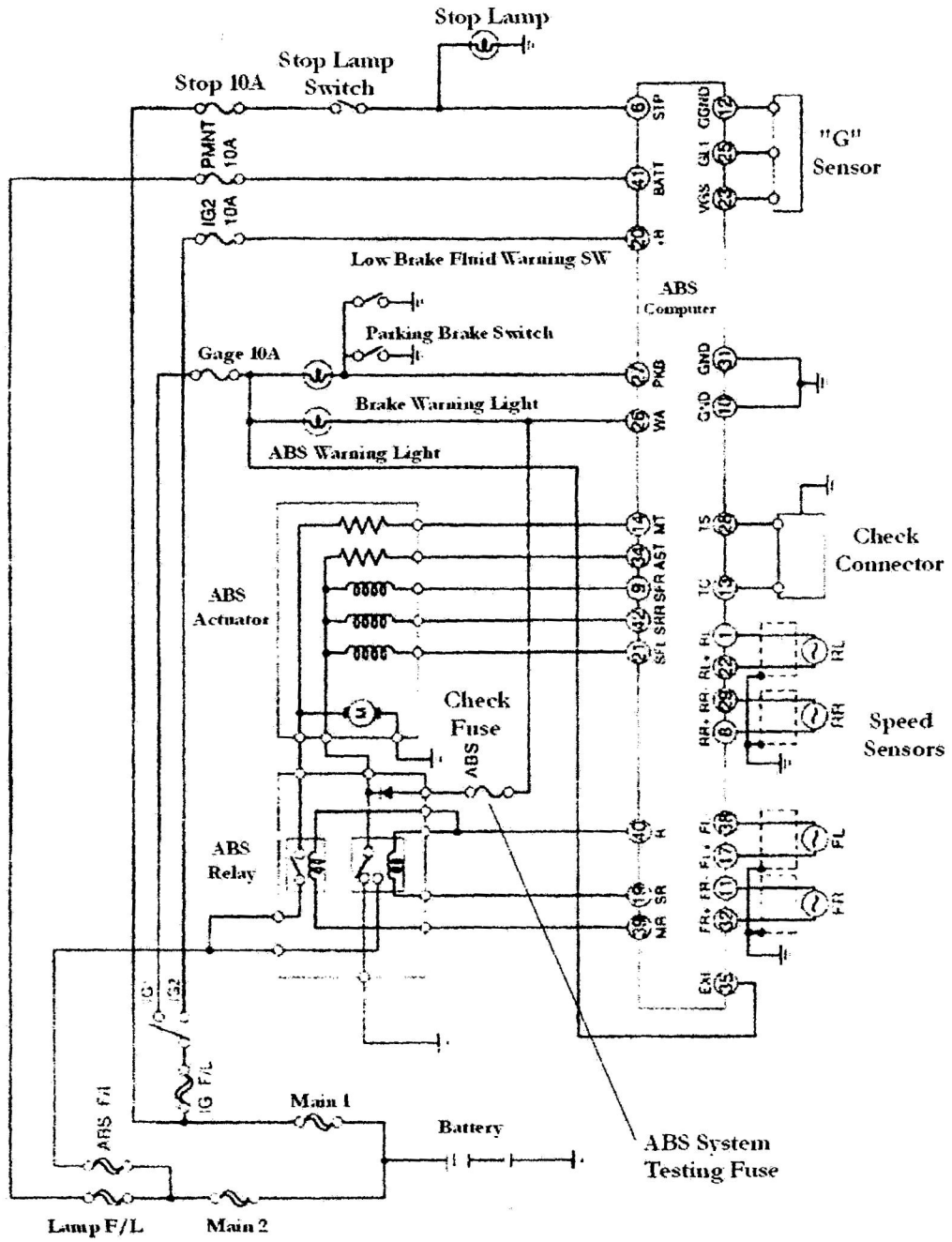

Brake System

ABS 4WD Control Circuit Diagram

ABS 4WD

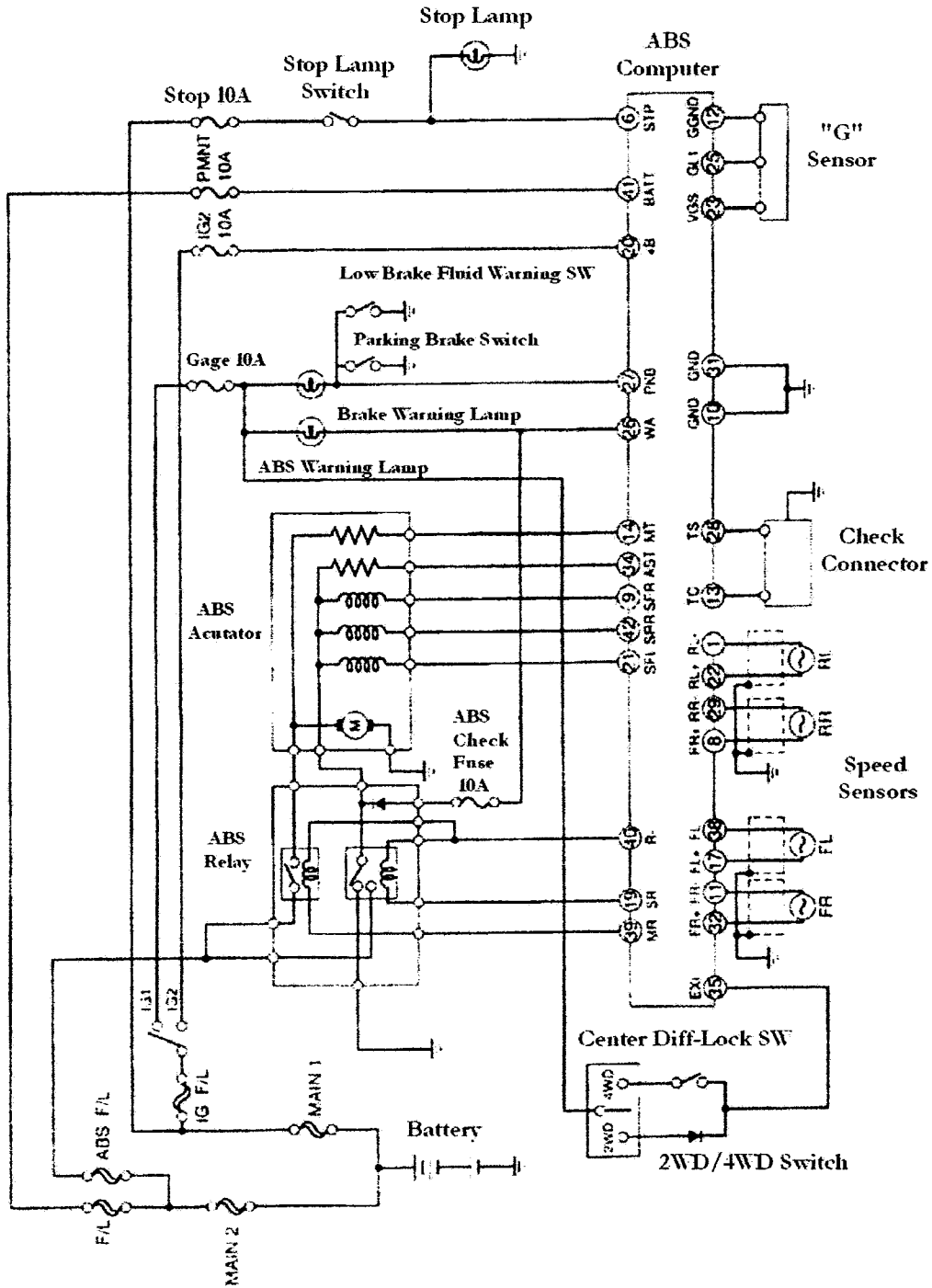

Chapter 6

Cooling System

- Radiator & Components (Truck)
- Radiator & Components (Van)
- Radiator Removal
- Radiator Fan Testing & Relay Circuit
- Radiator Thermo Control Switch Test
- Thermostat Replacement
- Thermostat Testing
- Water Pump Removal
- Water Pump Schematic & Parts EFGS, EFZS, EFRS
- Water Pump Schematic & Parts EFNS, EFES, EFTS
- Radiator & Related Parts Per Series (All Series)
- Additional Major Part Numbers

Cooling System

Radiator & Components

EFTS

Van

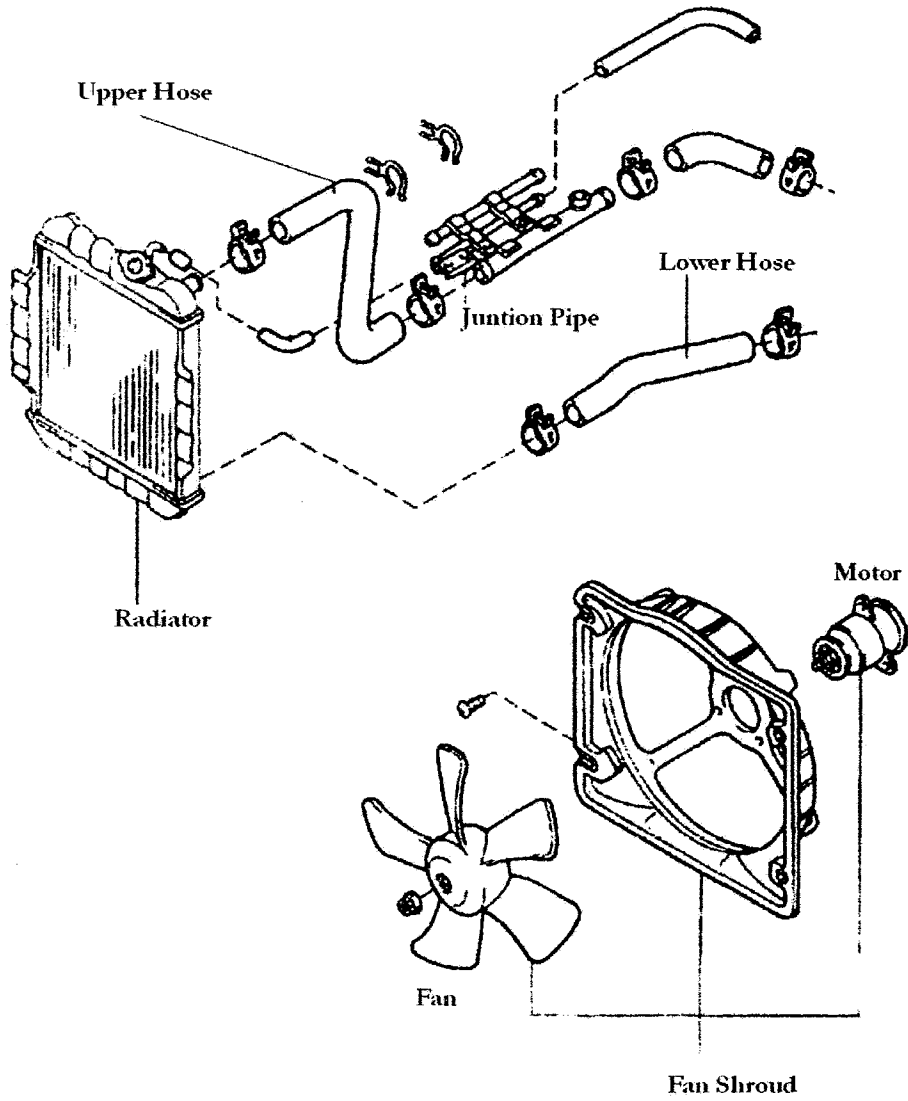

Cooling System

Radiator Removal

Caution: Never Drain While Hot

1. Disconnect (-) Battery Cable
2. Remove Front Panel
3. Open Radiator Cap and then Drain Valve. (See Diagram on Right)

Note: Never Re-Use Coolant

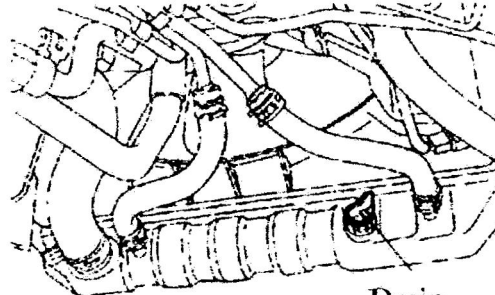

Drain
Valve

4. Remove Front Bumper
5. Disconnect Radiator Fan Coupling
6. Remove Radiator Inlet Hose

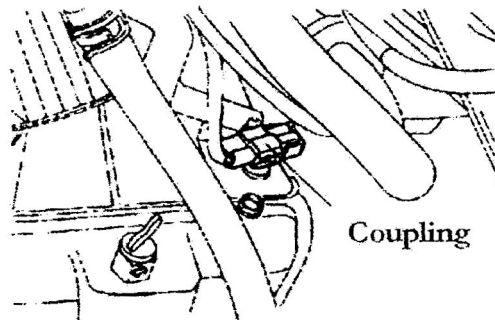

Coupling

7. (If Equiped) Remove Oil Cooler Hoses
Note: Hoses Can Not Be Re-Used

8. Remove Reserve Hose Connections
9. Remove Outlet Hose
10. Remove Fan Shroud Unit
11. Remove Radiator

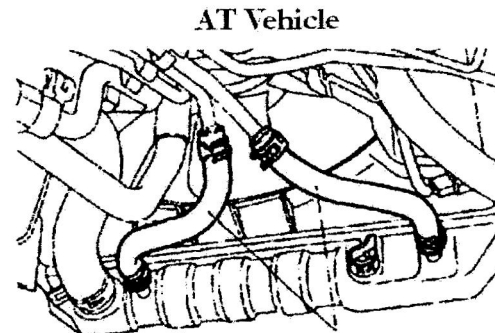

Oil Cooler Hoses

Note: Cover All Open Hoses With Plastic Bags

Cooling System

Radiator Fan Testing & Relay

Note: Under Normal Conditions Fan AMP Draw Under 10A

1. Attach Tester Warm Engine Until Cooling Fan Engages. AMP Draw over 10A Indicates Stressed Motor Condition. Check for Restriction or if No Restriction Replace Motor

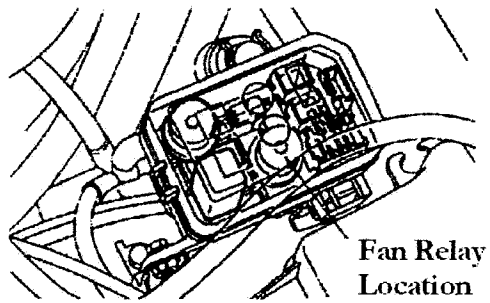
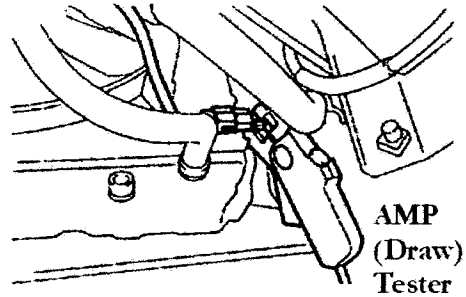

Note: If Fan Does Not Engage Replace Relay
If Relay is Replaced And Still No Engagement Replace Fan Motor

Use Diagrams on the Right For Relay Location
Van-Truck

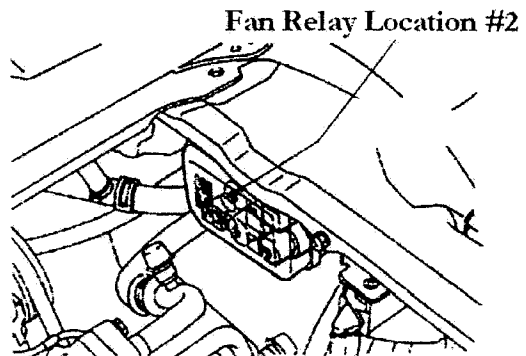

Relay Circuit

Note: Use Radiator Cooling Fan Circuit Diagram to Test Relay

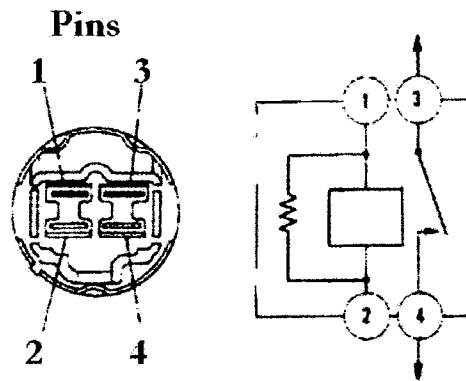

60~80 Ohm (20°C)

Cooling System

Radiator Thermo-Control Switch Test

Note: Be Careful Working Around Hot Water

1. Place Thermo-Switch In Beaker and Warm to Required Temperature
2. Test Connectivity at Selecte Temperature Ranges Listed Below

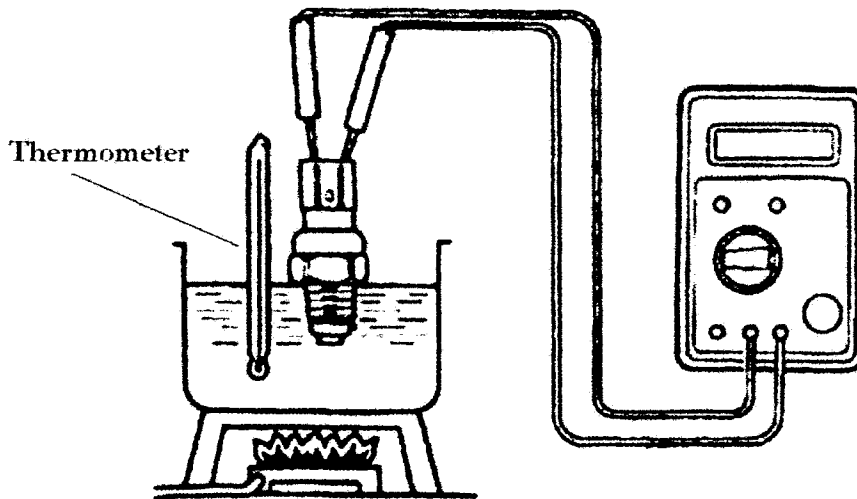

Truck (Carbureted)

Below 78°C OFF
Above 86°C ON

Truck & Van EFI

Below 90°C OFF
Above 90°C ON

Cooling System

Thermostat Replacement

Note: Never Re-Use Thermostat Gasket

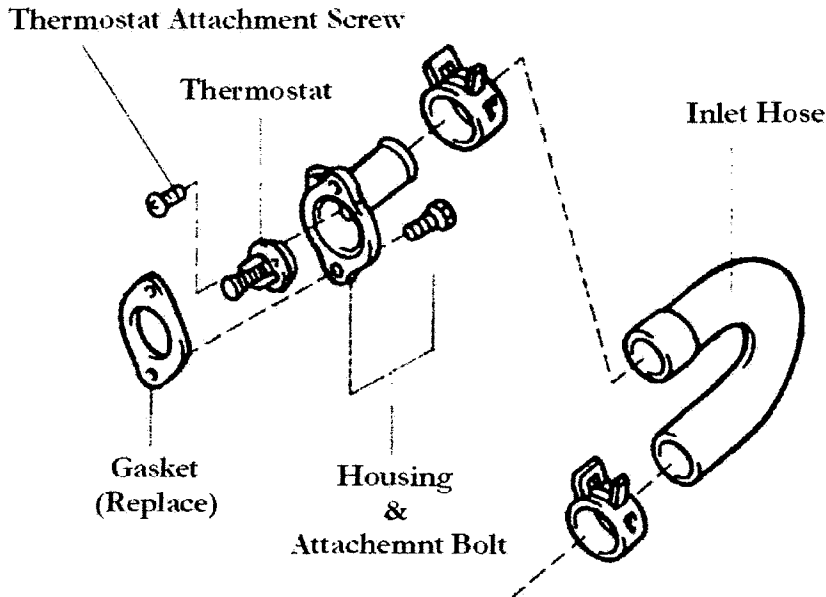

Thermostat Part Numbers

EFNS EFES EFTS #16341-87582-000 (82°C)

EFGS EFZS # 90048-33083-000 (84°C)

1. Drain Coolant
2. Remove Inlet Hose
3. Unbolt Housing and Remove Unit
4. Un-Screw Thermostat
5. Clean all Surfaces and Reverse Order Installation

Housing Bolt Torque: 75+-15kg.cm

Caution: Do Not Over Torque Bolts, Housing Will Crack

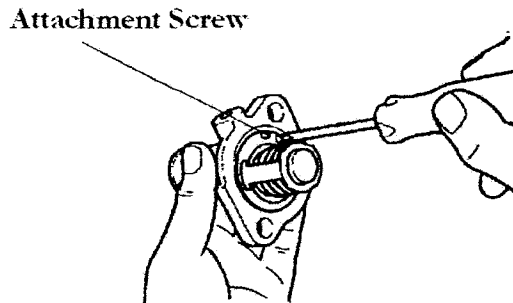

Cooling System

Thermostat Testing

1. Remove Thermostat and Check for Visible Damage or Corrosion.

Note: If Corrosion Detected Flush Entire Coolant System Before Replacing Thermostat

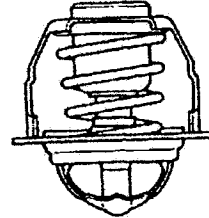

Thermostat Hot Testing
Place in Hot Water Heater in Clear Beaker
Slowly Raise Temperature and View Opening Temperature

Minimum Opening: $82 \sim 88 \pm 1.5^{\circ}\text{C}$

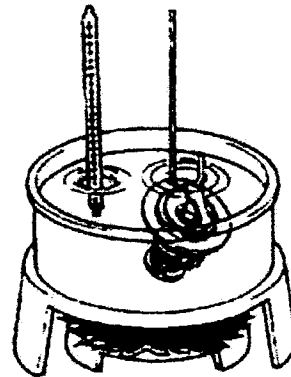

Thermostat Bulb Travel Hight

Truck 95°C 8mm
Van $95 \sim 100^{\circ}\text{C}$ 8mm

Note: Bulb Travel Less Than 8mm Replace

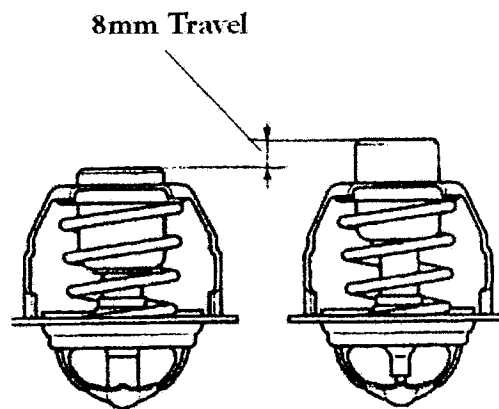

Cooling System

Water Pump Removal

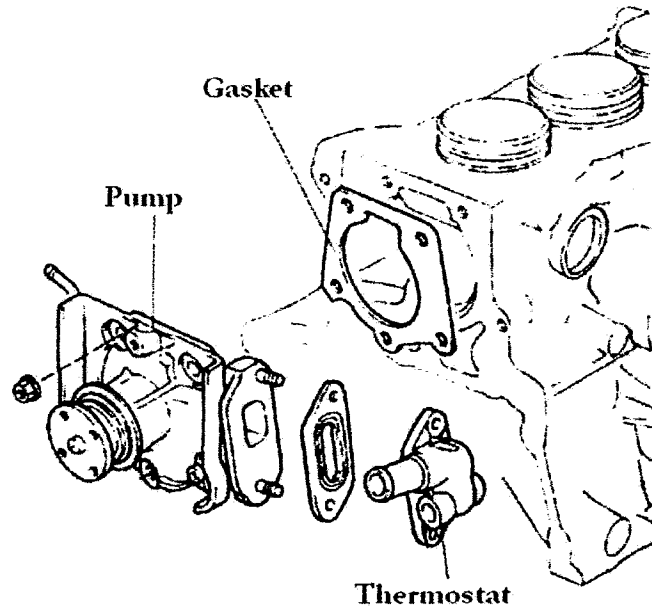

-
1. Drain Coolant System
 2. Remove Timing Belt (See Timing Belt Removal)
 3. Remove Thermostat Housing & Thermostat
 4. Remove Water Pump Attachment Bolts
 5. Remove Water Pump

Note: Do Not Re-Use Gaskets

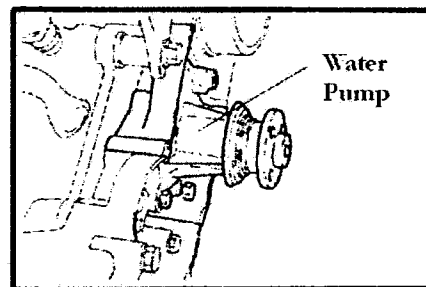

Cooling System

Parts: Water Pump

EFGS EFZS EFRS

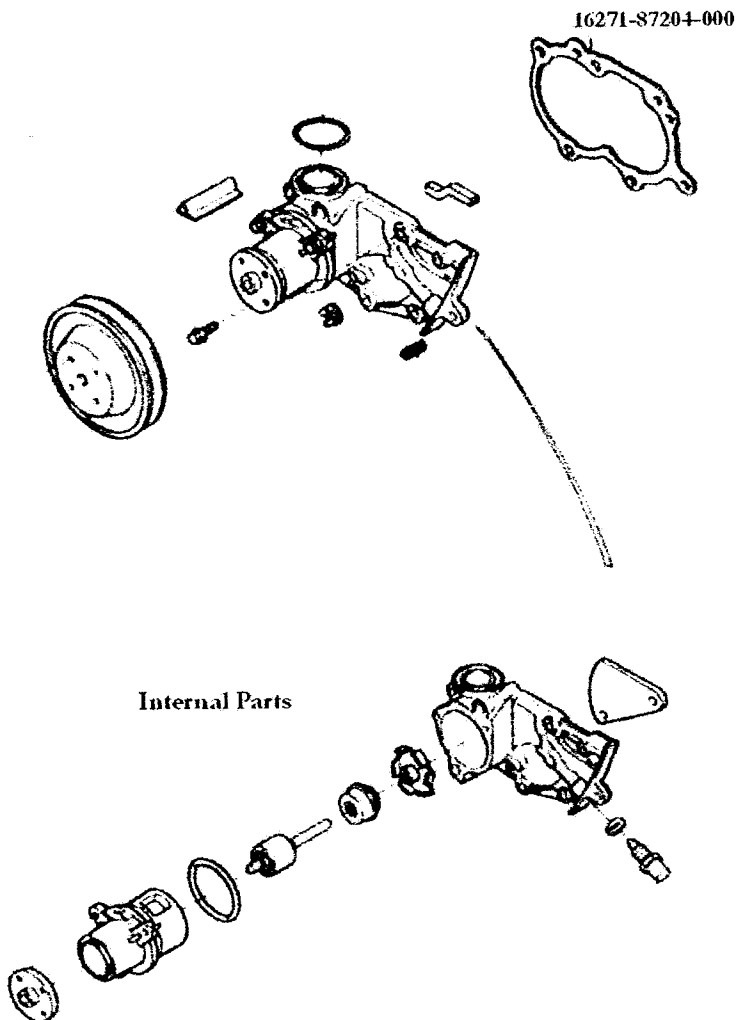

Water Pump Assembly

EF-NS,EF-ES, EF-TS S-100,S-110,S-120,S-130 Series Engines
Part# 16100-87592-000
EF-GS, EF-ZS, EF-RS Series Engines TR,DX,MX,HX,MXC
Part# 16100-87231-000

Cooling System

Parts: Water Pump & Thermostat Housing

EFNS EFES EFTS

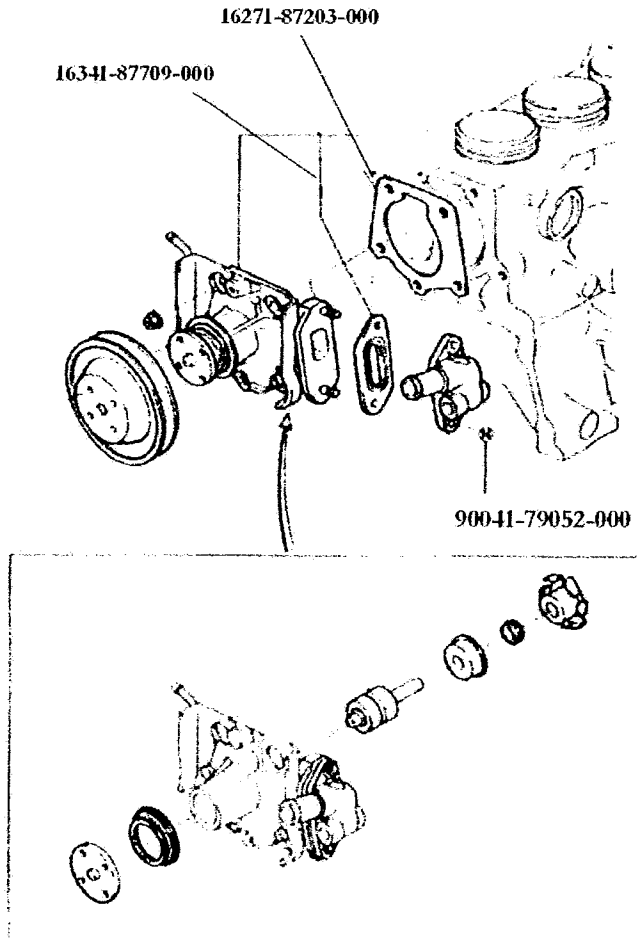

Thermostat Housing Assembly

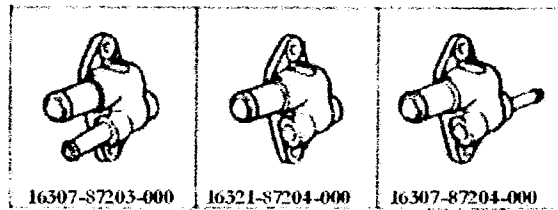

Water Pump Assembly

EF-NS,EF-ES, EF-TS S-100,S-110,S-120,S-130 Series Engines
Part# 16100-87592-000
EF-GS, EF-ZS, EF-RS Series Engines TR,DX,MX,HX,MXC
Part# 16100-87231-000

Cooling System

Parts: Radiator & Related EFNS

EFNS

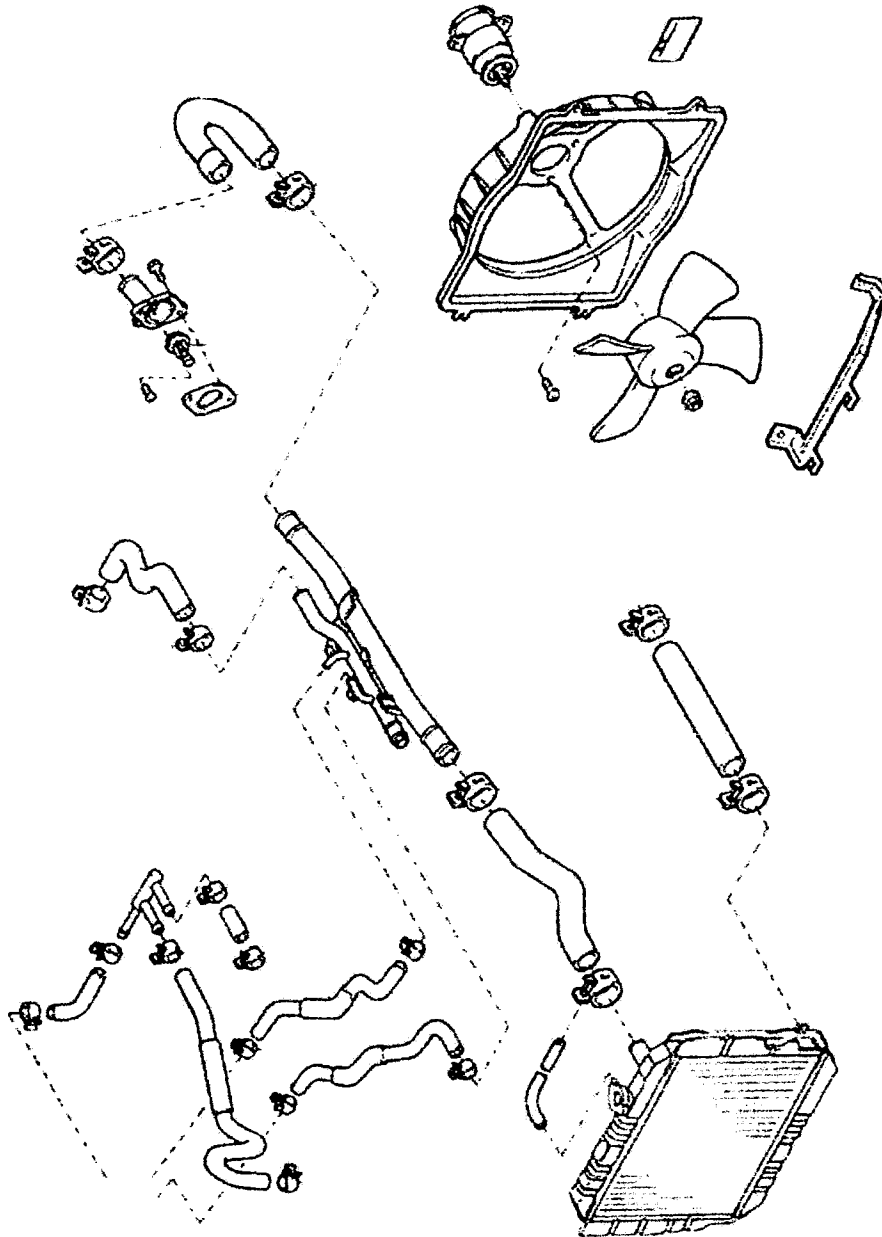

Note: See End of This Chapter for Major Parts List Per Series

Cooling System

Parts: Radiator & Related EFGS

EFGS Truck

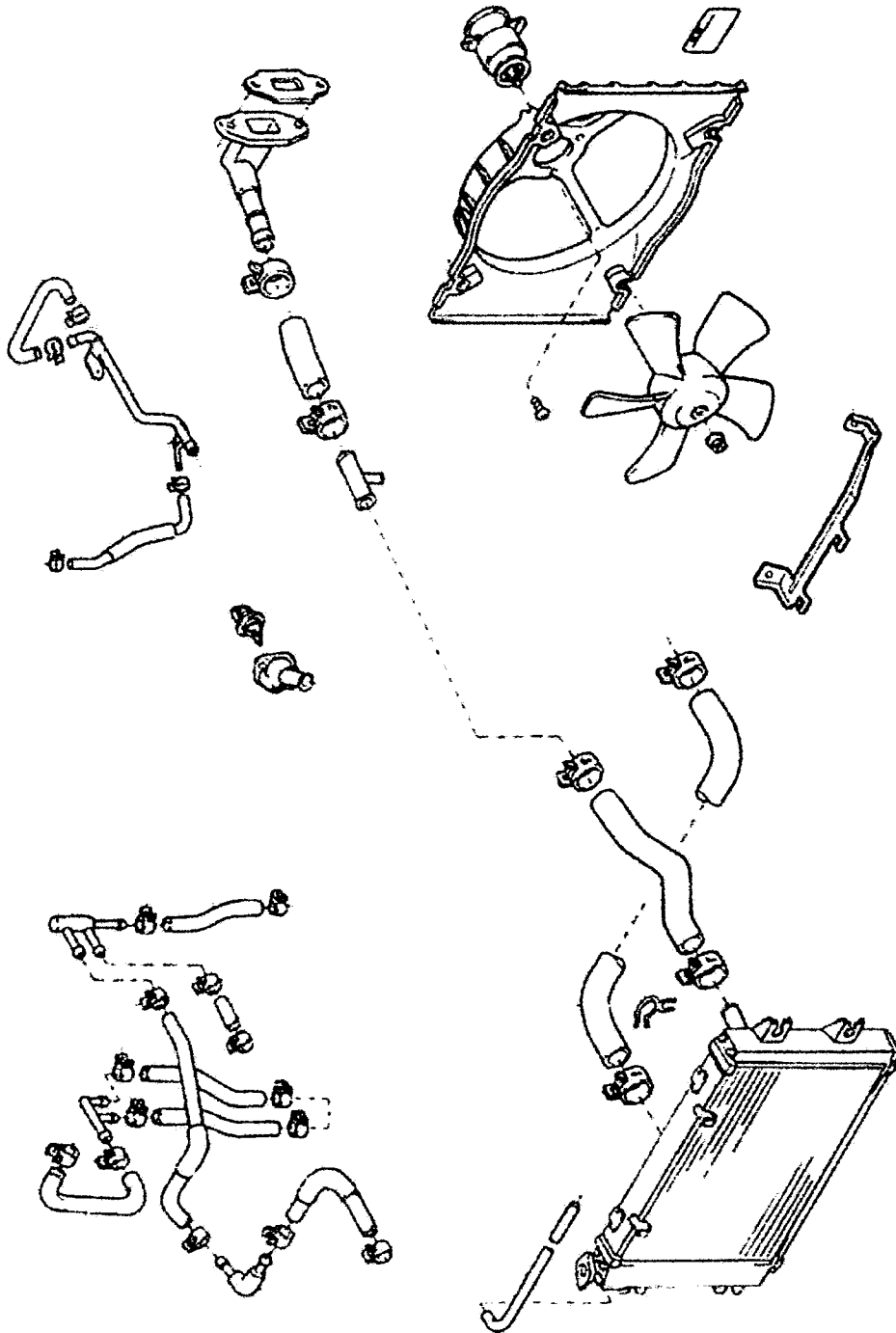

Note: See End of This Chapter for Major Parts List Per Series

Cooling System

Related Part Numbers (Major)

Radiator Assembly

EFES Van 16400-87D21-000

EFTS (MTM) 16400-87D22-000

EFTS (ATM) 16400-87D23-000

EFES (TR, MT) 16400-87D-000

EFNS, EFES VAN (MTM) 16400-78D27-000

Motor Cooling Fan

EFNS, EFES, EFTS, EFGS (MT) 1680-87518-000

EFTS, EFZS (ATM) 1680-87519-000

EFNS, EFGS (ATM & DUMP) 1680-87520-000

Radiator Inlet Hose

EFNS, EFES, EFTS (VAN) 16571-87D02-000

EFNS (S100-MT) 16571-87574-000

EFNS, EFES (TR,MT,4WD,EFI) 16571-87579-000

EFNS, EFTS, EFGS, EFZS, EFRS (S100,110,120,130 MX,MXC) 16571-87D13-000

Radiator Outlet Hose

EFNS, EFES, EFTS (VAN S100,110,130) 16572-87D04-000

EFNS, EFES (TR,MT,4WD,EFI) 16572-87D08-000

Chapter 7

Engine

- Engine Series Covered
- Engine Mounts
- Engine Mount Inspection & Limits
- Engine: Exploded Component View
- Diagnostic Connectors & Oil Specification
- Timing settings
- Timing Belt Components & Replacement
- Timing Belt Parts
- Head Gasket Removal & Replacement
- Head Gasket & Valve Cover Gasket Parts
- Valve Train Stem & Oil Seal Parts
- Oil Pump Replacement
- Oil Pump Overhaul
- Oil Pump Parts
- Oil Filter & Parts
- Piston & Block Overhaul
- Engine Parts Replacement Including Oversize Pistons & Rings
- Engine Miscellaneous Guide Pins & Part Numbers

Engine

Engine Types

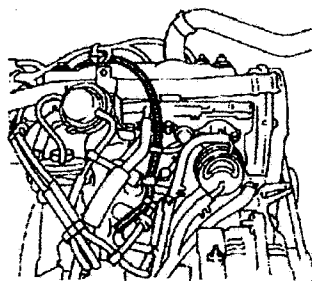
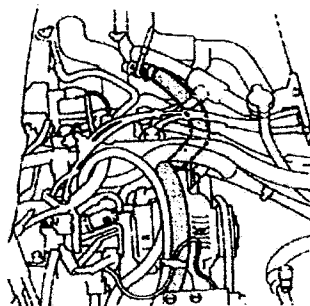
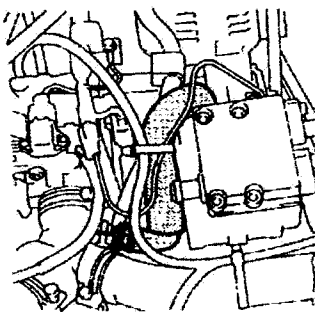
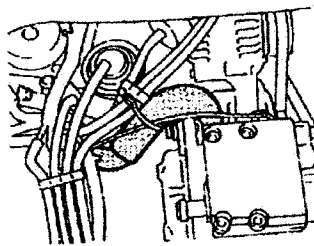

EF-NS

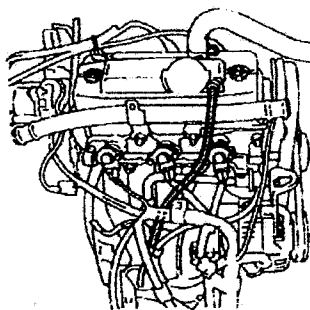

EF-ES

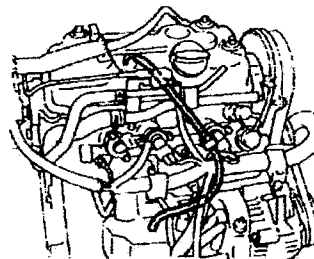

EF-TS

Engine

Engine Mounts

Torque: = kg.cm

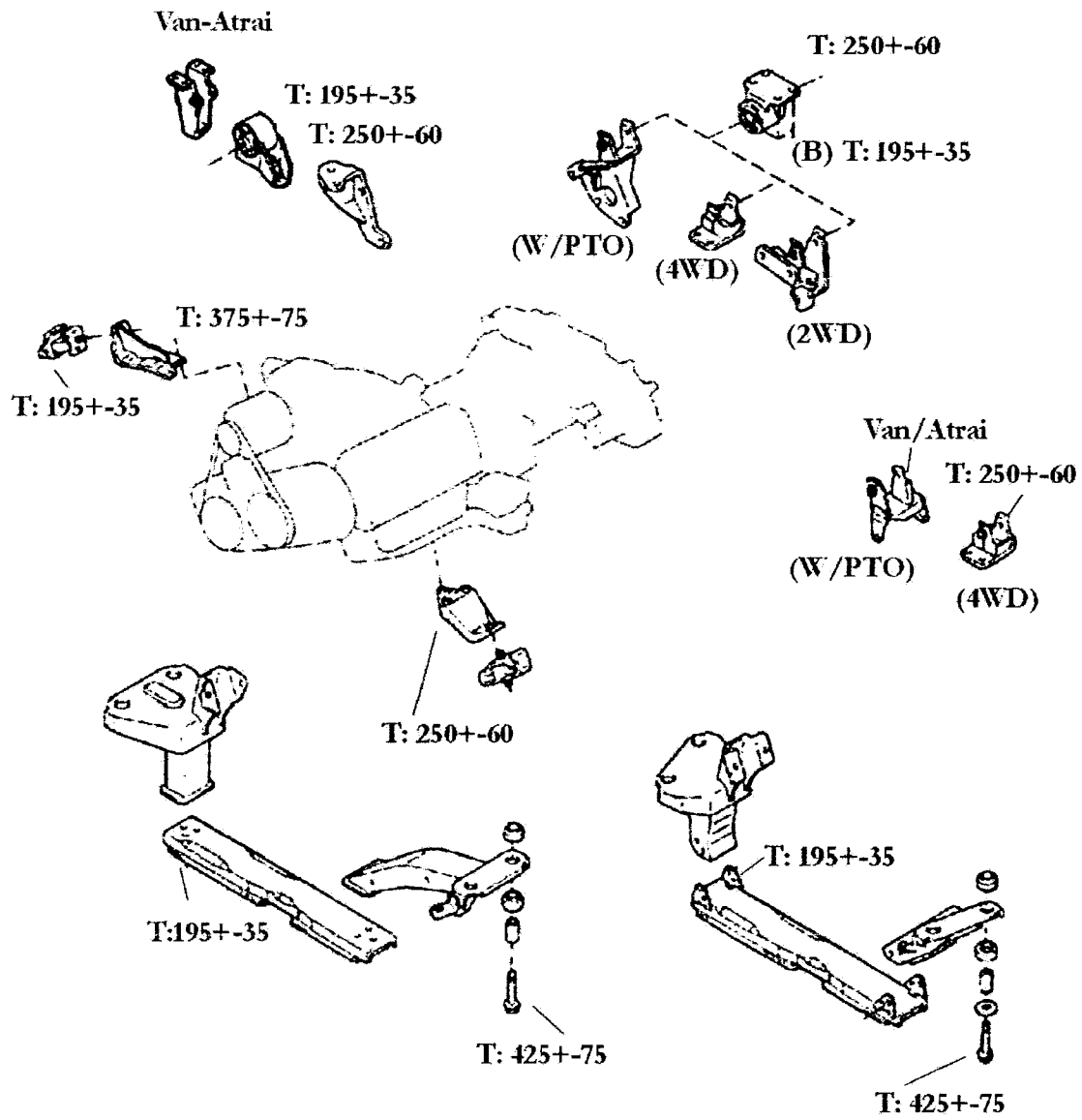

Engine

Engine Mount Inspection

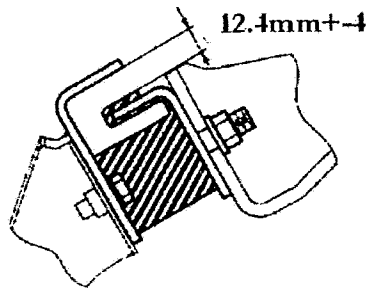

Right

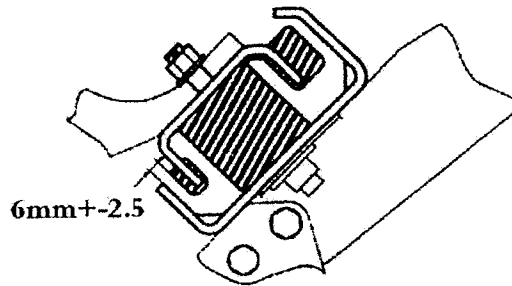

Left

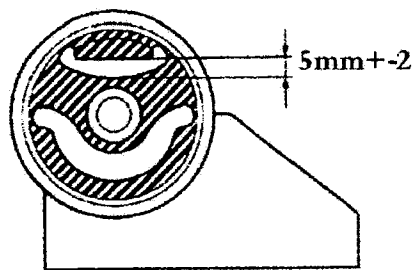

Center Mount

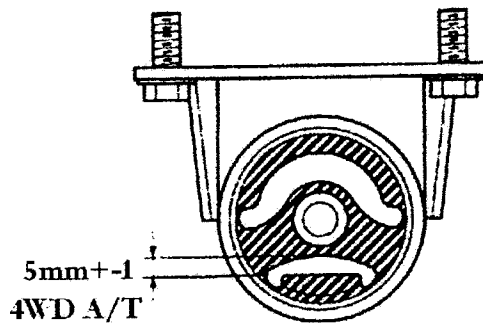

Rear Mount

Engine

Engine Exploded View Component Diagram

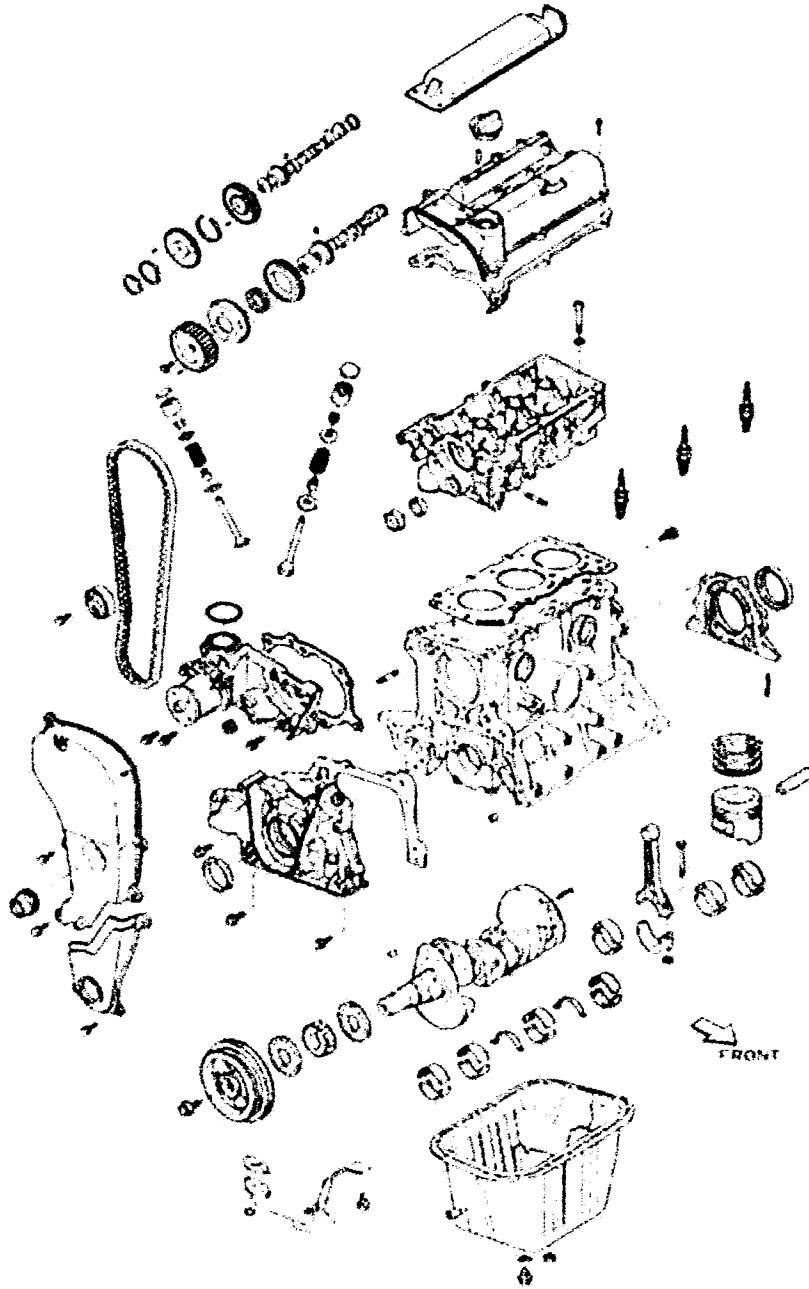

660cc Engine



Engine

Diagnostic Connectors

Diagnostic Connectors

Picture	Part Number	Use
	09991-87604-000 Harness Test Connector	Pickup Truck RPM Adapter
	09991-87705-000 Engine Control Harness Test Adapter Connection	Engine Circuit Testing

Engine Condition:
Before performing engine work it is important to check oil condition. Oil is the best indicator to the internal condition of the engine.

Dirty oil will impede engine performance and can cause premature engine failure.

Oil Filter maximum use: 10,000 Kilometers

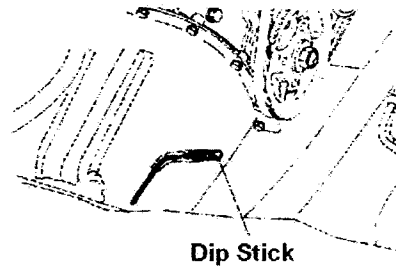

Dip Stick

Engine Series	EF-NS, EF-ES	EF-TS
SAE	5W-30	10W-30
API	SE	SF
Capacity	3.1 Liters	3.1 Liters
Oil Change	10,000K or 6mo	10,000K or 6mo

*Note: Do NOT use heavier grade oils. Heavier oils can increase pressure and cause gasket failure

Fuel Hose & Vacuum Hose:

Rubber fuel hoses must be changed maximum every 4 years

Do not re-use fuel hoses if removed once

Engine

Engine Exploded View Component Diagram

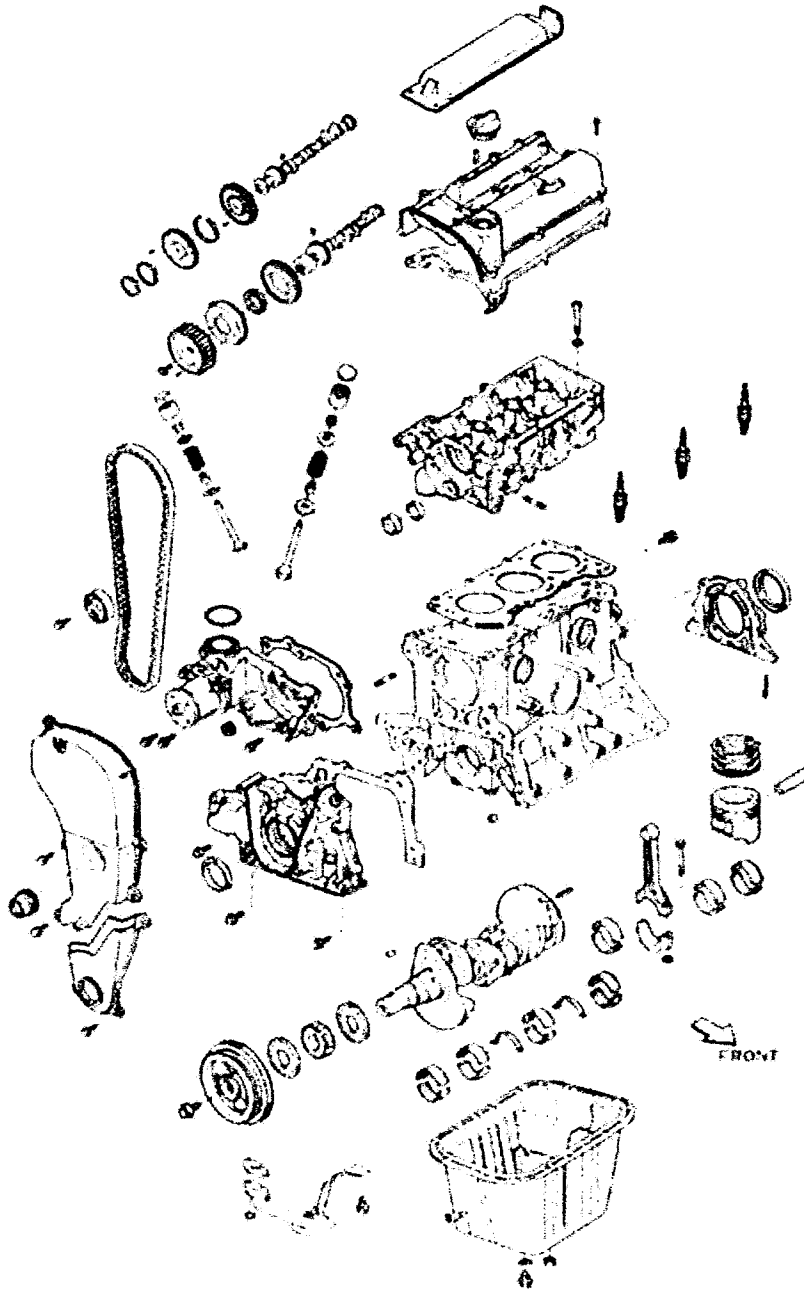

660cc Engine



Engine

Diagnostic Connectors

Diagnostic Connectors

Picture	Part Number	Use
	09991-87604-000 Harness Test Connector	Pickup Truck RPM Adapter
	09991-87705-000 Engine Control Harness Test Adapter Connection	Engine Circuit Testing

Engine Condition:

Before performing engine work it is important to check oil condition. Oil is the best indicator to the internal condition of the engine.

Dirty oil will impede engine performance and can cause premature engine failure.

Oil Filter maximum use: 10,000 Kilometers

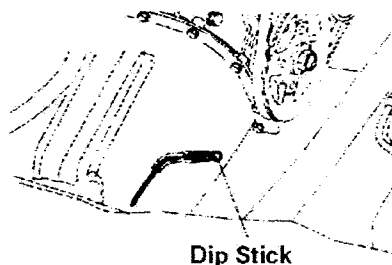

Dip Stick

Engine Series	EF-NS, EF-ES	EF-TS
SAE	5W-30	10W-30
API	SE	SF
Capacity	3.1 Liters	3.1 Liters
Oil Change	10,000K or 6mo	10,000K or 6mo

*Note: Do NOT use heavier grade oils. Heavier oils can increase pressure and cause gasket failure

Fuel Hose & Vacuum Hose:

Rubber fuel hoses must be changed maximum every 4 years

Do not re-use fuel hoses if removed once

Engine

Timing Settings

Use a timing Light to set timing

EF-ES

BTDC 5+-2/850 RPM

EF-TS

BTDC 10+-2/900 RPM

Note: Turn Distributor Slowly to Adjust timing.

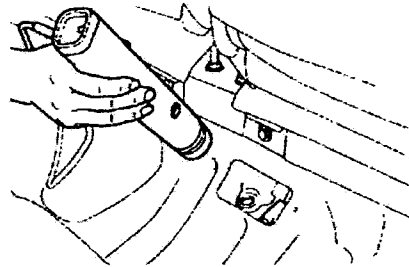

Idle Settings

EF-NS 950+-50 RPM

EF-ES 850+-50 RPM

EF-TS 900+-50 RPM

EF-NS Series

Use the diagrams to the right for Truck and Van Location Information on Vacuum Hose Nipple
If equipped with vacuum motor remove hose cover

Truck

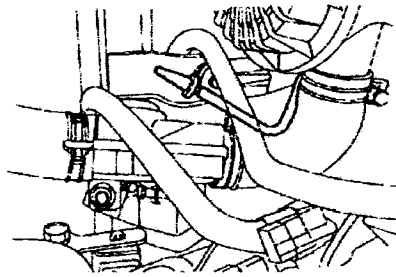

Van

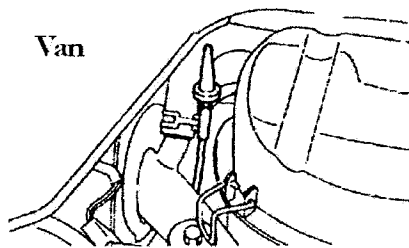

Engines not equipped with an RPM Gage
use RPM gage SST Pn# 09991-87604-000

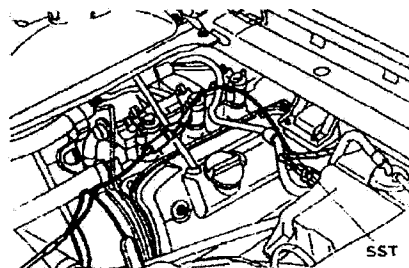

Engine

Timing Belt System Components

(B)=Bolt
(N)=Nut
(W)=Washer

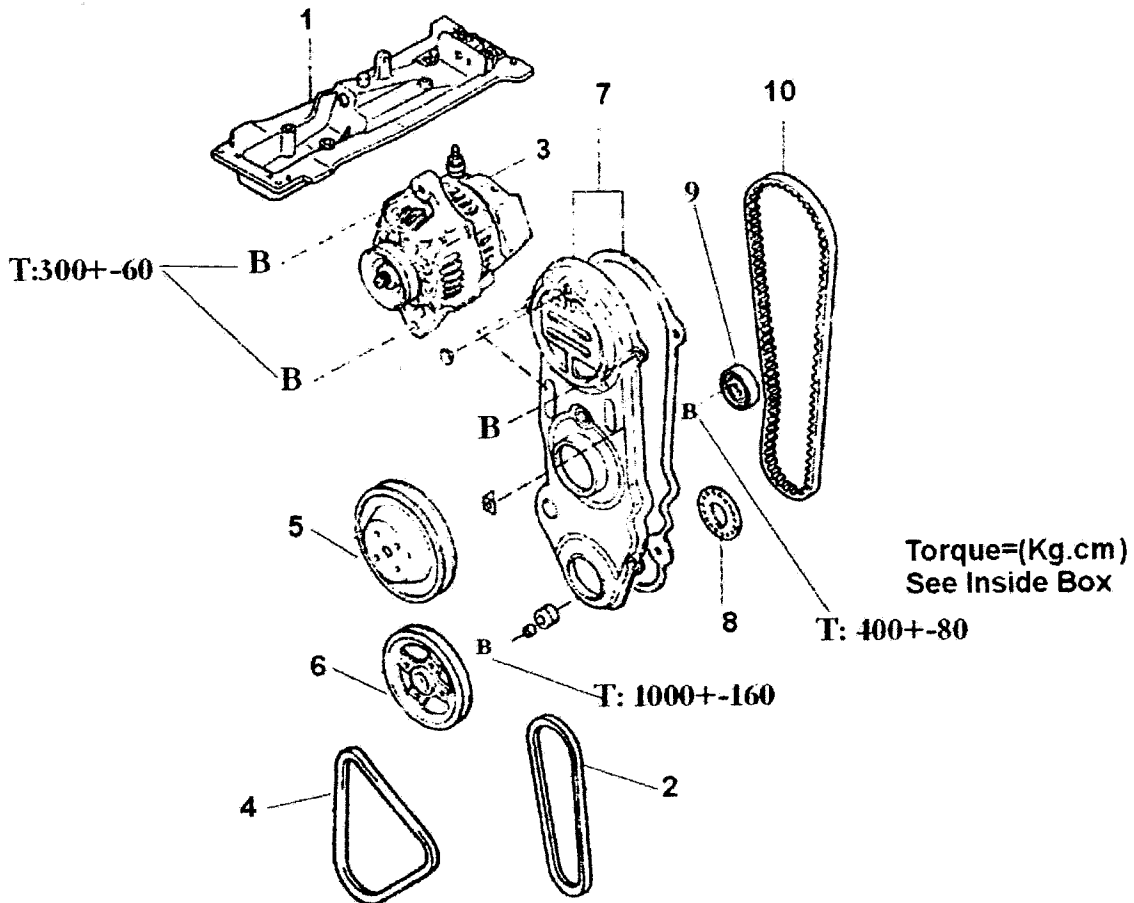

-
1. Center Member (Side Brake Member)
 2. V- Belt AC Option Vehicle
 3. Alternator
 4. V-Belt (Alternator)
 5. Water Pump Pulley
 6. Crankshaft Pulley
 7. Timing Belt Cover
 8. Flange, Crankshaft Timing Pulley
 9. Tensioner (Timing Belt)
 10. Belt (Timing)

Engine

Timing Belt Replacement

1. Jack up the Front of the Vehicle Using Proper Jack Stands described in the Front of the Book
2. Remove the (-) Battery Connection
3. Remove Inner Seat Belts Retaining Bolts
4. Remove Shift Knob, Consol (If Equiped)
5. Remove Parking Brake Lever Assembly, Transfer Shift Lever (4WD)
6. Remove Center Member (Panel Side Brake Attaches to)
7. Remove Engine Under Cover (Splash Guard) (VAN)
8. EF-NS-EF-TS Series: VSV (AC Fast Idle) Disconnect Hose.
9. (AC Vehicle) Loosen AC Compressor Attachment Bolts and Remove V-Belt.
10. Loosen Alternator Attachment Bolts, Remove V-Belt

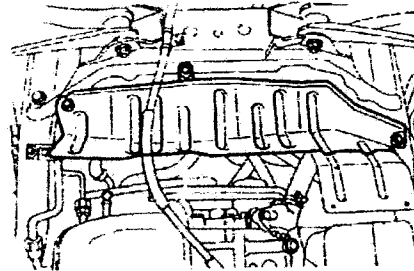

11. Use a Screw Driver as in the Diagram to the Right to Hold the Water Pump Pulley While Loosening the Water Pump Pulley Attachment Bolts

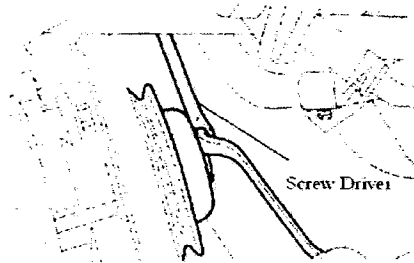

12. Remove Timing Mark Cover and Useing a Long Screw Driver, put it Threw Sevice Hole #2. Wedge it into the Ring Gear to Prevent Movement. Remove Crankshaft Pulley.
13. Remove Timing Belt Cover & Gasket. Do Not Re-Use Gasket.
14. Remove Timing Belt Pulley Flange

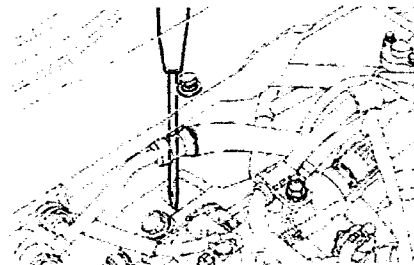

15. Rotate Engine To TDC
 - (1) See If "F" Mark is Properly Lined Up with the Aliegnment Mark. If it is "OFF MARK" This Belt Has Slipped. James Note: Tensioner has Failed and must be Replaced. A New Belt Could Cuase an Old Tensioner to Fail Quickly.
 - (2) Look For Broken Teeth of Rubber that has Fallen into Cover.

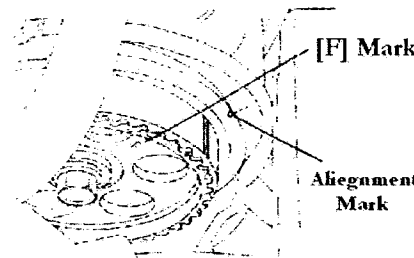

James Note: If the Vehicle has over 100,000 Kilometers and has a slipped Belt Replace All Parts. Its Not Worth doing it All Over Again.

Note #2: Beware of Cheap Replacement Parts that DO NOT Have an (F) Mark! Always Buy Correct OEM Parts

Engine

16. Loosen and remove timing belt Tensioner

17. Remove timing belt

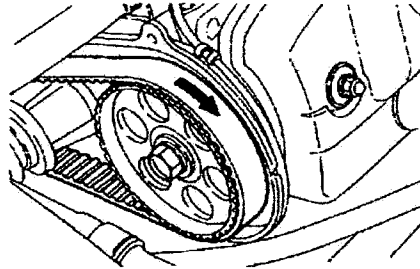

Use the chart below to check belt condition

Note: This will help you determine engine running condition.

Belt Conditions

Belt Cracking

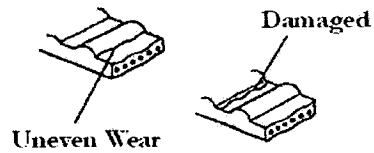

Lobe Split



Missing Lobe



Belt Separation



Note: Never re-use a timing belt. Used belts will fail if a new tensioner has been installed

Engine

Timing Belt Tensioner

Timing Belt Tensioner Inspection

Rotate timing belt tensioner and check movement. Any resistance or gritty particles can and will cause problems when a new belt is installed.

Note: Replace tensioner if over 100K

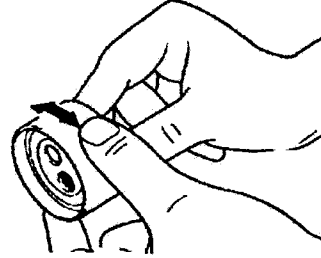

Timing Belt Pulleys

Check pulleys for wear and or missing teeth. If a lobe shows wear replace.

Note: Always replace pulleys in a set

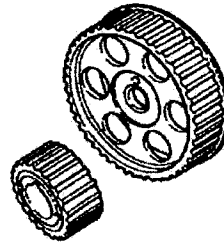

Timing Belt Layout Configuration

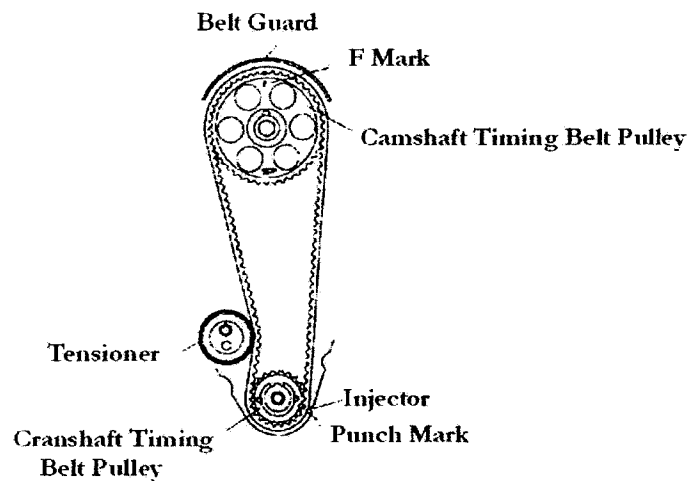

Engine

Timing Belt Assembly

Install New Timing Belt

Attach Tensioner

Utilize a M6 Bolt and thread through Access Hole
Bolt Length Should Be 20-30mm

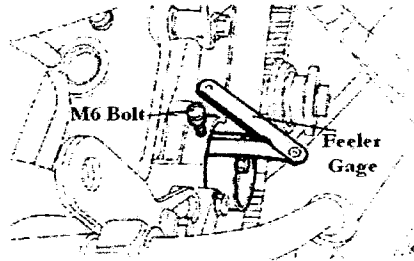

Use the Diagram on the Right as an Example

There must be 11~13mm of Clearance Between
The Tensioner and Oil Pump Body

Once the Belt is Tight & Clearance Checked
Torque Tensioner to: 400+-80 KG.CM

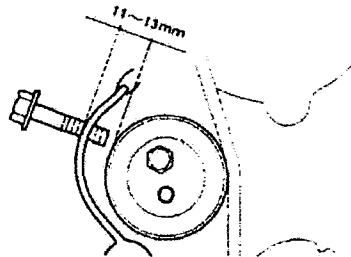

Make Sure Crankshaft Pulley Flange Matches
Diagram on the Right

Key UP as in Previous Diagram

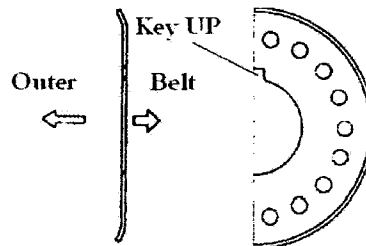

Complete Installation of Dissembled Parts
& Components in Reverse Order

Use a Long Screw Driver to Hold Puley in Place
and Torque Crankshaft Pulley to: 1000+-100KG.CM

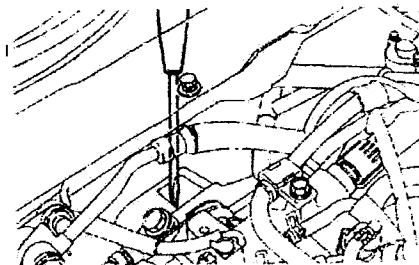

Use Screw Drive To Prop While Tightning Water
Pump Pulley Bolts

*Make Sure All Fluids Have Been Filled to Proper
Level Before Stating Engine*

Start Engine and Check Timing

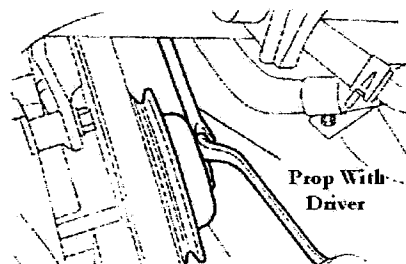

Engine

Timing Belt Parts

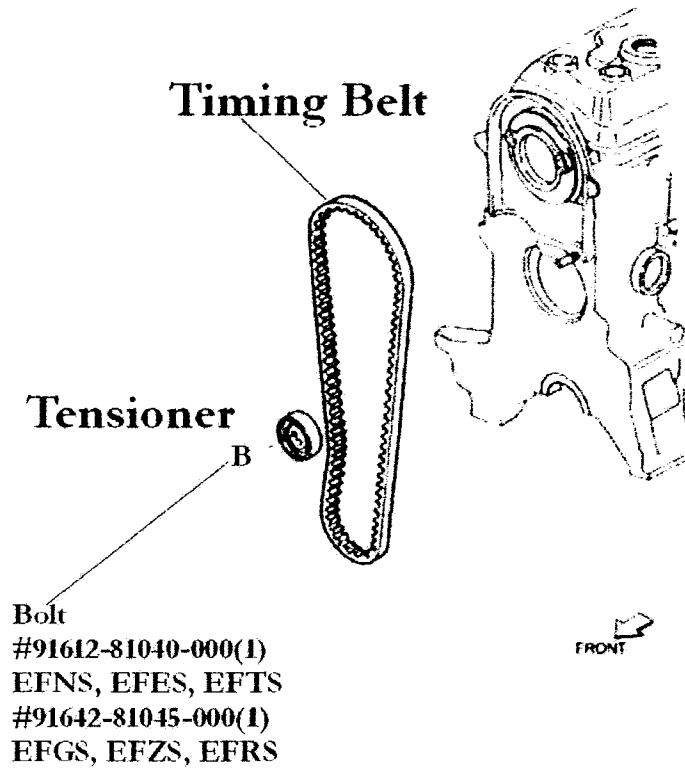

Timing Belt Part Numbers

EF-NS, EF-ES, EF-TS Part # 13514-87282-000
EF-ES Part #13514-87283-000
EF-GS, EF-ZS, EF-RS Part#13514-87215-000
EF-NS, EF-ES, EF-TS Part#13514-87283-000

Tensioner Part Numbers

EF-NS, EF-ES, EF-TS Part# 13505-87205-000
EF-GS, EF-ZS, EF-RS Part# 13505-87206-000

Engine

Head Gasket

T:=Torque Kg.Cm
*=1: EF-NS, EF-TS
*=2: EF-ES

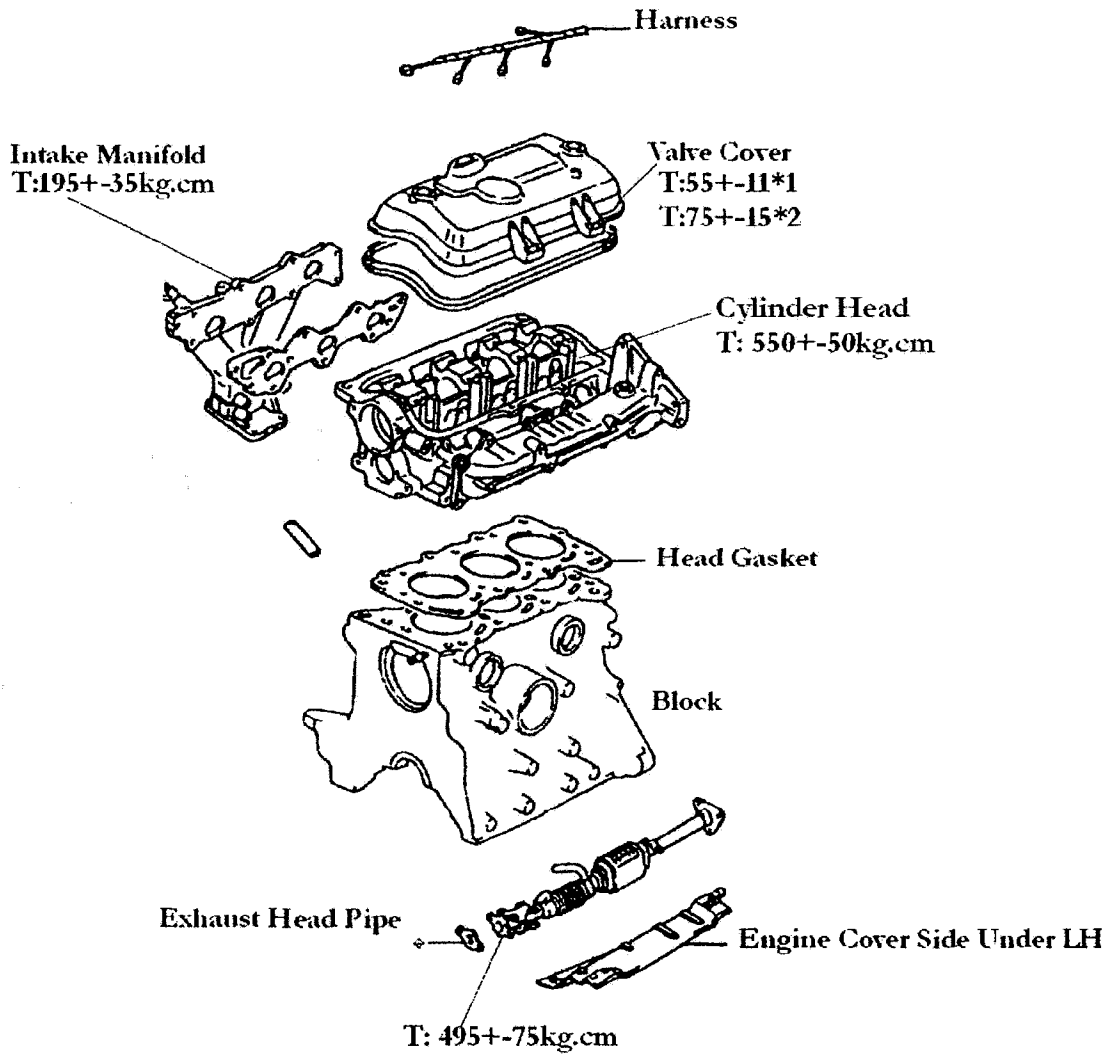

Note: Gaskets Can not be Re-Used

Note: Head Gasket Must Never Contact Oil Before Installed

Engine

Head Gasket Removal & Replace

1. Jack Up Front of Vehicle
2. Drain Coolant System
3. Release Fuel Pressure
 - (1) EF-NS Series
Open Fuel Tank Cap
 - (2) EF-ES & EF-TS
 - (1) IG Switch to [OFF]
 - (2) Remove Fuel Pump Relay
 - (3) Crank Engine Until Fuel Runs Out
 - (4) Turn Ignition Switch to [OFF]

Caution: Fuel Lines are Under High Pressure
Always Use Caution

Fuel Pump Relay (Truck)

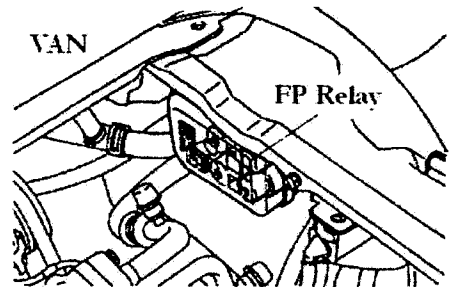
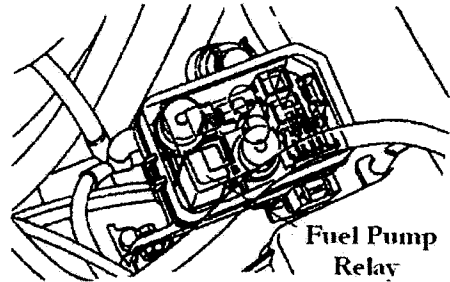

Removal

1. Remove Timing Belt (See Previous Section)
2. Remove Air-Cleaner Hose
3. Disconnect Accelerator Cable
4. Disconnect Engine Main Harness
5. Disconnect Fuel Hose Line
6. Disconnect Vacuum Lines
7. Disconnect Water Hose
8. Fuel Pump and EGR Valve (EF-NS)

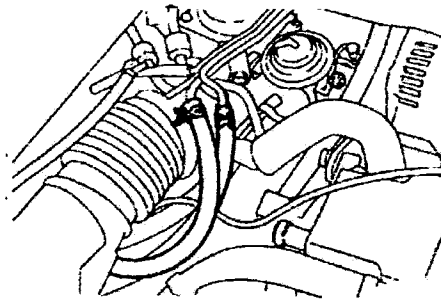

Engine

Head Gasket Continued

9. Remove Intake Manifold Assembly

Note: Gaskets May NOT be Reused

10. Remove Engine Side Under Cover LH
Disconnect Front Exhaust Head Pipe
(If Turbo-Charged Remove TB Assembly)

11. Disconnect Vacuum Hose from Distributor

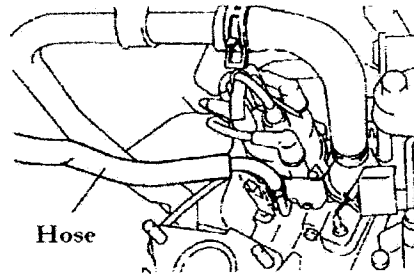
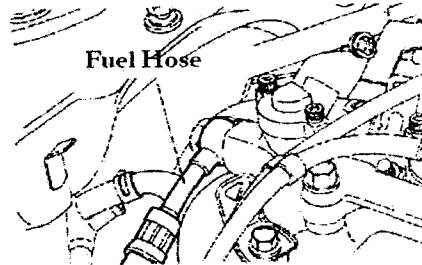

12. Remove Valve Cover Assembly
13. Remove All Remaining Attachment Bolts
14. Carefully Remove Cylinder Head

Note: Discard All Used Gaskets

15. Place Cylinder Head on a Bench For Cleaning
and Inspection

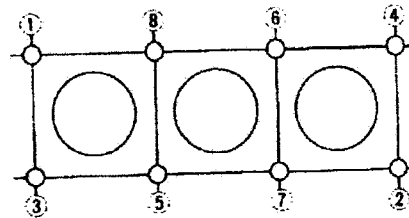

Bolt Pattern

Head Gasket Part Number

EF-ES #11115-87215-000
E-GS, EF-ZS #11115-87217-000
EF-NS, EF-TS #11115-87210-000
All Others # 11115-87219-000

Valve Cover Gasket Part Number(s)

EF-ES #11213-87208-000
EF-NS, EF-TS #11213-87206-000
All Others # 11213-87211-000

Note: Clean All Surfaces Thoroughly
Check for Surface Cracks or Other
visible Damage. If Cracks are Located
replace with New Parts. Cylinder Heads
Can Not Be Repaired.

Engine

Cylinder Head Gasket Assembly

Torque Sequence

1. Place New Gasket On Clean Block Surface
2. Place Head And Start Head Bolts to Snug
3. Torque Head Bolts To: 550+-50(Kg.Cm)
Use Diagram on Right For Torque Sequence

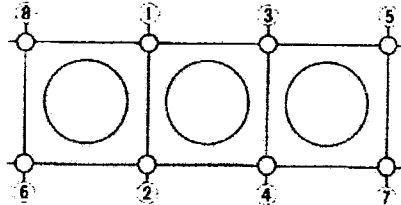

4. Attach Cylinder Head Valve Cover
Torque to: EF-NS & EF-TS
55+-11(KG.CM)
EF-ES
75+-15(KG.CM)
5. Attach Distributor Hose & Connections
6. Turbo-Charged Engines: Attach Assembly
7. Attach Exhaust
Torque: 495+-75(KG.CM)
8. Attach Engine Side Under Cover
9. Attach New Gasket for Intake Manifold
and Torque Intake Manifold to:
195+-39(KG.CM)
10. EF-ES & EF-TS Attach Fuel Line
11. EF-NS EGR Valve
Torque 195+-39(KG.CM)
Fuel Pump Assembly
Torque: 195+-39(KG.CM)
12. Attach Water Hose
13. Attach Water Outlet Bypass Pipe
14. Re-Attach Vacuum Lines

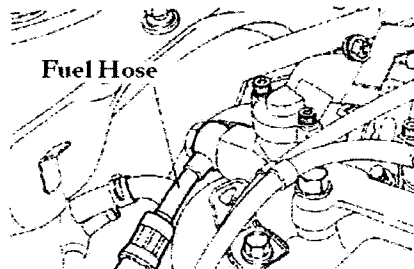
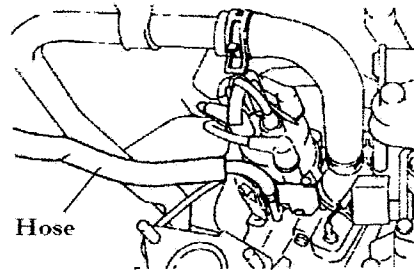

Engine

15. Attach Fuel Hose
16. Attach Engine Harness
17. Attach Accelerator Cable
Engagement Free Play
1 to 4mm
18. Attach Air Cleaner Hose
19. Assemble Timing Belt
(See Previous Chapter)
20. Add Coolant
21. Change Engine Oil & Filter
22. Start Engine and Check Timing

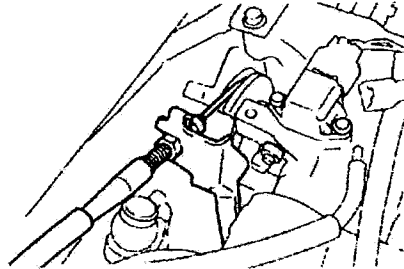

Accelerator Cable

Engine

Head & Valve Cover Gaskets

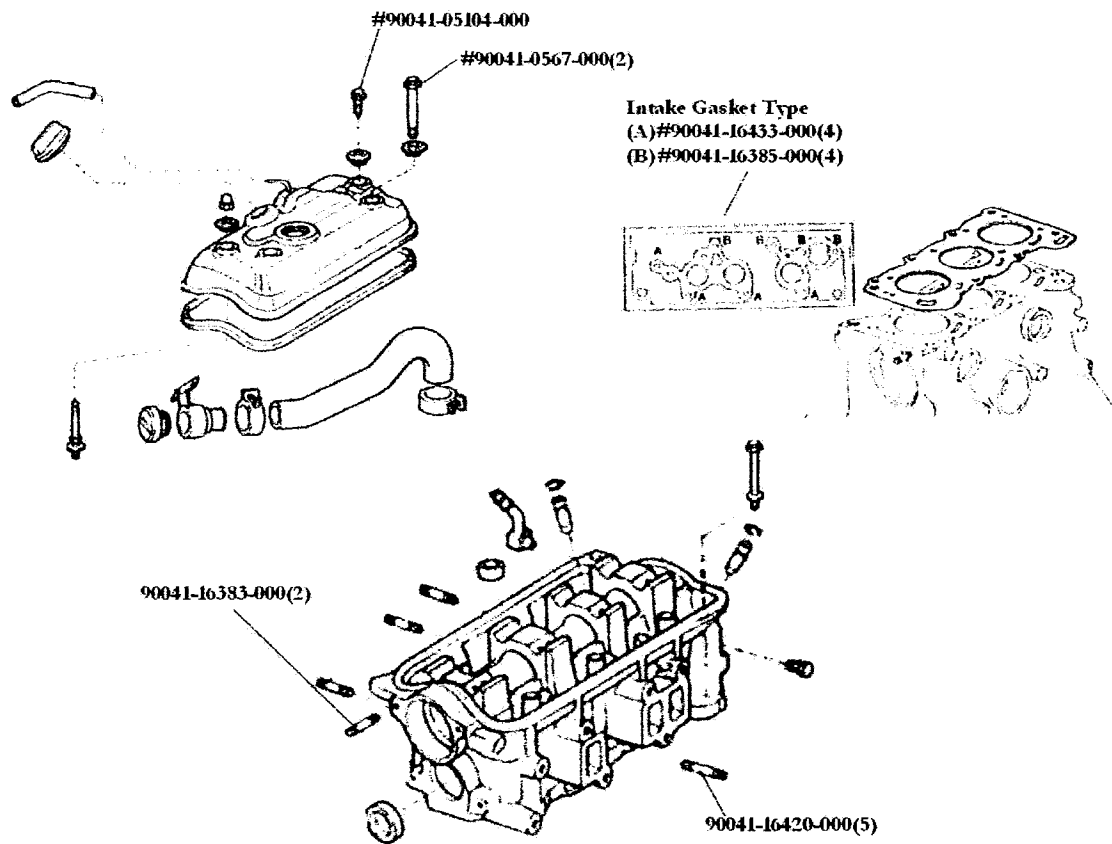

Parts (ALL Series)

Head Gasket

EFES S100,S110, S120, S130 #11115-87215-000
EFGS-EFZS S100, S110, S120, S130, PS4 #11115-87219-000
EFNS-EFTS S100, S110, S120, S130 #11115-87210-000
All Others #11115-87219-000

Valve Cover Gasket

EFES S100, S110, S120, 130 #11213-87208-000
EFNS-EFTS (All) #11213-87206-000
EFGS-EFZS-EFRS (All) #11213-87211-000

Engine

Valve Train Stem & Oil Seal Parts

EFGS-EFZS-EFRS Shown

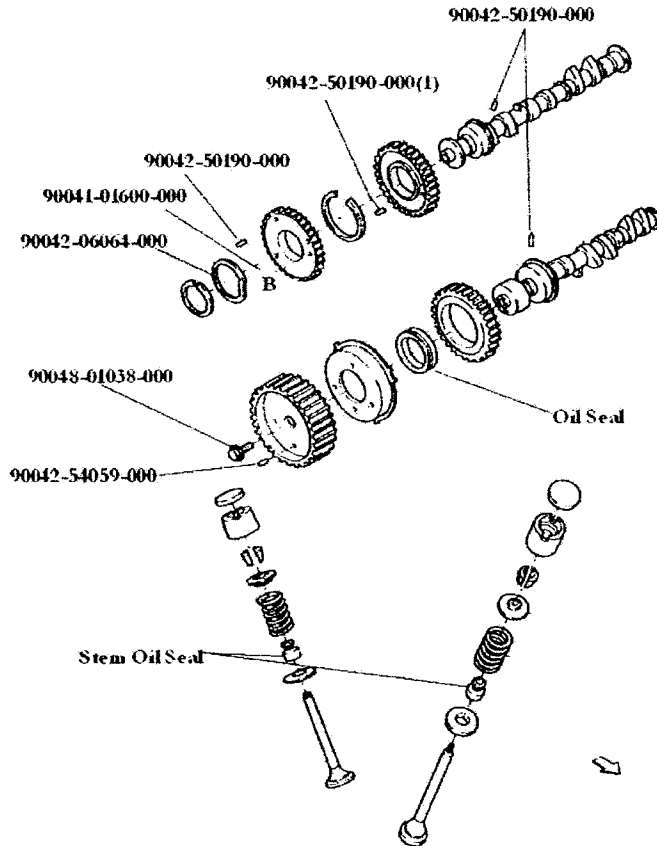

Valve Stem Seal

EF-ES	Part# 90048-12015-000
EF-NS, EF-TS	Part#90048-12009-000
EF-GS, EF-ZS, EF-RS	Part#90048-12021-000

Seal Type "T" (All EF Series)

Part # 90043-11277-000

Engine

Oil Pump System

SST=Special Service Tool

Special Service Tools

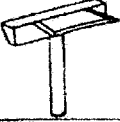
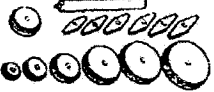
	Picture of Tool	Part Number Part Name	Use
S S T		09032-00100-000 Gasket Scraper	Oil Pan Gasket Removal
		09608-87302-000 Seal Set (Drive)	Oil Seal Replacement

B=Bolt

N=Nut

T: =Torque kg.cm

Diagram

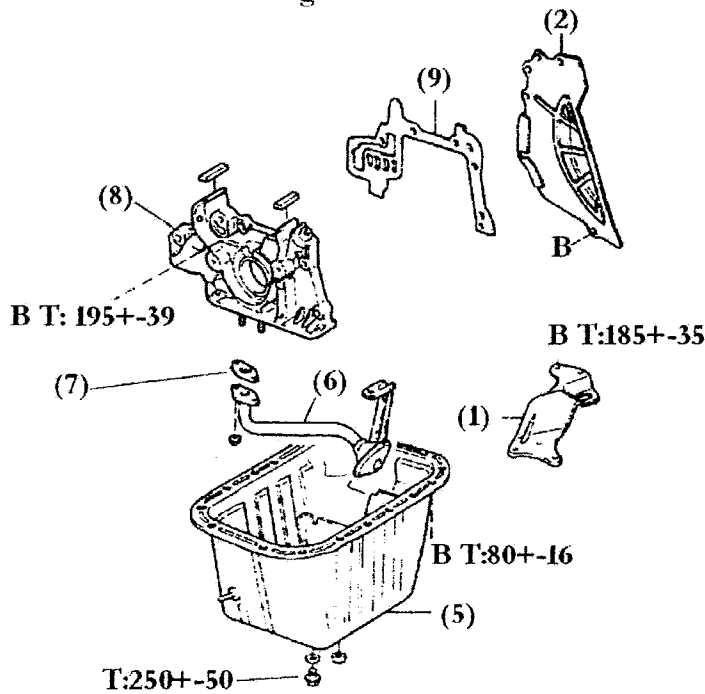

1. Power Train Brakcet
2. Clutch Housing Cover
5. Oil Pan
6. Oil Strainer
7. Oil Strainer Gasket
8. Oil Pump Assembly
9. Oil Pump Gasket

Note: Item 3&4 are note listed in this diagram

Engine

Oil Pump Replacement

Pre-Steps

A. Drain Oil

B. Remove timing Belt (Previous Section)

1. Remove Power Train Braket
(See Diagram on the Right)

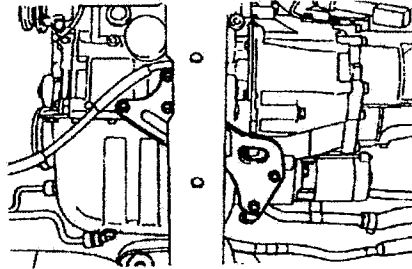

2. Remove Clutch Housing Cover Plate

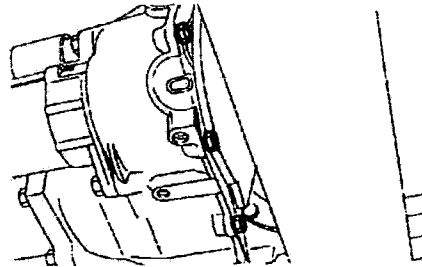

3. (AC Equiped Vehicles) Disconnect
Compressor & Move Harness to the
Side for Clearence

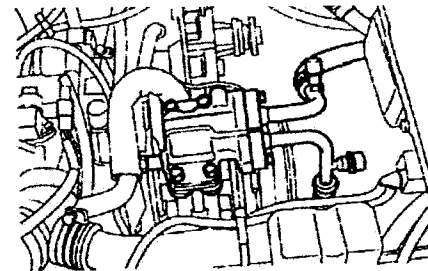

4. (AC Equiped) Remove Compressor Braket

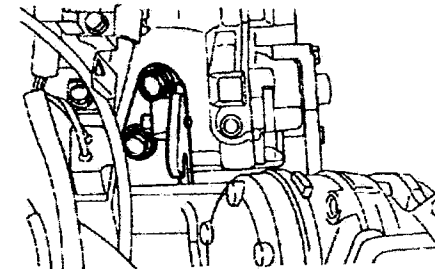

Engine

Oil Pump Replacement

5. Remove Oil Pan Bolts

Note: Use Service Tool To Separate Pan

SST 09032-00100-000

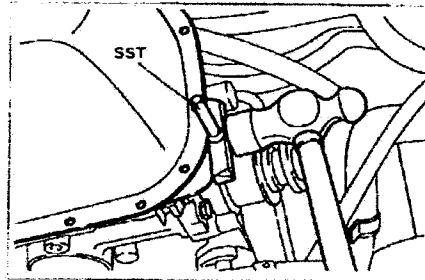

6. Remove Oil Pan

Note: Due to Clearance on Some models it
Maybe Nessesary to Unbolt Strainer
Attachment Bolts and Strainer to
Remove Pan.

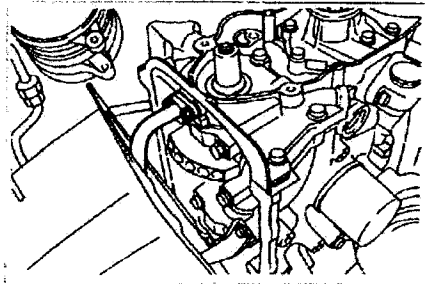

7. If Pan was Removed With Strainer
Still Attached Remove Now. Scrap
Off Old Gasket.

Note: Never Re-use Gaskets

EF Series Gasket PN: 15149-87203-000

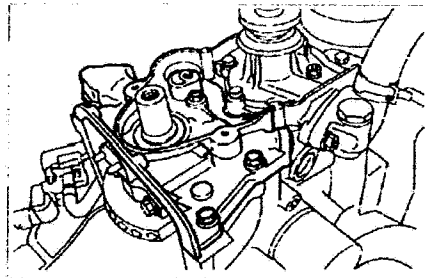

8. Remove Pump

Note: Clean All Surfaces & Remove any
Foreign Debris

9. Attach New Pump Assembly
Torque to: 200+40(kg.cm)

10. Attach Strainer

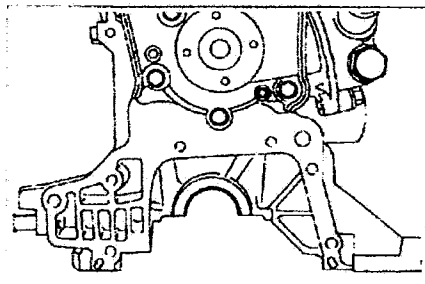

Note: If Planning to Rebuild Pump Please
Read Next Chapter

Engine

Oil Pump Installation

1. Note: Thoroughly Clean Surfaces

James Note: I Recommend Copper Plus RTV
Blue RTV WILL Leak

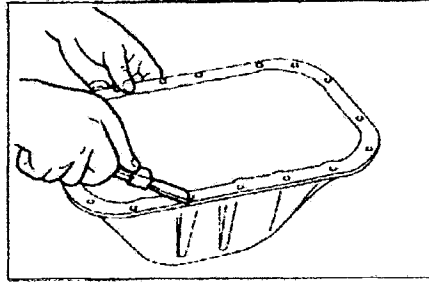

2. Put a Bead of Copper Plus High Temp RTV
Along The Edges and let Stand 5-10 Minutes

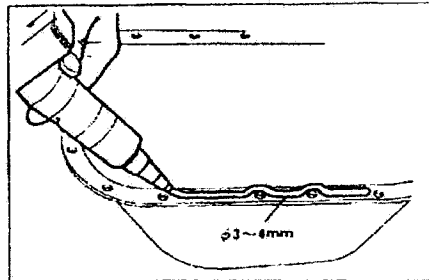

3. Slide Pan on & Take Care Not to Let Gasket
Slip
Torque Pan Bolts to: 70+-5(kg.cm)

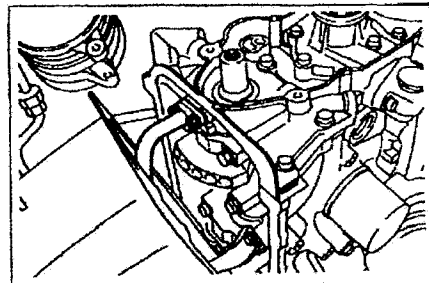

4. Attach Brackets AC Vehicles
Compressor Bracket Torque
620+-120(kg.cm)

Attach AC Compressor/Hoses/Harness

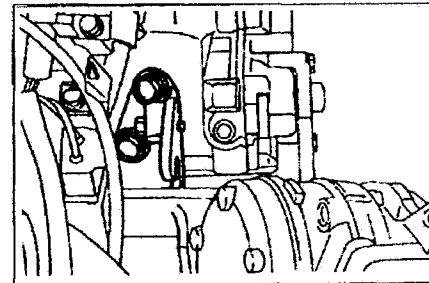

5. Install Clutch Hosing Cover Plate

6. Attach Power Train Braket

Torque to: 185+-35(kg.cm)

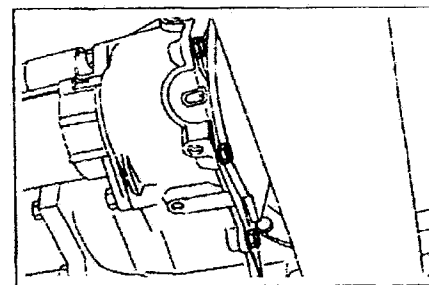

7. Attach Timing Belt and Other Belts

8. Change Oil Element & Add New Oil

Engine

Oil Pump Component Diagram

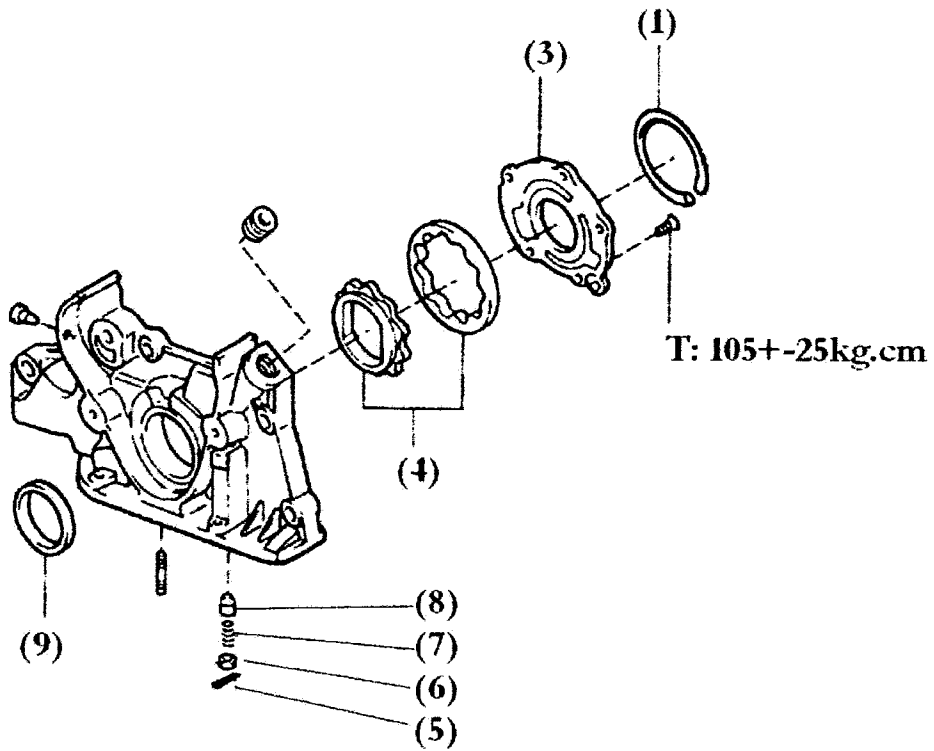

1. Ring "O"
2. Attachment Screw
3. Cover, Oil Pump
4. Gear, Oil Pump Drive
5. Cotter Pin
6. Oil Pump Relief Retainer
7. Valve Compression Spring
8. Valve Oil Pump Relief
9. Seal, Type "T" Oil

Engine

Oil Pump Overhaul

1. Remove "O" Ring
2. Remove Screws
3. Remove Oil Pump Cover
4. Remove Oil Pump Drive Gear

Note: If trouble Removing Screws Tap
Lightly With Hammer & Driver
Do Not Hit Hard

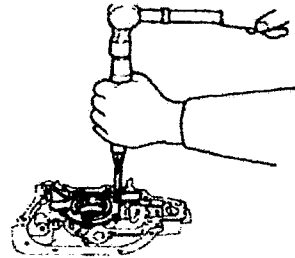

5. Remove Cotter Pin

Note: Do Not Re-Use Cotter Pin

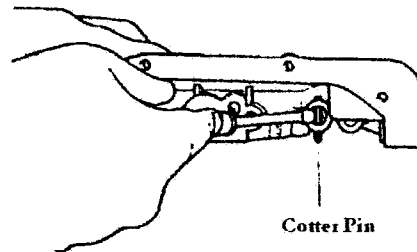

6. Remove Inner Parts. Relief Spring
Relief Valve & Retainer

Inspect: Check for Damage or Cracks
Clean Thoroughly



Valve



Spring



Retainer

7. Use a Driver & Remove Seal

Caution: Do Not Use Excessive Force

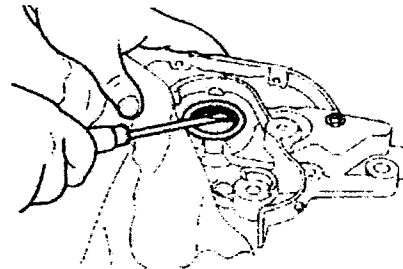

Engine

Oil Pump Overhaul

1. Check Oil Pump Drive Gears

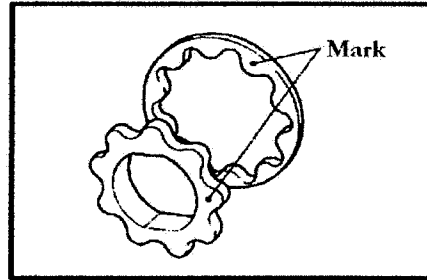

2. Clearance Check: Check 9 Lobes

Acceptable: 0.17mm to 0.24mm
Replace: 0.35mm

Note: Make Sure Clearance Checked
with Clean Gears. (Grease Free)

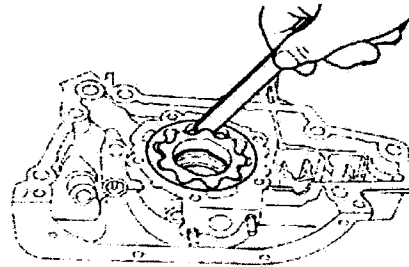

3. Body Clearance (Between Rotor and Body) See Diagram to the Right

Acceptable: 0.10mm to 0.185mm
Replace: 0.25mm

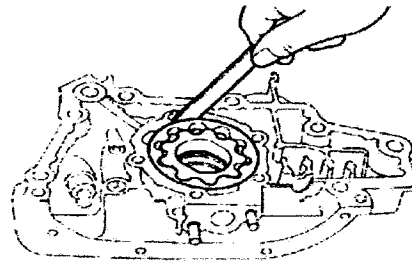

4. Lightly Lubricate With Grease



5. Lubricate Seal With Clean Engine Oil

Assemble Oil Pump

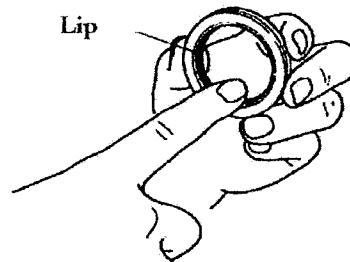

Engine

Oil Pump Overhaul

6. After Assembling Relief Valve Spring and Retainer Install New Cotter Pin

7. Install Pump

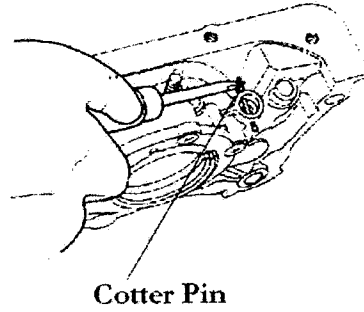

Engine

Oil Pump Parts

Oil Pump

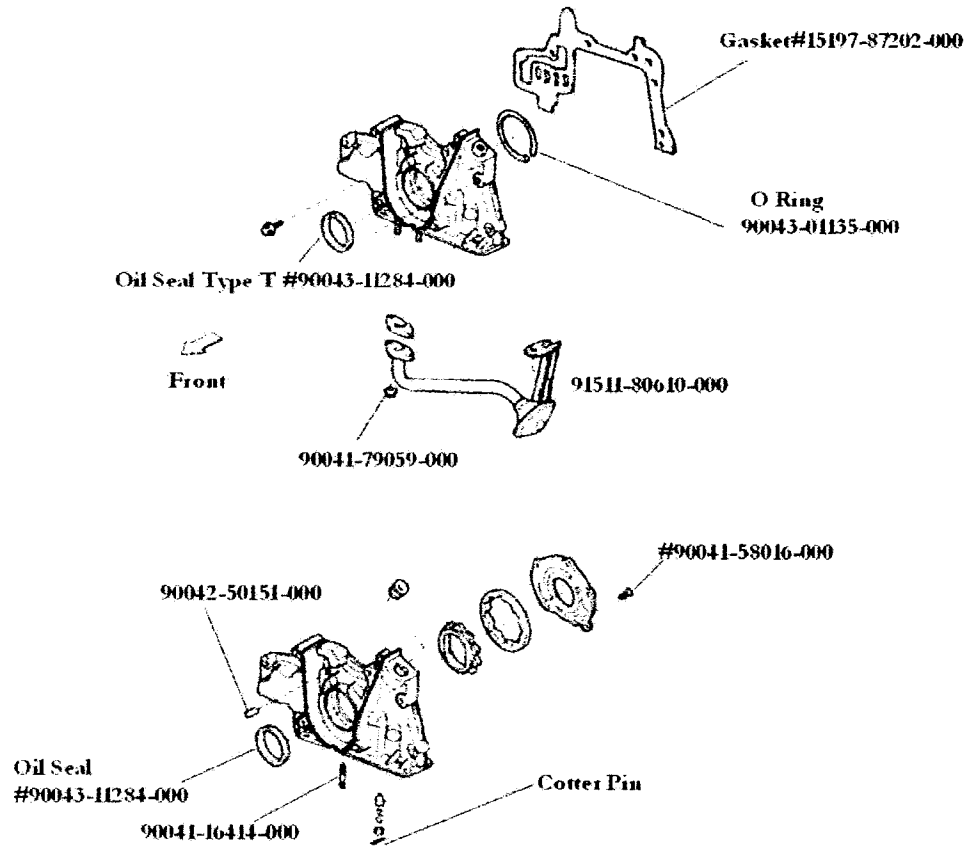

Note: At This Time Only Part Listed Above Are Available At Dealer Level

Engine

Oil Filter

Oil Filter

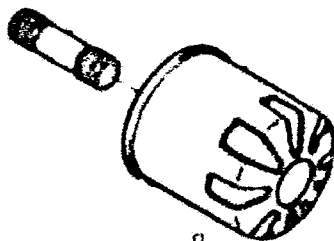

Denso
Tokyo Roki

Oil Filter Part#

EF Series S100-S110-S120-S130

PN: 15601-87204-000 or PN: 15601-87703-000



Cross Reference to:

Suzuki Part #16510-81403

Mazda Part #AY01-14-300A

Engine

Pistons & Block

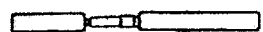
	Picture	Part Number	Use
s		09032-00100-000	Gasket Scraper
s		09221-87206-000	Piston Pin Remover Stand
r		09221-87207-000	Piston Pin Remover Bar

Torque=Kg.cm

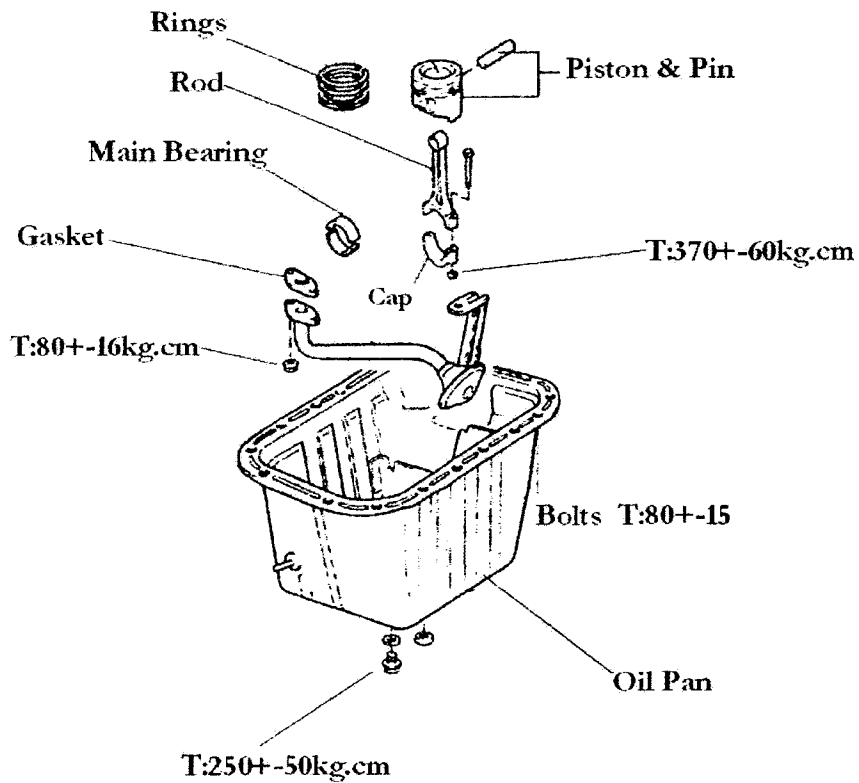

Engine

Pistons & Block

1. Remove Piston Rings with Pliers

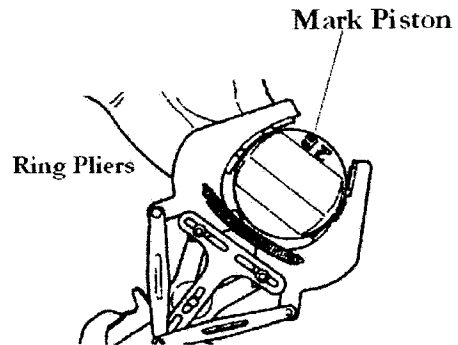

2. If Piston Pins are to be Removed Use Special Service Tools Listed Above

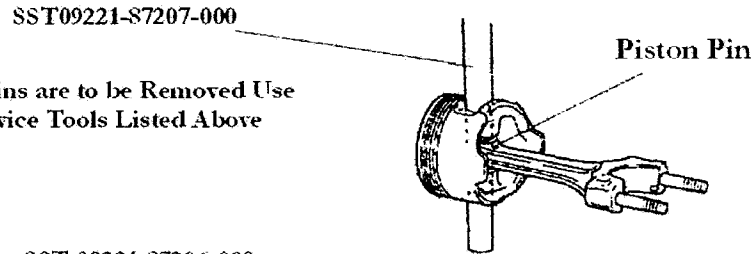

3. Remove Piston Pins and Clean Thoroughly

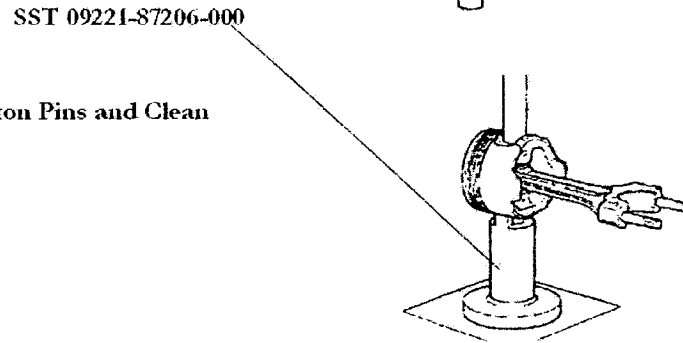

Cylinders

1. Using The Diagram Measure The Cylinder Roundness Minimum 6 Positions

Limits: Between 68.00mm to 68.03mm

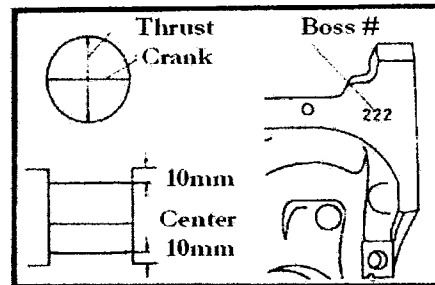

Engine

Pistons & Block

2. Use a Cylinder Gage & Check Points

A-B and a-b

Taper Degree Maximum = 0.03mm

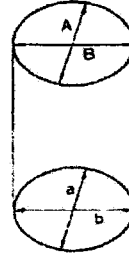

3. Clean out Piston Grooves Using an Old Ring or Use Ring Groove Cleaner Tool

Note: Do Not Re-Use Old Rings
Note: Do Not Use Wire Brush

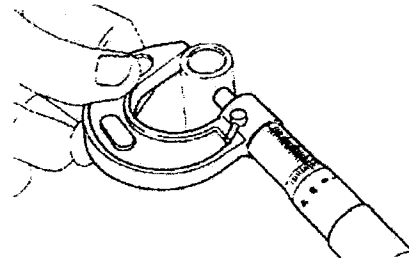
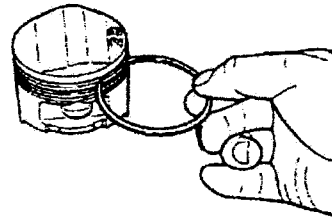

4. Piston Pin Clearance

Limit: 0.005mm~0.011

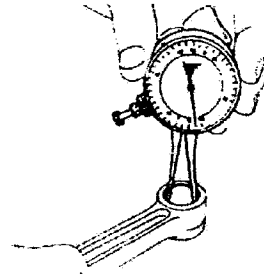

5. Piston Measurement

Limit= 67.965~67.995

Note: Measure From 11.5mm Down
as in the Diagram on the Right

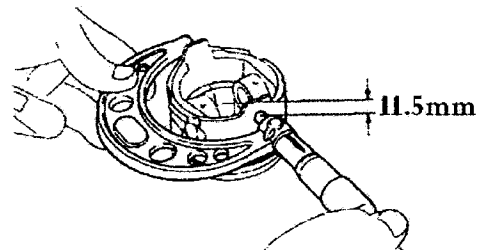

Engine

Pistons & Block

Cylinder & Piston Oil Clearance Check:

Clearance: 0.025mm~0.045mm
 Limit: 0.10mm

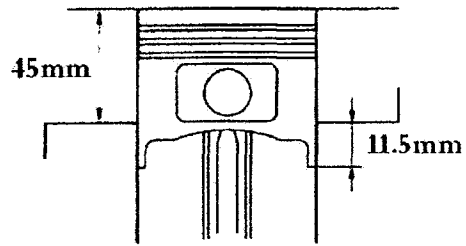

Front

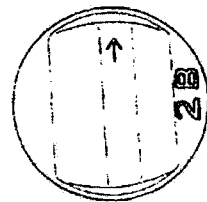

Piston Mark

EF-NS & EF-ES

	Cylinder (Inner)	Piston (Outer)
1	68.00mm~68.010mm	67.965mm~67.975mm
2	68.010mm~67.020mm	67.965mm~67.985mm
3	68.020mm~68.030mm	67.995mm~67.995mm

EF-TS

	Cylinder (Inner)	Piston (Outer)
1	68.00mm to 68.010mm	67.955mm to 67.965mm
2	68.010mm ~68.020mm	67.965mm~67.975mm
3	68.020mm~68.030mm	67.975mm~67.985mm

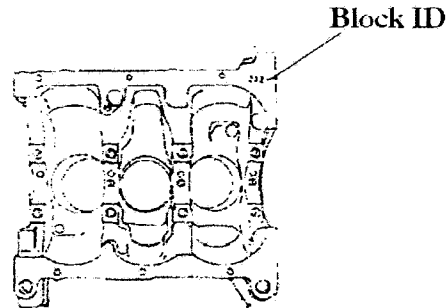

Block ID

Piston Ring Side-Clearance

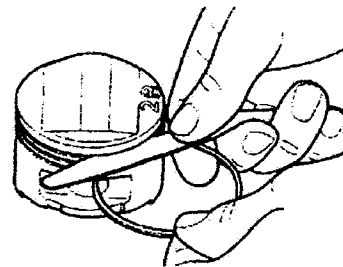

EF-NS & EF-ES

	Clearence	Limit
No 1	0.03 ~ 0.07	0.12
No 2	0.02 ~ 0.06	0.11

EF-TS

	Clearence	Limit
No 1	0.045 ~ 0.095	0.12
No 2	0.015 ~ 0.065	0.11

Engine

Pistons & Block

Piston Ring Block Test

Push Piston Ring 45mm Down Into Bore
Take The Following Measurements

	Clearance	Limit	
		EFNS-ES	EFTS
No. 1	0.25~0.40	0.65	0.55
No. 2	0.40~0.55		
Oil	0.2~0.7	1.0	
	0.2~0.5		

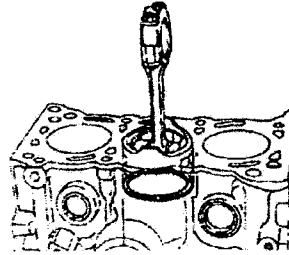

Use a Thickness Gage as Pictured in the Diagram

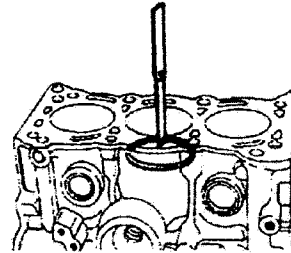

End Cap [Bearing]

Connecting Rod Bearing Clearance

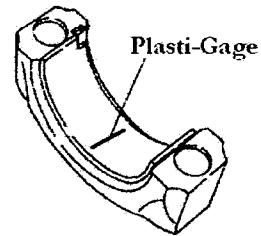

Use a Plastigage to Check Clearance

Clearance: 0.020mm~0.044mm

Limit: 0.07mm

Cap Bearing Torque: 370+/-60 (kg.cm)

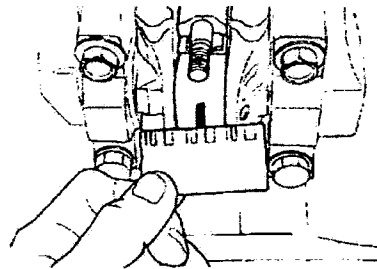

Engine

Pistons & Block

Engine Front Markings

Use the Diagram on the Right for Location Markings

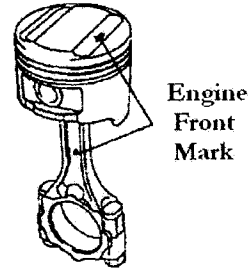

Use The Special Support Tools For The Following

- SST** 09221-87206-000Ⓐ
- 09221-87207-000Ⓑ

Using the SST Tools Install Piston Pins

Caution: Extream Pressure Required
Wear Saftey Goggles and
Protective Wear

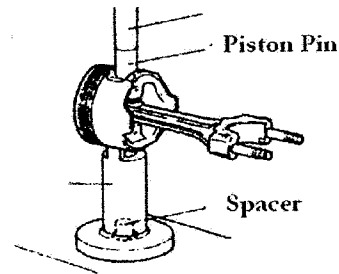
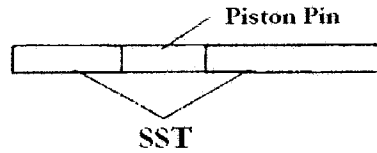

Piston Ring End Gap Face Diagram
Note: Slight Differences Per Maker

	Face
No. 1	
No. 2	

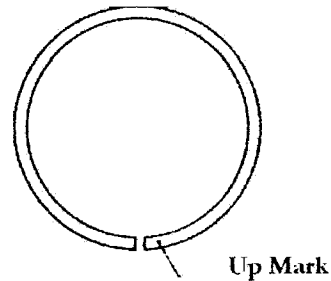

Engine

Pistons & Block

Ring Installation:
No.1 & No.2 Rings Must
be 180 Degrees Opposite. Front Rear
Direction

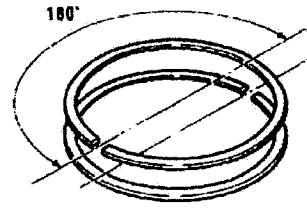

Connecting Rod Installation

Place Either Vinyl Tape over the Ends
or Old Vacuum Hose to Prevent
Damage To Crankshaft

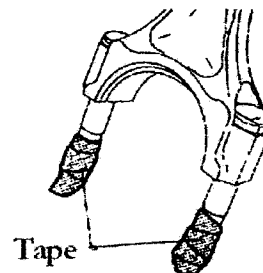

Piston Intallation

Use a Spring Compressor For Intalation.
Make Sure to Use New Engine Oil to
Coat the Cylinder Linings and Piston
Rings. Straight 30W Oil Recommended

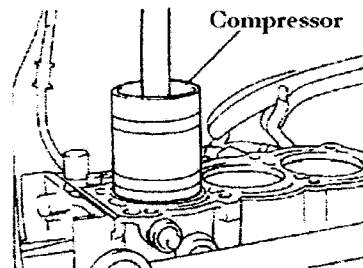

Bearing Cap Torque: 370+-60 (kg.cm)

Engine

Engine Parts

S100-S110-S120-S130

N=Made by NPR
R=Made by Riken

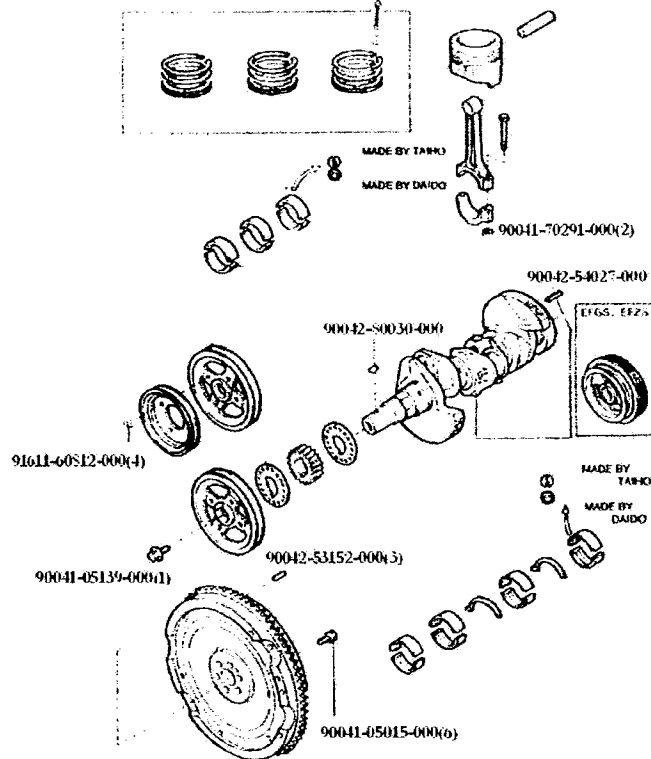

All EF Series S100-S110-S120-S130

Washer Set: Crankshaft Thrust

- Part# 11011-87201-000 (STD)
- Part# 11012-87201-000 (OS) 0.125mm
- Part# 11013-87201-000 (OS) 0.25mm

Bearing Set Crankshaft

- Part# 11702-87206-000 (STD) Taiho Maker
- Part# 11702-87207-000 (STD) Daido Maker
- Part# 11703-87206-000 (OS) 0.25mm Taiho
- Part # 11703-87207-000 (OS) 0.25mm Daido
- Part# 11704-87206-000 (OS) 0.50mm Taiho
- Part# 11704-87207-000 (OS) 0.50mm Daido

Piston & Pin Set

- Part# 13101-87234-000 (STD)
- Part# 13102-87234-000 (OS) 0.25mm
- Part# 13103-87234-000 (OS) 0.50mm
- Part# 13104-87234-000 (OS) 0.75mm
- Part# 13105-87234-000 (OS) 1.00mm

Piston Ring Set

- Part# 13011-87218-000 (STD) Riken Maker
- Part# 13011-87219-000 (STD) NPR Maker
- Part# 13012-87218-000 (OS) 0.25mm Riken
- Part# 13012-87219-000 (OS) 0.25mm NPR
- Part# 13013-87218-000 (OS) 0.50mm Riken
- Part# 13013-87219-000 (OS) 0.50mm NPR

Connecting Rod Bearing Set

- Part# 13202-87204-000 (STD)
- Part# 13203-87204-000 (OS) 0.25mm
- Part# 13204-87204-000 (OS) 0.50mm

Engine

Miscellaneous Engine Parts

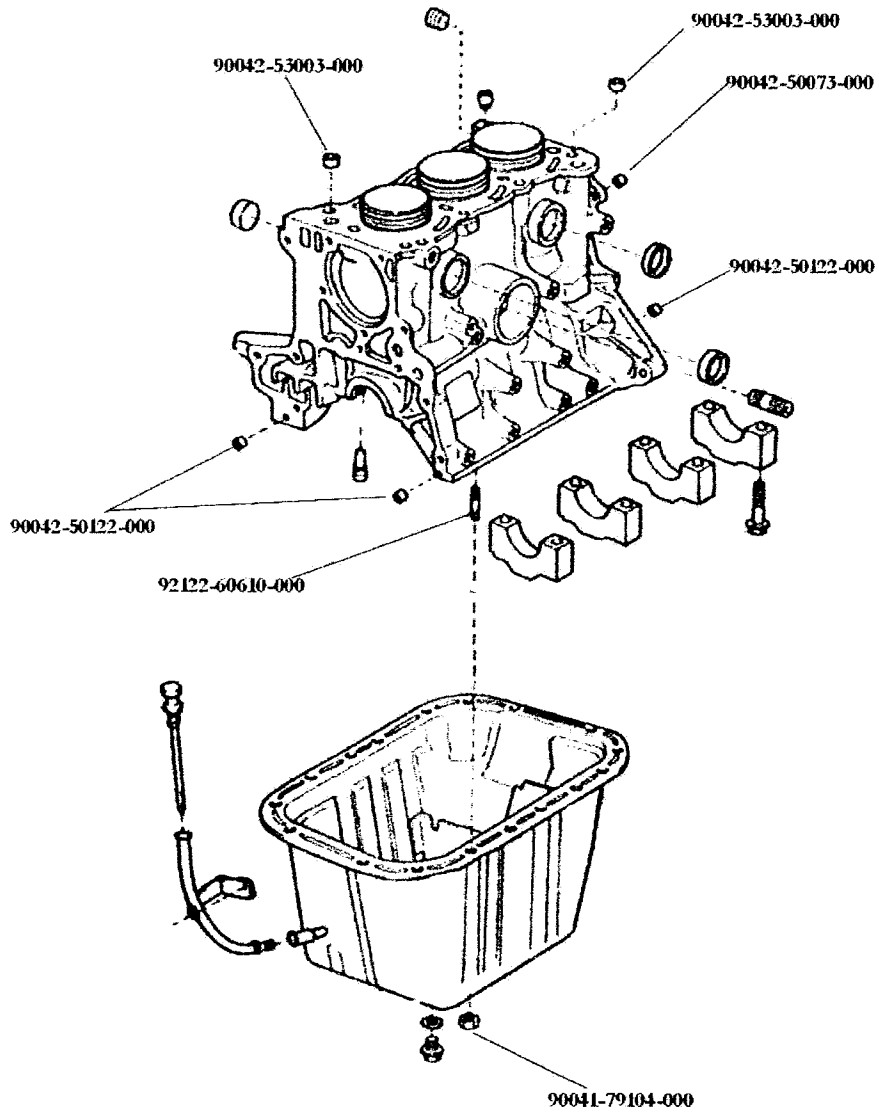

Chapter 8

Starter & Alternator

- Starter
- Starter Circuit & Specifications
- Alternator
- Charging Circuit & Specifications

Starter

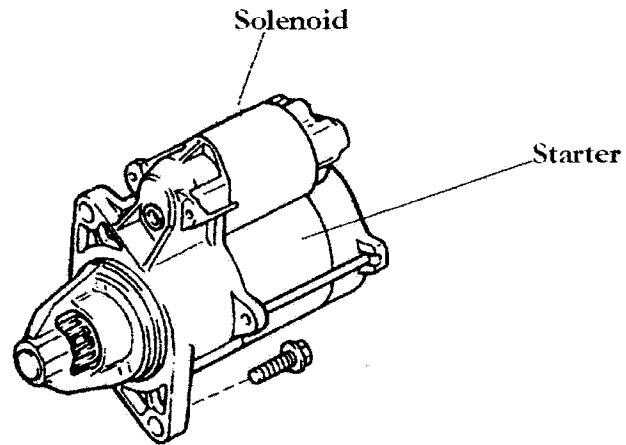

Removal

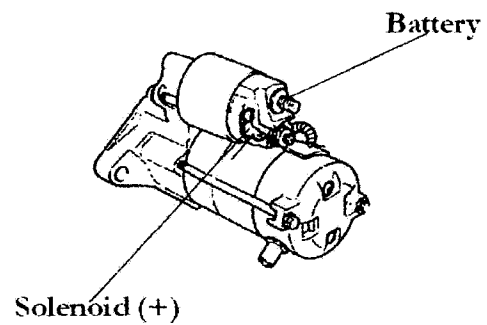

1. Jack Up Vehicle
2. Disconnect Battery (+) and (-) terminals
3. Remove Starter Attachment Bolts (2)
4. Slide Back and Remove Solenoid Terminal Connector and (+) Battery Cable Connection from Solenoid

Starter

Starter Circuit & Specifications

Circuit

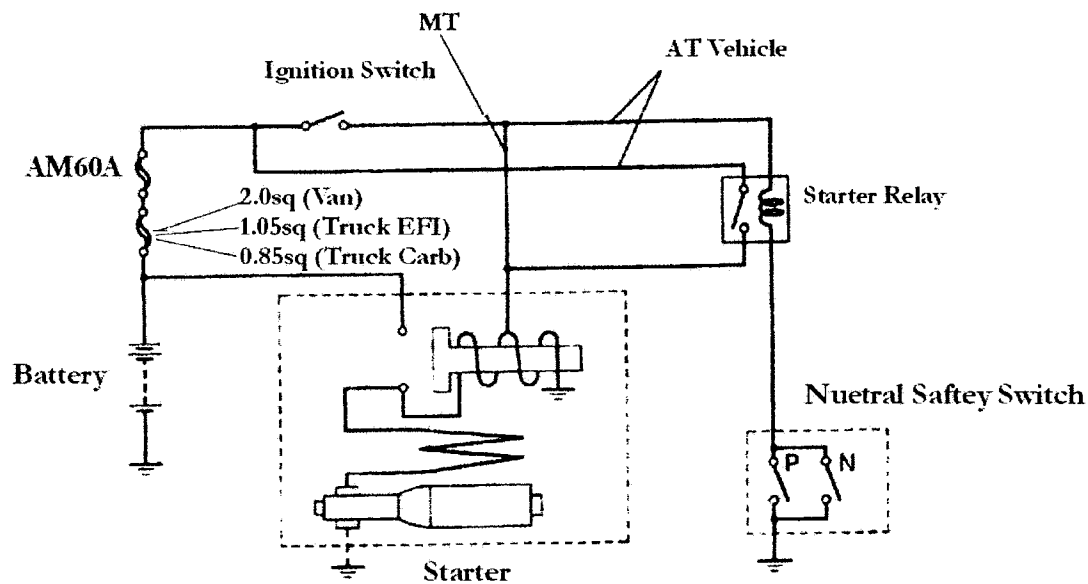

Specifications

Vehicle Type	Normal	Freezer Truck (Special Option)
Output (kw)	M/T 0.6 AT 0.7	M/T 0.8 AT 1.0
Drive Gear Teeth	M/T (9) AT (8)	M/T (9) AT (8)
Weight (kg)	M/T 3.1 AT 3.2	M/T 3.1 AT 3.2

Alternator

Alternator Components & Removal

(B)=Bolt

Torque: kg.cm

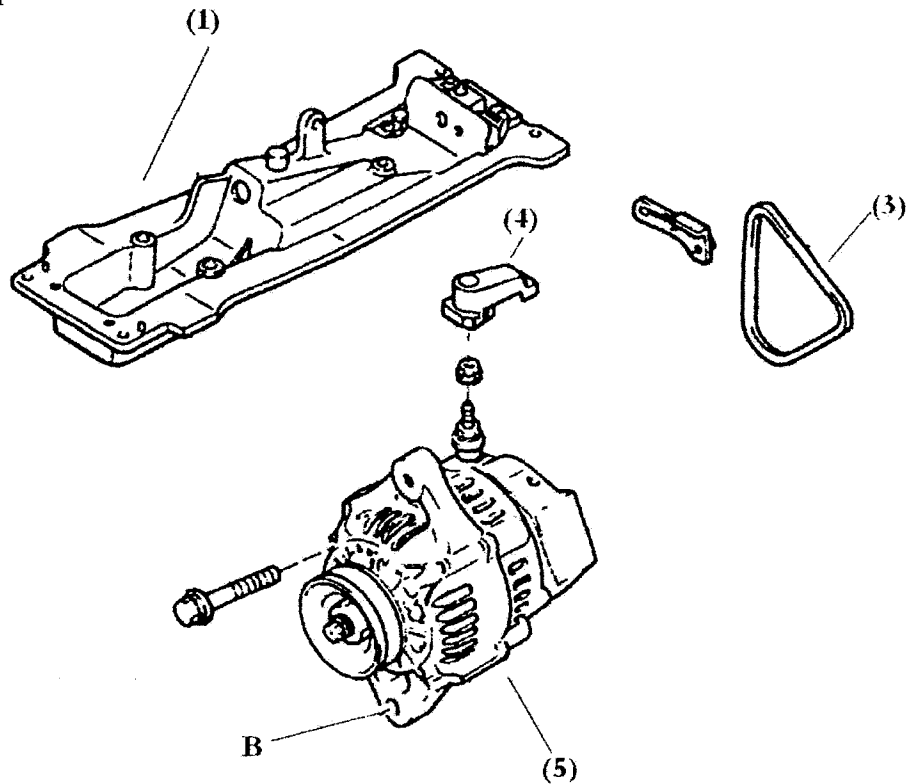

1. Seat Riser Center Assembly
2. Belt: V-Belt A/C (Not Shown)
3. Belt: V-Belt Alternator
4. Harness
5. Alternator Assembly

Removal

1. Disconnect Battery (-) and (+) Terminals
2. Remove Seat Riser Center Assembly
3. A/C Vehicles Remove A/C Belt
4. Remove Alternator V-Belt
5. Disconnect Alternator Electrical Harness
6. Remove Attachment Bolts and Remove Alternator Assembly

Alternator

Charging Circuit & Specifications

Charging Circuit

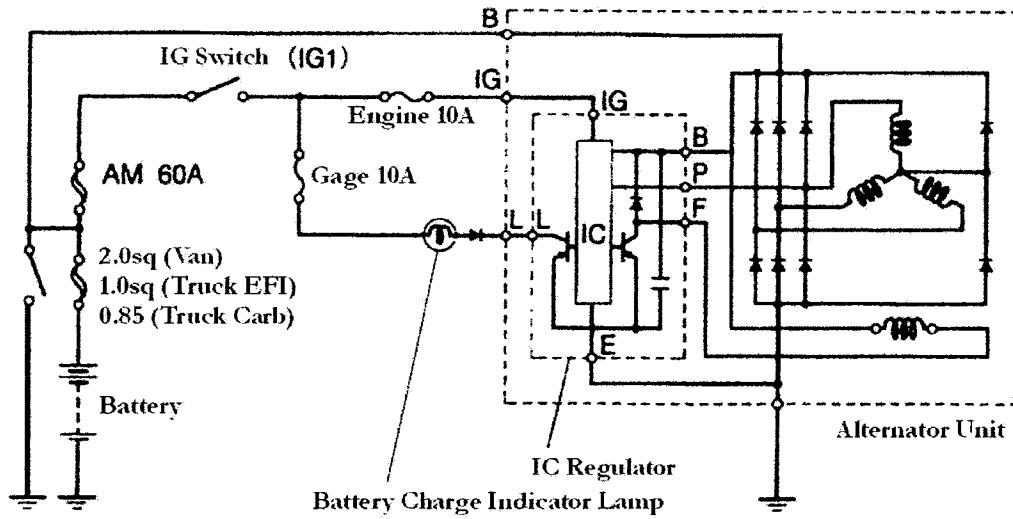

Specifications

Vehicle	Volts/Amps	Maximum RPM	Regulator Output
Truck: EFNS	12v 40A	15,000	14.2~14.8
EFES (T) & EFNS(Van)	12v 50A	15,400	13.6~14.4
EFES(T-AT) EFES (V-MT)	12v 55A	18,000	13.6~14.4
EFES (V-AT) EFTS	12v 60A	18,000	13.6~14.4

Chapter 9

Fuel System

- Carburetor Assembly
- Carburetor Removal & Replacement
- Carburetor Setting and CO HC Levels
- Carburetor Component Diagram
- Fuel Filter & Part Numbers
- Fuel Tank & Components (Truck) Base Carbureted
- Fuel Tank & Components (Van) Base Carbureted
- EFI Fuel Injection
- EFI Fuel Injection Components & Parts Location
- Engine Control Computer Connector Pin Guide
- Fuel Pump: Mechanical (Head Type), & Electric (Body or Tank)
- Fuel Lines EFNS (Truck)
- Fuel Lines: EFES
- Fuel Lines: Turbo-Vehicle
- Fuel Lines: EFNS (Van)
- Fuel Lines: EFES (Van) Fuel Injected

Fuel System

Carburetor Assembly

EF-NS Van & Truck

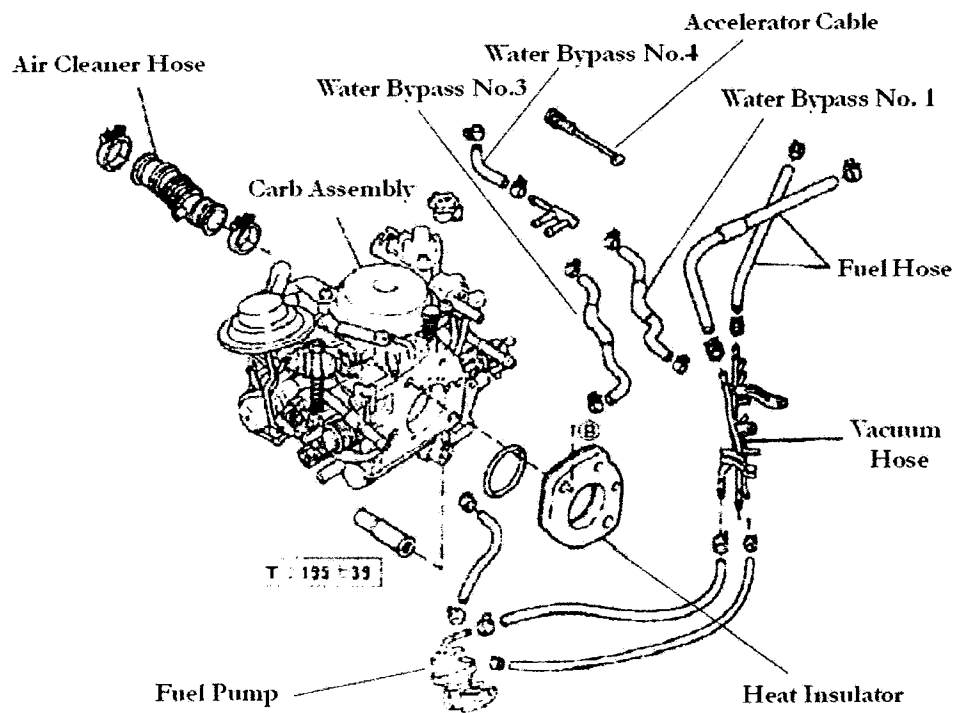

Fuel Pump Part Number
EF-NS, EF-GS S100-S110-S120
Mechanical Part# 90041-79052-000

Fuel System

Carburetor Replacement

1. Remove Front Seats and Remove Center Riser Panel (Between Seats)

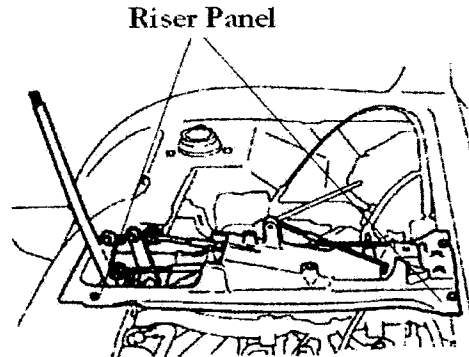

2. Disconnect Fuel Hose Line and Vacuum Connections

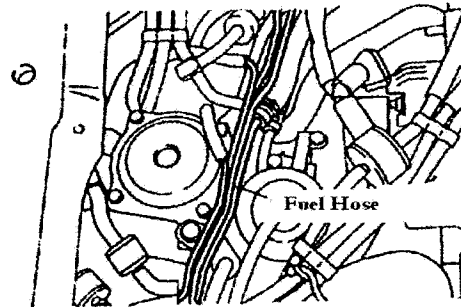

3. Disconnect Air Cleaner Duct Hose

Note: Check Duct Hose For Cracks or Holes
Replace if Damaged

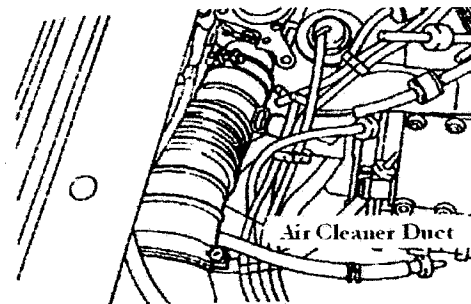

4. Carefully Disconnect Electrical Connector

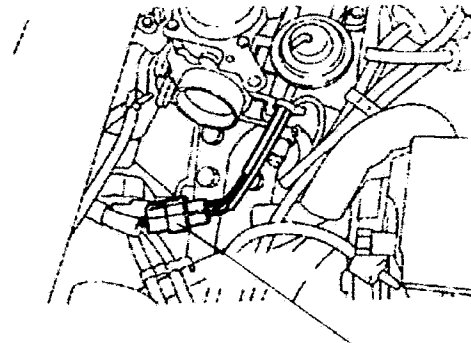

Fuel System

Carburetor Installation

4. Connect Fuel Vapor Hose

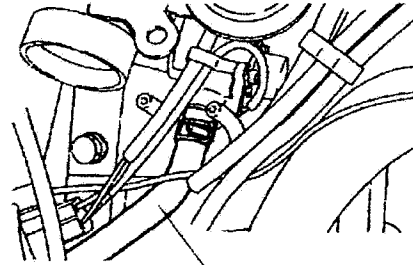

Vapor Hose

5. Attach Accelerator Cable

Note: Cable Free Play (Engagement): 1~4mm

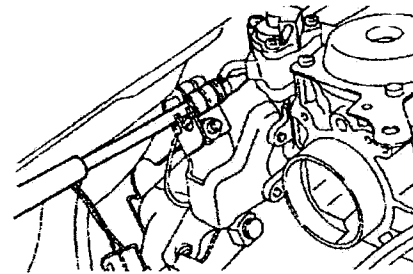

6. Attach Electrical Connector

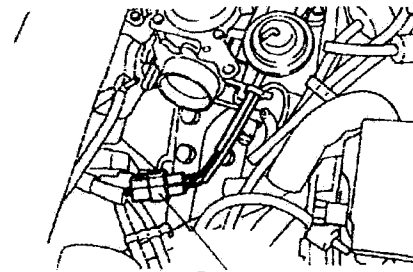

Connector

7. Attach Air Cleaner Duct Hose

8. Attach Vacuum Hoses and Fuel Line

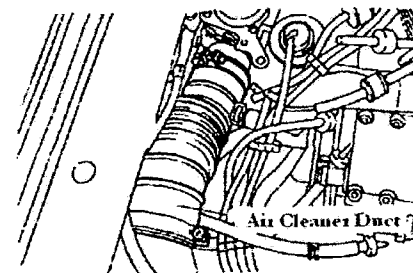

Air Cleaner Duct

9. Assemble Seat Riser Center Member

10. Assemble Remaining Components

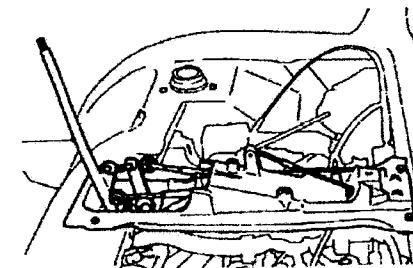

Fuel System

Carburetor Replacement

5. Disconnect Accelerator Cable From Carburetor

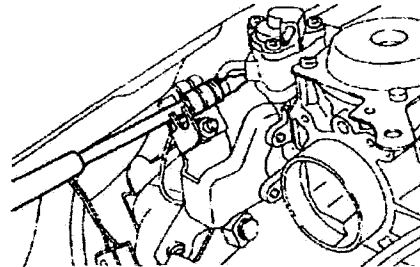

6. Disconnect Fuel Vapor Hose as in Diagram on Right

Note: Replace Hose if Cracked or Brittle

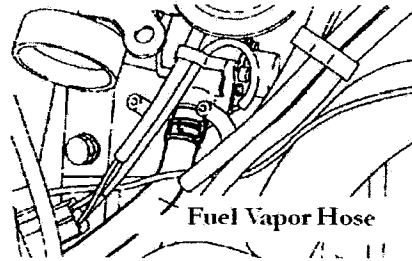

7. Disconnect The Following: Water Bypass Hoses, Mounting Bolts.
8. Remove Carburetor, Place Cover Over Intake Opening.

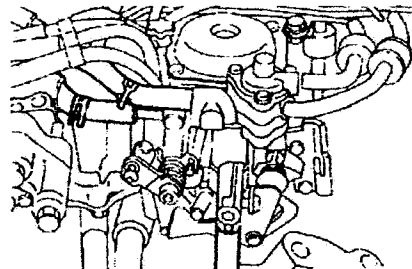

Installation

1. Clean All Surfaces

Note: Intake Manifold To Carburetor Gasket Rubber Side to Carb Side

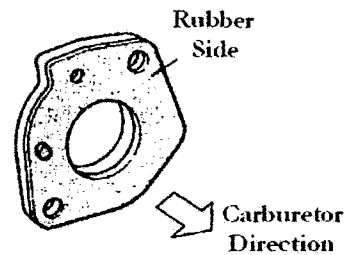

2. Attach Carburetor Assembly
Torque Lock Nuts T:195+-39kg.cm

3. Attach Water Bypass Hoses

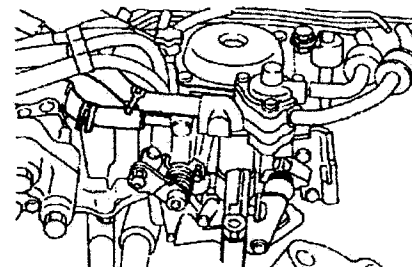

Fuel System

Carbureted Idle Adjustment & CO HC level

EF-NS

To Set Idle Adjustment The Idle Adjustment Screw Must Be Turned In Either Direction

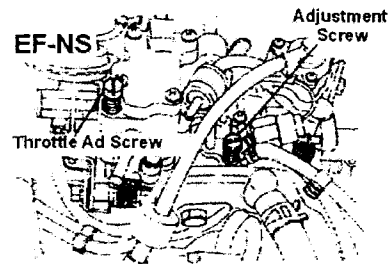

EF-ES

EF-ES Series Engines Idle System is Computer Controlled

James Note: Idle Curcuit Trouble is 99% of the Time the ISC Valve
ISC is Connected to ECU (Rotary ISC) (RSO & RSC Connection)

EF-TS

EF-TS Series

Using a SST connector Pn#09991-87604-000
attach tachometer.

Set Idle to 900+/-50 RPM

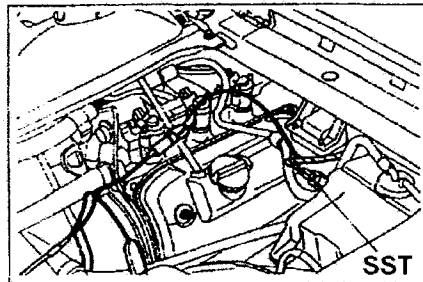

CO-HC Levels

EF-NS (Use Mixture Screw to Adjust)

Idle CO-HC Level

CO 1.5+/-1.0% to -0.5%

HC 900 PPM (Parts Per Million) or Less

EF-ES & EF-TS

Idle CO-HC Level

Co 1.5+/-1.0% to -0.5%

HC Below 900 PPM

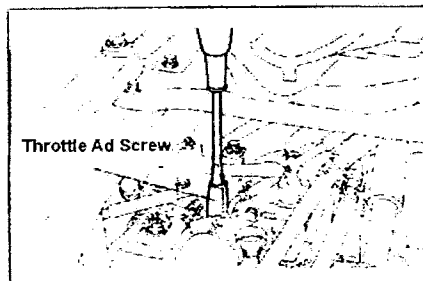

SST=Service Support Tool

Fuel System

Fuel Filter

Fuel Pump Part Number

EF-NS, EF-GS S100-S110-S120

Mechanical Part# 90041-79052-000

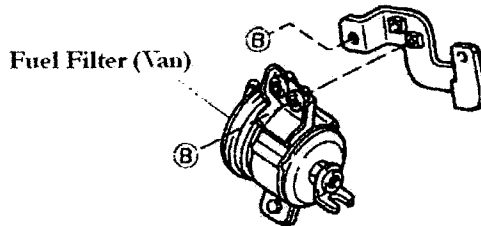
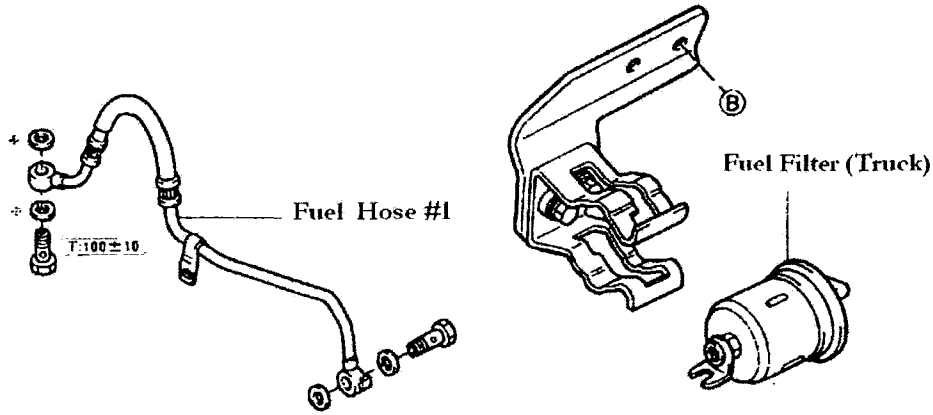

Fuel Pump Relay Location
Van

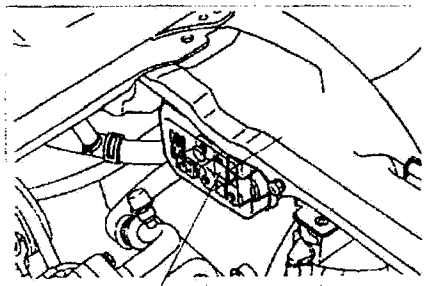

Fuel Pump Relay Location
Truck

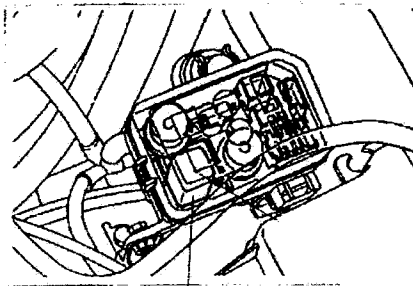

Note: Always Remove Fuel Relay When Changing Fuel Filter (FI Engines)

Note: Fuel Pumps Ohm Rating 0.2~3.0 Ohm

Fuel Filter Part Numbers

EF-ES, EF-TS, S100-S110-S120-S130 Part# 23300-87508-000

EF-ES, S100-S110-(Truck) Part# 23300-87509-000

EF-NS, EF-GS, S100-S110-S120-S130 (Truck) Part# 23300-87502-000

EF-NS (Van) Part# 23300-87510-000

Fuel System

Fuel Tank EF-NS-EF-ES (Truck)

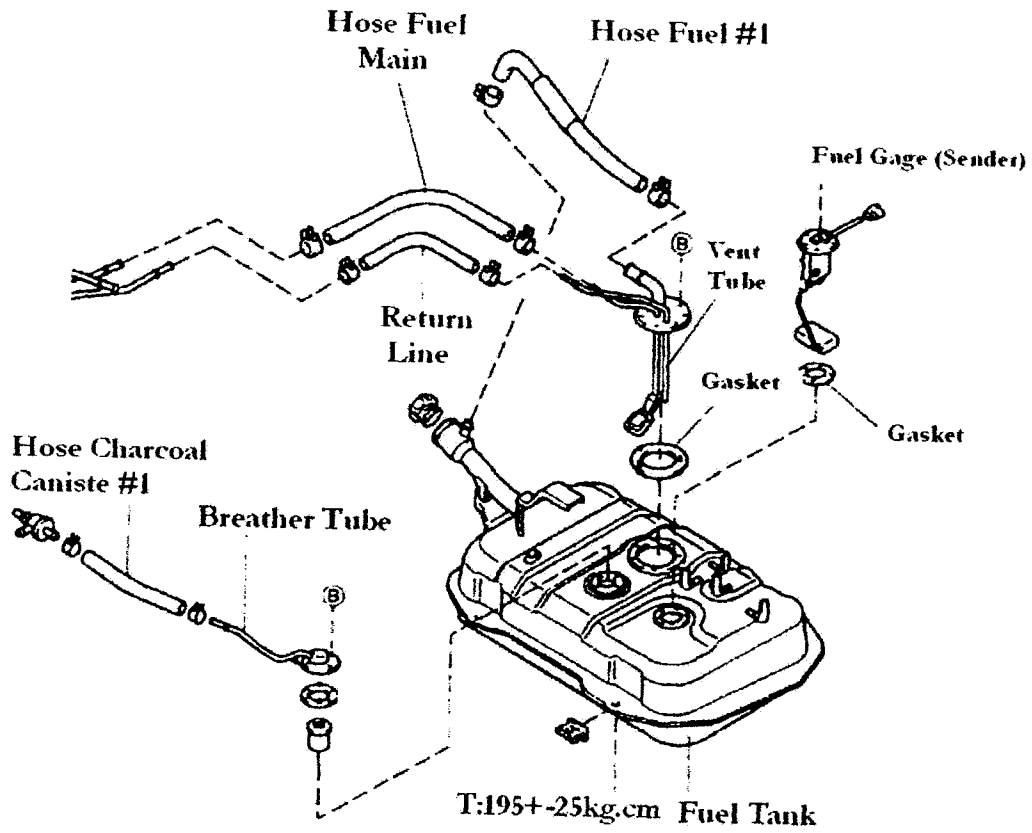

Torque=(kg.cm)

Fuel System

Fuel Tank Components EF-NS - EF-ES - EF-TS (Van)

Torque=(kg.cm)

Note: *=Parts Not Re-usable

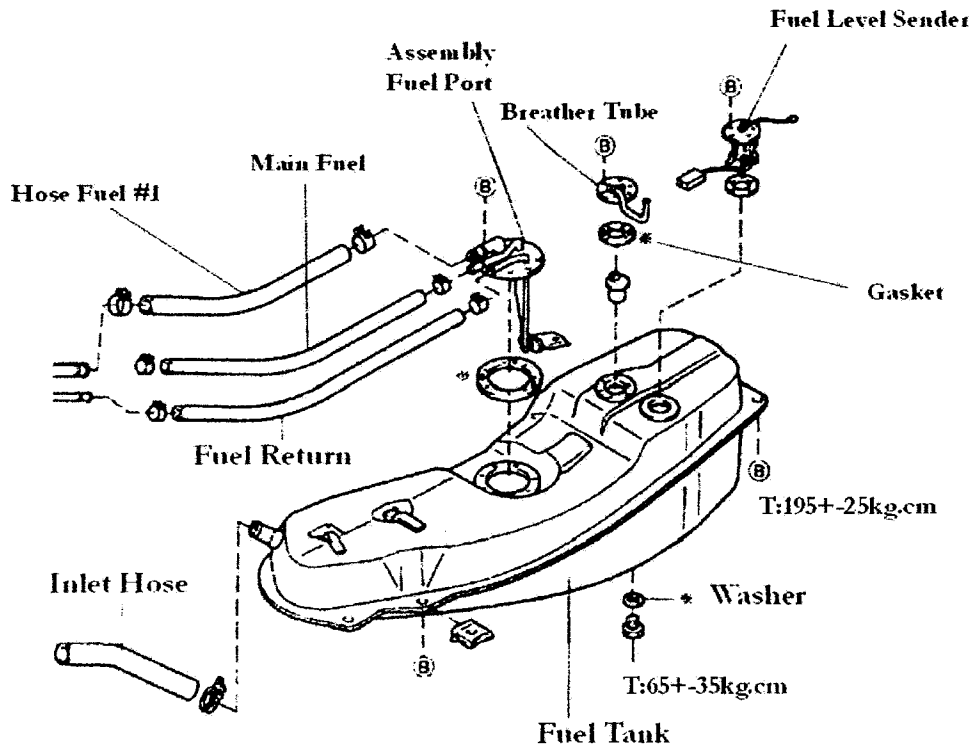

Fuel System

Fuel Injection

Torque: T=kg.cm

Note: *=Must Be Replaced if Dissassembled

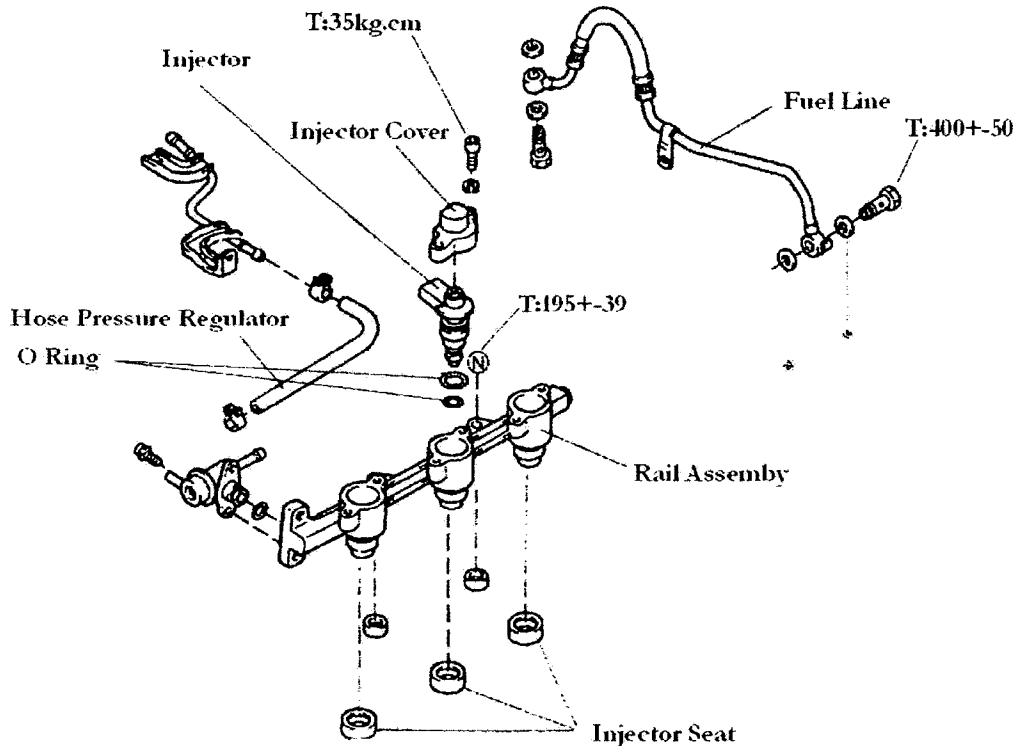

Note: Fuel Injection System Is Controlled by The On-Board Computer. The Special Adapter Cable Listed Below is Required to Check System Funtions.

Engine Control Adapter
Harnes
PN#09991-87705-000



This Adapter Can Also Bypass Fuel Pump Circuit. The Unit Connects Under Drivers Side Steering Wheel Panel

Mechanics Note: 90% of EFI Problems are "Dead Injectors" or Air Leaks. Use a Stethoscope and Listen if Injector is Operating or Not. If Not Check Connetor for Signal or Not. Also Spray a Bit of Carburetor Cleaner Near Injectors and Notice For Idle Speed Change. If Idle Increases or Decreases An Air or Vacuum Leak Has Been Detected. No Injectors Are Operating Change Computer.

Fuel System

Fuel Injection Component Location

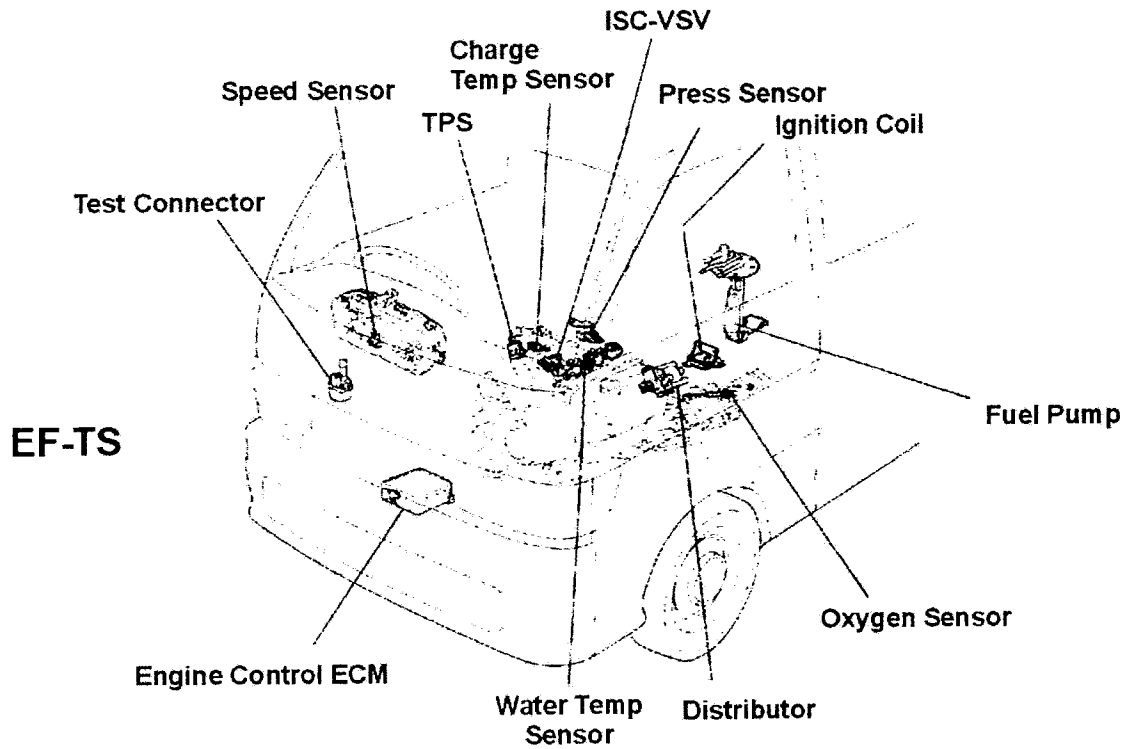
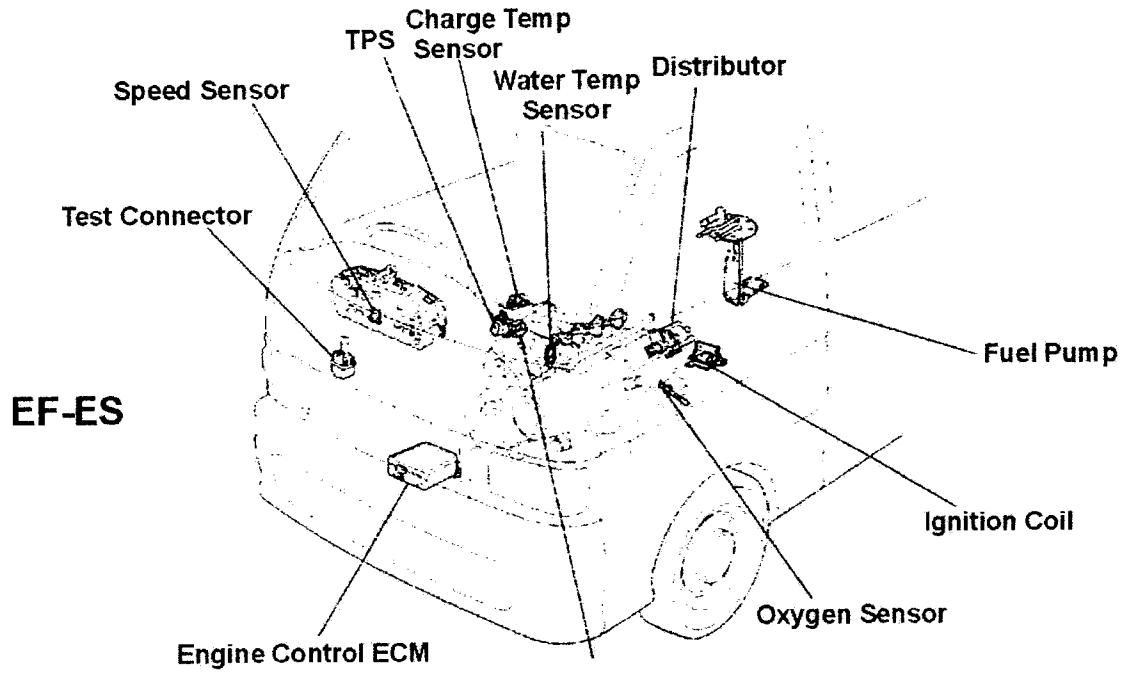

Note: Do Not Confuse Oxygen Sensor With Exhaust Temp Sensor

Engine Control Computer Fuel Injection

EF-ES

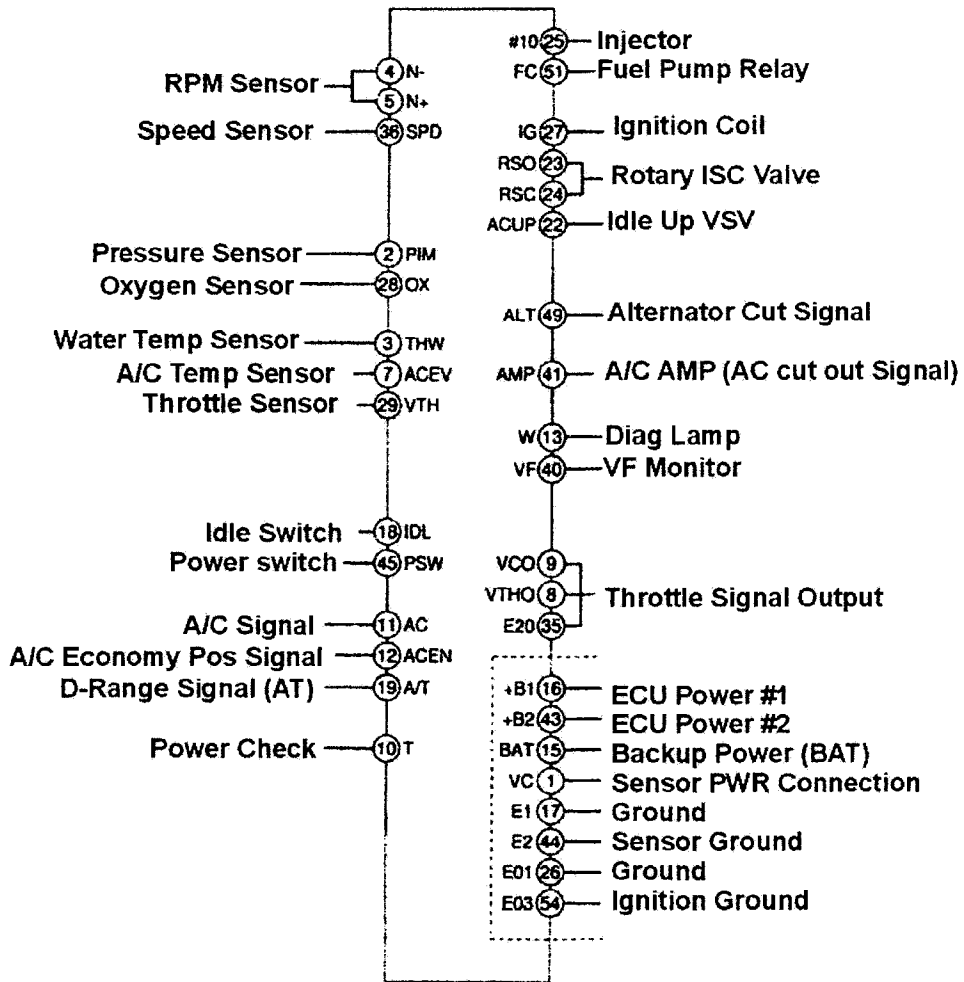

27	26	25	24	23	22	21	20	19	18	17	16	15	14	13	12	11	10	9	8	7	6	5	4	3	2	1
54	53	52	51	50	49	48	47	46	45	44	43	42	41	40	39	38	37	36	35	34	33	32	31	30	29	28

ECU Computer Connector Pin Guide

Fuel System

Fuel Pump

EFNS EFGS Mechanical Fuel Pump
(Cylinder Head Mount)

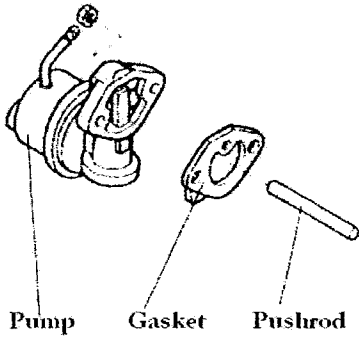

EFGS Electric Fuel Pump
(Body Mount)

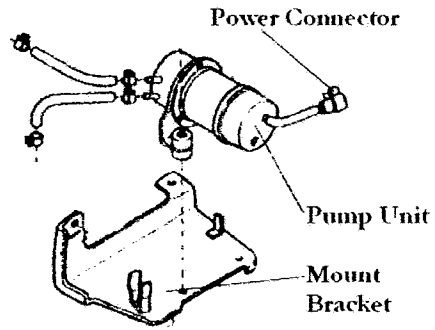

Tank Mount Fuel Pump

EFES-EFTS-EFZS-EFRS

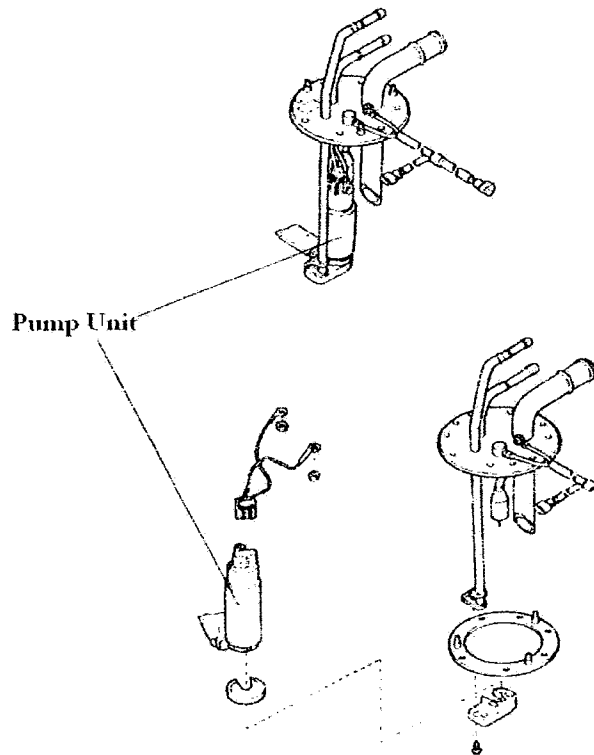

Note: See Following Pages For Vehicle Specific Tank Mount Location

Fuel System

Fuel Lines Diagram EF-NS

Truck

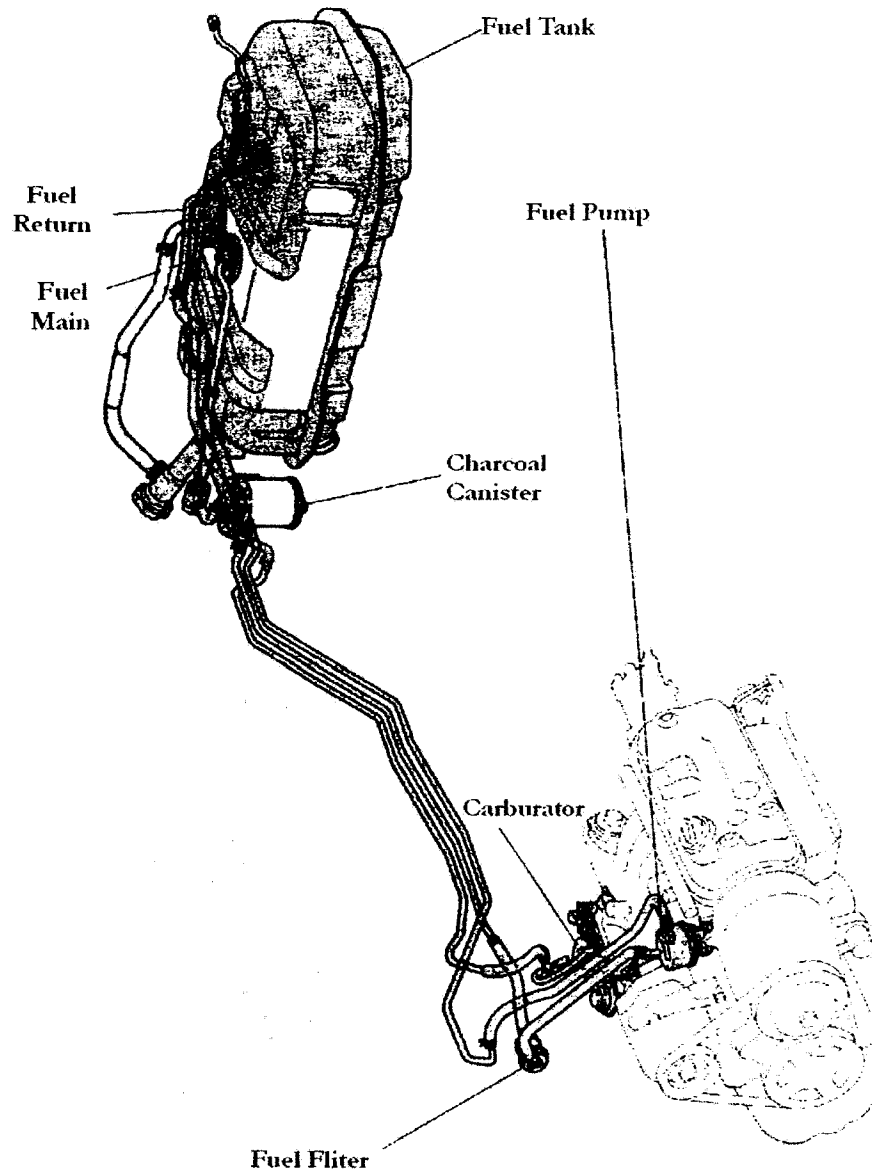

Fuel System

Fuel Line Diagram EF-ES

Fuel Injected Vehicle

Truck

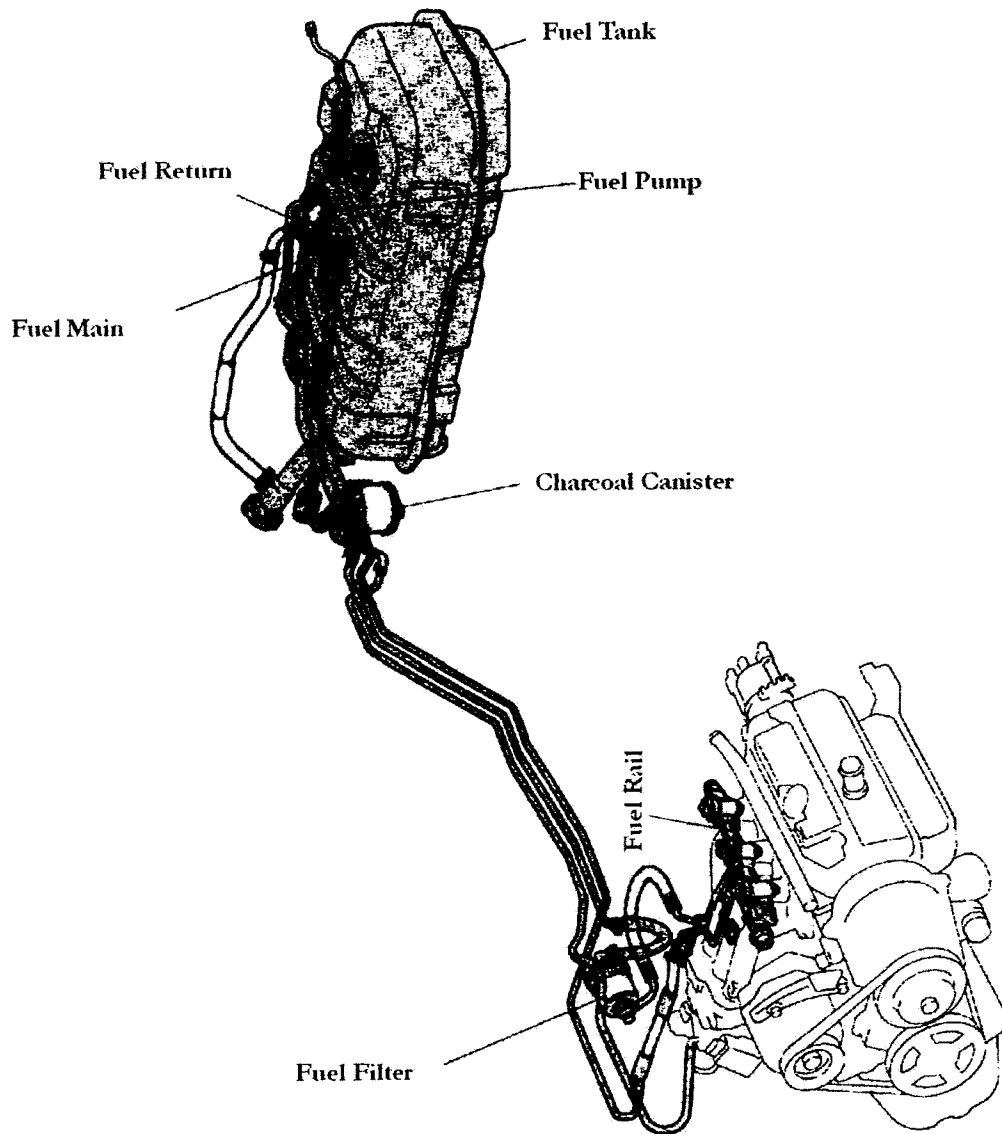

Fuel System

Special Turbo-Charged Vehicle

Fuel Injected Vehicle

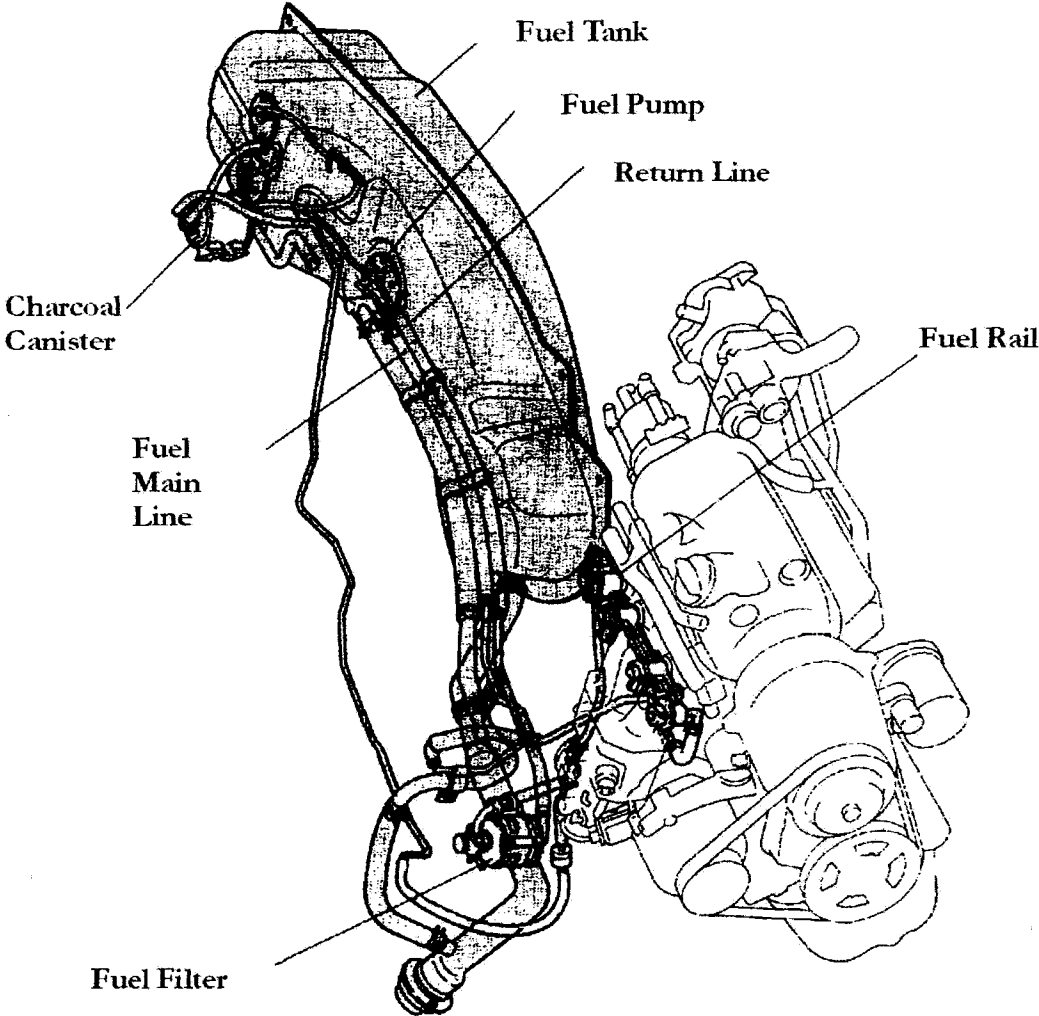

Fuel System

Fuel Lines Diagram EF-NS

Carbureted Van

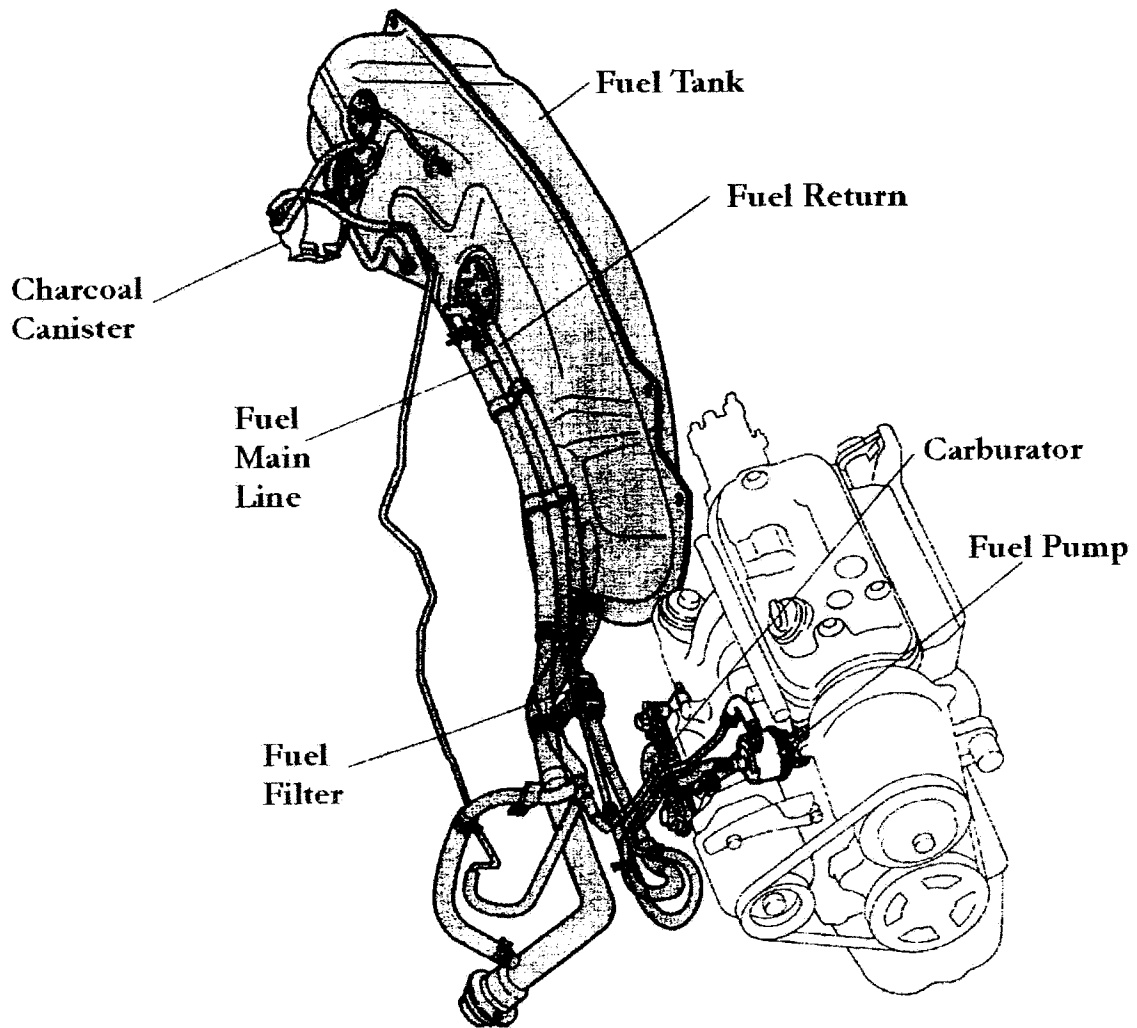

Fuel System

Fuel Lines Diagram EF-ES

Fuel Injected Van

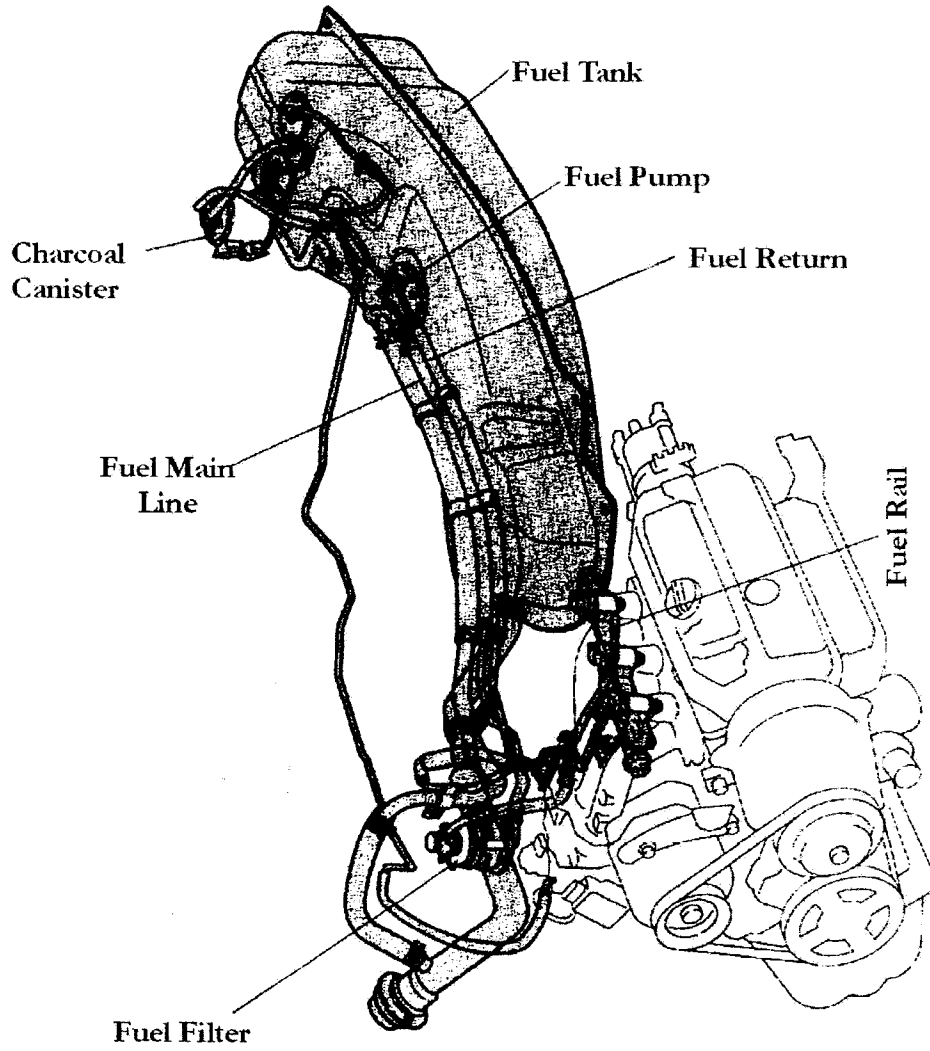

Chapter 10

Emission Control & Vacuum System

- **EFNS Series Vehicles**
- **EFNS Truck**
- **EFNS Van**
- **EFES Series Vehicles**
- **EFES Truck**
- **EFES Van**
- **Others**

Emission Control

EF-NS Series Diagram

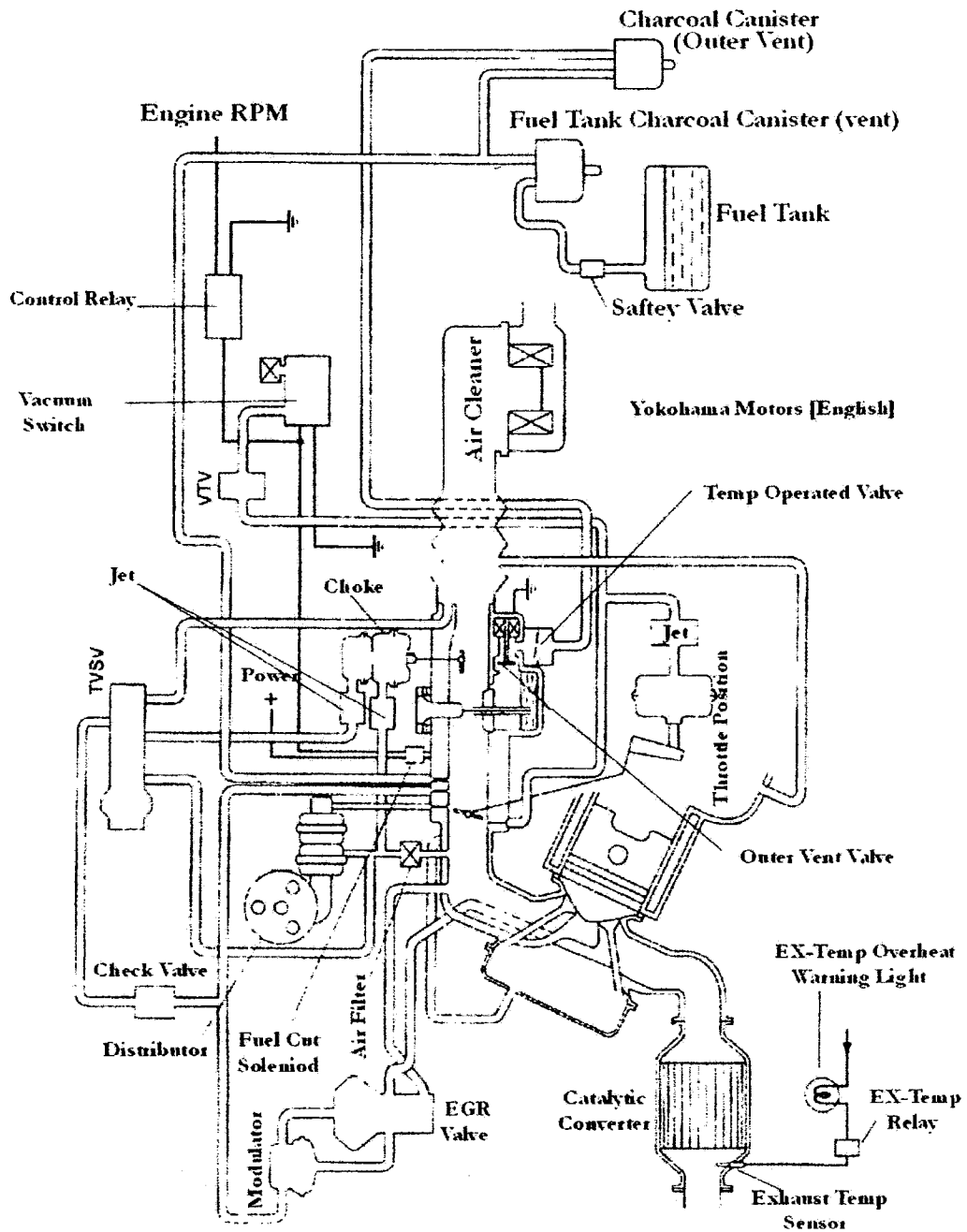

Emission Control

EF-NS (Truck)

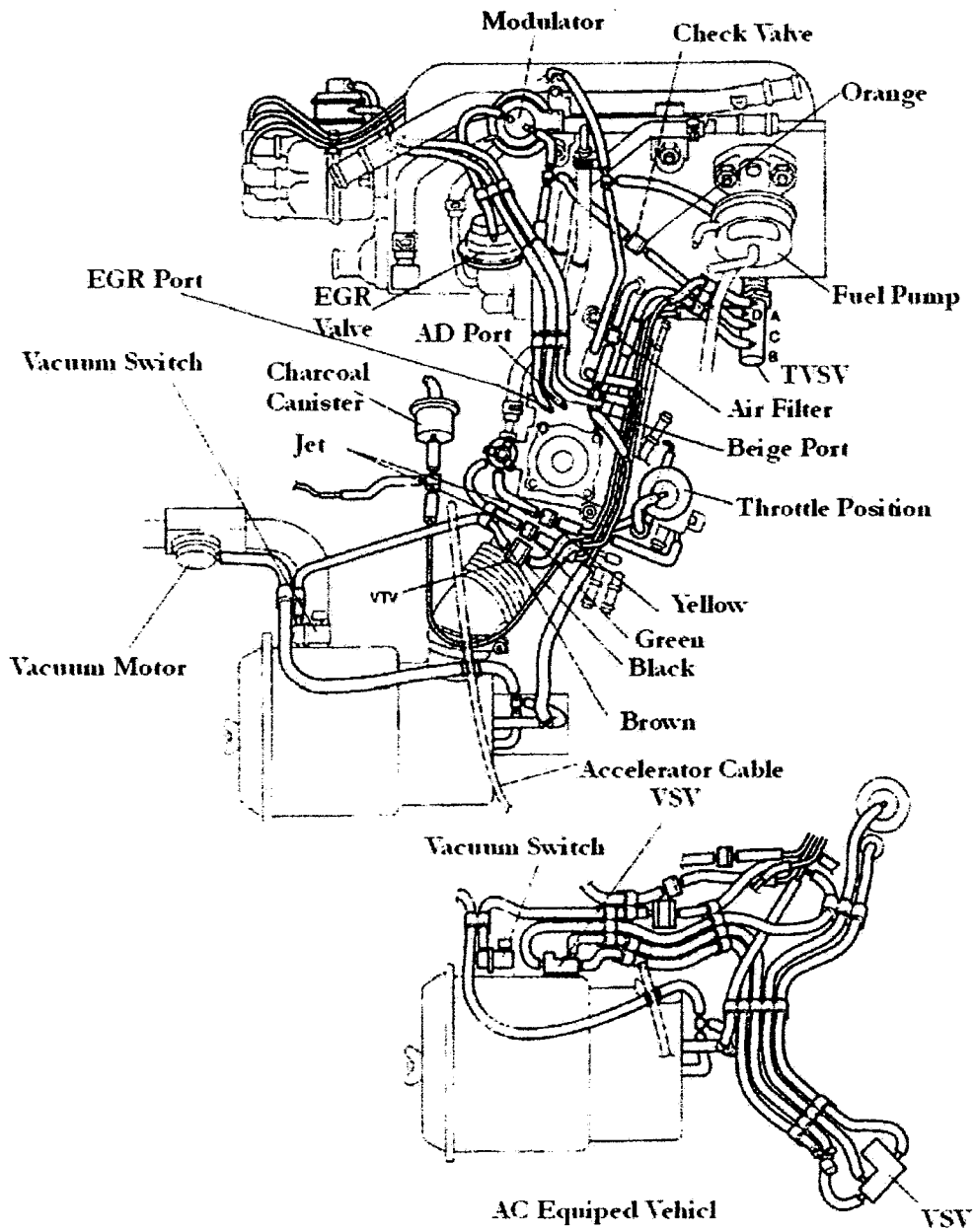

Emission Control

EF-NS (Van)

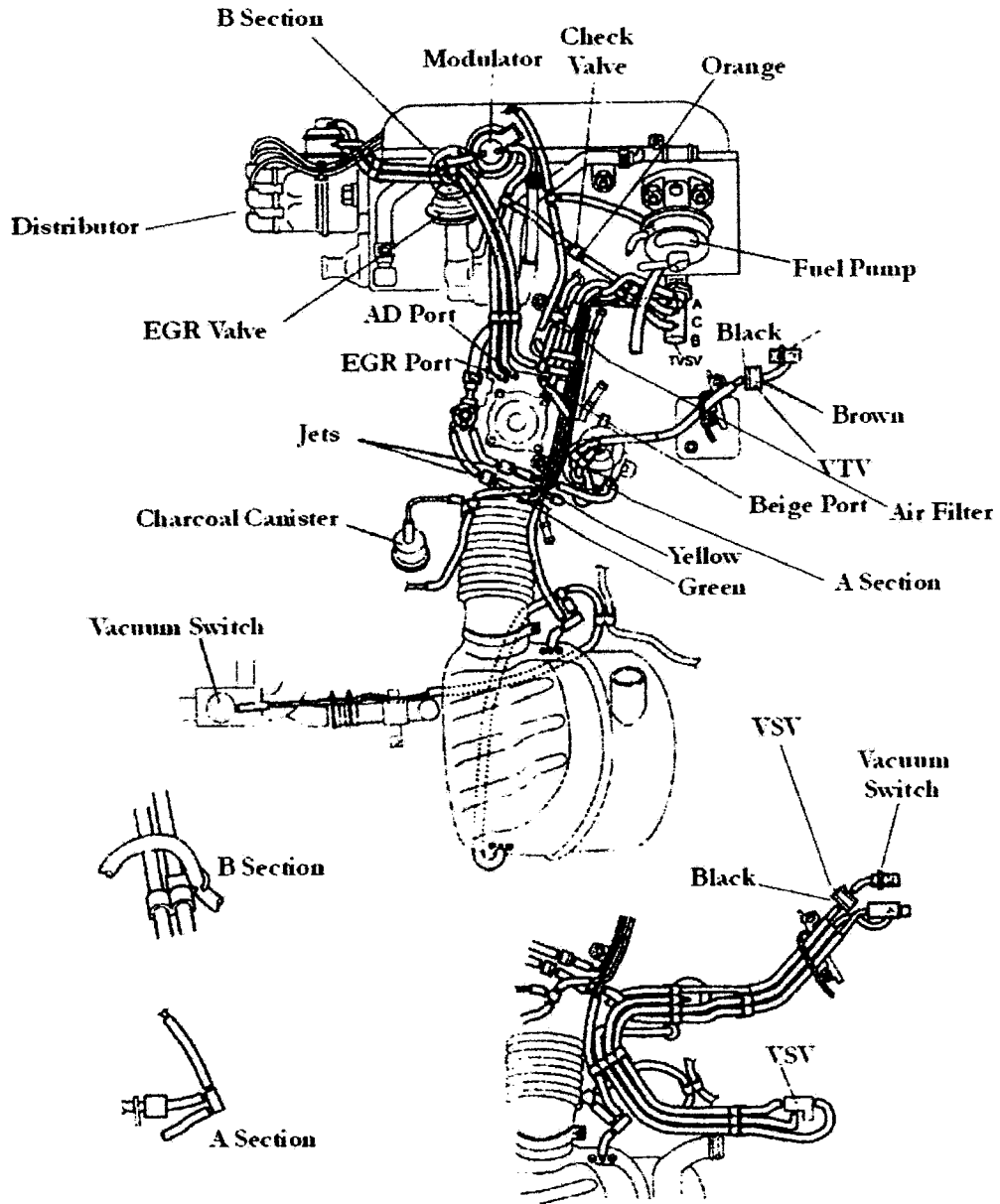

AC Equiped Vehicle

Emission Control

EF-ES Series

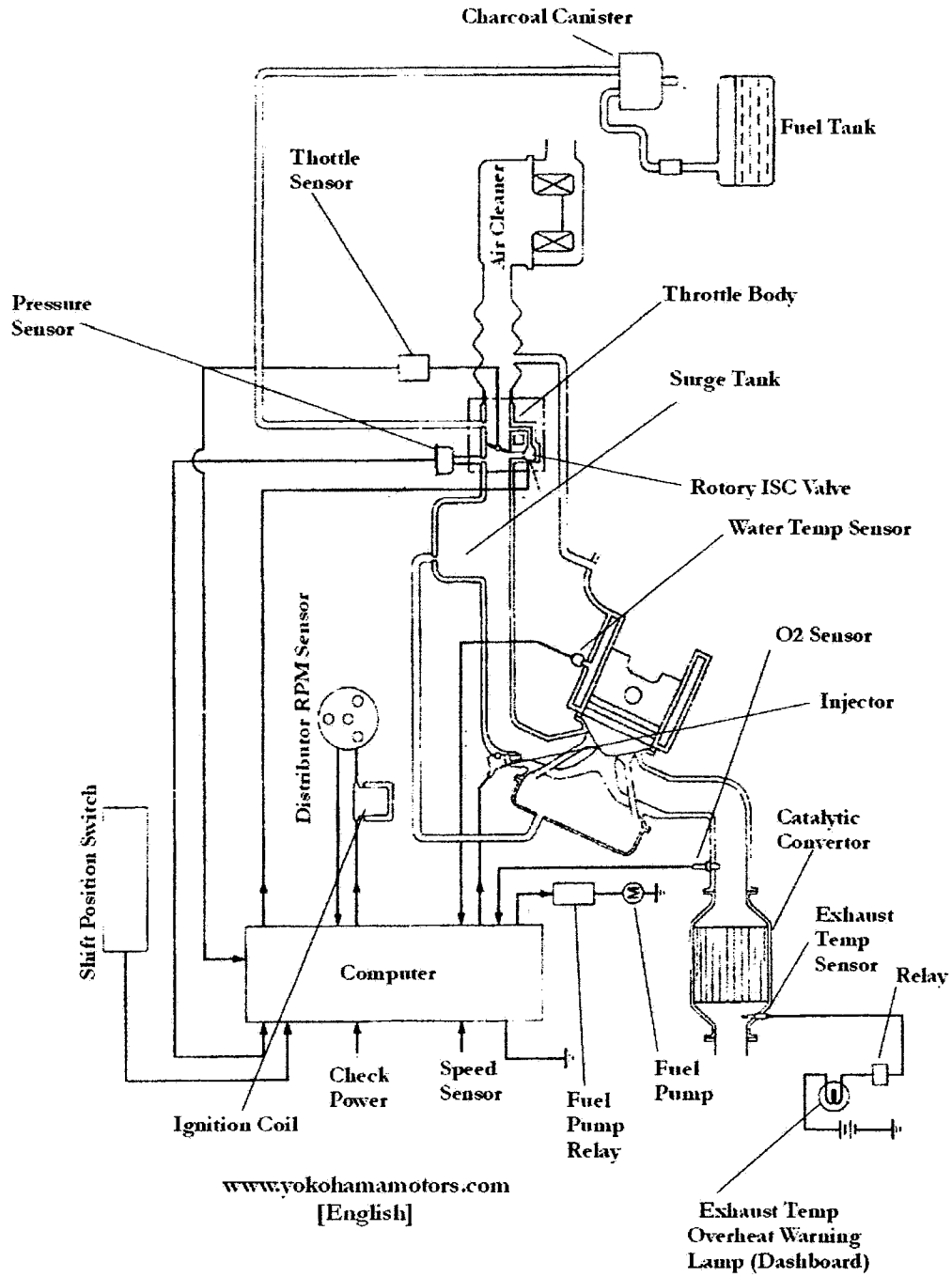

Emission Control

EF-ES (Truck)

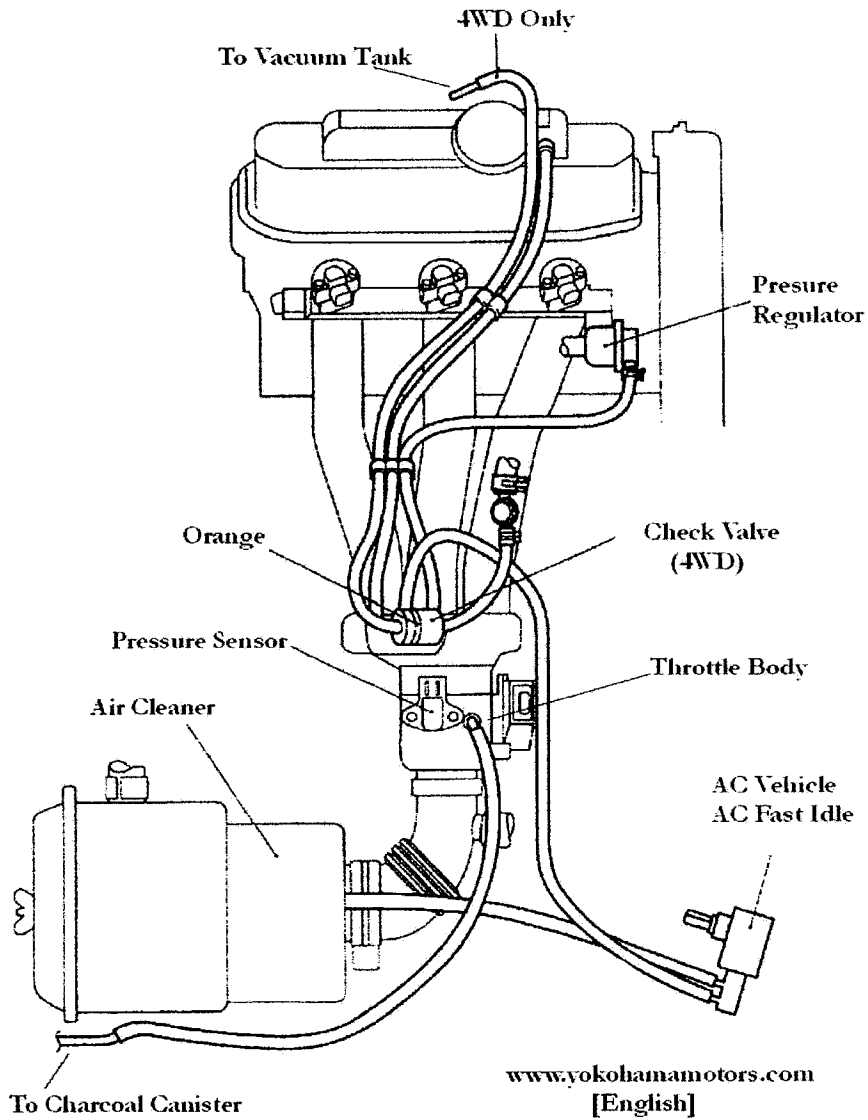

Emission Control

EF-ES (Van)

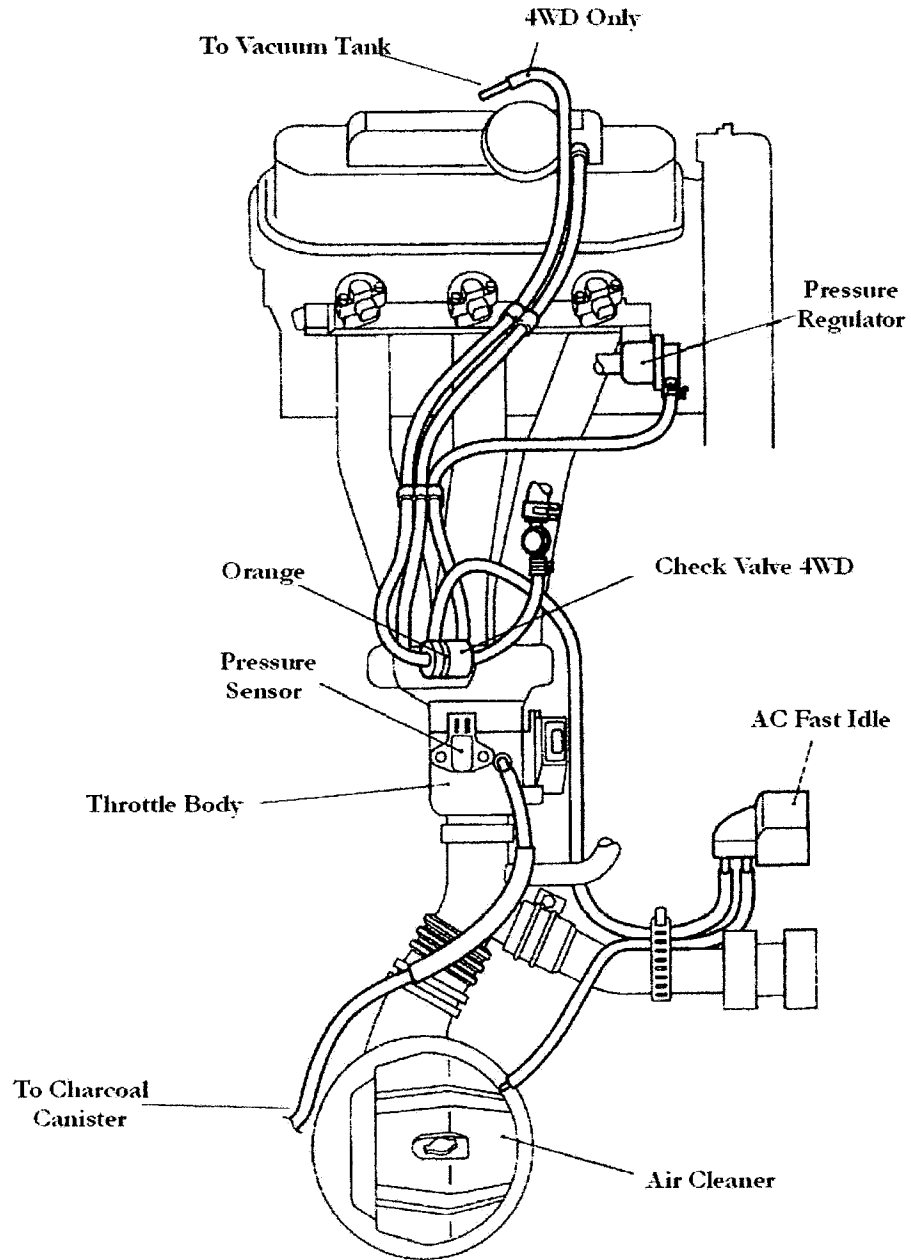

Emission Control

EF-TS Series

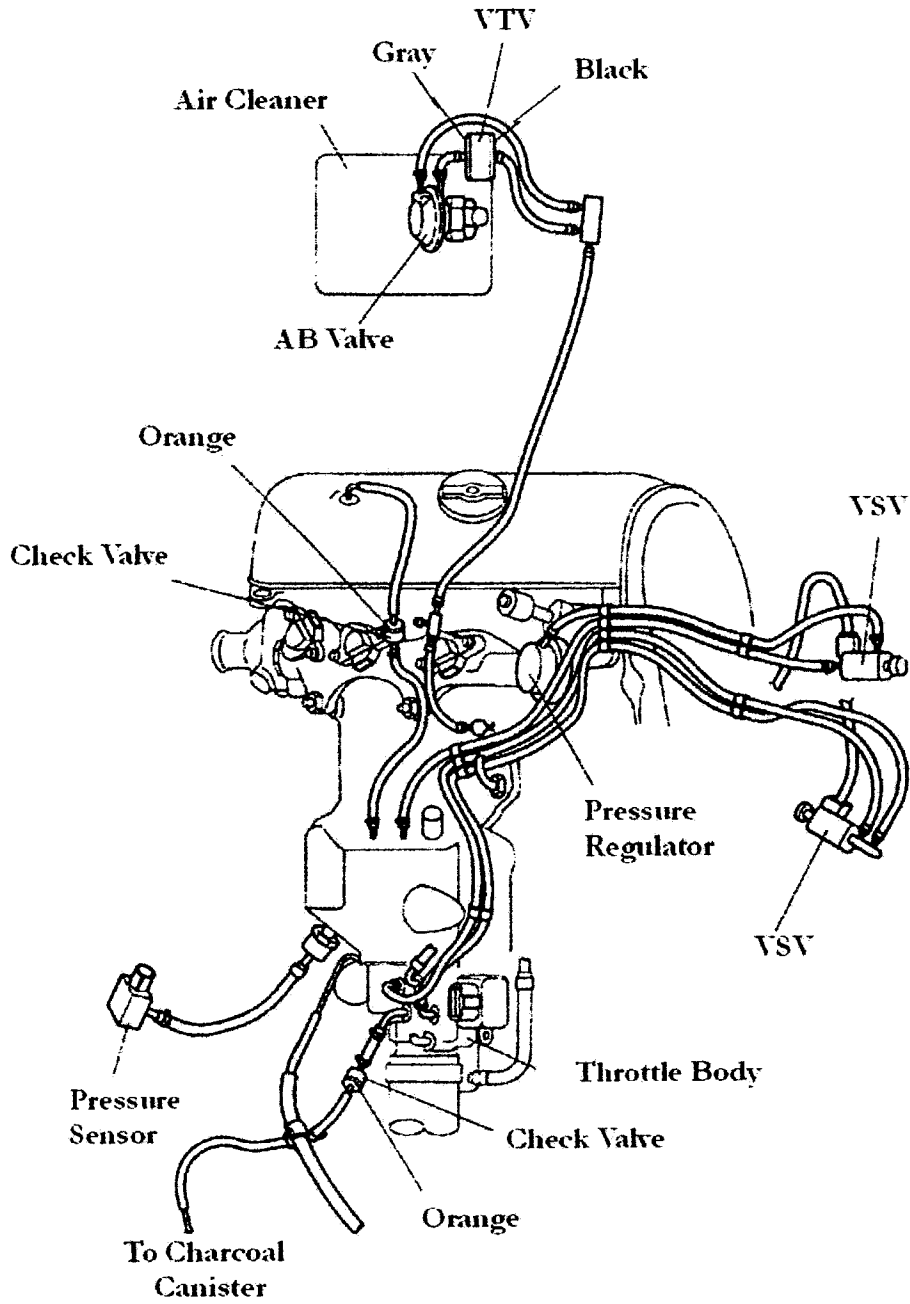

Chapter 11

2WD-4WD

Differentials-Driveshaft(s)-Axels

- Front Differential Components 4WD
- Front Differential Oil Seal Replacement
- Front Differential Mounting System
- Rear Differential Identification and Axle Codes
- Standard Rear Differential Components
- Rear Differential With Diff-Lock Option
- Rear Differential Front Oil Seal Replacement
- Rear Diff-Lock Actuator Removal & Replacement
- Rear Diff-Lock Actuator Vacuum System
- Front Driveshaft Removal & Inspection
- Rear Driveshaft Removal & Inspection
- Rear Axle Removal Tools
- Rear Axle Removal
- Rear Axle Bearing & Oil Seal replacement
- Front Axle (CV Joint) Overhaul
- Driveshaft Parts
- Front Axle Hub Parts
- Front Axle Parts
- Rear Axle Parts

Differential

Front Differential Components 4WD

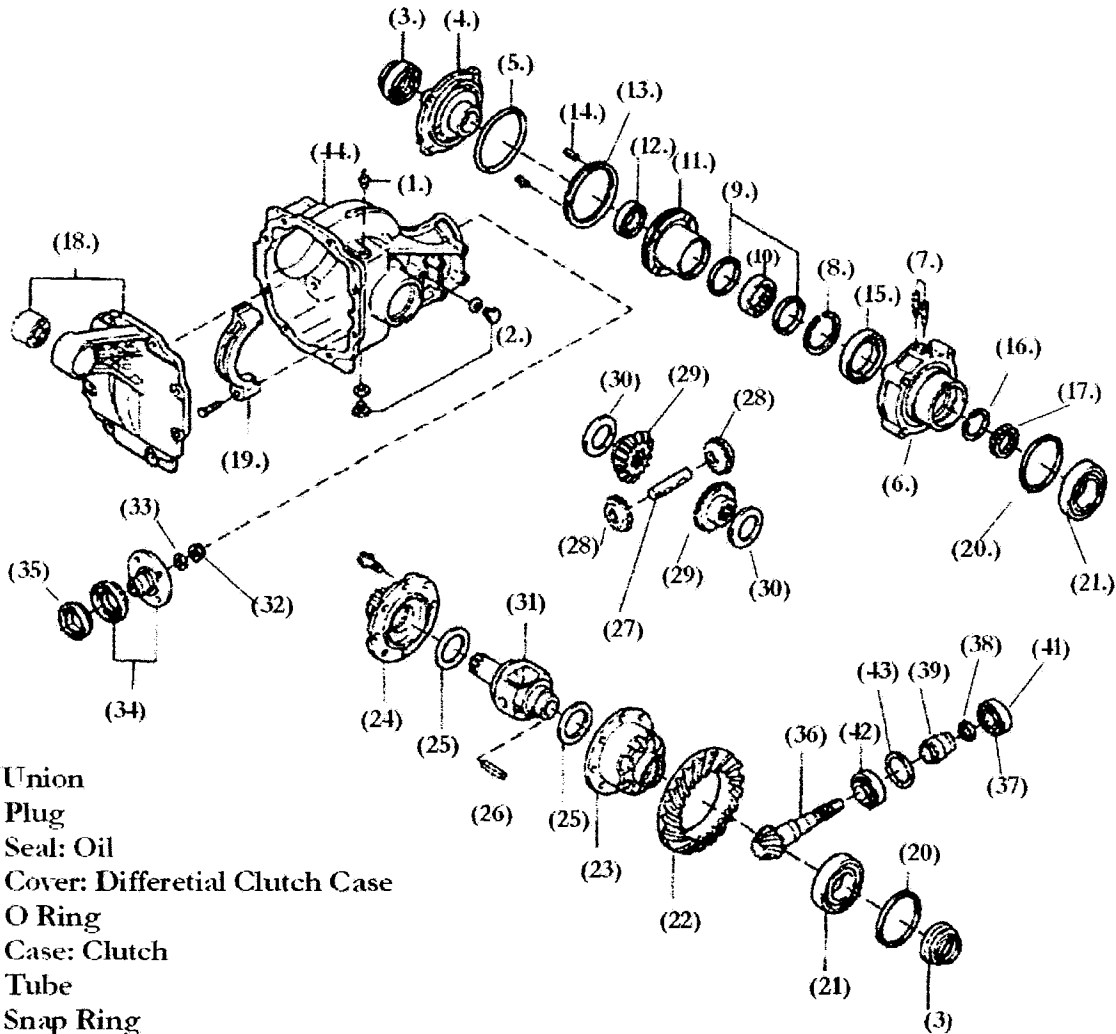

- 1. Union
- 2. Plug
- 3. Seal: Oil
- 4. Cover: Differential Clutch Case
- 5. O Ring
- 6. Case: Clutch
- 7. Tube
- 8. Snap Ring
- 9. Thrust Washers
- 10. Sleeve: Clutch
- 11. Piston: Differential Lock Clutch
- 12. Seal: Oil Type S
- 13. O Ring
- 14. Pin: Slotted
- 15. Seal: Oil Type S
- 16. Snap Ring
- 17. Hub: Clutch
- 18. Front Diff Cover
- 19. Diff Bearing Cap
- 20. Shim
- 21. Bearing
- 22. Ring Gear
- 23. (LH) Case: Ring Gear Housing
- 24. (RH) Case: Ring Gear Housing
- 25. Thrust Washer

- 26. Slotted Pin
- 27. Shaft: Pinion
- 28. Shaft Gear
- 29. Side Gears
- 30. Thrust Washer
- 31. Case
- 32. Nut
- 33. Washer
- 34. Flange
- 35. Seal: Type T Oil
- 36. Pinion: Drive
- 37. Bearing
- 38. Shim
- 39. Spacer
- 40. Front Bearing
- 41. Outer Race
- 42. Outer Race

- 43. Shim
- 44. Differential Carrier

Differential

Front Differential Flange Oil Seal Replacement

Tools

Pinion Flange Holder



#09330-87301-000

Puller: Oil Seal

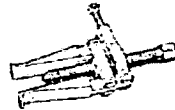

#09308-10010-000

Oil Seal Installer



#09635-20010-000

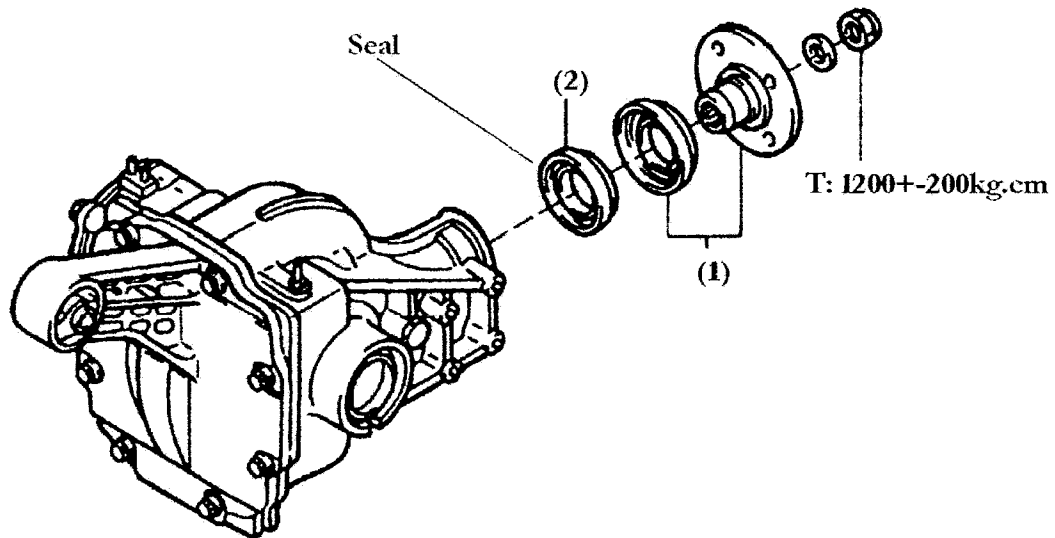

1. Flange S/A: Drive Pinion
2. Oil Seal: Type T

Differential

Front Differential Oil Seal Replacement

1. Lift Up Vehicle
2. Remove Drive Shaft

3. Attach Special Tool (Flange Holder) as in Diagram on Right. Hold onto Holder and Use Breaker Bar to Remove Attachment Nut

Note: Nut Must Be Replaced

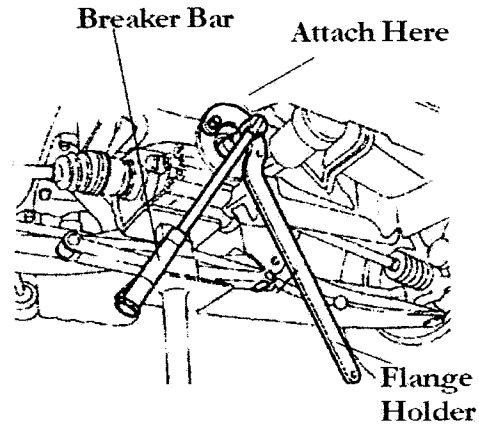

4. Use Oil Seal Puller as in Diagram to Right.
Tool: 09308-10010-000

5. Remove Oil Seal and Discard

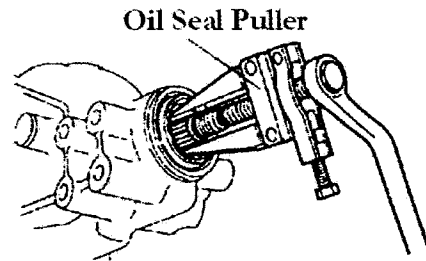

6. Clean Surfaces and Coat With Long Life Chassis Grease. Install New Seal. Use Oil Seal Installer Tool and Tap Into Place

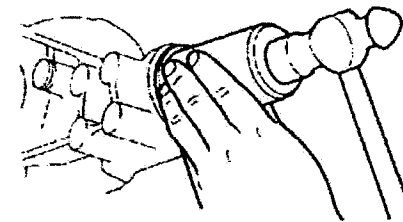

7. Use Holder Tool and Torque Wrench to Attach Nut

Torque Specification: 1200+ -200kg.cm

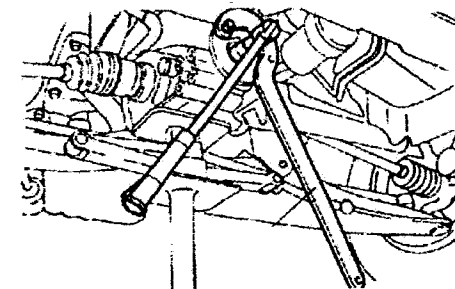

Differential

Front Differential Mouning Brackets

Torque: =kg.cm

(B)=Bolt

(N)=Nut

(W)=Washer

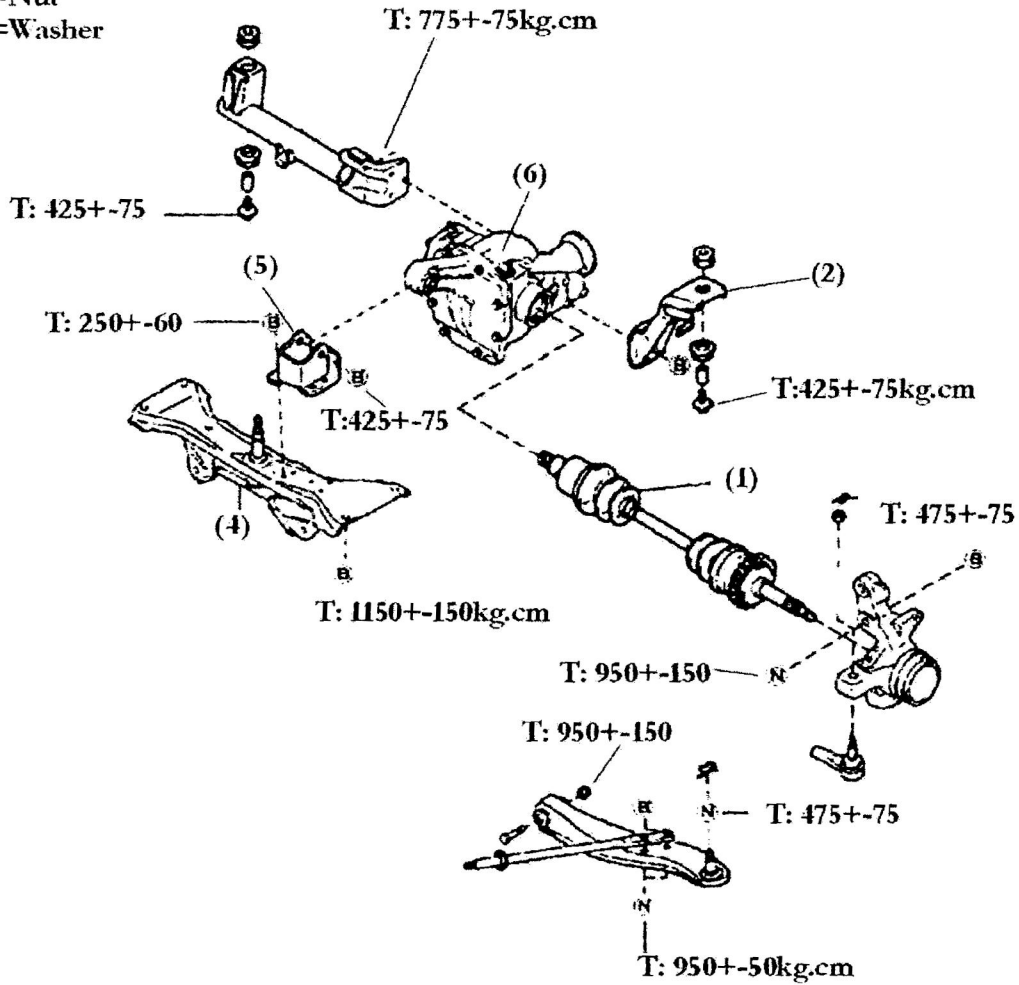

1. Front Drive Axel
2. Bracket: Differential Gear Support Rear Left
3. Bracket: Differential Gear Support Rear Right
4. Cross-member
5. Bracket: Front Differential Support
6. Carrier Assembly

Differential

Rear Axel Codes

Example: 50=Ratio 5.571 S120V EFTS Series

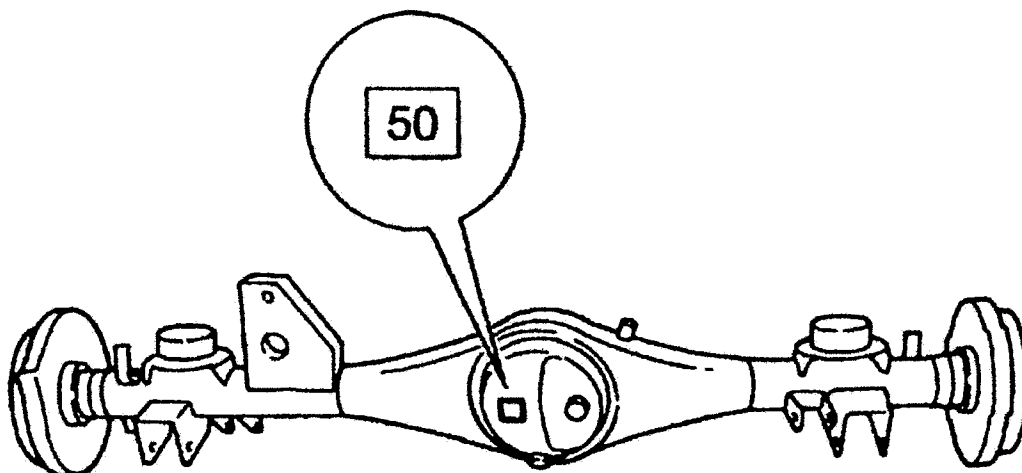

Gear Ratio	Mark	Series
6.666	01-03	SP100P
6.285	05	SP100P/SP110P
6.666	09-11-13	SP110P
6.285	17	SV100
6.666	61-21-62	SV100V/S100V
6.285	29	EFES S120V
5.571	49-50-51-52	EFTS S120V
6.666	33-37	EFES
5.875	41~48, 53	S130V EFES EFTS

Differential

Standard Rear Differential

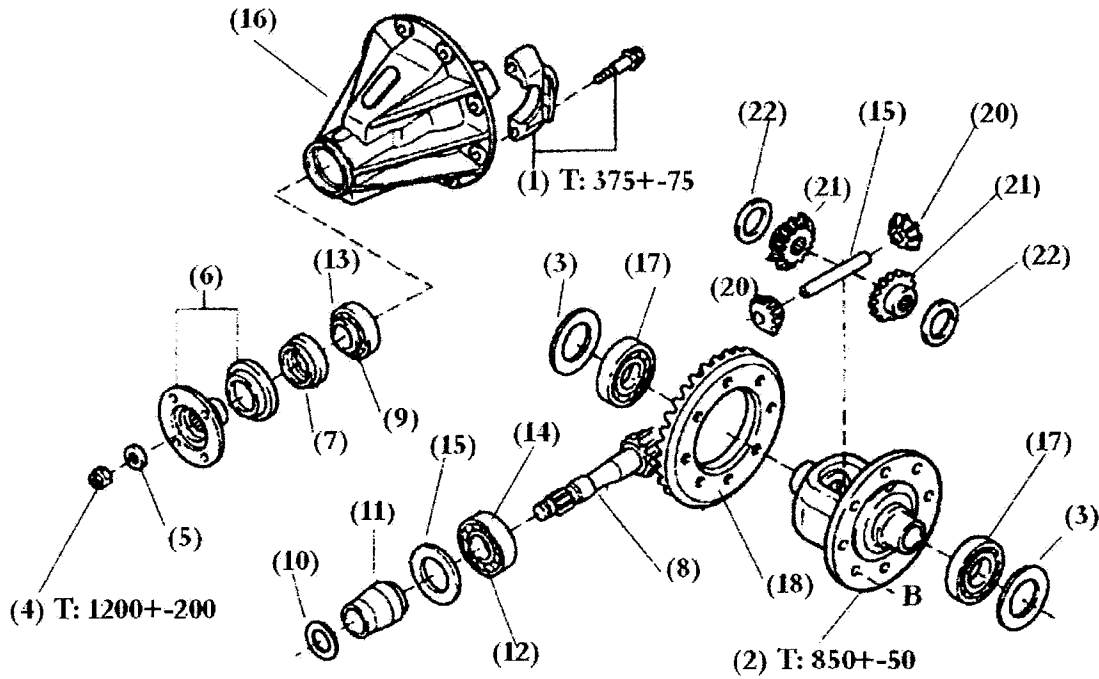

- | | |
|-------------------------------|--------------------------------|
| 1. Cap: Bearing | 13. Outer Race: Front |
| 2. Case Assembly | 14. Outer Race: Rear |
| 3. Shim | 15. Shim |
| 4. Nut | 16. Carrier Case |
| 5. Washer | 17. Bearing |
| 6. Flange Assembly | 18. Ring Gear |
| 7. Seal: Oil Type T | 19. Shaft: Differential Pinion |
| 8. Pinion: Differential Drive | 20. Pinion Gear |
| 9. Bearing: Tapped Lower | 21. Side Gear |
| 10. Shim | 22. Washer: Side Gear Thrust |
| 11. Spacer | |
| 12. Bearing: Tapped Lower | |

Differential

Rear Differential W/ Diff-Lock Option

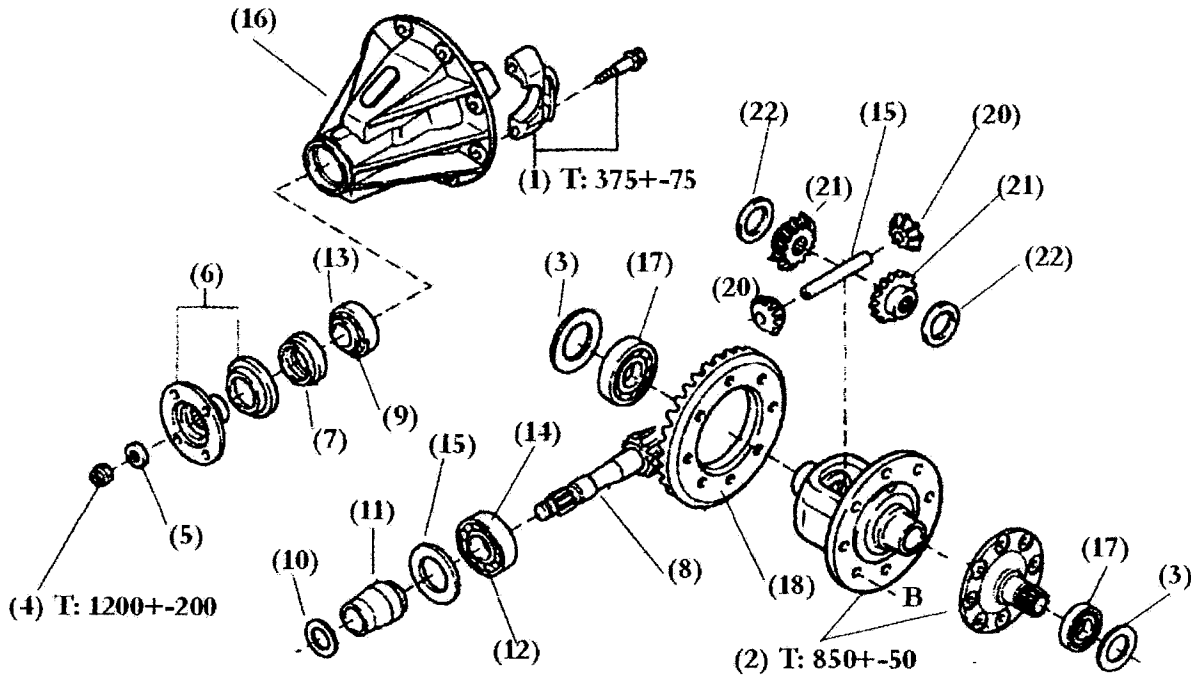

- | | |
|-------------------------------|--------------------------------|
| 1. Cap: Bearing | 13. Outer Race: Front |
| 2. Case Assembly | 14. Outer Race: Rear |
| 3. Shim | 15. Shim |
| 4. Nut | 16. Carrier Case |
| 5. Washer | 17. Bearing |
| 6. Flange Assembly | 18. Ring Gear |
| 7. Seal: Oil Type T | 19. Shaft: Differential Pinion |
| 8. Pinion: Differential Drive | 20. Pinion Gear |
| 9. Bearing: Tapered Lower | 21. Side Gear |
| 10. Shim | 22. Washer: Side Gear Thrust |
| 11. Spacer | |
| 12. Bearing: Tapered Lower | |

Differential

Rear Differential Front Oil Seal Replacement

Tools

Flange Holder



#09330-87301-000

Oil Seal Puller

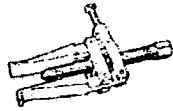

#09308-10010-000

Seal Installer



#09635-20010-000

1. Flange Assembly
2. Oil Seal Type T

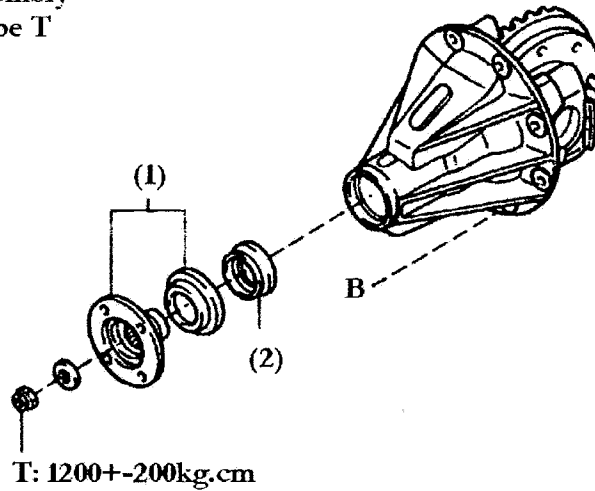

Replacement

1. Jack Up or Lift Up Rear of Vehicle
2. Remove Drive Shaft

Differential

Rear Differential Front Oil Seal Replacement

3. Attach Flange Holder Tool and Use Breaker Bar to Remove Retainer Nut

Note: Nut Must Be Replaced

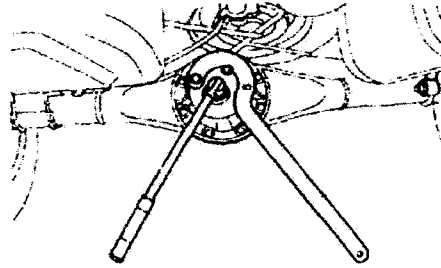

4. Use Oil Seal Puller Tool and Remove Oil Seal

Note: Seal Must Be Replaced

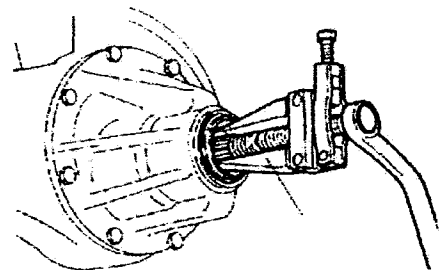

5. Grease New Seal With 90W Differential Oil and Install With Oil Seal Installer

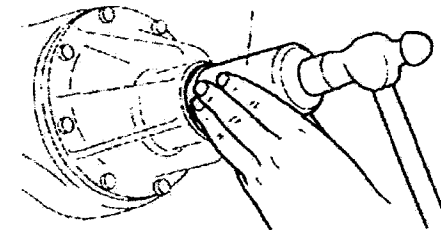

6. Attach Flang Holder Tool and Use a Torque Wrench to Set to Specification

Torque: 1200+-200kg.cm

7. Install Driveshaft

8. Check Differential Oil

Differential Oil: SAE90
Capacity: 1.3 Liters

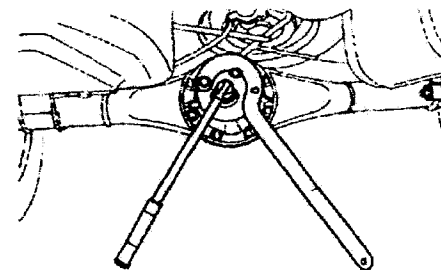

Differential

Diff-Lock Actuator Option Vehicle

Note: Majority of Diff-Lock Problems are Vacuum Related

(B)=Bolt

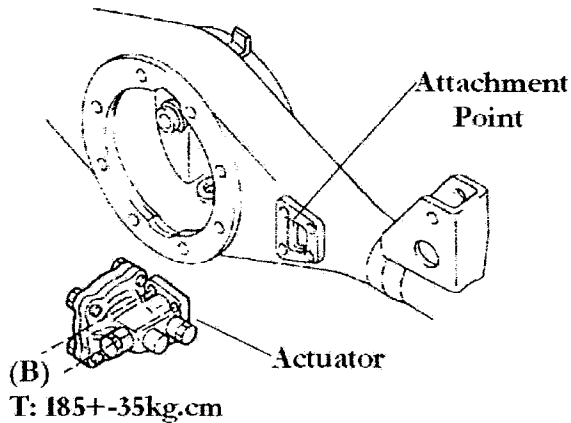

Removal

1. Lift Up Vehicle
 2. Remove (2) Vacuum Hoses
 3. Remove (4) Attachment Bolts
- Note: Sensor Equipped Disconnect Connector

Installation

1. Clean Surfaces
2. Attach New Gasket
3. Use Diagram on Right to Line Up Arm and Slot
4. Attach Bolts & Torque: 185+-35kg.cm
5. Check Differential Oil and Add if Low

OIL: SAE90W (API-GL5)
Capacity: 1.3 Liters

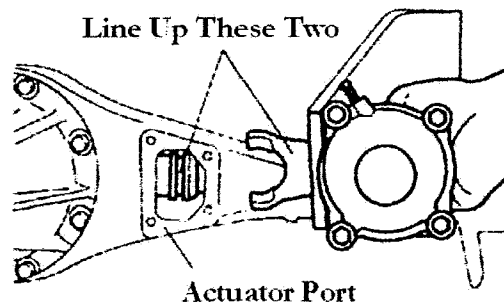

Actuator Testing

1. Remove Actuator

Note: Do NOT Spray Caburetor Cleaner Into Vacuum Port! Unit Will Be Destroyed

2. Attach Hand Held Vacuum Pump and Draw 450mmHG Through Vacuum Port. Actuator Arm Will Move Left (Inwards). Hold Vacuum 20~30 Seconds. No Bleed Down and Unit is Fine. Unit Bleeds Down Less Than 15 Seconds Actuator Should Be Replaced

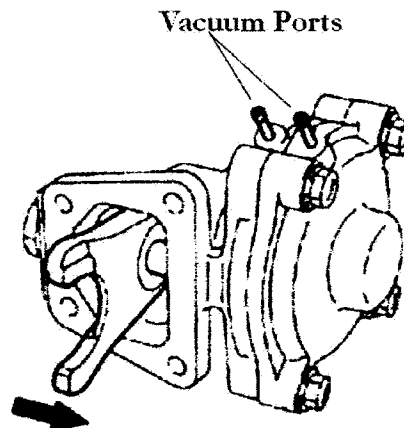

Differential

Diff-Lock System Diagram

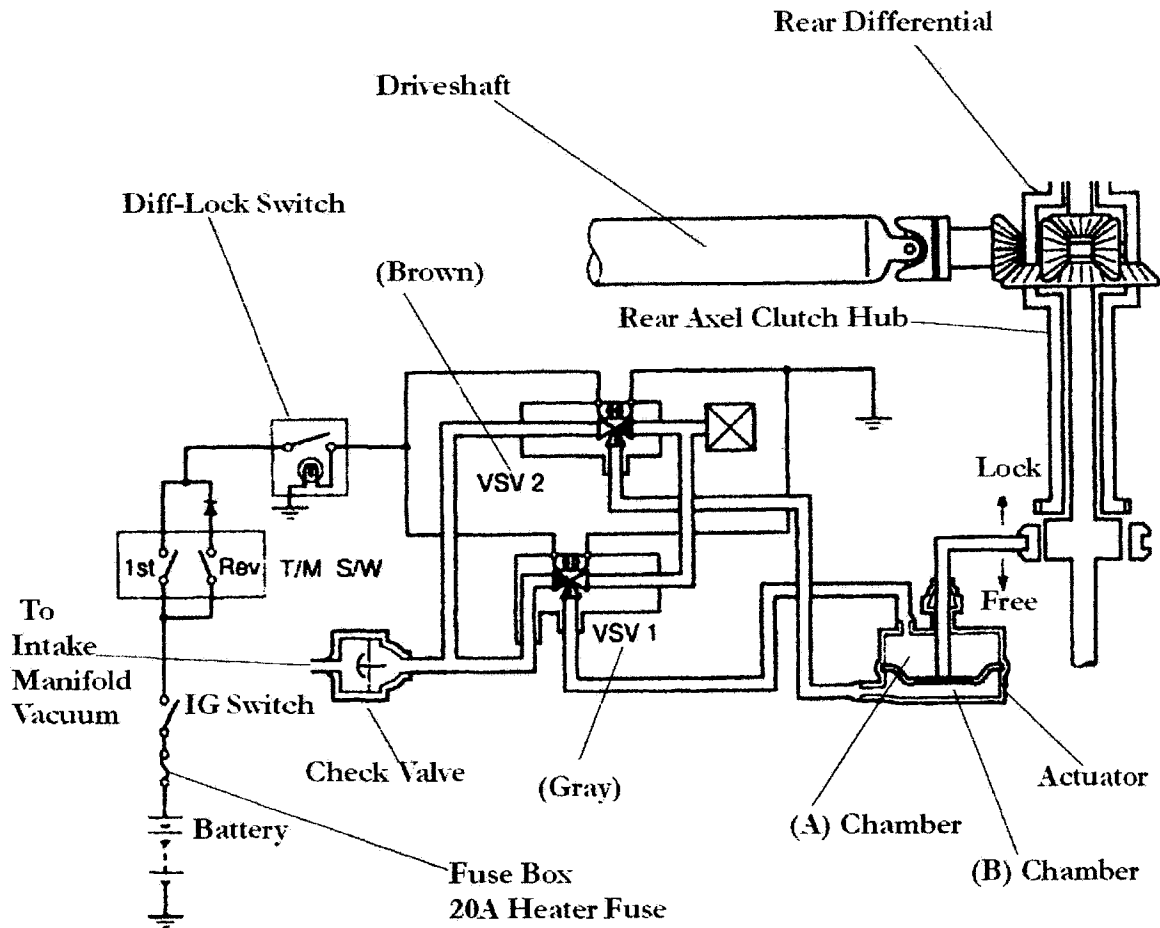

Note: Common Problems 1. Check Valve 2. Leak in Hose 3. Vacuum Port Switched

Caution: Never Spray Carburetor Cleaner in Vacuum Lines! Check Valve and Actuator Diaphragm Will Be Destroyed

Caution: Vacuum Leaks Will Cause Idling Problems

Driveshaft

Front Driveshaft & Removal

Torque:=kg.cm
(B)=Bolt

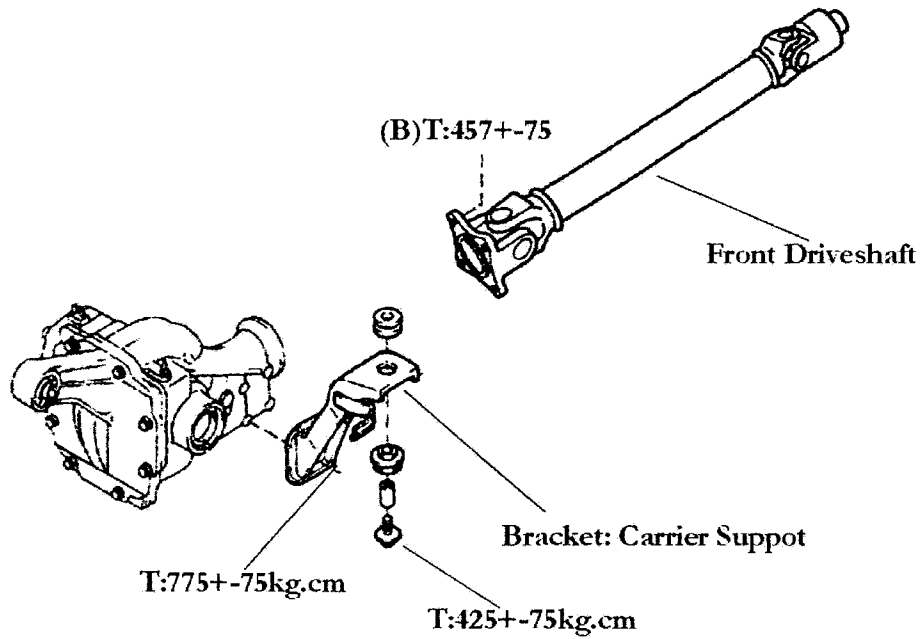

Removal

1. Lift Vehicle
2. Use Yellow Paint and Mark Present Position of Flange and Yoke. This Mark Will Be Used for Installation Guidance.

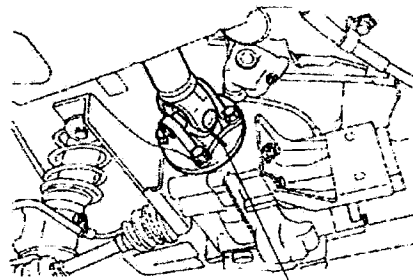

Driveshaft

Front Driveshaft Removal

3. Support Differential
4. Remove the (5) Bolts Supporting the Rear Left Carrier Support Bracket as Seen in the Right Side Diagram

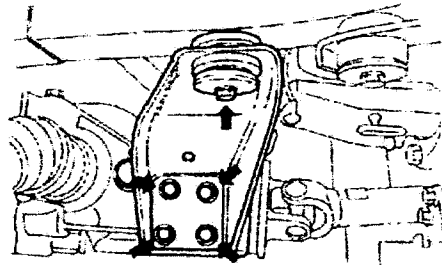

5. Pull Back Driveshaft 5~10cm and Move Front Portion to Left Side of Vehicle. Pull Driveshaft Forward and Remove From Vehicle. Oil From Transfer Case May Leak Out, Place a Bucket Under Transfer Case

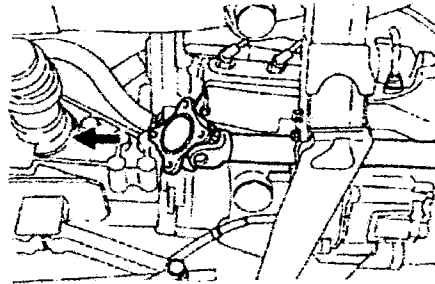

6. Use a Dial Gage and Inspect Driveshaft Round-Out

Limit: Below 1.0mm

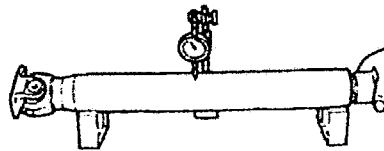

7. Universal Joint Test: Follow the Diagram on Right and Test All Direction Movement. If Failure Replace Universal Joint.

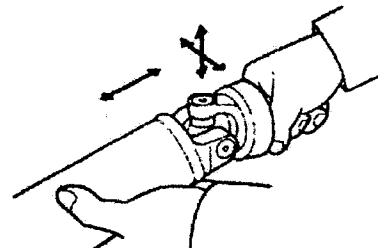

Driveshaft

Front Driveshaft Installation

8. Install Driveshaft and Support Bracket

Bracket Torque:

Differential Side: 775+-75kg.cm

Body Mount: 425+-75kg.cm

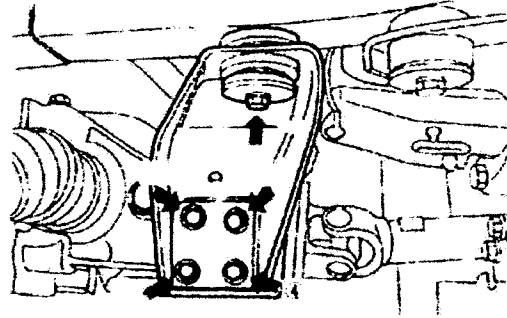

9. Torque Driveshaft: 475+-75kg.cm

10. Check Transfer Case Oil and Add if Low

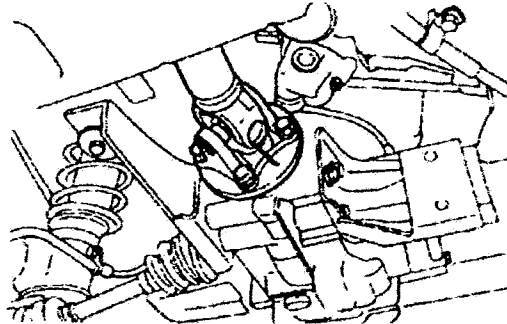

Transfer Case Oil Specifications

SAE 75W-85W (API-GL-3)

Capacity: 2.3 Liters (MT) and 1.6 Liters (AT)

Driveshaft

Rear Driveshaft Removal & Replacement

1. Raise Vehicle
2. Use Yellow Paint and Mark Driveshaft Position
3. Remove Attachment Bolts
4. Slide Driveshaft Forward (Front of Vehicle) and Lower Out
5. Use a Dial Gage and Inspect Driveshaft Round-Out

Limit: 1.0mm

6. Using the Diagram on the Right Perform the Following Travel Movements. If Universal Joint Experiences Binding, Replace U-Joint

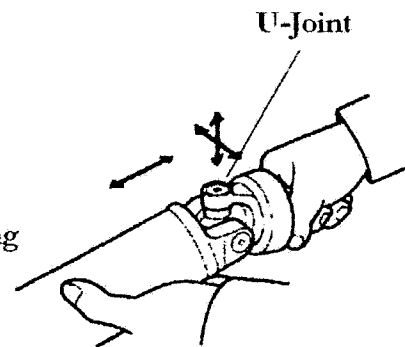
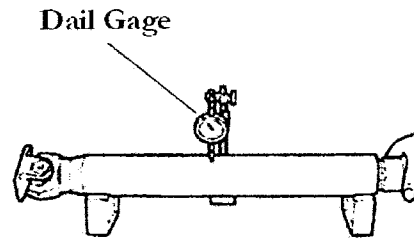

7. Install Driveshaft in Reverse Order, Align Paint Mark

8. Torque Bolts to: $475 \pm 75 \text{ kg.cm}$

9. Check Transmission Oil and Differential Oil Levels. Add if Required

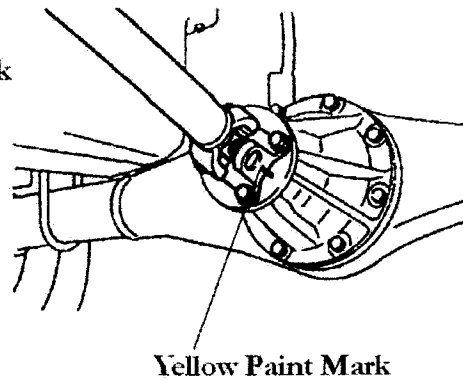

Axel

Rear Axel Removal Tools

Brake Drum Holder

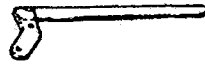

#09511-87202-000

Slide Hammer



#09912-87501-000

Oil Seal Puller



#09308-00010-000

Puller Adapter

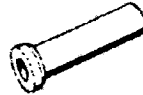

#09309-87201-000

Adapter

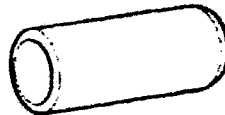

#09257-87201-000

Adapter



#09515-21010-000

Axel

Rear Axel Removal

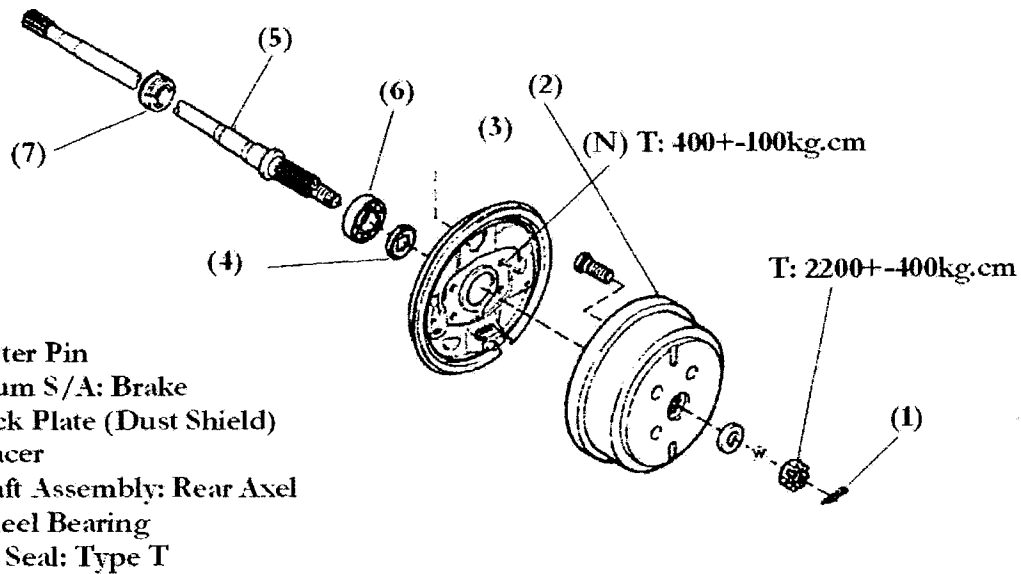

Axel Removal

1. Raise and Support Rear of Vehicle
2. Remove Rear Wheels
3. Drain Rear Axel Oil

Note: Drain Seal Must be Replaced

4. Remove and Discard Cotter Pin

Note: Cotter Pin Must Be Replaced

5. Attach Drum Holder Tool and Use Breaker Bar To Remove Castle Nut.

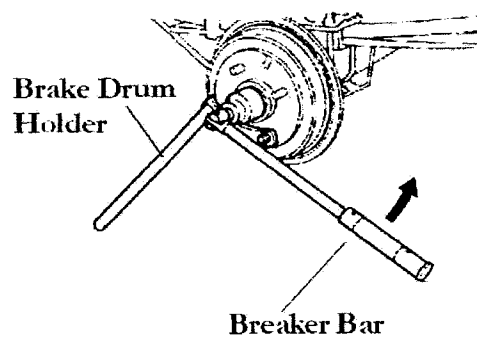

Authors Note: If Brake Drum Holder Tool is Not Available Have a Assistant Hold Brake Pedal. Do Not Use Parking Brake, it Can Slip

Axel

Rear Axel Removal

6. Use Slide Hammer and Screw On Attachment, Pull Axel

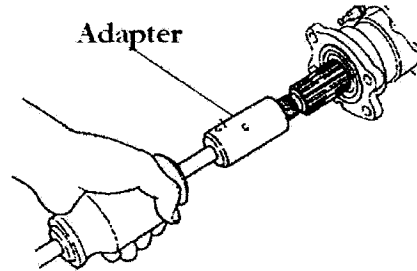

7. Use a Press and Press Off Wheel Bearing

Note: Bearing Can Not be Re-Used

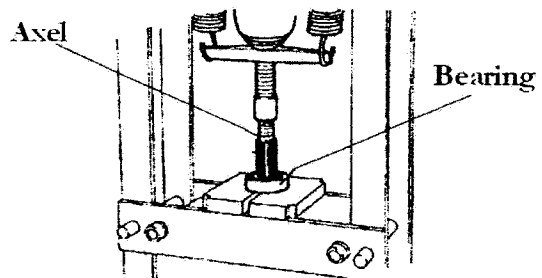

8. Use Oil Seal Puller and Slide Hammer to Pull Out Oil Seal

Note: Oil Seal Can Not be Re-Used

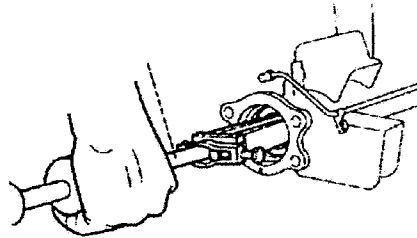

9. Inspect Rear Axel for Chips or Missing Gear Teeth.

Note: Axel Can Not Be Repaired, Any Defects Unit Must be Replaced.

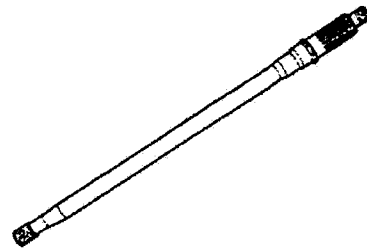

Assembly

10. Install New Oil Seal in Housing
Use Adapter: #09309-87201-000

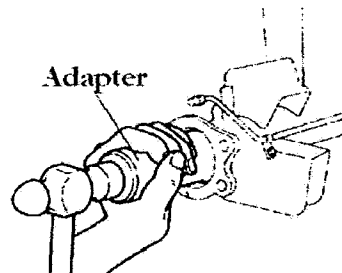

Axel

Rear Axel Installation

11. Use a Press and Press On New Bearing

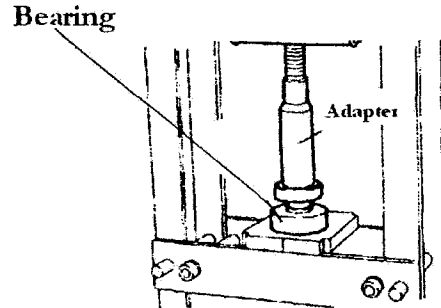

12. Install New Gasket and Axel
13. Torque Back Plate: 400+-100kg.cm

Gasket

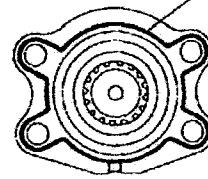

Note: Before Shaft Installation Coat With Axel Grease

14. Make Sure Grease Applied to Area Noted on Right

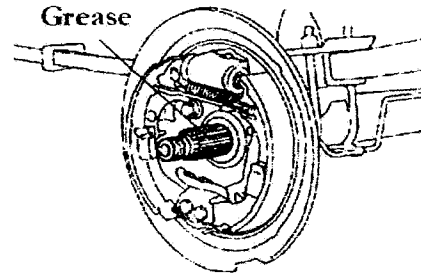

15. Attach Drum, Castle Nut, and Set Torque
Torque: 2200+-400kg.cm

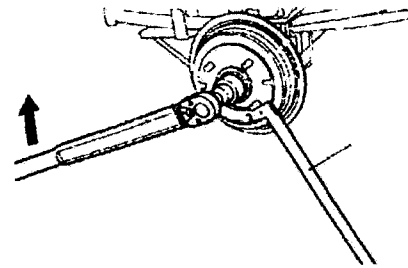

16. Attach New Cotter Pin
17. Check Oil Level. SAE90W Max: 1.3 Liters
18. Test

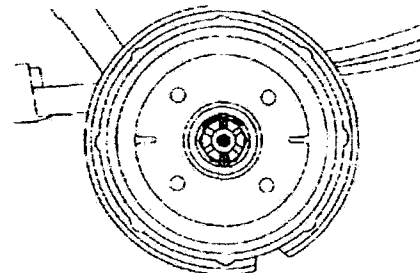

Axel

Front Axel Including ABS Vehicle 4WD

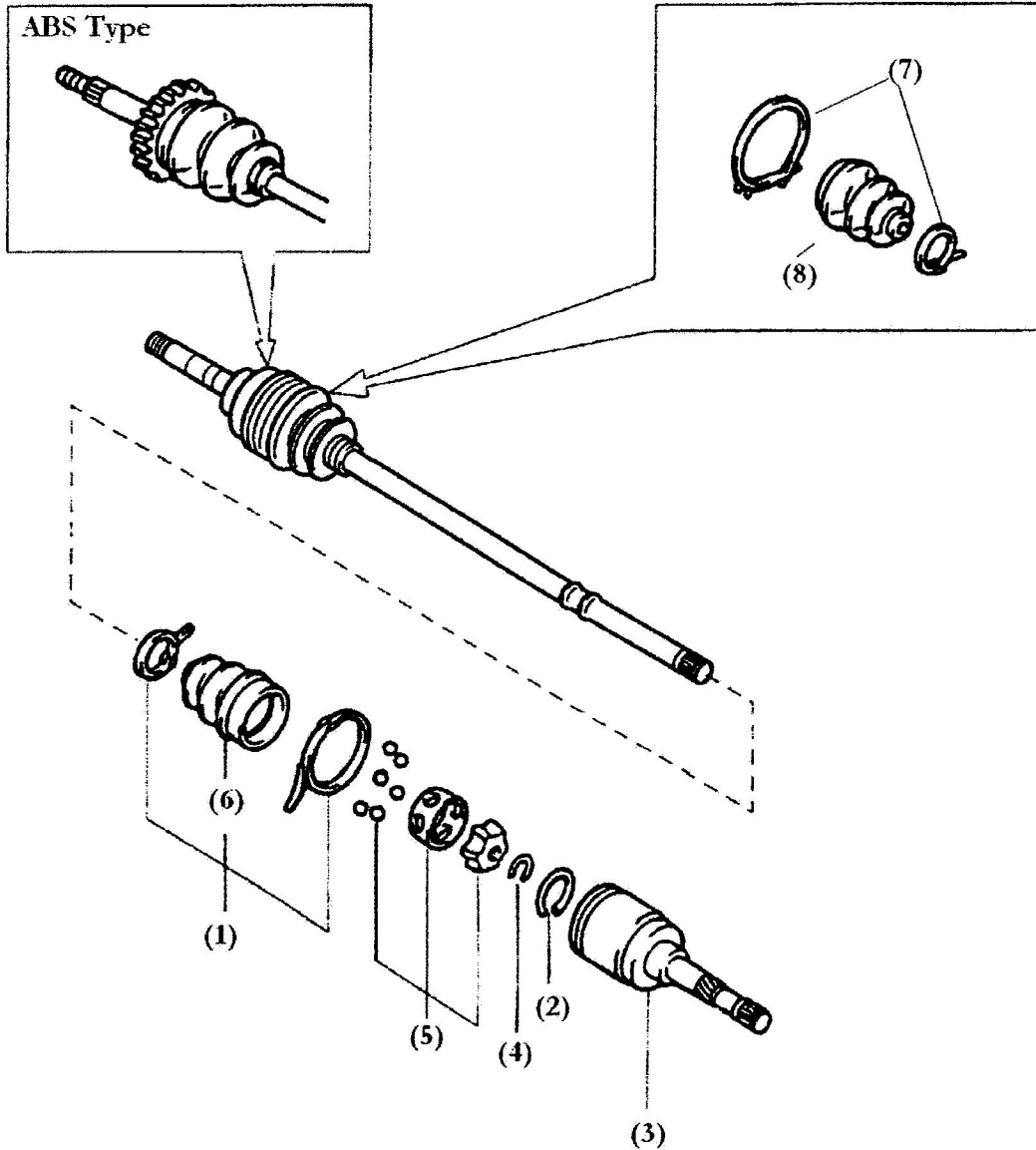

1. Boot Attachment Bands
2. Circle Clip
3. DOJ Assembly
4. Snap Ring
5. Ball Retainer Cage Assembly
6. Boot
7. Boot Bands
8. Boot

Axel

Front Axel Rebuild

Note: Wrap Axel With Shop Towel and Place in Vise. Do Not Over-Tighten

1. Use (-) Screwdriver and Un-Clip Boot Bands.
2. Remove All Old Grease

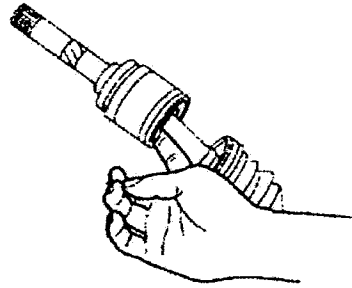

3. Use (-) Screwdriver and Remove Retainer Clip

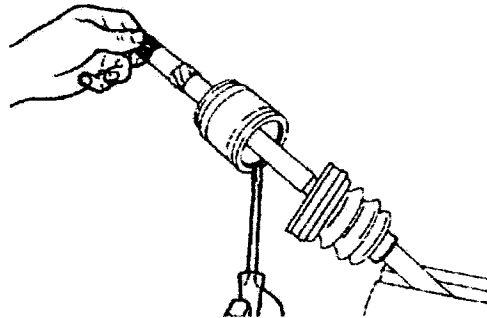

4. Slide Off DOJ

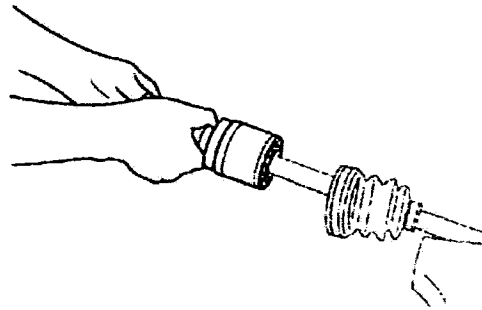

5. Remove Snap Ring

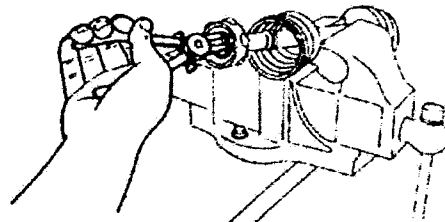

Axel

Front Axel Rebuild

6. Attach Service Tool #09950-20017-000

7. Remove Cage Bearing Assembly

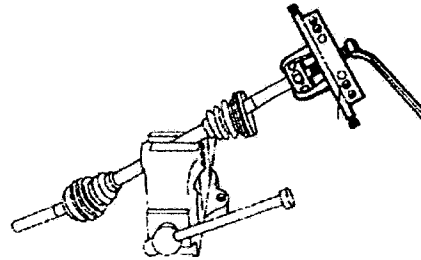

**Note: Place Piece of Tape Over Shaft End and Grease
This Protects Shaft End & Makes for Easy Disassembly
and Assembly of Boots**

8. Slide Off Boot

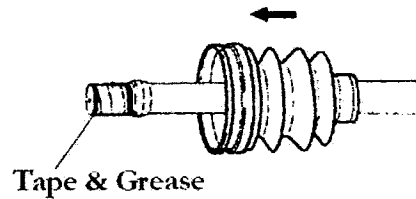

Inspection

1. Inspect Cage & Bearing Balls for Scratches or Other Damage. If Defects Detected Replace Entire Unit

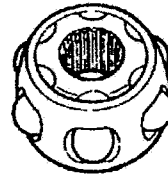

**Note: Unit Can Not be Repaired and Must be Replaced
as an Assembly**

Inspect Here

2. Examine Shaft Ends and Boots for Cracks or Excessive Wear. Replace Shaft if Teeth are Worn or Missing. Boots Generally are Replaced if Over 30,000 Kilometers. Boots Must be Changed for Over 80,000 Kilometers

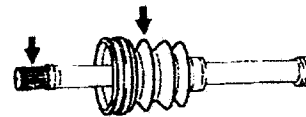

Examine Closely

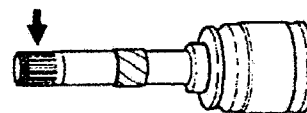

Axel

Front Axel Rebuild

Assembly

1. Test Old Bands for Operation. Use Diagram on Right

Note: Best Practice to Use New Bands

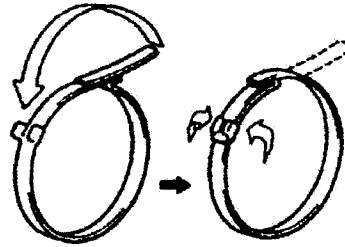

2. Tape Cage Bearing Onto Shaft

Note: Make Sure Shaft Is Greased Before Taping on Bearing

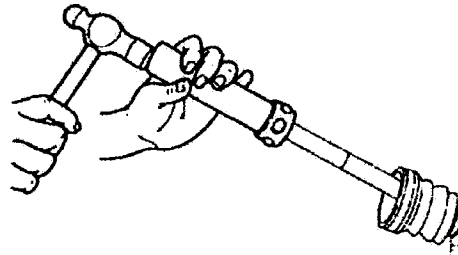

3. Attach Snap Ring

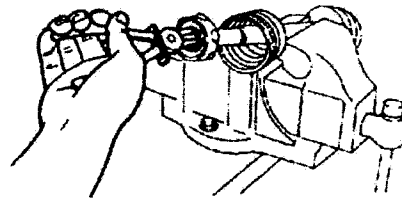

4. Attach C-Clip
5. Pack Boots with Minimum 65grams Of High Temp Long Life CV Joint Grease

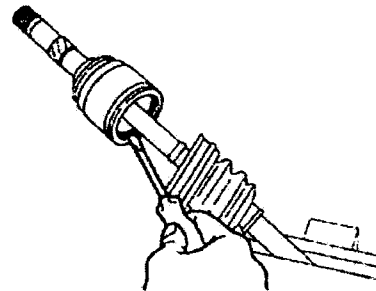

6. Attach Boot Bands
7. Install to Vehicle

Driveshaft

Parts

(B)=Bolt

(W)=Washer

(N)=Nut

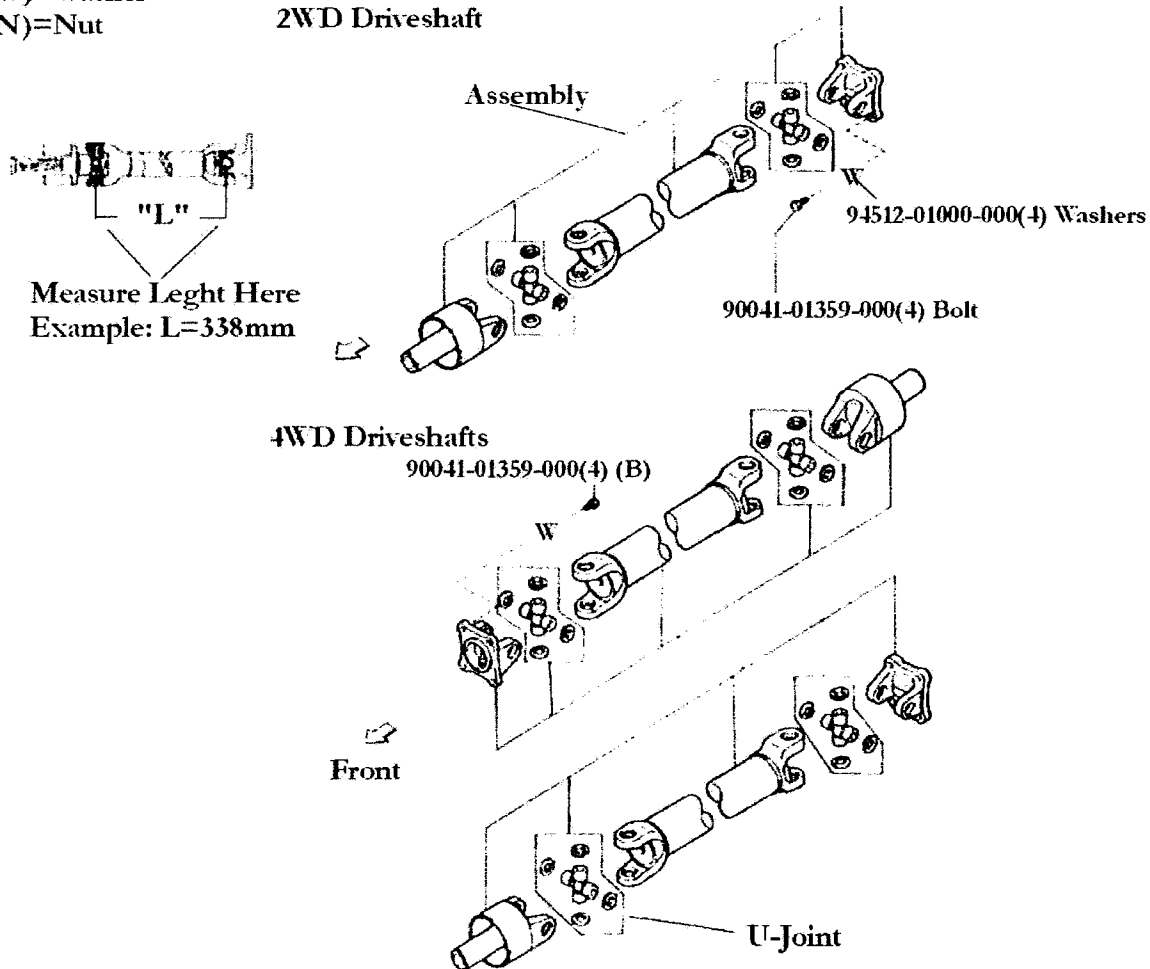

Note: Only Complete Assembly Units Available

L=Length

REAR Driveshaft:

S100 EFNS EFES (MTM, TR, MT)	# 37110-87D07-000	L=338mm
S110 (MT, DUMP, PS2 +S1, THDE	#37110-87D08-000	L=396mm
S100, S120 EFNS EFES (Van) MT	# 37110-87D11-000	L=633mm
S100, S120 EFES (Van) AT	#37110-87D12-000	L=691mm
S110 MTM (MT,DMP, NGD	#37110-87D10-000	L=194mm
S100 MTM (TR, MT)	#37110-87D07-000	L=336mm

4WD FRONT Driveshafts

S110 DMP +S110P	#37140-87526-000	L=873mm
S110, S120 VAN...PS1	#37140-87527-000	L=580
TRUCKS (Other)	#37140-97501-000	L=873mm

Note: Confirm Driveshaft Length of Your Vehicle Before Ordering

Front Axel

Front Axel Hub Parts

2WD

Castle Nut#90041-71053-000(1)

Wheel Bearing(s)

2WD Hub

All #43431-87503-000 (Non ABS)

ABS #43401-87502-000

4WD

Front

(A33) Rear Oil Seal

Oil Seal

Disk (Brake)

Wheel Bearing(s)

Castle Nut#90041-71053-000(1)

Hub

Front

Wheel Bearing

(All) #90043-63221-000

Front Hub Stud

(All) #90049-1230-000 (8) L=35mm, M12 P=1.5

Oil Seal

(All) #90043-11202-000 (2)

4WD (#A33) Oil Seal

(S110,S130) #90043-11201-000

(All Others) #90043-11307-000

4WD Hub

(ALL) (L&R) #43502-87211-000 (Non-ABS)

(ABS Only) #43502-87210-000

Disk: Front Brake (All) #43512-87521-000

Front Axel

Front Axel Parts

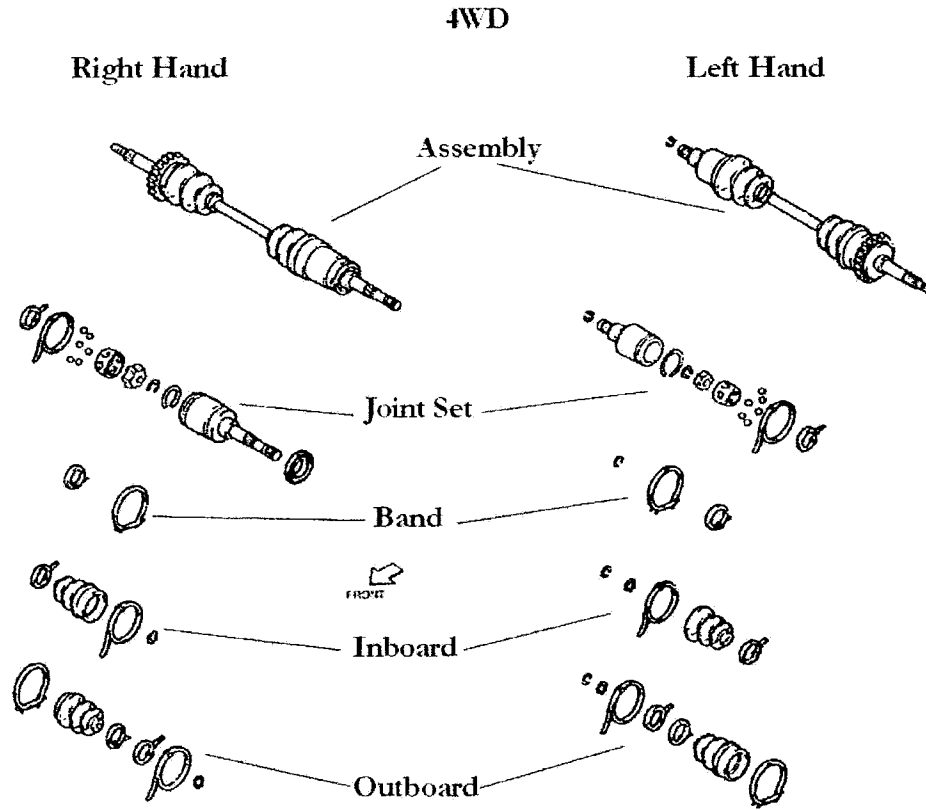

Joint Set

Left Hand (All) #43404-87591-000

Right Hand (All) #43404-87592-000

Band Set

(All) #04438-87518-000

Boot Set: Inboard

(All) #04438-87514-000

Boot Set: Outboard

(All) #04438-87521-000

Note: Full Assembly Not Available

Rear Axel

Rear Axel Parts

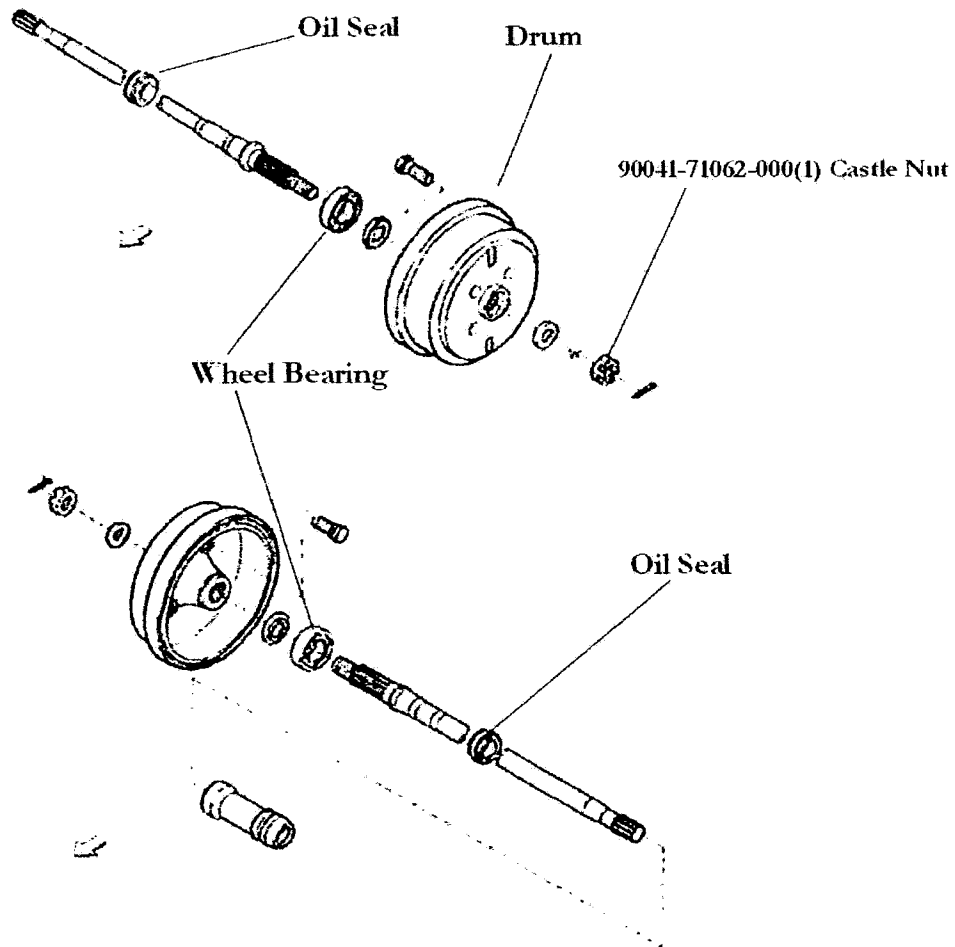

Note: Only Available Parts Listed Below

Oil Seal
(All) #90043-11312-000

Rear Brake Drum
S100, S110, S120, S130 #42403-87514-000
S140 #42403-87516-000
S120, S130 (TBO) ABS #42403-87515-000

Stud Bolts
(All) #90049-12044-00

Bearing: Wheel
S110, S130 #90043-63230-000
S100, S120, S140 #90043-63236-000

Chapter 12

Clutch System

- **Transmission Identification 2WD & 4WD**
- **Clutch Cable System and Replacement**
- **Clutch Specialty Tools**
- **Clutch Pressure Plate & Clutch Disk Replacement**
- **Parts**

Transmission Identification

Manual Transmission

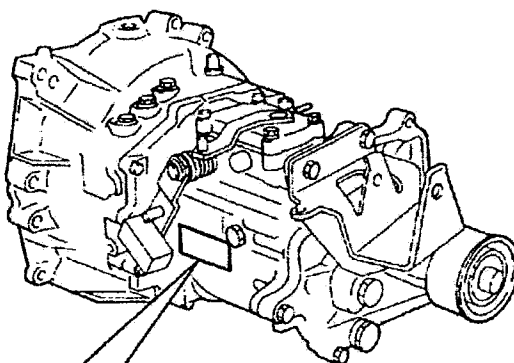

Example: 214=2WD Non-Turbo Van

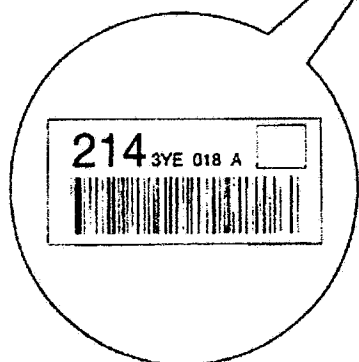

Drivetrain	Type	Mark
2WD	Truck/Van	213
2WD	Atraí	214
2WD Turbo	Atraí	220
4WD PT 4WD	Truck/Van	P19 H-L
4WD Normal	Truck/Van	P10
4WD PT 4WD	Truck	P11 PTO
4WD PT 4WD	Van	P12
4WD PT 4WD	Truck/Van	P20
4WD Turbo	PTO Option	P28
4WD Turbo Muti Select 4WD		A20

Clutch System

Clutch Cable

Components

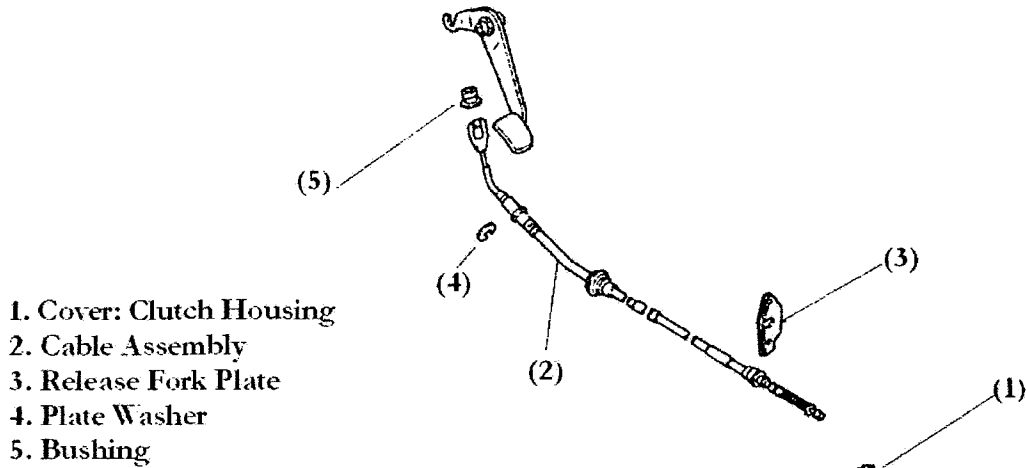

Replacement & Adjustment

1. Remove Clutch Housing Cover (Dust)
2. Remove Cable Clamp

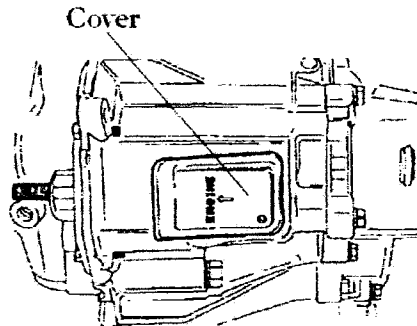

3. Back Off Adjustment Nut (Left) and Pull Forward
4. Disconnect Cable From Fork

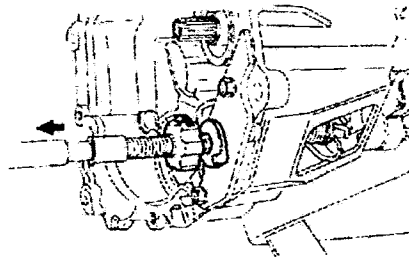

Clutch System

Clutch Cable Removal

5. Remove The Two Retainer Bolts Shown on Right Diagram

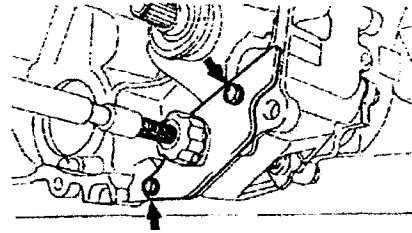

6. Lift Up on Clutch Pedal and Remove Cable

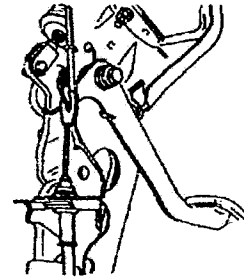

7. Un-Lock Clip as in Diagram on Right
Note: Some Models Do Not Have This Feature

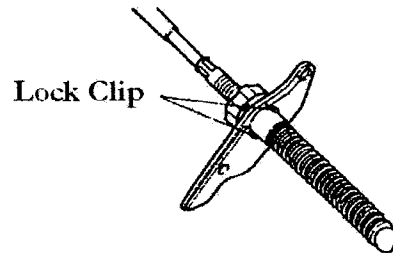

Installation

1. Check New Cable For Free Travel

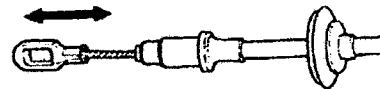

2. Attach Cable to Pedal Assembly
3. Run Cable to Transmission

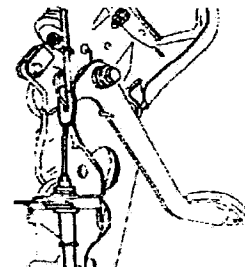

Clutch System

Cable Assembly & Adjustment

4. Set Lock Clip And Slide Cable Unit Into Housing

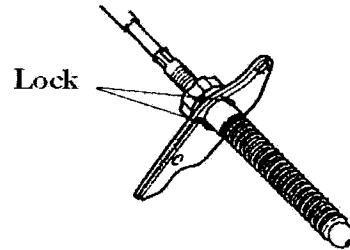

5. Attach Cable to Fork
6. Attach Retaining Bolts as in Diagram on Right
7. Attach Cable Retaining Clamp

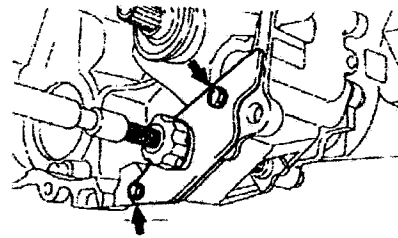

8. Attach Cluth Housing Dust Cover

9. Set Cable Free Play
Limit: 15~25mm
Clutch Pedal Deck Height
Limit: 139~149mm

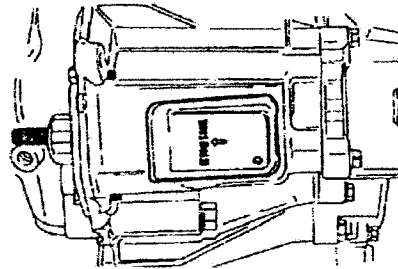

Clutch System

Clutch Specialty Tools

Flywheel Holder

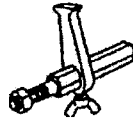

#09210-87701-000

Clutch Guide

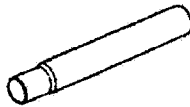

#09301-87501-000

Height Gage

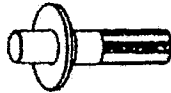

#09302-87701-000

Alignment Tool



#09333-00013-000

Clutch Cetering Tool



#999-08440-W9-023

Clutch System

Clutch Replacement

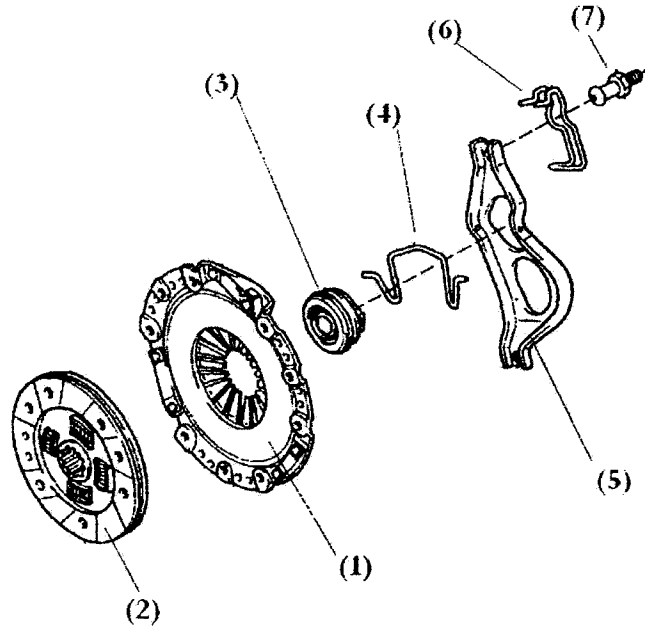

1. Pressure Plate
 2. Clutch Disk
 3. Bearing
 4. Bearing Retainer
 5. Clutch Fork
 6. Spring: Release Fork
 7. Pivot Support
-

Replacement

1. Remove Transmission
2. Attach Flywheel Holder Tool and Remove (6) Pressure Plate Retaining Bolts
3. Remove Pressure Plate and Clutch Disk

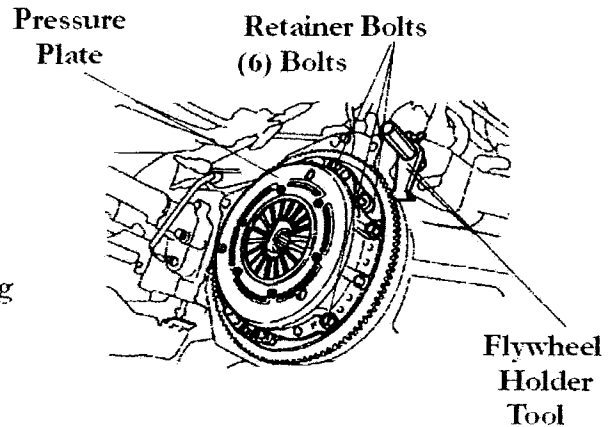

Clutch System

Clutch Inspection

4. Attach Dial Gage as in Diagram on Right and Check Flywheel Round-Out

Limit: 0.10mm

Note: Inspect Flywheel Ring Gear Teeth. If Teeth Are Missing or Worn Replace

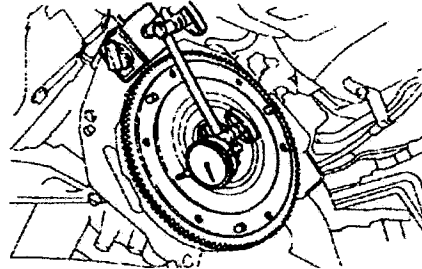

Clutch Disk Inspection

Note: Skip Step If New Disk to be Installed

5. Measure Rivet Depth

Limit: 0.3mm

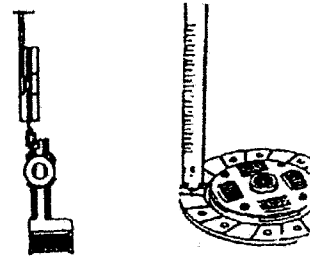

Clutch Disk Round-Out Limit: 1.0mm

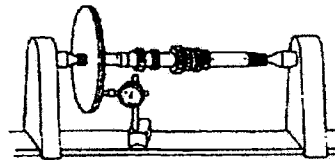

6. Release Bearing: Check for Free Spin. Any Binding Replace Unit. Unit Must be Replace Every 80,000 Kilometers

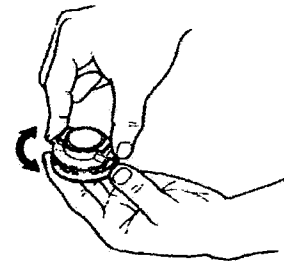

Note: Never Clean Bearing With Solvant

Installation

1. Replace or Install Release Bearing and Grease as Noted on Right

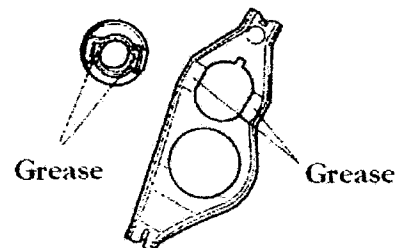

Use High Temp-Long Life Chassis Grease

Clutch System

Clutch Installation

2. Attach Release Bearing Hub Clip to Release Fork as in Diagram to Right

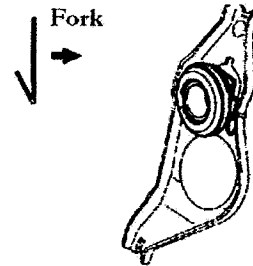

3. Inspect Pivot Point (Replace if Worn) and Apply Grease

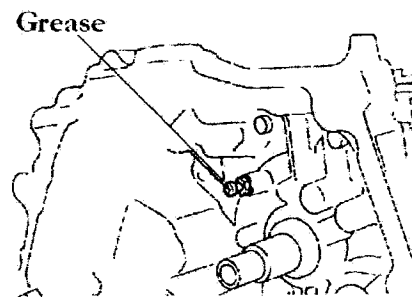

4. Attach Release Fork Assembly as in Diagram to Right

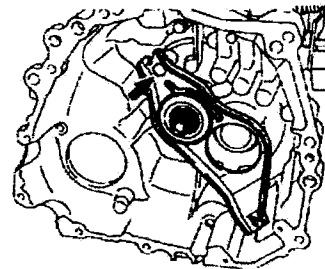

5. Apply 0.2grams of Grease to Center Spline as in Diagram. Do Not Get Grease On Disk Friction Plates.

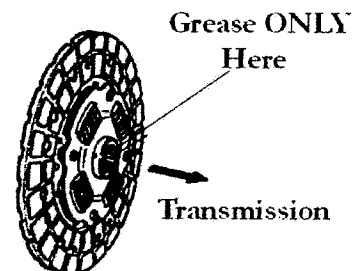

6. Use Alignment Tool And Line Up Disk

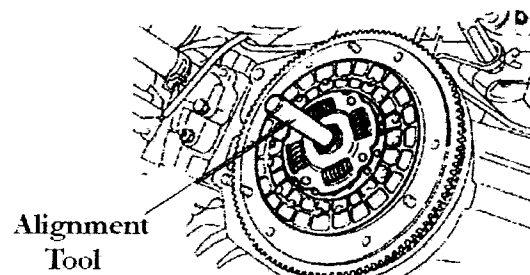

Clutch System

Clutch Assembly & Parts

7. Attach Pressure Plate Over Clutch Disk and Place Alignment Tool Between

8. Install (6) Pressure Plate Attachment Bolts and Torque in Order Lited Below

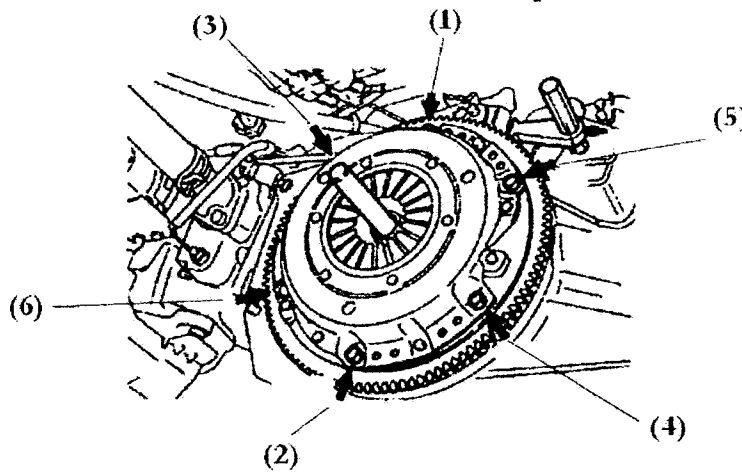

Torque Order

9. Torque Pressure Plate Bolts to T: 185+-35kg.cm

10. Remove Alignment Tool

11. Install Transmissiom

Parts

Release Bearing Retainer Clip (All) #31232-87505-000

Release Bearing (All) #31230-87507-000 or #31230-97501-000

Pressure Plate

S120, S130 OVZM #31210-87237-000

S100, S110, S120, S130, S140 #31210-87526-000

Clutch Disk

(Universal) #31250-87560-000

