

CHARGING SYSTEM

CH013-01

PRECAUTION

- ◆ Check that the battery cables are connected to the correct terminals.
- ◆ Disconnect the battery cables when the battery is given a quick charge.
- ◆ Do not perform tests with a high voltage insulation resistance tester.
- ◆ Never disconnect the battery while the engine is running.

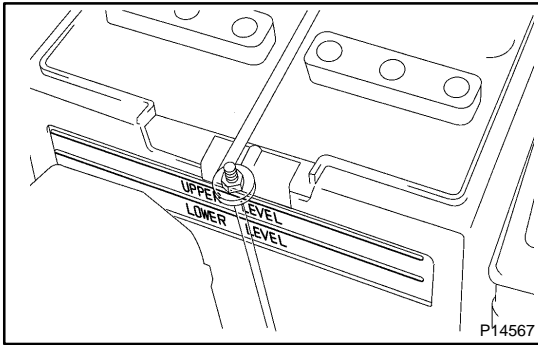

ON-VEHICLE INSPECTION

1. CHECK BATTERY ELECTROLYTE LEVEL

Check the electrolyte quantity of each cell.

Maintenance-Free Battery:

If under the lower level, replace the battery (or add distilled water if possible). Check the charging system.

Except Maintenance-Free Battery:

If under the lower level, add distilled water.

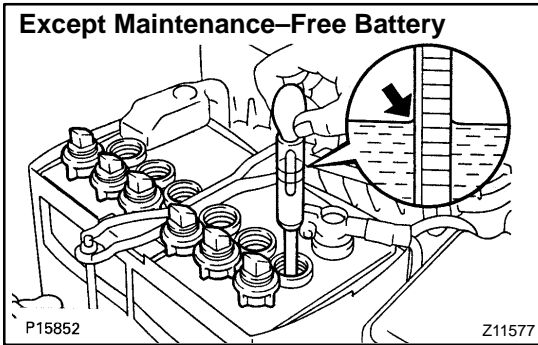

2. Except Maintenance-Free Battery: CHECK BATTERY SPECIFIC GRAVITY

Check the specific gravity of each cell.

Standard specific gravity: 1.25 – 1.29 at 20°C (68°F)

If the specific gravity is less than specification, charge the battery.

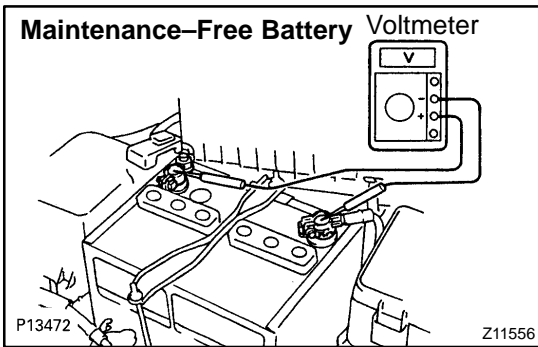

3. Maintenance-Free Battery: CHECK BATTERY VOLTAGE

(a) After having driven the vehicle and in the case that 20 minutes have not passed after having stopped the engine, turn the ignition switch ON and turn on the electrical system (headlight, blower motor, rear defogger etc.) for 60 seconds to remove the surface charge.

(b) Turn the ignition switch OFF and turn off the electrical systems.

(c) Measure the battery voltage between the negative (-) and positive (+) terminals of the battery.

Standard voltage: 12.5 – 12.9 V at 20°C (68°F)

If the voltage is less than specification, charge the battery.

HINT:

Check the indicator as shown in the illustration.

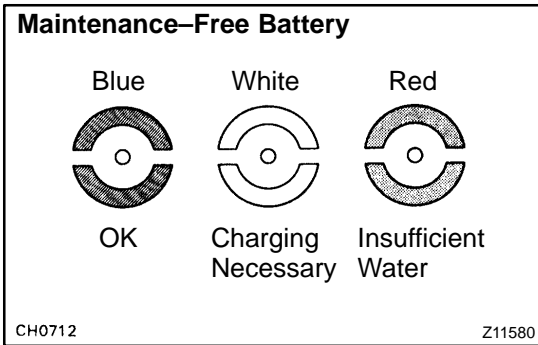

4. CHECK BATTERY TERMINALS, FUSIBLE LINK AND FUSES

(a) Check that the battery terminals are not loose or corroded.

If the terminals are corroded, clean the terminals.

(b) Check the fusible link, H-fuses, M-fuse and fuses for continuity.

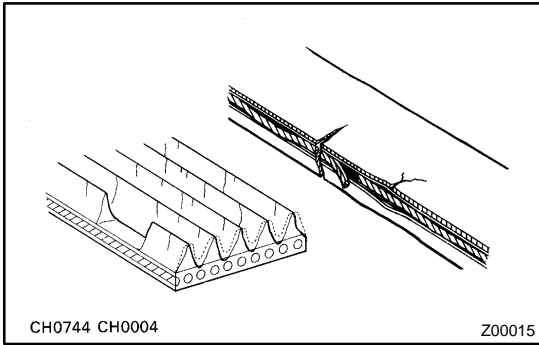

5. INSPECT DRIVE BELTS

- (a) Visually check the drive belt for excessive wear, frayed cords etc.

If any defect has been found, replace the drive belt.

HINT:

Cracks on the rib side of a drive belt are considered acceptable. If the drive belt has chunks missing from the ribs, it should be replaced.

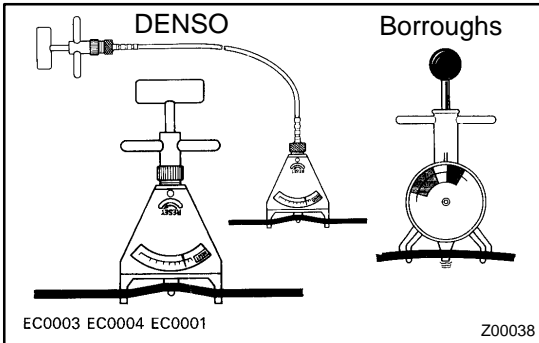

- (b) Using a belt tension gauge, measure the belt tension.

Belt tension gauge:

DENSO BTG-20 (95506-00020)

Borrourghs No. BT-33-73F

Drive belt tension:

New belt: 175 ± 5 lbf

Used belt: 115 ± 20 lbf

If the belt tension is not as specified, adjust it.

HINT:

- ◆ "New belt" refers to a belt which has been used less than 5 minutes on a running engine.
- ◆ "Used belt" refers to a belt which has been used on a running engine for 5 minutes or more.
- ◆ After installing a belt, check that it fits properly in the ribbed grooves.
- ◆ Check with your hand to confirm that the belt has not slipped out of the groove on the bottom of the pulley.
- ◆ After installing a new belt, run the engine for about 5 minutes and recheck the belt tension.

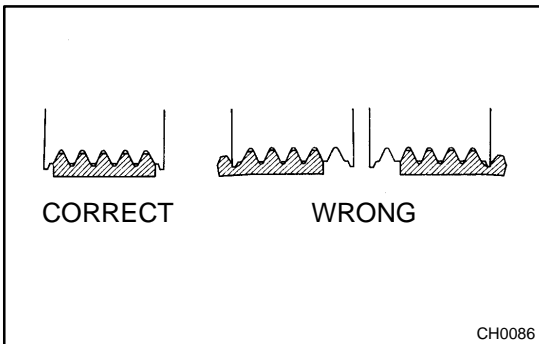

6. VISUALLY CHECK GENERATOR WIRING AND LISTEN FOR ABNORMAL NOISES

- (a) Check that the wiring is in good condition.
- (b) Check that there is no abnormal noise from the generator while the engine is running.

7. CHECK DISCHARGE WARNING LIGHT CIRCUIT

- (a) Warm up the engine and then turn it off.
- (b) Turn off all accessories.
- (c) Turn the ignition switch "ON". Check that the discharge warning light is lit.
- (d) Start the engine. Check that the light goes off.

If the light does not go off as specified, troubleshoot the discharge light circuit.

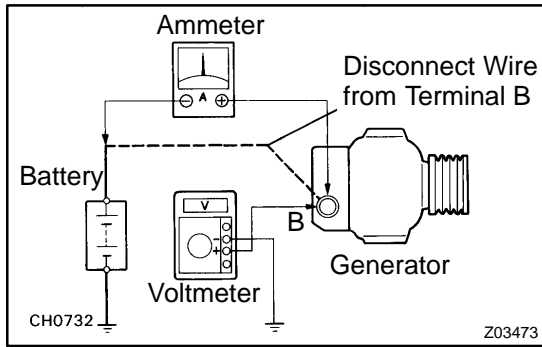

8. INSPECT CHARGING CIRCUIT WITHOUT LOAD

HINT:

If a battery/generator tester is available, connect the tester to the charging circuit as per manufacturer's instructions.

- (a) If a tester is not available, connect a voltmeter and ammeter to the charging circuit as follows:
- ◆ Disconnect the wire from terminal B of the generator, and connect it to the negative (–) tester probe of the ammeter.
 - ◆ Connect the positive (+) tester probe of the ammeter to terminal B of the generator.
 - ◆ Connect the positive (+) tester probe of the voltmeter to terminal B of the generator.
 - ◆ Ground the negative (–) tester probe of the voltmeter.
- (b) Check the charging circuit as follows:
With the engine running from idling to 2,000 rpm, check the reading on the ammeter and voltmeter.

Standard amperage: 10 A or less

Standard voltage: 13.2 – 14.8 V

If the voltmeter reading is more than standard voltage, replace the voltage regulator.

If the voltmeter reading is less than standard voltage, check the voltage regulator and generator as follows:

- ◆ With terminal F grounded, start the engine and check the voltmeter reading of terminal B.
- ◆ If the voltmeter reading is more than standard voltage, replace the voltage regulator.
- ◆ If the voltmeter reading is less than standard voltage, check the generator.

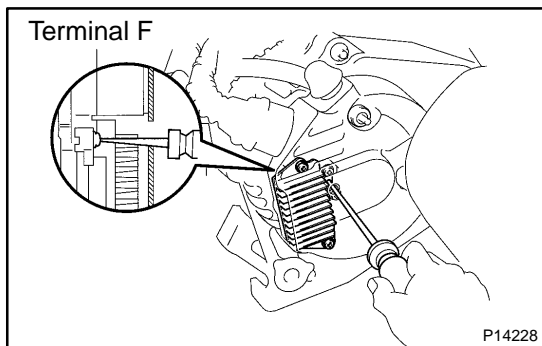

9. INSPECT CHARGING CIRCUIT WITH LOAD

- (a) With the engine running at 2,000 rpm, turn on the high beam headlights and place the heater blower switch at "HI".
- (b) Check the reading on the ammeter.

Standard amperage: 30 A or more

If the ammeter reading is less than the standard amperage, repair the generator.

HINT:

If the battery is fully charged, the indication will sometimes be less than standard amperage.

GENERATOR COMPONENTS

CH015-01

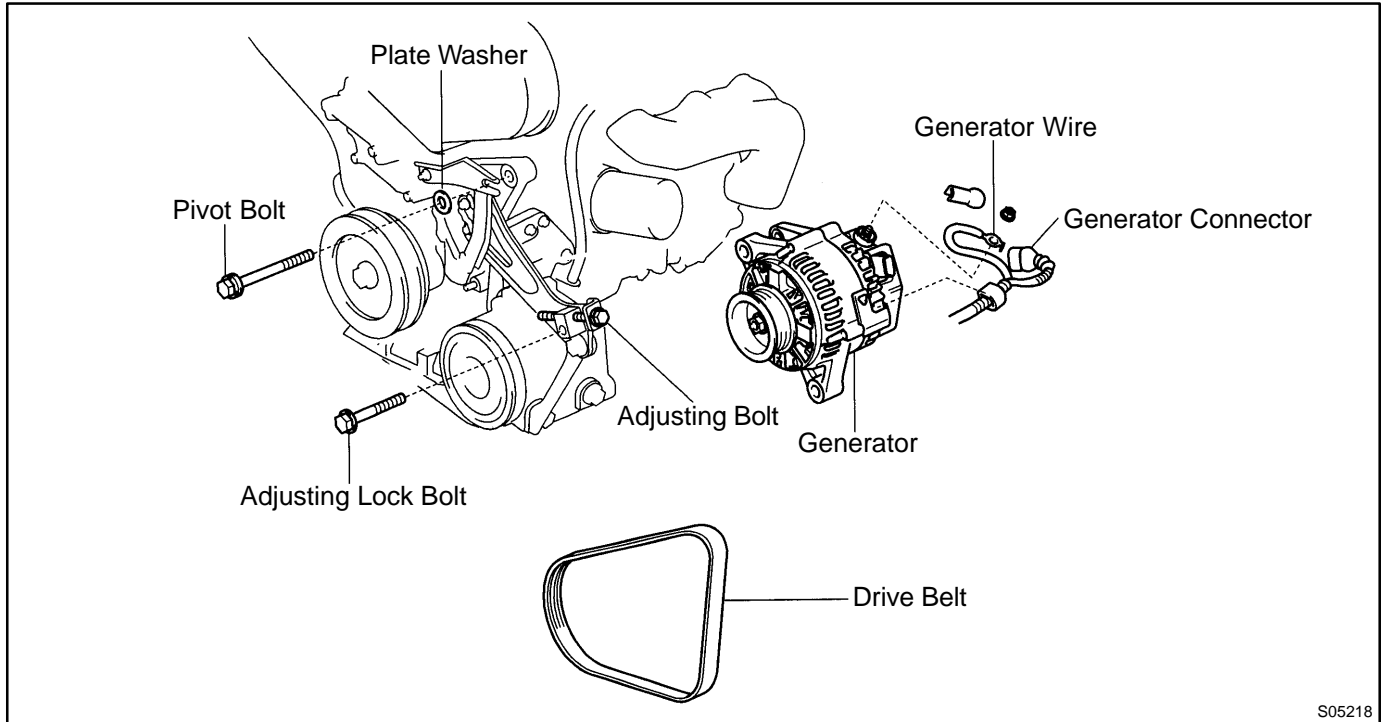

S05218

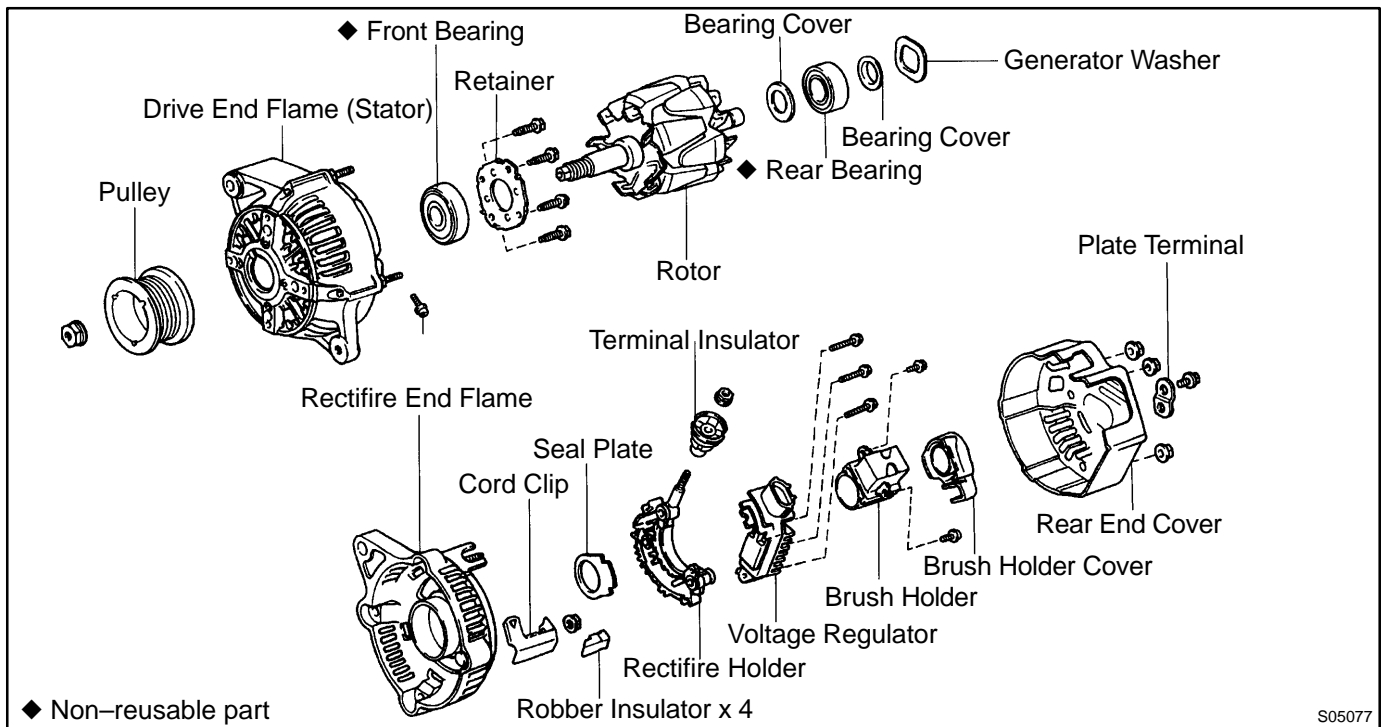

S05077

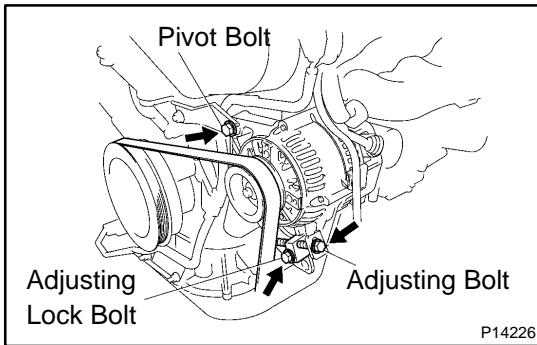

REMOVAL

1. REMOVE DRIVE BELT

Loosen the pivot bolt, adjusting lock bolt and adjusting bolt, and remove the drive belt.

Torque:

Pivot bolt: 56 N·m (570 kgf·cm, 41 ft·lbf)

Lock bolt: 18 N·m (180 kgf·cm, 13 ft·lbf)

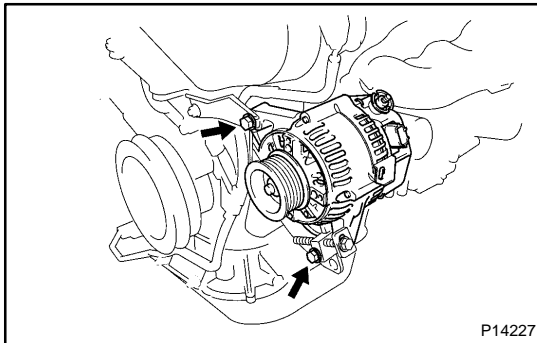

2. REMOVE GENERATOR

- (a) Disconnect the generator connector.
- (b) Remove the nut, and disconnect the generator wire.
- (c) Disconnect the wire harness from the clip.
- (d) Remove the pivot bolt, plate washer, adjusting lock bolt and generator.

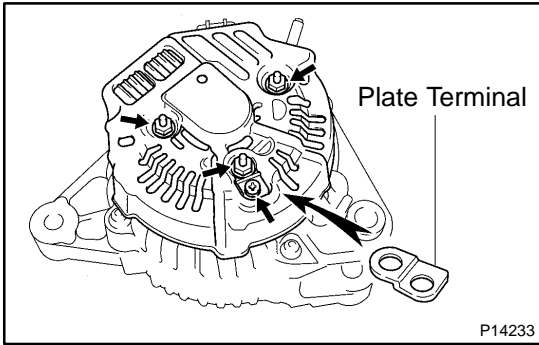

DISASSEMBLY

1. REMOVE REAR END COVER

- (a) Remove the nut and terminal insulator.
- (b) Remove the screw, 3 nuts, plate terminal and end cover.

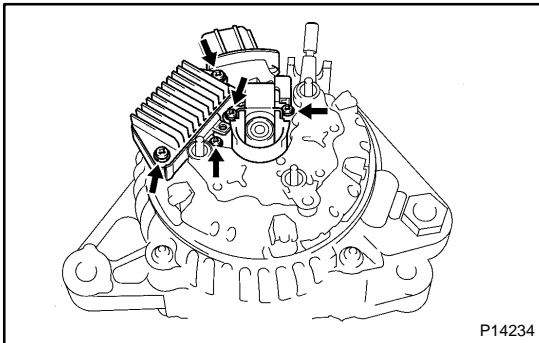

2. REMOVE BRUSH HOLDER AND VOLTAGE REGULATOR

- (a) Remove the brush holder cover from the brush holder.
- (b) Remove the 5 screws, brush holder and voltage regulator.

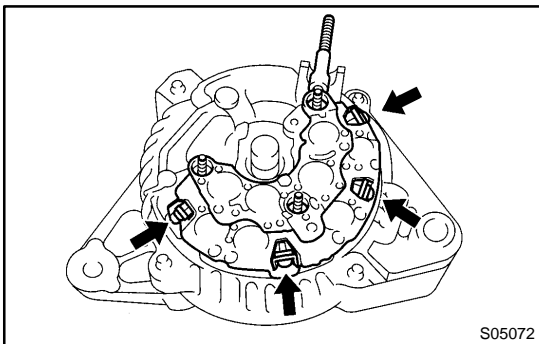

3. REMOVE RECTIFIER HOLDER

- (a) Remove the 4 screws and rectifier holder.
- (b) Remove the 4 rubber insulators.
- (c) Remove the seal plate.

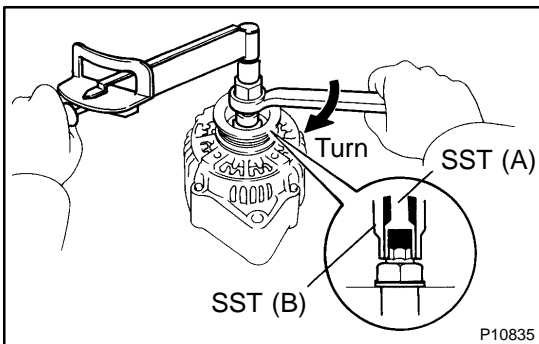

4. REMOVE PULLEY

- (a) Hold SST (A) with a torque wrench, and tighten SST (B) clockwise to the specified torque.

SST 09820-63010

Torque: 39 N·m (400 kgf·cm, 29 ft·lbf)

- (b) Check that SST (A) is secured to the rotor shaft.

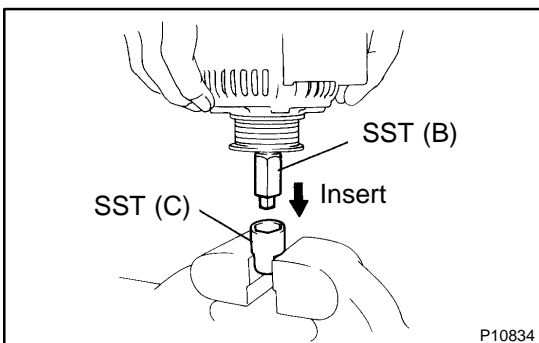

- (c) Mount SST (C) in a vise.

- (d) Insert SST (B) into SST (C), and attach the pulley nut to SST (C).

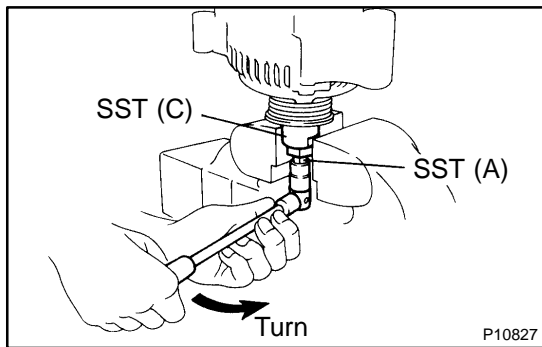

- (e) To loosen the pulley nut, turn SST (A) in the direction shown in the illustration.

NOTICE:

To prevent damage to the rotor shaft, do not loosen the pulley nut more than one-half of a turn.

- (f) Remove the generator from SST (C).

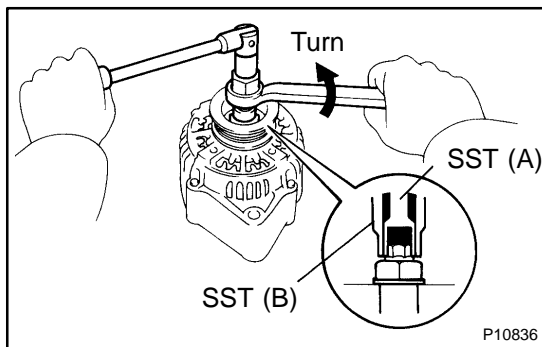

- (g) Turn SST (B), and remove SST (A and B).
 (h) Remove the pulley nut and pulley.

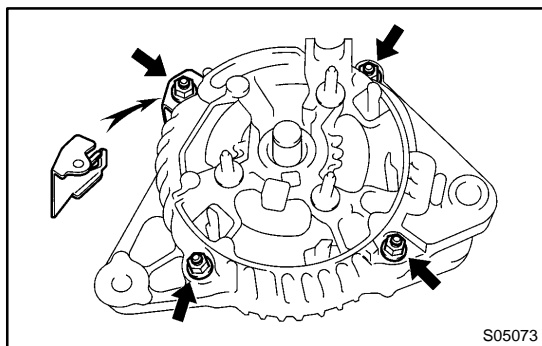

5. REMOVE RECTIFIER END FRAME

- (a) Remove the 4 nuts and cord clip.

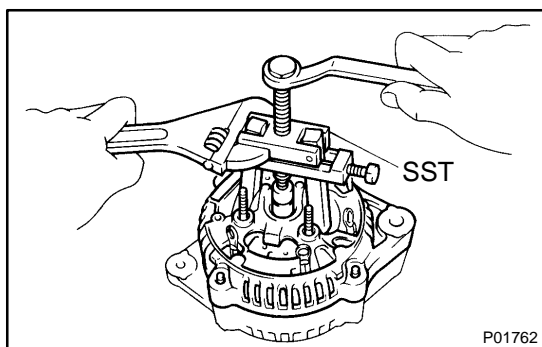

- (b) Using SST, remove the rectifier end frame.
 SST 09286-46011
 (c) Remove the generator washer.

6. REMOVE ROTOR FROM DRIVE END FRAME

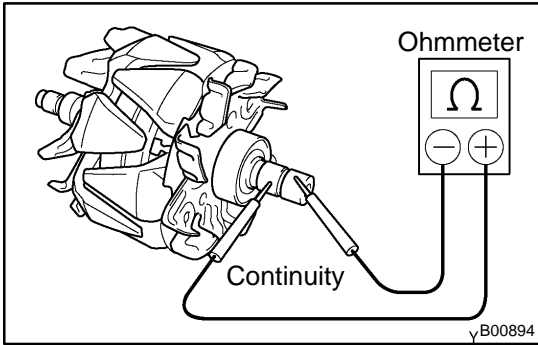

INSPECTION

1. INSPECT ROTOR FOR OPEN CIRCUIT

Using an ohmmeter, check that there is continuity between the slip rings.

Standard resistance: 2.1 – 2.5 Ω at 20°C (68°F)

If there is no continuity, replace the rotor.

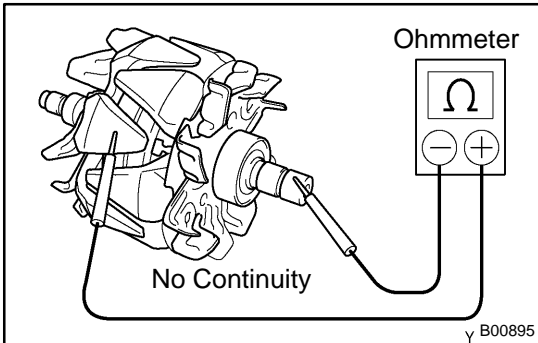

2. INSPECT ROTOR FOR GROUND

Using an ohmmeter, check that there is no continuity between the slip ring and rotor.

If there is continuity, replace the rotor.

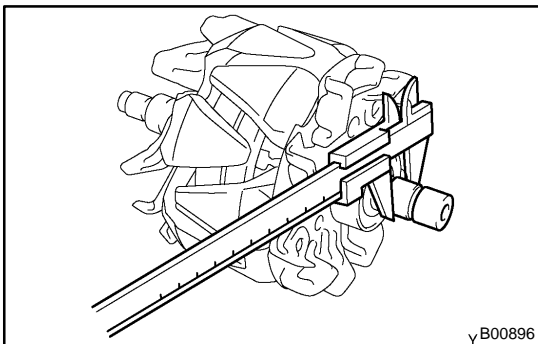

3. INSPECT SLIP RINGS

(a) Check that the slip rings are not rough or scored. If rough or scored, replace the rotor.

(b) Using a vernier caliper, measure the slip ring diameter.
Standard diameter: 14.2 – 14.4 mm (0.559–0.567 in.)
Minimum diameter: 12.8 mm (0.504 in.)

If the diameter is less than minimum, replace the rotor.

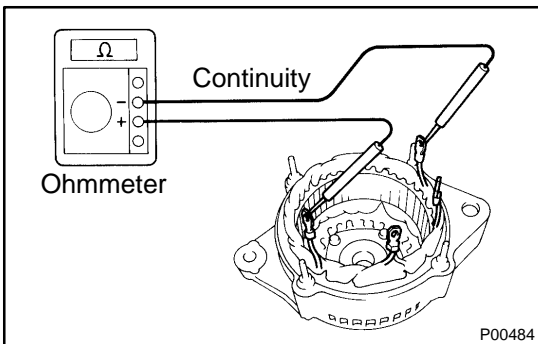

4. INSPECT STATOR FOR OPEN CIRCUIT

Using an ohmmeter, check that there is continuity between the coil leads.

If there is no continuity, replace the drive end frame assembly.

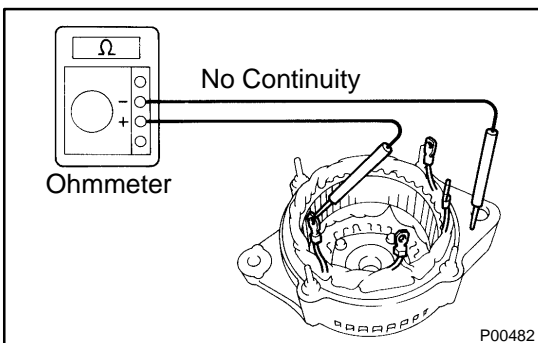

5. INSPECT STATOR FOR GROUND

Using an ohmmeter, check that there is no continuity between the coil lead and drive end frame.

If there is continuity, replace the drive end frame assembly.

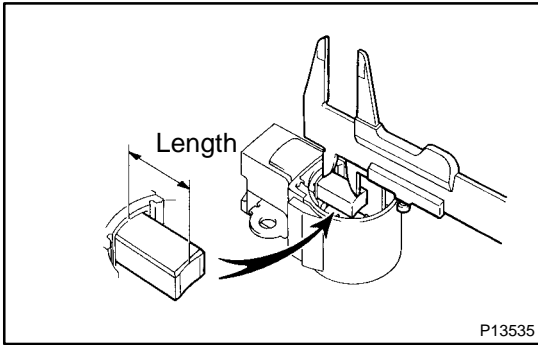

6. INSPECT EXPOSED BRUSH LENGTH

Using a vernier caliper, measure the exposed brush length.

Standard exposed length: 10.5 mm (0.413 in.)

Minimum exposed length: 1.5 mm (0.059 in.)

If the exposed length is less than minimum, replace the brushes and brush holder assembly.

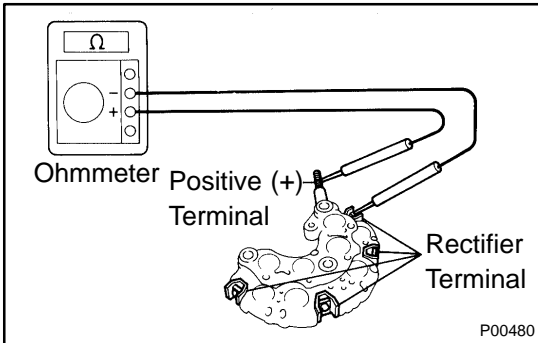

7. INSPECT POSITIVE RECTIFIER

(a) Using an ohmmeter, connect one tester probe to the positive (+) terminal and the other to each rectifier terminal.

(b) Reverse the polarity of the tester probes and repeat step (a).

(c) Check that one shows continuity and the other shows no continuity.

If continuity is not as specified, replace the rectifier holder.

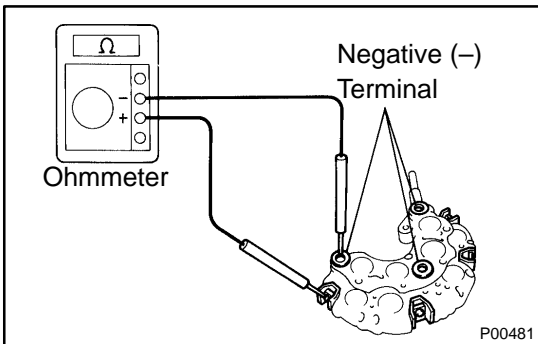

8. INSPECT NEGATIVE RECTIFIER

(a) Using an ohmmeter, connect one tester probe to each negative (-) terminal and the other to each rectifier terminal.

(b) Reverse the polarity of the tester probes and repeat step (a).

(c) Check that one shows continuity and the other shows no continuity.

If continuity is not as specified, replace the rectifier holder.

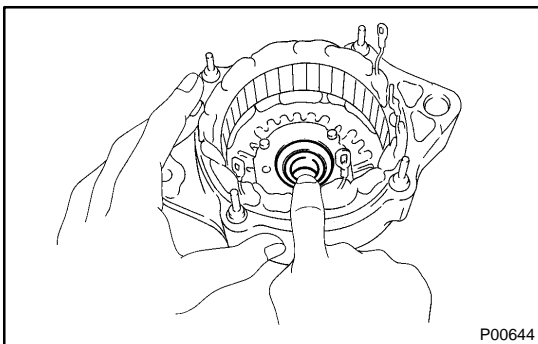

9. INSPECT FRONT BEARING

Check that the bearing is not rough or worn.

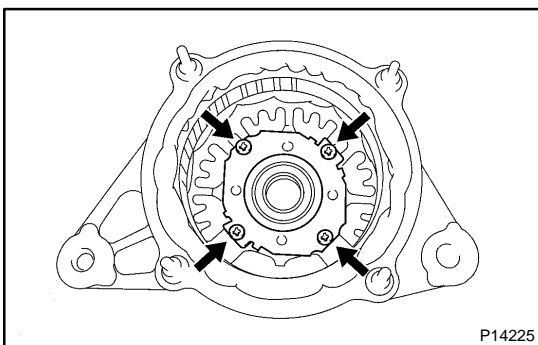

10. IF NECESSARY, REPLACE FRONT BEARING

(a) Remove the 4 screws, bearing retainer and bearing.

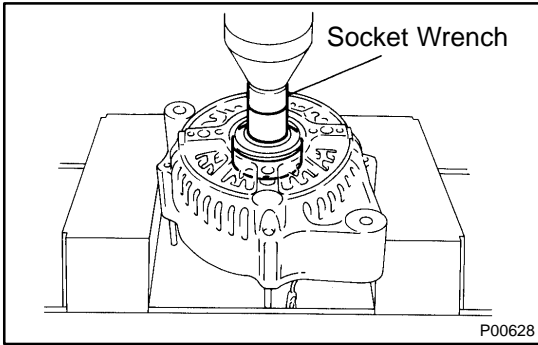

(b) Using a socket wrench and press, press out the bearing.

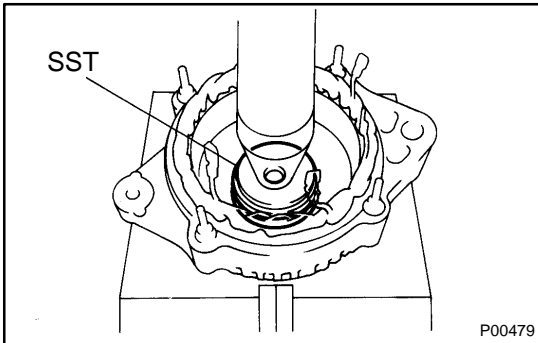

(c) Using SST and a press, press in a new bearing.
SST 09950-60010 (09951-00500)

(d) Install the bearing retainer with the 4 screws.
Torque: 3.0 N·m (31 kgf·cm, 27 in.-lbf)

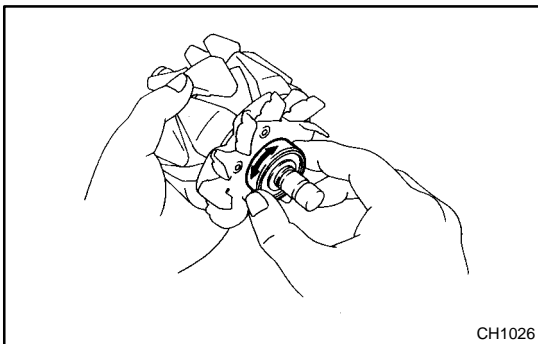

11. INSPECT REAR BEARING

Check that the bearing is not rough or worn.

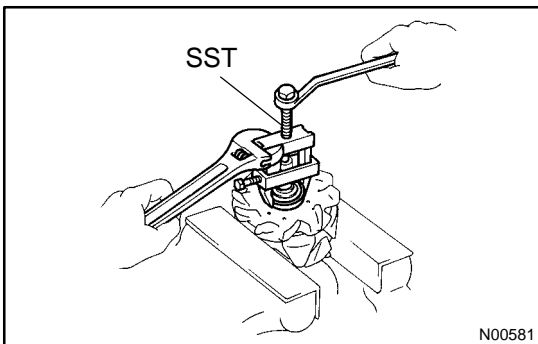

12. IF NECESSARY, REPLACE REAR BEARING

(a) Using SST, remove the bearing cover (outside) and bearing.

SST 09820-00021

NOTICE:

Be careful not to damage the fan.

(b) Remove the bearing cover (inside).

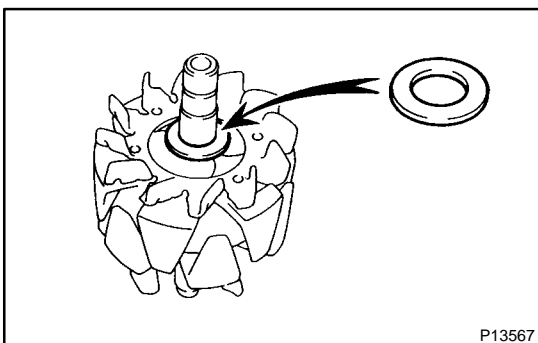

(c) Place the bearing cover (inside) on the rotor.

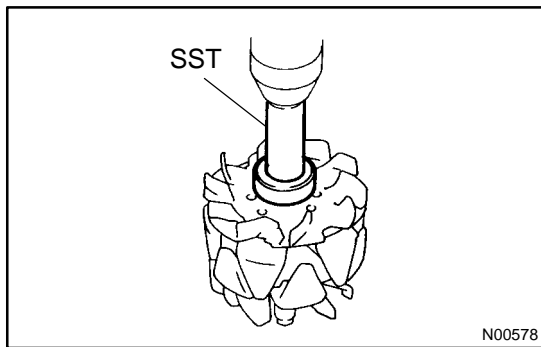

- (d) Using SST and a press, press in a new bearing.
SST 09820-00030

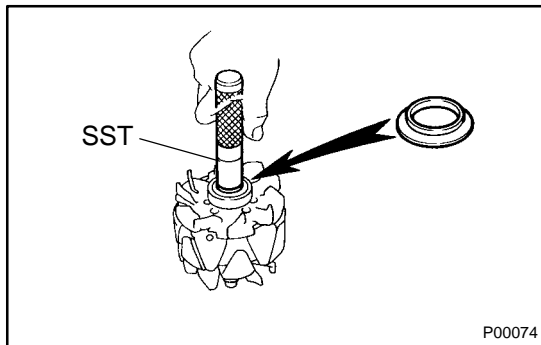

- (e) Using SST, push in the bearing cover (outside).
SST 09285-76010

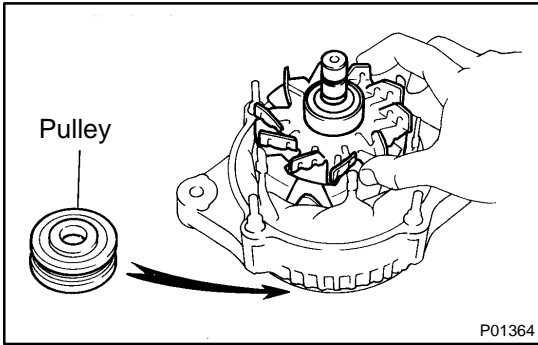

REASSEMBLY

1. INSTALL ROTOR TO DRIVE END FRAME

- (a) Place the rectifier end frame on the pulley.
- (b) Install the rotor to the rectifier end frame.

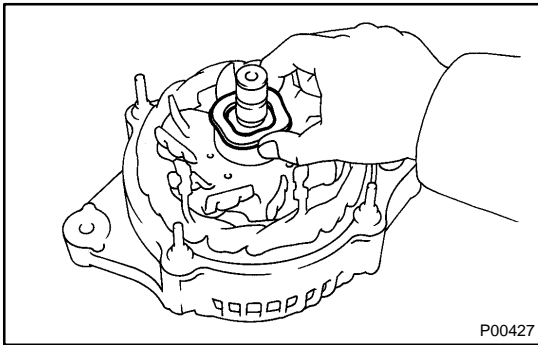

2. INSTALL RECTIFIER END FRAME

- (a) Place the generator washer on the rotor.

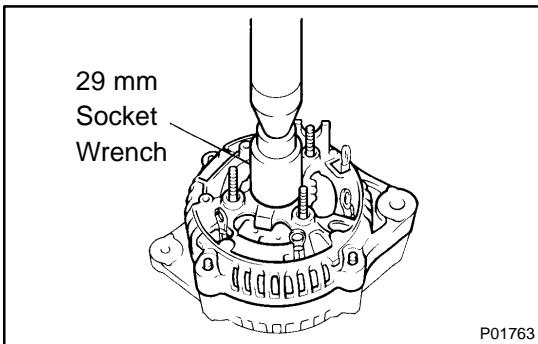

- (b) Using a 29 mm socket wrench and press, slowly press in the rectifier end frame.

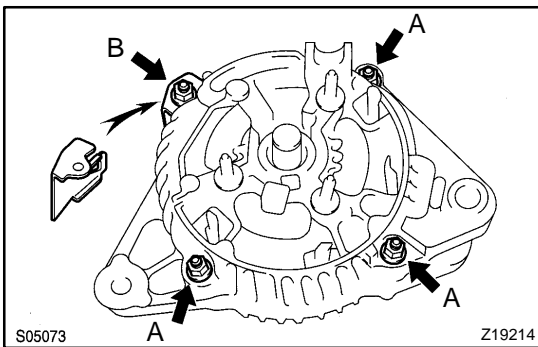

- (c) Install the cord clip with the 4 nuts.

Torque:

Nut A: 4.5 N·m (46 kgf·cm, 40 in.-lbf)

Nut B: 5.4 N·m (55 kgf·cm, 48 in.-lbf)

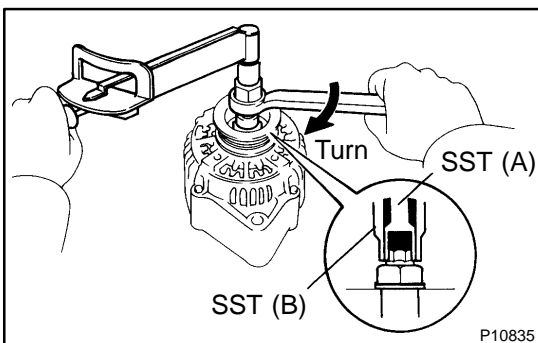

3. INSTALL PULLEY

- (a) Install the pulley to the rotor shaft by tightening the pulley nut by hand.
- (b) Hold SST (A) with a torque wrench, and tighten SST (B) clockwise to the specified torque.
SST 09820-63010
Torque: 39 N·m (400 kgf·cm, 29 ft·lbf)
- (c) Check that SST (A) is secured to the pulley shaft.

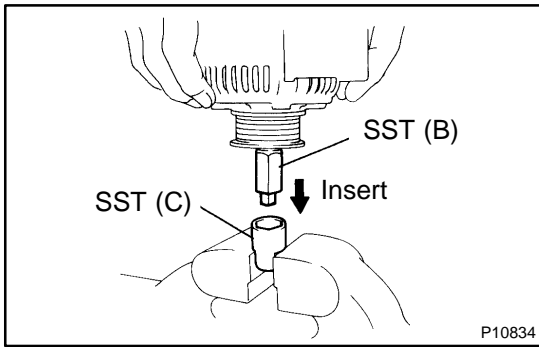

- (d) Mount SST (C) in a vise.
- (e) Insert SST (B) into SST (C), and attach the pulley nut to SST (C).

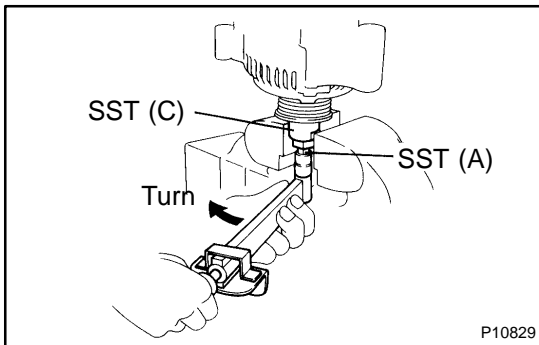

- (f) To torque the pulley nut, turn SST (A) in the direction shown in the illustration.
Torque: 110.5 N·m (1,125 kgf·cm, 81 ft·lbf)
- (g) Remove the generator from SST (C).

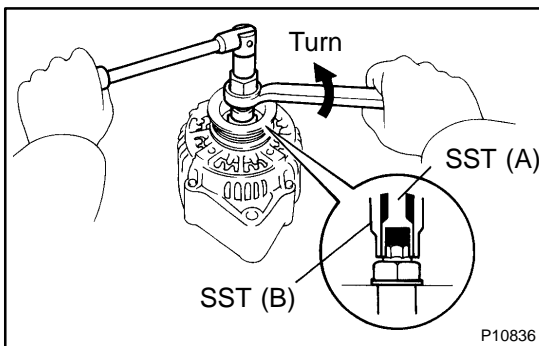

- (h) Turn SST (B), and remove SST (A and B).

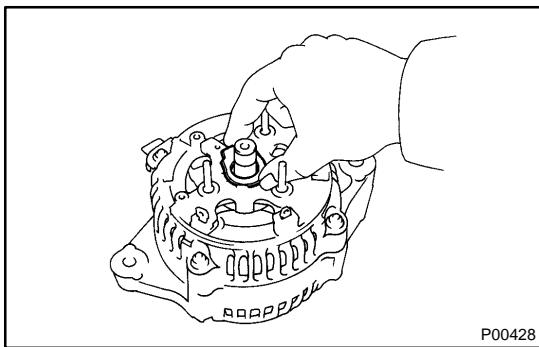

4. INSTALL RECTIFIER HOLDER

- (a) Place the seal plate on the rectifier end frame.

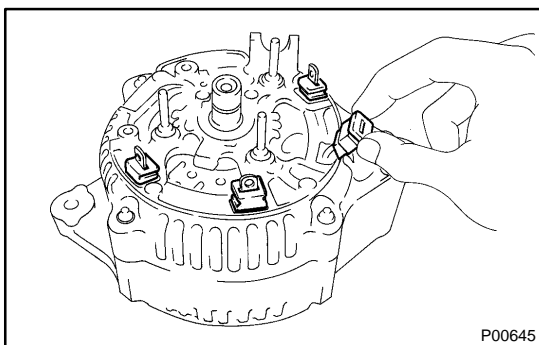

- (b) Install the 4 rubber insulators on the lead wires.

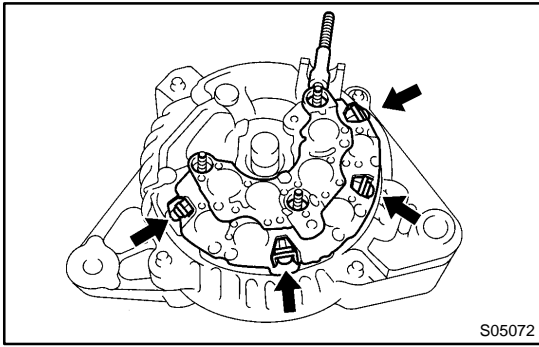

- (c) Install the rectifier holder with the 4 screws.
Torque: 2.9 N·m (30 kgf·cm, 26 in.-lbf)

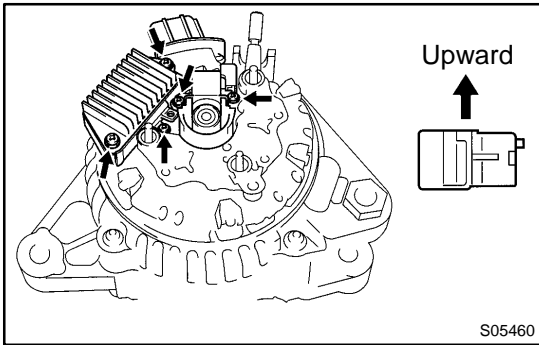

5. INSTALL VOLTAGE REGULATOR AND BRUSH HOLDER

- (a) Place the voltage regulator and brush holder on the rectifier end frame.

NOTICE:

Be careful of the holder installation direction.

- (b) Install the 5 screws.
Torque: 2.0 N·m (20 kgf·cm, 18 in.-lbf)

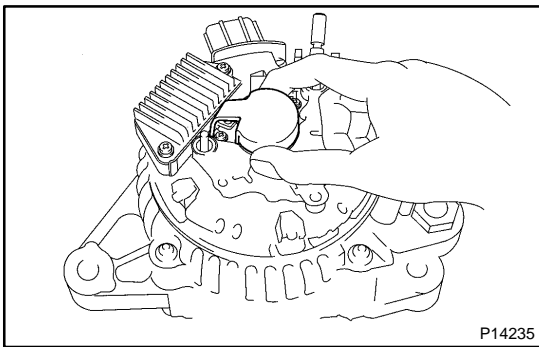

- (c) Place the brush holder cover on the brush holder.

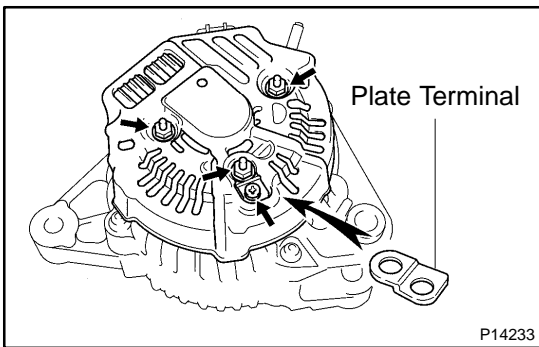

6. INSTALL REAR END COVER

- (a) Install the end cover and plate terminal with the 3 nuts and screw.

Torque:

Screw: 3.9 N·m (39 kgf·cm, 35 in.-lbf)

Nut: 4.4 N·m (45 kgf·cm, 39 in.-lbf)

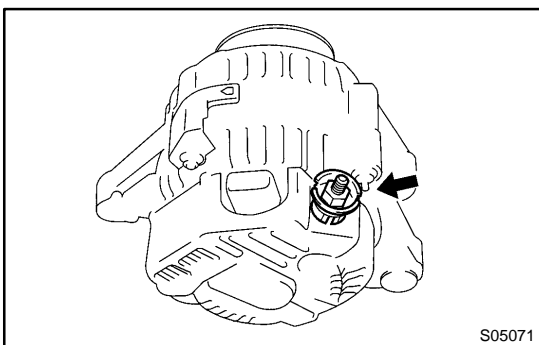

- (b) Install the terminal insulator with the nut.
Torque: 4.1 N·m (42 kgf·cm, 36 in.-lbf)

7. CHECK THAT ROTOR ROTATES SMOOTHLY

INSTALLATION

Installation is in the reverse order of removal (See page [CH-6](#)).