

COOLANT INSPECTION

CO02K-02

1. CHECK ENGINE COOLANT LEVEL AT RADIATOR RESERVOIR

The engine coolant level should be between the "LOW" and "FULL" lines, when the engine is cold. If low, check for leaks and add "Toyota Long Life Coolant" or Equivalent up to the "FULL" line.

2. CHECK ENGINE COOLANT QUALITY

(a) Remove the radiator cap from the water outlet.

CAUTION:

To avoid the danger of being burned, do not remove the radiator cap while the engine and radiator are still hot, as fluid and steam can be blown out under pressure.

(b) There should not be any excessive deposits of rust or scale around the radiator cap or water outlet filler hole, and the coolant should be free from oil.

If excessively dirty, clean the coolant passages and replace the coolant.

(c) Reinstall the radiator cap.

REPLACEMENT

1. DRAIN ENGINE COOLANT

- (a) Remove the radiator cap from the water outlet.

CAUTION:

To avoid the danger of being burned, do not remove the radiator cap while the engine and radiator are still hot, as fluid and steam can be blown out under pressure.

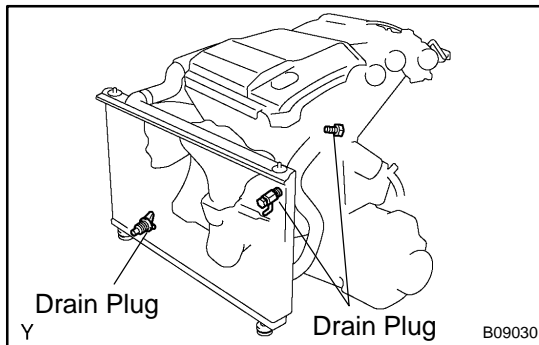

- (b) Loosen the radiator drain plug and engine drain plugs, and drain the coolant.

- (c) Close the drain plugs.

Torque:

RH engine drain plug on cylinder block side cover:

7 N·m (70 kgf·cm, 61 in.-lbf)

LH engine drain plug on union:

13 N·m (130 kgf·cm, 9 ft-lbf)

2. FILL ENGINE COOLANT

- (a) Slowly fill the system with coolant.

- ◆ Use of improper coolants may damage engine cooling system.
- ◆ Use "Toyota Long life Coolant" or equivalent and mix it with plain water according to the manufacturer's directions.
- ◆ Using of coolant which includes more than 50 % (freezing protection down to -35°C (-31°F) or 60 % (freezing protection down to -50°C (-58°F)) of ethylene-glycol is recommended but not more than 70 %.

NOTICE:

- ◆ Do not use an alcohol type coolant or plain water alone.
- ◆ The coolant should be mixed with plain water (preferably demineralized water or distilled water).
Capacity: 9.2 liters (9.7 US qts, 8.1 Imp. qts)

- (b) Install the radiator cap.

- (c) Start the engine, and bleed the cooling system.

- (d) If necessary, refill coolant into the reservoir up to the "FULL" line.

3. CHECK ENGINE COOLANT FOR LEAKS

4. CHECK ENGINE COOLANT SPECIFIC GRAVITY CORRECTLY

WATER PUMP COMPONENTS

CO02M-02

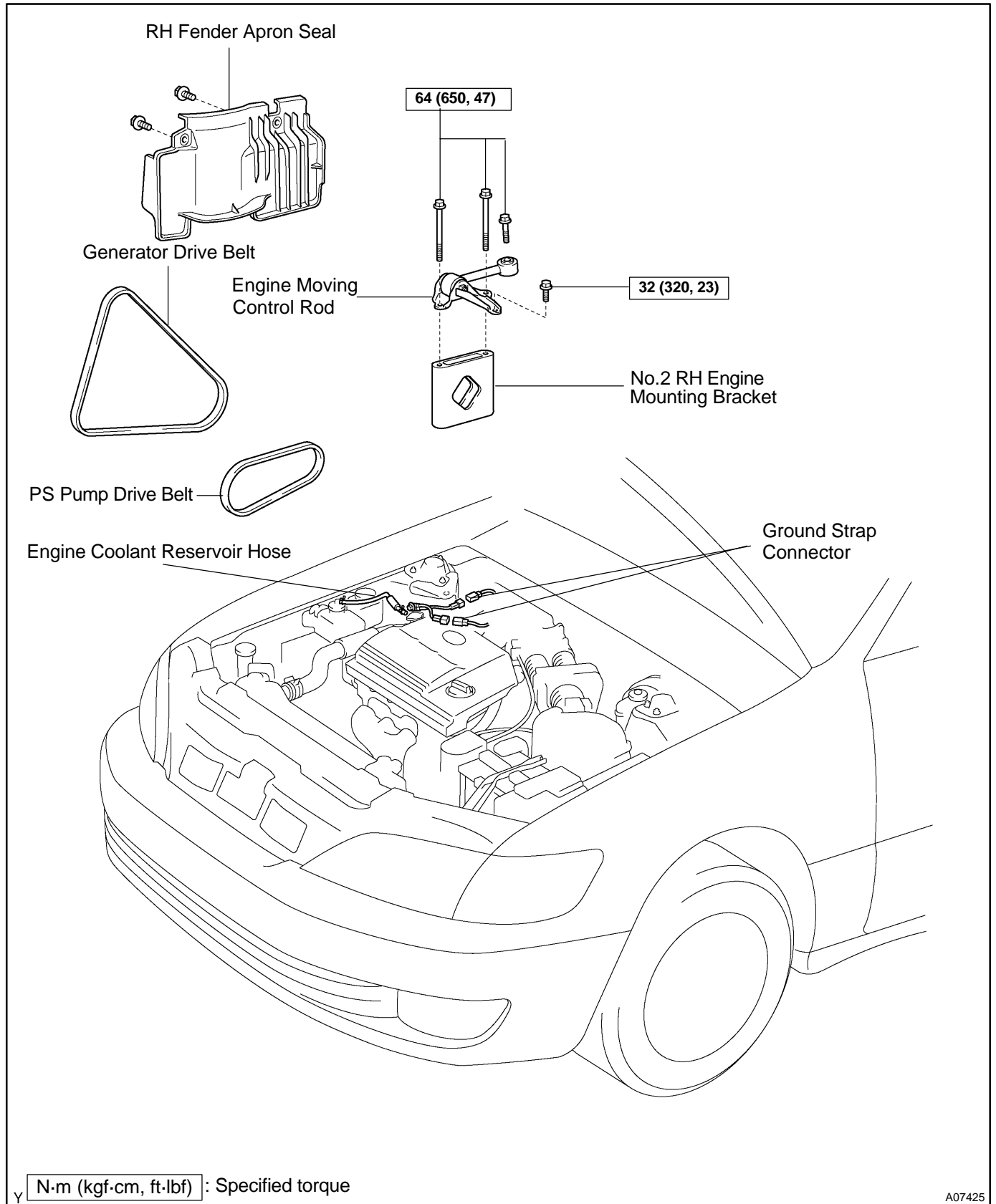

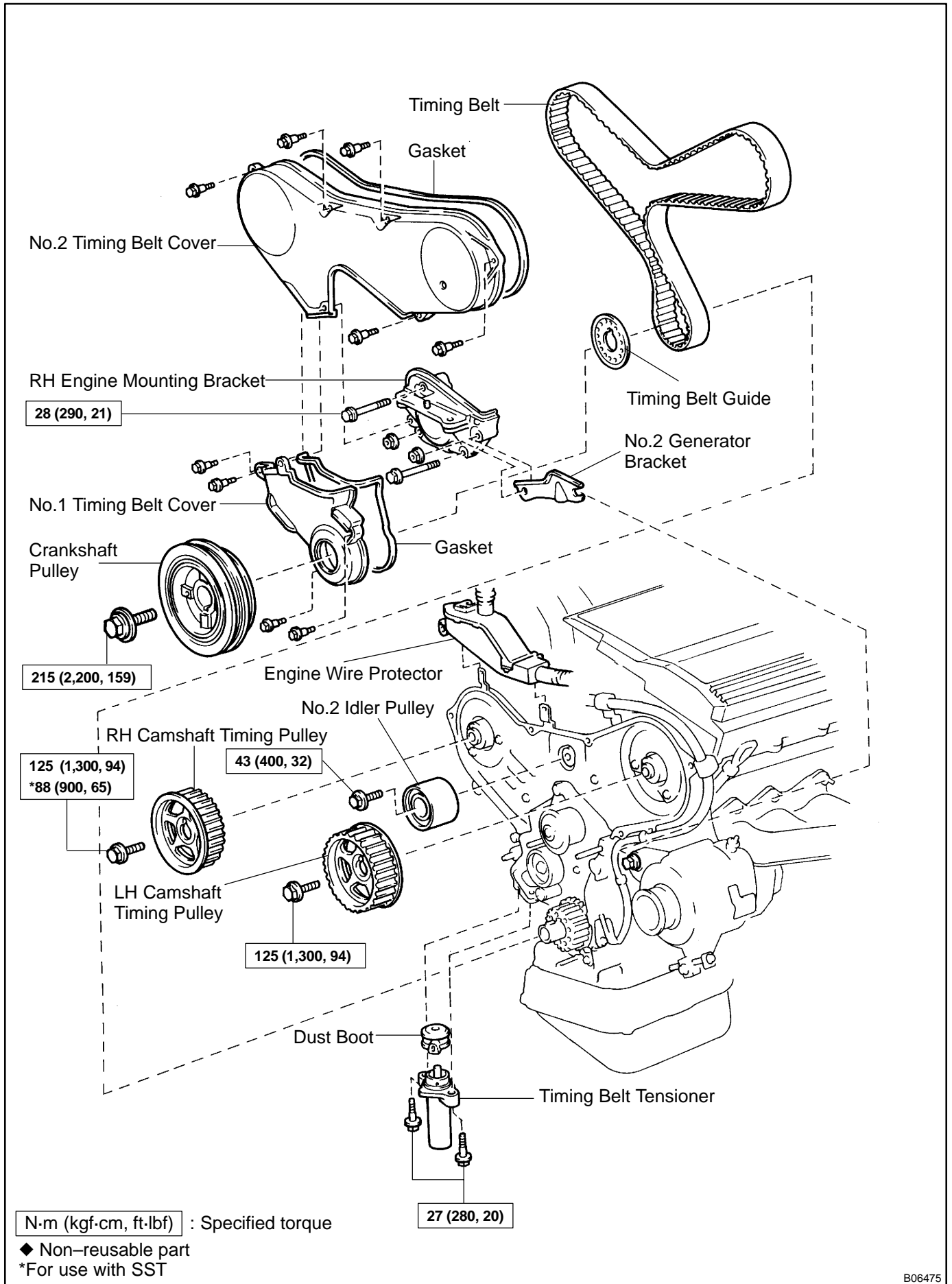

B06475

COOLING - WATER PUMP

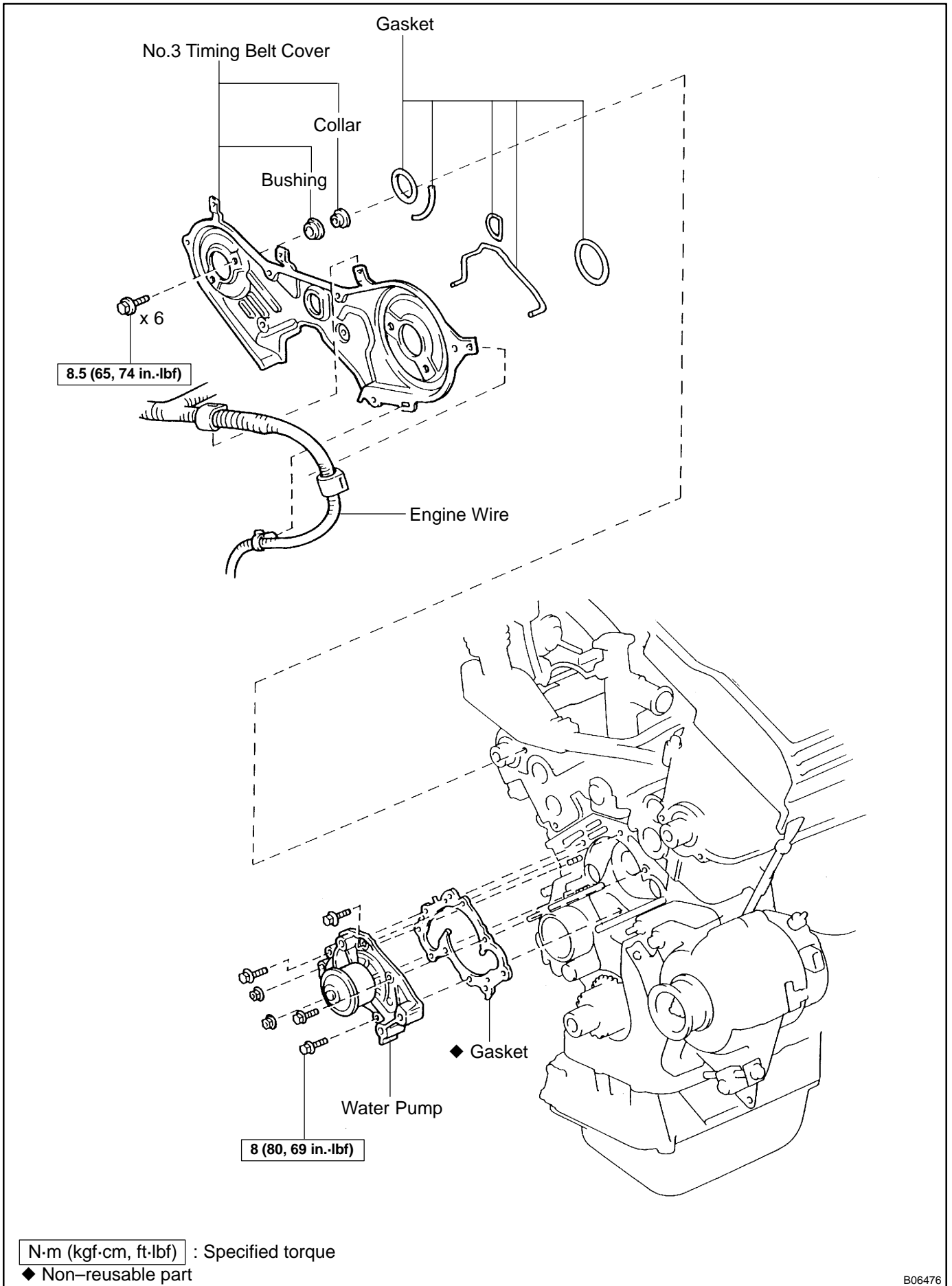

B06476

REMOVAL

1. DRAIN ENGINE COOLANT
2. REMOVE TIMING BELT (See page [EM-15](#))
3. REMOVE CAMSHAFT TIMING PULLEYS
(See page [EM-15](#))
4. REMOVE NO.2 IDLER PULLEY
(See page [EM-31](#))
5. REMOVE NO.3 TIMING BELT COVER
(See page [EM-15](#))

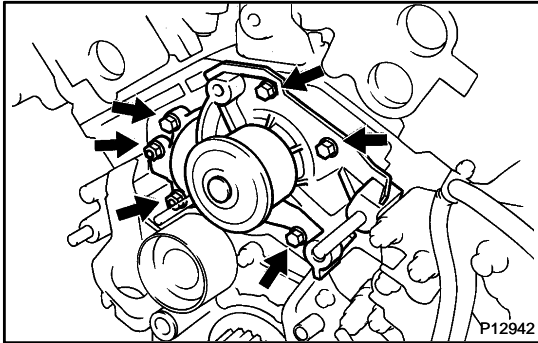

6. REMOVE WATER PUMP

Remove the 4 bolts, 2 nuts, water pump and gasket.

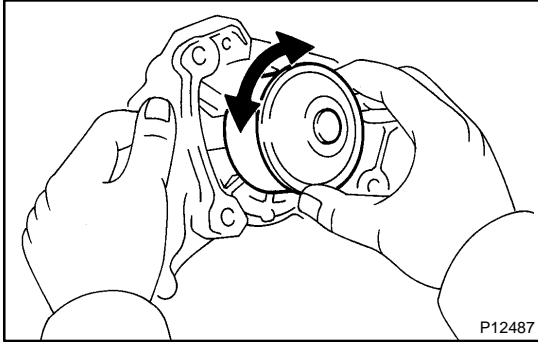

INSPECTION

1. INSPECT WATER PUMP

(a) Visually check the drain hole for coolant leakage.

If leakage is found, replace the water pump.

(b) Turn the pulley, and check that the water pump bearing moves smoothly and quietly.

If necessary, replace the water pump.

2. INSPECT TIMING BELT COMPONENTS

(See page [EM-19](#))

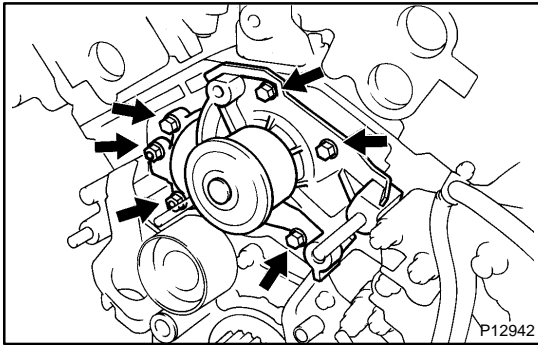

INSTALLATION

1. INSTALL WATER PUMP

Install a new gasket and the water pump with the 4 bolts and 2 nuts.

Torque: 8 N·m (80 kgf·cm, 69 in.-lbf)

NOTICE:

Do not get oil on the gasket.

2. INSTALL NO.3 TIMING BELT COVER

(See page [EM-59](#))

3. INSTALL NO.2 IDLER PULLEY

(See page [EM-21](#))

4. INSTALL CAMSHAFT TIMING PULLEYS

(See page [EM-21](#))

5. INSTALL TIMING BELT

(See page [EM-21](#))

6. FILL WITH ENGINE COOLANT

7. START ENGINE AND CHECK FOR LEAKS

8. RECHECK ENGINE COOLANT LEVEL

THERMOSTAT COMPONENTS

CO020-02

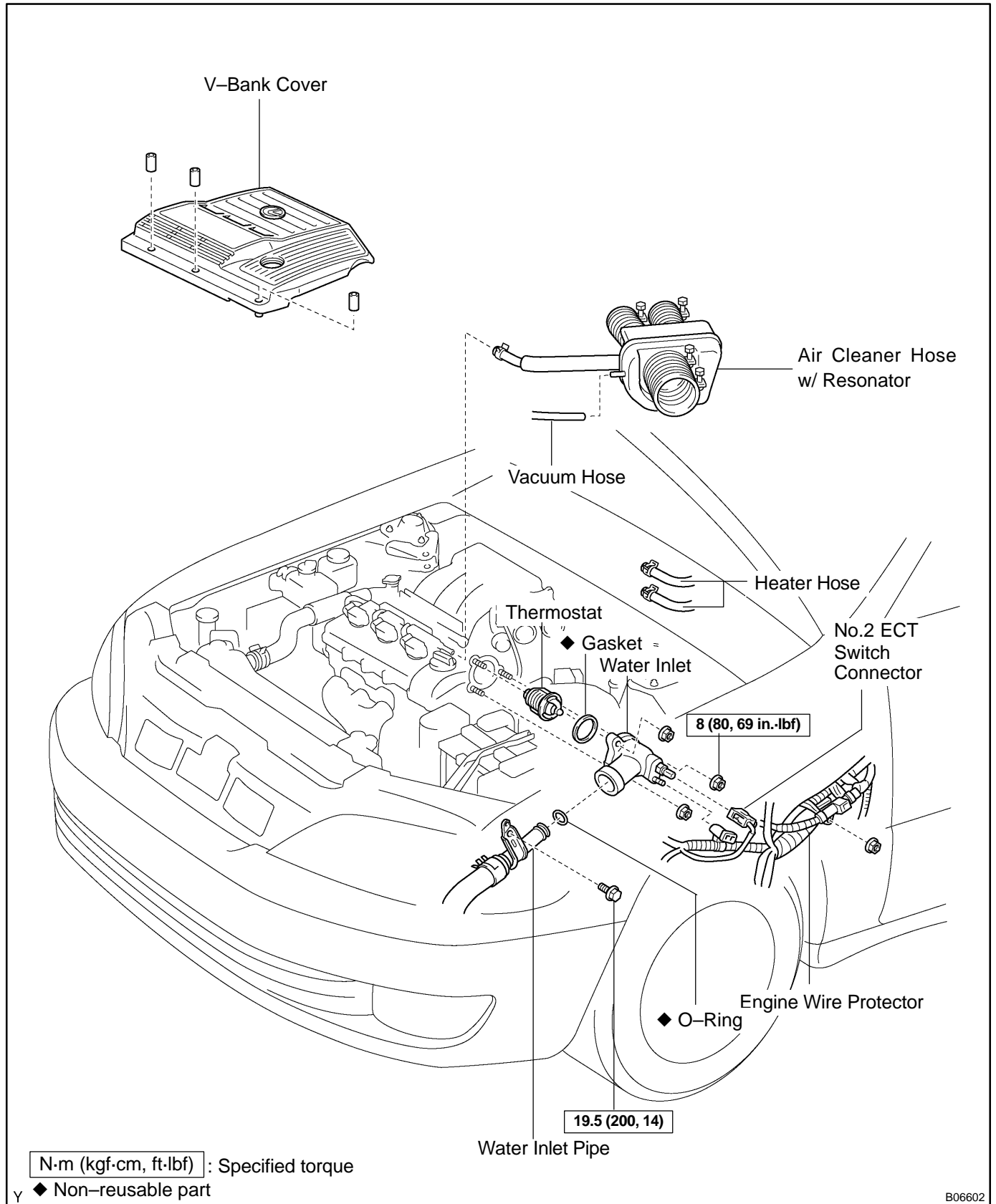

B06602

REMOVAL

HINT:

Removal of the thermostat would have an adverse effect, causing a lowering of cooling efficiency. Do not remove the thermostat, even if the engine tends to overheat.

1. DRAIN ENGINE COOLANT

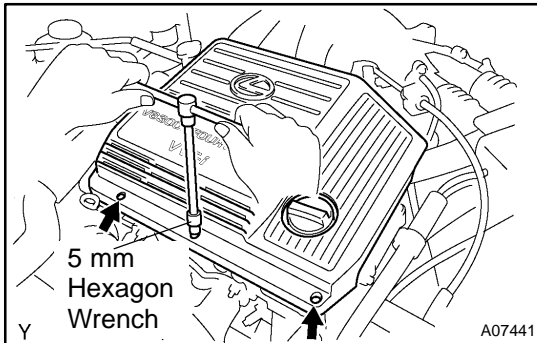

2. REMOVE V-BANK COVER

- Using a 5 mm hexagon wrench, remove the 3 cap nuts.
- Loosen the V-bank cover fastener counterclockwise.
- Remove the V-bank cover.

3. WARM UP ENGINE

Allow the engine to warm up to normal operating temperature.

4. REMOVE AIR CLEANER HOSE WITH RESONATOR

5. DISCONNECT HEATER HOSES

6. DISCONNECT NO.2 ECT SWITCH CONNECTOR

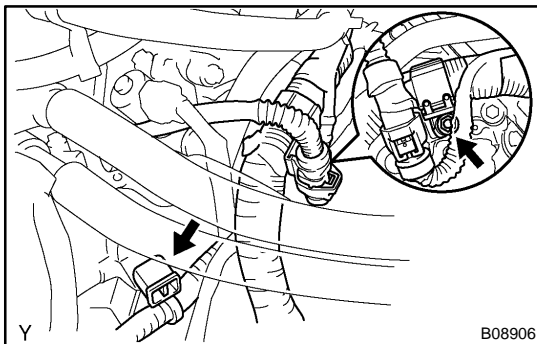

7. DISCONNECT ENGINE WIRE PROTECTOR FROM WATER INLET AND RH CYLINDER HEAD

Remove the nut and disconnect the clamp, and disconnect the engine wire protector from the water inlet and cylinder head.

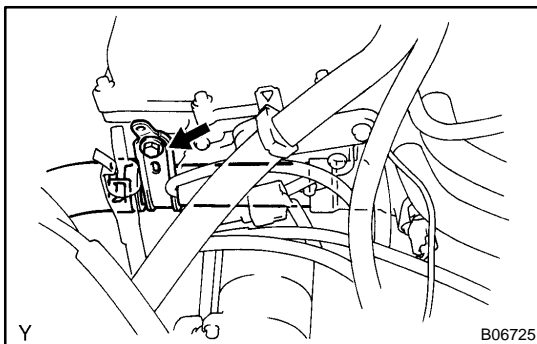

8. DISCONNECT WATER INLET PIPE FROM WATER INLET AND LH CYLINDER HEAD

- Remove the bolt, and disconnect the inlet pipe from the water inlet.
- Remove the O-ring from the inlet pipe.

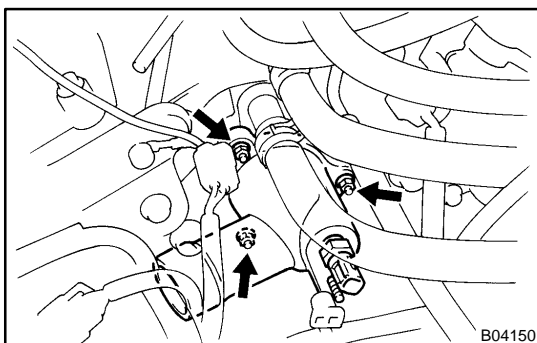

9. REMOVE WATER INLET AND THERMOSTAT

- Remove the 3 nuts, water inlet and thermostat.
- Remove the gasket from the thermostat.

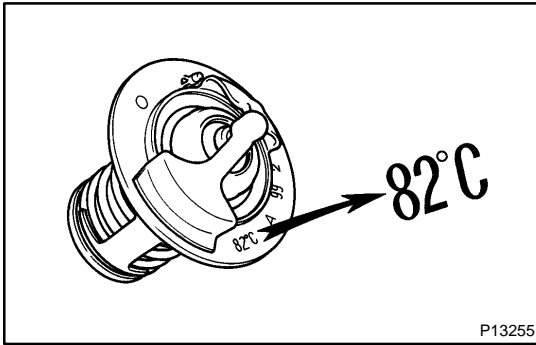

INSPECTION

INSPECT THERMOSTAT

HINT:

The thermostat is numbered with the valve opening temperature.

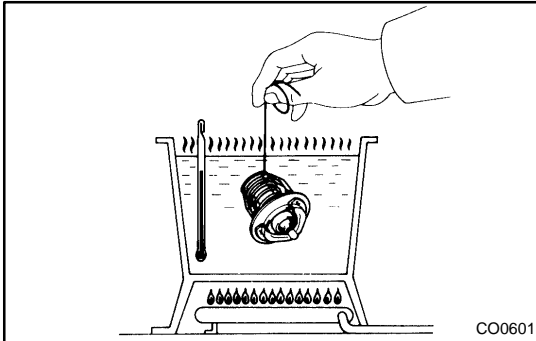

(a) Immerse the thermostat in water and gradually heat the water.

(b) Check the valve opening temperature.

Valve opening temperature:

80 – 84 °C (176 – 183 °F)

If the valve opening temperature is not as specified, replace the thermostat.

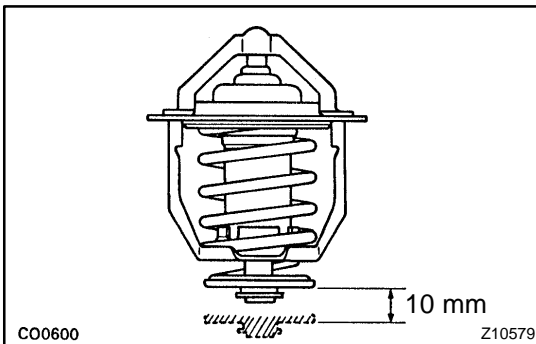

(c) Check the valve lift.

Valve lift: 10.0 mm (0.394 in.) or more at 95 °C (203 °F)

If the valve lift is not as specified, replace the thermostat.

(d) Check that the valve is fully closed when the thermostat is at low temperatures (below 40 °C (104 °F)).

If not closed, replace the thermostat.

INSTALLATION

1. PLACE THERMOSTAT IN WATER PUMP

- (a) Install a new gasket on to the thermostat.

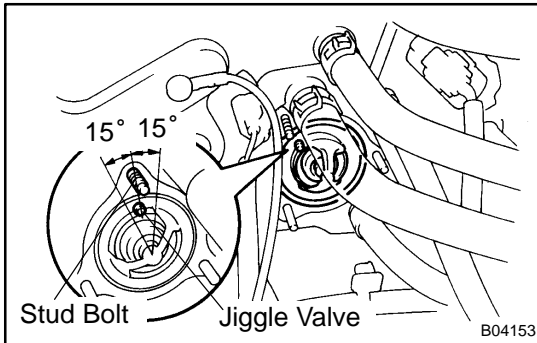

- (b) Align the thermostat jiggle valve with the upper stud bolt, and insert the thermostat in the water inlet housing.

HINT:

The jiggle valve may be set within 15° of either side of the prescribed position.

2. INSTALL WATER INLET

Install the water inlet with the 3 nuts.

Torque: 8 N·m (80 kgf·cm, 69 in.-lbf)

3. INSTALL WATER INLET PIPE

- (a) Install a new O-ring to the water inlet pipe.
- (b) Apply soapy water to the O-ring.
- (c) Connect the water inlet pipe to the water inlet.
- (d) Install the bolt holding the water inlet pipe to the LH cylinder head.

Torque: 19.5 N·m (200 kgf·cm, 14 ft·lbf)

4. INSTALL ENGINE WIRE PROTECTOR

5. CONNECT NO.2 ECT SWITCH CONNECTOR

6. CONNECT HEATER HOSES

7. REINSTALL AIR CLEANER HOSE WITH RESONATOR

8. INSTALL V-BANK COVER

- (a) Using 5 mm hexagon wrench, install the V-bank cover with the 3 cap nuts.
- (b) Press down the V-bank cover fastener.

9. FILL WITH ENGINE COOLANT

10. START ENGINE AND CHECK FOR LEAKS

11. RECHECK ENGINE COOLANT LEVEL

RADIATOR ON-VEHICLE CLEANING

CO02U-01

Using water or a steam cleaner, remove any mud or dirt from the radiator core.

NOTICE:

If using a high pressure type cleaner, be careful not to deform the fins of the radiator core. (i.e. Maintain a distance between the cleaner nozzle radiator core)

ON-VEHICLE INSPECTION

1. REMOVE RADIATOR CAP

CAUTION:

To avoid the danger of being burned, do not remove the radiator cap while the engine and radiator are still hot, as fluid and steam can be blow out under pressure.

2. INSPECT RADIATOR CAP

NOTICE:

- ◆ If the radiator cap has contaminations, always rinse it with water.
- ◆ When performing steps (a) and (b) below, keep the radiator cap tester at an angle of over 30° above the horizontal.
- ◆ Before using a radiator cap tester, wet the relief valve and pressure valve with engine coolant or water.

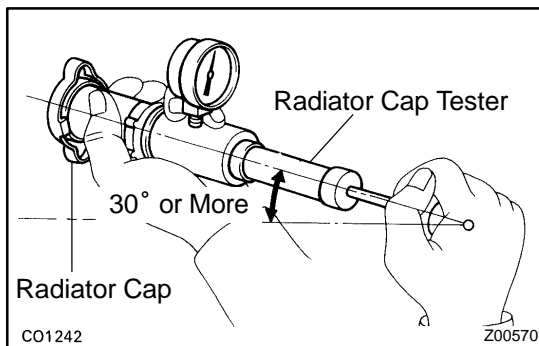

- (a) Using a radiator cap tester, slowly pump the tester and check that air is coming from the vacuum valve.

Pump speed: 1 push/(3 seconds or more)

NOTICE:

Push the pump at a constant speed.

If air is not coming from the vacuum valve, replace the radiator cap.

- (b) Pump the tester and measure the relief valve opening pressure.

Pump speed: 1 push within 1 second

NOTICE:

This pump speed is for the first pump only (in order to close the vacuum valve). After this, the pump speed can be reduced.

Standard opening pressure:

83 – 113 kPa (0.85 – 1.15 kgf/cm², 12.1 – 16.4 psi)

Minimum opening pressure:

69 kPa (0.7 kgf/cm², 10.0 psi)

HINT:

Use the tester's maximum reading as the opening pressure. If the opening pressure is less than minimum, replace the radiator cap.

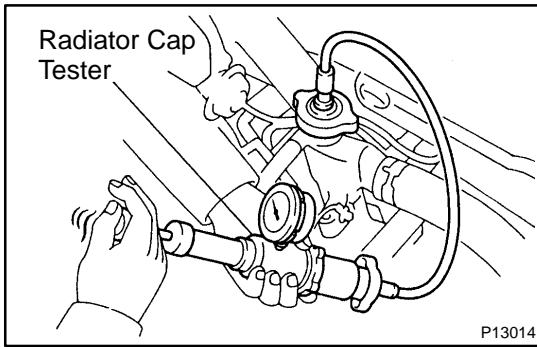
**3. INSPECT COOLING SYSTEM FOR LEAKS**

- (a) Fill the radiator with coolant and attach a radiator cap tester.
- (b) Warm up the engine.
- (c) Pump it to 127 kPa (1.3 kgf/cm², 18.5 psi), and check that the pressure does not drop.

If the pressure drops, check the hoses, radiator or water pump for leaks. If no external leaks are found, check the heater core, cylinder block and cylinder head.

4. REINSTALL RADIATOR CAP

COMPONENTS

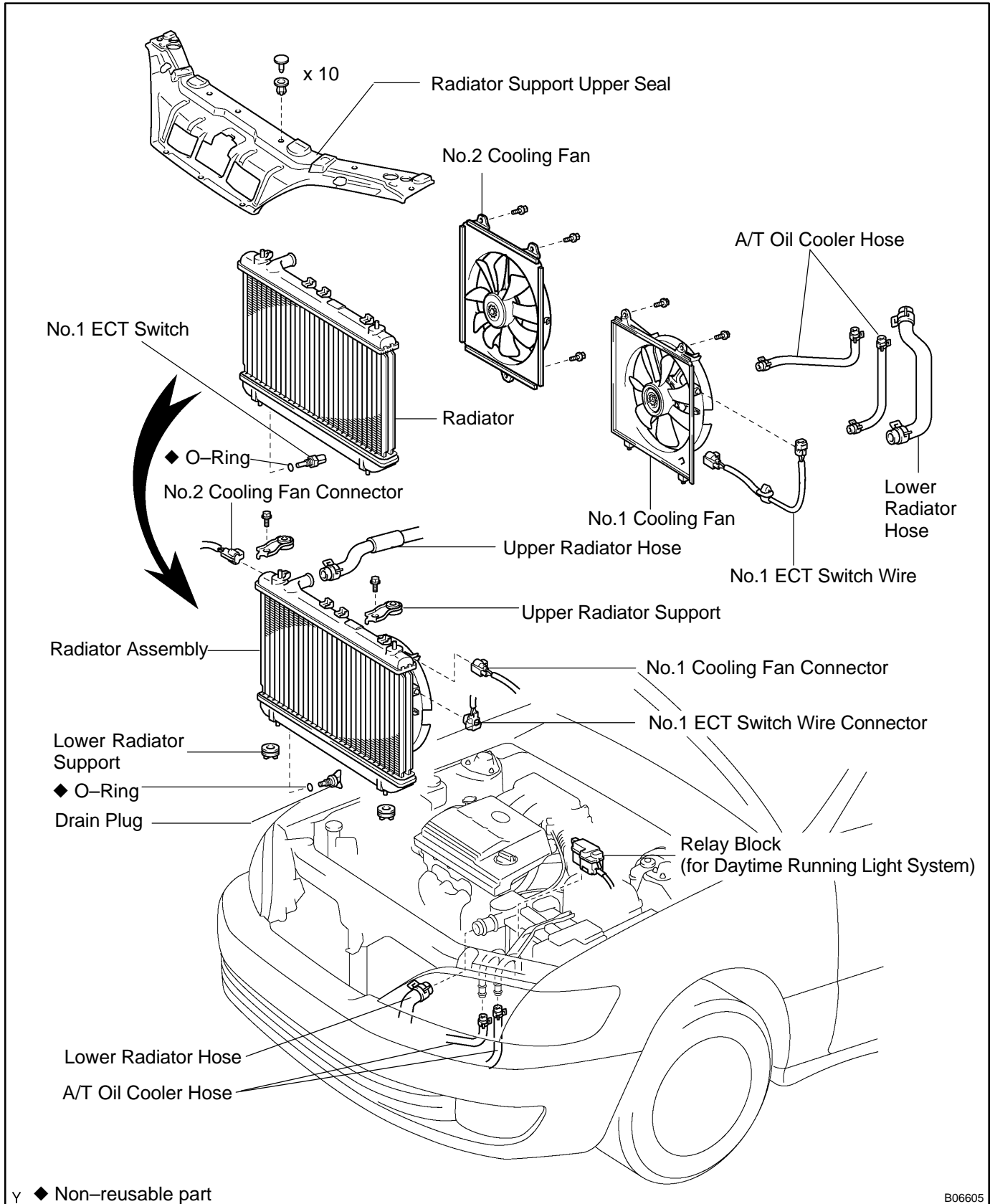

COOLING - RADIATOR

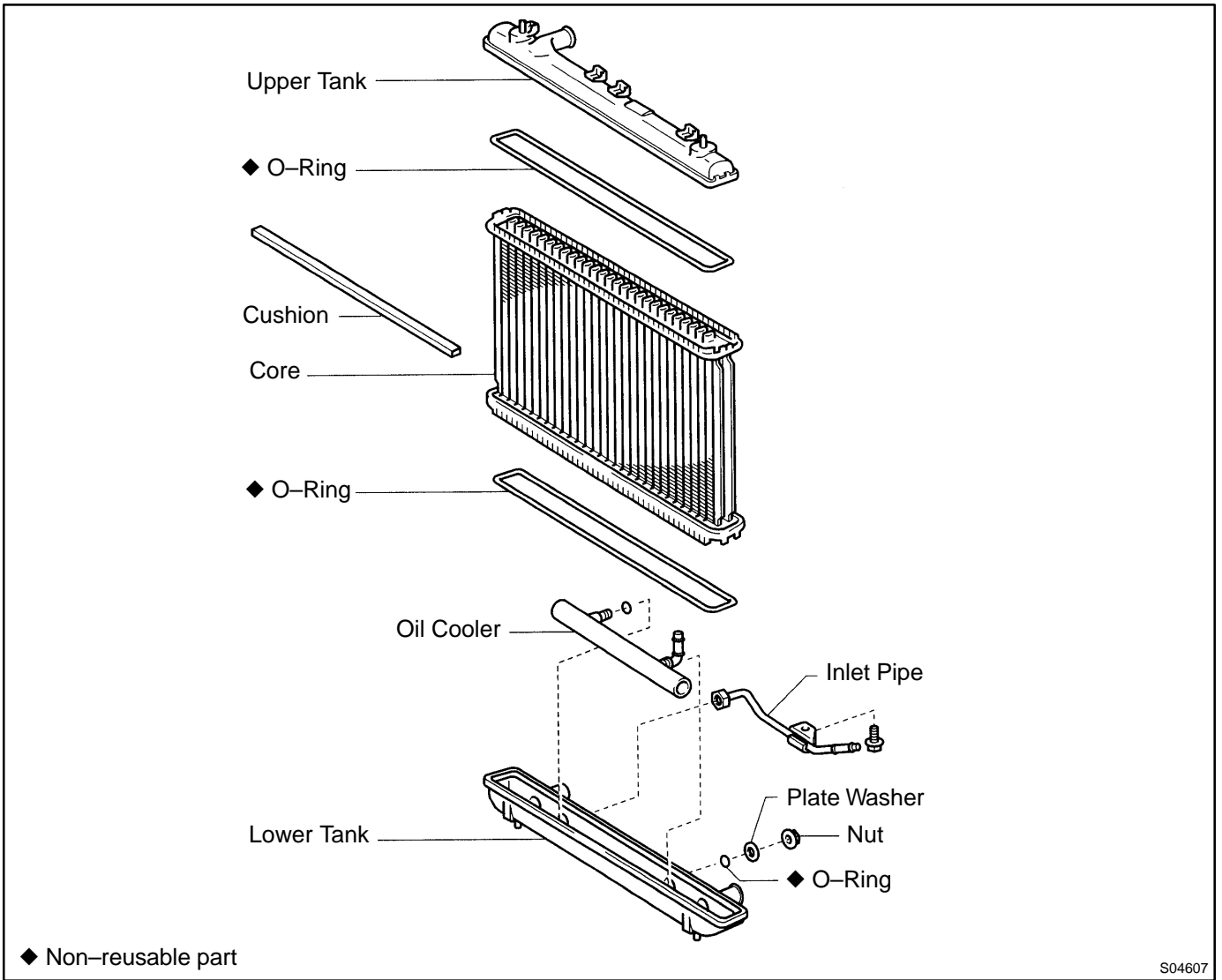

REMOVAL

HINT:

At the time of installation, please refer to the following items.

- ◆ Start the engine, and check for coolant and A/T fluid leaks.
 - ◆ Check the A/T fluid level (See page [DI-163](#)).
1. **DRAIN ENGINE COOLANT**
 2. **REMOVE RADIATOR SUPPORT UPPER SEAL**
 3. **DISCONNECT RELAY BLOCK (FOR DAYTIME RUNNING LIGHT SYSTEM) FROM BATTERY HOLD-DOWN CLAMP**
 4. **DISCONNECT UPPER RADIATOR HOSE FROM RADIATOR**
 5. **DISCONNECT LOWER RADIATOR HOSE FROM WATER INLET PIPE**
 6. **DISCONNECT A/T OIL COOLER HOSES FROM OIL COOLER PIPES**
 7. **DISCONNECT NO.1 AND NO.2 COOLING FAN CONNECTORS**
 8. **DISCONNECT NO.1 ECT SWITCH WIRE CONNECTOR**

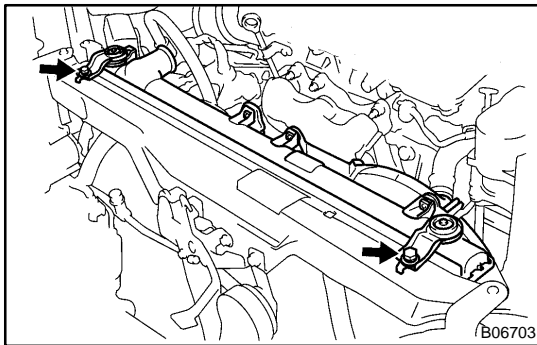

9. REMOVE RADIATOR AND COOLING FANS ASSEMBLY

- (a) Remove the 2 bolts and 2 upper supports.
Torque: 12.8 N·m (130 kgf·cm, 9 ft·lbf)
- (b) Lift out the radiator, and remove the radiator and cooling fans assembly.
- (c) Remove the 2 lower supports.

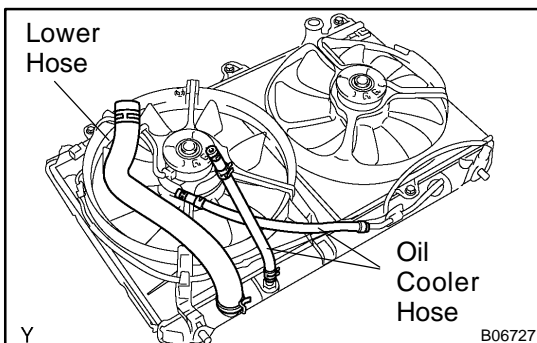

10. **REMOVE A/T OIL COOLER HOSES FROM RADIATOR**
11. **REMOVE LOWER RADIATOR HOSE FROM RADIATOR**

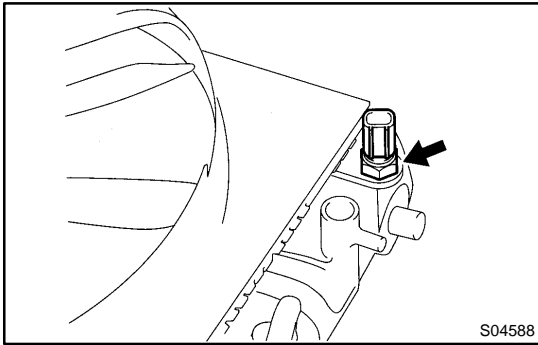

12. REMOVE NO.1 ECT SWITCH

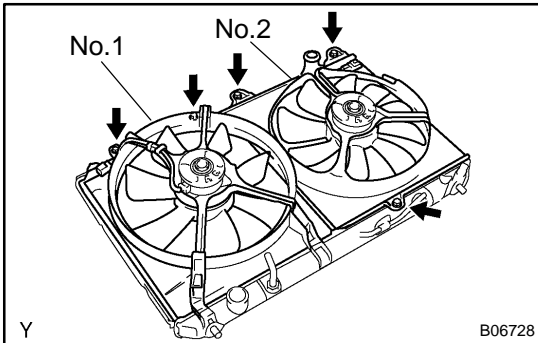

13. REMOVE NO.1 COOLING FAN FROM RADIATOR

Remove the 2 bolts and cooling fan.

Torque: 5.0 N·m (50 kgf·cm, 44 in.-lbf)

14. REMOVE NO.2 COOLING FAN FROM RADIATOR

Remove the 3 bolts and cooling fan.

Torque: 5.0 N·m (50 kgf·cm, 44 in.-lbf)

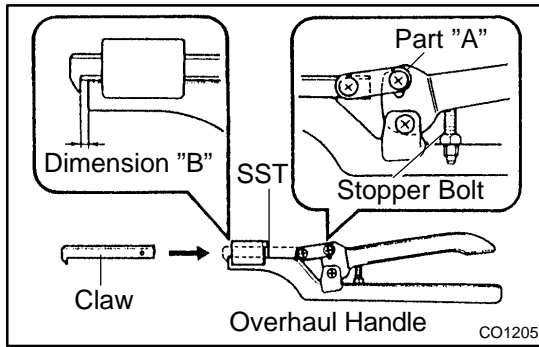

DISASSEMBLY

1. REMOVE CUSHION FROM RADIATOR

2. ASSEMBLE SST

SST 09230-01010

- (a) Install the claw to the overhaul handle, inserting it in the hole in part "A" as shown in the diagram.
- (b) While gripping the handle, adjust the stopper bolt so that dimension "B" shown in the diagram is 0.2 – 0.5 mm (0.008 – 0.020 in.).

NOTICE:

If this adjustment is not done, the claw may be damaged.

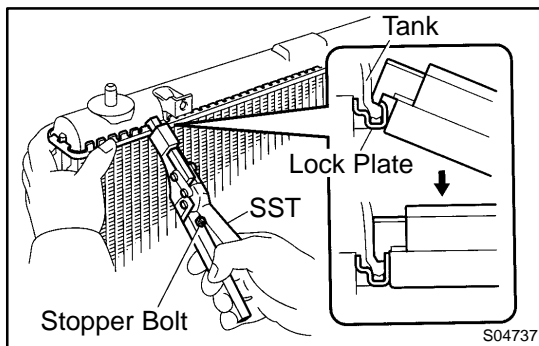

3. UNCAULK LOCK PLATES

Using SST to release the caulking, squeeze the handle until stopped by the stopper bolt.

SST 09230-01010

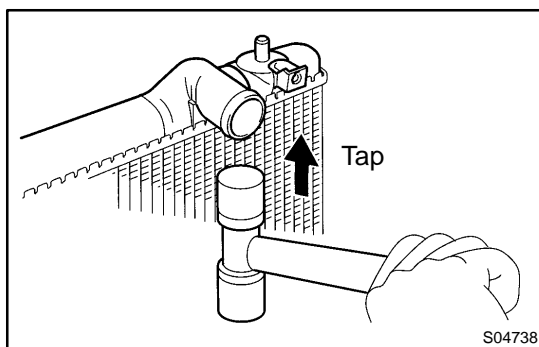

4. REMOVE TANKS AND O-RINGS

- (a) Lightly tap the bracket of the radiator (or radiator hose inlet or outlet) with a soft-faced hammer and remove the tank.
- (b) Remove the O-ring.

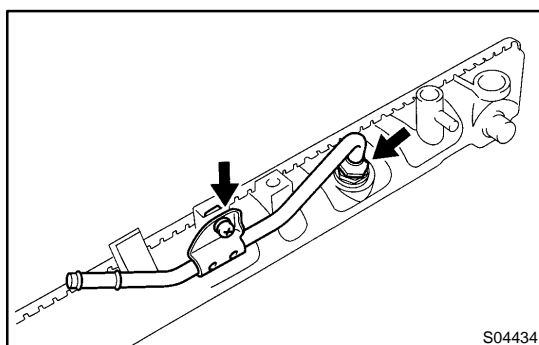

5. REMOVE OIL COOLER FROM LOWER TANK

- (a) Remove the pipe.
- (b) Remove the nuts and plate washers.
- (c) Remove the oil cooler and O-rings.

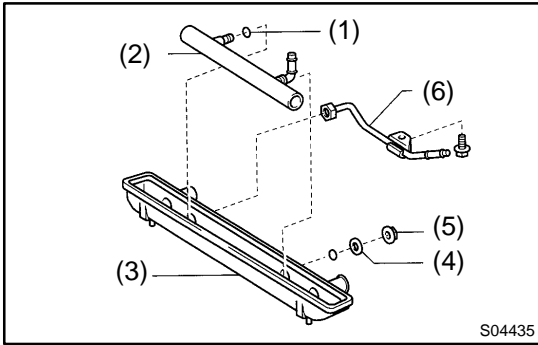

REASSEMBLY

1. INSTALL OIL COOLER TO LOWER TANK

- (a) Clean the O-ring contact surface of the lower tank and oil cooler.
- (b) Install a new O-rings (1) to the oil cooler (2).
- (c) Install the oil cooler with the O-rings to the lower tank (3).
- (d) Install the plate washers (4), and nuts (5). Torque the nuts.

Torque: 8.3 N·m (85 kgf·cm, 74 in.-lbf)

- (e) Install the pipe (6).

Torque: 14.7 N·m (150 kgf·cm, 11 ft·lbf)

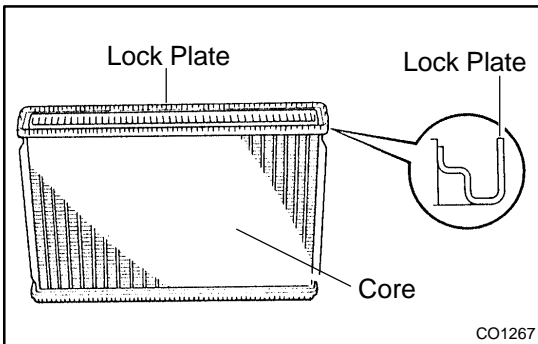

2. INSPECT LOCK PLATE

Inspect the lock plate for damage.

HINT:

- ◆ If the sides of the lock plate groove are deformed, reassembly of the tank will be impossible.
- ◆ Therefore, first correct any deformation with pliers or similar object. Water leakage will result if the bottom of the lock plate groove is damaged or dented, Therefore, repair or replace if necessary.

NOTICE:

The radiator can only be recalced 2 times. After the 2nd time, the radiator core must be replaced.

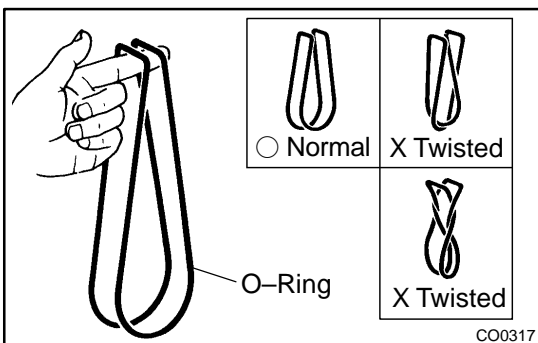

3. INSTALL NEW O-RINGS AND TANKS

- (a) After checking that there are no foreign objects in the lock plate groove, install the new O-ring without twisting it.

HINT:

When cleaning the lock plate groove, lightly rub it with sand paper without scratching it.

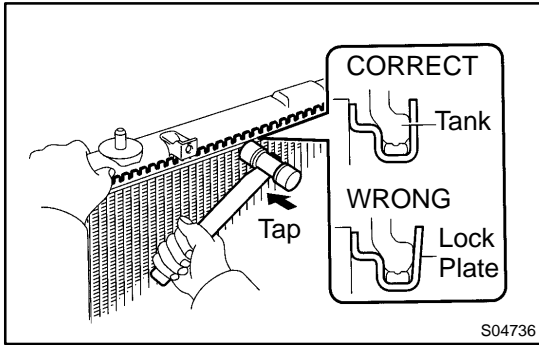

- (b) Install the tank without damaging the O-ring.
- (c) Tap the lock plate with a soft-faced hammer so that there is no gap between it and the tank.

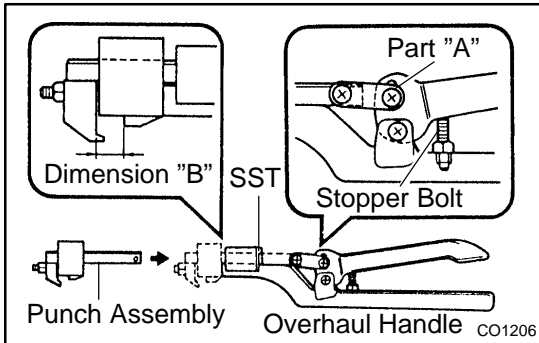

4. ASSEMBLE SST

SST 09230-01010, 09231-14010

- (a) Install the punch assembly to the overhaul handle, inserting it in the hole in part "A" as shown in the illustration.
- (b) While gripping the handle, adjust the stopper bolt so that dimension "B" shown in the diagram.

Dimension "B": 8.4 mm (0.34 in.)

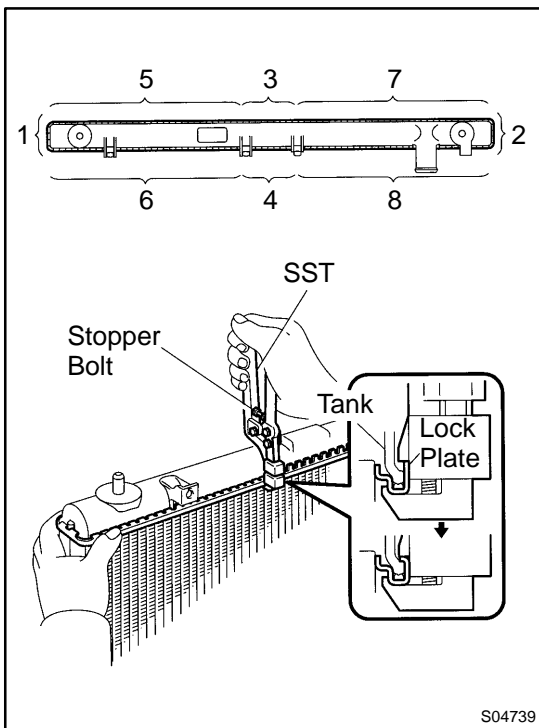

5. CAULK LOCK PLATE

- (a) Lightly press SST against the lock plate in the order shown in the illustration. After repeating this a few times, fully caulk the lock plate by squeezing the handle until stopped by the stopper plate.

SST 09230-01010

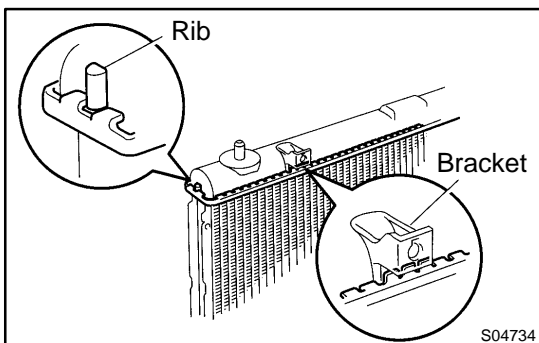

HINT:

- ◆ Do not stake the areas protruding around the pipes, brackets or tank ribs.

COOLING - RADIATOR

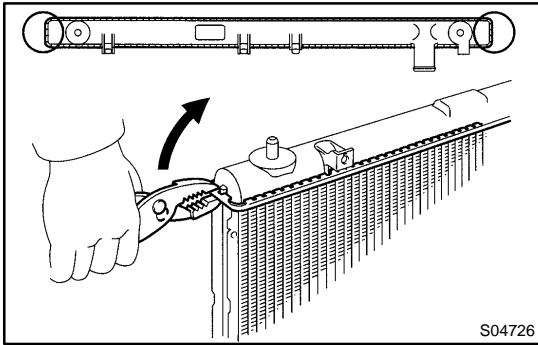

- ◆ The points shown in the rib sides and oil cooler near here cannot be staked with SST. Use pliers or similar object and be careful not to damage the core plates.

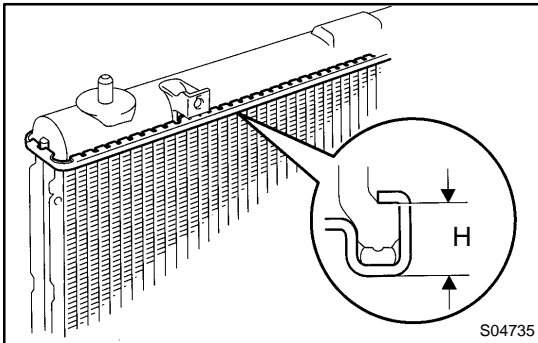

- (b) Check the lock plate height (H) after completing the caulking.

Plate height (H): 7.4 – 7.8 mm (0.2959 – 0.3119 in.)

If not within the specified height, adjust the stopper bolt of the handle again and caulk again.

6. INSTALL CUSHION

INSTALLATION

Installation is in the reverse order of removal (See page [CO-18](#)).

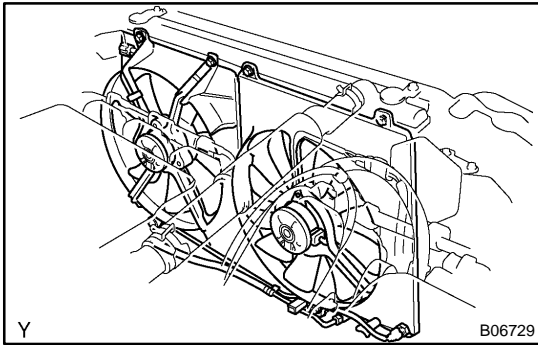

ELECTRIC COOLING FAN ON-VEHICLE INSPECTION

CO031-02

1. CHECK COOLING FAN OPERATION WITH LOW TEMPERATURE (Below 88°C (190°F))

- (a) Turn the ignition switch ON.
- (b) Check that the cooling fan stops.

If not, check the cooling fan relay and ECT switch, and check for a separated connector or severed wire between the cooling fan relay and ECT switch.

- (c) Disconnect the No.1 ECT switch connector.

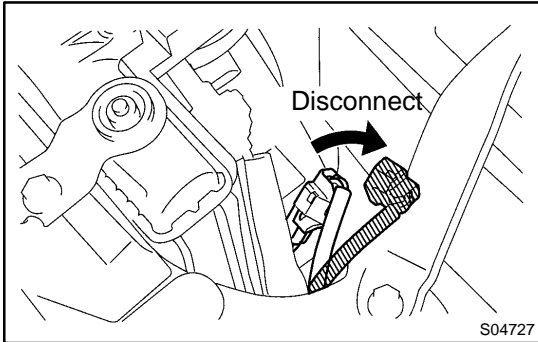

- (d) Check that the cooling fan rotates.

If not, check the fuses, engine main relay, cooling fan relay, cooling fan, and check for a short circuit between the cooling fan relay and ECT switch.

- (e) Reconnect the No.1 ECT switch connector.

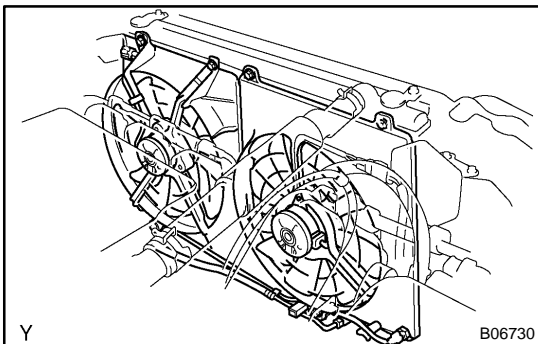

2. CHECK COOLING FAN OPERATION WITH HIGH TEMPERATURE (Above 98°C (208°F))

- (a) Start the engine, and raise coolant temperature to above 98°C (208°F).

- (b) Check that the cooling fan rotates.

If not, replace the No.1 ECT switch.

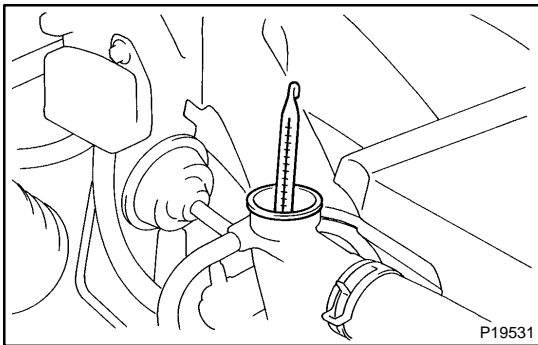

3. INSPECT NO.1 COOLING FAN

- (a) Disconnect the cooling fan connector.

- (b) Connect battery and ammeter to the cooling fan connector.

- (c) Check that the cooling fan rotates smoothly, and check the reading on the ammeter.

Standard amperage: 8.5 – 11.5 A at 20°C (68°F)

- (d) Reconnect the cooling fan connector.

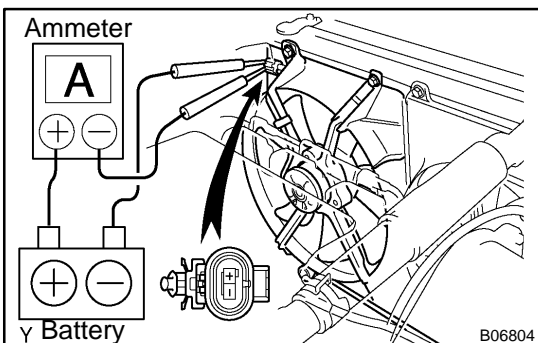

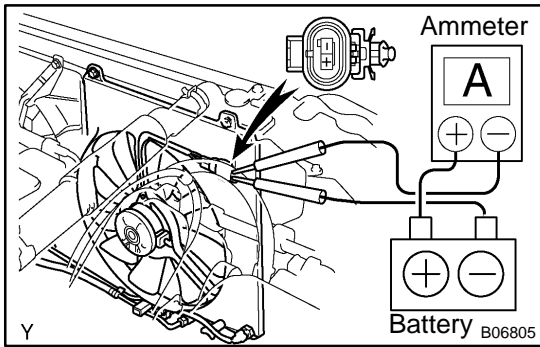
**4. INSPECT NO.2 COOLING FAN**

- (a) Disconnect the cooling fan connector.
- (b) Connect battery and ammeter to the cooling fan connector.
- (c) Check that the cooling fan rotates smoothly, and check the reading on the ammeter.
Standard amperage: 8.5 – 11.5 A at 20°C (68°F)
- (d) Reconnect the cooling fan connector.

COMPONENTS

No.1

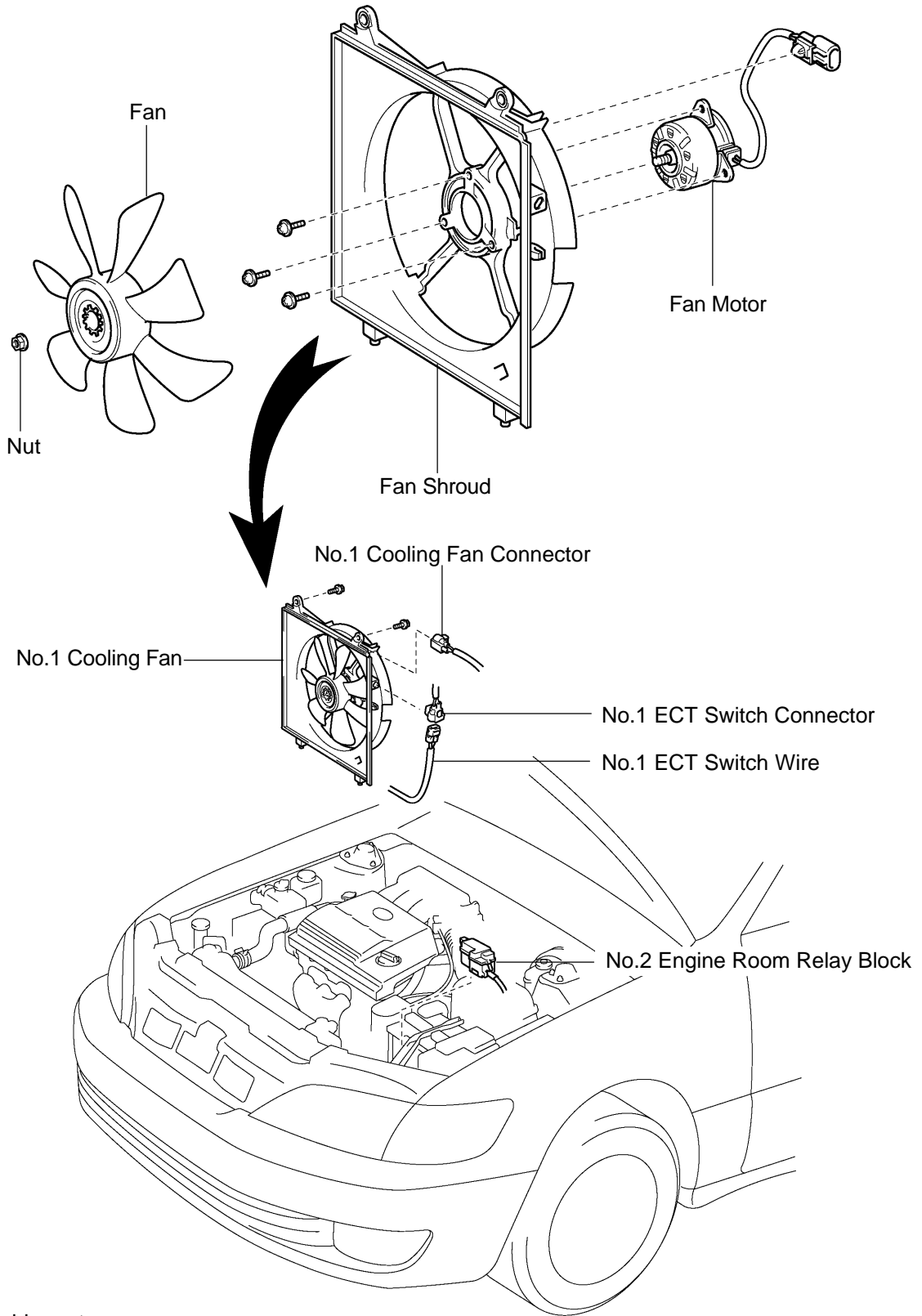

Y ◆ Non-reusable part

B08643

No.2

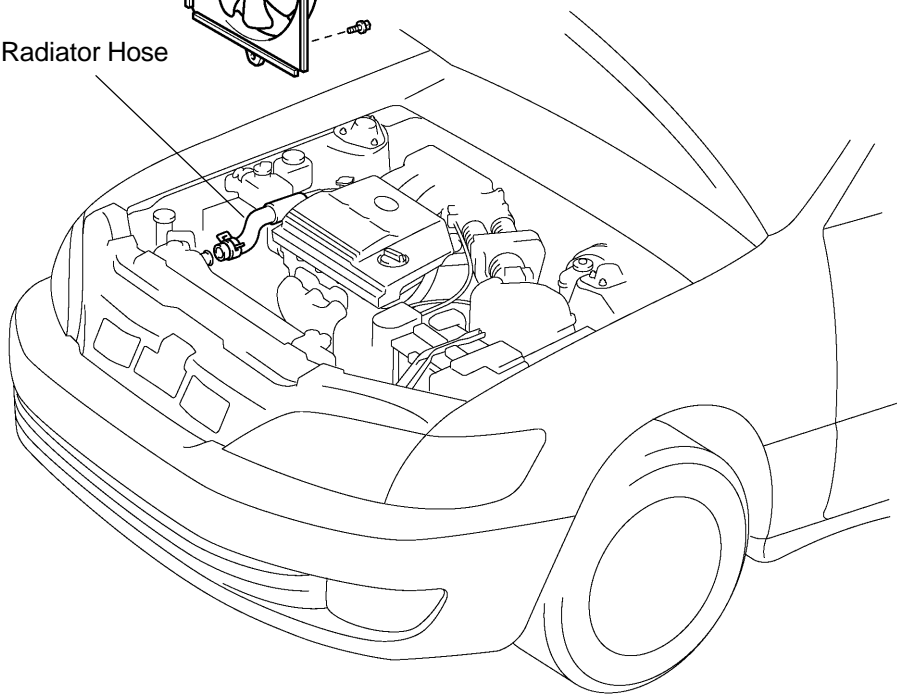
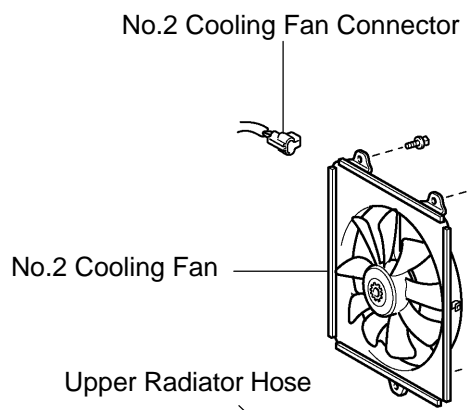
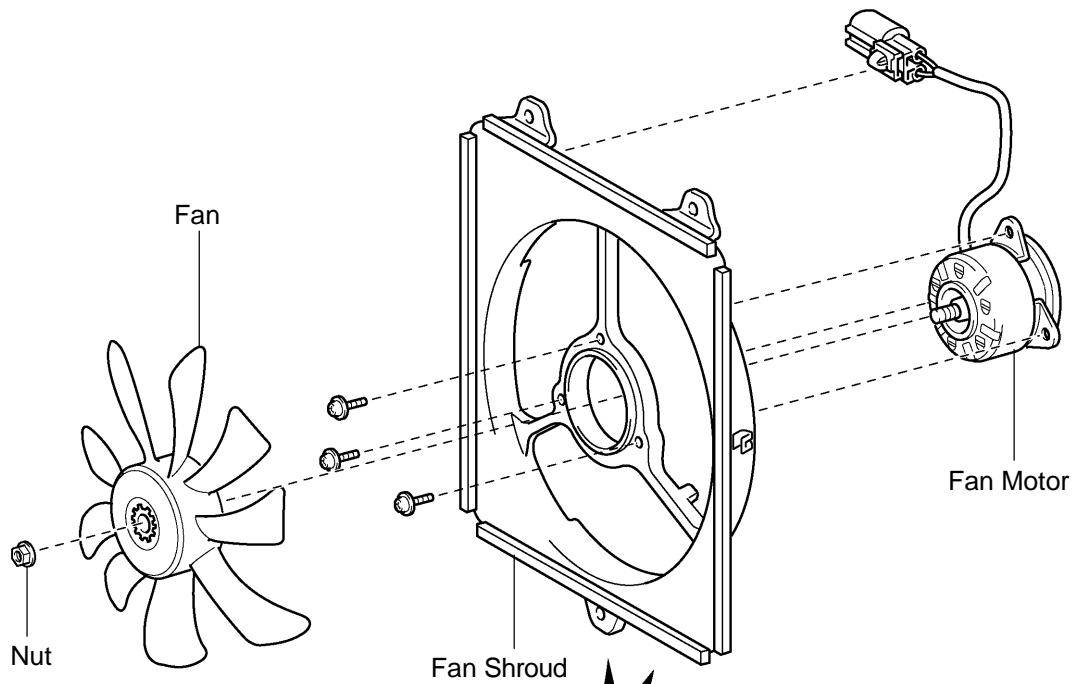

◆ Non-reusable part

B08644

REMOVAL

1. REMOVE NO.1 COOLING FAN

- (a) Disconnect the No.2 engine room relay block from the battery hold-down clamp.
- (b) Disconnect the cooling fan connector.
- (c) Disconnect the No.1 ECT switch wire connector.
- (d) Disconnect the No.1 ECT switch wire clamps.

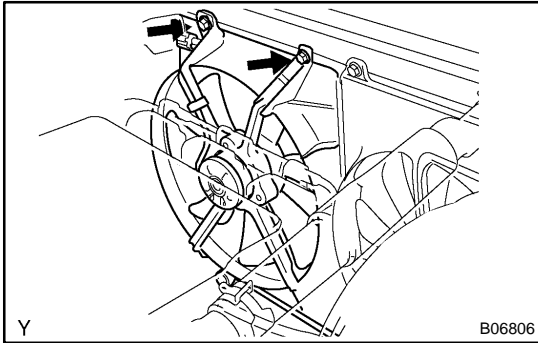

- (e) Remove the 2 bolts and cooling fan.
Torque: 5.0 N·m (50 kgf·cm, 44 in.-lbf)

2. REMOVE NO.2 COOLING FAN

- (a) Drain the engine coolant.
- (b) Disconnect the upper radiator hose from the radiator.
- (c) Disconnect the cooling fan connector.

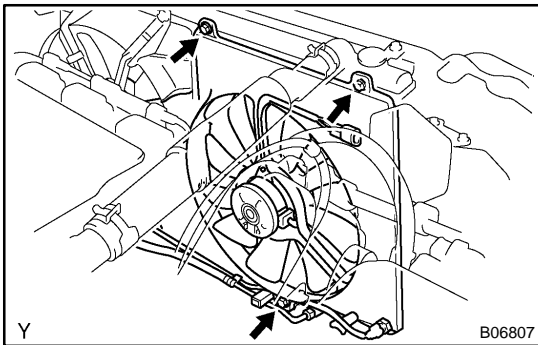

- (d) Remove the 3 bolts and cooling fan.
Torque: 5.0 N·m (50 kgf·cm, 44 in.-lbf)

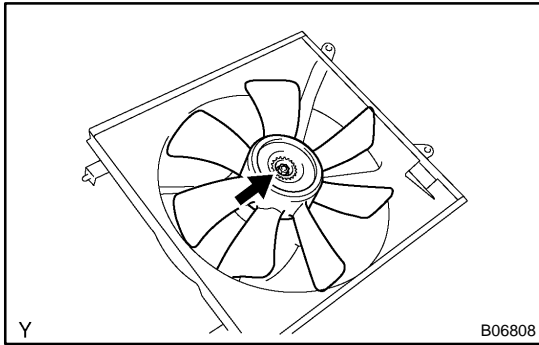

DISASSEMBLY

1. REMOVE NO.1 COOLING FAN

(a) Remove the nut and fan.

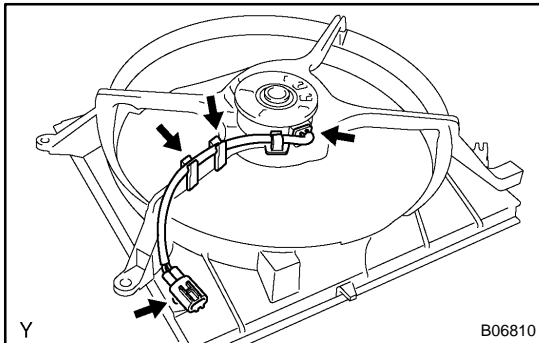

(b) Disconnect the lead wire from the fan shroud.

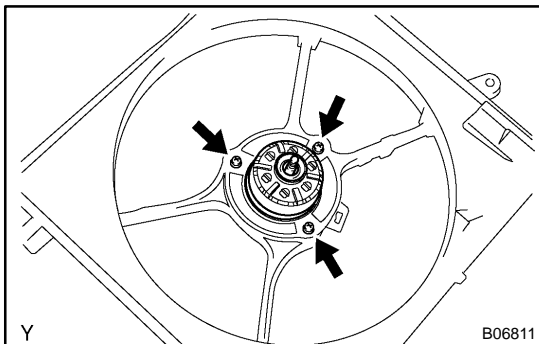

(c) Remove the 3 screws and fan motor.

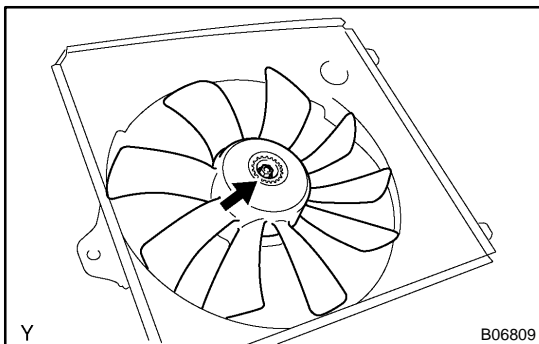

2. REMOVE NO.2 COOLING FAN

(a) Remove the nut and fan.

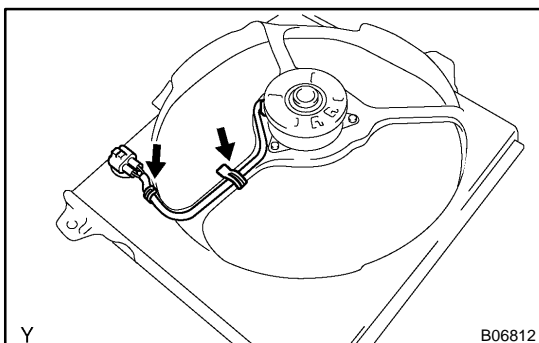

(b) Disconnect the lead wire from the fan shroud.

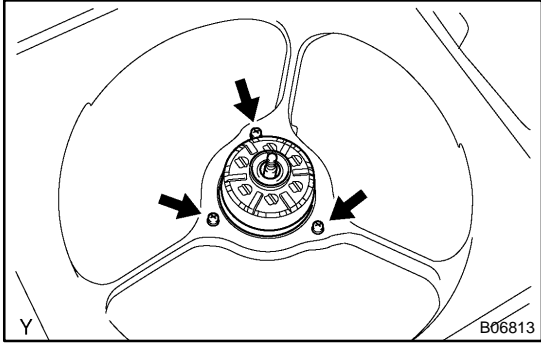

(c) Remove the 3 screws and fan motor.

REASSEMBLY

Reassembly is in the reverse order of disassembly (See page [CO-30](#)).

INSTALLATION

Installation is in the reverse order of removal (See page [CO-29](#)).

ENGINE COOLANT TEMPERATURE (ECT) SWITCH INSPECTION

CO037-02

1. DRAIN ENGINE COOLANT

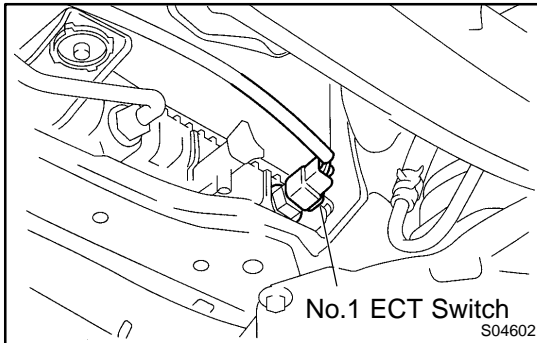

2. INSPECT NO.1 ECT SWITCH

- (a) Remove the No.1 ECT switch.

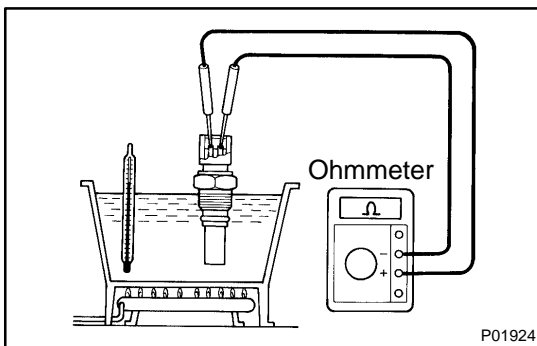

- (b) Inspect the No.1 ECT switch.

- (1) Using an ohmmeter, check that there is no continuity between the terminals when the coolant temperature is above 98°C (208°F).

If there is continuity, replace the switch.

- (2) Check that there is continuity, between the terminals when the coolant temperature is below 88°C (190°F).

If there is no continuity, replace the switch.

- (c) Reinstall the No.1 ECT switch.

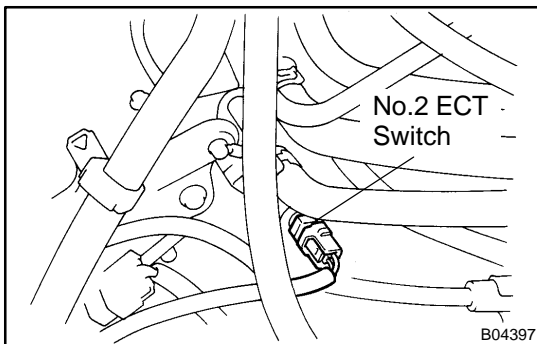

3. INSPECT NO.2 ECT SWITCH

- (a) Remove the No.2 ECT switch.

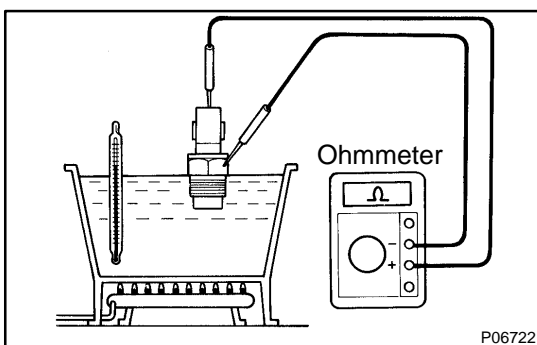

- (b) Inspect the No.2 ECT switch.

- (1) Using an ohmmeter, check that there is continuity between terminals when the coolant temperature is above 94°C (201°F).

If there is no continuity, replace the switch.

- (2) Check that there is no continuity between the terminals when the coolant temperature is below 83°C (181°F).

If there is continuity, replace the switch.

- (c) Reinstall the No.2 ECT switch.

4. REFILL ENGINE COOLANT
5. START ENGINE AND CHECK FOR COOLANT LEAKS

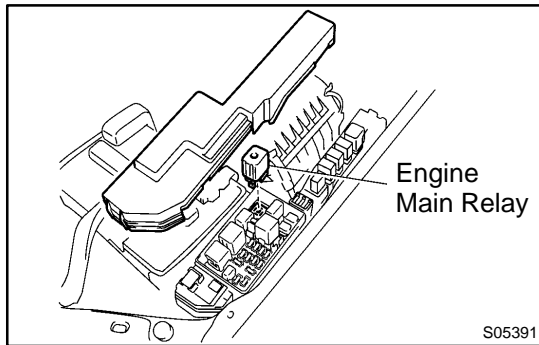

ENGINE MAIN RELAY INSPECTION

CO038-03

1. REMOVE RELAY BOX COVER
2. REMOVE ENGINE MAIN RELAY (Marking: ENGINE MAIN)

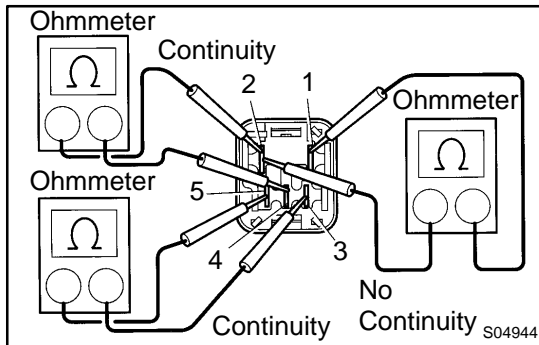

3. INSPECT RELAY CONTINUITY

- (a) Using an ohmmeter, check that there is continuity between terminals 3 and 5.

If there is no continuity, replace the relay.

- (b) Check that there is continuity between terminals 2 and 4. If there is no continuity, replace the relay.

- (c) Check that there is no continuity between terminals 1 and 2.

If there is continuity, replace the relay.

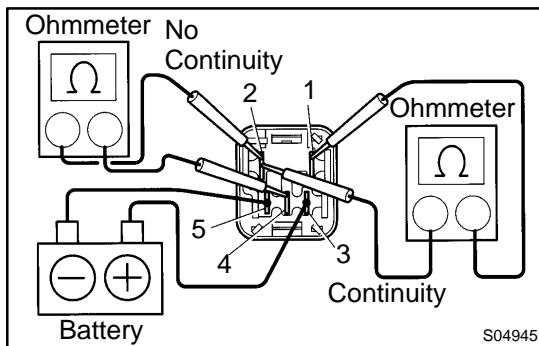

4. INSPECT RELAY OPERATION

- (a) Apply battery positive voltage across terminals 3 and 5.

- (b) Using an ohmmeter, check that there is no continuity between terminals 2 and 4.

If there is continuity, replace the relay.

- (c) Check that there is continuity between terminals 1 and 2. If there is no continuity, replace the relay.

5. REINSTALL ENGINE MAIN RELAY
6. REINSTALL RELAY BOX COVER

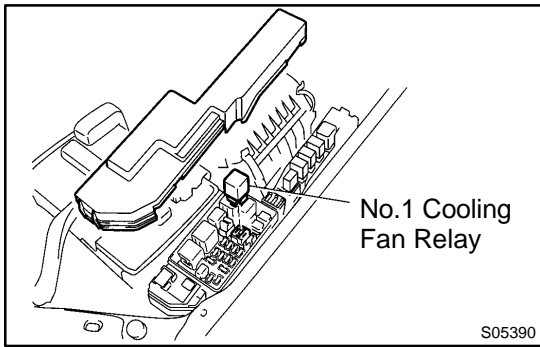

COOLING FAN RELAY INSPECTION

CO039-02

1. REMOVE RELAY BOX COVER
2. INSPECT NO.1 COOLING FAN RELAY
 - (a) Remove the No.1 cooling fan relay. (Marking: FAN NO.1)

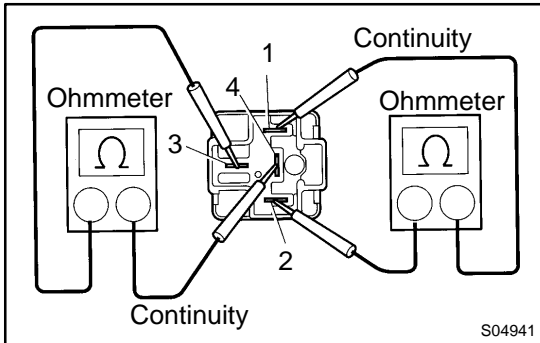

- (b) Inspect the No.1 cooling fan relay continuity. (DENSO)
 - (1) Using an ohmmeter, check that there is continuity between terminals 1 and 2.

If there is no continuity, replace the relay.

- (2) Check that there is continuity between terminals 3 and 4.

If there is no continuity, replace the relay.

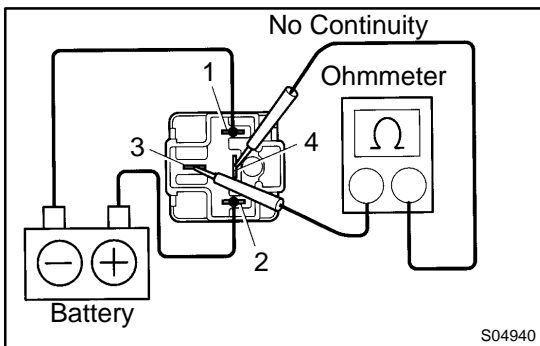

- (c) Inspect the No.1 cooling fan relay operation. (DENSO)
 - (1) Apply battery positive voltage across terminals 1 and 2.

- (2) Using an ohmmeter, check that there is no continuity between terminals 3 and 4.

If there is continuity, replace the relay.

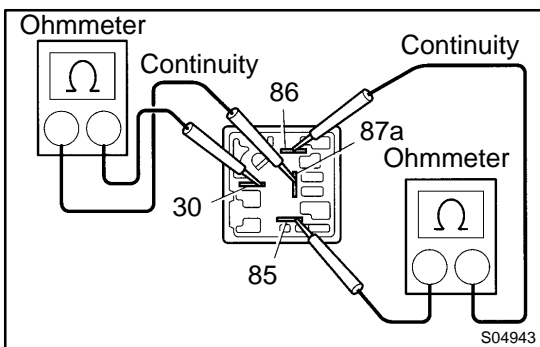

- (d) Inspect the No.1 cooling fan relay continuity. (BOSCH)
 - (1) Using an ohmmeter, check that there is continuity between terminals 85 and 86.

If there is no continuity, replace the relay.

- (2) Check that there is continuity between terminals 30 and 87a.

If there is no continuity, replace the relay.

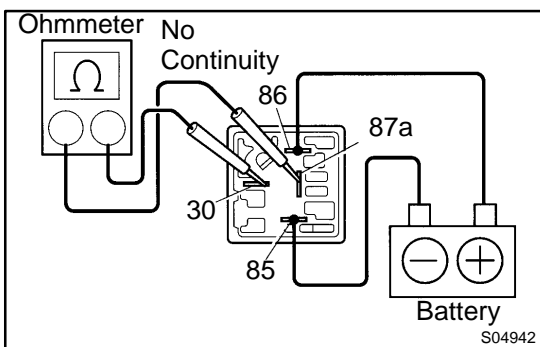

- (e) Inspect the No.1 cooling fan relay operation. (BOSCH)
 - (1) Apply battery positive voltage across terminals 85 and 86.

- (2) Using an ohmmeter, check that there is no continuity between terminals 30 and 87a.

If there is continuity, replace the relay.

- (f) Install the No.1 cooling fan relay.

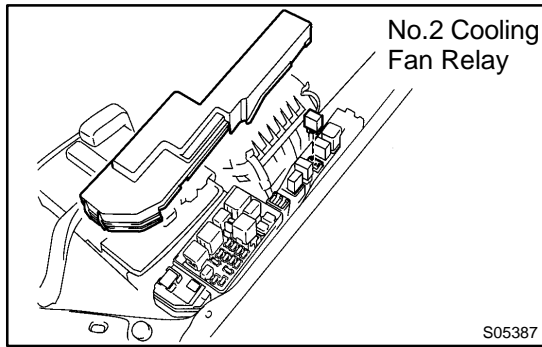

3. INSPECT NO.2 COOLING FAN RELAY

(a) Remove the No.2 cooling fan relay. (Marking: FAN NO.2)

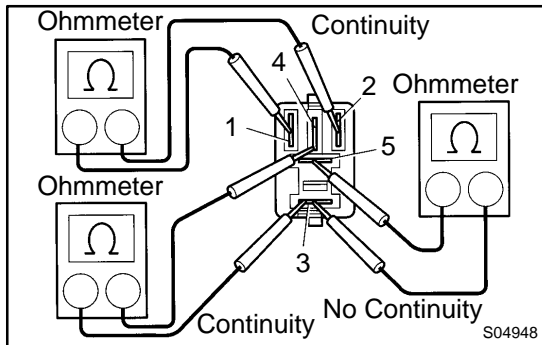

(b) Inspect the No.2 cooling fan relay continuity.

(1) Using an ohmmeter, check that there is continuity between terminals 1 and 2.

If there is no continuity, replace the relay.

(2) Check that there is continuity between terminals 3 and 4.

If there is no continuity, replace the relay.

(3) Check that there is no continuity between terminals 3 and 5.

If there is continuity, replace the relay.

(c) Inspect the No.2 cooling fan relay operation.

(1) Apply battery positive voltage across terminals 1 and 2.

(2) Using an ohmmeter, check that there is no continuity between terminals 3 and 4.

If there is continuity, replace the relay.

(3) Using an ohmmeter, check that there is continuity between terminals 3 and 5.

If there is no continuity, replace the relay.

(d) Install the No.2 cooling fan relay.

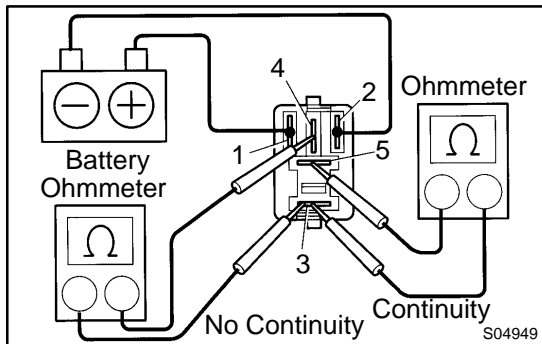

4. INSPECT NO.3 COOLING FAN RELAY

(a) Remove the No.3 cooling fan relay. (Marking: FAN NO.3)

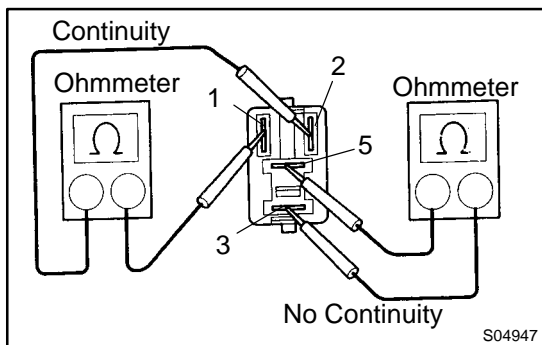
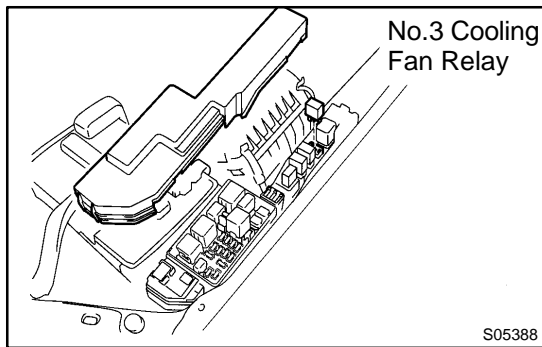

(b) Inspect the No.3 cooling fan relay continuity.

(1) Using an ohmmeter, check that there is continuity between terminals 1 and 2.

If there is no continuity, replace the relay.

(2) Check that there is no continuity between terminals 3 and 5.

If there is continuity, replace the relay.

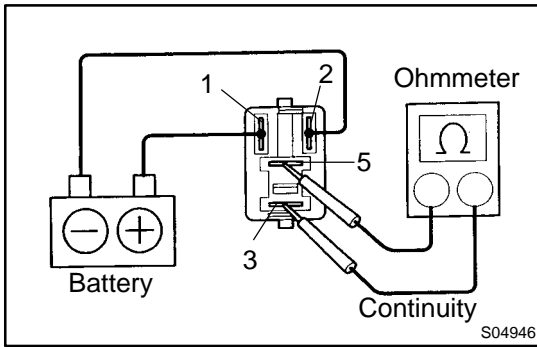

- (c) Inspect the No.3 cooling fan relay operation.
- (1) Apply battery positive voltage across terminals 1 and 2.
 - (2) Using an ohmmeter, check that there is continuity between terminals 3 and 5.
- If there is no continuity, replace the relay.
- (d) Install the No.3 cooling fan relay.