

## CO/HC INSPECTION

EM03T-02

### HINT:

This check is used only to determine whether or not the idle CO/HC complies with regulations.

#### 1. INITIAL CONDITIONS

- (a) Engine at normal operating temperature
- (b) Air cleaner installed
- (c) All pipes and hoses of air induction system connected
- (d) All accessories switched OFF
- (e) All vacuum lines properly connected
- (f) SFI system wiring connectors fully plugged
- (g) Ignition timing check correctly
- (h) Transmission in neutral position
- (i) Tachometer and CO/HC meter calibrated by hand

#### 2. START ENGINE

#### 3. RACE ENGINE AT 2,500 RPM FOR APPROX. 180 SECONDS

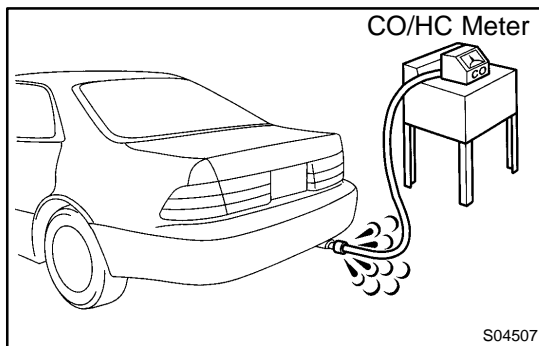

#### 4. INSERT CO/HC METER TESTING PROBE AT LEAST 40 cm (1.3 ft) INTO TAILPIPE DURING IDLING

#### 5. IMMEDIATELY CHECK CO/HC CONCENTRATION AT IDLE AND/OR 2,500 RPM

### HINT:

When doing the 2 mode (idle and 2,500 rpm) test, these measurement order prescribed by the applicable local regulations.

If the CO/HC concentration does not comply with regulations, troubleshoot in the order given below.  
See the table below for possible causes, and then inspect and correct the applicable causes if necessary.

CO	HC	Problems	Causes
Normal	High	Rough idle	1. Faulty ignitions: <ul style="list-style-type: none"> <li>● Incorrect timing</li> <li>● Fouled, shorted or improperly gapped plugs</li> </ul> 2. Incorrect valve clearance 3. Leaky intake and exhaust valves 4. Leaky cylinders
Low	High	Rough idle (Fluctuating HC reading)	1. Vacuum leaks: <ul style="list-style-type: none"> <li>● PCV hoses</li> <li>● Intake manifold</li> <li>● Air intake chamber</li> <li>● Throttle body</li> <li>● IAC valve</li> <li>● Break booster line</li> </ul> 2. Lean mixture causing misfire
High	High	Rough idle (Black smoke from exhaust)	1. Restricted air filter 2. Plugged PCV valve 3. Faulty SFI systems: <ul style="list-style-type: none"> <li>● Faulty pressure regulator</li> <li>● Defective ECT sensor</li> <li>● Faulty ECM</li> <li>● Faulty injectors</li> <li>● Faulty throttle position sensor</li> <li>● Faulty MAF meter</li> </ul>

# COMPRESSION INSPECTION

EM03U-02

## HINT:

If there is lack of power, excessive oil consumption or poor fuel economy, measure the compression pressure.

### 1. WARM UP AND STOP ENGINE

Allow the engine to warm up to normal operating temperature.

### 2. REMOVE IGNITION COILS (See page IG-5)

### 3. REMOVE SPARK PLUGS

Using a 16 mm plug wrench, remove the 6 spark plugs.

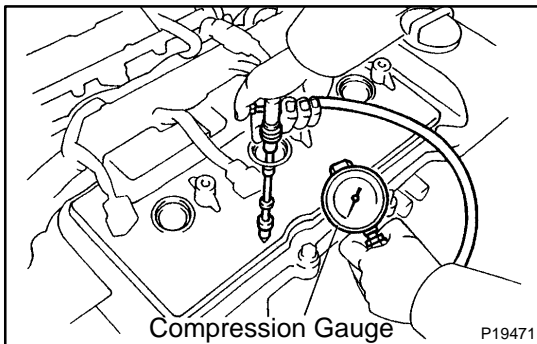

### 4. CHECK CYLINDER COMPRESSION PRESSURE

- (a) Insert a compression gauge into the spark plug hole.
- (b) Fully open the throttle.
- (c) While cranking the engine, measure the compression pressure.

## HINT:

Always use a fully charged battery to obtain engine speed of 250 rpm or more.

- (d) Repeat steps (a) through (c) for each cylinder.

## NOTICE:

**This measurement must be done in as short a time as possible.**

### Compression pressure:

**1,500 kPa (15.3 kgf/cm<sup>2</sup>, 218 psi)**

**Minimum pressure: 1,000 kPa (10.2 kgf/cm<sup>2</sup>, 145 psi)**

### Difference between each cylinder:

**100 kPa (1.0 kgf/cm<sup>2</sup>, 15 psi) or less**

- (e) If the cylinder compression in 1 or more cylinders is low, pour a small amount of engine oil into the cylinder through the spark plug hole and repeat steps (a) through (c) for cylinders with low compression.
  - If adding oil helps the compression, it is likely that the piston rings and/or cylinder bore are worn or damaged.
  - If pressure stays low, a valve may be sticking or seating is improper, or there may be leakage past the gasket.

### 5. REINSTALL SPARK PLUGS

### 6. INSTALL IGNITION COILS (See page IG-5)

# VALVE CLEARANCE INSPECTION

EM03V-02

## HINT:

Inspect and adjust the valve clearance when the engine is cold.

1. **REMOVE RH FENDER APRON SEAL**
2. **DRAIN ENGINE COOLANT**
3. **REMOVE V-BANK COVER**
  - (a) Using a 5 mm hexagon wrench, remove the 3 cap nuts.
  - (b) Loosen the V-bank cover fastener counterclockwise.
  - (c) Remove the V-bank cover.
4. **REMOVE AIR INTAKE CHAMBER ASSEMBLY (See page EM-31)**
5. **REMOVE IGNITION COILS**
6. **DISCONNECT UPPER RADIATOR HOSE FROM WATER OUTLET**
7. **REMOVE CYLINDER HEAD COVERS (See page EM-31)**

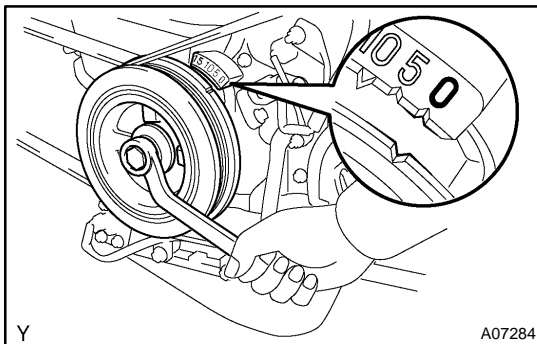

8. **SET NO.1 CYLINDER TO TDC/COMPRESSION**
  - (a) Turn the crankshaft pulley, and align its groove with the timing mark "0" of the No.1 timing belt cover.
  - (b) Check that the valve lifters on the No.1 (IN and EX) are loose.

If not, turn the crankshaft 1 revolution (360°) and align the mark as above.

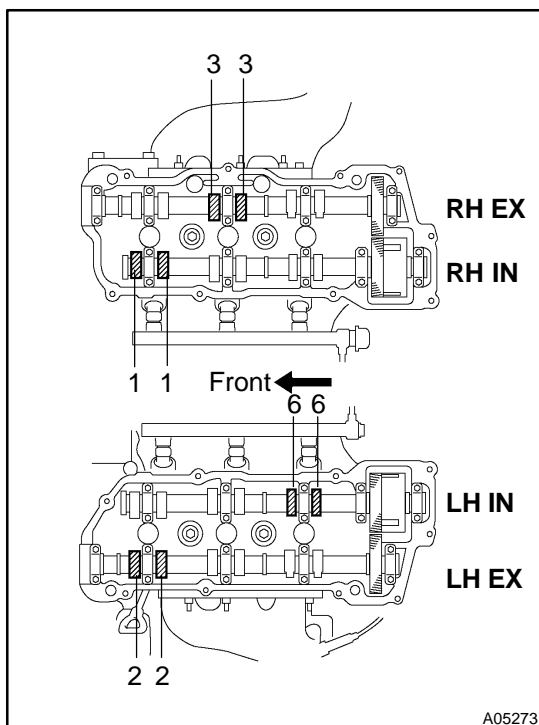

9. **INSPECT VALVE CLEARANCE**
  - (a) Check only those valves indicated in the illustration.
    - (1) Using a feeler gauge, measure the clearance between the valve lifter and camshaft.
    - (2) Record out of specification valve clearance measurements. They will be used later to determine the required replacement adjusting shim.

### Valve clearance (Cold):

Intake	0.15 – 0.25 mm (0.006 – 0.010 in.)
Exhaust	0.25 – 0.35 mm (0.010 – 0.014 in.)

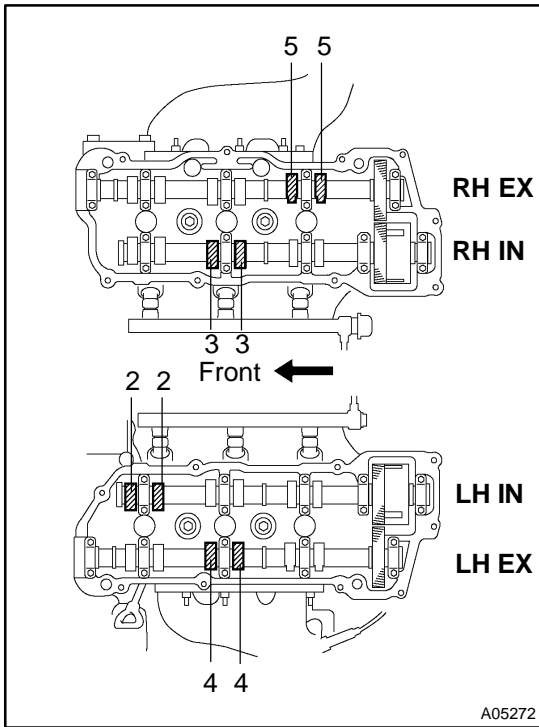

- (b) Turn the crankshaft  $2/3$  of a revolution ( $240^\circ$ ), and check only the valves indicated in the illustration. Measure the valve clearance (See step (a)).

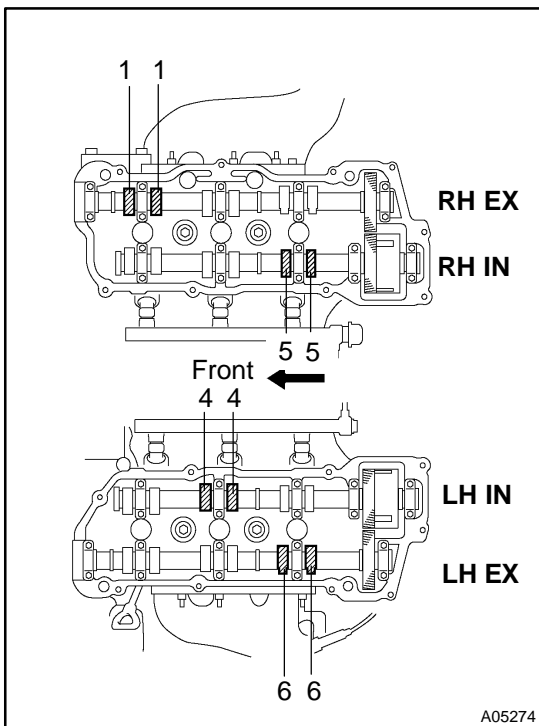

- (c) Turn the crankshaft a further  $2/3$  of a revolution ( $240^\circ$ ), and check only the valves indicated in the illustration. Measure the valve clearance (See step (a)).

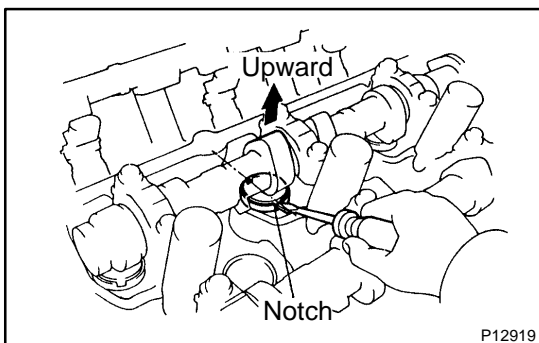

## 10. ADJUST VALVE CLEARANCE

- (a) Remove the adjusting shim.
- (1) Turn the camshaft so that the cam lobe for the valve to be adjusted faces up.
  - (2) Turn the valve lifter with a screwdriver so that the notches are perpendicular to the camshaft.

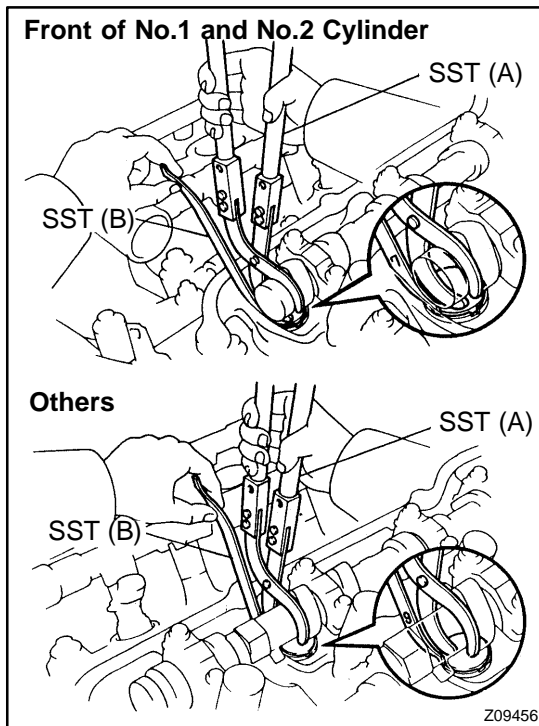

- (3) Using SST (A), press down the valve lifter and place SST (B) between the camshaft and valve lifter. Remove SST (A).

SST 09248-55040 (09248-05410, 09248-05420)

**HINT:**

- Apply SST (B) at a slight angle on the side marked with "9" or "7", at the position shown in the illustration.
- When SST (B) is inserted too deeply, it will get pinched by the shim. To prevent it from being stuck, insert it gently from the intake side, at a slight angle.

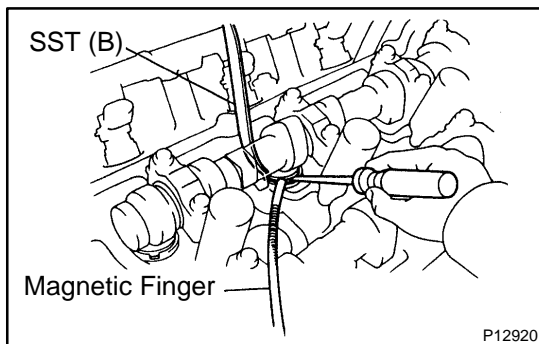

- Using a small screwdriver and magnetic finger, remove the adjusting shim.

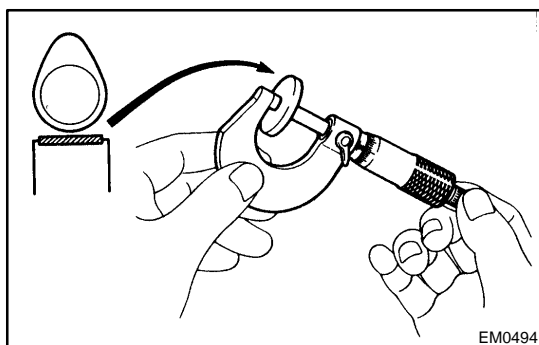

- (b) Determine the replacement adjusting shim size according to these Formula or Charts:

- (1) Using a micrometer, measure the thickness of the removed shim.
- (2) Calculate the thickness of a new shim so the valve clearance comes within the specified value.

**T** ..... Thickness of used shim

**A** ..... Measured valve clearance

**N** ..... Thickness of new shim

**Intake**

$$N = T + (A - 0.20 \text{ mm (0.008 in.)})$$

**Exhaust**

$$N = T + (A - 0.30 \text{ mm (0.012 in.)})$$

- (3) Select a new shim with a thickness as close as possible to the calculated values.

**HINT:**

Shims are available in 17 sizes in increments of 0.050 mm (0.0020 in.), from 2.500 mm (0.0984 in.) to 3.300 mm (0.1299 in.).

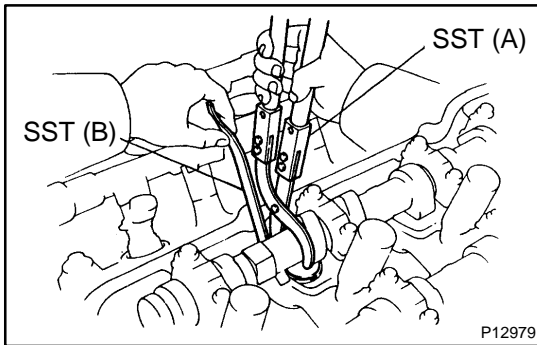

- (c) Install a new adjusting shim.
- (1) Place a new adjusting shim on the valve lifter, with imprinted numbers facing down.
  - (2) Press down the valve lifter with SST (A), and remove SST (B).

SST 09248-55040 (09248-05410, 09248-05420)

- (d) Recheck the valve clearance.

**11. REINSTALL CYLINDER HEAD COVERS**

(See page [EM-59](#))

**12. CONNECT UPPER RADIATOR HOSE TO WATER OUTLET**

**13. REINSTALL IGNITION COILS**

**14. REINSTALL AIR INTAKE CHAMBER ASSEMBLY (See page [EM-59](#))**

**15. INSTALL V-BANK COVER**

- (a) Using a 5 mm hexagon wrench, install the V-bank cover with the 3 cap nuts.

- (b) Press down the V-bank cover fastener.

**16. REFILL WITH ENGINE COOLANT**

**17. START ENGINE AND CHECK FOR LEAKS**

**18. REINSTALL RH FENDER APRON SEAL**





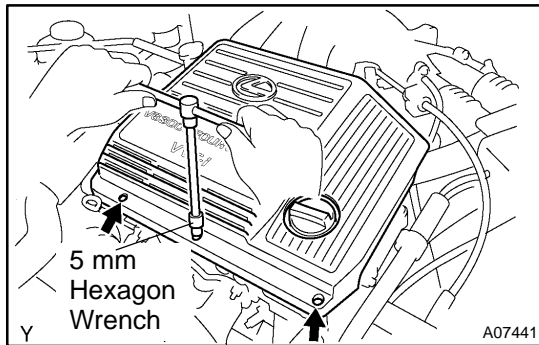

## IGNITION TIMING INSPECTION

EM02B-01

### 1. REMOVE V-BANK COVER

- Using a 5 mm hexagon wrench, remove the 3 cap nuts.
- Loosen the V-bank cover fastener counterclockwise.
- Remove the V-bank cover.

### 2. WARM UP ENGINE

Allow the engine to warm up to normal operating temperature.

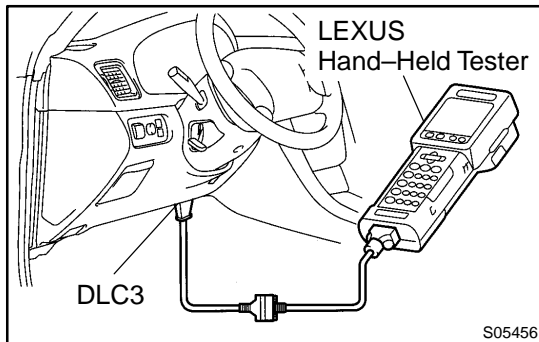

### 3. CONNECT LEXUS HAND-HELD TESTER OR OBDII SCAN TOOL

- Connect the LEXUS hand-held tester or OBDII scan tool to the DLC3.
- Please refer to the LEXUS hand-held tester or OBDII scan tool operator's manual for further details.

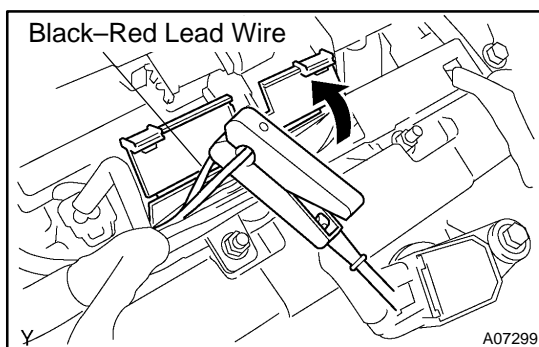

### 4. CONNECT TIMING LIGHT TO ENGINE

Connect the clip of a timing light to the black-red lead wire as shown.

### 5. CHECK IDLE SPEED

- Race the engine speed at 2,500 rpm for approx. 90 seconds.
- Check the idle speed.

**Idle speed: 700 ± 50 rpm**

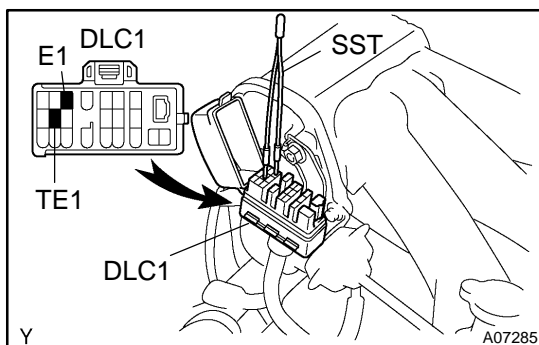

### 6. INSPECT IGNITION TIMING

- Using SST, connect terminals TE1 and E1 of the DLC1.  
SST 09843-18020

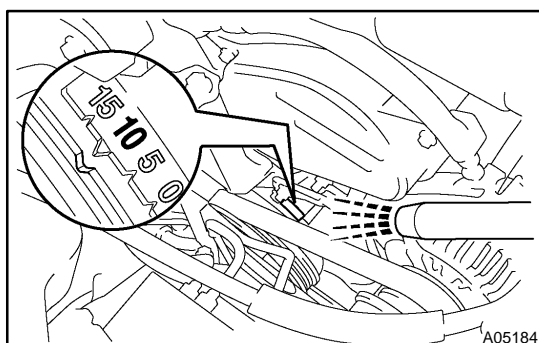

- Using a timing light, check the ignition timing.

**Ignition timing: 8 – 12° BTDC @ idle  
(Transmission in neutral position)**

- Remove the SST from the DLC1.  
SST 09843-18020

**7. FURTHER CHECK IGNITION TIMING**

**Ignition timing: 10 – 25° BTDC @ idle  
(Transmission in neutral position)**

**HINT:**

The timing mark moves in a range between 10° and 25°.

**8. DISCONNECT TIMING LIGHT FROM ENGINE****9. DISCONNECT LEXUS HAND-HELD TESTER OR  
OBDII SCAN TOOL****10. REINSTALL V-BANK COVER**

- (a) Using a 5 mm hexagon wrench, install the V-bank cover with the 3 cap nuts.
- (b) Press down the V-bank cover fastener.

# IDLE SPEED

## INSPECTION

EM03X-02

### 1. INITIAL CONDITIONS

- (a) Engine at normal operating temperature
- (b) Air cleaner installed
- (c) All pipes and hoses of air induction system connected
- (d) All accessories switched OFF
- (e) All vacuum lines properly connected
- (f) SFI system wiring connectors fully plugged
- (g) Ignition timing check correctly
- (h) Transmission in neutral position

### 2. CONNECT LEXUS HAND-HELD TESTER OR OBDII SCAN TOOL (See page [EM-10](#))

### 3. INSPECT IDLE SPEED

- (a) Race the engine speed at 2,500 rpm for approx. 90 seconds.
- (b) Check the idle speed.

**Idle speed: 700 ± 50 rpm**

If the idle speed is not as specified, check the IAC valve and air intake system.

### 4. DISCONNECT LEXUS HAND-HELD TESTER OR OBDII SCAN TOOL

# TIMING BELT COMPONENTS

EM03Y-02

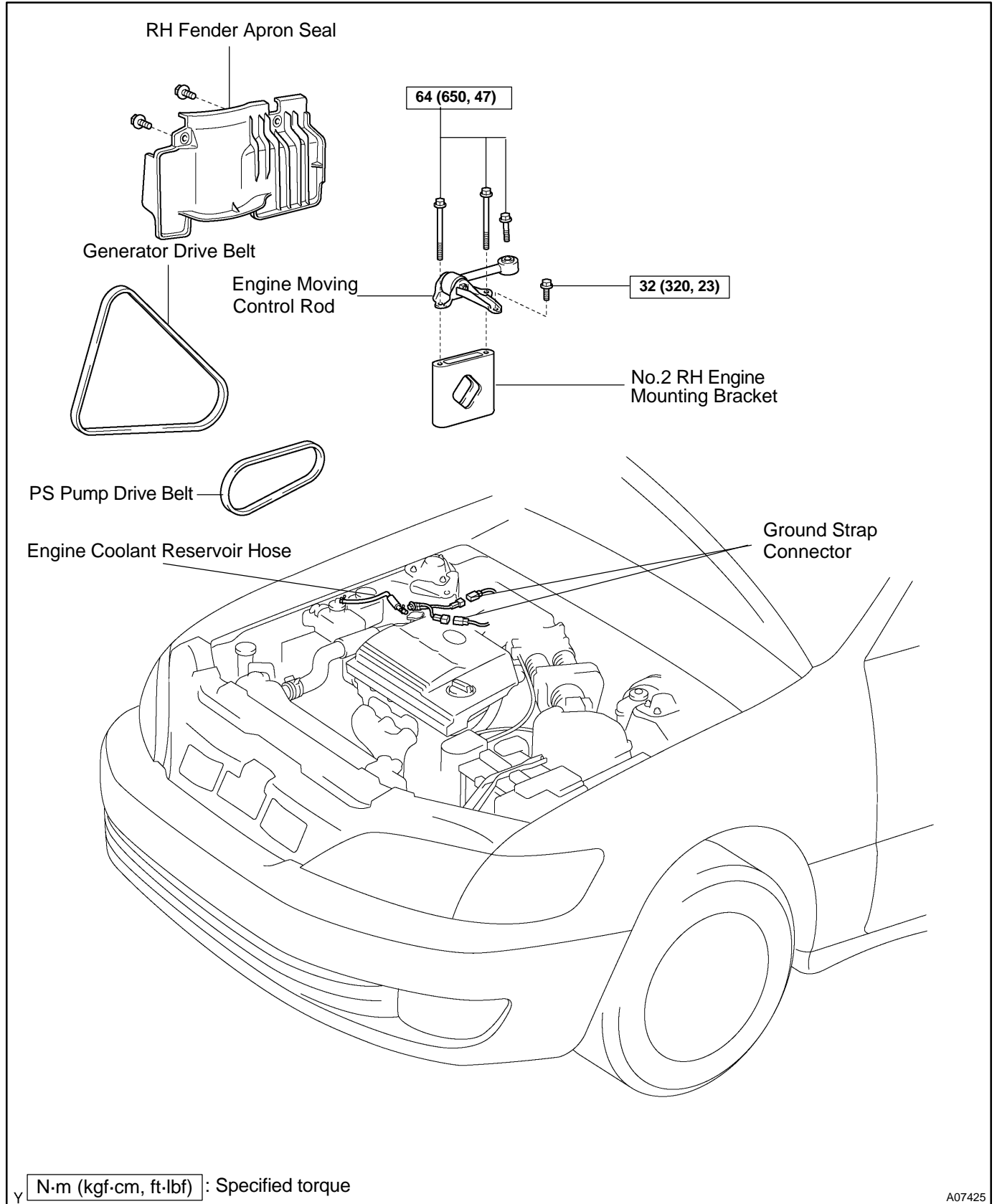

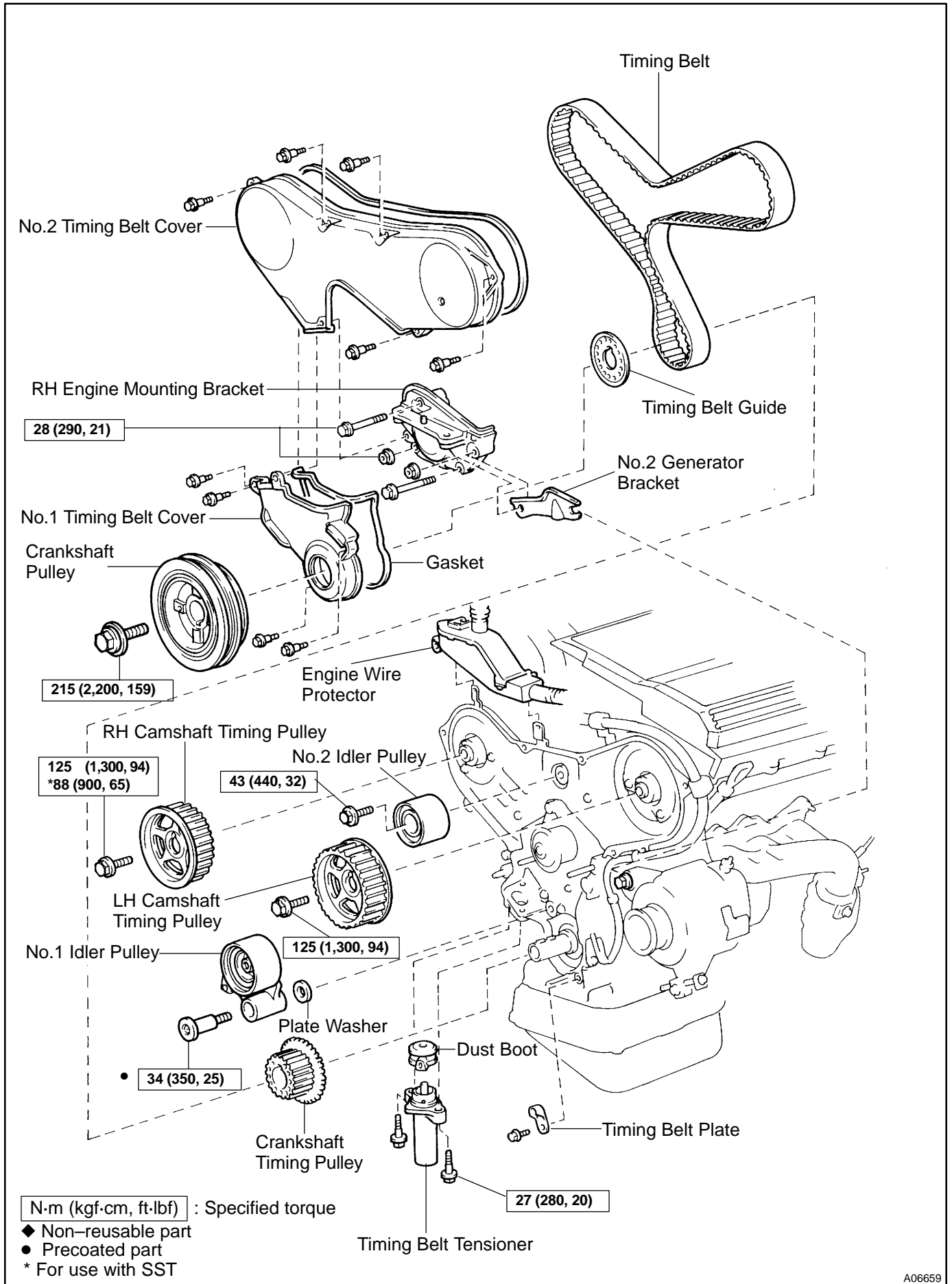

A06659

## REMOVAL

1. REMOVE RH FRONT WHEEL
2. REMOVE RH FENDER APRON SEAL
3. REMOVE GENERATOR DRIVE BELT  
(See page [CH-6](#))

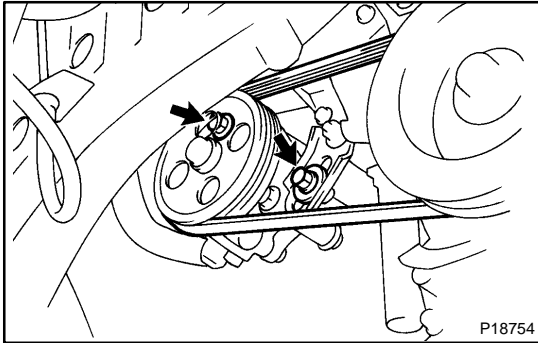

### 4. REMOVE PS PUMP DRIVE BELT

Loosen the 2 bolts, and remove the drive belt.

5. DISCONNECT ENGINE COOLANT RESERVOIR HOSE FROM WATER OUTLET
6. DISCONNECT GROUND STRAP CONNECTORS
7. REMOVE ENGINE MOVING CONTROL ROD AND NO.2 RH ENGINE MOUNTING BRACKET  
(See page [EM-72](#))

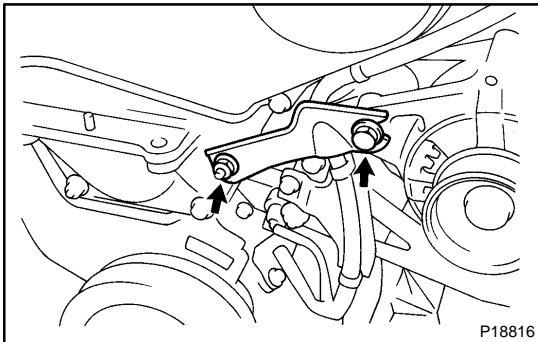

### 8. REMOVE NO.2 GENERATOR BRACKET

- (a) Loosen the generator pivot bolt.
- (b) Remove the nut and bracket.

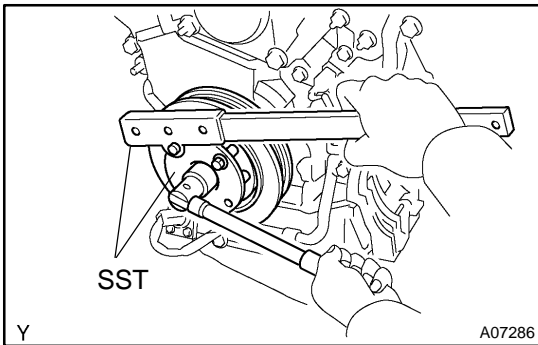

### 9. REMOVE CRANKSHAFT PULLEY

- (a) Using SST, remove the pulley bolt.  
SST 09213-54015 (91651-60855), 09330-00021

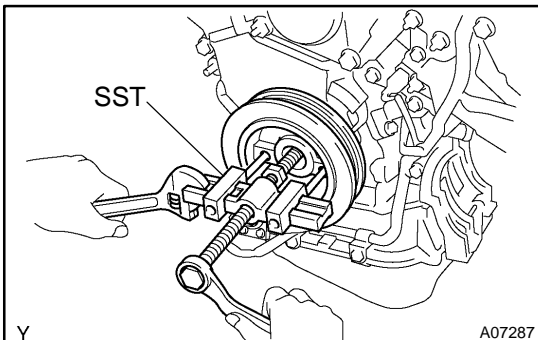

- (b) Using SST, remove the pulley.  
SST 09950-50012 (09951-05010, 09952-05010, 09953-05010, 09953-05020, 09954-05020)

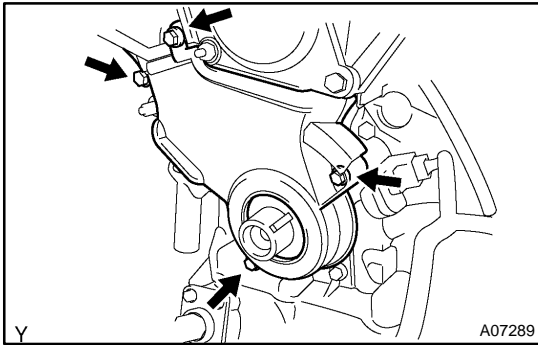
**10. REMOVE NO.1 TIMING BELT COVER**

Remove the 4 bolts and timing belt cover.

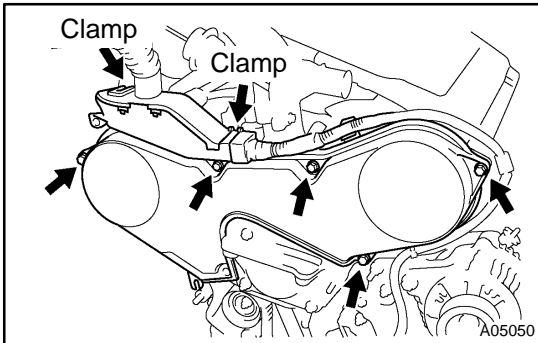
**11. REMOVE TIMING BELT GUIDE****12. REMOVE NO.2 TIMING BELT COVER**

(a) Disconnect the engine wire protector clamps from the No.3 timing belt cover.

(b) Remove the 5 bolts and timing belt cover.

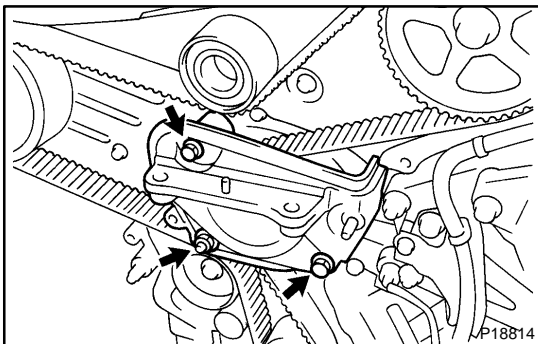
**13. REMOVE RH ENGINE MOUNTING BRACKET**

Remove the 2 bolts, nut and mounting bracket.

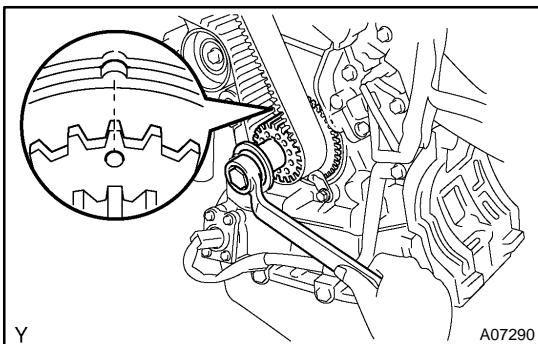
**14. SET NO.1 CYLINDER TO TDC/COMPRESSION**

(a) Temporarily install the crankshaft pulley bolt to the crankshaft.

(b) Turn the crankshaft, and align the timing marks of the crankshaft timing pulley and oil pump body.

**NOTICE:**

**Always turn the crankshaft clockwise.**

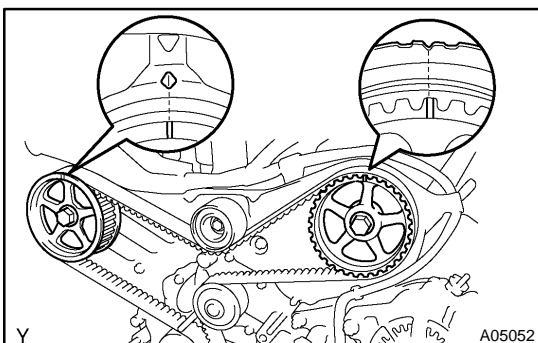

(c) Check that timing marks of the camshaft timing pulleys and No.3 timing belt cover are aligned.

If not, turn the crankshaft 1 revolution (360°).

(d) Remove the crankshaft pulley bolt.

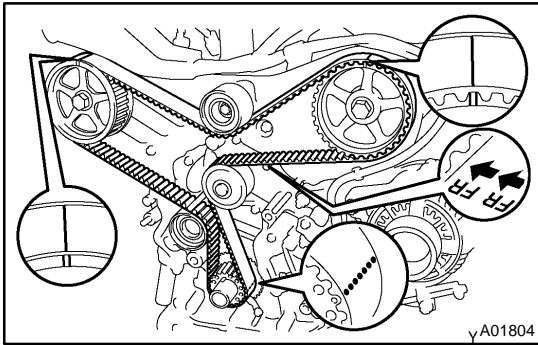

### 15. IF REUSING TIMING BELT, CHECK INSTALLATION MARKS ON TIMING BELT

Check that there are 3 installation marks and front mark on the timing belt.

If the installation and front marks have disappeared, before removing the timing belt, place 3 new installation marks on the timing belt to match the timing marks of the timing pulleys, and place a new front mark on the timing belt.

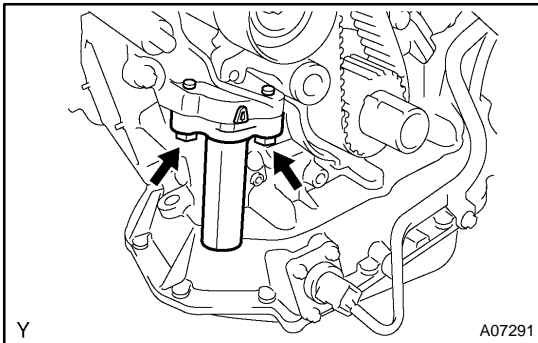

### 16. REMOVE TIMING BELT TENSIONER

Alternately loosen the 2 bolts, and remove them, the tensioner and dust boot.

### 17. REMOVE TIMING BELT

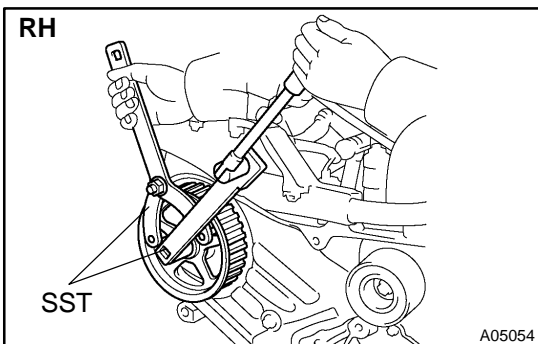

### 18. REMOVE CAMSHAFT TIMING PULLEYS

(a) Using SST, remove the bolt and RH timing pulley.

SST 09249-63010, 09960-10010 (09962-01000, 09963-01000)

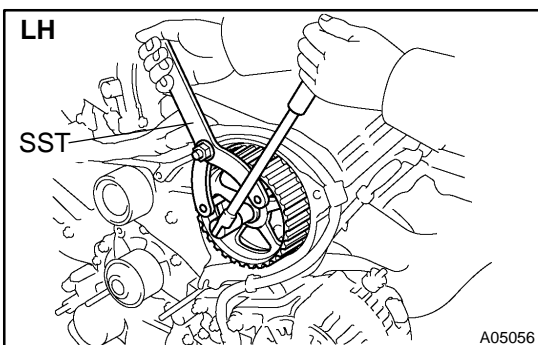

(b) Using SST, remove the LH timing pulley.

SST 09960-10010 (09962-01000, 09963-01000)

HINT:

Arrange the camshaft timing pulleys (RH and LH sides).

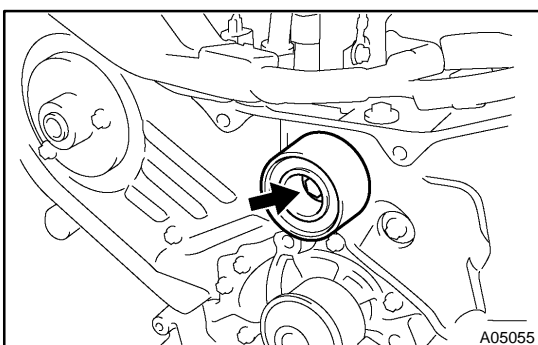

### 19. REMOVE NO.2 IDLER PULLEY

Remove the bolt and idler pulley.

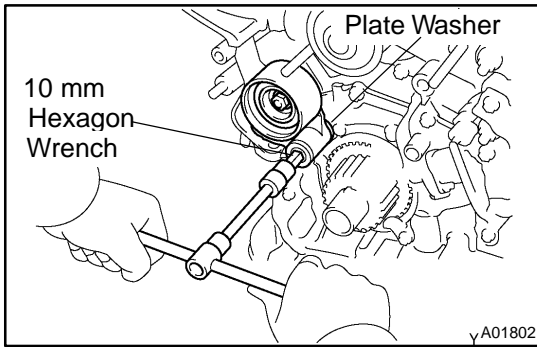
**20. REMOVE NO.1 IDLER PULLEY**

Using a 10 mm hexagon wrench, remove the bolt, idler pulley and plate washer.

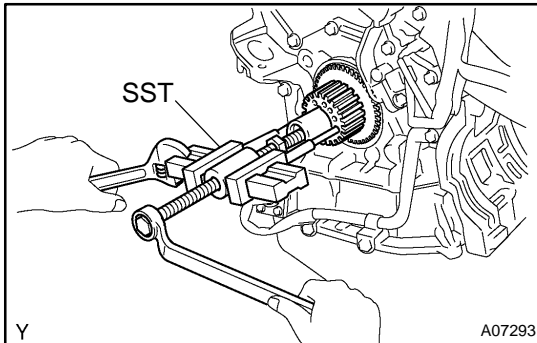
**21. REMOVE CRANKSHAFT TIMING PULLEY**

- (a) Remove the bolt and timing belt plate.
- (b) Using SST, remove the crankshaft timing pulley.

SST 09950-50012 (09951-05010, 09952-05010, 09953-05010, 09953-05020, 09954-05010)

**NOTICE:**

**Do not scratch the sensor part of the crankshaft timing pulley.**

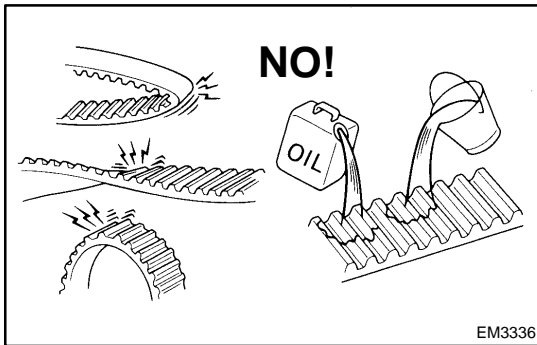

## INSPECTION

### 1. INSPECT TIMING BELT

#### NOTICE:

- Do not bend, twist or turn the timing belt inside out.
- Do not allow the timing belt to come into contact with oil, water or steam.
- Do not utilize timing belt tension when installing or removing the mount bolt of the camshaft timing pulley.

If there are any defects, as shown in the illustrations, check these points:

- (a) Premature parting
  - Check for proper installation.
  - Check the timing cover gasket for damage and proper installation.
- (b) If the belt teeth are cracked or damaged, check to see if either camshaft is locked.
- (c) If there is noticeable wear or cracks on the belt face, check to see if there are nicks on the side of the idler pulley lock and water pump.
- (d) If there is wear or damage on only one side of the belt, check the belt guide and the alignment of each pulley.
- (e) If there is noticeable wear on the belt teeth, check timing cover for damage and check gasket has been installed correctly and for foreign material on the pulley teeth.

If necessary, replace the timing belt.

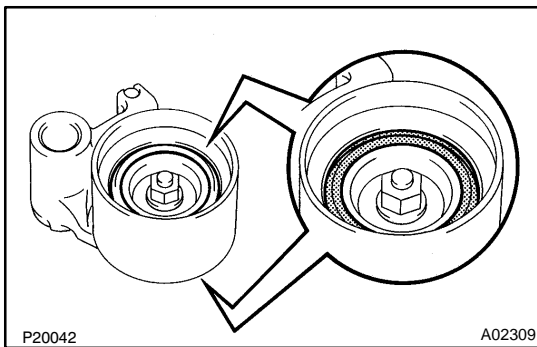

### 2. INSPECT IDLER PULLEYS

- (a) Visually check the seal portion of the idler pulley for oil leakage.

If leakage is found, replace the idler pulley.

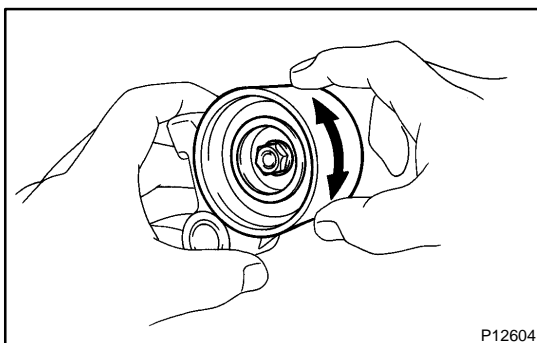

- (b) Check that the idler pulley turns smoothly.

If necessary, replace the idler pulley.

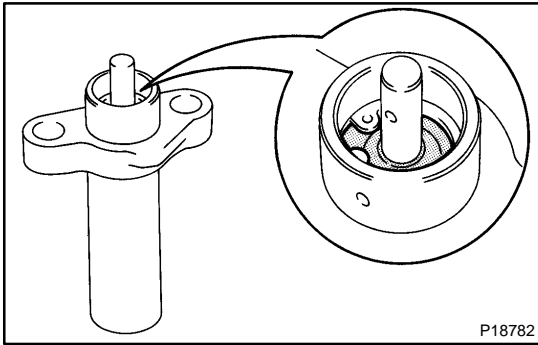

### 3. INSPECT TIMING BELT TENSIONER

- (a) Visually check the seal portion of the tensioner for oil leakage.

**HINT:**

If there is only the faintest trace of oil on the seal on the push rod side, the tensioner is all right.

If leakage is found, replace the tensioner.

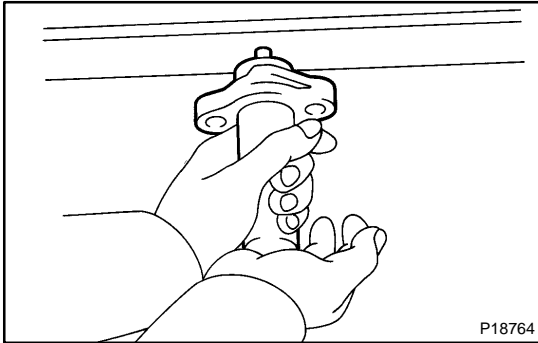

- (b) Hold the tensioner with both hands and push the push rod strongly as shown to check that it doesn't move.

If the push rod moves, replace the tensioner.

**NOTICE:**

**Never hold the tensioner push rod facing downward.**

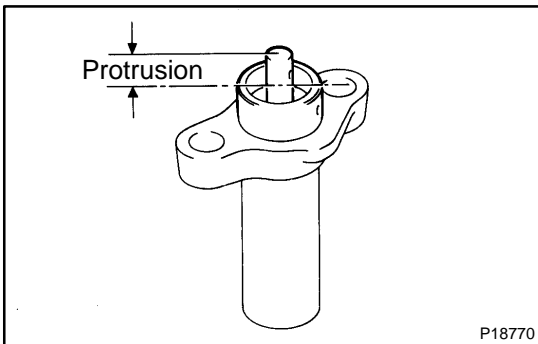

- (c) Measure the protrusion of the push rod from the housing end.

**Protrusion: 10.0 – 10.8 mm (0.394 – 0.425 in.)**

If the protrusion is not as specified, replace the tensioner.

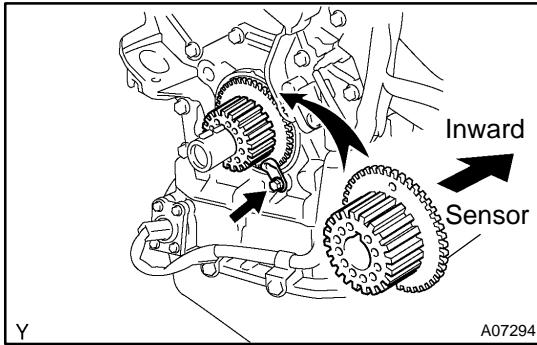

## INSTALLATION

### 1. INSTALL CRANKSHAFT TIMING PULLEY

- Align the pulley set key with the key groove of the timing pulley, and slide on the timing pulley.
- Install the timing pulley, facing the sensor side inward.

#### NOTICE:

**Do not scratch the sensor part of the crankshaft timing pulley.**

- Install the timing belt plate with the bolt.  
**Torque: 8 N·m (80 kgf·cm, 69 in.-lbf)**

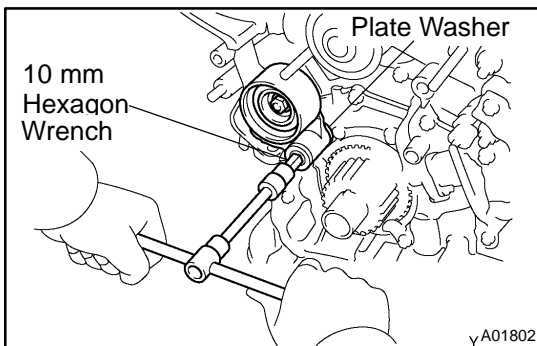

### 2. INSTALL NO.1 IDLER PULLEY

**Adhesive: Part No. 08833-00080, THREE BOND 1344, LOCTITE 242 or equivalent**

- Using a 10 mm hexagon wrench, install the plate washer and idler pulley with the pivot bolt.  
**Torque: 34 N·m (350 kgf·cm, 25 ft-lbf)**
- Check that the pulley bracket moves smoothly.

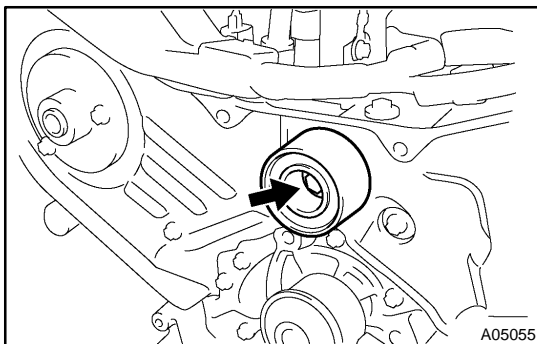

### 3. INSTALL NO.2 IDLER PULLEY

- Install the idler pulley with the bolt.  
**Torque: 43 N·m (440 kgf·cm, 32 ft-lbf)**
- Check that the idler pulley moves smoothly.

### 4. INSTALL RH CAMSHAFT TIMING PULLEY

- Face the flange side of the timing pulley outward.
- Align the knock pin on the camshaft with the knock pin groove of the timing pulley, and slide on the timing pulley.

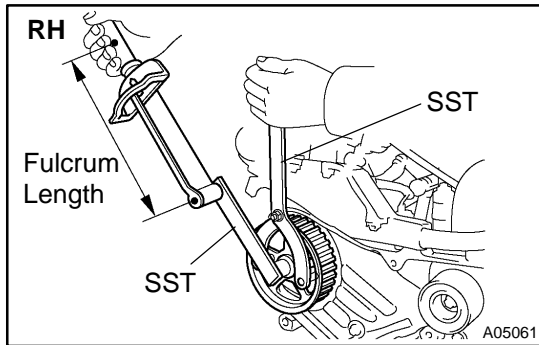

- (c) Using SST, install the pulley bolt.  
SST 09249-63010, 09960-10010 (09962-01000, 09963-01000)

**Torque: 88 N·m (900 kgf·cm, 65 ft·lbf)**

**HINT:**

Use a torque wrench with a fulcrum length of 340 mm (13.39 in.).

**5. INSTALL LH CAMSHAFT TIMING PULLEY**

- (a) Face the flange side of the timing pulley inward.  
(b) Align the knock pin on the camshaft with the knock pin groove of the timing pulley, and slide on the timing pulley.

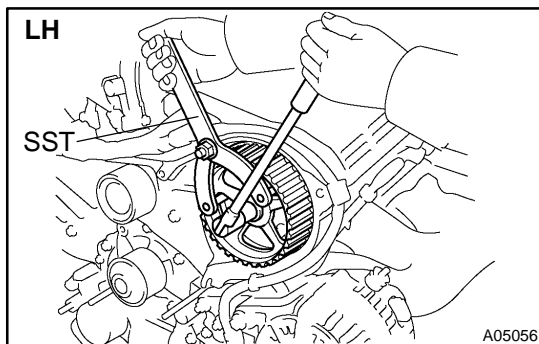

- (c) Using SST, install the pulley bolt.  
SST 09960-10010 (09962-01000, 09963-01000)  
**Torque: 125 N·m (1,300 kgf·cm, 94 ft·lbf)**

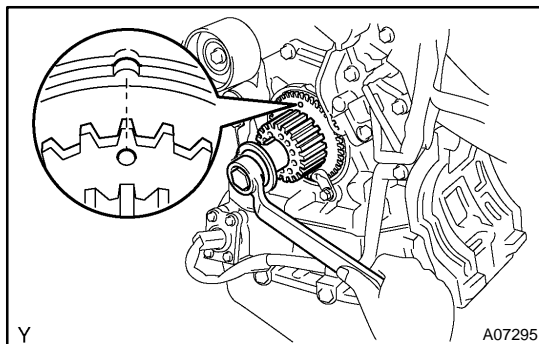

**6. SET NO.1 CYLINDER TO TDC/COMPRESSION**

- (a) Crankshaft Timing Pulley Position:  
(1) Temporarily install the crankshaft pulley bolt to the crankshaft.  
(2) Turn the crankshaft, and align the timing marks of the crankshaft timing pulley and oil pump body.

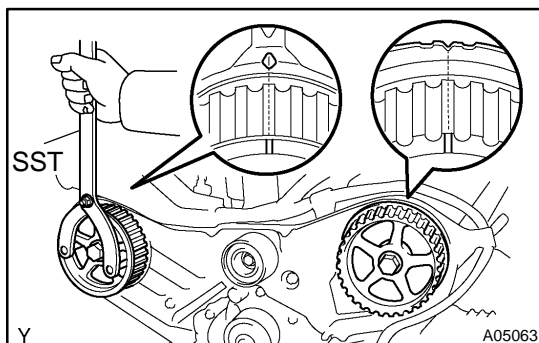

- (b) Camshaft Timing Pulley Positions:  
Using SST, turn the camshaft pulley, align the timing marks of the timing pulley and No.3 timing belt cover.  
SST 09960-10010 (09962-01000, 09963-01000)

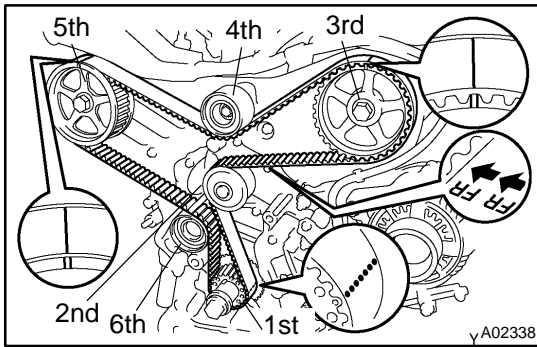

## 7. INSTALL TIMING BELT

### NOTICE:

The engine should be cold.

- (a) Remove any oil or water on the pulleys, and keep them clean.

### NOTICE:

Only wipe the pulleys; do not use any cleansing agent.

- (b) Face the front mark on the timing belt forward.
- (c) Align the installation mark on the timing belt with the timing mark of the crankshaft timing pulley.
- (d) Align the installation marks on the timing belt with the timing marks of the camshaft timing pulleys.
- (e) Install the timing belt in this order:
  - 1st: Crankshaft timing pulley
  - 2nd: Water pump pulley
  - 3rd: LH camshaft timing pulley
  - 4th: No.2 idler pulley
  - 5th: RH camshaft timing pulley
  - 6th: No.1 idler pulley

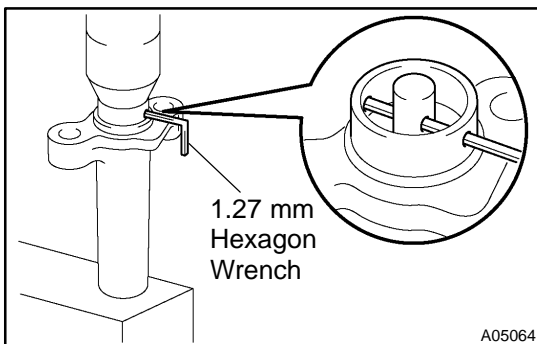

## 8. SET TIMING BELT TENSIONER

- (a) Using a press, slowly press in the push rod using 981 – 9,807 N (100 – 1,000 kgf, 200 – 2,205 lbf) of pressure.
- (b) Align the holes of the push rod and housing, pass a 1.27 mm hexagon wrench through the holes to keep the setting position of the push rod.
- (c) Release the press.

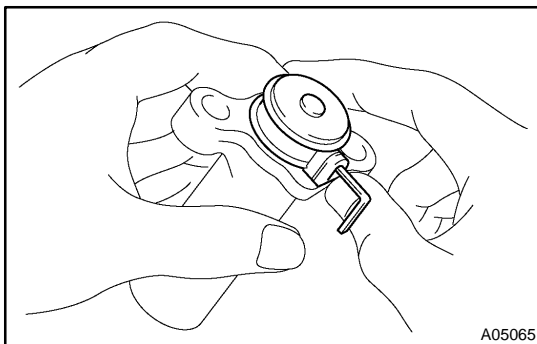

- (d) Install the dust boot to the tensioner.

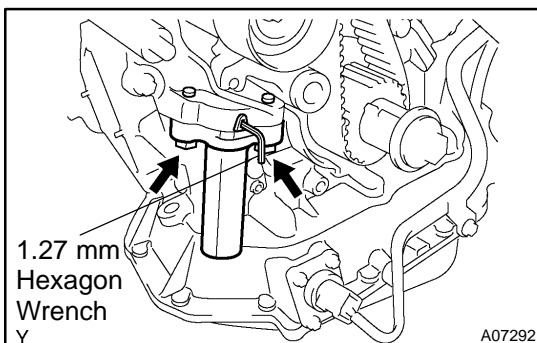

## 9. INSTALL TIMING BELT TENSIONER

- (a) Temporarily install the tensioner with the 2 bolts.
- (b) Alternately tighten the 2 bolts.  
**Torque: 27 N·m (280 kgf·cm, 20 ft·lbf)**
- (c) Remove the 1.27 mm hexagon wrench from the tensioner.

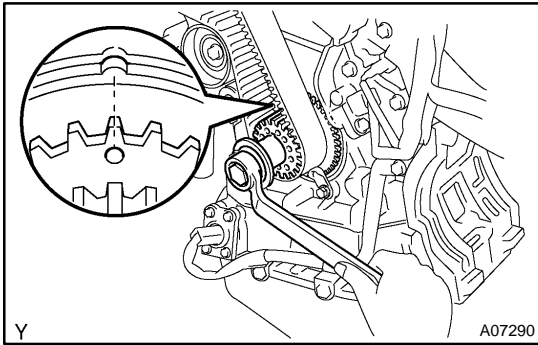

### 10. CHECK VALVE TIMING

- (a) Slowly turn the crankshaft 2 revolutions, and align the timing marks of the crankshaft timing pulley and oil pump body.

#### NOTICE:

**Always turn the crankshaft clockwise.**

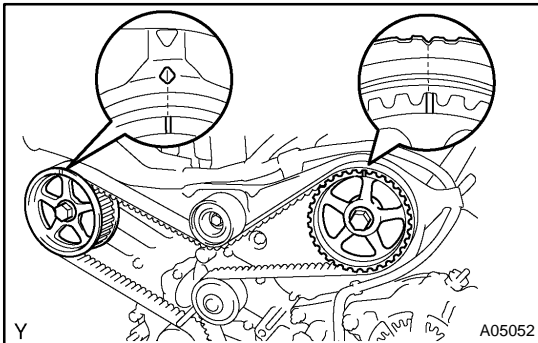

- (b) Check that the timing marks of the RH and LH timing pulleys with the timing marks of the No.3 timing belt cover as shown in the illustration.

If the marks do not align, remove the timing belt and reinstall it.

- (c) Remove the crankshaft pulley bolt.

### 11. INSTALL RH ENGINE MOUNTING BRACKET

**Torque: 28 N·m (290 kgf·cm, 21 ft·lbf)**

### 12. INSTALL NO.2 TIMING BELT COVER

- (a) Check that the timing belt cover gasket has no cracks or peeling, etc.

If the gasket has cracks or peeling, etc., replace it using these steps:

- Using a screwdriver and gasket scraper, remove all the old gasket material.
- Thoroughly clean all components to remove all the loose material.
- Remove the backing paper from a new gasket and install the gasket evenly to the part of the timing belt cover shaded black in the illustration.
- After installing the gasket, press down on it so that the adhesive firmly sticks to the timing belt cover.

- (b) Install the timing belt cover with the 5 bolts.

**Torque: 8.5 N·m (85 kgf·cm, 74 in.-lbf)**

- (c) Install the engine wire protector clamps to the No.3 timing belt cover.

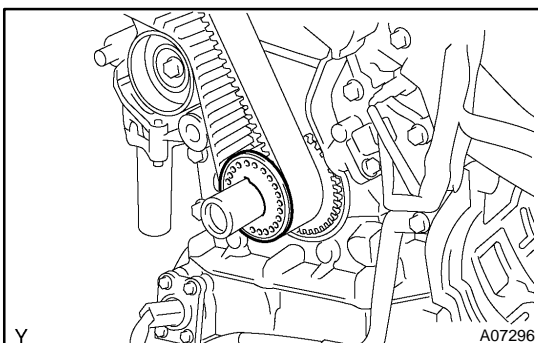
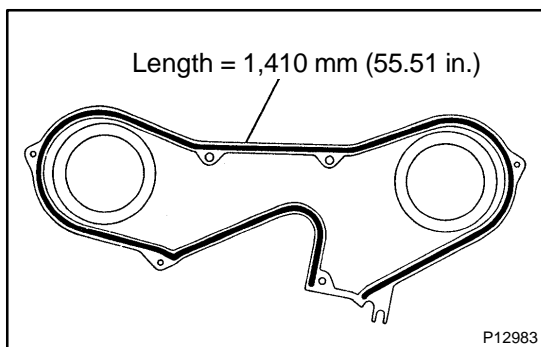

### 13. INSTALL TIMING BELT GUIDE

Install the timing belt guide, facing the cup side outward.

**14. INSTALL NO.1 TIMING BELT COVER**

- (a) Check that the timing belt cover gaskets have cracks or peeling, etc.

If the gasket has cracks or peeling, etc., replace it using these steps:

- Using a screwdriver and gasket scraper, remove all the old gasket material.
- Thoroughly clean all components to remove all the loose material.
- Remove the backing paper from a new gasket and install the gasket evenly to the part of the timing belt cover shaded black in the illustration.

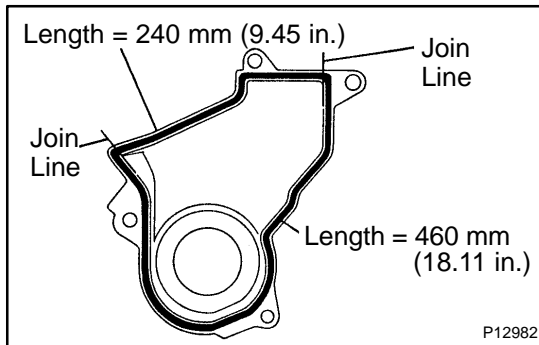
**NOTICE:**

**When joining 2 gaskets, do not leave a gap between them. Cut off any excess gasket.**

- After installing the gasket, press down on it so that the adhesive firmly sticks to the timing belt cover.

- (b) Install the timing belt cover with the 4 bolts.

**Torque: 8.5 N·m (85 kgf·cm, 74 in.-lbf)**

**15. INSTALL CRANKSHAFT PULLEY**

- (a) Align the pulley set key with the key groove of the pulley, and slide on the pulley.

- (b) Using SST, install the pulley bolt.

SST 09213-54015 (91651-60855), 09330-00021

**Torque: 215 N·m (2,200 kgf·cm, 159 ft-lbf)**

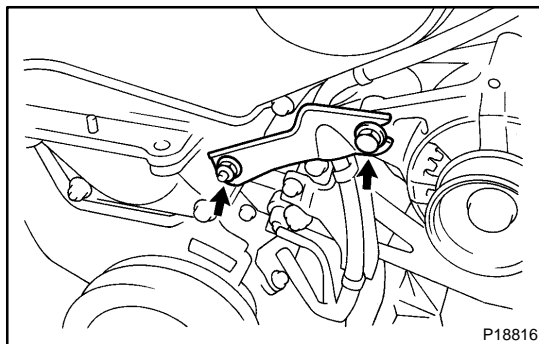
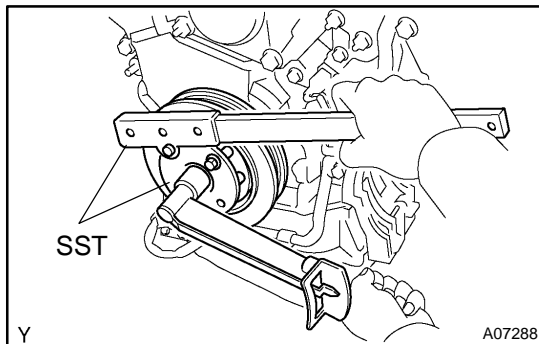
**16. INSTALL NO.2 GENERATOR BRACKET**

Install the generator bracket with the pivot bolt and nut. Do not tighten the bolt yet.

**Torque: (Nut): 28 N·m (290 kgf·cm, 21 ft-lbf)**

**17. INSTALL NO.2 RH ENGINE MOUNTING BRACKET AND ENGINE MOVING CONTROL ROD**

(See page [EM-77](#))

**18. CONNECT GROUND STRAP CONNECTORS****19. CONNECT ENGINE COOLANT RESERVOIR HOSE TO WATER OUTLET****20. INSTALL PS PUMP DRIVE BELT****21. INSTALL GENERATOR DRIVE BELT**

(See page [CH-16](#))

**22. INSTALL RH FENDER APRON SEAL****23. INSTALL RH FRONT WHEEL****24. VEHICLE ROAD TEST**

Check for abnormal noise, shock, slippage, correct shift points and smoothly operation.

# CYLINDER HEAD COMPONENTS

EM042-02

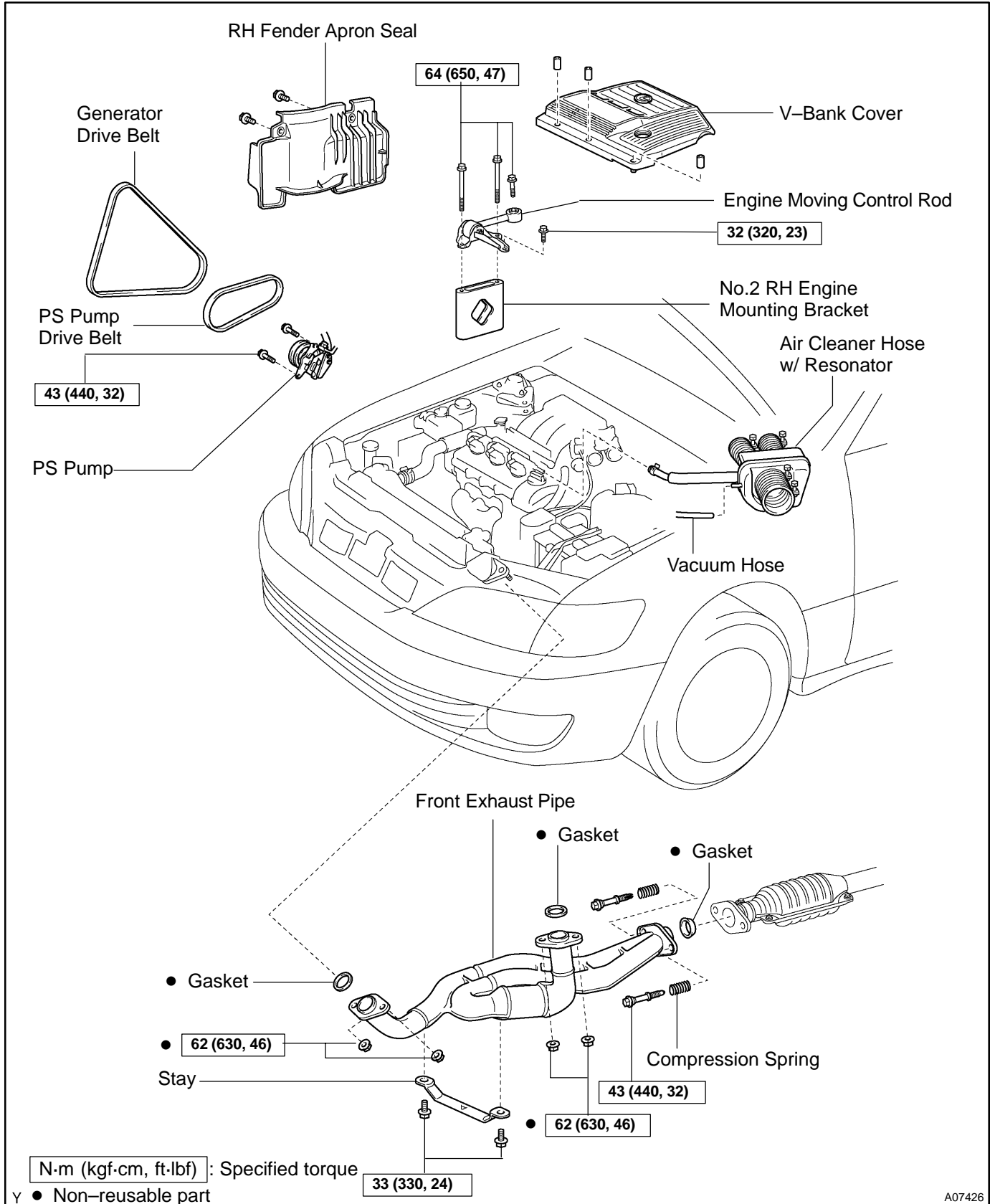

A07426



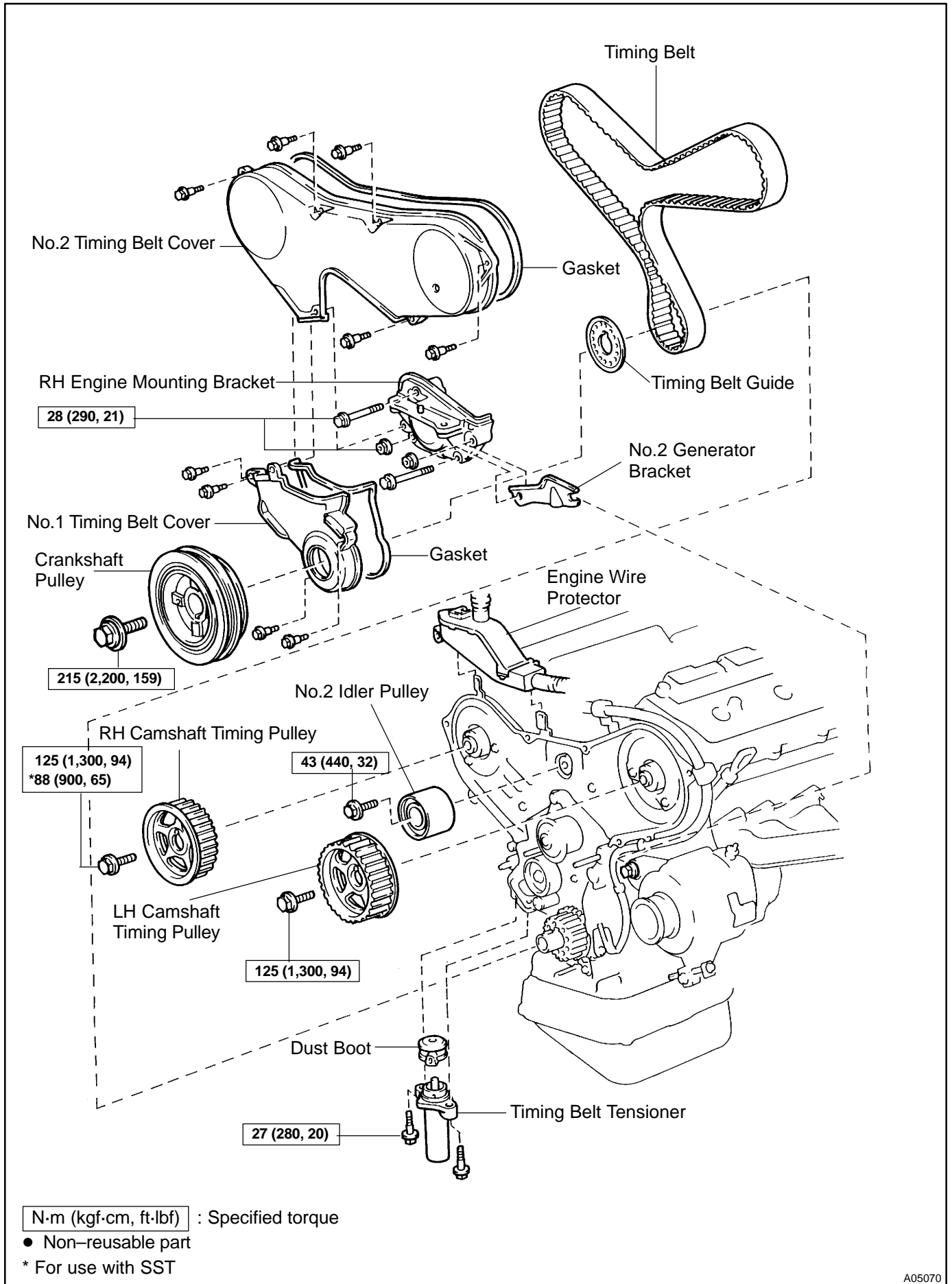



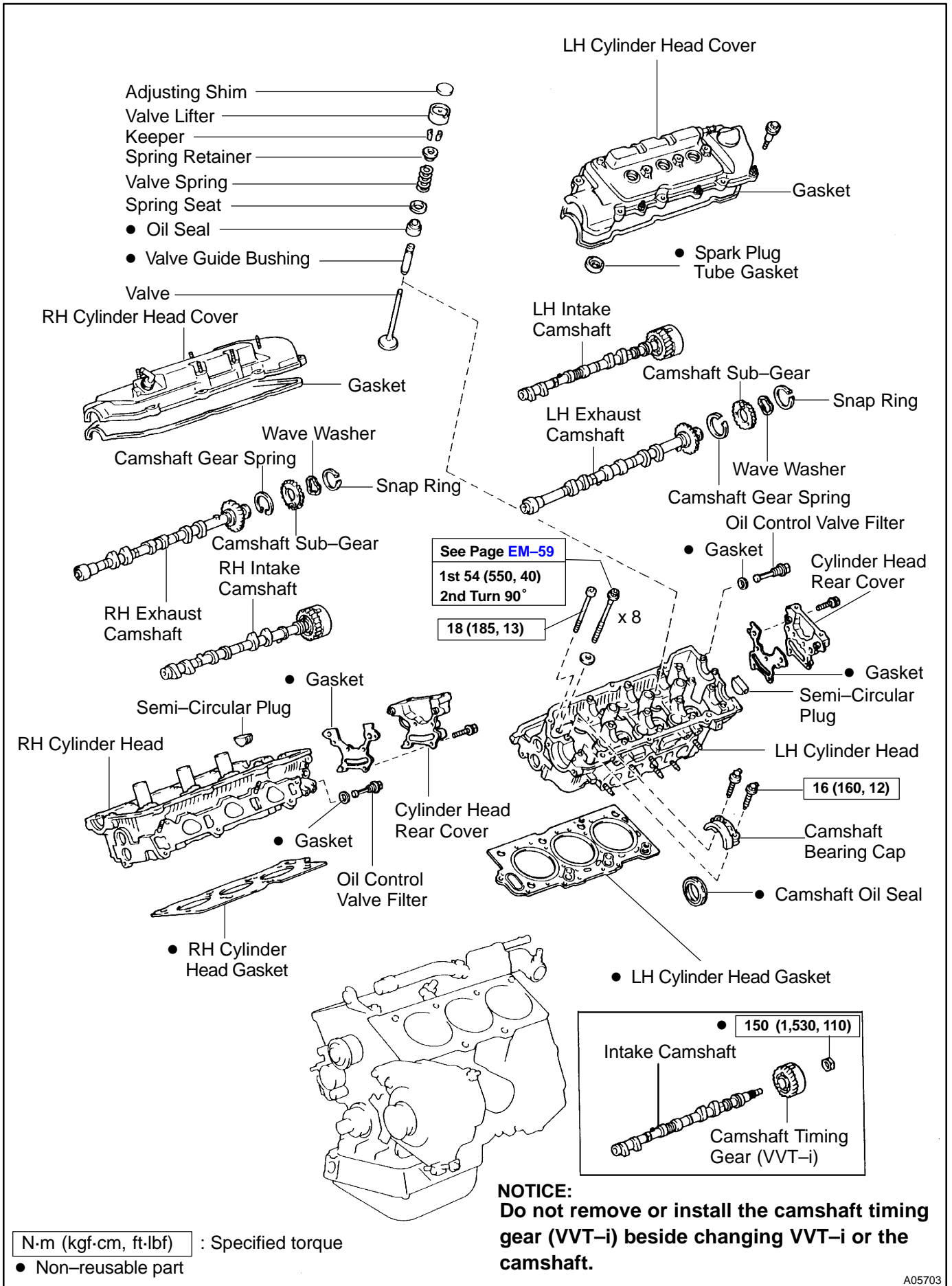

A05703

## REMOVAL

### NOTICE:

Do not remove or install the camshaft timing gear (VVT-i) beside changing VVT-i or the camshaft.

1. DRAIN ENGINE COOLANT
2. REMOVE RH FENDER APRON SEAL
3. REMOVE GENERATOR DRIVE BELT  
(See page [CH-6](#))
4. REMOVE PS PUMP (See page [SR-20](#))
5. REMOVE FRONT EXHAUST PIPE  
(See page [EM-72](#))

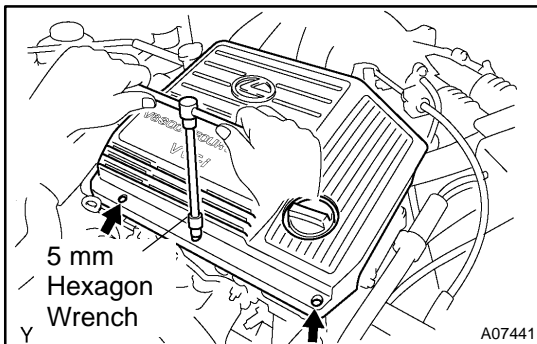

6. REMOVE V-BANK COVER
  - (a) Using a 5 mm hexagon wrench, remove the 3 cap nuts.
  - (b) Loosen the V-bank cover fastener counterclockwise.
  - (c) Remove the V-bank cover.
7. REMOVE AIR CLEANER CAP AND CASE ASSEMBLY  
(See page [EM-72](#))
8. REMOVE AIR INTAKE CHAMBER ASSEMBLY
  - (a) Disconnect the accelerator cable.
  - (b) Disconnect the throttle position sensor connector.
  - (c) Disconnect the IAC valve connector.
  - (d) Disconnect the No.1 VSV connector for the ACIS.
  - (e) Disconnect the No.2 VSV connector for the ACIS.
  - (f) Disconnect the VSV connector for the EVAP.
  - (g) Disconnect the DLC1 from the bracket on the intake air control valve.
  - (h) Remove the 2 nuts, and disconnect the PS pressure tube from the No.1 engine hanger.

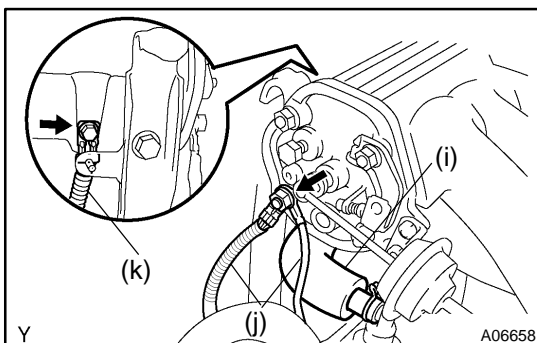

- (i) Disconnect the PCV hose from the PCV valve on the RH cylinder head.
- (j) Disconnect the ground strap and cable from the intake air control valve for the ACIS.
- (k) Disconnect the ground cable from the air intake chamber.

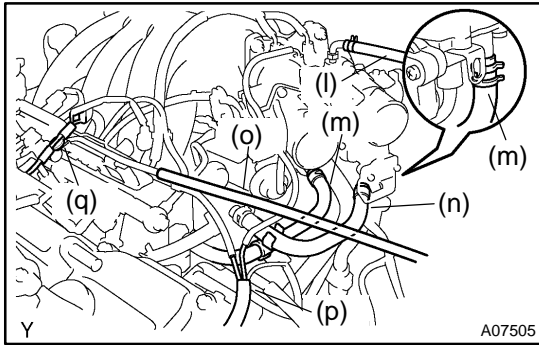

- (l) Disconnect the brake booster vacuum hose from the throttle body.
- (m) Disconnect the 2 water bypass hoses from the throttle body.
- (n) Disconnect the air assist hose from the throttle body.
- (o) Disconnect the purge hose from the pipe on the emission control valve set.
- (p) Disconnect the 2 vacuum hoses from the vacuum tank for the ACIS.
- (q) Disconnect the engine wire clamp from the emission control valve set.

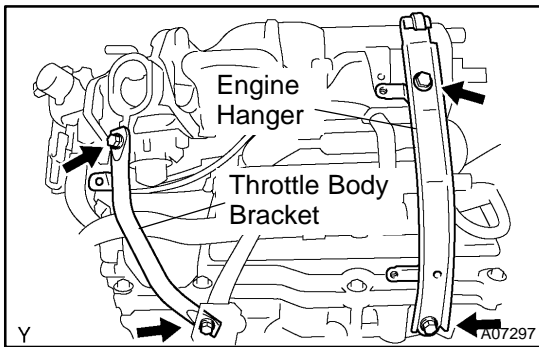

- (r) Remove the 2 bolts and No.1 engine hanger.
- (s) Remove the 2 bolts and throttle body bracket.

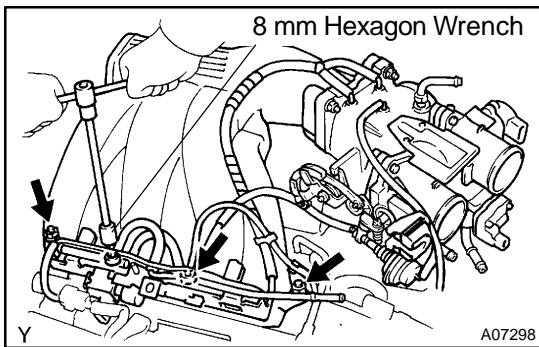

- (t) Using an 8 mm hexagon wrench, remove the 2 bolts, 2 nuts, the air intake chamber assembly and gasket.

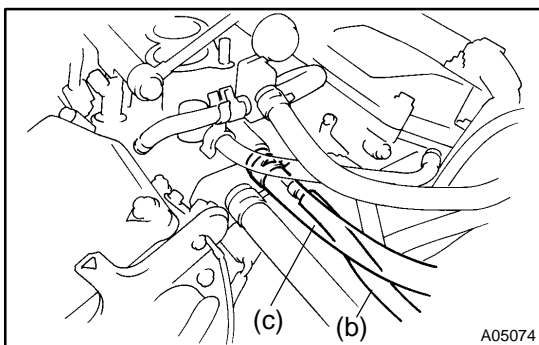

### 9. REMOVE INTAKE MANIFOLD ASSEMBLY

- (a) Disconnect the 6 injector connectors.
- (b) Disconnect the fuel inlet hose from the fuel filter.

#### CAUTION:

Perform connecting operations of the fuel tube connector (quick type) after observing the precautions.

(See page SF-1)

- (c) Disconnect the heater hose from the intake manifold.

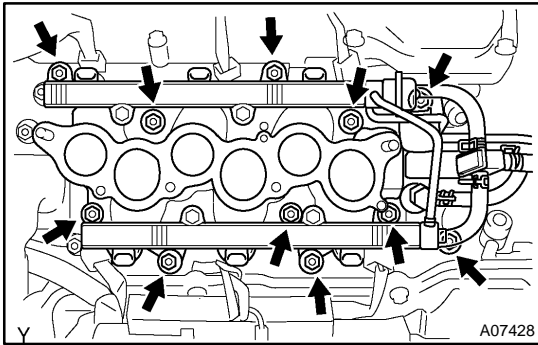

- (d) Remove the 9 bolts, 2 nuts, 2 plate washers, the intake manifold, delivery pipes and injectors assembly.

**NOTICE:**

- Be careful not to drop the injectors when removing the delivery pipes.
- Pay attention to put any hung load on the injector to and from the side direction.

**10. REMOVE WATER OUTLET**

- (a) Disconnect the ECT sender gauge connector.  
 (b) Disconnect the ECT sensor connector.  
 (c) Disconnect the ground strap connector.  
 (d) Disconnect the upper radiator hose.  
 (e) Disconnect the engine coolant reservoir hose.

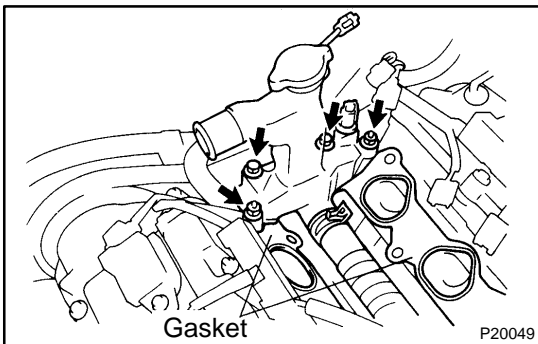

- (f) Remove the 2 bolts, 2 nuts and 2 plate washers.  
 (g) Disconnect the water bypass hose, and remove the water outlet.  
 (h) Remove the 2 gaskets.

**11. REMOVE IGNITION COILS****12. REMOVE SPARK PLUGS****13. REMOVE TIMING BELT (See page EM-15)****14. REMOVE CAMSHAFT TIMING PULLEYS (See page EM-15)****15. REMOVE NO.2 IDLER PULLEY (See page EM-15)****16. REMOVE NO.3 TIMING BELT COVER**

- (a) Disconnect the 3 engine wire clamps from the timing belt cover.

- (b) Remove the 6 bolts and timing belt cover.

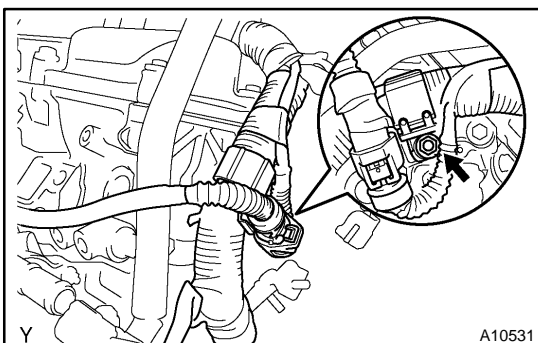
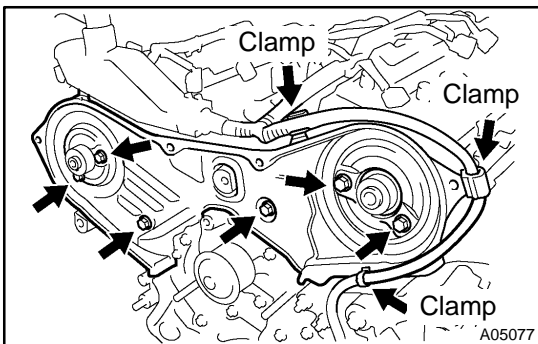
**17. REMOVE CAMSHAFT POSITION SENSORS****18. REMOVE CAMSHAFT TIMING OIL CONTROL VALVES****19. DISCONNECT ENGINE WIRE PROTECTOR FROM REAR SIDE**

Remove the nut, and disconnect the engine wire protector from the RH cylinder head.

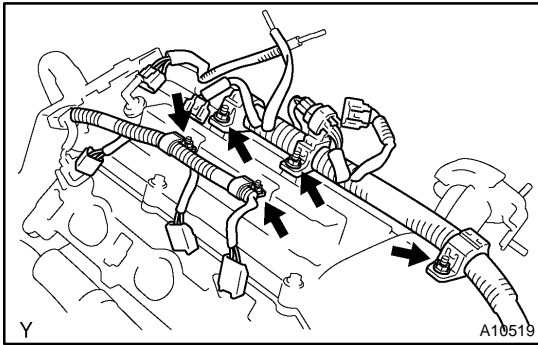

## 20. DISCONNECT ENGINE WIRE AND PROTECTOR FROM RH SIDE

Remove the 5 nuts, and disconnect the engine wire and protector from the RH cylinder head cover.

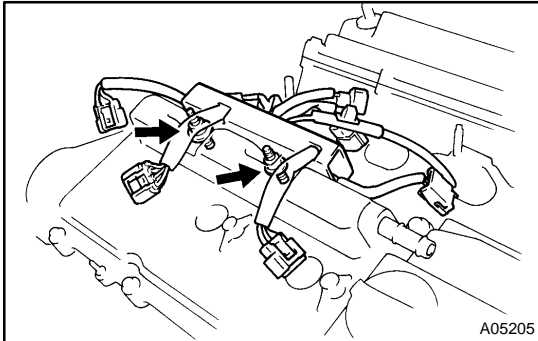

## 21. DISCONNECT ENGINE WIRE PROTECTOR FROM LH SIDE

Remove the 2 bolts, and disconnect the engine wire protector from the LH cylinder head cover.

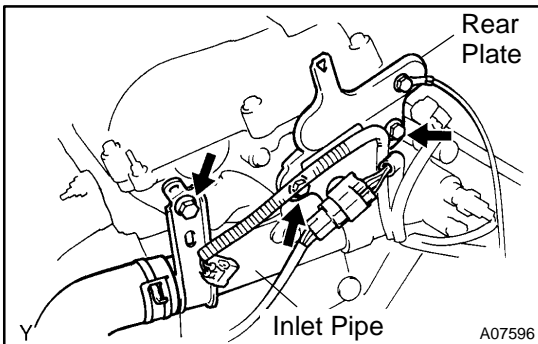

## 22. DISCONNECT CYLINDER HEAD REAR PLATE FROM LH CYLINDER HEAD

Remove the 2 bolts, and disconnect the rear plate.

## 23. DISCONNECT WATER INLET PIPE FROM LH CYLINDER HEAD AND WATER INLET

- (a) Remove the bolt, and disconnect the inlet pipe from the water inlet.
- (b) Remove the O-ring from the inlet pipe.

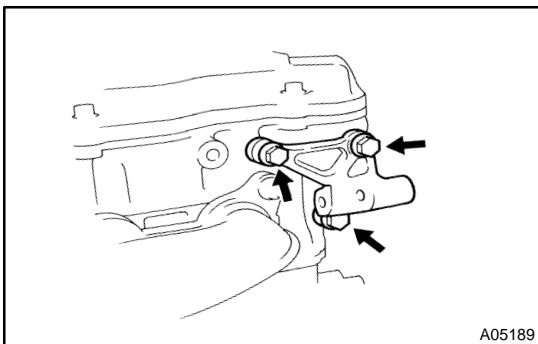

## 24. REMOVE PS PUMP BRACKET

Remove the 3 bolts and pump bracket.

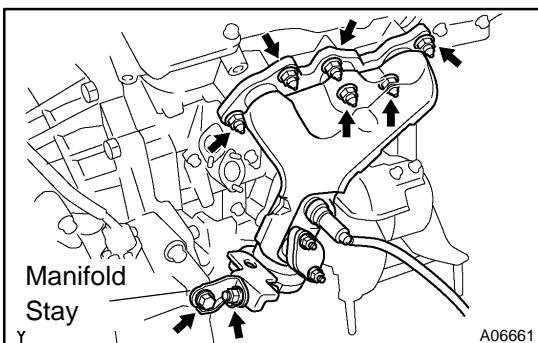

## 25. REMOVE RH EXHAUST MANIFOLD

- (a) Disconnect the A/F sensor connector.
- (b) Remove the bolt, nut and exhaust manifold stay.
- (c) Remove the 6 nuts, exhaust manifold and gasket.

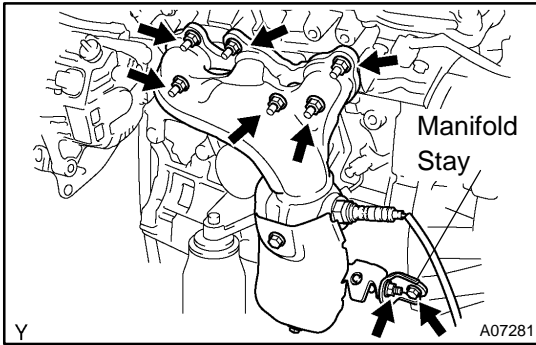
**26. REMOVE LH EXHAUST MANIFOLD**

- (a) Disconnect the A/F sensor connector.
- (b) Remove the bolt, nut and exhaust manifold stay.
- (c) Remove the 6 nuts, exhaust manifold and gasket.

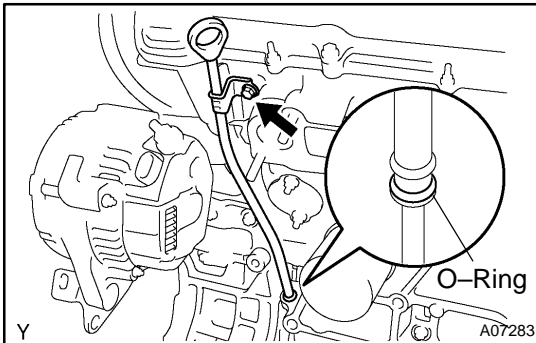
**27. REMOVE OIL DIPSTICK AND GUIDE**

- (a) Remove the bolt holding the dipstick guide to the LH cylinder head.
- (b) Pull out the dipstick guide together with the dipstick from the No.1 oil pan.
- (c) Remove the O-ring from the dipstick guide.

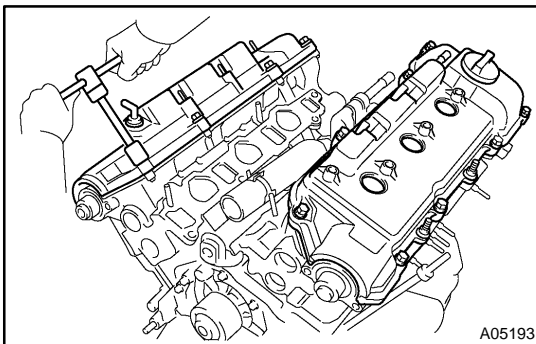
**28. REMOVE CYLINDER HEAD COVERS**

Remove the 9 bolts, cylinder head cover and gasket. Remove the 2 cylinder head covers.

**29. REMOVE CAMSHAFTS OF RH CYLINDER HEAD****NOTICE:**

Since the thrust clearance of the camshaft is small, the camshaft must be kept leveled while it is being installed. If the camshaft is not kept leveled, the portion of the cylinder head receiving the shaft thrust may crack or be damaged, causing the camshaft to seize or break. To avoid this, the following steps should be carried out.

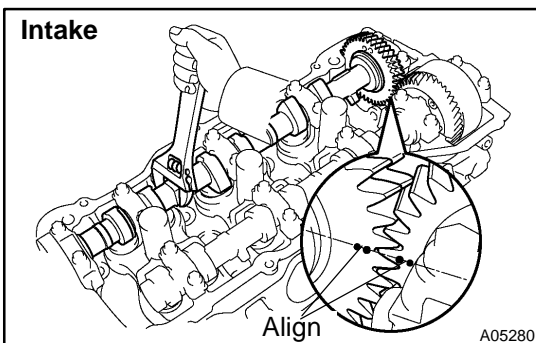

- (a) Remove the intake camshaft.
  - (1) Align the timing marks (2 dot marks) of the camshaft drive and driven gears by turning the camshaft with a wrench.

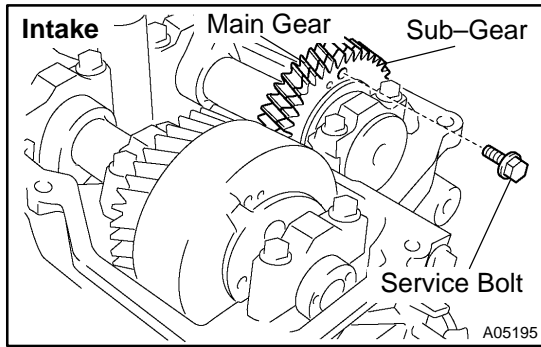

- (2) Secure the exhaust camshaft sub-gear to the main gear with a service bolt.

**Recommended service bolt:**

Thread diameter	6 mm
Thread pitch	1.0 mm
Bolt length	16 – 20 mm (0.63 – 0.79 in.)

**HINT:**

When removing the camshaft, mark certain that the torsional spring force of the sub-gear has been eliminated by the above operation.

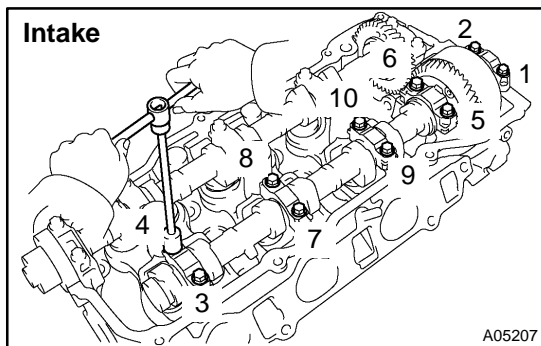

- (3) Uniformly loosen and remove the 10 bearing cap bolts in several passes and in the sequence shown.
- (4) Remove the 5 bearing caps and intake camshaft.

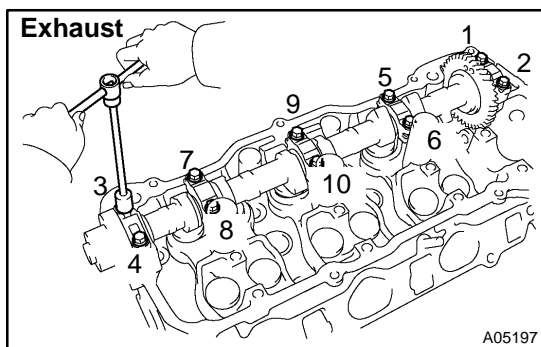

- (b) Remove the exhaust camshaft.
- (1) Uniformly loosen and remove the 10 bearing cap bolts in several passes and in the sequence shown.
- (2) Remove the 5 bearing caps, oil seal and exhaust camshaft.

### 30. REMOVE CAMSHAFTS OF LH CYLINDER HEAD

**NOTICE:**

Since the thrust clearance of the camshaft is small, the camshaft must be kept leveled while it is being installed. If the camshaft is not kept leveled, the portion of the cylinder head receiving the shaft thrust may crack or be damaged, causing the camshaft to seize or break. To avoid this, the following steps should be carried out.

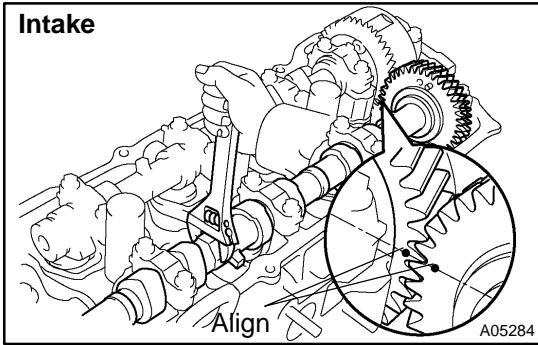

- (a) Remove the intake camshaft.
- (1) Align the timing marks (1 dot mark) of the camshaft drive and driven gears by turning the camshaft with a wrench.

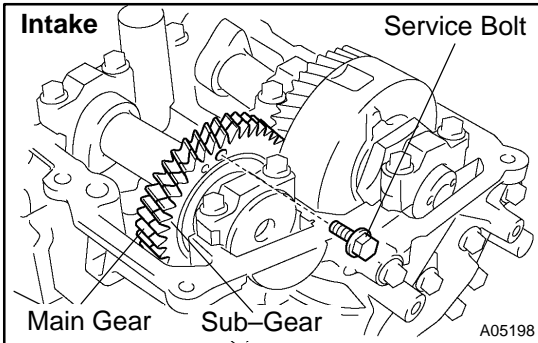

- (2) Secure the exhaust camshaft sub-gear to the main gear with a service bolt.

**Recommended service bolt:**

Thread diameter	6 mm
Thread pitch	1.0 mm
Bolt length	16 - 20 mm (0.63 - 0.79 in.)

**HINT:**

When removing the camshaft, make sure that the torsional spring force of the sub-gear has been eliminated by the above operation.

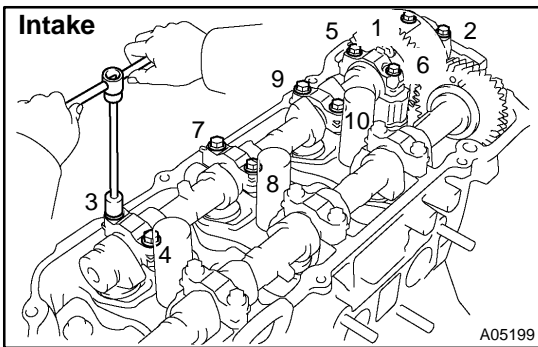

- (b) Uniformly loosen and remove the 10 bearing cap bolts in several passes and in the sequence shown.
- (c) Remove the 5 bearing caps and intake camshaft.

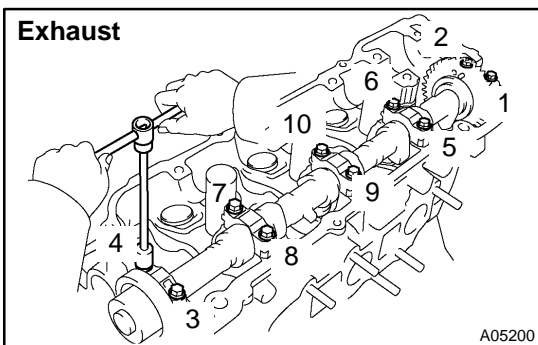

- (d) Remove the exhaust camshaft.

  - (1) Uniformly loosen and remove the 10 bearing cap bolts in several passes and in the sequence shown.
  - (2) Remove the 5 bearing caps, oil seal and exhaust camshaft.

**HINT:**

- Arrange the camshafts in the correct order.
- Arrange the bearing caps in the correct order.

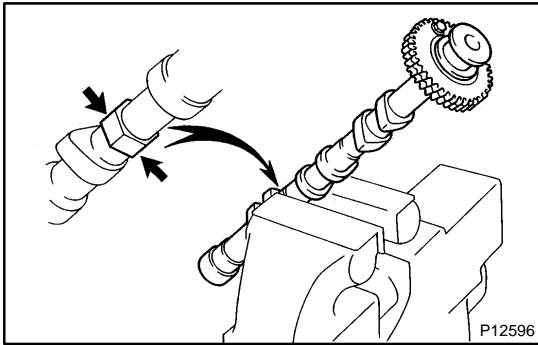

### 31. DISASSEMBLE EXHAUST CAMSHAFTS

- (a) Mount the hexagonal wrench head portion of the camshaft in a vise.

**NOTICE:**

**Be careful not to damage the camshaft.**

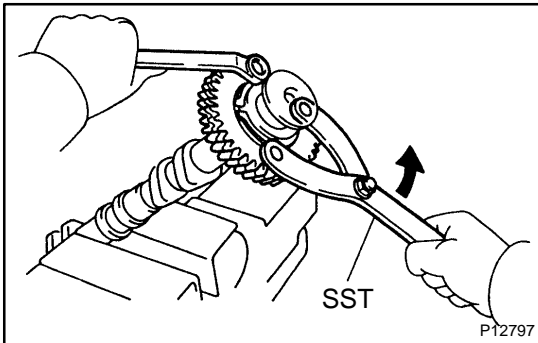

- (b) Using SST, turn the sub-gear counterclockwise, and remove the service bolt.

SST 09960-10010 (09962-01000, 09963-00500)

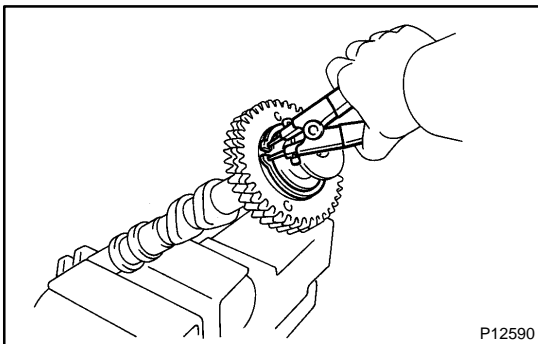

- (c) Using snap ring pliers, remove the snap ring.

- (d) Remove the wave washer, camshaft sub-gear, and camshaft gear spring.

**HINT:**

Arrange the camshaft sub-gears and gear springs (RH and LH side).

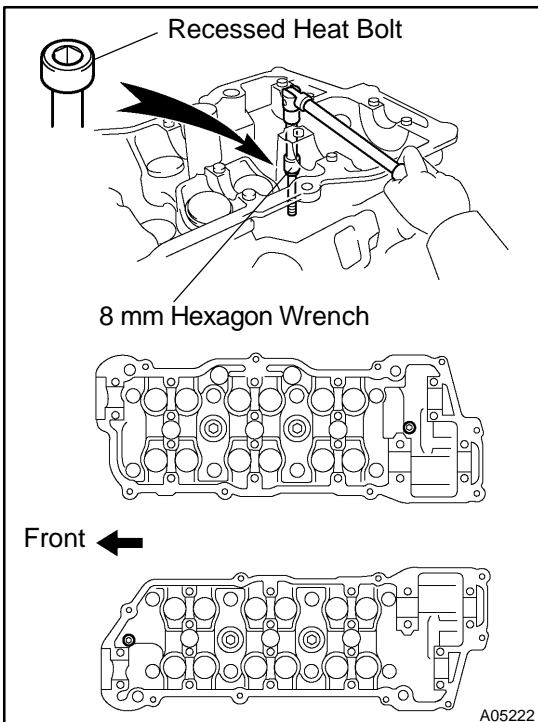

### 32. REMOVE CYLINDER HEADS

- (a) Using an 8 mm hexagon wrench, remove the cylinder head (recessed head) bolt on each cylinder head, then repeat for the other side, as shown.

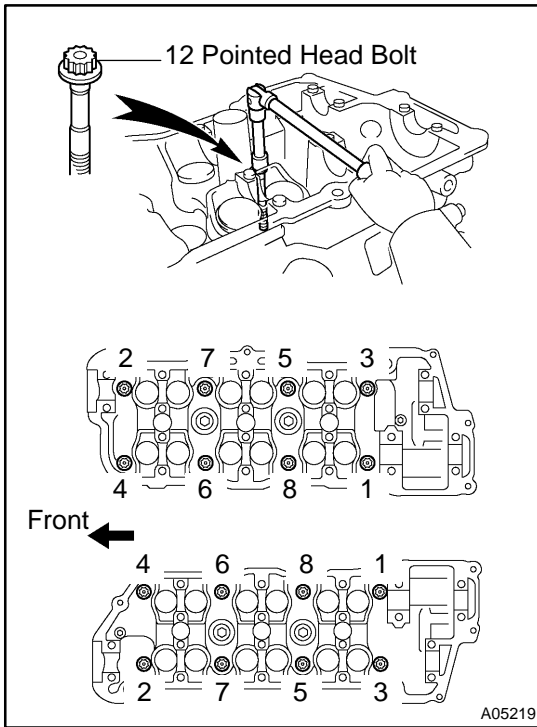

- (b) Uniformly loosen and remove the 8 cylinder head (12 pointed head) bolts on each cylinder head in several passes and in the sequence shown, then repeat for the other side, as shown. Remove the 16 cylinder head bolts and plate washers.

**NOTICE:**

Head warpage or cracking could result from removing bolts in an incorrect order.

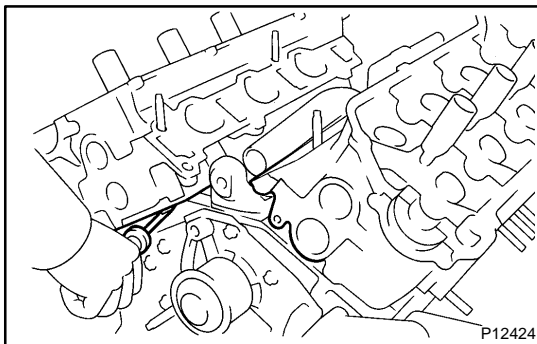

- (c) Lift the cylinder head from the dowels on the cylinder block and place the 2 cylinder heads on wooden blocks on a bench.

**HINT:**

If the cylinder head is difficult to lift off, pry between the cylinder head and cylinder block with a screwdriver.

**NOTICE:**

Be careful not to damage the contact surfaces of the cylinder head and cylinder block.

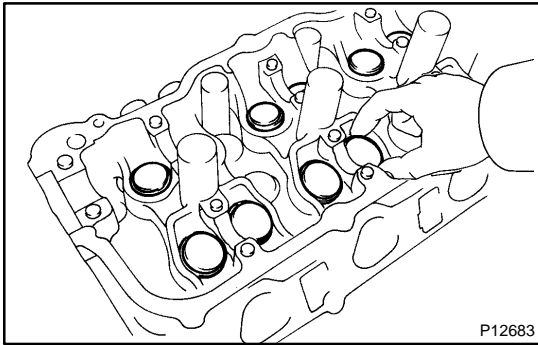

## DISASSEMBLY

### 1. REMOVE VALVE LIFTERS AND SHIMS

HINT:

Arrange the valve lifters and shims in the correct order.

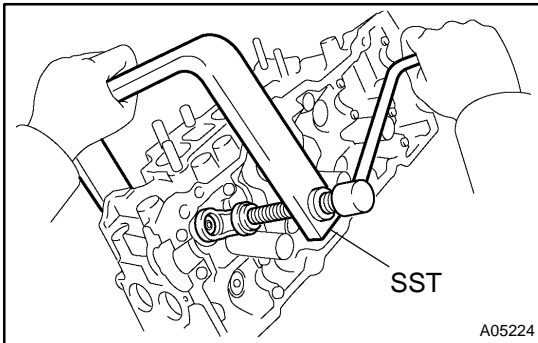

### 2. REMOVE VALVES

- (a) Using SST, compress the valve spring and remove the 2 keepers.

SST 09202-70020 (09202-00010)

- (b) Remove the spring retainer, valve spring and valve.

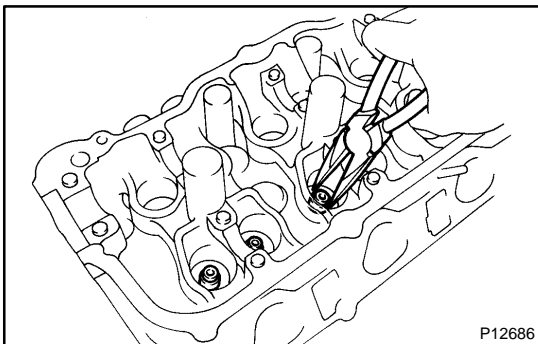

- (c) Using needle-nose pliers, remove the oil seal.

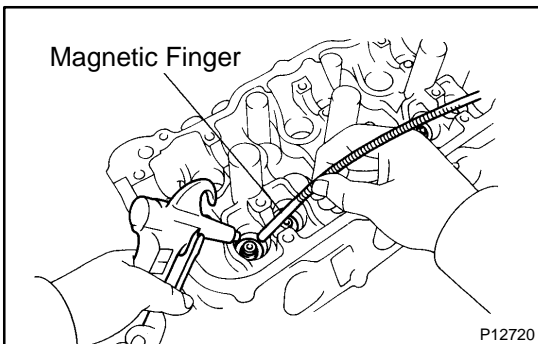

- (d) Using compressed air and a magnetic finger, remove the spring seat by blowing air.

HINT:

Arrange the valves, valve springs, spring seats and spring retainers in the correct order.

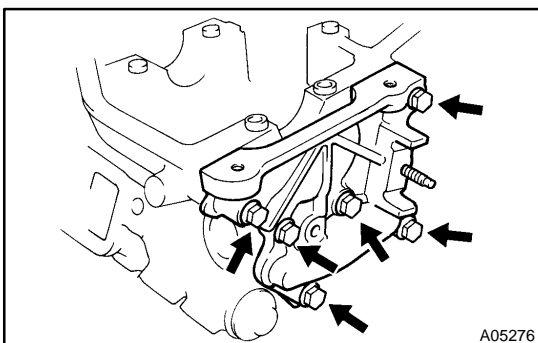

### 3. REMOVE CYLINDER HEAD REAR COVER

Remove the 6 bolts, rear cover and gasket.

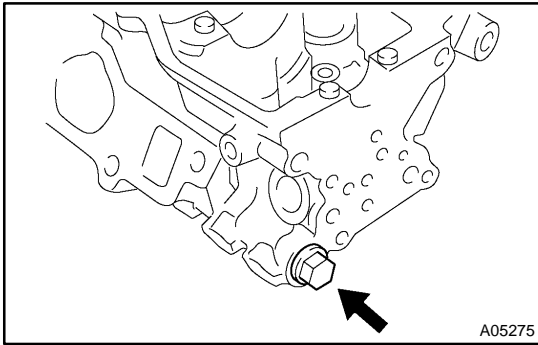

#### 4. REMOVE OIL CONTROL VALVE FILTER

Remove the plug, gasket and valve filter.

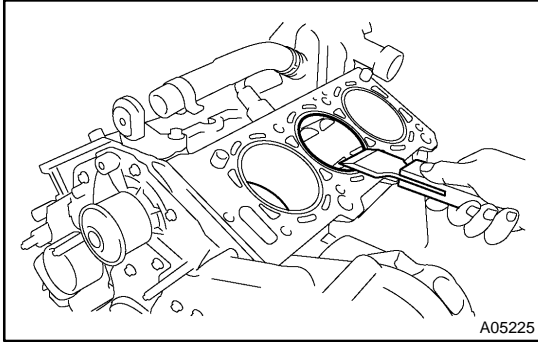

A05225

## INSPECTION

### 1. CLEAN TOP SURFACES OF PISTONS AND CYLINDER BLOCK

- (a) Turn the crankshaft, and bring each piston to top dead center (TDC). Using a gasket scraper, remove all the carbon from the piston top surface.

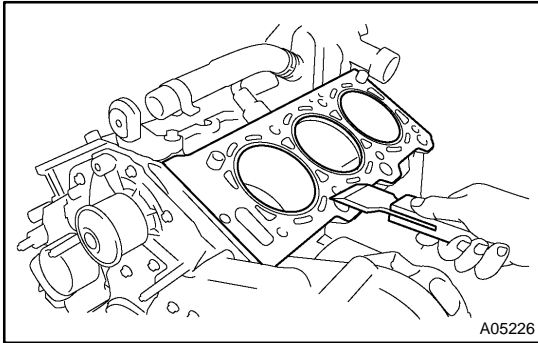

A05226

- (b) Using a gasket scraper, remove all the gasket material from the cylinder block surface.  
 (c) Using compressed air, blow carbon and oil from the bolt holes.

#### CAUTION:

**Protect your eyes when using high pressure compressed air.**

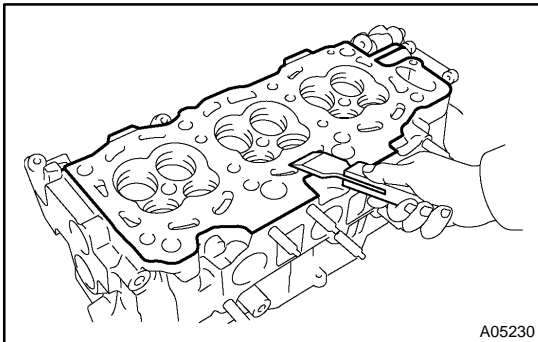

A05230

### 2. REMOVE GASKET MATERIAL

Using a gasket scraper, remove all the gasket material from the cylinder block contact surface.

#### NOTICE:

**Be careful not to scratch the cylinder block contact surface.**

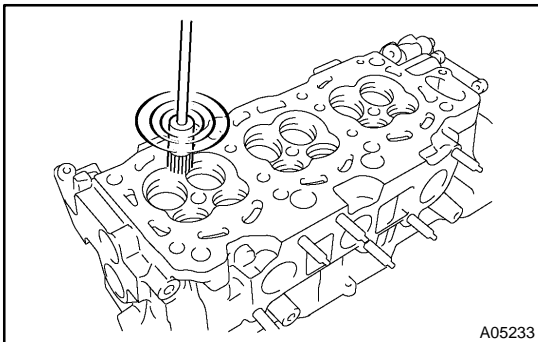

A05233

### 3. CLEAN COMBUSTION CHAMBERS

Using a wire brush, remove all the carbon from the combustion chambers.

#### NOTICE:

**Be careful not to scratch the cylinder block contact surface.**

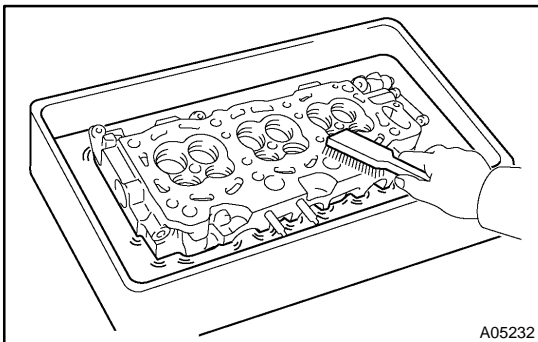

A05232

### 4. CLEAN CYLINDER HEADS

Using a soft brush and solvent, thoroughly clean the cylinder head.

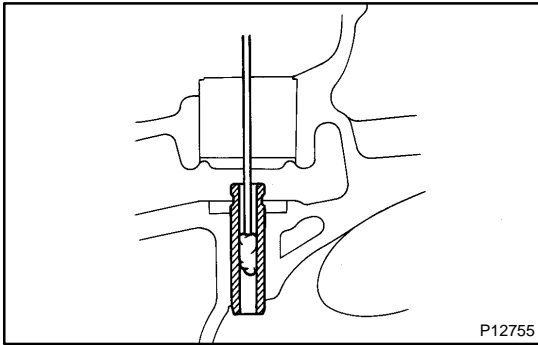

### 5. CLEAN VALVE GUIDE BUSHINGS

Using a valve guide bushing brush and solvent, clean all the guide bushings.

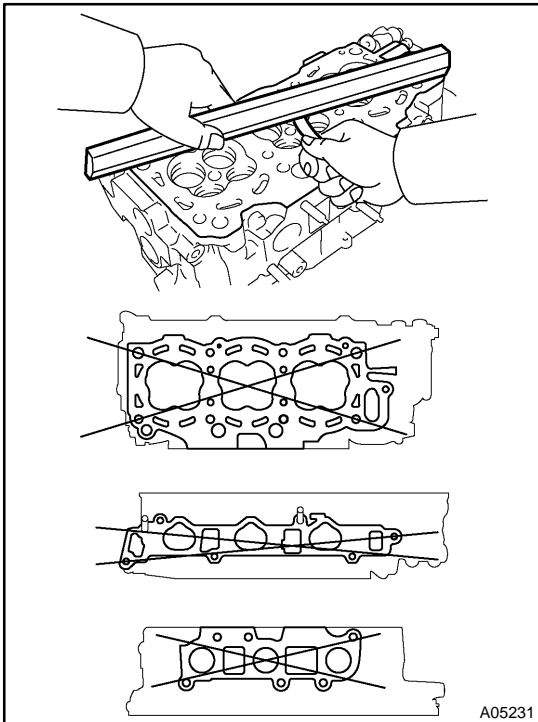

### 6. INSPECT FOR FLATNESS

Using a precision straight edge and feeler gauge, measure the surfaces contacting the cylinder block and the manifolds for warpage.

**Maximum warpage: 0.10 mm (0.0039 in.)**

If warpage is greater than maximum, replace the cylinder head.

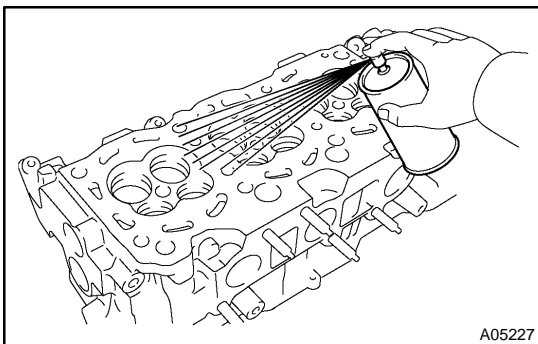

### 7. INSPECT FOR CRACKS

Using a dye penetrant, check the combustion chamber, intake ports, exhaust ports and cylinder block surface for cracks.

If cracked, replace the cylinder head.

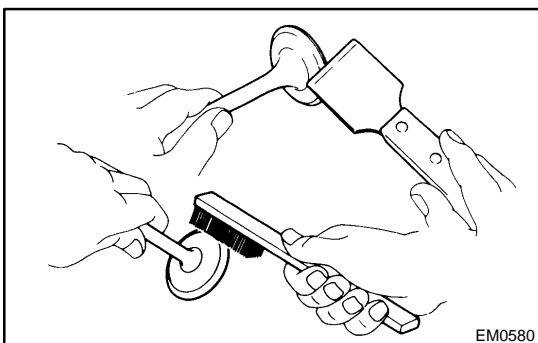

### 8. CLEAN VALVES

- (a) Using a gasket scraper, chip off any carbon from the valve head.
- (b) Using a wire brush, thoroughly clean the valve.

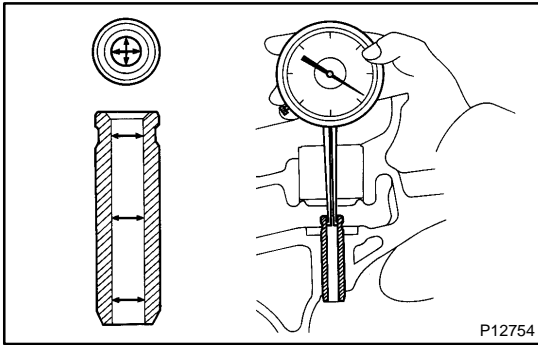

- 9. INSPECT VALVE STEMS AND GUIDE BUSHINGS**  
 (a) Using a caliper gauge, measure the inside diameter of the guide bushing.

**Bushing inside diameter:**  
 5.510 – 5.530 mm (0.2169 – 0.2177 in.)

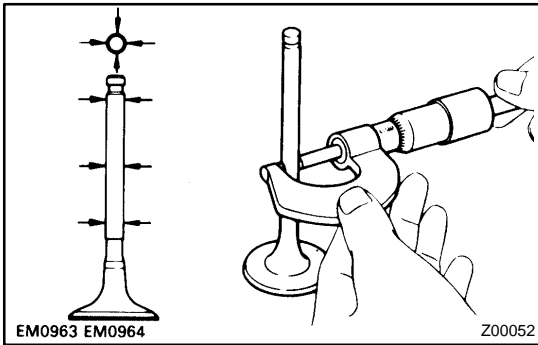

- (b) Using a micrometer, measure the diameter of the valve stem.

**Valve stem diameter:**

Intake	5.470 – 5.485 mm (0.2154 – 0.2159 in.)
Exhaust	5.465 – 5.480 mm (0.2152 – 0.2157 in.)

- (c) Subtract the valve stem diameter measurement from the guide bushing inside diameter measurement.

**Standard oil clearance:**

Intake	0.025 – 0.060 mm (0.0010 – 0.0024 in.)
Exhaust	0.030 – 0.065 mm (0.0012 – 0.0026 in.)

**Maximum oil clearance:**

Intake	0.08 mm (0.0031 in.)
Exhaust	0.10 mm (0.0039 in.)

If the clearance is greater than maximum, replace the valve and guide bushing.

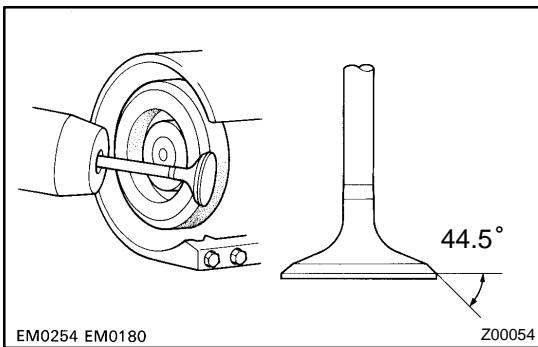

**10. INSPECT AND GRIND VALVES**

- (a) Grind the valve enough to remove pits and carbon.  
 (b) Check that the valve is ground to the correct valve face angle.

**Valve face angle: 44.5°**

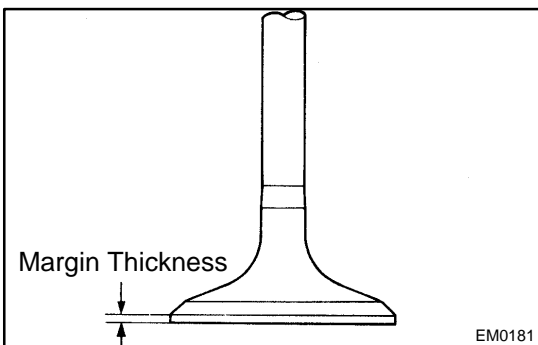

- (c) Check the valve head margin thickness.

**Standard margin thickness: 1.0 mm (0.039 in.)**  
**Minimum margin thickness: 0.5 mm (0.020 in.)**

If the margin thickness is less than minimum, replace the valve.

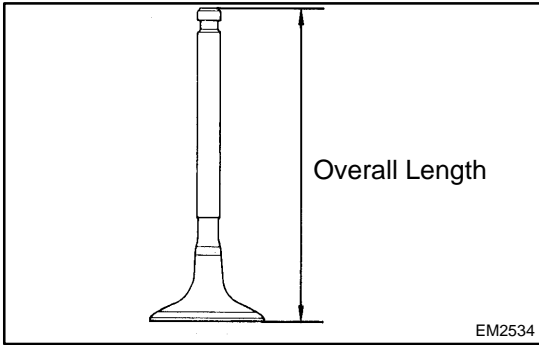

(d) Check the valve overall length.

**Standard overall length:**

Intake	95.45 mm (3.5779 in.)
Exhaust	95.40 mm (3.7559 in.)

**Minimum overall length:**

Intake	94.95 mm (3.7382 in.)
Exhaust	94.90 mm (3.7362 in.)

If the overall length is less than minimum, replace the valve.

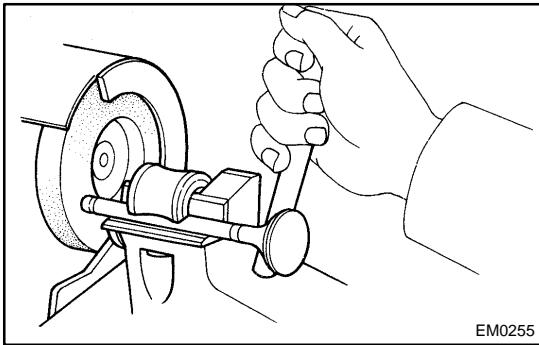

(e) Check the surface of the valve stem tip for wear.

If the valve stem tip is worn, resurface the tip with a grinder or replace the valve.

**NOTICE:**

**Do not grind off more than minimum.**

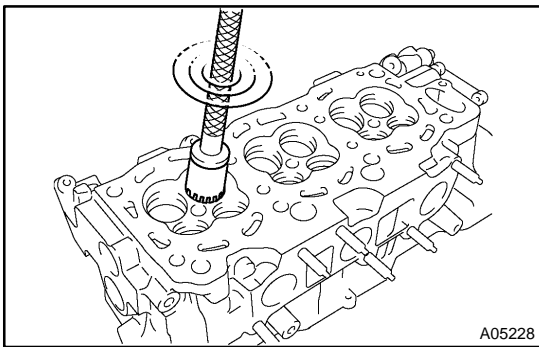

**11. INSPECT AND CLEAN VALVE SEATS**

(a) Using a 45° carbide cutter, resurface the valve seats. Remove only enough metal to clean the seats.

(b) Check the valve seating position.

Apply a light coat of prussian blue (or white lead) to the valve face. Lightly press the valve against the seat. Do not rotate valve.

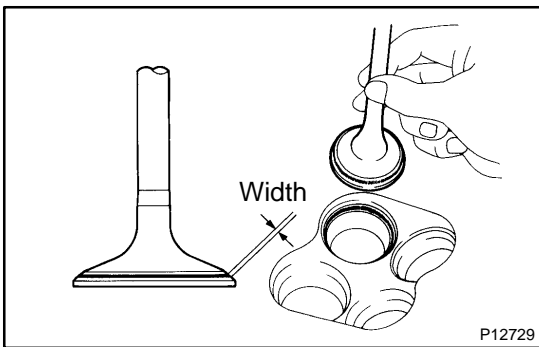

(c) Check the valve face and seat for the following:

- If blue appears 360° around the face, the valve is concentric. If not, replace the valve.
- If blue appears 360° around the valve seat, the guide and face are concentric. If not, resurface the seat.
- Check that the seat contact is in the middle of the valve face with the following width:

**1.0 – 1.4 mm (0.039 – 0.055 in.)**

If not, correct the valve seats as follows:

- (1) If the seating is too high on the valve face, use 30° and 45° cutters to correct the seat.

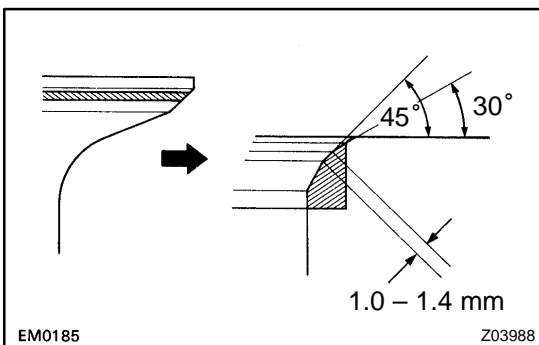

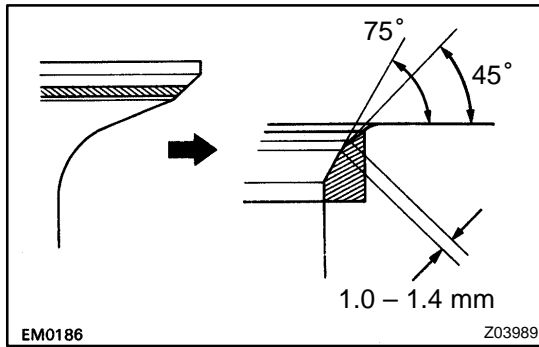

- (2) If the seating is too low on the valve face, use 75° and 45° cutters to correct the seat.

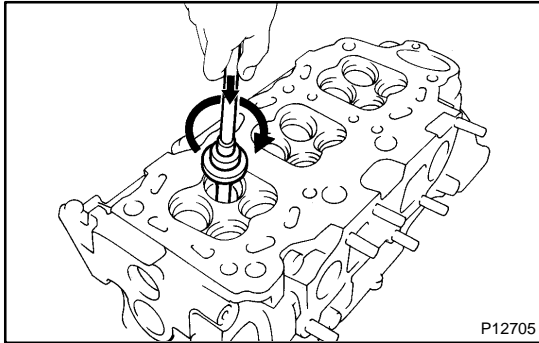

- (d) Hand-lap the valve and valve seat with an abrasive compound.  
 (e) After hand-lapping, clean the valve and valve seat.

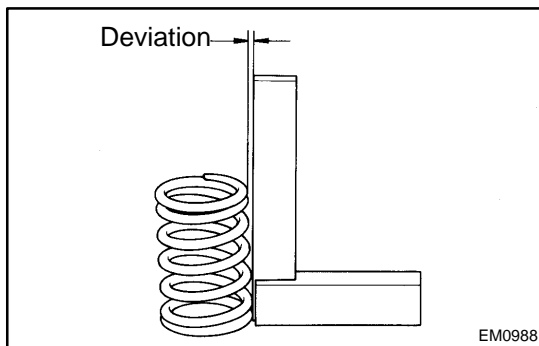

## 12. INSPECT VALVE SPRINGS

- (a) Using a steel square, measure the deviation of the valve spring.

**Maximum deviation: 2.0 mm (0.079 in.)**

If the deviation is greater than maximum, replace the valve spring.

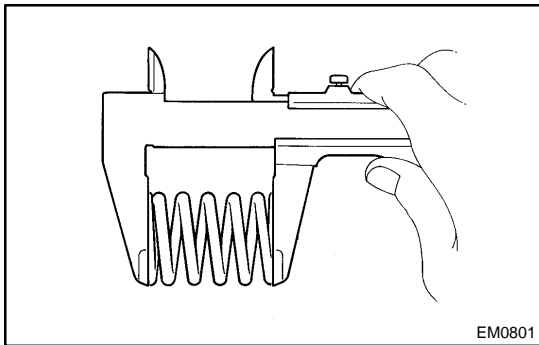

- (b) Using vernier calipers, measure the free length of the valve spring.

**Free length: 45.50 mm (1.7913 in.)**

If the free length is not as specified, replace the valve spring.

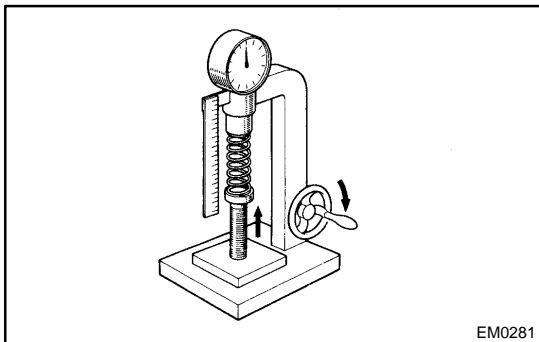

- (c) Using a spring tester, measure the tension of the valve spring at the specified installed length.

**Installed tension:**

**186 – 206 N (19.0 – 21.0 kgf, 41.9 – 46.3 lbf)**

**at 33.8 mm (1.331 in.)**

If the installed tension is not as specified, replace the valve spring.

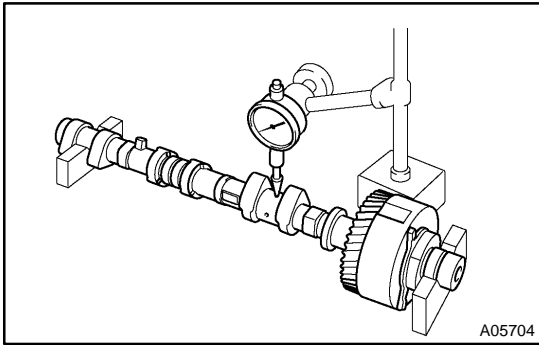

**13. INSPECT CAMSHAFT FOR RUNOUT**

- (a) Place the camshaft on V-blocks.
- (b) Using a dial indicator, measure the circle runout at the center journal.

**Maximum circle runout: 0.06 mm (0.0024 in.)**

If the circle runout is greater than maximum, replace the camshaft.

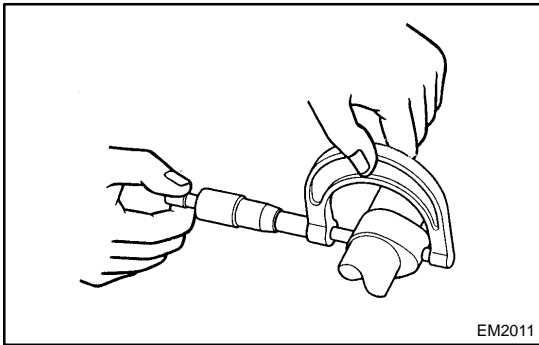

**14. INSPECT CAM LOBES**

Using a micrometer, measure the cam lobe height.

**Standard cam lobe height:**

Intake	42.932 – 43.032 mm (1.6902 – 1.6942 in.)
Exhaust	42.764 – 42.864 mm (1.6836 – 1.6876 in.)

**Minimum cam lobe height:**

Intake	42.78 mm (1.6842 in.)
Exhaust	42.61 mm (1.6776 in.)

If the cam lobe height is less than minimum, replace the camshaft.

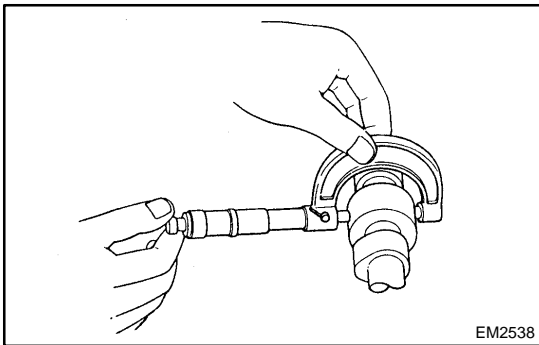

**15. INSPECT CAMSHAFT JOURNALS**

Using a micrometer, measure the journal diameter.

**Journal diameter:**

**26.959 – 26.975 mm (1.0613 – 1.0620 in.)**

If the journal diameter is not as specified, check the oil clearance.

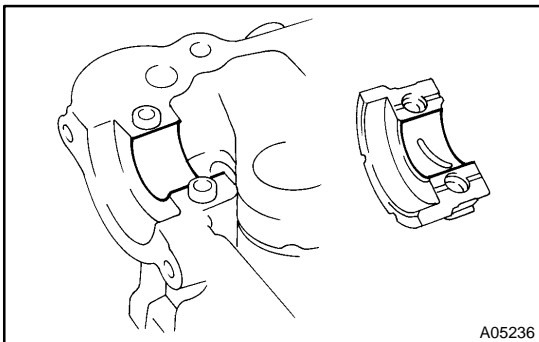

**16. INSPECT CAMSHAFT BEARINGS**

Check that bearings for flaking and scoring.

If the bearings are damaged, replace the bearing caps and cylinder head as a set.

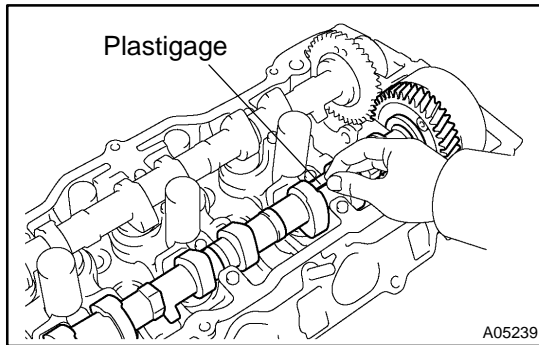

- 17. INSPECT CAMSHAFT JOURNAL OIL CLEARANCE**
- Clean the bearing caps and camshaft journals.
  - Place the camshafts on the cylinder head.
  - Lay a strip of Plastigage across each of the camshaft journal.

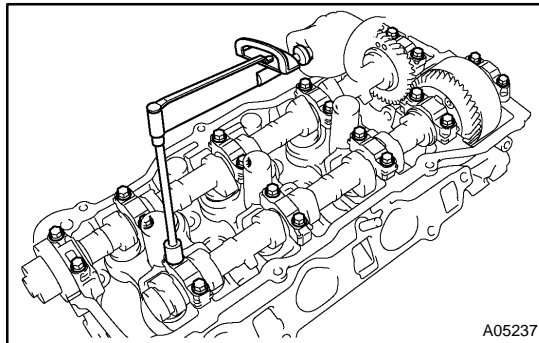

- Install the bearing caps. (See page [EM-59](#))  
**Torque: 16 N·m (160 kgf·cm, 12 ft·lbf)**

**NOTICE:****Do not turn the camshaft.**

- Remove the bearing caps.

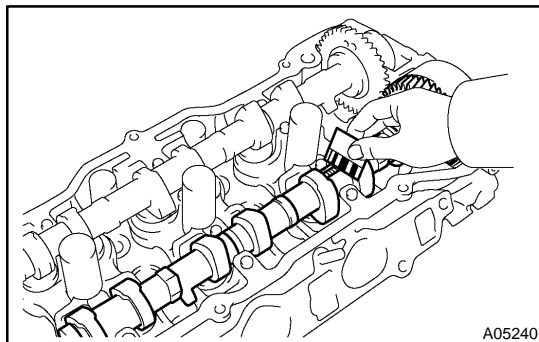

- Measure the Plastigage at its widest point.

**Standard oil clearance:**

Intake	0.035 – 0.072 mm (0.0014 – 0.0028 in.)
Exhaust	0.025 – 0.062 mm (0.0010 – 0.0024 in.)

**Maximum oil clearance:**

Intake	0.10 mm (0.0039 in.)
Exhaust	0.09 mm (0.0035 in.)

If the oil clearance is greater than maximum, replace the camshaft. If necessary, replace the bearing caps and cylinder head as a set.

- Completely remove the Plastigage.
- Remove the camshafts.

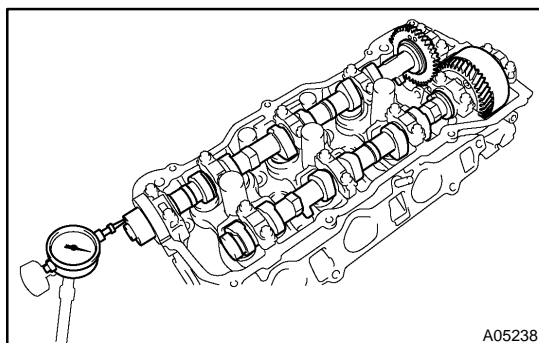
**18. INSPECT CAMSHAFT THRUST CLEARANCE**

- Install the camshafts. (See page [EM-59](#))
- Using a dial indicator, measure the thrust clearance while moving the camshaft back and forth.

**Standard thrust clearance:****0.040 – 0.090 mm (0.0016 – 0.0035 in.)****Maximum thrust clearance: 0.12 mm (0.0047 in.)**

If the thrust clearance is greater than maximum, replace the camshaft. If necessary, replace the bearing caps and cylinder head as a set.

- (c) Remove the camshafts.

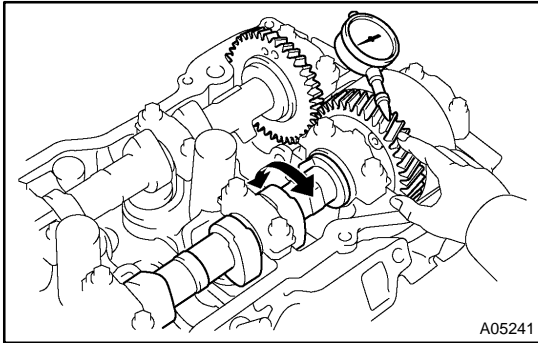

### 19. INSPECT CAMSHAFT GEAR BACKLASH

- (a) Install the camshafts without installing the exhaust cam sub-gear. (See page EM-59)  
 (b) Using a dial indicator, measure the backlash.

**Standard backlash:**

**0.020 – 0.200 mm (0.0008 – 0.0079 in.)**

**Maximum backlash: 0.30 mm (0.0188 in.)**

If the backlash is greater than maximum, replace the camshafts.

- (c) Remove the camshafts.

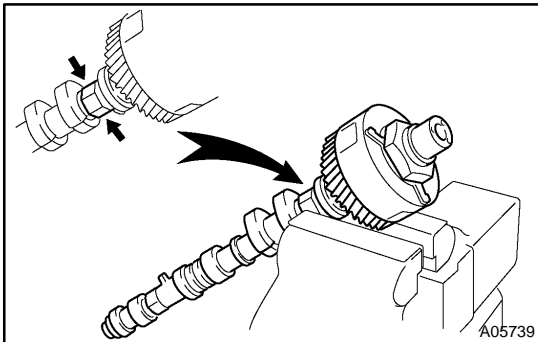

### 20. INSPECT CAMSHAFT TIMING GEAR (VVT-i)

- (a) Mount the hexagon wrench head portion of the camshaft in a vise.

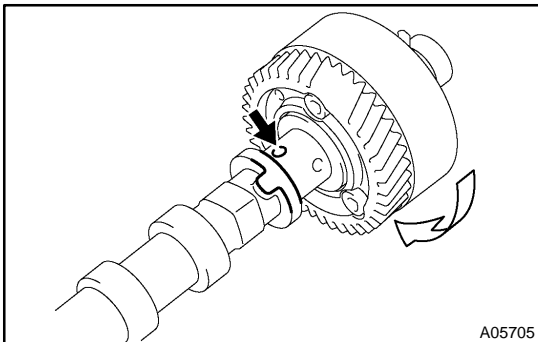

- (b) Check that VVT-i will not turn.  
 (c) Cover the port except the port on the advance angle side (nearest to the convex portion) shown in the illustration with the vinyl tape.  
 (d) Using the air gun, apply about 100 kPa (1 kgf/cm<sup>3</sup>, 14 psi) of air pressure to the port on the advance side shown in the illustration.

#### NOTICE:

**When the oil is splashed, wipe it off with a shop lug and the likes.**

#### HINT:

Perform this in order to release the lock pin for the maximum delay angle locking.

**Standard: Must turn**

#### HINT:

Depending on the air pressure, VVT-i will turn to the advance angle side without applying force by hand. Also, under the condition that the pressure can be hardly applied because of the air leakage from the port, there may be the case that the lock pin could be hardly released.

- (e) Under the condition of (d), turn VVT-i to the advance angle side (the white arrow marked direction in the illustration) with your hand.
- (f) Except the position where the lock pin meets at the maximum delay angle, let VVT-i turn back and forth and check the movable range and that there is no disturbance.  
**Standard: Movable smoothly in the range about 30°**
- (g) Turn VVT-i with your hand and lock it at the maximum delay angle position.

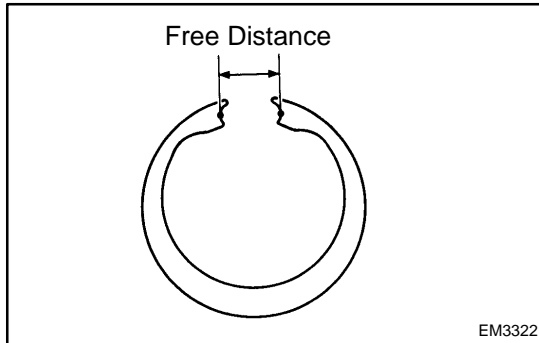

EM3322

## 21. INSPECT CAMSHAFT GEAR SPRING

Using vernier calipers, measure the free distance between the spring ends.

**Free distance: 18.2 – 18.8 mm (0.712 – 0.740 in.)**

If the free distance is not as specified, replace the gear spring.

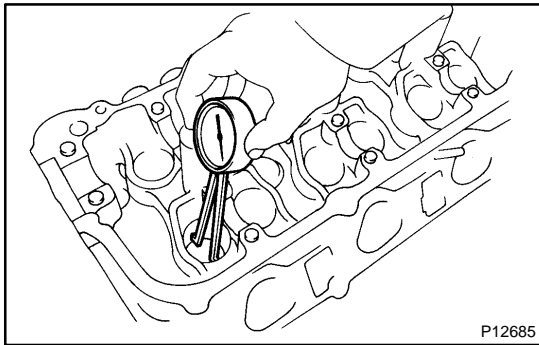

P12685

## 22. INSPECT VALVE LIFTERS AND LIFTER BORES

- (a) Using a caliper gauge, measure the lifter bore diameter of the cylinder head.

**Lifter bore diameter:**

**31.000 – 31.018 mm (1.2205 – 1.2212 in.)**

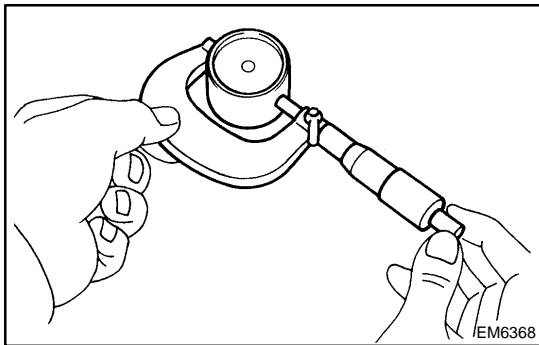

EM6368

- (b) Using a micrometer, measure the lifter diameter.

**Lifter diameter:**

**30.966 – 30.976 mm (1.2191 – 1.2195 in.)**

- (c) Subtract the lifter diameter measurement from the lifter bore diameter measurement.

**Standard oil clearance:**

**0.024 – 0.050 mm (0.0009 – 0.0020 in.)**

**Maximum oil clearance: 0.07 mm (0.0028 in.)**

If the oil clearance is greater than maximum, replace the lifter. If necessary, replace the cylinder head.

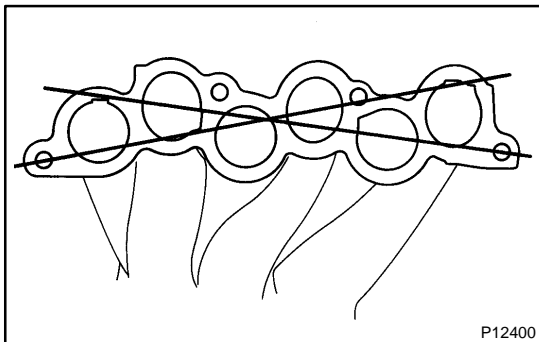

P12400

## 23. INSPECT AIR INTAKE CHAMBER

Using a precision straight edge and feeler gauge, measure the surface contacting the intake manifold for warpage.

**Maximum warpage: 0.10 mm (0.0039 in.)**

If warpage is greater than maximum, replace the chamber.

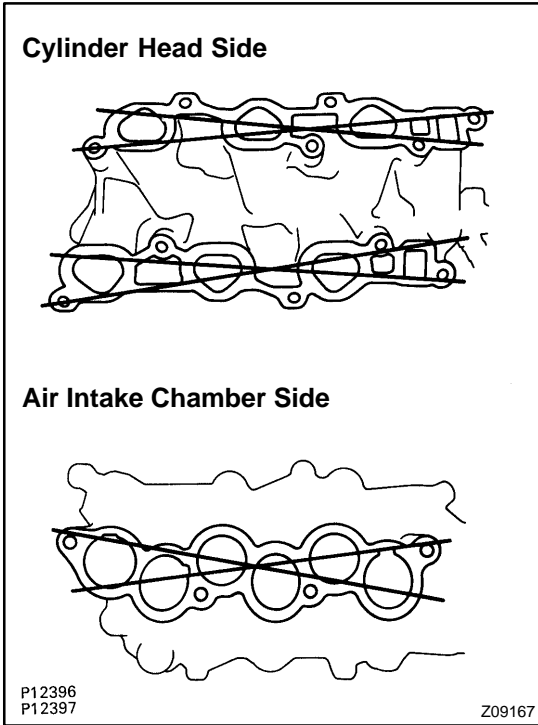

**24. INSPECT INTAKE MANIFOLD**

Using a precision straight edge and feeler gauge, measure the surface contacting the cylinder head and air intake chamber for warpage.

**Maximum warpage:**

Air intake chamber side	0.15 mm (0.0059 in.)
Cylinder head side	0.08 mm (0.0031 in.)

If warpage is greater than maximum, replace the manifold.

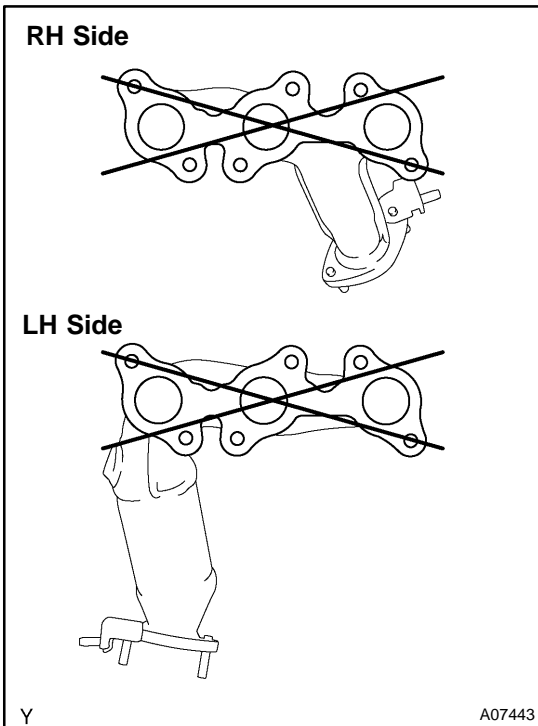

**25. INSPECT EXHAUST MANIFOLDS**

Using a precision straight edge and feeler gauge, measure the surface contacting the cylinder head for warpage.

**Maximum warpage: 0.50 mm (0.0196 in.)**

If warpage is greater than maximum, replace the manifold.

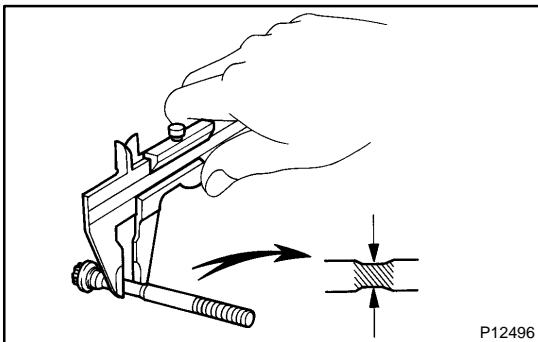

**26. INSPECT 12 POINTED HEAD CYLINDER HEAD BOLTS**

Using vernier calipers, measure the tension portion diameter of the bolt.

**Standard outside diameter:**

**8.95 – 9.05 mm (0.3524 – 0.3563 in.)**

**Minimum outside diameter: 8.75 mm (0.3445 in.)**

If the diameter is less than minimum, replace the bolt.

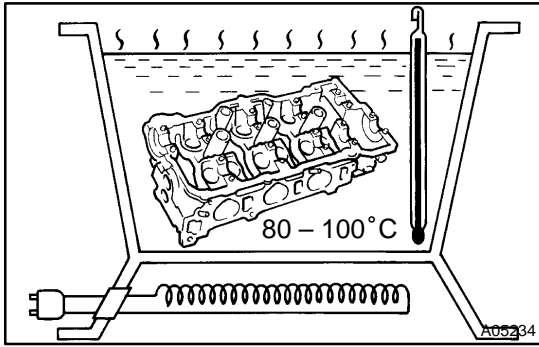

## REPLACEMENT

### 1. REPLACE VALVE GUIDE BUSHINGS

(a) Gradually heat the cylinder head to 80 – 100°C (176 – 212°F).

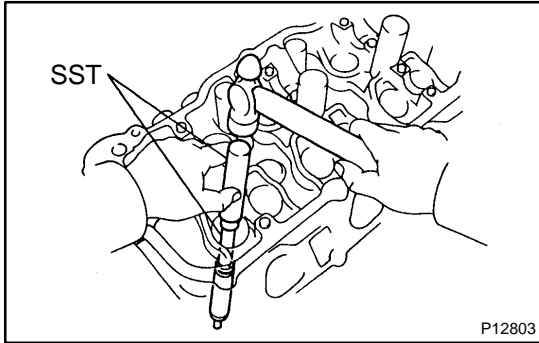

(b) Using SST and a hammer, tap out the guide bushing.  
SST 09201-01055, 09950-70010 (09951-07100)

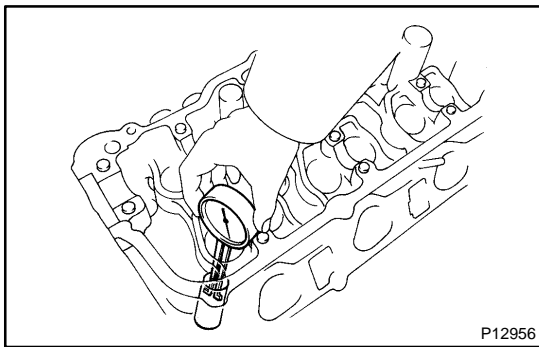

(c) Using a caliper gauge, measure the bushing bore diameter of the cylinder head.

Both intake and exhaust

Bushing bore diameter mm (in.)	Bushing size
10.295 – 10.313 (0.4053 – 0.4060)	Use STD
10.345 – 10.363 (0.4073 – 0.4080)	Use O/S 0.05

(d) Select a new guide bushing (STD or O/S 0.05).

If the bushing bore diameter of the cylinder head is greater than 10.313 mm (0.4060 in.), machine the bushing bore to the following dimension:

**10.345 – 10.363 mm (0.4073 – 0.4080 in.)**

If the bushing bore diameter of the cylinder head is greater than 10.363 mm (0.4080 in.), replace the cylinder head.

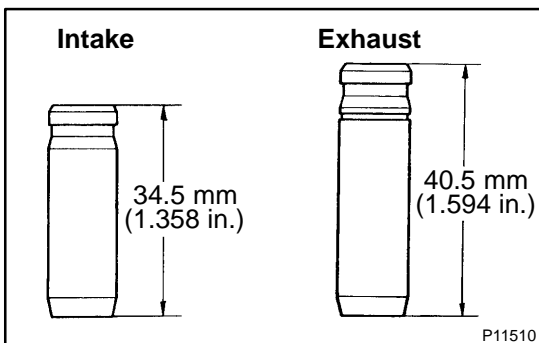

#### HINT:

Different bushings are used for the intake and exhaust.

(e) Gradually heat the cylinder head to 80 – 100°C (176 – 212°F).

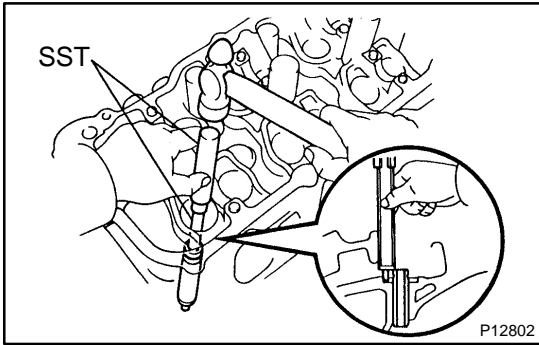

- (f) Using SST and a hammer, tap in a new guide bushing to the specified protrusion height.

SST 09201-01055, 09950-70010 (09951-07100)

**Protrusion height:**

Intake	11.1 – 11.3 mm (0.437 – 0.453 in.)
Exhaust	8.9 – 9.3 mm – (0.350 – 0.366 in.)

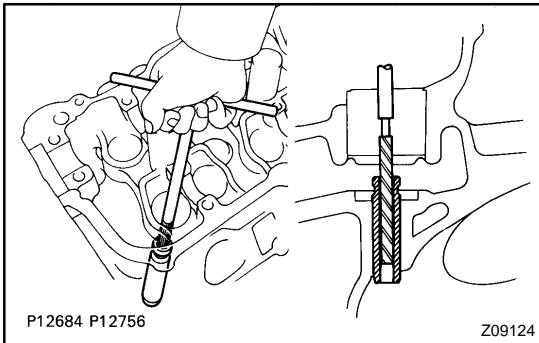

- (g) Using a sharp 5.5 mm reamer, ream the guide bushing to obtain the standard specified clearance (See page EM-42) between the guide bushing and valve stem.

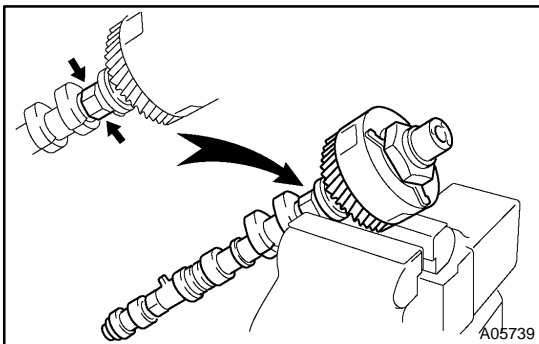

**2. REPLACE CAMSHAFT TIMING GEAR (VVT-i)**

**NOTICE:**

**Do not remove or install the camshaft timing gear (VVT-i) beside changing VVT-i or the camshaft.**

- (a) Mount the hexagon wrench head portion of the camshaft in a vise.

**NOTICE:**

**Be careful not to damage the camshaft.**

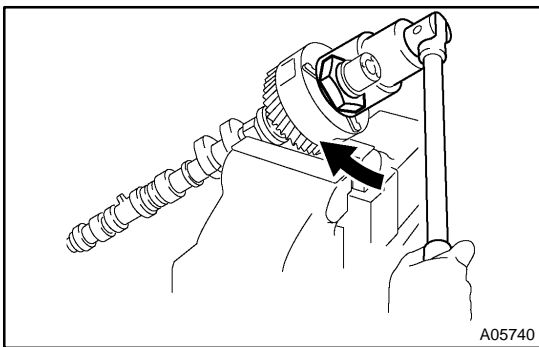

- (b) Using a 46 mm socket wrench, remove the lock nut by turning it clockwise.

**NOTICE:**

- Remove it under the condition that the lock pin is operated and lock at the maximum delay angle position.
- The lock nut have LH threads.
- Never use any tool other than the socket wrench, otherwise that may result in deforming the cam angle rotor portion.

- (c) Remove the camshaft VVT-i.

**HINT:**

In case of having difficulty to remove VVT-i, apply a slight hitting using a plastic-faced hammer and then remove it.

**NOTICE:**

**Never remove the 3 bolts on the gear.**

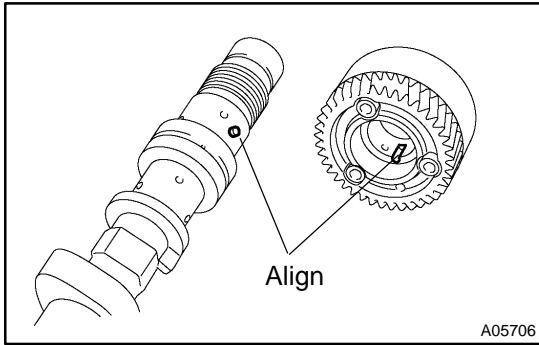

- (d) Align the knock pin and knock pin groove and install VVT-i on the camshaft.

**NOTICE:**

Install it under the condition that the lock pin is operated and lock at the maximum delay angle position.

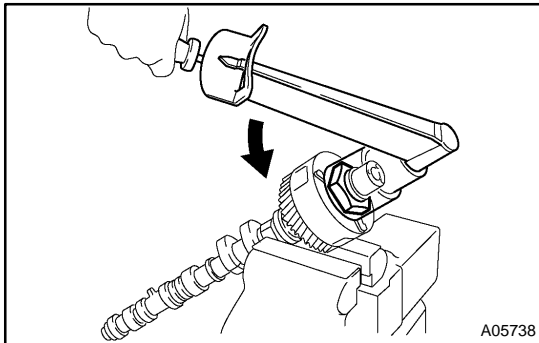

- (e) Apply the engine oil on the nut, the placing surface of VVT-i and the screw portion.

**HINT:**

Be sure to apply the oil, otherwise the prescribed torque cannot be obtained.

- (f) Using a 46 mm socket wrench, install and torque a new lock nut by turning it counterclockwise.

**Torque: 150 N·m (1,530 kgf·cm, 110 ft·lbf)**

**NOTICE:**

- **Must change the nuts to the new ones when to change VVT-i.**
- **The lock nut have LH threads.**
- **Never use any tool other than the socket wrench, otherwise that may result in deforming the cam angle rotor portion.**

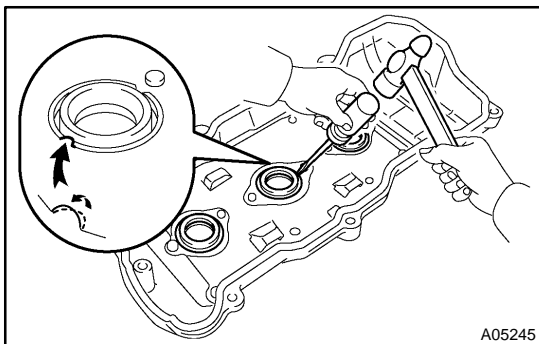
**3. REPLACE SPARK PLUG TUBE GASKETS**

- (a) Bend up the tab on the ventilation baffle plate which prevents the gasket from the slipping out.  
 (b) Using a screwdriver and hammer, tap out the gasket.

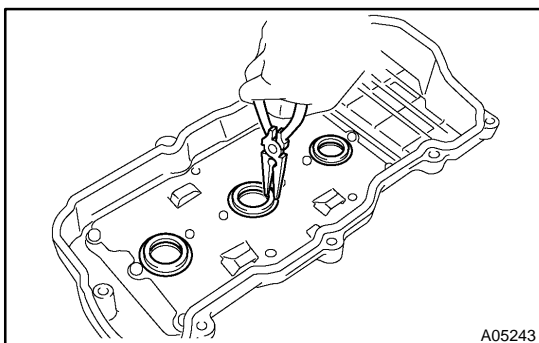

- (c) Using needle-nose pliers, pry out the gasket.

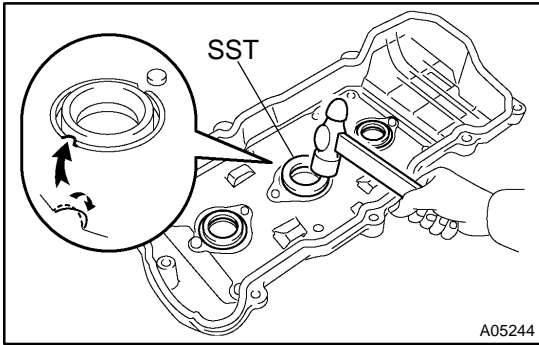

- (d) Using SST and a hammer, tap in a new gasket until its surface is flush with the upper edge of the cylinder head cover.  
SST 09608-03071
- (e) Apply a light coat of MP grease to the gasket lip.
- (f) Return the ventilation plate tab to its original position.

## REASSEMBLY

### HINT:

- Thoroughly clean all parts to be assembled.
- Before installing the parts, apply new engine oil to all sliding and rotating surfaces.
- Replace all gaskets and oil seals with new ones.

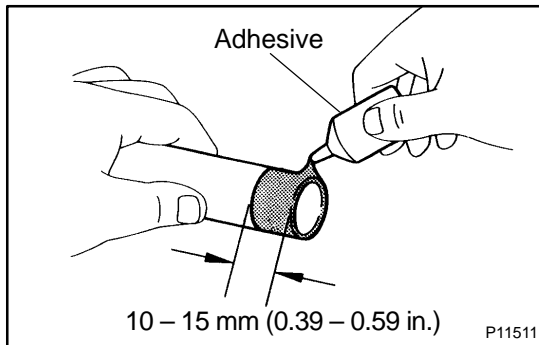

### 1. INSTALL SPARK PLUG TUBES

#### HINT:

When using a new cylinder head, spark plug tubes must be installed.

- (a) Apply adhesive to the end of the spark plug tube.  
**Adhesive: Part No. 08833-00070, THREE BOND 1324 or equivalent**

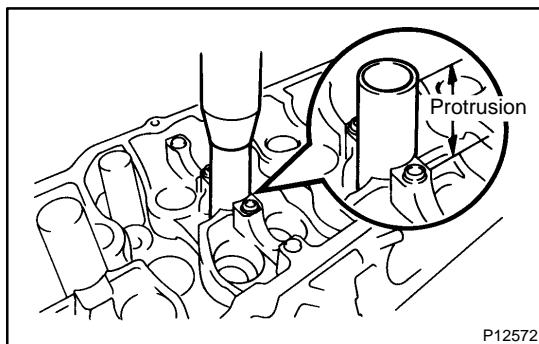

- (b) Using a press, press in a new spark plug tube until there is 42.4 – 43.4 mm (1.669 – 1.709 in.) protruding from the camshaft bearing cap installation surface of the cylinder head.

#### NOTICE:

**Avoid pressing a new spark plug tube in too far by measuring the amount of the protrusion while pressing.**

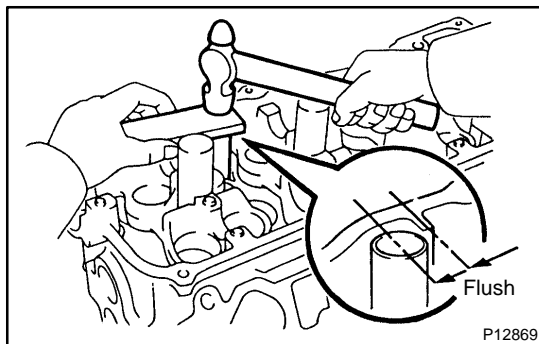

### 2. INSTALL PCV PIPES

#### HINT:

When using a new cylinder head, PCV pipe must be installed. Using a wooden block and hammer, tap in a new PCV pipe until its top side is flush with the cylinder head edge.

#### NOTICE:

**Be careful not to damage the cylinder head edge.**

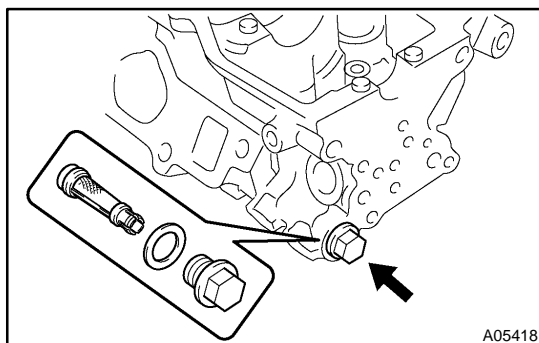

### 3. INSTALL OIL CONTROL VALVE FILTER

- (a) Assemble the valve filter and plug.  
 (b) Install the plug with new gasket.

**Torque: 45 N·m (460 kgf·cm, 33 ft·lbf)**

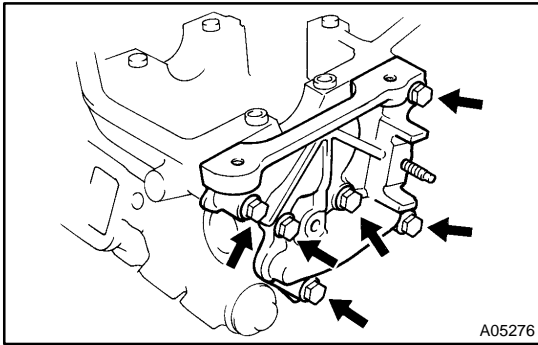

#### 4. INSTALL CYLINDER HEAD REAR COVER

Install the rear cover and gasket with the 6 bolts.

**Torque: 10 N·m (100 kgf·cm, 7.3 ft·lbf)**

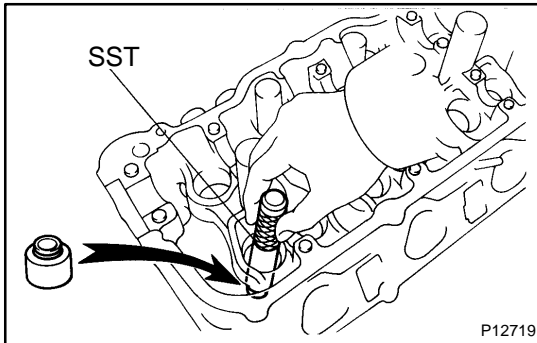

#### 5. INSTALL VALVES

(a) Using SST, push in a new oil seal.

SST 09201-41020

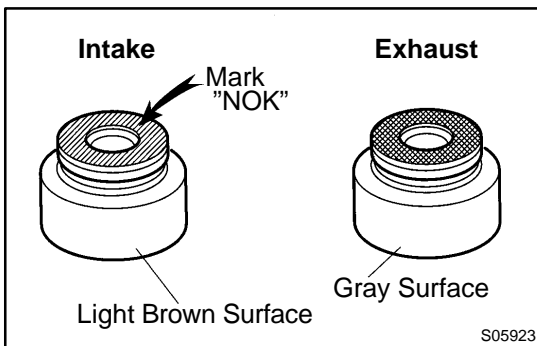

**HINT:**

The intake valve oil seal is light brown and the exhaust valve oil seal is gray.

**NOTICE:**

**Pay much attention when assembling the oil seal for intake and exhaust. Assembling the wrong one may cause a failure.**

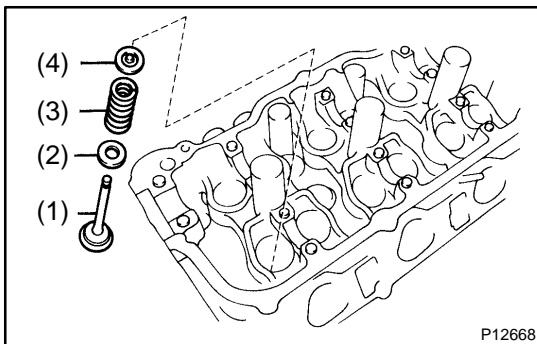

(b) Install the valve (1), spring seat (2), valve spring (3) and spring retainer (4).

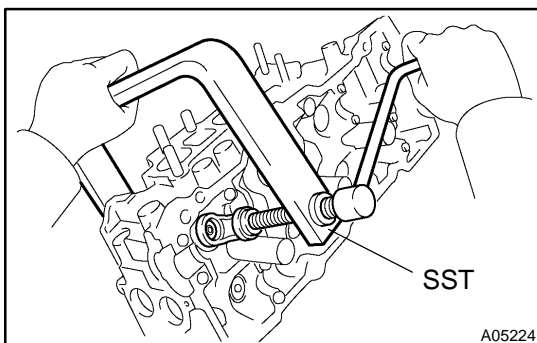

(c) Using SST, compress the valve spring and place the 2 keepers around the valve stem.

SST 09202-70020 (09202-00010)

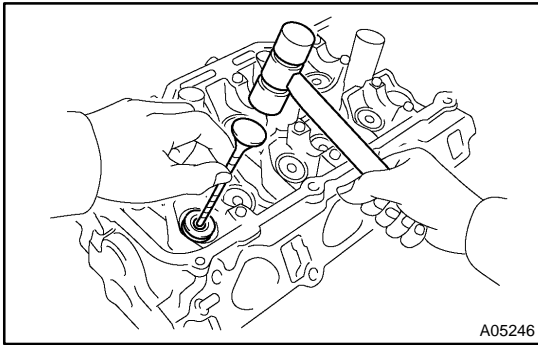

- (d) Using a plastic-faced hammer and the valve stem (not in use) tip wound with vinyl tape, lightly tap the valve stem tip to assure proper fit.

**NOTICE:**

**Be careful not to damage the valve stem tip.**

**6. INSTALL VALVE LIFTERS AND SHIMS**

- (a) Install the valve lifter and shim.  
(b) Check that the valve lifter rotates smoothly by hand.

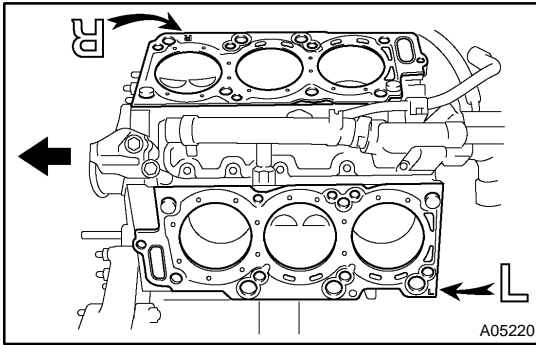

## INSTALLATION

### 1. PLACE CYLINDER HEAD ON CYLINDER BLOCK

- (a) Place 2 new cylinder head gaskets in position on the cylinder block.

#### NOTICE:

**Be careful of the installation direction.**

- (b) Place the 2 cylinder heads in position on the cylinder head gaskets.

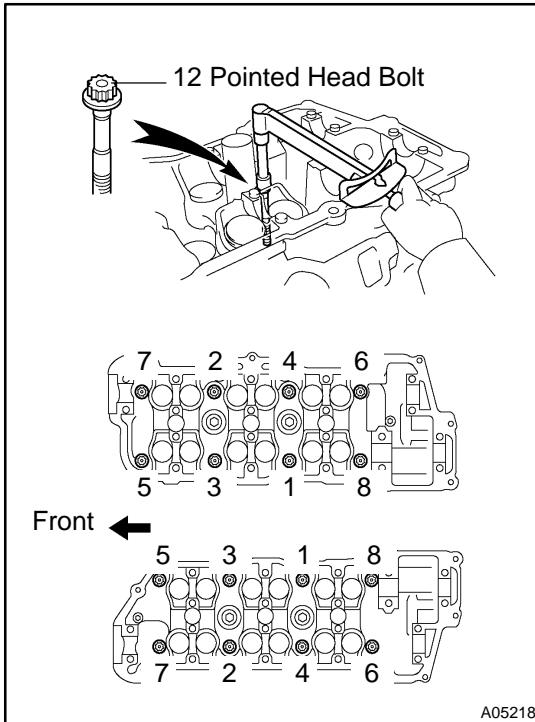

### 2. INSTALL 12 POINTED HEAD CYLINDER HEAD BOLTS

#### HINT:

- The cylinder head bolts are tightened in 2 progressive steps (steps (c) and (e)).

- If any bolt is broken or deformed, replace it.

- (a) Apply a light coat of engine oil on the threads and under the heads of the cylinder head bolts.

- (b) Install the plate washer to the cylinder head bolt.

- (c) Install and uniformly tighten the cylinder head bolts on each cylinder head in several passes and in the sequence shown, then repeat for the other side, as shown.

**Torque: 54 N·m (550 kgf·cm, 40 ft·lbf)**

If any of the cylinder head bolts does not meet the torque specification, replace the cylinder head bolt.

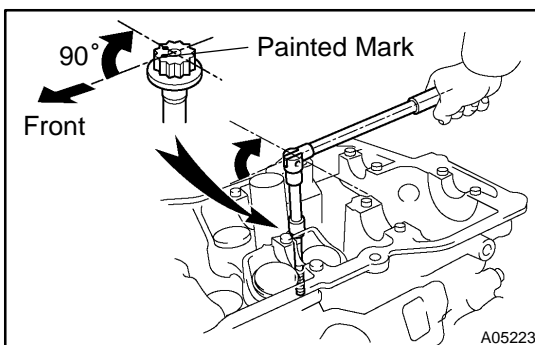

- (d) Mark the front of the cylinder head bolt head with paint.

- (e) Retighten the cylinder head bolts by 90° in the numerical order shown.

- (f) Check that the painted mark is now at a 90° angle to the front.

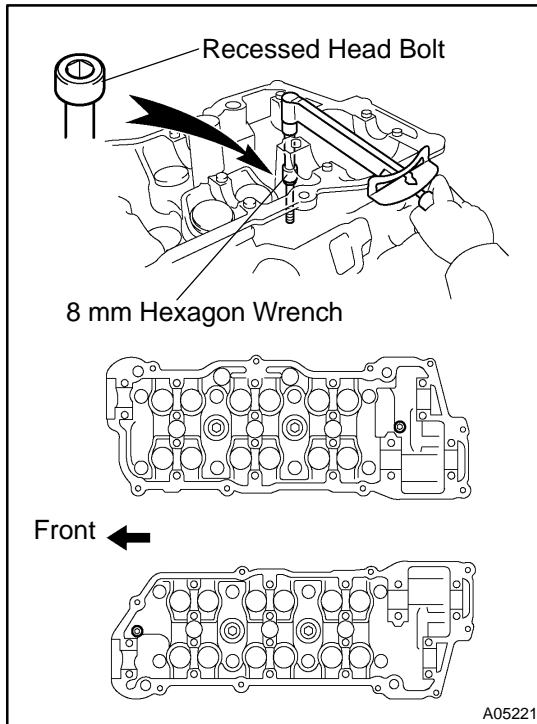

### 3. INSTALL RECESSED HEAD CYLINDER HEAD BOLTS

- Apply a light coat of engine oil on the threads and under the heads of the cylinder head bolts.
- Using an 8 mm hexagon wrench, install the cylinder head bolt on each cylinder head, then repeat for the other side, as shown.

**Torque: 18.5 N·m (185 kgf·cm, 13 ft·lbf)**

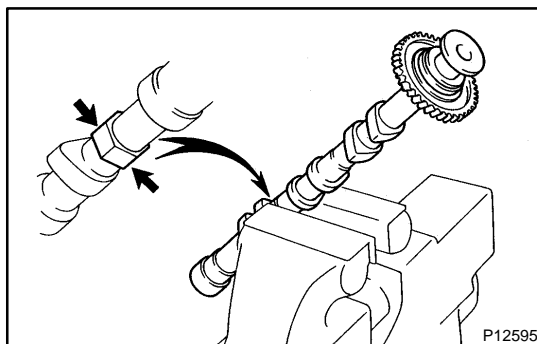

### 4. ASSEMBLE EXHAUST CAMSHAFTS

- Mount the hexagonal wrench head portion of the camshaft in a vise.

**NOTICE:**

**Be careful not to damage the camshaft.**

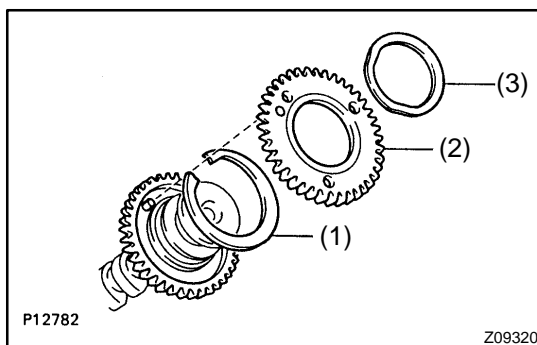

- Install the camshaft gear spring (1) and camshaft sub-gear (2).

**HINT:**

Attach the pins on the gears to the gear spring ends.

- Install the wave washer (3).

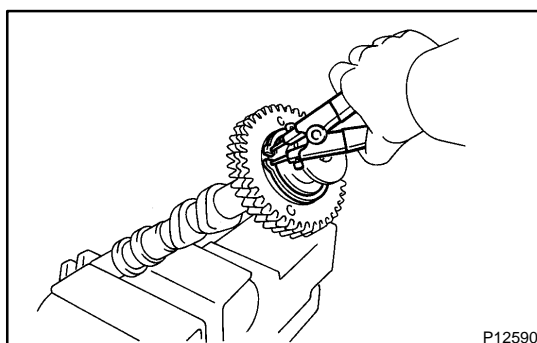

- Using snap ring pliers, install the snap ring.

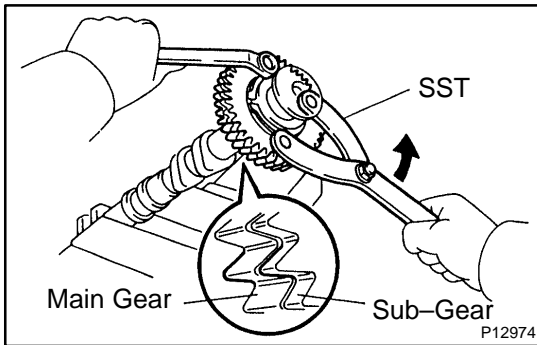

- (e) Using SST, align the holes of the camshaft main gear and sub-gear by turning camshaft sub-gear counterclockwise, and temporarily install a service bolt.  
SST 09960-10010 (09962-01000, 09963-00500)
- (f) Align the gear teeth of the main gear and sub-gear, and tighten the service bolt.

## 5. INSTALL CAMSHAFTS OF RH CYLINDER HEAD

### NOTICE:

Since the thrust clearance of the camshaft is small, the camshaft must be kept leveled while it is being installed. If the camshaft is not kept leveled, the portion of the cylinder head receiving the shaft thrust may crack or be damaged, causing the camshaft to seize or break. To avoid this, the following steps should be carried out.

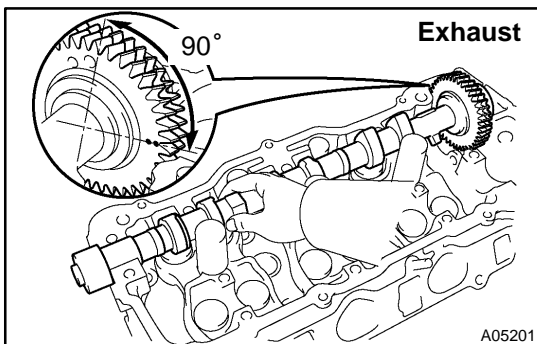

- (a) Install the exhaust camshaft.
  - (1) Apply new engine oil to the thrust portion and journal of the camshaft.
  - (2) Place the exhaust camshaft at 90° angle of timing mark (2 dot marks) on the cylinder head.
  - (3) Apply MP grease to a new oil seal lip.

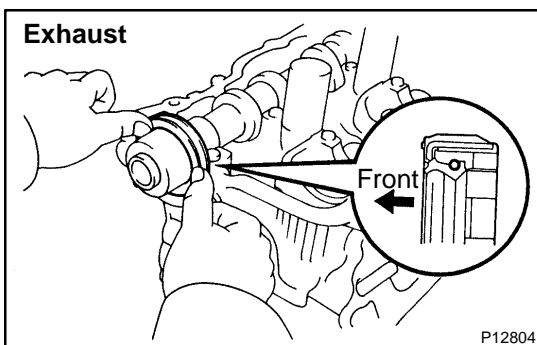

- (4) Install the oil seal to the camshaft.

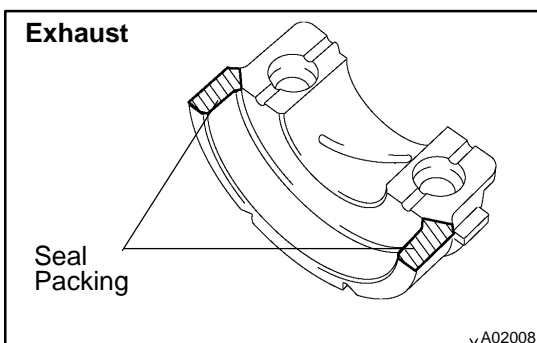

- (5) Remove any old packing (FIPG) material.
- (6) Apply seal packing to the No.1 bearing cap as shown.

**Seal packing: Part No. 08826-00080 or equivalent**

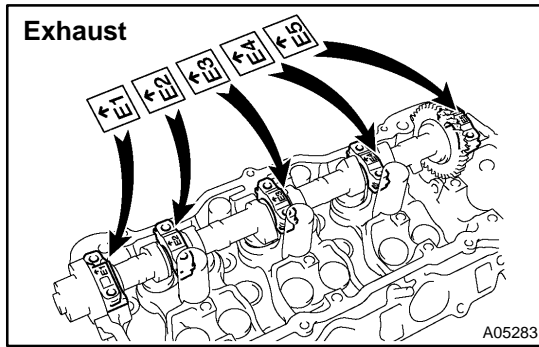

- (b) Install the 5 bearing caps in their proper locations.

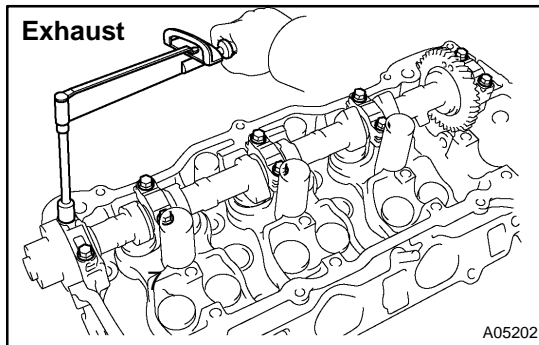

- (c) Apply a light coat of engine oil on the threads and under the heads of the bearing cap bolts.
- (d) Install and uniformly tighten the 10 bearing cap bolts in several passes and in the sequence shown.  
**Torque: 16 N·m (160 kgf·cm, 12 ft·lbf)**

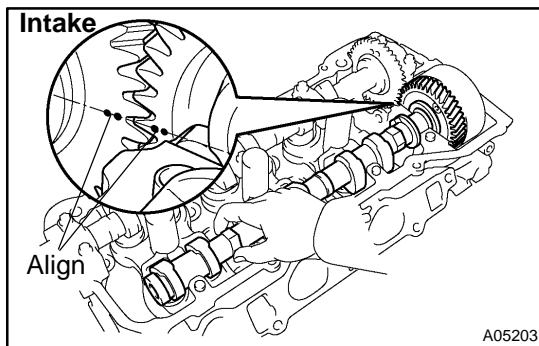

- (e) Install the Intake camshaft.
- (1) Apply new engine oil to the thrust portion and journal of the camshaft.
  - (2) Align the timing marks (2 dot marks) of the camshaft drive and driven gears.
  - (3) Place the intake camshaft on the cylinder head.

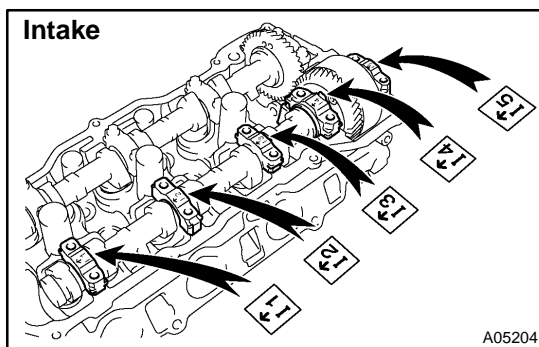

- (4) Install the 5 bearing caps in their proper locations.

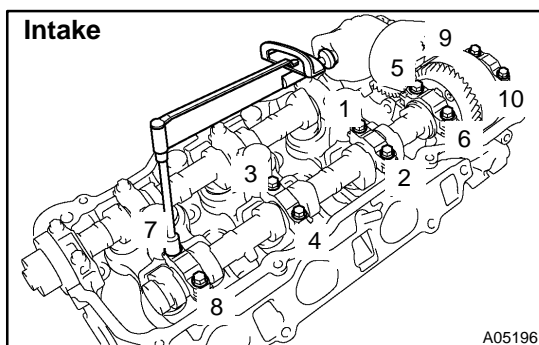

- (5) Apply a light coat of engine oil on the threads and under the heads of the bearing cap bolts.
- (6) Install and uniformly tighten the 10 bearing cap bolts in several passes and in the sequence shown.  
**Torque: 16 N·m (160 kgf·cm, 12 ft·lbf)**

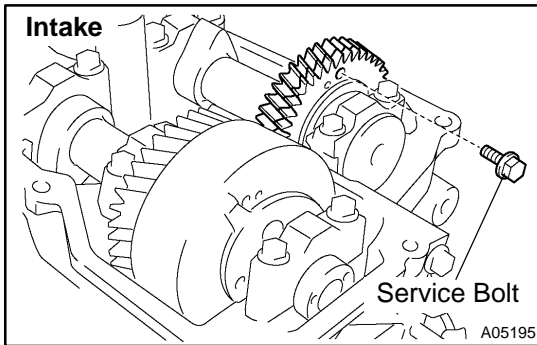

- (7) Remove the service bolt.

## 6. INSTALL CAMSHAFTS OF LH CYLINDER HEAD

### NOTICE:

Since the thrust clearance of the camshaft is small, the camshaft must be kept leveled while it is being installed. If the camshaft is not kept leveled, the portion of the cylinder head receiving the shaft thrust may crack or be damaged, causing the camshaft to seize or break. To avoid this, the following steps should be carried out.

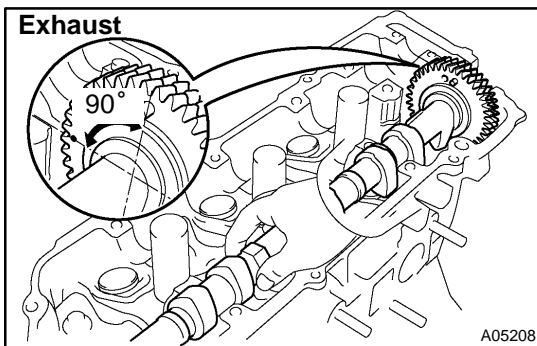

- (a) Install the exhaust camshaft.
- (1) Apply new engine oil to the thrust portion and journal of the camshaft.
  - (2) Place the exhaust camshaft at 90° angle of timing mark (1 dot mark) on the cylinder head.
  - (3) Apply MP grease to a new oil seal lip.

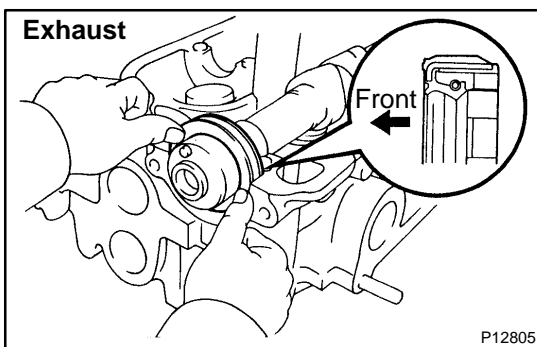

- (4) Install the oil seal to the camshaft.

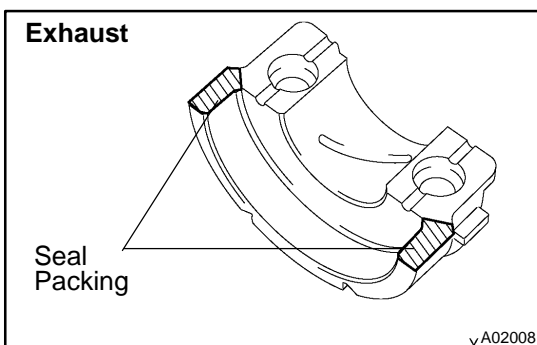

- (5) Remove any old packing (FIPG) material.
- (6) Apply seal packing to the No.1 bearing cap as shown.

**Seal packing: Part No. 08826-00080 or equivalent**

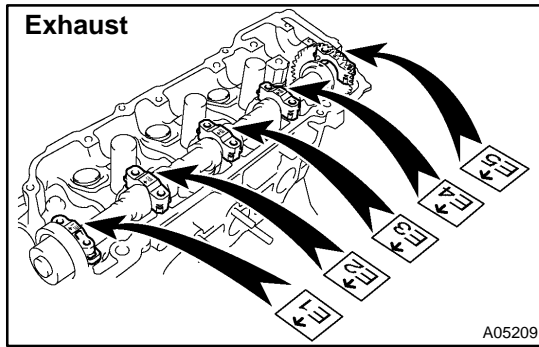

- (7) Install the 5 bearing caps in their proper locations.

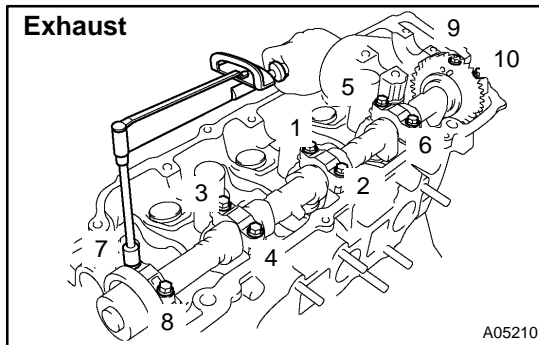

- (8) Apply a light coat of engine oil on the threads and under the heads of the bearing cap bolts.  
 (9) Install and uniformly tighten the 10 bearing cap bolts in several passes and in the sequence shown.

**Torque: 16 N·m (160 kgf-cm, 12 ft-lbf)**

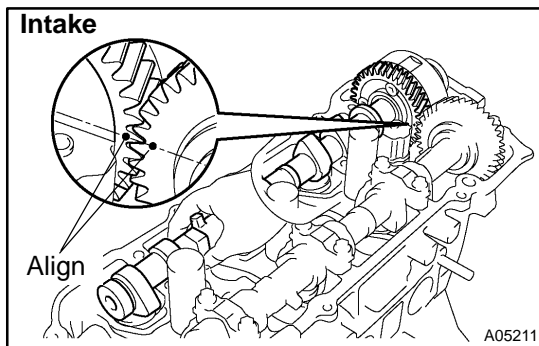

- (b) Install the intake camshaft.  
 (1) Apply new engine oil to the thrust portion and journal of the camshaft.  
 (2) Align the timing marks (1 dot mark) of the camshaft drive and driven gears.  
 (3) Place the intake camshaft on the cylinder head.

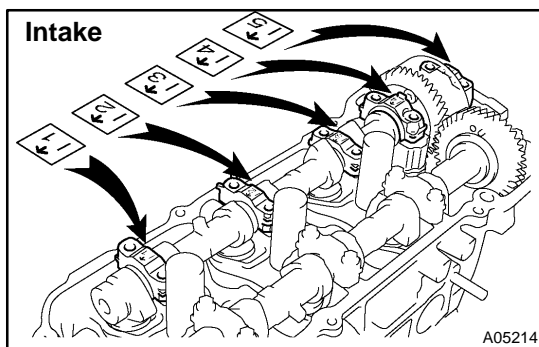

- (4) Install the 5 bearing caps in their proper locations.

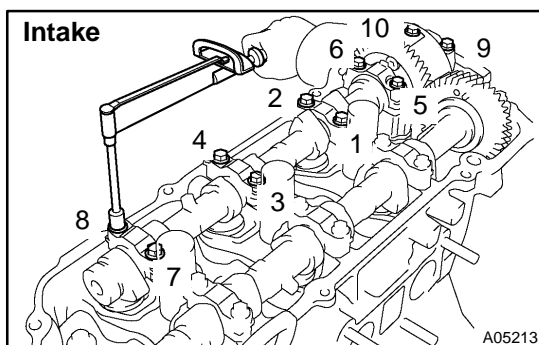

- (5) Apply a light coat of engine oil on the threads and under the heads of bearing cap bolts.  
 (6) Install and uniformly tighten the 10 bearing cap bolts in several passes and in the sequence shown.

**Torque: 16 N·m (160 kgf-cm, 12 ft-lbf)**

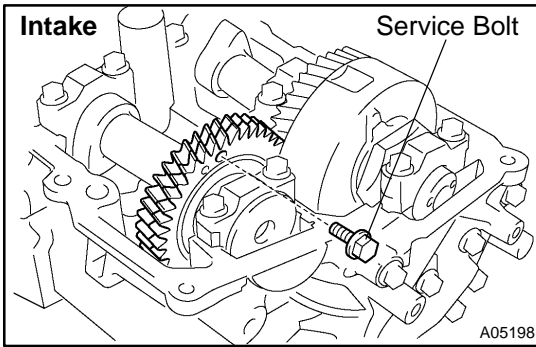

(7) Remove the service bolt.

**7. CHECK AND ADJUST VALVE CLEARANCE**  
(See page EM-4)

Turn the camshaft and position the cam lobe upward, and check and adjust the valve clearance.

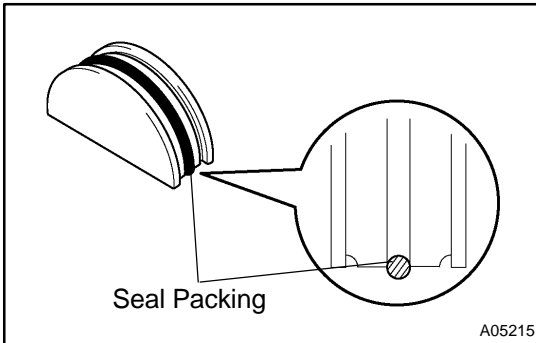

**8. INSTALL SEMI-CIRCULAR PLUGS**

(a) Remove any old packing (FIPG) material.

(b) Apply seal packing to the semi-circular plug grooves.

**Seal packing: Part No. 08826-00080 or equivalent**

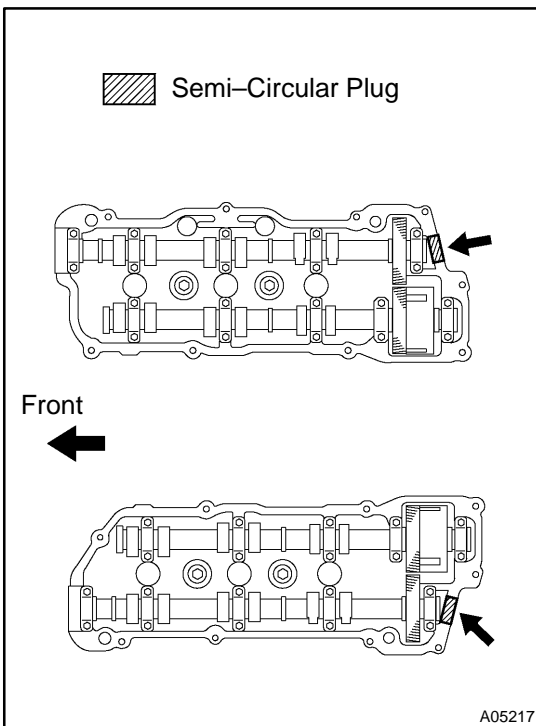

(c) Install the 2 semi-circular plugs to the cylinder heads.

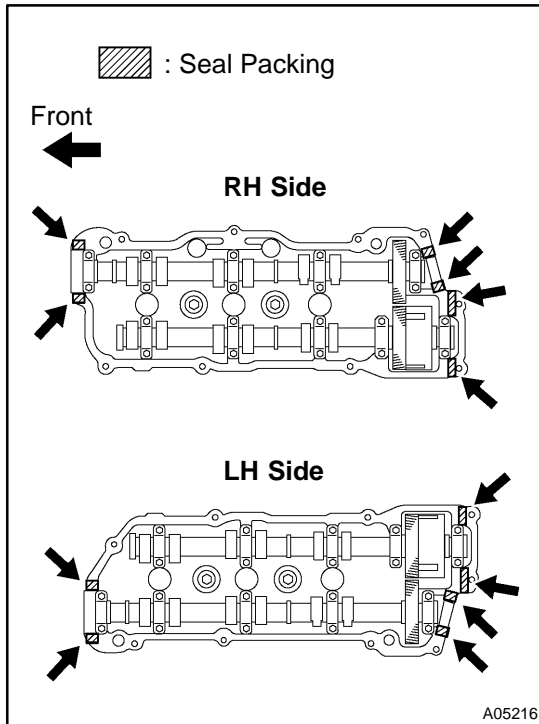

### 9. INSTALL CYLINDER HEAD COVERS

- (a) Apply seal packing to the cylinder heads as shown in the illustration.

**Seal packing: Part No. 08826-00080 or equivalent**

- (b) Install the gasket to the cylinder head cover.  
 (c) Install the cylinder head cover with the 9 bolts. Uniformly tighten the bolts in several passes. Install the 2 cylinder head covers.

**Torque: 8 N·m (80 kgf·cm, 69 in.-lbf)**

### 10. INSTALL PS PUMP BRACKET

**Torque: 43 N·m (440 kgf·cm, 32 ft-lbf)**

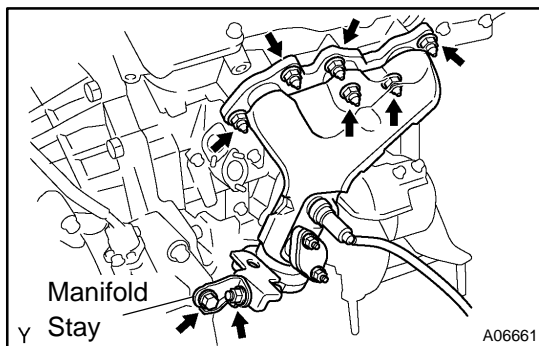

### 11. INSTALL RH EXHAUST MANIFOLD

- (a) Install a new gasket and the exhaust manifold with the 6 nuts. Uniformly tighten the nuts in several passes.

**Torque: 49 N·m (500 kgf·cm, 36 ft-lbf)**

- (b) Install the exhaust manifold stay with the bolt and nut. Alternately tighten the bolt and nut.

**Torque: 34 N·m (350 kgf·cm, 25 ft-lbf)**

- (c) Connect the A/F sensor connector.

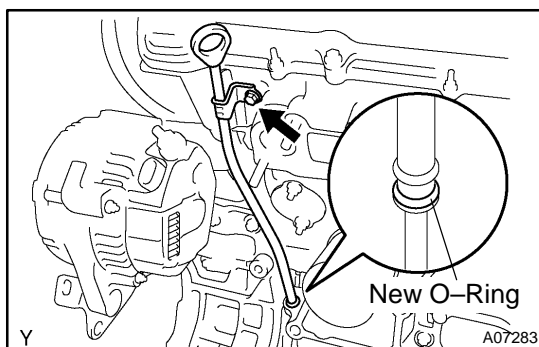

### 12. INSTALL OIL DIPSTICK AND GUIDE

- (a) Install a new O-ring to the dipstick guide.  
 (b) Apply soapy water to the O-ring.  
 (c) Push in the dipstick guide end into the guide hole of the No.1 oil pan.

- (d) Install the dipstick guide with the bolt.

**Torque: 8 N·m (80 kgf·cm, 69 in.-lbf)**

- (e) Install the dipstick.

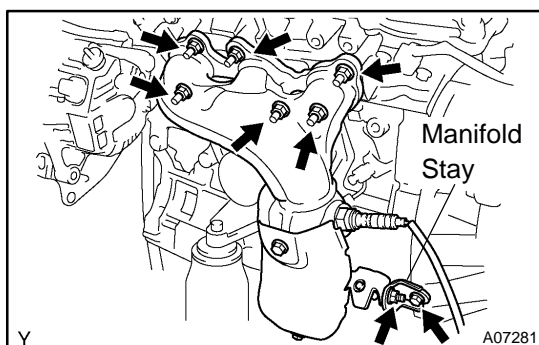

### 13. INSTALL LH EXHAUST MANIFOLD

- (a) Install a new gasket and the exhaust manifold with the 6 nuts. Uniformly tighten the nuts in several passes.

**Torque: 49 N·m (500 kgf·cm, 36 ft-lbf)**

- (b) Install the exhaust manifold stay with the bolt and nut. Alternately tighten the bolt and nut.

**Torque: 34 N·m (350 kgf·cm, 25 ft-lbf)**

- (c) Connect the A/F sensor connector.

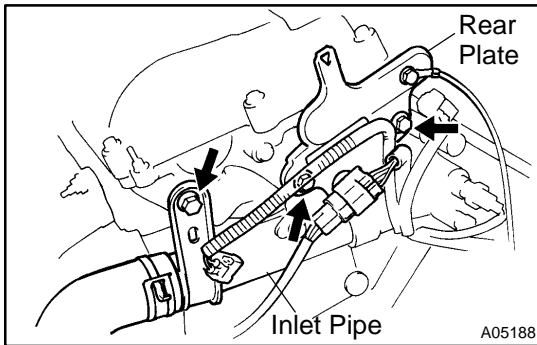
**14. INSTALL WATER INLET PIPE**

- (a) Install a new O-ring to the water inlet pipe.
- (b) Apply soapy water to the O-ring.
- (c) Connect the water inlet pipe to the water inlet.
- (d) Install the bolt holding the water inlet pipe to the cylinder head.

**Torque: 19.5 N·m (200 kgf·cm, 14 ft·lbf)**

**15. INSTALL CYLINDER HEAD REAR PLATE**

**Torque: 8 N·m (80 kgf·cm, 69 in.-lbf)**

**16. INSTALL ENGINE WIRE PROTECTOR****17. INSTALL CAMSHAFT TIMING OIL CONTROL VALVES****18. INSTALL CAMSHAFT POSITION SENSORS****19. INSTALL NO.3 TIMING BELT COVER**

- (a) Check that the timing belt cover gaskets have no cracks or peeling, etc.

If the gaskets have cracks or peeling etc., replace them using these steps:

- Using a screwdriver and gasket scraper, remove all the old gasket material.
- Thoroughly clean all components to remove all the loose material.

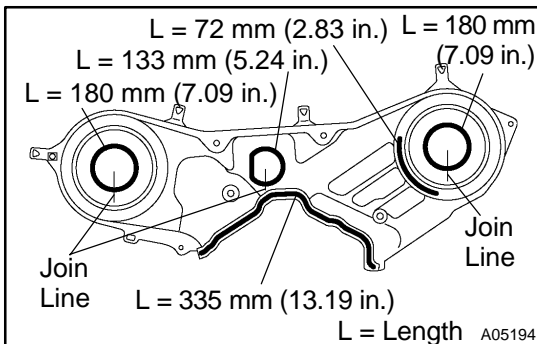

- Remove the backing paper from a new gasket and install the gasket evenly to the part of the timing belt cover shaded black in the illustration.

**NOTICE:**

**When joining 2 gaskets, do not leave a gap between them. Cut off any excess gasket.**

- After installing the gasket, press down on it so that the adhesive firmly sticks to the timing belt cover.
- (b) Install the timing belt cover with the 6 bolts.

**Torque: 8.5 N·m (85 kgf·cm, 74 in.-lbf)**

- (c) Install the 3 engine wire clamps to the timing belt cover.

**20. INSTALL NO.2 IDLER PULLEY (See page EM-21)****21. INSTALL CAMSHAFT TIMING PULLEYS**

(See page EM-21)

**22. INSTALL TIMING BELT (See page EM-21)****23. INSTALL SPARK PLUGS****24. INSTALL IGNITION COILS**

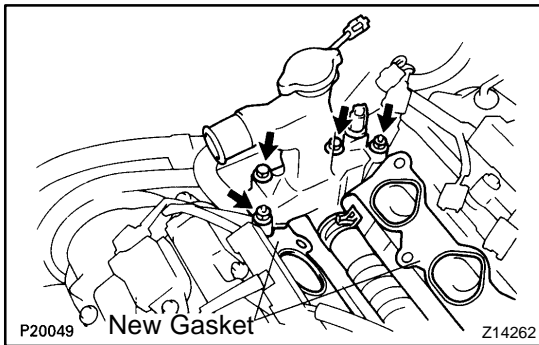
**25. INSTALL WATER OUTLET**

- (a) Install 2 new gaskets.
- (b) Connect the water outlet to the bypass hose.
- (c) Install the water outlet with the 2 bolts, 2 nuts and 2 plate washers. Alternately tighten the bolts and nuts.

**Torque: 15 N·m (150 kgf·cm, 11 ft·lbf)**

**NOTICE:**

**Do not scratch the seal surface of the water outlet with the stud bolt.**

- (d) Connect the ECT sender gauge connector.
- (e) Connect the ECT sensor connector.
- (f) Connect the ground strap connector.
- (g) Connect the upper radiator hose.
- (h) Connect the engine coolant reservoir hose.

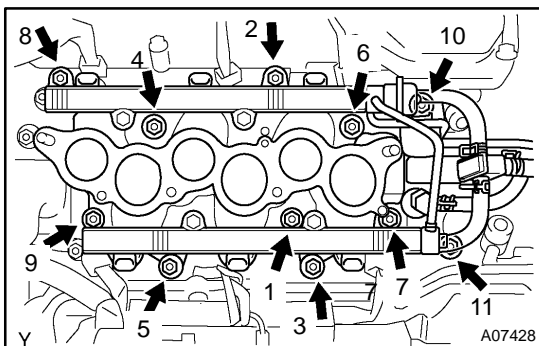
**26. INSTALL INTAKE MANIFOLD ASSEMBLY**

- (a) Install the intake manifold, delivery pipe and injectors assembly with the 9 bolts, 2 plate washers and 2 nuts. Uniformly tighten the bolts and nuts in several passes and in the sequence shown.

**Torque: 15 N·m (150 kgf·cm, 11 ft·lbf)**

- (b) Connect the fuel inlet hose to the fuel filter.

**CAUTION:**

**Perform connecting operations of the fuel tube connector (quick type) after observing the precaution.**

**(See page SF-1)**

- (c) Connect the heater hose to the intake manifold.

**27. RETIGHTEN WATER OUTLET MOUNTING BOLTS AND NUTS**

Tighten the 2 bolts and 2 nuts.

**Torque: 15 N·m (150 kgf·cm, 11 ft·lbf)**

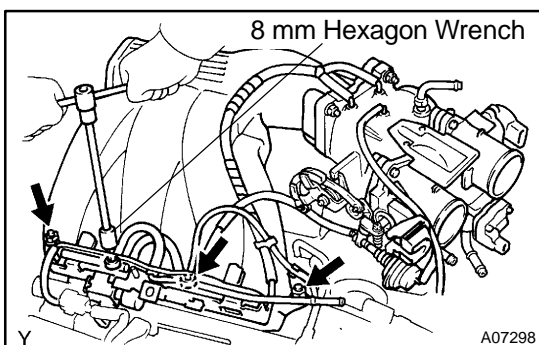
**28. INSTALL AIR INTAKE CHAMBER ASSEMBLY**

- (a) Using an 8 mm hexagon wrench, install a new gasket and the air intake chamber assembly with the 2 bolts and 2 nuts. Uniformly tighten the bolts and nuts in several passes.

**Torque: 43 N·m (440 kgf·cm, 32 ft·lbf)**

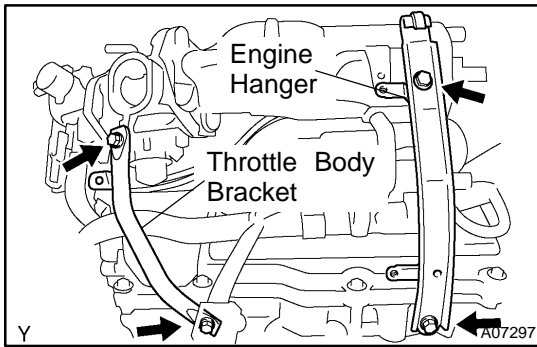

- (b) Install the No.1 engine hanger with the 2 bolts.  
**Torque: 39 N·m (400 kgf·cm, 29 ft·lbf)**
- (c) Install the throttle body bracket with the 2 bolts.  
**Torque: 19.5 N·m (200 kgf·cm, 14 ft·lbf)**
- (d) Connect the PCV hose to the PCV valve on the RH cylinder head.
- (e) Connect the ground strap and cable to the intake air control valve for the ACIS.
- (f) Connect the ground cable and strap with the nut.  
**Torque: 14.5 N·m (145 kgf·cm, 10 ft·lbf)**
- (g) Connect the ground cable to the air intake chamber.
- (h) Connect the brake booster vacuum hose to the throttle body.
- (i) Connect the 2 water bypass hoses to the throttle body.
- (j) Connect the air assist hose to the throttle body.
- (k) Connect the purge hose to the emission control valve set.
- (l) Connect the 2 vacuum hoses to the vacuum tank for ACIS.
- (m) Connect the engine wire clamp to the emission control valve set.
- (n) Install the PS pressure tube with the 2 nuts.
- (o) Connect the throttle position sensor connector.
- (p) Connect the IAC valve connector.
- (q) Connect the No.1 VSV connector for the ACIS.
- (r) Connect the No.2 VSV connector for the ACIS.
- (s) Connect the VSV connector for the EVAP.
- (t) Connect the DLC1 to the bracket on the intake air control valve.
- (u) Connect the accelerator cable.

## 29. INSTALL AIR FILTER AND AIR CLEANER CAP ASSEMBLY

### 30. INSTALL V-BANK COVER

- (a) Using a 5 mm hexagon wrench, install the V-bank cover with the 3 cap nuts.
- (b) Press down the V-bank cover fastener.

### 31. INSTALL FRONT EXHAUST PIPE

(See page [EM-77](#))

### 32. INSTALL PS PUMP (See page [SR-27](#))

### 33. INSTALL GENERATOR DRIVE BELT

(See page [CH-16](#))

### 34. FILL WITH ENGINE COOLANT

### 35. START ENGINE AND CHECK FOR LEAKS

### 36. VEHICLE ROAD TEST

Check for abnormal noise, shock, slippage, correct shift points and smoothly operation.

### 37. RECHECK ENGINE COOLANT LEVEL

# ENGINE UNIT COMPONENTS

EM02K-01

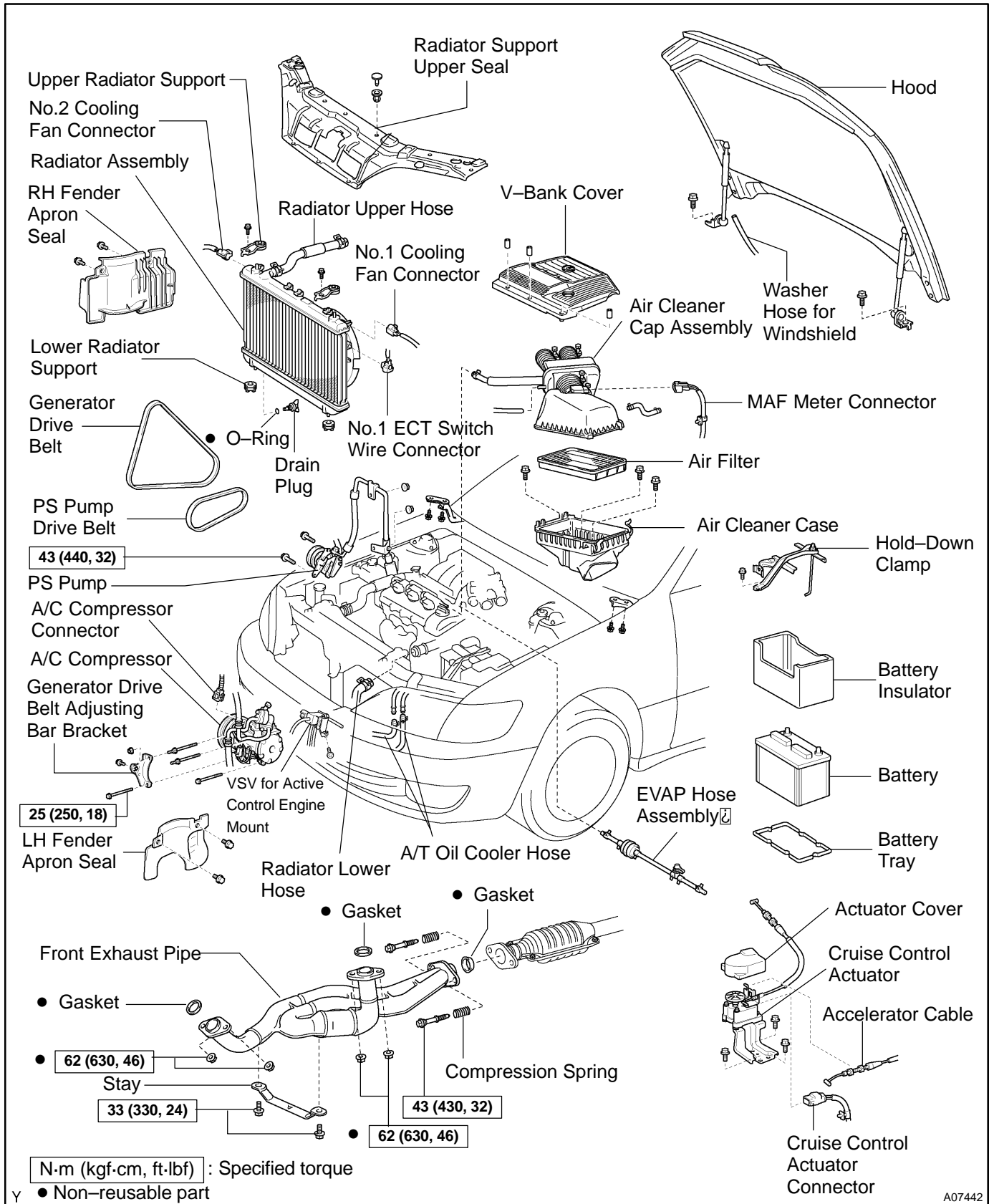

A07442

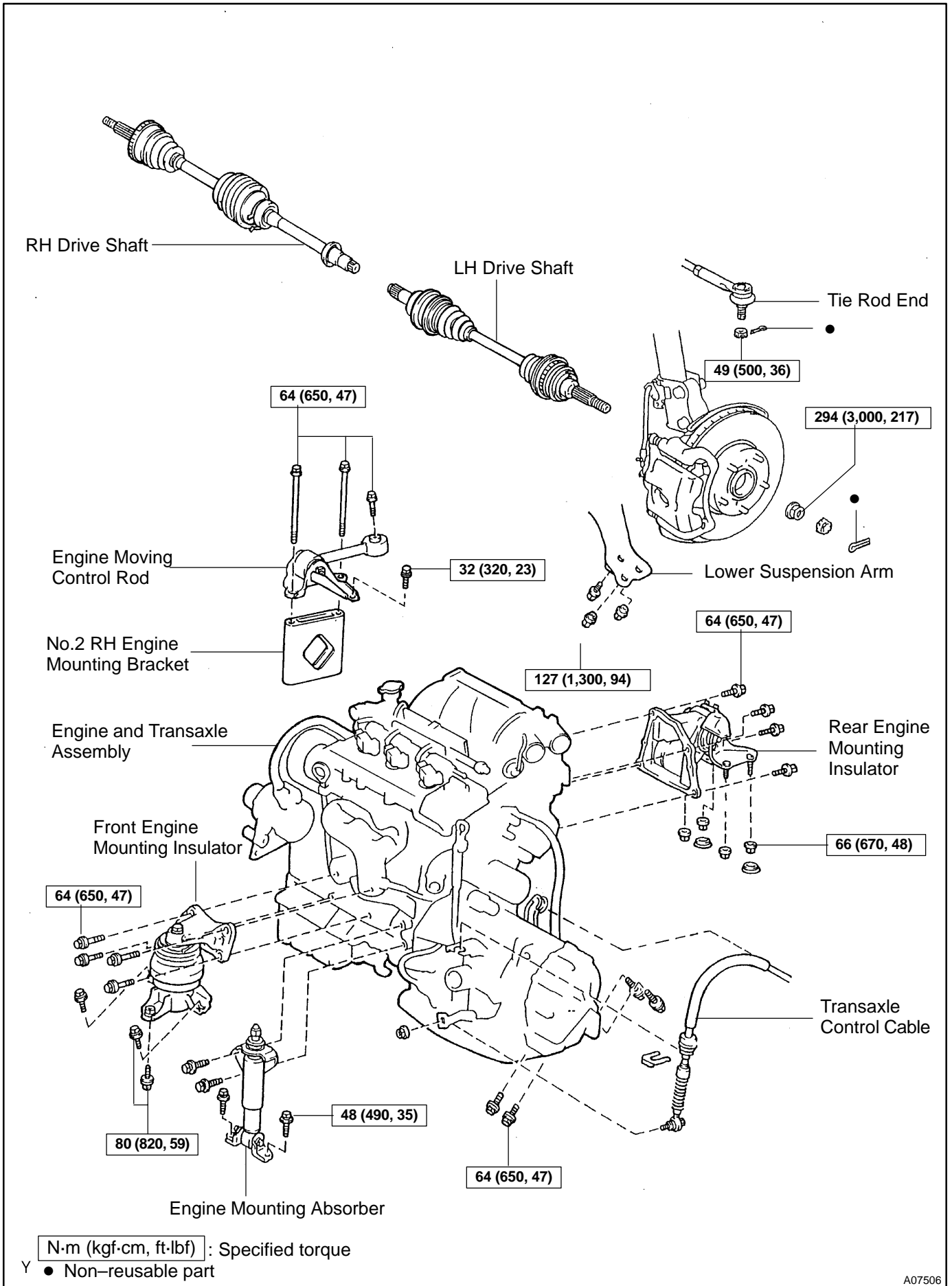

A07506

## REMOVAL

1. REMOVE BATTERY AND TRAY
2. REMOVE HOOD
3. REMOVE ENGINE FENDER APRON SEALS
4. DRAIN ENGINE COOLANT
5. DRAIN ENGINE OIL

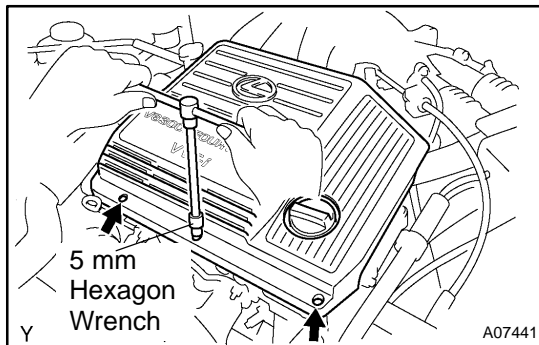

6. REMOVE V-BANK COVER
  - (a) Using a 5 mm hexagon wrench, remove the 3 cap nuts.
  - (b) Loosen the V-bank cover fastener counterclockwise.
  - (c) Remove the V-bank cover.
7. DISCONNECT ACCELERATOR CABLE
8. REMOVE AIR CLEANER CAP ASSEMBLY AND AIR CLEANER CASE
9. REMOVE CRUISE CONTROL ACTUATOR
10. REMOVE RADIATOR (See page [CO-18](#))

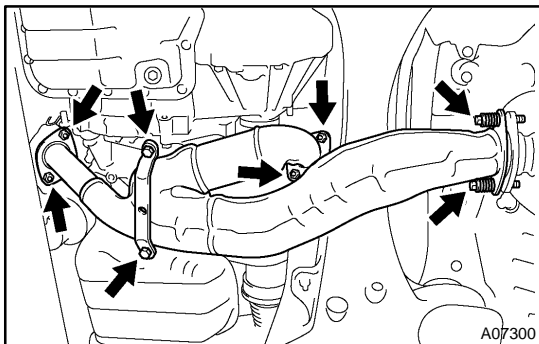

11. REMOVE FRONT EXHAUST PIPE
  - (a) Remove the 2 bolts holding the support stay to the support bracket.
  - (b) Remove the 2 bolts and 2 compression springs holding the front exhaust pipe to the center exhaust pipe.
  - (c) Remove the 4 nuts holding the front exhaust pipe to the exhaust manifolds.
  - (d) Remove the front exhaust pipe and 3 gaskets.
12. DISCONNECT CONNECTORS, CABLE, CLAMPS AND HOSES
  - (a) Disconnect the noise filter connector on the LH fender apron.
  - (b) Disconnect the generator wire and connector.
  - (c) Disconnect the starter wire and connector.
  - (d) Remove the bolt and disconnect the ground strap from the LH fender apron.
  - (e) Disconnect the 2 ground strap connectors from the RH fender apron.
  - (f) Disconnect the ground cable from the battery body bracket.
  - (g) Disconnect the engine wire protector clamp from the battery body bracket.
  - (h) Disconnect the engine wire clamp from the bracket on the RH fender apron.
  - (i) Disconnect the brake booster vacuum hose from the throttle body.
  - (j) Disconnect the engine coolant reservoir hose from the water outlet.
  - (k) Disconnect the heater hose from the intake manifold.
  - (l) Disconnect the heater hose from the water inlet housing.

(m) Disconnect the fuel inlet hose from the fuel filter.

**CAUTION:**

**Perform disconnecting operation of the fuel tube connector (quick type) after observing the precautions (See page SF-1).**

- (n) Disconnect the EVAP hose assembly from the pipe on the emission control valve set.
- (o) Disconnect the 2 vacuum hoses from the vacuum tank for the ACIS.

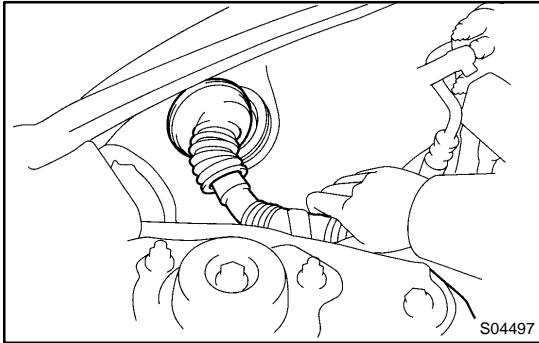

**13. DISCONNECT ENGINE WIRE FROM CABIN**

- (a) Remove the No.2 instrument lower panel.
- (b) Disconnect the 3 ECM connectors.
- (c) Disconnect the 3 cowl wire connectors from the connectors on the bracket.
- (d) Disconnect the grommet from the cowl panel, and pull out the engine wire.

**14. REMOVE DRIVE SHAFTS (See page SA-16)**

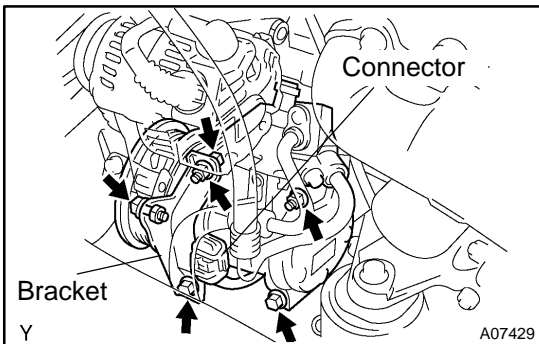

**15. DISCONNECT A/C COMPRESSOR FROM ENGINE**

- (a) Disconnect the A/C compressor connector.
- (b) Remove the drive belt.
- (c) Remove the 2 bolts, nut and drive belt adjusting bar bracket.
- (d) Remove the 3 bolts and disconnect the A/C compressor from the engine.

**16. DISCONNECT TRANSAXLE CONTROL CABLE FROM TRANSAXLE**

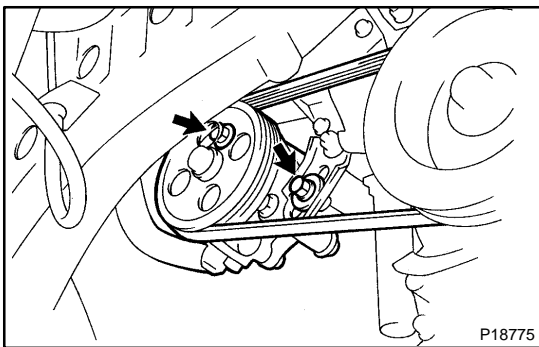

**17. DISCONNECT PS PUMP FROM ENGINE**

- (a) Remove the 2 nuts, and disconnect the PS pressure tube from the No.1 engine hanger.
- (b) Loosen the 2 bolts, and remove the drive belt.
- (c) Remove the 2 bolts, and disconnect the PS pump from the engine.

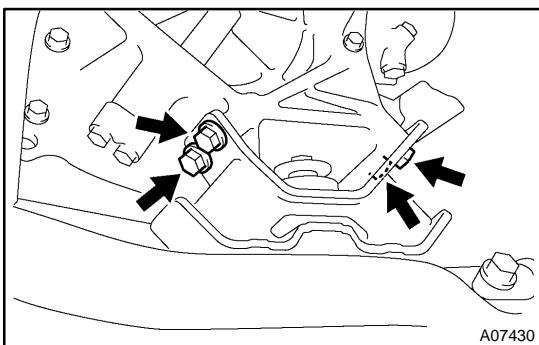

**18. DISCONNECT TRANSAXLE FROM LH ENGINE MOUNTING INSULATOR**

Remove the 4 bolts holding the transaxle to the mounting insulator.

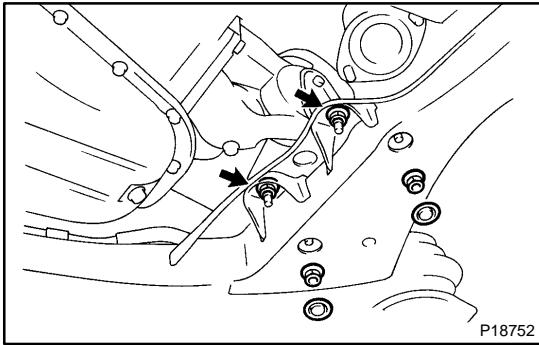

### 19. DISCONNECT REAR ENGINE MOUNTING BRACKET FROM FRONT FRAME

- (a) Remove the 2 hole plugs.
- (b) Remove the 4 nuts holding the front frame to the mounting bracket.

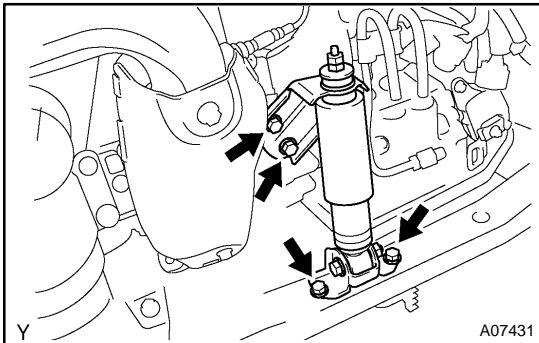

### 20. REMOVE ENGINE MOUNTING ABSORBER

Remove the 4 bolts and mounting absorber.

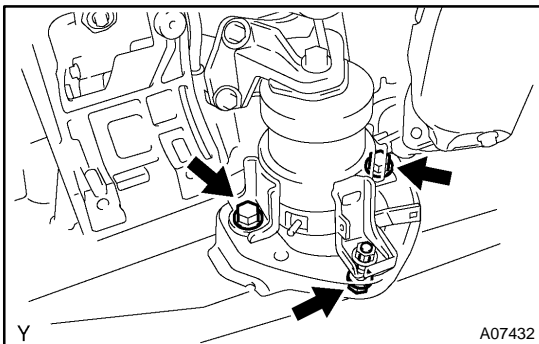

### 21. DISCONNECT FRONT ENGINE MOUNTING INSULATOR FROM FRONT FRAME

Remove the 3 bolts holding the mounting insulator to the front frame.

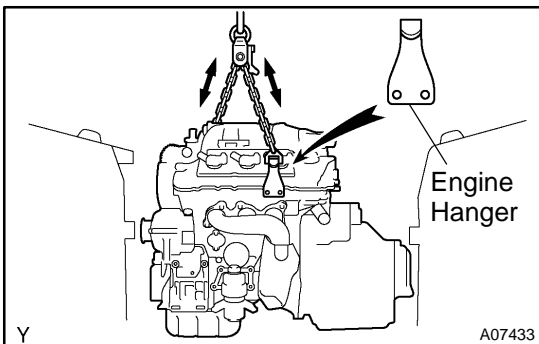

### 22. ATTACH ENGINE SLING DEVICE TO ENGINE HANGERS

- (a) Install the No.2 engine hanger in the correct direction.

**Part No.:**

No.2 engine hanger	12282-20020
Bolt	91621-60822

**Torque: 19.5 N·m (200 kgf·cm, 14 ft·lbf)**

- (b) Attach the sling device to the engine hangers.

**CAUTION:**

**Do not attempt to hang the engine by hooking the chain to any other part.**

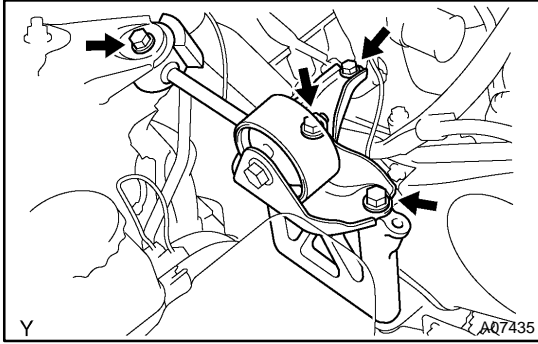

**23. REMOVE ENGINE MOVING CONTROL ROD AND NO.2 RH ENGINE MOUNTING BRACKET**

Remove the 4 bolts, control rod and mounting bracket.

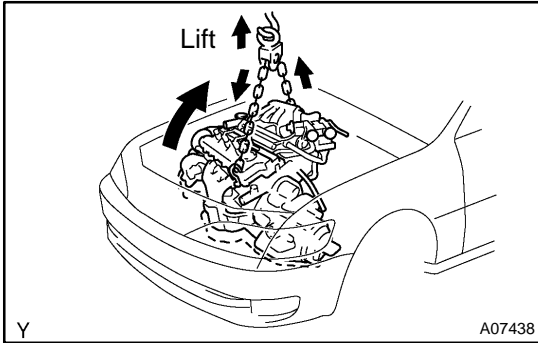

**24. REMOVE ENGINE AND TRANSAXLE ASSEMBLY FROM VEHICLE**

(a) Lift the engine out of the vehicle slowly and carefully.

**NOTICE:**

- Be careful not to hit the PNP switch.
- Make sure the engine is clear of all wiring, hoses and cables.

(b) Place the engine and transaxle assembly onto the stand.

**25. REMOVE FRONT ENGINE MOUNTING INSULATOR FROM ENGINE**

Remove the 4 bolts and mounting insulator.

**26. REMOVE REAR ENGINE MOUNTING INSULATOR AND BRACKET ASSEMBLY FROM ENGINE**

Remove the 4 bolts, the mounting insulator and bracket assembly.

**27. SEPARATE ENGINE AND TRANSAXLE**

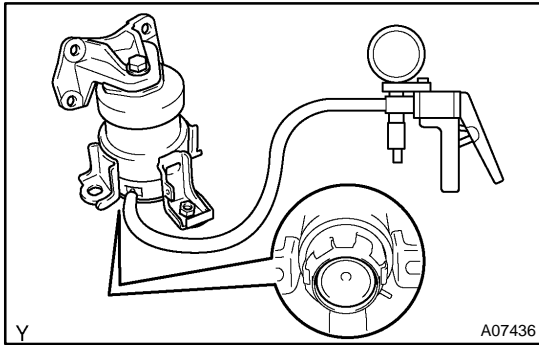

## INSPECTION

### 1. INSPECT FRONT ENGINE MOUNTING INSULATOR

- Using a MITYVAC (Hand-Held Vacuum Pump), apply vacuum of 80 kPa (600 mmHg, 25 in.Hg) and allow it to stand for 1 minute.
- Check that there is no change in the needle movement.
- Check that there is no fluid leakage caused by a break of a lower diaphragm.

If the operation is not as specified, replace the insulator.

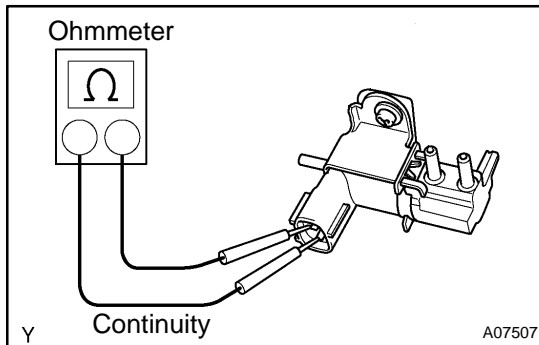

### 2. INSPECT VSV FOR ACTIVE CONTROL ENGINE MOUNT

- Inspect the VSV for open circuit. Using an ohmmeter, check that there is continuity between the terminals.

**Resistance: 19 – 21  $\Omega$  at 20°C (68°F)**

If there is no continuity, replace the VSV.

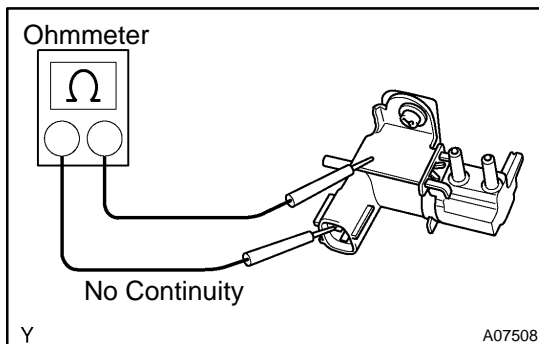

- Inspect the VSV for ground. Using an ohmmeter, check that there is no continuity between each terminal and the body.

If there is continuity, replace the VSV.

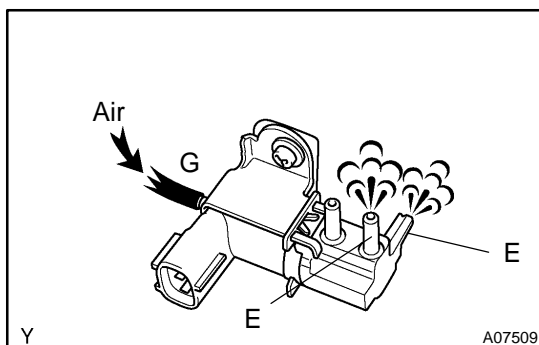

- Inspect the VSV operation.

- Check that air flows from port G to port E.

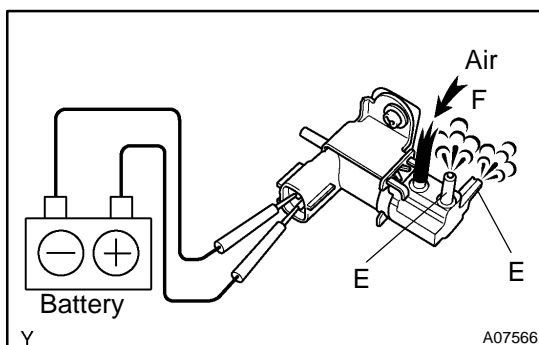

- Apply battery positive voltage across the terminals.

- Check that air flows from port F to port E.

If operation is not as specified, replace the VSV.

### 3. INSPECT VACUUM TANK

(See page [SF-56](#))

## INSTALLATION

1. ASSEMBLE ENGINE AND TRANSAXLE
2. INSTALL REAR ENGINE MOUNTING INSULATOR

Install the mounting insulator with the 4 bolts.

**Torque: 64 N·m (650 kgf·cm, 47 ft·lbf)**

3. INSTALL FRONT ENGINE MOUNTING INSULATOR

Install the mounting insulator with the 4 bolts.

**Torque: 64 N·m (650 kgf·cm, 47 ft·lbf)**

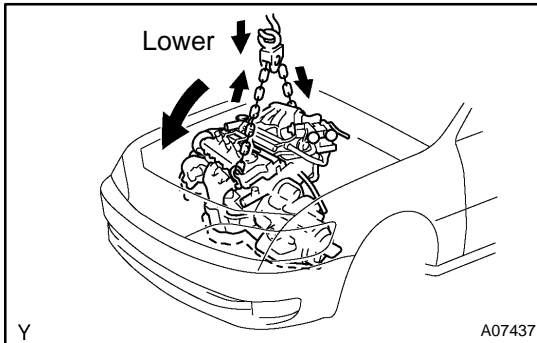

4. INSTALL ENGINE AND TRANSAXLE ASSEMBLY IN VEHICLE

- (a) Attach the engine sling device to the engine hangers.
- (b) Lower the engine into the engine compartment.  
Tilt the transaxle downward, lower the engine and clear the LH mounting.

### NOTICE:

**Be careful not to hit the park/neutral position switch.**

- (c) Keep the engine level, and align RH and LH mountings with the body bracket.

5. INSTALL NO.2 RH ENGINE MOUNTING BRACKET AND ENGINE MOVING CONTROL ROD

- (a) Temporarily install the No.2 RH engine mounting bracket and engine moving control rod with the 3 bolts.

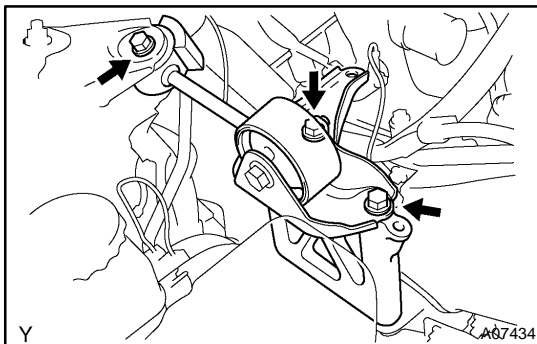

- (b) Tighten the bolt (A).
- Torque: 64 N·m (650 kgf·cm, 47 ft·lbf)**
- (c) Tighten the other 3 bolts (B, C and D).

**Torque:**

**64 N·m (650 kgf·cm, 47 ft·lbf) for bolt B and C**

**32 N·m (320 kgf·cm, 23 ft·lbf) for bolt D**

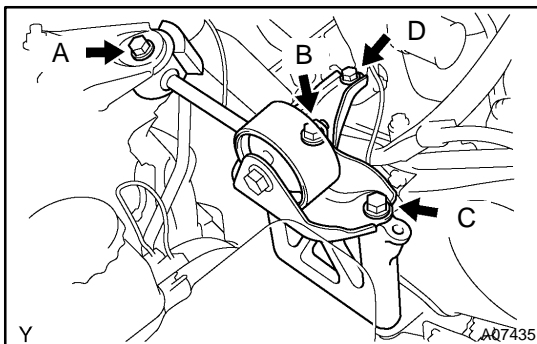

6. CONNECT FRONT ENGINE MOUNTING INSULATOR

Connect the mounting insulator with the 3 bolts.

**Torque: 80 N·m (820 kgf·cm, 59 ft·lbf)**

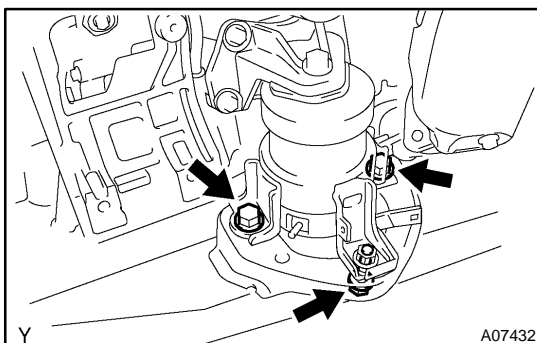

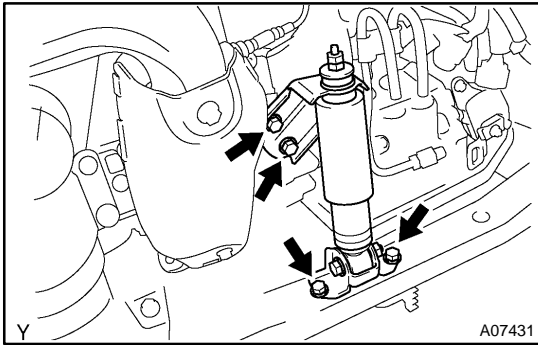
**7. INSTALL ENGINE MOUNTING ABSORBER**

Install the engine mounting absorber with the 4 bolts.

**Torque: 48 N·m (490 kgf·cm, 35 ft·lbf)**

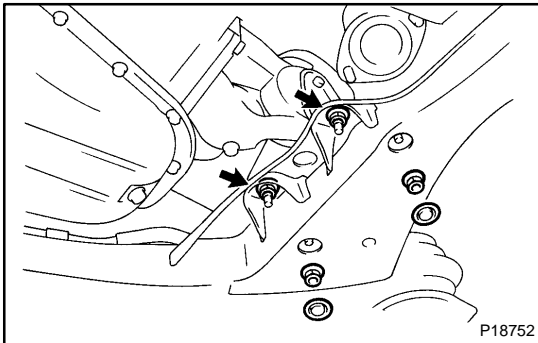
**8. CONNECT REAR ENGINE MOUNTING INSULATOR**

(a) Connect the mounting insulator with the 4 nuts.

**Torque: 66 N·m (670 kgf·cm, 48 ft·lbf)**

(b) Install the 2 hole plugs.

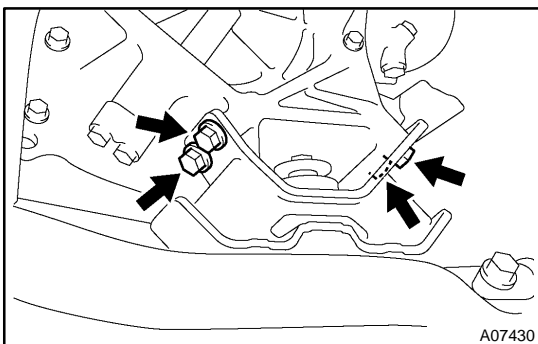
**9. CONNECT LH ENGINE MOUNTING INSULATOR**

Connect the mounting insulator with the 4 bolts.

**Torque: 64 N·m (650 kgf·cm, 47 ft·lbf)**

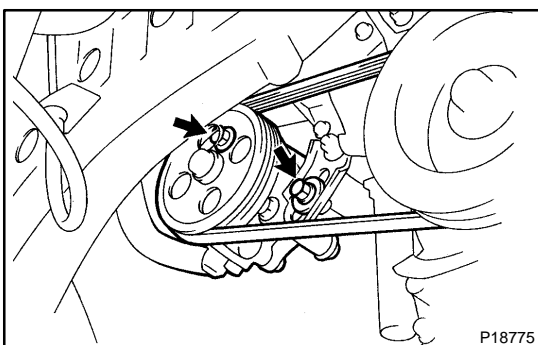
**10. REMOVE ENGINE SLING DEVICE****11. CONNECT TRANSAXLE CONTROL CABLE TO TRANSAXLE****12. INSTALL PS PUMP**

(a) Install the PS pump with the 2 bolts.

**Torque: 43 N·m (440 kgf·cm, 31 ft·lbf)**

(b) Install the drive belt.

(c) Connect the PS pressure tube with the 2 nuts.

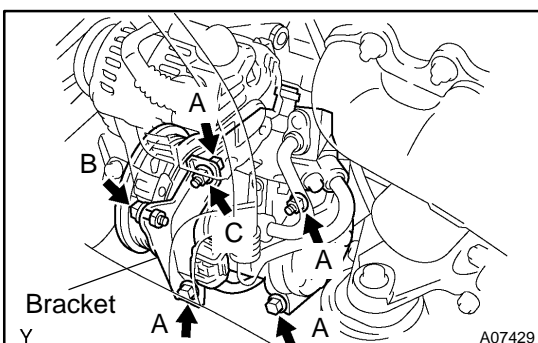
**13. INSTALL A/C COMPRESSOR**

(a) Install the A/C compressor and drive belt adjusting bar bracket with the 5 bolts and nut.

**Torque:**

**25 N·m (250 kgf·cm, 18 ft·lbf) for bolt A**

**18 N·m (185 kgf·cm, 13 ft·lbf) for bolt B**

**25 N·m (250 kgf·cm, 18 ft·lbf) for nut C**

(b) Install the drive belt.

(c) Connect the A/C compressor connector.

**14. INSTALL DRIVE SHAFTS (See page SA-23)**

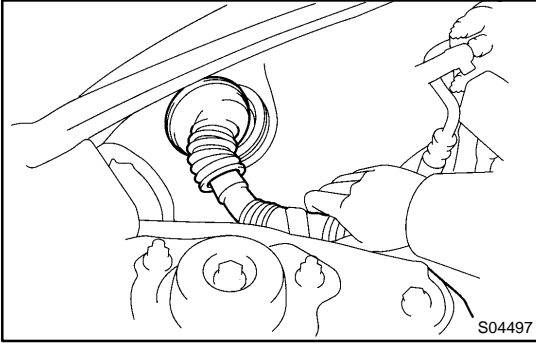
**15. CONNECT ENGINE WIRE TO CABIN**

- (a) Push in the engine wire through the cowl panel. Install the grommet.
- (b) Connect the 3 engine ECM connectors.
- (c) Connect the 3 cowl wire connectors to the connectors on the bracket.
- (d) Install the No.2 instrument lower panel.

**16. CONNECT CONNECTORS, CABLE, CLAMPS AND HOSES**

- (a) Connect the noise filter connector on the LH fender apron.
- (b) Connect the generator connector and wire.
- (c) Connect the starter connector and wire.
- (d) Connect the 2 ground strap connectors to the RH fender apron
- (e) Connect the strap connector to the LH fender apron with the bolt.
- (f) Connect the ground cable to the battery body bracket.
- (g) Connect the engine wire protector clamp to the battery body bracket.
- (h) Connect the engine wire clamp to the bracket on the RH fender apron.
- (i) Connect the brake booster vacuum hose to the throttle body.
- (j) Connect the engine coolant reservoir hose to the water outlet.
- (k) Connect the heater hose to the intake manifold.
- (l) Connect the heater hose to the water inlet housing.
- (m) Connect the fuel inlet hose to the fuel filter.

**CAUTION:**

**Perform connecting operations of the fuel tube connector (quick type) after observing the precautions.**

**(See page SF-1)**

- (n) Connect the EVAP hose assembly to the pipe on the emission control valve set.
- (o) Connect the 2 vacuum hoses to the vacuum tank for the ACIS.

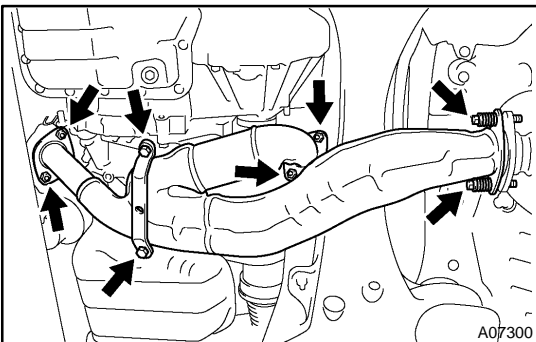
**17. INSTALL FRONT EXHAUST PIPE**

- (a) Temporarily install 3 new gaskets and the front exhaust pipe with the 2 bolts, 2 compression springs and 4 nuts.
- (b) Tighten the 4 nuts holding the exhaust manifolds to the front exhaust pipe.

**Torque: 62 N·m (630 kgf-cm, 46 ft-lbf)**

- (c) Tighten the 2 bolts and 2 compression springs holding the front exhaust pipe to the center exhaust pipe.

**Torque: 43 N·m (440 kgf-cm, 32 ft-lbf)**

- (d) Install the support stay with the 2 bolts.  
**Torque: 33 N·m (330 kgf-cm, 24 ft-lbf)**
- 18. INSTALL RADIATOR (See page CO-24)**
- 19. INSTALL CRUISE CONTROL ACTUATOR**
- 20. INSTALL AIR CLEANER CAP ASSEMBLY AND AIR CLEANER CASE**
- 21. CONNECT ACCELERATOR CABLE**
- 22. INSTALL V-BANK COVER**
- (a) Using a 5 mm hexagon wrench, install the V-bank cover with the 3 cap nuts.
- (b) Press down the V-bank cover fastener.
- 23. INSTALL ENGINE FENDER APRON SEALS**
- 24. INSTALL BATTERY TRAY AND BATTERY**
- 25. INSTALL HOOD**
- 26. FILL ENGINE WITH OIL**
- 27. FILL WITH ENGINE COOLANT**
- 28. START ENGINE AND CHECK FOR LEAKS**
- 29. PERFORM ROAD TEST**
- Check for abnormal noise, shock, slippage, correct shift points and smooth operation.
- 30. RECHECK ENGINE COOLANT AND OIL LEVELS**

# CYLINDER BLOCK COMPONENTS

EM04B-02

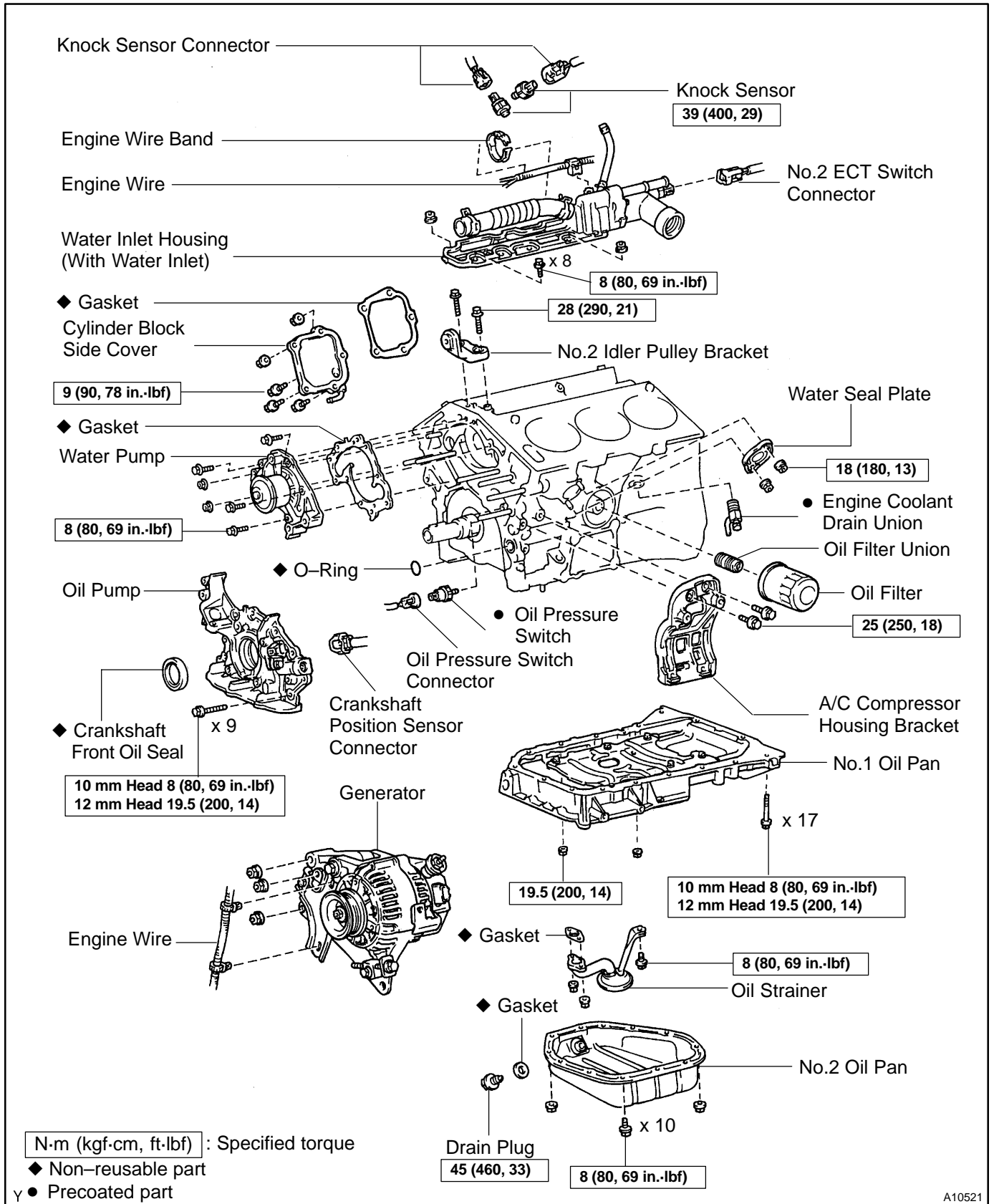

A10521

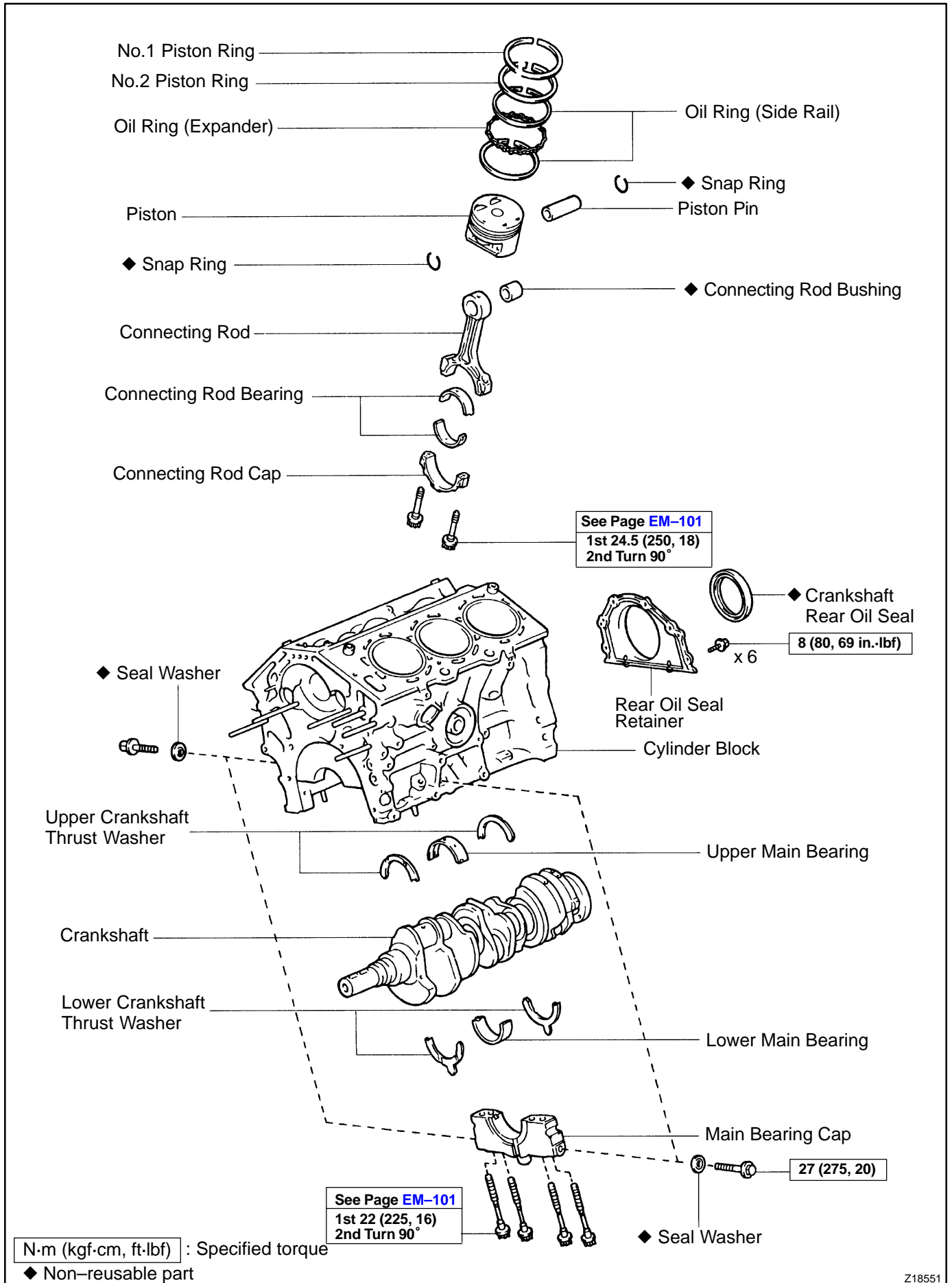

Z18551

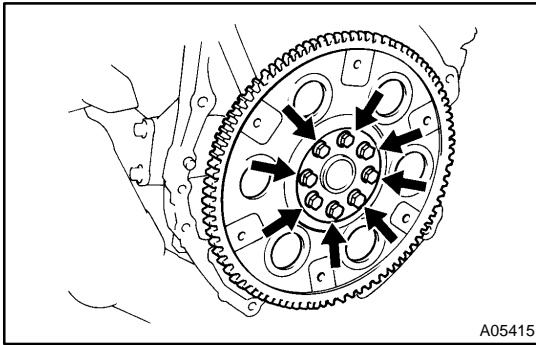

## DISASSEMBLY

### 1. REMOVE DRIVE PLATE

Remove the 8 bolts, rear plate, drive plate and front spacer.

### 2. INSTALL ENGINE TO ENGINE STAND FOR DISASSEMBLY

### 3. REMOVE TIMING BELT AND PULLEYS

(See page [EM-15](#))

### 4. REMOVE CYLINDER HEAD (See page [EM-31](#))

### 5. DISCONNECT CRANKSHAFT POSITION SENSOR CONNECTOR

### 6. DISCONNECT OIL PRESSURE SWITCH CONNECTOR

### 7. DISCONNECT OIL LEVEL SENSOR CONNECTOR

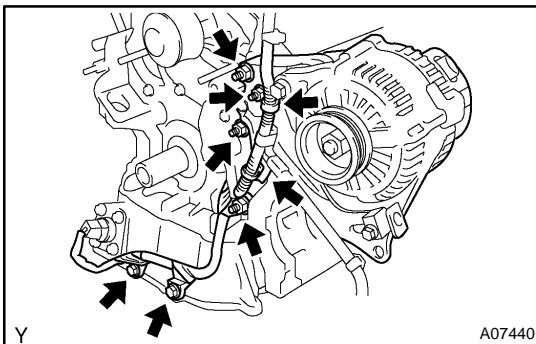

### 8. REMOVE ENGINE WIRE

- (a) Disconnect the 2 wire clamps from the wire brackets.
- (b) Remove the 2 bolts and nut, and disconnect the engine wire.

### 9. REMOVE GENERATOR, ADJUSTING BAR AND BRACKET ASSEMBLY

Remove the 3 nuts, the generator, adjusting bar and bracket assembly.

### 10. REMOVE OIL PRESSURE SWITCH

(See page [LU-1](#))

### 11. REMOVE A/C COMPRESSOR HOUSING BRACKET

Remove the 2 bolts and compressor housing bracket.

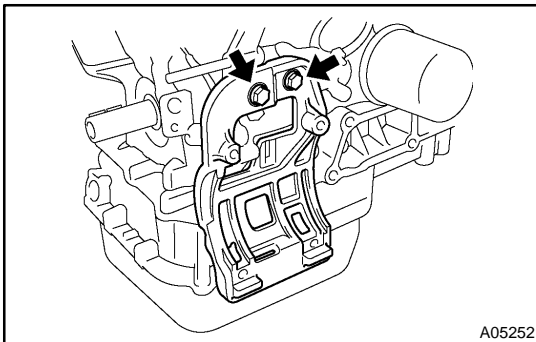

### 12. REMOVE NO.2 IDLER PULLEY BRACKET

Remove the 2 bolts and idler pulley bracket.

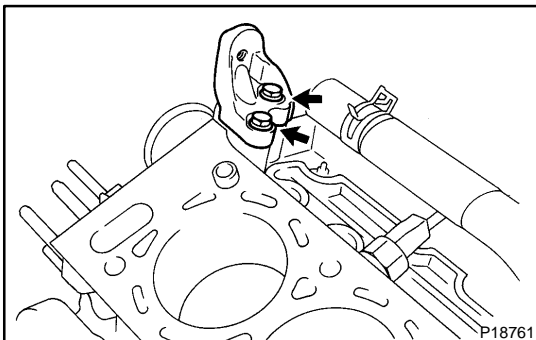

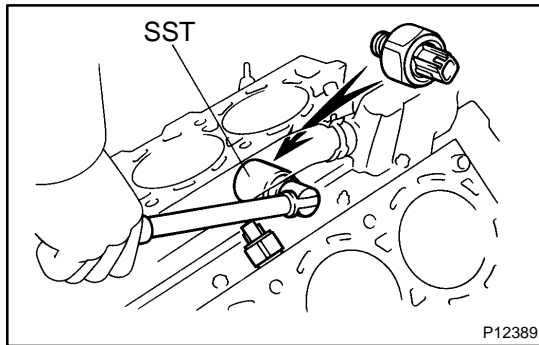
**13. REMOVE KNOCK SENSORS**

- (a) Disconnect the 2 knock sensor connectors.
- (b) Using SST, remove the 2 knock sensors.  
SST 09816-30010

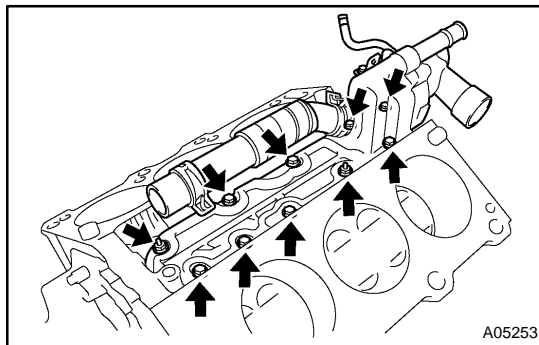
**14. REMOVE WATER INLET HOUSING**

- (a) Remove the engine wire band.
- (b) Disconnect the engine wire clamp from the bracket.
- (c) Remove the 8 bolts, 2 nuts and water inlet housing.

**15. REMOVE WATER PUMP (See page CO-6)****16. REMOVE NO.2 OIL PAN (See page LU-9)****17. REMOVE OIL STRAINER (See page LU-3)****18. REMOVE NO.1 OIL PAN (See page LU-3)****19. REMOVE OIL PUMP (See page LU-9)****20. REMOVE OIL FILTER (See page LU-3)****21. REMOVE OIL FILTER UNION**

Using a 12 mm hexagon wrench, remove the oil filter union.

**22. REMOVE WATER SEAL PLATE**

Remove the 2 nuts and seal plate.

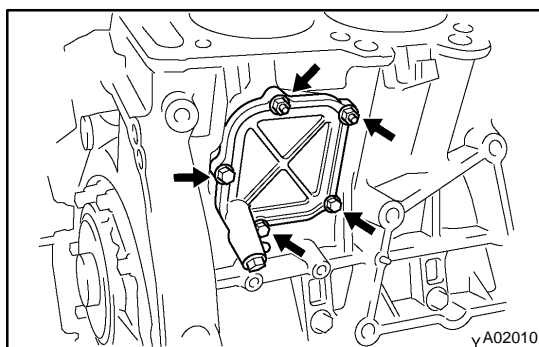
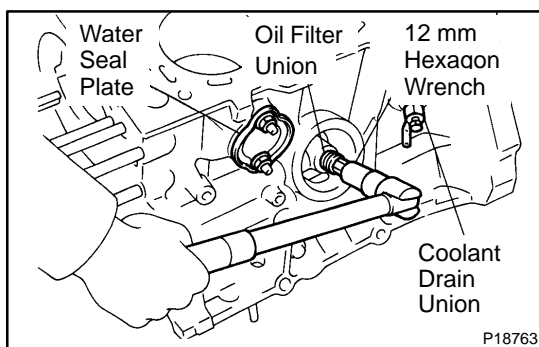
**23. REMOVE ENGINE COOLANT DRAIN UNION****24. REMOVE CYLINDER BLOCK SIDE COVER**

Remove the 3 bolts, 2 nuts, cylinder block side cover and gasket.

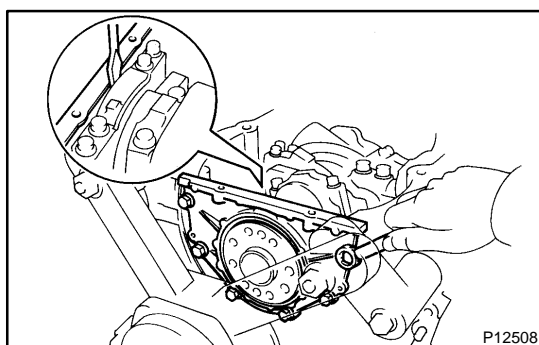
**25. REMOVE REAR OIL SEAL RETAINER**

- (a) Remove the 6 bolts.
- (b) Using a screwdriver, remove the oil seal retainer by prying the portions between the oil seal retainer and main bearing cap.

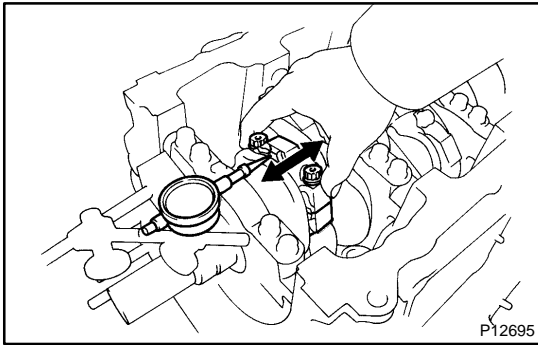

## 26. CHECK CONNECTING ROD THRUST CLEARANCE

Using a dial indicator, measure the thrust clearance while moving the connecting rod back and forth.

**Standard thrust clearance:**

**0.15 – 0.30 mm (0.0059 – 0.0118 in.)**

**Maximum thrust clearance: 0.35 mm (0.0138 in.)**

If the thrust clearance is greater than maximum, replace the connecting rod assembly(s). If necessary, replace the crankshaft.

**Connecting rod thickness:**

**20.80 – 20.85 mm (0.8189 – 0.8209 in.)**

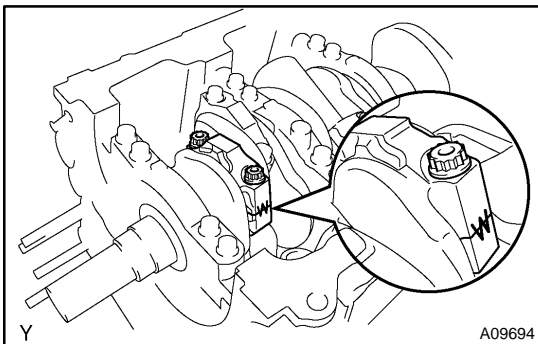

## 27. REMOVE CONNECTING ROD CAPS AND CHECK OIL CLEARANCE

- (a) Check the matchmarks on the connecting rod and cap are aligned to ensure correct reassembly.
- (b) Remove the 2 connecting rod cap bolts.

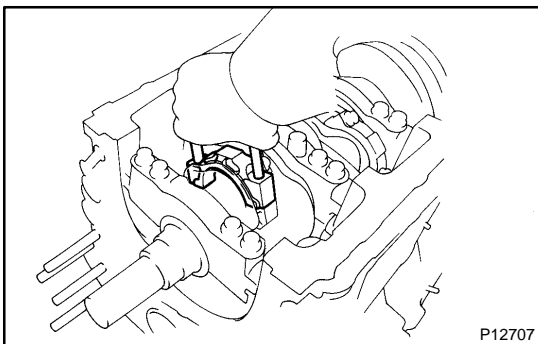

- (c) Using the 2 removed connecting rod cap bolts, remove the connecting rod cap and lower bearing by wiggling the connecting rod cap right and left.

**HINT:**

Keep the lower bearing inserted with the connecting rod cap.

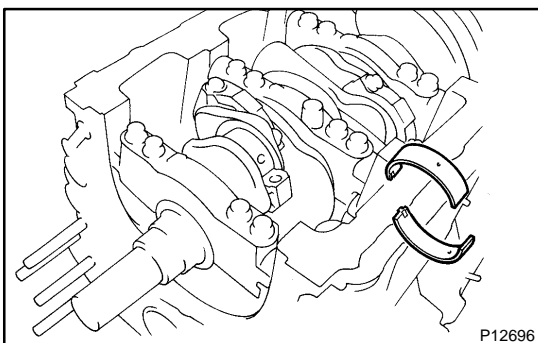

- (d) Clean the crank pin and bearing.
- (e) Check the crank pin and bearing for pitting and scratches. If the crank pin or bearing is damaged, replace the bearings. If necessary, replace the crankshaft.

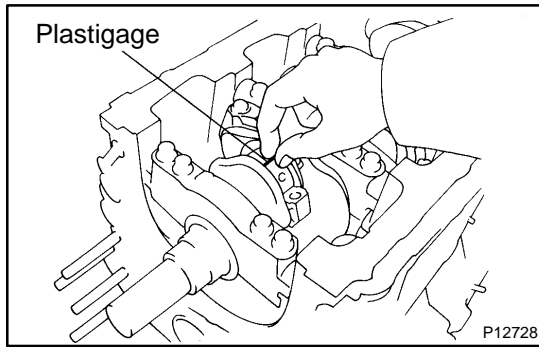

- (f) Lay a strip of Plastigage across the crank pin.

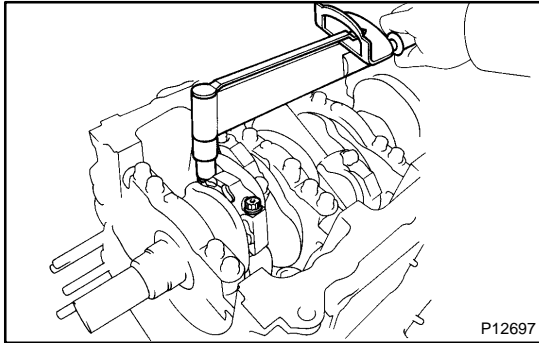

- (g) Install the connecting rod cap with the 2 bolts (See page [EM-101](#)).

**Torque:**

**1st: 24.5 N·m (250 kgf·cm, 18 ft·lbf)**

**2nd: Turn extra 90°**

**NOTICE:**

**Do not turn the crankshaft.**

- (h) Remove the 2 bolts, connecting rod cap and lower bearing (See steps (b) and (c)).

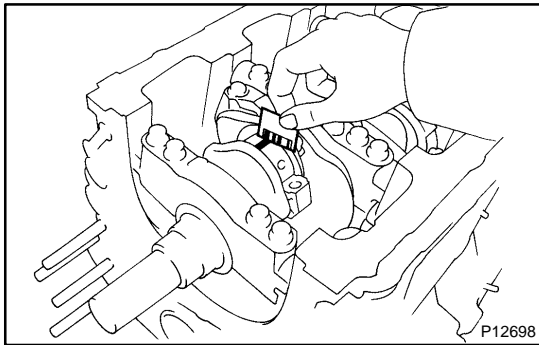

- (i) Measure the Plastigage at its widest point.

**Standard oil clearance:**

**0.038 – 0.064 mm (0.0015 – 0.0025 in.)**

**Maximum oil clearance: 0.08 mm (0.0031 in.)**

If the oil clearance is greater than maximum, replace the bearings. If necessary, grind or replace the crankshaft.

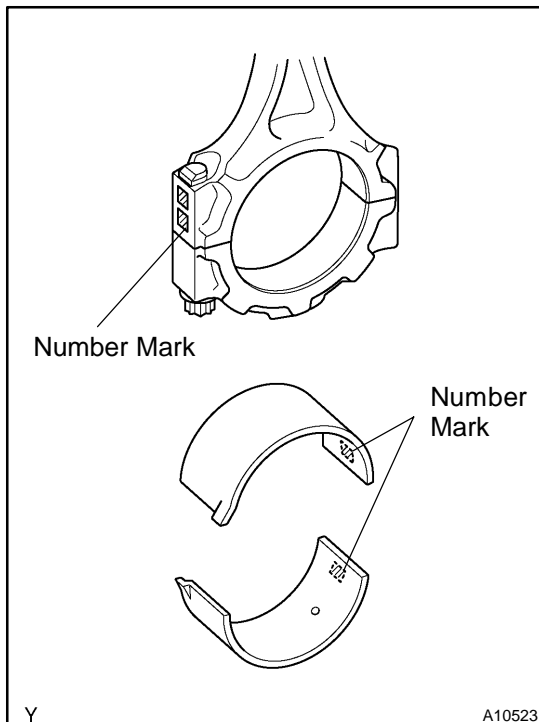

**HINT:**

If replacing a bearing, replace it with one having the same number as marked on the connecting rod. There are 4 sizes of standard bearings, marked "1", "2", "3" and "4" accordingly.

**Reference:**

**Standard bearing center wall thickness:**

Mark	mm (in.)
"1"	1.484 – 1.487 (0.0584 – 0.0585)
"2"	1.487 – 1.490 (0.0585 – 0.0587)
"3"	1.490 – 1.493 (0.0587 – 0.0588)
"4"	1.493 – 1.496 (0.0588 – 0.0589)

- (j) Completely remove the Plastigage.

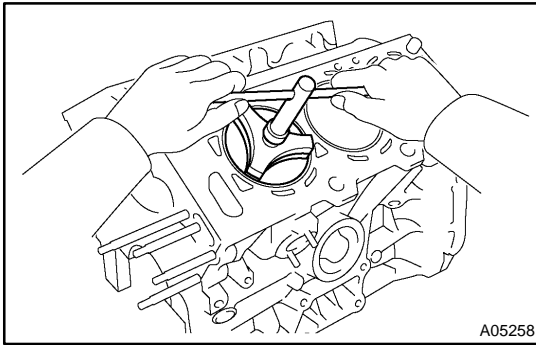

## 28. REMOVE PISTON AND CONNECTING ROD ASSEMBLIES

- Using a ridge reamer, remove all the carbon from the top of the cylinder.
- Push the piston, connecting rod assembly and upper bearing through the top of the cylinder block.

### HINT:

- Keep the bearings, connecting rod and cap together.
- Arrange the piston and connecting rod assemblies in the correct order.

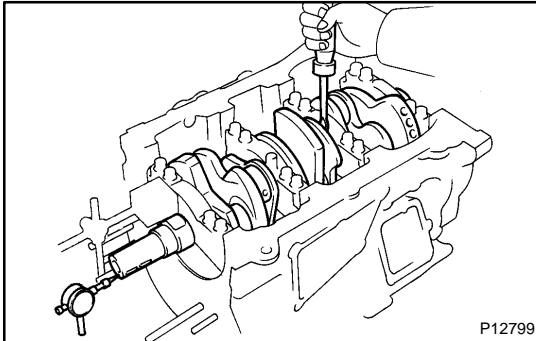

## 29. CHECK CRANKSHAFT THRUST CLEARANCE

Using a dial indicator, measure the thrust clearance while prying the crankshaft back and forth with a screwdriver.

### Standard thrust clearance:

**0.04 – 0.24 mm (0.0016 – 0.0095 in.)**

**Maximum thrust clearance: 0.30 mm (0.0118 in.)**

If the thrust clearance is greater than maximum, replace the thrust washers as a set.

### Thrust washer thickness:

**1.930 – 1.980 mm (0.0760 – 0.0780 in.)**

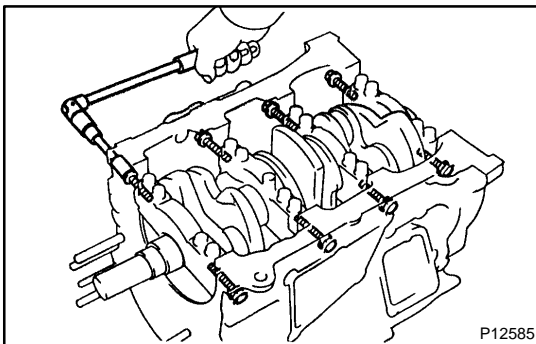

## 30. REMOVE MAIN BEARING CAPS AND CHECK OIL CLEARANCE

- Uniformly loosen and remove the 8 main bearing cap bolts and seal washers in the several passes and in the sequence shown.

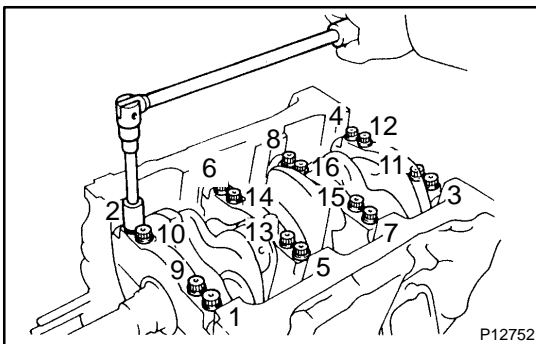

- Uniformly loosen and remove the 16 main bearing cap bolts in several passes and in the sequence shown.

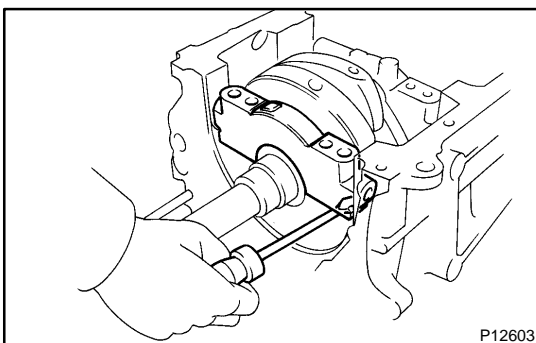

- Using a screwdriver, pry out main bearing caps. Remove the 4 main bearing caps, lower bearings and (No.2 main bearing cap only) 2 lower thrust washers.

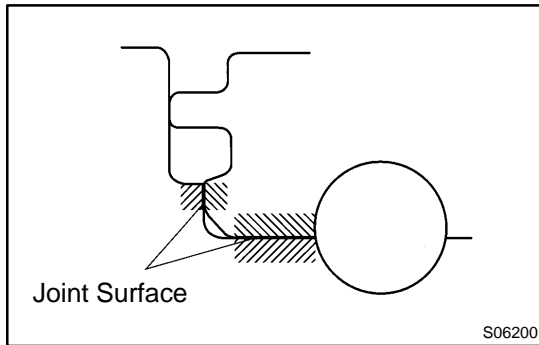
**NOTICE:**

**Pull up the main bearing cap little by little to the right and the left by turns and pay attention not to damage the joint surface of the cylinder block and the main bearing cap.**

**HINT:**

- Keep the lower bearing and main bearing cap together.
- Arrange the main bearing caps and lower thrust washers in correct order.

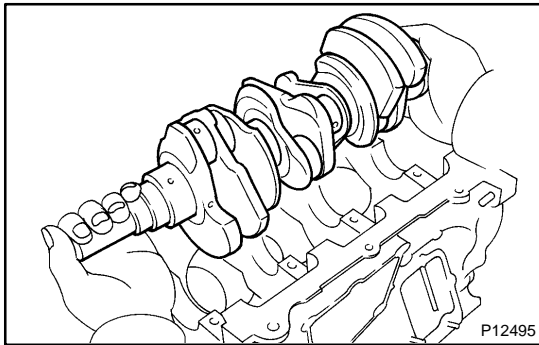

(d) Lift out the crankshaft.

**HINT:**

Keep the upper bearings together with the cylinder block.

- (e) Clean each main journal and bearing.  
 (f) Check each main journal and bearing for pitting and scratches.

If the journal or bearing is damaged, replace the bearings. If necessary, replace the crankshaft.

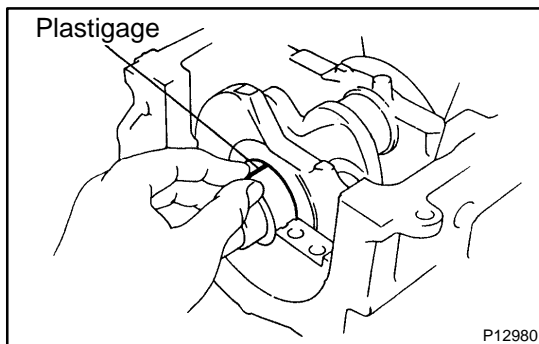

(g) Place the crankshaft on the cylinder block.

(h) Lay a strip of Plastigage across each journal.

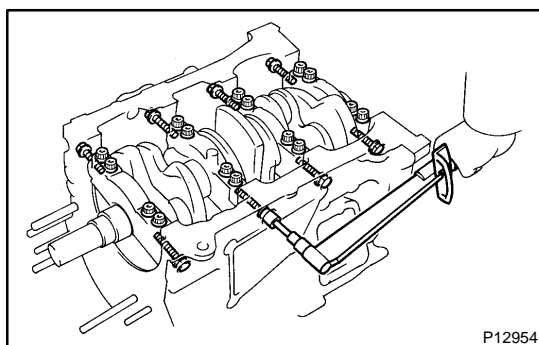

(i) Install the 4 main bearing caps (See page [EM-101](#)).

**Torque:****12 pointed head bolts:**

**1st: 22 N·m (225 kgf·cm, 16 ft·lbf)**

**2nd: Turn extra 90°**

**Hexagon head bolts:**

**27 N·m (275 kgf·cm, 20 ft·lbf)**

**NOTICE:**

**Do not turn the crankshaft.**

(j) Remove the main bearing caps. (See steps (a) to (c) )

(k) Measure the Plastigage at its widest point.

**Standard oil clearance:**

No.1 and No.4 journals	0.014 – 0.034 mm (0.0006 – 0.0013 in.)
No.2 and No.3 journals	0.026 – 0.046 mm (0.0010 – 0.0018 in.)

**Maximum clearance:**

No.1 and No.4 journals	0.05 mm (0.0020 in.)
No.2 and No.3 journals	0.06 mm (0.0024 in.)

If the oil clearance is greater than maximum, replace the bearings. If necessary, replace the crankshaft.

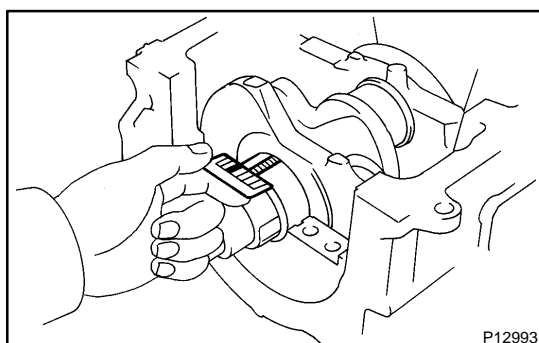

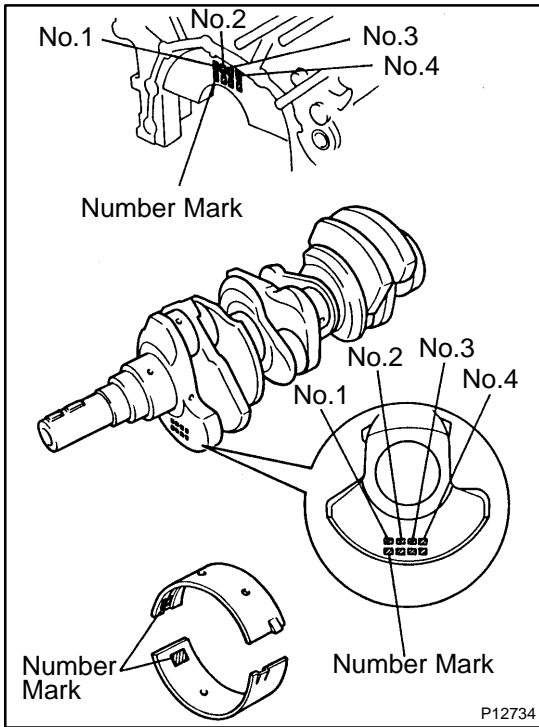

**HINT:**

If using a bearing, replace it with one having the same number. If the number of the bearing cannot be determined, select the correct bearing by adding together the numbers imprinted on the cylinder block and crankshaft, then refer to the table below for the appropriate bearing number. The No.1 and No.4 journal bearings have 5 standard bearing sizes, marked "3", "4", "5", "6" and "7" accordingly. The No.2 and No.3 journal bearings have 5 standard bearing sizes, marked "1", "2", "3", "4" and "5" accordingly.

**No.1 and No.4 journal bearings**

	Total number				
	": Number mark				
Cylinder block (A) + Crankshaft (B)	0 - 5	6 - 11	12 - 17	18 - 23	24 - 28
Use bearing	"3"	"4"	"5"	"6"	"7"

EXAMPLE: Cylinder block "06" (A)  
+ Crankshaft "08" (B)  
= Total number 14 (Use bearing "5")

**No.1 and No.4 journal standard bearings selection chart**

Crankshaft number mark	Cylinder block number mark																
	00	01	02	03	04	05	06	07	08	09	10	11	12	13	14	15	16
00	3	3	3	3	3	3	4	4	4	4	4	4	5	5	5	5	5
01	3	3	3	3	3	4	4	4	4	4	4	5	5	5	5	5	5
02	3	3	3	3	4	4	4	4	4	4	5	5	5	5	5	5	6
03	3	3	3	4	4	4	4	4	4	5	5	5	5	5	5	6	6
04	3	3	4	4	4	4	4	4	5	5	5	5	5	5	6	6	6
05	3	4	4	4	4	4	4	5	5	5	5	5	5	6	6	6	6
06	4	4	4	4	4	4	5	5	5	5	5	5	6	6	6	6	6
07	4	4	4	4	4	5	5	5	5	5	5	6	6	6	6	6	6
08	4	4	4	4	5	5	5	5	5	5	6	6	6	6	6	6	7
09	4	4	4	5	5	5	5	5	5	6	6	6	6	6	6	7	7
10	4	4	5	5	5	5	5	5	6	6	6	6	6	6	7	7	7
11	4	5	5	5	5	5	5	6	6	6	6	6	6	7	7	7	7
12	5	5	5	5	5	5	6	6	6	6	6	6	7	7	7	7	7

EXAMPLE: Cylinder block "06", Crankshaft "08"  
= Use bearing "5"

**No.2 and No.3 journal bearings**

	Total number					": Number mark
	0 – 5	6 – 11	12 – 17	18 – 23	24 – 28	
Cylinder block (A) + Crankshaft (B)	0 – 5	6 – 11	12 – 17	18 – 23	24 – 28	
Use bearing	"1"	"2"	"3"	"4"	"5"	

EXAMPLE: Cylinder block "06" (A)  
+ Crankshaft "08" (B)  
= Total number 14 (Use bearing "3")

**No.2 and No.3 journal standard bearings selection chart**

Crankshaft number mark	Cylinder block number mark																
	00	01	02	03	04	05	06	07	08	09	10	11	12	13	14	15	16
00	1	1	1	1	1	1	2	2	2	2	2	2	3	3	3	3	3
01	1	1	1	1	1	2	2	2	2	2	2	3	3	3	3	3	3
02	1	1	1	1	2	2	2	2	2	2	3	3	3	3	3	3	4
03	1	1	1	2	2	2	2	2	2	3	3	3	3	3	3	4	4
04	1	1	2	2	2	2	2	2	3	3	3	3	3	3	4	4	4
05	1	2	2	2	2	2	2	3	3	3	3	3	3	4	4	4	4
06	2	2	2	2	2	2	3	3	3	3	3	3	4	4	4	4	4
07	2	2	2	2	2	3	3	3	3	3	3	4	4	4	4	4	4
08	2	2	2	2	3	3	3	3	3	3	4	4	4	4	4	4	5
09	2	2	2	3	3	3	3	3	3	4	4	4	4	4	4	5	5
10	2	2	3	3	3	3	3	3	4	4	4	4	4	4	5	5	5
11	2	3	3	3	3	3	3	4	4	4	4	4	4	5	5	5	5
12	3	3	3	3	3	3	4	4	4	4	4	4	5	5	5	5	5

EXAMPLE: Cylinder block "06", Crankshaft "08"  
= Use bearing "3"

**Reference**

Item	Mark	mm (in.)
Cylinder block main journal bore diameter (A)	"00"	66.000 (2.5984)
	"01"	66.001 (2.5985)
	"02"	66.002 (2.5985)
	"03"	66.003 (2.5985)
	"04"	66.004 (2.5986)
	"05"	66.005 (2.5986)
	"06"	66.006 (2.5987)
	"07"	66.007 (2.5987)
	"08"	66.008 (2.5987)
	"09"	66.009 (2.5988)
	"10"	66.010 (2.5988)
	"11"	66.011 (2.5989)
	"12"	66.012 (2.5989)
	"13"	66.013 (2.5989)
	"14"	66.014 (2.5990)
	"15"	66.015 (2.5990)
"16"	66.016 (2.5990)	
Crankshaft main journal diameter (B)	"00"	61.000 (2.4016)
	"01"	60.999 (2.4015)
	"02"	60.998 (2.4015)
	"03"	60.997 (2.4015)
	"04"	60.996 (2.4014)
	"05"	60.995 (2.4014)
	"06"	60.994 (2.4013)
	"07"	60.993 (2.4012)
	"08"	60.992 (2.4012)
	"09"	60.991 (2.4012)
	"10"	60.990 (2.4012)
	"11"	60.989 (2.4011)
"12"	60.988 (2.4011)	
Standard bearing center wall thickness	"1"	2.486 – 2.489 (0.0979 – 0.0980)
	"2"	2.489 – 2.492 (0.0980 – 0.0981)
	"3"	2.492 – 2.495 (0.0981 – 0.0982)
	"4"	2.495 – 2.498 (0.0982 – 0.0983)
	"5"	2.498 – 2.501 (0.0983 – 0.0985)
	"6"	2.501 – 2.504 (0.0985 – 0.0986)
	"7"	2.504 – 2.507 (0.0986 – 0.0987)

(l) Completely remove the Plastigage.

**31. REMOVE CRANKSHAFT**

- (a) Lift out the crankshaft.
- (b) Remove the 4 upper main bearings and 2 upper thrust washers from the cylinder block.

**HINT:**

Arrange the main bearing caps, bearings and thrust washers in the correct order.

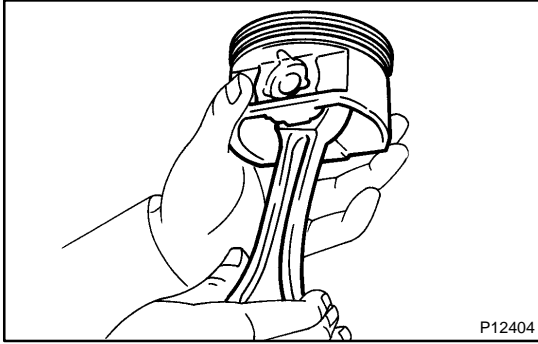
**32. CHECK FIT BETWEEN PISTON AND PISTON PIN**

Try to move the piston back and forth on the piston pin.  
If any movement is felt, replace the piston and pin as a set.

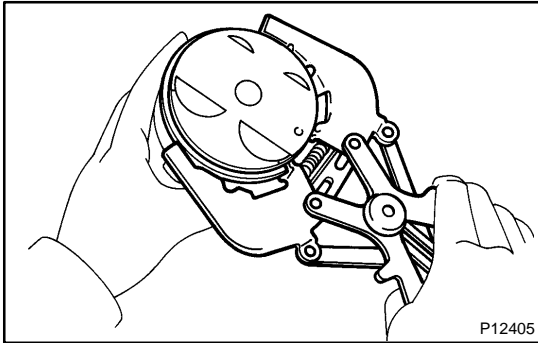
**33. REMOVE PISTON RINGS**

(a) Using a piston ring expander, remove the 2 compression rings.

(b) Remove the 2 side rails and oil ring by hand.

**HINT:**

Arrange the piston rings in the correct order only.

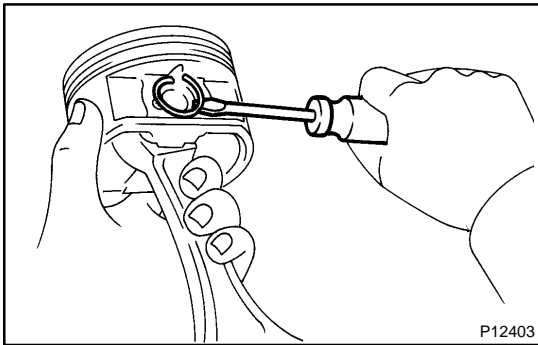
**34. DISCONNECT CONNECTING ROD FROM PISTON**

(a) Using a small screwdriver, pry out the 2 snap rings.

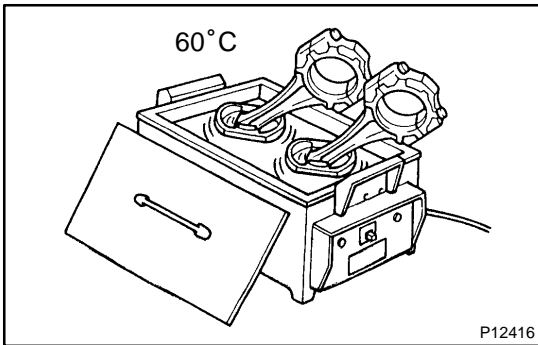

(b) Gradually heat the piston to approx. 60°C (140°F).

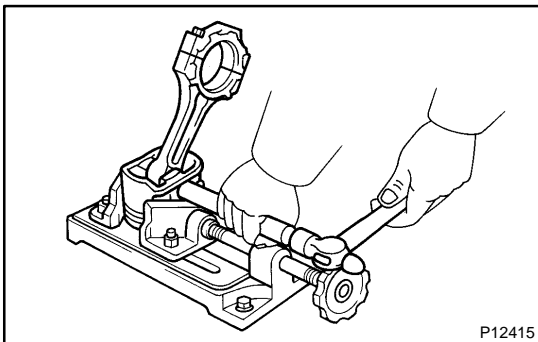

(c) Using a plastic-faced hammer and brass bar, lightly tap out the piston pin and remove the connecting rod.

**HINT:**

- The piston and pin are a matched set.
- Arrange the pistons, pins, rings, connecting rods and bearings in the correct order.

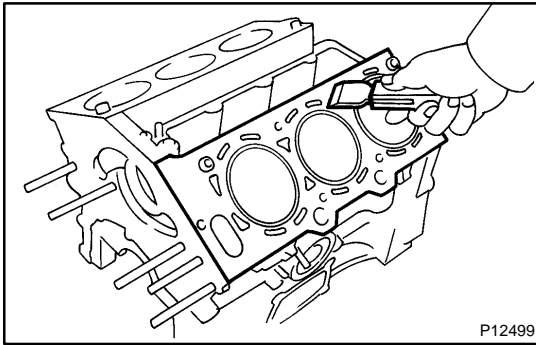

P12499

## INSPECTION

### 1. REMOVE GASKET MATERIAL

Using a gasket scraper, remove all the gasket material from the top surface of the cylinder block.

### 2. CLEAN CYLINDER BLOCK

Using a soft brush and solvent, thoroughly clean the cylinder block.

#### NOTICE:

If the cylinder is washed at high temperatures, the cylinder liner sticks out beyond the cylinder block, so always wash the cylinder block at a temperature of 45°C (113°F) or less.

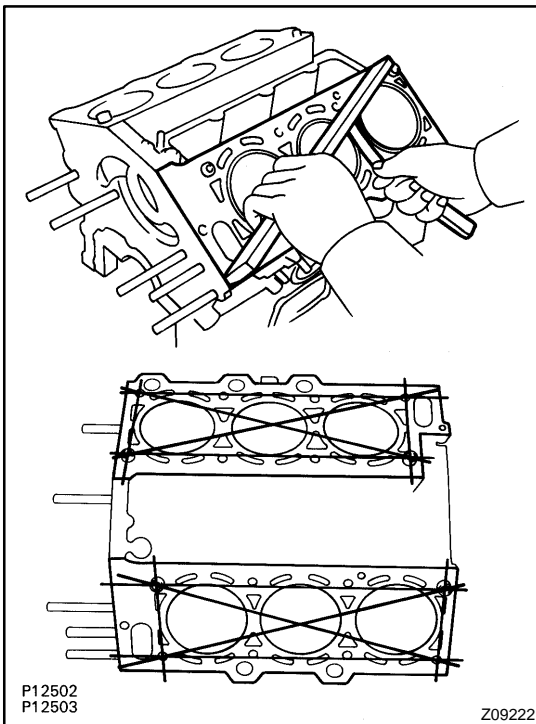
P12502  
P12503

Z09222

### 3. INSPECT TOP SURFACE OF CYLINDER BLOCK FOR FLATNESS

Using a precision straight edge and feeler gauge, measure the surface contacting the cylinder head gasket for warpage.

**Maximum warpage: 0.07 mm (0.0028 in.)**

If warpage is greater than maximum, replace the cylinder block.

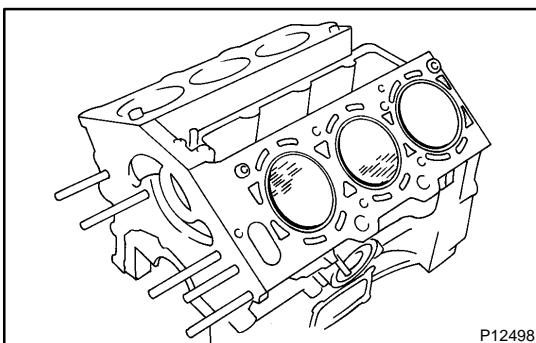

P12498

### 4. INSPECT CYLINDER FOR VERTICAL SCRATCHES

Visually check the cylinder for vertical scratches.

If deep scratches are present, replace the cylinder block.

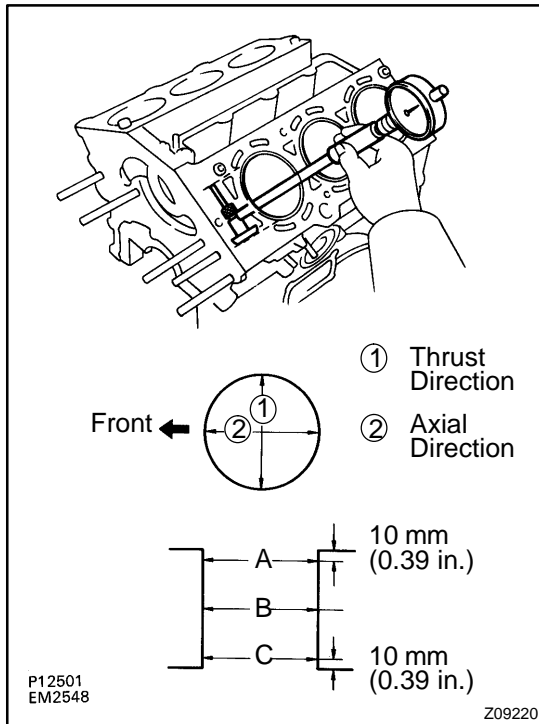

### 5. INSPECT CYLINDER BORE DIAMETER

Using a cylinder gauge, measure the cylinder bore diameter at positions A, B and C in the thrust and axial directions.

**Standard diameter:**

**87.500 – 87.512 mm (3.4449 – 3.4453 in.)**

**Maximum diameter: 87.52 mm (3.4457 in.)**

If the diameter is greater than maximum, replace the cylinder block.

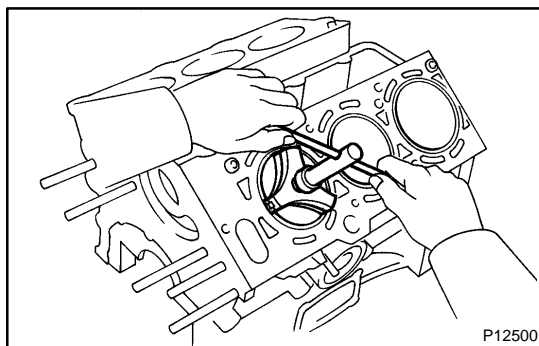

### 6. REMOVE CYLINDER RIDGE

If the wear is less than 0.2 mm (0.008 in.), using a ridge reamer, grind the top of the cylinder.

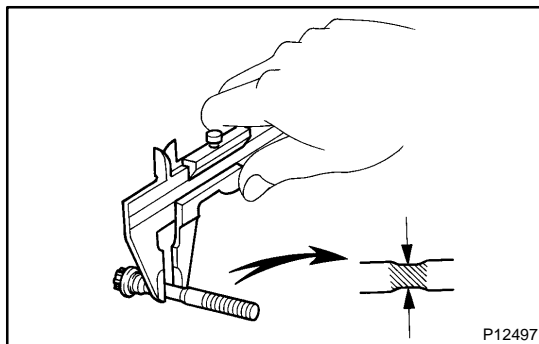

### 7. INSPECT 12 POINTED HEAD MAIN BEARING CAP BOLTS

Using vernier calipers, measure the tension portion diameter of the bolt.

**Standard diameter:**

**7.500 – 7.600 mm (0.2953 – 0.2992 in.)**

**Minimum diameter: 7.20 mm (0.2835 in.)**

If the diameter is less than minimum, replace the bolt.

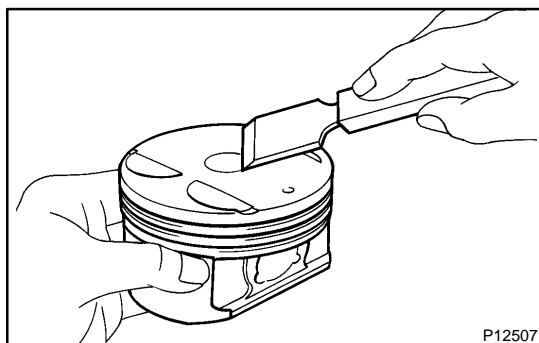

### 8. CLEAN PISTON

(a) Using a gasket scraper, remove the carbon from the piston top.

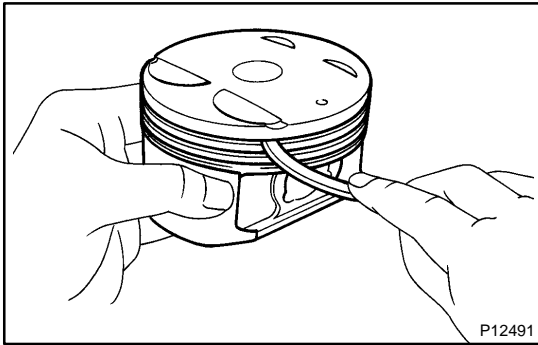

(b) Using a groove cleaning tool or broken ring, clean the piston ring grooves.

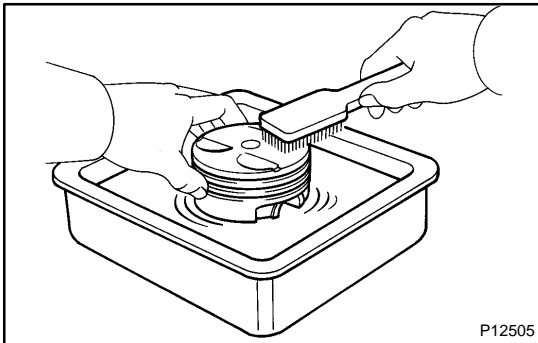

(c) Using solvent and a brush, thoroughly clean the piston.

**NOTICE:**

**Do not use a wire brush.**

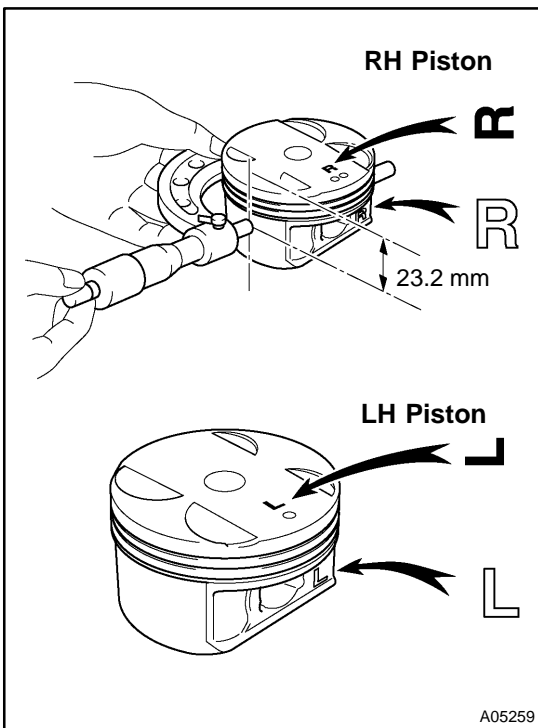

**9. INSPECT PISTON OIL CLEARANCE**

(a) Using a micrometer, measure the piston diameter at right angles to the piston pin center line, 23.2 mm (0.913 in.) from the piston head.

**Piston diameter:**

**87.406 – 87.416 mm (3.4412 – 3.4416 in.)**

(b) Measure the cylinder bore diameter in the thrust directions (See step 5.).

(c) Subtract the piston diameter measurement from the cylinder bore diameter measurement.

**Standard oil clearance:**

**0.084 – 0.106 mm (0.0033 – 0.0042 in.)**

**Maximum oil clearance: 0.13 mm (0.0051 in.)**

If the oil clearance is greater than maximum, replace all the 6 pistons. If necessary, replace the cylinder block.

**HINT:**

The shape of the piston varies for the RH and LH banks. The RH piston is marked with "R", the LH piston with "L".

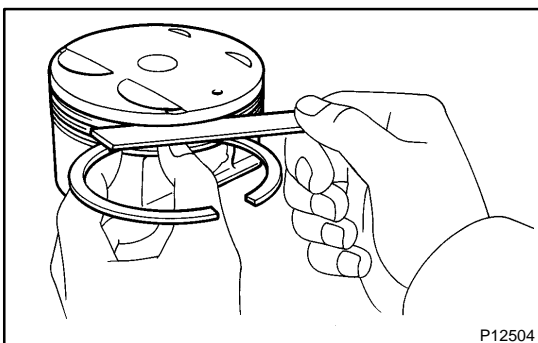

**10. INSPECT PISTON RING GROOVE CLEARANCE**

Using a feeler gauge, measure the clearance between new piston right and the wall of the ring groove.

**Ring groove clearance:**

No.1	0.020 – 0.070 mm (0.0008 – 0.0028 in.)
No.2	0.020 – 0.060 mm (0.0008 – 0.0024 in.)

If the clearance is not as specified, replace the piston.

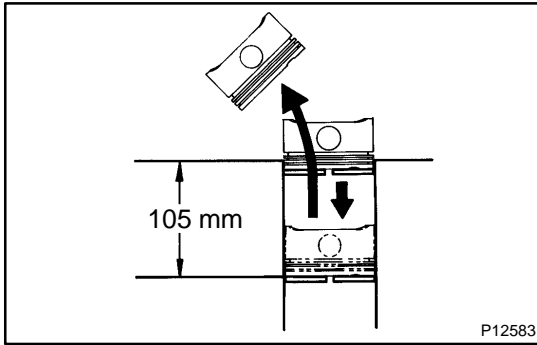
**11. INSPECT PISTON RING END GAP**

- (a) Insert the piston ring into the cylinder bore.
- (b) Using a piston, push the piston ring a little beyond the bottom of the ring travel, 105 mm (4.13 in.) from the top of the cylinder block.

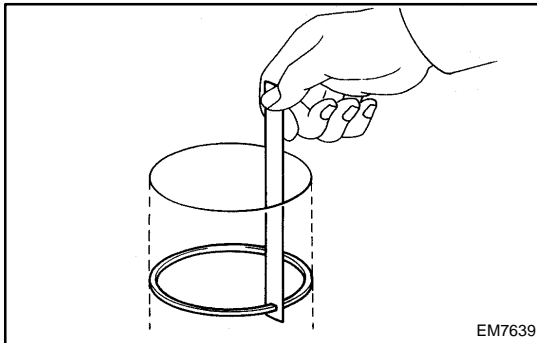

- (c) Using a feeler gauge, measure the end gap.

**Standard end gap:**

No.1	0.25 – 0.35 mm (0.0098 – 0.0138 in.)
No.2	0.35 – 0.45 mm (0.0138 – 0.0177 in.)
Oil (Side rail)	0.15 – 0.40 mm (0.0059 – 0.0157 in.)

**Maximum end gap:**

No.1	0.95 mm (0.0374 in.)
No.2	1.05 mm (0.0413 in.)
Oil (Side rail)	1.00 mm (0.0394 in.)

If the end gap is greater than maximum, replace the piston ring.  
If the end gap is greater than maximum, even with a new piston ring, replace the cylinder block.

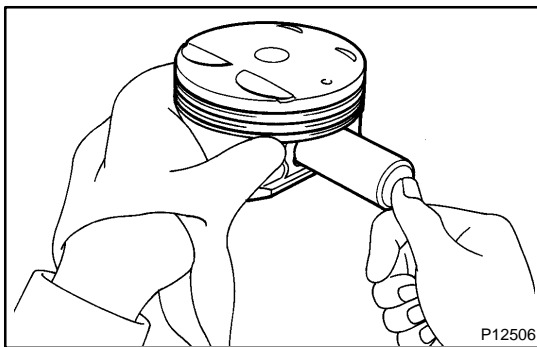
**12. INSPECT PISTON PIN FIT**

At 60°C (140°F), you should be able to push the piston pin into the piston pin hole with your thumb.

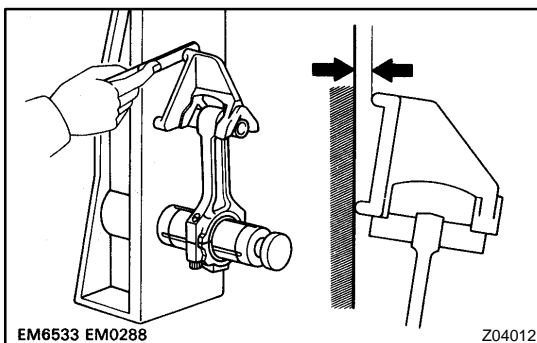
**13. INSPECT CONNECTING ROD ALIGNMENT**

Using a rod aligner and feeler gauge, check the connecting rod alignment.

- Check for out-of-alignment.

**Maximum out-of-alignment:**

**0.05 mm (0.0020 in.) per 100 mm (3.94 in.)**

If bend is greater than maximum, replace the connecting rod assembly.

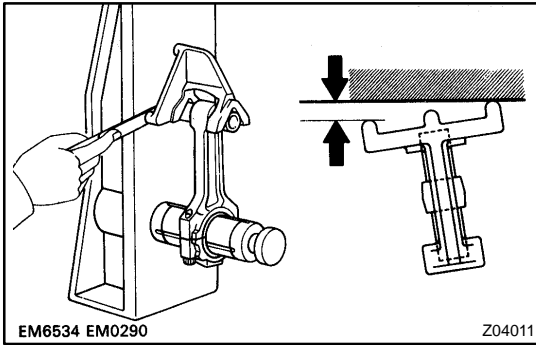

EM6534 EM0290

Z04011

- Check for twist

**Maximum twist:**

**0.15 mm (0.0059 in.) per 100 mm (3.94 in.)**

If twist is greater than maximum, replace the connecting rod assembly.

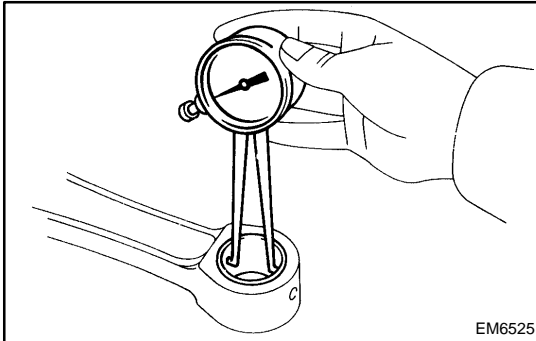

EM6525

#### 14. INSPECT PISTON PIN OIL CLEARANCE

- (a) Using a caliper gauge, measure the inside diameter of the connecting rod bushing.

**Bushing inside diameter:**

**22.005 – 22.014 mm (0.8663 – 0.8667 in.)**

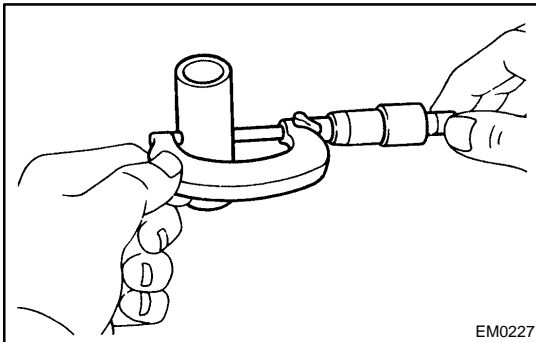

EM0227

- (b) Using a micrometer, measure the piston pin diameter.

**Piston pin diameter:**

**21.997 – 22.006 mm (0.8660 – 0.8664 in.)**

- (c) Subtract the piston pin diameter measurement from the bushing inside diameter measurement.

**Standard oil clearance:**

**0.005 – 0.011 mm (0.0002 – 0.0004 in.)**

**Maximum oil clearance: 0.05 mm (0.0020 in.)**

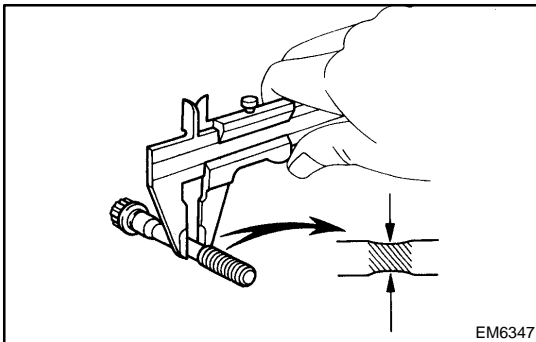

EM6347

#### 15. INSPECT CONNECTING ROD BOLTS

Using vernier calipers, measure the tension portion diameter of the bolt.

**Standard diameter: 7.2 – 7.3 mm (0.284 – 0.287 in.)**

**Minimum diameter: 7.0 mm (0.276 in.)**

If the diameter is less than minimum, replace the bolt.

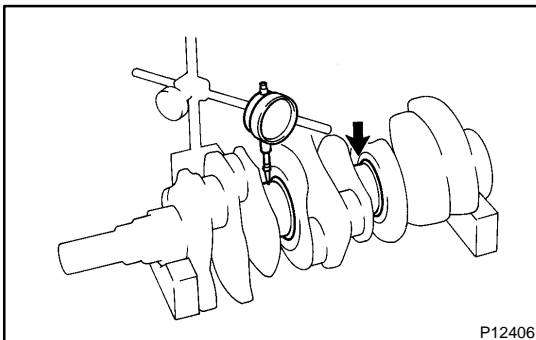

P12406

#### 16. INSPECT CRANKSHAFT FOR CIRCLE RUNOUT

- (a) Place the crankshaft on V-blocks.

- (b) Using a dial indicator, measure the circle runout, as shown in the illustration.

**Maximum circle runout: 0.06 mm (0.0024 in.)**

If the circle runout is greater than maximum, replace the crankshaft.

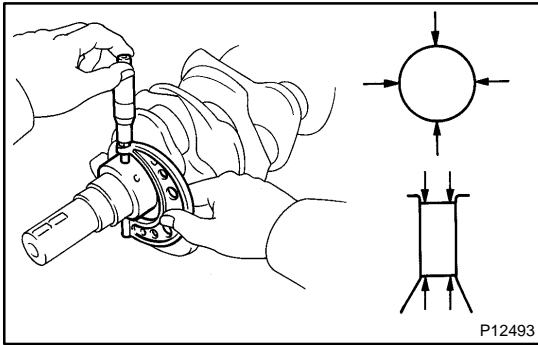
**17. INSPECT MAIN JOURNALS AND CRANK PINS**

- (a) Using a micrometer, measure the diameter of each main journal and crank pin.

**Main journal diameter:**

**60.988 – 61.000 mm (2.4011 – 2.4016 in.)**

**Crank pin diameter:**

**52.992 – 53.000 mm (2.0862 – 2.0866 in.)**

If the diameter is not as specified, check the oil clearance (See page [EM-83](#)).

If necessary, replace the crankshaft.

- (b) Check each main journal and crank pin for taper and out-of-round as shown.

**Maximum taper and out-of-round:**

**0.02 mm (0.0008 in.)**

If the taper and out-of-round is greater than maximum, replace the crankshaft.

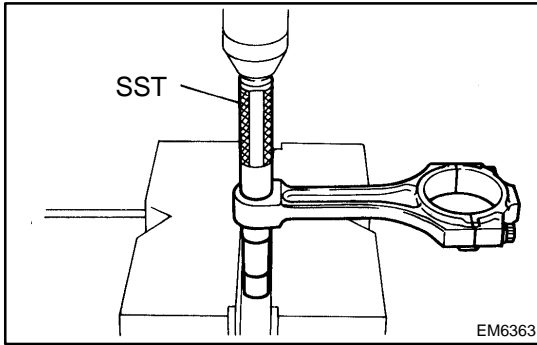

## REPLACEMENT

### 1. REPLACE CONNECTING ROD BUSHING

- (a) Using SST and a press, press out the bushing.  
SST 09222-30010

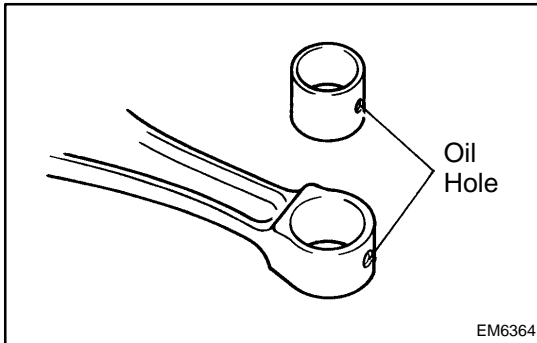

- (b) Align the oil holes of a new bushing and the connecting rod.

- (c) Using SST and a press, press in the bushing.  
SST 09222-30010

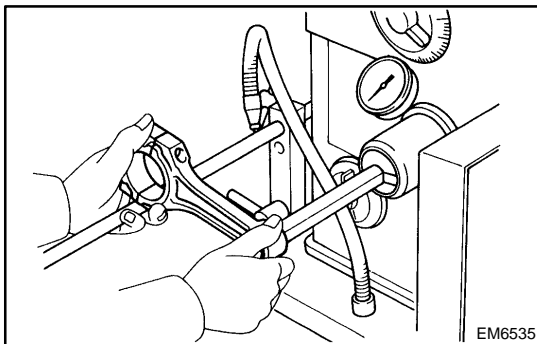

- (d) Using a pin hole grinder, hone the bushing to obtain the standard specified clearance (See page EM-93) between the bushing and piston pin.

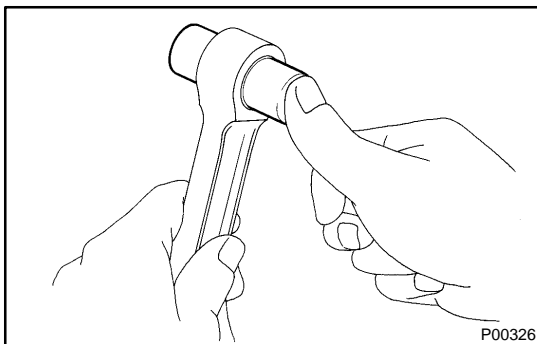

- (e) Check the piston pin fit at normal room temperature. Coat the piston pin with engine oil, and push it into the connecting rod with your thumb.

### 2. REPLACE CRANKSHAFT FRONT OIL SEAL (See page LU-14)

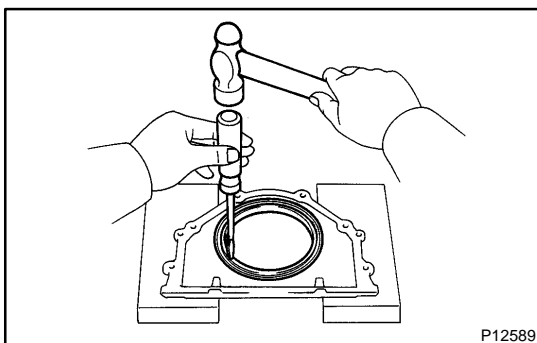

### 3. REPLACE CRANKSHAFT REAR OIL SEAL

#### HINT:

There are 2 methods ((a) and (b)) to replace the oil seal which are as follows:

- (a) If the rear oil seal retainer is removed from the cylinder block.
- (1) Using a screwdriver and hammer, tap out the oil seal.

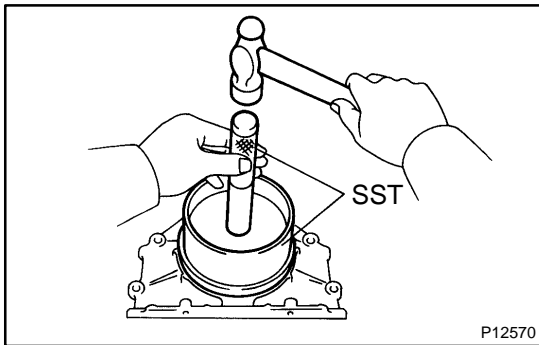

- (2) Using SST and a hammer, tap in a new oil seal until its surface is flush with the rear oil seal retainer edge.

SST 09223-15030, 09950-70010 (09951-07100)

- (3) Apply MP grease to the oil seal lip.

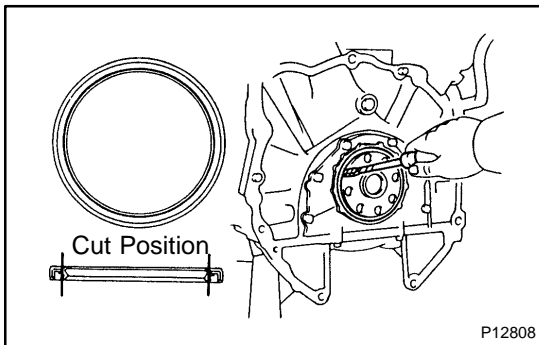

- (b) If the rear oil seal retainer is installed to the cylinder block.

- (1) Using a knife, cut off the oil seal lip.

- (2) Using a screwdriver, pry out the oil seal.

**NOTICE:**

**Be careful not to damage the crankshaft. Tape the screwdriver tip.**

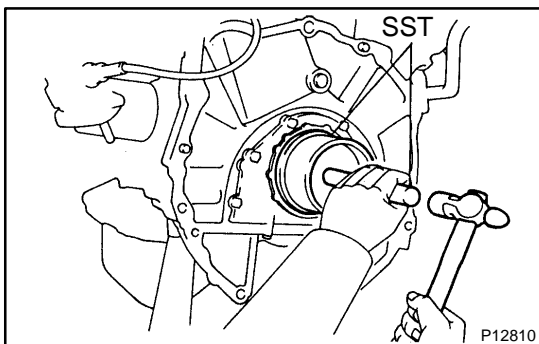

- (3) Apply MP grease to a new oil seal lip.

- (4) Using SST and a hammer, tap in the oil seal until its surface is flush with the rear oil seal retainer edge.

SST 09223-15030, 09950-70010 (09951-07100)

## REASSEMBLY

### HINT:

- Thoroughly clean all parts to be assembled.
- Before installing the parts, apply new engine oil to all sliding and rotating surfaces.
- Replace all gaskets, O-rings and oil seals with new parts.

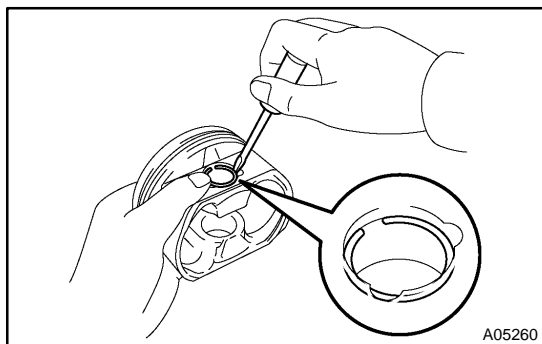

### 1. ASSEMBLE PISTON AND CONNECTING ROD

- (a) Using a small screwdriver, install a new snap ring at one end of the piston pin hole.

### HINT:

Be sure that end gap of the snap ring is not aligned with the pin hole cutout portion of the piston.

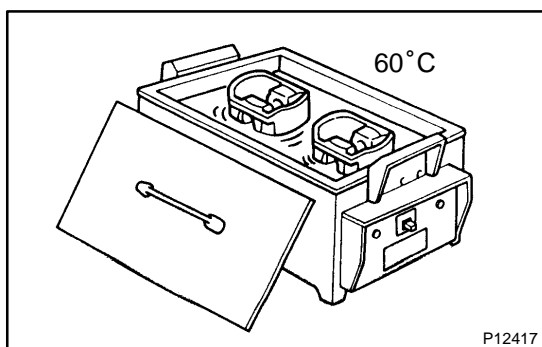

- (b) Gradually heat the piston to about 60°C (140°F).

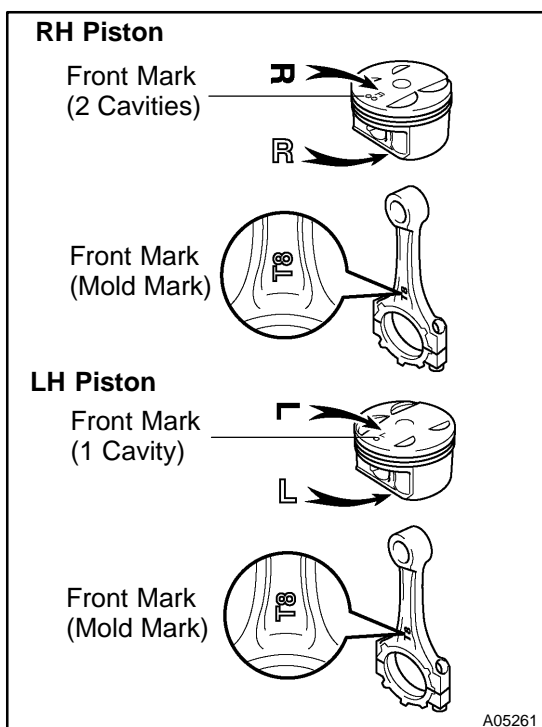

- (c) Coat the piston pin with engine oil.
- (d) Align the front marks of the piston and connecting rod, and push in the piston pin with your thumb.
- (e) Using a small screwdriver, install a new snap ring on the other end of the piston pin hole.

### HINT:

Be sure that end gap of the snap ring is not aligned with the pin hole cutout portion of the piston.

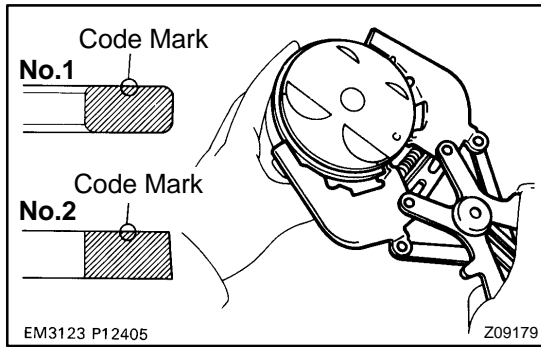

**2. INSTALL PISTON RINGS**

- (a) Install the oil ring expander and 2 side rails by hand.
- (b) Using a piston ring expander, install the 2 compression rings with the code mark facing upward.

**Code mark:**

No.1	1R or T
No.2	2R or 2T

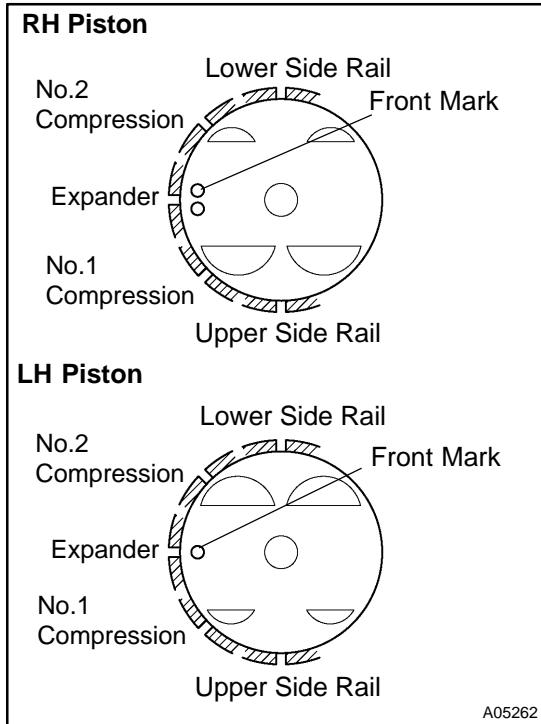

- (c) Position the piston rings so that the ring ends are as shown.

**NOTICE:**

**Do not align the ring ends.**

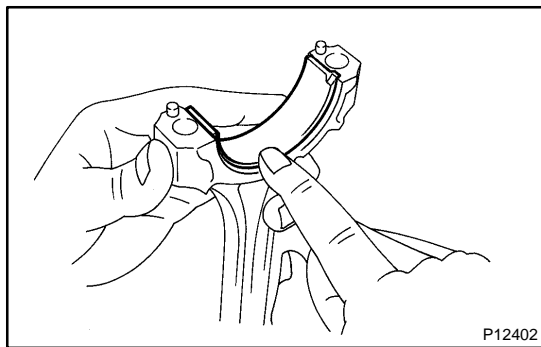

**3. INSTALL CONNECTING ROD BEARINGS**

- (a) Align the bearing claw with the groove of the connecting rod or connecting cap.
- (b) Install the bearings in the connecting rod and connecting rod cap.

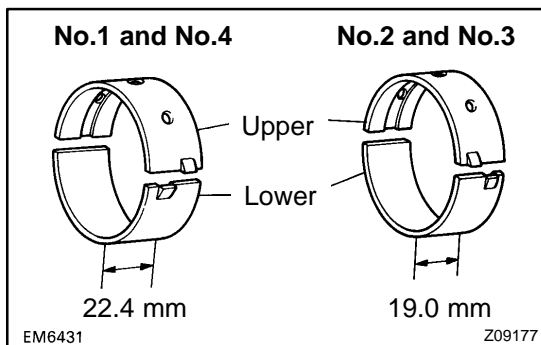

**4. INSTALL MAIN BEARINGS**

**HINT:**

- Main bearings come in widths of 19.0 mm (0.748 in.) and 22.4 mm (0.882 in.). Install the 22.4 mm (0.882 in.) bearings in the No.1 and No.4 cylinder block journal positions with the main bearing cap. Install the 19.0 mm (0.748 in.) bearings in the No.2 and No.3 positions.
- Upper bearings have an oil groove and oil holes; lower bearings do not.

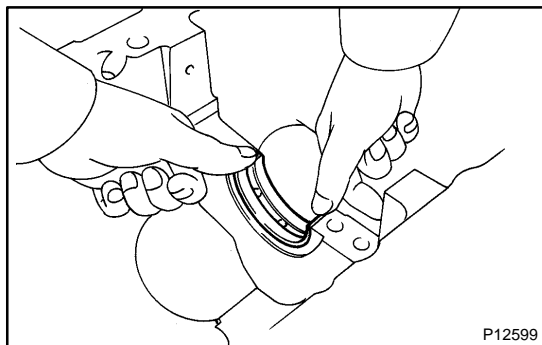

- (a) Align the bearing claw with the claw groove of the cylinder block, and push in the 4 upper bearings.

**NOTICE:**

Install the bearing with the oil hole in the cylinder block.

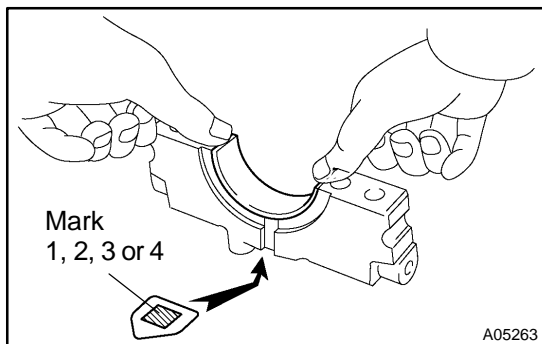

- (b) Align the bearing claw with the claw groove of the main bearing cap, and push in the 4 lower bearings.

**HINT:**

A number is marked on each main bearing cap to indicate the installation position.

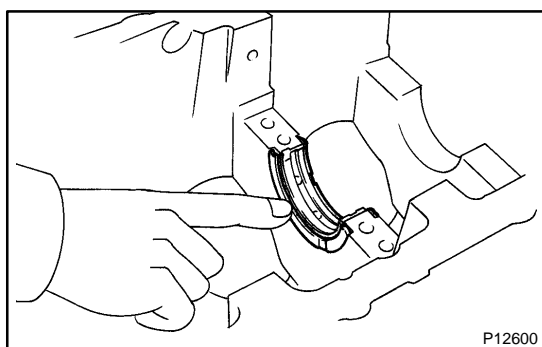
**5. INSTALL UPPER THRUST WASHERS**

Install the 2 thrust washers under the No.2 journal position of the cylinder block with the oil grooves facing outward.

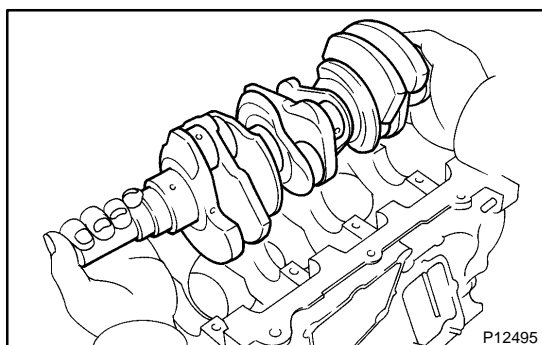
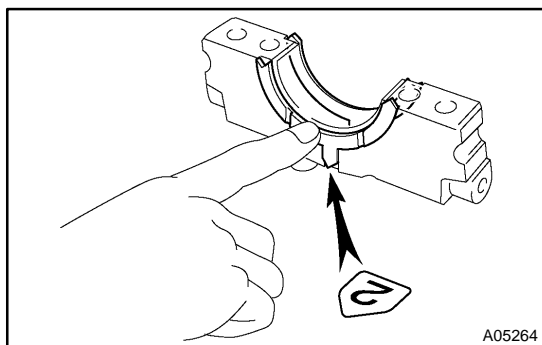
**6. PLACE CRANKSHAFT ON CYLINDER BLOCK****7. PLACE MAIN BEARING CAPS AND LOWER THRUST WASHERS ON CYLINDER BLOCK**

- (a) Install the 2 thrust washers on the No.2 bearing cap with the grooves facing outward.

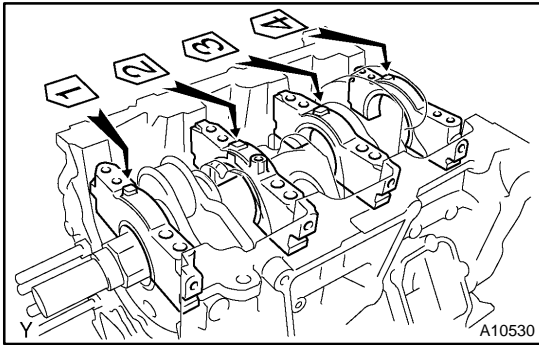

(b) Temporarily place the 4 main bearing caps level and let them in their proper locations.

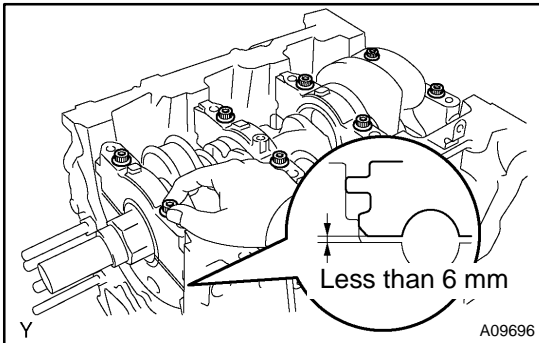

(c) Apply a light coat of engine oil on the threads and under the main bearing cap bolts for the 12 pointed head.  
 (d) Temporarily install the 8 main bearing cap bolts to the inside positions.  
 (e) Insert the main bearing cap with your hand until the clearance between the main bearing cap and the cylinder block will become less than 6 mm (0.23 in.) by making the 2 internal main bearing cap bolts as a guide.

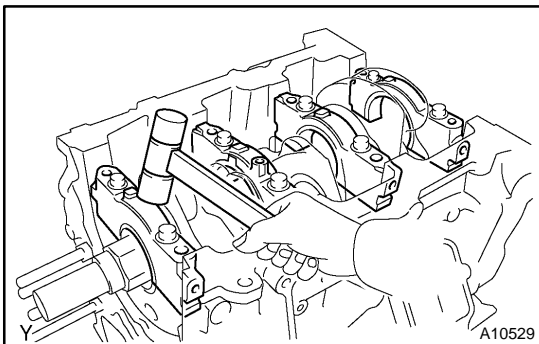

(f) Using a plastic-faced hammer, lightly tap the bearing cap to ensure a proper fit.

**8. INSTALL 12 POINTED HEAD MAIN BEARING CAP BOLTS**

**HINT:**

- The main bearing cap bolts are tightened in 2 progressive steps (steps (b) and (d)).
- If any of the main bearing cap bolts is broken or deformed, replace it.

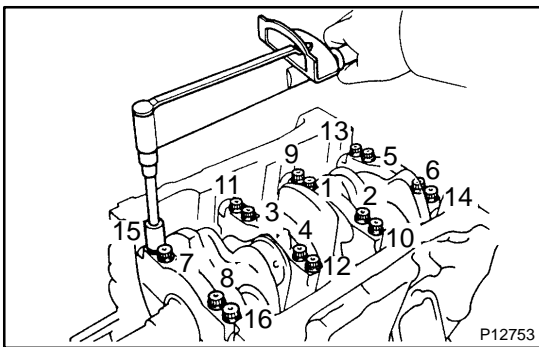

(a) Apply a light coat of engine oil on the threads and under the main bearing cap bolts.  
 (b) Install and uniformly tighten the 16 main bearing cap bolts in several passes and in the sequence shown.

**Torque: 22 N·m (225 kgf-cm, 16 ft-lbf)**

If any of the main bearing cap bolts does not meet the torque specification, replace the main bearing cap bolt.

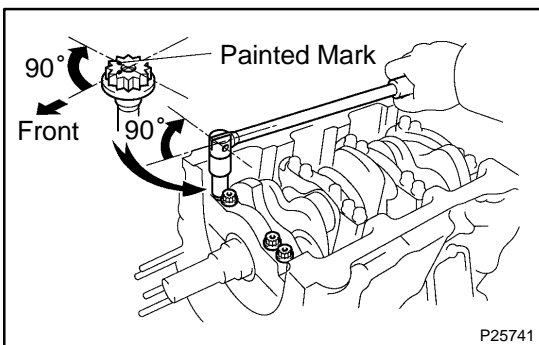

(c) Mark the front of the main bearing cap bolts with paint.  
 (d) Retighten the main bearing cap bolts by 90° in the numerical order shown.  
 (e) Check that the painted mark is now at a 90° angle to the front.

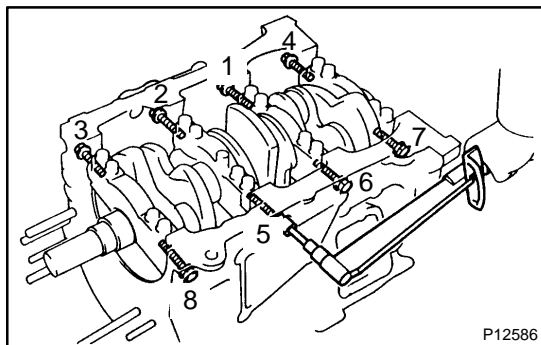

P12586

## 9. INSTALL HEXAGON HEAD MAIN BEARING CAP BOLTS

- Install a new seal washer to the main bearing cap bolt.
- Install and uniformly tighten the 8 main bearing cap bolts in several passes and in the sequence shown.

**Torque: 27 N·m (275 kgf·cm, 20 ft·lbf)**

## 10. CHECK CRANKSHAFT THRUST CLEARANCE (See page EM-83)

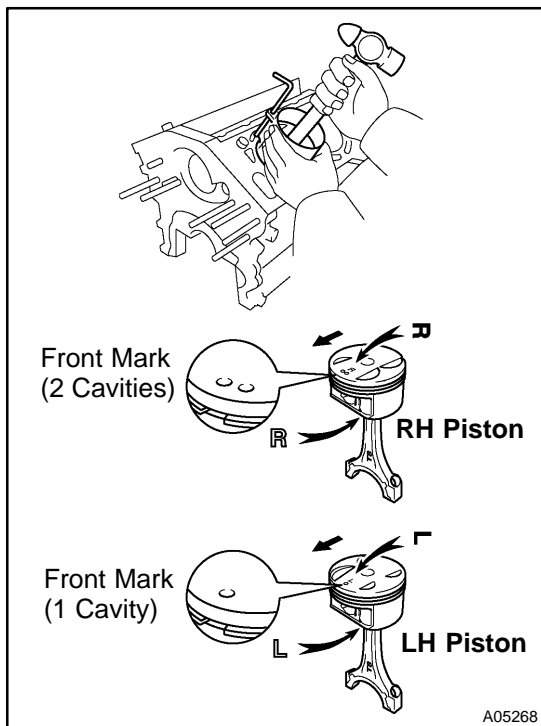

A05268

## 11. INSTALL PISTON AND CONNECTING ROD ASSEMBLES

Using a piston ring compressor, push the correctly numbered piston and connecting rod assemblies into each cylinder with the front mark of the piston facing forward.

**HINT:**

The shape of the piston varies for the RH and LH banks. The RH piston is marked with "R", the LH piston with "L".

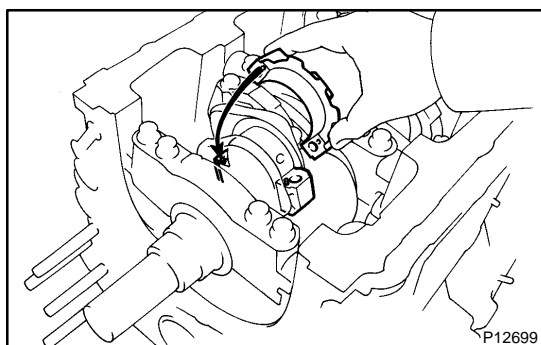

P12699

## 12. PLACE CONNECTING ROD CAP ON CONNECTING ROD

- Match the numbered connecting rod cap with the connecting rod.
- Align the pin dowels of the connecting rod cap with the pins of the connecting rod, and install the connecting rod.

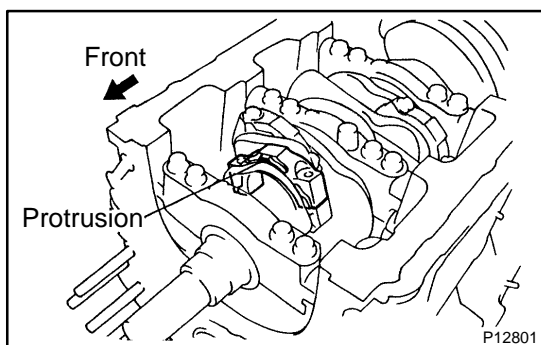

P12801

- Check that the protrusion of the connecting rod cap is facing in the correct direction.

## 13. INSTALL CONNECTING ROD CAP BOLTS

**HINT:**

- The connecting rod cap bolts are tightened in 2 progressive steps (steps (b) and (d)).
- If any of the connecting rod cap bolts is broken or deformed, replace it.

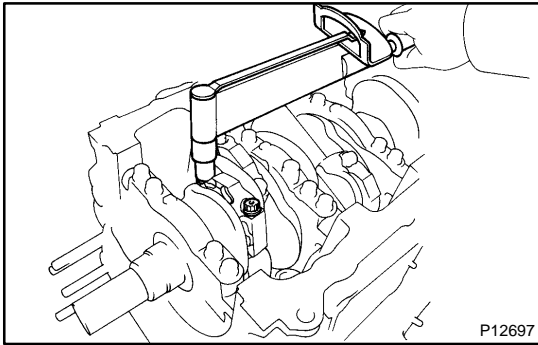

- (a) Apply a light coat of engine oil on the threads and under the heads of the connecting rod cap bolts.
- (b) Install and alternately tighten the 2 connecting rod cap bolts in several passes.

**Torque: 24.5 N·m (250 kgf·cm, 18 ft·lbf)**

If any of the connecting rod cap bolts does not meet the torque specification, replace the connecting rod cap bolts.

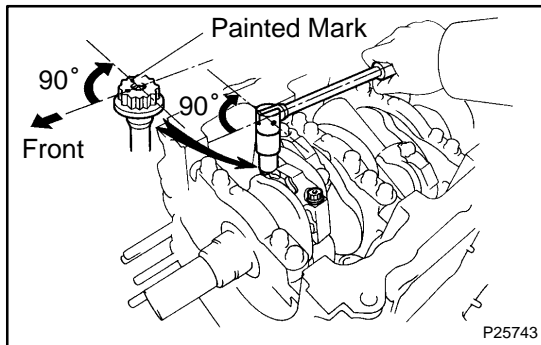

- (c) Mark the front of the connecting cap bolts with paint.
- (d) Retighten the cap bolts by 90° as shown.
- (e) Check that the painted mark is now at a 90° angle to the front.
- (f) Check that the crankshaft turns smoothly.

#### 14. CHECK CONNECTING ROD THRUST CLEARANCE (See page EM-83)

#### 15. INSTALL REAR OIL SEAL RETAINER

- (a) Remove any old packing (FIPG) material and be careful not to drop any oil on the contact surfaces of the oil seal retainer and cylinder block.
  - Using a razor blade and gasket scraper, remove all the oil packing (FIPG) material from the gasket surfaces and sealing grooves.
  - Thoroughly clean all components to remove all the loose material.
  - Using a non-residue solvent, clean both sealing surfaces.

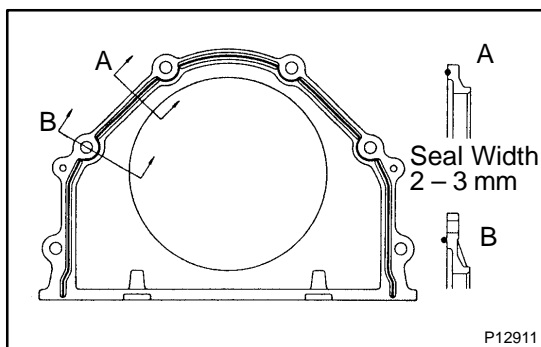

- (b) Apply seal packing to the oil seal retainer as shown in the illustration.

**Seal packing: Part No. 08826-00080 or equivalent**

- Install a nozzle that has been cut to a 2 – 3 mm (0.08 – 0.12 in.) opening.
- Parts must be assembled within 3 minutes of application. Otherwise the material must be removed and reapplied.
- Immediately remove nozzle from the tube and reinstall cap.

- (c) Install the oil seal retainer with the 6 bolts Uniformly tighten the bolt in several passes and in the sequence shown.

**Torque: 8 N·m (80 kgf·cm, 69 in.-lbf)**

#### 16. INSTALL CYLINDER BLOCK SIDE COVER

Install a new gasket and the cylinder block side cover with the 3 bolts and 2 nuts.

**Torque: 9 N·m (90 kgf·cm, 78 in.-lbf)**

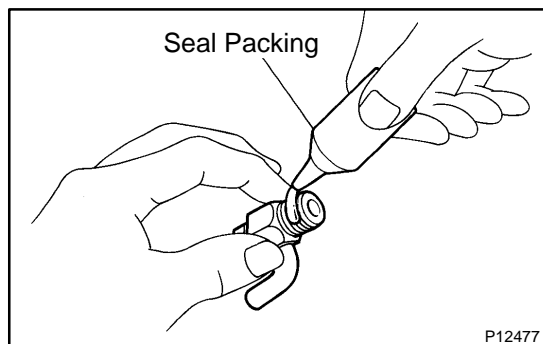
**17. INSTALL ENGINE COOLANT DRAIN UNION**

- (a) Apply seal packing to 2 or 3 threads.  
**Seal packing: Part No. 08826-00100 or equivalent**
- (b) Install the drain union.  
**Torque: 39 N·m (400 kgf·cm, 29 ft·lbf)**

**HINT:**

After applying the specified torque, rotate the drain union clockwise until its drain port is facing downward.

**18. INSTALL WATER SEAL PLATE**

- (a) Remove any old packing (FIPG) material and be careful not to drop any oil on the contact surfaces of the seal plate and cylinder block.
- Using a razor blade and gasket scraper, remove all the old packing (FIPG) material from the gasket surfaces and sealing groove.
  - Thoroughly clean all components to remove all the loose material.
  - Using a non-residue solvent, clean both sealing surfaces.

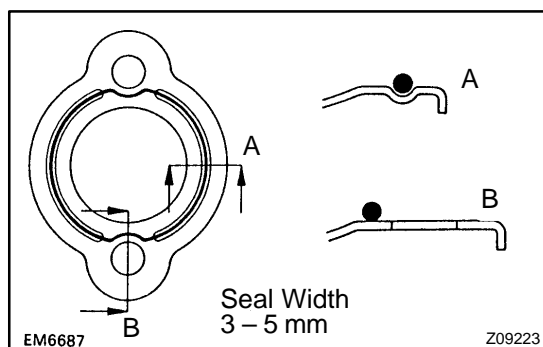

- (b) Apply seal packing to the seal plate as shown in the illustration.

**Seal packing: Part No. 08826-00100 or equivalent**

- Install a nozzle that has been cut to a 3 – 5 mm (0.12 – 0.20 in.) opening.
- Parts must be assembled within 3 minutes of application. Otherwise the material must be removed and reapplied.
- Immediately remove nozzle from the tube and reinstall cap.

- (c) Install the seal plate with the 2 nuts.

**Torque: 18 N·m (180 kgf·cm, 13 ft·lbf)**

**19. INSTALL OIL FILTER UNION**

**Torque: 30 N·m (310 kgf·cm, 22 ft·lbf)**

**20. INSTALL OIL FILTER (See page LU-3)****21. INSTALL OIL PUMP (See page LU-16)****22. INSTALL NO.1 OIL PAN (See page LU-16)****23. INSTALL OIL STRAINER (See page LU-16)****24. INSTALL NO.2 OIL PAN (See page LU-16)****25. INSTALL WATER PUMP (See page CO-8)****26. INSTALL WATER INLET HOUSING**

- (a) Remove any old packing (FIPG) material and be careful not to drop any oil on the contact surfaces of the water inlet housing and cylinder block.
- Using a razor blade and gasket scraper, remove all the old packing (FIPG) material from the gasket surfaces and sealing grooves.
  - Thoroughly clean all components to remove all the loose material.

- Using a non-residue solvent, clean both sealing surfaces.

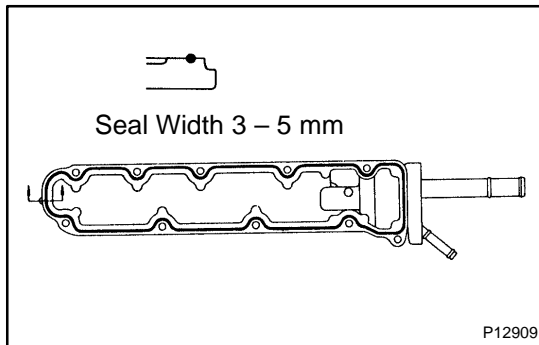

- (b) Apply seal packing to the water inlet housing as shown in the illustration.

**Seal packing: Part No. 08826-00100 or equivalent**

- Install a nozzle that has been cut to a 3 – 5 mm (0.12 – 0.20 in.) opening.

**HINT:**

Avoid applying an excessive amount to the surface.

- Parts must be assembled within 3 minutes of application. Otherwise the material must be removed and reapplied.
- Immediately remove nozzle from the tube and reinstall cap.

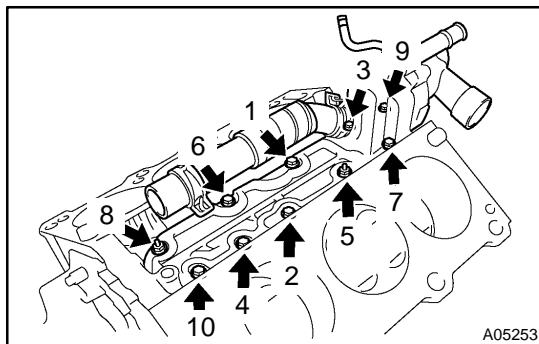

- (c) Install the water inlet housing with the 8 bolts and 2 nuts. Uniformly tighten the bolts and nuts in several passes and in the sequence shown.

**Torque: 8 N·m (80 kgf·cm, 69 in.-lbf)**

- (d) Connect the No.2 ECT switch connector.  
 (e) Connect the engine wire clamp to the water inlet.  
 (f) Install the engine wire band.  
 (g) Install the engine wire clamp.

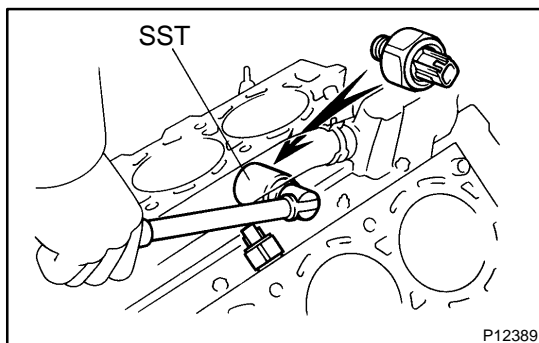

**27. INSTALL KNOCK SENSORS**

- (a) Using SST, install the 2 knock sensors.  
 SST 09816-30010

**Torque: 39 N·m (400 kgf·cm, 29 ft-lbf)**

- (b) Connect the 2 knock sensor connectors.

**28. INSTALL NO.2 IDLER PULLEY BRACKET**

**Torque: 28 N·m (290 kgf·cm, 21 ft-lbf)**

**29. INSTALL A/C COMPRESSOR HOUSING BRACKET**

**Torque: 25 N·m (250 kgf·cm, 18 ft-lbf)**

30. **INSTALL OIL PRESSURE SWITCH**  
(See page [LU-1](#))
31. **INSTALL GENERATOR, BRACKET AND ADJUSTING BAR ASSEMBLY**  
Torque: 43 N·m (440 kgf·cm, 32 ft·lbf)
32. **INSTALL ENGINE WIRE**
33. **CONNECT OIL LEVEL SENSOR CONNECTOR**
34. **CONNECT OIL PRESSURE SWITCH CONNECTOR**
35. **CONNECT CRANKSHAFT POSITION SWITCH CONNECTOR**
36. **INSTALL CYLINDER HEAD** (See page [EM-59](#))
37. **INSTALL TIMING PULLEYS AND BELT**  
(See page [EM-21](#))
38. **REMOVE ENGINE STAND**

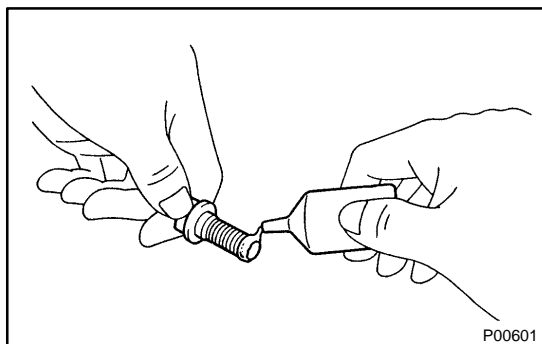

39. **INSTALL DRIVE PLATE**
  - (a) Apply adhesive to 2 or 3 threads of the bolt end.  
**Adhesive: Part No. 08833-00070, THREE BOND 1324 or equivalent**
  - (b) Install the front spacer, drive plate and rear plate on the crankshaft.

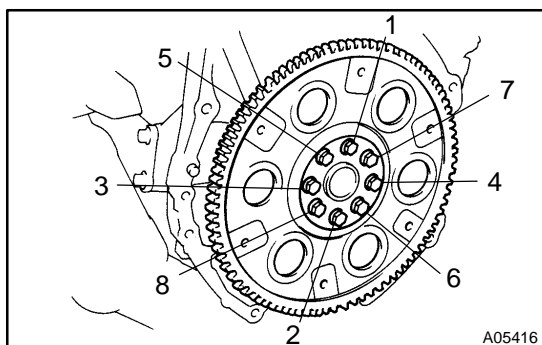

- (c) Install and uniformly tighten the 8 bolts in several passes and in the sequence shown.  
**Torque: 83 N·m (850 kgf·cm, 61 ft·lbf)**

# EXHAUST SYSTEM COMPONENTS

EM02R-05

## Heated Oxygen Sensor (Bank 1 Sensor 2)

**HINT:**

- Before installing the oxygen sensor, twist the sensor wire counterclockwise 3 and 1/2 turns.
- After installing the sensor wire is not twisted. If it is twisted, remove the oxygen sensor and reinstall it.

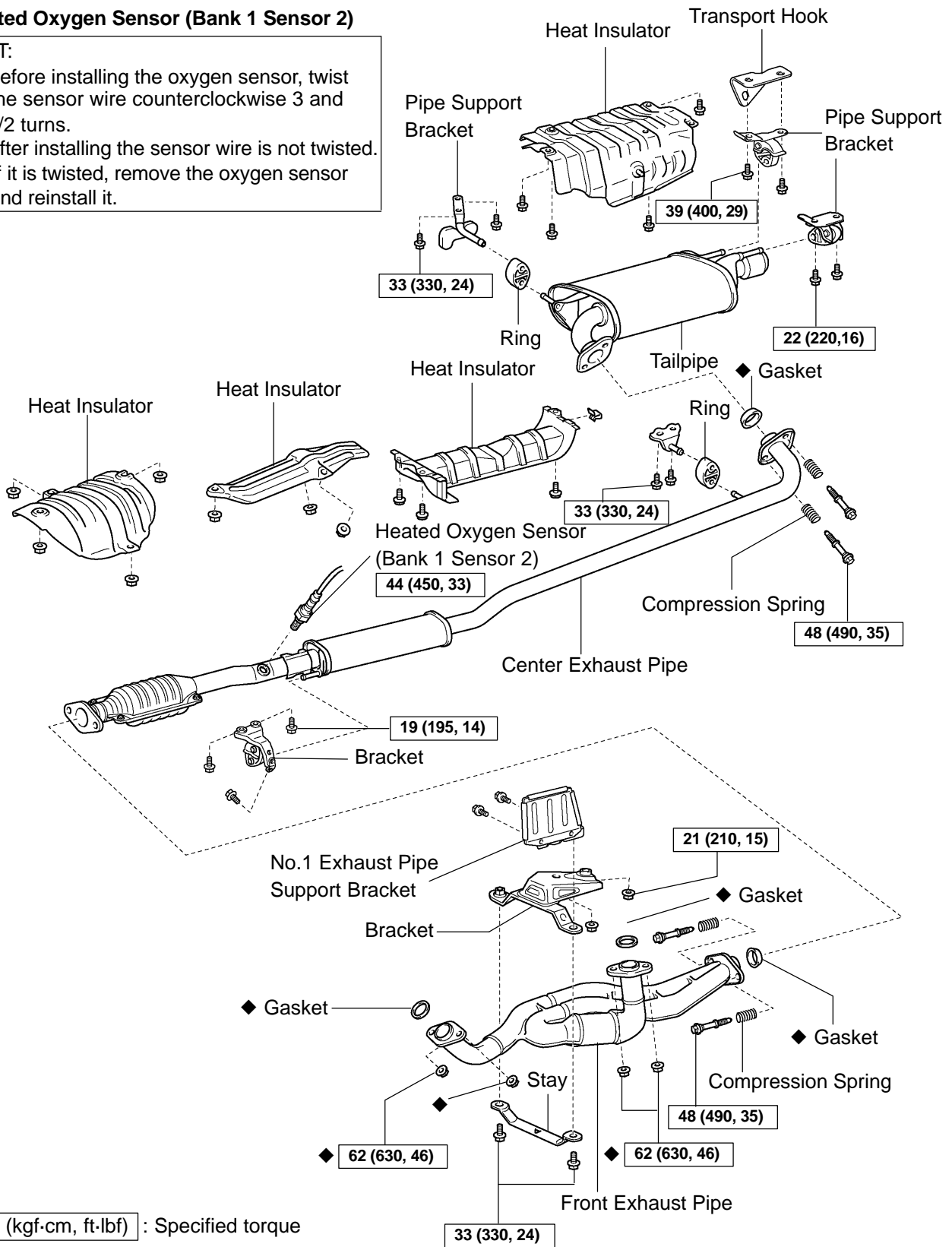

N·m (kgf·cm, ft·lbf) : Specified torque

◆ Non-reusable part

B13821