

<b>DTC</b>	<b>P1520/95</b>	<b>Stop Light Switch Signal Malfunction (Only for A/T)</b>
------------	-----------------	--

## CIRCUIT DESCRIPTION

This signal is used to detect when the brakes have been applied. The STP signal voltage is the same as the voltage supplied to the stop lights.

The STP signal is used mainly to control the fuel cut-off engine speed (The fuel cut-off engine speed is reduced slightly when the vehicle is braking.).

DTC No.	DTC Detecting Condition	Trouble Area
P1520/95	The stop light switch does not turn off even once the vehicle is driven (2 trip detection logic)	<ul style="list-style-type: none"> <li>• Short in stop light switch signal circuit</li> <li>• Stop light switch</li> <li>• Engine ECU</li> </ul>

## WIRING DIAGRAM

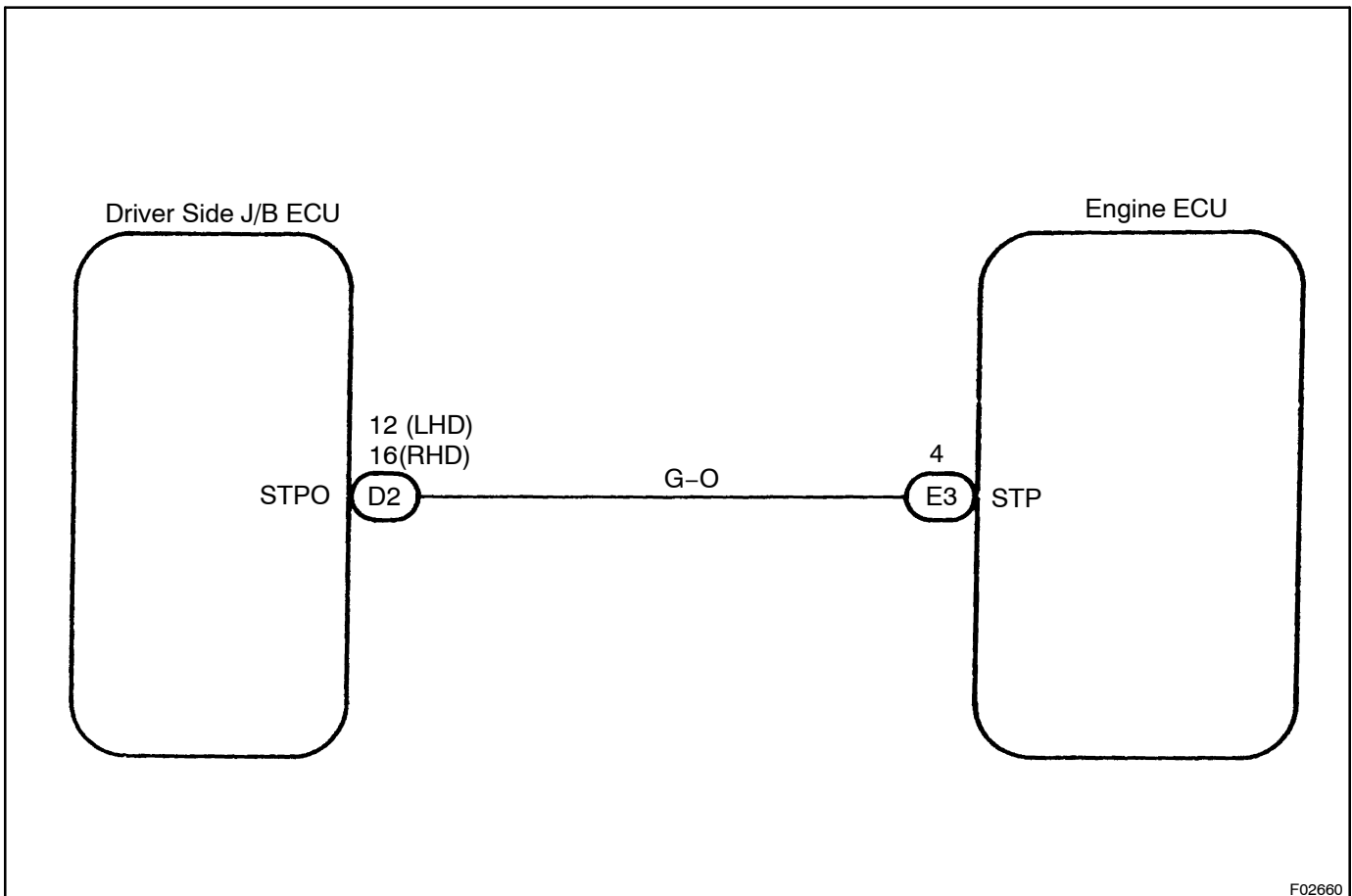

F02660

## INSPECTION PROCEDURE

### HINT:

Read freeze frame data using a hand-held tester. Because freeze frame records the engine conditions when the malfunction is detected. When troubleshooting, it is useful for determining whether the vehicle was running or stopped, the engine was warmed up or not, the air-fuel ratio was lean or rich, etc. at the time of the malfunction.

### 1 Check operation of stop light.

#### CHECK:

Check if the stop lights go on and off normally when the brake pedal is operated and released.

NG

Check and repair stop light circuit.

OK

### 2 Check STP signal.

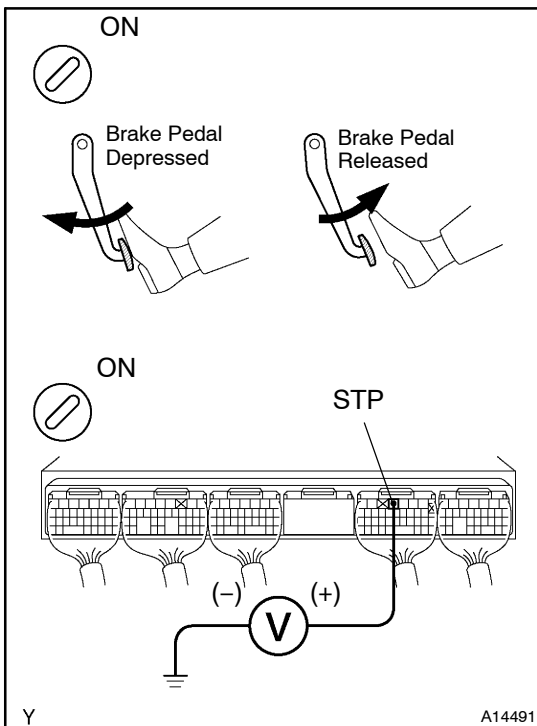

#### When using hand-held tester:

##### PREPARATION:

- Connect the hand-held tester to the DLC3.
- Turn the ignition switch ON and push the hand-held tester main switch ON.

##### CHECK:

Read the STP signal on the hand-held tester.

##### OK:

Brake Pedal	STP Signal
Depressed	ON
Released	OFF

#### When not using hand-held tester:

##### PREPARATION:

Turn the ignition switch ON.

##### CHECK:

Check the voltage between terminal STP of the engine ECU connector and body ground.

##### OK:

Brake Pedal	Voltage
Depressed	7.5 - 14 V
Released	Below 1.5 V

OK

Check for intermittent problems  
(See [page DI-4](#))

NG

3 Check harness and connector between engine ECU and stop light switch (See page IN-35).

NG

Repair or replace harness or connector.

OK

Check and replace engine ECU (See page IN-35).