

GENERAL

CONTENTS

1. ENGINE AND TRANSMISSION MODEL	00A-1-1
2. ENGINE MODEL AND SERIAL NUMBER	00A-2-1
3. PRECAUTIONS BEFORE SERVICE	00A-3-1
4. TIGHTENING TORQUE	00A-4-1

1. ENGINE AND TRANSMISSION MODEL

EUROPE for 1990

Brand	Vehicle model	Engine					Fuel system	Transmission		
		Model (lit.)	Silent shaft	Camshaft	Lash adjuster	Turbo charger		Model	Type	4WD
Lancer station wagon	C12V	4G15-1 (1.5)	–	Single	–	–	CARB	F5M21-1	5M/T	–
								F3A21-2	3A/T	–
	C14V	4D65-1 (1.8)	X	Single	–	–	Diesel S-QGS	F5M21-1	5M/T	–
								F3A21-2	3A/T	–
C37V	4G37-8 (1.8)	–	Single	–	–	CARB	W5M31-1	5M/T	X	
							ELEC. CARB	W5M31-1	5M/T	X
Colt	C51V	4G13-1 (1.3)	–	Single	–	–	CARB	F4M21-1	4M/T	–
	C51A	4G13-1 (1.3)	–	Single	–	–	CARB	F4M21-1	4M/T	–
								F5M21-1	5M/T	–
	C52A	4G15-1 (1.5)	–	Single	–	–	CARB	F5M21-1	5M/T	–
								F3A21-2	3A/T	–
	C53A	4G61-0 (1.6)	–	Double	X	–	MPI	F5M21-1	5M/T	–
								F4A21-2	4A/T	–
	C54A	4D65-1 (1.8)	X	Single	–	–	Diesel S-QGS	F5M22-1	5M/T	–
C58A	4G67-0 (1.8)	X	Double	X	–	MPI	F5M22-2	5M/T	–	
Lancer	C61A	4G13-1 (1.3)	–	Single	–	–	CARB	F4M21-1	4M/T	–
								F5M21-1	5M/T	–
	C62A	4G15-1 (1.5)	–	Single	–	–	CARB	F5M21-1	5M/T	–
								F3A21-2	3A/T	–
	C63A	4G61-0 (1.6)	–	Double	X	–	MPI	F5M21-1	5M/T	–
								F4A21-2	4A/T	–
C64A	4D65-1 (1.8)	X	Single	–	–	Diesel S-QGS	F5M22-1	5M/T	–	

EUROPE for 1990

Brand	Vehicle model	Engine					Fuel system	Transmission		
		Model (lit.)	Silent shaft	Camshaft	Lash adjuster	Turbo charger		Model	Type	4WD
Lancer	C65A	4G16-1 (1.2)	–	Single	–	–	CARB	F5M21-1	5M/T	–
	C68A	4G67-0 (1.8)	X	Double	X	–	MPI	F5M22-2	5M/T	–
	C77A	4G37-8 (1.8)	–	Single	–	–	MPI	W5M31-2	5M/T	X
Galant	E32A	4G37-7 (1.8)	X	Single	–	–	MPI	F5M22-1 F4A22-2	5M/T 4A/T	– –
	E39A	4G63-5 (2.0)	X	Double	X	–	MPI	W5M31-2	5M/T	X
Galant Hatch Back	E32A	4G37-7 (1.8)	X	Single	–	–	MPI	F5M22-1 F4A22-2	5M/T 4A/T	– –
	E39A	4G63-5 (2.0)	X	Double	X	–	MPI	W5M31-2	5M/T	X
Sapporo	E16AT	4G64-1 (2.4)	X	Single	X	–	MPI	F5M31-2 F4A22-1	5M/T 4A/T	– –
Space Wagon Van	D05V	4G37-7 (1.8)	X	Single	–	–	CARB	F5M21-1	5M/T	–
	D09V	4D65-1 (1.8)	X	Single	–	X	Diesel S-QGS	F5M22-1	5M/T	–
	D04W	4G63-3 (2.0)	X	Single	X	–	MPI	F5M22-1 F3A22-2	5M/T 3A/T	– –
	D05W	4G37-7 (1.8)	X	Single	–	–	CARB	F5M21-1 F3A21-2	5M/T 3A/T	– –
	D09W	4D65-1 (1.8)	X	Single	–	X	Diesel S-QGS	F5M22-1	5M/T	–
Space Wagon 4WD	D08W	4G63-3 (2.0)	X	Single	X	–	MPI	KM182-2	5M/T	X
							CRAB	KM182-2	5M/T	X
Pajero	L042G	4G54-1 (2.6)	X	Single	X	–	CARB	V5M21-4	5M/T	X
		G54B-1 (2.6)	X	Single	X	–	ELEC. CARB	V5M21-4	5M/T	X
	L047G	4G54-1 (2.6)	X	Single	X	–	CARB	V5M21-4	5M/T	X
	L049G	4D56-1 (2.5)	X	Single	–	X	Diesel	V5M21-4	5M/T	X
	L141G	6G72-1 (3.0)	–	Double	X	–	MPI	V5MT1-1	5M/T	X

EUROPE for 1990

Brand	Vehicle model	Engine					Fuel system	Transmission		
		Model (lit.)	Silent shaft	Camshaft	Lash adjuster	Turbo charger		Model	Type	4WD
Pajero	L144G	4D56-1 (2.5)	X	Single	–	X	Diesel	V5MT1-1 V4AW2-1	5M/T 4A/T	X X
	L146G	6G72-1 (3.0)	–	Double	X	–	MPI	V5MT1-1 V4AW2-1	5M/T 4A/T	X X
	L149G	4D56-1 (2.5)	X	Single	–	X	Diesel	V5MT1-1 V4AW2-1	5M/T 4M/T	X X
Starion	A187A	G54B-1 (2.6)	X	Single	X	X	SPI	R5M21-4	5M/T	–
L200	K11T	4G32-8 (1.6)	–	Single	–	–	CARB	R5M21-1	5M/T	–
	K12T	4G63-3 (2.0)	X	Single	X	–	CARB	R5M21-1 KM132-H	5M/T 5M/T	– –
	K14T	4D56-1 (2.5)	X	Single	–	–	Diesel	R5M21-1	5M/T	–
L200 4WD	K22T K32T	4G63-3 (2.0)	X	Single	X	–	CARB	V5M21-1	5M/T	X
	K24T K34T	4D56-1 (2.5)	X	Single	–	–	Diesel	V5M21-1	5M/T	X
	K33T	G54B-1 (2.6)	X	Single	X	–	ELEC. CARB	V5M21-1	5M/T	X
L300	P02V P12V	4G32-8 (1.6)	–	Single	–	–	CARB	R5M21-2	5M/T	–
	L032P	4G32-8 (1.6)	–	Single	–	–	CARB	R5M21-3	5M/T	–
	P03V P03W	4G63-3 (2.0)	X	Single	X	–	CARB	R5M21-2	5M/T	–
	P13V						ELEC. CARB	R5M21-2	5M/T	–
	P05V P05W P15V	4D56-1 (2.5)	X	Single	–	–	Diesel	R5M21-2	5M/T	–
	L039P	4D56-1 (2.5)	X	Single	–	–	Diesel S-QGS	R5M21-3	5M/T	–

EUROPE for 1990

Brand	Vehicle model	Engine					Fuel system	Transmission		
		Model (lit.)	Silent shaft	Camshaft	Lash adjuster	Turbo charger		Model	Type	4WD
L300 4WD	P23V P23W	4G63-3 (2.0)	X	Single	X	–	CARB	V5M21-2	5M/T	X
	P24V P24W	4G64-1 (2.4)	X	Single	X	–	MPI	V5M21-2	5M/T	X
	P25V P25W	4D56-1 (2.5)	X	Single	–	X	Diesel S-QGS	V5M21-2	5M/T	X

GENERAL EXPORT for 1990

Brand	Vehicle model	Engine					Fuel system	Transmission		
		Model (lit.)	Silent shaft	Camshaft	Lash adjuster	Turbo charger		Model	Type	4WD
Lancer Station Wagon	C11V	4G13-1 (1.3)	–	Single	–	–	CARB	F4M21-1 F5M21-1	4M/T 5M/T	–
	C12V	4G15-1 (1.5)	–	Single	–	–	CARB	F5M21-1 F3A21-2	5M/T 3A/T	–
	C37V	4G37-8 (1.8)	–	Single	–	–	CARB	W5M31-1	5M/T	X
Colt	C51A	4G13-1 (1.3)	–	Single	–	–	CARB	F5M21-1	5M/T	–
	C52A	4G15-1 (1.5)	–	Single	–	–	CARB	F5M21-1 F3A21-2	5M/T 3A/T	–
	C53A	4G61-0 (1.6)	–	Double	X	–	MPI	F5M22-2	5M/T	–
	C54A	4D65-1 (1.8)	X	Single	–	–	Diesel S-QGS	F5M21-1	5M/T	–
Lancer	C61A	4G13-1 (1.3)	–	Single	–	–	CARB	F4M21-1 F5M21-1 F3A21-2	4M/T 5M/T 3A/T	– – –
	C62A	4G15-1 (1.5)	–	Single	–	–	CARB	F5M21-1 F3A21-2	5M/T 3A/T	– –
							MPI	F5M21-1 F4A21-2	5M/T 4A/T	– –
	C63A	4G61-0 (1.6)	–	Double	X	–	MPI	F5M22-2	5M/T	–
	C64A	4D65-1 (1.8)	X	Single	–	–	Diesel S-QGS	F5M21-1 F5M22-1	5M/T 5M/T	– –
Space Wagon	D05W	4G37-7 (1.8)	X	Single	–	–	CARB	F5M21-1 F3A21-2	5M/T 3A/T	– –
	D04W	4G63-3 (2.0)	X	Single	–	–	CARB	F5M22-1	5M/T	–
Galant	E15A	4G63-3 (2.0)	X	Single	–	–	CARB	F5M22-1	5M/T	–
	E16A	4G64-1 (2.4)	X	Single	–	–	MPI	F5M31-2 F4A22-1	5M/T 4A/T	– –
Galant	E32A	4G37-7 (1.8)	X	Single	–	–	CARB	F5M22-1 F4A21-2	5M/T 4A/T	– –
	E33A	4G63-3 (2.0)	X	Single	–	–	CARB	F5M22-1 F4A22-2	5M/T 4A/T	– –
		4G63-5 (2.0)	X	Double	X	–	MPI	F5M22-2	5M/T	–

GENERAL EXPORT for 1990

Brand	Vehicle model	Engine					Fuel system	Transmission		
		Model (lit.)	Silent shaft	Camshaft	Lash adjuster	Turbo charger		Model	Type	4WD
Pajero	L042G L047G	4G54-1 (2.6)	–	Single	–	–	CARB	V5M21-4 V4AW2-1	5M/T 4A/T	X X
	L044G	4D56-1 (2.5)	X	Single	–	–	Diesel	V5M21-4	5M/T	X
	L049G	4D56-1 (2.5)	X	Single	–	–	Diesel Diesel	V5M21-4 V5M21-4	5M/T 5M/T	X X
	L146G	6G72-1 (3.0)	–	Double	X	–	MPI	V5MT1-1 V4AW2-1	5M/T 4A/T	X X
Starion	A183A	4G63-0 (2.0)	X	Single	–	X	SPI	R5M21-4	5M/T	–
L200	K01T K11T	4G32-8 (1.6)	–	Single	–	–	CARB	R4M21-1	4M/T	–
	K02T K12T	4G63-4 (2.0)	–	Single	–	–	CARB	R5M21-1	5M/T	–
	K14T	4D56-1 (2.5)	X	Single	–	–	Diesel	R5M21-1	5M/T	–
L200 4WD	K22T K32T	4G63-4 (2.0)	–	Single	–	–	CARB	V5M21-1	5M/T	X
	K24T K34T	4D56-1 (2.5)	X	Single	–	–	Diesel	V5M21-1	5M/T	X
L300	P01V P01W	4G33-8 (1.4)	–	Single	–	–	CARB	R4M21-2	4M/T	–
	P02V P12V P12W	4G32-8 (1.6)	–	Single	–	–	CARB	R4M21-2	4M/T	–
	P02W	4G32-8 (1.6)	–	Single	–	–	CARB	R5M21-2	5M/T	–
	P03W P13W	4G63-4 (2.0)	–	Single	–	–	CARB	R5M21-2 R4AW2-2	5M/T 4A/T	– –
	P05V P05W P15V P15W	4D56-1 (2.5)	–	Single	–	–	Diesel	R5M21-2	5M/T	–
L300 4WD	P23W	4G63-4 (2.0)	–	Single	–	–	CARB	V5M21-2	5M/T	X

AUSTRALIA for 1990

Brand	Vehicle model	Engine					Fuel system	Transmission		
		Model (lit.)	Silent shaft	Camshaft	Lash adjuster	Turbo charger		Model	Type	4WD
Lancer	C52A	4G15-1 (1.5)	-	Single	-	-	MPI	F5M21-1	5M/T	-
								F4A21-2	4A/T	-
	C62A	4G15-1 (1.5)	-	Single	-	-	CARB	F5M21-1 F3A21-2	5M/T 3A/T	- -
							MPI	F5M21-1 F4A21-2	5M/T 4A/T	- -
Space Wagon	D04W	4G63-3 (2.0)	X	Single	X	-	CARB	F5M22-1 F3A22-2	5M/T 3A/T	- -
Pajero	L042G L047G	4G54-1 (2.6)	X	Single	X	-	CARB	V5M21-4	5M/T	X
	L049G	4D56-1 (2.5)	X	Single	-	X	Diesel	V5M21-4	5M/T	X
	L149G	4D56-1 (2.5)	X	Single	-	X	Diesel	V5MT1-1	5M/T	X
	L146G	6G72-1 (3.0)	-	Double	X	-	MPI	V5MT1-1 V4AW2-1	5M/T 4A/T	X X
L200	K13T	4G54-1 (2.6)	X	Single	X	-	CARB	R5M21-1	5M/T	-
	K14T	4D56-1 (2.5)	X	Single	-	-	Diesel	R5M21-1	5M/T	-
L200 4WD	K33T	4G54-1 (2.6)	X	Single	X	-	CARB	V5M21-1	5M/T	X
	K34T	4D56-1 (2.6)	X	Single	-	-	Diesel	V5M21-1	5M/T	X
L300	P03V P03W P13V	4G63-3 (2.0)	X	Single	X	-	CARB	R5M21-2 R4AW2-2	5M/T 4A/T	- -
	P04W	4G64-1 (2.4)	X	Single	X	-	MPI	R5M21-2 R4AW2-2	5M/T 4A/T	- -
	P05V P15V	4D56-1 (2.5)	X	Single	-	-	Diesel	R5M21-2	5M/T	-
L300 4WD	P24V P24W	4G64-1 (2.4)	X	Single	X	-	MPI	V5M21-2	5M/T	X

EUROPE for 1991

Brand	Vehicle model	Engine					Fuel system	Transmission		
		Model (lit.)	Silent shaft	Camshaft	Lash adjuster	Turbo charger		Model	Type	4WD
Lancer Station Wagon	C12V	4G15-2 (1.5)	–	Single	–	–	CARB	F5M21-1	5M/T	–
								F3A21-2	3A/T	–
	C14V	4D65-1 (1.8)	X	Single	–	–	Diesel S-QGS	F5M22-1	5M/T	–
C37V	4G37-8 (1.8)	–	Single	–	–	CARB	W5M31-1	5M/T	X	
							MPI	W5M31-1	5M/T	X
Colt	C51V	4G13-2 (1.3)	–	Single	–	–	CARB	F5M21-1	5M/T	–
	C51A	4G13-2 (1.3)	–	Single	–	–	CARB	F5M21-1	5M/T	–
								ELEC. CARB	F5M21-1	5M/T
	C52A	4G15-2 (1.5)	–	Single	–	–	CARB	F5M21-1	5M/T	–
								F3A21-2	3A/T	–
	C54A	4D65-1 (1.8)	X	Single	–	–	Diesel S-QGS	F5M22-1	5M/T	–
	C58A	4G67-0 (1.8)	X	Double	X	–	MPI	F5M22-2	5M/T	–
C87A	4G37-8 (1.8)	–	Single	–	–	MPI	W5M31-2	5M/T	X	
Lancer	C61A	4G13-2 (1.3)	–	Single	–	–	CARB	F5M21-1	5M/T	–
								ELEC. CARB	F5M21-1	5M/T
	C62A	4G15-2 (1.5)	–	Single	–	–	CARB	F5M21-1	5M/T	–
								F3A21-2	3A/T	–
	C64A	4D65-1 (1.8)	X	Single	–	–	Diesel S-QGS	F5M22-1	5M/T	–
C65A	4G16-1 (1.2)	–	Single	–	–	CARB	F5M21-1	5M/T	–	
C68A	4G67-0 (1.8)	X	Double	X	–	CARB	F5M22-2	5M/T	–	

EUROPE for 1991

Brand	Vehicle model	Engine					Fuel system	Transmission		
		Model (lit.)	Silent shaft	Camshaft	Lash adjuster	Turbo charger		Model	Type	4WD
Lancer	C77A	4G37-8 (1.8)	–	Single	–	–	MPI	W5M31-2	5M/T	X
Galant	E31A	4G32-8 (1.6)	–	Single	–	–	CARB	F5M21-1	5M/T	–
	E32A	4G37-7 (1.8)	X	Single	–	–	CARB	F5M22-1 F4A21-2	5M/T 4A/T	– –
							MPI	F5M22-1 F4A22-2	5M/T 4A/T	– –
	E33A	4G63-3 (2.0)	X	Single	X	–	MPI	F5M22-1 F4A22-2	5M/T 4A/T	– –
		4G63-5 (2.0)	X	Double	X	–	MPI	F5M22-2	5M/T	–
	E34A	4D65-1 (1.8)	X	Single	–	X	Diesel S-QGS	F5M31-1 F4A21-2	5M/T 4A/T	– –
	E38A	4G63-3 (2.0)	X	Single	X	–	MPI	W5M31-2	5M/T	X
	E39A	4G63-3 (2.0)	X	Single	X	–	MPI	W5M31-2	5M/T	X
4G63-5 (2.0)		X	Double	X	–	MPI	W5M31-2	5M/T	X	
Space Wagon Van	D05V	4G37-7 (1.8)	X	Single	–	–	CARB	F5M21-1	5M/T	–
	D09V	4D65-1 (1.8)	X	Single	–	X	Diesel S-QGS	F5M22-1	5M/T	–
	D04W	4G63-3 (2.0)	X	Single	X	–	MPI	F5M22-1 F3A22-2	5M/T 3A/T	– –
	D05W	4G37-7 (1.8)	X	Single	–	–	CARB	F5M21-1 F3A21-2	5M/T 3A/T	– –
	D09W	4D65-1 (1.8)	X	Single	–	X	Diesel S-QGS	F5M22-1	5M/T	–
Space Wagon 4WD	D08W	4G63-3 (2.0)	X	Single	X	–	CARB	KM182-2	5M/T	X
							MPI	KM182-2	5M/T	X
Pajero	V21C	4G64-1 (2.4)	X	Single	X	–	MPI	V5M21-5	5M/T	X
	V23C	6G72-1 (3.0)	–	Double	X	–	MPI	V4AW2-3	4A/T	X
	V24C	4D56-1 (2.5)	X	Single	–	X	Diesel	V5MT1-3	5M/T	X

EUROPE for 1991

Brand	Vehicle model	Engine					Fuel system	Transmission		
		Model (lit.)	Silent shaft	Camshaft	Lash adjuster	Turbo charger		Model	Type	4WD
Pajero	V24V V44V	4D56-1 (2.5)	X	Single	–	X	Diesel	V5MT1-3	5M/T	X
	V21W	4G64-1 (2.4)	X	Single	X	–	MPI	V5M21-5	5M/T	X
	V23W	6G72-1 (3.0)	–	Double	X	–	MPI	V4AW2-3	4A/T	X
	V24W	4D56-1 (2.5)	X	Single	–	X	Diesel	V5MT1-3	5M/T	X
	V41W	4G64-1 (2.4)	X	Single	X	–	MPI	V5M21-5	5M/T	X
	V43W	6G72-1 (3.0)	–	Double	X	–	MPI	V5MT1-3 V4AW2-3	5M/T 4A/T	X X
	V44W	4D56-1 (2.5)	X	Single	–	X	Diesel	V5MT1-3 V4AW2-3	5M/T 4A/T	X X
L200	K11T	4G32-8 (1.6)	–	Single	–	–	CARB	R5M21-1	5M/T	–
	K12T	4G63-3 (2.0)	X	Single	X	–	CARB	R5M21-1	5M/T	–
	K14T	4D56-1 (2.5)	X	Single	–	–	Diesel	R5M21-1	5M/T	–
L200 4WD	K22T K32T	4G63-3 (2.0)	X	Single	X	–	CARB	V5M21-1	5M/T	X
	K24T K34T	4D56-1 (2.5)	X	Single	–	–	Diesel	V5M21-1	5M/T	X
	K33T	G54B-1 (2.6)	X	Single	X	–	ELEC. CARB	V5M21-1	5M/T	X
L300	P02V P12V	4G32-8 (1.6)	–	Single	–	–	CARB	R5M21-2	5M/T	–
	L032P	4G32-8 (1.6)	–	Single	–	–	CARB	R5M21-3	5M/T	–
	P03W	4G63-3 (2.0)	X	Single	X	–	CARB	R5M21-2	5M/T	–
							ELEC. CARB	R5M21-2	5M/T	–
	P03V	4G63-3 (2.0)	X	Single	X	–	ELEC. CARB	R5M21-2	5M/T	–
	P13V	4G63-3 (2.0)	X	Single	X	–	CARB	R5M21-2	5M/T	–
ELEC. CARB							R5M21-2	5M/T	–	

EUROPE for 1991

Brand	Vehicle model	Engine					Fuel system	Transmission		
		Model (lit.)	Silent shaft	Camshaft	Lash adjuster	Turbo charger		Model	Type	4WD
L300	P04W	4G64-1 (2.4)	X	Single	X	–	MPI	R5M21-2	5M/T	–
	P05V P05W P15V	4D56-1 (2.5)	X	Single	–	–	Diesel	R5M21-2	5M/T	–
	L039P	4D56-1 (2.5)	–	Single	–	–	Diesel	R5M21-3	5M/T	–
							Diesel S-QGS	R5M21-3	5M/T	–
L300 4WD	P23V P23W	4G63-3 (2.0)	X	Single	X	–	CARB	V5M21-2	5M/T	X
	P24V P24W	4G64-1 (2.4)	X	Single	X	–	ELEC. CARB	V5M21-2	5M/T	X
	P25V P25W	4D56-1 (2.5)	X	Single	–	X	Diesel S-QGS	V5M21-2	5M/T	X
Sigma	F16A	6G72-1 (3.0)	–	Double	X	–	MPI	F5M33-2 F4A33-1	5M/T 4A/T	– –
		6G72-4 (3.0)	–	Four	X	–	MPI	F5M33-2 F4A33-1	5M/T 4A/T	– –
Eclipse	D22A	4G63-5 (2.0)	X	Double	X	–	MPI	F5M31-2	5M/T	–
	D27A	4G63-5 (2.0)	X	Double	X	–	MPI	W5M31-2	5M/T	X

GENERAL EXPORT for 1991

Brand	Vehicle model	Engine					Fuel system	Transmission		
		Model (lit.)	Silent shaft	Camshaft	Lash adjuster	Turbo charger		Model	Type	4WD
Lancer Station Wagon	C11V	4G13-2 (1.3)	–	Single	–	–	CARB	F4M21-1	4M/T	–
								F5M21-1	5M/T	–
	C12V	4G15-2 (1.5)	–	Single	–	–	CARB	F5M21-1 F3A21-2	5M/T 3A/T	– –
	C37V	4G37-8 (1.8)	–	Single	–	–	CARB	W5M31-1	5M/T	X
Colt	C51A	4G13-2 (1.3)	–	Single	–	–	CARB	F5M21-1	5M/T	–
	C52A	4G15-2 (1.5)	–	Single	–	–	CARB	F5M21-1 F3A21-2	5M/T 3A/T	– –
	C54A	4D65-1 (1.8)	X	Single	–	–	Diesel S-QGS	F5M21-1	5M/T	–
	C58A	4G67-0 (1.8)	X	Double	X	–	MPI	F5M22-2	5M/T	–
Lancer	C61A	4G13-2 (1.3)	–	Single	–	–	CARB	F4M21-1	4M/T	–
								F5M21-1	5M/T	–
								F3A21-2	3A/T	–
	C62A	4G15-2 (1.5)	–	Single	–	–	CARB	F5M21-1 F3A21-2	5M/T 3A/T	– –
								MPI	F5M21-1 F4A21-2	5M/T 4A/T
C64A	4D65-1 (1.8)	X	Single	–	–	Diesel S-QGS	F5M21-1 F5M22-1	5M/T 5M/T	– –	
C68A	4G67-0 (1.8)	X	Double	X	–	MPI	F5M22-2	5M/T	–	
Space Wagon	D05W	4G37-7 (1.8)	X	Single	–	–	CARB	F5M21-1 F3A21-2	5M/T 3A/T	–
	D04W	4G63-3 (2.0)	X	Single	–	–	CARB	F5M22-1	5M/T	–
Galant	E15A	4G63-3 (2.0)	X	Single	–	–	CARB	F5M22-1	5M/T	–
Galant	E31A	4G32-8 (1.6)	–	Single	–	–	CARB	F5M21-1	5M/T	–
								F4A21-2	4A/T	–
	E32A	4G37-7 (1.8)	X	Single	–	–	CARB	F5M22-1	5M/T	–
								F4A21-2	4A/T	–
	E33A	4G63-3 (2.0)	X	Single	–	–	CARB	F5M22-1	5M/T	–
F4A22-2								4A/T	–	
MPI								F5M22-1 F4A22-2	5M/T 4A/T	– –
	4G63-5 (2.0)	X	Double	X	–	MPI	F5M22-2 F4A22-2	5M/T 4A/T	– –	

GENERAL EXPORT for 1991

Brand	Vehicle model	Engine					Fuel system	Transmission		
		Model (lit.)	Silent shaft	Camshaft	Lash adjuster	Turbo charger		Model	Type	4WD
Galant	E39A	4G63-5 (2.0)	X	Double	X	X	MPI	W5M33-2	5M/T	X
Pajero	L042G	4G54-1 (2.6)	–	Single	–	–	CARB	V5M21-4	5M/T	X
	L044G	4D56-1 (2.5)	X	Single	–	–	Diesel	V5M21-4	5M/T	X
	L047G	4G54-1 (2.6)	–	Single	–	–	CARB	V5M21-4 V4AW2-1	5M/T 4A/T	X X
	L049G	4D56-1 (2.5)	X	Single	–	–	Diesel Diesel	V5M21-4 V5M21-4	5M/T 5M/T	X X
	L146G	6G72-1 (3.0)	–	Double	X	–	MPI	V5MT1-1 V4AW2-1	5M/T 4A/T	X X
	V12C V12V V12W V32V	4G54-1 (2.6)	–	Single	–	–	CARB	V5M21-5	5M/T	X
	V14C V14V V34V	4D56-1 (2.5)	X	Single	–	–	Diesel	V5M21-5	5M/T	X
	V23W V43W	6G72-1 (3.0)	–	Double	X	–	MPI	V5MT1-3	5M/T	X
	V24W V44W	4D56-1 (2.5)	X	Single	–	–	Diesel	V5MT1-3	5M/T	X
	V32W	4G54-1 (2.6)	–	Single	–	–	CARB	V5M21-3 V4AW2-3	5M/T 4A/T	X X
L200	K01T K11T	4G32-8 (1.6)	–	Single	–	–	CARB	R4M21-1	4M/T	–
	K02T K12T	4G63-4 (2.0)	–	Single	–	–	CARB	R5M21-1	5M/T	–
	K03T K13T	4G54-1 (2.6)	–	Single	–	–	CARB	R5M21-1	5M/T	–
	K14T	4D56-1 (2.5)	X	Single	–	–	Diesel	R5M21-1	5M/T	–
L200 4WD	K22T K32T	4G63-4 (2.0)	–	Single	–	–	CARB	V5M21-1	5M/T	X
	K24T K34T	4D56-1 (2.5)	X	Single	–	–	Diesel	V5M21-1	5M/T	X

GENERAL EXPORT for 1991

Brand	Vehicle model	Engine					Fuel system	Transmission		
		Model (lit.)	Silent shaft	Camshaft	Lash adjuster	Turbo charger		Model	Type	4WD
L300	P01V P01W	4G33-8 (1.4)	–	Single	–	–	CARB	R4M21-2	4M/T	–
	P02V P12V P12W	4G32-8 (1.6)	–	Single	–	–	CARB	R4M21-2	4M/T	–
	P03V P13V P13W	4G63-4 (2.0)	–	Single	–	–	CARB	R5M21-2	5M/T	–
	P03W	4G63-4 (2.0)	–	Single	–	–	CARB	R5M21-2 R4AW2-2	5M/T 4A/T	–
	P05V P15V P15W	4D56-1 (2.5)	X	Single	–	–	Diesel	R5M21-2	5M/T	–
	P05W	4D56-1 (2.5)	X	Single	–	–	Diesel	R5M21-2 R4AW2-2	5M/T 4A/T	–
L300 4WD	P23W	4G63-4 (2.0)	–	Single	–	–	CARB	V5M21-2	5M/T	X

AUSTRALIA for 1991

Brand	Vehicle model	Engine					Fuel system	Transmission		
		Model (lit.)	Silent shaft	Camshaft	Lash adjuster	Turbo charger		Model	Type	4WD
Lancer	C52A	4G15-2 (1.5)	–	Single	–	–	MPI	F5M21-1	5M/T	–
								F4A21-2	4A/T	–
	C53A C63A	4G61-0 (1.6)	–	Double	X	–	MPI	F5M22-2	5M/T	–
C62A	4G15-2 (1.5)	–	Single	–	–	CARB	F5M21-1 F3A21-2	5M/T 3A/T	– –	
						MPI	F5M21-1 F4A21-2	5M/T 4A/T	– –	
Galant	E33A	4G63-3 (2.0)	X	Single	X	–	MPI	F5M22-1 F4A22-2	5M/T 4A/T	– –
		4G63-5 (2.0)	X	Double	X	–	MPI	F5M22-2 F4A22-2	5M/T 4A/T	– –
	E39A	4G63-5 (2.0)	X	Double	X	X	MPI	W5M33-2	5M/T	X
Space Wagon	D04W	4G63-3 (2.0)	X	Single	X	–	CARB	F5M22-1 F3A22-2	5M/T 3A/T	– –
Pajero	V12W V32W	4G54-1 (2.6)	X	Single	X	–	CARB	V5M21-5	5M/T	X
	V23W	6G72-1 (3.0)	–	Double	X	–	MPI	V5MT1-3	5M/T	X
	V43W	6G72-1 (3.0)	–	Double	X	–	MPI	V5MT1-3 V4AW2-3	5M/T 4A/T	X X
V44W	4D56-1 (2.5)	X	Single	–	X	Diesel Diesel	V5M21-5 V5MT1-3	5M/T 5M/T	X X	
L200	K13T	4G54-1 (2.6)	X	Single	X	–	CARB	R5M21-1	5M/T	–
	K14T	4D56-1 (2.5)	X	Single	–	–	Diesel	R5M21-1	5M/T	–
L200 4WD	K33T	4G54-1 (2.6)	X	Single	X	–	CARB	V5M21-1	5M/T	X
	K34T	4D56-1 (2.5)	X	Single	–	X	Diesel	V5M21-1	5M/T	X
	K36T	6G72-1 (3.0)	–	Double	X	–	MPI	V5MT1-2	5M/T	X
L300	P03V P03W	4G63-3 (2.0)	X	Single	X	–	CARB	R5M21-2 R4AW2-2	5M/T 4A/T	– –
	P05V P15V	4D56-1 (2.5)	X	Single	–	–	Diesel S-QGS	R5M21-2 R4AW2-2	5M/T 4A/T	– –

AUSTRALIA for 1991

Brand	Vehicle model	Engine					Fuel system	Transmission		
		Model (lit.)	Silent shaft	Camshaft	Lash adjuster	Turbo charger		Model	Type	4WD
L300	P04W	4G64-1 (2.4)	X	Single	X	–	MPI	R5M21-2 R4AW2-2	5M/T 4A/T	– –
L300 4WD	P24V P24W	4G64-1 (2.4)	X	Single	X	–	MPI	V5M21-2	5M/T	X
Sigma	F06A	4G54-1 (2.6)	X	Single	X	–	CARB	F5M31-2 F4A23-2	5M/T 4A/T	– –
							MPI	F5M31-2 F4A33-1	5M/T 4A/T	– –
	F07A	6G72-1 (3.0)	–	Double	X	–	MPI	F4A33-1	4A/T	–

EUROPE for 1992

Brand	Vehicle model	Engine					Fuel system	Transmission		
		Model (lit.)	Silent shaft	Camshaft	Lash adjuster	Turbo charger		Model	Type	4WD
Colt	CA1A	4G13-2 (1.3)	–	Single	–	–	MPI	F5M21-1	5M/T	–
	CA4A	4G92-0 (1.6)	–	Single	–	–	MPI	F5M22-2 F4A22-2	5M/T 4A/T	– –
	CA5A	4G93-1 (1.8)	–	Double	X	–	MPI	F5M22-2	5M/T	–
	CC4A	4G92-0 (1.6)	–	Single	–	–	MPI	W5M31-2	5M/T	X
Space Runner	N11W	4G93-0 (1.8)	–	Single	–	–	MPI	F5M22-1 F4A22-2	5M/T 4A/T	– –
	N21W	4G93-0 (1.8)	–	Single	–	–	MPI	W5M31-2	5M/T	X
Space Wagon	N31W	4G93-0 (1.8)	–	Single	–	–	MPI	F5M22-1 F4A22-2	5M/T 4A/T	– –
	N35W	4D65-1 (1.8)	X	Single	–	X	Diesel	F5M31-1	5M/T	–
	N41W	4G93-0 (1.8)	–	Single	–	–	MPI	W5M31-2 W4A32-1	5M/T 4A/T	X X
Galant	E31A	4G32-8 (1.6)	–	Single	–	–	CARB	F5M21-1	5M/T	–
	E32A	4G37-7 (1.8)	X	Single	–	–	CARB	F5M22-1 F4A21-2	5M/T 4A/T	– –
							MPI	F5M22-1 F4A22-2	5M/T 4A/T	– –
	E33A	4G63-3 (2.0)	X	Single	X	–	MPI	F5M22-1 F4A22-2	5M/T 4A/T	– –
		4G63-5 (2.0)	X	Double	X	–	MPI	F5M22-2	5M/T	–
	E34A	4D65-1 (1.8)	X	Single	–	X	Diesel S-QGS	F5M31-1 F4A21-2	5M/T 4A/T	– –
	E38A	4G63-3 (2.0)	X	Single	X	–	MPI	W5M31-2	5M/T	X
	E39A	4G63-3 (2.0)	X	Single	X	–	MPI	W5M31-2	5M/T	X
4G63-5 (2.0)		X	Double	X	–	MPI	W5M31-2	5M/T	X	

EUROPE for 1992

Brand	Vehicle model	Engine					Fuel system	Transmission		
		Model (lit.)	Silent shaft	Camshaft	Lash adjuster	Turbo charger		Model	Type	4WD
L200	K11T	4G32-8 (1.6)	–	Single	–	–	CARB	R5M21-1	5M/T	–
	K12T	4G63-3 (2.0)	X	Single	X	–	CARB	R5M21-1	5M/T	–
	K14T	4D56-1 (2.5)	X	Single	–	–	Diesel	R5M21-1	5M/T	–
L200 4WD	K22T K32T	4G63-3 (2.0)	X	Single	X	–	CARB	V5M21-1	5M/T	X
	K24T K34T	4D56-1 (2.5)	X	Single	–	–	Diesel	V5M21-1	5M/T	X
	K33T	G54B-1 (2.6)	X	Single	X	–	ELEC. CARB	V5M21-1	5M/T	X
L300	P02V P12V	4G32-8 (1.6)	–	Single	–	–	CARB	R5M21-2	5M/T	–
	L032P	4G32-8 (1.6)	–	Single	–	–	CARB	R5M21-3	5M/T	–
	P03W	4G63-3 (2.0)	X	Single	X	–	CARB	R5M21-2	5M/T	–
								R4AW2-2	4A/T	–
	P03V	4G63-3 (2.0)	X	Single	X	–	ELEC. CARB	R5M21-2	5M/T	–
								R5M21-2	5M/T	–
	P13V	4G63-3 (2.0)	X	Single	X	–	CARB	R5M21-2	5M/T	–
								R5M21-2	5M/T	–
	P04V P04W P14V	4G64-1 (2.4)	X	Single	X	–	MPI	R5M21-2	5M/T	–
								R5M21-2	5M/T	–
P05V P05W P15V	4D56-1 (2.5)	X	Single	–	–	Diesel	R5M21-2	5M/T	–	
							R5M21-2	5M/T	–	
L039P	4D56-1 (2.5)	X	Single	–	–	Diesel	R5M21-3	5M/T	–	
							R5M21-3	5M/T	–	
						Diesel S-QGS	R5M21-3	5M/T	–	

EUROPE for 1992

Brand	Vehicle model	Engine					Fuel system	Transmission		
		Model (lit.)	Silent shaft	Camshaft	Lash adjuster	Turbo charger		Model	Type	4WD
L300 4WD	P23V P23W	4G63-3 (2.0)	X	Single	X	–	ELEC. CARB	V5M21-2	5M/T	X
	P24V P24W	4G64-1 (2.4)	X	Single	X	–	MPI	V5M21-2	5M/T	X
	P25V P25W P45V	4D56-1 (2.5)	X	Single	–	X	Diesel S-QGS	V5M21-2	5M/T	X
Sigma	F16A	6G72-1 (3.0)	–	Double	X	–	MPI	F5M33-2 F4A33-1	5M/T 4A/T	– –
		6G72-4 (3.0)	–	Four	X	–	MPI	F5M33-2 F4A33-1	5M/T 4A/T	– –

GENERAL EXPORT for 1992

Brand	Vehicle model	Engine					Fuel system	Transmission		
		Model (lit.)	Silent shaft	Camshaft	Lash adjuster	Turbo charger		Model	Type	4WD
Colt	CA1A	4G13-2 (1.3)	–	Single	–	–	CARB	F5M21-1	5M/T	–
	CB1A	4G13-2 (1.3)	–	Single	–	–	CARB	F5M21-1 F3A21-2	5M/T 3A/T	– –
							ELEC CARB	F5M21-1 F3A21-2	5M/T 3A/T	– –
							MPI	F5M21-1	5M/T	–
	CA2A CB2A	4G15-2 (1.5)	–	Single	–	–	CARB	F5M21-1 F3A21-2	5M/T 3A/T	– –
	CA4A CB4A	4G92-0 (1.6)	–	Single	–	–	MPI	F5M22-2 F4A22-2	5M/T 4A/T	– –
CA5A CB5A	4G93-1 (1.8)	–	Double	X	–	MPI	F5M22-2	5M/T	–	
Space Runner	N11W	4G93-0 (1.8)	–	Single	–	–	CARB	F5M22-1 F4A22-2	5M/T 4A/T	– –
							MPI	F5M22-1 F4A22-2	5M/T 4A/T	– –
Space Wagon	N31W	4G93-0 (1.8)	–	Single	–	–	CARB	F5M22-1 F4A22-2	5M/T 4A/T	– –
							MPI	F5M22-1 F4A22-2	5M/T 4A/T	– –
Galant	E31A	4G32-8 (1.6)	–	Single	–	–	CARB	F5M21-1 F4A21-2	5M/T 4A/T	– –
	E32A	4G37-7 (1.8)	X	Single	–	–	CARB	F5M22-1 F4A21-2	5M/T 4A/T	– –
							MPI	F5M22-1 F4A22-2	5M/T 4A/T	– –
	E33A	4G63-3 (2.0)	X	Single	–	–	CARB	F5M22-1 F4A22-2	5M/T 4A/T	– –
		4G63-3 (2.0)	X	Single	X	–	MPI	F5M22-1 F4A22-2	5M/T 4A/T	– –
	4G63-5 (2.0)	X	Double	X	–	MPI	F5M22-2 F4A22-2	5M/T 4A/T	– –	
E39A	4G63-5 (2.0)	X	Double	X	X	MPI	W5M33-2	5M/T	X	

GENERAL EXPORT for 1992

Brand	Vehicle model	Engine					Fuel system	Transmission		
		Model (lit.)	Silent shaft	Camshaft	Lash adjuster	Turbo charger		Model	Type	4WD
Pajero	V12C V12V V12W V32V	4G54-1 (2.6)	–	Single	–	–	CARB	V5M21-5	5M/T	X
	V14C V14V V34V	4D56-1 (2.5)	X	Single	–	–	Diesel	V5M21-5	5M/T	X
	V23W	6G72-1 (3.0)	–	Double	X	–	MPI	V5MT1-3	5M/T	X
	V24W V44W	4D56-1 (2.5)	X	Single	–	X	Diesel	V5MT1-3	5M/T	X
	V32W	4G54-1 (2.6)	–	Single	–	–	CARB	V5MT1-3 V4AW2-3	5M/T 4A/T	X X
	V43W	6G72-1 (3.0)	–	Double	X	–	MPI	V5MT1-3	5M/T	X
L200	K01T K11T	4G32-8 (1.6)	–	Single	–	–	CARB	R4M21-1	4M/T	–
	K02T K12T	4G63-4 (2.0)	–	Single	–	–	CARB	R5M21-1	5M/T	–
	K03T K13T	4G54-1 (2.6)	–	Single	–	–	CARB	R5M21-1	5M/T	–
	K14T	4D56-1 (2.5)	X	Single	–	–	Diesel	R5M21-1	5M/T	–
L200 4WD	K22T K32T	4G63-4 (2.0)	–	Single	–	–	CARB	V5M21-1	5M/T	X
	K24T K34T	4D56-1 (2.5)	X	Single	–	–	Diesel	V5M21-1	5M/T	X
L300	P01V P01W	4G33-8 (1.4)	–	Single	–	–	CARB	R4M21-2	4M/T	–
	P02V P12V P12W	4G32-8 (1.6)	–	Single	–	–	CARB	R4M21-2	4M/T	–
	P03V P13V P13W	4G63-4 (2.0)	–	Single	–	–	CARB	R5M21-2	5M/T	–
	P03W	4G63-4 (2.0)	–	Single	–	–	CARB	R5M21-2 R4AW2-2	5M/T 4A/T	– –

GENERAL EXPORT for 1992

Brand	Vehicle model	Engine					Fuel system	Transmission		
		Model (lit.)	Silent shaft	Camshaft	Lash adjuster	Turbo charger		Model	Type	4WD
L300	P05V P15V P15W	4D56-1 (2.5)	X	Single	–	–	Diesel	R5M21-2	5M/T	–
	P05W	4D56-1 (2.5)	X	Single	–	–	Diesel	R5M21-2 R4AW2-2	5M/T 4A/T	– –
L300 4WD	P23W	4G63-4 (2.0)	–	Single	–	–	CARB	V5M21-2	5M/T	X
Sigma	F16A	6G72-1 (3.0)	–	Double	X	–	MPI	F5M33-2 F4A33-1	5M/T 4A/T	– –
		6G72-4 (3.0)	–	Four	X	–	MPI	F5M33-2 F4A33-1	5M/T 4A/T	– –
Diamante	F26A	6G72-4 (3.0)	–	Four	X	–	MPI	W4A33-1	4A/T	X

AUSTRALIA for 1992

Brand	Vehicle model	Engine					Fuel system	Transmission		
		Model (lit.)	Silent shaft	Camshaft	Lash adjuster	Turbo charger		Model	Type	4WD
Space Wagon	N31W	4G64-1 (2.4)	X	Single	X	–	MPI	F5M31-2	5M/T	–
								F4A23-2	4A/T	–
Galant	E33A	4G63-3 (2.0)	X	Single	X	–	MPI	F5M22-1	5M/T	–
								F4A22-2	4A/T	–
		4G63-5 (2.0)	X	Double	X	–	MPI	F5M22-2	5M/T	–
	E39A	4G63-5 (2.0)	X	Double	X	X	MPI	W5M33-2	5M/T	X
L200	K13T	4G54-1 (2.6)	X	Single	X	–	CARB	R5M21-1	5M/T	–
	K14T	4D56-1 (2.5)	X	Single	–	–	Diesel	R5M21-1	5M/T	–
L200 4WD	K33T	4G54-1 (2.6)	X	Single	X	–	CARB	V5M21-1	5M/T	X
	K34T	4D56-1 (2.5)	X	Single	–	X	Diesel	V5M21-1	5M/T	X
	K36T	6G72-1 (3.0)	–	Double	X	–	MPI	V5MT1-2	5M/T	X
L300	P03V P03W	4G63-3 (2.0)	X	Single	X	–	CARB	R5M21-2	5M/T	–
								R4AW2-2	4A/T	–
	P04W P14V	4G64-1 (2.4)	X	Single	X	–	MPI	R5M21-2	5M/T	–
								R4AW2-2	4A/T	–
	P05V P15V	4D56-1 (2.5)	X	Single	–	–	Diesel S-QGS	R5M21-2	5M/T	–
								R4AW2-2	4A/T	–
L300 4WD	P24V P24W	4G64-1 (2.4)	X	Single	X	–	MPI	V5M21-2	5M/T	X

EUROPE for 1993

Brand	Vehicle model	Engine					Fuel system	Transmission		
		Model (lit.)	Silent shaft	Camshaft	Lash adjuster	Turbo charger		Model	Type	4WD
Lancer	CB1A	4G13-2 (1.3)	–	Single	–	–	MPI	F5M21-1	5M/T	–
	CB4A CB4W	4G92-0 (1.6)	–	Single	–	–	MPI	F5M22-2 F4A22-2	5M/T 4A/T	–
	CB5A	4G93-1 (1.8)	–	Double	X	–	MPI	F5M22-2	5M/T	–
	CB8A CB8W	4D68-0 (2.0)	X	Single	–	–	Diesel S-QGS	F5M22-1	5M/T	–
	CD4A CD4W	4G92-0 (1.6)	–	Single	–	–	MPI	W5M31-2	5M/T	X
	C61A	4G13-2 (1.3)	–	Single	–	–	CARB	F5M21-1	5M/T	–
	C62A	4G15-2 (1.5)	–	Single	–	–	CARB	F5M21-1 F3A21-2	5M/T 3A/T	– –
	C66A	4G92-0 (1.6)	–	Single	–	–	MPI	F5M22-2 F4A21-2	5M/T 4A/T	– –
	C67A	4D68-0 (2.0)	X	Single	–	–	Diesel S-QGS	F5M22-1	5M/T	–
	C69A	4G93-1 (1.8)	–	Double	X	–	MPI	F5M22-2	5M/T	–
	C76A	4G92-0 (1.6)	–	Single	–	–	MPI	W5M31-2	5M/T	X
Space Runner	N11W	4G93-0 (1.8)	–	Single	–	–	MPI	F5M22-1 F4A22-2	5M/T 4A/T	– –
	N18W	4D68-0 (2.0)	X	Single	–	X	Diesel S-QGS	F5M31-1	5M/T	–
	N21W	4G93-0 (1.8)	–	Single	–	–	MPI	W5M31-2	5M/T	X
Space Wagon	N33W	4G63-6 (2.0)	X	Single	X	–	MPI	F5M22-1 F4A22-2	5M/T 4A/T	– –
	N34W	4G64-2 (2.4)	X	Single	X	–	MPI	F5M31-2 F4A23-2	5M/T 4A/T	– –
	N38W	4D68-0 (2.0)	X	Single	–	X	Diesel S-QGS	F5M31-1	5M/T	–
	N43W	4G63-6 (2.0)	X	Single	X	–	MPI	W5M31-2 F4A32-1	5M/T 4A/T	X X

EUROPE for 1993

Brand	Vehicle model	Engine					Fuel system	Transmission		
		Model (lit.)	Silent shaft	Camshaft	Lash adjuster	Turbo charger		Model	Type	4WD
Galant	E52A	4G93-0 (1.8)	–	Single	–	–	MPI	F5M22-2 F4A22-2	5M/T 4A/T	– –
	E54A	6A12-0 (2.0)	–	Four	X	–	MPI	F5M31-2 F4A23-2	5M/T 4A/T	– –
	E55A	4G63-6 (2.0)	X	Single	X	–	MPI	F5M22-2 F4A22-2	5M/T 4A/T	– –
	E57A	4D68-0 (2.0)	X	Single	–	X	Diesel S-QGS	F5M31-1	5M/T	–
	E64A	6A12-0 (2.0)	–	Four	X	–	MPI	F5M31-2 F4A23-2	5M/T 4A/T	– –
	E75A	4G63-6 (2.0)	X	Single	X	–	MPI	W5M31-2	5M/T	X
	E88A	6G73-1 (2.5)	–	Four	X	–	MPI	W5M33-2	5M/T	X
Pajero/ Montero	V21C V21W V41W	4G64-3 (2.4)	X	Single	X	–	MPI	V5M21-5	5M/T	X
	V23C	6G72-1 (3.0)	–	Double	X	–	MPI	V4AW2-3	4A/T	X
	V23W V43W	6G72-1 (3.0)	–	Double	X	–	MPI	V5MT1-3 V4AW2-3	5M/T 4A/T	X X
	V24C V24W	4D56-1 (2.5)	X	Single	–	X	Diesel	V5MT1-3	5M/T	X
	V44W	4D56-1 (2.5)	X	Single	–	X	Diesel	V5MT1-3 V4AW2-3	5M/T 4A/T	X X
L200	K11T	4G32-8 (1.6)	–	Single	–	–	CARB	R5M21-1	5M/T	–
	K12T	4G63-9 (2.0)	X	Single	X	–	CARB	R5M21-1	5M/T	–
	K14T	4D56-1 (2.5)	X	Single	–	–	Diesel	R5M21-1	5M/T	–
L200 4WD	K22T K32T	4G63-9 (2.0)	X	Single	X	–	CARB	V5M21-1	5M/T	X
	K24T K34T	4D56-1 (2.5)	X	Single	–	X	Diesel	V5M21-1	5M/T	X
	K33T	G54B-1 (2.6)	X	Single	X	–	CARB	V5M21-1	5M/T	X
L300	P02V P12V	4G32-8 (1.6)	–	Single	–	–	CARB	R5M21-2	5M/T	–
	P03V	4G63-9 (2.0)	X	Single	X	–	ELEC. CARB	R5M21-2	5M/T	–

EUROPE for 1993

Brand	Vehicle model	Engine					Fuel system	Transmission		
		Model (lit.)	Silent shaft	Camshaft	Lash adjuster	Turbo charger		Model	Type	4WD
L300	P03W	4G63-9 (2.0)	X	Single	X	–	CARB	R5M21-2	5M/T	–
								R4AW2-2	4A/T	–
	P13V	4G63-9 (2.0)	X	Single	X	–	CARB	R5M21-2	5M/T	–
								ELEC. CARB	R5M21-2	5M/T
	P04V P04W P14V	4G64-3 (2.4)	X	Single	X	–	MPI	R5M21-2	5M/T	–
								ELEC. CARB	R5M21-2	5M/T
	P05V P05W P15V	4D56-1 (2.5)	X	Single	–	–	Diesel	R5M21-2	5M/T	–
L032P								4G32-8 (1.6)	–	Single
L039P	4D56-1 (2.5)	X	Single	–	–	Diesel	R5M21-3	5M/T	–	
							Diesel S-QGS	R5M21-3	5M/T	–
L300 4WD	P24V P24W	4G64-3 (2.4)	X	Single	X	–	MPI	V5M21-2	5M/T	X
								P25V P25W P45W	4D56-1 (2.5)	X
Sigma	F16A	6G72-1	–	Double	X	–	MPI	F5M33-2	5M/T	–
				Four	X	–		F4A33-1	4A/T	–
3000GT	Z16A	6G72-4	–	Four	X	X	MPI	W5MG1-2	5M/T	X
				Eclipse	D22A	4G63-7		X	Double	X
Eclipse	D27A	4G63-7	X	Double	X	–	MPI	W5M33-2	5M/T	X
				Colt	CA1A	4G13-2 (1.3)		–	Single	–
Colt	CA2A	4G15-2 (1.5)	–	Single	–	–	CARB	F5M21-1	5M/T	–
				–	–	–		F3A21-2	3A/T	–
				CA5A	4G93-1 (1.8)	–		Double	X	–
Lancer	CB1A	4G13-2 (1.3)	–	Single	–	–	CARB	F5M21-1	5M/T	–
				CB1W	4G13-2 (1.3)	–		Single	–	–
								F3A21-2	3A/T	–

GENERAL EXPORT for 1993

Brand	Vehicle model	Engine					Fuel system	Transmission		
		Model (lit.)	Silent shaft	Camshaft	Lash adjuster	Turbo charger		Model	Type	4WD
Lancer	CB2A CB2W	4G15-2 (1.5)	–	Single	–	–	CARB	F5M21-1 F3A21-2	5M/T 3A/T	– –
	CB4W	4G92-0 (1.6)	–	Single	–	–	MPI	F5M22-2	5M/T	–
Space Runner	N11W	4G93-0 (1.8)	–	Single	–	–	CARB	F5M22-1 F4A22-2	5M/T 4A/T	– –
							MPI	F5M22-1 F4A22-2	5M/T 4A/T	– –
Space Wagon	N31W	4G93-0 (1.8)	–	Single	–	–	CARB	F5M22-1 F4A22-2	5M/T 4A/T	– –
							MPI	F5M22-1 F4A22-2	5M/T 4A/T	– –
Galant	E52A	4G93-0 (1.8)	–	Single	–	–	CARB	F5M22-2 F4A22-2	5M/T 4A/T	– –
							MPI	F5M22-2 F4A22-2	5M/T 4A/T	– –
	E54A	6A12-0 (2.0)	–	Double	X	–	MPI	F5M31-2 F5A23-2	5M/T 4A/T	– –
E55A	4G63-6 (2.0)	X	Single	X	–	–	CARB	F5M22-2 F4A22-2	5M/T 4A/T	– –
							MPI	F4A22-2	4A/T	–
Pajero/ Montero	V12C V12V V12W V32V	4G54-1 (2.6)	–	Single	–	–	CARB	V5M21-5 V4AW2-3	5M/T 4A/T	X X
	V32W	4G54-1 (2.6)	–	Single	–	–	CARB	V5M21-5	5M/T	X

GENERAL EXPORT for 1993

Brand	Vehicle model	Engine					Fuel system	Transmission		
		Model (lit.)	Silent shaft	Camshaft	Lash adjuster	Turbo charger		Model	Type	4WD
Pajero/ Montero	V23W V43W	6G72-1 (3.0)	–	Double	X	–	MPI	V5MT1-3 V4AW2-3	5M/T 4A/T	X X
	V14C V14V V34V	4D56-1 (2.5)	X	Single	–	–	Diesel	V5M21-5	5M/T	X
	V34V	4D56-1 (2.5)	X	Single	–	X	Diesel	V5M21-5	5M/T	X
	V24W V34W	4D56-1 (2.5)	X	Single	–	X	Diesel	V5MT1-3	5M/T	X
	V44W	4D56-1 (2.5)	X	Single	–	X	Diesel	V5MT1-3 V4AW2-3	5M/T 4A/T	X X
L200	K01T K11T	4G32-8 (1.6)	–	Single	–	–	CARB	R4M21-1	4M/T	–
	K02T K12T	4G63-8 (2.0)	–	Single	–	–	CARB	R5M21-1	5M/T	–
	K03T K13T	4G54-1 (2.6)	–	Single	–	–	CARB	R5M21-1	5M/T	–
	K14T	4D56-1 (2.5)	X	Single	–	–	Diesel	R5M21-1	5M/T	–
L200 4WD	K22T K32T	4G63-8 (2.0)	–	Single	–	–	CARB	V5M21-1	5M/T	X
	K24T K34T	4D56-1 (2.5)	X	Single	–	–	Diesel	V5M21-1	5M/T	X
L300	P01V	4G33-8 (1.4)	–	Single	–	–	CARB	R4M21-2	4M/T	–
		G33B-8 (1.4)	–	Single	–	–	CARB	R4M21-2	4M/T	–
	P01W	4G33-8 (1.4)	–	Single	–	–	CARB	R4M21-2	4M/T	–
	P12V P12W	4G32-8 (1.6)	–	Single	–	–	CARB	R4M21-2	4M/T	–
		P03V P13V P13W	4G63-8 (2.0)	–	Single	–	–	CARB	R5M21-2	5M/T
	P03W		4G63-8 (2.0)	–	Single	–	–	CARB	R5M21-2 R4AW2-2	5M/T 4A/T
	P04W	4G64-3 (2.4)	X	Single	X	–	MPI	R4AW2-2	4A/T	–

GENERAL EXPORT for 1993

Brand	Vehicle model	Engine					Fuel system	Transmission		
		Model (lit.)	Silent shaft	Camshaft	Lash adjuster	Turbo charger		Model	Type	4WD
L300	P05V P15V P15W	4D56-1 (2.5)	X	Single	–	–	Diesel	R5M21-2	5M/T	–
	P05W	4D56-1 (2.5)	X	Single	–	–	Diesel	R5M21-2	5M/T	–
L300 4WD	P23W	4G63-8 (2.0)	–	Single	–	–	CARB	V5M21-2	5M/T	X
	P24W	4G64-3 (2.4)	X	Single	X	–	MPI	V5M21-2	5M/T	X
Sigma	F16A	6G72-1 (3.0)	–	Double	X	–	MPI	F5M33-2 F4A33-1	5M/T 4A/T	– –
		6G72-4 (3.0)	–	Four	X	–	MPI	F5M33-2 F4A33-1	5M/T 4A/T	– –
Diamante	F26A	6G72-4 (3.0)	–	Four	X	–	MPI	W4A33-1	4A/T	X
3000GT	Z16A	6G72-4 (3.0)	–	Four	X	X	MPI	W5MG1-2	5M/T	X

AUSTRALIA for 1993

Brand	Vehicle model	Engine					Fuel system	Transmission		
		Model (lit.)	Silent shaft	Camshaft	Lash adjuster	Turbo charger		Model	Type	4WD
Lancer	CA2A CB2A	4G15-2 (1.5)	–	Single	–	–	CARB	F5M21-1 F3A21-2	5M/T 3A/T	– –
	CA5A CB5A CB5W	4G93-0 (1.8)	–	Single	–	–	MPI	F5M22-2 F4A22-2	5M/T 4A/T	– –
	CD5A	4G93-1 (1.8)	–	Double	X	X	MPI	W5M33-2	5M/T	X
	C62A	4G15-2 (1.5)	–	Single	–	–	CARB	F5M21-1 F3A21-2	5M/T 3A/T	– –
	C66A	4G92-0 (1.6)	–	Single	–	–	MPI	F5M22-2 F4A21-2	5M/T 4A/T	– –
Space Wagon	N34W	4G64-2 (2.4)	X	Single	X	–	MPI	F5M31-2 F4A23-2	5M/T 4A/T	– –
Galant	E54A	6A12-0 (2.0)	–	Four	X	–	MPI	F5M31-2 F4A23-2	5M/T 4A/T	– –
	E55A	4G63-6 (2.0)	X	Single	X	–	MPI	F5M22-2 F4A22-2	5M/T 4A/T	– –
Pajero/ Montero	V12W V32W	4G54-1 (2.6)	X	Single	X	–	CARB	V5M21-5	5M/T	X
	V23W	6G72-1 (3.0)	–	Single	X	–	MPI	V5MT1-3	5M/T	X
	V43W	6G72-1 (3.0)	–	Single	X	–	MPI	V5MT1-3 V4AW2-3	5M/T 3A/T	X X
	V34W	4D56-1 (2.5)	X	Single	–	X	Diesel	V5M21-5	5M/T	X
	V44W	4D56-1 (2.5)	X	Single	–	X	Diesel	V5MT1-3	5M/T	X
L200	K13T	4G54-1 (2.6)	X	Single	X	–	CARB	R5M21-1	5M/T	–
	K14T	4D56-1 (2.5)	X	Single	–	–	Diesel	R5M21-1	5M/T	–
L200 4WD	K33T	4G54-1 (2.6)	X	Single	X	–	CARB	R5M21-1	5M/T	X
	K34T	4D56-1 (2.5)	X	Single	–	X	Diesel	R5M21-1	5M/T	X
	K36T	6G72-1 (3.0)	–	Double	X	–	MPI	V5MT1-2	5M/T	X

AUSTRALIA for 1993

Brand	Vehicle model	Engine					Fuel system	Transmission		
		Model (lit.)	Silent shaft	Camshaft	Lash adjuster	Turbo charger		Model	Type	4WD
L300	P03V P03W	4G63-9 (2.0)	X	Single	X	–	CARB	R5M21-2 R4AW2-2	5M/T 4A/T	– –
	P04W P14V	4G64-3 (2.4)	X	Single	X	–	MPI	R5M21-2 R4AW2-2	5M/T 4A/T	– –
	P05V P15V	4D56-1 (2.5)	X	Single	–	–	Diesel S-QGS	R5M21-2 R4AW2-2	5M/T 4A/T	– –
L300 4WD	P24V P24W	4G64-3 (2.4)	X	Single	X	–	MPI	V5M21-2	5M/T	X
3000GT	Z16A	6G72-4 (3.0)	–	Four	X	X	MPI	W5MG1-1	5M/T	X

EUROPE for 1994

Brand	Vehicle model	Engine					Fuel system	Transmission		
		Model (lit.)	Silent shaft	Camshaft	Lash adjuster	Turbo charger		Model	Type	4WD
Colt	CA1A	4G13-2 (1.3)	–	Single	–	–	MPI	F5M21-1	5M/T	–
	CA4A	4G92-0 (1.6)	–	Single	–	–	MPI	F5M22-2 F4A22-2	5M/T 4A/T	– –
	CA5A	4G93-1 (1.8)	–	Double	X	–	MPI	F5M22-2	5M/T	–
	CC4A	4G92-0 (1.6)	–	Single	–	–	MPI	W5M31-2	5M/T	X
Lancer/ Lancer Wagon	CB1A	4G13-2 (1.3)	–	Single	–	–	MPI	F5M21-1	5M/T	–
	CB4A CB4W	4G92-0 (1.6)	–	Single	–	–	MPI	F5M22-2 F4A22-2	5M/T 4A/T	– –
	CB5A	4G93-1 (1.8)	–	Double	X	–	MPI	F5M22-2	5M/T	–
	CB8A CB8W	4D68-0 (2.0)	X	Single	–	–	Diesel S-RGS	F5M22-1	5M/T	–
	CD4A CD4W	4G92-0 (1.6)	–	Single	–	–	MPI	W5M31-2	5M/T	X
	C61A	4G13-2 (1.3)	–	Single	–	–	MPI	F5M21-1	5M/T	–
	C66A	4G92-0 (1.6)	–	Single	–	–	MPI	F5M22-2 F4A21-2	5M/T 4A/T	– –
	C67A	4D68-0 (2.0)	X	Single	–	–	Diesel S-RGS	F5M22-1	5M/T	–
	C69A	4G93-1 (1.8)	–	Double	X	–	MPI	F5M22-2	5M/T	–
	C76A	4G92-0 (1.6)	–	Single	–	–	MPI	W5M31-2	5M/T	X
Space Runner	N11W	4G93-0 (1.8)	–	Single	–	–	MPI	F5M22-1 F4A22-2	5M/T 4A/T	– –
	N18W	4D68-0 (2.0)	X	Single	–	X	Diesel S-RGS	F5M31-1	5M/T	–
	N21W	4G93-0 (1.8)	–	Single	–	–	MPI	W5M31-2	5M/T	X

EUROPE for 1994

Brand	Vehicle model	Engine					Fuel system	Transmission		
		Model (lit.)	Silent shaft	Camshaft	Lash adjuster	Turbo charger		Model	Type	4WD
Space Wagon	N33W	4G63-6 (2.0)	X	Single	X	–	MPI	F5M22-1 F4A22-2	5M/T 4A/T	– –
	N34W	4G64-2 (2.4)	X	Single	X	–	MPI	F5M22-1 F4A23-2	5M/T 4A/T	– –
	N38W	4D68-0 (2.0)	X	Single	–	X	Diesel S-RGS	F5M31-1	5M/T	–
	N43W	4G63-6 (2.0)	X	Single	X	–	MPI	W5M31-2 W4A32-1	5M/T 4A/T	X X
Galant	E52A	4G93-0 (1.8)	–	Single	–	–	MPI	F5M22-2 F4A22-2	5M/T 4A/T	– –
	E54A E64A	6A12-0 (2.0)	–	Four	X	–	MPI	F5M31-2 F4A23-2	5M/T 4A/T	– –
	E55A	4G63-6 (2.0)	X	Single	X	–	MPI	F5M22-2 F4A22-2	5M/T 4A/T	– –
	E57A	4D68-0 (2.0)	X	Single	–	X	Diesel S-RGS	F5M31-1	5M/T	–
	E75A	4G63-6 (2.0)	X	Single	X	–	MPI	W5M31-2	5M/T	X
	E88A	6G73-1 (2.5)	–	Four	X	–	MPI	W5M33-2	5M/T	X
	E99A	420B-0 (2.0)	–	Double	X	–	MPI	F5MC1-1 F4AC1-1	5M/T 4A/T	– –
Pajero/ Montero	V21W	4G64-3 (2.4)	X	Single	X	–	MPI	V5M21-6	5M/T	X
	V23C	6G72-1 (3.0)	–	Double	X	–	MPI	V4AW2-7	4A/T	X
	V23W V43W	6G72-1 (3.0)	–	Double	X	–	MPI	V5MT1-6 V4AW2-7	5M/T 4A/T	X X
	V24C V24W	4D56-1 (2.5)	X	Single	–	X	Diesel S-RGS	V5MT1-6	5M/T	X
	V25W V45W	6G74-1 (3.5)	–	Four	X	–	MPI	V5M31-5 V4AW3-7	5M/T 4A/T	X X
	V46W	4M40 (2.8)	X	Single	–	X	Diesel S-RGS	V5M31-5 V4AW3-7	5M/T 4A/T	X X
L200	K11T	4G32-8 (1.6)	–	Single	–	–	CARB	R5M21-1	5M/T	–
	K12T	4G63-9 (2.0)	X	Single	X	–	CARB	R5M21-1	5M/T	–
	K14T	4D56-1 (2.5)	X	Single	–	–	Diesel S-RGS	R5M21-1	5M/T	–

EUROPE for 1994

Brand	Vehicle model	Engine					Fuel system	Transmission		
		Model (lit.)	Silent shaft	Camshaft	Lash adjuster	Turbo charger		Model	Type	4WD
L200 4WD	K32T	4G63-9 (2.0)	X	Single	X	–	CARB	V5M21-1	5M/T	X
	K24T K34T	4D56-1 (2.5)	X	Single	–	X	Diesel S-RGS	V5M21-1	5M/T	X
	K34T	4D56-2 (2.5)	X	Single	–	X	Diesel S-RGS	V5M21-1	5M/T	X
	K33T	G54B-1 (2.6)	X	Single	X	–	ELEC. CARB	V5M21-1	5M/T	X
L300	P02V P12V	4G32-8 (1.6)	–	Single	–	–	CARB	R5M21-2	5M/T	–
	P03V	4G63-9 (2.0)	X	Single	X	–	ELEC. CARB	R5M21-2	5M/T	–
	P03W	4G63-9 (2.0)	X	Single	X	–	CARB	R5M21-2 R4AW2-2	5M/T 4A/T	– –
							ELEC. CARB	R5M21-2	5M/T	–
	P13V	4G63-9 (2.0)	X	Single	X	–	CARB	R5M21-2	5M/T	–
							ELEC. CARB	R5M21-2	5M/T	–
	P04V P04W P14V	4G64-3 (2.4)	X	Single	X	–	MPI	R5M21-2	5M/T	–
	P05V P05W P15V	4D56-1 (2.5)	X	Single	–	–	Diesel S-RGS	R5M21-2	5M/T	–
	P15V	4D56-2 (2.5)	X	Single	–	–	Diesel S-RGS	R5M21-2	5M/T	–
	L032P	4G32-8 (1.6)	–	Single	–	–	CARB	R5M21-3	5M/T	–
L039P	4D56-1 (2.5)	X	Single	–	–	Diesel S-RGS	R5M21-3	5M/T	–	
L300 4WD	P24V P24W	4G64-3 (2.4)	X	Single	X	–	MPI	V5M21-2	5M/T	X
	P25V P45V P25W	4D56-1 (2.5)	X	Single	–	X	Diesel S-RGS	V5M21-2	5M/T	X
		4D56-2 (2.5)	X	Single	–	X	Diesel S-RGS	V5M21-2	5M/T	X
3000GT	Z16A	6G72-4 (3.0)	–	Four	X	X	MPI	W5MG1-2	5M/T	X
Eclipse	D22A	4G63-7 (2.0)	X	Double	X	–	MPI	F5M31-2	5M/T	–
	D27A	4G63-7 (2.0)	X	Double	X	–	MPI	W5M33-2	5M/T	X

GENERAL EXPORT for 1994

Brand	Vehicle model	Engine					Fuel system	Transmission		
		Model (lit.)	Silent shaft	Camshaft	Lash adjuster	Turbo charger		Model	Type	4WD
Lancer/ Lancer Wagon	CB1A	4G13-2 (1.3)	-	Single	-	-	CARB	F5M21-1 F3A21-2	5M/T 3A/T	- -
							ELEC. CARB	F5M21-1 F3A21-2	5M/T 3A/T	- -
							MPI	F5M21-1	5M/T	-
	CB2A CB2W	4G15-2 (1.5)	-	Single	-	-	CARB	F5M21-1 F3A21-2	5M/T 3A/T	- -
	CB4A	4G92-0 (1.6)	-	Single	-	-	MPI	F5M22-2 F4A21-2 F4A22-2	5M/T 4A/T 4A/T	- - -
	CB8A	4D68-0 (2.0)	X	Single	-	-	Diesel S-RGS	F5M22-1	5M/T	-
	CB3A	4G91-1 (1.5)	-	Double	X	-	MPI	F5M21-1 F4A21-2	5M/T 4A/T	- -
	CB5A	4G93-1 (1.8)	-	Double	X	-	MPI	F5M22-2	5M/T	-
	CB1W	4G13-2 (1.3)	-	Single	-	-	CARB	F5M21-1 F3A21-2	5M/T 3A/T	- -
							ELEC. CARB	F5M21-1	5M/T	-
CB4W	4G92-0 (1.6)	-	Single	-	-	MPI	F5M22-2	5M/T	-	
Space Runner	N11W	4G93-0 (1.8)	-	Single	-	-	CARB	F5M22-1 F4A22-2	5M/T 4A/T	- -
							MPI	F5M22-1 F4A22-2	5M/T 4A/T	- -
Space Wagon	N31W	4G93-0 (1.8)	-	Single	-	-	CARB	F5M22-1 F4A22-2	5M/T 4A/T	- -
							MPI	F5M22-1 F4A22-2	5M/T 4A/T	- -
	N33W	4G63-6 (2.0)	X	Single	X	-	MPI	F5M22-1 F4A22-2	5M/T 4A/T	- -
Galant	E52A	4G93-0 (1.8)	-	Single	-	-	CARB	F5M22-2 F4A22-2	5M/T 4A/T	- -
							MPI	F5M22-2 F4A22-2	5M/T 4A/T	- -
	E54A	6A12-0 (2.0)	-	Four	X	-	MPI	F5M31-2 F4A23-2	5M/T 4A/T	- -
	E55A	4G63-6 (2.0)	X	Single	X	-	CARB	F5M22-2 F4A22-2	5M/T 4A/T	- -
MPI							F5M22-2 F4A22-2	5M/T 4A/T	- -	

GENERAL EXPORT for 1994

Brand	Vehicle model	Engine					Fuel system	Transmission		
		Model (lit.)	Silent shaft	Camshaft	Lash adjuster	Turbo charger		Model	Type	4WD
Pajero/ Montero	V12C	4G54-1 (2.6)	–	Single	–	–	CARB	V5M21-5 V4AW2-3	5M/T 4A/T	X X
	V32W	4G54-1 (2.6)	–	Single	–	–	CARB	V5M21-5	5M/T	X
	V14C V14V	4D56-1 (2.5)	X	Single	–	–	Diesel S-RGS	V5M21-6	5M/T	X
	V12V V12W V32V	4G54-1 (2.6)	–	Single	–	–	CARB	V5M21-6	5M/T	X
	V14V V24W	4D56-1 (2.5)	X	Single	–	X	Diesel S-RGS	V5M21-6	5M/T	X
	V25W V45W	6G74-1 (3.5)	–	Four	X	–	MPI	V5M31-5 V4AW3-7	5M/T 4A/T	X X
	V23W V43W	6G72-1 (3.0)	–	Double	X	–	MPI	V5MT1-6 V4AW2-7	5M/T 4A/T	X X
	V36V V36W	4M40 (2.8)	X	Single	–	–	Diesel S-RGS	V5M21-6	5M/T	X
	V46W	4M40 (2.8)	X	Single	–	X	Diesel S-RGS	V5M31-5 V4AW3-7	5M/T 4A/T	X X
L200	K01T K11T	4G32-8 (1.6)	–	Single	–	–	CARB	R4M21-1	4M/T	–
	K02T K12T	4G63-8 (2.0)	–	Single	–	–	CARB	R5M21-1	5M/T	–
	K03T K13T	4G54-1 (2.6)	–	Single	–	–	CARB	R5M21-1	5M/T	–
	K14T	4D56-1 (2.5)	X	Single	–	–	Diesel S-RGS	R5M21-1	5M/T	–
	K15T	4G64-3 (2.4)	X	Single	X	–	MPI	R5M21-1	5M/T	–
L200 4WD	K22T K32T	4G63-8 (2.0)	–	Single	–	–	CARB	V5M21-1	5M/T	X
	K24T K34T	4D56-1 (2.5)	X	Single	–	–	Diesel S-RGS	V5M21-1	5M/T	X
			X	Single	–	X	Diesel S-RGS	V5M21-1	5M/T	X
	K35T	4G64-3 (2.4)	X	Single	X	–	MPI	V5M21-1	5M/T	X

GENERAL EXPORT for 1994

Brand	Vehicle model	Engine					Fuel system	Transmission		
		Model (lit.)	Silent shaft	Camshaft	Lash adjuster	Turbo charger		Model	Type	4WD
L300	P01V	4G33-8 (1.4)	—	Single	—	—	CARB	R4M21-2	4M/T	—
		G33B-8 (1.4)	—	Single	—	—	CARB	R4M21-2	4M/T	—
	P01W	4G33-8 (1.4)	—	Single	—	—	CARB	R4M21-2	4M/T	—
	P12V P12W	4G32-8 (1.6)	—	Single	—	—	CARB	R4M21-2	4M/T	—
	P03V P13V P13W	4G63-8 (2.0)	—	Single	—	—	CARB	R5M21-2	5M/T	—
	P03W	4G63-8 (2.0)	—	Single	—	—	CARB	R5M21-2 R4AW2-2	5M/T 4A/T	— —
	P04W	4G64-3 (2.4)	X	Single	X	—	MPI	R4AW2-2	4A/T	—
	P14V	4G64-3 (2.4)	X	Single	X	—	MPI	R5M21-2	5M/T	—
	P05V P15V P15W	4D56-1 (2.5)	X	Single	—	—	Diesel S-RGS	R5M21-2	5M/T	—
	P05W	4D56-1 (2.5)	X	Single	—	—	Diesel S-RGS	R5M21-2	5M/T	—
L300 4WD	P23W	4G63-8 (2.0)	—	Single	—	—	CARB	V5M21-2	5M/T	X
	P24W	4G64-3 (2.4)	X	Single	X	—	MPI	V5M21-2	5M/T	X
Sigma	F16A	6G72-1 (3.0)	—	Double	X	—	MPI	F5M33-2 F4A33-1	5M/T 4A/T	— —
		6G72-4 (3.0)	—	Four	X	—	MPI	F5M33-2 F4A33-1	5M/T 4A/T	— —
Diamante	F26A	6G72-4 (3.0)	—	Four	X	—	MPI	W4A33-1	4A/T	X
3000GT	Z16A	6G72-4 (3.0)	—	Four	X	X	MPI	W6MG1-0	6M/T	X

AUSTRALIA for 1994

Brand	Vehicle model	Engine					Fuel system	Transmission		
		Model (lit.)	Silent shaft	Camshaft	Lash adjuster	Turbo charger		Model	Type	4WD
Space Wagon	N34W	4G64-2 (2.4)	X	Single	X	–	MPI	F5M31-2 F4A23-2	5M/T 4A/T	– –
Galant	E54A	6A12-0 (2.0)	–	Four	X	–	MPI	F5M31-2 F4A23-2	5M/T 4A/T	– –
	E55A	4G63-6 (2.0)	X	Single	X	–	MPI	F5M22-2 F4A22-2	5M/T 4A/T	– –
Pajero/ Montero	V23W V43W	6G72-1 (3.0)	–	Double	X	–	MPI	V5MT1-6 V4AW2-7	5M/T 4A/T	X X
	V36W	4M40 (2.8)	X	Single	–	–	Diesel S-RGS	V5M21-6	5M/T	X
	V46W	4M40 (2.8)	X	Single	–	X	Diesel S-RGS	V5M31-5	5M/T	X
	V45W	6G74-1 (3.5)	–	Four	X	–	MPI	V4AW3-7	4A/T	X
L200	K13T	4G54-1 (2.6)	X	Single	X	–	CARB	R5M21-1	5M/T	–
	K14T	4D56-1 (2.5)	X	Single	–	–	Diesel S-RGS	R5M21-1	5M/T	–
L200 4WD	K33T	4G54-1 (2.6)	X	Single	X	–	CARB	V5M21-1	5M/T	X
	K34T	4D56-1 (2.5)	X	Single	–	X	Diesel S-RGS	V5M21-1	5M/T	X
	K36T	6D72-1 (3.0)	–	Double	X	–	MPI	V5MT1-2	5M/T	X
L300	P03V P03W	4G63-9 (2.0)	X	Single	X	–	CARB	R5M21-2 R4AW2-2	5M/T 4A/T	– –
	P04W P14V	4G64-3 (2.4)	X	Single	X	–	MPI	R5M21-2 R4AW2-2	5M/T 4A/T	– –
	P05V P15V	4D56-1 (2.5)	X	Single	–	–	Diesel S-RGS	R5M21-2 R4AW2-2	5M/T 4A/T	– –
L300 4WD	P24V P24W	4G64-3 (2.4)	X	Single	X	–	MPI	V5M21-2	5M/T	X
3000GT	Z16A	6G72-4 (3.0)	–	Four	X	X	MPI	W6MG1-0	6M/T	X

EUROPE for 1995

Brand	Vehicle Model	Engine					Fuel System	Transmission		
		Model (lit.)	Silent shaft	Camshaft	Lash adjuster	Turbo charger		Model	Type	4WD
Colt	CA1A	4G13-2 (1.3)	-	Single	-	-	MPI	F5M21-1	5M/T	-
	CA4A	4G92-0 (1.6)	-	Single	-	-	MPI	F5M22-2 F4A22-2	5M/T 4A/T	- -
	CA5A	4G93-1 (1.8)	-	Double	x	-	MPI	F5M22-2	5M/T	-
	CC4A	4G92-0 (1.6)	-	Single	-	-	MPI	W5M31-2	5M/T	x
Lancer/ Lancer Wagon	CB1A	4G13-2 (1.3)	-	Single	-	-	MPI	F5M21-1	5M/T	-
	CB4A CB4W	4G92-0 (1.6)	-	Single	-	-	MPI	F5M22-2 F4A22-2	5M/T 4A/T	- -
	CB5A	4G93-1 (1.8)	-	Double	x	-	MPI	F5M22-2	5M/T	-
	CB8A CB8W	4D68-0 (2.0)	x	Single	-	-	Diesel S-RGS	F5M22-1	5M/T	-
	CD4W	4G92-1 (1.6)	-	Single	-	-	MPI	W5M31-2	5M/T	x
	C61A	4G13-2 (1.3)	-	Single	-	-	MPI	F5M21-1	5M/T	-
	C66A	4G92-0 (1.6)	-	Single	-	-	MPI	F5M22-2 F4A21-2	5M/T 4A/T	- -
	C67A	4D68-0 (2.0)	x	Single	-	-	Diesel S-RGS	F5M22-1	5M/T	-
	C69A	4G93-1 (1.8)	-	Double	x	-	MPI	F5M22-2	5M/T	-
	C76A	4G92-0 (1.6)	-	Single	-	-	MPI	W5M31-2	5M/T	x

EUROPE for 1995

Brand	Vehicle Model	Engine					Fuel System	Transmission		
		Model (lit.)	Silent shaft	Camshaft	Lash adjuster	Turbo charger		Model	Type	4WD
Space Runner	N11W	4G93-0 (1.8)	–	Single	–	–	MPI	F5M22-1 F4A22-2	5M/T 4A/T	– –
	N18W	4D68-0 (2.0)	×	Single	–	×	Diesel S-RGS	F5M31-1	5M/T	–
	N21W	4G93-0 (1.8)	–	Single	–	–	MPI	W5M31-2	5M/T	×
Space Wagon	N33W	4G63-6 (2.0)	×	Single	×	–	MPI	F5M22-1 F4A22-2	5M/T 4A/T	– –
	N34W	4G64-2 (2.4)	×	Single	×	–	MPI	F5M22-1 F4A32-2	5M/T 4A/T	– –
	N38W	4D68-0 (2.0)	×	Single	–	×	Diesel S-RGS	F5M31-1	5M/T	–
	N43W	4G63-6 (2.0)	×	Single	×	–	MPI	W5M31-2 W4A32-1	5M/T 4A/T	× ×
Galant	E52A	4G93-0 (1.8)	–	Single	–	–	MPI	F5M22-2 F4A22-2	5M/T 4A/T	– –
	E54A	6A12-0 (2.0)	–	Four	×	–	MPI	F5M31-2 F4A23-2	5M/T 4A/T	– –
	E55A	4G63-6 (2.0)	×	Single	×	–	MPI	F5M22-2 F4A22-2	5M/T 4A/T	– –
	E57A	4D68-0 (2.0)	×	Single	–	×	Diesel S-RGS	F5M31-1	5M/T	–
	E75A	4G63-6 (2.0)	×	Single	×	–	MPI	W5M31-2	5M/T	×
	E88A	6G73-1 (2.5)	–	Four	×	–	MPI	W5M33-2	5M/T	×
Sigma	F16A	6G72-1 (3.0)	–	Double	×	–	MPI	F5M33-2 F4A33-1	5M/T 4A/T	– –
	F16A	6G72-4 (3.0)	–	Four	×	–	MPI	F5M33-2 F4A33-1	5M/T 4A/T	– –

EUROPE for 1995

Brand	Vehicle Model	Engine					Fuel System	Transmission		
		Model (lit.)	Silent shaft	Camshaft	Lash adjuster	Turbo charger		Model	Type	4WD
Pajero/ Montero	V23C V23W V43W	6G72-1 (3.0)	–	Double	×	–	MPI	V5MT1-6 V4AW2-7	5M/T 4A/T	×
	V24C V24W V44W	4D56-2 (2.5)	×	Single	–	×	Diesel S-RGS	V5MT1-5	5M/T	×
	V25W V45W	6G74-1 (3.5)	–	Four	×	–	MPI	V5M31-5 V4AW3-7	5M/T 4A/T	×
	V46W	4M40 (2.8)	×	Single	–	×	Diesel S-RGS	V5M31-5 V4AW3-7	5M/T 4A/T	×
L200	K12T	4G63-9 (2.0)	×	Single	×	–	CARB	R5M21-1	5M/T	–
	K14T	4D56-2 (2.5)	×	Single	–	–	Diesel S-RGS	R5M21-1	5M/T	–
	K15T	4G64-3 (2.4)	×	Single	×	–	MPI	R5M21-1	5M/T	–
L200 4WD	K24T K34T	4D56-2 (2.5)	×	Single	–	–	Diesel S-RGS	V5M21-1	5M/T	×
	K35T	4G64-3 (2.4)	×	Single	×	–	MPI	V5M21-1	5M/T	×
	K33T	4G54-1 (2.6)	×	Single	×	–	ELEC CARB	V5M21-1	5M/T	×
L300	P03V P13V	4G63-9 (2.0)	×	Single	×	–	ELEC CARB	R5M21-2	5M/T	–
	P05V P15V	4D56-2 (2.5)	×	Single	–	–	Diesel S-RGS	R5M21-1	5M/T	–
L300 4WD	P25T P45T	4D56-2 (2.5)	×	Single	–	×	Diesel S-RGS	V5M21-1	5M/T	×

EUROPE for 1995

Brand	Vehicle Model	Engine					Fuel System	Transmission		
		Model (lit.)	Silent shaft	Camshaft	Lash adjuster	Turbo charger		Model	Type	4WD
L400	PA3V PB3V	4G63-A (2.0)	×	Single	×	–	ELEC CARB	R5M21-7	5M/T	–
	PA3V PB3V	4G63-6 (2.0)	×	Single	×	–	MPI	R5M21-7	5M/T	–
	PA5V PB5V	4D56-2 (2.5)	×	Single	–	×	Diesel S-RGS	R5M21-1	5M/T	–
	PD4V	4G64-2 (2.4)	×	Single	×	–	MPI	V5M21-7	5M/T	×
	PD5V	4D56-2 (2.5)	×	Single	–	×	Diesel S-RGS	V5M21-7	5M/T	×
	PA3W	4G63-6 (2.0)	×	Single	×	–	MPI	R5M21-7 R4AW2-5	5M/T 4A/T	– –
	PA4W	4G64-2 (2.4)	×	Single	×	–	MPI	R5M21-7 R4AW2-5	5M/T 4A/T	– –
	PA5W	4D56-2 (2.5)	×	Single	–	×	Diesel S-RGS	R5M31-7	5M/T	–
	PD4W	4G64-2 (2.4)	×	Single	×	–	MPI	V5M21-7	5M/T	×
	PD5W	4D56-2 (2.5)	×	Single	–	×	Diesel S-RGS	V5M31-7	5M/T	×
3000GT	Z16A	6G72-4 (3.0)	–	Four	×	×	MPI	W5MG1-2	5M/T	×
Eclipse	D22A	4G63-7 (2.0)	×	Double	×	–	MPI	F5M31-2	5M/T	–
	D27A	4G63-7 (2.0)	×	Double	×	–	MPI	W5M33-2	5M/T	×

GENERAL EXPORT for 1995

Brand	Vehicle Model	Engine					Fuel System	Transmission		
		Model (lit.)	Silent shaft	Camshaft	Lash adjuster	Turbo charger		Model	Type	4WD
Colt	CA1A	4G13-2 (1.3)	-	Single	-	-	CARB	F5M21-1	5M/T	-
	CA2A	4G15-2 (1.5)	-	Single	-	-	CARB	F5M21-1 F3A21-2	5M/T 3A/T	- -
	CA4A	4G92-0 (1.6)	-	Single	-	-	MPI	F5M22-2 F4A22-2	5M/T 4A/T	- -
	CA5A	4G93-0 (1.8)	-	Single	-	-	MPI	F5M22-2 F4A22-2	5M/T 4A/T	- -
	CA5A	4G93-1 (1.8)	-	Double	x	-	MPI	F5M22-2	5M/T	-
Lancer/ Lancer Wagon	CB1A	4G13-2 (1.3)	-	Single	-	-	CARB	F5M21-1	5M/T	-
	CB2A CB2W	4G15-2 (1.5)	-	Single	-	-	CARB	F5M21-1 F3A21-2	5M/T 3A/T	- -
	CB4A CB4W	4G92-0 (1.6)	-	Single	-	-	MPI	F5M22-2 F4A22-2	5M/T 4A/T	- -
	CB5A	4G93-1 (1.8)	-	Double	x	-	MPI	F5M22-2	5M/T	-
	CB8A CB8W	4D68-0 (2.0)	x	Single	-	-	Diesel S-RGS	F5M22-1	5M/T	-
	C62A	4G15-2 (1.5)	-	Single	-	-	CARB	F5M21-1	5M/T	-
	C66A	4G92-0 (1.6)	-	Single	-	-	MPI	F5M22-2 F4A21-2	5M/T 4A/T	-
Space Runner	N11W	4G93-0 (1.8)	-	Single	-	-	MPI	F5M22-1 F4A22-2	5M/T 4A/T	- -
Space Wagon	N31W	4G93-0 (1.8)	-	Single	-	-	MPI	F5M22-1 F4A22-2	5M/T 4A/T	- -
	N33W	4G63-6 (2.0)	x	Single	x	-	MPI	F5M22-1 F4A22-2	5M/T 4A/T	- -

GENERAL EXPORT for 1995

Brand	Vehicle Model	Engine					Fuel System	Transmission		
		Model (lit.)	Silent shaft	Camshaft	Lash adjuster	Turbo charger		Model	Type	4WD
Galant	E52A	4G93-0 (1.8)	-	Single	-	-	MPI CARB	F5M22-2	5M/T	-
								F4A22-2	4A/T	-
	E54A	6A12-0 (2.0)	-	Four	x	-	MPI	F5M31-2 F4A23-2	5M/T 4A/T	- -
	E55A	4G63-6 (2.0)	x	Single	x	-	MPI CARB	F5M22-2 F4A22-2	5M/T 4A/T	- -
Sigma	F16A	6G72-1 (3.0)	-	Double	x	-	MPI	F5M33-2 F4A33-1	5M/T 4A/T	- -
	F16A	6G72-4 (3.0)	-	Four	x	-	MPI	F5M33-2 F4A33-1	5M/T 4A/T	- -
Pajero/ Montero	V12V V12W V32V V32W	4G54-1 (2.6)	-	Single	-	-	CARB	V5M21-1	5M/T	x
	V13V V23W V33V V33W V43W	6G72-1 (3.0)	-	Double	x	-	MPI	V5MT1-6 V4AW2-7	5M/T 4A/T	x x
	V14C V14V V24W V34V V44W	4D56-2 (2.5)	x	Single	-	x	Diesel S-RGS	V5MT1-5	5M/T	x
	V25W V45W	6G74-1 (3.5)	-	Four	x	-	MPI	V5M31-5 V4AW3-7	5M/T 4A/T	x x
	V46W	4M40 (2.8)	x	Single	-	x	Diesel S-RGS	V5M31-5 V4AW3-7	5M/T 4A/T	x x

GENERAL EXPORT for 1995

Brand	Vehicle Model	Engine					Fuel System	Transmission		
		Model (lit.)	Silent shaft	Camshaft	Lash adjuster	Turbo charger		Model	Type	4WD
L200	K01T K11T	4G32-8 (1.6)	-	Single	-	-	CARB	R4M21-1	4M/T	-
	K02T K12T	4G63-9 (2.0)	×	Single	×	-	CARB	R5M21-1	5M/T	-
	K03T K13T	4G54-1 (2.6)	×	Single	×	-	CARB	R5M21-1	5M/T	-
	K14T	4D56-2 (2.5)	×	Single	-	-	Diesel S-RGS	R5M21-1	5M/T	-
	K15T	4G64-3 (2.4)	×	Single	×	-	MPI	R5M21-1	5M/T	-
L200 4WD	K22T K32T	4G63-9 (2.0)	×	Single	×	-	CARB	V5M21-1	5M/T	×
	K24T K34T	4D56-1 (2.5)	×	Single	-	-	Diesel S-RGS	V5M21-1	5M/T	×
	K35T	4G64-3 (2.4)	×	Single	×	-	MPI	V5M21-1	5M/T	×
L300	P03V P13V P13W	4G63-9 (2.0)	×	Single	×	-	CARB	R5M21-2	5M/T	-
	P15V P15W	4D56-2 (2.5)	×	Single	-	-	Diesel S-RGS	R5M21-1	5M/T	-
L300 4WD	P23W	4G63-9 (2.0)	×	Single	×	-	CARB	V5M21-2	5M/T	×

GENERAL EXPORT for 1995

Brand	Vehicle Model	Engine					Fuel System	Transmission		
		Model (lit.)	Silent shaft	Camshaft	Lash adjuster	Turbo charger		Model	Type	4WD
L400	PA3V PB3V	4G63-B (2.0)	×	Single	×	–	CARB ELECCARB	R5M21-7	5M/T	–
	PB4V	4G64-2 (2.4)	×	Single	×	–	MPI	R5M21-7	5M/T	–
	PB5V	4D56-2 (2.5)	×	Single	–	×	Diesel S-RGS	R5M21-1	5M/T	–
	PA3W PC3W	4G63-6 (2.0)	×	Single	×	–	CARB	R5M21-7 R4AW2-5	5M/T 4A/T	– –
	PA4W	4G64-2 (2.4)	×	Single	×	–	MPI	R4AW2-5	4M/T	–
	PA5W PC5W	4D56-2 (2.5)	×	Single	–	×	Diesel S-RGS	R5M31-7	5M/T	–
	PD3W	4G63-B (2.0)	×	Single	×	–	CARB	V5M21-7	5M/T	×
	PD4W	4G64-2 (2.4)	×	Single	×	–	MPI	V5M21-7	5M/T	×
3000GT	Z16A	6G72-4 (3.0)	–	Four	×	×	MPI	W5MG1-2	5M/T	×

AUSTRALIA for 1995

Brand	Vehicle Model	Engine					Fuel System	Transmission		
		Model (lit.)	Silent shaft	Camshaft	Lash adjuster	Turbo charger		Model	Type	4WD
Lancer/ Lancer Wagon	CA2A CB2A	4G15-2 (1.5)	-	Single	-	-	CARB	F5M21-1 F3A21-2	5M/T 3A/T	- -
	CB5W CA5A CB5A	4G93-0 (1.8)	-	Single	×	-	MPI	F5M22-2 F4A22-2	5M/T 4A/T	- -
	CD5A	4G93-1 (1.8)	-	Double	×	×	MPI	W5M33-2	5M/T	×
	C62A	4G15-2 (1.5)	-	Single	-	-	CARB	F5M21-1	5M/T	-
	C66A	4G92-0 (1.6)	-	Single	-	-	MPI	F5M22-2 F4A21-2	5M/T	-
Space Wagon	N34W	4G64-2 (2.4)	×	Single	×	-	MPI	F5M31-2 F4A23-2	5M/T 4A/T	- -
Galant	E54A	6A12-0 (2.0)	-	Four	×	-	MPI	F5M31-2 F4A23-2	5M/T 4A/T	- -
	E55A	4G63-6 (2.0)	×	Single	×	-	MPI	F5M22-2 F4A22-2	5M/T 4A/T	- -
Pajero/ Montero	V23W V43W	6G72-1 (3.0)	-	Double	×	-	MPI	V5MT1-6 V4AW2-7	5M/T 4A/T	×
	V45W	6G74-1 (3.5)	-	Four	×	-	MPI	V4AW3-7	4A/T	×
	V36W V46W	4M40 (2.8)	×	Single	-	×	Diesel S-RGS	V5M31-6	5M/T	×

AUSTRALIA for 1995

Brand	Vehicle Model	Engine					Fuel System	Transmission		
		Model (lit.)	Silent shaft	Camshaft	Lash adjuster	Turbo charger		Model	Type	4WD
L200	K13T	4G54-1 (2.6)	×	Single	×	–	CARB	R5M21-1	5M/T	–
	K14T	4D56-2 (2.5)	×	Single	–	–	Diesel S-RGS	R5M21-1	5M/T	–
L200 4WD	K33T	4G54-1 (2.6)	×	Single	×	–	CARB	V5M21-1	5M/T	×
	K34T	4D56-1 (2.5)	×	Single	–	–	Diesel S-RGS	V5M21-1	5M/T	×
	K35T	4G64-3 (2.4)	×	Single	×	–	MPI	V5M21-1	5M/T	×
L300	P03V	4G63-A (2.0)	×	Single	×	–	CARB	R5M21-2 R4AW2-8	5M/T 4A/T	– –
	P14V	4G64-2 (2.4)	×	Single	×	–	MPI	R5M21-2 R4AW2-8	5M/T 4A/T	– –
	P05V P15V	4D56-1 (2.5)	×	Single	–	–	Diesel S-RGS	R5M21-1 R4AW2-8	5M/T 4A/T	– –
L300 4WD	P24V	4G64-2 (2.4)	×	Single	×	–	MPI	V5M21-2 V4AW2-5	5M/T 4A/T	×
L400	PA3W	4G63-B (2.0)	×	Single	×	–	CARB	R5M21-7 R4AW2-8	5M/T 4A/T	– –
	PB4V PB4W	4G64-2 (2.4)	×	Single	×	–	MPI	R5M21-7 R4AW2-8	5M/T 4A/T	– –
	PB6W	6G72-8 (3.0)	–	Double	×	–	MPI	R4AW3-5	4A/T	–
3000GT	Z16A	6G72-4 (3.0)	–	Four	×	×	MPI	W5MG1-2	5M/T	×

EUROPE for 1996

Brand	Vehicle Model	Engine					Fuel System	Transmission		
		Model (lit.)	Silent shaft	Camshaft	Lash adjuster	Turbo charger		Model	Type	4WD
Colt	CJ1A	4G13-3 (1.3)	-	Single	-	-	MPI	F5M41-1 F4A41-1	5M/T 4A/T	- -
		4G92-3 (1.6)	-	Single	-	-	MPI	F5M41-1 F4A41-1	5M/T 4A/T	- -
	4G92-8 (1.6)	-	Single	-	-	MPI	F5M41-1	5M/T	-	
Lancer	CB4W	4G92-0 (1.6)	-	Single	-	-	MPI	F5M22-2 F4A22-2	5M/T 4M/T	- -
	CD4W	4G92-0 (1.6)	-	Single	-	-	MPI	W5M31-2	4M/T	x
	CK1A	4G13-3 (1.3)	-	Single	-	-	MPI	F5M41-1 F4A41-1	5M/T 4A/T	- -
	CK4A	4G92-3 (1.6)	-	Single	-	-	MPI	F5M41-1 F4A41-1	5M/T 4A/T	- -
Carisma	DA1A	4G92-2 (1.6)	-	Single	-	-	MPI	F5MR1 F4A41-1	5M/T 4A/T	- -
	DA2A	4G93-2 (1.8)	-	Single	-	-	MPI	F5MR1 F4A42-1	5M/T 4A/T	- -
		4G93-4 (1.8)	-	Double	x	-	MPI	F5MR1	5M/T	-
Space Runner	N11W	4G93-0 (1.8)	-	Single	-	-	MPI	F5M22-1 F4A22-2	5M/T 4A/T	- -
	N18W	4D68-0 (2.0)	x	Single	-	x	Diesel S-RGS	F5M31-1	5M/T	-
	N21W	4G93-0 (1.8)	-	Single	-	-	MPI	W5M31-2	5M/T	x
Space Wagon	N33W	4G63-6 (2.0)	x	Single	x	-	MPI	F5M22-1 F4A22-2	5M/T 4A/T	- -
	N34W	4G64-2 (2.4)	x	Single	x	-	MPI	F5M22-1 F4A23-2	5M/T 4A/T	- -
	N38W	4D68-0 (2.0)	x	Single	-	x	Diesel S-RGS	F5M31-1	5M/T	-

EUROPE for 1996

Brand	Vehicle Model	Engine					Fuel System	Transmission		
		Model (lit.)	Silent shaft	Camshaft	Lash adjuster	Turbo charger		Model	Type	4WD
Space Wagon	N43W	4G63-6 (2.0)	×	Single	×	–	MPI	W5M31-2	5M/T	×
								W4A32-1	4A/T	×
Galant	E52A	4G93-0 (1.8)	–	Single	–	–	MPI	F5M22-2 F4A22-2	5M/T 4A/T	– –
	E54A	6A12-0 (2.0)	–	Four	×	–	MPI	F5M31-2 F4A23-2	5M/T 4A/T	– –
	E55A	4G63-6 (2.0)	×	Single	×	–	MPI	F5M22-2 F4A22-2	5M/T 4A/T	– –
	E57A	4D68-0 (2.0)	×	Single	–	×	Diesel S-RGS	F5M31-2	5M/T	–
	E75A	4G63-6 (2.0)	×	Single	×	–	MPI	W5M31-2	5M/T	×
	E88A	6G73-1 (2.5)	–	Four	×	–	MPI	W5M33-2	5M/T	×
	Pajero/ Montero	V23C V23W V43W	6G72-8 (3.0)	–	Double	×	–	MPI	V5MT1-6 V4AW3-7	5M/T 4A/T
V24C V24W V44W		4D56-2 (2.5)	×	Single	–	×	Diesel S-RGS	V5MT1-6	5M/T	×
V25W V45W		6G74-1 (3.5)	–	Four	×	–	MPI	V5M31-5 V4AW3-7	5M/T 4A/T	×
V26W V46W		4M40 (2.8)	×	Single	–	×	Diesel S-RGS	V5M31-5 V4AW3-7	5M/T 4A/T	×
L200	K14T	4D56-2 (2.5)	×	Single	–	–	Diesel S-RGS	R5M21-1	5M/T	–
	K15T	4G64-3 (2.4)	×	Single	×	–	MPI	R5M21-1	5M/T	–
L200 4WD	K24T K34T	4D56-2 (2.5)	×	Single	–	×	Diesel S-RGS	V5M21-1	5M/T	×
	K35T	4G64-3 (2.4)	×	Single	×	–	MPI	V5M21-1	5M/T	×

EUROPE for 1996

Brand	Vehicle Model	Engine					Fuel System	Transmission		
		Model (lit.)	Silent shaft	Camshaft	Lash adjuster	Turbo charger		Model	Type	4WD
L300	P03V P13V	4G63-6 (2.0)	×	Single	×	–	MPI	R5M21-2	5M/T	–
	P05V P05W P15V	4D56-2 (2.5)	×	Single	–	–	Diesel S-RGS	R5M21-2	5M/T	–
	P04W	4G64-3 (2.4)	×	Single	×	–	MPI	R5M21-2	5M/T	–
	P13T	4G63-6 (2.0)	×	Single	×	–	MPI	R5M21-8	5M/T	–
	P15T	4D56-2 (2.5)	×	Single	–	×	Diesel S-RGS	R5M21-8	5M/T	–
L300 4WD	P25V P25W P45V	4D56-2 (2.5)	×	Single	–	×	Diesel S-RGS	V5M21-2	5M/T	×
L400	PA3V PB3V	4G63-6 (2.0)	×	Single	×	–	MPI	R5M21-7	5M/T	–
	PA5V PB5V	4D56-2 (2.5)	×	Single	–	×	Diesel S-RGS	R5M21-7	5M/T	–
	PA3W	4G63-6 (2.0)	×	Single	×	–	MPI	R5M21-7 R4AW2-5	5M/T 4A/T	– –
	PA4W	4G64-2 (2.4)	×	Single	×	–	MPI	R5M21-7 R4AW2-5	5M/T 4A/T	– –
	PA5W	4D56-2 (2.5)	×	Single	–	×	Diesel S-RGS	R5M31-7	5M/T	–
	PD4V PD4W	4G64-2 (2.4)	×	Single	×	–	MPI	V5M21-7	5M/T	×
	PD5V	4D56-2 (2.5)	×	Single	–	×	Diesel S-RGS	V5M21-7	5M/T	×
	PD5W	4D56-2 (2.5)	×	Single	–	×	Diesel S-RGS	V5M31-7	5M/T	×

EUROPE for 1996

Brand	Vehicle Model	Engine					Fuel System	Transmission		
		Model (lit.)	Silent shaft	Camshaft	Lash adjuster	Turbo charger		Model	Type	4WD
3000GT	Z16A	6G72-4 (3.0)	–	Four	×	×	MPI	W6MG1-0	6M/T	×
								W5MG1-3	5M/T	×
Eclipse	D32A	4G63-7 (2.0)	×	Double	×	–	MPI	F5M31-2	5M/T	–

GENERAL EXPORT for 1996

Brand	Vehicle Model	Engine					Fuel System	Transmission		
		Model (lit.)	Silent shaft	Camshaft	Lash adjuster	Turbo charger		Model	Type	4WD
Colt	CA1A	4G13-2 (1.3)	-	Single	-	-	CARB	F5M21-1	5M/T	-
	CA2A	4G15-2 (1.5)	-	Single	-	-	CARB	F5M21-1 F3A21-2	5M/T 3A/T	- -
	CA5A	4G93-1 (1.8)	-	Double	x	-	MPI	F5M22-2	5M/T	-
	CJ1A	4G13-5 (1.3)	-	Single	-	-	CARB	F5M41-1	5M/T	-
		4G13-3 (1.3)	-	Single	-	-	MPI	F5M41-1	5M/T	-
	CJ2A	4G15-5 (1.5)	-	Single	-	-	CARB	F5M41-1 F4A41-1	5M/T 4A/T	- -
	CJ4A	4G92-3 (1.6)	-	Single	-	-	MPI	F5M41-1 F4A41-1	5M/T 4A/T	- -
	CJ5A	4G93-5 (1.8)	-	Double	x	-	MPI	F5M42-1	5M/T	-
Lancer/ Lancer Wagon	CB1A	4G13-2 (1.3)	-	Single	-	-	CARB	F5M21-1	5M/T	-
	CB1W	4G13-2 (1.3)	-	Single	-	-	CARB	F5M21-1 F3A21-2	5M/T 3A/T	- -
	CB2A CB2W	4G15-2 (1.5)	-	Single	-	-	CARB	F5M21-1 F3A21-2	5M/T 3A/T	- -
	CK1A	4G13-5 (1.3)	-	Single	-	-	CARB	F5M41-1 F4A41-1	5M/T 4A/T	- -
		4G13-3 (1.3)	-	Single	-	-	MPI	F5M41-1 F4A41-1	5M/T 4A/T	- -
	CK2A	4G15-5 (1.5)	-	Single	-	-	CARB	F5M41-1 F4A41-1	5M/T 4A/T	- -
		4G15-4 (1.5)	-	Double	x	-	MPI	F5M41-1 F4A41-1	5M/T 4A/T	- -

GENERAL EXPORT for 1996

Brand	Vehicle Model	Engine					Fuel System	Transmission		
		Model (lit.)	Silent shaft	Camshaft	Lash adjuster	Turbo charger		Model	Type	4WD
Lancer/ Lancer Wagon	CK4A	4G92-3 (1.6)	–	Single	–	–	MPI	F5M41-1 F4A41-1	5M/T 4A/T	– –
		4G92-7 (1.6)	–	Double	–	–	MPI	F5M42-1 F4A42-1	5M/T 4A/T	– –
Space Runner	N11W	4G93-0 (1.8)	–	Single	–	–	MPI	F5M22-1 F4A22-2	5M/T 4A/T	– –
Space Wagon	N31W	4G93-0 (1.8)	–	Single	–	–	CARB	F5M22-1 F4A22-2	5M/T 4A/T	– –
	N33W	4G63-6 (2.0)	×	Single	×	–	MPI	F5M22-1 F4A22-2	5M/T 4A/T	– –
Galant	E52A	4G93-0 (1.8)	–	Single	–	–	CARB	F5M22-2 F4A22-2	5M/T 4A/T	– –
							MPI	F5M22-2 F4A22-2	5M/T 4A/T	– –
	E54A	6A12-0 (2.0)	–	Four	×	–	MPI	F5M31-2 F4A23-2	5M/T 4A/T	– –
	E55A	4G63-6 (2.0)	×	Single	×	–	CARB	F5M22-2 F4A22-2	5M/T 4A/T	– –
							MPI	F5M22-2 F4A22-2	5M/T 4A/T	– –
			4G63-D (2.0)	×	Single	×	–	CARB	F5M22-2 F4A22-2	5M/T 4A/T
Sigma	F16A	6G72-1 (3.0)	–	Double	×	–	MPI	F5M33-2 F4A33-1	5M/T 4A/T	– –
		6G72-4 (3.0)	–	Four	×	–	MPI	F5M33-2 F4A33-1	5M/T 4A/T	– –
Pajero/ Montero	V12V V12W V32V	4G54-1 (2.6)	–	Single	–	–	CARB	V5M21-6	5M/T	×
	V32W	4G54-1 (2.6)	–	Single	–	–	CARB	V5M21-6 V4AW2-7	5M/T 4A/T	× ×
	V13V V33V	6G72-1 (3.0)	–	Double	×	–	MPI	V5MT1-6	5M/T	×

GENERAL EXPORT for 1996

Brand	Vehicle Model	Engine					Fuel System	Transmission		
		Model (lit.)	Silent shaft	Camshaft	Lash adjuster	Turbo charger		Model	Type	4WD
Pajero/ Montero	V23W V43W	6G72-1 (3.0)	-	Double	x	-	MPI	V5MT1-6 V4AW2-7	5M/T 4A/T	x x
	V14C V14V V34V	4D56-2 (2.5)	x	Single	-	-	Diesel S-RGS	V5M21-6	5M/T	x
	V24W	4D56-2 (2.5)	x	Single	-	x	Diesel S-RGS	V5MT1-6	5M/T	x
	V44W	4D56-2 (2.5)	x	Single	-	x	Diesel S-RGS	V5MT1-6 V4AW2-7	5M/T 4A/T	x x
	V25W V45W	6G74-1 (3.5)	-	Four	x	-	MPI	V5M31-5 V4AW3-7	5M/T 4A/T	x x
	V36V V36W	4M40 (2.8)	x	Single	-	-	Diesel S-RGS	V5M31-5	5M/T	x
	V46W	4M40 (2.8)	x	Single	-	x	Diesel S-RGS	V5M31-5 V4AW3-7	5M/T 4A/T	x x
L200	K11T	4G32-8 (1.6)	-	Single	-	-	CARB	R4M21-1	4M/T	-
	K02T K12T	4G63-8 (2.0)	-	Single	-	-	CARB	R5M21-1	5M/T	-
	K03T K13T	4G54-1 (2.6)	-	Single	-	-	CARB	R5M21-1	5M/T	-
	K14T	4D56-2 (2.5)	x	Single	-	-	Diesel S-RGS	R5M21-1	5M/T	-
	K15T	4G64-3 (2.4)	x	Single	x	-	MPI	R5M21-1	5M/T	-
L200 4WD	K24T	4D56-2 (2.5)	x	Single	-	-	Diesel S-RGS	V5M21-1	5M/T	x
	K34T	4D56-2 (2.5)	x	Single	-	-	Diesel S-RGS	V5M21-1	5M/T	x
							x	Diesel S-RGS	V5M21-1	5M/T

GENERAL EXPORT for 1996

Brand	Vehicle Model	Engine					Fuel System	Transmission		
		Model (lit.)	Silent shaft	Camshaft	Lash adjuster	Turbo charger		Model	Type	4WD
L200 4WD	K32T	4G63-8 (2.0)	–	Single	–	–	CARB	V5M21-1	5M/T	×
	K35T	4G64-3 (2.4)	×	Single	×	–	MPI	V5M21-1	5M/T	×
L300	P03V P13W	4G63-B (2.0)	–	Single	×	–	CARB	R5M21-2	5M/T	–
	P13V	4G63-B (2.0)	–	Single	×	–	CARB	R5M21-2	5M/T	–
		4G63-6 (2.0)	×	Single	×	–	MPI	R5M21-2	5M/T	–
	P03W	4G63-8 (2.0)	–	Single	–	–	CARB	R5M21-2	5M/T	–
	P15V P15W	4D56-2 (2.5)	×	Single	–	–	Diesel S-RGS	R5M21-2	5M/T	–
	P06V P16V	4G92-0 (1.6)	–	Single	–	–	CARB	R5M21-2	5M/T	–
ELEC CARB							R5M21-2	5M/T	–	
L300 4WD	P23W	4G63-8 (2.0)	–	Single	–	–	CARB	V5M21-2	5M/T	×
		4G63-B (2.0)	–	Single	×	–	CARB	V5M21-2	5M/T	×
L400	PA3V PB3V	4G63-B (2.0)	–	Single	×	–	CARB	R5M21-7	5M/T	–
		4G63-A (2.0)	×	Single	×	–	ELEC CARB	R5M21-7	5M/T	–
	PA3W	4G63-B (2.0)	–	Single	×	–	CARB	R5M21-7 R4AW2-5	5M/T 4A/T	– –
		4G63-6 (2.0)	×	Single	×	–	MPI	R5M21-7	5M/T	–

GENERAL EXPORT for 1996

Brand	Vehicle Model	Engine					Fuel System	Transmission		
		Model (lit.)	Silent shaft	Camshaft	Lash adjuster	Turbo charger		Model	Type	4WD
L400	PB4V	4G64-2 (2.4)	×	Single	×	–	MPI	R5M21-7	5M/T	–
	PA4W	4G64-2 (2.4)	×	Single	×	–	MPI	R4AW2-5	4A/T	–
	PC3W	4G63-B (2.0)	–	Single	×	–	CARB	R5M21-7	5M/T	–
	PB5V	4D56-2 (2.5)	×	Single	–	×	Diesel S-RGS	R5M21-7	5M/T	–
	PA5W PC5W	4D56-2 (2.5)	×	Single	–	×	Diesel S-RGS	R5M21-7 R4AW2-5	5M/T 4A/T	– –
	PD3W	4G63-B (2.0)	–	Single	×	–	CARB	V5M21-7	5M/T	×
	PD4W	4G64-2 (2.4)	×	Single	×	–	MPI	V5M21-7	5M/T	×
	PD5W	4D56-2 (2.5)	×	Single	–	×	Diesel S-RGS	V5M21-7	5M/T	×
3000GT	Z16A	6G72-4 (3.0)	–	Four	×	×	MPI	W5MG1-2	5M/T	×

AUSTRALIA for 1996

Brand	Vehicle Model	Engine					Fuel System	Transmission		
		Model (lit.)	Silent shaft	Camshaft	Lash adjuster	Turbo charger		Model	Type	4WD
Lancer/ Lancer Wagon	CA2A CB2A	4G15-2 (1.5)	-	Single	-	-	CARB	F5M21-1 F3A21-2	5M/T 3A/T	- -
	CA5A CB5A CB5W	4G93-0 (1.8)	-	Single	-	-	MPI	F5M22-2 F4A22-2	5M/T 4A/T	- -
Space Wagon	N34W	4G64-2 (2.4)	x	Single	x	-	MPI	F5M31-2 F4A23-2	5M/T 4A/T	- -
Galant	E54A	6A12-0 (2.0)	-	Four	x	-	MPI	F5M31-2 F4A23-2	5M/T 4A/T	- -
	E55A	4G63-6 (2.0)	x	Single	x	-	MPI	F5M31-2 F4A23-2	5M/T 4A/T	- -
Pajero/ Montero	V23W V43W	6G72-1 (3.0)	-	Double	x	-	MPI	V5MT1-6 V4AW2-7	5M/T 4A/T	x x
	V36W	4M40 (2.8)	x	Single	-	x	Diesel S-RGS	V5M21-6	5M/T	x
	V46W	4M40 (2.8)	x	Single	-	x	Diesel S-RGS	V5M31-5	5M/T	x
	V45W	6G74-1 (3.5)	-	Four	x	-	MPI	F4AW3-7	4A/T	-
L200	K13T	4G54-1 (2.6)	x	Single	x	-	CARB	R5M21-1	5M/T	-
	K14T	4D56-2 (2.5)	x	Single	-	-	Diesel S-RGS	R5M21-1	5M/T	-
L200 4WD	K33T	4G54-1 (2.6)	-	Single	-	-	CARB	V5M21-1	5M/T	x
	K34T	4D56-2 (2.5)	x	Single	-	x	Diesel S-RGS	V5M21-1	5M/T	x
	K36T	6G72-1 (3.0)	-	Single	x	-	MPI	V5MT1-2	5M/T	x

AUSTRALIA for 1996

Brand	Vehicle Model	Engine					Fuel System	Transmission		
		Model (lit.)	Silent shaft	Camshaft	Lash adjuster	Turbo charger		Model	Type	4WD
L300	P03V	4G63-9 (2.0)	×	Single	×	–	CARB	R5M21-2 R4AW2-2	5M/T 4A/T	– –
		4G63-A (2.0)	×	Single	×	–	CARB	R5M21-2 R4AW2-8	5M/T 4A/T	– –
	P03W	4G63-9 (2.0)	×	Single	×	–	CARB	R5M21-2 R4AW2-2	5M/T 4A/T	– –
	P05V P15V	4D56-2 (2.5)	×	Single	–	–	Diesel S-RGS	R5M21-5 R4AW2-8	5M/T 4A/T	– –
	P14V	4G64-2 (2.4)	×	Single	×	–	MPI	R5M21-2 R4AW2-8	5M/T 4A/T	– –
L300 4WD	P24V	4G64-2 (2.4)	×	Single	×	–	MPI	V5M21-2	5M/T	×
L400	PB4V PA4W	4G64-2 (2.4)	×	Single	×	–	MPI	R5M21-7 R4AW2-5	5M/T 4A/T	– –
	PA3W	4G63-A (2.0)	×	Single	×	–	CARB	R5M21-7 R4AW2-5	5M/T 4A/T	– –
	PB6W	6G72-8 (3.0)	–	Double	×	–	MPI	R4AW3-5	4A/T	–
3000GT	Z16A	6G72-4 (3.0)	–	Four	×	×	MPI	W5MG1-2	5M/T	×

EUROPE for 1997

Brand	Vehicle Model	Engine					Fuel System	Transmission		
		Model (lit.)	Silent shaft	Camshaft	Lash adjuster	Turbo charger		Model	Type	4WD
Colt	CJ1A	4G13-3 (1.3)	-	Single	-	-	MPI	F5M41-1	5M/T	-
								F4A41-1	4A/T	-
	CJ4A	4G92-3 (1.6)	-	Single	-	-	MPI	F5M41-1 F4A41-1	5M/T 4A/T	- -
		4G92-8 (1.6)	-	Single	-	-	MPI	F5M41-1	5M/T	-
Lancer	CB4W	4G92-0 (1.6)	-	Single	-	-	MPI	F5M22-2 F4A22-2	5M/T 4A/T	- -
	CD4W	4G92-0 (1.6)	-	Single	-	-	MPI	W5M31-2	4A/T	×
	CK1A	4G13-3 (1.3)	-	Single	-	-	MPI	F5M41-1 F4A41-1	5M/T 4A/T	- -
	CK4A	4G92-3 (1.6)	-	Single	-	-	MPI	F5M41-1 F4A41-1	5M/T 4A/T	- -
Carisma	DA1A	4G92-2 (1.6)	-	Single	-	-	MPI	F5MR1 F4A42-1	5M/T 4A/T	- -
	DA2A	4G93-2 (1.8)	-	Single	-	-	MPI	F5MR1 F4A42-1	5M/T 4A/T	- -
		4G93-4 (1.8)	-	Double	×	-	MPI	F5MR1	5M/T	-
	DA4A	F8QT (1.8)	-	Single	-	-	MPI	F5MR1	5M/T	-
Space Runner	N11W	4G93-0 (1.8)	-	Single	-	-	MPI	F5M22-1 F4A22-2	5M/T 4A/T	- -
	N18W	4D68-0 (2.0)	×	Single	-	×	Diesel S-RGS	F5M31-1	5M/T	-
	N21W	4G93-0 (1.8)	-	Single	-	-	MPI	W5M31-2	5M/T	×
Space Wagon	N33W	4G63-6 (2.0)	×	Single	×	-	MPI	F5M22-1 F4A22-2	5M/T 4A/T	- -

EUROPE for 1997

Brand	Vehicle Model	Engine					Fuel System	Transmission		
		Model (lit.)	Silent shaft	Camshaft	Lash adjuster	Turbo charger		Model	Type	4WD
Space Wagon	N34W	4G64-2 (2.4)	×	Single	×	–	MPI	F5M22-1 F4A23-2	5M/T 4A/T	– –
	N38W	4D68-0 (2.0)	×	Single	×	–	Diesel S-RGS	F5M31-1	5M/T	–
	N43W	4G63-6 (2.0)	×	Single	–	×	MPI	W5M31-2 W4A32-1	5M/T 4A/T	×
GALANT	EA2A EA2W	4G63-6 (2.0)	×	Single	×	–	MPI	F5M42-1 F4A42-1	5M/T 4A/T	– –
	EA5A EA5W	6A13-4 (2.5)	–	Double	×	–	MPI	F5M42-2 F4A42-2	5M/T 4A/T	– –
	EA6A EA6W	4D68-4 (2.0)	×	Single	–	×	Diesel S-RGS	F5M42-2 F4A42-2	5M/T 4A/T	– –
Pajero/ Montero	V23C V23W V43W	6G72-8 (3.0)	–	Double	×	–	MPI	V5MT1-6 V4AW3-7	5M/T 4A/T	×
	V24C V24W V44W	4D56-2 (2.5)	×	Single	–	×	Diesel S-RGS	V5MT1-6	5M/T	×
	V25W V45W	6G74-1 (3.5)	–	Four	×	–	MPI	V5M31-5 V4AW3-7	5M/T 4A/T	×
	V26W V46W	4M40 (2.8)	×	Single	–	×	Diesel S-RGS	V5M31-5 V4AW3-7	5M/T 4A/T	×
L200	K14T	4D56-2 (2.5)	×	Single	–	–	Diesel S-RGS	R5M21-1	5M/T	–
	K15T	4G64-3 (2.4)	×	Single	×	–	MPI	R5M21-1	5M/T	–
	K24T K34T	4D56-2 (2.5)	×	Single	–	×	Diesel S-RGS	V5M21-1	5M/T	×
	K35T	4D64-3 (2.4)	×	Single	×	–	MPI	V5M21-1	5M/T	×
	K62T	4G63-6 (2.0)	×	Single	×	–	MPI	R5M21-5 R4AW2-6	5M/T 4A/T	– –

EUROPE for 1997

Brand	Vehicle Model	Engine					Fuel System	Transmission		
		Model (lit.)	Silent shaft	Camshaft	Lash adjuster	Turbo charger		Model	Type	4WD
L200	K64T	4D56-3 (2.5)	×	Single	–	×	Diesel S-RGS	R5M21-5	5M/T	–
	K75T	4G64-2 (2.4)	×	Single	×	–	MPI	V5M21-9	5M/T	×
	K74T	4D56-3 (2.5)	×	Single	–	×	Diesel S-RGS	V5MT1-4 V4AW2-6	5M/T 4A/T	×
L300	P03V P03W P13T P13V	4G63-6 (2.0)	×	Single	×	–	MPI	R5M21-8	5M/T	–
	P05V P05W P15T P15V	4D56-2 (2.5)	×	Single	–	×	Diesel S-RGS	R5M21-8	5M/T	–
	P25V P45V	4D56-2 (2.5)	×	Single	–	×	Diesel S-RGS	V5M21-8	5M/T	×
L400	PA3V PB3V	4G63-6 (2.0)	×	Single	×	–	MPI	R5M21-7	5M/T	–
	PA5V PB5V	4D56-2 (2.5)	×	Single	–	×	Diesel S-RGS	R5M21-7	5M/T	–
	PD4V	4G64-2 (2.4)	×	Single	×	–	MPI	V5M21-7	5M/T	×
	PD5V	4D56-2 (2.5)	×	Single	–	×	Diesel S-RGS	V5M21-7	5M/T	×
Space Gear	PA3W	4G63-6 (2.0)	×	Single	×	–	MPI	R5M21-7 R4AW2-5	5M/T	–
	PA4W	4G64-2 (2.4)	×	Single	×	–	MPI	R5M21-7 R4AW2-5	5M/T 4A/T	–
	PA5W	4D56-2 (2.5)	×	Single	–	×	Diesel S-RGS	R5M31-7	5M/T	–

EUROPE for 1997

Brand	Vehicle Model	Engine					Fuel System	Transmission		
		Model (lit.)	Silent shaft	Camshaft	Lash adjuster	Turbo charger		Model	Type	4WD
Space Gear	PD4W	6G64-2 (2.4)	×	Single	×	–	MPI	V5M21-7	5M/T	×
	PD5W	4D56-2 (2.5)	×	Single	–	×	Diesel S-RGS	V5M31-7	5M/T	×
3000GT	Z16A	6G72-4 (3.0)	–	Four	×	×	MPI	W6MG1-0	6M/T	×
Eclipse	D32A	4G63-7 (2.0)	×	Double	×	–	MPI	F5M31-2	5M/T	–

GENERAL EXPORT for 1997

Brand	Vehicle Model	Engine					Fuel System	Transmission		
		Model (lit.)	Silent shaft	Camshaft	Lash adjuster	Turbo charger		Model	Type	4WD
Colt	CJ1A	4G13-3 (1.3)	–	Single	–	–	CARB	F5M41-1	5M/T	–
		4G13-3 (1.3)	–	Single	–	–	MPI	F5M41-1	5M/T	–
	CJ2A	4G15-5 (1.5)	–	Single	–	–	CARB	F5M41-1	5M/T	–
	CJ4A	4G92-3 (1.6)	–	Single	–	–	MPI	F5M41-1 F4A41-1	5M/T 4A/T	– –
Lancer	CB1W	4G13-2 (1.3)	–	Single	–	–	CARB	F5M21-1 F3A21-2	5M/T 3A/T	– –
	CB2W	4G15-2 (1.5)	–	Single	–	–	CARB	F5M21-1 F3A21-2	5M/T 3A/T	– –
	CB4W	4G92-0 (1.6)	–	Single	–	–	MPI	F5M22-2 F4A22-2	5M/T 4A/T	– –
	CK1A	4G13-3 (1.3)	–	Single	–	–	CARB	F5M41-1 F4A41-1	5M/T 4A/T	– –
		4G13-3 (1.3)	–	Single	–	–	MPI	F5M41-1 F4A41-1	5M/T 4A/T	– –
	CK2A	4G15-5 (1.5)	–	Single	–	–	MPI	F5M41-1 F4A41-1	5M/T 4A/T	– –
		4G15-4 (1.5)	–	Double	–	–	MPI	F5M41-1 F4A41-1	5M/T 4A/T	– –
	CK4A	4G92-3 (1.6)	–	Single	–	–	MPI	F5M41-1 F4A41-1	5M/T 4A/T	– –
4G92-7 (1.6)		–	Double	–	–	MPI	F5M42-1 F4A42-1	5M/T 4A/T	– –	
Space Runner	N11W	4G93-0 (1.8)	–	Single	–	–	MPI	F5M22-1 F4A22-2	5M/T 4A/T	– –
Space Wagon	N31W	4G93-0 (1.8)	–	Single	–	–	CARB	F5M22-1 F4A22-2	5M/T 4A/T	– –

GENERAL EXPORT for 1997

Brand	Vehicle Model	Engine					Fuel System	Transmission		
		Model (lit.)	Silent shaft	Camshaft	Lash adjuster	Turbo charger		Model	Type	4WD
Space Wagon	N33W	4G63-6 (2.0)	x	Single	x	-	MPI	F5M22-1	5M/T	-
								F4A22-2	4A/T	-
Galant	EA1A	4G93-9 (1.8)	-	Single	-	-	CARB	F5M42-1 F4A42-1	5M/T 4A/T	- -
	EA2A	4G63-6 (2.0)	x	Single	x	-	CARB	F5M42-1 F4A42-1	5M/T 4A/T	- -
	EA5A	6A13-4 (2.5)	-	Double	x	-	MPI	F5M42-2 F4A42-2	5M/T 4A/T	- -
Pajero/ Montero	V11V V31V	4G64-6	x	Single	x	-	CARB	V5M21-6	5M/T	x x
	V13V V33V	6G72-1 (3.0)	-	Double	x	-	MPI	V5MT1-6	5M/T	x
	V14V V14C V34V	4D56-2 (2.5)	x	Single	-	-	Diesel S-RGS	V5M21-6	5M/T	x
	V11W V31V	4G64-2	x	Single	x	-	MPI	V5M21-6	5M/T	x
	V31W	4G64-2	x	Single	x	-	MPI	V5M21-6 V4AW2-A	5M/T 4A/T	x x
	V23W	6G72-1 (3.0)	-	Double	x	-	MPI	V5MT1-6 V4AW2-2	5M/T 4A/T	x x
	V24W V44W	4D56-2 (2.5)	x	Single	-	x	Diesel S-RGS	V5MT1-6	5M/T	x
	V43W	6G72-1 (3.0)	-	Double	x	-	MPI	V5MT1-6 V4AW2-7	5M/T 4A/T	x x
	V25W V45W	6G74-1 (3.5)	-	Four	x	-	MPI	V5M31-5 V4AW3-7	5M/T 4A/T	x x
	V36V V36W	4M40 (2.8)	x	Single	-	-	Diesel S-RGS	V5M21-6	5M/T	x

GENERAL EXPORT for 1997

Brand	Vehicle Model	Engine					Fuel System	Transmission			
		Model (lit.)	Silent shaft	Camshaft	Lash adjuster	Turbo charger		Model	Type	4WD	
Pajero/ Montero	V44W	4D56-2 (2.5)	×	Single	–	×	Diesel S-RGS	V5MT1-6 V4AW2-7	5M/T 4A/T	×	×
	V46W	4M40 (2.8)	×	Single	–	×	Diesel S-RGS	V5M31-5 V4AW3-7	5M/T 4A/T	×	×
L200	K02T K12T	4G63-8 (2.0)	–	Single	–	–	CARB	R5M21-1	5M/T	–	–
	K03T K13T	4G54-1 (2.6)	–	Single	–	–	CARB	R5M21-1	5M/T	–	–
	K14T	4G56-2 (2.5)	×	Single	–	–	Diesel S-RGS	R5M21-5	5M/T	–	–
	K15T	4G64-3 (2.4)	×	Single	×	–	MPI	R5M21-9	5M/T	–	–
	K24T K34T	4D56-2 (2.5)	×	Single	–	–	Diesel S-RGS	V5M21-5	5M/T	×	×
	K34T	4D56-2 (2.5)	×	Single	–	×	Diesel S-RGS	V5M21-5	5M/T	×	×
	K32T	4G63-8 (2.0)	–	Single	–	–	CARB	V5M21-1	5M/T	×	×
	K35T	4G64-3 (2.4)	×	Single	×	–	MPI	V5M21-9	5M/T	×	×
	K62T	4G63-6 (2.0)	×	Single	–	–	CARB MPI	R5M21-5	5M/T	–	–
	K64T	4D56-3 (2.5)	×	Single	–	–	Diesel S-RGS	R5M21-5	5M/T	–	–
	K65T	4G64-2 (2.4)	×	Single	–	–	MPI	R5M21-5 R4AW2-6	5M/T 4A/T	–	–
	K72T	4G63-6 (2.0)	×	Single	–	–	CARB MPI	V5M21-5	5M/T	×	×

GENERAL EXPORT for 1997

Brand	Vehicle Model	Engine					Fuel System	Transmission		
		Model (lit.)	Silent shaft	Camshaft	Lash adjuster	Turbo charger		Model	Type	4WD
L200	K74T	4D56-3 (2.5)	×	Single	–	–	Diesel S-RGS	V5M21-5	5M/T	×
	K75T	4G64-2 (2.4)	×	Single	–	–	MPI	V5M21-5	5M/T	×
L300	P06V	4G93-0 (1.8)	–	Single	–	–	CARB	R5M21-2	5M/T	–
	P03V P03W P13W	4G63-B (2.0)	×	Single	×	–	CARB	R5M21-2	5M/T	–
	P13V	4G63-6 (2.0)	×	Single	×	–	MPI	R5M21-2	5M/T	–
		4G63-B (2.0)	×	Single	×	–	CARB	R5M21-2	5M/T	–
	P15V P15W	4D56-2 (2.5)	×	Single	–	–	Diesel S-RGS	R5M21-2	5M/T	–
	P23W	4G63-B (2.0)	×	Single	×	–	CARB	V5M21-2	5M/T	×
	L400	PA3V PB3V	4G63-B (2.0)	–	Single	×	–	CARB	R5M21-7	5M/T
PB4V		4G64-2 (2.4)	×	Single	×	–	MPI	R5M21-7	5M/T	–
PB5V		4D56-2 (2.5)	×	Single	–	×	Diesel S-RGS	R5M31-7	5M/T	–
Space Gear	PA3W	4G63-B (2.0)	×	Single	×	–	CARB	R5M21-7 R4AW2-5	5M/T 4A/T	–
		4G63-6 (2.0)	×	Single	×	–	MPI	R5M21-7	5M/T	–
	PC3W	4G63-B (2.0)	×	Single	×	–	CARB	R5M21-7	5M/T	–
	PA4W	4G64-2 (2.4)	×	Single	×	–	MPI	R5M21-7 R4AW2-5	5M/T 4A/T	–

GENERAL EXPORT for 1997

Brand	Vehicle Model	Engine					Fuel System	Transmission		
		Model (lit.)	Silent shaft	Camshaft	Lash adjuster	Turbo charger		Model	Type	4WD
Space Gear	PA5W	4D56-2 (2.5)	×	Single	–	×	Diesel S-RGS	R5M31-7	5M/T	–
	PD3W	4G63-B (2.0)	×	Single	×	–	MPI	V5M21-7	5M/T	×
	PD4W	4G64-2 (2.4)	×	Single	×	–	MPI	V5M21-7	5M/T	×
	PD5W	4D56-2 (2.5)	×	Single	–	×	Diesel S-RGS	V5M31-7	5M/T	×
SIGMA	F36A	6G72-5 (3.0)	–	Double	×	–	MPI	F5M51-1 F4A51-2	5M/T 4A/T	– –
3000GT	Z16A	6G72-4 (3.0)	–	Four	×	×	MPI	W5MG1-2	6M/T	×
Eclipse	D32A	4G63-7 (2.0)	×	Double	×	–	MPI	F5M31-2	5M/T	–

AUSTRALIA for 1997

Brand	Vehicle Model	Engine					Fuel System	Transmission		
		Model (lit.)	Silent shaft	Camshaft	Lash adjuster	Turbo charger		Model	Type	4WD
Mirage	CJ2A	4G15-3 (1.5)	-	Single	-	-	MPI	F5M41-1 F4A41-1	5M/T 4A/T	- -
	CJ5A	4G93-3 (1.8)	-	Single	-	-	MPI	F5M41-1 F4A41-1	5M/T 4A/T	- -
Lancer Wagon	CB5W	4G93-0 (1.8)	-	Single	-	-	MPI	F5M22-2 F4A22-2	5M/T 4A/T	- -
Lancer	CK2A	4G15-3 (1.5)	-	Single	-	-	MPI	F5M41-1 F4A41-1	5M/T 4A/T	- -
	CK5A	4G93-3 (1.8)	-	Single	-	-	MPI	F5M41-1 F4A41-1	5M/T 4A/T	- -
Space Wagon	N34W	4G64-6 (2.4)	x	Single	x	-	MPI	F5M31-2 F4A23-2	5M/T 4A/T	- -
Pajero/ Montero	V23W V43W	6G72-1 (3.0)	-	Double	x	-	MPI	V5MT1-6 V4AW2-7	5M/T 4A/T	x x
	V36W	4M40 (2.8)	x	Single	-	x	Diesel S-RGS	V5M21-6	5M/T	x
	V46W	4M40 (2.8)	x	Single	-	x	Diesel S-RGS	V5M31-5	5M/T	x
	V45W	6G74-1 (3.5)	-	Four	x	-	MPI	V4AW3-7	4A/T	x
L200	K65T	4G64-2 (2.4)	x	Single	x	-	MPI	R5M21-5 R4AW2-6	5M/T 4A/T	- -
	K67T	4M40 (2.8)	x	Single	-	-	Diesel S-RGS	R5M21-6	5M/T	-
	K76T	6G72-8 (3.0)	-	Double	x	-	MPI	V5MT1-4 V4AW3-6	5M/T 4A/T	x x
	K77T	4M40 (2.8)	x	Single	-	-	Diesel S-RGS	V5M21-6	5M/T	x

AUSTRALIA for 1997

Brand	Vehicle Model	Engine					Fuel System	Transmission		
		Model (lit.)	Silent shaft	Camshaft	Lash adjuster	Turbo charger		Model	Type	4WD
L300	P03V	4G63-9 (2.0)	×	Single	×	–	CARB	R5M21-2 R4AW2-2	5M/T 4A/T	– –
		4G63-A (2.0)	×	Single	×	–	CARB	R5M21-2 R4AW2-8	5M/T 4A/T	– –
	P03W	4G63-9 (2.0)	×	Single	×	–	CARB	R5M21-2 R4AW2-2	5M/T 4A/T	– –
	P05V P15V	4D56-2 (2.5)	×	Single	–	–	Diesel S-RGS	R5M21-2	5M/T	–
	P14V	4G64-2 (2.4)	×	Single	×	–	MPI	R5M21-2 R4AW2-8	5M/T 4A/T	– –
	P24V	4G64-2 (2.4)	×	Single	×	–	MPI	V5M21-2	5M/T	×
L400	PB4V PA4W	4G64-2 (2.4)	×	Single	×	–	MPI	R5M21-7 R4AW2-5	5M/T 4A/T	– –
	PA3W	4G63-A (2.0)	×	Single	×	–	CARB	R5M21-7 R4AW2-5	5M/T 4A/T	– –
	PB6W	6G72-8 (3.0)	–	Double	×	–	MPI	R4AW3-5	4A/T	–
SIGMA	F36A	6G72-5 (3.0)	–	Double	×	–	MPI	F5M51-1 F4A51-2	5M/T 4A/T	– –
3000GT	Z16A	6G72-4 (3.0)	–	Four	×	×	MPI	W5MG1-2	6M/T	×

EUROPE for 1998

Brand	Vehicle Model	Engine					Fuel System	Transmission		
		Model (lit.)	Silent shaft	Camshaft	Lash adjuster	Turbo charger		Model	Type	4WD
Colt	CJ1A	4G13-3 (1.3)	-	Single	-	-	MPI	F5M41-1 F4A41-1	5M/T 4A/T	- -
	CJ4A	4G92-3 (1.6)	-	Single	-	-	MPI	F5M41-1 F4A41-1	5M/T 4A/T	- -
		4G92-8 (1.6)	-	Single	-	-	MPI	F5M41-1	5M/T	-
Lancer	CB4W	4G92-0 (1.6)	-	Single	-	-	MPI	F5M22-2 F4A22-2	5M/T 4A/T	- -
	CD4W	4G92-0 (1.6)	-	Single	-	-	MPI	W5M31-2	5M/T	x
	CK1A	4G13-3 (1.3)	-	Single	-	-	MPI	F5M41-1 F4A41-1	5M/T 4A/T	- -
Carisma	DA1A	4G92-2 (1.6)	-	Single	-	-	MPI	F5MR1(JB3) F4A41-1	5M/T 4A/T	- -
	DA2A	4G93-2 (1.8)	-	Single	-	-	MPI	F5MR1(JB3) F4A42-1	5M/T 4A/T	- -
		4G93-G (1.8)	-	Double	x	-	GDI	F5M42-1 F4A42-1	5M/T 4A/T	-
	DA4A	F8QT (1.8)	-	Single	-	-	Diesel S-QGS	F5MR3 (JC5)	5M/T	-
Space Runner	N11W	4G93-0 (1.8)	-	Single	-	-	MPI	F5M22-1 F4A22-2	5M/T 4A/T	- -
	N18W	4D68-0 (2.0)	x	Single	-	x	Diesel S-RGS	F5M31-1	5M/T	-
	N21W	4G93-0 (1.8)	-	Single	-	-	MPI	W5M31-2	5M/T	x
Space Wagon	N33W	4G63-6 (2.0)	x	Single	x	-	MPI	F5M22-1 F4A22-2	5M/T 4A/T	- -
	N38W	4D68-0 (2.0)	x	Single	-	x	Diesel S-RGS	F5M31-1	5M/T	-
	N43W	4G63-6 (2.0)	x	Single	-	x	MPI	W5M31-2 W4A32-1	5M/T 4A/T	x x

EUROPE for 1998

Brand	Vehicle Model	Engine					Fuel System	Transmission		
		Model (lit.)	Silent shaft	Camshaft	Lash adjuster	Turbo charger		Model	Type	4WD
Galant	EA2A EA2W	4G63-6 (2.0)	×	Single	×	–	MPI	F5M42-2 F4A42-2	5M/T 4A/T	– –
	EA5A EA5W	6A13-4 (2.5)	–	Double	×	–	MPI	F5M42-2 F4A42-2	5M/T 4A/T	– –
	EA6A EA6W	4D68-4 (2.0)	×	Single	–	×	Diesel S-RGS	F5M42-2	5M/T	–
Pajero/ Montero	V23C V23W	6G72-8 (3.0)	–	Double	×	–	MPI	V5MT1-6 V4AW3-B	5M/T 4A/T	×
	V24C V24W V44W	4D56-2 (2.5)	×	Single	–	×	Diesel S-RGS	V5MT1-6	5M/T	×
	V25W V45W	6G74-1 (3.5)	–	Four	×	–	MPI	V5M31-5 V4AW3-B	5M/T 4A/T	×
	V26W	4M40 (2.8)	×	Single	–	×	Diesel S-RGS	V5M31-5	5M/T	×
	V43W	6G72-8 (3.0)	–	Double	×	–	MPI	V5MT1-6 V4AW3-B V4AW3-7	5M/T 4A/T 4A/T	×
	V46W	4M40 (2.8)	×	Single	–	×	Diesel S-RGS	V5M31-5 V4AW3-B	5M/T 4A/T	×
	V46W	4M40 (2.8)	×	Single	–	×	Diesel S-RGS	V5M31-5 V4AW3-B	5M/T 4A/T	×
L200	K62T	4G63-6 (2.0)	×	Single	×	–	MPI	R5M21-5 R4AW2-6	5M/T 4A/T	– –
	K64T	4D56-3 (2.5)	×	Single	–	–	Diesel S-RGS	R5M21-5	5M/T	–
	K74T	4D56-3 (2.5)	×	Single	–	×	Diesel S-RGS	V5MT1-4 V4AW2-6	5M/T 4A/T	×
	K75T	4G64-2 (2.4)	×	Single	×	–	MPI	V5M21-9	5M/T	×

EUROPE for 1998

Brand	Vehicle Model	Engine					Fuel System	Transmission		
		Model (lit.)	Silent shaft	Camshaft	Lash adjuster	Turbo charger		Model	Type	4WD
L300	P03V P13V	4G63-6 (2.0)	×	Single	×	–	MPI	R5M21-2	5M/T	–
	P05V P15V	4D56-2 (2.5)	×	Single	–	×	Diesel S-RGS	R5M21-2	5M/T	–
	P13T	4G63-6 (2.0)	×	Single	×	–	MPI	R5M21-2	5M/T	–
	P15T	4D56-2 (2.5)	×	Single	–	×	Diesel S-RGS	R5M21-2	5M/T	–
	P45V	4D56-2 (2.5)	×	Single	–	×	Diesel S-RGS	V5M21-2	5M/T	×
L400	PA3V PB3V	4G63-6 (2.0)	×	Single	×	–	MPI	R5M21-7	5M/T	–
	PA5V PB5V	4D56-2 (2.5)	×	Single	–	×	Diesel S-RGS	R5M21-7	5M/T	–
	PD4V	4G64-2 (2.4)	×	Single	×	–	MPI	V5M21-7	5M/T	×
	PD5V	4D56-2 (2.5)	×	Single	–	×	Diesel S-RGS	V5M21-7	5M/T	×
Space Gear	PA3W	4G63-6 (2.0)	×	Single	×	–	MPI	R5M21-7 R4AW2-5	5M/T 4A/T	– –
	PA4W	4G64-2 (2.4)	×	Single	×	–	MPI	R5M21-7 R4AW2-5 R4AW2-8	5M/T 4A/T 4A/T	– – –
	PA5W	4D56-2 (2.5)	×	Single	–	×	Diesel S-RGS	R5M31-7	5M/T	–
	PD4W	4G64-2 (2.4)	×	Single	×	–	MPI	V5M21-7	5M/T	×
	PD5W	4D56-2 (2.5)	×	Single	–	×	Diesel S-RGS	V5M31-7	5M/T	×
3000GT	Z16A	6G72-4 (3.0)	–	Four	×	×	MPI	W6MG1-0	6M/T	×
Eclipse	D32T	4G63-7 (2.0)	×	Double	×	–	MPI	F5M31-2	5M/T	–

GENERAL EXPORT for 1998

Brand	Vehicle Model	Engine					Fuel System	Transmission		
		Model (lit.)	Silent shaft	Camshaft	Lash adjuster	Turbo charger		Model	Type	4WD
Colt	CJ1A	4G13-3 (1.3)	–	Single	–	–	CARB	F5M41-1	5M/T	–
		4G13-5 (1.3)	–	Single	–	–	CARB	F5M41-1	5M/T	–
	CJ2A	4G15-5 (1.5)	–	Single	–	–	CARB	F5M41-1 F4M41-1	5M/T 4A/T	– –
			–	Single	–	–	MPI	F5M41-1 F4A41-1	5M/T 4A/T	– –
Lancer	CB1W	4G13-2 (1.3)	–	Single	–	–	CARB	F5M21-1 F3A21-2	5M/T 3A/T	– –
	CB2W	4G15-2 (1.5)	–	Single	–	–	CARB	F5M21-1 F3A21-2	5M/T 3A/T	– –
	CB4W	4G92-0 (1.6)	–	Single	–	–	MPI	F5M22-2 F4A22-2	5M/T 4A/T	– –
	CK1A	4G13-5 (1.3)	–	Single	–	–	CARB	F5M41-1 F4A41-1	5M/T 4A/T	– –
			–	Single	–	–	MPI	F5M41-1 F4A41-1	5M/T 4A/T	– –
	CK2A	4G15-5 (1.5)	–	Single	–	–	CARB	F5M41-1 F4A41-1	5M/T 4A/T	– –
			–	Single	–	–	MPI	F5M41-1 F4A41-1	5M/T 4A/T	– –
	CK4A	4G92-3 (1.6)	–	Single	–	–	MPI	F5M41-1 F4A41-1	5M/T 4A/T	– –
			–	Double	–	–	MPI	F5M42-1 F4A42-1	5M/T 4A/T	– –
	Space Wagon	N31W	4G93-0 (1.8)	–	Single	–	–	CARB	F5M22-1 F4A22-2	5M/T 4A/T
–				Single	–	–	MPI	F5M22-1 F4A22-2	5M/T 4A/T	– –
	N33W	4G63-6 (2.0)	×	Single	–	–	MPI	F5M22-1 F4A22-2	5M/T 4A/T	– –

GENERAL EXPORT for 1998

Brand	Vehicle Model	Engine					Fuel System	Transmission		
		Model (lit.)	Silent shaft	Camshaft	Lash adjuster	Turbo charger		Model	Type	4WD
Galant	EA1A	4G93-9 (1.8)	-	Single	-	-	CARB	F5M42-1 F4A42-1	5M/T 4A/T	- -
		4G63-E (2.0)	x	Single	x	-	CARB	F5M42-1 F4A42-1	5M/T 4A/T	- -
		4G63-6 (2.0)	x	Single	x	-	CARB	F5M42-1 F4A42-1	5M/T 4A/T	- -
	EA4A	6A12-2 (2.0)	-	Double	x	-	MPI	F5M42-2 F4A42-1	5M/T 4A/T	- -
	EA5A	6A13-4 (2.5)	-	Double	x	-	MPI	F5M42-2 F4A42-2	5M/T 4A/T	- -
	EA6A	4D68-2 (2.0)	x	Single	-	x	Diesel S-RGS	F5M42-2	5M/T	-
Pajero/ Montero	V11V V31V	4G64-6 (2.4)	x	Single	x	-	CARB	V5M21-6	5M/T	x
		4G64-2 (2.4)	x	Single	x	-	MPI	V5M21-6	5M/T	x
	V13V V33V V33W	6G72-1 (3.0)	-	Double	x	-	MPI	V5MT1-6	5M/T	x
		4D56-2 (2.5)	x	Single	-	x	Diesel S-RGS	V5MT1-6	5M/T	x
	V14V V14C V34V	4D56-2 (2.5)	x	Single	-	-	Diesel S-RGS	V5M21-6	5M/T	x
	V23W	6G72-8 (3.0)	-	Double	x	x	MPI	V5MT1-6	5M/T	x
		6G72-1 (3.0)	-	Double	x	-	MPI	V5MT1-6 V4AW2-7	5M/T 4A/T	x x
	V25W V45W	6G74-1 (3.5)	-	Four	x	-	MPI	V5M31-5 V4AW3-B	5M/T 4A/T	x x
V26W	4M40 (3.5)	x	Single	-	-	Diesel S-RGS	V5M31-5	5M/T	x	

GENERAL EXPORT for 1998

Brand	Vehicle Model	Engine					Fuel System	Transmission			
		Model (lit.)	Silent shaft	Camshaft	Lash adjuster	Turbo charger		Model	Type	4WD	
Pajero/ Montero	V31W	4G64-2 (2.4)	×	Single	×	–	MPI	V5M21-6 V4AW2-A	5M/T 4A/T	×	×
	V33W	6G72-1 (3.0)	–	Double	×	–	MPI	V5M21-6	5M/T	×	×
	V36V V36W	4M40 (2.8)	×	Single	–	–	Diesel S-RGS	V5M21-6	5M/T	×	×
	V43W	6G72-1 (3.0)	–	Double	×	–	MPI	V5M21-6 V4AW2-7	5M/T 4A/T	×	×
			6G72-8 (3.0)	–	Double	×	–	MPI	V5M21-6 V4AW3-7	5M/T 4A/T	×
	V44W	4D56-2 (2.5)	×	Single	–	×	Diesel S-RGS	V4AW3-7	4A/T	×	×
	V46W	4M40 (2.8)	×	Single	–	×	Diesel S-RGS	V5M31-5 V4AW3-B	5M/T 4A/T	×	×
L300	P03V P03W P13W	4G63-B (2.0)	×	Single	×	–	CARB	R5M21-2	5M/T	–	–
	P03W	4G63-B (2.0)	×	Single	×	–	CARB	R4AW2-8	4A/T	–	–
	P06V P16V	4G92-0 (1.6)	–	Single	–	–	CARB	R5M21-2	5M/T	–	–
	P13V	4G63-6 (2.0)	×	Single	×	–	MPI	R5M21-2	5M/T	–	–
			4G63-B (2.0)	×	Single	×	–	CARB	R5M21-2	5M/T	–
	P15V P15W	4D56-2 (2.5)	×	Single	–	–	Diesel S-RGS	R5M21-2	5M/T	–	–
	P23W	4G63-B (2.0)	×	Single	×	–	CARB	V5M21-2	5M/T	×	×
L400	PB3V	4G63-B (2.0)	–	Single	×	–	CARB	R5M21-7	5M/T	–	–

GENERAL EXPORT for 1998

Brand	Vehicle Model	Engine					Fuel System	Transmission		
		Model (lit.)	Silent shaft	Camshaft	Lash adjuster	Turbo charger		Model	Type	4WD
Space Gear	PA3W	4G63-B (2.0)	x	Single	x	-	CARB	R4AW2-5	4A/T	-
	PA4W	4G64-2 (2.4)	x	Single	x	-	MPI	R5M21-7 R4AW2-5	5M/T 4A/T	- -
	PA5W PC5W	4D56-2 (2.5)	x	Single	-	x	Diesel S-RGS	R5M21-7	5M/T	-
	PC3W	4G63-B (2.0)	x	Single	x	-	CARB	R5M21-7	5M/T	-
	PD3W	4G63-B (2.0)	x	Single	x	-	CARB	V5M21-7	5M/T	x
	PD4W	4G64-2 (2.4)	x	Single	x	-	MPI	V5M21-7	5M/T	x
	PD5W	4D56-2 (2.5)	x	Single	-	x	Diesel S-RGS	V5M21-7	5M/T	x
Sigma	F36A	6G72-5 (3.0)	-	Double	x	-	MPI	F5M51-1 F4A51-2	5M/T 4A/T	- -
3000GT	Z16A	6G72-4 (3.0)	-	Four	x	x	MPI	W5MG1-2	5M/T	x

AUSTRALIA for 1998

Brand	Vehicle Model	Engine					Fuel System	Transmission		
		Model (lit.)	Silent shaft	Camshaft	Lash adjuster	Turbo charger		Model	Type	4WD
Space Wagon	N34W	4G64-2 (2.4)	x	Single	x	-	MPI	F5M31-2	5M/T	-
								F4A23-2	4A/T	-
Pajero/ Montero	V25W	6G74-8 (3.5)	-	Four	x	-	MPI	V5M31-5	5M/T	x
	V45W							V4AW3-B	4A/T	x
	V46W	4M40 (2.8)	x	Single	-	x	Diesel S-RGS	V5M31-5	5M/T	x
L200	K65T	4G64-2 (2.4)	x	Single	x	-	MPI	R5M21-5	5M/T	-
								R4AW2-6	4A/T	-
	K67T	4M40 (2.8)	x	Single	-	-	Diesel S-RGS	R5M21-5	5M/T	-
K76T	6G72-8 (3.0)	-	Double	x	-	MPI	V5MT1-4	5M/T	x	
							V4AW3-6	4A/T	x	
K77T	4M40 (2.8)	x	Single	-	-	Diesel S-RGS	V5M21-9	5M/T	x	
Challenger	K96T	6G72-8 (3.0)	-	Double	x	-	MPI	V5MT1-4	5M/T	x
								V4AW3-6	4A/T	x
L300	P03V	4G63-A (2.0)	x	Single	x	-	CARB	R5M21-2	5M/T	-
								R4AW2-8	4A/T	-
	P03W	4G63-6 (2.0)	x	Single	x	-	MPI	R5M21-2	5M/T	-
								R4AW2-8	4A/T	-
	P05V P15V	4D56-2 (2.5)	x	Single	-	-	Diesel S-RGS	R5M21-2	5M/T	-
P14V	4G64-2 (2.4)	x	Single	x	-	MPI	R5M21-2	5M/T	-	
								R4AW2-8	4A/T	-
P24V	4G64-2 (2.4)	x	Single	x	-	MPI	V5M21-2	5M/T	x	
L400	PA4A PB4V PB4W	4G64-2 (2.4)	x	Single	x	-	MPI	R5M21-7	5M/T	-
								R4AW2-5	4A/T	-
PA3W	4G63-A (2.0)	x	Single	x	-	CARB	R5M21-7	5M/T	-	
								R4AW2-5	4A/T	-

AUSTRALIA for 1998

Brand	Vehicle Model	Engine					Fuel System	Transmission		
		Model (lit.)	Silent shaft	Camshaft	Lash adjuster	Turbo charger		Model	Type	4WD
Sigma	F36A	6G72-5 (3.0)	–	Double	×	–	MPI	F5M51-1	5M/T	–
								F4A51-2	4A/T	–
3000GT	Z16A	6G72-4 (3.0)	–	Four	×	×	MPI	W5MG1-2	5M/T	×

EUROPE for 1999

Brand	Vehicle Model	Engine					Fuel System	Transmission		
		Model (lit.)	Silent shaft	Camshaft	Lash adjuster	Turbo charger		Model	Type	4WD
Space Star	DG1A	4G13-6 (1.3)	-	Single	-	-	MPI	JB3-241	5M/T	-
	DG5A	4F93-G (1.8)	-	Double	x	-	GDI	F5M42-1	5M/T	-
Space Runner	N61W	4G93-G (1.8)	-	Double	x	-	GDI	F5M42-1 F4A42-1	5M/T 4A/T	- -
Space Wagon	N84W	4G64-G (2.4)	-	Double	x	-	GDI	F5M42-2 F4A42-2	5M/T 4A/T	- -
	N94W	4G64-G (2.4)	-	Double	x	-	GDI	F5M42-2 F4A42-2	5M/T 4A/T	- -
Galant	EA2A EA2W	4G63-6 (2.0)	x	Single	x	-	MPI	F5M42-2 F4A42-2	5M/T 4A/T	- -
	EA3A EA3W	4A64-4 (2.4)	x	Double	x	-	GDI	F5M42-2 F4A42-2	5M/T 4A/T	- -
	EA5A EA5W	6A13-4 (2.5)	-	Double	x	-	MPI	F5M42-2 F4A42-2	5M/T 4A/T	- -
	EA6A EA6W	4D68-4 (2.0)	x	Single	-	x	Diesel S-RGS	F5M42-2	5M/T	-
Pajero/ Montero	V23C V23W	6G72-8 (3.0)	-	Double	x	-	MPI	V5MT1-6 V4AW3-B	5M/T 4A/T	x x
	V24C V24W V44W	4D56-4 (2.5)	x	Single	-	x	Diesel S-RGS	V5MT1-6	5M/T	x
	V25W V45W	6G74-8 (3.5)	-	Four	x	-	MPI	V5M31-5 V4AW3-B	5M/T 4A/T	x x
	V26W	4M40 (2.8)	x	Single	-	x	Diesel S-RGS	V5M31-5	5M/T	x
	V43W	6G72-8 (3.0)	-	Double	x	-	MPI	V5MT1-6 V4AW3-B V4AW3-7	5M/T 4A/T 4A/T	x x x
	V46W	4M40 (2.8)	x	Single	-	x	Diesel S-RGS	V5M31-5 V4AW3-B	5M/T 4A/T	x x

EUROPE for 1999

Brand	Vehicle Model	Engine					Fuel System	Transmission		
		Model (lit.)	Silent shaft	Camshaft	Lash adjuster	Turbo charger		Model	Type	4WD
L200	K62T	4G63-6 (2.0)	×	Single	×	–	MPI	R5M21-5	5M/T	–
								R4AW2-6	4A/T	–
	K64T	4D56-4 (2.5)	×	Single	–	–	Diesel S-RGS	R5M21-5	5M/T	–
								V5MT1-4	5M/T	×
K74T	4D56-4 (2.5)	×	Single	–	×	Diesel S-RGS	V4AW2-6	4A/T	×	
							V5M21-9	5M/T	×	
K75T	4G64-2 (2.4)	×	Single	×	–	MPI	V5M21-9	5M/T	×	
Pajero Sport	K94W	4D56-4 (2.4)	×	Single	–	×	Diesel S-RGS	V5MT1-4	5M/T	×
K96W	6G72-8 (3.0)	×	Four	×	–	MPI	V5MT1-4	5M/T	×	
							V5MT1-6	5M/T	×	
Pajero Pinin	H76W	4G93-H (1.8)	×	Double	×	–	GDI	V5M21-A	5M/T	×
								V4AW4-D	4A/T	×
L300	P03V P13V	4G63-6 (2.0)	×	Single	×	–	MPI	R5M21-2	5M/T	–
	P05V P15V	4D56-4 (2.5)	×	Single	–	×	Diesel S-RGS	R5M21-2	5M/T	–
	P13T	4G63-6 (2.0)	×	Single	×	–	MPI	R5M21-8	5M/T	–
P15T	4D56-4 (2.5)	×	Single	–	×	Diesel S-RGS	R5M21-8	5M/T	–	
P45V	4D56-4 (2.5)	×	Single	–	×	Diesel S-RGS	V5M21-2	5M/T	×	
L400	PA3V PB3V	4G63-6 (2.0)	×	Single	×	–	MPI	R5M21-7	5M/T	–
	PA5V PB5V	4D56-4 (2.5)	×	Single	–	×	Diesel S-RGS	R5M21-7	5M/T	–
PD4V	4G64-2 (2.4)	×	Single	×	–	MPI	V5M21-7	5M/T	×	
PD5V	4D56-2 (2.5)	×	Single	–	×	Diesel S-RGS	V5M21-7	5M/T	×	

EUROPE for 1999

Brand	Vehicle Model	Engine					Fuel System	Transmission		
		Model (lit.)	Silent shaft	Camshaft	Lash adjuster	Turbo charger		Model	Type	4WD
Space Gear	PA3W	4G63-6 (2.0)	×	Single	×	–	MPI	R5M21-7 R4AW2-5	5M/T 4A/T	– –
	PA4W	4G64-2 (2.4)	×	Single	×	–	MPI	R5M21-7 R4AW2-5 R4AW2-8	5M/T 4A/T 4A/T	– – –
	PA5W	4D56-4 (2.5)	×	Single	–	×	Diesel S-RGS	R5M31-7	5M/T	–
	PD4W	4G64-2 (2.4)	×	Single	×	–	MPI	V5M21-7	5M/T	×
	PD5W	4D56-4 (2.5)	×	Single	–	×	Diesel S-RGS	V5M31-7	5M/T	×
3000GT	Z16A	6G72-4 (3.0)	–	Four	×	×	MPI	W6MG1-0	6M/T	×
Eclipse	D32A	4G63-7 (2.0)	×	Double	×	–	MPI	F5M31-2	5M/T	×

GENERAL EXPORT for 1999

Brand	Vehicle Model	Engine					Fuel System	Transmission		
		Model (lit.)	Silent shaft	Camshaft	Lash adjuster	Turbo charger		Model	Type	4WD
Colt	CJ1A	4G13-5 (1.3)	-	Single	-	-	CARB	F5M41-1	5M/T	-
	CJ2A	4G15-5 (1.5)	-	Single	-	-	CARB	F5M41-1 F4A41-1	5M/T 4A/T	-
	CJ4A	4G92-3 (1.6)	-	Single	-	-	MPI	F5M41-1 F4A41-1	5M/T 4A/T	-
Lancer	CB1W	4G13-2 (1.3)	-	Single	-	-	CARB	F5M21-1 F3A21-2	5M/T 3A/T	-
	CB2W	4G15-2 (1.5)	-	Single	-	-	CARB	F5M21-1 F3A21-2	5M/T 3A/T	-
	CK1A	4G13-5 (1.3)	-	Single	-	-	CARB	F5M41-1 F4A41-1	5M/T 4A/T	-
	CK2A	4G15-5 (1.5)	-	Single	-	-	CARB	F5M41-1 F4A41-1	5M/T 4A/T	-
	CK4A	4G92-3 (1.6)	-	Single	-	-	MPI	F5M41-1 F4A41-1	5M/T 4A/T	-
Space Wagon	N84W	4G64-2 (2.4)	x	Double	x	-	GDI	F5M42-2 F4A42-2	5M/T 4A/T	-
Galant	EA1A	4G93-9 (1.8)	-	Single	-	-	CARB	F5M42-1 F4A42-1	5M/T 4A/T	-
	EA2A	4G63-E (2.0)	x	Single	x	-	MPI	F5M42-1 F4A42-1	5M/T 4A/T	-
	EA5A	6A13-4 (2.5)	-	Double	x	-	MPI	F5M42-2 F4A42-2	5M/T 4A/T	-
	EA6A	4D68-2 (2.0)	x	Single	-	x	Diesel S-RGS	F5M42-2	5M/T	-
Pajero/ Montero	V11V V31V	4G64-6 (2.4)	x	Single	-	-	CARB	V5M21-6	5M/T	x
	V11W V31V	4G64-2 (2.4)	x	Single	-	-	MPI	V5M21-6	5M/T	x
	V13V V33V	6G72-1 (3.0)	-	Double	x	-	MPI	V5MT1-6	5M/T	x

GENERAL EXPORT for 1999

Brand	Vehicle Model	Engine					Fuel System	Transmission		
		Model (lit.)	Silent shaft	Camshaft	Lash adjuster	Turbo charger		Model	Type	4WD
Pajero/ Montero	V14C V24W	4D56-4 (2.5)	×	Single	–	×	Diesel S-RGS	V5MT1-6	5M/T	×
	V14V V34W	4D56-4 (2.5)	×	Single	–	–	Diesel S-RGS	V5M21-6	5M/T	×
	V23W	6G72-8 (3.0)	–	Double	×	–	MPI	V5MT1-6	5M/T	×
		6G72-1 (3.0)	–	Double	×	–	MPI	V5MT1-6 V4AW2-7	5M/T 4A/T	×
	V25W V45W	6G74-1 (3.5)	–	Four	×	–	MPI	V5M31-5 V4AW3-B	5M/T 4A/T	×
	V31W	4G64-2 (2.4)	×	Single	–	–	MPI	V5M21-6 V4AW2-A	5M/T 4A/T	×
	V36V V36W	4M40 (2.8)	×	Single	–	–	Diesel S-RGS	V5M21-6	5M/T	×
	V43W	6G72-1 (3.0)	–	Double	–	×	MPI	V5M21-6 V4AW2-7	5M/T 4A/T	×
		6G72-8 (3.0)	–	Double	×	–	MPI	V5M21-6 V4AW3-7	5M/T 4A/T	×
	V44W	4D56-4 (2.5)	×	Single	×	–	Diesel S-RGS	V4AW3-7	4A/T	×
V46W	4M40 (2.8)	×	Single	–	×	Diesel S-RGS	V5M31-5 V4AW3-B	5M/T 4A/T	×	
L200	K62T	4G63-6 (2.0)	×	Single	×	–	MPI	R5M21-5	5M/T	–
		4G63-B (2.0)	×	Single	×	–	MPI	R5M21-5	5M/T	–
	K64T	4D56-4 (2.5)	×	Single	–	×	Diesel S-RGS	R5M21-5	5M/T	–
	K65T	4G64-2 (2.4)	×	Single	×	–	MPI	R5M21-5	5M/T	–

GENERAL EXPORT for 1999

Brand	Vehicle Model	Engine					Fuel System	Transmission		
		Model (lit.)	Silent shaft	Camshaft	Lash adjuster	Turbo charger		Model	Type	4WD
L200	K72T	4G63-6 (2.0)	×	Single	×	–	CARB	V5M21-9	5M/T	×
		4G63-B (2.0)	×	Single	×	–	CARB	V5M21-9	5M/T	×
		4G64-2 (2.4)	×	Single	×	–	MPI	V5M21-9	5M/T	×
	K74T	4D56-4 (2.5)	×	Single	–	×	Diesel S-RGS	V5M21-9 V5MT1-4	5M/T 5M/T	×
			×	Single	–	×	Diesel S-RGS	V5MT1-4	5M/T	×
Pajero io	H65W	4G18-6 (1.6)	–	Single	×	–	MPI	V5M21-A V4AW4-D	5M/T 4A/T	×
	H76W	4G93-D (1.8)	–	Double	×	–	GDI	V5M21-A V4AW4-D	5M/T 4A/T	×
L300	P03V P03W P13W	4G63-B (2.0)	×	Single	×	–	CARB	R5M21-2	5M/T	–
			×	Single	×	–	CARB	R4AW2-8	4A/T	–
	P06V P16V	4G92-0 (1.6)	–	Single	–	–	CARB	R5M21-2	5M/T	–
			×	Single	×	–	MPI	R5M21-2	5M/T	–
	P13V	4G63-B (2.0)	×	Single	×	–	CARB	R5M21-2	5M/T	–
			×	Single	×	–	CARB	R5M21-2	5M/T	–
	P15V P15W	4D56-4 (2.5)	×	Single	–	–	Diesel S-RGS	R5M21-2	5M/T	–
×			Single	×	–	CARB	V5M21-2	5M/T	×	
L400	PB3V	4G63-B (2.0)	–	Single	×	–	CARB	R5M21-7	5M/T	–

GENERAL EXPORT for 1999

Brand	Vehicle Model	Engine					Fuel System	Transmission		
		Model (lit.)	Silent shaft	Camshaft	Lash adjuster	Turbo charger		Model	Type	4WD
Space Gear	PA3W	4G63-B (2.0)	×	Single	×	–	CARB	R4AW2-5	4A/T	–
	PA4W	4G64-2 (2.4)	×	Single	×	–	MPI	R5M21-7 R4AW2-5	5M/T 4A/T	– –
	PA5W PC5W	4D56-4 (2.5)	×	Single	–	×	Diesel S-RGS	R5M21-7	5M/T	–
	PC3W	4G63-B (2.0)	×	Single	×	–	CARB	R5M21-7	5M/T	–
	PD3W	4G63-B (2.0)	×	Single	×	–	CARB	V5M21-7	5M/T	×
	PD4W	4G64-2 (2.4)	×	Single	×	–	MPI	V5M21-7	5M/T	×
	PD5W	4D56-4 (2.5)	×	Single	–	×	Diesel S-RGS	V5M21-7	5M/T	×
Sigma	F36A	6G72-5 (3.0)	–	Double	×	–	MPI	F4A51-2	4A/T	–
3000GT	Z16A	6G72-4 (3.0)	–	Four	×	×	MPI	W5MG1-2	5M/T	×

AUSTRALIA for 1999

Brand	Vehicle Model	Engine					Fuel System	Transmission		
		Model (lit.)	Silent shaft	Camshaft	Lash adjuster	Turbo charger		Model	Type	4WD
Colt	CJ2A	4G15-3 (1.5)	-	Single	x	-	MPI	F5M41-1 F4A41-1	5M/T 4A/T	- -
	CJ5A	4G93-3 (1.8)	-	Single	x	-	MPI	F5M41-1 F4A41-1	5M/T 4A/T	- -
Lancer	CB5W	4G93-0 (1.8)	-	Single	x	-	MPI	F5M22-2 F4A22-2	5M/T 4A/T	- -
	CK2A	4G15-3 (1.5)	-	Single	x	-	MPI	F5M41-1 F4A41-1	5M/T 4A/T	- -
	CK5A	4G93-3 (1.8)	-	Single	x	-	MPI	F5M41-1 F4A41-1	5M/T 4A/T	- -
Space Wagon	N84W	4G64-2 (2.4)	x	Single	x	-	MPI	F5M42-2 F4A42-2	5M/T 4A/T	- -
Pajero/ Montero	V25W V45W	6G74-8 (3.5)	-	Four	x	-	MPI	V5M31-5 V4AW3-B	5M/T 4A/T	x x
	V46W	4M40 (2.8)	x	Single	-	x	Diesel S-RGS	V5M31-5	5M/T	x
Pajero io	H65W	4G18-6 (1.8)	-	Single	x	-	MPI	V5M21-A	5M/T	x
	H76W	4G93-D (1.8)	-	Single	x	-	MPI	V5M21-A V4AW4-D	5M/T 4A/T	x x
L200	K65T	4G64-2 (2.4)	x	Single	x	-	MPI	R5M21-5 R4AW2-6	5M/T 4A/T	- -
	K67T	4M40 (2.8)	x	Single	-	-	Diesel S-RGS	R5M21-5	5M/T	-
	K76T	6G72-8 (3.0)	-	Double	x	-	MPI	V5MT1-4 V4AW3-6	5M/T 4A/T	x x
	K77T	4M40 (2.8)	x	Single	-	-	Diesel S-RGS	V5M21-9	5M/T	x
Challenger K96W		6G72-8 (3.0)	-	Double	x	-	MPI	V5MT1-4 V4AW3-6	5M/T 4A/T	x x

AUSTRALIA for 1999

Brand	Vehicle Model	Engine					Fuel System	Transmission		
		Model (lit.)	Silent shaft	Camshaft	Lash adjuster	Turbo charger		Model	Type	4WD
L300	P03V	4G63-A (2.0)	×	Single	×	–	CARB	R5M21-2 R4AW2-8	5M/T 4A/T	– –
	P03W	4G63-6 (2.0)	×	Single	×	–	MPI	R5M21-2 R4AW2-8	5M/T 4A/T	– –
	P05V P15V P25V	4D56-4 (2.5)	×	Single	–	–	Diesel S-RGS	R5M21-2	5M/T	–
	P15V	4G56-2 (2.5)	×	Single	–	–	Diesel S-RGS	R5M21-2	5M/T	–
	P14V P04W	4G64-2 (2.4)	×	Single	×	–	MPI	R5M21-2 R4AW2-8	5M/T 4A/T	– –
	P04V P24V P14W	4G64-2 (2.4)	×	Single	×	–	MPI	V5M21-2	5M/T	×
L400	PA3V	4G63-6 (2.0)	×	Single	×	–	MPI	R5M21-7 R4AW2-5	5M/T 4A/T	– –
	PD4A PB4W	4G64-2 (2.4)	×	Single	×	–	MPI	R5M21-7	5M/T	–
	PA4W PB4V	4G64-2 (2.4)	×	Single	×	–	MPI	R5M21-7 R4AW2-5	5M/T 4A/T	– –
	PA3W	4G63-6 (2.0)	×	Single	×	–	MPI	R5M21-7 R4AW2-5	5M/T 4A/T	– –
Sigma	F36A	6G72-5 (3.0)	–	Double	×	–	MPI	F5M51-1 F4A51-2	5M/T 4A/T	– –
	F38A	6G74-5 (3.5)	–	Double	×	–	MPI	F5M51-1 F4A51-2	5M/T 4A/T	– –
Magna	F36W	6G72-5 (3.0)	–	Double	×	–	MPI	F5M51-1 F4A51-2	5M/T 4A/T	– –
	F38W	6G74-5 (3.5)	–	Double	×	–	MPI	F5M51-1 F4A51-2	5M/T 4A/T	– –
3000GT	Z16A	6G72-4 (3.0)	–	Four	×	×	MPI	W5MG1-2	5M/T	×

EUROPE for 2000

Brand	Vehicle Model	Engine					Fuel System	Transmission		
		Model (lit.)	Silent shaft	Camshaft	Lash adjuster	Turbo charger		Model	Type	4WD
Lancer Station Wagon	CB4W	4G92-0 (1.6)	-	Single	-	-	MPI	F5M22-2 F4A22-2	5M/T 4A/T	- -
	CD4W	4G92-0 (1.6)	-	Single	-	-	MPI	W5M31-2	5M/T	×
Colt	CJ1A CK1A	4G13-3 (1.3)	-	Single	-	-	MPI	F5M41-1 F4A41-1	5M/T 4A/T	- -
	CJ4A	4G92-3 (1.6)	-	Single	-	-	MPI	F5M41-1 F4A41-1	5M/T 4A/T	- -
Carisma	DA1A	4G92-2 (1.6)	-	Single	-	-	MPI	JB3-242 F4A41-1	5M/T 4A/T	- -
	DA2A	4G93-G (1.8)	-	Double	×	-	GDI	F5M42-1 F4A42-1	5M/T 4A/T	- -
	DA4A	F8QT-1 (1.9)	-	Single	-	×	Diesel S-RGS	JC5-225	5M/T	-
Space Runner	N63W	4G63-6 (2.0)	×	Single	-	-	MPI	F5M42-2 R5M21-8 F4A42-1	5M/T 5M/T 4A/T	- - -
	N64W	4G64-4 (2.4)	×	Double	×	-	GDI	F5M42-2 F4A42-2	5M/T 4A/T	- -
Space Wagon	N84W	4G64-4 (2.4)	×	Double	×	-	GDI	F5M42-2 F4A42-2	5M/T 4A/T	- -
	N94W	4G64-4 (2.4)	×	Double	×	-	GDI	W5M42-1	5M/T	×
Pajero	V23C V23W	6G72-8 (3.0)	-	Double	×	-	MPI	V5MT1-6 V4AW3-B	5M/T 4A/T	×
	V24C V24W V44W	4D56-4 (2.5)	×	Single	-	×	Diesel S-RGS	V5MT1-6	5M/T	×
	V25W V45W	6G74-8 (3.5)	-	Double	×	-	MPI	V5M31-5 V4AW3-B	5M/T 4A/T	×
	V26W	4M40 (2.8)	×	Single	-	×	Diesel S-RGS	V5M31-5	5M/T	×

EUROPE for 2000

Brand	Vehicle Model	Engine					Fuel System	Transmission			
		Model (lit.)	Silent shaft	Camshaft	Lash adjuster	Turbo charger		Model	Type	4WD	
Pajero	V43W	6G72-1 (3.0)	–	Double	×	–	MPI	V5MT1-6 V4AW2-7	5M/T 4A/T	×	×
		6G72-8 (3.0)	–	Double	×	–	MPI	V5MT1-6 V4AW3-7	5M/T 4A/T	×	×
	V46W	4M40 (2.8)	×	Single	–	×	Diesel S-RGS	V5M31-5 V4AW3-B	5M/T 4A/T	×	×
L200	K62T	4G63-6 (2.0)	×	Single	×	–	MPI	R5M21-5 R4AW2-6	5M/T 4A/T	–	–
	K64T	4D56-4 (2.5)	×	Single	–	–	Diesel S-RGS	R5M21-5	5M/T	–	–
	K74T	4D56-4 (2.5)	×	Single	–	×	Diesel S-RGS	V5MT1-4 V4AW2-6	5M/T 4A/T	×	×
	K75T	4G64-2 (2.4)	×	Single	×	–	MPI	V5M21-9	5M/T	×	×
Pajero Sport	K94W	4D56-4 (2.4)	×	Single	–	×	Diesel S-RGS	V5MT1-B	5M/T	×	×
	K96W	6G72-8 (3.0)	–	Double	×	–	MPI	V5MT1-B V4A51-5	5M/T 4A/T	×	×
L300	P03V P13V	4G63-6 (2.0)	×	Single	×	–	MPI	R5M21-2	5M/T	–	–
	P05V P15V	4D56-4 (2.5)	×	Single	–	–	Diesel S-RGS	R5M21-2	5M/T	–	–
	P13T	4G63-6 (2.0)	×	Single	×	–	MPI	R5M21-8	5M/T	–	–
	P15T	4D56-4 (2.5)	×	Single	–	×	Diesel S-RGS	R5M21-8	5M/T	–	–
	P45V	4D56-4 (2.5)	×	Single	–	×	Diesel S-RGS	V5M21-2	5M/T	×	×
L400	PA3V PB3V	4G63-6 (2.0)	×	Single	×	–	MPI	R5M21-7	5M/T	–	–
	PA5V PB5V	4D56-4 (2.5)	×	Single	–	×	Diesel S-RGS	R5M21-7	5M/T	–	–

EUROPE for 2000

Brand	Vehicle Model	Engine					Fuel System	Transmission		
		Model (lit.)	Silent shaft	Camshaft	Lash adjuster	Turbo charger		Model	Type	4WD
L400	PD4V	4G64-2 (2.4)	×	Single	×	–	MPI	V5M21-7	5M/T	×
	PD5V	4D56-4 (2.5)	×	Single	–	×	Diesel S-RGS	V5M21-7	5M/T	×
Space Gear	PA3W	4G63-6 (2.0)	×	Single	×	–	MPI	R5M21-7	5M/T	–
	PA4W	4G64-2 (2.4)	×	Single	×	–	MPI	R5M21-7 R4AW2-5	5M/T 4A/T	– –
	PA5W	4D56-4 (2.5)	×	Single	–	×	Diesel S-RGS	R5M31-7	5M/T	–
	PD4W	4G64-2 (2.4)	×	Single	×	–	MPI	V5M21-7	5M/T	×
	PD5W	4D56-4 (2.5)	×	Single	–	×	Diesel S-RGS	V5M31-7	5M/T	×
3000GT	Z16A	6G72-4 (3.0)	–	Four	×	×	MPI	W6MG1-0	6M/T	×

GENERAL EXPORT for 2000

Brand	Vehicle Model	Engine					Fuel System	Transmission		
		Model (lit.)	Silent shaft	Camshaft	Lash adjuster	Turbo charger		Model	Type	4WD
Colt	CJ1A	4G13-5 (1.3)	–	Single	–	–	CARB	F5M41-1 F4A41-1	5M/T 4A/T	– –
		4G15-5 (1.5)	–	Single	–	–	CARB	F5M41-1 F4A41-1	5M/T 4A/T	– –
	CJ4A	4G13-5 (1.3)	–	Single	–	–	CARB	F5M41-1 F4A41-1	5M/T 4A/T	– –
		4G92-3 (1.6)	–	Single	–	–	MPI	F5M41-1 F4A41-1	5M/T 4A/T	– –
		4G92-3 (1.6)	–	Single	–	–	MPI	F4A41-1	4A/T	–
Lancer Station Wagon	CB1W	4G13-2 (1.3)	–	Single	–	–	CARB	F5M21-1 F3A21-2	5M/T 3A/T	– –
		4G15-2 (1.5)	–	Single	–	–	CARB	F5M21-1 F3A21-2	5M/T 3A/T	– –
	CB4W	4G92-0 (1.6)	–	Single	–	–	MPI	F5M22-2 F4A22-2	5M/T 4A/T	– –
Lancer	CK1A	4G13-5 (1.3)	–	Single	–	–	CARB	F5M41-1 F4A41-1	5M/T 4A/T	– –
		4G13-3 (1.3)	–	Single	–	–	MPI	F5M41-1 F4A41-1	5M/T 4A/T	– –
	CK2A	4G15-5 (1.5)	–	Single	–	–	CARB	F5M41-1 F4A41-1	5M/T 4A/T	– –
		4G15-4 (1.5)	–	Double	×	–	MPI	F5M41-1 F4A41-1	5M/T 4A/T	– –
	CK4A	4G92-3 (1.6)	–	Single	–	–	MPI	F5M41-1 F4A41-1	5M/T 4A/T	– –
		4G92-7 (1.6)	–	Double	–	–	MPI	F5M42-1 F4A42-1	5M/T 4A/T	– –
Mirage Dingo	CQ2A	4G15-8 (1.5)	–	Double	×	–	GDI	F4A41-1	4A/T	–

GENERAL EXPORT for 2000

Brand	Vehicle Model	Engine					Fuel System	Transmission		
		Model (lit.)	Silent shaft	Camshaft	Lash adjuster	Turbo charger		Model	Type	4WD
Space Wagon	N84W	4G64-2 (2.4)	×	Single	×	–	MPI	F5M42-2 F4A42-2	5M/T 4A/T	– –
		4G64-4 (2.4)	×	Double	×	–	GDI	F4A42-2	4A/T	–
Galant	EA1A	4G93-9 (1.8)	–	Single	–	–	CARB	F5M42-1 F4A42-1	5M/T 4A/T	– –
	EA2A	4G63-E (2.0)	×	Single	×	–	CARB	F5M42-1 F4A42-1	5M/T 4A/T	– –
		4G63-6 (2.0)	×	Single	×	–	MPI	F5M42-1 F4A42-1	5M/T 4A/T	– –
	EA5A	6A13-4 (2.5)	–	Double	×	–	MPI	F5M42-2 F4A42-2	5M/T 4A/T	– –
Pajero	V11V V31V	4G64-6 (2.4)	×	Single	–	–	CARB	V5M21-6	5M/T	×
	V11W V31V	4G64-2 (2.4)	×	Single	–	–	MPI	V5M21-6	5M/T	×
	V13V V33V V33W	6G72-1 (3.0)	–	Double	×	–	MPI	V5MT1-6	5M/T	×
								V4AW2-7	4A/T	×
	V14V V34V	4D56-4 (2.5)	×	Single	–	–	Diesel S-RGS	V5M21-6	5M/T	×
	V23W	6G72-8 (3.0)	–	Double	×	–	MPI	V5MT1-6	5M/T	×
		6G72-1 (3.0)	–	Double	×	–	MPI	V5MT1-6 V4AW2-7	5M/T 4A/T	×
	V24W	4D56-4 (2.5)	×	Single	–	×	Diesel S-RGS	V5MT1-6	5M/T	×
V25W V45W	6G74-1 (3.5)	–	Four	×	–	MPI	V5M31-5 V4AW3-B	5M/T 4A/T	×	
		6G74-8 (3.5)	–	Double	×	–	MPI	V5M31-5 V4AW2-7	5M/T 4A/T	×

GENERAL EXPORT for 2000

Brand	Vehicle Model	Engine					Fuel System	Transmission		
		Model (lit.)	Silent shaft	Camshaft	Lash adjuster	Turbo charger		Model	Type	4WD
Pajero	V26W	4M40 (2.8)	×	Single	–	×	Diesel S-RGS	V5M31-5	5M/T	×
	V31W	4G64-2 (2.4)	×	Single	–	–	MPI	V5M21-6 V4AW2-A	5M/T 4A/T	×
	V36V V36W	4M40 (2.8)	×	Single	–	–	Diesel S-RGS	V5M21-6	5M/T	×
	V43W	6G72-1 (3.0)	–	Double	×	–	MPI	V5MT1-6 V4AW2-7	5M/T 4A/T	×
			–	Double	×	–	MPI	V5MT1-6 V4AW3-7 V4AW3-B	5M/T 4A/T 4A/T	×
			–	Double	×	–	MPI	V5MT1-6 V4AW3-7 V4AW3-B	5M/T 4A/T 4A/T	×
	V44W	4D56-4 (2.5)	×	Single	–	×	Diesel S-RGS	V5MT1-6 V4AW2-7	5M/T 4A/T	×
V46W	4M40 (2.8)	×	Single	–	×	Diesel S-RGS	V5M31-5 V4AW3-B	5M/T 4A/T	×	
L200	K62T	4G63-6 (2.0)	×	Single	×	–	MPI	R5M21-5	5M/T	–
		4G63-6 (2.0)	–	Single	×	–	CARB	R5M21-5	5M/T	–
		4G63-B (2.0)	–	Single	×	–	CARB	R5M21-5	5M/T	–
	K64T	4D56-3 (2.5)	×	Single	–	–	Diesel S-RGS	R5M21-5	5M/T	–
		4D56-4 (2.5)	×	Single	–	–	Diesel S-RGS	R5M21-5	5M/T	–
	K65T	4G64-2 (2.4)	×	Single	×	–	MPI	R5M21-5	5M/T	–
	K67T	4M40 (2.8)	×	Single	–	–	Diesel S-RGS	R5M21-5 R4AW2-6	5M/T 4A/T	–

GENERAL EXPORT for 2000

Brand	Vehicle Model	Engine					Fuel System	Transmission		
		Model (lit.)	Silent shaft	Camshaft	Lash adjuster	Turbo charger		Model	Type	4WD
L200	K72T	4G63-6 (2.0)	–	Single	×	–	CARB	V5M21-9	5M/T	×
		4G63-B (2.0)	–	Single	×	–	CARB	V5M21-9	5M/T	×
	K74T	4D56-3 (2.5)	×	Single	–	×	Diesel S-RGS	V5MT1-4	5M/T	×
		4D56-3 (2.5)	×	Single	–	–	Diesel S-RGS	V5M21-9	5M/T	×
		4D56-4 (2.5)	×	Single	–	–	Diesel S-RGS	V5M21-9	5M/T	×
		4D56-4 (2.5)	×	Single	–	×	Diesel S-RGS	V5MT1-4	5M/T	×
	K75T	4G64-2 (2.4)	×	Single	×	–	MPI	V5M21-9	5M/T	×
	Challenger	K86W	6G72-8 (3.0)	–	Double	×	–	MPI	R5M31-B R4A51-5	5M/T 4A/T
K96W		6G72-8 (3.0)	–	Double	×	–	MPI	V5MT1-B V4A51-5	5M/T 4A/T	×
K97W		4M40 (2.8)	×	Single	–	×	Diesel S-RGS	V5M31-B V4A51-5	5M/T 4A/T	×
L300	P03V P13V	4G63-B (2.0)	–	Single	×	–	CARB	R5M21-2	5M/T	–
	P03W	4G63-B (2.0)	–	Single	×	–	CARB	R5M21-2 R4AW2-8	5M/T 4A/T	– –
	P06V P16V	4G92-0 (1.6)	–	Single	–	–	CARB	R5M21-2	5M/T	–
	P13W	4G63-6 (2.0)	×	Single	×	–	MPI	R5M21-2	5M/T	–
		4G63-B (2.0)	–	Single	×	–	CARB	R5M21-2	5M/T	–
	P15V P15W	4D56-2 (2.5)	×	Single	–	–	Diesel S-RGS	R5M21-2	5M/T	–

GENERAL EXPORT for 2000

Brand	Vehicle Model	Engine					Fuel System	Transmission		
		Model (lit.)	Silent shaft	Camshaft	Lash adjuster	Turbo charger		Model	Type	4WD
L300	P15V	4D56-4 (2.5)	×	Single	–	–	Diesel S-RGS	R5M21-2	5M/T	–
	P23W	4G63-B (2.0)	–	Single	×	–	CARB	V5M21-2	5M/T	×
L400	PB3V	4G63-B (2.0)	–	Single	×	–	CARB	R5M21-7	5M/T	–
	PB5V	4D56-4 (2.5)	×	Single	–	×	Diesel S-RGS	R5M21-7	5M/T	–
Space Gear	PA3W	4G63-B (2.0)	–	Single	×	–	CARB	R4AW2-5	4A/T	–
	PA4W	4G64-2 (2.4)	×	Single	×	–	MPI	R4AW2-5	4A/T	–
	PA5W PC5W	4D56-4 (2.5)	×	Single	–	×	Diesel S-RGS	R5M21-7	5M/T	–
	PC3W	4G63-B (2.0)	–	Single	×	–	CARB	R5M21-7	5M/T	–
	PD3W	4G63-B (2.0)	–	Single	×	–	CARB	V5M21-7	5M/T	×
	PD4W	4G64-2 (2.4)	×	Single	×	–	MPI	V5M21-7	5M/T	×
	PD5W	4D56-4 (2.5)	×	Single	–	×	Diesel S-RGS	V5M21-7	5M/T	×
Sigma	F36A	6G72-5 (3.0)	–	Double	×	–	MPI	F4A51-2	4A/T	–
3000GT	Z16A	6G72-4 (3.0)	–	Four	×	×	MPI	W5MG1-2	5M/T	×

AUSTRALIA for 2000

Brand	Vehicle Model	Engine					Fuel System	Transmission		
		Model (lit.)	Silent shaft	Camshaft	Lash adjuster	Turbo charger		Model	Type	4WD
Colt	CJ2A	4G15-3 (1.5)	-	Single	-	-	MPI	F5M41-1 F4A41-1	5M/T 4A/T	- -
	CJ5A	4G93-3 (1.8)	-	Single	-	-	MPI	F5M42-1 F4A42-1	5M/T 4A/T	- -
Lancer Station Wagon	CB5W	4G93-0 (1.8)	-	Single	-	-	MPI	F5M22-2 F4A22-2	5M/T 4A/T	- -
Lancer	CK2A	4G15-3 (1.5)	-	Single	-	-	MPI	F5M42-1 F4A42-1	5M/T 4A/T	- -
	CK5A	4G93-3 (1.8)	-	Single	-	-	MPI	F5M41-1 F4A41-1	5M/T 4A/T	- -
Space Wagon	N84W	4G64-2 (2.4)	x	Single	x	-	MPI	F5M42-2 F4A42-2	5M/T 4A/T	- -
Pajero	V45W	6G74-8 (3.5)	-	Double	x	-	MPI	V5M31-5 V4AW3-B	5M/T 4A/T	x x
	V46W	4M40 (2.8)	x	Single	-	x	Diesel S-RGS	V5M31-5	5M/T	x
L200	K65T	4G64-2 (2.4)	x	Single	x	-	MPI	R5M21-5 R4AW2-6	5M/T 4A/T	- -
	K66T	6G72-8 (3.0)	-	Double	x	-	MPI	R5M31-4	5M/T	-
	K67T	4M40 (2.8)	x	Single	-	-	Diesel S-RGS	R5M21-5	5M/T	-
	K76T	6G72-8 (3.0)	-	Double	x	-	MPI	V5MT1-4 V4AW3-6	5M/T 4A/T	x x
	K77T	4M40 (2.8)	x	Single	-	-	Diesel S-RGS	V5M21-9	5M/T	x
Challenger K96W		6G72-8 (3.0)	-	Double	x	-	MPI	V5MT1-4 V4AW3-6	5M/T 4A/T	x x

AUSTRALIA for 2000

Brand	Vehicle Model	Engine					Fuel System	Transmission		
		Model (lit.)	Silent shaft	Camshaft	Lash adjuster	Turbo charger		Model	Type	4WD
L300	P03V	4G63-A (2.0)	×	Single	×	–	CARB	R5M21-2 R4AW2-8	5M/T 4A/T	– –
	P03W	4G63-6 (2.0)	×	Single	×	–	MPI	R5M21-2 R4AW2-8	5M/T 4A/T	– –
	P05V P15V P15W	4D56-4 (2.5)	×	Single	–	×	Diesel S-RGS	R5M21-2	5M/T	–
	P15V	4G56-2 (2.5)	×	Single	–	–	Diesel S-RGS	R5M21-2	5M/T	–
	P14V	4G64-2 (2.4)	×	Single	×	–	MPI	R5M21-2 R4AW2-8	5M/T 4A/T	– –
	P04V P14W	4G64-2 (2.4)	×	Single	×	–	MPI	R5M21-2	5M/T	–
L400	PB4V	4G64-2 (2.4)	×	Single	×	–	MPI	R5M21-7 R4AW2-5	5M/T 4A/T	– –
	PA3W	4G63-6 (2.0)	×	Single	×	–	MPI	R5M21-7 R4AW2-5	5M/T 4A/T	– –
	PA4W	4G64-2 (2.4)	×	Single	×	–	MPI	R4AW2-5	4A/T	–

EUROPE for 2001

Brand	Vehicle Model	Engine					Fuel System	Transmission		
		Model (lit.)	Silent shaft	Camshaft	Lash adjuster	Turbo charger		Model	Type	4WD
Colt	CJ1A	4G13-6 (1.3)	–	Single	×	–	MPI	F5M41-1	5M/T	–
	CJ4A	4G92-3 (1.6)	–	Single	×	–	MPI	F5M41-1 F4A41-1	5M/T 4A/T	– –
	CK1A	4G13-3 (1.3)	–	Single	–	–	MPI	F5M41-1 F4A41-1	5M/T 4A/T	– –
Space Star	DG1A	4G13-6 (1.3)	–	Single	×	–	MPI	JB3-241	5M/T	–
	DG4A	F9QT-0 (1.9)	–	Single	–	–	Diesel S-RGS	F5MV1-1	5M/T	–
	DG5A	4G93-G (1.8)	–	Double	×	–	GDI	F5M42-1	5M/T	–
Carisma	DA1A	4G92-2 (1.6)	–	Single	×	–	MPI	JB3-242 F4A41-1	5M/T 4A/T	– –
	DA2A	4G93-G (1.8)	–	Double	×	–	GDI	F5M42-1 F4A42-1	5M/T 4A/T	– –
	DA5A	F9QT-0 (1.9)	–	Single	–	×	Diesel S-RGS	F5MV1-L	5M/T	–
		F9QT-1 (1.9)	–	Single	–	×	Diesel S-RGS	F5MV1-L	5M/T	–
Space Runner	N63W	4G63-F (2.0)	×	Single	×	–	MPI	F5M42-2 F4A42-1	5M/T 4A/T	– –
	N64W	4G64-4 (2.4)	×	Double	×	–	GDI	F5M42-2 F4A42-2	5M/T 4A/T	– –
Space Wagon	N83W	4G63-F (2.0)	×	Single	×	–	MPI	F5M42-2	5M/T	–
	N84W	4G64-4 (2.4)	×	Double	×	–	GDI	F5M42-2 F4A42-2	5M/T 4A/T	– –
	N94W	4G64-4 (2.4)	×	Double	×	–	GDI	W5M42-1	5M/T	×

EUROPE for 2001

Brand	Vehicle Model	Engine					Fuel System	Transmission		
		Model (lit.)	Silent shaft	Camshaft	Lash adjuster	Turbo charger		Model	Type	4WD
Galant	EA2A EA2W	4G63-6 (2.0)	×	Single	×	–	MPI	F5M42-2 F4A42-1	5M/T 4A/T	– –
	EA3A EA3W	4G64-4 (2.4)	×	Double	×	–	GDI	F5M42-2 F4A42-2	5M/T 4A/T	– –
	EA5A EA5W	6A13-4 (2.5)	–	Double	×	–	MPI	F5M42-2 F4A42-2	5M/T 4A/T	– –
Pajero/ Montero	V23C	6G72-8 (3.0)	–	Double	×	–	MPI	V5MT1-6 V4AW3-B	5M/T 4A/T	×
	V24C V24W V44W	4D56-4 (2.5)	×	Single	–	×	Diesel S-RGS	V5MT1-6	5M/T	×
	V64W V74W	4D56-4 (2.5)	×	Single	–	×	Diesel S-RGS	V5MT1-8 V5M31-6	5M/T 5M/T	×
	V65W V75W	6G74-B (3.5)	–	Four	×	–	GDI	V5M31-6 V5A51-7	5M/T 5A/T	×
	V68W V78W	4M41 (3.2)	×	Double	–	×	Diesel S-RGS	V5M31-6 V5A51-7	5M/T 5A/T	×
L200	K62T	4G63-6 (2.0)	×	Single	×	–	MPI	R5M21-5 R4AW2-6	5M/T 4A/T	– –
	K64T	4D56-4 (2.5)	×	Single	–	–	Diesel S-RGS	R5M21-5	5M/T	–
	K74T	4D56-4 (2.5)	×	Single	–	×	Diesel S-RGS	V5MT1-4 V4AW2-6	5M/T 4A/T	×
	K75T	4G64-2 (2.4)	×	Single	×	–	MPI	V5M21-9	5M/T	×
Pajero Sport	K94W	4D56-4 (2.5)	×	Single	–	×	Diesel S-RGS	V5MT1-B	5M/T	×
	K96W	6G72-8 (3.0)	–	Double	×	–	MPI	V5MT1-B V4A51-5	5M/T 4A/T	×
Pajero Pinin	H67W H77W	4G94-H (2.0)	–	Double	×	–	GDI	V5M21-A V4AW4-D	5M/T 4A/T	×

GENERAL EXPORT for 2001

Brand	Vehicle Model	Engine					Fuel System	Transmission		
		Model (lit.)	Silent shaft	Camshaft	Lash adjuster	Turbo charger		Model	Type	4WD
Colt	CJ1A	4G13-5 (1.3)	–	Single	–	–	CARB	F5M41-1	5M/T	–
	CJ2A	4G15-5 (1.5)	–	Single	–	–	CARB	F5M41-1 F4A41-1	5M/T 4A/T	– –
	CJ4A	4G92-3 (1.6)	–	Single	–	–	MPI	F5M41-1 F4A41-1	5M/T 4A/T	– –
Lancer	CS1A	4G13-6 (1.3)	–	Single	–	–	MPI	F5M41-1 F4A41-1	5M/T 4A/T	– –
		4G13-7 (1.3)	–	Single	–	–	CARB	F5M41-1 F4A41-1	5M/T 4A/T	– –
	CS2A	4G15-8 (1.5)	–	Double	×	–	GDI	F1C1A-1	CVT	–
	CS3A	4G18-6 (1.8)	–	Single	–	–	MPI	F5M41-1 F1C1A-1	5M/T CVT	– –
		4G18-7 (1.8)	–	Single	–	–	CARB	F5M41-1 F4A41-1	5M/T 4A/T	– –
	CS5A	4G93-G (1.8)	–	Double	×	–	GDI	F1C1A-2	CVT	–
Lancer Station Wagon	CB1W	4G13-2 (1.3)	–	Single	–	–	CARB	F5M21-1 F3A21-2	5M/T 3A/T	– –
	CB2W	4G15-2 (1.5)	–	Single	–	–	CARB	F5M21-1 F3A21-2	5M/T 3A/T	– –
	CB4W	4G92-0 (1.6)	–	Single	–	–	MPI	F5M22-2 F4A22-2	5M/T 4A/T	– –
Mirage Dingo	CQ2A	4G15-8 (1.5)	–	Double	×	–	GDI	F4A41-1	4A/T	–
Space Wagon	N84W	4G64-2 (2.4)	×	Single	×	–	MPI	F5M42-2 F4A42-2	5M/T 4A/T	– –
		4G64-4 (2.4)	×	Double	×	–	GDI	F4A42-2	4A/T	–

GENERAL EXPORT for 2001

Brand	Vehicle Model	Engine					Fuel System	Transmission		
		Model (lit.)	Silent shaft	Camshaft	Lash adjuster	Turbo charger		Model	Type	4WD
Galant	EA1A	4G93-9 (1.8)	–	Single	–	–	CARB	F5M42-1 F4A42-1	5M/T 4A/T	– –
	EA2A	4G63-E (2.0)	×	Single	×	–	CARB	F5M42-1 F4A42-1	5M/T 4A/T	– –
	EA2A EA2W	4G63-6 (2.0)	×	Single	×	–	MPI	F5M42-1 F4A42-1	5M/T 4A/T	– –
	EA3A	4G64-6 (2.4)	×	Double	×	–	GDI	F5A42-2	5A/T	–
	EA5A	6A13-4 (2.5)	–	Double	×	–	MPI	F5M42-2 F4A42-2	5M/T 4A/T	– –
	EA6A	4D68-2 (2.0)	×	Single	–	×	Diesel S-RGS	F5M42-2	5M/T	–
	EA7A	4G94-G (2.0)	–	Double	×	–	GDI	F4A42-1	4A/T	–
Pajero/ Montero	V11V V31V	4G64-6 (2.4)	×	Single	–	–	CARB	V5M21-6	5M/T	×
	V13V V33V	6G72-1 (3.0)	–	Double	×	–	MPI	V5MT1-6 V4AW2-7	5M/T 4A/T	×
	V14C	4D56-4 (2.5)	×	Single	–	–	Diesel S-RGS	V5M21-6	5M/T	×
	V14V V34V	4D56-4 (2.5)	×	Single	–	–	Diesel S-RGS	V5M21-6	5M/T	×
	V36V	4M40 (2.8)	×	Single	–	–	Diesel S-RGS	V5M21-6	5M/T	×
	V63W V73W	6G72-8 (3.0)	–	Double	×	–	MPI	V5MT1-8 V5M31-6 V4A51-7	5M/T 5M/T 4A/T	×
	V65W V75W	6G74-8 (3.5)	–	Double	×	–	MPI	V5M31-6 V5A51-7	5M/T 5A/T	×
		6G74-B (3.5)	–	Four	×	–	GDI	V4A51-7 V5A51-7	4A/T 5A/T	×

GENERAL EXPORT for 2001

Brand	Vehicle Model	Engine					Fuel System	Transmission		
		Model (lit.)	Silent shaft	Camshaft	Lash adjuster	Turbo charger		Model	Type	4WD
Pajero/ Montero	V66W V76W	4M40 (2.8)	×	Single	–	×	Diesel S-RGS	V5M31-6 V4A51-7	5M/T 4A/T	×
	V68W V78W	4M41 (3.2)	×	Double	–	×	Diesel S-RGS	V5M31-6 V5A51-7	5M/T 5A/T	×
L200	K62T	4G63-6 (2.0)	×	Single	×	–	MPI	R5M21-5	5M/T	–
			–	Single	×	–	CARB	R5M21-5	5M/T	–
		4G63-B (2.0)	–	Single	×	–	CARB	R5M21-5	5M/T	–
	K64T	4D56-3 (2.5)	×	Single	–	–	Diesel S-RGS	R5M21-5	5M/T	–
		4D56-4 (2.5)	×	Single	–	–	Diesel S-RGS	R5M21-5	5M/T	–
	K65T	4G64-2 (2.4)	×	Single	×	–	MPI	R5M21-5	5M/T	–
	K67T	4M40 (2.8)	×	Single	–	–	Diesel S-RGS	R5M21-5 R4AW2-6	5M/T 4A/T	–
	K72T	4G63-6 (2.0)	–	Single	×	–	CARB	V5M21-9	5M/T	×
		4G63-B (2.0)	–	Single	×	–	CARB	V5M21-9	5M/T	×
	K74T	4D56-3 (2.5)	×	Single	–	×	Diesel S-RGS	V5MT1-4	5M/T	×
			×	Single	–	–	Diesel S-RGS	V5M21-9	5M/T	×
		4D56-4 (2.5)	×	Single	–	–	Diesel S-RGS	V5M21-9	5M/T	×
		×	Single	–	×	Diesel S-RGS	V5MT1-4	5M/T	×	
	K75T	4G64-2 (2.4)	×	Single	×	–	MPI	V5M21-9	5M/T	×
	K77T	4M40 (2.8)	×	Single	–	–	Diesel S-RGS	V5M21-9	5M/T	×

GENERAL EXPORT for 2001

Brand	Vehicle Model	Engine					Fuel System	Transmission		
		Model (lit.)	Silent shaft	Camshaft	Lash adjuster	Turbo charger		Model	Type	4WD
Pajero io	H65W	4G18-9 (1.8)	–	Single	–	–	MPI	V5M21-A V4AW4-D	5M/T 4A/T	× ×
	H66W H76W	4G93-H (1.8)	–	Double	×	–	GDI	V5M21-A V4AW4-D	5M/T 4A/T	× ×
	H76W	4G93-D (1.8)	–	Single	–	–	MPI	V5M21-A V4AW4-D	5M/T 4A/T	× ×
Challenger	K86W	6G72-8 (3.0)	–	Double	×	–	MPI	R5M31-B R4A51-5	5M/T 4A/T	– –
	K96W	6G72-8 (3.0)	–	Double	×	–	MPI	V5MT1-B V4A51-5	5M/T 4A/T	× ×
	K97W	4M40 (2.8)	×	Single	–	×	Diesel S-RGS	V5M31-B V4A51-5	5M/T 4A/T	× ×
Sigma	F36A	6G72-5 (3.0)	–	Double	×	–	MPI	F4A51-2	4A/T	–

AUSTRALIA for 2001

Brand	Vehicle Model	Engine					Fuel System	Transmission		
		Model (lit.)	Silent shaft	Camshaft	Lash adjuster	Turbo charger		Model	Type	4WD
Colt	CJ2A	4G15-3 (1.5)	–	Single	–	–	MPI	F5M41-1 F4A41-1	5M/T 4A/T	– –
	CJ5A	4G93-3 (1.8)	–	Single	–	–	MPI	F5M42-1 F4A42-1	5M/T 4A/T	– –
Lancer Station Wagon	CB5W	4G93-0 (1.8)	–	Single	–	–	MPI	F5M22-2 F4A22-2	5M/T 4A/T	– –
Lancer	CK2A	4G15-3 (1.5)	–	Single	–	–	MPI	F5M41-1 F4A41-1	5M/T 4A/T	– –
	CK5A	4G93-3 (1.8)	–	Single	–	–	MPI	F5M42-1 F4A42-1	5M/T 4A/T	– –
Space Wagon	N84W	4G64-2 (2.4)	×	Single	×	–	MPI	F5M42-2 F4A42-2	5M/T 4A/T	– –
Pajero/ Montero	V75W	6G74-8 (3.5)	–	Double	×	–	MPI	V5M31-6 V5A51-7	5M/T 5A/T	×
	V76W	4M40 (2.8)	×	Single	–	×	Diesel S-RGS	V5M31-6	5M/T	×
Pajero io	H65W	4G18-9 (1.8)	–	Single	–	–	MPI	V5M21-A	5M/T	×
	H76W	4G93-D (1.8)	–	Single	–	–	MPI	V5M21-A V4AW4-D	5M/T 4A/T	×
L200	K65T	4G64-2 (2.4)	×	Single	×	–	MPI	R5M21-5	5M/T	–
	K66T	6G72-8 (3.0)	–	Double	×	–	MPI	R5M31-4 R4A51-4	5M/T 4A/T	– –
	K76T	6G72-8 (3.0)	–	Double	×	–	MPI	V5MT1-4 V4A51-4	5M/T 4A/T	×
	K77T	4M40 (2.8)	×	Single	–	–	Diesel S-RGS	V5M21-9	5M/T	×
Challenger K96W		6G72-8 (3.0)	–	Double	×	–	MPI	V5MT1-4 V4A51-4	5M/T 4A/T	×

AUSTRALIA for 2001

Brand	Vehicle Model	Engine					Fuel System	Transmission		
		Model (lit.)	Silent shaft	Camshaft	Lash adjuster	Turbo charger		Model	Type	4WD
Sigma	F36A	6G72-5 (3.0)	–	Double	×	–	MPI	F5M51-1 F4A51-2	5M/T 4A/T	– –
	F38A	6G74-5 (3.5)	–	Double	×	–		MPI	F5M51-1 F4A51-2 F5A51-2	5M/T 4A/T 5A/T
Magna	F36W	6G72-5 (3.0)	–	Double	×	–	MPI		F5M51-1 F4A51-2	5M/T 4A/T
	F38W	6G74-5 (3.5)	–	Double	×	–		MPI	F5M51-1 F4A51-2	5M/T 4A/T

EUROPE for 2002

Brand	Vehicle Model	Engine					Fuel System	Transmission		
		Model (lit.)	Silent shaft	Camshaft	Lash adjuster	Turbo charger		Model	Type	4WD
Colt	CJ1A	4G13-6 (1.3)	–	Single	×	–	MPI	F5M41-1	5M/T	–
	CJ4A	4G92-3 (1.6)	–	Single	×	–	MPI	F5M41-1 F4A41-1	5M/T 4A/T	– –
Space Star	DG1A	4G13-6 (1.3)	–	Single	×	–	MPI	JB3-241	5M/T	–
	DG3A	4G18-6 (1.6)	–	Single	×	–	MPI	JB3-244 F4A41-1	5M/T 4A/T	– –
	DG4A	F9QT-0 (1.9)	–	Single	–	–	Diesel S-RGS	F5MV1-L	5M/T	–
	DG5A	4G93-G (1.8)	–	Double	×	–	GDI	F5M42-1 F4A42-1	5M/T 4A/T	– –
Carisma	DA1A	4G92-2 (1.6)	–	Single	×	–	MPI	JB3-243 F4A41-1	5M/T 4A/T	– –
	DA2A	4G93-G (1.8)	–	Double	×	–	GDI	F5M42-1 F4A42-1	5M/T 4A/T	– –
	DA5A	F9QT-0 (1.9)	–	Single	–	×	Diesel S-RGS	F5MV1-L	5M/T	–
		F9QT-1 (1.9)	–	Single	–	×	Diesel S-RGS	F5MV1-L	5M/T	–
	DA6A	4G13-6 (1.3)	–	Single	×	–	MPI	JB3-308	5M/T	–
Space Wagon	N83W	4G63-F (2.0)	×	Single	×	–	MPI	F5M42-2	5M/T	–
	N84W	4G64-4 (2.4)	×	Double	×	–	GDI	F5M42-2 F4A42-2	5M/T 4A/T	– –
	N94W	4G64-4 (2.4)	×	Double	×	–	GDI	W5M42-1	5M/T	×

EUROPE for 2002

Brand	Vehicle Model	Engine					Fuel System	Transmission		
		Model (lit.)	Silent shaft	Camshaft	Lash adjuster	Turbo charger		Model	Type	4WD
Pajero/ Montero	V24W V44W	4D56-5 (2.5)	×	Single	–	×	Diesel S-RGS	V5MT1-6	5M/T	×
	V64W V74W	4D56-5 (2.5)	×	Single	–	×	Diesel S-RGS	V5MT1-8 V5M31-6	5M/T 5M/T	×
	V65W V75W	6G74-B (3.5)	–	Four	×	–	GDI	V5M31-6 V5A51-7	5M/T 5A/T	×
	V68W V78W	4M41 (3.2)	×	Double	–	×	Diesel S-RGS	V5M31-6 V5A51-7	5M/T 5A/T	×
L200	K64T	4D56-4 (2.5)	×	Single	–	–	Diesel S-RGS	R5M21-5	5M/T	–
		4D56-5 (2.5)	×	Single	–	×	Diesel S-RGS	R5M21-5 R4AW2-6	5M/T 4A/T	–
	K74T	4D56-4 (2.5)	×	Single	–	×	Diesel S-RGS	V5MT1-4 V4AW2-6	5M/T 4A/T	×
		4D56-5 (2.5)	×	Single	–	×	Diesel S-RGS	V5MT1-4 V4AW2-6	5M/T 4A/T	×
	K75T	4G64-2 (2.4)	×	Single	×	–	MPI	V5M21-9	5M/T	×
Pajero Sport	K94W	4D56-4 (2.5)	×	Single	–	×	Diesel S-RGS	V5MT1-B	5M/T	×
		4D56-5 (2.5)	×	Single	–	×	Diesel S-RGS	V5MT1-D	5M/T	×
	K96W	6G72-8 (3.0)	–	Double	×	–	MPI	V5MT1-D V4A51-5	5M/T 4A/T	×
Pajero Pinin	H66W H76W	4G93-D (1.8)	–	Single	×	–	MPI	V5M21-A V4AW4-D	5M/T 4A/T	×
	H67W H77W	4G94-H (2.0)	–	Double	×	–	GDI	V5M21-A V4AW4-D	5M/T 4A/T	×

EUROPE for 2002

Brand	Vehicle Model	Engine					Fuel System	Transmission		
		Model (lit.)	Silent shaft	Camshaft	Lash adjuster	Turbo charger		Model	Type	4WD
L300	P03V P13V	4G63-6 (2.0)	×	Single	×	–	MPI	R5M21-2	5M/T	–
	P05V P15V	4D56-4 (2.5)	×	Single	–	–	Diesel S-RGS	R5M21-2	5M/T	–
	P45V	4D56-4 (2.5)	×	Single	–	×	Diesel S-RGS	V5M21-2	5M/T	×
L400	PA3V PB3V	4G63-6 (2.0)	×	Single	×	–	MPI	R5M21-7	5M/T	–
	PA5V PB5V	4D56-4 (2.5)	×	Single	–	×	Diesel S-RGS	R5M21-7	5M/T	–
	PD4V	4G64-2 (2.4)	×	Single	×	–	MPI	V5M21-7	5M/T	×
	PD5V	4D56-4 (2.5)	×	Single	–	×	Diesel S-RGS	V5M21-7	5M/T	×
Space Gear	PA3W	4G63-6 (2.0)	×	Single	×	–	MPI	R5M21-7	5M/T	–
	PA4W	4G64-2 (2.4)	×	Single	×	–	MPI	R5M21-7 R4AW2-5	5M/T 4A/T	– –
	PA5W	4D56-4 (2.5)	×	Single	–	×	Diesel S-RGS	R5M31-7	5M/T	–
	PD4W	4G64-2 (2.4)	×	Single	×	–	MPI	V5M21-7	5M/T	×
	PD5W	4D56-4 (2.5)	×	Single	–	×	Diesel S-RGS	V5M31-7	5M/T	×

GENERAL EXPORT for 2002

Brand	Vehicle Model	Engine					Fuel System	Transmission		
		Model (lit.)	Silent shaft	Camshaft	Lash adjuster	Turbo charger		Model	Type	4WD
Colt	CJ1A	4G13-5 (1.3)	–	Single	–	–	CARB	F5M41-1	5M/T	–
	CJ2A	4G15-5 (1.5)	–	Single	–	–	CARB	F5M41-1 F4A41-1	5M/T 4A/T	– –
	CJ4A	4G92-3 (1.6)	–	Single	–	–	MPI	F5M41-1 F4A41-1	5M/T 4A/T	– –
Lancer	CS1A	4G13-6 (1.3)	–	Single	–	–	MPI	F5M41-1 F4A41-1	5M/T 4A/T	– –
		4G13-7 (1.3)	–	Single	–	–	CARB	F5M41-1 F4A41-1	5M/T 4A/T	– –
	CS2A	4G15-8 (1.5)	–	Double	×	–	GDI	F1C1A-1	CVT	–
	CS3A	4G18-6 (1.6)	–	Single	–	–	MPI	F5M41-1 F1C1A-1	5M/T CVT	– –
		4G18-7 (1.6)	–	Single	–	–	CARB	F5M41-1 F4A41-1	5M/T 4A/T	– –
CS5A	4G93-G (1.8)	–	Double	×	–	GDI	F1C1A-1	CVT	–	
Lancer Station Wagon	CB1W	4G13-2 (1.3)	–	Single	–	–	CARB	F5M21-1 F3A21-2	5M/T 3A/T	– –
	CB2W	4G15-2 (1.5)	–	Single	–	–	CARB	F5M21-1 F3A21-2	5M/T 3A/T	– –
	CB4W	4G92-0 (1.6)	–	Single	–	–	MPI	F5M22-2 F4A22-2	5M/T 4A/T	– –
Space Wagon	N84W	4G64-2 (2.4)	×	Single	×	–	MPI	F5M42-2 F4A42-2	5M/T 4A/T	– –
		4G64-4 (2.4)	×	Double	×	–	GDI	F4A42-2	4A/T	–
Galant	EA1A	4G93-9 (1.8)	–	Single	–	–	CARB	F5M42-1 F4A42-1	5M/T 4A/T	– –
	EA2A	4G63-E (2.0)	×	Single	×	–	CARB	F5M42-1 F4A42-1	5M/T 4A/T	– –

GENERAL EXPORT for 2002

Brand	Vehicle Model	Engine					Fuel System	Transmission			
		Model (lit.)	Silent shaft	Camshaft	Lash adjuster	Turbo charger		Model	Type	4WD	
Galant	EA2A EA2W	4G63-6 (2.0)	×	Single	×	–	MPI	F5M42-1	5M/T	–	
			–	–	–	F4A42-1		4A/T	–		
	EA5A	6A13-4 (2.5)	–	Double	×	–	MPI	F5M42-2	5M/T	–	
								F4A42-2	4A/T	–	
	EA6A	4D68-2 (2.0)	×	Single	–	×	Diesel S-RGS	F5M42-2	5M/T	–	
	EA7A	4G94-G (2.0)	–	Double	×	–	GDI	F4A42-1	4A/T	–	
Pajero/ Montero	V11V V31V	4G64-6 (2.4)	×	Single	–	–	CARB	V5M21-6	5M/T	×	
	V33V	6G72-1 (3.0)	–	Double	×	–	MPI	V5MT1-6	5M/T	×	
			–	–	–	V4AW2-7	4A/T	×			
			6G72-8 (3.0)	–	Double	×	–	MPI	V5MT1-6	5M/T	×
				–	–	–	–	V4AW3-7	4A/T	×	
	V14V V34V	4D56-4 (2.5)	×	Single	–	–	Diesel S-RGS	V5M21-6	5M/T	×	
	V36V	4M40 (2.8)	×	Single	–	–	Diesel S-RGS	V5M21-6	5M/T	×	
	V63W V73W	6G72-8 (3.0)	–	Double	×	–	MPI	V5MT1-8	5M/T	×	
								V5M31-6	5M/T	×	
								V4A51-7	4A/T	×	
V65W V75W	6G74-8 (3.5)	–	Double	×	–	MPI	V5M31-6	5M/T	×		
							V5A51-7	5A/T	×		
		6G74-B (3.5)	–	Four	×	–	GDI	V5A51-7	5A/T	×	
V66W V76W	4M40 (2.8)	×	Single	–	×	Diesel S-RGS	V5M31-6	5M/T	×		
							V4A51-7	4A/T	×		
V78W	4M41 (3.2)	×	Double	–	×	Diesel S-RGS	V5M31-6	5M/T	×		
							V5A51-7	5A/T	×		
L200	K62T	4G63-6 (2.0)	×	Single	×	–	MPI	R5M21-5	5M/T	–	
			–	–	–	CARB	R5M21-5	5M/T	–		
	K64T	4D56-4 (2.5)	×	Single	–	–	Diesel S-RGS	R5M21-5	5M/T	–	

GENERAL EXPORT for 2002

Brand	Vehicle Model	Engine					Fuel System	Transmission		
		Model (lit.)	Silent shaft	Camshaft	Lash adjuster	Turbo charger		Model	Type	4WD
L200	K65T	4G64-2 (2.4)	×	Single	×	–	MPI	R5M21-5	5M/T	–
	K67T	4M40 (2.8)	×	Single	–	–	Diesel S-RGS	R5M21-5	5M/T	–
	K72T	4G63-6 (2.0)	–	Single	×	–	CARB	V5M21-9	5M/T	×
	K74T	4D56-4 (2.5)	×	Single	–	–	Diesel S-RGS	V5M21-9	5M/T	×
			×	Single	–	×	Diesel S-RGS	V5MT1-4	5M/T	×
	K75T	4G64-2 (2.4)	×	Single	×	–	MPI	V5M21-9	5M/T	×
	K77T	4M40 (2.8)	×	Single	–	–	Diesel S-RGS	V5M21-9	5M/T	×
Pajero iO	H67W H77W	4G94-D (2.0)	–	Single	–	–	MPI	V5M21-A V4AW-D	5M/T 4A/T	×
			–	Double	×	×	GDI	V4AW5-D	4A/T	×
Challenger	K86W	6G72-8 (3.0)	–	Double	×	–	MPI	R5M31-B R4A51-5	5M/T 4A/T	– –
	K96W	6G72-8 (3.0)	–	Double	×	–	MPI	V5MT1-D V4A51-5	5M/T 4A/T	×
	K97W	4M40 (2.8)	×	Single	–	×	Diesel S-RGS	V5M31-B V4A51-5	5M/T 4A/T	×
L300	P03V P13V	4G63-B (2.0)	–	Single	×	–	CARB	R5M21-2	5M/T	–
	P03W P13W	4G63-B (2.0)	–	Single	×	–	CARB	R5M21-2 R4AW2-8	5M/T 4A/T	– –
	P06V P16V	4G92-0 (1.6)	–	Single	–	–	CARB	R5M21-2	5M/T	–

GENERAL EXPORT for 2002

Brand	Vehicle Model	Engine					Fuel System	Transmission		
		Model (lit.)	Silent shaft	Camshaft	Lash adjuster	Turbo charger		Model	Type	4WD
L300	P13V P13W	4G63-6 (2.0)	×	Single	×	–	MPI	R5M21-2	5M/T	–
	P15V P15W	4D56-2 (2.5)	×	Single	–	–	Diesel S-RGS	R5M21-2	5M/T	–
	P15V	4D56-4 (2.5)	×	Single	–	–	Diesel S-RGS	R5M21-2	5M/T	–
	P23W	4G63-B (2.0)	–	Single	×	–	CARB	V5M21-2	5M/T	×
L400	PB3V	4G63-B (2.0)	–	Single	×	–	CARB	R5M21-7	5M/T	–
	PB5V	4D56-4 (2.5)	×	Single	–	×	Diesel S-RGS	R5M21-7	5M/T	–
Space Gear	PA3W	4G63-B (2.0)	–	Single	×	–	CARB	R4AW2-5	4A/T	–
	PA4W	4G64-2 (2.4)	×	Single	×	–	MPI	R4AW2-5	4A/T	–
	PA5W PC5W	4D56-4 (2.5)	×	Single	–	×	Diesel S-RGS	R5M21-7	5M/T	–
	PC3W	4G63-B (2.0)	–	Single	×	–	CARB	R5M21-7	5M/T	–
	PD3W	4G63-B (2.0)	–	Single	×	–	CARB	V5M21-7	5M/T	×
	PD4W	4G64-2 (2.4)	×	Single	×	–	MPI	V5M21-7	5M/T	×
	PD5W	4D56-4 (2.5)	×	Single	–	×	Diesel S-RGS	V5M21-7	5M/T	×
Sigma	F38A	6G74-5 (3.5)	–	Double	×	–	MPI	F5M51-1 F4A51-2	5M/T 4A/T	– –

AUSTRALIA for 2002

Brand	Vehicle Model	Engine					Fuel System	Transmission		
		Model (lit.)	Silent shaft	Camshaft	Lash adjuster	Turbo charger		Model	Type	4WD
Colt	CJ2A	4G15-3 (1.5)	–	Single	–	–	MPI	F5M41-1 F4A41-1	5M/T 4A/T	– –
	CJ5A	4G93-3 (1.8)	–	Single	–	–	MPI	F5M42-1 F4A42-1	5M/T 4A/T	– –
Lancer Station Wagon	CB5W	4G93-0 (1.8)	–	Single	–	–	MPI	F5M22-2 F4A22-2	5M/T 4A/T	– –
Lancer	CK5A	4G93-3 (1.8)	–	Single	–	–	MPI	F5M42-1 F4A42-1	5M/T 4A/T	– –
	CS6A	4G94-3 (2.0)	–	Single	–	–	MPI	F5M42-1 F4A42-1	5M/T 4A/T	– –
Space Wagon	N84W	4G64-2 (2.4)	×	Single	×	–	MPI	F5M42-2 F4A42-2	5M/T 4A/T	– –
Pajero/ Montero	V75W	6G74-8 (3.5)	–	Double	×	–	MPI	V5M31-6 V5A51-7	5M/T 5A/T	×
	V76W	4M40 (2.8)	×	Single	–	×	Diesel S-RGS	V5M31-6	5M/T	×
	V78W	4M41 (3.2)	×	Double	–	×	Diesel S-RGS	V5M31-6 V5A51-7	5M/T 5A/T	×
L200	K65T	4G64-2 (2.4)	×	Single	×	–	MPI	R5M21-5	5M/T	–
	K66T	6G72-8 (3.0)	–	Double	×	–	MPI	R5M31-4 R4A51-4	5M/T 4A/T	– –
	K76T	6G72-8 (3.0)	–	Double	×	–	MPI	V5MT1-C V4A51-4	5M/T 4A/T	×
	K77T	4M40 (2.8)	×	Single	–	–	Diesel S-RGS	V5M21-9	5M/T	×
Challenger K96W		6G72-8 (3.0)	–	Double	×	–	MPI	V5MT1-D V4A51-5	5M/T 4A/T	×
Pajero iO	H67W H77W	4G94D (2.0)	–	Single	–	–	MPI	V5M21-A V4AW4-D	5M/T 4A/T	×

AUSTRALIA for 2002

Brand	Vehicle Model	Engine					Fuel System	Transmission		
		Model (lit.)	Silent shaft	Camshaft	Lash adjuster	Turbo charger		Model	Type	4WD
L300	P03V	4G63-A (2.0)	×	Single	×	–	CARB	R5M21-2 R4AW2-8	5M/T 4A/T	– –
	P03W	4G63-6 (2.0)	×	Single	×	–	MPI	R5M21-2 R4AW2-8	5M/T 4A/T	– –
	P05V P15V P15W	4D56-4 (2.5)	×	Single	–	×	Diesel S-RGS	R5M21-2	5M/T	–
	P15V	4D56-2 (2.5)	×	Single	–	–	Diesel S-RGS	R5M21-2	5M/T	–
	P14V	4G64-2 (2.4)	×	Single	×	–	MPI	R5M21-2 R4AW2-8	5M/T 4A/T	– –
	P04V P14W	4G64-2 (2.4)	×	Single	×	–	MPI	R5M21-2	5M/T	–
L400	PB4V	4G64-2 (2.4)	×	Single	×	–	MPI	R5M21-7 R4AW2-5	5M/T 4A/T	– –
Space Gear	PA3W	4G63-6 (2.0)	×	Single	×	–	MPI	R5M21-7 R4AW2-5	5M/T 4A/T	– –
	PA4W	4G64-2 (2.4)	×	Single	×	–	MPI	R4AW2-5	4A/T	–

EUROPE for 2003

Brand	Vehicle Model	Engine					Fuel System	Transmission		
		Model (lit.)	Silent shaft	Camshaft	Lash adjuster	Turbo charger		Model	Type	4WD
Colt	CJ1A	4G13-6 (1.3)	–	Single	×	–	MPI	F5M41-1	5M/T	–
	CJ4A	4G92-3 (1.6)	–	Single	×	–	MPI	F5M41-1 F4A41-1	5M/T 4A/T	– –
Space Star	DG1A	4G13-6 (1.3)	–	Single	×	–	MPI	JB3-241	5M/T	–
	DG3A	4G18-6 (1.6)	–	Single	×	–	MPI	JB3-244 F4A41-1	5M/T 4A/T	– –
	DG4A	F9QT-0 (1.9)	–	Single	–	–	Diesel S-RGS	F5MV1-L	5M/T	–
		F9QT-1 (1.9)	–	Single	–	–	Diesel S-RGS	F5MV1-L	5M/T	–
	DG5A	4G93-3 (1.8)	–	Single	×	–	MPI	JB3-241 F4A42-1	5M/T 4A/T	– –
Carisma	DA1A	4G92-2 (1.6)	–	Single	×	–	MPI	JB3-243 F4A41-1	5M/T 4A/T	– –
	DA2A	4G93-G (1.8)	–	Double	×	–	GDI	F5M42-1 F4A42-1	5M/T 4A/T	– –
	DA5A	F9QT-0 (1.9)	–	Single	–	×	Diesel S-RGS	F5MV1-L	5M/T	–
		F9QT-1 (1.9)	–	Single	–	×	Diesel S-RGS	F5MV1-L	5M/T	–
	DA6A	4G13-6 (1.3)	–	Single	×	–	MPI	JB3-308	5M/T	–
Space Wagon	N83W	4G63-F (2.0)	×	Single	×	–	MPI	F5M42-2	5M/T	–
	N84W	4G64-4 (2.4)	×	Double	×	–	GDI	F5M42-2 F4A42-2	5M/T 4A/T	– –
	N94W	4G64-4 (2.4)	×	Double	×	–	GDI	W5M42-1	5M/T	×

EUROPE for 2003

Brand	Vehicle Model	Engine					Fuel System	Transmission			
		Model (lit.)	Silent shaft	Camshaft	Lash adjuster	Turbo charger		Model	Type	4WD	
Pajero/ Montero	V64W V74W	4D56-5 (2.5)	×	Single	–	×	Diesel S-RGS	V5MT1-8 V5M31-6	5M/T 5M/T	×	×
	V65W V75W	6G74-B (3.5)	–	Four	×	–	GDI	V5M31-6 V5A51-7	5M/T 5A/T	×	×
	V68W V78W	4M41 (3.2)	×	Double	–	×	Diesel S-RGS	V5M31-6 V5A51-7	5M/T 5A/T	×	×
L200	K64T	4D56-4 (2.5)	×	Single	–	–	Diesel S-RGS	R5M21-5	5M/T	–	–
		4D56-5 (2.5)	×	Single	–	×	Diesel S-RGS	R5M21-5 R4AW2-6	5M/T 4A/T	–	–
	K74T	4D56-4 (2.5)	×	Single	–	×	Diesel S-RGS	V5MT1-4 V4AW2-6	5M/T 4A/T	×	×
		4D56-5 (2.5)	×	Single	–	×	Diesel S-RGS	V5MT1-4 V4AW2-6	5M/T 4A/T	×	×
	K75T	4G64-2 (2.4)	×	Single	×	–	MPI	V5M21-9	5M/T	×	×
Pajero Sport	K94W	4D56-4 (2.5)	×	Single	–	×	Diesel S-RGS	V5MT1-B	5M/T	×	×
		4D56-5 (2.5)	×	Single	–	×	Diesel S-RGS	V5MT1-D	5M/T	×	×
	K96W	6G72-8 (3.0)	–	Double	×	–	MPI	V5MT1-D V4A51-5	5M/T 4A/T	×	×
Pajero Pinin	H66W H76W	4G93-D (1.8)	–	Single	×	–	MPI	V5M21-A V4AW4-D	5M/T 4A/T	×	×
	H67W H77W	4G94-H (2.0)	–	Double	×	–	GDI	V5M21-A V4AW4-D	5M/T 4A/T	×	×

GENERAL EXPORT for 2003

Brand	Vehicle Model	Engine					Fuel System	Transmission		
		Model (lit.)	Silent shaft	Camshaft	Lash adjuster	Turbo charger		Model	Type	4WD
Colt	CJ1A	4G13-5 (1.3)	–	Single	–	–	CARB	F5M41-1	5M/T	–
	CJ2A	4G15-5 (1.5)	–	Single	–	–	CARB	F5M41-1 F4A41-1	5M/T 4A/T	– –
	CJ4A	4G92-3 (1.6)	–	Single	–	–	MPI	F5M41-1 F4A41-1	5M/T 4A/T	– –
Lancer	CS1A	4G13-6 (1.3)	–	Single	–	–	MPI	F5M41-1 F4A41-1	5M/T 4A/T	– –
	CS3A	4G18-6 (1.6)	–	Single	–	–	MPI	F5M41-1 F1C1A-1	5M/T CVT	– –
Lancer Station Wagon	CB1W	4G13-2 (1.3)	–	Single	–	–	CARB	F5M21-1 F3A21-2	5M/T 3A/T	– –
	CB2W	4G15-2 (1.5)	–	Single	–	–	CARB	F5M21-1 F3A21-2	5M/T 3A/T	– –
	CB4W	4G92-0 (1.6)	–	Single	–	–	MPI	F5M22-2 F4A22-2	5M/T 4A/T	– –
Space Wagon	N84W	4G64-2 (2.4)	×	Single	×	–	MPI	F5M42-2 F4A42-2	5M/T 4A/T	– –
		4G64-4 (2.4)	×	Double	×	–	GDI	F4A42-2	4A/T	–

GENERAL EXPORT for 2003

Brand	Vehicle Model	Engine					Fuel System	Transmission		
		Model (lit.)	Silent shaft	Camshaft	Lash adjuster	Turbo charger		Model	Type	4WD
Pajero/ Montero	V11V V31V	4G64-6 (2.4)	×	Single	–	–	CARB	V5M21-6	5M/T	×
	V14V V34V	4D56-4 (2.5)	×	Single	–	–	Diesel S-RGS	V5M21-6	5M/T	×
	V36V	4M40 (2.8)	×	Single	–	–	Diesel S-RGS	V5M21-6	5M/T	×
	V63W V73W	6G72-8 (3.0)	–	Double	×	–	MPI	V5MT1-9 V5M31-6 V4A51-7	5M/T 5M/T 4A/T	×
	V65W V75W	6G74-8 (3.5)	–	Double	×	–	MPI	V5M31-6 V5A51-7	5M/T 5A/T	×
	V66W V76W	4M40 (2.8)	×	Single	–	×	Diesel S-RGS	V5M31-6 V4A51-7	5M/T 4A/T	×
	V75W	6G74-B (3.5)	–	Four	×	–	GDI	V5A51-7	5A/T	×
	V78W	4M41 (3.2)	×	Double	–	×	Diesel S-RGS	V5M31-6 V5A51-7	5M/T 5A/T	×
L200	K62T	4G63-6 (2.0)	×	Single	×	–	MPI	R5M21-5	5M/T	–
		4G63-B (2.0)	–	Single	×	–	CARB	R5M21-5	5M/T	–
	K64T	4D56-4 (2.5)	×	Single	–	–	Diesel S-RGS	R5M21-5	5M/T	–
	K65T	4G64-2 (2.4)	×	Single	×	–	MPI	R5M21-5	5M/T	–

GENERAL EXPORT for 2003

Brand	Vehicle Model	Engine					Fuel System	Transmission		
		Model (lit.)	Silent shaft	Camshaft	Lash adjuster	Turbo charger		Model	Type	4WD
L200	K67T	4M40 (2.8)	×	Single	–	–	Diesel S-RGS	R5M21-5	5M/T	–
	K72T	4G63-G (2.0)	–	Single	×	–	CARB	V5M21-9	5M/T	×
	K74T	4D56-4 (2.5)	×	Single	–	–	Diesel S-RGS	V5M21-9	5M/T	×
			×	Single	–	×	Diesel S-RGS	V5MT1-4	5M/T	×
	K75T	4G64-2 (2.4)	×	Single	×	–	MPI	V5M21-9	5M/T	×
	K77T	4M40 (2.8)	×	Single	–	–	Diesel S-RGS	V5M21-9	5M/T	×
Challenger	K86W	6G72-8 (3.0)	–	Double	×	–	MPI	R5M31-B R4A51-5	5M/T 4A/T	– –
	K96W	6G72-8 (3.0)	–	Double	×	–	MPI	V5MT1-D V4A51-5	5M/T 4A/T	×
	K97W	4M40 (2.8)	×	Single	–	×	Diesel S-RGS	V5M31-B V4A51-5	5M/T 4A/T	×
Sigma	F38A	6G74-5 (3.5)	–	Double	×	–	MPI	F5M51-1 F4A51-2	5M/T 4A/T	– –

AUSTRALIA for 2003

Brand	Vehicle Model	Engine					Fuel System	Transmission		
		Model (lit.)	Silent shaft	Camshaft	Lash adjuster	Turbo charger		Model	Type	4WD
Colt	CJ2A	4G15-3 (1.5)	–	Single	–	–	MPI	F5M41-1 F4A41-1	5M/T 4A/T	– –
	CJ5A	4G93-3 (1.8)	–	Single	–	–	MPI	F5M42-1 F4A42-1	5M/T 4A/T	– –
Lancer Station Wagon	CB5W	4G93-0 (1.8)	–	Single	–	–	MPI	F5M22-2 F4A22-2	5M/T 4A/T	– –
Lancer	CK5A	4G93-3 (1.8)	–	Single	–	–	MPI	F5M42-1 F4A42-1	5M/T 4A/T	– –
	CS6A	4G94-3 (2.0)	–	Single	–	–	MPI	F5M42-1 F4A42-1	5M/T 4A/T	– –
Space Wagon	N84W	4G64-2 (2.4)	×	Single	×	–	MPI	F5M42-2 F4A42-2	5M/T 4A/T	– –
Pajero/ Montero	V75W	6G74-8 (3.5)	–	Double	×	–	MPI	V5M31-6 V5A51-7	5M/T 5A/T	×
	V76W	4M40 (2.8)	×	Single	–	×	Diesel S-RGS	V5M31-6 V5A51-7	5M/T 5A/T	×
L200	K65T	4G64-2 (2.4)	×	Single	×	–	MPI	R5M21-5	5M/T	–
	K66T	6G72-8 (3.0)	–	Double	×	–	MPI	R5M31-4 R4A51-4	5M/T 4A/T	– –
	K76T	6G72-8 (3.0)	–	Double	×	–	MPI	V5MT1-C V4A51-4	5M/T 4A/T	×
	K77T	4M40 (2.8)	×	Single	–	–	Diesel S-RGS	V5M21-9	5M/T	×
			×	Single	–	×	Diesel S-RGS	V5M31-C	5M/T	×
Challenger K96W	6G72-8 (3.0)	–	Double	×	–	MPI	V5MT1-D V4A51-5	5M/T 4A/T	×	

2. ENGINE MODEL AND SERIAL NUMBER

ENGINE MODEL AND SERIAL NUMBER LOCATION

- (1) Stamped engine model and serial number are located as illustrated.
- (2) All engine serial numbers contain six digits as follows:

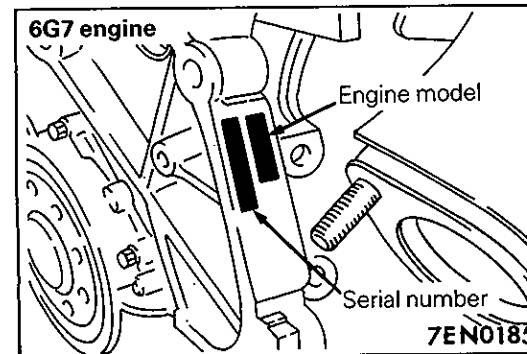
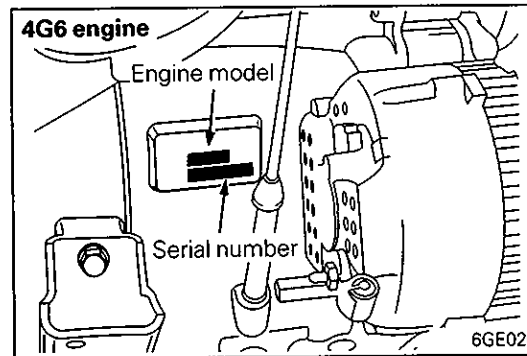
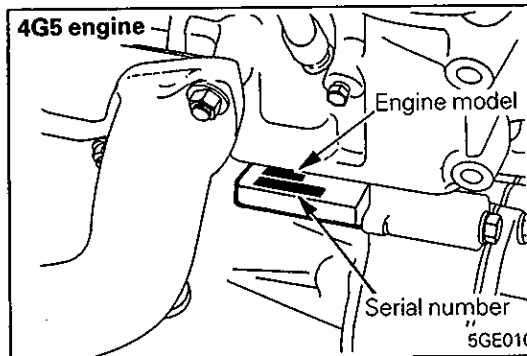
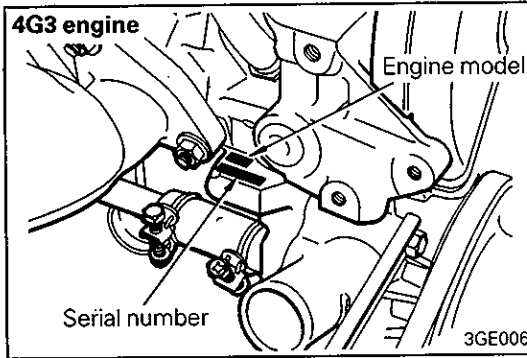
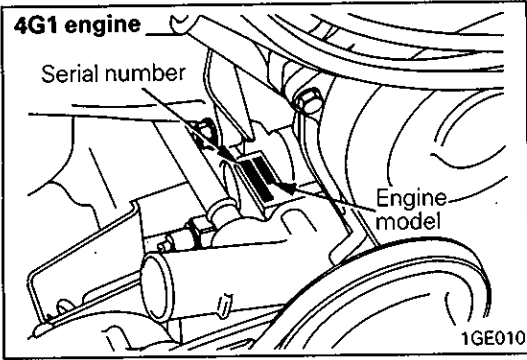
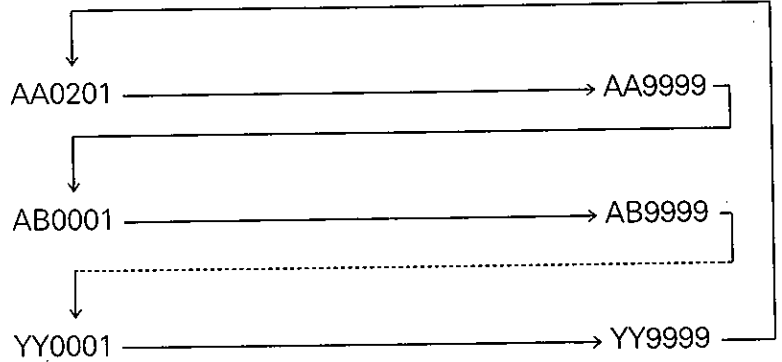

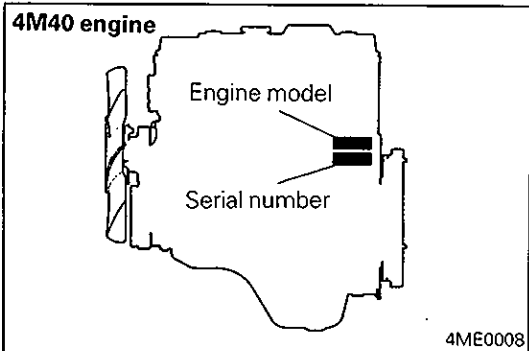
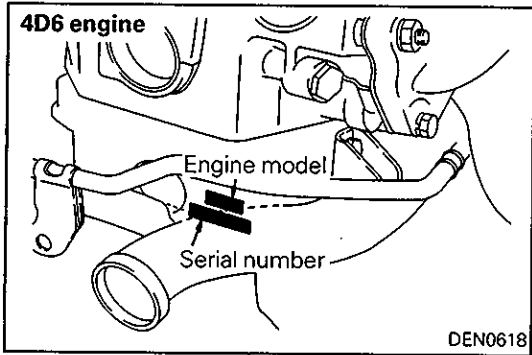
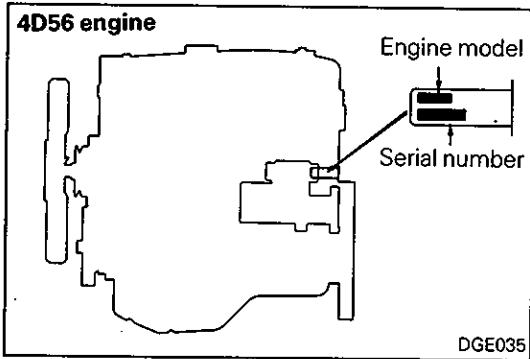
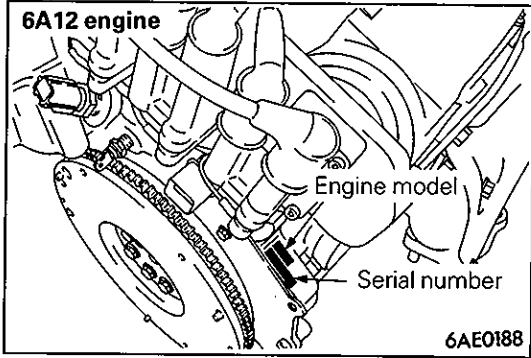
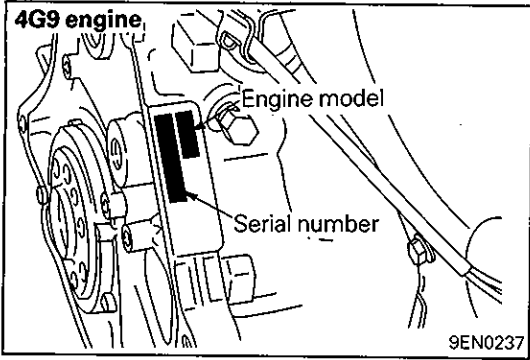

3. PRECAUTIONS BEFORE SERVICE

When the engine or transmission is disassembled and reassembled, pay attention to the following.

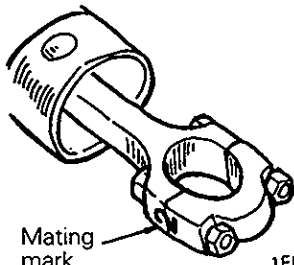
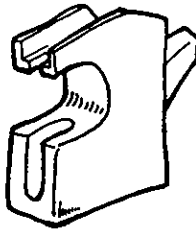
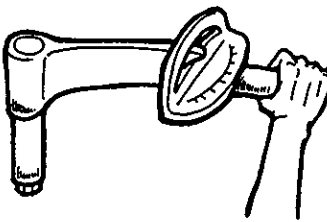
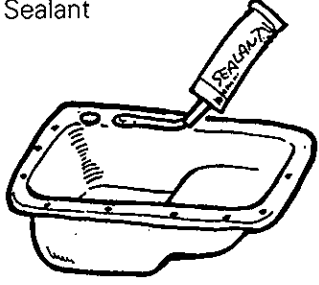
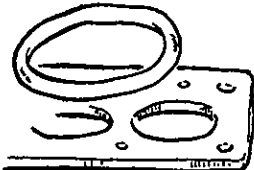
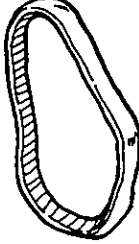
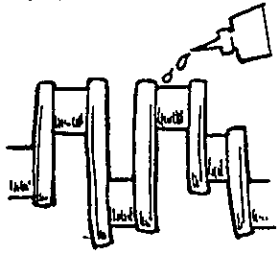
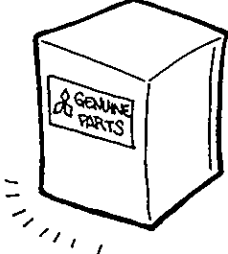
<p>Removal and Disassembly</p>  <p>Mating mark 1EN0018</p>	<p>For prevention of wrong installation or reassembly and for ease of operation, put mating marks to the parts where no function is adversely affected.</p>	<p>Special Tool</p>  <p>1EN0019</p>	<p>Be sure to use Special Tools when their use is specified for the operation. Use of substitute tools will result in malfunction of the part or damage it.</p>
<p>Tightening Torque</p>  <p>1EN0020</p>	<p>Tighten the part properly to specified torque.</p>	<p>Sealant</p>  <p>1EN0021</p>	<p>Use specified brand of sealant. Use of sealant other than specified sealant may cause water or oil leaks.</p>
<p>Replacement Part</p>  <p>1EN0022</p>	<p>When oil seal, O-ring, packing and gasket have been removed, be sure to replace them with new parts. However, rocker cover gasket may be reused if it is not damaged.</p>	<p>Rubber Parts</p>  <p>1EN0023</p>	<p>Do not stain timing belt and V-belt with oil or water. Therefore, do not cleaning the pulley and sprocket with detergent.</p>
<p>Oil and Grease</p>  <p>1EN0024</p>	<p>Before reassembly, apply specified oil to the rotating and sliding parts.</p>	<p>Genuine Part</p>  <p>1EN0025</p>	<p>When the part is replace, be sure to use Mitsubishi genuine part. For selection of appropriate part, refer to the Parts Catalog.</p>

NOTES

4. TIGHTENING TORQUE

General tightening torque is as shown in the following table.
The specific part tightening torque is shown at the beginning of each group.

STANDARD PARTS TIGHTENING TORQUE

TIGHTENING TORQUE OF BOLT OR NUT WITH SPRING WASHER

Classification		Head mark 4			Head mark 7			Head mark 10		
Thread Size mm (dia. x pitch)	Torque	Nm	Kgm	ft.lbs.	Nm	Kgm	ft.lbs.	Nm	Kgm	ft.lbs.
		5 x 0.8	–	–	–	5.0	0.5	4	–	–
6 x 1.0	–	–	–	9.0	0.9	7	13	1.3	9	
8 x 1.25	11	1.1	8	18	1.8	13	30	3.0	22	
10 x 1.25	20	2.0	14	34	3.4	25	60	6.0	43	
12 x 1.25	36	3.6	26	62	6.2	45	108	10.8	78	
14 x 1.5	55	5.5	40	92	9.2	67	175	17.5	127	

TIGHTENING TORQUE OF FLANGE BOLT OR NUT

Classification		Head mark 4			Head mark 7		
Thread Size mm (dia. x pitch)	Torque	Nm	Kgm	ft.lbs.	Nm	Kgm	ft.lbs.
		5 x 0.8	–	–	–	6.0	0.6
6 x 1.0	–	–	–	11	1.1	8	
8 x 1.25	14	1.4	10	24	2.4	17	
10 x 1.25	30	3.0	22	50	5.0	36	
12 x 1.25	55	5.5	40	90	9.0	65	
14 x 1.5	–	–	–	–	–	–	

TIGHTENING TORQUE OF TAPER THREAD

Classification		Aluminium alloy			Cast iron or steel		
Thread Size	Torque	Nm	Kgm	ft.lbs.	Nm	Kgm	ft.lbs.
		1/16	5.0 – 8.0	0.5 – 0.8	4 – 6	8.0 – 12	0.8 – 1.2
1/8	8.0 – 12	0.8 – 1.2	6 – 9	15 – 22	1.5 – 2.2	11 – 16	
1/4	20 – 30	2.0 – 3.0	14 – 22	35 – 45	3.5 – 4.5	25 – 33	
3/8	40 – 55	4.0 – 5.5	29 – 40	55 – 75	5.5 – 7.5	40 – 54	
1/2	70 – 100	7.0 – 10.0	51 – 72	120 – 160	12.0 – 16.0	87 – 116	
3/4	140 – 190	14.0 – 19.0	101 – 137	230 – 280	23.0 – 28.0	166 – 203	

NOTES