

# AIR BAG RESTRAINT SYSTEM

1998 Mitsubishi Galant

1998 AIR BAG RESTRAINT SYSTEMS  
Mitsubishi

Galant

## DESCRIPTION & OPERATION

**WARNING:** To avoid injury from accidental air bag deployment, read and carefully follow all WARNINGS and SERVICE PRECAUTIONS.

Supplemental Restraint System (SRS) consists of an SRS warning light, driver-side and passenger-side air bag module, clockspring, and SRS Air Bag Control Unit (ECU). The SRS-ECU contains an analog and a safing impact sensor. See Fig. 1.

Air bags are designed to deploy in a frontal or near frontal impact of moderate to severe force. For air bags to deploy, ignition must be on and safing impact sensor and at least one front impact sensor must activate simultaneously.

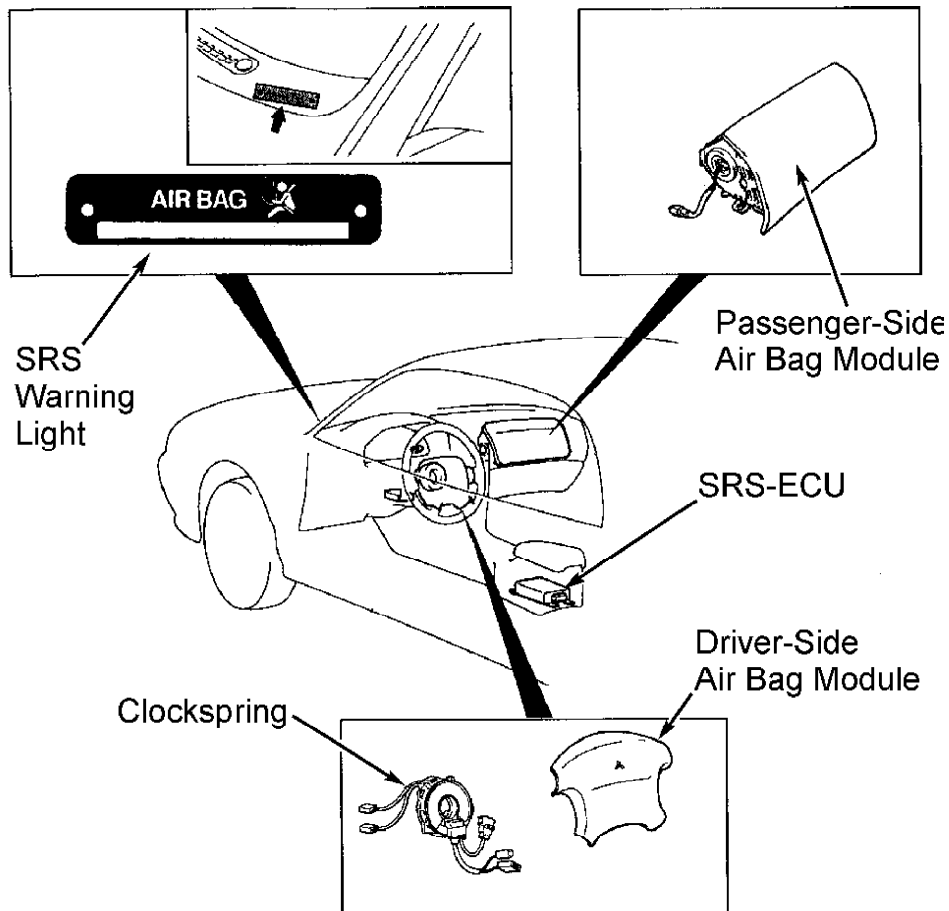

97E05636

Fig. 1: Locating SRS Components  
Courtesy of Mitsubishi Motor Sales of America.

## SRS WARNING LIGHT

When ignition switch is turned to ON or START position, SRS warning light on instrument panel should come on for about 7 seconds and then go off. This indicates SRS-ECU has determined SRS is functioning properly. If SRS warning light flashes, stays on all the time, or does not come on, a fault exists in SRS. See DIAGNOSIS & TESTING.

## **AIR BAG MODULE(S)**

An inflator assembly in the air bag module produces nitrogen gas to fill air bag. See Fig. 1. When a small amount of current from SRS-ECU is applied, ignitor starts a thermal reaction, which spreads to a pellet-filled canister that produces nitrogen gas. Gas pressure builds and discharges from inflator through a diffuser and screen assembly, forcing trim cover to burst along its seams until air bag is fully inflated. When air bag is fully inflated, gas escapes through vents on sides of air bag.

## **SRS AIR BAG CONTROL UNIT (ECU)**

SRS-ECU (with integral safing and analog impact sensor) is located under center floor console assembly. See Fig. 1. If a system fault occurs, SRS-ECU memory stores a code.

## **DATA LINK CONNECTOR (DLC)**

DLC is located under left side of dash. See Fig. 1. DLC is used to access SRS self-diagnostics through Mitsubishi Multi-Use Tester II (MUT-II) (MB991502).

## **CLOCKSPRING**

Clockspring connects driver-side air bag module to steering column wiring, forming SRS circuit. See Fig. 1. Clockspring is a flat, ribbon-like cable that winds and unwinds when steering wheel is turned. Because of clockspring's constant movement, it is the most fragile part in the system.

## **SYSTEM OPERATION CHECK**

**WARNING:** After servicing, always turn ignition on from passenger-side of vehicle in case of accidental air bag deployment.

Turn ignition switch to ON position. SRS warning light on instrument panel should come on for about 7 seconds and then turn off. This indicates SRS is functioning properly. If SRS warning light does not come on, stays on, or comes on while driving, SRS is malfunctioning and needs repair. See DIAGNOSIS & TESTING.

## **SERVICE PRECAUTIONS**

Observe the following precautions when working with SRS:

- \* Disable SRS before servicing any SRS or steering column component. Failure to do this may result in accidental air bag deployment and possible personal injury. Refer to DISABLING & ACTIVATING AIR BAG SYSTEM.
- \* For about 60 seconds after air bag system is disabled, it retains enough voltage to deploy air bags. After disabling system, wait at least 60 seconds before servicing.
- \* After servicing, always turn ignition on from passenger-side

- of vehicle in case of accidental air bag deployment.
- \* After servicing, check SRS warning light to verify system operation. See SYSTEM OPERATION CHECK.
  - \* Always wear safety glasses when servicing or handling an air bag.
  - \* The SRS-ECU must be stored in its original special container until used for service. It must be stored in a clean, dry place, away from sources of extreme heat, sparks and high electrical energy.
  - \* DO NOT expose air bag module and clockspring to temperatures greater than 200°F (93°C).
  - \* When placing a live air bag module on a bench or other surface, always face air bag module and trim cover up, away from surface. This will reduce motion of module if air bag accidentally deploys.
  - \* After air bag deploys, air bag surface may contain deposits of sodium hydroxide, which irritates skin. Always wear safety glasses, rubber gloves and long-sleeved shirt during clean-up. Wash hands using mild soap and water. Follow correct clean-up and disposal procedures. Refer to DISPOSAL PROCEDURES.
  - \* Because of critical system operating requirements, DO NOT service any SRS components. Repairs are only made by replacing defective part(s).
  - \* DO NOT allow any electrical source near inflator on the back of air bag module.
  - \* When carrying a live (undeployed) air bag module, trim cover must be pointed away from body to minimize injury in case of accidental air bag deployment.
  - \* DO NOT probe wire harness connector terminals. Instead, use SRS Check Harness (MB991530).
  - \* DO NOT probe a wire through insulator, as this will damage it and eventually cause failure due to corrosion.
  - \* When performing electrical tests, prevent accidental shorting of terminals. Such shorts can damage fuses or components and may cause a second fault code to set, making diagnosis of original problem more difficult.
  - \* Never use an analog volt/ohmmeter or test light in place of a Digital Volt/ohmmeter (DVOM). Use only a DVOM with a maximum test current of 2 mA (milliamps) at minimum range of resistance measurement. Also see SPECIAL TOOLS.
  - \* If SRS is not fully functional for any reason, DO NOT drive vehicle until system is repaired and is fully functional. DO NOT remove bulbs, modules, sensors or other components, or in any way disable system from operating normally. If SRS is not functional, park vehicle until repairs are made.

## SPECIAL TOOLS

To avoid air bag deployment when working on SRS, DO NOT use electrical test equipment such as test lights, battery or A/C-powered volt/ohmmeter, or any type of electrical equipment other than those specified by manufacturer. See SRS RECOMMENDED TOOLS table.

### SRS RECOMMENDED TOOLS

Tool Name	Tool Number
For Component Replacement	
Steering Wheel Puller .....	MB990803
For Testing SRS	
Digital Volt/Ohmmeter (DVOM) .....	(1)
Multi-Use Tester II .....	MB991502

ROM Pack ..... (2)  
 SRS Check Harness ..... MB991613  
 For Deploying Air Bags  
 SRS Air Bag Adapter Harness "A" (3) ..... MB686560  
 SRS Air Bag Adapter Harness "B" (4) ..... MB628919

- (1) - Maximum current output of DVOM must not exceed 2 mA (milliamps) when set on minimum range of resistance measurement.
  - (2) - ROM pack is used with multi-use tester.
  - (3) - For on-vehicle deployment of driver-side air bag. For on-vehicle or off-vehicle deployment of passenger-side air bag.
  - (4) - For off-vehicle deployment of driver-side air bag.
- 

## DISABLING & ACTIVATING AIR BAG SYSTEM

**WARNING:** SRS system voltage is maintained for about 60 seconds after battery cable is disconnected. After disconnecting battery cable, wait at least 60 seconds before servicing SRS. Failure to wait may cause accidental air bag deployment and possible personal injury.

To disable system, turn ignition switch to LOCK position. Disconnect negative battery cable. Shield cable end. Wait at least 60 seconds before servicing. To activate system, reconnect negative battery cable.

## DISPOSAL PROCEDURES

**WARNING:** Undeployed air bag must be deployed before disposal. Disposing of an undeployed air bag may violate federal, state and/or local laws. This also applies to vehicles that are to be scrapped. Never sell a used air bag module.

## UNDEPLOYED AIR BAG

**WARNING:** Deploy air bag outdoors and away from people. Air bag deployment makes a loud noise. NEVER deploy air bag module with trim cover face down.

**NOTE:** If replacing a deployed air bag, both front impact sensors and SRS-ECU must also be replaced. If vehicle is to be scrapped, perform PROCEDURE 1 (ON-VEHICLE DEPLOYMENT) below. If vehicle will continue to be operated, perform PROCEDURE 2 (OFF-VEHICLE DEPLOYMENT) below.

### Procedure 1 (On-Vehicle Deployment)

1) Before proceeding, follow air bag service precautions. See SERVICE PRECAUTIONS. Open all doors and windows. Move vehicle to an isolated area. Disconnect negative battery cable and wrap tape around cable terminal.

2) Disconnect positive battery cable. Remove battery. Wait at least 60 seconds before continuing. Remove steering column lower cover. Disconnect clockspring 2-pin Red connector.

3) Make a harness with two 20-foot (or longer) wires. Connect wires at one end of this harness to SRS Air Bag Adapter Harness "A" (MB686560). Wrap connections with insulating tape. See Fig. 2.

4) Temporarily connect other end of harness wires together to prevent unexpected air bag deployment. Connect SRS air bag adapter

harness "A" to clockspring 2-pin Red connector. Run 20-foot wires outside of vehicle as far away as possible from vehicle.

5) Ensure there are no loose parts in passenger compartment and no one is within 20 feet of vehicle.

6) Deploy air bag by connecting ends of 20-foot wires to terminals of a 12-volt battery. If air bags fail to deploy, go to PROCEDURE 2 below. After deployment, allow air bag modules to cool and dust to settle for at least 30 minutes before approaching vehicle.

### Driver-Side Air Bag Adapter Harness

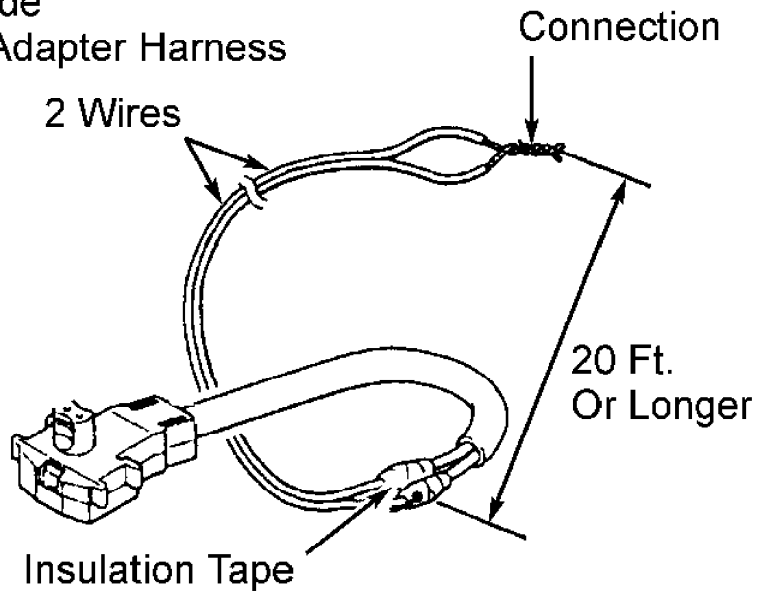

### Passenger-Side Air Bag Adapter Harness

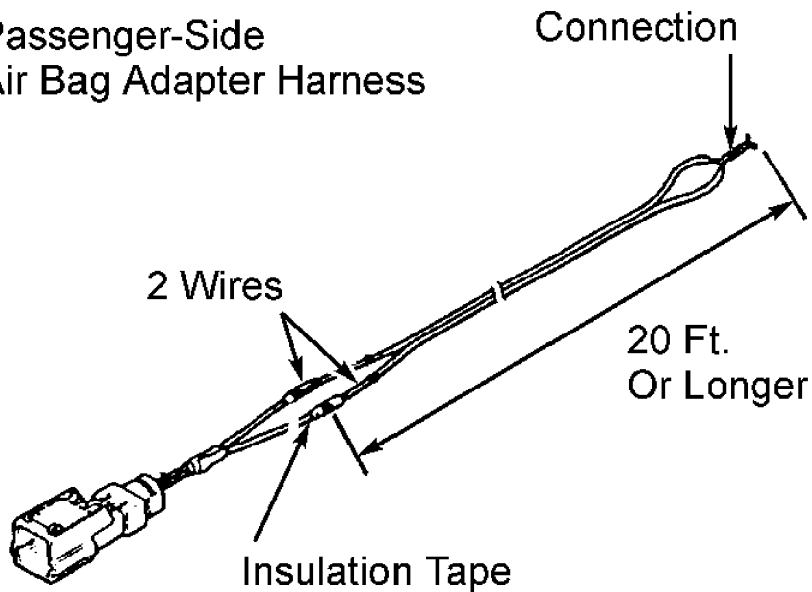

96A05639

Fig. 2: Connecting Wires To Air Bag Adapter Harness  
Courtesy of Mitsubishi Motor Sales of America.

Procedure 2 (Off-Vehicle Deployment)

1) Before proceeding, follow air bag service precautions. See

SERVICE PRECAUTIONS. Turn ignition switch to LOCK position. Disconnect negative battery cable. Shield cable end. Disconnect positive battery cable. Remove battery. Wait at least 60 seconds before continuing.

2) Remove air bag module. Place air bag module on ground at least 20 feet away from people or objects. Air bag module face (trim cover) must face upward to prevent movement of air bag module when it is deployed.

3) Make a harness with two 20-foot (or longer) wires. Connect wires at one end of this harness to stripped wires of SRS Air Bag Adapter Harness "B" (MB628919) for driver-side air bag, or SRS Air Bag Adapter Harness "A" (MB686560) for passenger-side air bag. See Fig. 2.

4) Wrap connections with insulating tape. Temporarily connect other end of harness wires together to prevent unexpected air bag deployment. Connect appropriate adapter harness to air bag module connector. Place a tire without a rim over the air bag module so rim hole surrounds air bag module. Stack 3 more tires on top of first tire. Connect ends of 20-foot wires to terminals of a 12-volt battery.

5) After air bag module deploys, let it cool off and allow dust to settle for at least 30 minutes before approaching. Tightly seal deployed air bag module in a strong vinyl bag and dispose of air bag as you would any other part.

## DEPLOYED AIR BAG CLEAN-UP

**WARNING:** Vehicle interior will contain sodium hydroxide powder, a by-product of air bag deployment. Since this powder can irritate skin, eyes, nose and throat, wear safety glasses, rubber gloves and long-sleeved shirt during clean-up.

1) Avoid breathing powder from air bag deployment. Begin clean-up by putting tape over air bag exhaust vent to prevent additional powder from escaping into vehicle interior. Use a vacuum cleaner to remove any residual powder from A/C-heater outlets and vehicle interior.

2) Turn blower motor to low for a few minutes and exit vehicle. Turn blower motor off. Vacuum any other powder expelled from plenum. Vacuum interior a second time to recover all powder. Avoid kneeling or sitting on unclean areas. Wrap deployed air bag in heavy vinyl plastic and dispose of it as you would any other part.

## POST-COLLISION INSPECTION

When a vehicle has been involved in a collision, certain components of the passive restraint system must be inspected or replaced. See PASSIVE RESTRAINT SYSTEM INSPECTION article in the GENERAL INFORMATION section for post-collision inspection information.

## REMOVAL & INSTALLATION

**WARNING:** Follow air bag service precautions to prevent accidental air bag deployment and personal injury. See SERVICE PRECAUTIONS. Replace faulty SRS components; DO NOT repair or disassemble. Handle all SRS components carefully.

## DRIVER-SIDE AIR BAG MODULE & CLOCKSPRING

**NOTE:** If replacing deployed air bag module, SRS-ECU must be replaced.

Removal

1) Before proceeding, see SERVICE PRECAUTIONS. Deactivate

SRS. See DISABLING & ACTIVATING AIR BAG SYSTEM.

2) Ensure front wheels are in straight-ahead position and steering wheel is locked. Remove lower covers from air bag module. Remove air bag module mounting nut using a socket wrench from back side. See Fig. 3. Remove air bag module mounting screws. Lift air bag module for access to clockspring connector at air bag module. To disconnect clockspring connector from air bag module, spread connector open and pry it outward with a screwdriver. Remove air bag module. See Fig. 4.

3) Place air bag module on flat surface with trim cover facing up. Remove steering wheel with Steering Wheel Puller (MB990803). Remove lower column cover. Disconnect clockspring lower connectors. Remove clockspring mounting screws. Remove clockspring.

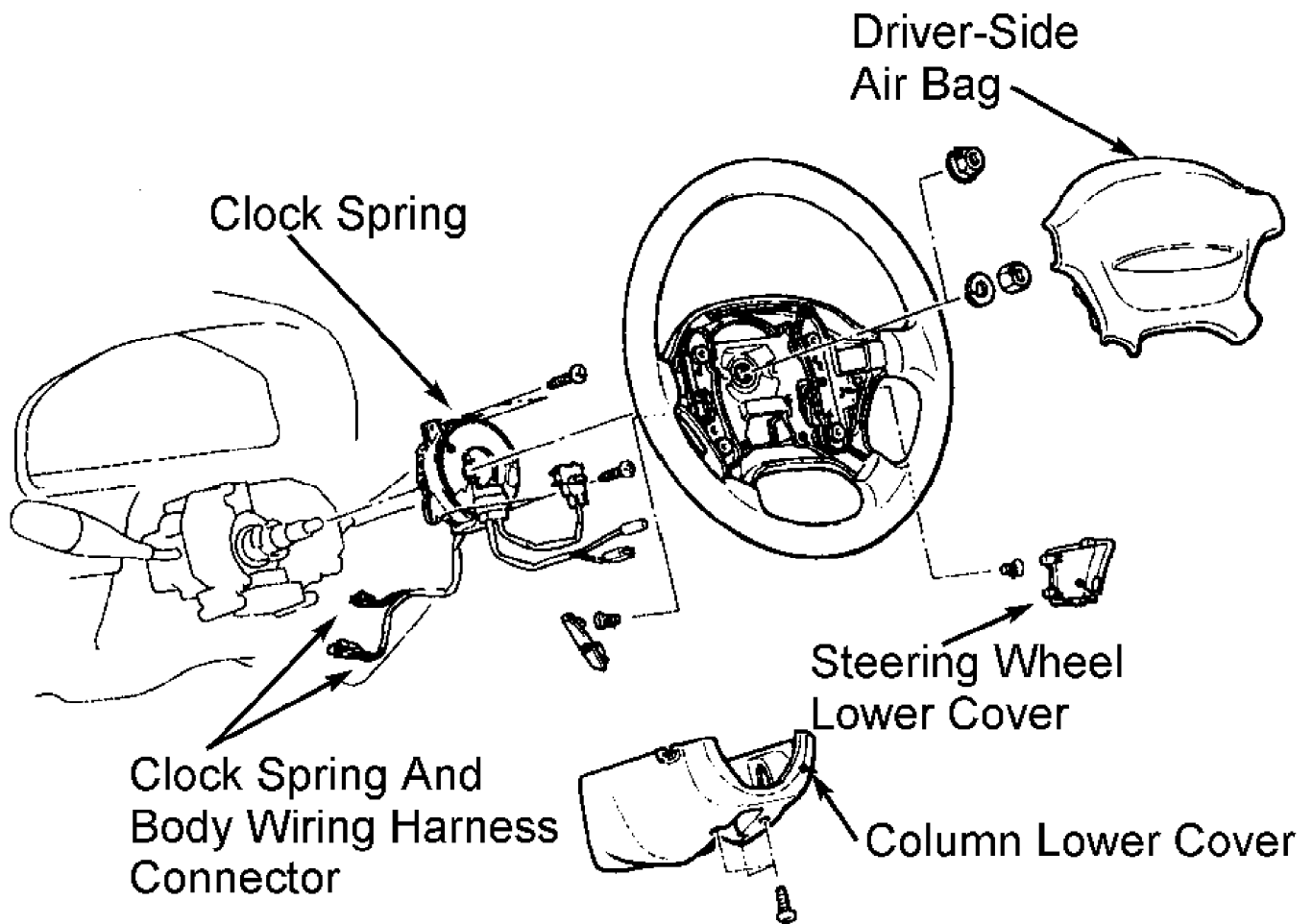

**96C05640**

Fig. 3: Removing & Installing Driver-Side Air Bag & Clockspring  
Courtesy of Mitsubishi Motor Sales of America.

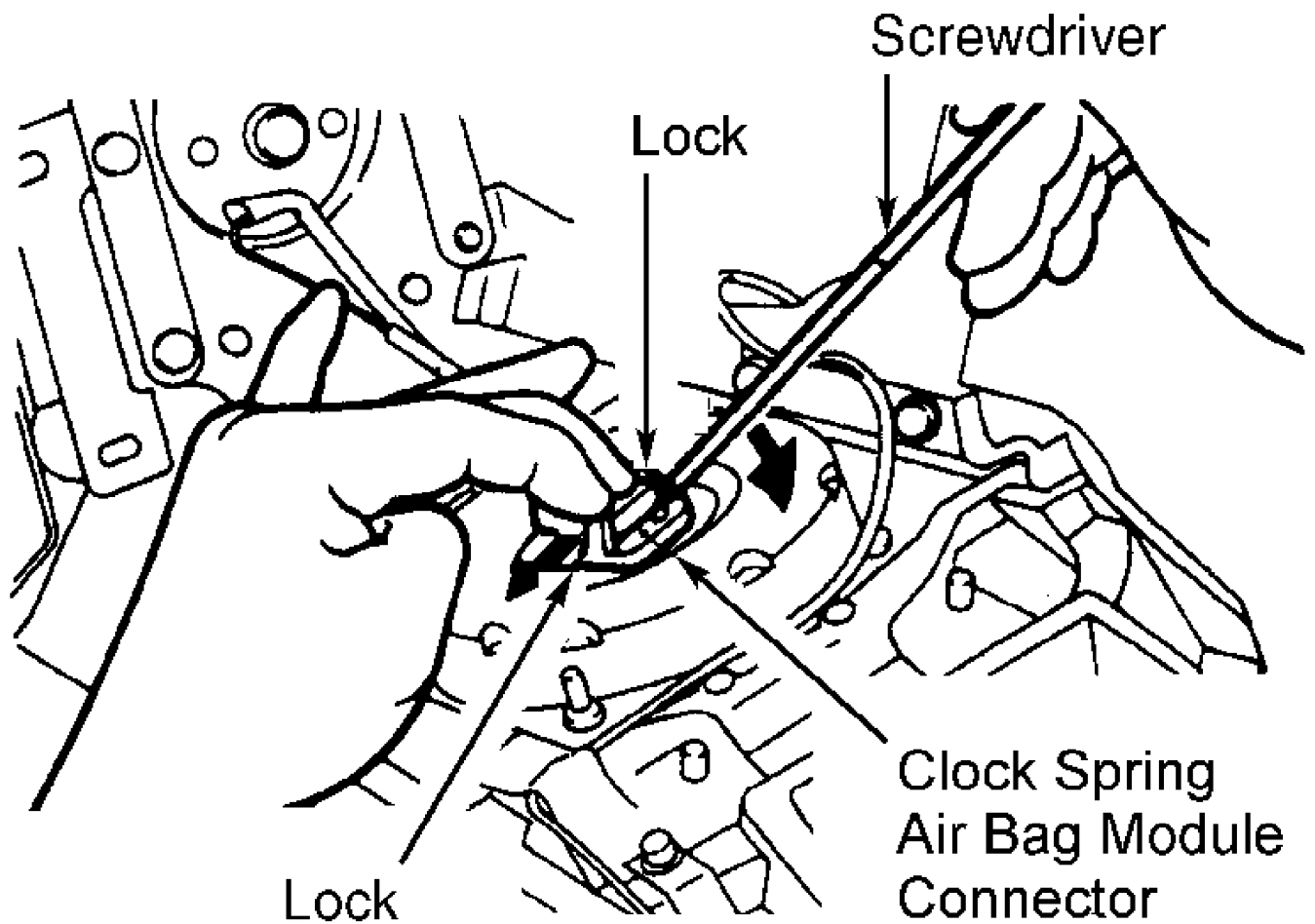

96G05642

Fig. 4: Disconnecting Clockspring Connector From Air Bag Module  
 Courtesy of Mitsubishi Motor Sales of America.

**WARNING:** If front wheels are not in straight-ahead position or clockspring mating marks are not aligned before installing clockspring, the steering wheel may not turn completely, or flat cable inside clockspring may be severed, disabling SRS system and possibly causing serious injury to driver.

Installation

1) Ensure front wheels are in straight-ahead position. On clockspring, align mating marks. See Fig. 5. Install clockspring. To install remaining components, reverse removal procedure. Before installing air bag module, ensure horn switch wiring is positioned so that it will not be pinched.

2) Tighten fasteners to specification. See TORQUE SPECIFICATIONS. Activate SRS. See DISABLING & ACTIVATING AIR BAG SYSTEM. Check AIR BAG warning light for proper system function. See SYSTEM OPERATION CHECK.



## Mating Marks

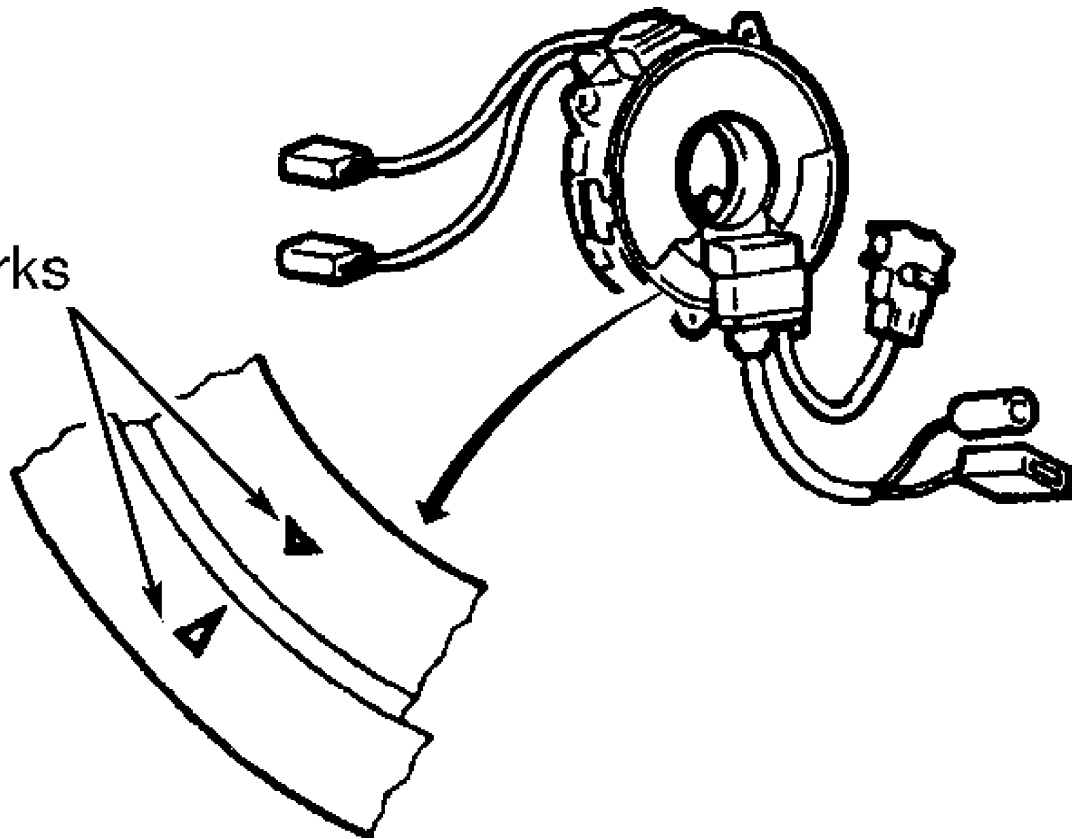

96E05641

Fig. 5: Aligning Clockspring Mating Marks  
Courtesy of Mitsubishi Motor Sales of America.

### PASSENGER-SIDE AIR BAG MODULE

**NOTE:** If replacing deployed air bag module, SRS-ECU must be replaced.

#### Removal & Installation

1) Before proceeding, see SERVICE PRECAUTIONS. Deactivate SRS. See DISABLING & ACTIVATING AIR BAG SYSTEM.

2) Remove glove box and cover. Disconnect air bag module connector. Remove air bag module retaining bolts. Remove passenger-side air bag module. See Fig. 6.

3) To install, reverse removal procedure. Tighten bolts to specification. See TORQUE SPECIFICATIONS. Activate SRS. See procedures under DISABLING & ACTIVATING AIR BAG SYSTEM. Check AIR BAG warning light for proper system function. See SYSTEM OPERATION CHECK.

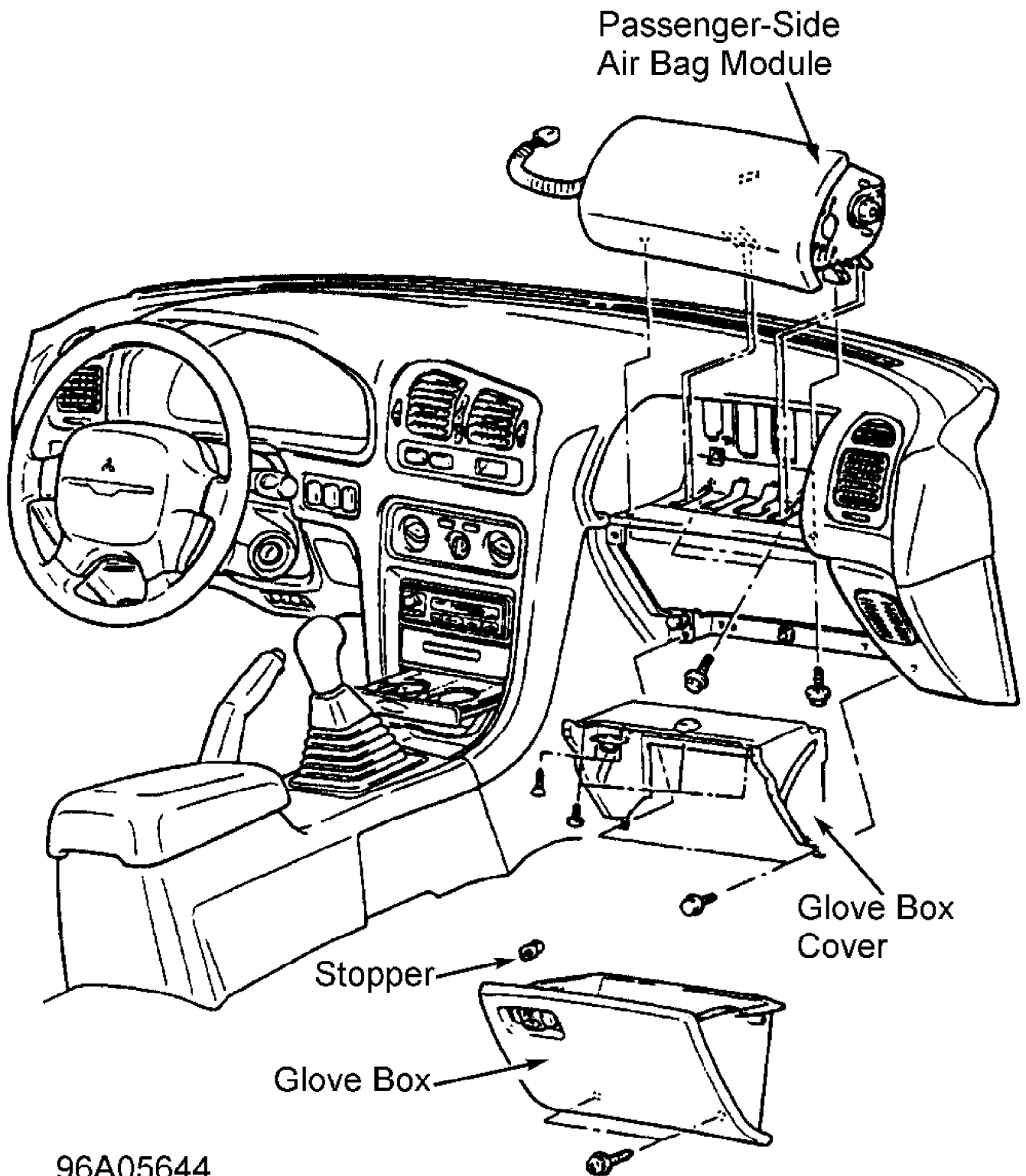

96A05644

Fig. 6: Removing Passenger-Side Air Bag Module  
Courtesy of Mitsubishi Motor Sales of America.

SRS AIR BAG CONTROL UNIT (ECU)

#### Removal & Installation

1) Before proceeding, see SERVICE PRECAUTIONS. Deactivate SRS. See DISABLING & ACTIVATING AIR BAG SYSTEM.

2) Remove center console floor assembly. See Fig. 7. Disconnect SRS-ECU connector. Remove SRS-ECU mounting bolts. Remove SRS-ECU.

3) To install, reverse removal procedure. Tighten bolts to specification. See TORQUE SPECIFICATIONS. Activate SRS. See procedures under DISABLING & ACTIVATING AIR BAG SYSTEM. Check AIR BAG warning light for proper system function. See SYSTEM OPERATION CHECK.

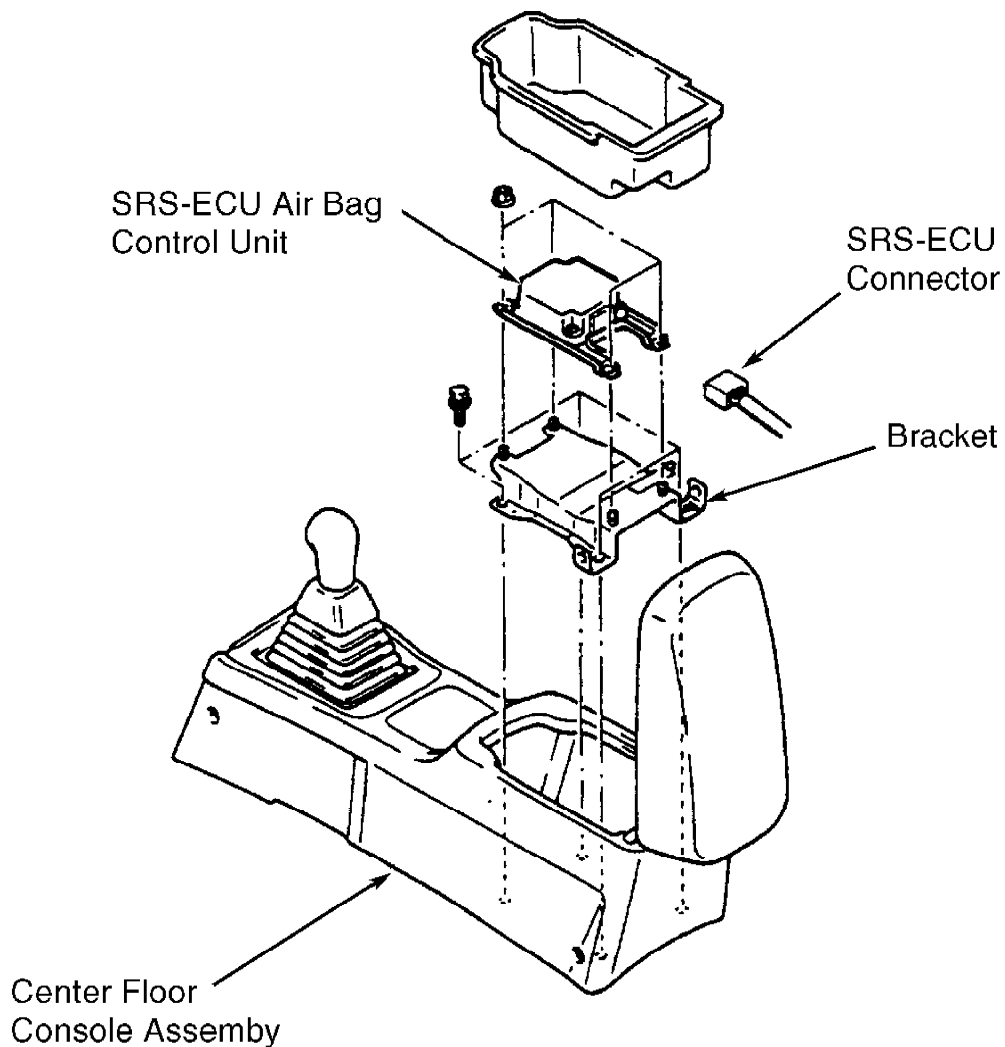

98A13433

Fig. 7: Removing SRS Air Bag Control Unit (ECU)  
Courtesy of Mitsubishi Motor Sales of America.

## ADJUSTMENTS

## CLOCKSPRING CENTERING

**WARNING:** If front wheels are not in straight-ahead position or clockspring mating marks are not aligned before installing clockspring, the steering wheel may not turn completely, or flat cable inside clockspring may be severed, disabling SRS system and possibly causing serious injury to driver.

With clockspring removed, ensure front wheels are in straight-ahead position. Turn clockspring fully clockwise, and then turn it back approximately 3 1/3 turns counterclockwise to align mating marks. See Fig. 5.

## WIRE REPAIR

DO NOT repair SRS wiring or harness connectors. If SRS wiring or harness connectors are faulty, replace faulty wiring harness.

## TORQUE SPECIFICATIONS

### TORQUE SPECIFICATIONS

Application	Ft. Lbs. (N.m)
Steering Wheel Nut .....	30 (41)
	INCH Lbs. (N.m)
Air Bag Module Bolt/Nut	
Driver-Side .....	84 (9.0)
Passenger-Side .....	(1)
Clockspring Screw .....	(1)
SRS-ECU (Air Bag Control Unit) Bolt .....	(1)

(1) - Information is not available from manufacturer.

## DIAGNOSIS & TESTING

### INITIAL SRS DIAGNOSTIC PROCEDURE

**WARNING:** Follow air bag service precautions to prevent accidental air bag deployment and personal injury. See SERVICE PRECAUTIONS.

**NOTE:** Ensure battery is fully charged. If battery voltage is too low, SRS warning light will come on. When battery voltage is restored to normal, light will go out. Codes remain stored for no more than about 7 days. Codes can be stored no more than 250 times. After servicing, reconnect negative battery cable. Erase codes using Multi-Use Tester II (MUT-II, MB991502) or DRB-III Scan Tool. Check SRS warning light to verify system operation. See SYSTEM OPERATION CHECK.

**CAUTION:** Ensure ignition is off before connecting or disconnecting scan tool at DLC.

1) Before proceeding, follow service precautions. See SERVICE PRECAUTIONS. Turn ignition on. If SRS warning light comes on for about 7 seconds and turns off, SRS is functioning properly at this

time.

2) If SRS warning light does not come on, or comes on and stays on, turn ignition switch to LOCK position. Connect scan tool to Data Link Connector (DLC). See Fig. 8. Turn ignition on. Use scan tool to retrieve code(s).

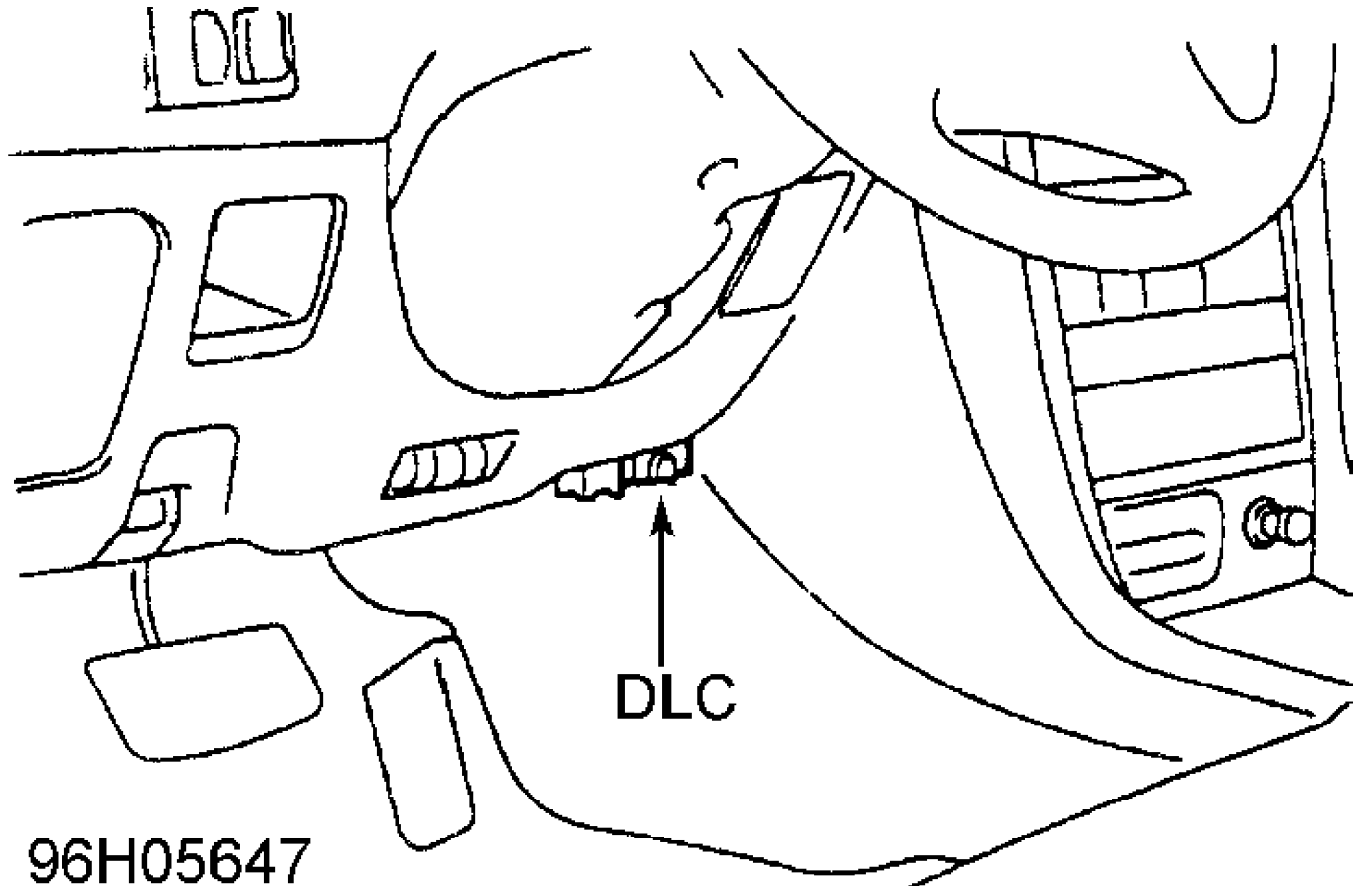

Fig. 8: Locating Data Link Connector (DLC)  
Courtesy of Mitsubishi Motor Sales of America.

TROUBLE SYMPTOMS CHART

Symptom	Inspection Procedure
Communication With All Systems Not Possible	1
Communication With SRS Only Not Possible	2
Ignition Switch On (Engine Stopped)	
SRS Warning Light Does Not Come On	DTC 43
SRS Warning Light Stays On After 7 Seconds	DTC 43

INSPECTION PROCEDURE 1

The cause is probably in power supply system (including ground circuit of diagnostic line). Check connectors and harness, and repair if necessary.

INSPECTION PROCEDURE 2

NOTE: Refer to WIRING DIAGRAMS for connector identification.

1) Before proceeding, see SERVICE PRECAUTIONS. Deactivate SRS. See DISABLING & ACTIVATING AIR BAG SYSTEM.

2) Measure at SRS Check Harness (MB991613) connector No. 5. See Fig. 9. Remove center console floor assembly to access SRS-ECU. See Fig. 7. Disconnect SRS-ECU connector C-14. Connect SRS check harness connector No. 3 to C-14. Check continuity between terminal No. 20, 21 and ground. If there is no continuity, go to next step. If there is continuity, go to step 4).

3) Check connector C-14 and repair if necessary. If connector is okay, check for trouble symptoms. If fault still exists, check harness wire between SRS-ECU and ground, and repair if necessary.

4) Measure at SRS check harness connector No. 5. Disconnect SRS-ECU connector C-14 and connect SRS harness check connector No. 3 to C-14. Connect negative battery cable and turn ignition switch to ON position. Measure voltage between terminal No. 13 and 14, and body ground. If voltage at terminals is 9 volts or more, replace SRS-ECU. See SRS AIR BAG CONTROL UNIT (ECU) under REMOVAL & INSTALLATION. If voltage is not as specified, check connector D-14, C-37, C-35, C-53, and C-45, and repair if necessary. If connectors are okay, check for trouble symptoms. If fault still exists, check harness wire between SRS-ECU and ignition switch IG1, and repair if necessary.

## SRS Check Harness (MB991613)

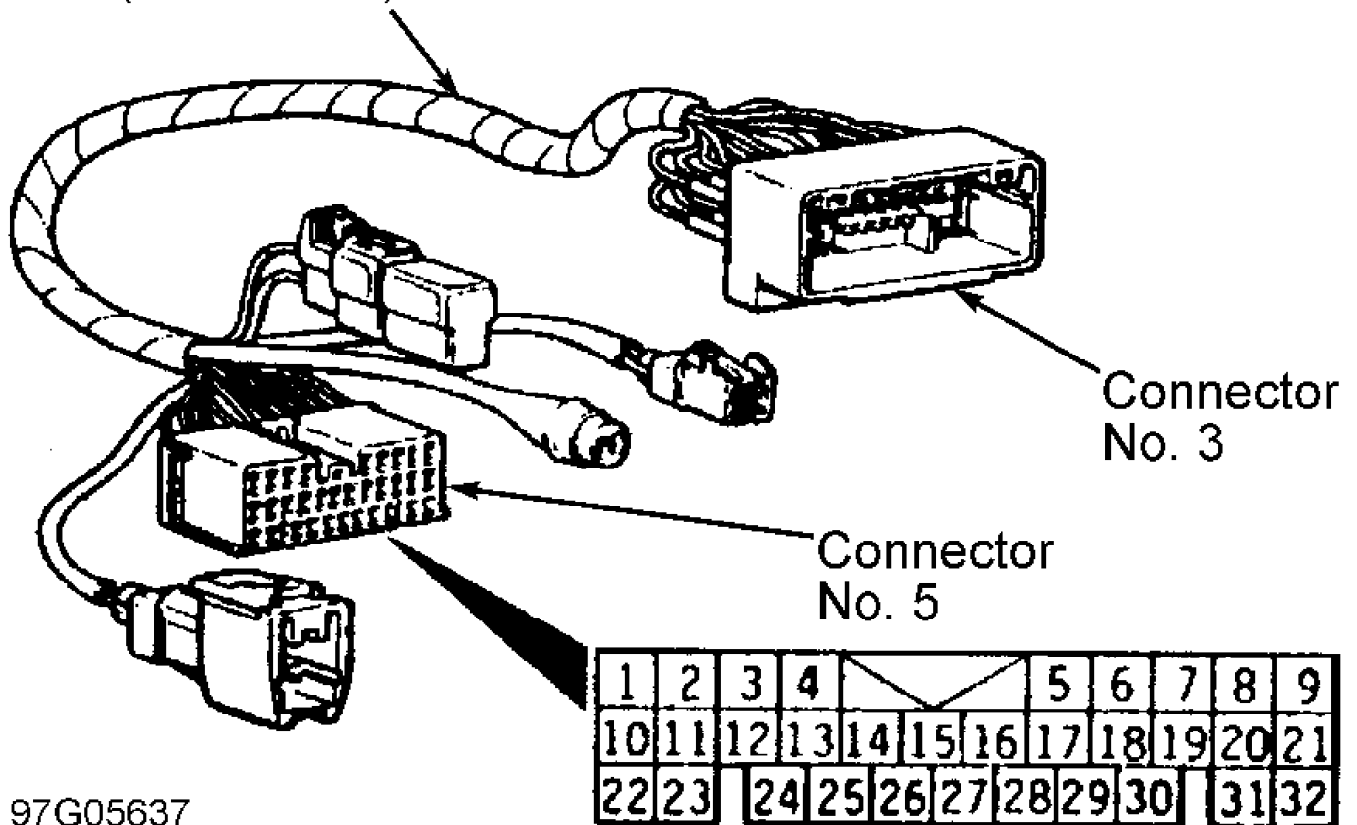

97G05637

Fig. 9: Identifying SRS Check Harness (MB991613) Connectors  
Courtesy of Mitsubishi Motor Sales of America.

### DTC 14: ANALOG IMPACT SENSOR

Before proceeding, see SERVICE PRECAUTIONS. Replace SRS-ECU.

See SRS AIR BAG CONTROL UNIT (ECU) under REMOVAL & INSTALLATION.

### **DTC 15 & 16: SAFING IMPACT SENSOR**

Before proceeding, see SERVICE PRECAUTIONS. Replace SRS-ECU. See SRS AIR BAG CONTROL UNIT (ECU) under REMOVAL & INSTALLATION.

### **DTC 21, 22, 61, 62: DRIVER-SIDE AIR BAG MODULE SYSTEM**

**WARNING:** During the following procedure, never measure circuit resistance of air bag module (squib), even when using specified DVOM. If circuit resistance is measured, it may cause accidental air bag deployment and personal injury.

**NOTE:** Refer to WIRING DIAGRAMS for connector identification.

- 1) Before proceeding, see SERVICE PRECAUTIONS. Deactivate SRS. See DISABLING & ACTIVATING AIR BAG SYSTEM.
- 2) Disconnect clockspring connector C-05. Connect SRS Check Harness (MB991613) connector No. 1 to clockspring connector. See Fig. 9. Connect negative battery cable. Erase DTC memory and check if DTCs 21, 22, 61, or 62 are set. If any of these DTCs are output, go to next step. If DTCs are not output, go to step 4).
- 3) Check connectors C-05 and C-14, and repair if necessary. If connectors are okay, check trouble symptoms. If fault is still present, check harness wire between SRS-ECU and clockspring, and repair if necessary. If harness wire is okay, replace SRS-ECU. See SRS AIR BAG CONTROL UNIT (ECU) under REMOVAL & INSTALLATION.
- 4) Check clockspring and replace if necessary. See DRIVER-SIDE AIR BAG MODULE & CLOCKSPrING under REMOVAL & INSTALLATION. If clockspring is okay, replace driver-side air bag module.

### **DTC 24, 25, 64, 65: PASSENGER-SIDE AIR BAG MODULE SYSTEM**

**WARNING:** During the following procedure, never measure circuit resistance of air bag module (squib), even when using specified DVOM. If circuit resistance is measured, it may cause accidental air bag deployment and personal injury.

**NOTE:** Refer to WIRING DIAGRAMS for connector identification.

- 1) Before proceeding, see SERVICE PRECAUTIONS. Deactivate SRS. See DISABLING & ACTIVATING AIR BAG SYSTEM.
- 2) Disconnect passenger-side air bag connector C-10. Connect SRS Check Harness (MB991613) connector No. 1 to passenger-side air bag connector. See Fig. 9. Connect negative battery cable. Erase DTC memory and check if DTCs 24, 25, 64, or 65 are set. If any of these DTCs are output, go to next step. If DTCs are not output, replace passenger-side air bag module. See PASSENGER-SIDE AIR BAG MODULE under REMOVAL & INSTALLATION.
- 3) Check connectors C-10 and C-14, and repair if necessary. If connectors are okay, check trouble symptoms. If fault is still present, check harness wire between passenger-side air bag module and SRS-ECU, and repair if necessary. If harness wire is okay, replace SRS-ECU. See SRS AIR BAG CONTROL UNIT (ECU) under REMOVAL & INSTALLATION.

### **DTC 31 & 32: SRS-ECU CAPACITOR SYSTEM**

Before proceeding, see SERVICE PRECAUTIONS. Replace SRS-ECU. See SRS AIR BAG CONTROL UNIT (ECU) under REMOVAL & INSTALLATION.

## DTC 34: CONNECTOR LOCK SYSTEM

NOTE: If vehicle condition returns to normal, DTC will be erased and SRS warning light will return to normal.

NOTE: Refer to WIRING DIAGRAMS for connector identification.

Before proceeding, see SERVICE PRECAUTIONS. Check connector C-14 and repair if necessary. If connector is okay, replace SRS-ECU. See SRS AIR BAG CONTROL UNIT (ECU) under REMOVAL & INSTALLATION.

## DTC 35: SRS-ECU AIR BAG SYSTEM/AIR BAG DEPLOYMENT

Before proceeding, see SERVICE PRECAUTIONS. Replace SRS-ECU. See SRS AIR BAG CONTROL UNIT (ECU) under REMOVAL & INSTALLATION.

## DTC 41: IG1 (A) POWER CIRCUIT SYSTEM

NOTE: If vehicle condition returns to normal, DTC will be erased and SRS warning light will return to normal.

NOTE: Refer to WIRING DIAGRAMS for connector identification.

1) Before proceeding, see SERVICE PRECAUTIONS. Deactivate SRS. See DISABLING & ACTIVATING AIR BAG SYSTEM.

2) Measure at SRS Check Harness (MB991613) connector No. 5. See Fig. 9. Disconnect SRS-ECU connector C-14 and connect SRS check harness connector No. 3 to C-14. Check terminal No. 20 and 21 for continuity to ground. If there is no continuity, go to next step. If there is continuity, go to step 4).

3) Check connector C-14 and repair if necessary. If connector is okay, check for trouble symptoms. If fault still exists, check harness wire between SRS-ECU and ground, and repair if necessary.

4) Measure at SRS check harness connector No. 5. Disconnect SRS-ECU connector C-14 and connect SRS harness check connector No. 3 to C-14. Connect negative battery cable and turn ignition switch to ON position. If voltage between terminal No. 14 and body ground is 9 volts or more, replace SRS-ECU. See SRS AIR BAG CONTROL UNIT (ECU) under REMOVAL & INSTALLATION. If voltage is not as specified, check connector C-14, C-35, and C-53, and repair if necessary. If connectors are okay, check for trouble symptoms. If fault still exists, check harness wire between SRS-ECU and ignition switch IG1, and repair if necessary.

## DTC 42: IG1 (B) POWER CIRCUIT SYSTEM

NOTE: If vehicle condition returns to normal, DTC will be erased and SRS warning light will return to normal.

NOTE: Refer to WIRING DIAGRAMS for connector identification.

1) Before proceeding, see SERVICE PRECAUTIONS. Deactivate SRS. See DISABLING & ACTIVATING AIR BAG SYSTEM.

2) Measure at SRS Check Harness (MB991613) connector No. 5. See Fig. 9. Disconnect SRS-ECU connector C-14 and connect SRS check harness connector No. 3 to C-14. Check terminal No. 20 and 21 for continuity to ground. If there is no continuity, go to next step. If there is continuity, go to step 4).

3) Check connector C-14 and repair if necessary. If connector is okay, check for trouble symptoms. If fault still exists, check harness wire between SRS-ECU and ground, and repair if necessary.

4) Measure at SRS check harness connector No. 5. Disconnect



SRS-ECU connector C-14 and connect SRS harness check connector No. 3 to C-14. Connect negative battery cable and turn ignition switch to ON position. If voltage between terminal No. 13 and body ground is 9 volts or more, replace SRS-ECU. See SRS AIR BAG CONTROL UNIT (ECU) under REMOVAL & INSTALLATION. If voltage is not as specified, check connector D-14, C-37, and C-45, and repair if necessary. If connectors are okay, check for trouble symptoms. If fault still exists, check harness wire between SRS-ECU and ignition switch IGL, and repair if necessary.

### DTC 43: SRS WARNING LIGHT DOES NOT COME ON

NOTE: Refer to WIRING DIAGRAMS for connector identification.

#### Light Does Not Come On

1) Before proceeding, see SERVICE PRECAUTIONS. Deactivate SRS. See DISABLING & ACTIVATING AIR BAG SYSTEM.

2) Measure at SRS Check Harness (MB991613) connector No. 5. See Fig. 9. Disconnect SRS-ECU connector C-14 and connect SRS check harness connector No. 3 to C-14. Check terminal No. 20 and 21 for continuity to ground. If there is no continuity, go to next step. If there is continuity, go to step 4).

3) Check connector C-14 and repair if necessary. If connector is okay, check for trouble symptoms. If fault still exists, check harness wire between SRS-ECU and ground, and repair if necessary.

4) Measure at SRS check harness connector No. 5. Disconnect SRS-ECU connector C-14 and connect SRS harness check connector No. 3 to C-14. Connect negative battery cable and turn ignition switch to ON position. Connect terminal No. 15 to body ground. If SRS warning light comes on, replace SRS-ECU. See SRS AIR BAG CONTROL UNIT (ECU) under REMOVAL & INSTALLATION. If SRS warning light does not come on, inspect for blown bulb and repair if necessary. If bulb is okay, check connector C-14, C-37, C-45, D-02, D-03, and D-14, and repair if necessary. If connectors are okay, check for trouble symptoms. If fault still exists, check harness wire between SRS-ECU and ignition switch IGL, and repair if necessary. If harness wire is okay, replace combination meter.

#### Light Does Not Turn Off

1) Before proceeding, see SERVICE PRECAUTIONS. Connect negative battery cable and turn ignition switch to ON position. If SRS warning light stays on when C-14 is disconnected, go to next step. If SRS warning light turns off when C-14 is disconnected, replace SRS-ECU. See SRS AIR BAG CONTROL UNIT (ECU) under REMOVAL & INSTALLATION.

2) Check connector C-14, D-03, and D-14, and repair if necessary. If connectors are okay, check trouble symptoms. If fault still exists, check wire harness between SRS-ECU and combination meter, and repair if necessary.

### DTC 44: SRS WARNING LIGHT DRIVE CIRCUIT SYSTEM

NOTE: If vehicle condition returns to normal, DTC will be erased and SRS warning light will return to normal.

Before proceeding, see SERVICE PRECAUTIONS. Check SRS warning light drive circuit system. If warning light drive system is okay, replace SRS-ECU. See SRS AIR BAG CONTROL UNIT (ECU) under REMOVAL & INSTALLATION.

### DTC 45: SRS-ECU EEPROM AND A/D CONVERTER SYSTEM

Before proceeding, see SERVICE PRECAUTIONS. Replace SRS-ECU. See SRS AIR BAG CONTROL UNIT (ECU) under REMOVAL & INSTALLATION.

## DTC 51 & 52: SRS-ECU EEPROM AND A/D CONVERTER SYSTEM

Before proceeding, see SERVICE PRECAUTIONS. Replace SRS-ECU. See SRS AIR BAG CONTROL UNIT (ECU) under REMOVAL & INSTALLATION.

## DTC 54 & 55: PASSENGER-SIDE AIR BAG MODULE IGNITION DRIVE CIRCUIT

Before proceeding, see SERVICE PRECAUTIONS. Replace SRS-ECU. See SRS AIR BAG CONTROL UNIT (ECU) under REMOVAL & INSTALLATION.

## COMPONENT TESTING

### CLOCKSPRING TEST

1) Before proceeding, see SERVICE PRECAUTIONS. Deactivate system. See DISABLING & ACTIVATING AIR BAG SYSTEM.

2) Remove driver-side air bag module and clockspring. See DRIVER-SIDE AIR BAG MODULE & CLOCKSPRING under REMOVAL & INSTALLATION. Check connectors, protective tubing, and case for damage, and terminals for deformities. Check for continuity between No. 1 connector of clockspring and connectors No. 3 and 4. See Figs. 10 and 11.

3) Align paint mark of SRS Check Harness (MB991613) connector No. 4 with notch in clockspring connector No. 2 and connect. See Fig. 12. Check continuity between terminals No. 22 and 23 of SRS check harness connector No. 5.

4) Replace clockspring if any damage was found or continuity does not exist between specified terminals. See DRIVER-SIDE AIR BAG MODULE & CLOCKSPRING under REMOVAL & INSTALLATION.

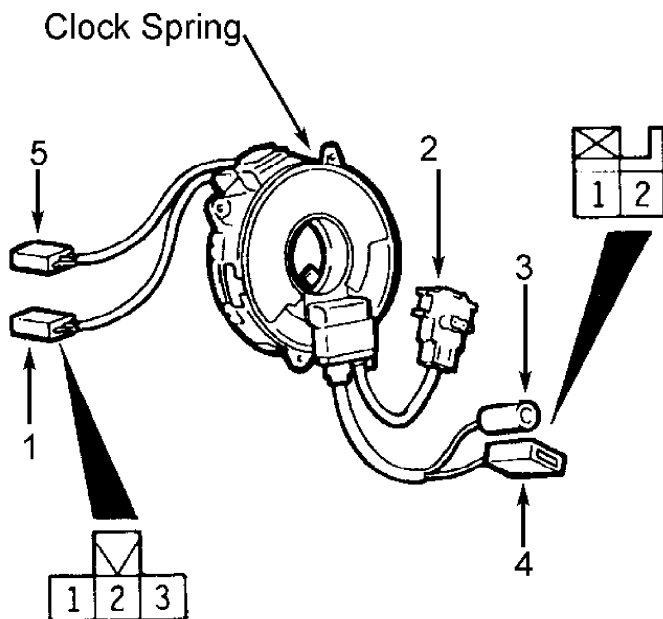

96D05650

Fig. 10: Identifying Clockspring Connectors  
Courtesy of Mitsubishi Motor Sales of America.

No.1 connector			No.3 connector	No.4 connector	
Terminal 1	Terminal 2	Terminal 3	Terminal 3	Terminal 1	Terminal 2
○					○
	○			○	
		○	○		
To auto-cruise control unit	To ACC power	To horn relay	To horn switch	To auto-cruise control switch	

96F05651

Fig. 11: Checking Continuity Between Clockspring Connectors  
 Courtesy of Mitsubishi Motor Sales of America.

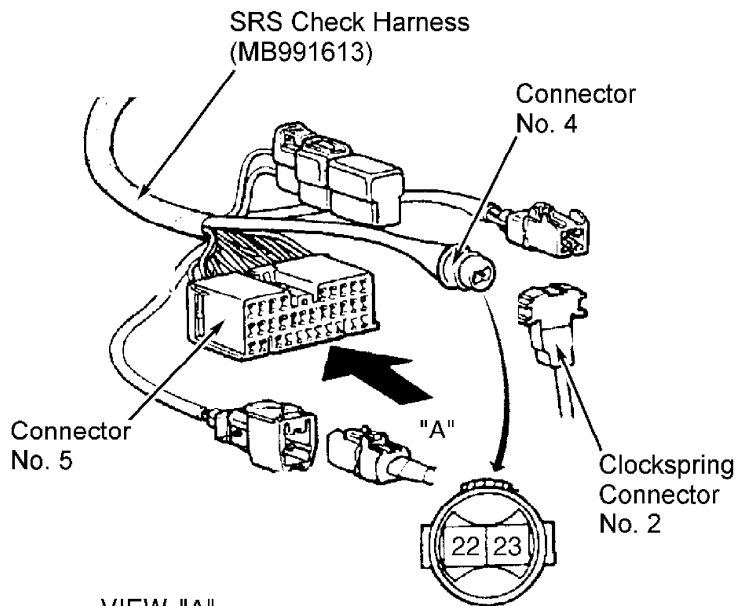

VIEW "A"

1	2	3	4			5	6	7	8	9		
10	11	12	13	14	15	16	17	18	19	20	21	
22	23		24	25	26	27	28	29	30		31	32

97105638

Fig. 12: Using SRS Check Harness To Test Clockspring & Connectors  
 Courtesy of Mitsubishi Motor Sales of America.

## WIRING DIAGRAMS

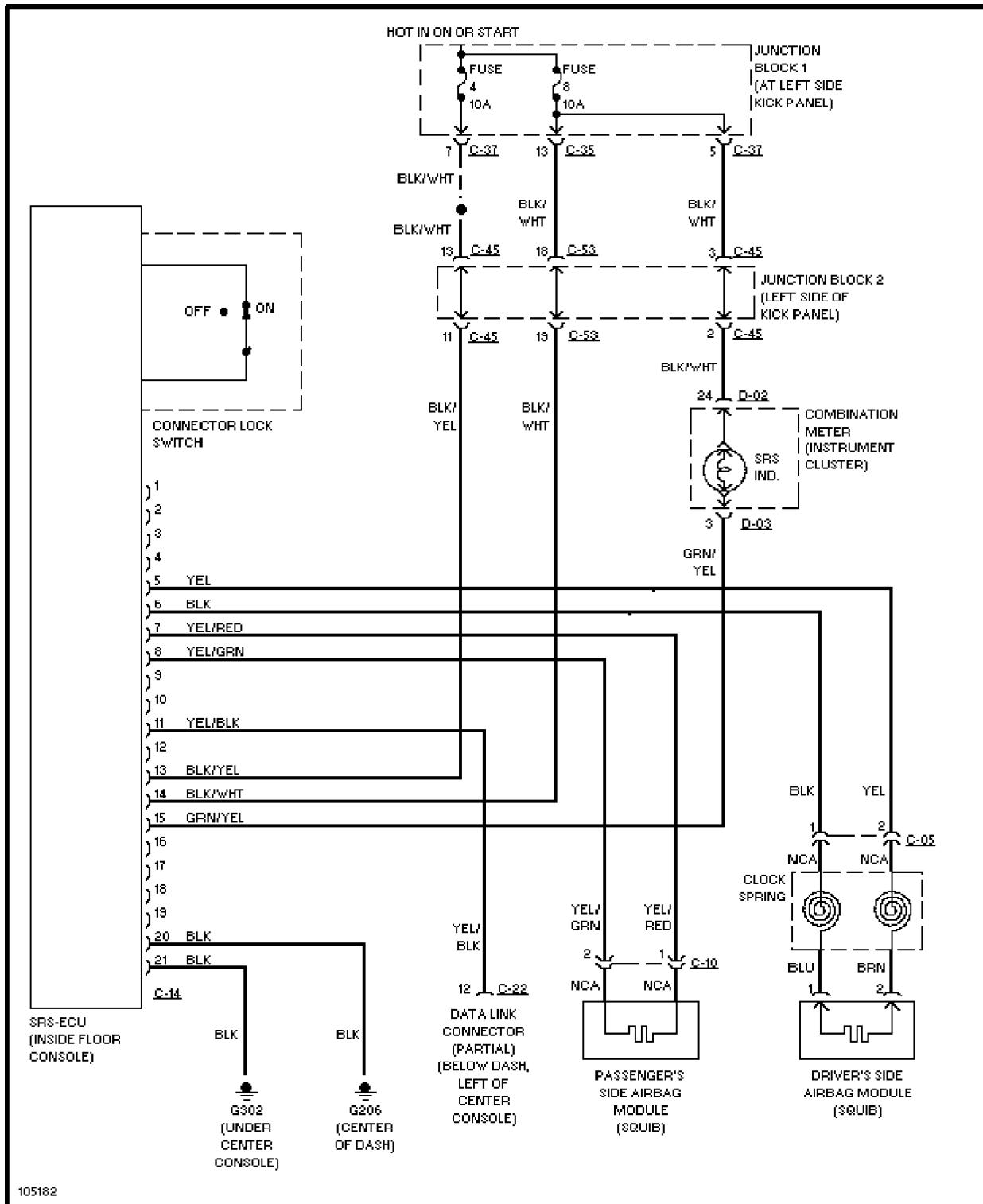

Fig. 13: SRS Wiring Diagram