

## GROUP 35A

# BASIC BRAKE SYSTEM

## CONTENTS

<b>GENERAL DESCRIPTION</b> . . . . .	<b>35A-2</b>	<b>BRAKE PEDAL</b> . . . . .	<b>35A-24</b>
<b>BASIC BRAKE SYSTEM DIAGNOSIS</b> <b>35A-3</b>		REMOVAL AND INSTALLATION . . . . .	35A-24
INTRODUCTION TO BASIC BRAKE SYSTEM DIAGNOSIS . . . . .	35A-3	INSPECTION . . . . .	35A-25
BASIC BRAKE SYSTEM DIAGNOSTIC TROUBLESHOOTING STRATEGY . . . . .	35A-3	<b>MASTER CYLINDER ASSEMBLY AND BRAKE BOOSTER</b> . . . . .	<b>35A-26</b>
SYMPTOM CHART . . . . .	35A-3	REMOVAL AND INSTALLATION . . . . .	35A-26
SYMPTOM PROCEDURES . . . . .	35A-4	MASTER CYLINDER . . . . .	35A-29
<b>SPECIAL TOOLS</b> . . . . .	<b>35A-12</b>	INSPECTION . . . . .	35A-29
<b>ON-VEHICLE SERVICE</b> . . . . .	<b>35A-13</b>	<b>DISC BRAKE ASSEMBLY</b> . . . . .	<b>35A-30</b>
BRAKE PEDAL CHECK AND ADJUSTMENT . . . . .	35A-13	REMOVAL AND INSTALLATION . . . . .	35A-30
BRAKE BOOSTER OPERATING TEST . . . . .	35A-14	INSPECTION . . . . .	35A-32
CHECK VALVE OPERATION CHECK . . . . .	35A-15	DISASSEMBLY AND ASSEMBLY <FRONT> . . . . .	35A-33
PROPORTIONING VALVE FUNCTION TEST <VEHICLES WITHOUT ABS> . . . . .	35A-16	DISASSEMBLY AND ASSEMBLY <REAR>	35A-36
BLEEDING . . . . .	35A-16	INSPECTION . . . . .	35A-38
BRAKE FLUID LEVEL SENSOR CHECK . . . . .	35A-18	<b>SPECIFICATIONS</b> . . . . .	<b>35A-40</b>
DISC BRAKE PAD CHECK AND REPLACEMENT . . . . .	35A-18	FASTENER TIGHTENING SPECIFICATIONS . . . . .	35A-40
DISC BRAKE ROTOR CHECK . . . . .	35A-20	GENERAL SPECIFICATIONS . . . . .	35A-40
MASTER CYLINDER FUNCTION CHECK . . . . .	35A-23	SERVICE SPECIFICATIONS . . . . .	35A-41
		LUBRICANTS . . . . .	35A-41

## GENERAL DESCRIPTION

M1351000100440

The brake system has been designed to give greater reliability and durability and to provide excellent braking performance.

### FEATURES

#### Improved braking performance

1. An 8+9 inch tandem brake booster provides sufficient braking force in sudden braking range.
2. 15-inch front ventilated disc brakes provide stable braking force and improved braking feel. <2.4L engine>
3. 16-inch front ventilated disc brakes provide stable braking force and improved braking feel. <3.8L engine>
4. 14-inch rear solid disc brakes are used.

#### Improved stability

1. A 4-wheel anti-lock braking system (4ABS) prevents slipping caused by the vehicle wheels locking up, in order to maintain a stable vehicle posture and steering performance.

2. An electronic brake-force distribution (EBD) makes it possible to maintain the maximum amount of braking force even when the vehicle's load is unevenly distributed. <Vehicles with ABS>
3. A rear wheel early lock-prevention proportioning valve are used. <Vehicles without ABS>
4. Front- and rear-wheel X-type brake line layout are used.
5. Ventilated discs on the front brakes improve anti-fading performance.

#### Improved serviceability

1. A diagnosis function for the ABS system makes inspection easier.
2. An outer disc separated hub and rotor make removal and installation easier.
3. The master cylinder reservoir tank cap is colored white to make identification easier.
4. The ABS-ECU and hydraulic unit are integrated to make them more compact and light weight.

### CONSTRUCTION DIAGRAM

<VEHICLE WITH ABS>

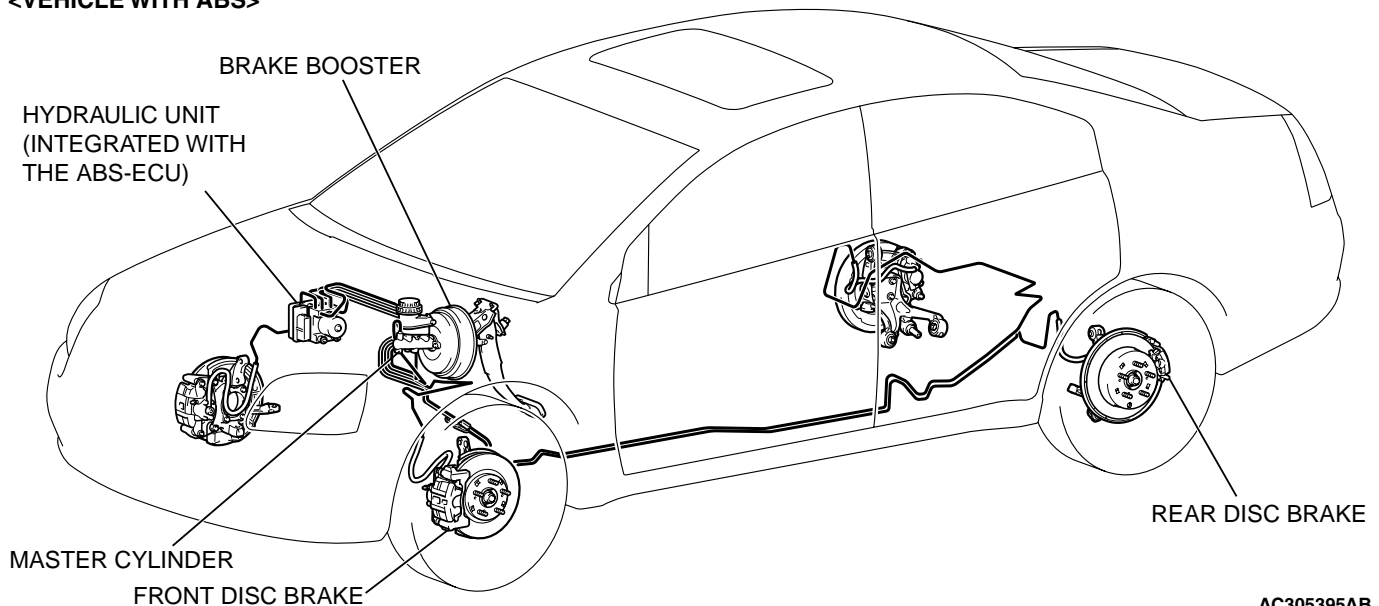

AC305395AB

<VEHICLE WITHOUT ABS>

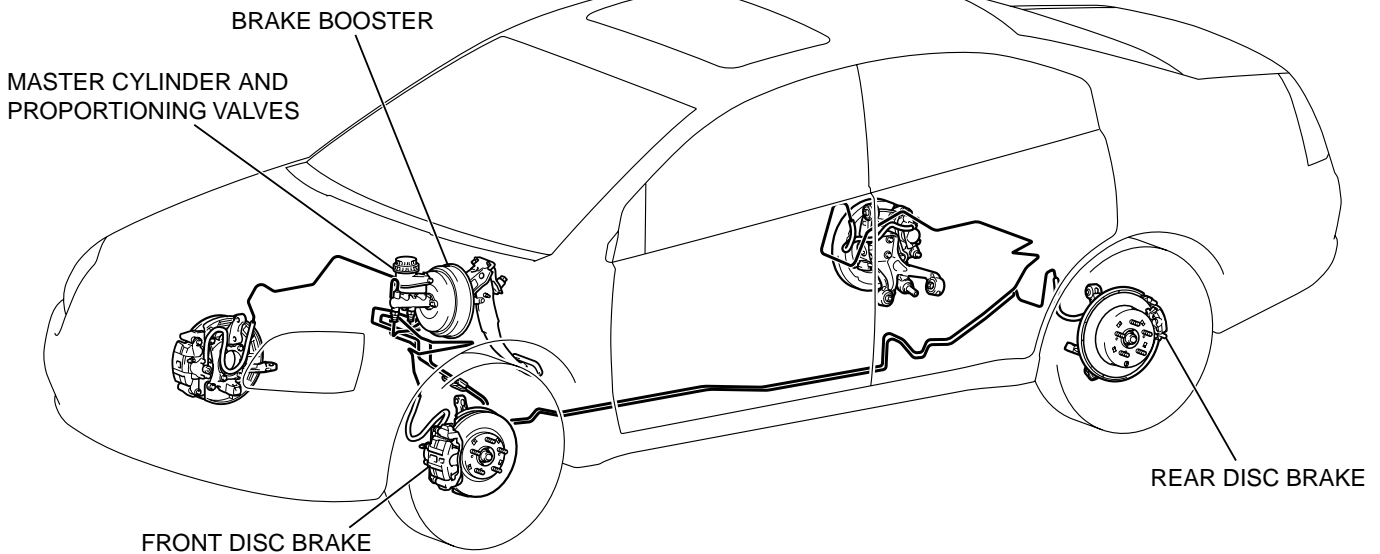

AC305394AB

## BASIC BRAKE SYSTEM DIAGNOSIS

### INTRODUCTION TO BASIC BRAKE SYSTEM DIAGNOSIS

M1351009700319

Hydraulic brakes are composed of the brake pedal, master cylinder, brake booster and disc brakes. Malfunctions such as insufficient braking power or the generation of noise may occur due to wear, damage or incorrect adjustment of these components.

### BASIC BRAKE SYSTEM DIAGNOSTIC TROUBLESHOOTING STRATEGY

M1351009800316

Use these steps to plan your diagnostic strategy. If you follow them carefully, you will be sure that you have exhausted most of the possible ways to find a basic brake system fault.

1. Gather information from the customer.

2. Verify that the condition described by the customer exists.
3. Find the malfunction by following the symptom chart.
4. Verify malfunction is eliminated.

### SYMPTOM CHART

M1351009900324

SYMPTOM	INSPECTION PROCEDURE	REFERENCE PAGE
Vehicle pulls to one side when brakes are applied	1	<a href="#">P.35A-4</a>
Insufficient braking power	2	<a href="#">P.35A-4</a>
Increased pedal stroke (Reduced pedal-to-floor board clearance)	3	<a href="#">P.35A-5</a>
Brake drag	4	<a href="#">P.35A-6</a>
Scraping or grinding noise when brake are applied	5	<a href="#">P.35A-7</a>
Squealing, groaning or chattering noise when brake are applied	6	<a href="#">P.35A-8</a>
Squealing noise when brakes are not applied	7	<a href="#">P.35A-9</a>
Groaning, clicking or rattling noise when brakes are not applied	8	<a href="#">P.35A-11</a>

## SYMPTOM PROCEDURES

## INSPECTION PROCEDURE 1: Vehicle Pulls to One Side when Brakes are Applied

## DIAGNOSIS

**STEP 1. Check for oil, water, etc., on the pad contact surface of all brakes.****Q: Is oil, water, etc., on the pad contact surface?****YES :** Replace the part and determine the source/cause of foreign material. Then go to Step 5.**NO :** Go to Step 2.**STEP 2. Check disc brake pistons for smooth operation.**

- (1) With engine not running, depress the brake pedal rapidly several times to deplete booster vacuum reserves.
- (2) Test each disc brake assembly one at a time.
  - a. Remove the lower caliper bolt, then remove caliper from mount.
  - b. Have an assistant slowly depress the brake pedal. Confirm piston(s) extend slowly and smoothly with no jumpiness. Repeat for each disc brake assembly.

**Q: Do (does) the piston(s) move correctly?****YES :** Go to Step 3.**NO :** Disassemble and inspect the brake assembly (Front: refer to [P.35A-33](#), Rear: refer to [P.35A-36](#)). Then go to Step 5.**STEP 3. Check brake disc(s) for runout.**Refer to [P.35A-20](#).**Q: Is runout outside of specifications?****YES :** Repair or replace the brake disc(s) as necessary. Then go to Step 5.**NO :** Go to Step 4.**STEP 4. Check brake discs for correct thickness.**Refer to [P.35A-20](#).**Q: Is the thickness outside of specifications?****YES :** Repair or replace the brake disc(s) as necessary. Then go to Step 5.**NO :** Perform the brake line bleeding. Then go to Step 5.**STEP 5. Retest the system.****Q: Is the symptom eliminated?****YES :** The procedure is complete.**NO :** Start over at Step 1. If a new symptom appears, refer to the appropriate symptom chart.

## INSPECTION PROCEDURE 2: Insufficient Braking Power

## DIAGNOSIS

**STEP 1. Check that the specified brake fluid is used, its level is correct, and no contamination is found.****Q: Is there a fault?****YES :** Refill or replace with the specified brake fluid DOT 3 or DOT 4. Bleed the brakes if necessary (Refer to [P.35A-16](#)). Then go to Step 7.**NO :** Go to Step 2.**STEP 2. Check for spongy (not firm) brakes.**

- (1) With engine not running, depress the brake pedal rapidly several times to deplete the booster vacuum reserve.
- (2) With the brake pedal fully released, depress the brake pedal slowly until it stops.
- (3) With a measuring device (ruler, etc.) next to the brake pedal, depress the pedal firmly and measure the distance the pedal traveled.

**Q: Is the distance greater than 20 mm (0.8 inch)?****YES :** Bleed the brakes to remove air in the fluid (Refer to [P.35A-16](#)). Then go to Step 7.**NO :** Go to Step 3.

---

**STEP 3. Check the brake booster function.**

Refer to [P.35A-14](#).

**Q: Is there a fault?**

**YES :** Replace the brake booster. Then go to Step 7.

**NO :** Go to Step 4.

---

**STEP 4. Check for pinched or restricted brake tube or hose.**

**Q: Is there a pinched or restricted brake tube or hose?**

**YES :** Replace that complete section of brake tube or brake hose. Then go to Step 7.

**NO :** Go to Step 5.

---

**STEP 5. Check for oil, water, etc., on the pad contact surfaces of all brakes.**

**Q: Is oil, water, etc., on the pad contact surface?**

**YES :** Replace the part and determine the source/cause of foreign material. Recheck symptom. Then go to Step 7.

**NO :** The procedure is complete. If condition persists for vehicles without ABS, go to Step 6.

---

**STEP 6. Check the proportioning valve operation.  
<Vehicles without ABS>**

Refer to [P.35A-16](#).

**Q: Is there a fault?**

**YES :** Replace the proportioning valve. Then go to Step 7.

**NO :** Go to Step 7.

---

**STEP 7. Recheck symptom.**

**Q: Is the symptom eliminated?**

**YES :** The procedure is complete.

**NO :** Start over at step 1. If a new symptom surfaces, refer to the appropriate symptom chart.

---

**INSPECTION PROCEDURE 3: Increased Pedal Stroke (Reduced Pedal-to-Floor Board Clearance)**

---

**DIAGNOSIS**

---

**STEP 1. Check for spongy (not firm) brakes.**

(1) With engine not running, depress the brake pedal rapidly several times to deplete booster vacuum reserve.

(2) With the brake pedal fully released, depress the brake pedal slowly until it stops.

(3) With a measuring device (ruler, etc.) next to the brake pedal, depress the pedal firmly and measure the distance the pedal traveled.

**Q: Is the distance greater than 20 mm (0.8 inch)?**

**YES :** Bleed the brakes to remove air in the fluid (Refer to [P.35A-16](#)). Then go to Step 7.

**NO :** Go to Step 2.

---

**STEP 2. Check the pad for wear.**

Refer to [P.35A-18](#).

**Q: Is the pad thickness outside of specifications?**

**YES :** Replace the part. Then go to Step 7.

**NO :** Go to Step 3.

---

**STEP 3. Check the vacuum hose and check valve for damage.**

Refer to [P.35A-15](#).

**Q: Is there a damage?**

**YES :** Replace the part. Then go to Step 7.

**NO :** Go to Step 4.

---

**STEP 4. Check the master cylinder function.**

Refer to [P.35A-23](#).

**Q: Is there a fault?**

**YES :** Repair it. Then go to Step 7.

**NO :** Go to Step 5.

---

**STEP 5. Check for brake fluid leaks.**

**Q: Is there a leak?**

**YES :** Check the connection for looseness, corrosion, etc. Clean and repair as necessary. If leaking in any tube or hose section, replace the complete tube or hose. Then go to Step 7.

**NO :** Go to Step 6.

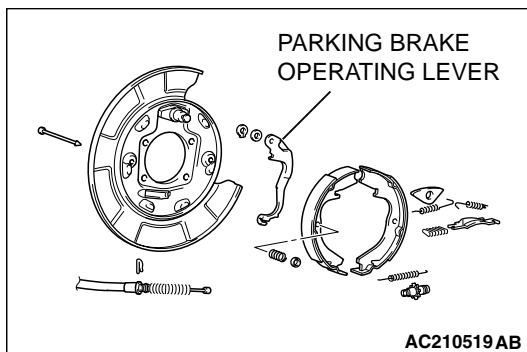
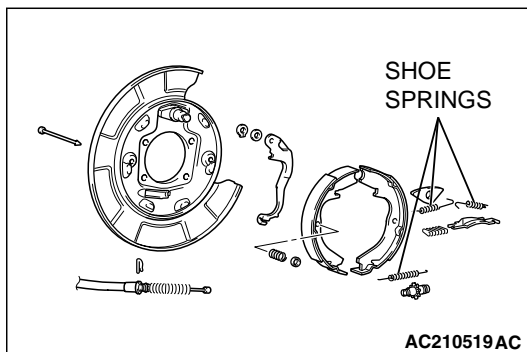
**STEP 6. Check for excessive clearance between the push rod and primary piston.**Refer to [P.35A-26](#).**Q: Is the clearance outside of specifications?****YES :** Adjust the clearance. Then go to Step 7.**NO :** Go to Step 7.**STEP 7. Recheck symptom.****Q: Is the symptom eliminated?****YES :** The procedure is complete.**NO :** Start over at step 1. If a new symptom surfaces, refer to the symptom chart.**INSPECTION PROCEDURE 4: Brake Drag****DIAGNOSIS****STEP 1. Check the parking brake operating lever return.****Q: Is the operation faulty?****YES :** Repair it. Then go to Step 9.**NO :** Go to Step 2.**STEP 2. Check the brake shoe springs for breakage.****Q: Are the brake shoe springs broken?****YES :** Replace the spring. Then go to Step 9.**NO :** Go to Step 3.**STEP 3. Check the amount of grease at each sliding section.**Refer to GROUP 36, Parking Brake Lining and Drum [P.36-8](#).**Q: Is the grease amount low?****YES :** Apply grease. Then go to Step 9.**NO :** Go to Step 4.**STEP 4. Check the parking brake pull amount.**Refer to GROUP 36, On-vehicle Service – Parking Brake lever Stroke Check and Adjustment [P.36-3](#).**Q: Is there a fault?****YES :** Adjust it. Then go to Step 9.**NO :** Go to Step 5.

---

**STEP 5. Check for insufficient clearance between the push rod and primary piston.**

Refer to [P.35A-26](#).

**Q: Is there a fault?**

**YES** : Adjust the clearance. Then go to Step 9.

**NO** : Go to Step 6.

---

**STEP 6. Check the master cylinder piston return spring for damage and return port for clogging.**

Refer to [P.35A-29](#).

**Q: Is there damage?**

**YES** : Replace the part. Then go to Step 9.

**NO** : Go to Step 7.

---

**STEP 7. Check port for clogging.**

**Q: Is the port clogged?**

**YES** : Repair it. Then go to Step 9.

**NO** : Go to Step 8.

---

**STEP 8. Check disc brake pistons for sticking.**

Depress the brake pedal, then release. Confirm each wheel spins freely.

**Q: Does any wheel stick?**

**YES** : Inspect that brake assembly. Then go to Step 9.

**NO** : Go to Step 9.

---

**STEP 9. Recheck symptom.**

**Q: Is the symptom eliminated?**

**YES** : The procedure is complete.

**NO** : Start over at step 1. If a new symptom surfaces, refer to the symptom chart.

---

## INSPECTION PROCEDURE 5: Scraping or Grinding Noise when Brakes are Applied

---

### DIAGNOSIS

---

**STEP 1. Check the front brakes, then rear brakes, for metal-to-metal condition.**

**Q: Is any metal-to-metal contact evident?**

**YES** : Repair or replace the components. Then go to Step 6.

**NO** : Go to Step 2.

---

**STEP 2. Check for interference between the caliper and wheel.**

**Q: Is there any interference?**

**YES** : Repair or replace the part. Then go to Step 6.

**NO** : Go to Step 3.

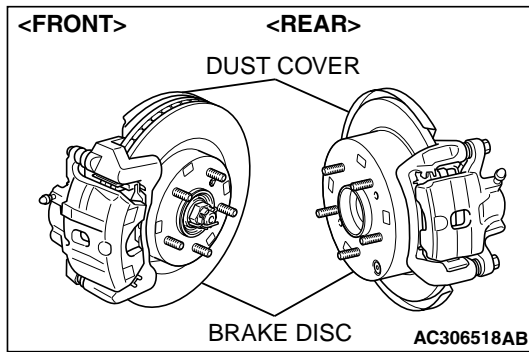

**STEP 3. Check for interference between the dust cover and brake disc.**

**Q: Is there any interference?**

**YES :** Repair or replace the part. Then go to Step 6.

**NO :** Go to Step 4.

**STEP 4. Check the brake drums or discs for cracks.**

**Q: Are there cracks?**

**YES :** Repair or replace the part. Then go to Step 6.

**NO :** Go to Step 5.

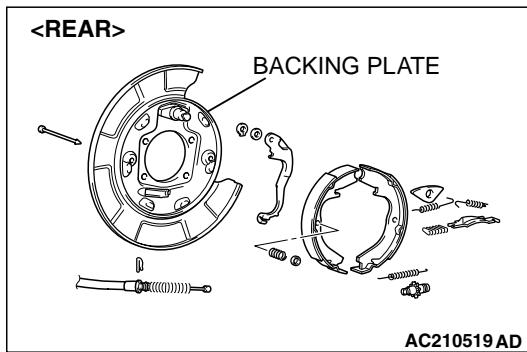

**STEP 5. Check for bent backing plate(s).**

**Q: Is (Are) the backing plate(s) bent?**

**YES :** Repair or replace the part. Then go to Step 6.

**NO :** Go to Step 6.

**STEP 6. Recheck symptom.**

**Q: Is the symptom eliminated?**

**YES :** The procedure is complete.

**NO :** Start over at step 1. If a new symptom surfaces, refer to the symptom chart.

## INSPECTION PROCEDURE6: Squealing, Groaning or Chattering Noise when Brakes are Applied

### DIAGNOSIS

**STEP 1. Check the brake disc and pads for wear or cutting.**

**Q: Is there wear or cutting?**

**YES :** Repair or replace the part. Then go to Step 4.

**NO :** Go to Step 2.

**STEP 2. Check the calipers for rust.**

**Q: Is there any rust?**

**YES :** Remove the rust. Then go to Step 4.

**NO :** Go to Step 3.



---

**STEP 3. Adjust the brake pedal or brake booster pushrod.**

Refer to [P.35A-13](#) or [P.35A-26](#).

**Q: Are the brake pedal and the brake booster pushrod adjusted correctly?**

**YES :** Go to Step 4.

**NO :** Adjust the brake pedal or the brake booster pushrod. Then go to Step 4.

---

**STEP 4. Recheck symptom.**

**Q: Is the symptom eliminated?**

**YES :** The procedure is complete.

**NO :** Start over at step 1. If a new symptom surfaces, refer to the symptom chart.

---

**INSPECTION PROCEDURE 7: Squealing Noise when Brakes are not Applied**

---

**DIAGNOSIS**

---

**STEP 1. Check whether the backing plate is bent or loose and interfering with the drum.**

**Q: Is there a fault?**

**YES :** Replace the part. Then go to Step 10.

**NO :** Go to Step 2.

---

**STEP 2. Check whether the drum is damaged due to interference with the backing plate or shoe.**

**Q: Is there any damage?**

**YES :** Replace the part. Then go to Step 10.

**NO :** Go to Step 3.

---

**STEP 3. Check the brake drum for wear and the shoe spring for damage.**

**Q: Is there any wear or damage?**

**YES :** Replace the part. Then go to Step 10.

**NO :** Go to Step 4.

---

**STEP 4. Check the brake discs for rust.**

**Q: Are the brake discs rusted?**

**YES :** Remove the rust by using sand paper. If still rusted, turn the rotors with an on-the-car brake lathe. Then go to Step 10.

**NO :** Go to Step 5.

---

**STEP 5. Check the brake pads for correct installation.**

**Q: Are the pads installed incorrectly?**

**YES :** Repair the pads. Then go to Step 10.

**NO :** Go to Step 6.

---

**STEP 6. Check the calipers for correct installation.**

**Q: Are the calipers installed incorrectly?**

**YES :** Repair the calipers. Then go to Step 10.

**NO :** Go to Step 7.

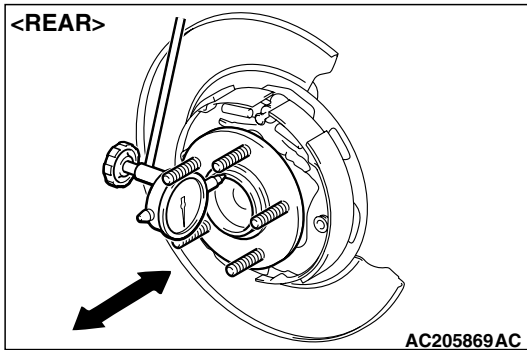
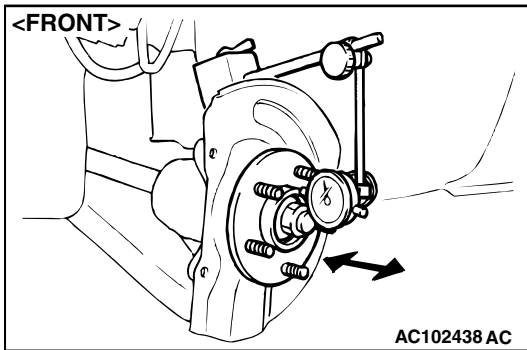
**STEP 7. Check the wheel bearings for end play.**

- (1) Remove the brake discs.
- (2) Place a dial gauge as shown, and measure the end play while moving the hub in the axial direction.

**Limit: 0.05 mm (0.002 inch)**

**Q: Does the measured end play exceed the limit?**

- YES** : Replace the faulty hub assembly. Then go to Step 10.  
**NO** : Go to Step 8.

**STEP 8. Check whether the brake booster or master cylinder return is insufficient.****Q: Is the brake booster or master cylinder return insufficient?**

- YES** : Replace the part. Then go to Step 10.  
**NO** : Go to Step 9.

**STEP 9. Adjust the brake pedal or brake booster pushrod.**  
Refer to [P.35A-13](#) or [P.35A-26](#).**Q: Are the brake pedal and the brake booster pushrod adjusted correctly?**

- YES** : Go to Step 10.  
**NO** : Adjust the brake pedal or the brake booster pushrod. Then go to Step 10.

**STEP 10. Recheck symptom.****Q: Is the symptom eliminated?**

- YES** : The procedure is complete.  
**NO** : Start over at step 1. If a new symptom surfaces, refer to the symptom chart.

**INSPECTION PROCEDURE 8: Groaning, Clicking or Rattling Noise when Brakes are not Applied.**

**DIAGNOSIS**

**STEP 1. Check whether foreign material has entered the wheel covers.**

**Q: Is there any foreign material?**

**YES :** Remove it. Then go to Step 5.

**NO :** Go to Step 2.

**STEP 2. Check for looseness of the wheel nuts.**

**Q: Are the wheel nuts loose?**

**YES :** Tighten to  $98 \pm 10$  N·m ( $73 \pm 7$  ft-lb). Then go to Step 5.

**NO :** Go to Step 3.

**STEP 3. Check for looseness of the caliper installation bolt.**

**Q: Is the caliper installation bolt loose?**

**YES :** Tighten to  $100 \pm 10$  N·m ( $74 \pm 7$  ft-lb) for the front caliper. Tighten to  $60 \pm 5$  N·m ( $45 \pm 3$  ft-lb) for the rear caliper. Then go to Step 5.

**NO :** Go to Step 4.

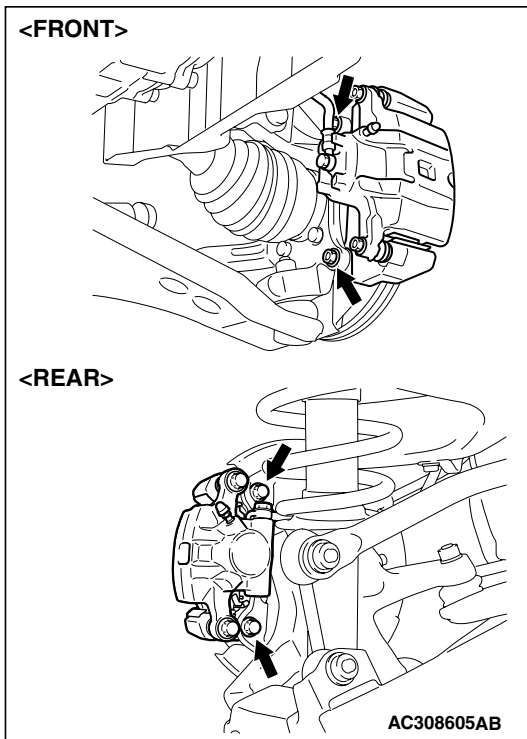

**STEP 4. Check the wheel bearings for end play.**

- (1) Remove the brake discs.
- (2) Place a dial gauge as shown, and measure the end play while moving the hub in the axial direction.

**Limit: 0.05 mm (0.002 inch)**

**Q: Does the measured end play exceed the limit?**

- YES :** Replace the faulty hub assembly. Then go to Step 5.
- NO :** Go to Step 5.

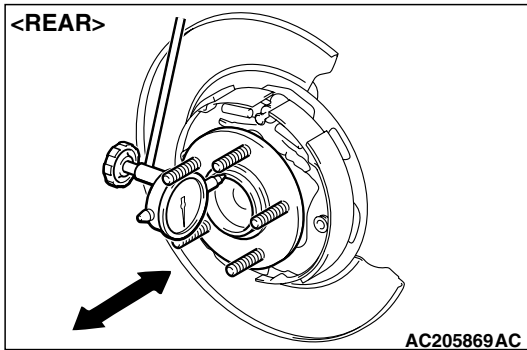
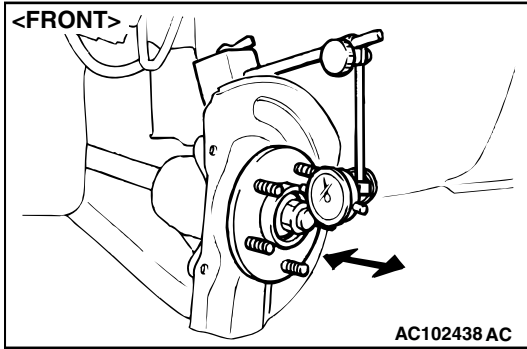

**STEP 5. Recheck symptom.**

**Q: Is the symptom eliminated?**

- YES :** The procedure is complete.
- NO :** Start over at step 1. If a new symptom surfaces, refer to the symptom chart.

**SPECIAL TOOLS**

M135100600360

TOOL	TOOL NUMBER AND NAME	SUPERSESSION	APPLICATION
	MB991568 Push rod adjusting socket	General service tool	Adjustment of the brake booster push rod protrusion amount
	MB990964 Brake tool set A: MB990520 Disc brake piston expander	MB990620-01 or general service tool	Pushing-in of the disc brake piston

## ON-VEHICLE SERVICE

### BRAKE PEDAL CHECK AND ADJUSTMENT

M1351000900446

#### BRAKE PEDAL HEIGHT

1. Turn up the carpet, etc. under the brake pedal.
2. Measure the brake pedal height as illustrated.

**Standard value: 169.8 – 172.8 mm (6.69 – 6.80 inches)**  
**[From the surface of dash panel to the face of pedal pad]**

3. If the brake pedal height is not within the standard value, follow the procedure below.

- (1) Disconnect the stoplight switch connector.
- (2) Remove the brake booster (Refer to [P.35A-26](#)).

*NOTE: With the master cylinder and brake pipe connected, remove the brake booster only.*

- (3) Adjust the brake pedal height by turning the clevis.

*NOTE: When the clevis is turned 180 degrees, the pedal height is changed by approximately 2.2 mm (0.09 in).*

- (4) Install the brake booster (Refer to [P.35A-26](#)).
- (5) Measure the brake pedal height, and ensure that the measured value is within the specified value. If it is out of the specified value, repeat Step (3) - (6).

- (6) Screw in the stop light switch until its thread contacts the stopper, and fix the stop light switch by turning it approximately one quarter of a turn clockwise.

- (7) Check that the clearance between the stop light switch and the stopper is as shown.

#### **CAUTION**

**Check that the stop light does not illuminate when the brake pedal is not depressed.**

- (8) Connect the connector at the stop light switch.

4. Check the key interlock and shift lock mechanisms. (Refer to GROUP 23A, On-vehicle Service – Key Interlock and Shift Lock Mechanism Check [P.23A-378](#)).

5. Return the carpet, etc. to its original position.

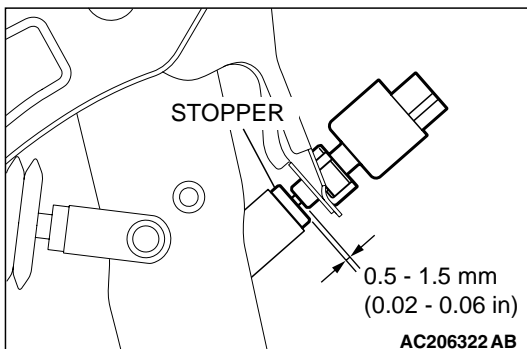
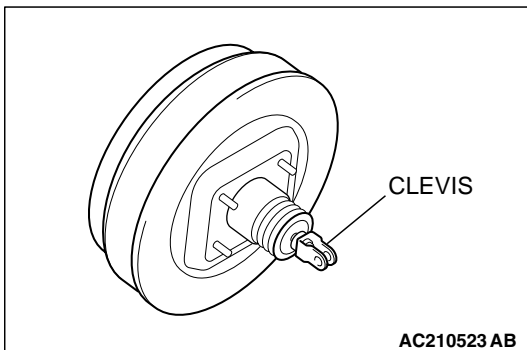
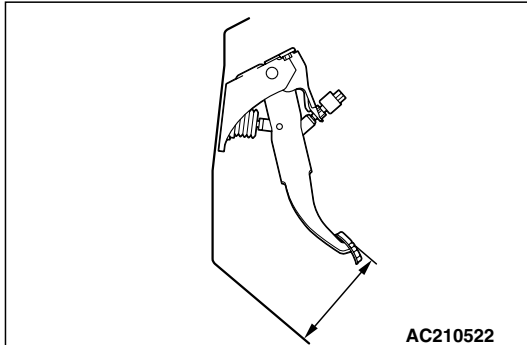

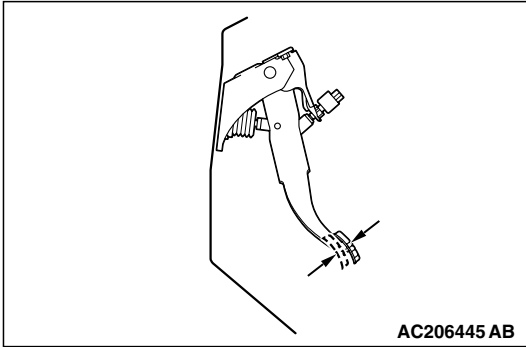

1. Turn the ignition switch to the "LOCK" (OFF) position, and depress the brake pedal two or three times. After eliminating the vacuum in the brake booster, press the pedal down by hand, and confirm that the amount of movement before resistance is met (free play) is within the standard value range.

**Standard value: 3 – 8 mm (0.12 – 0.31 inch)**

2. If the brake pedal play is not within the standard value, check the following, and adjust or replace if necessary:
  - Excessive play between the brake pedal and the clevis pin, or between the clevis pin and the brake booster operating rod
  - Brake pedal height
  - Installation position of the stop light switch, etc.

### CLEARANCE BETWEEN BRAKE PEDAL AND DASH PANEL

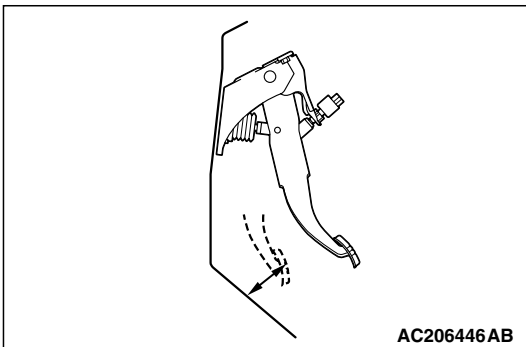

1. Turn up the carpet, etc. under the brake pedal.
2. Start the engine, depress the brake pedal with approximately 500 N (112 pounds) of force, and measure the clearance between the brake pedal and the dash panel.

**Standard value: 110 mm (4.33 inches) or more [From the surface of dash panel to the face of pedal pad]**

3. If the clearance is outside the standard value, check for air trapped in the brake line and check the thickness of the disc brake pad. Adjust and replace defective parts as required.
4. Return the carpet etc. to its original position.

### BRAKE BOOSTER OPERATING TEST

M1351001000372

1. For simple checking of the brake booster operation, carry out the following tests:
  - (1) Run the engine for one or two minutes, and then stop it. If the pedal depresses fully the first time but gradually becomes higher when depressed succeeding times, the booster is operating properly. If the pedal height remains unchanged, the booster is defective. Go to step 2.

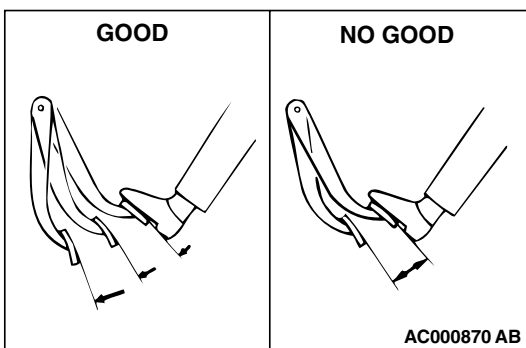

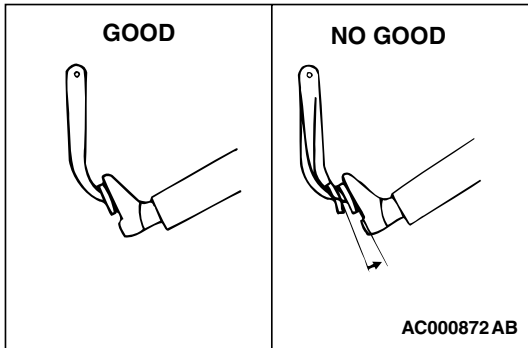
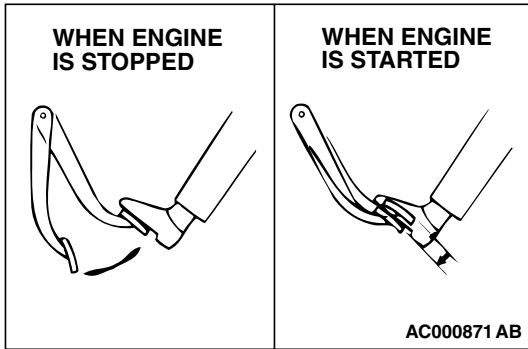

(2) With the engine stopped, step on the brake pedal several times. Then step on the brake pedal and start the engine. If the pedal moves downward slightly, the booster is in good condition. If there is no change, the booster is defective. Go to step 3.

(3) With the engine running, step on the brake pedal and then stop the engine. Hold the pedal depressed for 30 seconds. If the pedal height does not change, the booster is in good condition, if the pedal rises, the booster is defective.

2. If the above three tests are okay, the booster is OK. If one of the above three tests is not okay, the check valve, vacuum hose, or booster is defective. Check the check valve (Refer to P.35A-15), vacuum hose for leaks, high volume engine vacuum applied to booster. Repair or replace as necessary. If these are OK, replace booster and repeat this test starting at Step 1.

**CHECK VALVE OPERATION CHECK**

M1351009000376

**⚠ CAUTION**

The check valve should not be removed from the vacuum hose.

1. Remove the vacuum hose. (Refer to P.35A-26).

**⚠ CAUTION**

If the check valve is defective, replace it as an assembly together with the vacuum hose.

2. Check the operation of the check valve by using a vacuum pump.

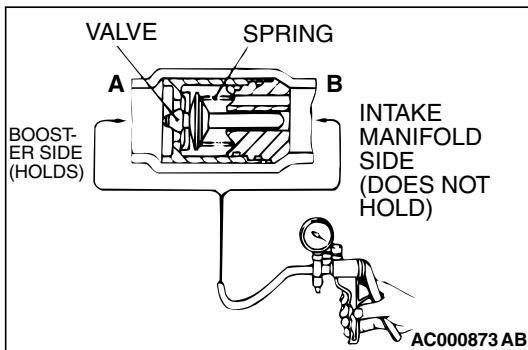

VACUUM PUMP CONNECTION	CRITERIA
Connection at the brake booster side (A)	A negative pressure (vacuum) is created and held.
Connection at the intake manifold side (B)	A negative pressure (vacuum) is not created.

## PROPORTIONING VALVE FUNCTION TEST <VEHICLES WITHOUT ABS>

M1351001100346

### CAUTION

The proportioning valves are installed independently for the right and left brake lines. Always measure each valve.

1. Connect two pressure gauges to the output port of the master cylinder and output port of the proportioning valve.
2. Bleed the brake line and the pressure gauges (Refer to P.35A-16).

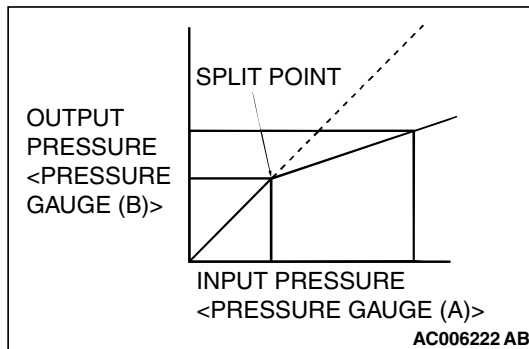
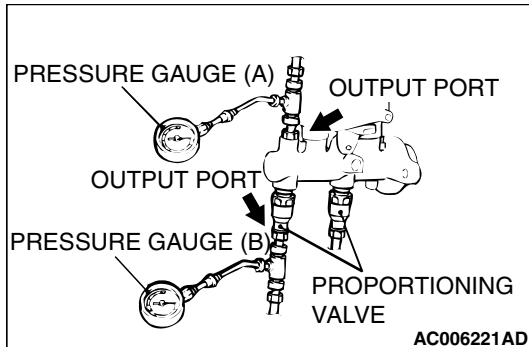

3. Depress the brake pedal gradually. Then check that the split point, where the output fluid pressure begins to drop in proportion to the output fluid pressure, is at the standard value.

**Standard value: 3.68 – 4.17 MPa (534 – 605 psi)**

4. Depress the brake pedal more strongly than at the above step. Then check that the output fluid pressure is at the standard value when the input fluid pressure is 7.85 MPa (1,139 psi).

**Standard value: 5.24 – 5.74 MPa (760 – 833 psi)**

5. Measure each output fluid pressure at both valves, and check that the difference between the two is at the limit value or less.

**Limit: 0.5 MPa (73 psi)**

6. If the measured pressure exceeds the limit, replace the proportioning valve.

## BLEEDING

M1351001400455

### CAUTION

Use only brake fluid DOT 3 or DOT 4. Never mix the specified brake fluid with other fluid as it will influence the braking performance significantly.

## MASTER CYLINDER BLEEDING

The master cylinder used has no check valve, so if bleeding is carried out by the following procedure, bleeding of air from the brake pipeline will become easier. (When brake fluid is not contained in the master cylinder).

1. Fill the reserve tank with brake fluid.
2. Keep the brake pedal depressed.



**VEHICLES WITH ABS**

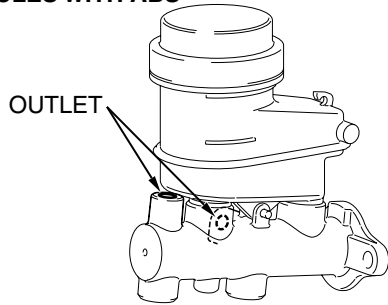

**VEHICLES WITHOUT ABS**

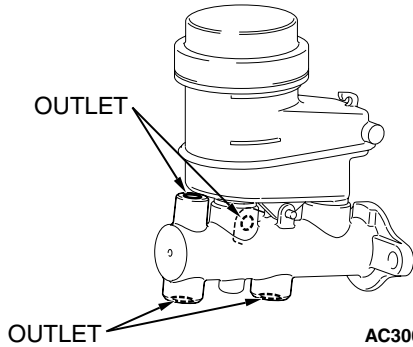

AC306134AB

3. Have another person cover the master cylinder outlet with a finger.
4. With the outlet still closed, release the brake pedal.
5. Repeat steps 2 – 4 three or four times to fill the inside of the master cylinder with brake fluid.

**VEHICLES WITH ABS**

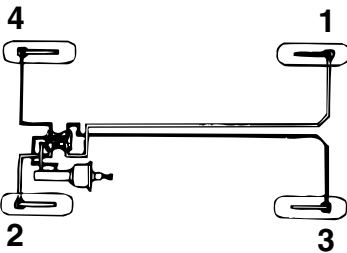

**VEHICLES WITHOUT ABS**

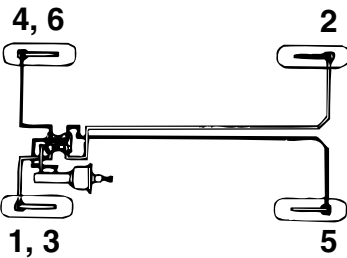

AC006223AB

**BRAKE LINE BLEEDING**

Start the engine and bleed the air in the sequence shown in the figure.

**BRAKE FLUID LEVEL SENSOR CHECK**

M1351009100403

The brake fluid level sensor is in good condition if there is no continuity when the float surface is above "MIN" and if there is continuity when the float surface is below "MIN".

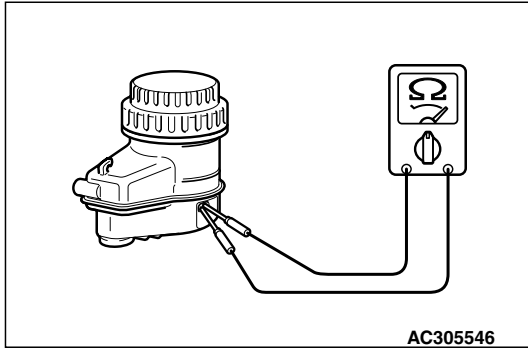

AC305546

**DISC BRAKE PAD CHECK AND REPLACEMENT**

M1351002300398

*NOTE: The brake pads (LH wheel) have indicators that contact the brake disc when the brake pad thickness becomes 2 mm (0.08 inch), and emit a squealing sound to warn the driver.*

**CAUTION**

- Whenever a pad must be replaced, replace both LH and RH wheel pads as a set to prevent the vehicle from pulling to one side when braking.
- If there is a significant difference in the thicknesses of the pads on the left and right sides, check the sliding condition of the piston and slide pins.

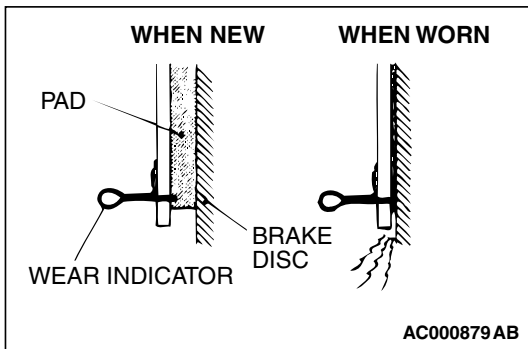

AC000879 AB

1. Check the brake pad thickness through the caliper body check port.

**Standard value: 10.0 mm (0.39 inch)**

**Minimum limit: 2.0 mm (0.08 inch)**

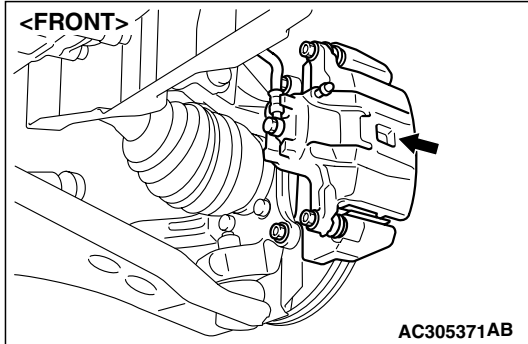

AC305371AB

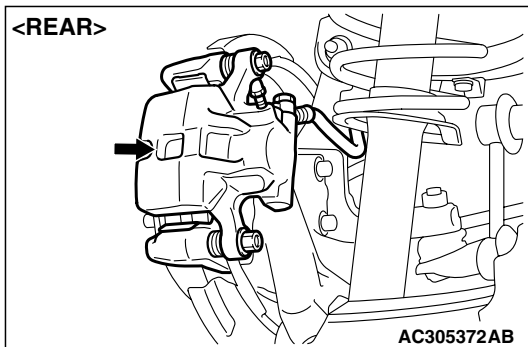

AC305372AB

**⚠ CAUTION**

Do not wipe off the special grease that is on the lock pin.  
Do not contaminate the lock pin.

2. Remove the lock pin bolt <Front> or lock pin and brake hose clamp <Rear>. Pivot the caliper assembly and hold it with wires.

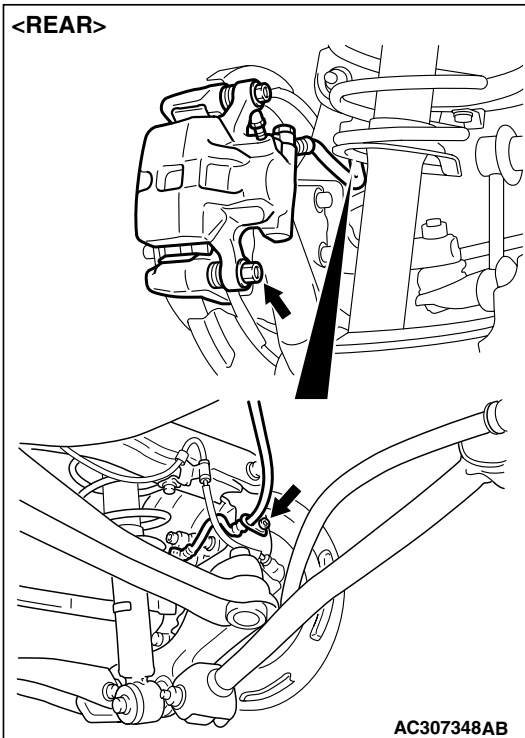
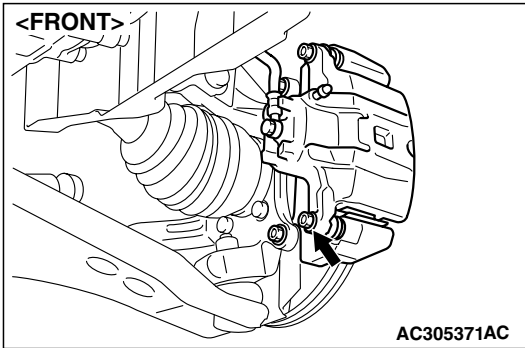

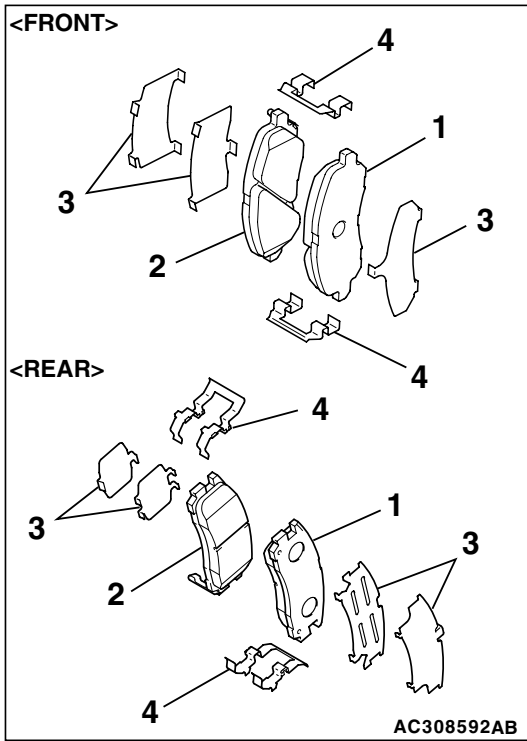

3. Remove the following parts from the caliper support.
  - (1) Pad assembly
  - (2) Pad and wear indicator assembly or Pad assembly
  - (3) Shim
  - (4) Clip
4. In order to measure the brake drag force after pad installation, measure the rotary-sliding resistance of the hub with the pads removed (Refer to P.35A-30).
5. Install the pads and caliper assembly, and then check the brake drag force (Refer to P.35A-30).

**DISC BRAKE ROTOR CHECK**

M1351002900334

**⚠ CAUTION**

Disc brakes must be kept within the allowable service values in order to maintain normal brake operation.

Before turning the brake disc, the following conditions should be checked.

INSPECTION ITEM	REMARK
Scratches, rust, saturated lining materials and wear	<ul style="list-style-type: none"> <li>• If the vehicle is not driven for a long period of time, sections of the discs that are not in contact with the pads will become rusty, causing noise and shuddering.</li> <li>• If grooves and scratches resulting from excessive disc wear are not removed prior to installing a new pad assembly, there will be inadequate contact between the disc and the lining (pad) until the pads conform to the disc.</li> </ul>
Run-out	Excessive run-out of the discs will increase the pedal depression resistance due to piston kick-back.
Change in thickness (parallelism)	If the thickness of the disc changes, this will cause pedal pulsation, shuddering and surging.
Inset or warping (flatness)	Overheating and improper handling while servicing will cause warping or distortion.

## BRAKE DISC THICKNESS CHECK

1. Using a micrometer, measure disc thickness at eight positions, approximately 45 degrees apart and 10 mm (0.4 inch) in from the outer edge of the disc.

### FRONT BRAKE DISC

Standard value: 26.0 mm (1.02 inches)

Minimum limit: 24.4 mm (0.96 inch)

### REAR BRAKE DISC

Standard value: 10.0 mm (0.39 inch)

Minimum limit: 8.4 mm (0.33 inch)

*NOTE: Thickness variation (at least 8 positions) should not be more than 0.015 mm (0.0006 inch).*

### CAUTION

- After a new brake disc is installed, always grind the brake disc with an on-the-car type brake lathe. If this step is not carried out, the brake disc run-out exceeds the specified value, resulting in judder.
  - When the on-the-car type lathe is used, first install a M12 flat washer on the stud bolt in the brake disc side according to the figure, and then install the adapter. If the adapter is installed with M12 flat washer not seated, the brake disc rotor may be deformed, resulting in inaccurate grinding.
  - Grind the brake disc with all wheel nuts diagonally and equally tightened to the specified torque 100 N·m (74 ft-lb). If all of the wheel nuts are not used, or the tightening torque is excessive or not equal, the brake disc rotor or drum may be deformed, resulting in judder.
2. If the disc thickness is less than the limit, replace it with a new one. If thickness variation exceeds the specification, turn rotor with an on-the-car type brake lathe ("Accutum-8750" or equivalent). If the calculated final thickness after turning the rotor is less than the standard value, replace the disc.

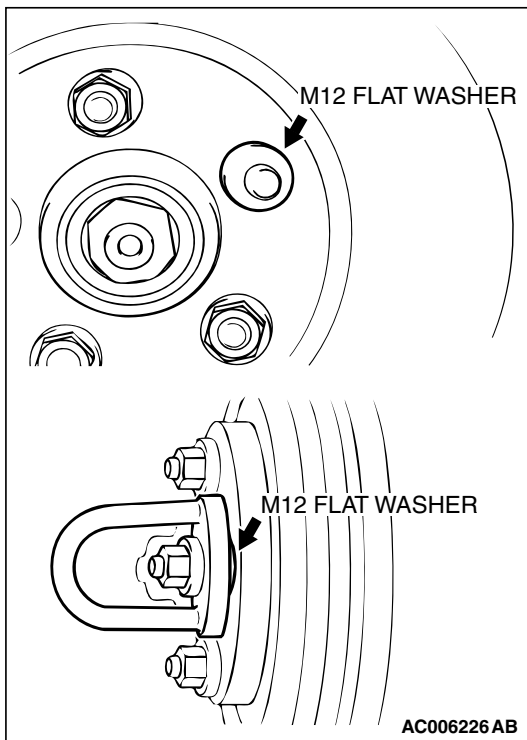
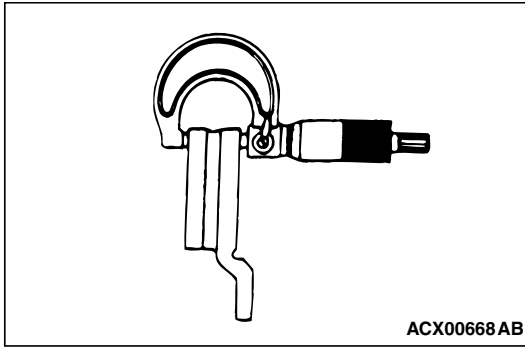

**BRAKE DISC RUN-OUT CHECK AND  
CORRECTION**

1. Remove the brake assembly, and then hold it with wire.
2. Temporarily install the disc with the hub nut.
3. Place a dial gauge approximately 5 mm (0.2 inch) from the outer circumference of the brake disc, and measure the run-out of the disc.

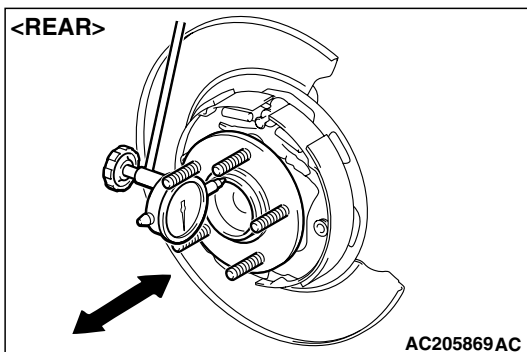
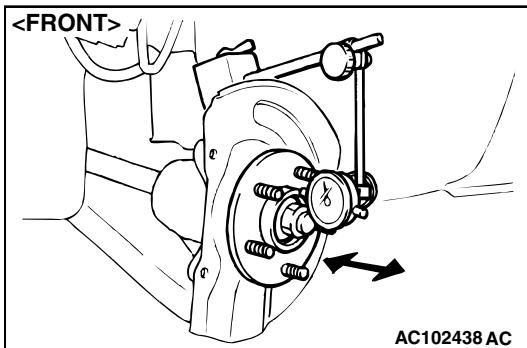
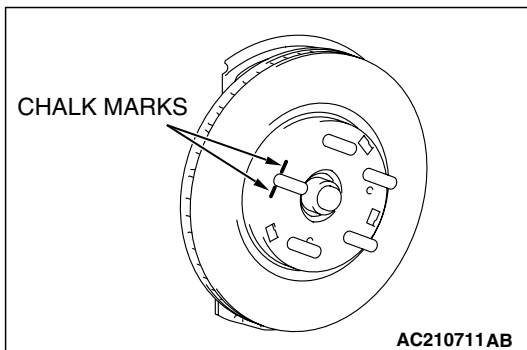
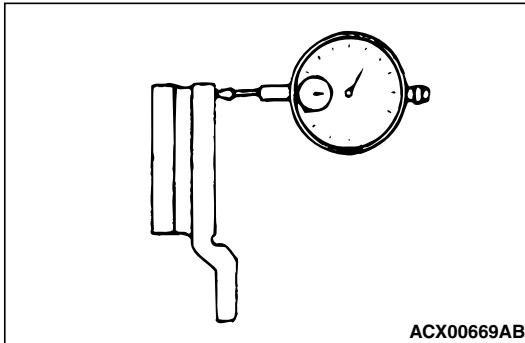
**Limit:****<Front brake disc>: 0.10 mm (0.0039 inch)****<Rear brake disc>: 0.04 mm (0.0016 inch)**

4. If the brake disc run-out exceeds the limit, correct it as follows:
  - (1) Chalk phase marks on the wheel stud and the brake disc as shown.

- (2) Remove the brake disc. Then place a dial gauge as shown, and measure the end play while moving the hub in the axial direction.

**Limit: 0.05 mm (0.002 inch)**

- (3) If the end play exceeds the limit, replace the hub assembly.
- (4) If the end play does not exceed the limit, dephase the brake disc and secure it. Then recheck the brake disc run-out.

**⚠ CAUTION**

- After a new brake disc is installed, always grind the brake disc with an on-the-car type brake lathe. If this step is not carried out, the brake disc run-out exceeds the specified value, resulting in judder.
  - When the on-the-car type lathe is used, first install a M12 flat washer on the stud bolt in the brake disc side according to the figure, and then install the adapter. If the adapter is installed with M12 flat washer not seated, the brake disc rotor may be deformed, resulting in inaccurate grinding.
  - Grind the brake disc with all wheel nuts diagonally and equally tightened to the specified torque 100 N·m (74 ft-lb). If all of the wheel nuts are not used, or the tightening torque is excessive or not equal, the brake disc rotor or drum may be deformed, resulting in judder.
5. If the run-out cannot be corrected by changing the phase of the brake disc, replace the brake disc or grind it with the on-the-car type brake lathe ("MAD, DL-8700PF" or equivalent).

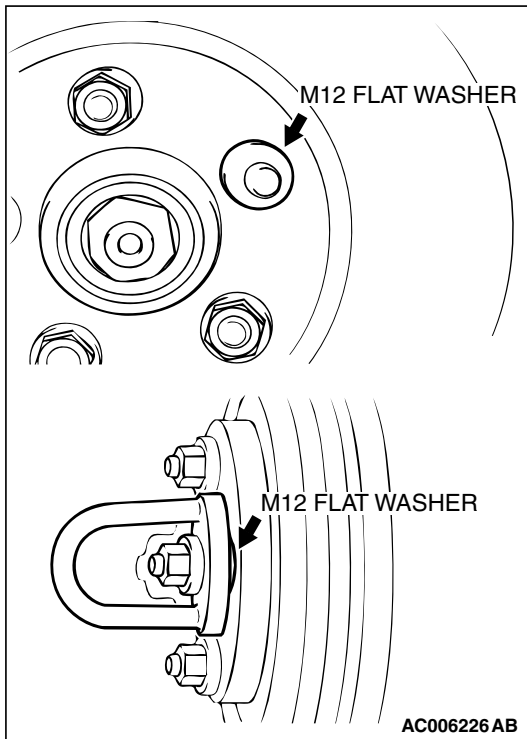

**MASTER CYLINDER FUNCTION CHECK**

M1351010200266

1. Remove the reservoir cap.
2. While watching the open reservoir from a distance of 50 cm (20 inches), have an assistant depress the brake pedal. If there was a stream of brake fluid rising from the reservoir, proceed to Step 3. If there was no stream of brake fluid rising from the reservoir, repair or replace the master cylinder.
3. While watching the open reservoir from a distance of 50 cm (20 inches), have the assistant release the brake pedal. If there was a small amount of air bubbles rising through the brake fluid, master cylinder function is normal. If there were no bubbles rising through the brake fluid, repair or replace the master cylinder.

**BRAKE PEDAL****REMOVAL AND INSTALLATION**

M1351003400406

**Post-installation Operation**

- Brake Pedal Adjustment (Refer to P.35A-13).

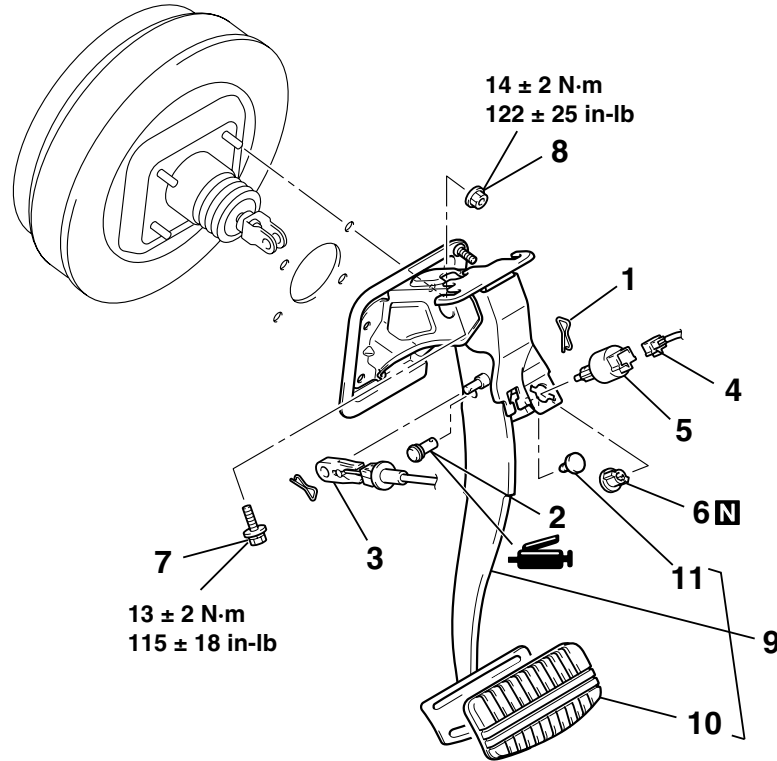

AC206452AB

**REMOVAL STEPS**

1. BRAKE BOOSTER PIN
2. BRAKE BOOSTER PIN ASSEMBLY
3. SHIFT LOCK CABLE CONNECTION
4. STOPLIGHT SWITCH CONNECTOR
5. STOPLIGHT SWITCH
6. BRAKE PEDAL CLIP

**REMOVAL STEPS (Continued)**

- WIRING HARNESSSES CLAMPED ON BRAKE PEDAL ASSEMBLY
- 7. BRAKE PEDAL BOLT
- 8. BRAKE BOOSTER NUT
- 9. BRAKE PEDAL ASSEMBLY
- 10. BRAKE PEDAL PAD
- 11. BRAKE PEDAL STOPPER



INSPECTION

M1351003500221

STOPLIGHT SWITCH CHECK

1. Connect an ohmmeter between the stoplight switch connector terminals.
2. There should be no continuity between the terminals when the plunger is pushed in as shown. There should be continuity when it is released.

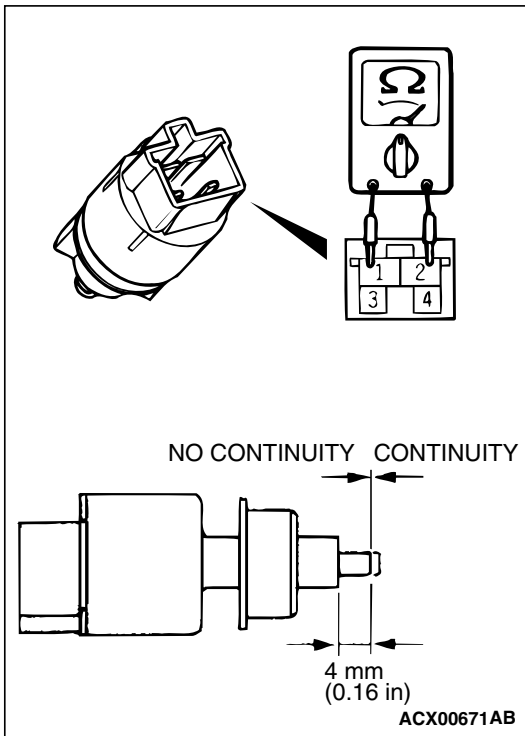

TESTER CONNECTION	PLUNGER	SPECIFIED CONDITION
1 - 2	IN	Open circuit
	OUT	Less than 2Ω

# MASTER CYLINDER ASSEMBLY AND BRAKE BOOSTER REMOVAL AND INSTALLATION

M1351003700407

<p><b>Pre-removal Operation</b></p> <ul style="list-style-type: none"> <li>• Strut Tower Bar Removal (Refer to GROUP 42, Strut Tower Bar P.42-12).</li> <li>• Battery Removal</li> <li>• Brake Fluid Draining</li> </ul>	<p><b>Post-installation Operation</b></p> <ul style="list-style-type: none"> <li>• Brake Fluid Supplying and Air Bleeding (Refer to P.35A-16).</li> <li>• Brake Pedal Adjustment (Refer to P.35A-13).</li> <li>• Battery Installation</li> <li>• Strut Tower Bar Installation (Refer to GROUP 42, Strut Tower Bar P.42-12).</li> </ul>
--	--

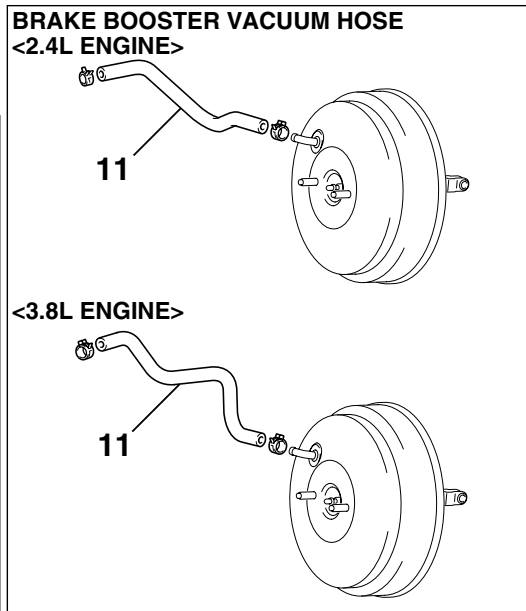
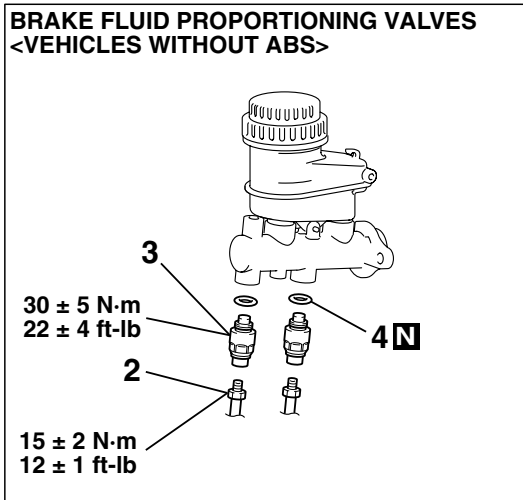
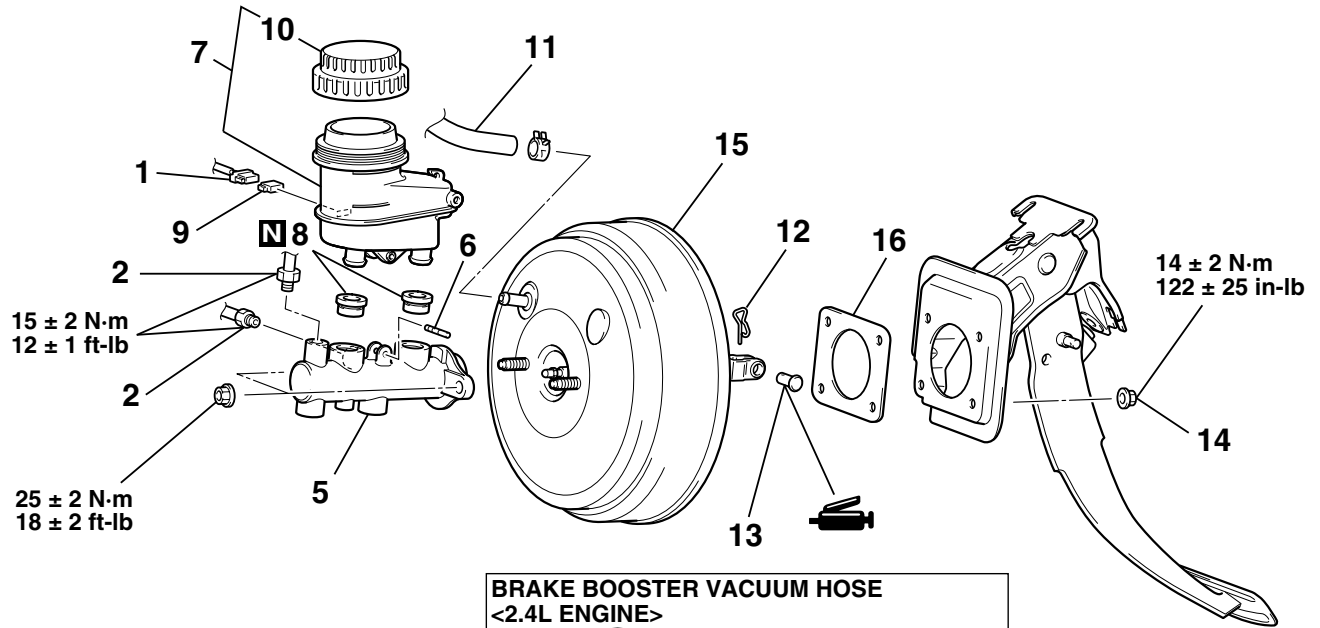

AC306424AB

**BRAKE MASTER CYLINDER  
 ASSEMBLY AND BRAKE FLUID  
 PROPORTIONING VALVE  
 REMOVAL STEPS**

1. BRAKE FLUID LEVEL INDICATOR SWITCH CONNECTOR
2. BRAKE TUBE CONNECTION

**BRAKE MASTER CYLINDER  
 ASSEMBLY AND BRAKE FLUID  
 PROPORTIONING VALVE  
 REMOVAL STEPS (Continued)**

3. BRAKE FLUID PROPORTIONING VALVE <VEHICLES WITHOUT ABS>
4. O-RING

**BRAKE MASTER CYLINDER  
ASSEMBLY AND BRAKE FLUID  
PROPORTIONING VALVE  
REMOVAL STEPS (Continued)**

5. BRAKE MASTER CYLINDER ASSEMBLY
6. SPRING PIN
7. BRAKE FLUID RESERVOIR ASSEMBLY
8. MASTER CYLINDER FLUID RESERVOIR SEAL
9. BRAKE FLUID LEVEL INDICATOR SWITCH
10. BRAKE FLUID RESERVOIR CAP

**BRAKE BOOSTER VACUUM  
HOSE REMOVAL STEP**

- >>A<<** 11. BRAKE BOOSTER VACUUM HOSE (WITH BUILT-IN CHECK VALVE)

**BRAKE BOOSTER ASSEMBLY  
REMOVAL STEPS**

1. BRAKE FLUID LEVEL INDICATOR SWITCH CONNECTOR
2. BRAKE TUBE CONNECTION

**BRAKE BOOSTER ASSEMBLY  
REMOVAL STEPS (Continued)**

5. BRAKE MASTER CYLINDER ASSEMBLY
- >>B<<** • PUSH ROD PROTRUSION AMOUNT CHECK AND ADJUSTMENT
- >>A<<** 11. BRAKE BOOSTER VACUUM HOSE
12. BRAKE BOOSTER PIN
13. BRAKE BOOSTER PIN ASSEMBLY
14. BRAKE BOOSTER NUT
15. BRAKE BOOSTER ASSEMBLY
16. BRAKE BOOSTER BODY SEAL

**Required Special Tool:**

- MB991568: Push Rod Adjusting Socket

**INSTALLATION SERVICE POINTS**

**>>A<< BRAKE BOOSTER VACUUM HOSE CONNECTION**

Insert vacuum hose with its paint mark facing upward.

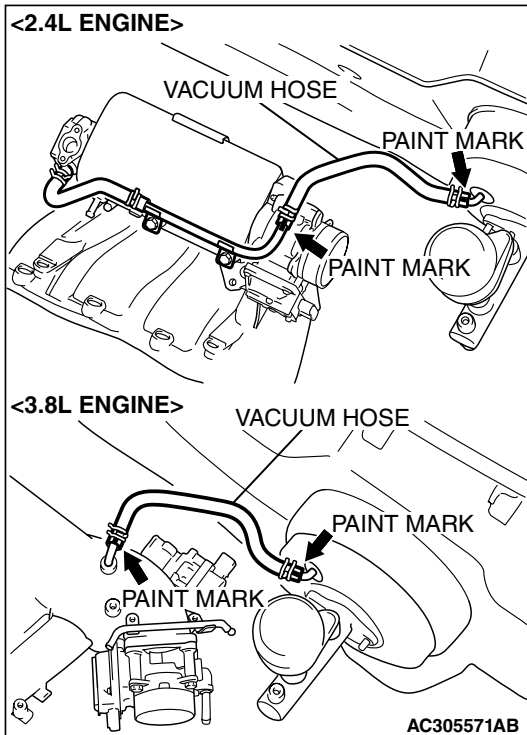

**>>B<< PUSH ROD PROTRUSION AMOUNT  
CHECK AND ADJUSTMENT**

1. Use the vacuum pump to measure dimension "A" applying a negative pressure of 66.7 kPa (19.7 inHg) to the brake booster.

**Standard value (A): 10.28 – 10.52 mm (0.405 – 0.414 inch)**

*NOTE: When a negative pressure of 66.7 kPa (19.7 inHg) is not applied to the brake booster, the push rod protrusion amount (A) should be 8.78 - 9.02 mm (0.346 – 0.355 inch).*

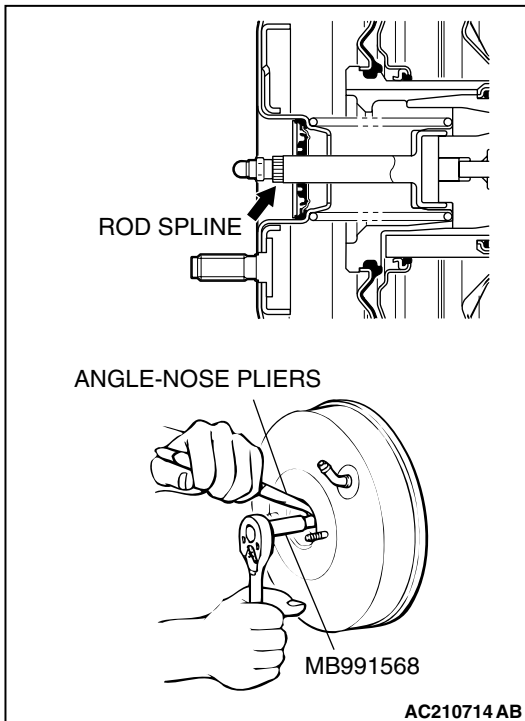
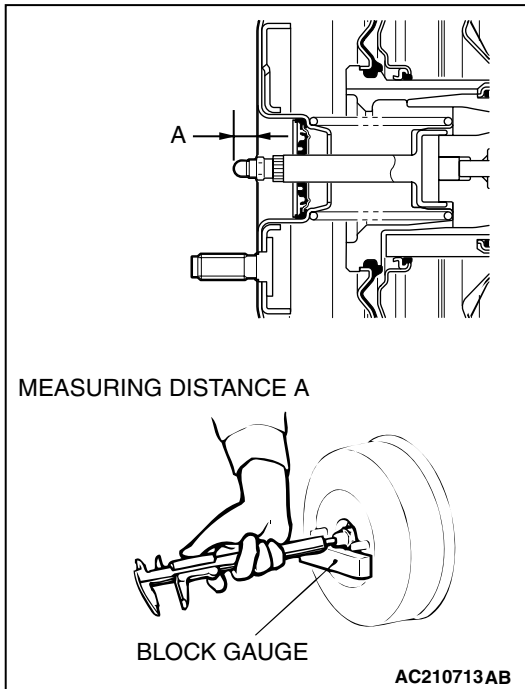

2. If the protrusion amount is not within the standard value range, adjust the push rod length by turning the push rod. Use special tool MB991568 to turn the push rod while holding the rod spline with angle-nose pliers.

**MASTER CYLINDER  
 DISASSEMBLY AND ASSEMBLY**

M1351004200375

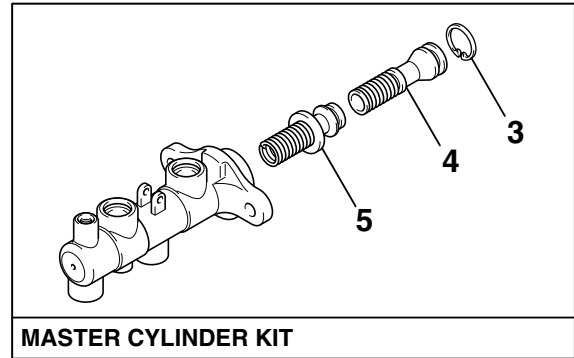
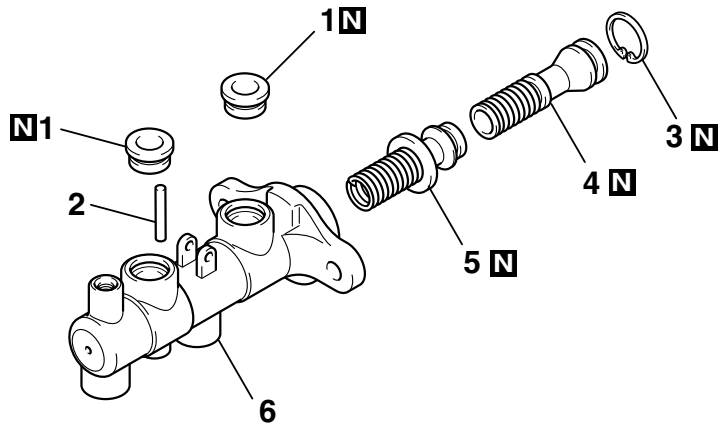

MASTER CYLINDER KIT

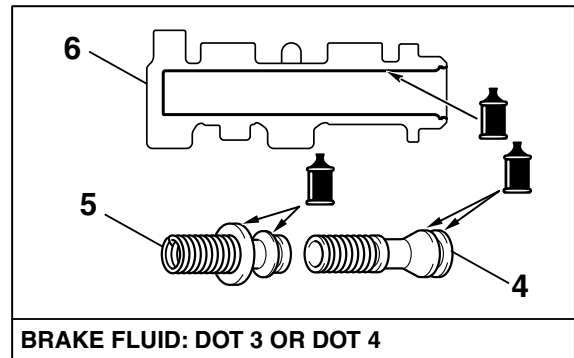

BRAKE FLUID: DOT 3 OR DOT 4

AC306545AB

**DISASSEMBLY STEPS**

1. BRAKE MASTER CYLINDER TO FLUID RESERVOIR SEAL
2. BRAKE MASTER CYLINDER PIN <VEHICLES WITH ABS>

<<A>>

**DISASSEMBLY STEPS**

3. BRAKE MASTER CYLINDER UNION RETAINER
4. PRIMARY PISTON ASSEMBLY
5. SECONDARY PISTON ASSEMBLY
6. MASTER CYLINDER BODY

**DISASSEMBLY SERVICE POINT**

**<<A>> BRAKE MASTER CYLINDER UNION RETAINER DISASSEMBLY**

Remove the brake master cylinder union retainer while depressing the piston.

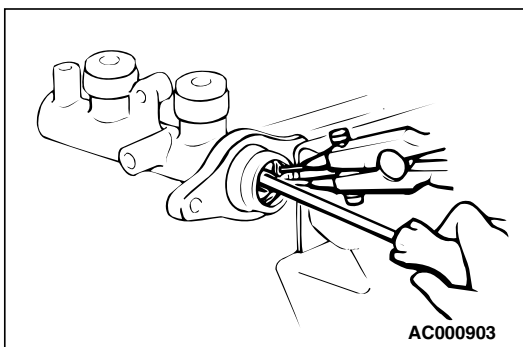

AC000903

**INSPECTION**

- Check the inner surface of master cylinder body for rust or pitting.
- Check the primary and secondary pistons for rust, scoring, wear or damage.

M1351004300297

# DISC BRAKE ASSEMBLY

## REMOVAL AND INSTALLATION

M1351008000050

<p><b>Pre-removal Operation</b></p> <ul style="list-style-type: none"> <li>• Brake Fluid Draining</li> </ul>	<p><b>Post-installation Operation</b></p> <ul style="list-style-type: none"> <li>• Brake Fluid Supplying and Air Bleeding (Refer to P.35A-16).</li> </ul>
--	---

<FRONT>

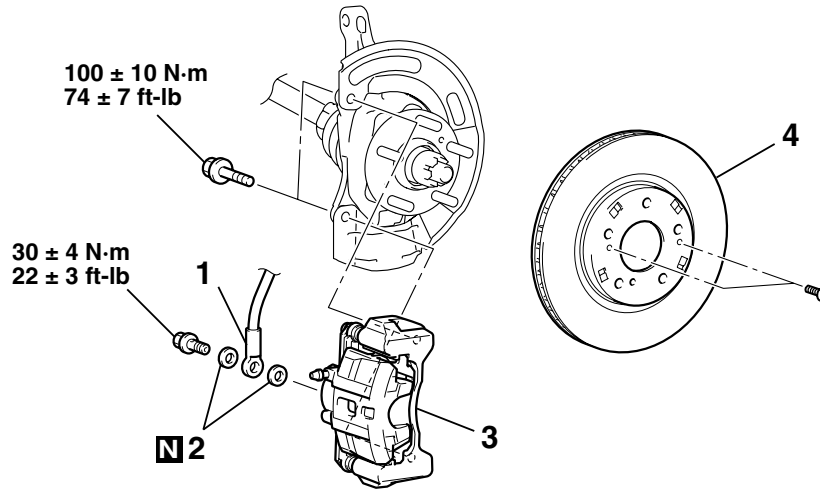

AC305577AB

<REAR>

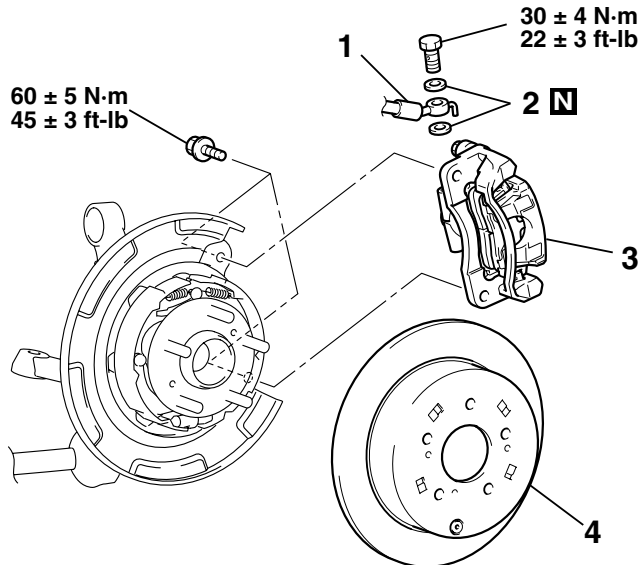

AC305578AB

**REMOVAL STEPS**

- BRAKE FLUID DRAINING
- 1. BRAKE HOSE CONNECTION
- 2. GASKET
- 3. BRAKE CALIPER ASSEMBLY
- 4. BRAKE DISC

**INSTALLATION STEPS**

- BRAKE FLUID DRAINING
- 4. BRAKE DISC
- 3. BRAKE CALIPER ASSEMBLY
- 2. GASKET

**INSTALLATION STEPS (Continued)**

- 1. BRAKE HOSE CONNECTION
- BRAKE FLUID SUPPLYING AND AIR BLEEDING (Refer to P.35A-16.)
- >>A<< • BRAKE DRAG FORCE CHECK

**Required Special Tool:**

- MB990520: Disc Brake Piston Expander

INSTALLATION SERVICE POINT

>>A<< BRAKE DRAG FORCE CHECK

1. In order to measure the brake drag force, measure the hub torque with the pads removed by the following procedure.  
Use a spring scale to measure the hub torque in the forward direction. Record hub torque with pads removed.

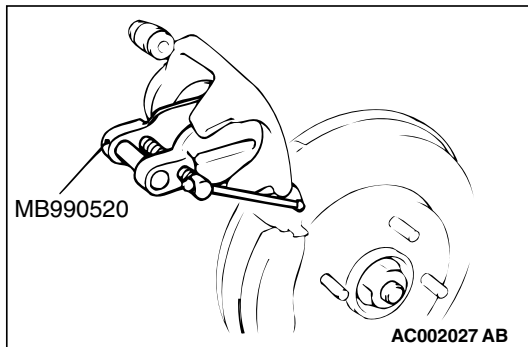
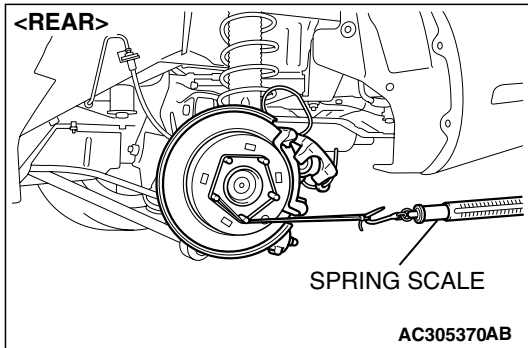
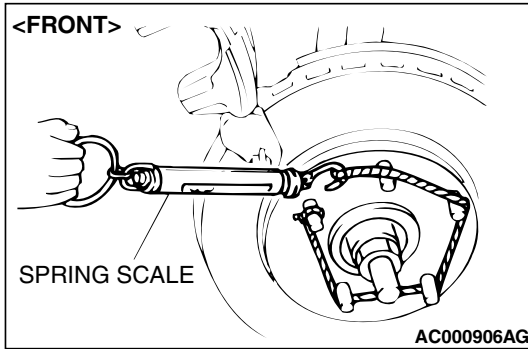

**⚠ CAUTION**

**Do not let any oil, grease or other contamination get onto the friction surfaces of the pads and brake discs.**

2. After re-installing the caliper support to the knuckle, install the pad clips and the pads to the caliper support.
3. Clean the piston and insert into cylinder with special tool MB990520.
4. Be careful that the piston boot does not become caught, when lowering the caliper assembly and installing the lock pin bolt.
5. Check the brake drag force as follows.
  - (1) Start the engine and hold the brake pedal down for 5 seconds. [Pedal depression force: approximately 200 N (45 pound)]
  - (2) Stop the engine.
  - (3) Turn the brake disc forward 10 times.

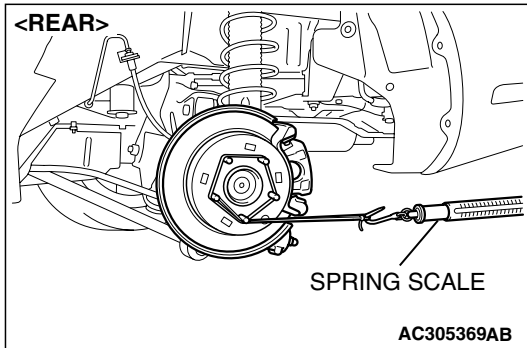
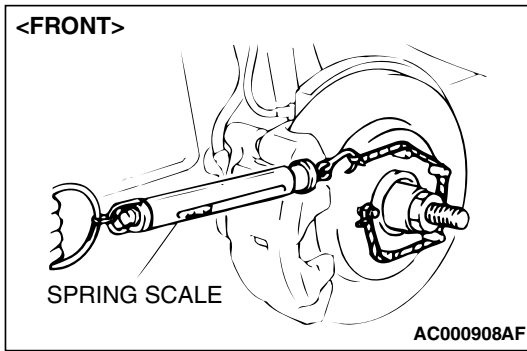

- (4) Use a spring scale to measure the hub torque with pads installed in the same direction as earlier.
- (5) Calculate the drag force of the disc brake [difference between hub torque with pads installed and hub torque with pads removed].

**Standard value:**

<Front-2.4L engine> 54 N (12 pounds) or less

<Front-3.8L engine> 64 N (14 pounds) or less

<Rear> 54 N (12 pounds) or less

6. If the brake drag force exceeds the standard value, disassemble and clean the piston. Check for corrosion or worn piston seal, and check the sliding condition of the lock pin and guide pin.

## INSPECTION

M1351008100046

### BRAKE DISC CHECK

- Disc wear (Refer to [P.35A-20](#)).
- Disc run-out (Refer to [P.35A-20](#)).



DISASSEMBLY AND ASSEMBLY <FRONT>

M1351008200065

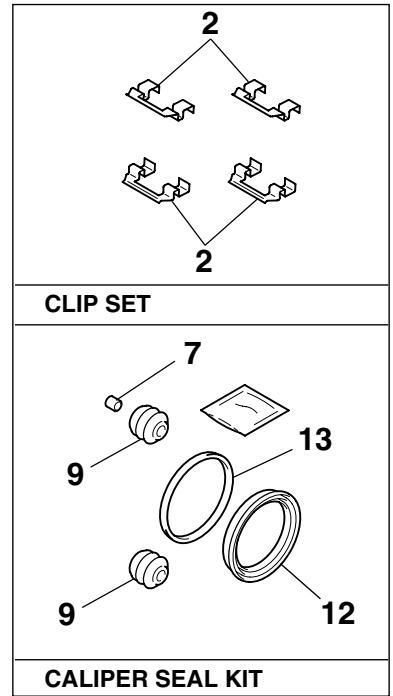
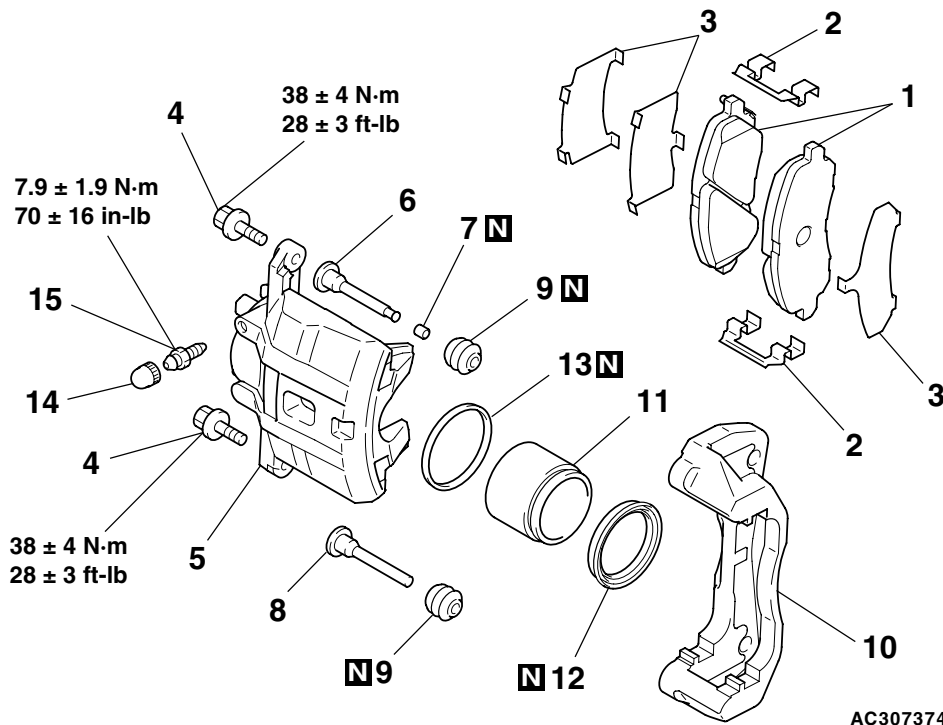

AC307374AB

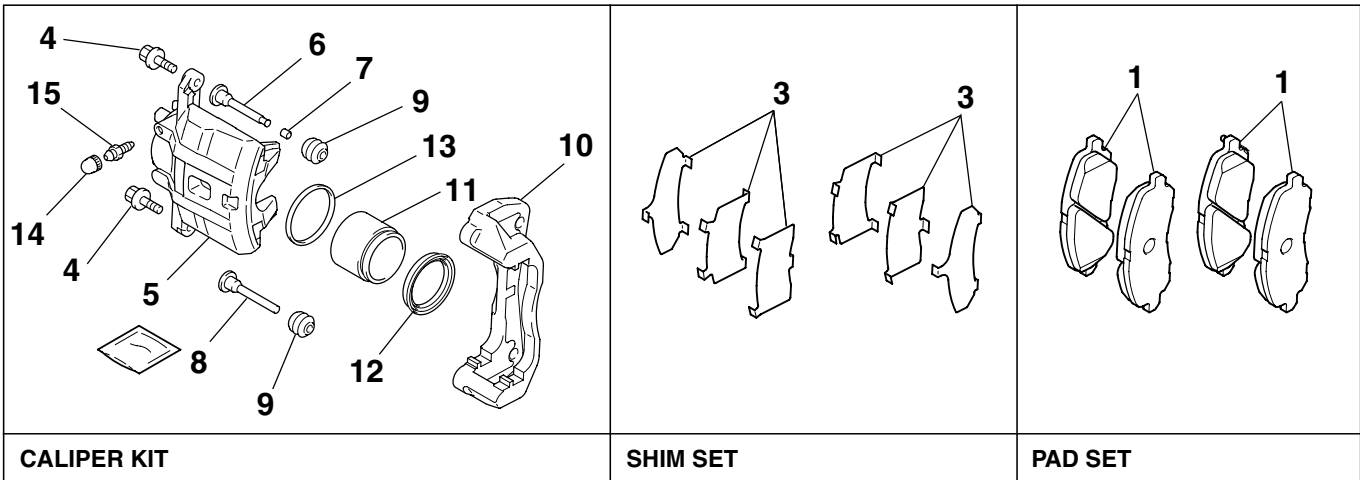

- DISASSEMBLY STEPS**
1. PAD (AND WEAR INDICATOR) ASSEMBLY
  2. CLIP
  3. SHIM
  4. FRONT BRAKE BOLT
  5. CALIPER BODY
  6. LOCK PIN
  7. BUSH

<<A>>  
<<A>>  
<<B>>

- DISASSEMBLY STEPS (Continued)**
8. GUIDE PIN
  9. BOOT
  10. CALIPER SUPPORT
  11. CALIPER PISTON
  12. PISTON BOOT
  13. PISTON SEAL
  14. CALIPER BLEEDER CAP
  15. CALIPER BLEEDER

LUBRICATION POINTS

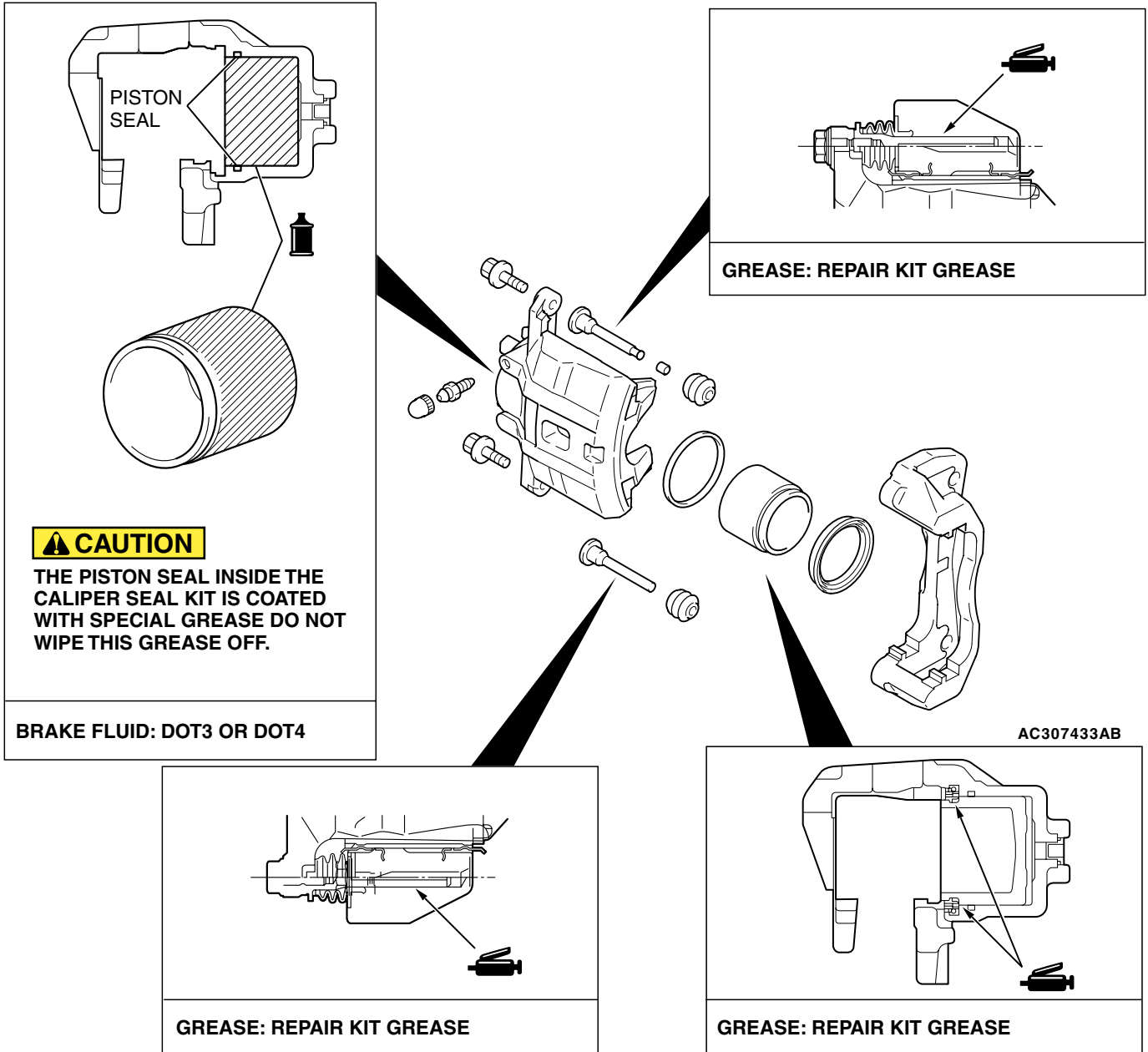

**CAUTION**

THE PISTON SEAL INSIDE THE CALIPER SEAL KIT IS COATED WITH SPECIAL GREASE DO NOT WIPE THIS GREASE OFF.

DISASSEMBLY SERVICE POINTS

**CAUTION**

When disassembling the front disc brakes, disassemble both sides (left and right wheels) as a set.

## <<A>> CALIPER PISTON/PISTON BOOT REMOVAL

### CAUTION

Blow air little by little to remove the piston. The piston will pop out if a force of air is applied suddenly.

Place a piece of wood, etc. against the caliper body as shown. Blow compressed air through the brake hose connection hole to remove the piston boot and piston.

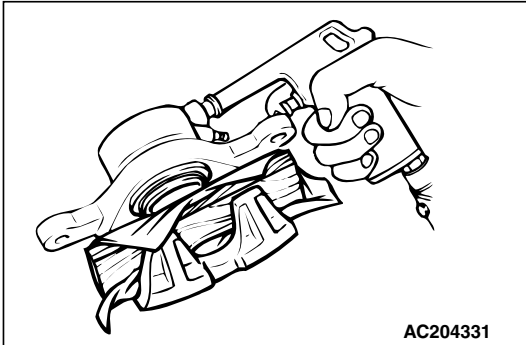

## <<B>> PISTON SEAL REMOVAL

### CAUTION

Do not use a flat-tipped screwdriver or similar tool to remove the piston seal. These may damage the inner side of the cylinder.

1. Remove the piston seal with your finger tip.
2. Clean the piston surface and inner cylinder with alcohol brake fluid DOT 3 or DOT 4.

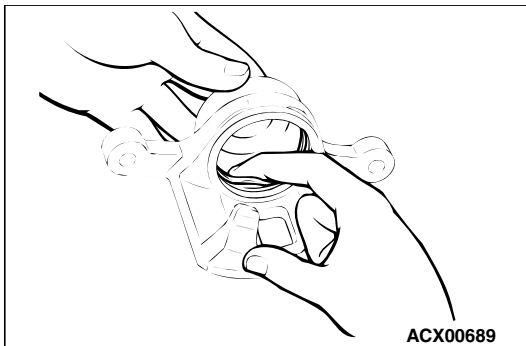

DISASSEMBLY AND ASSEMBLY <REAR>

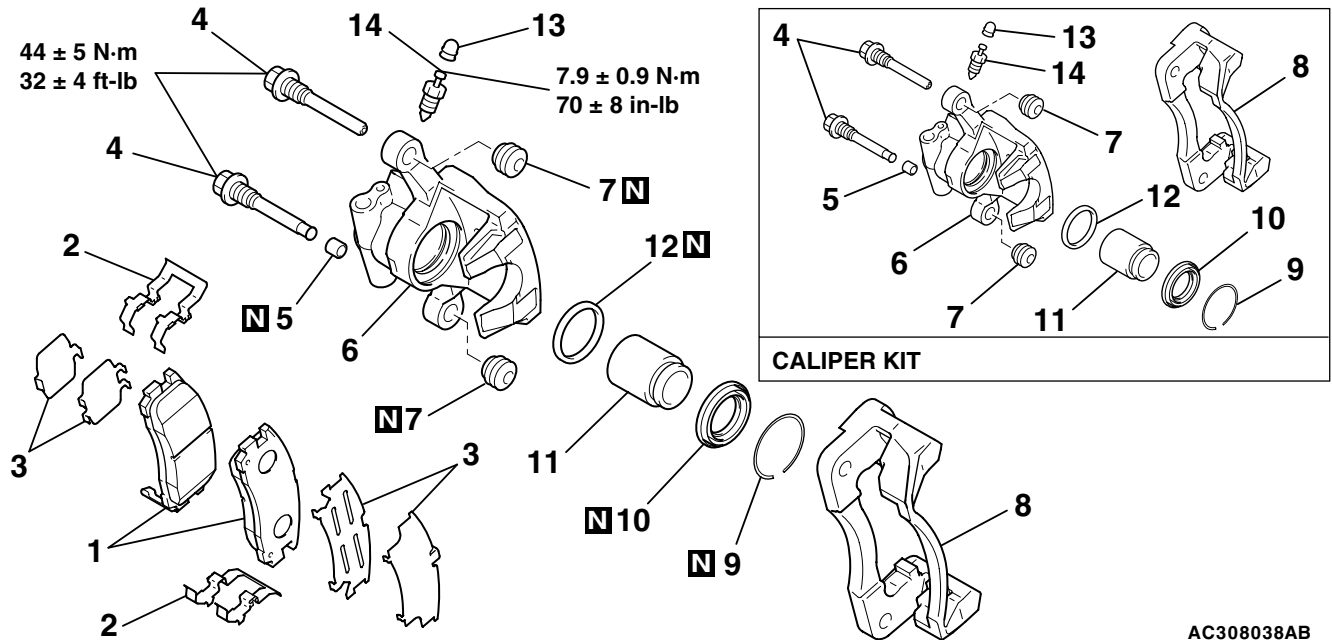

AC308038AB

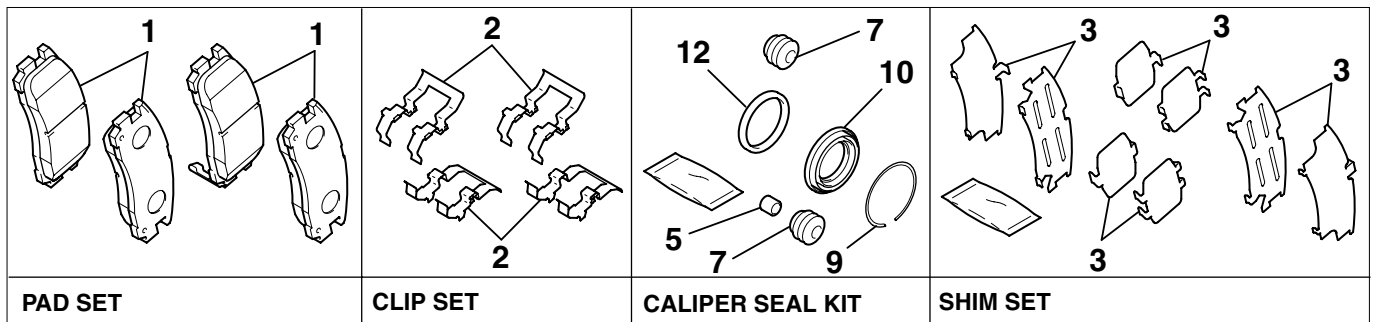

DISASSEMBLY STEPS

1. PAD (AND WEAR INDICATOR) ASSEMBLY
2. CLIP
3. SHIM
- >>A<< 4. REAR BRAKE PIN
5. REAR BRAKE BUSHING
6. CALIPER BODY
7. PIN BOOT

<<A>>  
<<A>>  
<<B>>

DISASSEMBLY STEPS (Continued)

8. CALIPER SUPPORT
9. BOOT RING
10. PISTON BOOT
11. CALIPER PISTON
12. PISTON SEAL
13. REAR BRAKE CAP
14. CALIPER BLEEDER

LUBRICATION POINTS

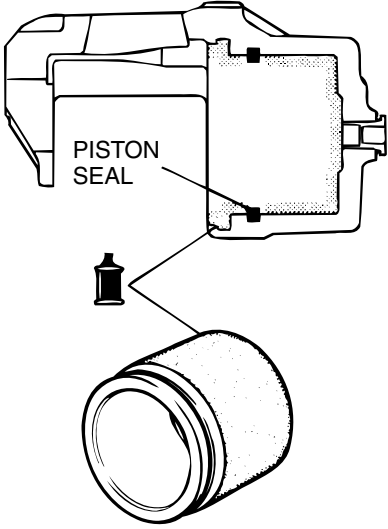

PISTON SEAL

**CAUTION**  
THE PISTON SEAL INSIDE THE CALIPER SEAL KIT IS COATED WITH SPECIAL GREASE. DO NOT WIPE THIS GREASE OFF.

BRAKE FLUID: DOT3 OR DOT4

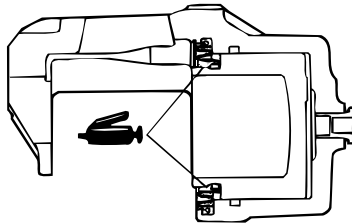

GREASE: REPAIR KIT GREASE

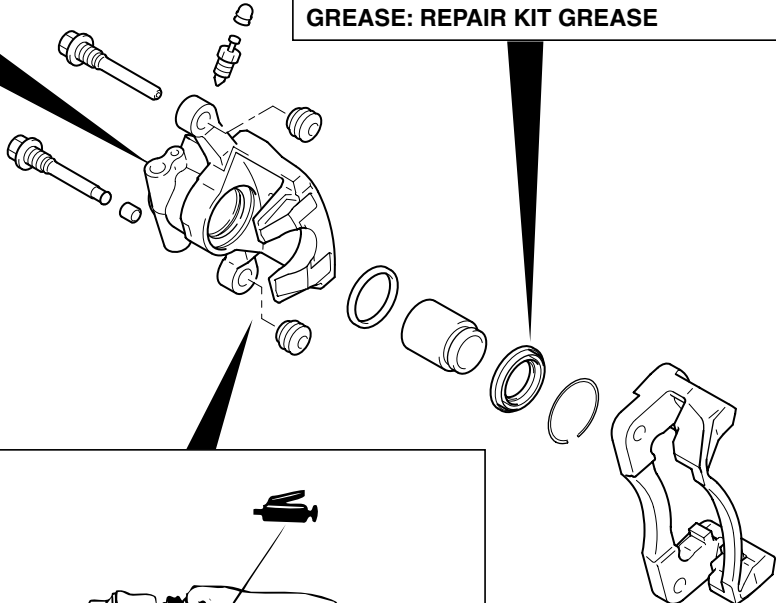

GREASE: REPAIR KIT GREASE

AC308045AB

DISASSEMBLY SERVICE POINTS

**CAUTION**

When disassembling the disc brakes, disassemble both sides (left and right) as a set.

**<<A>> PISTON BOOT/CALIPER PISTON  
REMOVAL****⚠ CAUTION**

Blow air little by little to remove the piston. The piston will pop out if a force of air is applied suddenly.

Place a piece of wood, etc. against the caliper body as shown. Blow compressed air through the brake hose connection hole to remove the piston boot and piston.

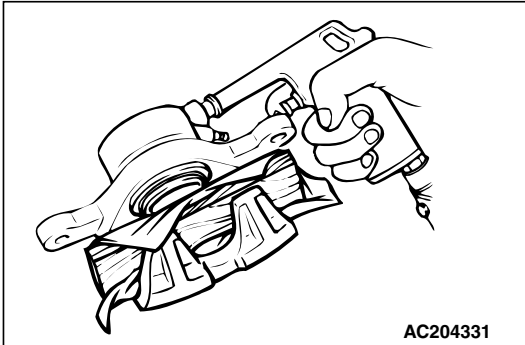

AC204331

**<<B>> PISTON SEAL REMOVAL****⚠ CAUTION**

Do not use a flat-tipped screwdriver or similar tool to remove piston seal. These may damage the inner side of the cylinder.

1. Remove the piston seal with your finger tip.
2. Clean piston surface and inner cylinder with alcohol or brake fluid DOT 3 or DOT 4.

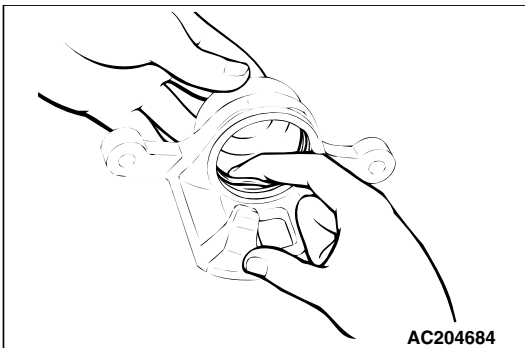

AC204684

**ASSEMBLY SERVICE POINT****>>A<< REAR BRAKE PIN INSTALLATION**

Attach a guide pin (with "g" on the bolt head) at the bleeder nipple side of the caliper body and a lock pin (with "l" on the bolt head) at the opposite side.

**INSPECTION**

M1351008300039

- Check the cylinder for wear, damage or rust.
- Check the piston surface for wear, damage or rust.
- Check the caliper body or sleeve for wear.
- Check the pad for damage or adhesion of grease, check the backing metal for damage.

## PAD WEAR CHECK

**⚠ WARNING**

- *Always replace both brake pads on each wheel as a set (both front wheels or both rear wheels). Failure to do so will result in uneven braking, which may cause unreliable brake operation.*
- *If there is significant difference in the thickness of the pads on the left and right sides, check the sliding condition of the piston and slide pins.*

1. Measure thickness at the thinnest and most worn area of the pad.

**Standard value: 10 mm (0.39 inch)**

**Minimum limit: 2.0 mm (0.08 inch)**

2. Replace the pad assembly if pad thickness is less than the limit value.

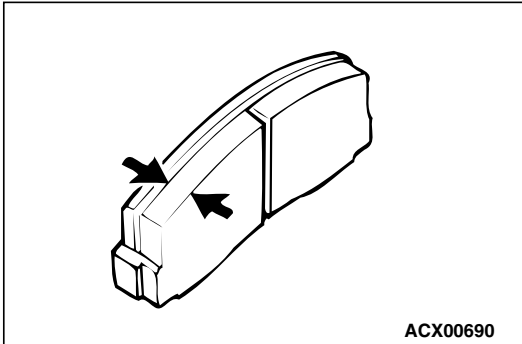

ACX00690

## SPECIFICATIONS

## FASTENER TIGHTENING SPECIFICATIONS

M1351009600390

ITEM	SPECIFICATION
<b>Brake line</b>	
Brake tube flare nut	15 ± 2 N·m (12 ± 1 ft-lb)
<b>Brake pedal</b>	
Brake booster nut	14 ± 2 N·m (122 ± 25 in-lb)
Brake pedal bolt	13 ± 2 N·m (115 ± 18 in-lb)
<b>Front disc brake</b>	
Brake hose connector bolt	30 ± 4 N·m (22 ± 3 ft-lb)
Caliper bleeder	7.9 ± 1.9 N·m (70 ± 16 in-lb)
Front brake assembly mounting bolt	100 ± 10 N·m (74 ± 7 ft-lb)
Front brake bolt (guide pin bolt)	38 ± 4 N·m (28 ± 3 ft-lb)
Front brake bolt (lock pin bolt)	38 ± 4 N·m (28 ± 3 ft-lb)
<b>Master cylinder assembly and brake booster</b>	
Brake booster nut	14 ± 2 N·m (122 ± 25 in-lb)
Brake fluid proportioning valve <Vehicles without ABS>	30 ± 5 N·m (22 ± 4 ft-lb)
Brake master cylinder mounting nut	25 ± 2 N·m (18 ± 2 ft-lb)
<b>Rear disc brake</b>	
Brake hose connector bolt	30 ± 4 N·m (22 ± 3 ft-lb)
Caliper bleeder	7.9 ± 0.9 N·m (70 ± 8 in-lb)
Rear brake assembly mounting bolt	60 ± 5 N·m (45 ± 3 ft-lb)
Rear brake pin (guide pin bolt)	44 ± 5 N·m (32 ± 4 ft-lb)
Rear brake pin (lock pin bolt)	44 ± 5 N·m (32 ± 4 ft-lb)

## GENERAL SPECIFICATIONS

M1351000200362

ITEM	SPECIFICATION	
Master cylinder	Type	Tandem type
	I.D. mm (in)	25.4 (1.0)
Brake booster	Type	Vacuum type, tandem
	Effective dia. of power cylinder mm (in)	205 + 230 (8 + 9)
	Boosting ratio	6.5
Rear wheel hydraulic control method	Electronic brake-force distribution (EBD) <Vehicles with ABS> Proportioning valves <Vehicles without ABS>	
Front brakes	Type	Floating caliper, 1 piston, ventilated disc
	Disc effective dia × thickness mm (in)	222 × 26.0 (8.7 × 1.02) <2.4L engine> 241 × 26.0 (9.5 × 1.02) <3.8L engine>
	Wheel cylinder I.D. mm (in)	60.33 (2.38)
	Pad thickness mm (in)	10.0 (0.39)
	Clearance adjustment	Automatic



**BASIC BRAKE SYSTEM  
SPECIFICATIONS**

**35A-41**

ITEM		SPECIFICATION
Rear brakes	Type	Floating caliper, 1 piston, solid disc
	Disc effective dia × thickness mm (in)	222 × 10 (8.7 × 0.39)
	Wheel cylinder I.D. mm (in)	34.9 (1.38)
	Pad thickness mm (in)	10.0 (0.39)
	Clearance adjustment	Automatic

**SERVICE SPECIFICATIONS**

M1351000300477

ITEM		STANDARD VALUE	LIMIT
Brake pedal height mm (in)		169.8 – 172.8 (6.69 – 6.80)	–
Brake pedal free play mm (in)		3 – 8 (0.12 – 0.31)	–
Brake pedal to floor board clearance mm (in)		110 (4.33) or more	–
Proportioning valve output fluid pressure MPa (psi) <Vehicles without ABS>	Split point	3.68 – 4.17 (534 – 605)	–
	When input fluid pressure is 7.85 MPa (1,139 psi).	5.24 – 5.74 (760 – 833)	–
Proportioning valve output fluid pressure difference between left and right MPa (psi)		–	0.5 (73)
Disc brake pad thickness mm (in)		10.0 (0.39)	Minimum 2.0 (0.08)
Disc brake disc thickness mm (in)	Front	26.0 (1.02)	Minimum 24.4 (0.96)
	Rear	10.0 (0.39)	Minimum 8.4 (0.33)
Disc brake disc run-out mm (in)	Front	–	0.1 (0.0039)
	Rear	–	0.04 (0.0016)
Disc brake drag force N (lb)	Front–2.4L engine	54 (12) or less	–
	Front–3.8L engine	64 (14) or less	–
	Rear	54 (12) or less	–
Hub end play mm (in)		–	0.05 (0.002)
Brake booster push rod protruding length mm (in) [When applying negative pressure of 66.7 kPa (19.7 inHg) to the brake booster]		10.28 – 10.52 (0.405 – 0.414)	–

**LUBRICANTS**

M1351000400429

ITEM	SPECIFIED LUBRICANT
Brake fluid	DOT3 or DOT4
Piston boot, piston seal	Repair kit grease
Front brake pin, rear brake pin (guide pin, lock pin)	

---

## NOTES