

GROUP 27

REAR AXLE

CONTENTS

GENERAL DESCRIPTION	27-2	HUB BOLT REPLACEMENT	27-5
REAR AXLE DIAGNOSIS	27-2	REAR AXLE HUB ASSEMBLY	27-6
INTRODUCTION TO REAR AXLE DIAGNOSIS	27-2	REMOVAL AND INSTALLATION	27-6
REAR AXLE DIAGNOSTIC TROUBLESHOOTING STRATEGY	27-2	INSPECTION	27-7
SYMPTOM PROCEDURES	27-3	KNUCKLE	27-8
SPECIAL TOOLS	27-4	REMOVAL AND INSTALLATION	27-8
ON-VEHICLE SERVICE	27-4	INSPECTION	27-9
WHEEL BEARING END PLAY CHECK	27-4	SPECIFICATIONS	27-10
REAR HUB ROTARY-SLIDING RESISTANCE CHECK	27-5	FASTENER TIGHTENING SPECIFICATIONS	27-10
		SERVICE SPECIFICATIONS	27-10

GENERAL DESCRIPTION

M1271000100326

The rear axle has the following features:

- The wheel bearing incorporates a unit ball bearing (double-row angular contact ball bearing) for reduced friction.
- The rear wheel hub assembly combines the hub, wheel bearing, and oil seal in a single unit for fewer parts, better durability, improved assembly precision, and better structural organization.
- ABS rotor for detecting the wheel speeds is press-fitted to the rear hub in vehicles with ABS.

CONSTRUCTION DIAGRAM

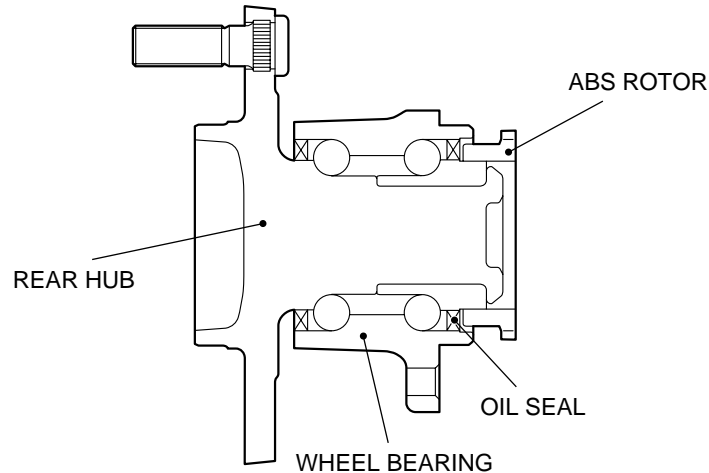

AC305169 AB

REAR AXLE DIAGNOSIS

INTRODUCTION TO REAR AXLE DIAGNOSIS

M1271004100254

Noise from the rear axle may be caused by defects in the components.

REAR AXLE DIAGNOSTIC TROUBLESHOOTING STRATEGY

M1271004200273

Use these steps to plan your diagnostic strategy. If you follow them carefully, you will be sure that you have exhausted most of the possible ways to find a rear axle fault.

1. Gather information from the customer.
2. Verify that the condition described by the customer exists.
3. Find the malfunction by following the Symptom Procedures.
4. Verify malfunction is eliminated.

SYMPTOM PROCEDURES

M1271004400222

INSPECTION PROCEDURE 1: Abnormal Noise

DIAGNOSIS

STEP 1. Check the rear hub assembly installation bolts for looseness.

Q: Are the rear hub assembly installation bolts loosened?

YES : Tighten the rear hub assembly installation bolts to the specified torque 73 ± 7 N·m (54 ± 5 ft·lb). Then go to Step 4.

NO : Go to Step 2.

STEP 2. Check the wheel bearing end play.

- (1) Remove the caliper assembly, and suspend the caliper assembly with a wire and remove the brake disc.
- (2) Check the bearing's end play. Place a dial gauge against the hub surface; then move the hub in the axial direction and check whether or not there is end play.

Limit: 0.05 mm (0.002 inch)

Q: Is the wheel bearing end play within the limit?

YES : Go to Step 3.

NO : Replace the rear hub assembly, then go to Step 4.

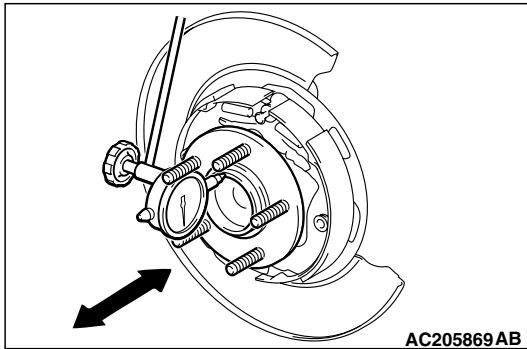

STEP 3. Check the rear hub rotary-sliding resistance.

- (1) Remove the caliper assembly, and suspend the caliper assembly with a wire and remove the brake disc.
- (2) Turn the hub a few times to seat the bearing.
- (3) Wind a rope around the hub bolt and turn the hub by pulling at a 90° angle with a spring balance. Measure to determine whether or not the rotary-sliding resistance of the rear hub is within the limit value.

Limit: 24 N (5.4 lbs)

Q: Is the rear hub rotary-sliding resistance within the limit?

YES : Go to Step 4.

NO : Replace the rear hub assembly, then go to Step 4 .

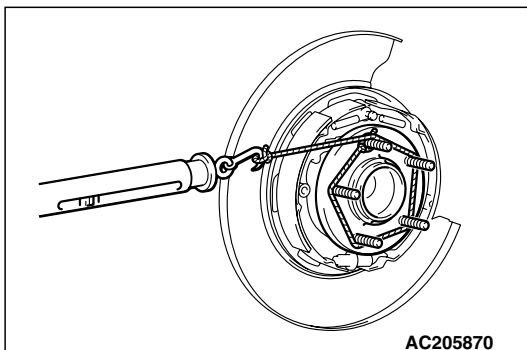

STEP 4. Retest the systems.

Q: Are abnormal noises generated?

YES : Return to Step 1.

NO : The procedure is complete.

SPECIAL TOOLS

M1271000600525

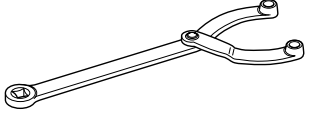
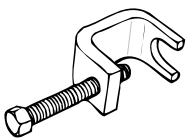
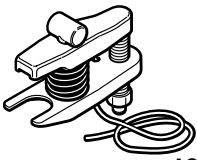
TOOL	TOOL NUMBER AND NAME	SUPERSESION	APPLICATION
 B990767	MB990767 Front hub and flange yoke Holder	MB990767-01	Hub fixing
 MB991618	MB991618 Hub bolt remover	General service tool	Hub bolt removal
 AC106827	MB991897 Ball joint remover	MB991113-1, MB990635-01 or general service tool	Ball joint disconnection <i>NOTE: Steering linkage puller(MB990635 or MB991113)is also used to disconnect knuckle and toe control arm ball joint.</i>

ON-VEHICLE SERVICE

WHEEL BEARING END PLAY CHECK

M1271000900474

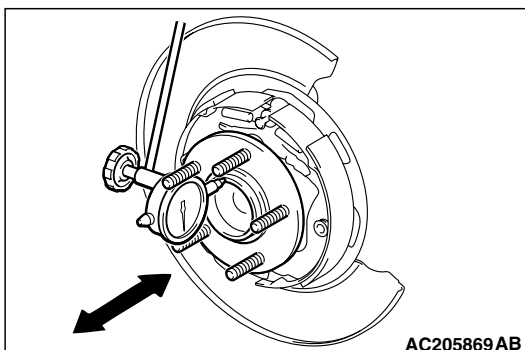

1. Remove the caliper assembly, and suspend the caliper assembly with a wire and remove the brake disc.
2. Check the bearing's end play. Place a dial gauge against the hub surface; then move the hub in the axial direction and check whether or not there is end play.

Limit: 0.05 mm (0.002 inch)

3. If the play exceeds the limit, replace the rear hub assembly.
4. After having finished the inspection, install the brake disc, caliper assembly and tighten the caliper assembly mounting bolts to the specified torque.

Tightening torque: 60 ± 5 N·m (45 ± 3 ft·lb)

REAR HUB ROTARY-SLIDING RESISTANCE CHECK

M1271001100266

1. Remove the caliper assembly, and suspend the caliper assembly with a wire and remove the brake disc.
2. Turn the hub a few times to seat the bearing.
3. Wind a rope around the hub bolt and turn the hub by pulling at a 90 degree angle with a spring balance. Measure to determine whether or not the rotary-sliding resistance of the rear hub is within the limit value.

Limit: 24 N (5.4 pounds)

4. If the rotary-sliding resistance exceeds the limit value, replace the rear hub assembly.
5. After having finished the inspection, install the brake disc, caliper assembly and tighten the caliper assembly mounting bolts to the specified torque.

Tightening torque: 60 ± 5 N·m (45 ± 3 ft-lb)

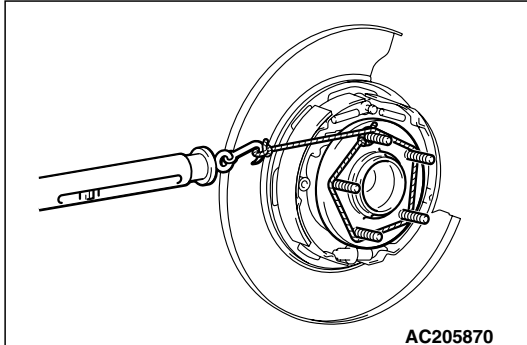

HUB BOLT REPLACEMENT

M1271001000270

Required Special Tools:

- MB990767: Front Hub and Flange Yoke Holder
- MB991618: Hub Bolt Remover

1. Remove the caliper assembly, and suspend the caliper assembly with a wire and remove the brake disc.
2. Use special tool MB991618 to remove the hub bolts.

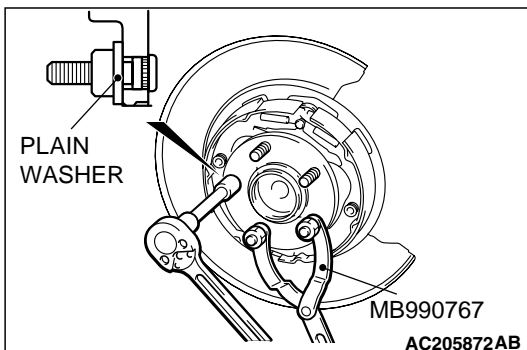
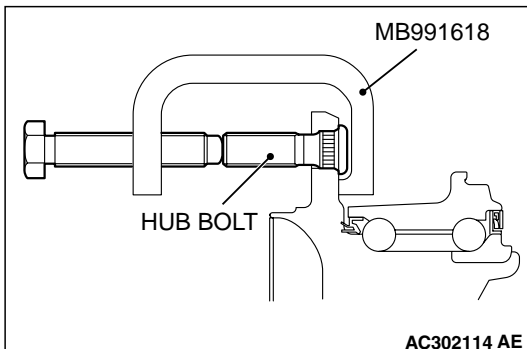

3. Install the plain washer to the new hub bolt, and install the bolt with a nut while holding the hub with special tool MB990767.
4. Install the brake disc, caliper assembly and tighten the caliper assembly mounting bolts to the specified torque.

Tightening torque: 60 ± 5 N·m (45 ± 3 ft-lb)

REAR AXLE HUB ASSEMBLY

REMOVAL AND INSTALLATION

M1271002000411

CAUTION

- For vehicles with ABS, be careful not to strike the pole piece at the tip of the rear wheel speed sensor with tools during servicing work.
- The rear hub assembly should not be dismantled.

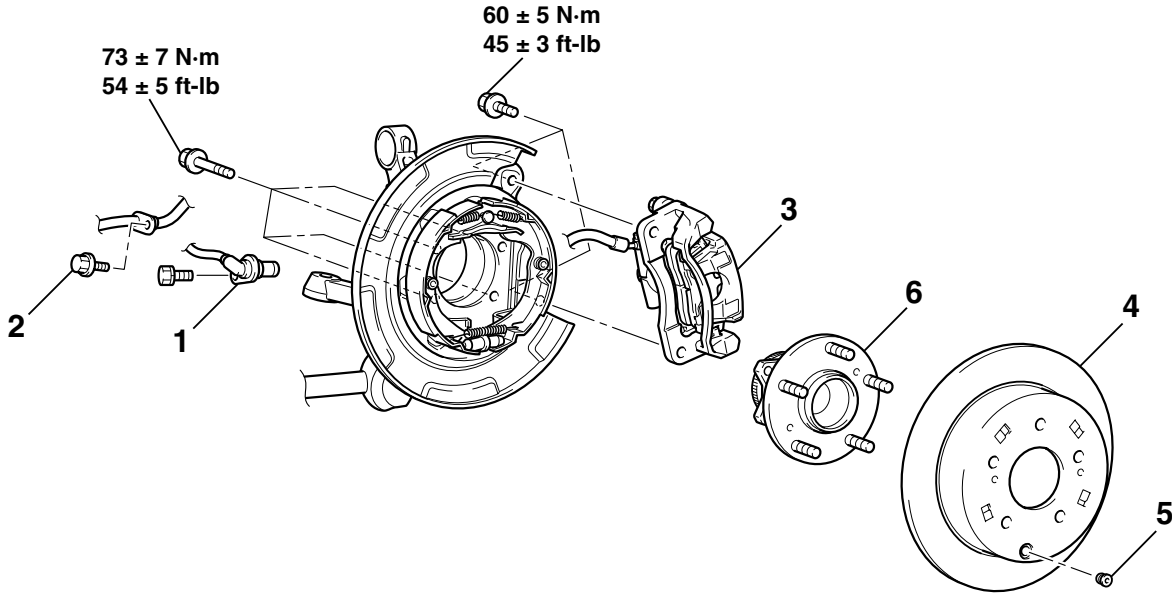

REMOVAL STEPS

1. REAR WHEEL SPEED SENSOR <VEHICLES WITH ABS> <>
2. BRAKE HOSE CLAMP BOLT <<C>>
3. CALIPER ASSEMBLY

REMOVAL STEPS (Continued)

4. BRAKE DISC
5. PLUG
6. REAR HUB ASSEMBLY

<<A>>

REMOVAL SERVICE POINT

<<A>> CALIPER ASSEMBLY REMOVAL

Secure the removed caliper assembly with wire, etc.

<> BRAKE DISC REMOVAL

If the brake disc is seized, install M8 × 1.25 bolts as shown, and remove the disc by tightening the bolts evenly and gradually.

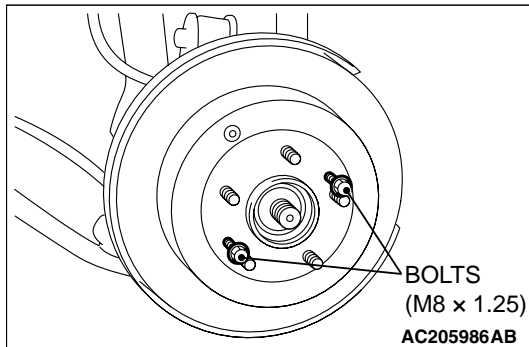

<<C>> REAR HUB ASSEMBLY REMOVAL

Insert a flat-tipped screwdriver into the mounting holes of knuckle hub to prevent the rear brake shoe and backing plate from falling down after the rear hub assembly has been removed from the knuckle.

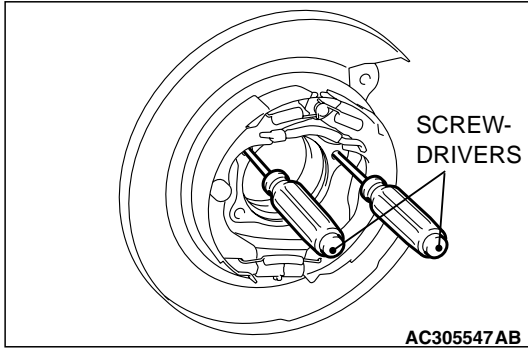

INSPECTION

- Check the ABS rotor for chipped teeth.

M1271002100270

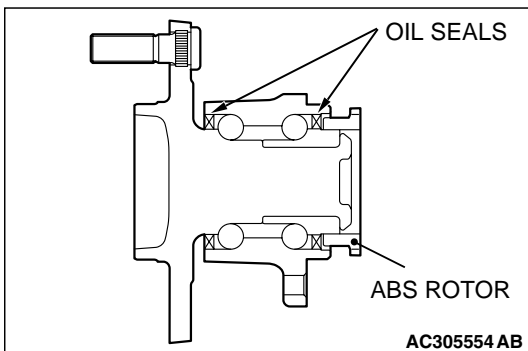

KNUCKLE

REMOVAL AND INSTALLATION

M1271003000191

CAUTION

*: Indicates parts which should be temporarily tightened, and then fully tightened with the vehicle on the ground in the unladen condition.

<p>Pre-removal Operation</p> <ul style="list-style-type: none"> • Rear Axle Hub Assembly Removal (Refer to P.27-6). • Parking Brake Assembly Removal (Refer to GROUP 36, Parking Brake Lining and Drum P.36-8). 	<p>Post-installation Operation</p> <ul style="list-style-type: none"> • Check the ball joint dust cover for cracks or damage by pushing it with your finger. • Parking Brake Assembly Installation (Refer to GROUP 36, Parking Brake Lining and Drum P.36-8). • Rear Axle Hub Assembly Installation (Refer to P.27-6).
--	--

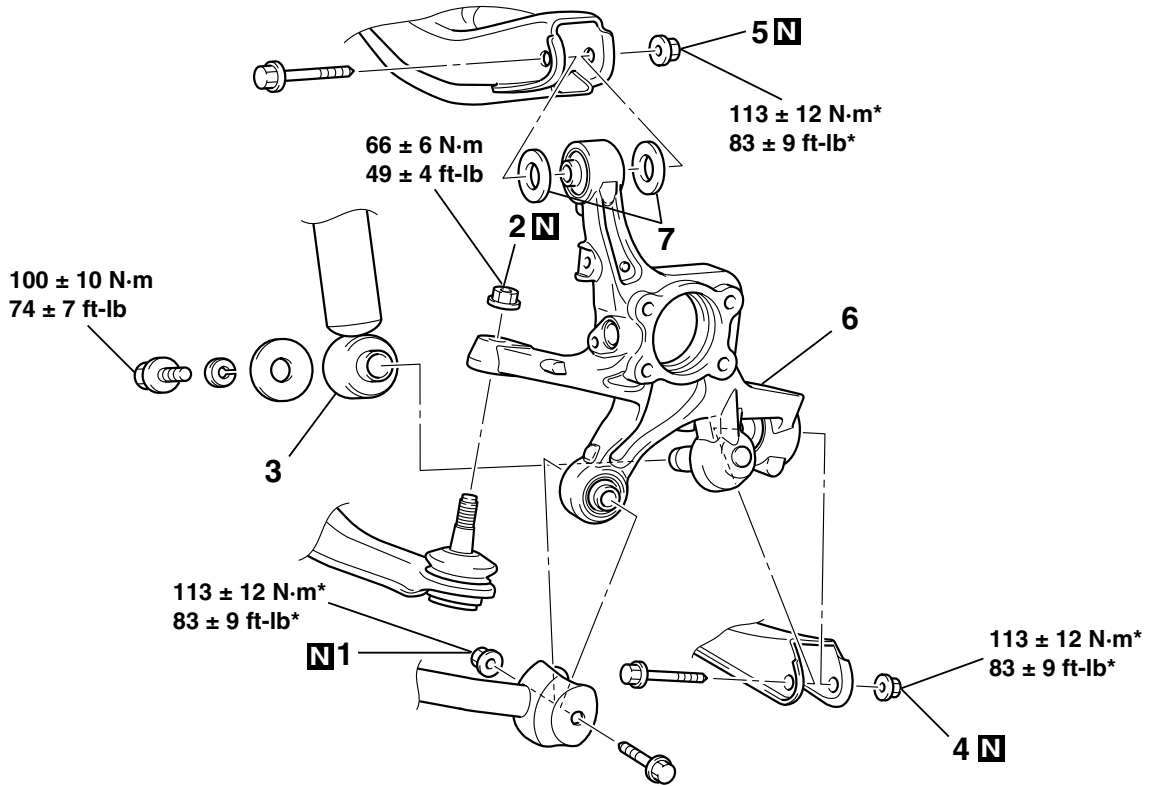

AC308327AB

REMOVAL STEPS

1. SELF LOCKING NUT (TRAILING ARM CONNECTION)
2. SELF LOCKING NUT (TOE CONTROL ARM CONNECTION)
3. SHOCK ABSORBER CONNECTION
4. SELF LOCKING NUT (LOWER ARM CONNECTION)

REMOVAL STEPS (Continued)

5. SELF LOCKING NUT (UPPER ARM CONNECTION)
6. KNUCKLE
7. UPPER ARM STOPPER

Required Special Tool:

MB991897: Ball Joint Remover

<<A>>

REMOVAL SERVICE POINT

<<A>> SELF LOCKING NUT (TOE CONTROL
ARM CONNECTION) REMOVAL

CAUTION

- Do not remove the nut from the ball joint. Loosen it and use the special tool to avoid possible damage to ball joint threads.
- Hang the special tool with a cord to prevent from falling.

1. Install special tool MB991897 as shown in the figure.

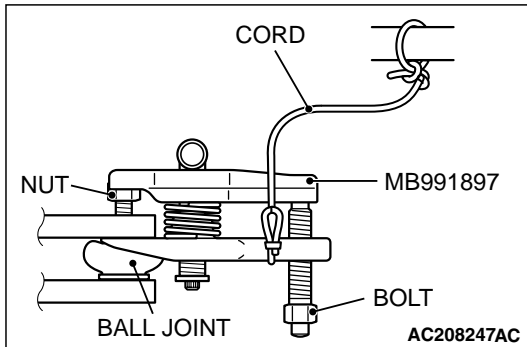

2. After turning the bolt and knob to adjust the arms of special tool MB991897 in parallel, tighten the bolt by hand and confirm that the arms are parallel.

NOTE: When adjusting the arms in parallel, turn the knob in the direction shown in the figure.

3. Tighten the bolt with a wrench to disconnect the ball joint and remove the self locking nut.

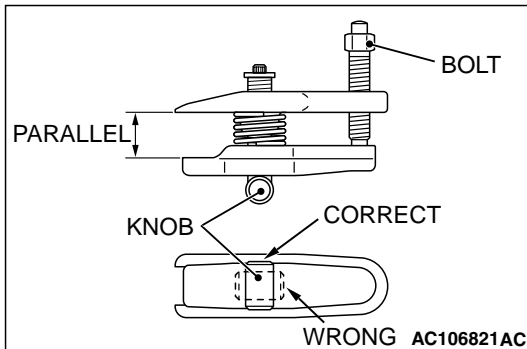

INSPECTION

Check the knuckle for wear or cracks.

M1271003100143

SPECIFICATIONS**FASTENER TIGHTENING SPECIFICATIONS**

M1271004000332

ITEM		SPECIFICATION
Knuckle	Lower arm assembly to knuckle nut	113 ± 12 N·m (83 ± 9 ft-lb)
	Shock absorber assembly to knuckle bolt	100 ± 10 N·m (74 ± 7 ft-lb)
	Self locking nut (toe control arm connection)	66 ± 6 N·m (49 ± 4 ft-lb)
	Trailing arm assembly to knuckle nut	113 ± 12 N·m (83 ± 9 ft-lb)
	Upper arm assembly to knuckle nut	113 ± 12 N·m (83 ± 9 ft-lb)
Rear axle hub assembly	Brake caliper assembly bolt	60 ± 5 N·m (45 ± 3 ft-lb)
	Rear hub assembly bolt	73 ± 7 N·m (54 ± 5 ft-lb)

SERVICE SPECIFICATIONS

M1271000300502

ITEM	LIMIT
Wheel bearing end play mm (in)	0.05 (0.002)
Rear hub rotary-sliding resistance N (lb)	24 (5.4)