

DTC P0421: Warm Up Catalyst Efficiency Below Threshold (cylinder 1, 4)

TECHNICAL DESCRIPTION

- The signal from the rear heated oxygen sensor differs from the front heated oxygen sensor. That is because the catalytic converter purifies exhaust gas. When the catalytic converter has deteriorated, the signal from the front heated oxygen sensor becomes similar to the rear heated oxygen sensor.
- The PCM compares the output of the front and rear heated oxygen sensor signals.

DESCRIPTIONS OF MONITOR METHODS

Front and rear heated oxygen sensor rich/lean switching frequencies are nearly equal.

MONITOR EXECUTION

Continuous

**MONITOR EXECUTION CONDITIONS
(Other monitor and Sensor)**

Other Monitor (There is no temporary DTC stored in memory for the item monitored below)

- Heated oxygen sensor (front) monitor
- Heated oxygen sensor (rear) monitor
- Heated oxygen sensor heater (front) monitor
- Heated oxygen sensor heater (rear) monitor
- Misfire monitor
- Fuel system monitor
- Air/fuel ratio feedback monitor

Sensor (The sensor below is determined to be normal)

- Mass airflow sensor
- Engine coolant temperature sensor
- Intake air temperature sensor
- Barometric pressure sensor
- Throttle position sensor
- Accelerator pedal position sensor

DTC SET CONDITIONS

Logic Flow Chart

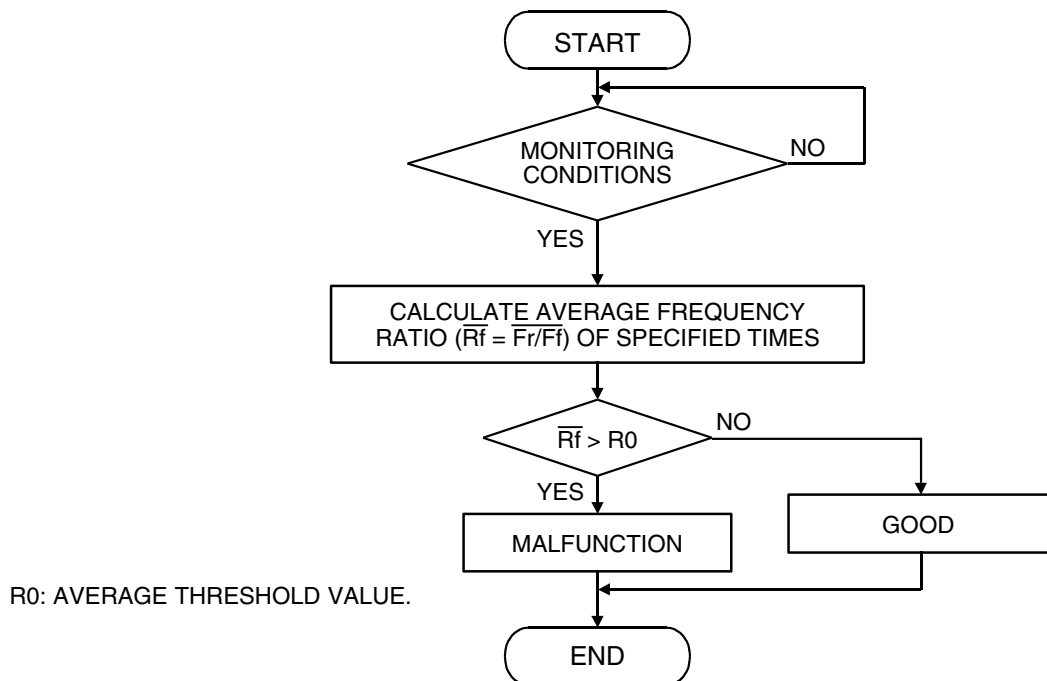

Check Conditions

- Engine speed is lower than 3,000 r/min.
- Accelerator pedal is open.
- Mass airflow is between 14 and 45 g/sec.
- More than 3 seconds have elapsed after the above-mentioned three conditions have been met.
- Intake air temperature is higher than -10°C (14°F).
- Barometric pressure is higher than 76 kPa (22.4 in.Hg).
- Under the closed loop air/fuel ratio control.
- Vehicle speed is 1.5 km/h (1.0 mph) or more.
- The PCM monitors for this condition for 5 cycles of 10 seconds each during the drive cycle.
- Short-term fuel trim is higher than -25 percent and lower than $+25$ percent.
- The cumulative mass airflow is higher than 1,638 g.

Judgment Criteria

- The frequency ratio of cylinder 1, 4 heated oxygen sensor (rear) and cylinder 1, 4 heated oxygen sensor (front) is more than 0.7. <Federal>
or
- The frequency ratio of cylinder 1, 4 heated oxygen sensor (rear) and cylinder 1, 4 heated oxygen sensor (front) is more than 0.6. <California>

OBD-II DRIVE CYCLE PATTERN

Refer to Diagnostic Function – OBD-II Drive Cycle – Procedure 3 – Catalytic Converter Monitor
[P. 13A-6.](#)

TROUBLESHOOTING HINTS (The most likely causes for this code to be set are:)

- Cylinder 1, 4 side catalytic converter deteriorated.
- Cylinder 1, 4 heated oxygen sensor failed.
- Exhaust leak.
- PCM failed.

DIAGNOSIS

Required Special Tools:

- MB991958: Scan tool (MUT-III Sub Assembly)
 - MB991824: V.C.I.
 - MB991827: USB Cable
 - MB991910: Main Harness A

STEP 1. Check for exhaust leak.

Q: Are there any abnormalities?

YES : Repair it. Then go to Step 7.

NO : Go to Step 2.

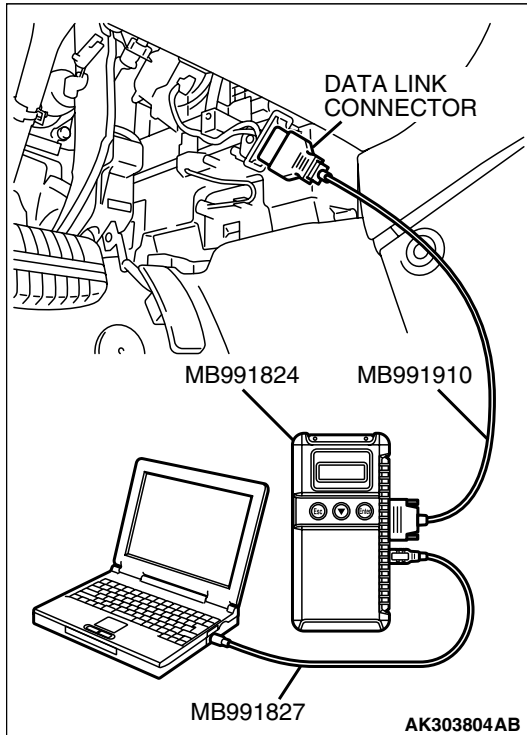

STEP 2. Using scan tool MB991958, check data list item 69: Cylinder 1, 4 Heated Oxygen Sensor (rear).

⚠ CAUTION

To prevent damage to scan tool MB991958, always turn the ignition switch to the "LOCK" (OFF) position before connecting or disconnecting scan tool MB991958.

- (1) Connect scan tool MB991958 to the data link connector.
- (2) Start the engine and run at idle.
- (3) Set scan tool MB991958 to the data reading mode for item 69, Cylinder 1, 4 Heated Oxygen Sensor (rear).
 - Warming up the engine. When the engine is revved, the output voltage should repeat 0 volt and 0.6 to 1.0 volt alternately.
- (4) Turn the ignition switch to the "LOCK" (OFF) position.

Q: Is the sensor operating properly?

YES : Go to Step 3.

NO : Refer to DTC P0136 – Cylinder 1, 4 Heated Oxygen Sensor Circuit (Sensor 2) [P. 13A-250](#), DTC P0137 – Cylinder 1, 4 Heated Oxygen Sensor Circuit Low Voltage (Sensor 2) [P. 13A-268](#), DTC P0138 – Cylinder 1, 4 Heated Oxygen Sensor Circuit High Voltage (Sensor 2) [P. 13A-275](#), DTC P0139 – Cylinder 1, 4 Heated Oxygen Sensor Circuit Slow Response (Sensor 2) [P. 13A-280](#).

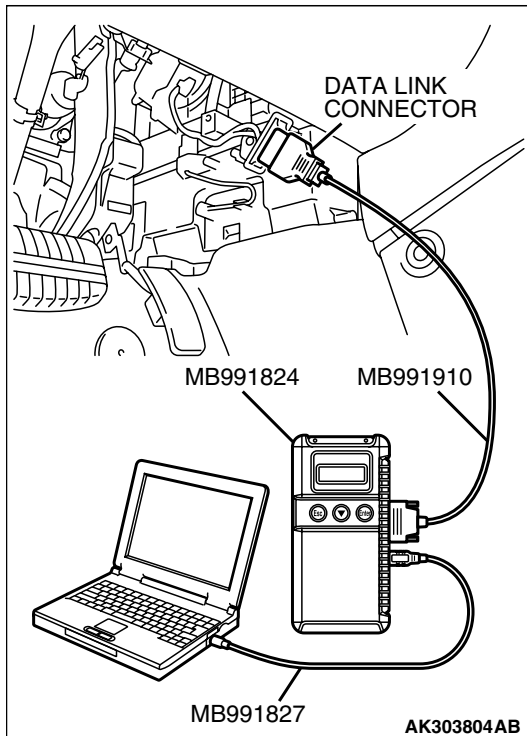

STEP 3. Using scan tool MB991958, check data list item 39: Cylinder 1, 4 Heated Oxygen Sensor (front).

- (1) Start the engine and run at idle.
- (2) Set scan tool MB991958 to the data reading mode for item 39, Cylinder 1, 4 Heated Oxygen Sensor (front).
 - Warming up the engine. When the engine is revved, the output voltage should be 0.6 to 1.0 volt.
- (3) Turn the ignition switch to the "LOCK" (OFF) position.

Q: Is the sensor operating properly?

YES : Go to Step 4.

NO : Refer to DTC P0130 – Cylinder 1, 4 Heated Oxygen Sensor Circuit (Sensor 1) [P. 13A-192](#), DTC P0131 – Cylinder 1, 4 Heated Oxygen Sensor Circuit Low Voltage (Sensor 1) [P. 13A-210](#), DTC P0132 – Cylinder 1, 4 Heated Oxygen Sensor Circuit High Voltage (Sensor 1) [P. 13A-217](#), DTC P0133 – Cylinder 1, 4 Heated Oxygen Sensor Circuit Slow Response (Sensor 1) [P. 13A-222](#), DTC P0134 – Cylinder 1, 4 Heated Oxygen Sensor Circuit No Activity Detected (Sensor 1) [P. 13A-228](#).

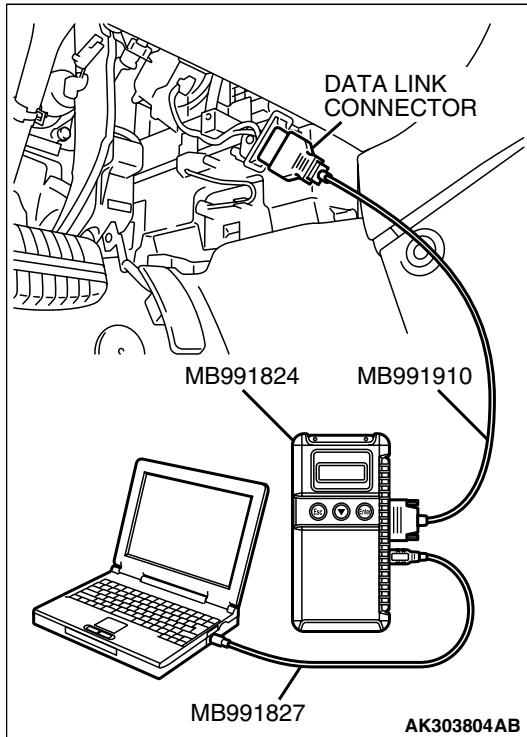

STEP 4. Using scan tool MB991958, check data list item 39: Cylinder 1, 4 Heated Oxygen Sensor (front).

- (1) Start the engine and run at idle.
- (2) Set scan tool MB991958 to the data reading mode for item 39, Cylinder 1, 4 Heated Oxygen Sensor (front).
- (3) Keep the engine speed at 2,000 r/min.
 - 0 – 0.4 and 0.6 – 1.0 volt should alternate 15 times or more within 10 seconds.
- (4) Turn the ignition switch to the "LOCK" (OFF) position.

Q: Is the sensor operating properly?

YES : Go to Step 5.

NO : Replace the cylinder 1, 4 heated oxygen sensor (front). Then go to Step 7.

STEP 5. Test the OBD-II drive cycle.

- (1) Carry out a test drive with the drive cycle pattern. Refer to Diagnostic Function – OBD-II Drive Cycle – Procedure 3 – Catalytic Converter Monitor [P.13A-6](#).
- (2) Read the diagnostic trouble code.

Q: Is DTC P0421 set?

YES : Replace the cylinder 1, 4 side catalytic converter. Then go to Step 6.

NO : The inspection is complete.

STEP 6. Test the OBD-II drive cycle.

- (1) Carry out a test drive with the drive cycle pattern. Refer to Diagnostic Function – OBD-II Drive Cycle – Procedure 3 – Catalytic Converter Monitor [P.13A-6](#).
- (2) Read the diagnostic trouble code.

Q: Is DTC P0421 set?

YES : Replace the PCM. Then go to Step 7.

NO : The inspection is complete.

STEP 7. Test the OBD-II drive cycle.

- (1) Carry out a test drive with the drive cycle pattern. Refer to Diagnostic Function – OBD-II Drive Cycle – Procedure 3 – Catalytic Converter Monitor [P.13A-6](#).
- (2) Check the diagnostic trouble code (DTC).

Q: Is DTC P0421 set?**YES** : Retry the troubleshooting.**NO** : The inspection is complete.**DTC P0431: Warm Up Catalyst Efficiency Below Threshold (cylinder 2, 3)****TECHNICAL DESCRIPTION**

- The signal from the rear heated oxygen sensor differs from the front heated oxygen sensor. That is because the catalytic converter purifies exhaust gas. When the catalytic converter has deteriorated, the signal from the front heated oxygen sensor becomes similar to the rear heated oxygen sensor.
- The PCM compares the output of the front and rear heated oxygen sensor signals.

DESCRIPTIONS OF MONITOR METHODS

Front and rear heated oxygen sensor rich/lean switching frequencies are nearly equal.

MONITOR EXECUTION

Continuous

**MONITOR EXECUTION CONDITIONS
(Other monitor and Sensor)****Other Monitor (There is no temporary DTC stored in memory for the item monitored below)**

- Heated oxygen sensor (front) monitor
- Heated oxygen sensor (rear) monitor
- Heated oxygen sensor heater (front) monitor
- Heated oxygen sensor heater (rear) monitor
- Misfire monitor
- Fuel system monitor
- Air/fuel ratio feedback monitor

Sensor (The sensor below is determined to be normal)

- Mass airflow sensor
- Engine coolant temperature sensor
- Intake air temperature sensor
- Barometric pressure sensor
- Throttle position sensor
- Accelerator pedal position sensor

DTC SET CONDITIONS

Logic Flow Chart

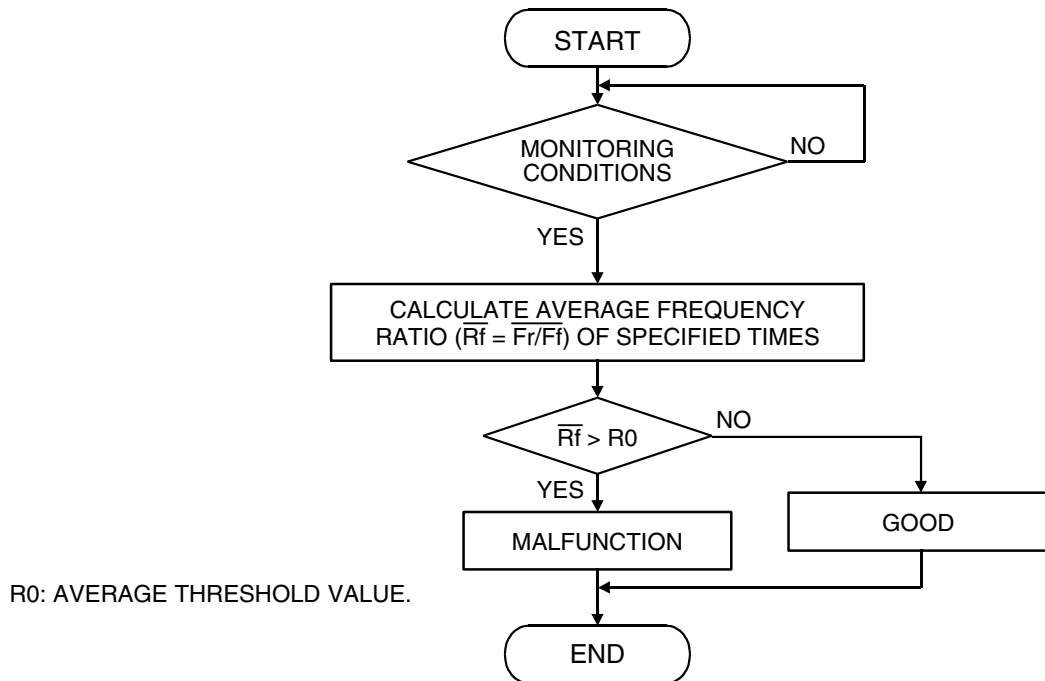

AK302038

Check Conditions

- Engine speed is lower than 3,000 r/min.
- Accelerator pedal is open.
- Mass airflow is between 14 and 45 g/sec.
- More than 3 seconds have elapsed after the above-mentioned three conditions have been met.
- Intake air temperature is higher than -10°C (14°F).
- Barometric pressure is higher than 76 kPa (22.4 in.Hg).
- Under the closed loop air/fuel ratio control.
- Vehicle speed is 1.5 km/h (1.0 mph) or more.
- The PCM monitors for this condition for 5 cycles of 10 seconds each during the drive cycle.
- Short-term fuel trim is higher than -25 percent and lower than $+25$ percent.
- The cumulative mass airflow is higher than 1,638 g.

Judgment Criteria

- The frequency ratio of left bank heated oxygen sensor (rear) and left bank heated oxygen sensor (front) is more than 0.7. <Federal>
- or
- The frequency ratio of left bank heated oxygen sensor (rear) and left bank heated oxygen sensor (front) is more than 0.6. <California>

OBD-II DRIVE CYCLE PATTERN

Refer to Diagnostic Function – OBD-II Drive Cycle – Procedure 3 – Catalytic Converter Monitor
[P. 13A-6.](#)

TROUBLESHOOTING HINTS (The most likely causes for this code to be set are:)

- Cylinder 2, 3 side catalytic converter deteriorated.
- Cylinder 2, 3 heated oxygen sensor failed.
- Exhaust leak.
- PCM failed.

DIAGNOSIS**Required Special Tools:**

- MB991958: Scan tool (MUT-III Sub Assembly)
 - MB991824: V.C.I.
 - MB991827: USB Cable
 - MB991910: Main Harness A

STEP 1. Check for exhaust leak.**Q: Are there any abnormalities?****YES** : Repair it. Then go to Step 7.**NO** : Go to Step 2.**STEP 2. Using scan tool MB991958, check data list item 59: Cylinder 2, 3 Heated Oxygen Sensor (rear).****⚠ CAUTION**

To prevent damage to scan tool MB991958, always turn the ignition switch to the "LOCK" (OFF) position before connecting or disconnecting scan tool MB991958.

- (1) Connect scan tool MB991958 to the data link connector.
- (2) Start the engine and run at idle.
- (3) Set scan tool MB991958 to the data reading mode for item 59, Cylinder 2, 3 Heated Oxygen Sensor (rear).
 - Warming up the engine. When the engine is revved, the output voltage should repeat 0 volt and 0.6 to 1.0 volt alternately.
- (4) Turn the ignition switch to the "LOCK" (OFF) position.

Q: Is the sensor operating properly?**YES** : Go to Step 3.

NO : Refer to DTC P0156 – Cylinder 2, 3 Heated Oxygen Sensor Circuit (Sensor 2) [P. 13A-357](#), DTC P0157 – Cylinder 2, 3 Heated Oxygen Sensor Circuit Low Voltage (Sensor 2) [P. 13A-375](#), DTC P0158 – Cylinder 2, 3 Heated Oxygen Sensor Circuit High Voltage (Sensor 2) [P. 13A-382](#), DTC P0159 – Cylinder 2, 3 Heated Oxygen Sensor Circuit Slow Response (Sensor 2) [P. 13A-387](#).

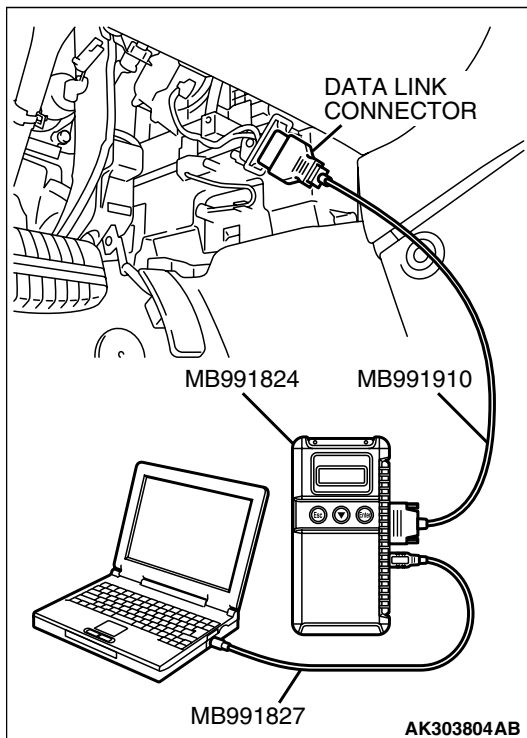

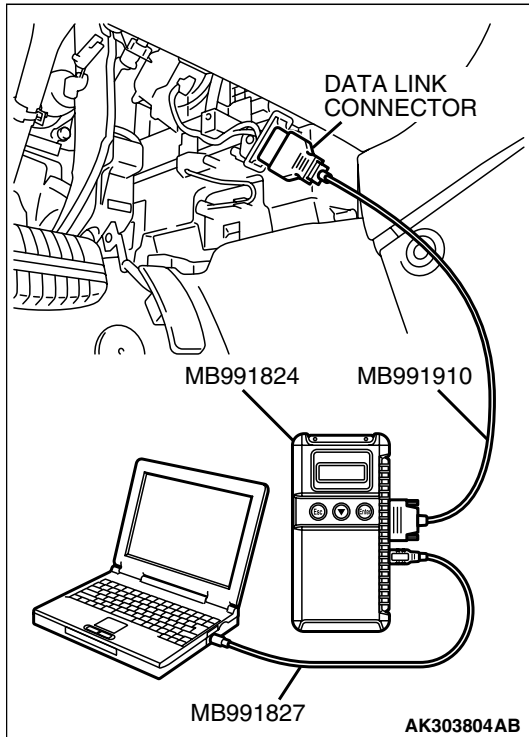

STEP 3. Using scan tool MB991958, check data list item 11: Cylinder 2, 3 Heated Oxygen Sensor (front).

- (1) Start the engine and run at idle.
- (2) Set scan tool MB991958 to the data reading mode for item 11, Cylinder 2, 3 Heated Oxygen Sensor (front).
 - Warming up the engine. When the engine is revved, the output voltage should be 0.6 to 1.0 volt.
- (3) Turn the ignition switch to the "LOCK" (OFF) position.

Q: Is the sensor operating properly?

YES : Go to Step 4.

NO : Refer to DTC P0150 – Cylinder 2, 3 Heated Oxygen Sensor Circuit (Sensor 1) [P. 13A-299](#), DTC P0151 – Cylinder 2, 3 Heated Oxygen Sensor Circuit Low Voltage (Sensor 1) [P. 13A-317](#), DTC P0152 – Cylinder 2, 3 Heated Oxygen Sensor Circuit High Voltage (Sensor 1) [P. 13A-324](#), DTC P0153 – Cylinder 2, 3 Heated Oxygen Sensor Circuit Slow Response (Sensor 1) [P. 13A-329](#), DTC P0154 – Cylinder 2, 3 Heated Oxygen Sensor Circuit No Activity Detected (Sensor 1) [P. 13A-335](#).

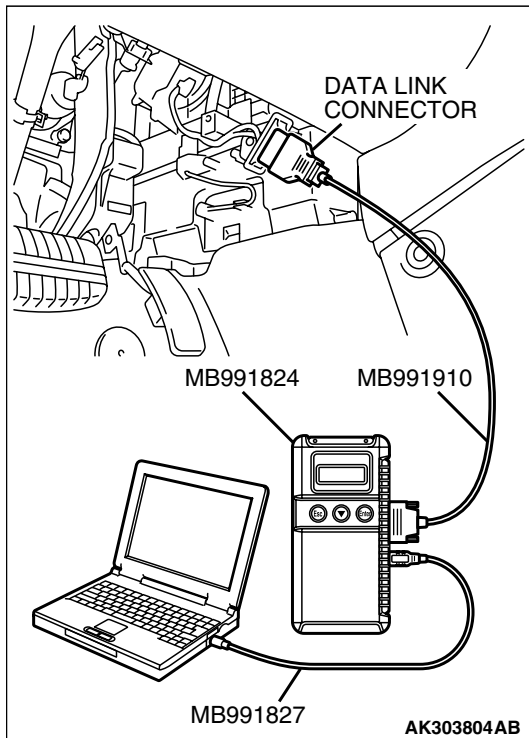

STEP 4. Using scan tool MB991958, check data list item 11: Cylinder 2, 3 Heated Oxygen Sensor (front).

- (1) Start the engine and run at idle.
- (2) Set scan tool MB991958 to the data reading mode for item 11, Cylinder 2, 3 Heated Oxygen Sensor (front).
- (3) Keep the engine speed at 2,000 r/min.
 - 0 – 0.4 and 0.6 – 1.0 volt should alternate 15 times or more within 10 seconds.
- (4) Turn the ignition switch to the "LOCK" (OFF) position.

Q: Is the sensor operating properly?

YES : Go to Step 5.

NO : Replace the cylinder 2, 3 heated oxygen sensor (front). Then go to Step 7.

STEP 5. Test the OBD-II drive cycle.

- (1) Carry out a test drive with the drive cycle pattern. Refer to Diagnostic Function – OBD-II Drive Cycle – Procedure 3 – Catalytic Converter Monitor [P.13A-6](#).
- (2) Read the diagnostic trouble code.

Q: Is DTC P0431 set?

- YES** : Replace the cylinder 2, 3 side catalytic converter.
Then go to Step 6.
- NO** : The inspection is complete.

STEP 6. Test the OBD-II drive cycle.

- (1) Carry out a test drive with the drive cycle pattern. Refer to Diagnostic Function – OBD-II Drive Cycle – Procedure 3 – Catalytic Converter Monitor [P.13A-6](#).
- (2) Read the diagnostic trouble code.

Q: Is DTC P0431 set?

- YES** : Replace the PCM. Then go to Step 7.
- NO** : The inspection is complete.

STEP 7. Test the OBD-II drive cycle.

- (1) Carry out a test drive with the drive cycle pattern. Refer to Diagnostic Function – OBD-II Drive Cycle – Procedure 3 – Catalytic Converter Monitor [P.13A-6](#).
- (2) Check the diagnostic trouble code (DTC).

Q: Is DTC P0431 set?

- YES** : Retry the troubleshooting.
- NO** : The inspection is complete.

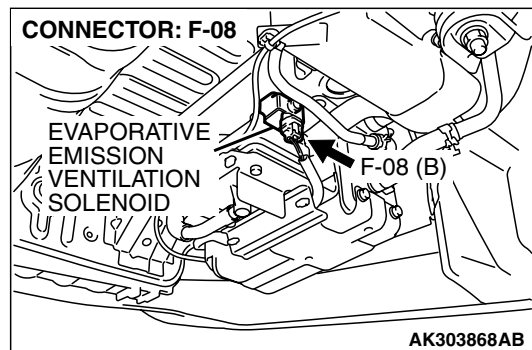
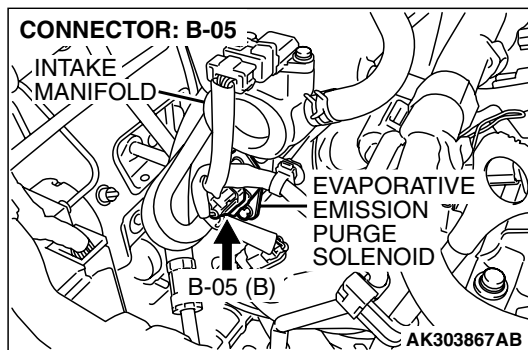
DTC P0441: Evaporative Emission Control System Incorrect Purge Flow**TECHNICAL DESCRIPTION**

- PCM detects stuck open condition of evaporative emission purge solenoid and stuck close condition of evaporative emission ventilation solenoid by pressure change in fuel tank.
- Stuck open evaporative emission purge solenoid is judged through monitoring leak of evaporative emission system.

- Stuck closed evaporative emission ventilation solenoid is judged after 20 seconds from end of monitoring leak of evaporative emission system, or of usual operation of evaporative emission purge solenoid from ON to OFF.

DESCRIPTIONS OF MONITOR METHODS

Fuel tank pressure decreases largely during purge-cut.

MONITOR EXECUTION

Continuous

**MONITOR EXECUTION CONDITIONS
(Other monitor and Sensor)**

Other Monitor (There is no temporary DTC stored in memory for the item monitored below)

- Fuel tank pressure sensor monitor

Sensor (The sensor below is determined to be normal)

- Not applicable

DTC SET CONDITIONS

Logic Flow Chart

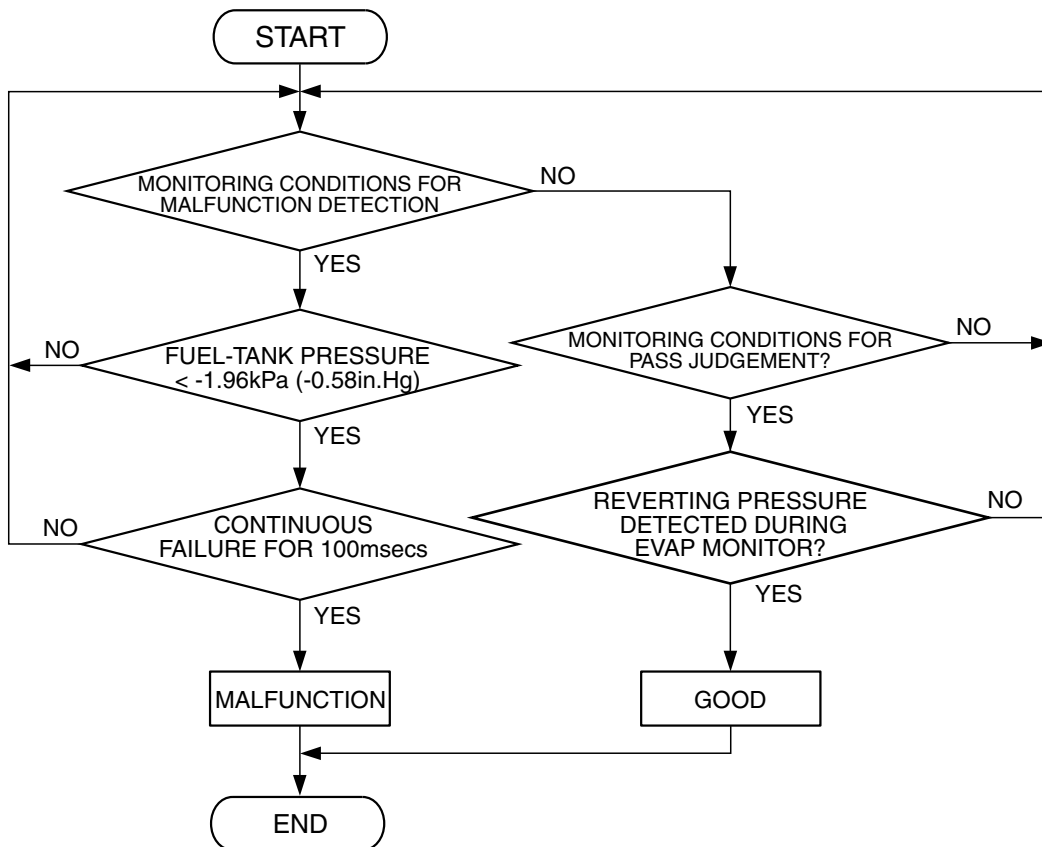

AK302230

Check Conditions

- Engine is running.
- ON duty cycle of the evaporative emission purge solenoid is 0 percent.
- 20 seconds have elapsed since the duty cycle of the evaporative emission purge solenoid has turned to 0 percent.

Judgment Criteria

- The pressure in the fuel tank is -1.96 kPa (-0.58 in.Hg) or less for 0.1 second.

OBD-II DRIVE CYCLE PATTERN

Refer to Diagnostic Function – OBD-II Drive Cycle – Procedure 1 – Evaporative Emission System Leak Monitor [P.13A-6](#).

TROUBLESHOOTING HINTS (The most likely causes for this code to be set are:)

- Evaporative emission purge solenoid failed.
- Evaporative emission ventilation solenoid failed.
- Fuel tank differential pressure sensor circuit related part(s) failed.

DIAGNOSIS**Required Special Tools:**

- MB991958: Scan Tool (MUT-III Sub Assembly)
 - MB991824: V.C.I.
 - MB991827: USB Cable
 - MB991910: Main Harness A

STEP 1. Using scan tool MB991958, read the diagnostic trouble code (DTC).

⚠ CAUTION

To prevent damage to scan tool MB991958, always turn the ignition switch to the "LOCK" (OFF) position before connecting or disconnecting scan tool MB991958.

- (1) Connect scan tool MB991958 to the data link connector.
- (2) Turn the ignition switch to the "ON" position.
- (3) Read the DTC.
- (4) Turn the ignition switch to the "LOCK" (OFF) position.

Q: Is DTC P0451 set?

YES : Refer to DTC P0451 - Evaporative Emission Control System Pressure Sensor Range/Performance

[P.13A-669.](#)

NO : Go to Step 2.

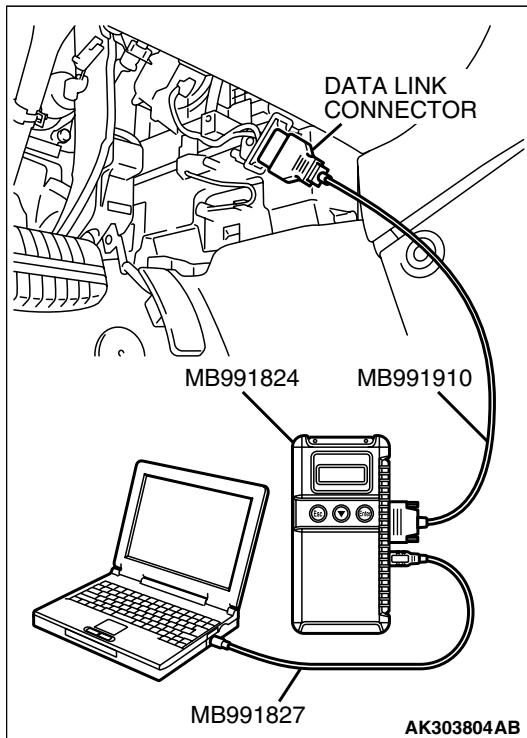

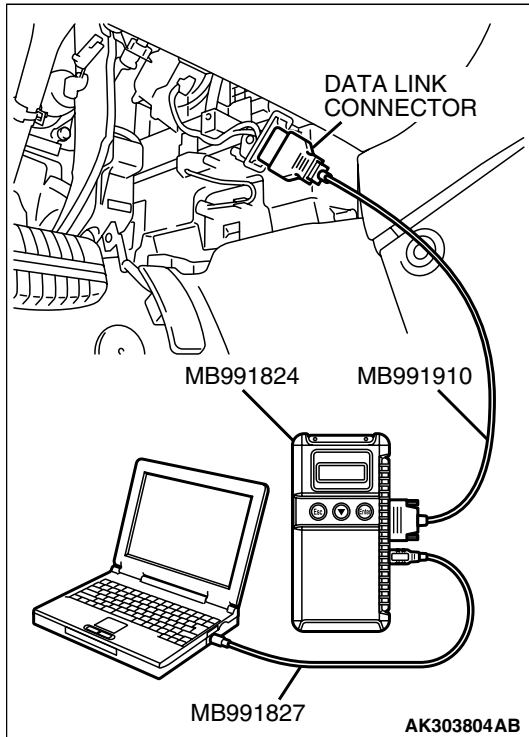

STEP 2. Using scan tool MB991958, check data list item 73: Fuel Tank Differential Pressure Sensor.

- (1) Turn the ignition switch to the "ON" position.
- (2) Remove the fuel cap.
- (3) Set scan tool MB991958 to the data reading mode for item 73, Fuel Tank Differential Pressure Sensor.
 - The fuel tank differential pressures should be -3.3 to 3.3 kPa (-0.97 to 0.97 in.Hg).
- (4) Turn the ignition switch to the "LOCK" (OFF) position.

Q: Is the fuel tank pressure between -3.3 to 3.3 kPa (-0.97 to 0.97 in.Hg)?

YES : Go to Step 3.

NO : Refer to DTC P0451 - Evaporative Emission Control System Pressure Sensor Range/Performance
[P.13A-669.](#)

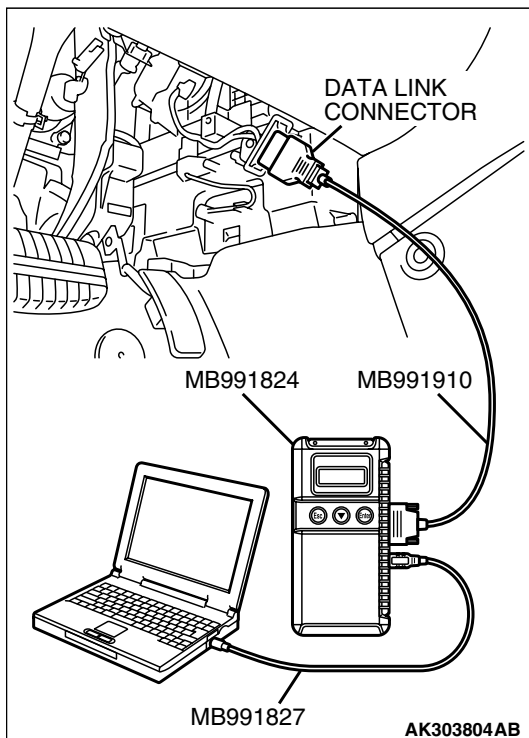

STEP 3. Using scan tool MB991958, check actuator test item 08: Evaporative Emission Purge Solenoid.

- (1) Turn the ignition switch to the "ON" position.
- (2) Set scan tool MB991958 to the actuator test mode for item 08, Evaporative emission purge solenoid.
 - An operation sound should be heard and vibration should be felt when the evaporative emission purge solenoid is operated.
- (3) Turn the ignition switch to the "LOCK" (OFF) position.

Q: Is the solenoid operating properly?

YES : Go to Step 4.

NO : Replace the evaporative emission purge solenoid.
Then go to Step 5.

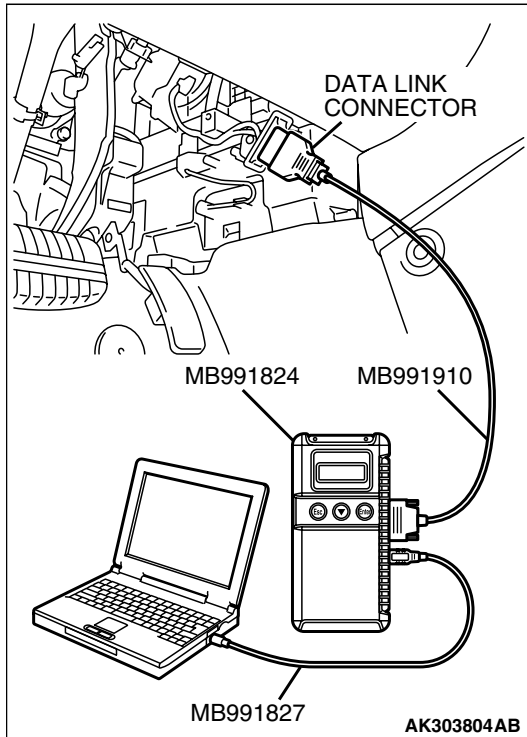

STEP 4. Using scan tool MB991958, check actuator test item 29: Evaporative Emission Ventilation Solenoid.

- (1) Turn the ignition switch to the "ON" position.
- (2) Set scan tool MB991958 to the actuator test mode for item 29, Evaporative emission ventilation solenoid.
 - An operation sound should be heard and vibration should be felt when the evaporative emission ventilation solenoid is operated.
- (3) Turn the ignition switch to the "LOCK" (OFF) position.

Q: Is the solenoid operating properly?

- YES :** Repair or replace the vent hose and air filter. Then go to Step 5.
- NO :** Replace the evaporative emission ventilation solenoid. Then go to Step 5.

STEP 5. Test the OBD-II drive cycle.

- (1) Carry out a test drive with the drive cycle pattern. Refer to Diagnostic Function – OBD-II Drive Cycle – Procedure 1 – Evaporative Emission System Leak Monitor [P.13A-6](#).
- (2) Read the diagnostic trouble code.

Q: Is DTC P0441 set?

- YES :** Retry the troubleshooting.
- NO :** The inspection is complete.

DTC P0442: Evaporative Emission System Leak Detected (Small Leak)

SYSTEM DIAGRAM

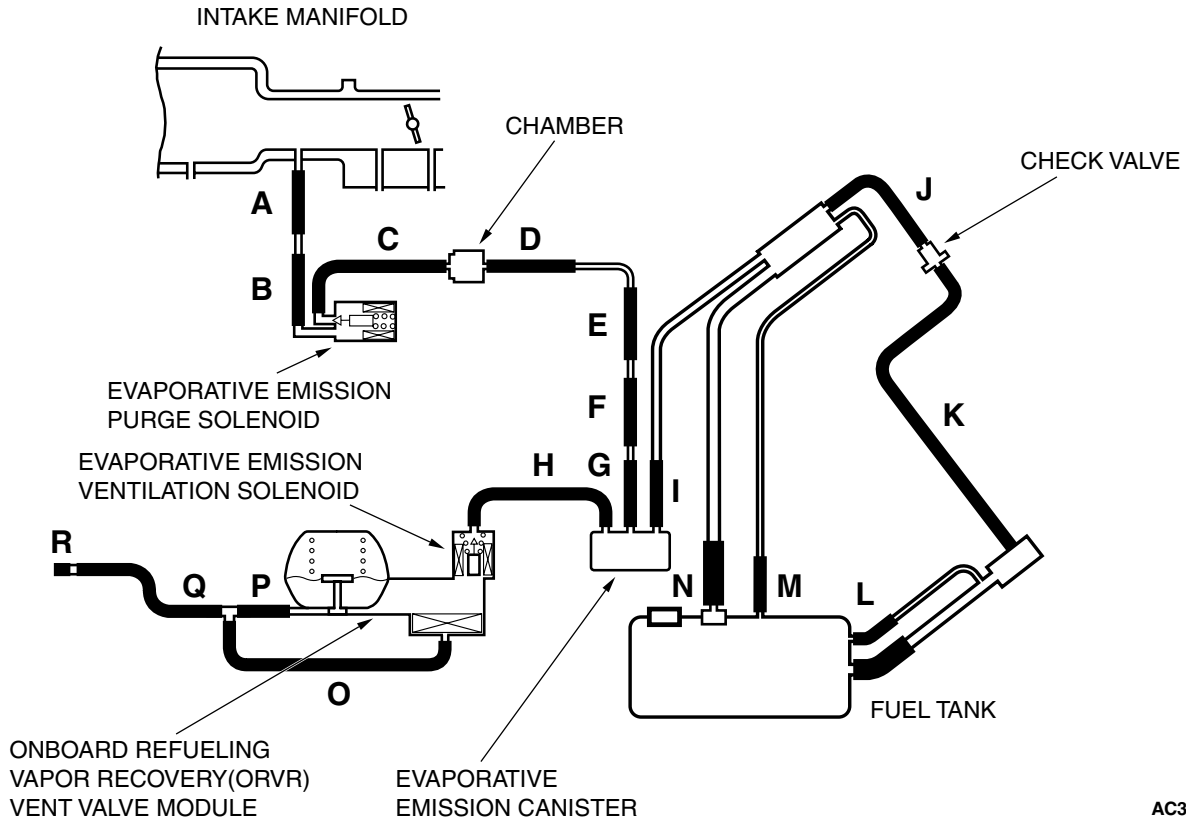

AC306277 AB

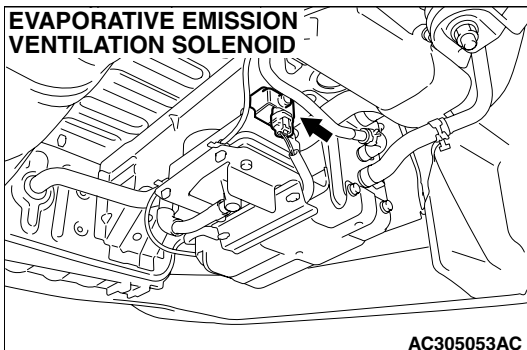
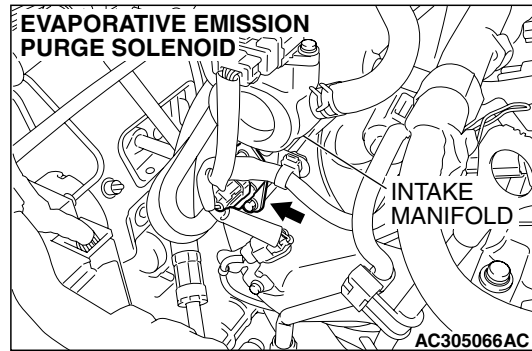
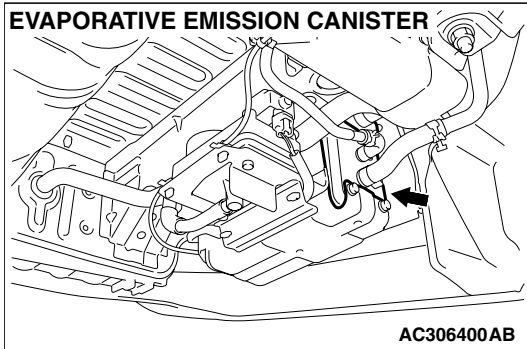

TECHNICAL DESCRIPTION

- The PCM monitors the Evaporative Emission (EVAP) System pressure.
- The PCM controls the evaporative emission ventilation solenoid. It closes the evaporative emission ventilation solenoid to seal the evaporative emission canister side of the system.
- The evaporative emission purge solenoid is opened to allow manifold vacuum to create low pressure (vacuum) in the EVAP system.
- When the EVAP system develops a vacuum of 2 kPa (0.29 psi), the evaporative emission purge solenoid is closed and the fuel system vacuum is maintained at 2 kPa. (0.29 psi).
- The PCM determines whether there is a leak in the EVAP system by monitoring the vacuum inside the fuel tank.
- The test is stopped when fuel vapor pressure exceeds predetermined limits.

DESCRIPTIONS OF MONITOR METHODS

- Measure reverting pressure after depressurizing by intake manifold negative pressure and detect malfunction if reverting pressure rises largely.

MONITOR EXECUTION

- Once per driving cycle.

MONITOR EXECUTION CONDITIONS (OTHER MONITOR AND SENSOR)**Other Monitor (There is no temporary DTC stored in memory for the item monitored below)**

- Evaporative emission purge solenoid monitor
- Evaporative emission purge system monitor
- Fuel tank differential pressure sensor monitor
- Evaporative emission ventilation solenoid monitor
- Fuel level sensor monitor
- Fuel temperature sensor monitor

Sensor (The sensors below are determined to be normal)

- Mass airflow sensor
- Barometric pressure sensor
- Intake air temperature sensor
- Engine coolant temperature sensor

LOGIC FLOW CHARTS (Monitor Sequence)

0.04in, 0.02in GROSS LEAK MONITOR

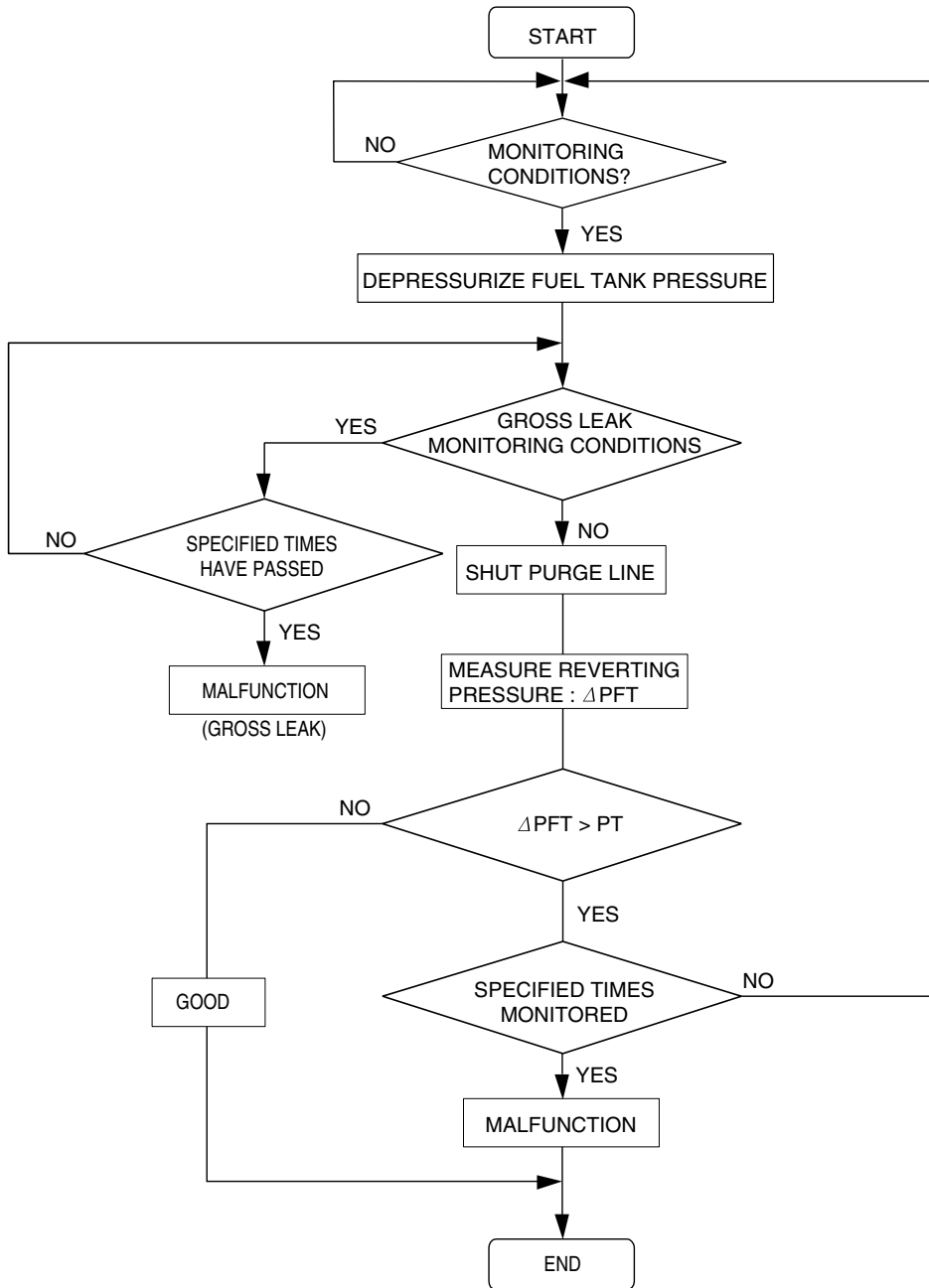

AC306649

DTC SET CONDITIONS

Remaining fuel amount is 15 – 40 percent of capacity (fuel level sensor output signal voltage is 1.4 – 2.4 volts).

Check Conditions A: At Start up

- Intake air temperature is 36 °C (97 °F) or less when the engine is started.
- The engine coolant temperature is 36 °C (97 °F) or less when the engine is started.

Check Conditions B: For Test to Run

- The fuel tank temperature is less than 36 °C (97 °F), and less than 13 minutes have elapsed since the engine was started.
- Engine coolant temperature is greater than 60°C (140°F).
- Power steering pressure switch: "OFF"
- Barometric pressure is greater than 76 kPa (11 psi).
- Fuel tank differential pressure sensor output voltage is 1 to 4 volts.
- Vehicle speed is greater than or equal to 20 km/h (12.4 mph).

Check Conditions C: For Test to Stop

- Intake air temperature is greater than –10°C (14°F).
- When the evaporative emission purge solenoid and evaporative emission ventilation solenoid are closed, the pressure in the fuel tank is less than 451 Pa (0.065 psi).
- The pressure fluctuation is less than 647 Pa (0.094 psi).
- 10 seconds have elapsed since the start of the previous monitoring.
- Monitoring time: 75 – 125 seconds.

Judgment Criteria

- Internal pressure of the fuel tank has changed more than 981 Pa (0.142 psi) in 20 seconds after the tank and vapor line were closed.

NOTE: The monitoring time (75 – 125 seconds) depends on the fuel level and the temperature in the fuel tank.

The next monitoring occurs at least 10 seconds later.

DTC SET CONDITIONS

Remaining fuel amount is 40 – 85 percent of capacity (fuel level sensor output voltage is 2.4 – 3.7 volts).

Check Conditions A: At Start up

- Intake air temperature is less than 36 °C (97 °F) when the engine is started.
- The engine coolant temperature is less than 36 °C (97 °F) when the engine is started.

Check Conditions B: For Test to Run

- The fuel tank temperature is less than 36 °C (97 °F).
- Barometric pressure is greater than 76 kPa (11 psi).
- Fuel tank differential pressure sensor output voltage is 1 to 4 volts.

Check Conditions C: For Test to Stop

- Intake air temperature is greater than –10 °C (14°F).
- Engine coolant temperature is greater than 20 °C (68 °F).
- When the evaporative emission purge solenoid and evaporative emission ventilation solenoid are closed, the pressure in the fuel tank is less than 324 Pa (0.047 psi).
- 10 seconds have elapsed since the start of the previous monitoring.
- Monitoring time: 10 – 14 minutes.

Judgment Criteria

- Internal pressure of the fuel tank has changed more than 2 kPa (0.29 psi) in 128 seconds after the tank and vapor line were closed.

NOTE: The monitoring time (10 – 14 minutes) depends on the fuel level and the temperature in the fuel tank.

The next monitoring occurs at least 10 seconds later.

OBD-II DRIVE CYCLE PATTERN

Refer to Diagnostic Function – OBD-II Drive Cycle – Procedure 1 – Evaporative Emission System Leak Monitor [P.13A-6](#).

TROUBLESHOOTING HINTS (THE MOST LIKELY CAUSES FOR THIS CODE TO BE SET ARE:)

- Loose fuel cap.
- Fuel cap relief pressure is incorrect.
- Evaporative emission canister seal is leaking.
- Fuel tank, purge line or vapor line seal is leaking.
- Evaporative emission ventilation solenoid does not seal.

DIAGNOSIS

Required Special Tools:

- MB991958: Scan Tool (MUT-III Sub Assembly)
 - MB991824: V.C.I.
 - MB991827: MUT-III USB Cable
 - MB991910: MUT-III Main Harness A

STEP 1. Using scan tool MB991958, check the evaporative emission system monitor test.

⚠ CAUTION

- To prevent damage to scan tool MB991958, always turn the ignition switch to the "LOCK" (OFF) position before connecting or disconnecting scan tool MB991958.
- During this test, the PCM will automatically increase the engine speed to 1,600 r/min or greater. Check that the transaxle is set to the "P" position.

- (1) Connect scan tool MB991958 to the data link connector.
- (2) Turn the ignition switch to the "ON" position.
- (3) Erase the DTCs using scan tool MB991958.
- (4) Check that the fuel cap is securely closed (Tighten until three clicks are heard).
- (5) Start the engine.
- (6) Select "System Test."
- (7) Select "Evap Leak Mon."
- (8) During this test, keep the accelerator pedal at the idle position.
- (9) Keep the engine speed and engine load within the specified range. When the monitor test starts, the "In Progress" item on scan tool MB991958 will change from "NO" to "YES."
- (10) Turn the ignition switch to the "LOCK" (OFF) position, and disconnect scan tool MB991958.

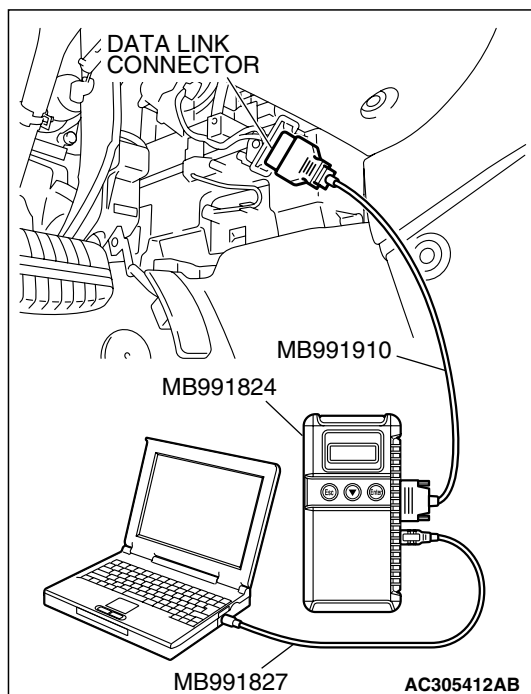

Q: Is "Evap Leak Mon. Completed. Test Failed and DTCs Set" displayed on scan tool MB991958?

YES : A malfunction has been detected during the monitor test. Refer to the Diagnostic Trouble Code Chart and diagnose any other DTCs that are set [P.13A-33](#). If no other DTC's have been set, go to Step 2.

NO <"Evap Leak Mon. Completed. Test Passed" is displayed on scan tool MB991958.> : The evaporative emission system is working properly at this time. Explain to the customer that an improperly tightened fuel cap can cause the MIL to illuminate. Return the vehicle to the customer.

NO <"Evap Leak Mon. Discontinued. Retest again from the first" is displayed on scan tool MB991958.> : The EVAP monitor has been interrupted during the test. Turn the ignition switch to the "LOCK" (OFF) position once, and repeat the monitoring from Step 1.

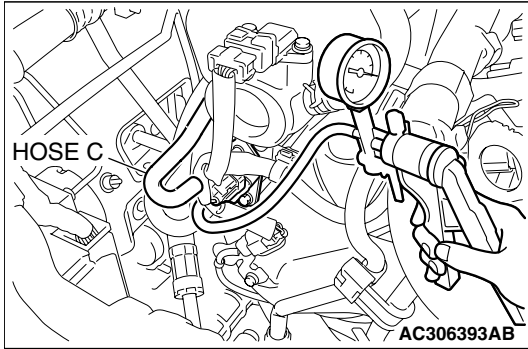

STEP 2. Check the evaporative emission purge solenoid for leaks.

- (1) Disconnect hose C from the evaporative emission purge solenoid and connect a hand vacuum pump to the nipple of the evaporative emission purge solenoid.
- (2) Use the hand vacuum pump to confirm that the evaporative emission purge solenoid holds vacuum.
- (3) Disconnect the hand vacuum pump, and reconnect hose C to the evaporative emission purge solenoid.

Q: Does the evaporative emission purge solenoid hold vacuum?

YES : Go to Step 3.

NO : Replace the evaporative emission purge solenoid.
Then go to Step 15.

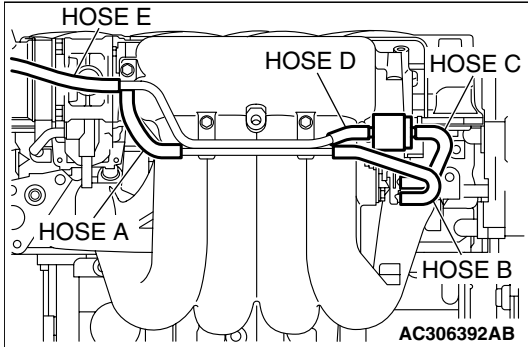

STEP 3. Check for leaks in evaporative emission hoses A through E.

Use a hand vacuum pump to test each hose from hose A to hose E.

Q: Do the hoses hold vacuum?

YES : Go to Step 4.

NO : Replace any damaged hose. Then go to Step 15.

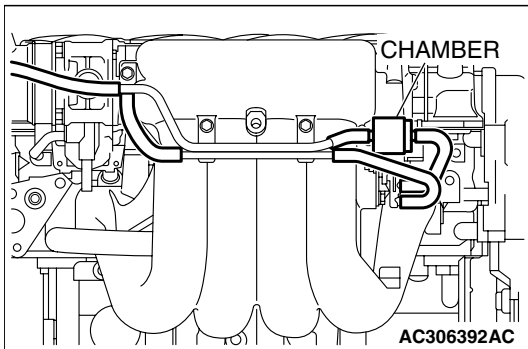

STEP 4. Check for leaks in the chamber.

- (1) Connect a hand vacuum pump to the nipple.
- (2) Plug the other nipple.
- (3) Apply vacuum with the hand vacuum pump, and confirm that the applied vacuum does not fluctuate.

Q: Is the chamber in good condition?

YES : Go to Step 5.

NO : Replace the chamber. Then go to Step 15.

STEP 5. Check for leaks in evaporative emission hoses F through H.

Use a hand vacuum pump to test each hose from hose F to hose H.

Q: Do the hoses hold vacuum?

YES : Go to Step 6.

NO : Replace any damaged hose. Then go to Step 15.

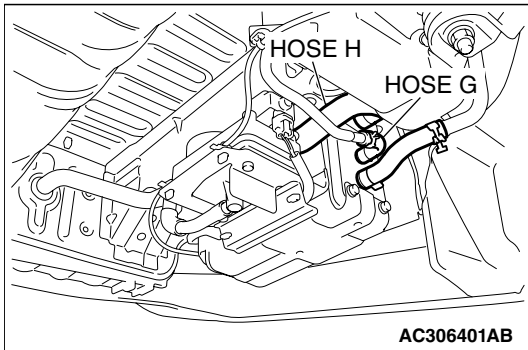
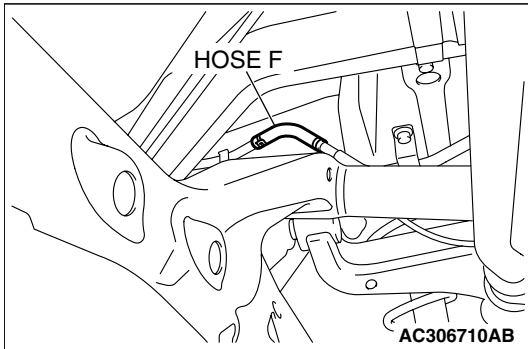

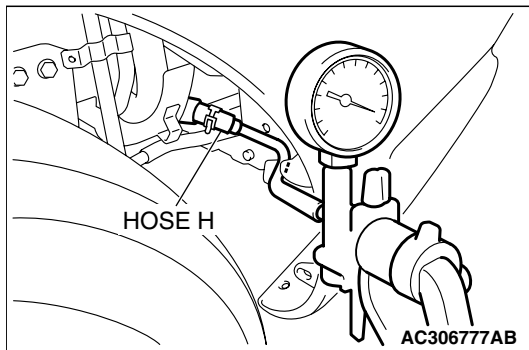
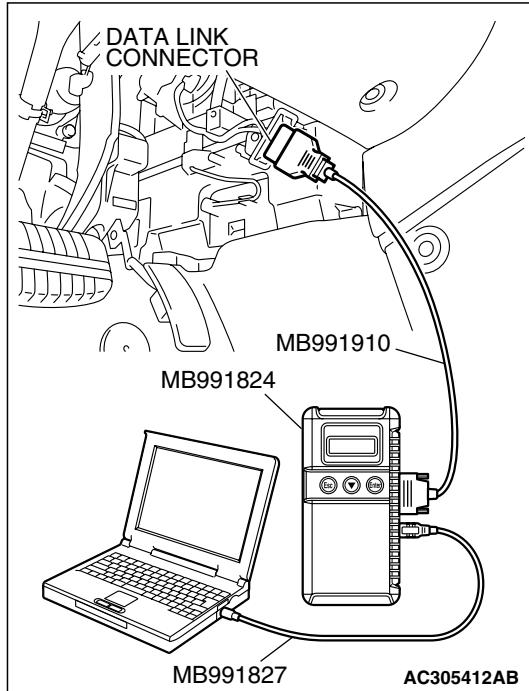

STEP 6. Using scan tool MB991958, check data list item 29: Evaporative emission ventilation solenoid.

⚠ CAUTION

To prevent damage to scan tool MB991958, always turn the ignition switch to the "LOCK" (OFF) position before connecting or disconnecting scan tool MB991958.

- (1) Connect scan tool MB991958 to the data link connector.
- (2) Remove the fuel tank filler tube protector (Refer to GROUP 13C, Fuel Tank P.13C-10).

- (3) Disconnect hose H from evaporative emission canister and connect hand vacuum pump to hose H.
- (4) Turn the ignition switch to the "ON" position.
- (5) Set scan tool MB991958 to actuator test mode.
 - Item 29: Evaporative Emission Ventilation Solenoid.
 - While the evaporative emission ventilation solenoid is energized, operate the hand vacuum pump and confirm that the solenoid holds vacuum.
- (6) Turn the ignition switch to the "LOCK" (OFF) position, and disconnect scan tool MB991958.
- (7) Disconnect the hand vacuum pump, and connect hose H to the evaporative emission canister.
- (8) Reinstall the fuel tank filler tube protector (Refer to GROUP 13C, Fuel Tank P.13C-10).

Q: Did the evaporative emission ventilation solenoid hold vacuum?

YES : Go to Step 7.

NO : Replace the evaporative emission ventilation solenoid (Refer to GROUP 17, Evaporative emission canister and fuel tank pressure relief valve removal and installation P.17-95). Then go to Step 15.

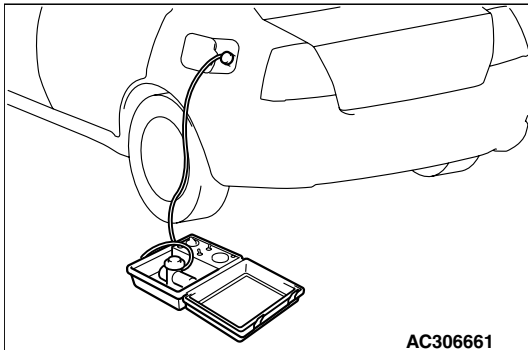
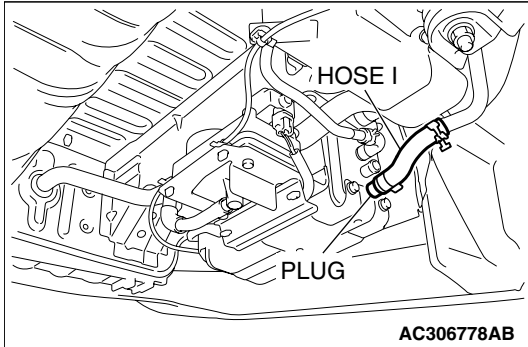

STEP 7. Pressure test the evaporative emission system lines from hoses I to N.

- (1) Disconnect hose I from the evaporative emission canister, and plug hose I securely.
- (2) Confirm that the evaporative emission system pressure pump (Miller number 6872A) is operating properly. Perform the self-test as described in the pump manufacturer's instructions.
- (3) Remove the fuel cap.

- (4) Connect the evaporative emission system pressure pump (Miller number 6872A) to the fuel tank filler tube by using fuel tank adapter (MLR-8382).
- (5) Pressure test the system to determine whether any leaks are present.

NOTE: The "Pressure test" in this procedure refers to the I/M240 Simulation Test. The eight steps of this test are described in the manufacturer's instructions for the evaporative emission system pressure pump, Miller number 6872A.

- (6) Remove the evaporative emission system pressure pump (Miller number 6872A) and the fuel tank adapter (MLR-8382), and reinstall the fuel cap.
- (7) Connect hose I to the evaporative emission canister.

Q: Is the evaporative emission system line free of leaks?

YES : Go to Step 13.

NO : Go to Step 8.

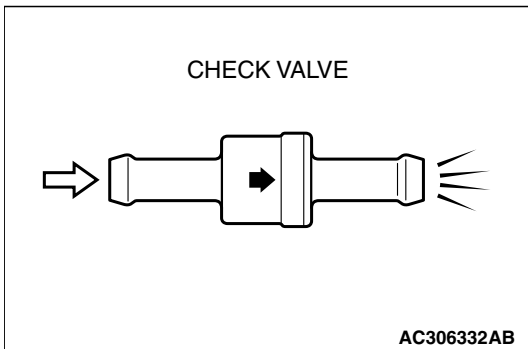
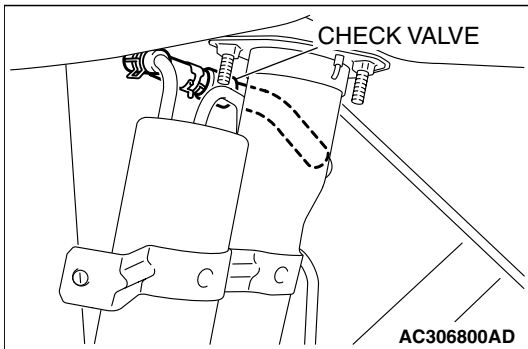
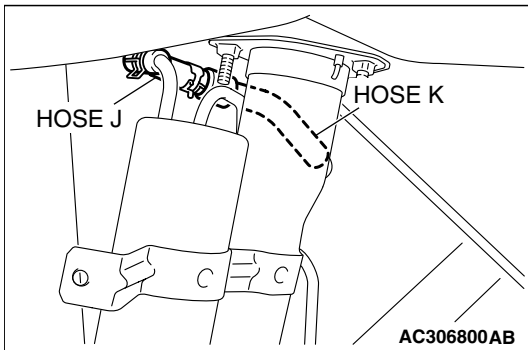
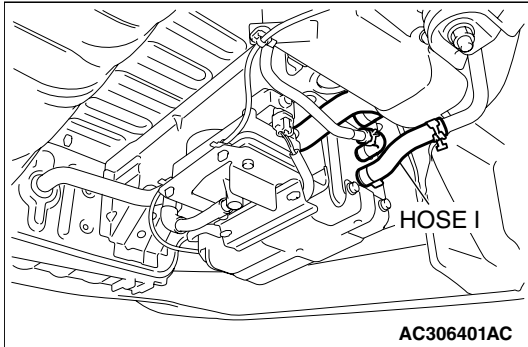

STEP 8. Check for leaks in evaporative emission hoses I through K.

- (1) Remove the fuel tank filler tube protector (Refer to GROUP 13C, Fuel Tank P.13C-10).
- (2) Use a hand vacuum pump to test each hose from hose I to hose K.

Q: Do the hoses hold vacuum?

YES : Go to Step 9.

NO : Replace any damaged hose. Then go to Step 15.

STEP 9. Test check valve.

- (1) Check valve is a one-way check valve.

- (2) Check valve should allow air to flow in only one direction.

Q: Does check valve allow air to pass in one direction only?

YES : Go to Step 10.

NO : Replace check valve, and reinstall the fuel tank filler tube protector (Refer to GROUP 13C, Fuel Tank P.13C-10). Then go to Step 15.

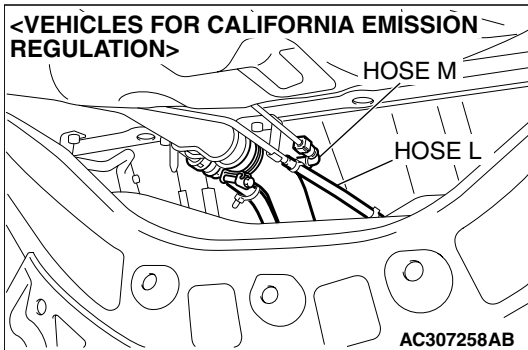
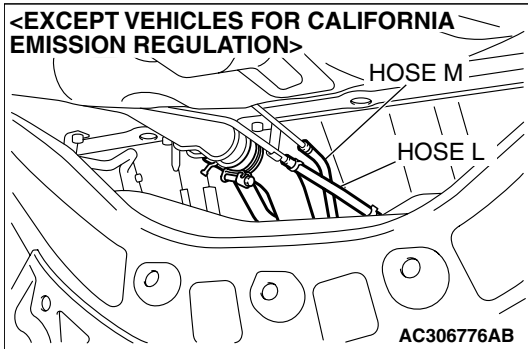

STEP 10. Check for leaks in evaporative emission hoses L and M.

Use a hand vacuum pump to test each hose L and M.

Q: Do the hoses hold vacuum?

YES : Go to Step 11.

NO : Replace any damaged hose. Then go to Step 15.

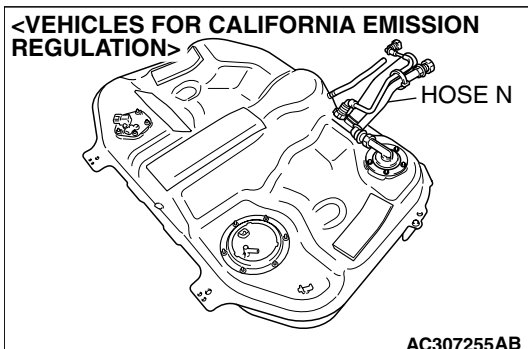
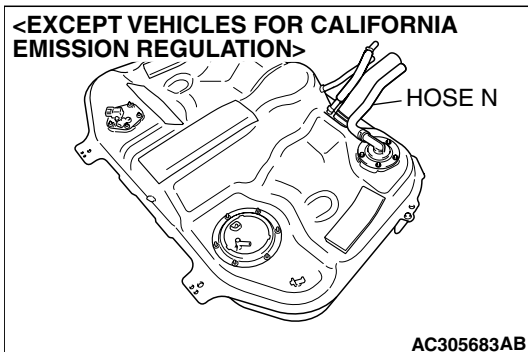

STEP 11. Check for leaks in evaporative emission hose N.

(1) Remove the fuel tank assembly (Refer to GROUP 13C, Fuel Tank [P.13C-10](#)).

(2) Use the hand vacuum pump to check the hose N.

Q: Is the hose hold vacuum?

YES : Go to Step 12.

NO : Replace the hose and reinstall the fuel tank assembly (Refer to GROUP 13C, Fuel Tank [P.13C-10](#)). Then go to Step 15.

<EXCEPT VEHICLES FOR CALIFORNIA
EMISSION REGULATION>

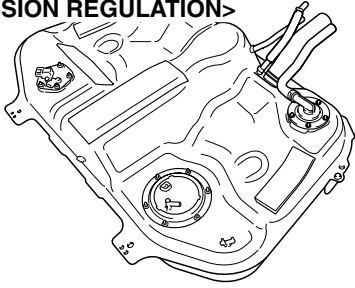

AC305683AD

<VEHICLES FOR CALIFORNIA EMISSION
REGULATION>

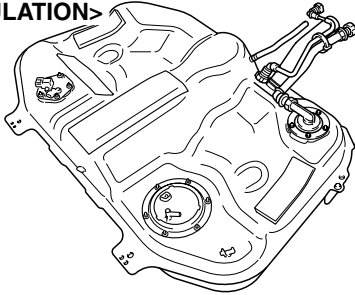

AC307255AC

STEP 12. Check for leaks in the fuel tank.

(1) Visually check for cracks or other leaks in the fuel tank.

NOTE: Carefully check the fuel pump module and the fuel tank differential pressure sensor installation in the fuel tank.

<EXCEPT VEHICLES FOR CALIFORNIA EMISSION REGULATION>

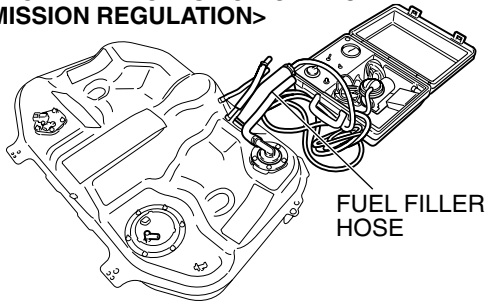

AC305684AD

- (2) Connect the evaporative emission system pressure pump (Miller number 6872A) to the fuel filler hose.

<VEHICLES FOR CALIFORNIA EMISSION REGULATION>

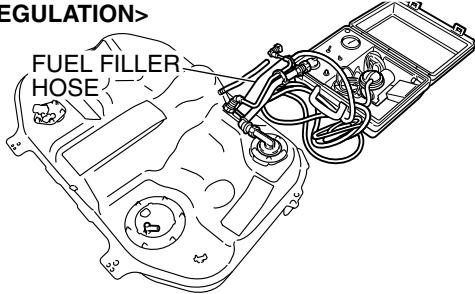

AC307256AB

<EXCEPT VEHICLES FOR CALIFORNIA EMISSION REGULATION>

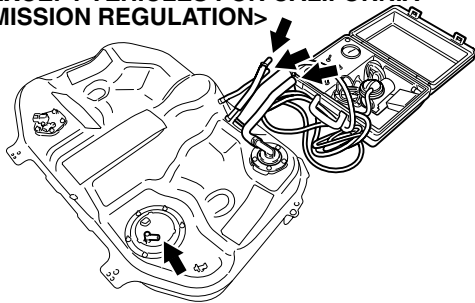

AC305684AE

- (3) Plug the hose and the nipple shown in the illustration.
NOTE: If these items are not securely plugged now, the fuel could leak in the next step.
- (4) Pressurize the fuel tank with the evaporative emission system pressure pump.
- (5) In the pressurized state, check for leaks by applying a soapy water solution to each section and look for bubbles.

Q: Are any leaks found?

YES <When there is a leak from the attachment points of the fuel pump module, fuel tank differential pressure sensor, fuel level sensor (sub) or leveling valve.> :

Reassemble the leaked parts and check again that there are no leaks. Then reinstall the fuel tank (Refer to GROUP 13C, Fuel Tank P.13C-10). Then go to Step 15 .

YES <When there is a leak from the fuel tank.> : Replace the fuel tank (Refer to GROUP 13C, Fuel Tank P.13C-10). Go to Step 15.

NO : When there is no leak, reinstall the fuel tank (Refer to GROUP 13C, Fuel Tank P.13C-10). Then go to Step 14.

<VEHICLES FOR CALIFORNIA EMISSION REGULATION>

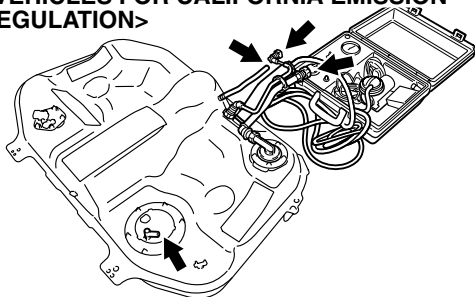

AC307256AC

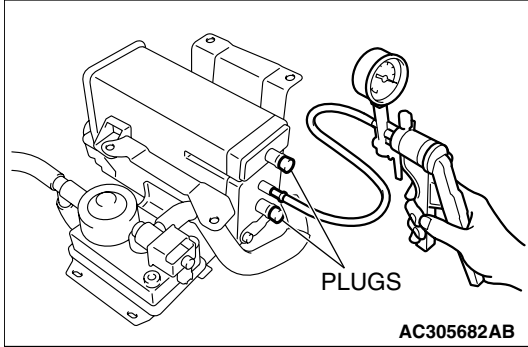
**STEP 13. Check the evaporative emission canister for vacuum leaks.**

- (1) Remove the evaporative emission canister (Refer to GROUP 17, Evaporative Emission Canister and Fuel Tank Pressure Relief Valve [P.17-95](#)).
- (2) Connect a hand vacuum pump to the evaporative emission canister and plug the other nipples.
- (3) Apply a pressure on the hand vacuum pump, and confirm that air is maintained.
- (4) Disconnect the hand vacuum pump and remove the plugs, and then install the evaporative emission canister (Refer to GROUP 17, Evaporative Emission Canister and Fuel Tank Pressure Relief Valve [P.17-95](#)).

Q: Is the evaporative emission canister in good condition?

YES : Go to Step 14.

NO : Replace the evaporative emission canister (Refer to GROUP 17, Evaporative Emission Canister and Fuel Tank Pressure Relief Valve [P.17-95](#)). Then go to Step 15 .

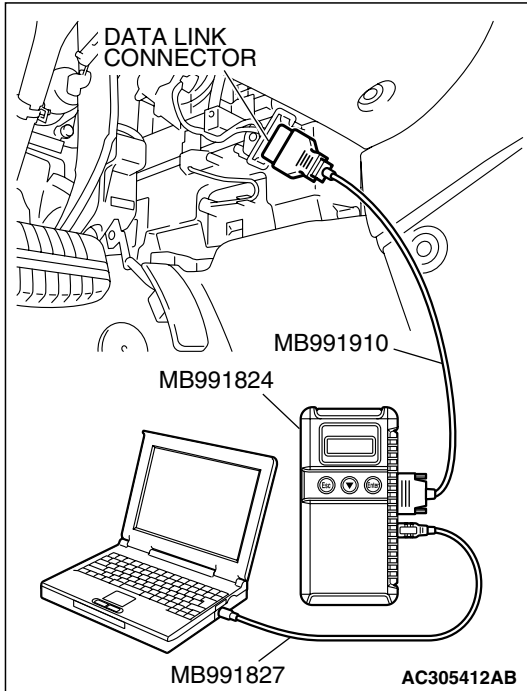

STEP 14. Using scan tool MB991958, check the evaporative emission system monitor test.

⚠ CAUTION

- To prevent damage to scan tool MB991958, always turn the ignition switch to the "LOCK" (OFF) position before connecting or disconnecting scan tool MB991958.
- During this test, the PCM automatically increases the engine speed to 1,600 r/min or greater. Check that the transaxle is set to the "P" position.

- (1) Connect scan tool MB991958 to the data link connector.
- (2) Turn the ignition switch to the "ON" position.
- (3) Erase the DTCs using scan tool MB991958.
- (4) Check that the fuel cap is securely closed (Tighten until three clicks are heard).
- (5) Start the engine.
- (6) Select "System Test."
- (7) Select "Evap Leak Mon."
- (8) During the test, keep the accelerator pedal at the idle position.
- (9) Keep the engine speed and engine load within the specified range. When the monitor test starts, the "In Progress" item on scan tool MB991958 will change from "NO" to "YES."
- (10) Turn the ignition switch to the "LOCK" (OFF) position. Disconnect scan tool MB991958.

Q: Is "Evap Leak Mon. Completed. Test Failed and DTCs Set" displayed on scan tool MB991958?

YES : Replace the PCM (Refer to [P.13A-1140](#)). Then go to Step 15 .

NO <"Evap Leak Mon. Completed. Test Passed" is displayed on scan tool MB991958.> : The evaporative emission system is working properly at this time. Go to Step 15 .

NO <"Evap Leak Mon. Discontinued. Retest again from the first" is displayed on scan tool MB991958.> : The EVAP monitor has been interrupted during the test. Turn the ignition switch to the "LOCK" (OFF) position once, and repeat the monitoring from Step 14.

STEP 15. Perform the OBD-II drive cycle.

- (1) Confirm the repair by performing the appropriate drive cycle (Refer to Diagnostic Function – OBD-II Drive Cycle – Procedure 1 – Evaporative Emission System Leak Monitor [P.13A-6](#)).
- (2) Read the DTC.

Q: Is DTC P0442 set?

YES : Repeat the troubleshooting from Step 1 .

NO : The procedure is complete.

DTC P0443: Evaporative Emission Control System Purge Control Valve Circuit

Evaporative Emission Purge Solenoid Circuit

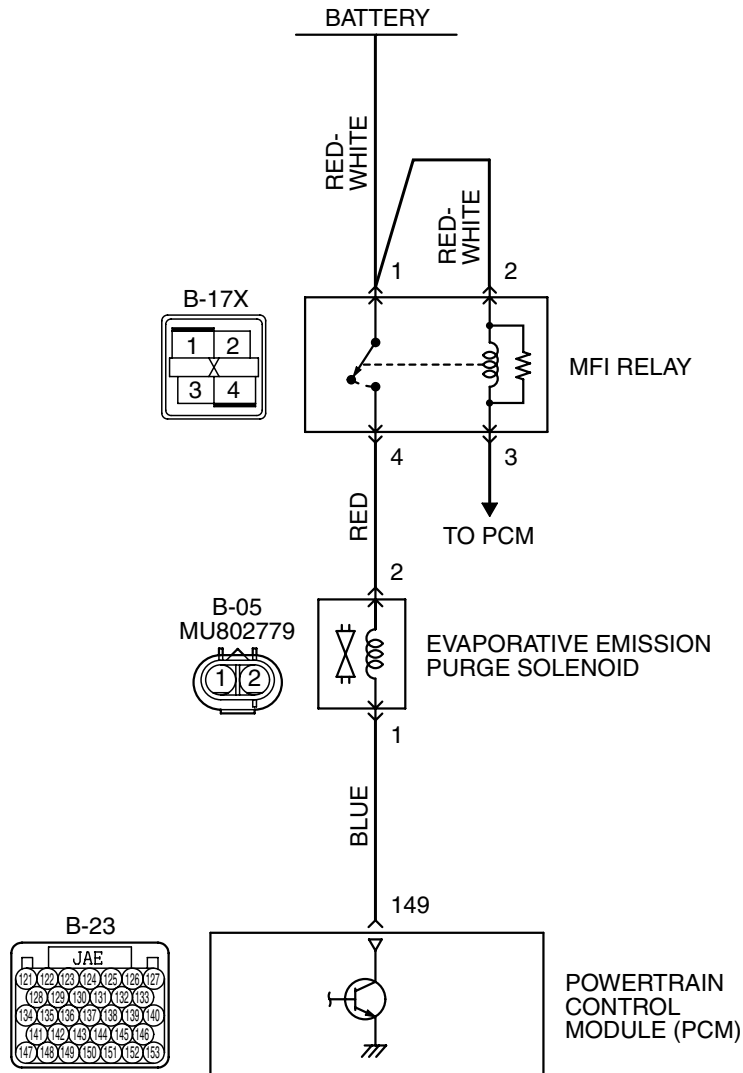

AK400892

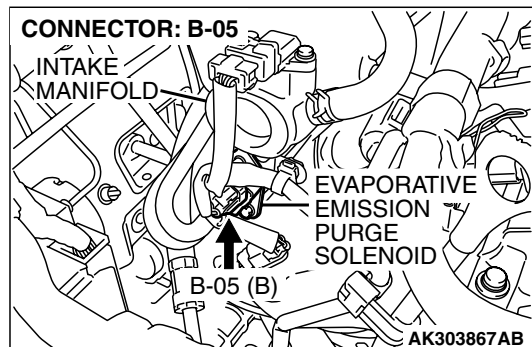
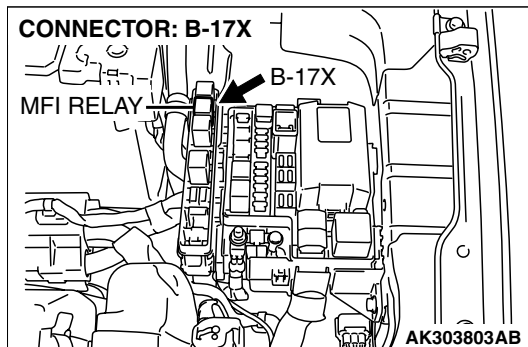

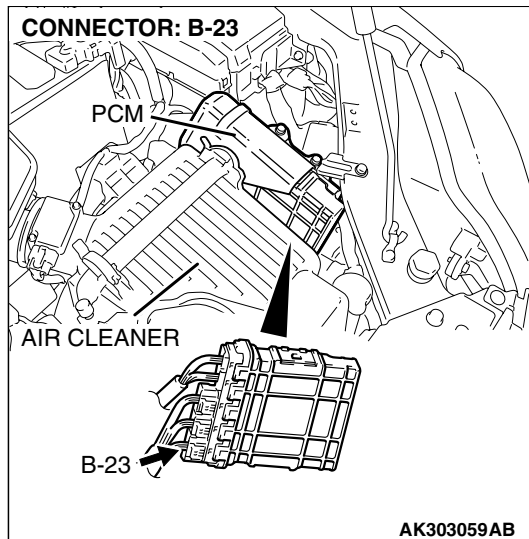

CIRCUIT OPERATION

- The evaporative emission purge solenoid power is supplied from the MFI relay (terminal No. 4).
- The PCM controls ground evaporative emission purge solenoid by turning the power transistor in the PCM "ON" and "OFF".

TECHNICAL DESCRIPTION

- To judge if there is open circuit in the evaporative emission purge solenoid drive circuit, the PCM measures the surge voltage of the evaporative emission ventilation solenoid coil.

DESCRIPTIONS OF MONITOR METHODS

Off-surge does not occur after solenoid is operated from on to off.

MONITOR EXECUTION

Continuous

MONITOR EXECUTION CONDITIONS (Other monitor and Sensor)

Other Monitor (There is no temporary DTC stored in memory for the item monitored below)

- Not applicable

Sensor (The sensor below is determined to be normal)

- Not applicable

DTC SET CONDITIONS

Logic Flow Chart

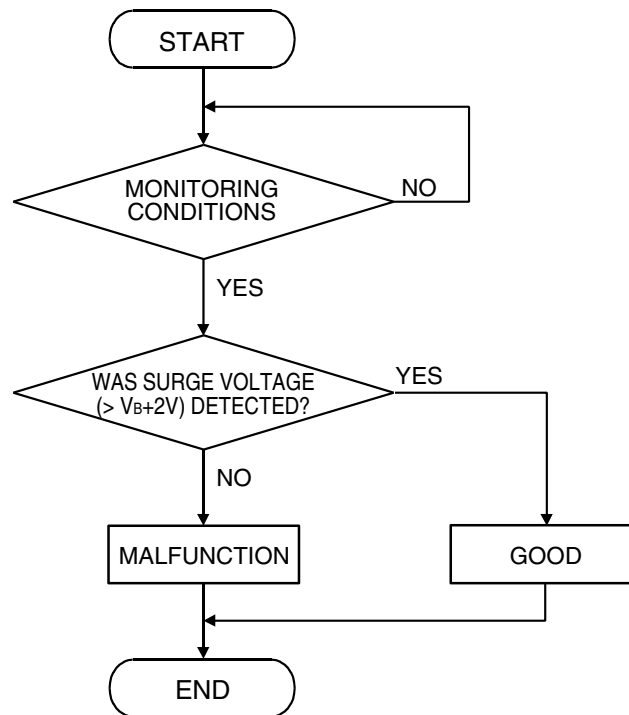

AK302039

Check Conditions

- Engine is being cranked.
- Battery positive voltage is between 10 and 16.5 volts.

Judgment Criteria

- The evaporative emission purge solenoid coil surge voltage (battery positive voltage + 2 volts) is not detected for 0.2 second.
- The PCM monitors for this condition once during the drive cycle.

Check Conditions

- Battery positive voltage is between 10 and 16.5 volts.
- ON duty cycle of the evaporative emission purge solenoid is between 10 and 90 percent.
- Evaporative emission ventilation solenoid is off.
- More than 1 second has elapsed after the above mentioned conditions have been met.

Judgment Criteria

- The evaporative emission purge solenoid coil surge voltage (battery positive voltage + 2 volts) is not detected for 1 second after the evaporative emission purge solenoid is turned off.

OBD-II DRIVE CYCLE PATTERN

Refer to Diagnostic Function – OBD-II Drive Cycle – Procedure 6 – Other Monitor [P.13A-6](#).

TROUBLESHOOTING HINTS (The most likely causes for this code to be set are:)

- Evaporative emission purge solenoid failed.
- Open or shorted evaporative emission purge solenoid circuit, harness damage, or connector damage.
- PCM failed.

DIAGNOSIS

Required Special Tools:

- MB991958: Scan tool (MUT-III Sub Assembly)
 - MB991824: V.C.I.
 - MB991827: USB Cable
 - MB991910: Main Harness A
- MB991923: Power Plant ECU Check Harness

STEP 1. Using scan tool MB991958, check actuator test item 08: Evaporative Emission Purge Solenoid.

⚠ CAUTION

To prevent damage to scan tool MB991958, always turn the ignition switch to the "LOCK" (OFF) position before connecting or disconnecting scan tool MB991958.

- (1) Connect scan tool MB991958 to the data link connector.
- (2) Turn the ignition switch to the "ON" position.
- (3) Set scan tool MB991958 to the actuator test mode for item 08, Evaporative emission purge solenoid.
 - An operation sound should be heard and vibration should be felt when the evaporative emission purge solenoid is operated.
- (4) Turn the ignition switch to the "LOCK" (OFF) position.

Q: Is the solenoid operating properly?

YES : It can be assumed that this malfunction is intermittent. Refer to GROUP 00, How to Use Troubleshooting/Inspection Service Points – How Cope with Intermittent Malfunctions [P.00-14](#).

NO : Go to Step 2.

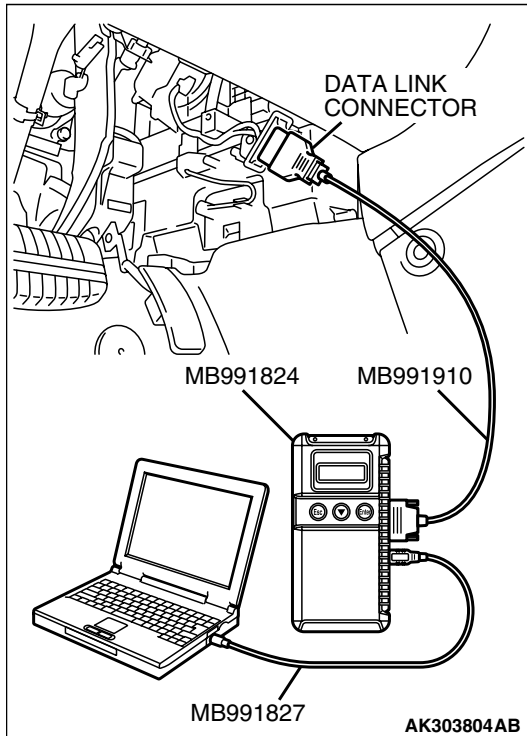

STEP 2 Check harness connector B-05 at the evaporative emission purge solenoid for damage.

Q: Is the harness connector in good condition?

YES : Go to Step 3.

NO : Repair or replace it. Refer to GROUP 00E, Harness Connector Inspection [P.00E-2](#). Then go to Step 12.

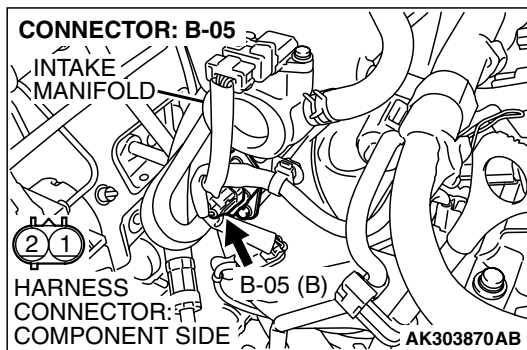

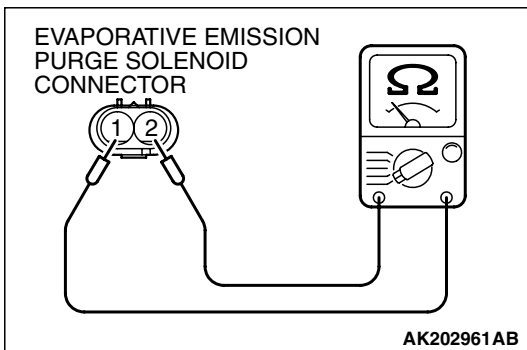
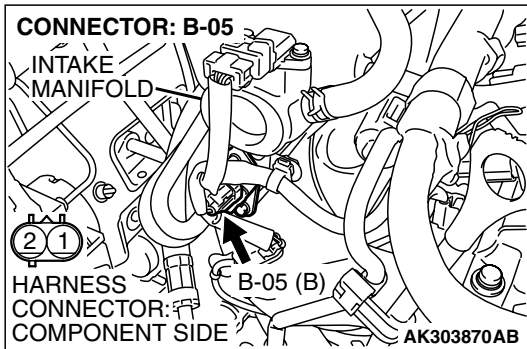
**STEP 3 Check the evaporative emission purge solenoid.**

- (1) Disconnect the evaporative emission purge solenoid connector B-05.

- (2) Measure the resistance between evaporative emission purge solenoid side connector terminal No. 1 and No. 2.

Standard value: 30 – 34 ohms [at 20°C (68°F)]

Q: Is the measured resistance between 30 and 34 ohms [at 20°C (68°F)]?

YES : Go to Step 4.

NO : Replace the evaporative emission purge solenoid.
Then go to Step 12.

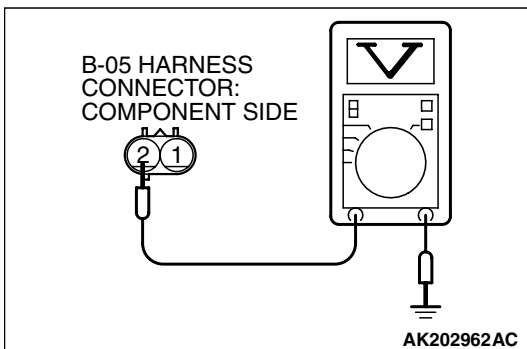
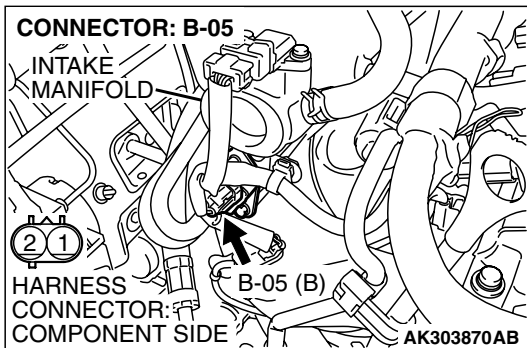
**STEP 4. Measure the power supply voltage at evaporative emission purge solenoid harness side connector B-05.**

- (1) Disconnect the connector B-05 and measure at the harness side.
(2) Turn the ignition switch to the "ON" position.

- (3) Measure the voltage between terminal No. 2 and ground.
• Voltage should be battery positive voltage.
(4) Turn the ignition switch to the "LOCK" (OFF) position.

Q: Is battery positive voltage (approximately 12 volts) present?

YES : Go to Step 6.

NO : Go to Step 5.

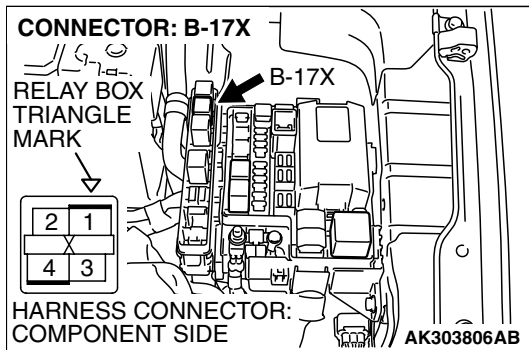

STEP 5. Check harness connector B-17X at MFI relay for damage.

Q: Is the harness connector in good condition?

- YES :** Repair harness wire between MFI relay connector B-17X (terminal No. 4) and evaporative emission purge solenoid connector B-05 (terminal No. 2) because of open circuit or short circuit to ground. Then go to Step 12.
- NO :** Repair or replace it. Refer to GROUP 00E, Harness Connector Inspection [P.00E-2](#). Then go to Step 12.

STEP 6. Measure the power supply voltage at PCM connector B-23 by using power plant ECU check harness special tool MB991923.

- (1) Disconnect the all PCM connectors and connect power plant ECU check harness special tool MB991923 between the separated connectors.
- (2) Turn the ignition switch to the "ON" position.

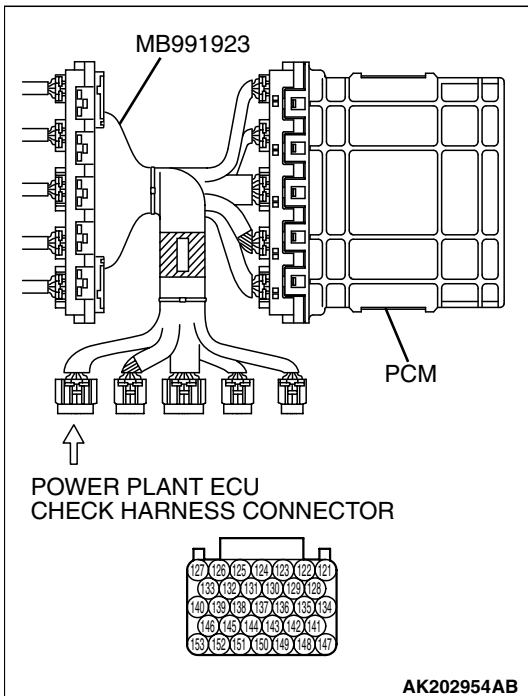
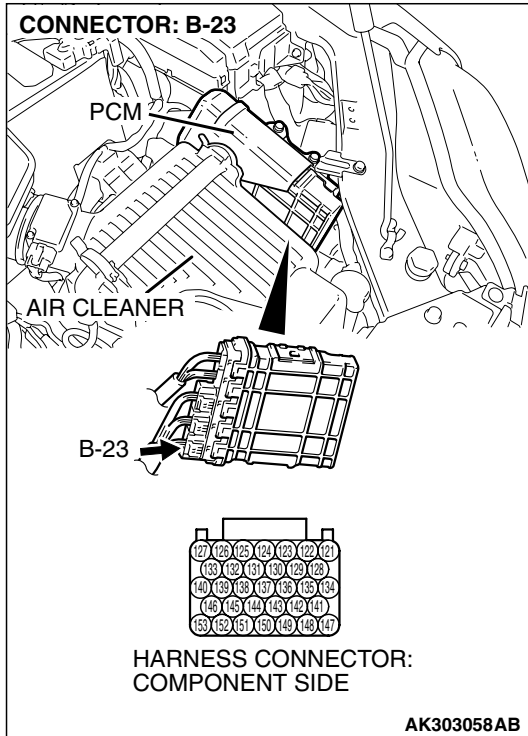

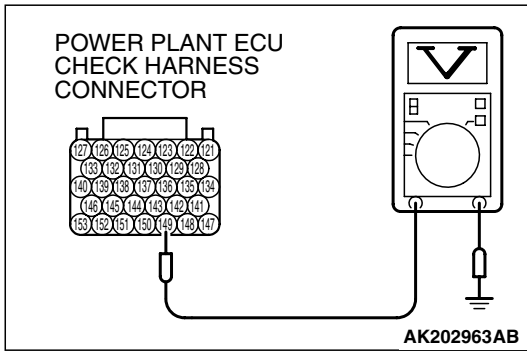

- (3) Measure the voltage between terminal No. 149 and ground.
 - Voltage should be battery positive voltage.
- (4) Turn the ignition switch to the "LOCK" (OFF) position.

Q: Is battery positive voltage (approximately 12 volts) present?

- YES** : Go to Step 9.
NO : Go to Step 7.

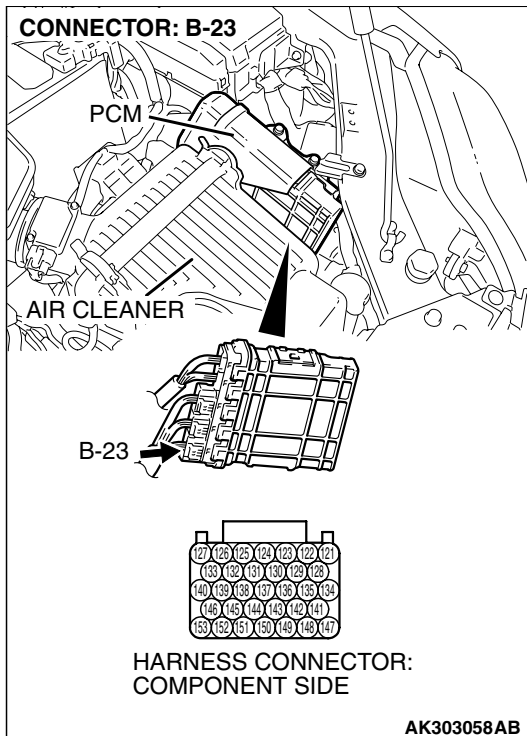

STEP 7. Check harness connector B-23 at PCM for damage.

Q: Is the harness connector in good condition?

- YES** : Go to Step 8.
NO : Repair or replace it. Refer to GROUP 00E, Harness Connector Inspection [P.00E-2](#). Then go to Step 12.

STEP 8. Check for open circuit and short circuit to ground between evaporative emission purge solenoid connector B-05 (terminal No. 1) and PCM connector B-23 (terminal No. 149).

Q: Is the harness wire in good condition?

YES : Replace the PCM. Then go to Step 12.

NO : Repair it. Then go to Step 12.

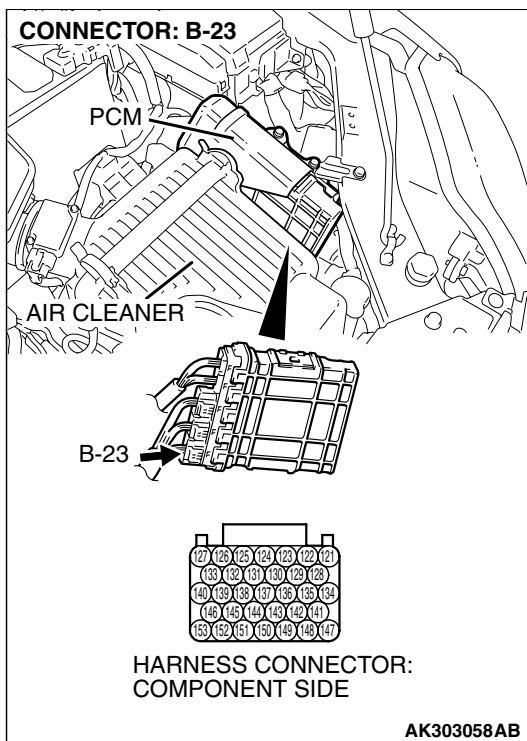
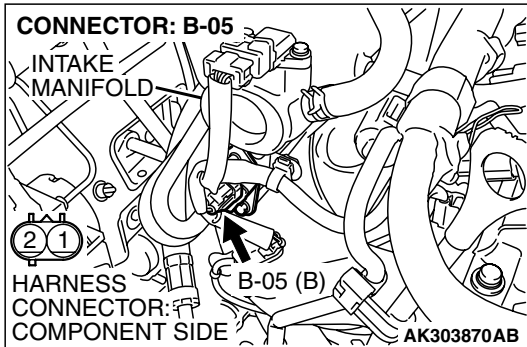

STEP 9. Check harness connector B-23 at PCM for damage.

Q: Is the harness connector in good condition?

YES : Go to Step 10.

NO : Repair or replace it. Refer to GROUP 00E, Harness Connector Inspection [P.00E-2](#). Then go to Step 12.

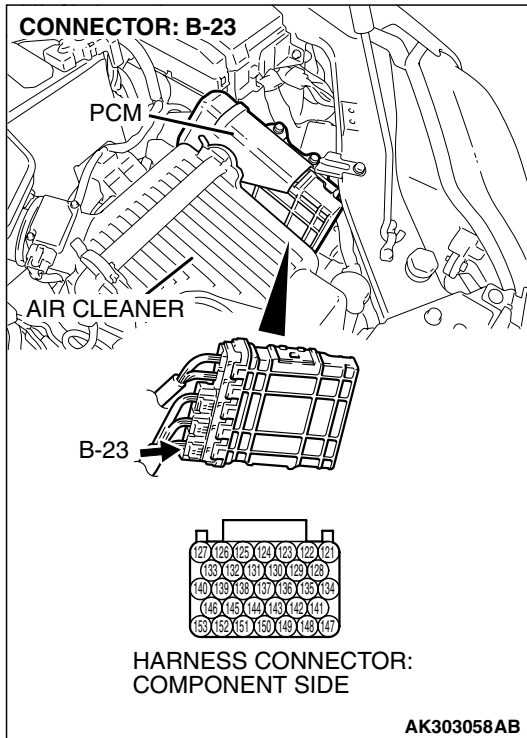

STEP 10. Check for harness damage between MFI relay connector B-17X (terminal No. 4) and evaporative emission purge solenoid connector B-05 (terminal No. 2).

Q: Is the harness wire in good condition?

YES : Go to Step 11.

NO : Repair it. Then go to Step 12.

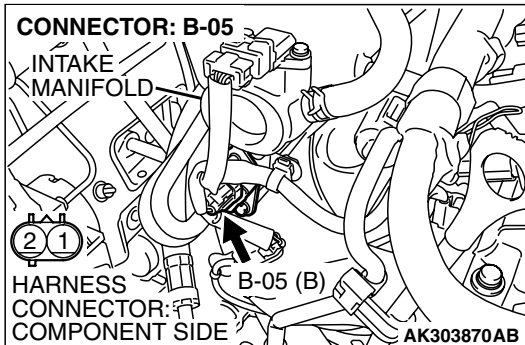
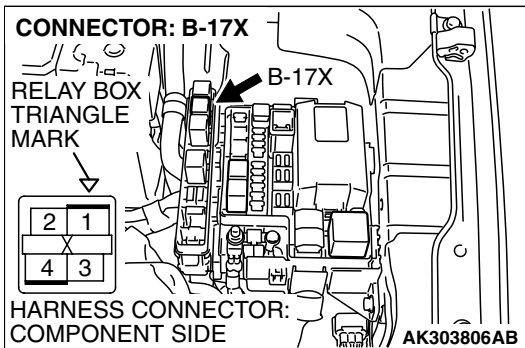

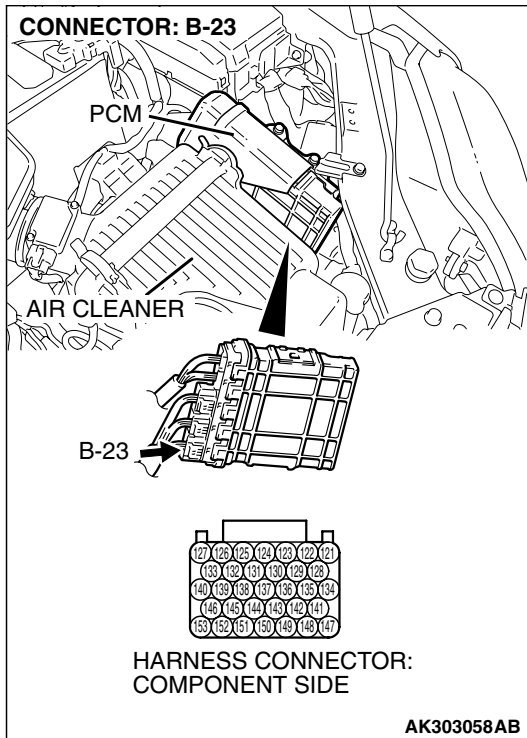
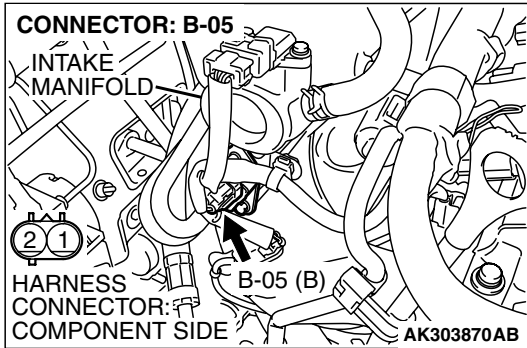

STEP 11. Check for harness damage between evaporative emission purge solenoid connector B-05 (terminal No. 1) and PCM connector B-23 (terminal No. 149).

Q: Is the harness wire in good condition?

- YES :** Replace the PCM. Then go to Step 12.
- NO :** Repair it. Then go to Step 12.

STEP 12. Test the OBD-II drive cycle.

- (1) Carry out a test drive with the drive cycle pattern. Refer to Diagnostic Function – OBD-II Drive Cycle – Procedure 6 – Other Monitor [P.13A-6](#).
- (2) Check the diagnostic trouble code (DTC).

Q: Is DTC P0443 set?

- YES :** Retry the troubleshooting.
- NO :** The inspection is complete.

DTC P0446: Evaporative Emission Control System Vent Control Circuit

Evaporative Emission Ventilation Solenoid Circuit

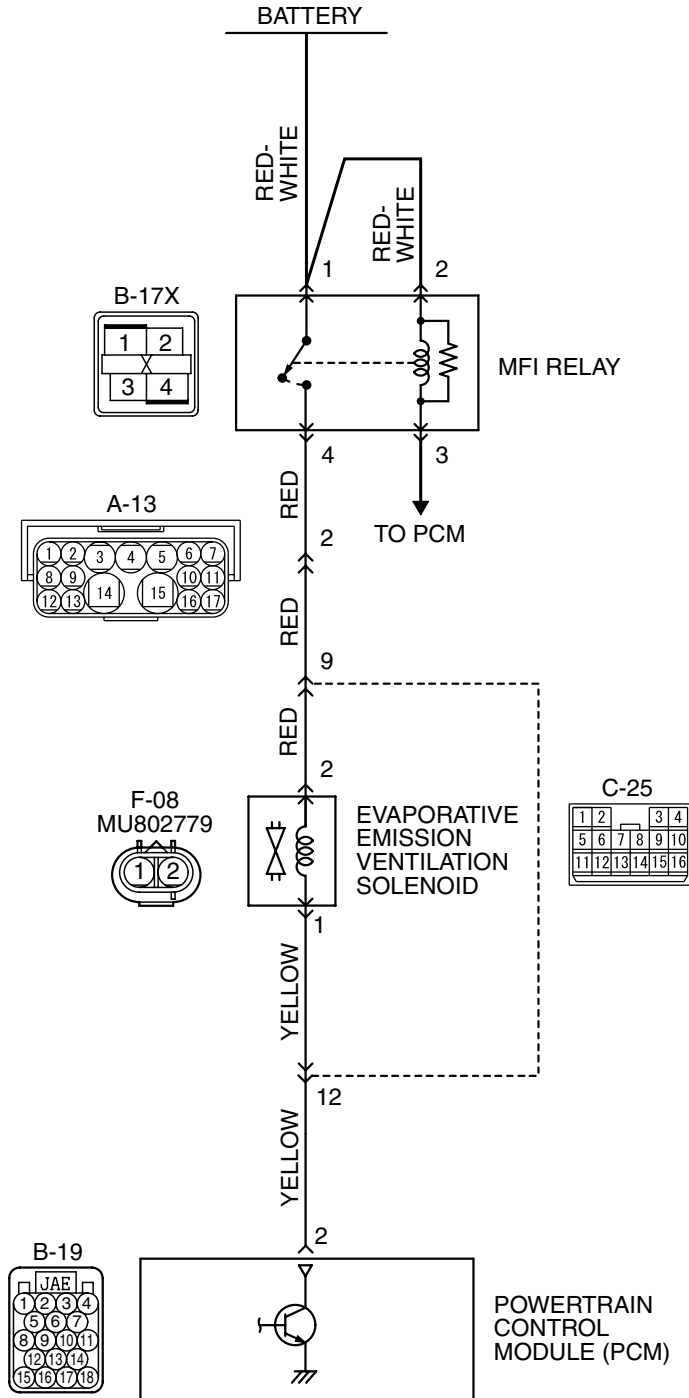

AK400893

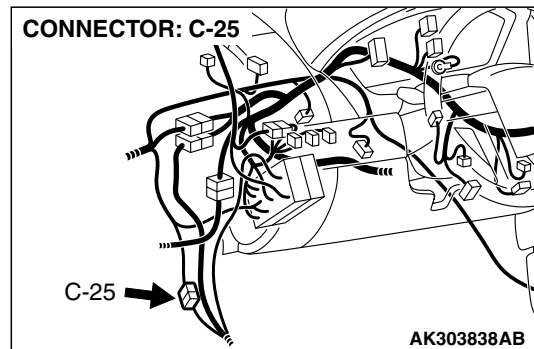
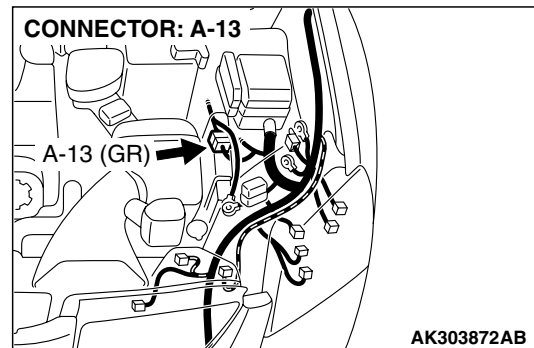
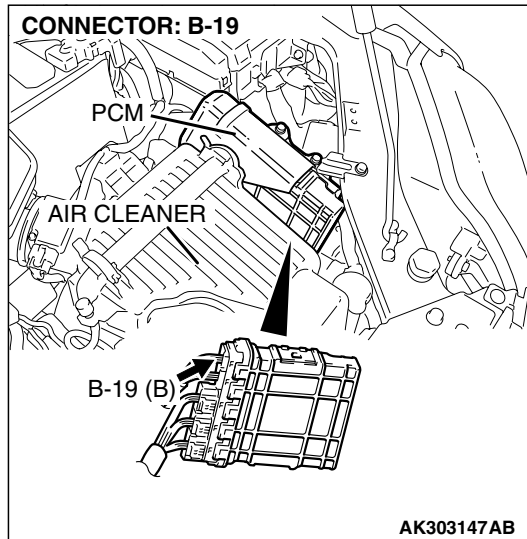
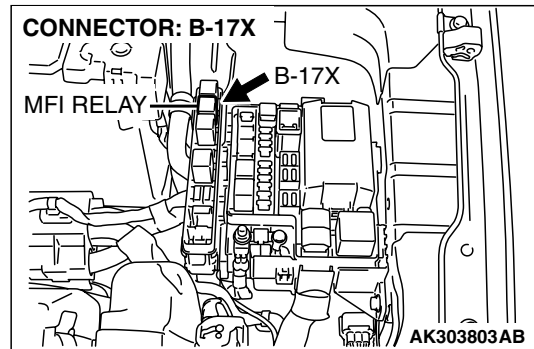
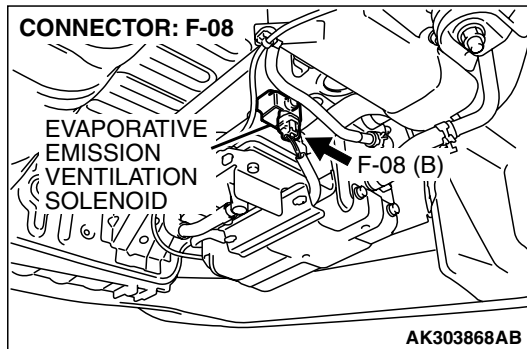

CIRCUIT OPERATION

- The evaporative emission ventilation solenoid power is supplied from the MFI relay (terminal No. 4).
- The PCM controls the evaporative emission ventilation solenoid ground by turning the power transistor in the PCM ON and OFF.

TECHNICAL DESCRIPTION

- To judge if there is open circuit in the evaporative emission ventilation solenoid drive circuit, PCM measures the surge voltage of the evaporative emission ventilation solenoid coil.
- The PCM drives the evaporative emission ventilation solenoid. After the solenoid is turned off, the PCM will check if the solenoid coil produces a surge voltage (battery positive voltage + 2 volts).

DESCRIPTIONS OF MONITOR METHODS

Off-surge does not occur after solenoid is operated on to off.

MONITOR EXECUTION

Continuous

MONITOR EXECUTION CONDITIONS (Other monitor and Sensor)

Other Monitor (There is no temporary DTC stored in memory for the item monitored below)

- Not applicable

Sensor (The sensor below is determined to be normal)

- Not applicable

DTC SET CONDITIONS

Logic Flow Chart

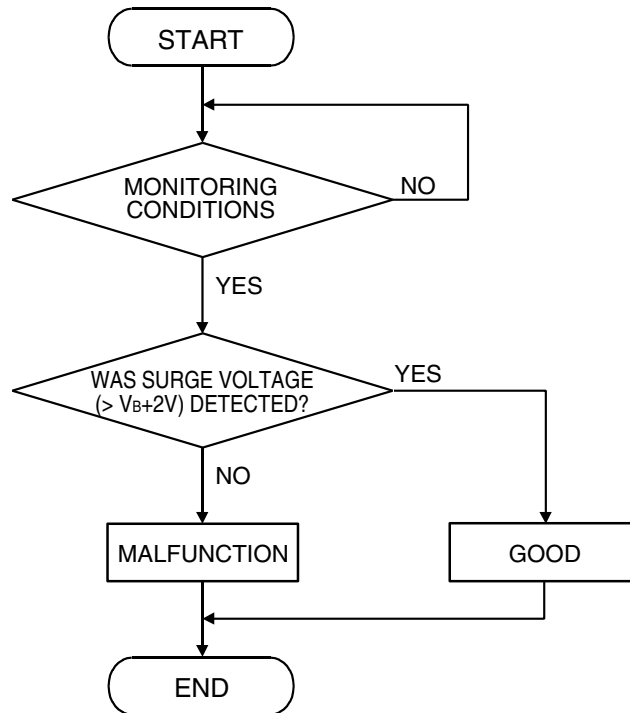

AK302039

Check Conditions

- Engine is being cranked.
- Battery positive voltage is between 10 and 16.5 volts.

Judgment Criteria

- The evaporative emission ventilation solenoid coil surge voltage (battery positive voltage + 2 volts) is not detected for 0.2 second.
- The PCM monitors for this condition once during the drive cycle.

Check Conditions

- Battery positive voltage is at between 10 and 16.5 volts.
- ON duty cycle of the evaporative emission purge solenoid is 0 percent.
- Evaporative emission ventilation solenoid is ON.
- More than 1 second has elapsed after the above mentioned conditions have been met.

Judgment Criteria

- The evaporative emission ventilation solenoid coil surge voltage (battery positive voltage + 2 volts) is not detected for 1 second after the evaporative emission ventilation solenoid is turned OFF.

OBD-II DRIVE CYCLE PATTERN

Refer to Diagnostic Function – OBD-II Drive Cycle – Procedure 6 – Other Monitor [P.13A-6](#).

TROUBLESHOOTING HINTS (The most likely causes for this code to be set are:)

- Evaporative emission ventilation solenoid failed.
- Open or shorted evaporative emission ventilation solenoid circuit, harness damage, or connector damage.
- PCM failed.

DIAGNOSIS**Required Special Tools:**

- MB991958: Scan tool (MUT-III Sub Assembly)
 - MB991824: V.C.I.
 - MB991827: USB Cable
 - MB991910: Main Harness A
- MB991923: Power Plant ECU Check Harness

STEP 1. Using scan tool MB991958, check actuator test item 29: Evaporative Emission Ventilation Solenoid.

⚠ CAUTION

To prevent damage to scan tool MB991958, always turn the ignition switch to the "LOCK" (OFF) position before connecting or disconnecting scan tool MB991958.

- (1) Connect scan tool MB991958 to the data link connector.
- (2) Turn the ignition switch to the "ON" position.
- (3) Set scan tool MB991958 to the actuator test mode for item 29, Evaporative emission ventilation solenoid.
 - An operation sound should be heard and vibration should be felt when the evaporative emission ventilation solenoid is operated.
- (4) Turn the ignition switch to the "LOCK" (OFF) position.

Q: Is the solenoid operating properly?

YES : It can be assumed that this malfunction is intermittent. Refer to GROUP 00, How to Use Troubleshooting/Inspection Service Points – How to Cope with Intermittent Malfunctions [P.00-14](#).

NO : Go to Step 2.

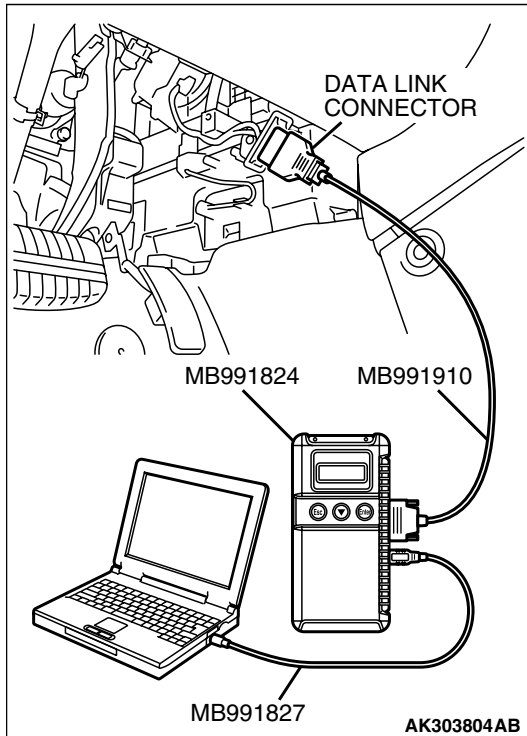

STEP 2. Check harness connector F-08 at the evaporative emission ventilation solenoid for damage.

Q: Is the harness connector in good condition?

YES : Go to Step 3.

NO : Repair or replace it. Refer to GROUP 00E, Harness Connector Inspection [P.00E-2](#). Then go to Step 12.

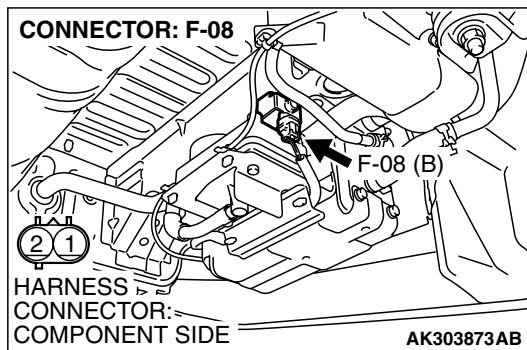

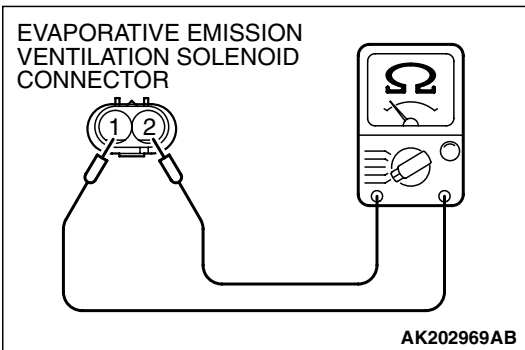
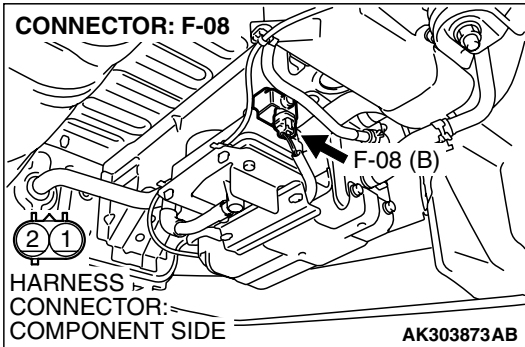

STEP 3. Check the evaporative emission ventilation solenoid.

- (1) Disconnect the evaporative emission ventilation solenoid connector F-08.

- (2) Measure the resistance between evaporative emission ventilation solenoid side connector terminal No. 1 and No. 2.

Standard value: 17 – 21 ohms [at 20°C (68°F)]

Q: Is the measured resistance between 17 and 21 ohms [at 20°C (68°F)]?

YES : Go to Step 4.

NO : Replace it. Then go to Step 12.

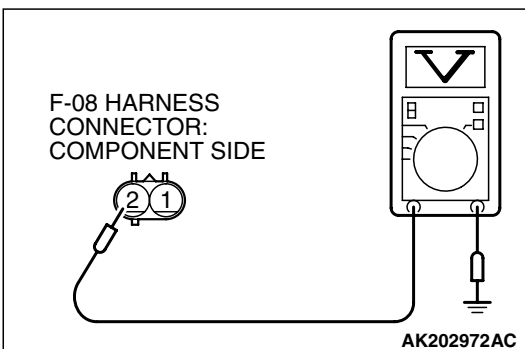
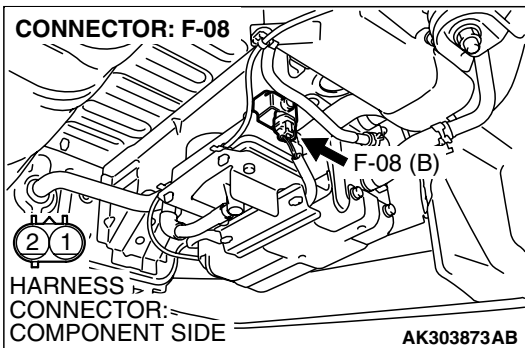

STEP 4. Measure the power supply voltage at evaporative emission ventilation solenoid harness side connector F-08.

- (1) Disconnect the connector F-08 and measure at the harness side.
- (2) Turn the ignition switch to the "ON" position.

- (3) Measure the voltage between terminal No. 2 and ground.
 - Voltage should be battery positive voltage.

- (4) Turn the ignition switch to the "LOCK" (OFF) position.

Q: Is battery positive voltage (approximately 12 volts) present?

YES : Go to Step 6.

NO : Go to Step 5.

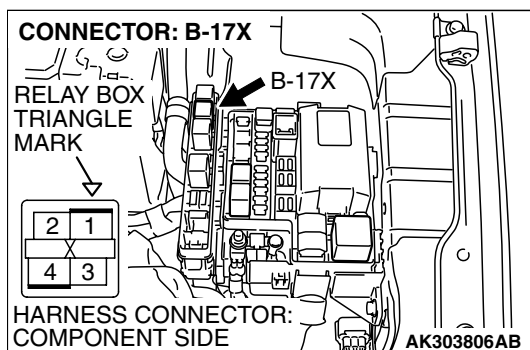

STEP 5. Check harness connector B-17X at MFI relay for damage.

Q: Is the harness connector in good condition?

YES : Check connectors A-13 and C-25 at intermediate connector for damage, and repair or replace as required. Refer to GROUP 00E, Harness Connector Inspection [P.00E-2](#). If intermediate connectors are in good condition, repair harness wire between MFI relay connector B-17X (terminal No. 4) and evaporative emission ventilation solenoid connector F-08 (terminal No. 2) because of open circuit or short circuit to ground. Then go to Step 12.

NO : Repair or replace it. Refer to GROUP 00E, Harness Connector Inspection [P.00E-2](#). Then go to Step 12.

STEP 6. Measure the power supply voltage at PCM connector B-19 by using power plant ECU check harness special tool MB991923.

- (1) Disconnect the all PCM connectors and connect power plant ECU check harness special tool MB991923 between the separated connectors.
- (2) Turn the ignition switch to the "ON" position.

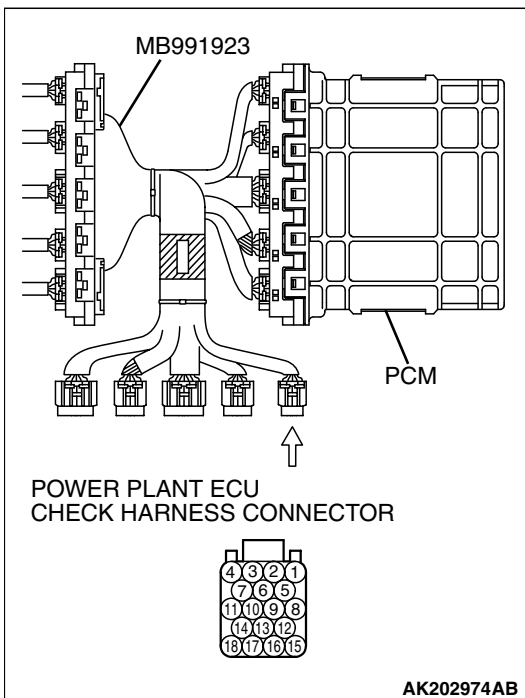
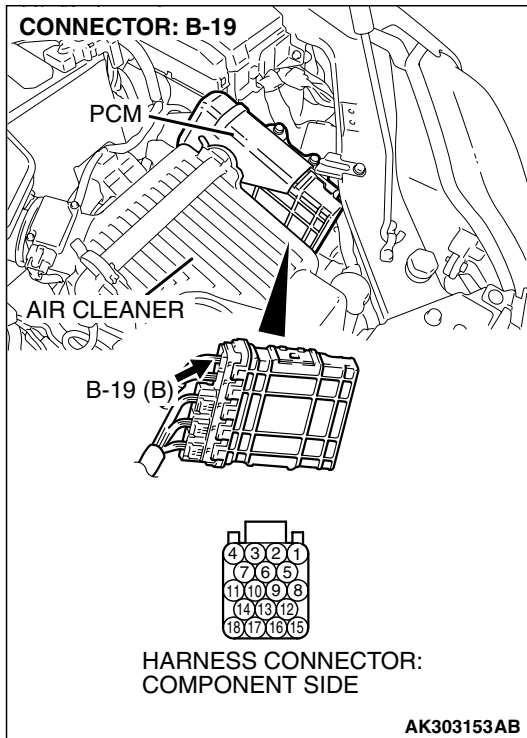

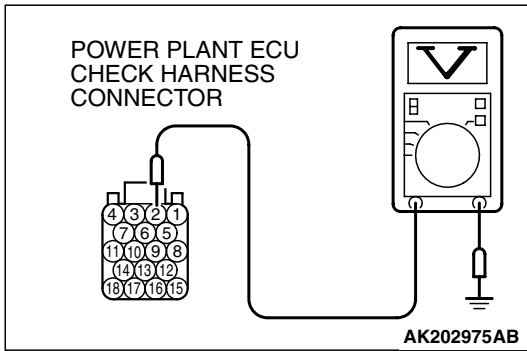

- (3) Measure the voltage between terminal No. 2 and ground.
 - Voltage should be battery positive voltage.
- (4) Turn the ignition switch to the "LOCK" (OFF) position.

Q: Is battery positive voltage (approximately 12 volts) present?

- YES :** Go to Step 9.
- NO :** Go to Step 7.

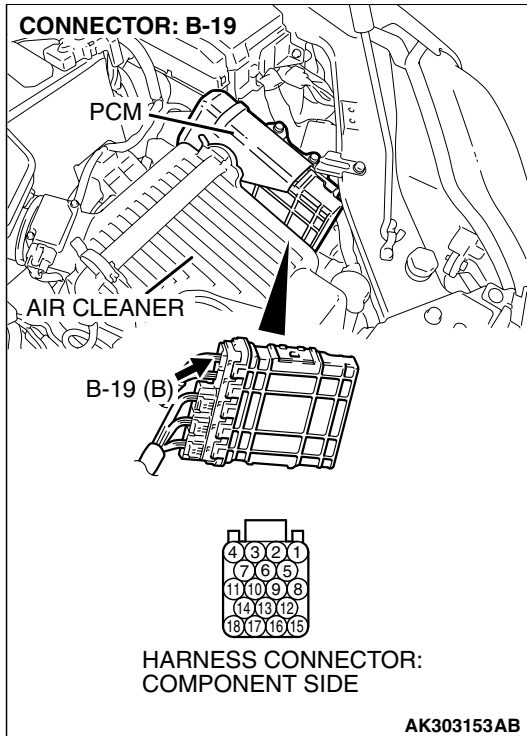

STEP 7. Check harness connector B-19 at PCM for damage.

Q: Is the harness connector in good condition?

- YES :** Go to Step 8.
- NO :** Repair or replace it. Refer to GROUP 00E, Harness Connector Inspection [P.00E-2](#). Then go to Step 12.

STEP 8. Check for open circuit and short circuit to ground between evaporative emission ventilation solenoid connector F-08 (terminal No. 1) and PCM connector B-19 (terminal No. 11).

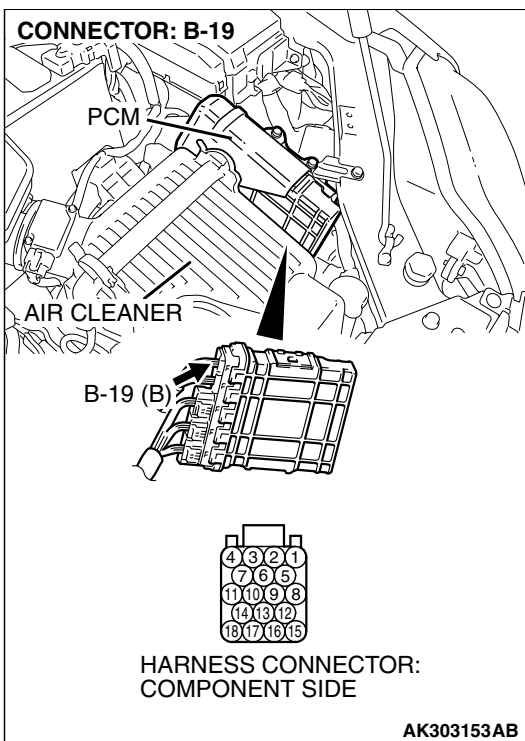
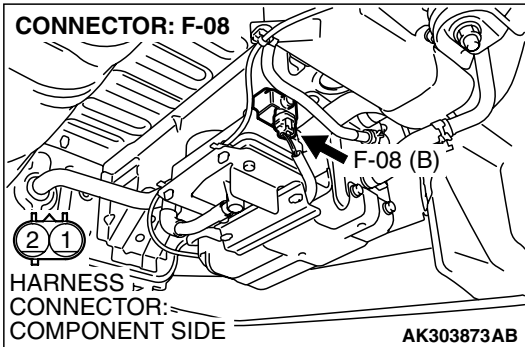

NOTE: Check harness after checking intermediate connector C-25. If intermediate connector is damaged, repair or replace it. Refer to GROUP 00E, Harness Connector Inspection P.00E-2. Then go to Step 12.

Q: Is the harness wire in good condition?

YES : Replace the PCM. Then go to Step 12.

NO : Repair it. Then go to Step 12.

STEP 9. Check harness connector B-19 at PCM for damage.

Q: Is the harness connector in good condition?

YES : Go to Step 10.

NO : Repair or replace it. Refer to GROUP 00E, Harness Connector Inspection [P.00E-2](#). Then go to Step 12.

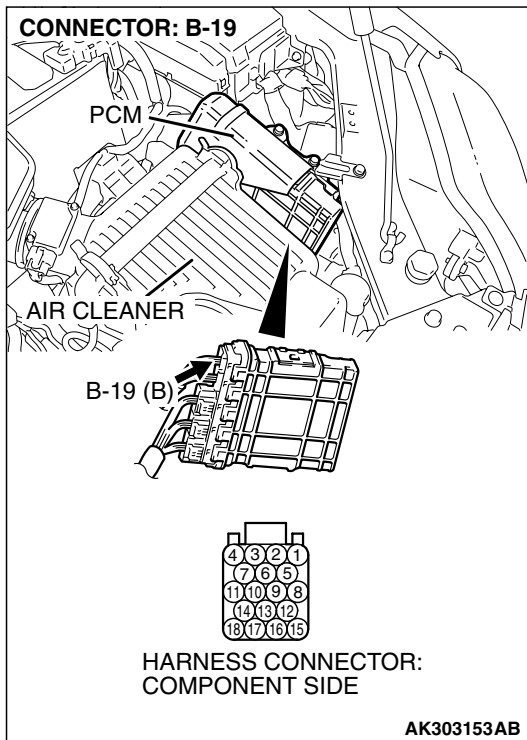

STEP 10. Check for harness damage between MFI relay connector B-17X (terminal No. 4) and evaporative emission ventilation solenoid connector F-08 (terminal No. 2).

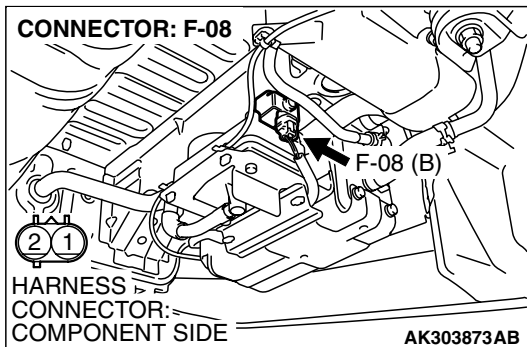
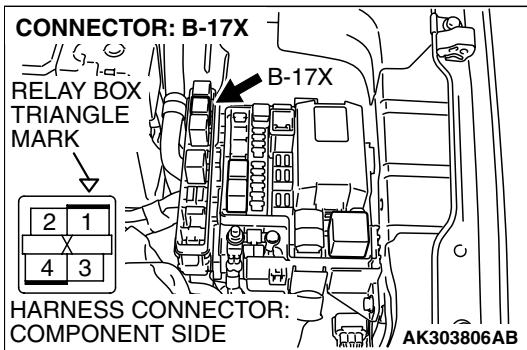

NOTE: Check harness after checking intermediate connectors A-13 and C-25. If intermediate connectors are damaged, repair or replace them. Refer to GROUP 00E, Harness Connector Inspection P.00E-2. Then go to Step 12.

Q: Is the harness wire in good condition?

YES : Go to Step 11.

NO : Repair it. Then go to Step 12.

STEP 11. Check for harness damage between evaporative emission ventilation solenoid connector F-08 (terminal No. 1) and PCM connector B-19 (terminal No. 2).

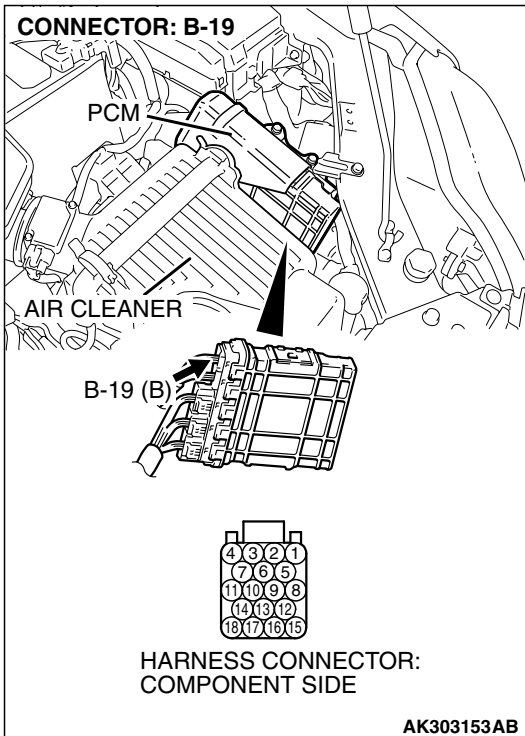
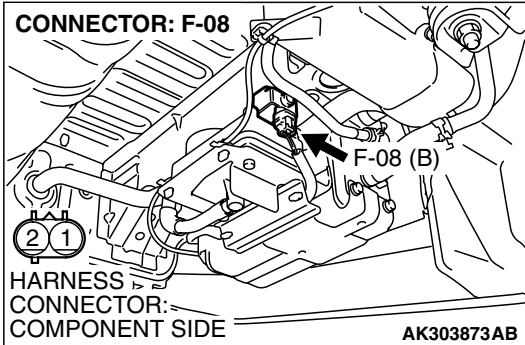

NOTE: Check harness after checking intermediate connector C-25. If intermediate connector is damaged, repair or replace it. Refer to GROUP 00E, Harness Connector Inspection P.00E-2. Then go to Step 12.

Q: Is the harness wire in good condition?

YES : Replace the PCM. Then go to Step 12.

NO : Repair it. Then go to Step 12.

STEP 12. Test the OBD-II drive cycle.

- (1) Carry out a test drive with the drive cycle pattern. Refer to Diagnostic Function – OBD-II Drive Cycle – Procedure 6 – Other Monitor P.13A-6.
- (2) Check the diagnostic trouble code (DTC).

Q: Is DTC P0446 set?

- YES** : Retry the troubleshooting.
NO : The inspection is complete.

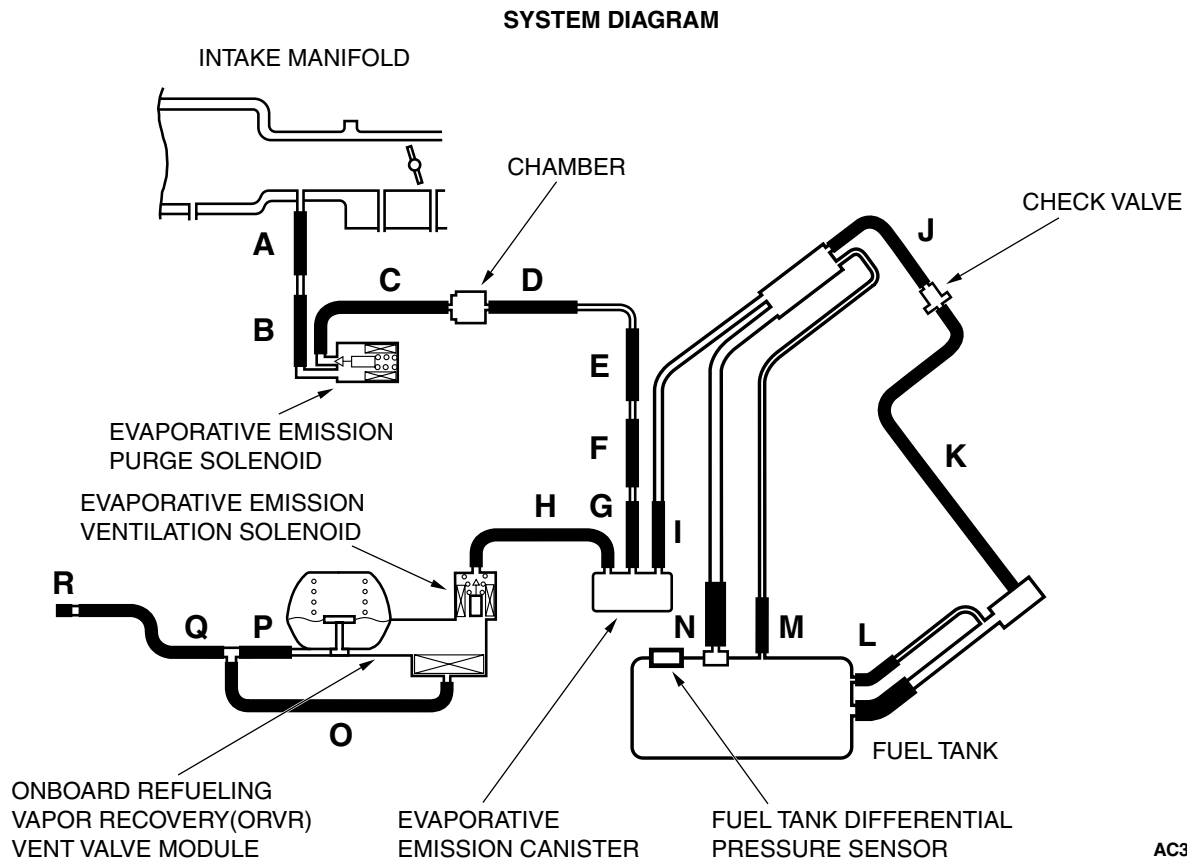
DTC P0450: Evaporative Emission System Pressure Sensor malfunction

Fuel Tank Differential Pressure Sensor Circuit

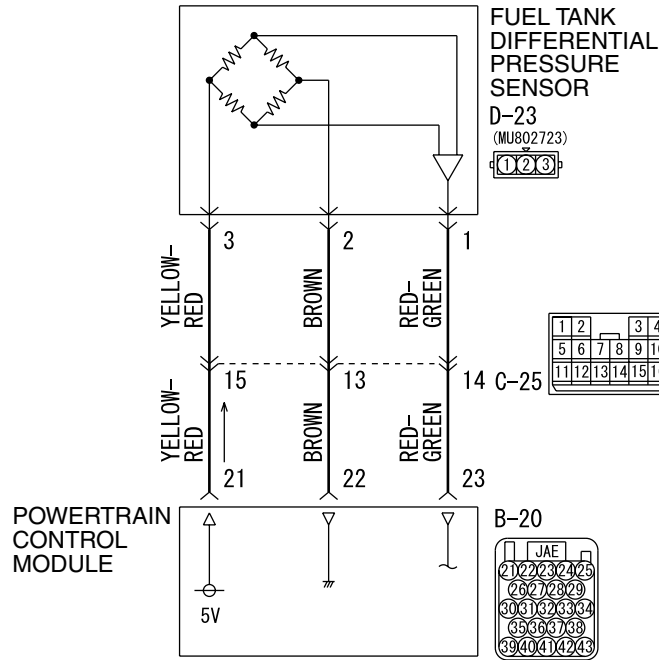

W4P13M02AA
AC306128

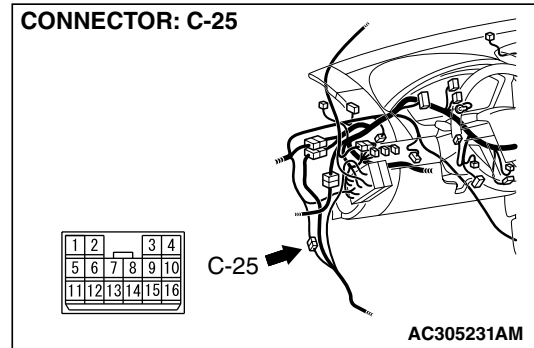
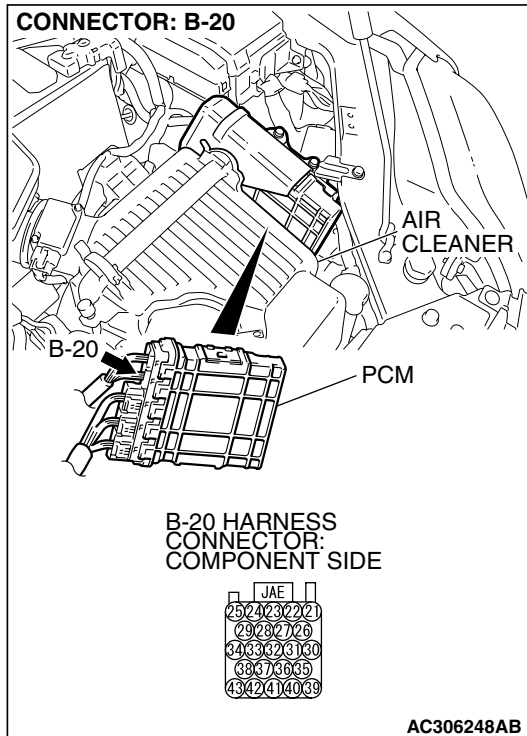

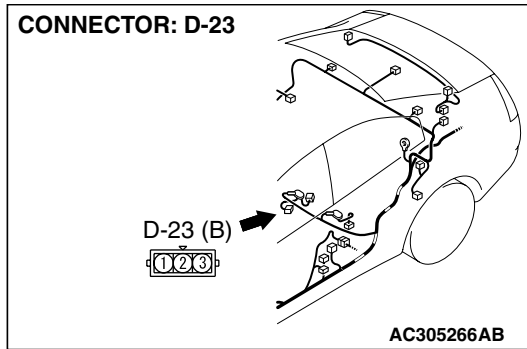

CIRCUIT OPERATION

- The PCM (terminal 21) supplies a 5-volt reference signal to the fuel tank differential pressure sensor (terminal 3). The fuel tank differential pressure sensor (terminal 2) is grounded through the PCM (terminal 22).
- The fuel tank differential pressure sensor (terminal 1) returns a voltage signal to the PCM (terminal 23) that is proportional to the pressure in the fuel tank.

TECHNICAL DESCRIPTION

- The PCM monitors the fuel tank differential pressure sensor output voltage.
- The PCM determines whether the fuel tank differential pressure sensor signal voltage is within normal operating parameters.

DESCRIPTIONS OF MONITOR METHODS

- Compare purge solenoid status with fuel tank differential pressure sensor output voltage.

MONITOR EXECUTION

- Continuous.

MONITOR EXECUTION CONDITIONS (OTHER MONITOR AND SENSOR)

Other Monitor (There is no temporary DTC stored in memory for the item monitored below)

- Evaporative emission purge solenoid monitor
- Evaporative emission ventilation solenoid monitor

Sensor (The sensors below are determined to be normal)

- Mass airflow sensor
- Barometric pressure sensor
- Intake air temperature sensor
- Engine coolant temperature sensor
- Accelerator pedal position sensor

LOGIC FLOW CHARTS (Monitor Sequence)

RATIONALITY - HIGH/LOW

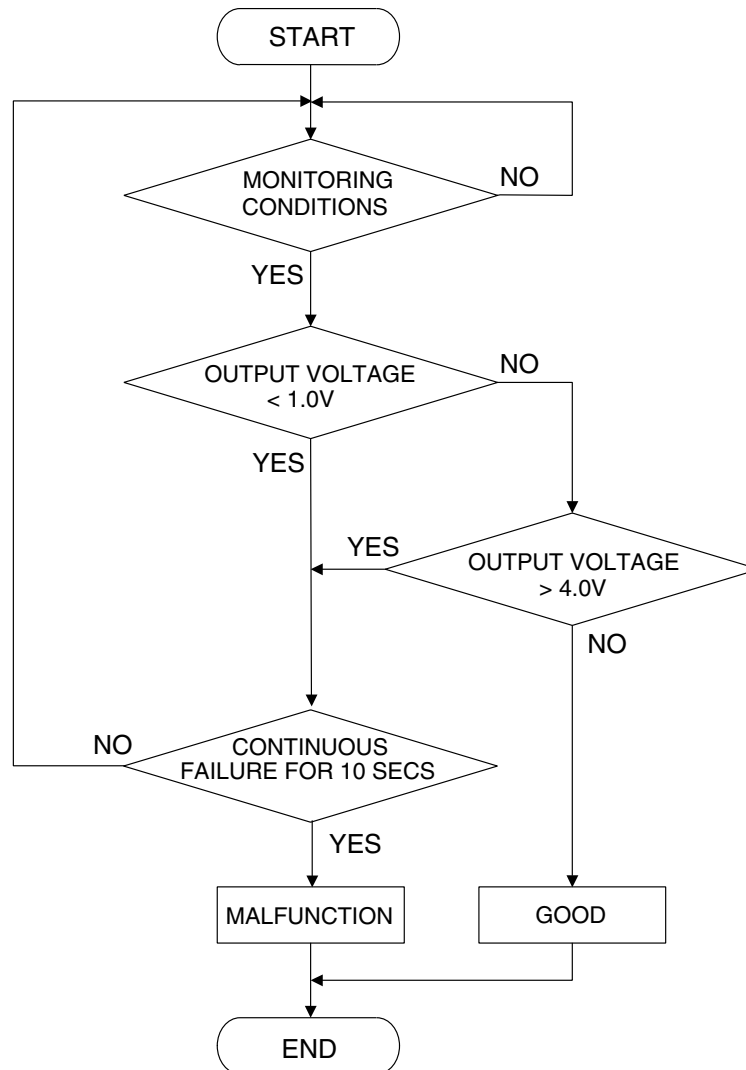

AC401446

DTC SET CONDITIONS

Check Conditions

- Intake air temperature is greater than 5°C (41°F).
- Engine speed is 1,600 r/min or greater.
- Volumetric efficiency is between 20 and 70 per cent.

Judgment Criteria

- When the evaporative emission purge solenoid is off, the fuel differential pressure sensor output voltage remains 1.0 volt or less for ten seconds.

Check Conditions

- Intake air temperature is between 5°C (41°F) and 45°C (113°F) or greater.

- Engine speed is 1,600 r/min or greater.
- Volumetric efficiency is between 20 and 70 per cent.

Judgment Criteria

- When the evaporative emission purge solenoid valve is fully operational (100 percent ratio), the fuel differential pressure sensor output voltage remains at 4.0 volts or greater for ten seconds.

OBD-II DRIVE CYCLE PATTERN

Refer to Diagnostic Function – OBD-II Drive Cycle – Procedure 1 – Evaporative Emission System Leak Monitor [P.13A-6](#).

TROUBLESHOOTING HINTS (THE MOST LIKELY CAUSES FOR THIS CODE TO BE SET ARE:)

- Malfunction of the fuel tank differential pressure sensor.
- A damaged harness in the fuel tank differential pressure sensor circuit.
- Malfunction of the PCM.

OVERVIEW OF TROUBLESHOOTING

- DTC P0450 can be set by a faulty fuel tank differential pressure sensor or related circuit, or PCM failure.
- To check for system blockage, do a performance test which uses a mechanical vacuum gauge and scan tool MB991958 set on the fuel tank differential pressure sensor (TANK PRS SNSR 73). The mechanical gauge reading is used to verify scan tool MB991958 reading. A comparison of the mechanical gauge with the reading on scan tool MB991958 will locate a problem in the system.

DIAGNOSIS**Required Special Tools:**

- MB991958: Scan Tool (MUT-III Sub Assembly)
 - MB991824: V.C.I.
 - MB991827: MUT-III USB Cable
 - MB991910: MUT-III Main Harness A
- MB991658: Test Harness Set
- MB991923: Power Plant ECU Check Harness

STEP 1. Using scan tool MB991958, check data list item 73: Fuel Tank Differential Pressure Sensor.

CAUTION

To prevent damage to scan tool MB991958, always turn the ignition switch to the "LOCK" (OFF) position before connecting or disconnecting scan tool MB991958.

(1) Connect scan tool MB991958 to the data link connector.

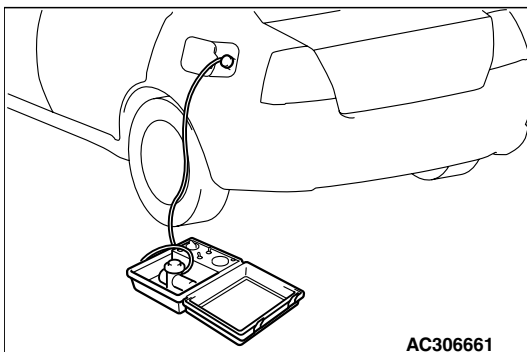
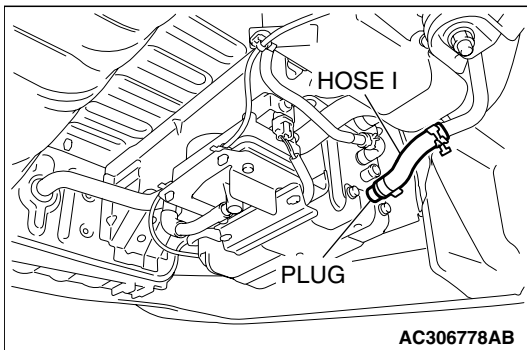
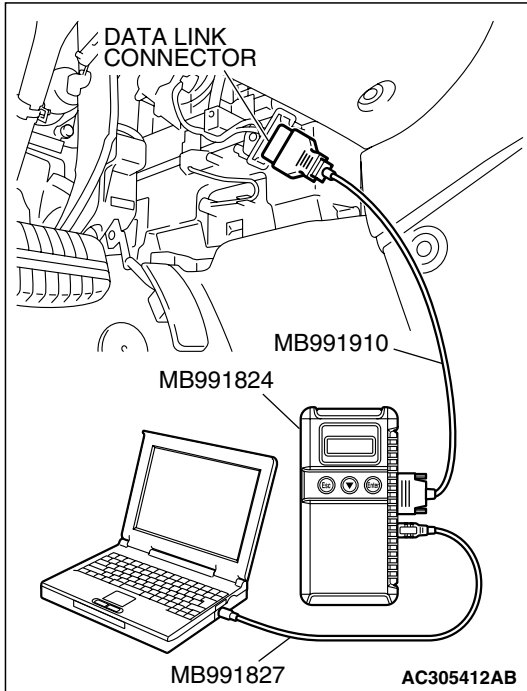

(2) Disconnect hose I from the evaporative emission canister, and plug the hose.

(3) Turn the ignition switch to the "ON" position.

(4) Remove the fuel cap.

(5) Set scan tool MB991958 to the data reading mode.

- Item 73, Fuel Tank Differential Pressure Sensor.
- The fuel tank pressure reading on the scan tool should be -1.5 to 1.5 kPa (-0.443 to 0.443 inHg).

(6) Connect the evaporative emission system pressure pump (Miller number 6872A) to the fuel tank filler tube by using fuel tank adapter (MLR-8382) and pressurize the fuel tank.

- The fuel tank pressure reading should increase.

(7) Turn the ignition switch to the "LOCK" (OFF) position. Then disconnect scan tool MB991958.

(8) Remove the evaporative emission system pressure pump (Miller number 6872A) and the fuel tank adapter (MLR-8382), and reinstall the fuel cap.

(9) Connect hose I to the evaporative emission canister.

Q: Is the fuel tank pressure between -1.5 and 1.5 kPa (-0.443 and 0.443 inHg)?

YES : It can be assumed that this malfunction is intermittent (Refer to GROUP 00, How to Use Troubleshooting/Inspection Service Points – How to Cope with Intermittent Malfunctions P.00-14). Go to Step 17.

NO : Go to Step 2.

STEP 2. Measure the sensor output voltage at PCM connector B-20 by using check harness special tool MB991923.

(1) Disconnect all the connectors from the PCM.

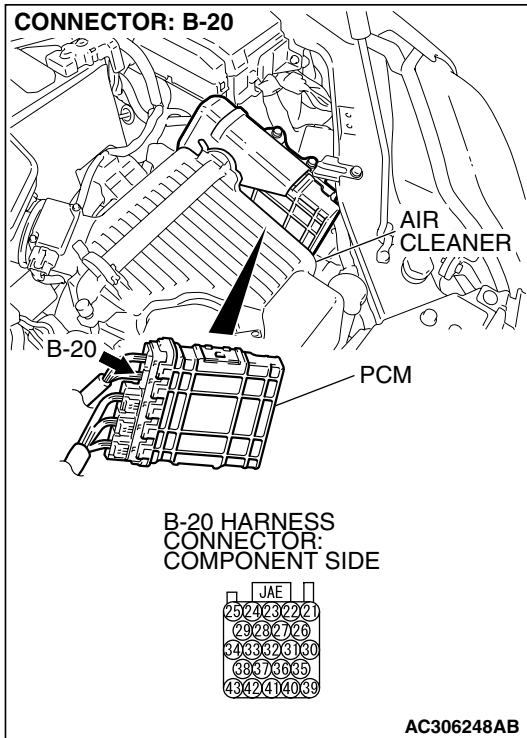

(2) Connect special tool MB991923 (check harness) between the PCM and the body-side harness connector.

(3) Turn the ignition switch to the "ON" position.

(4) Remove the fuel cap.

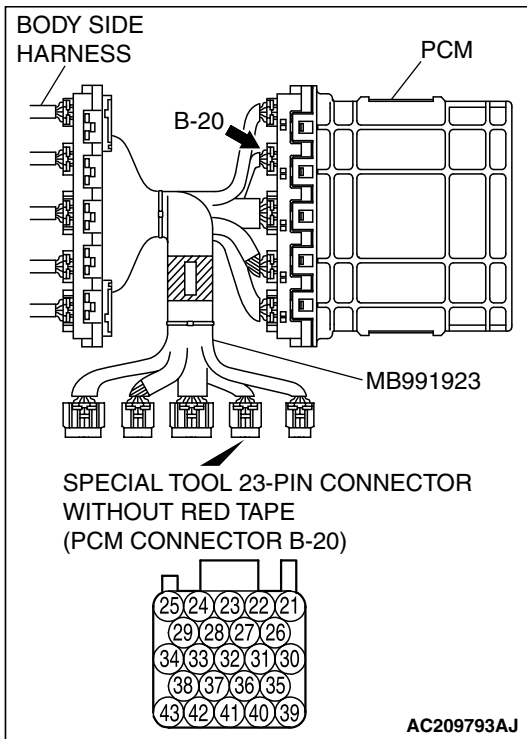

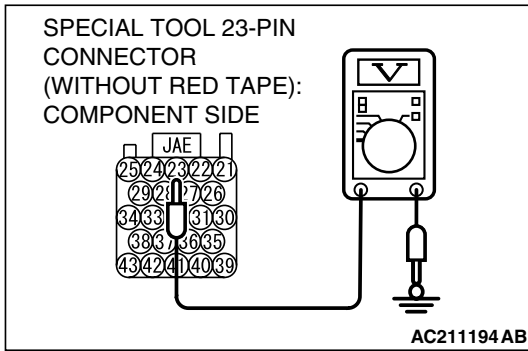

- (5) Measure the voltage between terminal 23 and ground.
 - The voltage should measure between 2.0 and 3.0 volts.
- (6) Install the fuel cap.
- (7) Turn the ignition switch to the "LOCK" (OFF) position.

Q: Is the measured voltage between 2.0 and 3.0 volts?

- YES :** Go to Step 16.
NO : Go to Step 3.

STEP 3. Measure the 5-volt reference signal at PCM connector B-20 by using check harness special tool MB991923.

- (1) Disconnect all the connectors from the PCM.

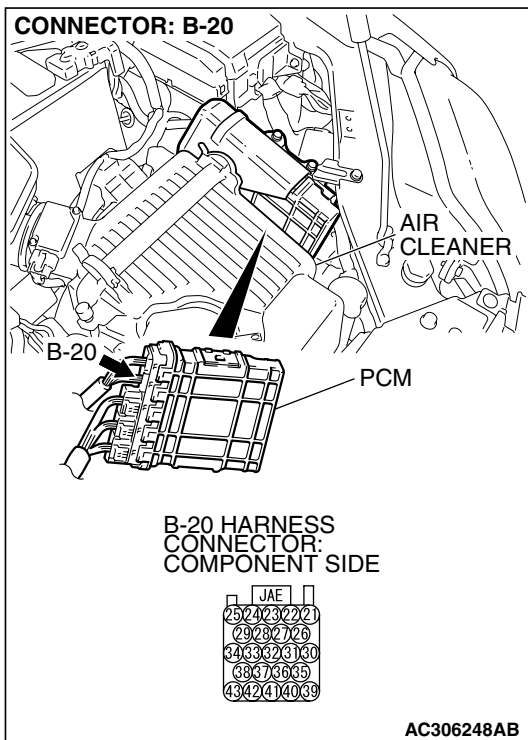

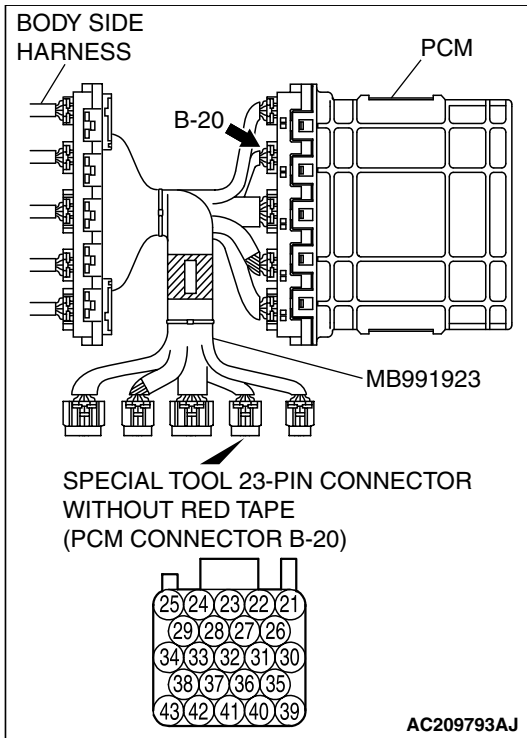

- (2) Connect special tool MB991923 (check harness) between the PCM and the body-side harness connector.
- (3) Turn the ignition switch to the "ON" position.

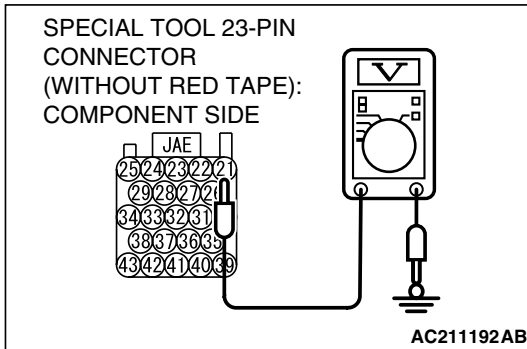

- (4) Measure the voltage between terminal 21 and ground.
 - The voltage should measure between 4.9 and 5.1 volts.
- (5) Turn the ignition switch to the "LOCK" (OFF) position.

Q: Is the measured voltage between 4.9 and 5.1 volts?

- YES** : Go to Step 5.
- NO** : Go to Step 4.

STEP 4. Check PCM connector B-20 for loose, corroded or damaged terminals, or terminals pushed back in the connector.

Q: Are the connector and terminals in good condition?

YES : Go to Step 16.

NO : Repair or replace the faulty components (Refer to GROUP 00E, Harness Connector Inspection [P.00E-2](#)). Then go to Step 17.

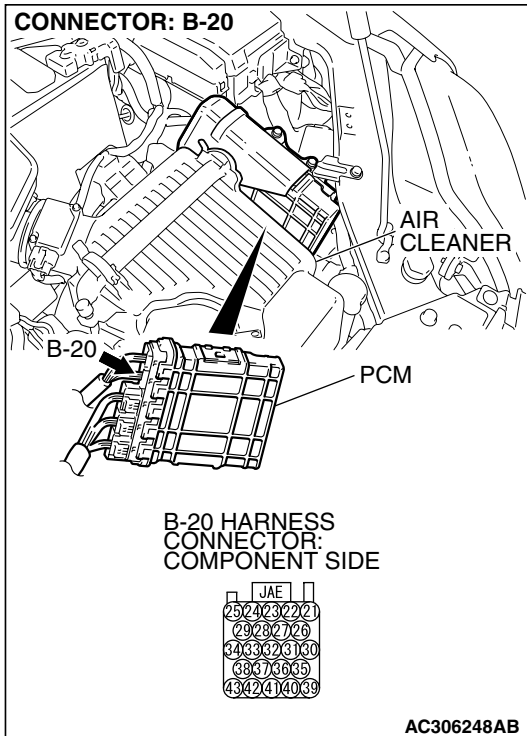

STEP 5. Measure the sensor output voltage at PCM connector B-20 by using check harness special tool MB991923.

(1) Disconnect all the connectors from the PCM.

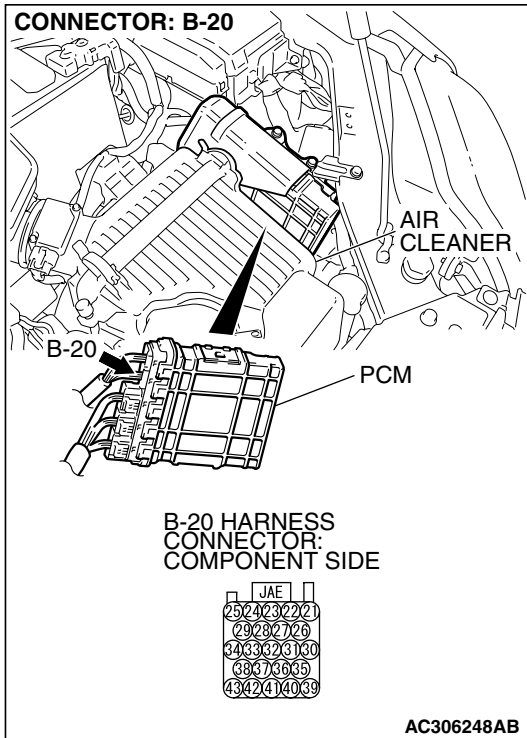

(2) Connect special tool MB991923 (check harness) between the PCM and the body-side harness connector.

(3) Turn the ignition switch to the "ON" position.

(4) Remove the fuel cap.

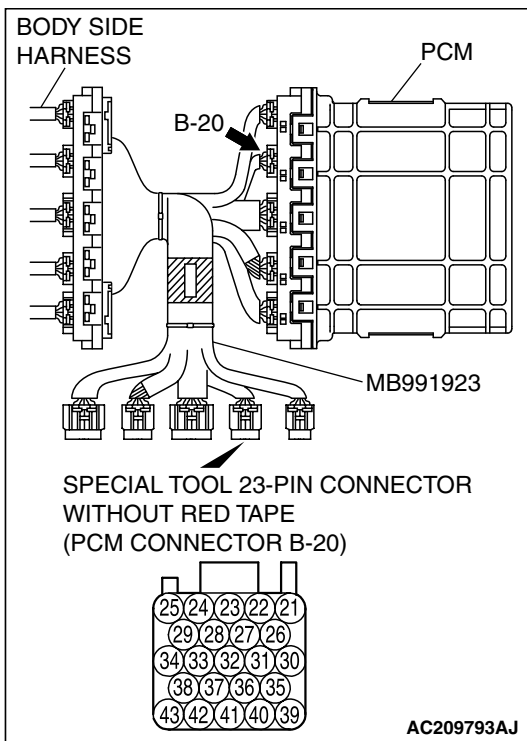

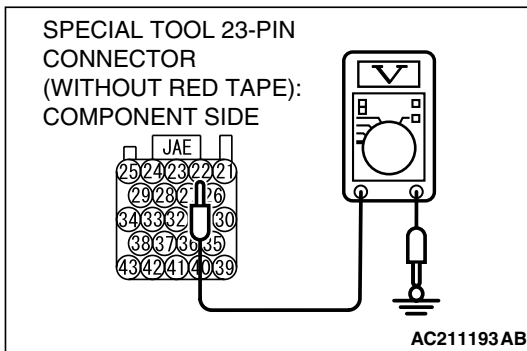

- (5) Measure the voltage between terminal 22 and ground.
 - The voltage should measure 0.5 volt or less.
- (6) Install the fuel cap.
- (7) Turn the ignition switch to the "LOCK" (OFF) position.

Q: Is the measured voltage 0.5 volt or less?

- YES :** Go to Step 6.
NO : Go to Step 9.

STEP 6. Measure the signal voltage at intermediate connector D-23.

- (1) Remove the rear seat cushion assembly (Refer to GROUP 52A, Rear Seat P.52A-29).
- (2) Remove the hole cover (RH).

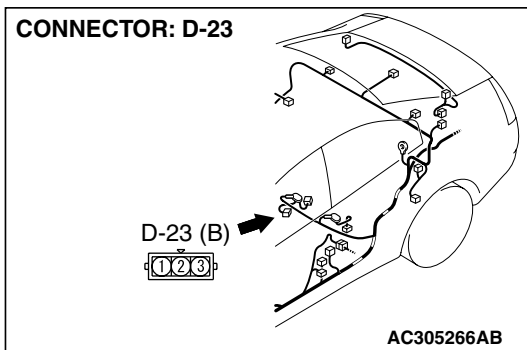
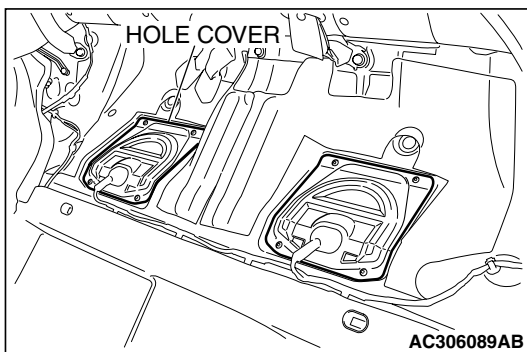

- (3) Disconnect fuel tank differential pressure sensor connector D-23.

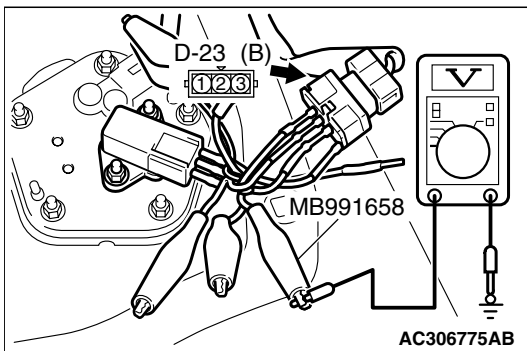

- (4) Use special tool MB991658 to connect terminals 1, 2 and 3 of the fuel tank differential pressure sensor connector D-23.
- (5) Turn the ignition switch to the "ON" position.
- (6) Remove the fuel cap.
- (7) Measure the voltage between connector D-23 terminal 1 and ground.
 - The voltage should measure between 2.0 and 3.0 volts.
- (8) Turn the ignition switch to the "LOCK" (OFF) position.

Q: Is the measured voltage between 2.0 and 3.0 volts?

- YES :** Go to Step 7.
NO : Go to Step 15.

STEP 7. Check PCM connector B-20, intermediate connector C-25 and fuel tank differential pressure sensor connector D-23 for loose, corroded or damaged terminals, or terminals pushed back in the connector.

Q: Are the connectors and terminals in good condition?

YES : Go to Step 8.

NO : Repair or replace the faulty components (Refer to GROUP 00E, Harness Connector Inspection [P.00E-2](#)). Then go to Step 17.

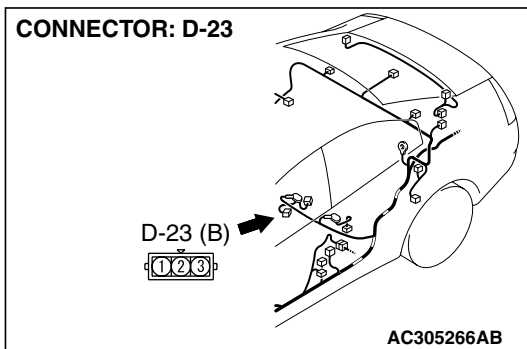
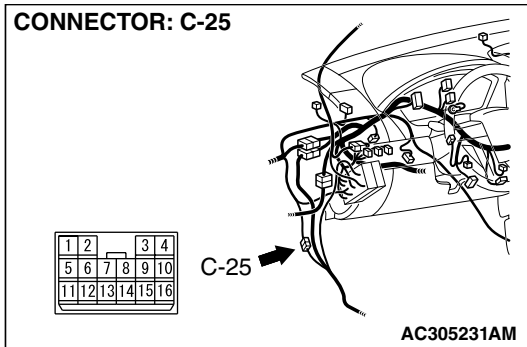
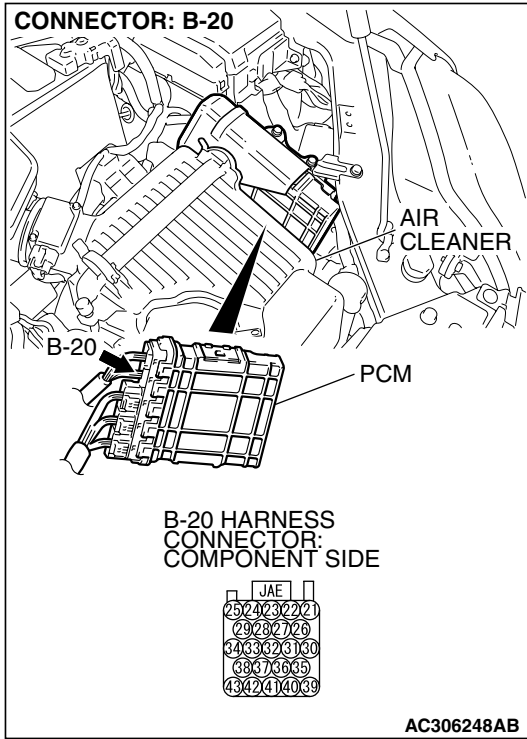

STEP 8. Check the harness wire between PCM connector B-20 terminal 23 and fuel tank differential pressure sensor connector D-23 terminal 1 for damage.

Q: Is the harness wire in good condition?

YES : This malfunction is intermittent (Refer to GROUP 00, How to Use Troubleshooting/Inspection Service Points – How to Cope with Intermittent Malfunctions [P.00-14](#)). Go to Step 17.

NO : Repair the damaged harness wire. Then go to Step 17.

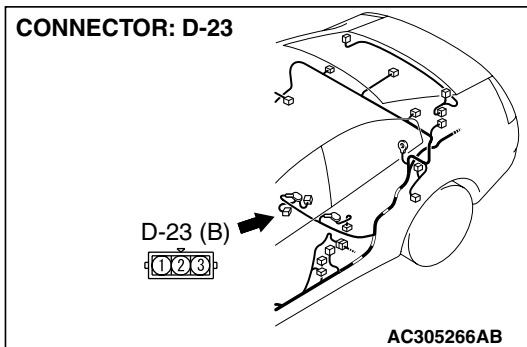
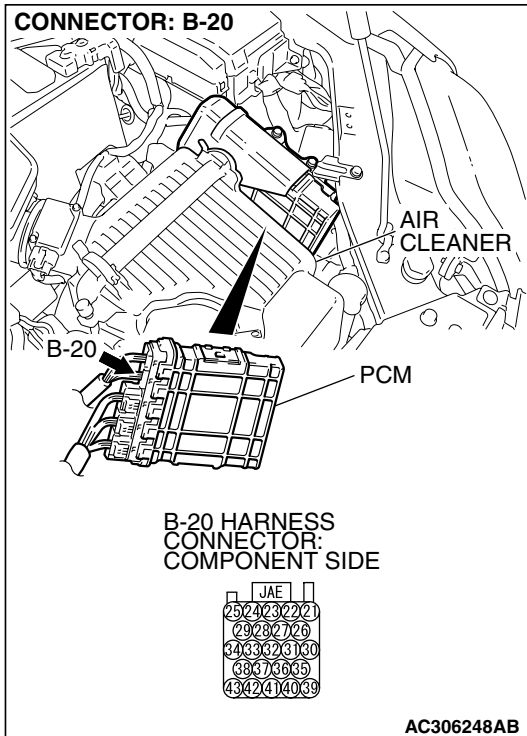

STEP 9. Measure the 5-volt reference signal at fuel tank differential pressure sensor connector D-23.

- (1) Remove the rear seat cushion assembly (Refer to GROUP 52A, Rear Seat P.52A-29).
- (2) Remove the hole cover (RH).

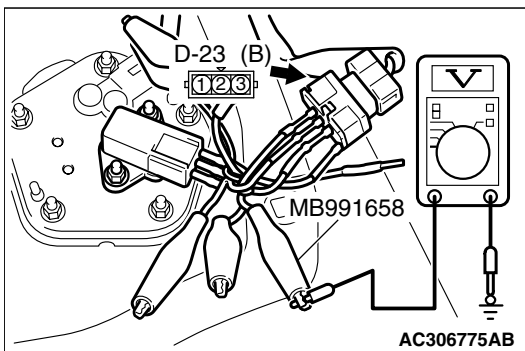
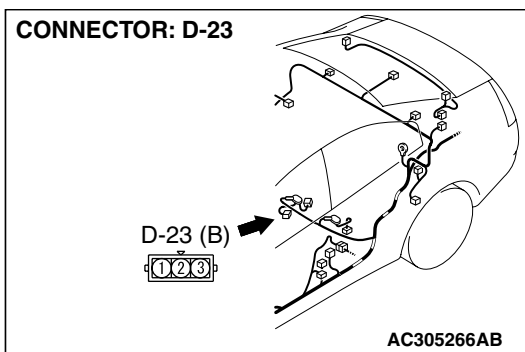
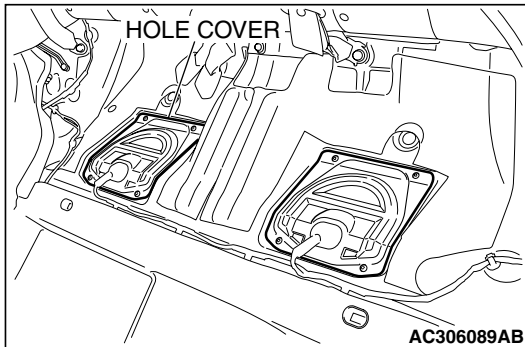

- (3) Disconnect fuel tank differential pressure sensor connector D-23.

- (4) Use special tool MB991658 to connect terminals 1,2 and 3 of the fuel tank differential pressure sensor connector D-23.
- (5) Turn the ignition switch to the "ON" position.
- (6) Measure the voltage between terminal 3 and ground.
 - The voltage should measure between 4.9 and 5.1 volts.
- (7) Turn the ignition switch to the "LOCK" (OFF) position.

Q: Is the measured voltage between 4.9 and 5.1 volts?

- YES :** Go to Step 12.
NO : Go to Step 10.

STEP 10. Check PCM connector B-20, intermediate connector C-25 and fuel tank differential pressure sensor connector D-23 for loose, corroded or damaged terminals, or terminals pushed back in the connector.

Q: Are the connectors and terminals in good condition?

YES : Go to Step 11.

NO : Repair or replace the faulty components (Refer to GROUP 00E, Harness Connector Inspection [P.00E-2](#)). Then go to Step 17.

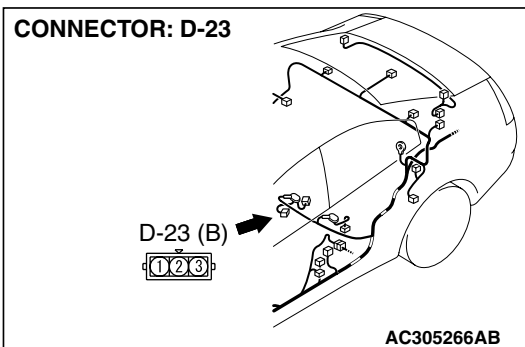
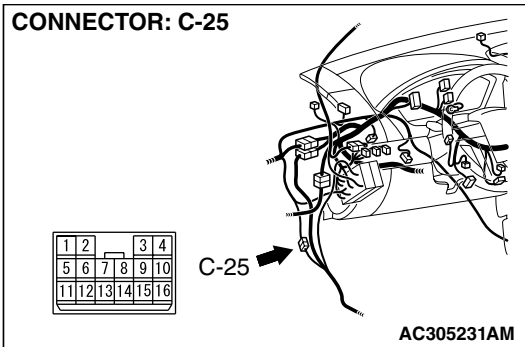
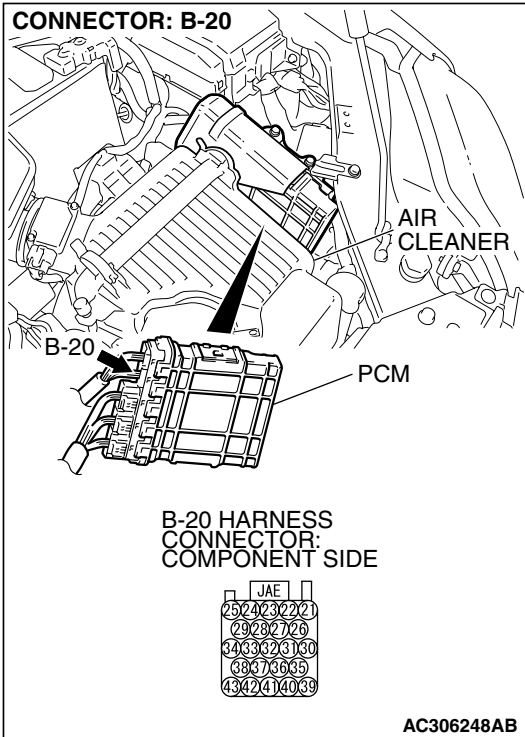

STEP 11. Check the harness wire between PCM connector B-20 terminal 21 and fuel tank differential pressure sensor connector D-23 terminal 3 for damage.

Q: Are the harness wires in good condition?

YES : It can be assumed that this malfunction is intermittent (Refer to GROUP 00, How to Use Troubleshooting/Inspection Service Points – How to Cope with Intermittent Malfunctions P.00-14). Go to Step 17.

NO : Repair the damaged harness wires. Then go to Step 17.

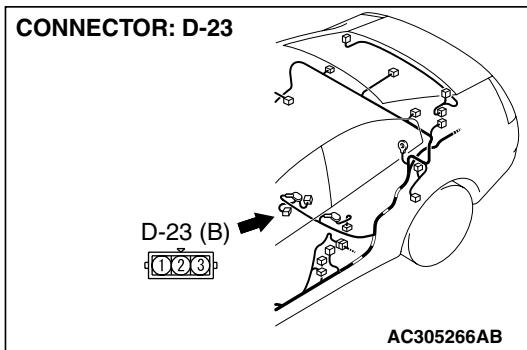
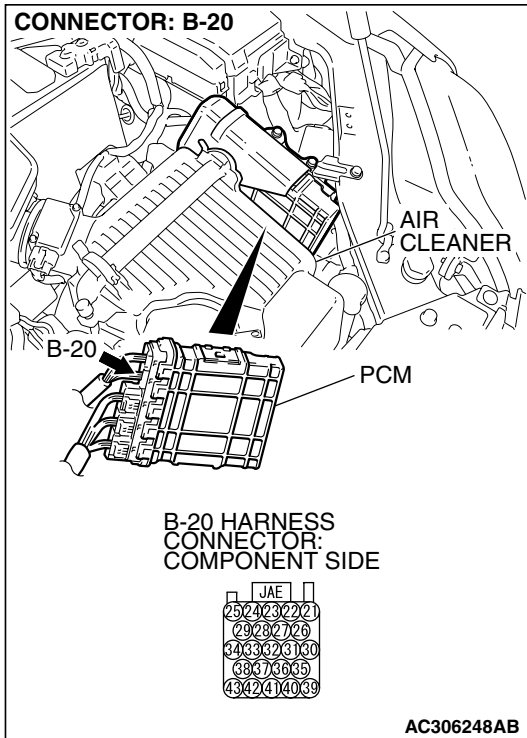

STEP 12. Measure the fuel tank differential pressure sensor return voltage at fuel tank differential pressure sensor connector D-23.

- (1) Remove the rear seat cushion assembly (Refer to GROUP 52A, Rear Seat P.52A-29).
- (2) Remove the hole cover (RH).

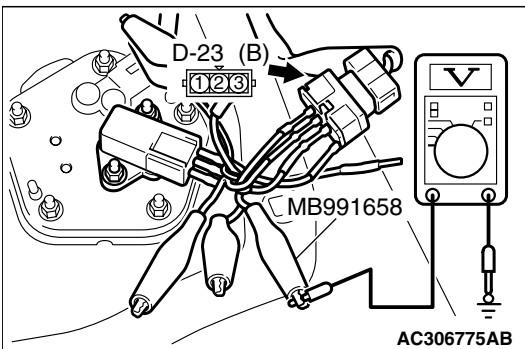
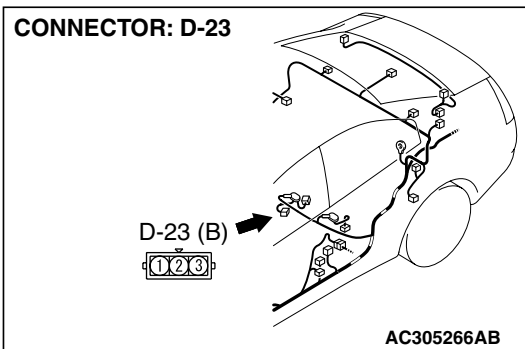
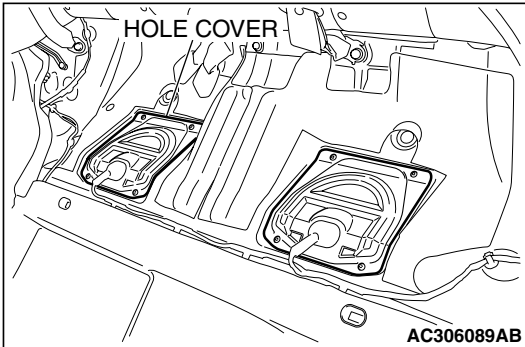

- (3) Disconnect fuel tank differential pressure sensor connector D-23.

- (4) Use special tool MB991658 to connect terminals 1,2 and 3 of the fuel tank differential pressure sensor connector D-23.
- (5) Turn the ignition switch to the "ON" position.
- (6) Measure the voltage between terminal 2 and ground.
 - The voltage should measure 0.5 volt or less.
- (7) Turn the ignition switch to the "LOCK" (OFF) position.

Q: Is the measured voltage 0.5 volt or less?

- YES :** Go to Step 13.
NO : Go to Step 17.

STEP 13. Check PCM connector B-20, intermediate connector C-25 and fuel tank differential pressure sensor connector D-23 for loose, corroded or damaged terminals, or terminals pushed back in the connector.

Q: Are the connectors and terminals in good condition?

YES : Go to Step 14.

NO : Repair or replace the faulty components (Refer to GROUP 00E, Harness Connector Inspection [P.00E-2](#)). Then go to Step 17.

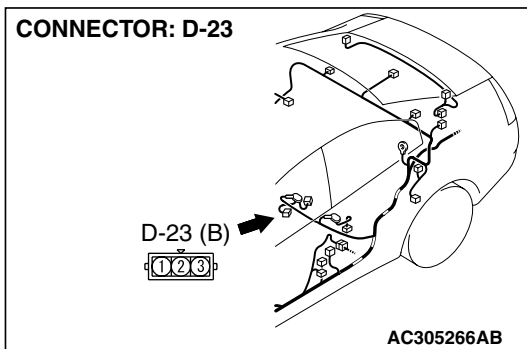
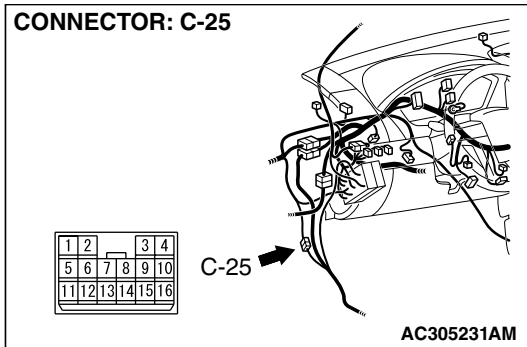
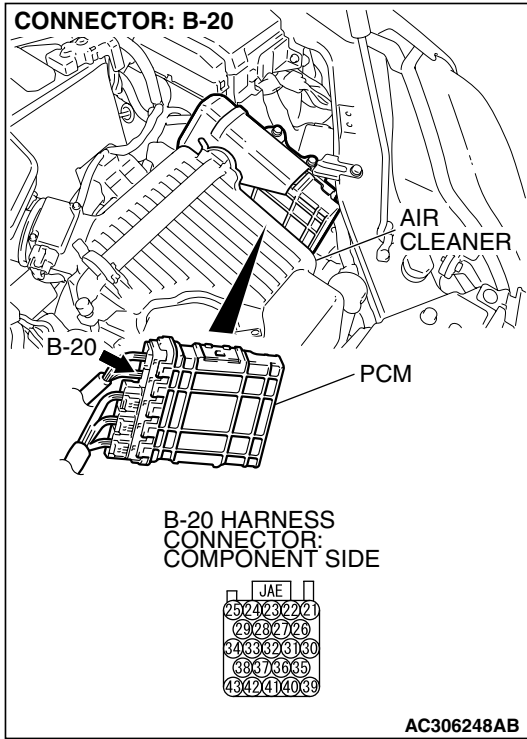

STEP 14. Check the harness wires between PCM connector B-20 terminal 22 and fuel tank differential pressure sensor connector D-23 terminal 2 for damage.
Q: Are the harness wires in good condition?

YES : Go to Step 17.

NO : Repair the damaged harness wires. Then go to Step 17.

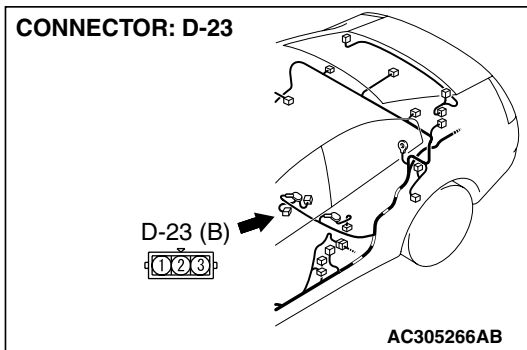
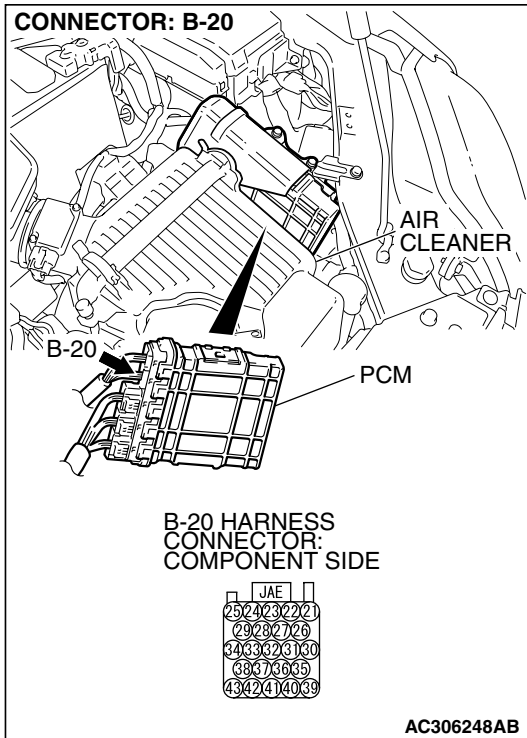

STEP 15. Check fuel tank differential pressure sensor connector D-23 for loose, corroded or damaged terminals, or terminals pushed back in the connector.

Q: Is the connectors and terminals in good condition?

YES : Replace the fuel tank differential pressure sensor. Then go to Step 17.

NO : Repair or replace the faulty components (Refer to GROUP 00E, Harness Connector Inspection [P.00E-2](#)). Then go to Step 17.

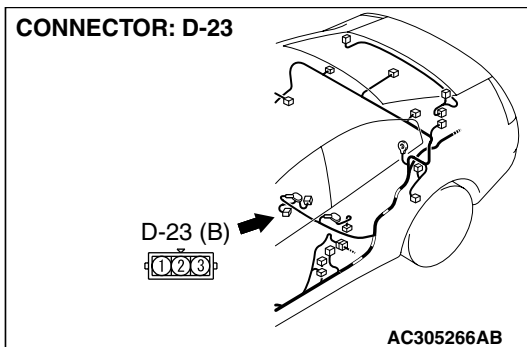

STEP 16. Using scan tool MB991958, check data list item 73: Fuel Tank Differential Pressure Sensor.

⚠ CAUTION

To prevent damage to scan tool MB991958, always turn the ignition switch to the "LOCK" (OFF) position before connecting or disconnecting scan tool MB991958.

(1) Connect scan tool MB991958 to the data link connector.

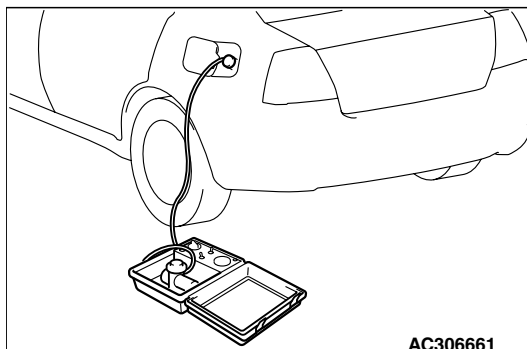
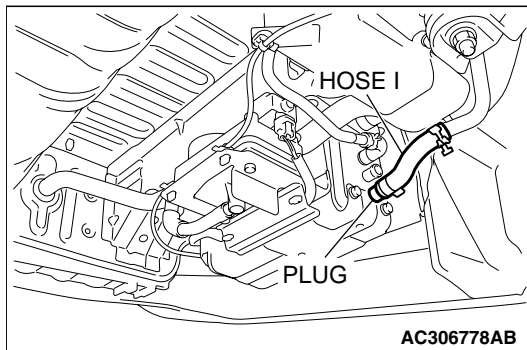
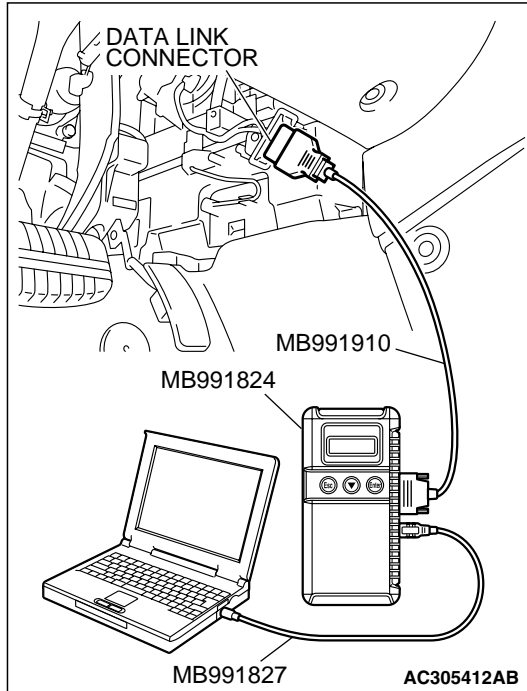

(2) Disconnect hose I from the evaporative emission canister, and plug the hose.

(3) Turn the ignition switch to the "ON" position.

(4) Remove the fuel cap.

(5) Set scan tool MB991958 to the data reading mode.

- Item 73, Fuel Tank Differential Pressure Sensor.
- The fuel tank pressure reading on the scan tool should be -1.5 to 1.5 kPa (-0.443 to 0.443 inHg).

(6) Connect the evaporative emission system pressure pump (Miller number 6872A) to the fuel tank filler tube by using fuel tank adapter (MLR-8382) and pressurize the fuel tank.

- The fuel tank pressure reading should increase.

(7) Turn the ignition switch to the "LOCK" (OFF) position. Then disconnect scan tool MB991958.

(8) Remove the evaporative emission system pressure pump (Miller number 6872A) and the fuel tank adapter (MLR-8382), and reinstall the fuel cap.

(9) Connect hose I to the evaporative emission canister.

Q: Is the fuel tank pressure between -1.5 and 1.5 kPa (-0.443 and 0.443 inHg)?

YES : It can be assumed that this malfunction is intermittent (Refer to GROUP 00, How to Use Troubleshooting/Inspection Service Points – How to Cope with Intermittent Malfunctions P.00-14). Go to Step 17.

NO : Replace the PCM (Refer to P.13A-1140). Then go to Step 17 .

STEP 17. Perform the OBD-II drive cycle.

- (1) Carry out a test drive with the drive cycle pattern (Refer to Diagnostic Function – OBD-II Drive Cycle – Procedure 1 – Evaporative Emission System Leak Monitor P.13A-6).
- (2) Read the diagnostic trouble code (DTC).

Q: Is DTC P0450 set?

YES : Repeat the troubleshooting from Step 2.

NO : The procedure is complete.

DTC P0451: Evaporative Emission System Pressure Sensor Range/Performance

SYSTEM DIAGRAM

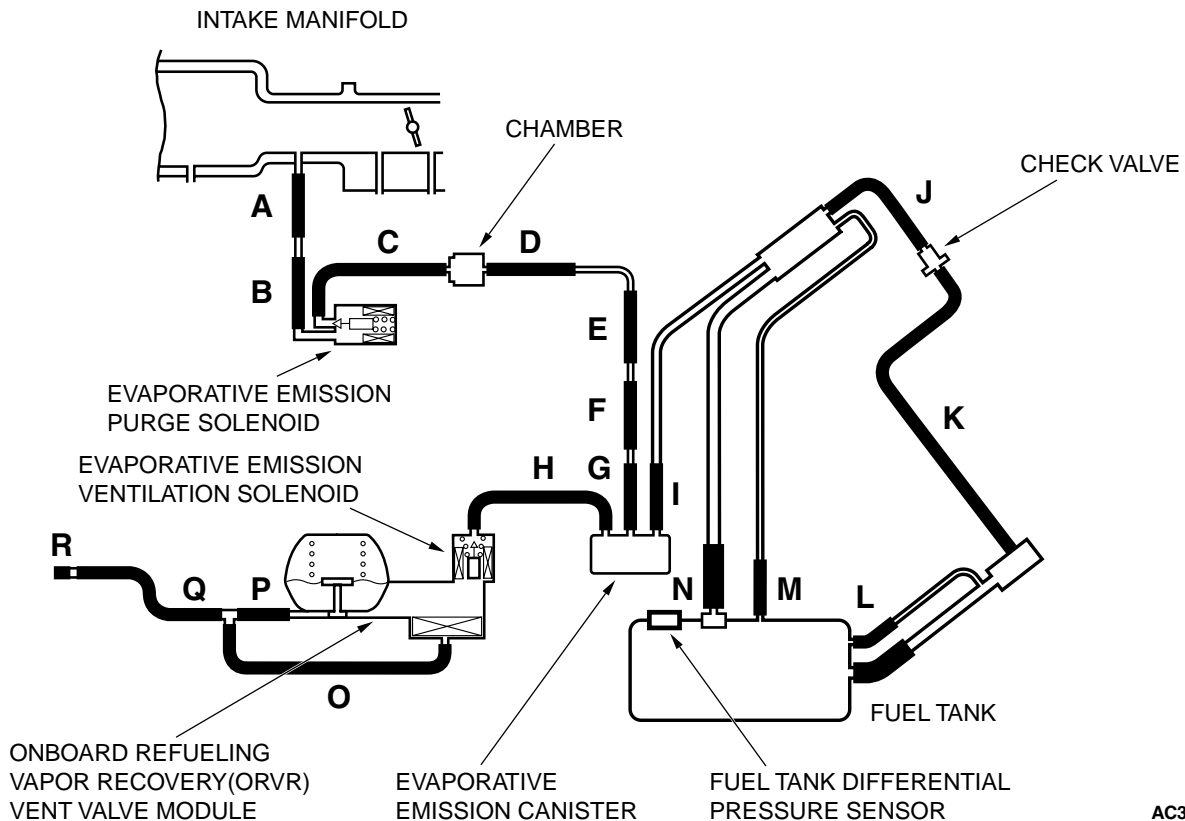

AC306277 AC

Fuel Tank Differential Pressure Sensor Circuit

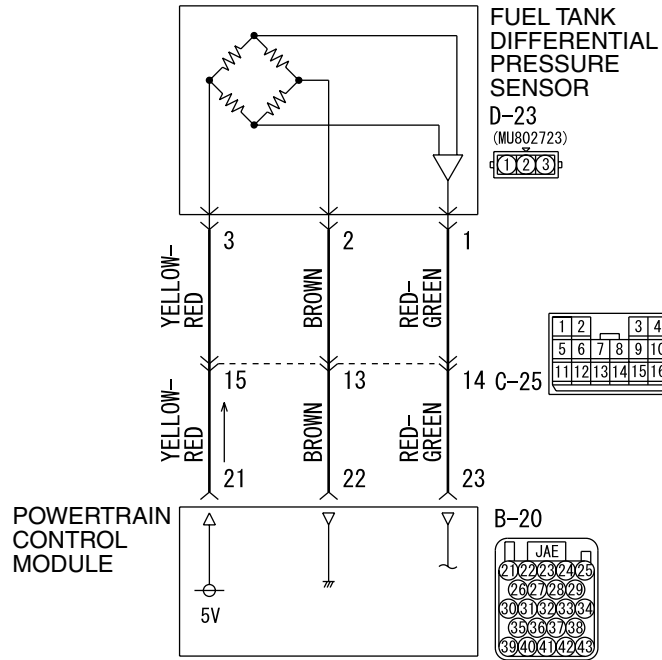

W4P13M02AA
AC306128

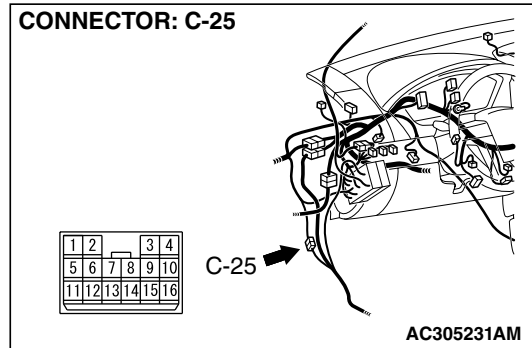
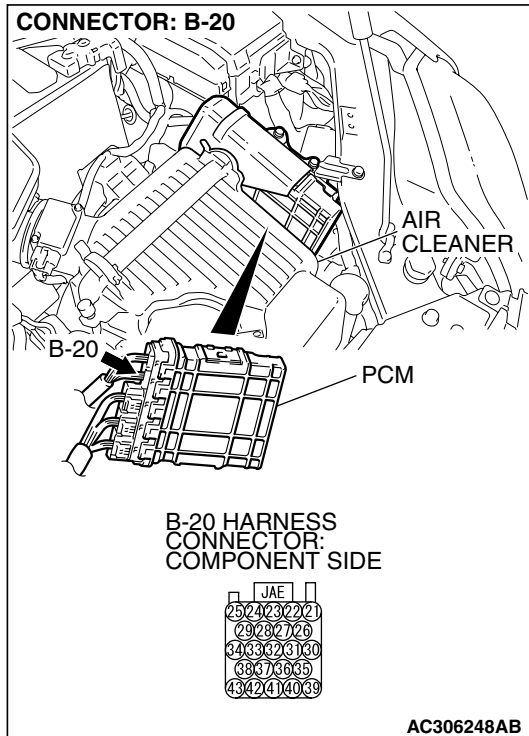

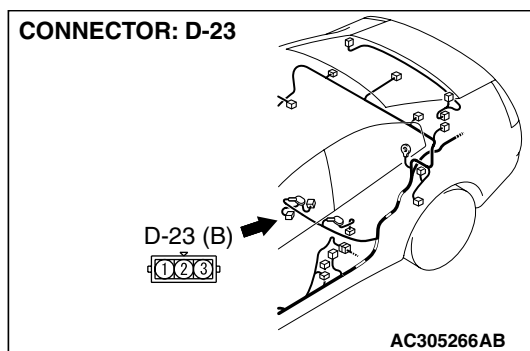

CIRCUIT OPERATION

- The PCM (terminal 21) supplies a 5-volt reference signal to the fuel tank differential pressure sensor (terminal 3). The fuel tank differential pressure sensor (terminal 2) is grounded through the PCM (terminal 22).
- The fuel tank differential pressure sensor (terminal 1) returns a voltage signal to the PCM (terminal 23) that is proportional to the pressure in the fuel tank.

TECHNICAL DESCRIPTION

- The PCM monitors the fuel tank differential pressure sensor signal voltage.
- The PCM determines whether the fuel tank differential pressure sensor signal voltage is within normal operating parameters.

DESCRIPTIONS OF MONITOR METHODS

- Detect malfunction if change of fuel tank differential pressure sensor output voltage during idling stays large during specified go/stop operations.

MONITOR EXECUTION

- Continuous.

MONITOR EXECUTION CONDITIONS (OTHER MONITOR AND SENSOR)

Other Monitor (There is no temporary DTC stored in memory for the item monitored below)

- Evaporative emission purge solenoid monitor
- Evaporative emission ventilation solenoid monitor

Sensor (The sensors below are determined to be normal)

- Mass airflow sensor
- Barometric pressure sensor
- Intake air temperature sensor
- Engine coolant temperature sensor
- Accelerator pedal position sensor

LOGIC FLOW CHARTS (Monitor Sequence)

RATIONALITY - NOISE

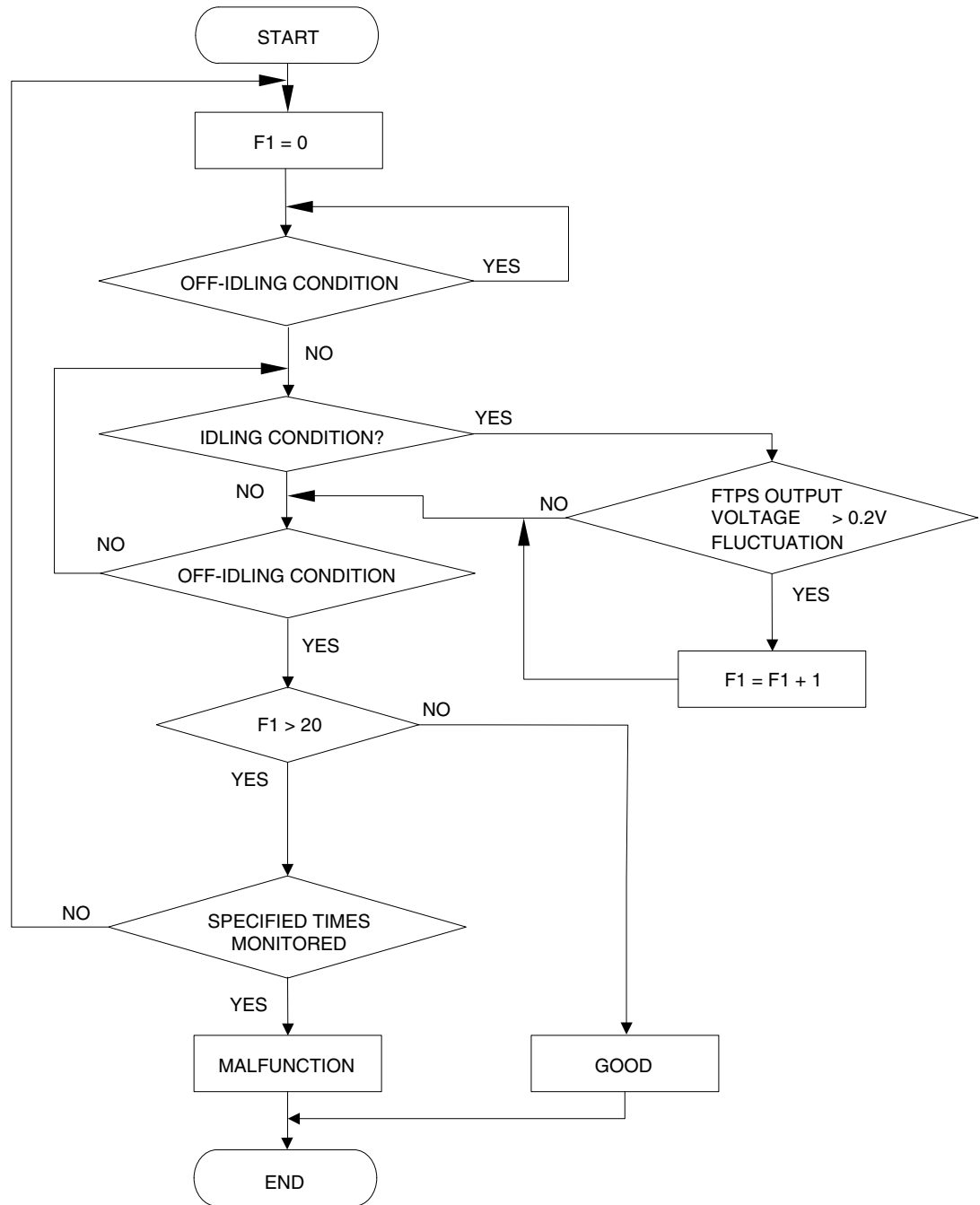

AC306647

DTC SET CONDITIONS

Check Conditions

- Throttle valve is closed.
- Vehicle speed is 1.5 km/h (0.93 mph) or less.

Judgment Criteria

- If the voltage signal from the fuel tank differential pressure sensor changes by 0.2 volt or more, DTC P0451 will set. The code may also set if a sudden pressure fluctuation occurs twenty times while the engine is idling, and then four consecutive times during normal driving.

NOTE: If the number of sudden pressure fluctuations does not reach twenty during any one period of engine idling, or if the ignition switch is turned OFF, the counter will reset to zero.

NOTE: The conditions for deviating from idling operation are as follows:

- Vehicle speed is 50 km/h (31 mph) or greater.

OBD-II DRIVE CYCLE PATTERN

Refer to Diagnostic Function – OBD-II Drive Cycle – Procedure 1 – Evaporative Emission System Leak Monitor [P.13A-6](#).

TROUBLESHOOTING HINTS (THE MOST LIKELY CAUSES FOR THIS CODE TO BE SET ARE:)

- Malfunction of the fuel tank differential pressure sensor.
- A damaged harness in the fuel tank differential pressure sensor circuit.
- Malfunction of the PCM.

OVERVIEW OF TROUBLESHOOTING

- DTC P0451 can be set by a faulty fuel tank differential pressure sensor or related circuit, or PCM failure.
- To check for system blockage, do a performance test which uses a mechanical vacuum gauge and scan tool MB991958 set on the fuel tank differential pressure sensor (TANK PRS SNSR 73). The mechanical gauge reading is used to verify scan tool MB991958 reading. A comparison of the mechanical gauge with the reading on scan tool MB991958 will locate a problem in the system.

DIAGNOSIS

Required Special Tools:

- MB991958: Scan Tool (MUT-III Sub Assembly)
 - MB991824: V.C.I.
 - MB991827: MUT-III USB Cable
 - MB991910: MUT-III Main Harness A
- MB991658: Test Harness Set
- MB991923: Power Plant ECU Check Harness

STEP 1. Using scan tool MB991958, check data list item 73: Fuel Tank Differential Pressure Sensor.

⚠ CAUTION

To prevent damage to scan tool MB991958, always turn the ignition switch to the "LOCK" (OFF) position before connecting or disconnecting scan tool MB991958.

(1) Connect scan tool MB991958 to the data link connector.

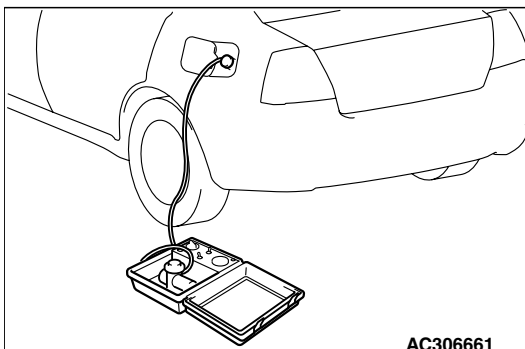
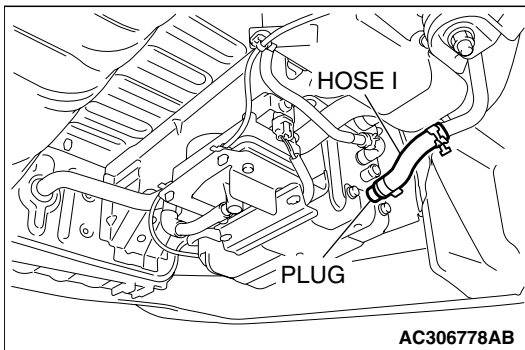
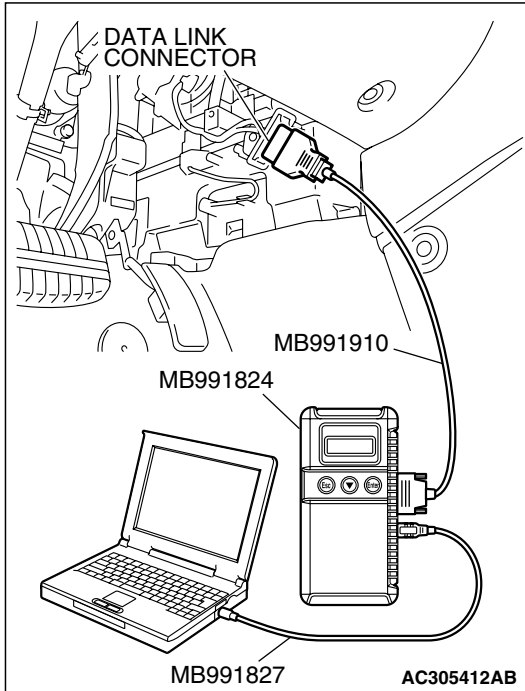

(2) Disconnect hose I from the evaporative emission canister, and plug the hose.

(3) Turn the ignition switch to the "ON" position.

(4) Remove the fuel cap.

(5) Set scan tool MB991958 to the data reading mode.

- Item 73, Fuel Tank Differential Pressure Sensor.
- The fuel tank pressure reading on the scan tool should be -1.5 to 1.5 kPa (-0.443 to 0.443 inHg).

(6) Connect the evaporative emission system pressure pump (Miller number 6872A) to the fuel tank filler tube by using fuel tank adapter (MLR-8382) and pressurize the fuel tank.

- The fuel tank pressure reading should increase.

(7) Turn the ignition switch to the "LOCK" (OFF) position. Then disconnect scan tool MB991958.

(8) Remove the evaporative emission system pressure pump (Miller number 6872A) and the fuel tank adapter (MLR-8382), and reinstall the fuel cap.

(9) Connect hose I to the evaporative emission canister.

Q: Is the fuel tank pressure between -1.5 and 1.5 kPa (-0.443 and 0.443 inHg)?

YES : It can be assumed that this malfunction is intermittent (Refer to GROUP 00, How to Use Troubleshooting/Inspection Service Points – How to Cope with Intermittent Malfunctions P.00-14). Go to Step 17.

NO : Go to Step 2.

STEP 2. Measure the sensor output voltage at PCM connector B-20 by using check harness special tool MB991923.

(1) Disconnect all the connectors from the PCM.

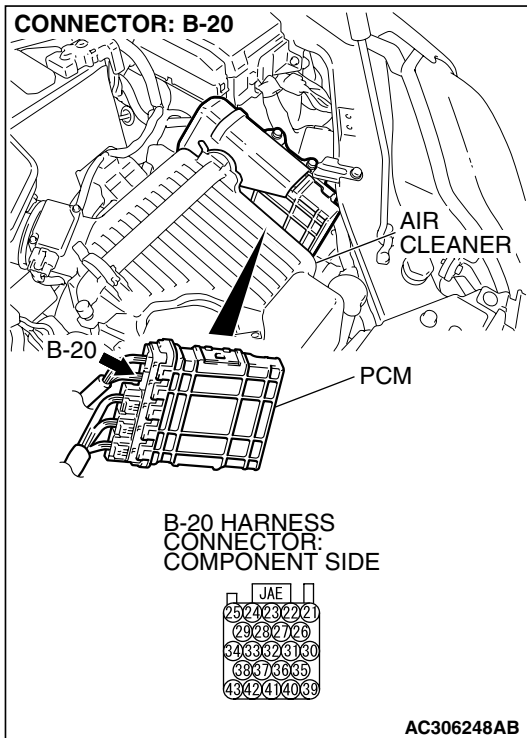

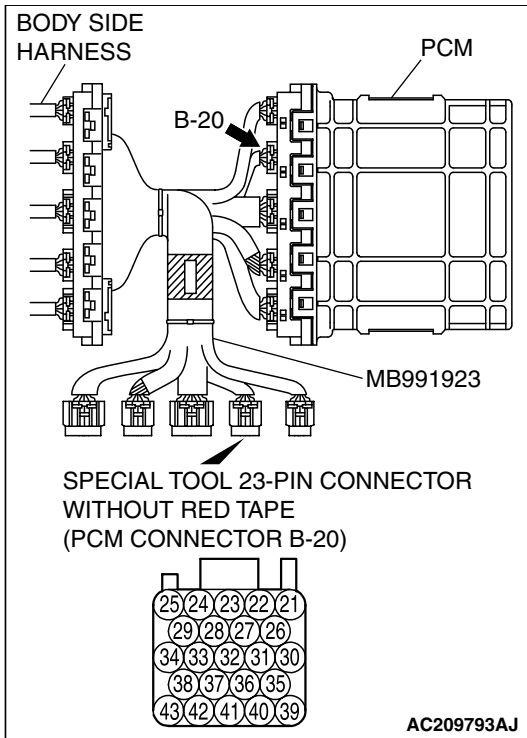

- (2) Connect special tool MB991923 (check harness) between the PCM and the body-side harness connector.
- (3) Turn the ignition switch to the "ON" position.
- (4) Remove the fuel cap.

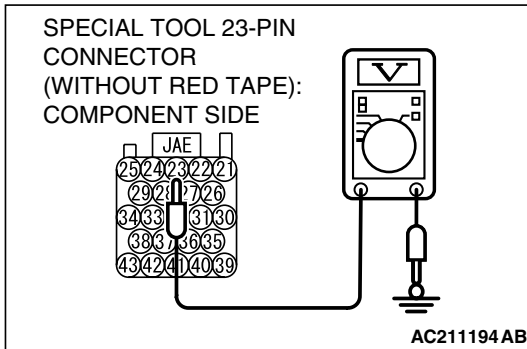

- (5) Measure the voltage between terminal 23 and ground.
 - The voltage should measure between 2.0 and 3.0 volts.
- (6) Install the fuel cap.
- (7) Turn the ignition switch to the "LOCK" (OFF) position.

Q: Is the measured voltage between 2.0 and 3.0 volts?

- YES :** Go to Step 16.
NO : Go to Step 3.

STEP 3. Measure the 5-volt reference signal at PCM connector B-20 by using check harness special tool MB991923.

(1) Disconnect all the connectors from the PCM.

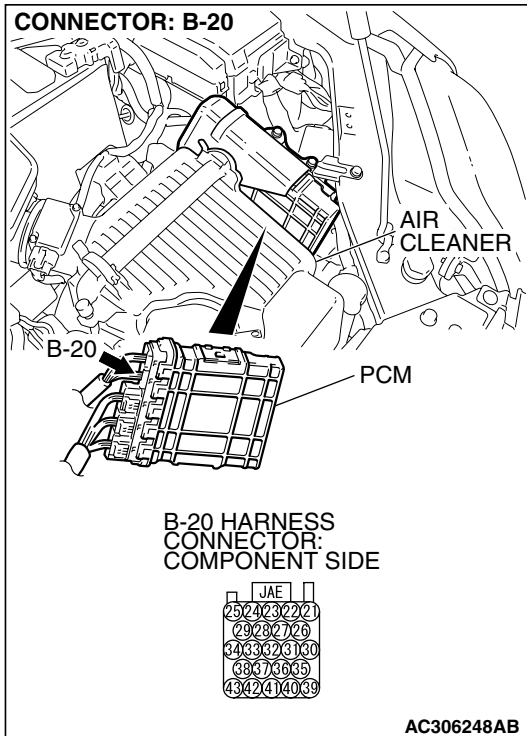

- (2) Connect special tool MB991923 (check harness) between the PCM and the body-side harness connector.
- (3) Turn the ignition switch to the "ON" position.

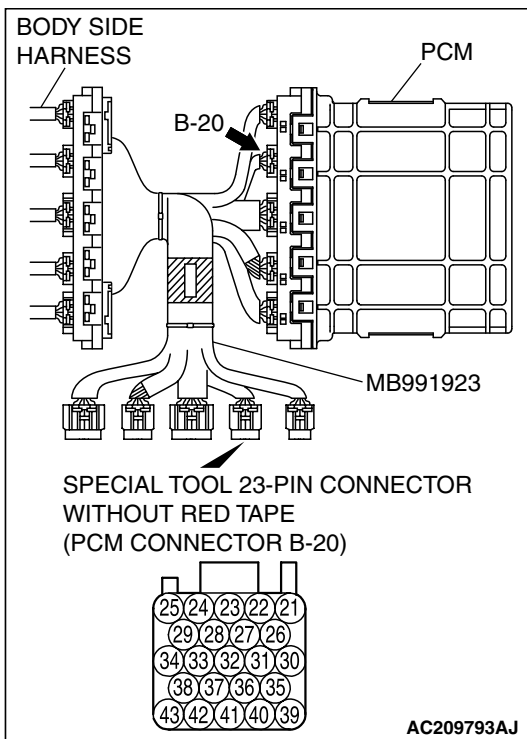

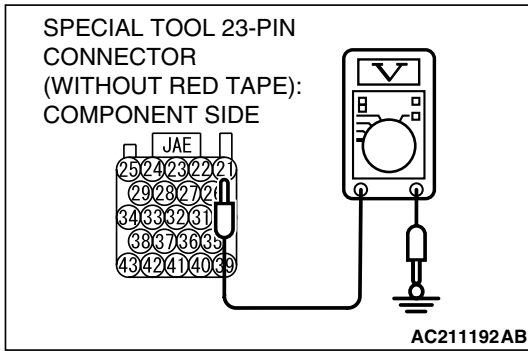

- (4) Measure the voltage between terminal 21 and ground.
 - The voltage should measure between 4.9 and 5.1 volts.
- (5) Turn the ignition switch to the "LOCK" (OFF) position.

Q: Is the measured voltage between 4.9 and 5.1 volts?
YES : Go to Step 5.
NO : Go to Step 4.

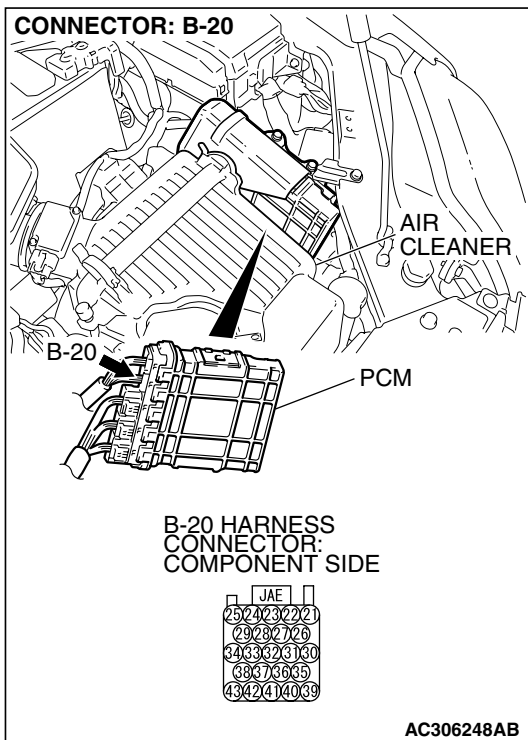

STEP 4. Check PCM connector B-20 for loose, corroded or damaged terminals, or terminals pushed back in the connector.

Q: Are the connector and terminals in good condition?
YES : Go to Step 16.
NO : Repair or replace the faulty components (Refer to GROUP 00E, Harness Connector Inspection [P.00E-2](#)). Then go to Step 17.

STEP 5. Measure the sensor output voltage at PCM connector B-20 by using check harness special tool MB991923.

(1) Disconnect all the connectors from the PCM.

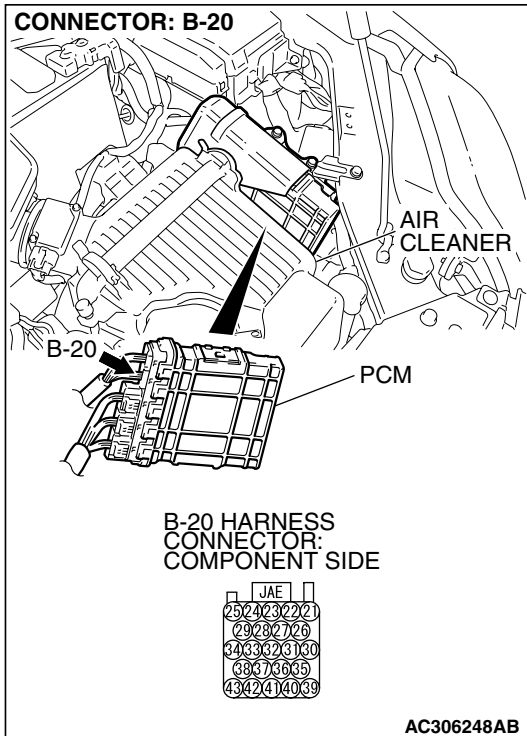

- (2) Connect special tool MB991923 (check harness) between the PCM and the body-side harness connector.
- (3) Turn the ignition switch to the "ON" position.
- (4) Remove the fuel cap.

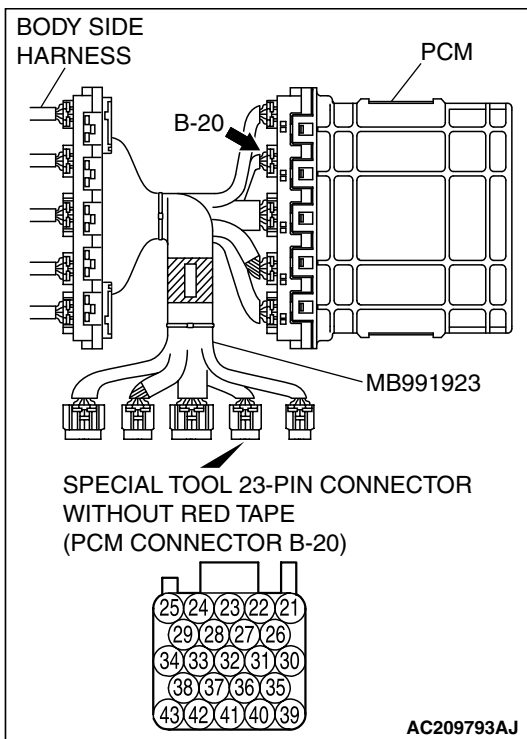

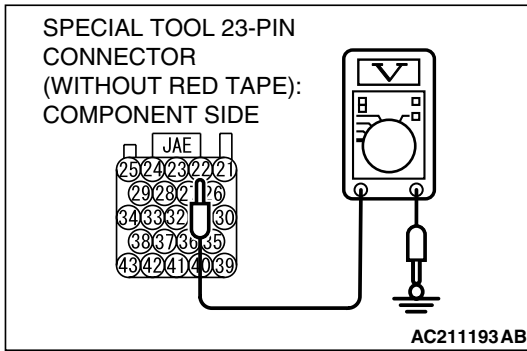

- (5) Measure the voltage between terminal 22 and ground.
 - The voltage should measure 0.5 volt or less.
- (6) Install the fuel cap.
- (7) Turn the ignition switch to the "LOCK" (OFF) position.

Q: Is the measured voltage 0.5 volt or less?

- YES** : Go to Step 6.
- NO** : Go to Step 9.

STEP 6. Measure the signal voltage at intermediate connector D-23.

- (1) Remove the rear seat cushion assembly (Refer to GROUP 52A, Rear Seat P.52A-29).
- (2) Remove the hole cover (RH).

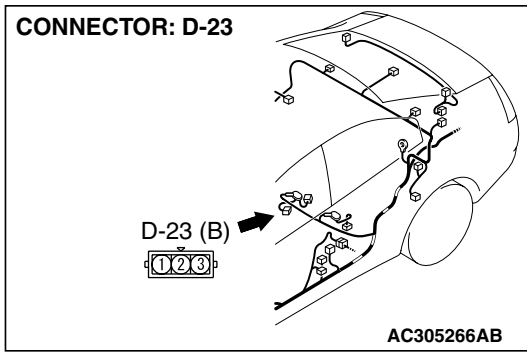
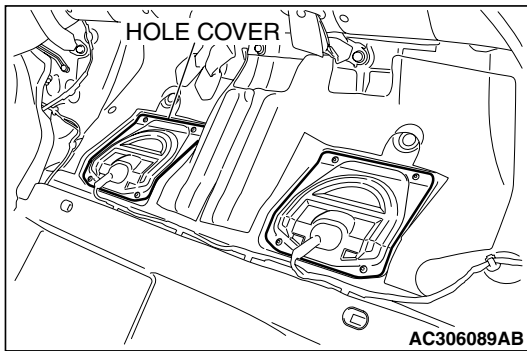

- (3) Disconnect fuel tank differential pressure sensor connector D-23.

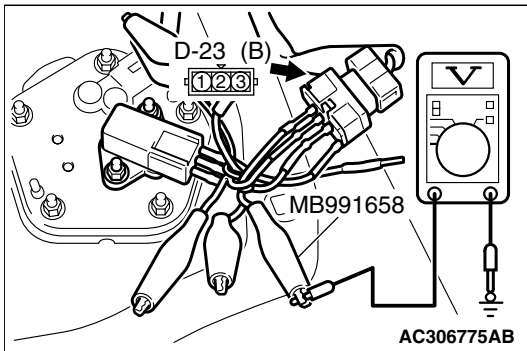

- (4) Use special tool MB991658 to connect terminals 1, 2 and 3 of the fuel tank differential pressure sensor connector D-23.
- (5) Turn the ignition switch to the "ON" position.
- (6) Remove the fuel cap.
- (7) Measure the voltage between connector D-23 terminal 1 and ground.
 - The voltage should measure between 2.0 and 3.0 volts.
- (8) Turn the ignition switch to the "LOCK" (OFF) position.

Q: Is the measured voltage between 2.0 and 3.0 volts?

- YES** : Go to Step 7.
- NO** : Go to Step 15.

STEP 7. Check PCM connector B-20, intermediate connector C-25 and fuel tank differential pressure sensor connector D-23 for loose, corroded or damaged terminals, or terminals pushed back in the connector.

Q: Are the connectors and terminals in good condition?

YES : Go to Step 8.

NO : Repair or replace the faulty components (Refer to GROUP 00E, Harness Connector Inspection [P.00E-2](#)). Then go to Step 17.

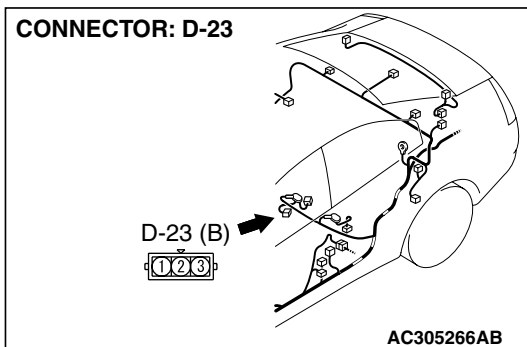
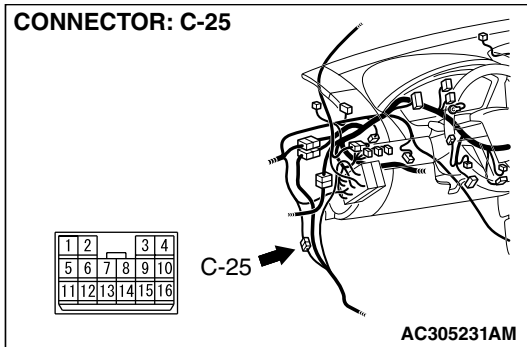
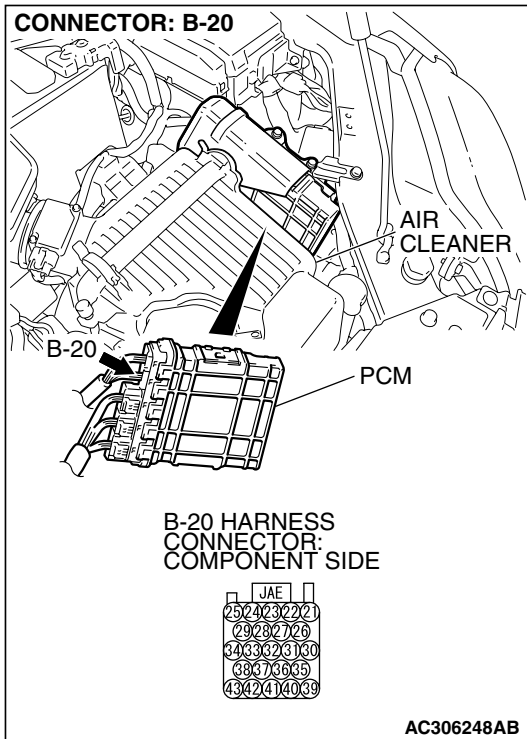

STEP 8. Check the harness wire between PCM connector B-20 terminal 23 and fuel tank differential pressure sensor connector D-23 terminal 1 for damage.

Q: Is the harness wire in good condition?

YES : This malfunction is intermittent (Refer to GROUP 00, How to Use Troubleshooting/Inspection Service Points – How to Cope with Intermittent Malfunctions [P.00-14](#)). Go to Step 17.

NO : Repair the damaged harness wire. Then go to Step 17.

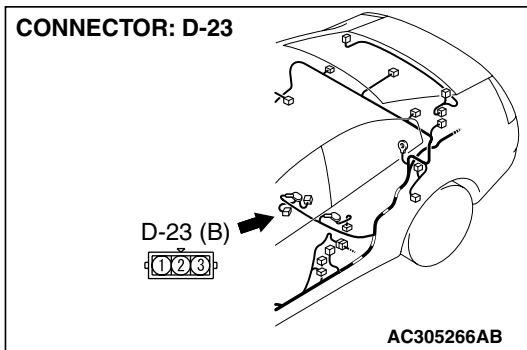
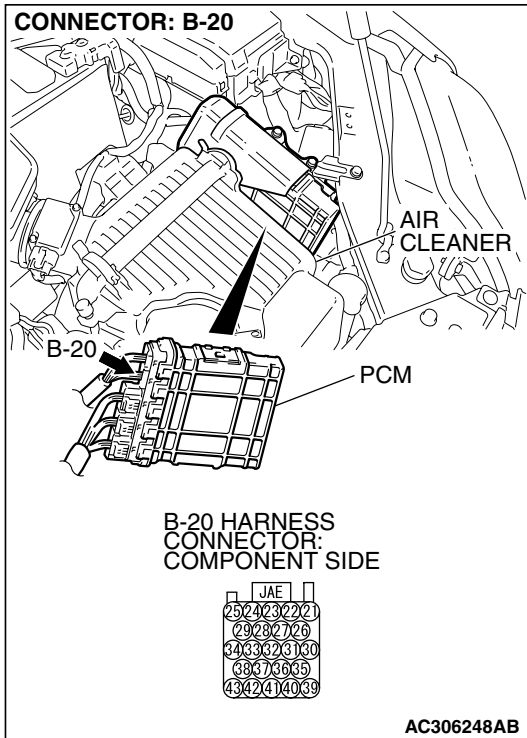

STEP 9. Measure the 5-volt reference signal at fuel tank differential pressure sensor connector D-23.

- (1) Remove the rear seat cushion assembly (Refer to GROUP 52A, Rear Seat P.52A-29).
- (2) Remove the hole cover (RH).

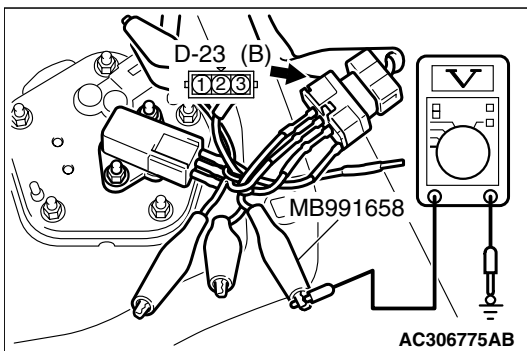
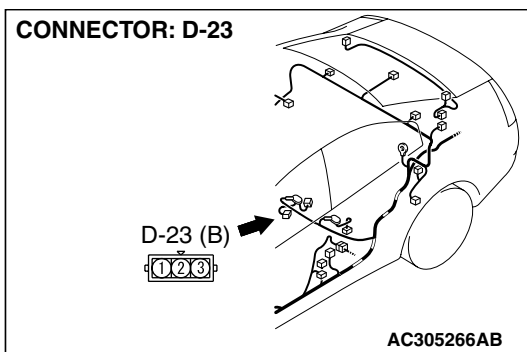
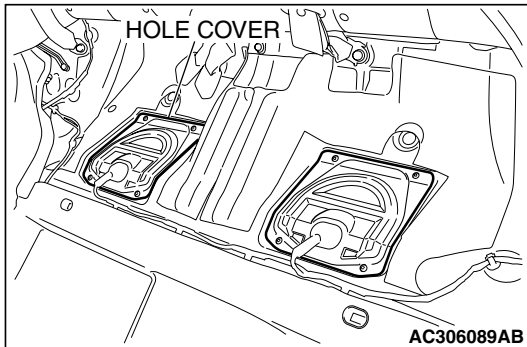

- (3) Disconnect fuel tank differential pressure sensor connector D-23.

- (4) Use special tool MB991658 to connect terminals 1,2 and 3 of the fuel tank differential pressure sensor connector D-23.
- (5) Turn the ignition switch to the "ON" position.
- (6) Measure the voltage between terminal 3 and ground.
 - The voltage should measure between 4.9 and 5.1 volts.
- (7) Turn the ignition switch to the "LOCK" (OFF) position.

Q: Is the measured voltage between 4.9 and 5.1 volts?

- YES :** Go to Step 12.
NO : Go to Step 10.

STEP 10. Check PCM connector B-20, intermediate connector C-25 and fuel tank differential pressure sensor connector D-23 for loose, corroded or damaged terminals, or terminals pushed back in the connector.

Q: Are the connectors and terminals in good condition?

YES : Go to Step 11.

NO : Repair or replace the faulty components (Refer to GROUP 00E, Harness Connector Inspection [P.00E-2](#)). Then go to Step 17.

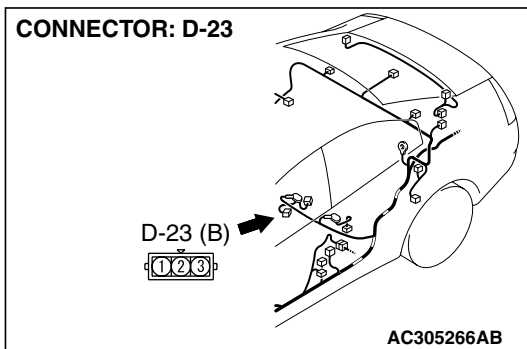
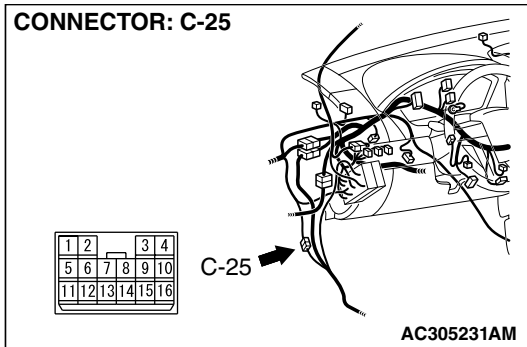
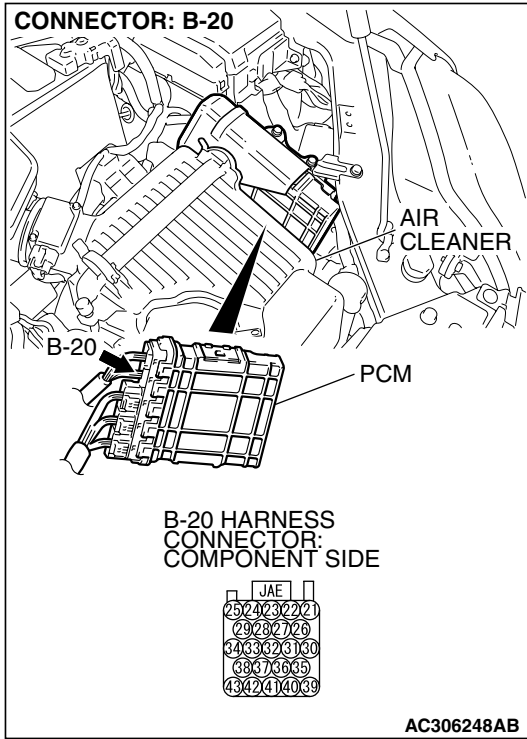

STEP 11. Check the harness wire between PCM connector B-20 terminal 21 and fuel tank differential pressure sensor connector D-23 terminal 3 for damage.

Q: Are the harness wires in good condition?

YES : It can be assumed that this malfunction is intermittent (Refer to GROUP 00, How to Use Troubleshooting/Inspection Service Points – How to Cope with Intermittent Malfunctions P.00-14). Go to Step 17.

NO : Repair the damaged harness wires. Then go to Step 17.

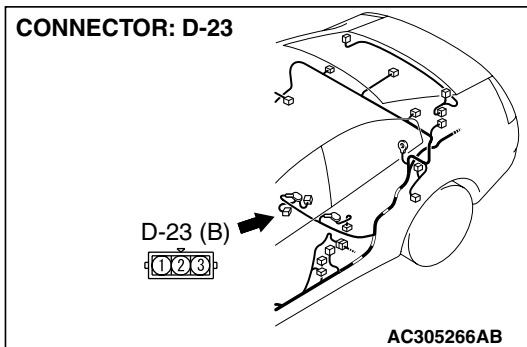
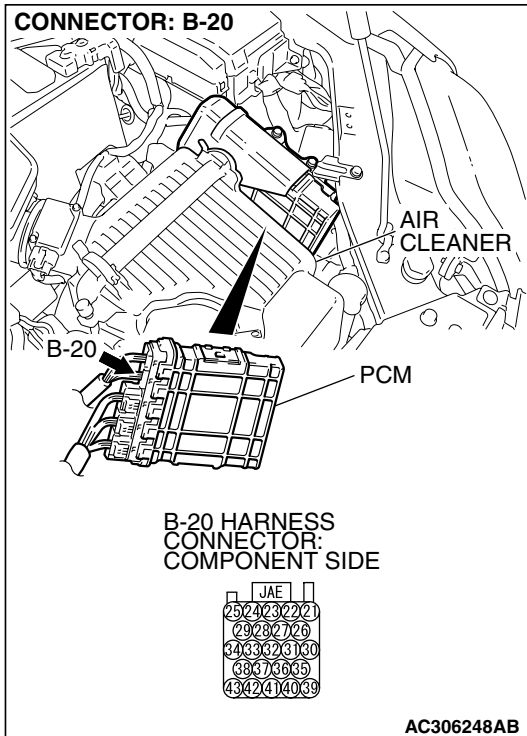

STEP 12. Measure the fuel tank differential pressure sensor return voltage at fuel tank differential pressure sensor connector D-23.

- (1) Remove the rear seat cushion assembly (Refer to GROUP 52A, Rear Seat P.52A-29).
- (2) Remove the hole cover (RH).

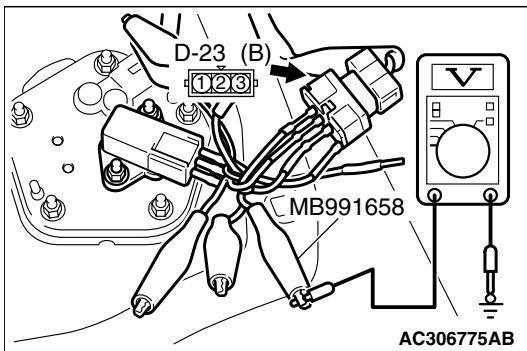
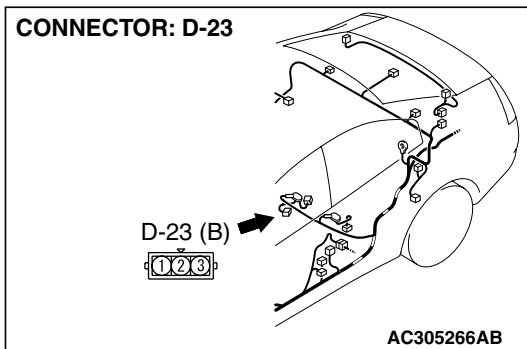
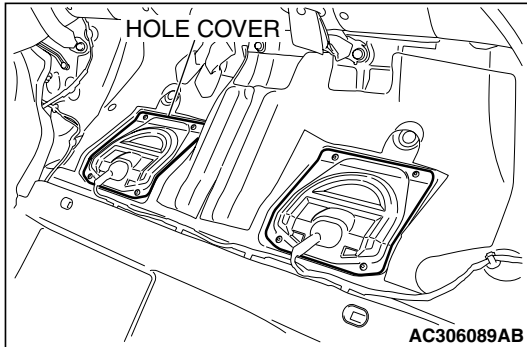

- (3) Disconnect fuel tank differential pressure sensor connector D-23.

- (4) Use special tool MB991658 to connect terminals 1,2 and 3 of the fuel tank differential pressure sensor connector D-23.
- (5) Turn the ignition switch to the "ON" position.
- (6) Measure the voltage between terminal 2 and ground.
 - The voltage should measure 0.5 volt or less.
- (7) Turn the ignition switch to the "LOCK" (OFF) position.

Q: Is the measured voltage 0.5 volt or less?

- YES** : Go to Step 13.
NO : Go to Step 17.

STEP 13. Check PCM connector B-20, intermediate connector C-25 and fuel tank differential pressure sensor connector D-23 for loose, corroded or damaged terminals, or terminals pushed back in the connector.

Q: Are the connectors and terminals in good condition?

YES : Go to Step 14.

NO : Repair or replace the faulty components (Refer to GROUP 00E, Harness Connector Inspection [P.00E-2](#)). Then go to Step 17.

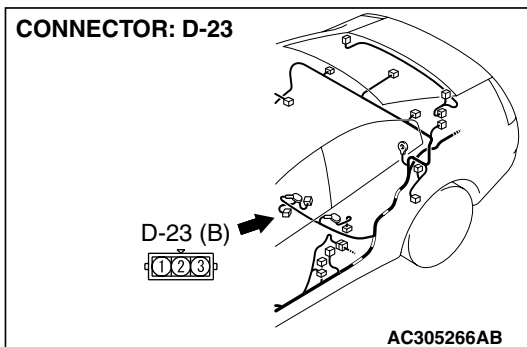
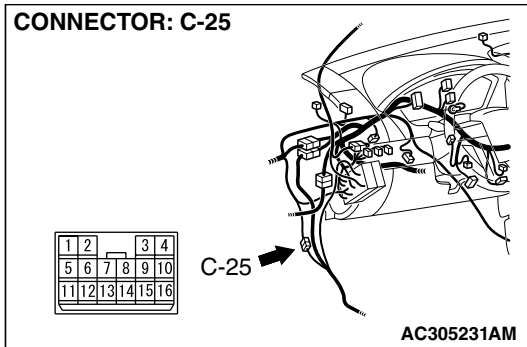
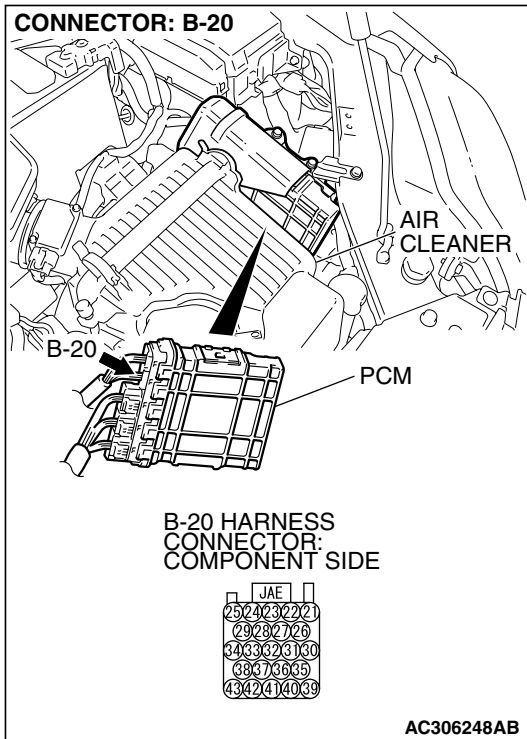

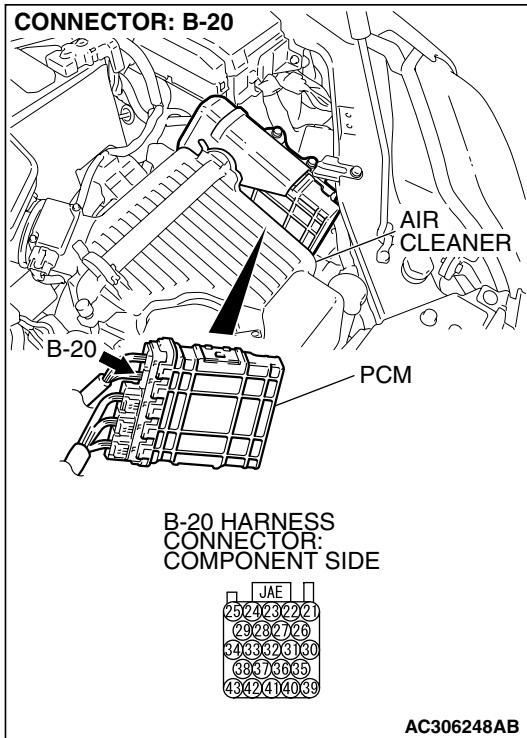

STEP 14. Check the harness wires between PCM connector B-20 terminal 22 and fuel tank differential pressure sensor connector D-23 terminal 2 for damage.
Q: Are the harness wires in good condition?

- YES :** Go to Step 17.
- NO :** Repair the damaged harness wires. Then go to Step 17.

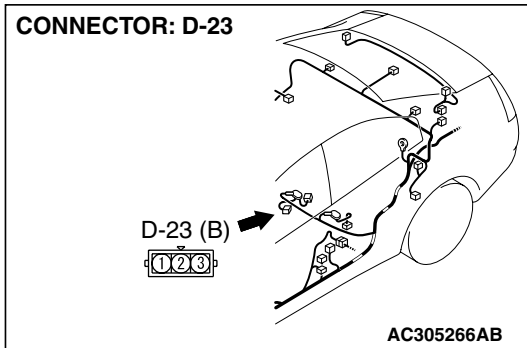

STEP 15. Check fuel tank differential pressure sensor connector D-23 for loose, corroded or damaged terminals, or terminals pushed back in the connector.

Q: Is the connectors and terminals in good condition?

- YES :** Replace the fuel tank differential pressure sensor. Then go to Step 17.
- NO :** Repair or replace the faulty components (Refer to GROUP 00E, Harness Connector Inspection [P.00E-2](#)). Then go to Step 17.

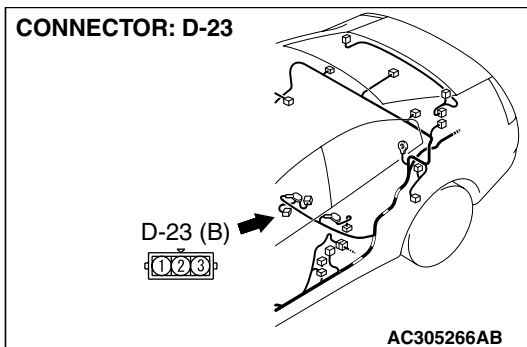

STEP 16. Using scan tool MB991958, check data list item 73: Fuel Tank Differential Pressure Sensor.

⚠ CAUTION

To prevent damage to scan tool MB991958, always turn the ignition switch to the "LOCK" (OFF) position before connecting or disconnecting scan tool MB991958.

(1) Connect scan tool MB991958 to the data link connector.

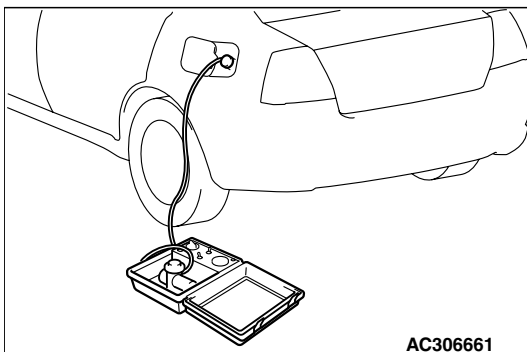
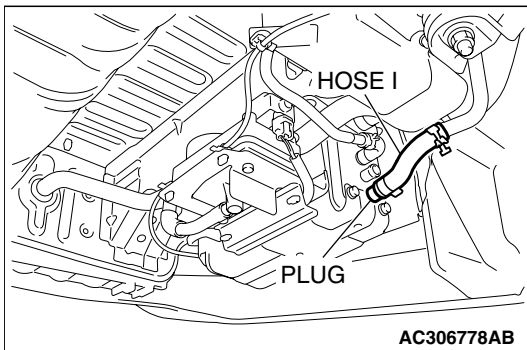
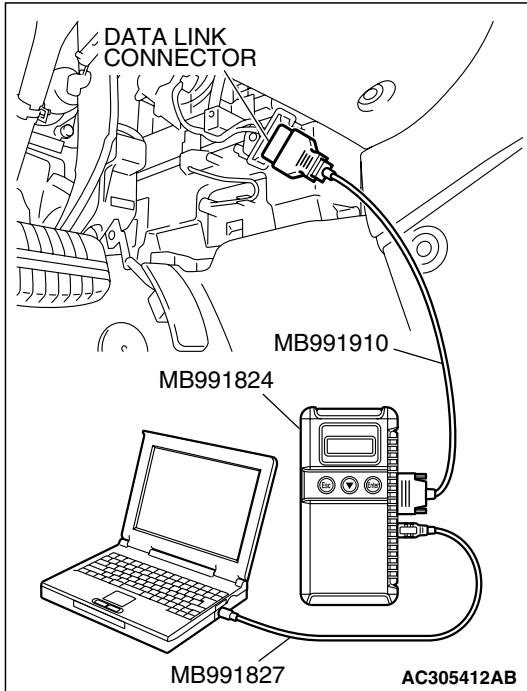

(2) Disconnect hose I from the evaporative emission canister, and plug the hose.

(3) Turn the ignition switch to the "ON" position.

(4) Remove the fuel cap.

(5) Set scan tool MB991958 to the data reading mode.

- Item 73, Fuel Tank Differential Pressure Sensor.
- The fuel tank pressure reading on the scan tool should be -1.5 to 1.5 kPa (-0.443 to 0.443 inHg).

(6) Connect the evaporative emission system pressure pump (Miller number 6872A) to the fuel tank filler tube by using fuel tank adapter (MLR-8382) and pressurize the fuel tank.

- The fuel tank pressure reading should increase.

(7) Turn the ignition switch to the "LOCK" (OFF) position. Then disconnect scan tool MB991958.

(8) Remove the evaporative emission system pressure pump (Miller number 6872A) and the fuel tank adapter (MLR-8382), and reinstall the fuel cap.

(9) Connect hose I to the evaporative emission canister.

Q: Is the fuel tank pressure between -1.5 and 1.5 kPa (-0.443 and 0.443 inHg)?

YES : It can be assumed that this malfunction is intermittent (Refer to GROUP 00, How to Use Troubleshooting/Inspection Service Points – How to Cope with Intermittent Malfunctions P.00-14). Go to Step 17.

NO : Replace the PCM (Refer to P.13A-1140). Then go to Step 17 .

STEP 17. Perform the OBD-II drive cycle.

- (1) Carry out a test drive with the drive cycle pattern (Refer to Diagnostic Function – OBD-II Drive Cycle – Procedure 1 – Evaporative Emission System Leak Monitor P.13A-6).
- (2) Read the diagnostic trouble code (DTC).

Q: Is DTC P0451 set?

YES : Repeat the troubleshooting from Step 2.

NO : The procedure is complete.

DTC P0452: Evaporative Emission System Pressure Sensor Low Input

SYSTEM DIAGRAM

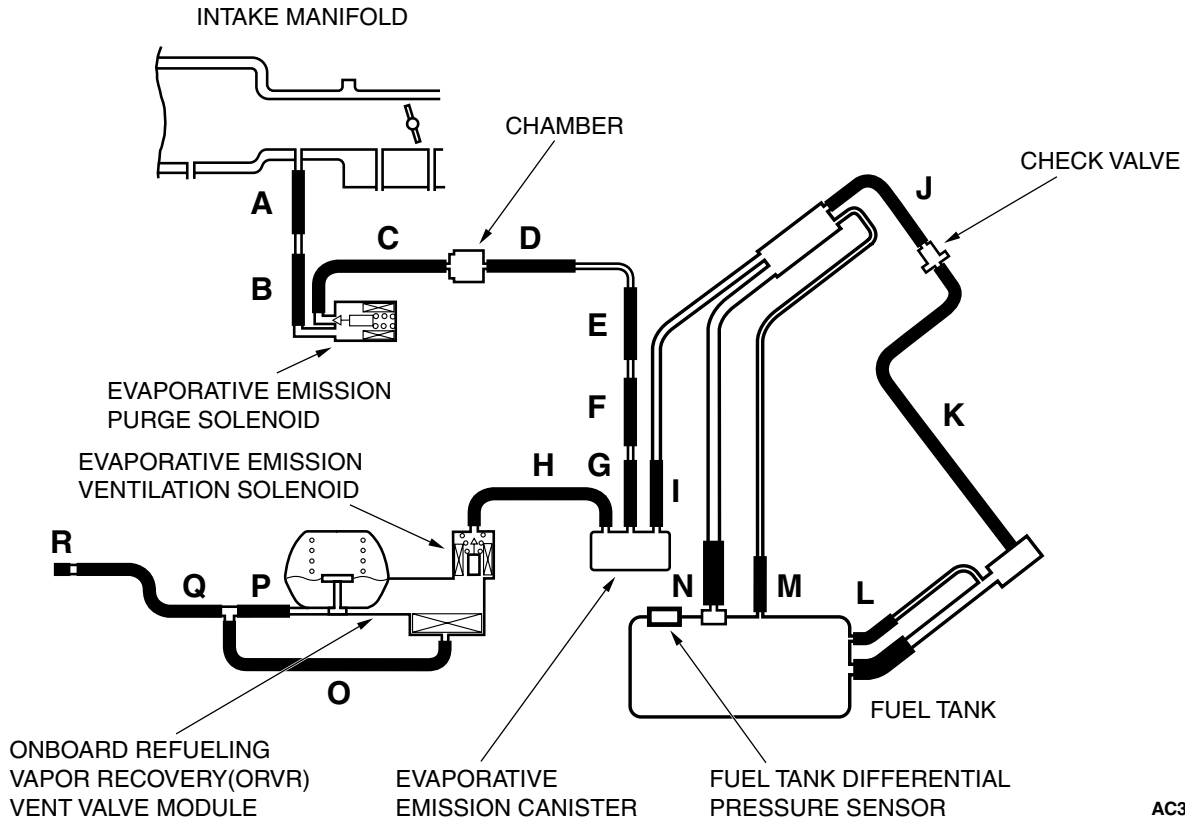

AC306277 AC

Fuel Tank Differential Pressure Sensor Circuit

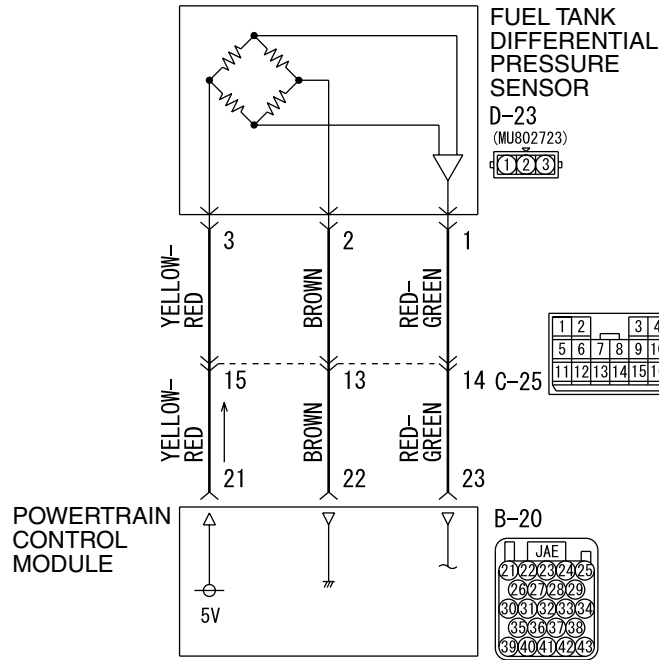

W4P13M02AA
AC306128

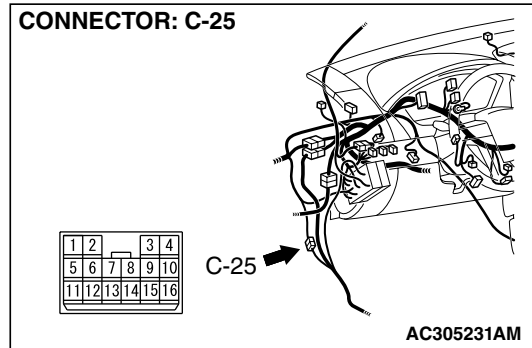
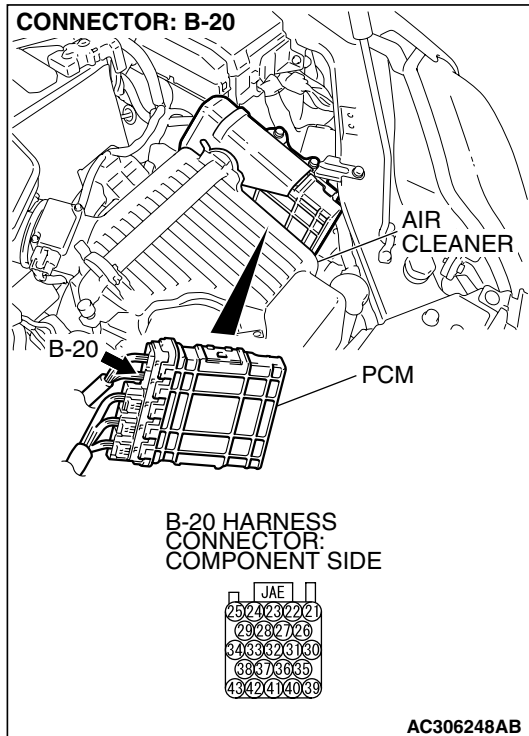

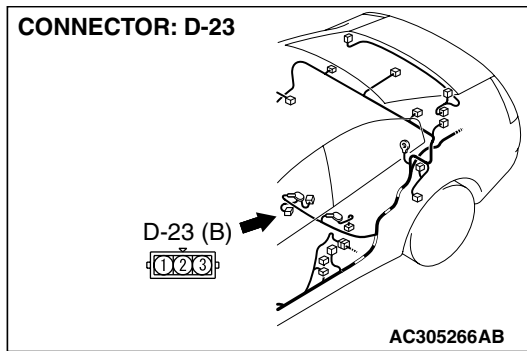

CIRCUIT OPERATION

- The PCM (terminal 21) supplies a 5-volt reference signal to the fuel tank differential pressure sensor (terminal 3). The fuel tank differential pressure sensor (terminal 2) is grounded through the PCM (terminal 22).
- The fuel tank differential pressure sensor (terminal 1) returns a voltage signal to the PCM (terminal 23) that is proportional to the pressure in the fuel tank.

TECHNICAL DESCRIPTION

- The PCM monitors the fuel tank differential pressure sensor output voltage.
- The PCM determines whether the fuel tank differential pressure sensor signal voltage is within normal operating parameters.

DESCRIPTIONS OF MONITOR METHODS

- Compare purge solenoid status with fuel tank differential pressure sensor output voltage.

MONITOR EXECUTION

- Continuous.

MONITOR EXECUTION CONDITIONS (OTHER MONITOR AND SENSOR)

Other Monitor (There is no temporary DTC stored in memory for the item monitored below)

- Evaporative emission purge solenoid monitor
- Evaporative emission ventilation solenoid monitor

Sensor (The sensors below are determined to be normal)

- Mass airflow sensor
- Barometric pressure sensor
- Intake air temperature sensor
- Engine coolant temperature sensor
- Accelerator pedal position sensor

LOGIC FLOW CHARTS (Monitor Sequence)

RANGE CHECK - MIN. / MAX.

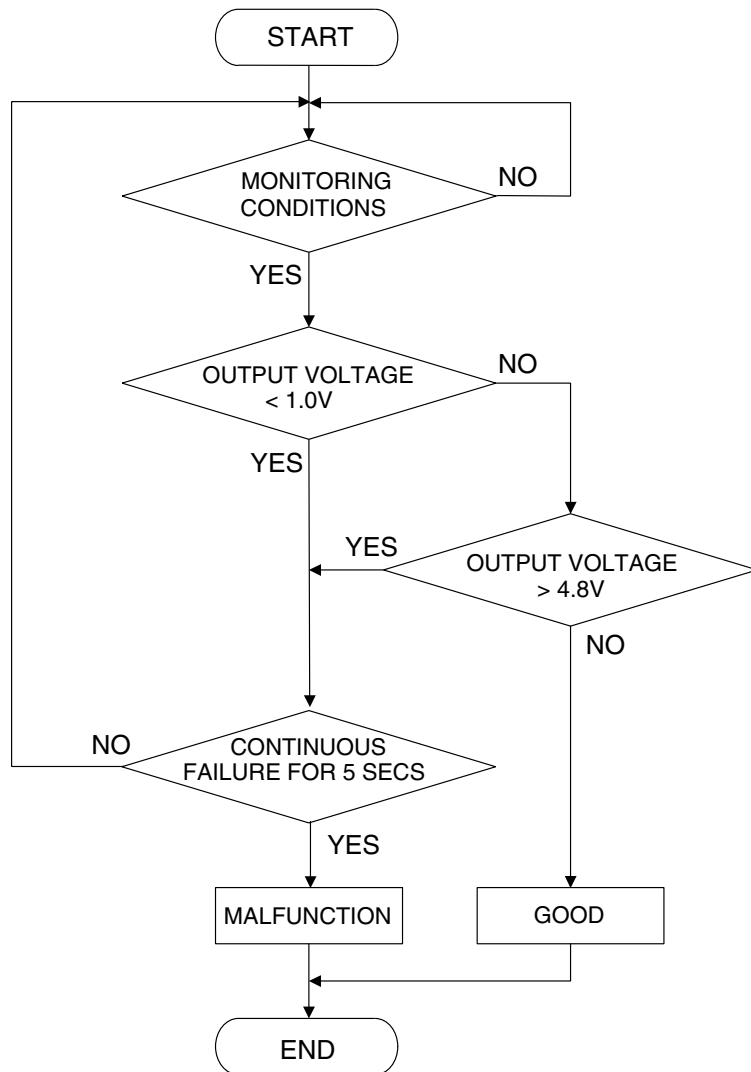

AC401447

DTC SET CONDITIONS

Check Conditions

- 2 seconds or more have passed since the starting sequence was completed.

Judgment Criteria

- The fuel tank differential pressure sensor output voltage remains 0.2 volt or less for 5 seconds.

OBD-II DRIVE CYCLE PATTERN

Refer to Diagnostic Function – OBD-II Drive Cycle – Procedure 1 – Evaporative Emission System Leak Monitor [P. 13A-6](#).

TROUBLESHOOTING HINTS (THE MOST LIKELY CAUSES FOR THIS CODE TO BE SET ARE:)

- Malfunction of the fuel tank differential pressure sensor.
- A damaged harness in the fuel tank differential pressure sensor circuit.
- Malfunction of the PCM.

OVERVIEW OF TROUBLESHOOTING

- DTC P0452 can be set by a faulty fuel tank differential pressure sensor or related circuit, or PCM failure.
- To check for system blockage, do a performance test which uses a mechanical vacuum gauge and scan tool MB991958 set on the fuel tank differential pressure sensor (TANK PRS SNSR 73). The mechanical gauge reading is used to verify scan tool MB991958 reading. A comparison of the mechanical gauge with the reading on scan tool MB991958 will locate a problem in the system.

DIAGNOSIS**Required Special Tools:**

- MB991958: Scan Tool (MUT-III Sub Assembly)
 - MB991824: V.C.I.
 - MB991827: MUT-III USB Cable
 - MB991910: MUT-III Main Harness A
- MB991658: Test Harness Set
- MB991923: Power Plant ECU Check Harness

STEP 1. Using scan tool MB991958, check data list item 73: Fuel Tank Differential Pressure Sensor.

CAUTION

To prevent damage to scan tool MB991958, always turn the ignition switch to the "LOCK" (OFF) position before connecting or disconnecting scan tool MB991958.

(1) Connect scan tool MB991958 to the data link connector.

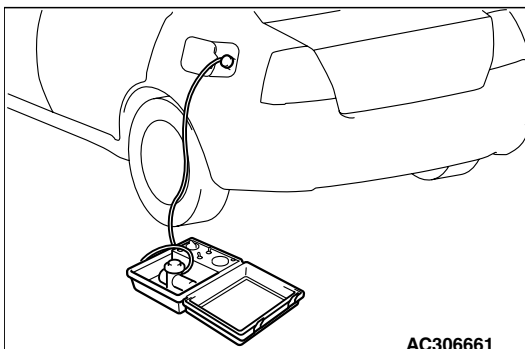
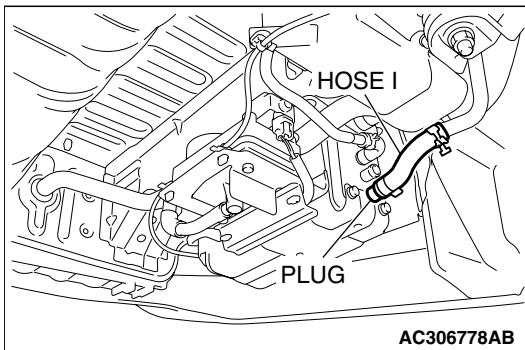
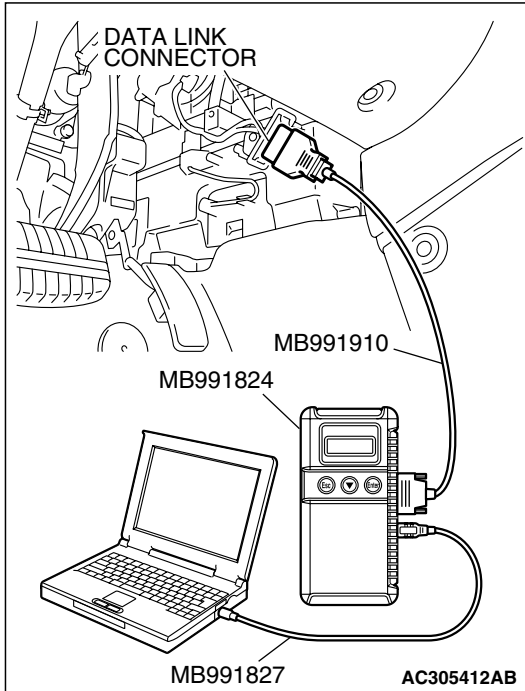

(2) Disconnect hose I from the evaporative emission canister, and plug the hose.

(3) Turn the ignition switch to the "ON" position.

(4) Remove the fuel cap.

(5) Set scan tool MB991958 to the data reading mode.

- Item 73, Fuel Tank Differential Pressure Sensor.
- The fuel tank pressure reading on the scan tool should be -1.5 to 1.5 kPa (-0.443 to 0.443 inHg).

(6) Connect the evaporative emission system pressure pump (Miller number 6872A) to the fuel tank filler tube by using fuel tank adapter (MLR-8382) and pressurize the fuel tank.

- The fuel tank pressure reading should increase.

(7) Turn the ignition switch to the "LOCK" (OFF) position. Then disconnect scan tool MB991958.

(8) Remove the evaporative emission system pressure pump (Miller number 6872A) and the fuel tank adapter (MLR-8382), and reinstall the fuel cap.

(9) Connect hose I to the evaporative emission canister.

Q: Is the fuel tank pressure between -1.5 and 1.5 kPa (-0.443 and 0.443 inHg)?

YES : It can be assumed that this malfunction is intermittent (Refer to GROUP 00, How to Use Troubleshooting/Inspection Service Points – How to Cope with Intermittent Malfunctions P.00-14). Go to Step 17.

NO : Go to Step 2.

STEP 2. Measure the sensor output voltage at PCM connector B-20 by using check harness special tool MB991923.

(1) Disconnect all the connectors from the PCM.

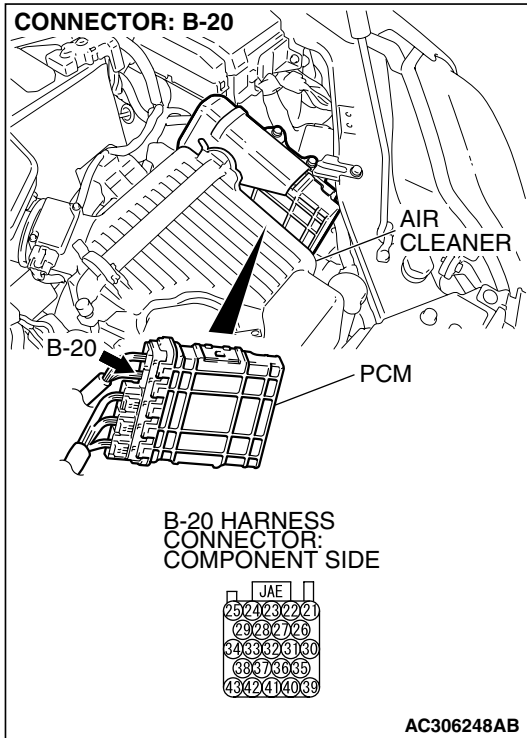

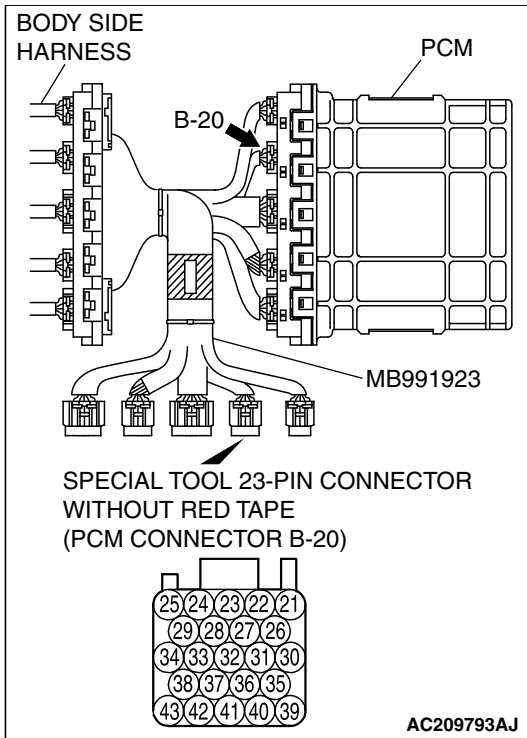

- (2) Connect special tool MB991923 (check harness) between the PCM and the body-side harness connector.
- (3) Turn the ignition switch to the "ON" position.
- (4) Remove the fuel cap.

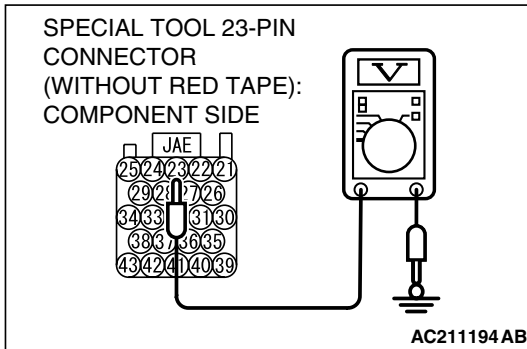

- (5) Measure the voltage between terminal 23 and ground.
 - The voltage should measure between 2.0 and 3.0 volts.
- (6) Install the fuel cap.
- (7) Turn the ignition switch to the "LOCK" (OFF) position.

Q: Is the measured voltage between 2.0 and 3.0 volts?

- YES :** Go to Step 16.
NO : Go to Step 3.

STEP 3. Measure the 5-volt reference signal at PCM connector B-20 by using check harness special tool MB991923.

(1) Disconnect all the connectors from the PCM.

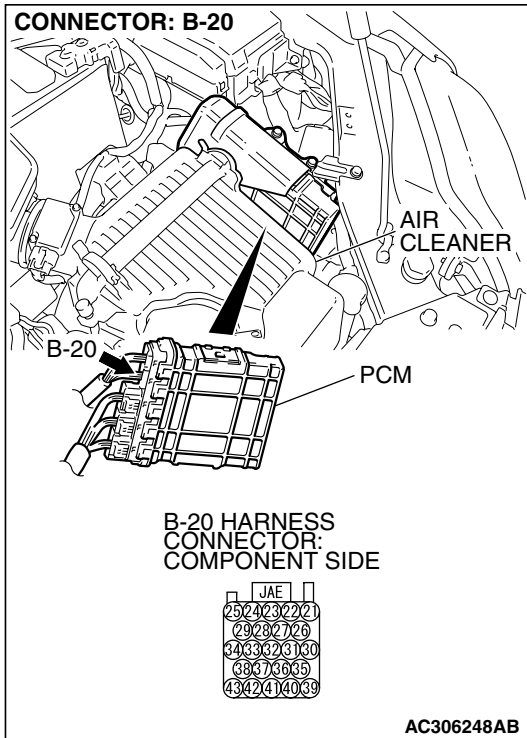

- (2) Connect special tool MB991923 (check harness) between the PCM and the body-side harness connector.
- (3) Turn the ignition switch to the "ON" position.

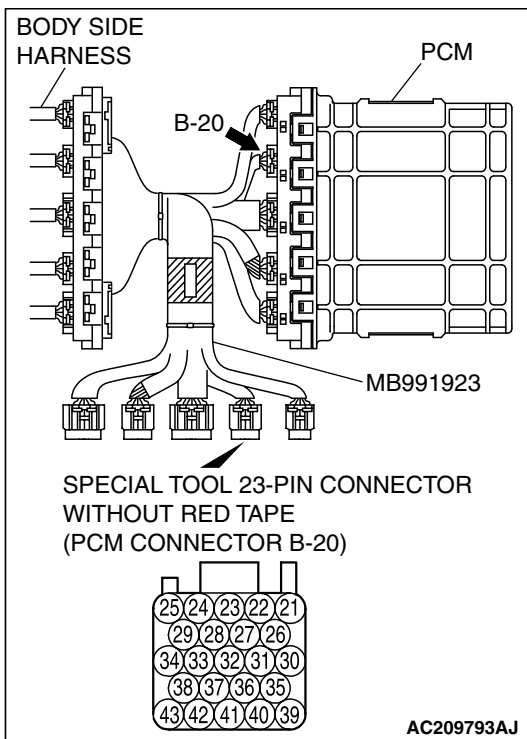

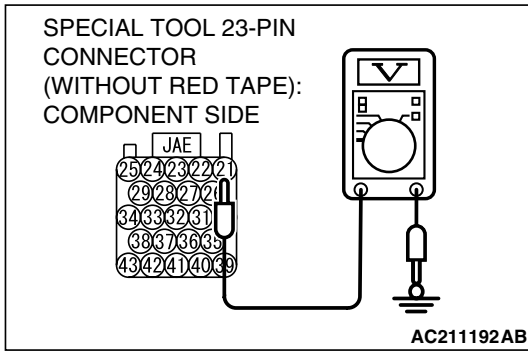

- (4) Measure the voltage between terminal 21 and ground.
• The voltage should measure between 4.9 and 5.1 volts.
(5) Turn the ignition switch to the "LOCK" (OFF) position.

Q: Is the measured voltage between 4.9 and 5.1 volts?

- YES :** Go to Step 5.
NO : Go to Step 4.

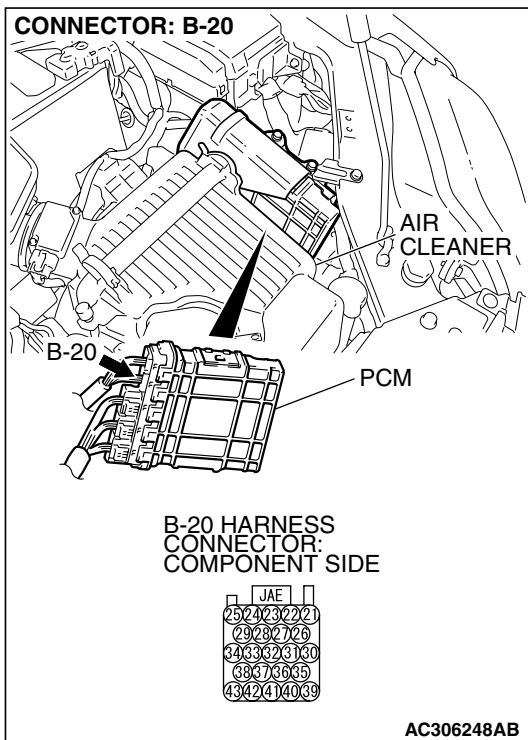

STEP 4. Check PCM connector B-20 for loose, corroded or damaged terminals, or terminals pushed back in the connector.

Q: Are the connector and terminals in good condition?

- YES :** Go to Step 16.
NO : Repair or replace the faulty components (Refer to GROUP 00E, Harness Connector Inspection [P.00E-2](#)). Then go to Step 17.

STEP 5. Measure the sensor output voltage at PCM connector B-20 by using check harness special tool MB991923.

(1) Disconnect all the connectors from the PCM.

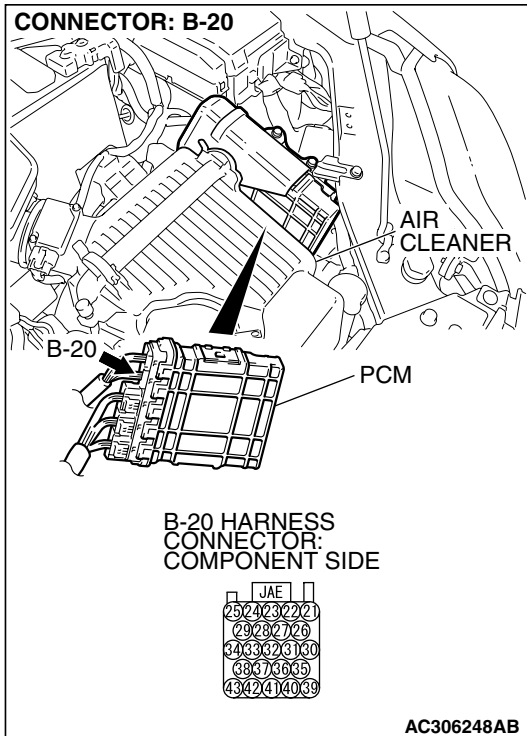

- (2) Connect special tool MB991923 (check harness) between the PCM and the body-side harness connector.
- (3) Turn the ignition switch to the "ON" position.
- (4) Remove the fuel cap.

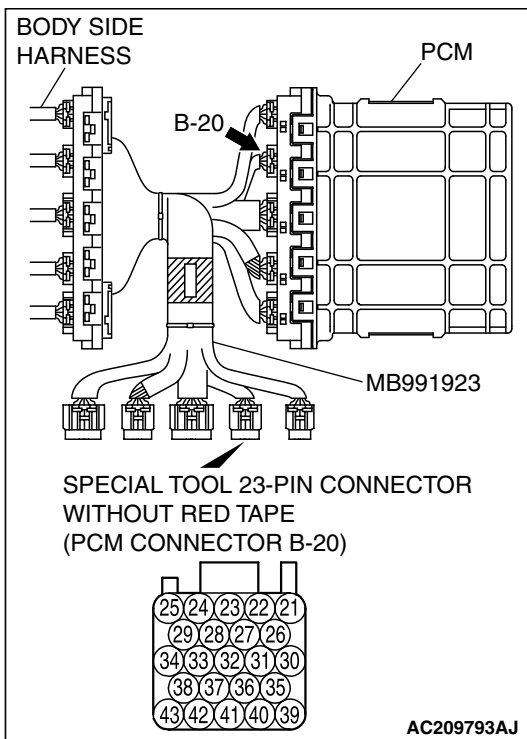

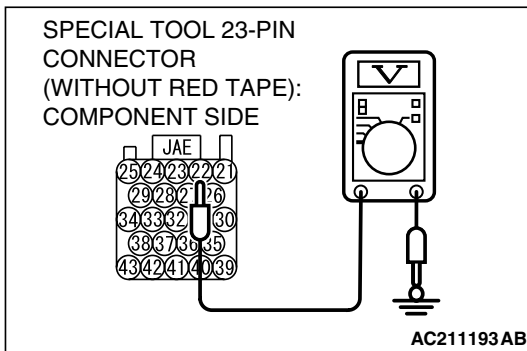

- (5) Measure the voltage between terminal 22 and ground.
 - The voltage should measure 0.5 volt or less.
- (6) Install the fuel cap.
- (7) Turn the ignition switch to the "LOCK" (OFF) position.

Q: Is the measured voltage 0.5 volt or less?

- YES :** Go to Step 6.
NO : Go to Step 9.

STEP 6. Measure the signal voltage at intermediate connector D-23.

- (1) Remove the rear seat cushion assembly (Refer to GROUP 52A, Rear Seat P.52A-29).
- (2) Remove the hole cover (RH).

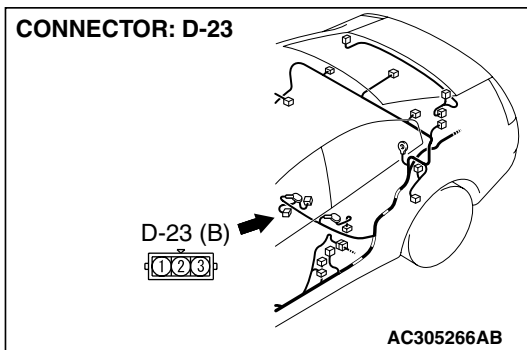
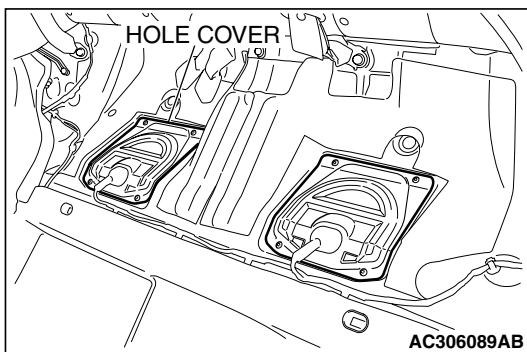

- (3) Disconnect fuel tank differential pressure sensor connector D-23.

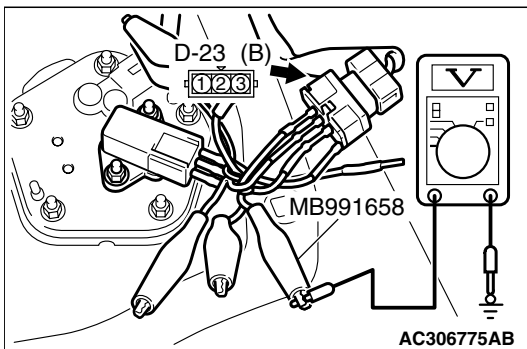

- (4) Use special tool MB991658 to connect terminals 1, 2 and 3 of the fuel tank differential pressure sensor connector D-23.
- (5) Turn the ignition switch to the "ON" position.
- (6) Remove the fuel cap.
- (7) Measure the voltage between connector D-23 terminal 1 and ground.
 - The voltage should measure between 2.0 and 3.0 volts.
- (8) Turn the ignition switch to the "LOCK" (OFF) position.

Q: Is the measured voltage between 2.0 and 3.0 volts?

- YES :** Go to Step 7.
NO : Go to Step 15.

STEP 7. Check PCM connector B-20, intermediate connector C-25 and fuel tank differential pressure sensor connector D-23 for loose, corroded or damaged terminals, or terminals pushed back in the connector.

Q: Are the connectors and terminals in good condition?

YES : Go to Step 8.

NO : Repair or replace the faulty components (Refer to GROUP 00E, Harness Connector Inspection [P.00E-2](#)). Then go to Step 17.

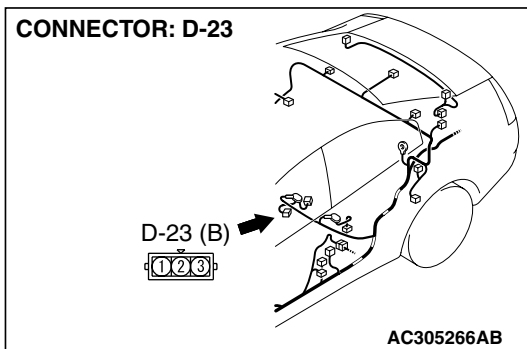
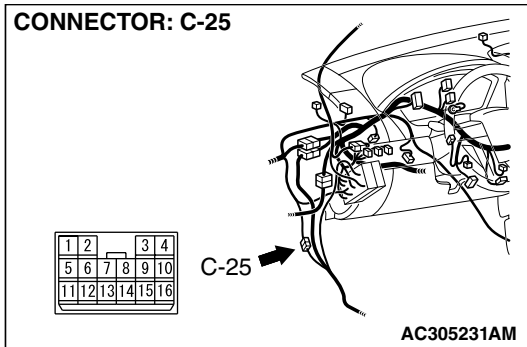
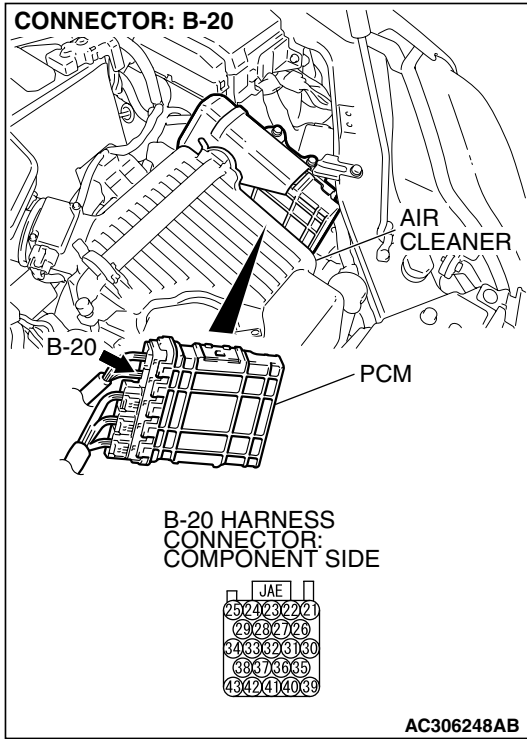

STEP 8. Check the harness wire between PCM connector B-20 terminal 23 and fuel tank differential pressure sensor connector D-23 terminal 1 for damage.

Q: Is the harness wire in good condition?

YES : This malfunction is intermittent (Refer to GROUP 00, How to Use Troubleshooting/Inspection Service Points – How to Cope with Intermittent Malfunctions [P.00-14](#)). Go to Step 17.

NO : Repair the damaged harness wire. Then go to Step 17.

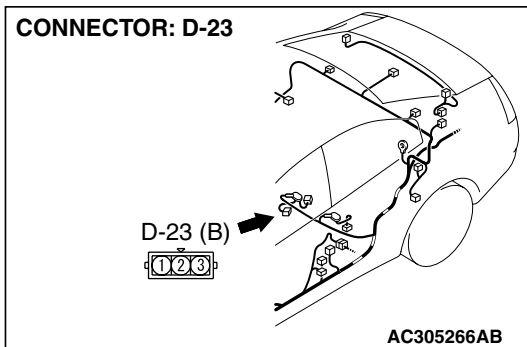
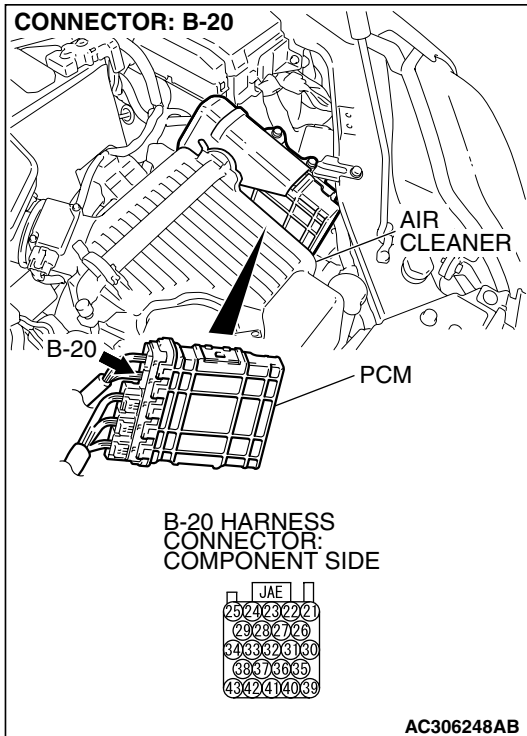

STEP 9. Measure the 5-volt reference signal at fuel tank differential pressure sensor connector D-23.

- (1) Remove the rear seat cushion assembly (Refer to GROUP 52A, Rear Seat P.52A-29).
- (2) Remove the hole cover (RH).

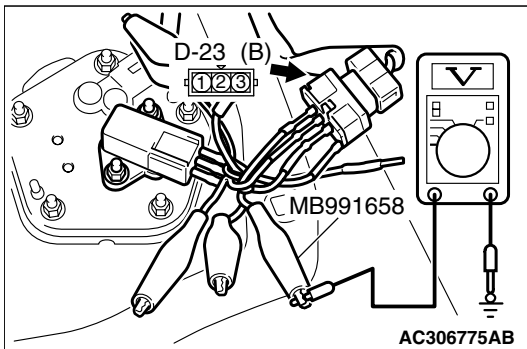
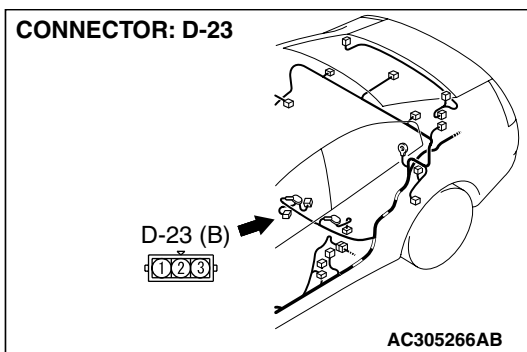
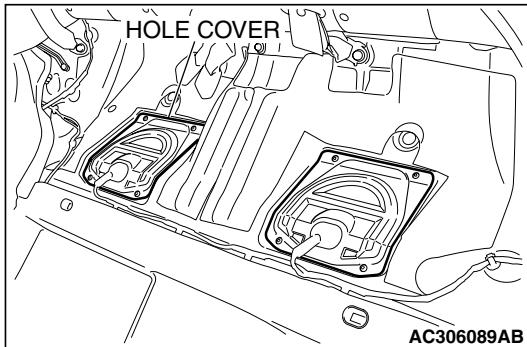

- (3) Disconnect fuel tank differential pressure sensor connector D-23.

- (4) Use special tool MB991658 to connect terminals 1,2 and 3 of the fuel tank differential pressure sensor connector D-23.
- (5) Turn the ignition switch to the "ON" position.
- (6) Measure the voltage between terminal 3 and ground.
 - The voltage should measure between 4.9 and 5.1 volts.
- (7) Turn the ignition switch to the "LOCK" (OFF) position.

Q: Is the measured voltage between 4.9 and 5.1 volts?

- YES :** Go to Step 12.
NO : Go to Step 10.

STEP 10. Check PCM connector B-20, intermediate connector C-25 and fuel tank differential pressure sensor connector D-23 for loose, corroded or damaged terminals, or terminals pushed back in the connector.

Q: Are the connectors and terminals in good condition?

YES : Go to Step 11.

NO : Repair or replace the faulty components (Refer to GROUP 00E, Harness Connector Inspection P.00E-2). Then go to Step 17.

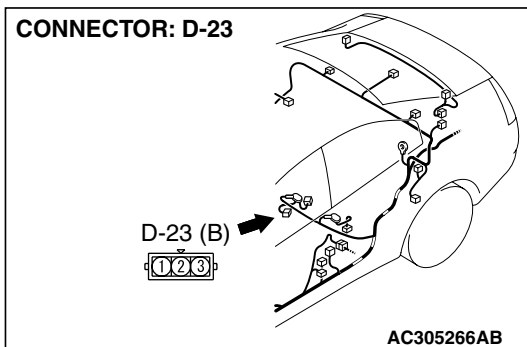
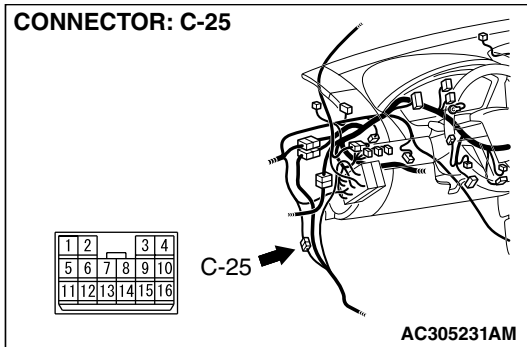
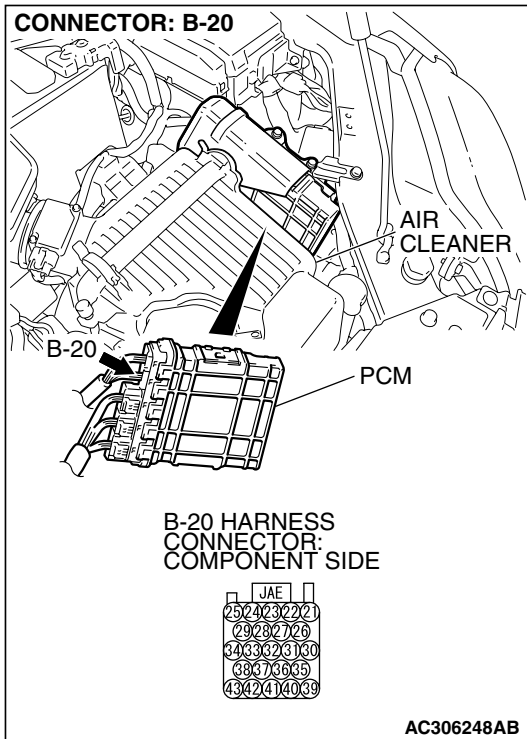

STEP 11. Check the harness wire between PCM connector B-20 terminal 21 and fuel tank differential pressure sensor connector D-23 terminal 3 for damage.

Q: Are the harness wires in good condition?

YES : It can be assumed that this malfunction is intermittent (Refer to GROUP 00, How to Use Troubleshooting/Inspection Service Points – How to Cope with Intermittent Malfunctions P.00-14). Go to Step 17.

NO : Repair the damaged harness wires. Then go to Step 17.

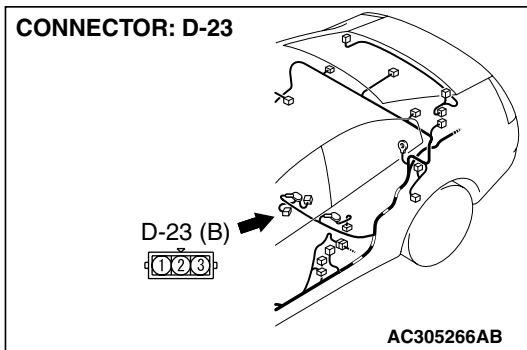
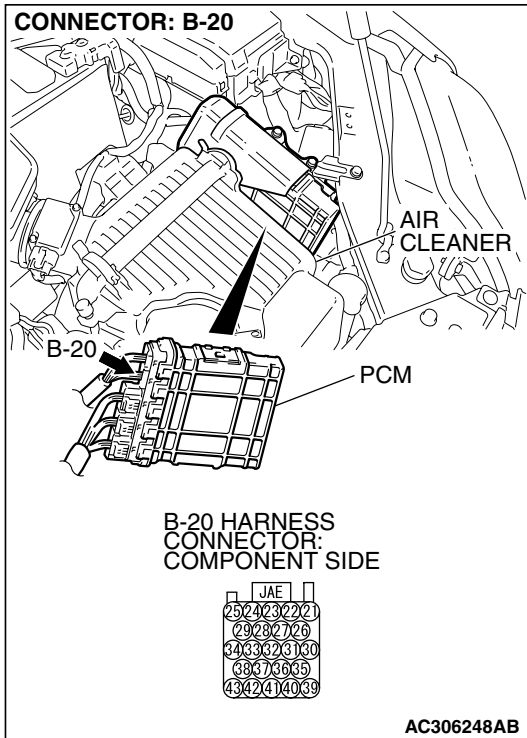

STEP 12. Measure the fuel tank differential pressure sensor return voltage at fuel tank differential pressure sensor connector D-23.

- (1) Remove the rear seat cushion assembly (Refer to GROUP 52A, Rear Seat P.52A-29).
- (2) Remove the hole cover (RH).

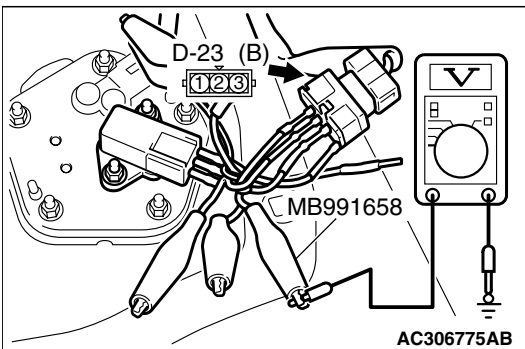
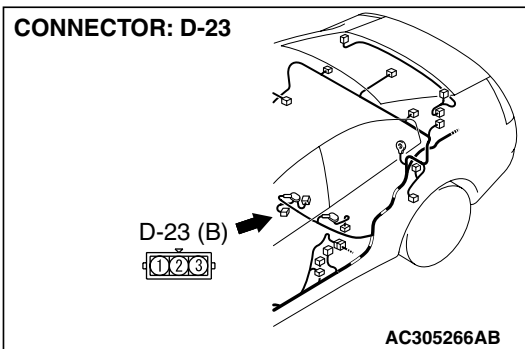
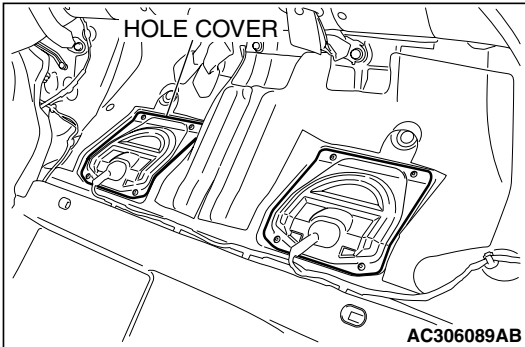

- (3) Disconnect fuel tank differential pressure sensor connector D-23.

- (4) Use special tool MB991658 to connect terminals 1,2 and 3 of the fuel tank differential pressure sensor connector D-23.
- (5) Turn the ignition switch to the "ON" position.
- (6) Measure the voltage between terminal 2 and ground.
 - The voltage should measure 0.5 volt or less.
- (7) Turn the ignition switch to the "LOCK" (OFF) position.

Q: Is the measured voltage 0.5 volt or less?

- YES :** Go to Step 13.
NO : Go to Step 17.

STEP 13. Check PCM connector B-20, intermediate connector C-25 and fuel tank differential pressure sensor connector D-23 for loose, corroded or damaged terminals, or terminals pushed back in the connector.

Q: Are the connectors and terminals in good condition?

YES : Go to Step 14.

NO : Repair or replace the faulty components (Refer to GROUP 00E, Harness Connector Inspection [P.00E-2](#)). Then go to Step 17.

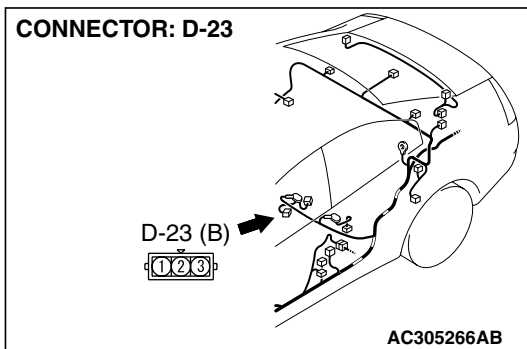
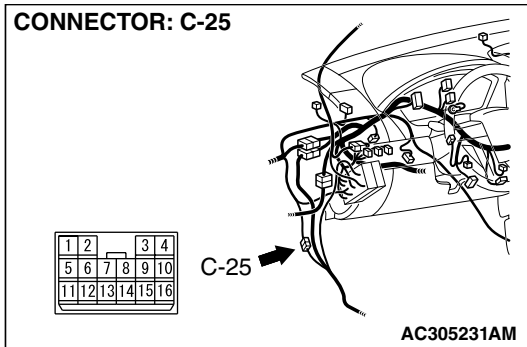
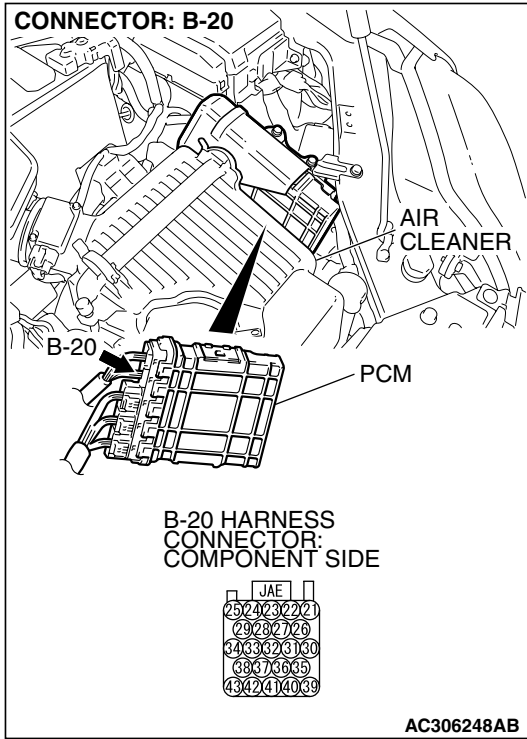

STEP 14. Check the harness wires between PCM connector B-20 terminal 22 and fuel tank differential pressure sensor connector D-23 terminal 2 for damage.
Q: Are the harness wires in good condition?

YES : Go to Step 17.

NO : Repair the damaged harness wires. Then go to Step 17.

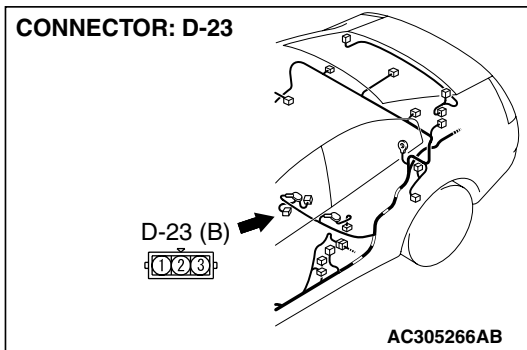
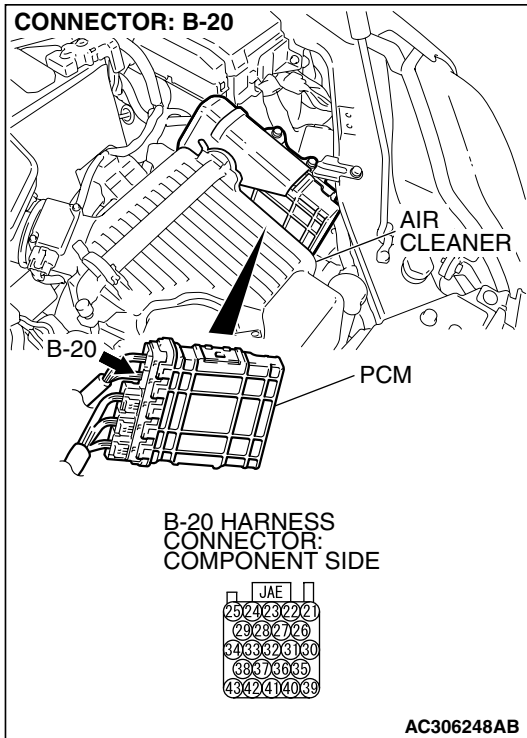

STEP 15. Check fuel tank differential pressure sensor connector D-23 for loose, corroded or damaged terminals, or terminals pushed back in the connector.

Q: Is the connectors and terminals in good condition?

YES : Replace the fuel tank differential pressure sensor. Then go to Step 17.

NO : Repair or replace the faulty components (Refer to GROUP 00E, Harness Connector Inspection [P.00E-2](#)). Then go to Step 17.

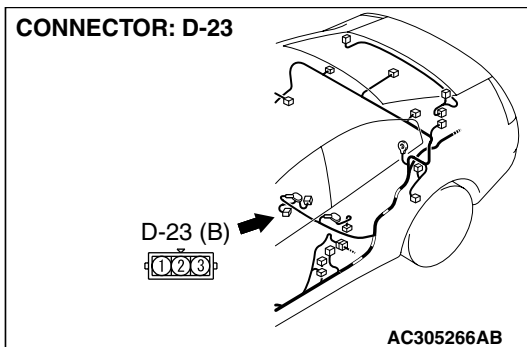

STEP 16. Using scan tool MB991958, check data list item 73: Fuel Tank Differential Pressure Sensor.

⚠ CAUTION

To prevent damage to scan tool MB991958, always turn the ignition switch to the "LOCK" (OFF) position before connecting or disconnecting scan tool MB991958.

(1) Connect scan tool MB991958 to the data link connector.

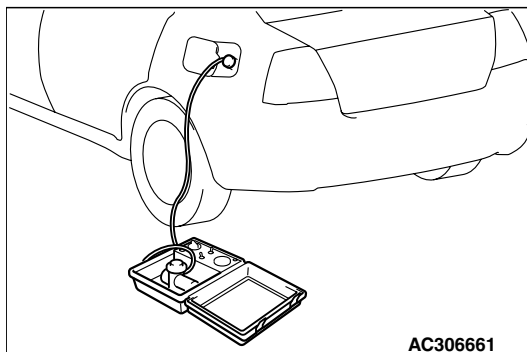
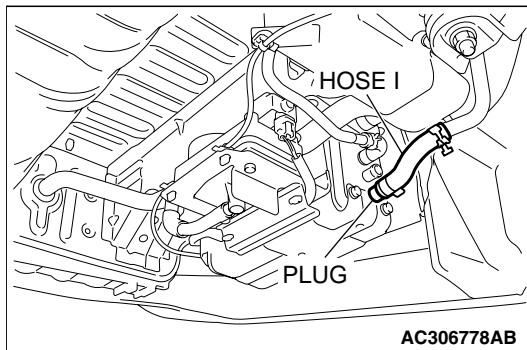
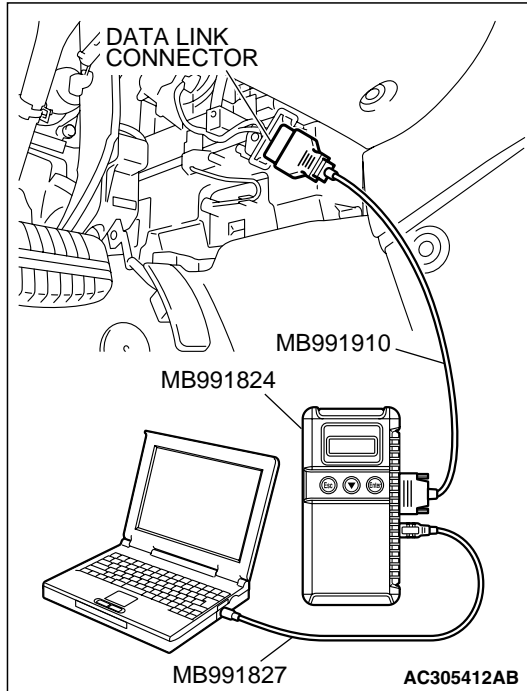

(2) Disconnect hose I from the evaporative emission canister, and plug the hose.

(3) Turn the ignition switch to the "ON" position.

(4) Remove the fuel cap.

(5) Set scan tool MB991958 to the data reading mode.

- Item 73, Fuel Tank Differential Pressure Sensor.
- The fuel tank pressure reading on the scan tool should be -1.5 to 1.5 kPa (-0.443 to 0.443 inHg).

(6) Connect the evaporative emission system pressure pump (Miller number 6872A) to the fuel tank filler tube by using fuel tank adapter (MLR-8382) and pressurize the fuel tank.

- The fuel tank pressure reading should increase.

(7) Turn the ignition switch to the "LOCK" (OFF) position. Then disconnect scan tool MB991958.

(8) Remove the evaporative emission system pressure pump (Miller number 6872A) and the fuel tank adapter (MLR-8382), and reinstall the fuel cap.

(9) Connect hose I to the evaporative emission canister.

Q: Is the fuel tank pressure between -1.5 and 1.5 kPa (-0.443 and 0.443 inHg)?

YES : It can be assumed that this malfunction is intermittent (Refer to GROUP 00, How to Use Troubleshooting/Inspection Service Points – How to Cope with Intermittent Malfunctions P.00-14). Go to Step 17.

NO : Replace the PCM (Refer to P.13A-1140). Then go to Step 17.

STEP 17. Perform the OBD-II drive cycle.

- (1) Carry out a test drive with the drive cycle pattern (Refer to Diagnostic Function – OBD-II Drive Cycle – Procedure 1 – Evaporative Emission System Leak Monitor P.13A-6).
- (2) Read the diagnostic trouble code (DTC).

Q: Is DTC P0452 set?

YES : Repeat the troubleshooting from Step 2.

NO : The procedure is complete.

DTC P0453: Evaporative Emission System Pressure Sensor High Input

SYSTEM DIAGRAM

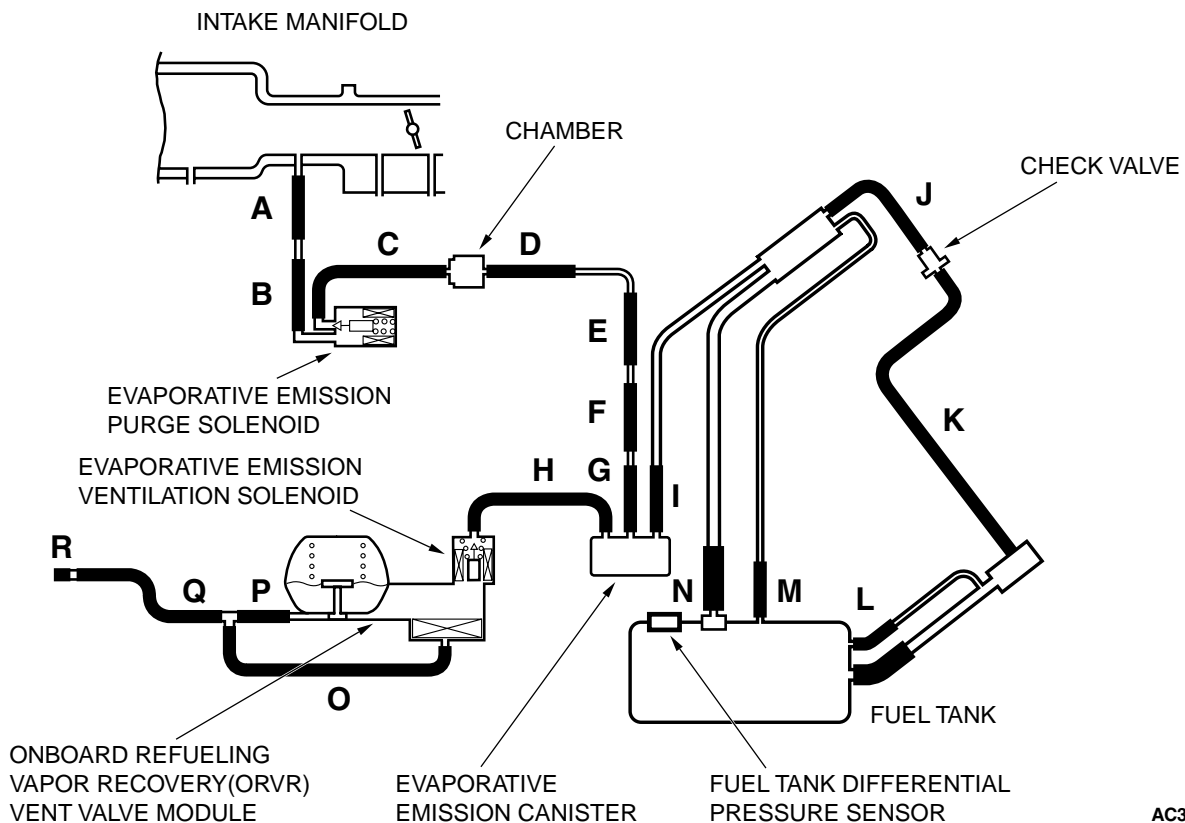

AC306277 AC

Fuel Tank Differential Pressure Sensor Circuit

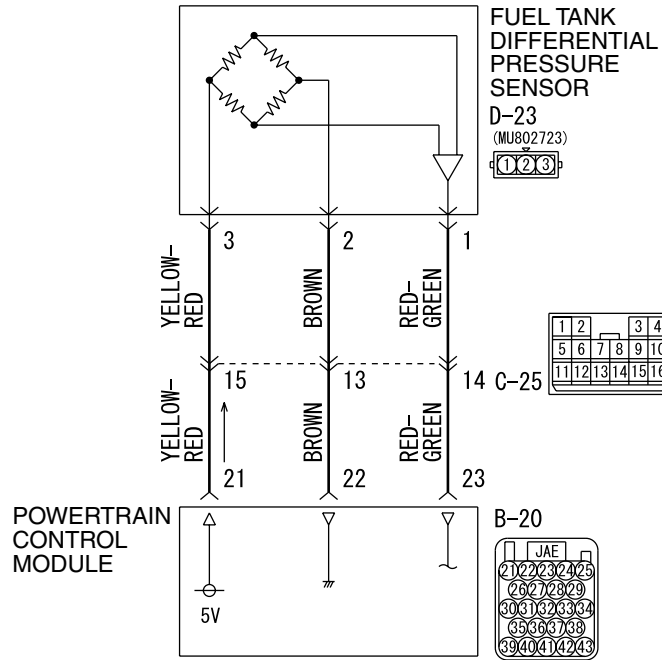

W4P13M02AA
AC306128

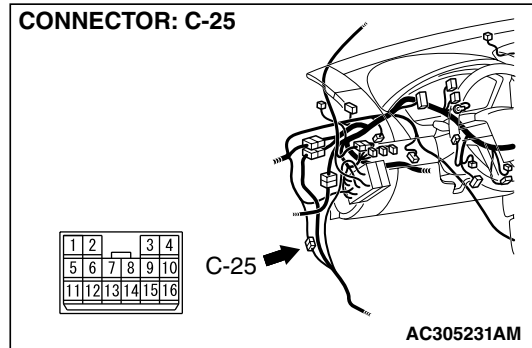
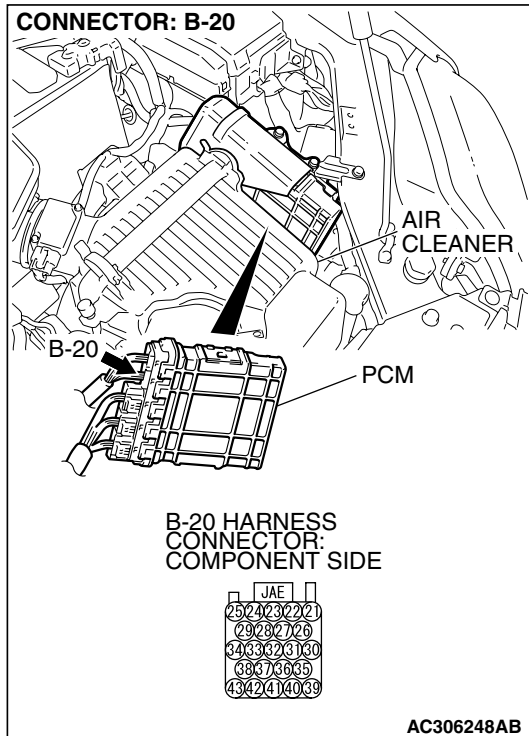

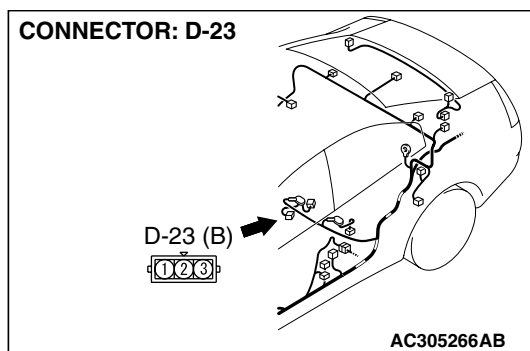

CIRCUIT OPERATION

- The PCM (terminal 21) supplies a 5-volt reference voltage to the fuel tank differential pressure sensor (terminal 3). The PCM (terminal 22) supplies a ground to the fuel tank differential pressure sensor (terminal 2).
- The PCM (terminal 23) receives a voltage signal proportional to the pressure in the fuel tank from the fuel tank differential pressure sensor (terminal 1).

TECHNICAL DESCRIPTION

- To determine whether the fuel tank differential pressure sensor is defective, the PCM monitors the fuel tank differential pressure sensor output voltage.
- The PCM judges if the fuel tank differential pressure sensor output voltage is normal.

NOTE: In rare cases, this DTC may be also set under some fuel and driving conditions regardless of the fuel pressure sensor output voltage when the fuel system is clogged.

DESCRIPTIONS OF MONITOR METHODS

- Compare purge solenoid status with fuel tank differential pressure sensor output voltage.

MONITOR EXECUTION

- Continuous.

MONITOR EXECUTION CONDITIONS (OTHER MONITOR AND SENSOR)

Other Monitor (There is no temporary DTC stored in memory for the item monitored below)

- Evaporative emission purge solenoid monitor
- Evaporative emission ventilation solenoid monitor

Sensor (The sensors below are determined to be normal)

- Mass airflow sensor
- Barometric pressure sensor
- Intake air temperature sensor
- Engine coolant temperature sensor
- Accelerator pedal position sensor

LOGIC FLOW CHARTS (Monitor Sequence)

RANGE CHECK - MIN. / MAX.

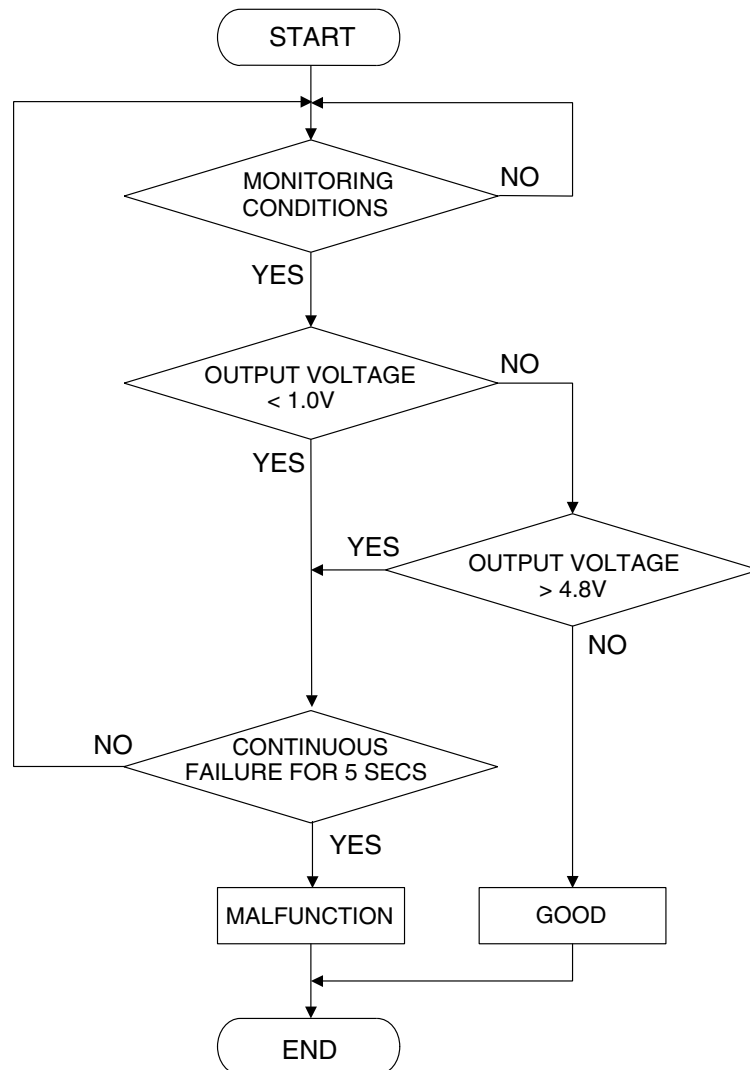

AC401447

DTC SET CONDITIONS

Check Conditions

- 2 seconds or more have passed since the starting sequence was completed.
- The fuel temperature is 36°C (97°F) or less.
- Remaining fuel level is 85% or less when the engine is started.

Judgment Criteria

- The fuel tank differential pressure sensor output voltage remains 4.8 volt or greater for 5 seconds.

OBD-II DRIVE CYCLE PATTERN

Refer to Diagnostic Function – OBD-II Drive Cycle – Procedure 1 – Evaporative Emission System Leak Monitor [P.13A-6](#).

TROUBLESHOOTING HINTS (THE MOST LIKELY CAUSES FOR THIS CODE TO BE SET ARE:)

- Malfunction of the fuel tank differential pressure sensor.
- Open or shorted fuel tank differential pressure sensor circuit.
- Malfunction of the PCM.

OVERVIEW OF TROUBLESHOOTING

- DTC P0453 can be set by a faulty fuel tank differential pressure sensor or related circuit, or PCM failure.
- To check for system blockage, do a performance test which uses a mechanical vacuum gauge and scan tool MB991958 set on the fuel tank differential pressure sensor (TANK PRS SNSR 73). The mechanical gauge reading is used to verify scan tool reading. A comparison of the mechanical gauge with the reading on scan tool MB991958 will locate a problem in the system.

DIAGNOSIS

Required Special Tools:

- MB991958: Scan Tool (MUT-III Sub Assembly)
 - MB991824: V.C.I.
 - MB991827: MUT-III USB Cable
 - MB991910: MUT-III Main Harness A
- MB991658: Test Harness Set
- MB991923: Power Plant ECU Check Harness

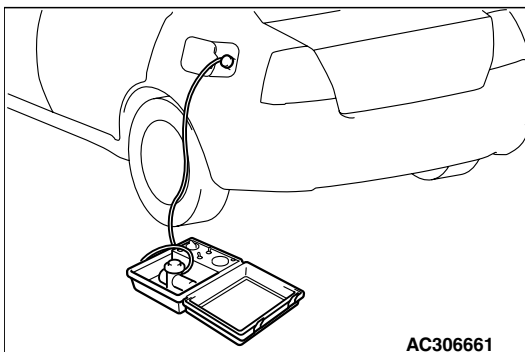
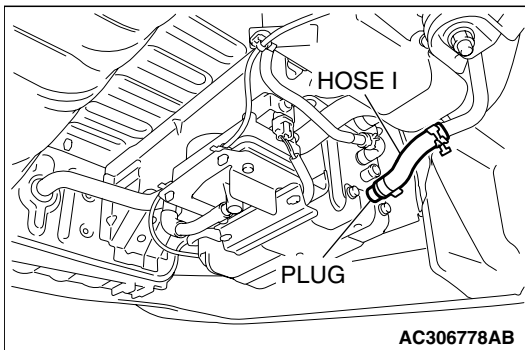
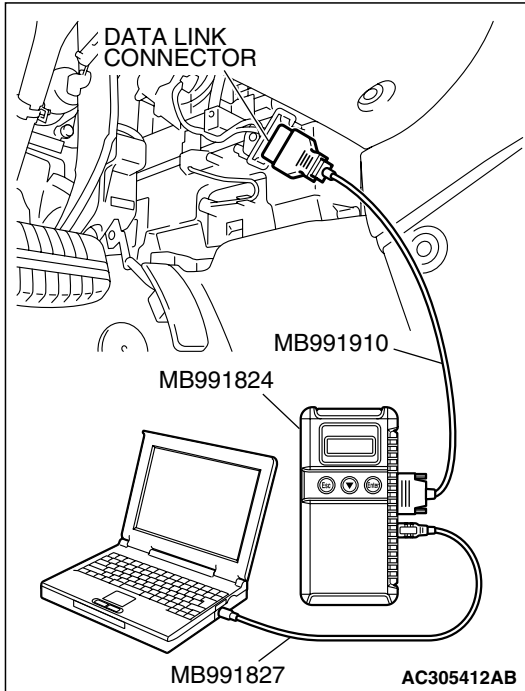

STEP 1. Using scan tool MB991958, check data list item 73: Fuel Tank Differential Pressure Sensor.

CAUTION

To prevent damage to scan tool MB991958, always turn the ignition switch to the "LOCK" (OFF) position before connecting or disconnecting scan tool MB991958.

(1) Connect scan tool MB991958 to the data link connector.

(2) Disconnect hose I from the evaporative emission canister, and plug the hose.

(3) Turn the ignition switch to the "ON" position.

(4) Remove the fuel cap.

(5) Set scan tool MB991958 to the data reading mode.

- Item 73, Fuel Tank Differential Pressure Sensor.
- The fuel tank pressure reading on the scan tool should be -1.5 to 1.5 kPa (-0.443 to 0.443 inHg).

(6) Connect the evaporative emission system pressure pump (Miller number 6872A) to the fuel tank filler tube by using fuel tank adapter (MLR-8382) and pressurize the fuel tank.

- The fuel tank pressure reading should increase.

(7) Turn the ignition switch to the "LOCK" (OFF) position. Then disconnect scan tool MB991958.

(8) Remove the evaporative emission system pressure pump (Miller number 6872A) and the fuel tank adapter (MLR-8382), and reinstall the fuel cap.

(9) Connect hose I to the evaporative emission canister.

Q: Is the fuel tank pressure between -1.5 and 1.5 kPa (-0.443 and 0.443 inHg)?

YES : It can be assumed that this malfunction is intermittent (Refer to GROUP 00, How to Use Troubleshooting/Inspection Service Points – How to Cope with Intermittent Malfunctions P.00-14). Go to Step 17.

NO : Go to Step 2.

STEP 2. Measure the sensor output voltage at PCM connector B-20 by using check harness special tool MB991923.

(1) Disconnect all the connectors from the PCM.

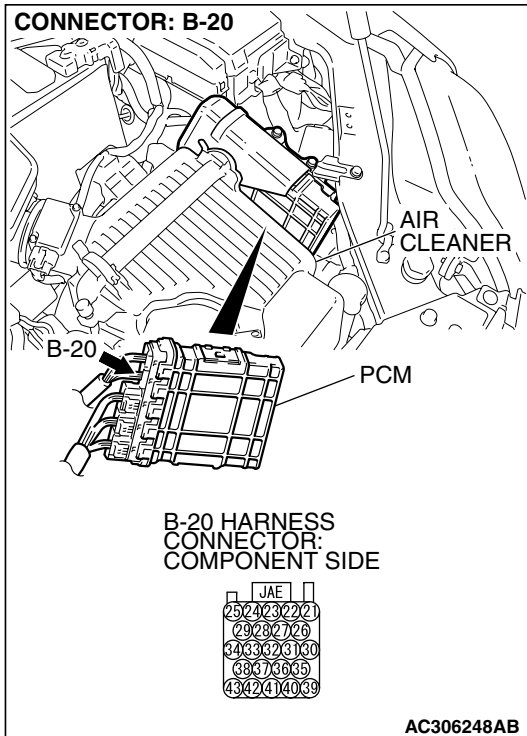

- (2) Connect special tool MB991923 (check harness) between the PCM and the body-side harness connector.
- (3) Turn the ignition switch to the "ON" position.
- (4) Remove the fuel cap.

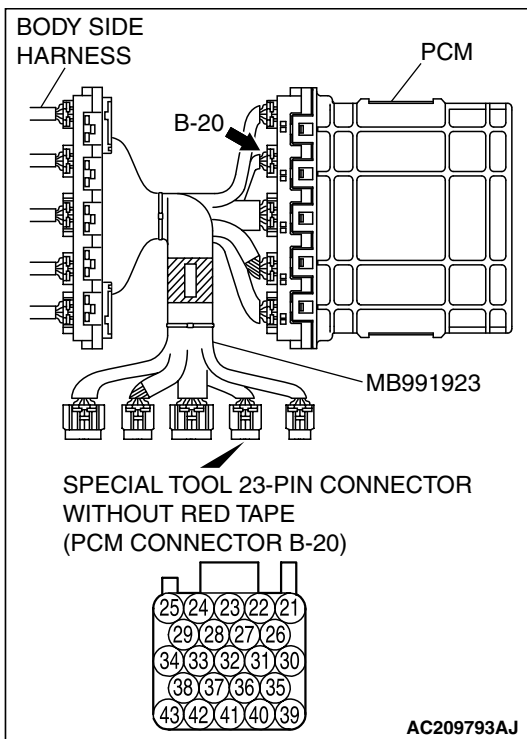

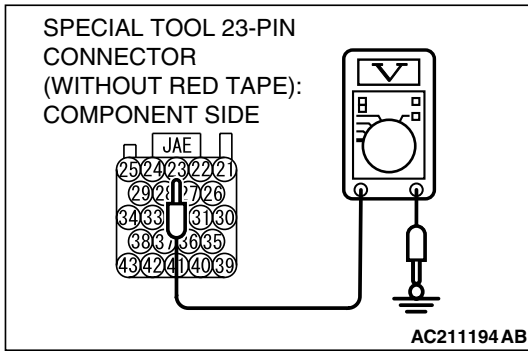

- (5) Measure the voltage between terminal 23 and ground.
 - The voltage should measure between 2.0 and 3.0 volts.
- (6) Install the fuel cap.
- (7) Turn the ignition switch to the "LOCK" (OFF) position.

Q: Is the measured voltage between 2.0 and 3.0 volts?

- YES :** Go to Step 16.
NO : Go to Step 3.

STEP 3. Measure the 5-volt reference signal at PCM connector B-20 by using check harness special tool MB991923.

- (1) Disconnect all the connectors from the PCM.

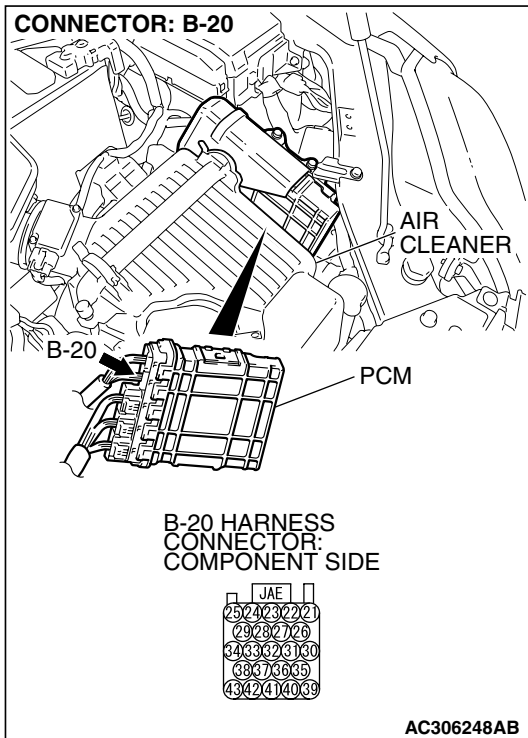

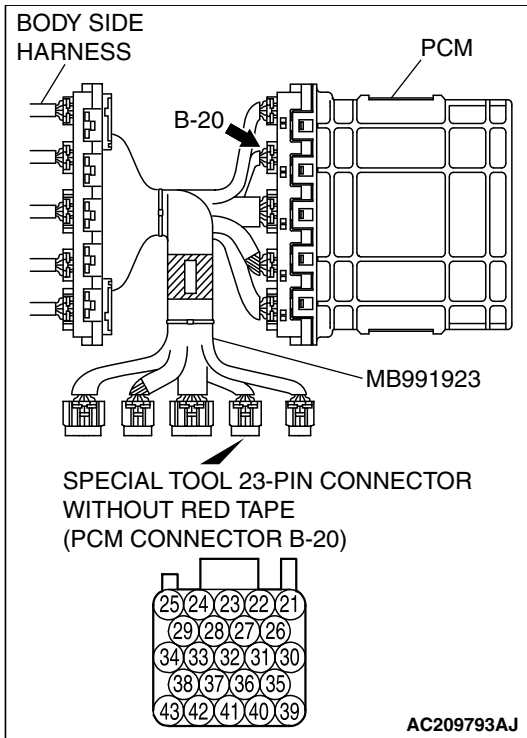

- (2) Connect special tool MB991923 (check harness) between the PCM and the body-side harness connector.
- (3) Turn the ignition switch to the "ON" position.

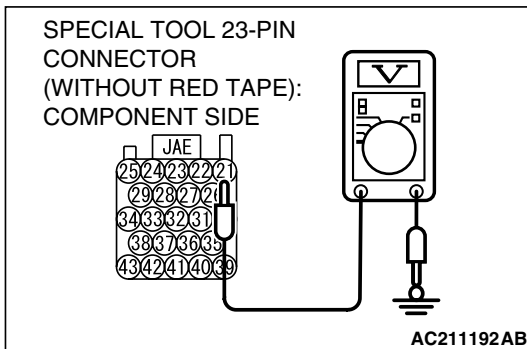

- (4) Measure the voltage between terminal 21 and ground.
 - The voltage should measure between 4.9 and 5.1 volts.
- (5) Turn the ignition switch to the "LOCK" (OFF) position.

Q: Is the measured voltage between 4.9 and 5.1 volts?

- YES** : Go to Step 5.
- NO** : Go to Step 4.

STEP 4. Check PCM connector B-20 for loose, corroded or damaged terminals, or terminals pushed back in the connector.

Q: Are the connector and terminals in good condition?

YES : Go to Step 16.

NO : Repair or replace the faulty components (Refer to GROUP 00E, Harness Connector Inspection [P.00E-2](#)). Then go to Step 17.

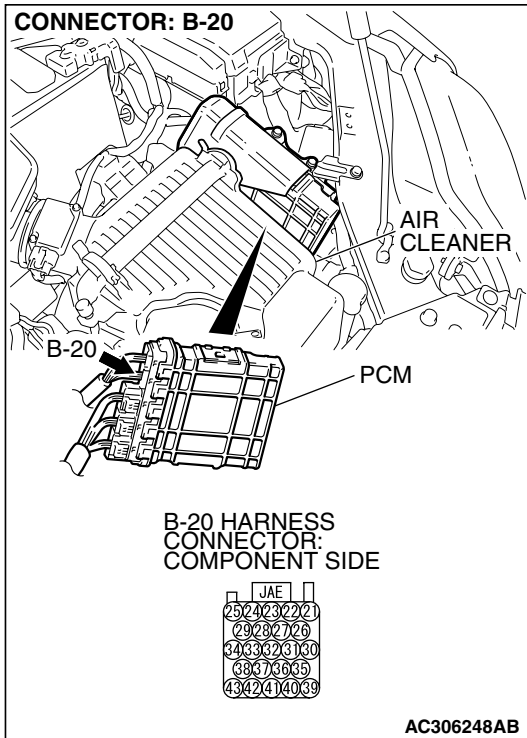

STEP 5. Measure the sensor output voltage at PCM connector B-20 by using check harness special tool MB991923.

(1) Disconnect all the connectors from the PCM.

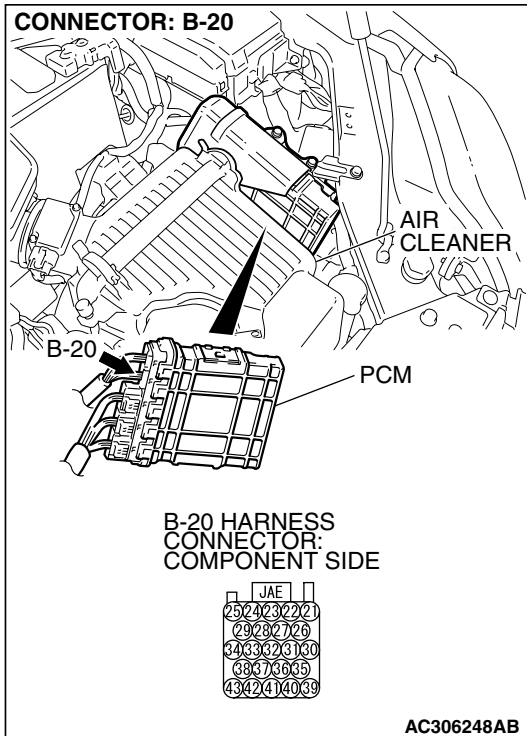

- (2) Connect special tool MB991923 (check harness) between the PCM and the body-side harness connector.
- (3) Turn the ignition switch to the "ON" position.
- (4) Remove the fuel cap.

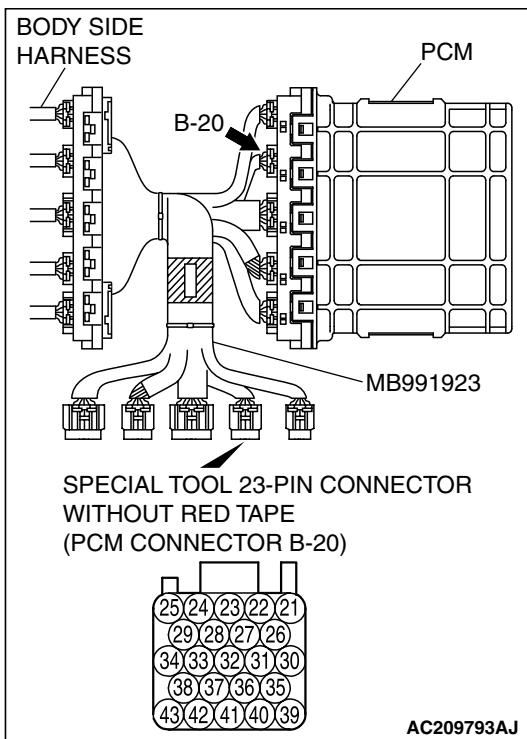

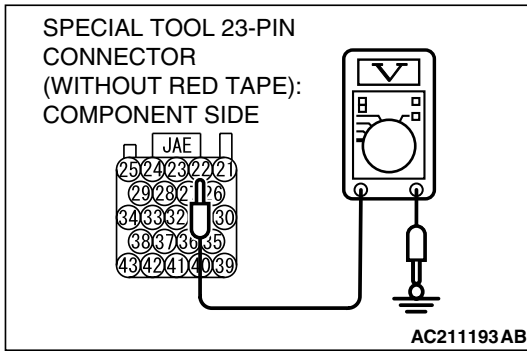

- (5) Measure the voltage between terminal 22 and ground.
 - The voltage should measure 0.5 volt or less.
- (6) Install the fuel cap.
- (7) Turn the ignition switch to the "LOCK" (OFF) position.

Q: Is the measured voltage 0.5 volt or less?

- YES** : Go to Step 6.
- NO** : Go to Step 9.

STEP 6. Measure the signal voltage at intermediate connector D-23.

- (1) Remove the rear seat cushion assembly (Refer to GROUP 52A, Rear Seat P.52A-29).
- (2) Remove the hole cover (RH).

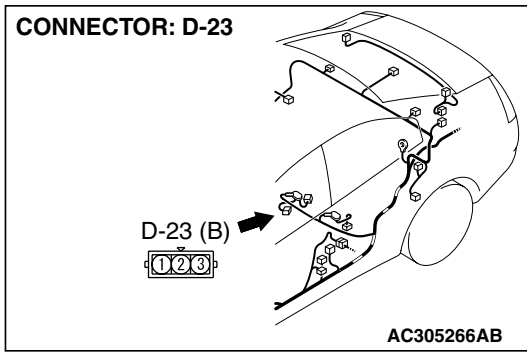
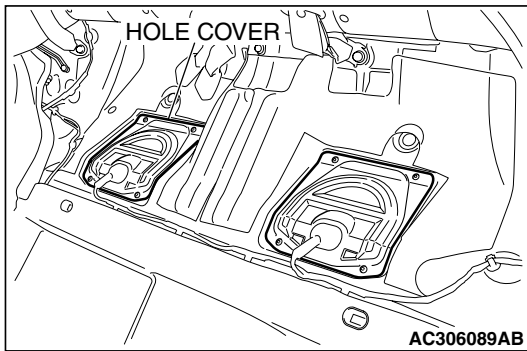

- (3) Disconnect fuel tank differential pressure sensor connector D-23.

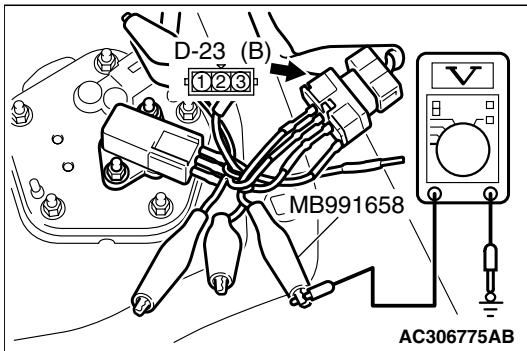

- (4) Use special tool MB991658 to connect terminals 1, 2 and 3 of the fuel tank differential pressure sensor connector D-23.
- (5) Turn the ignition switch to the "ON" position.
- (6) Remove the fuel cap.
- (7) Measure the voltage between connector D-23 terminal 1 and ground.
 - The voltage should measure between 2.0 and 3.0 volts.
- (8) Turn the ignition switch to the "LOCK" (OFF) position.

Q: Is the measured voltage between 2.0 and 3.0 volts?

- YES** : Go to Step 7.
- NO** : Go to Step 15.

STEP 7. Check PCM connector B-20, intermediate connector C-25 and fuel tank differential pressure sensor connector D-23 for loose, corroded or damaged terminals, or terminals pushed back in the connector.

Q: Are the connectors and terminals in good condition?

YES : Go to Step 8.

NO : Repair or replace the faulty components (Refer to GROUP 00E, Harness Connector Inspection [P.00E-2](#)). Then go to Step 17.

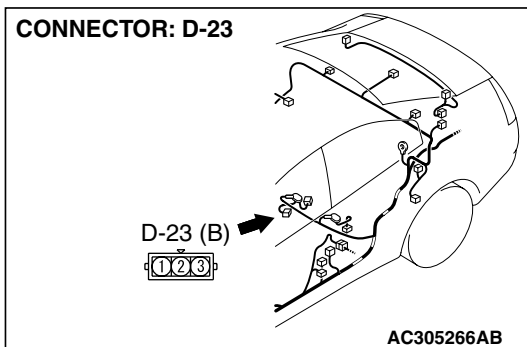
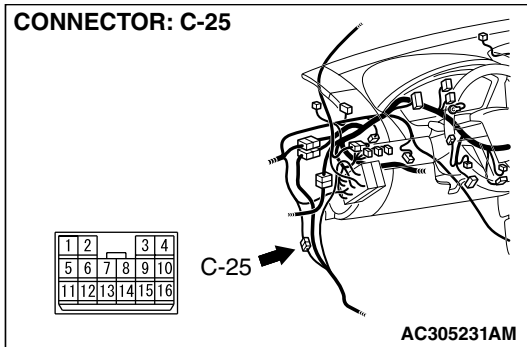
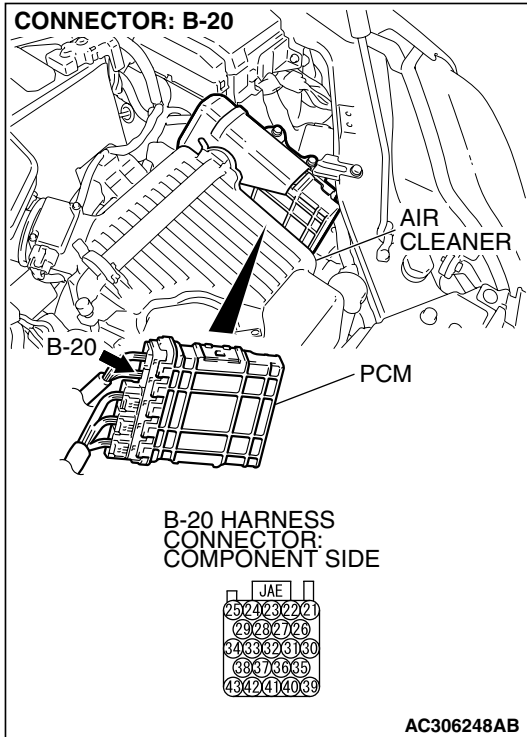

STEP 8. Check the harness wire between PCM connector B-20 terminal 23 and fuel tank differential pressure sensor connector D-23 terminal 1 for damage.

Q: Is the harness wire in good condition?

YES : This malfunction is intermittent (Refer to GROUP 00, How to Use Troubleshooting/Inspection Service Points – How to Cope with Intermittent Malfunctions [P.00-14](#)). Go to Step 17.

NO : Repair the damaged harness wire. Then go to Step 17.

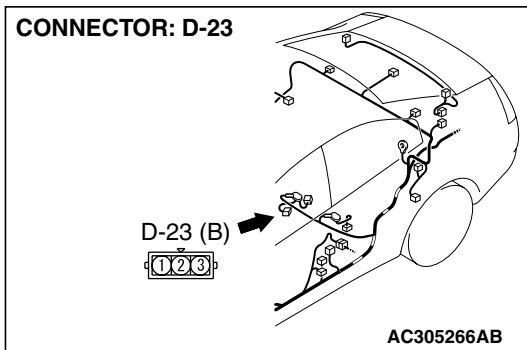
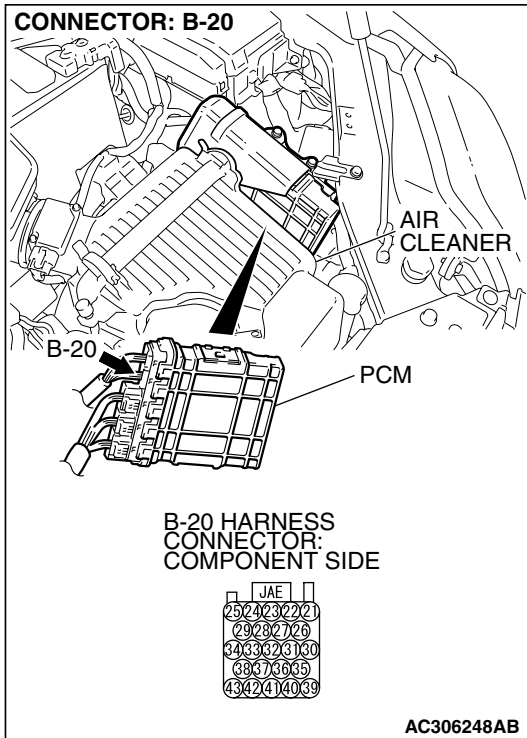

STEP 9. Measure the 5-volt reference signal at fuel tank differential pressure sensor connector D-23.

- (1) Remove the rear seat cushion assembly (Refer to GROUP 52A, Rear Seat P.52A-29).
- (2) Remove the hole cover (RH).

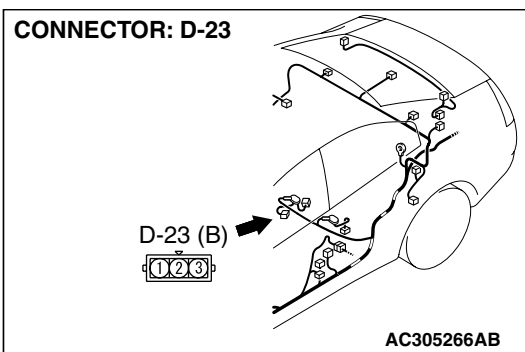
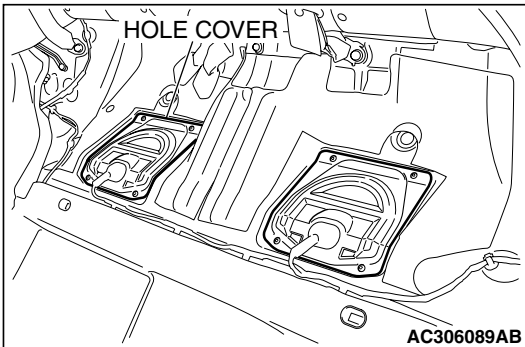

- (3) Disconnect fuel tank differential pressure sensor connector D-23.

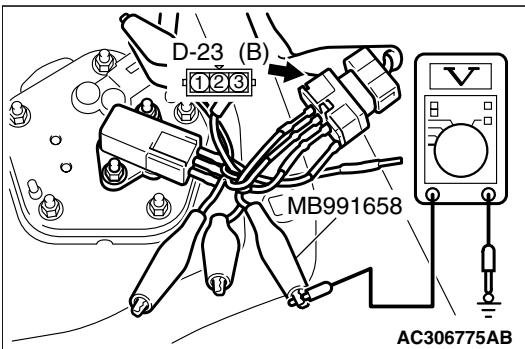

- (4) Use special tool MB991658 to connect terminals 1,2 and 3 of the fuel tank differential pressure sensor connector D-23.
- (5) Turn the ignition switch to the "ON" position.
- (6) Measure the voltage between terminal 3 and ground.
 - The voltage should measure between 4.9 and 5.1 volts.
- (7) Turn the ignition switch to the "LOCK" (OFF) position.

Q: Is the measured voltage between 4.9 and 5.1 volts?

- YES :** Go to Step 12.
NO : Go to Step 10.

STEP 10. Check PCM connector B-20, intermediate connector C-25 and fuel tank differential pressure sensor connector D-23 for loose, corroded or damaged terminals, or terminals pushed back in the connector.

Q: Are the connectors and terminals in good condition?

YES : Go to Step 11.

NO : Repair or replace the faulty components (Refer to GROUP 00E, Harness Connector Inspection [P.00E-2](#)). Then go to Step 17.

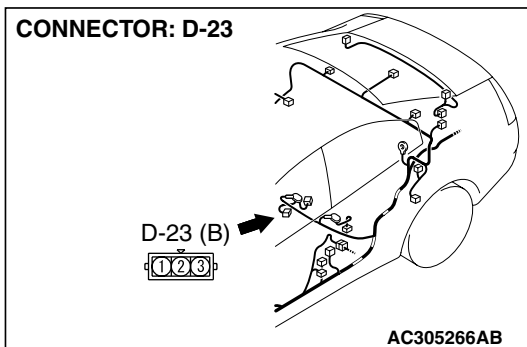
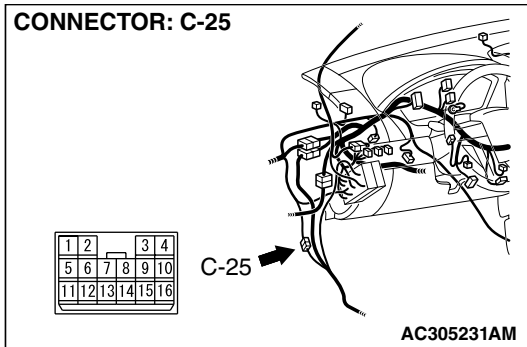
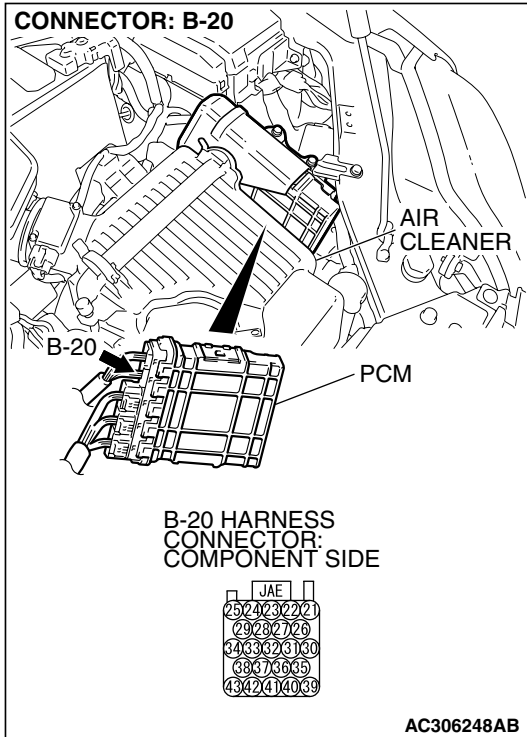

STEP 11. Check the harness wire between PCM connector B-20 terminal 21 and fuel tank differential pressure sensor connector D-23 terminal 3 for damage.

Q: Are the harness wires in good condition?

YES : It can be assumed that this malfunction is intermittent (Refer to GROUP 00, How to Use Troubleshooting/Inspection Service Points – How to Cope with Intermittent Malfunctions P.00-14). Go to Step 17.

NO : Repair the damaged harness wires. Then go to Step 17.

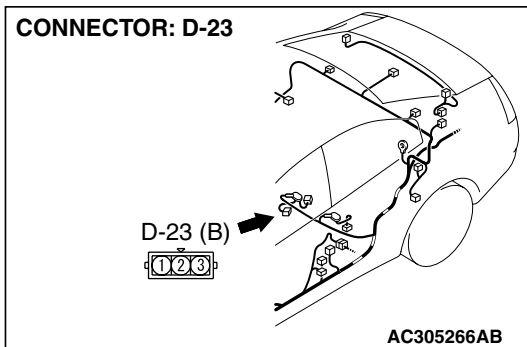
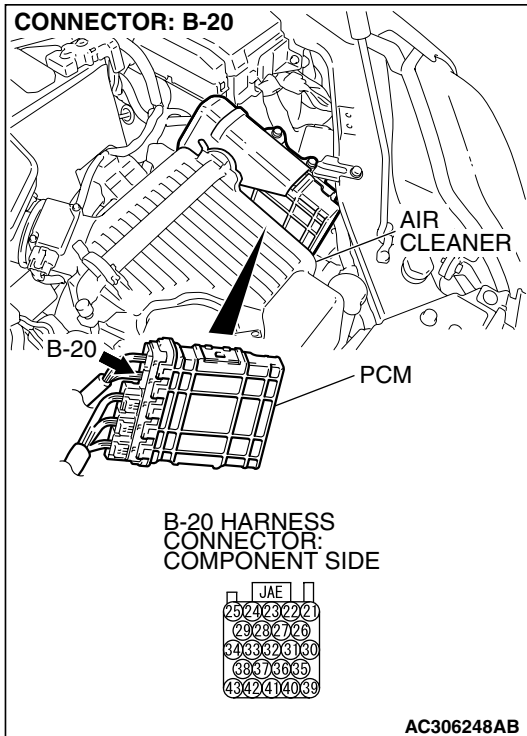

STEP 12. Measure the fuel tank differential pressure sensor return voltage at fuel tank differential pressure sensor connector D-23.

- (1) Remove the rear seat cushion assembly (Refer to GROUP 52A, Rear Seat P.52A-29).
- (2) Remove the hole cover (RH).

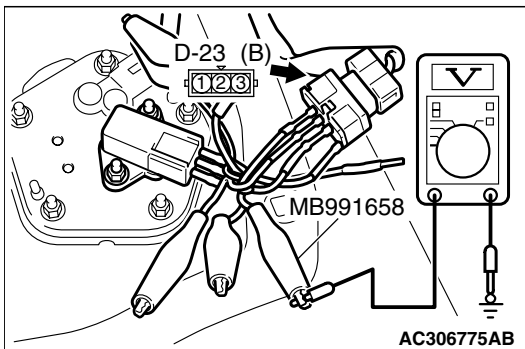
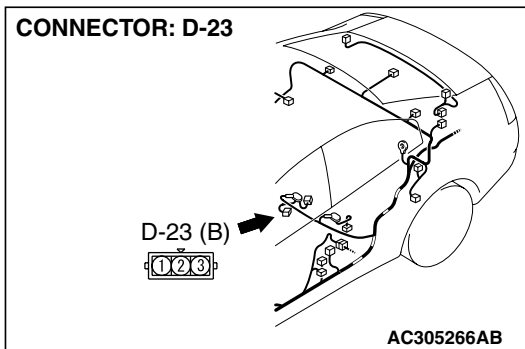
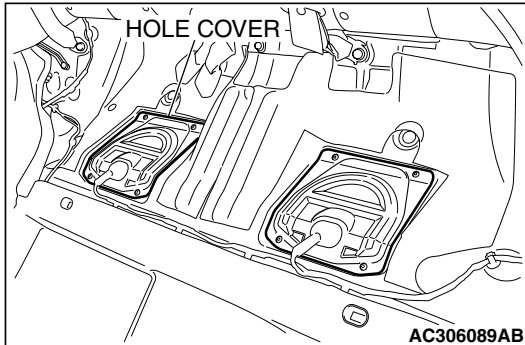

- (3) Disconnect fuel tank differential pressure sensor connector D-23.

- (4) Use special tool MB991658 to connect terminals 1,2 and 3 of the fuel tank differential pressure sensor connector D-23.
- (5) Turn the ignition switch to the "ON" position.
- (6) Measure the voltage between terminal 2 and ground.
 - The voltage should measure 0.5 volt or less.
- (7) Turn the ignition switch to the "LOCK" (OFF) position.

Q: Is the measured voltage 0.5 volt or less?

- YES** : Go to Step 13.
NO : Go to Step 17.

STEP 13. Check PCM connector B-20, intermediate connector C-25 and fuel tank differential pressure sensor connector D-23 for loose, corroded or damaged terminals, or terminals pushed back in the connector.

Q: Are the connectors and terminals in good condition?

YES : Go to Step 14.

NO : Repair or replace the faulty components (Refer to GROUP 00E, Harness Connector Inspection [P.00E-2](#)). Then go to Step 17.

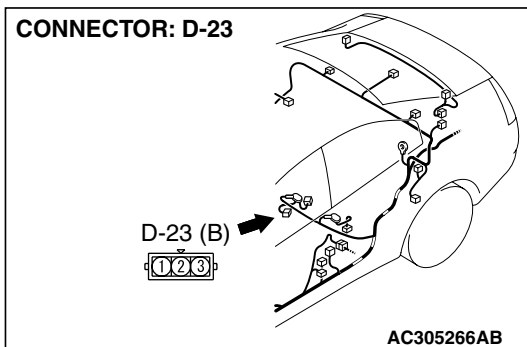
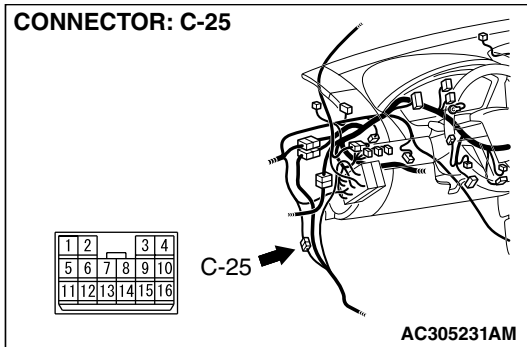
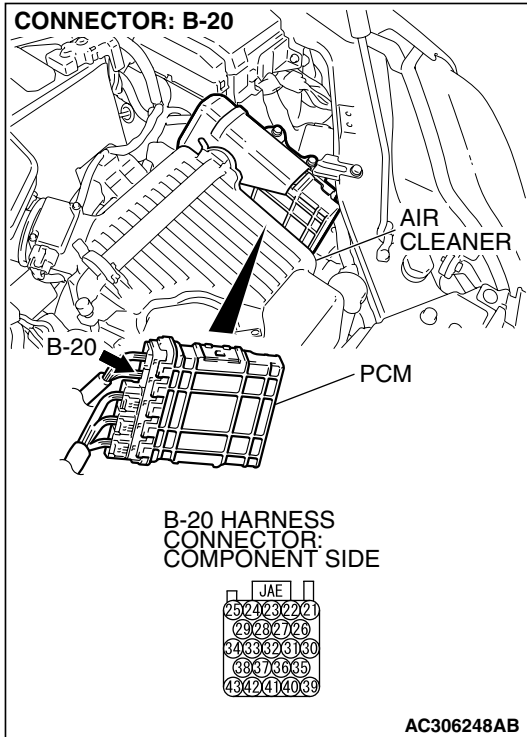

STEP 14. Check the harness wires between PCM connector B-20 terminal 22 and fuel tank differential pressure sensor connector D-23 terminal 2 for damage.
Q: Are the harness wires in good condition?

YES : Go to Step 17.

NO : Repair the damaged harness wires. Then go to Step 17.

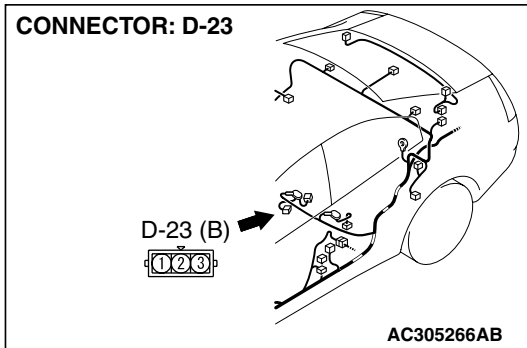
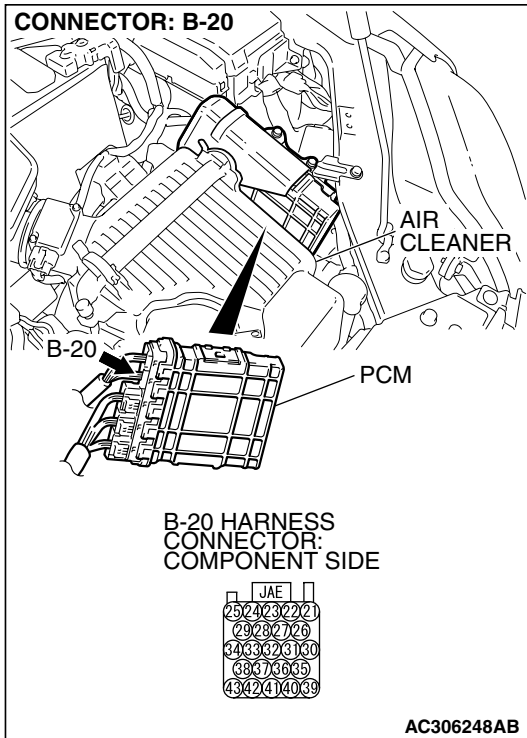

STEP 15. Check fuel tank differential pressure sensor connector D-23 for loose, corroded or damaged terminals, or terminals pushed back in the connector.

Q: Is the connectors and terminals in good condition?

YES : Replace the fuel tank differential pressure sensor. Then go to Step 17.

NO : Repair or replace the faulty components (Refer to GROUP 00E, Harness Connector Inspection [P.00E-2](#)). Then go to Step 17.

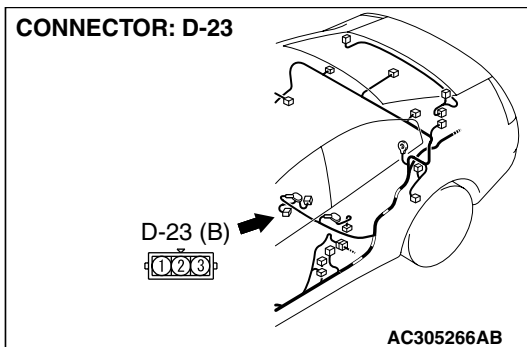

STEP 16. Using scan tool MB991958, check data list item 73: Fuel Tank Differential Pressure Sensor.

CAUTION

To prevent damage to scan tool MB991958, always turn the ignition switch to the "LOCK" (OFF) position before connecting or disconnecting scan tool MB991958.

(1) Connect scan tool MB991958 to the data link connector.

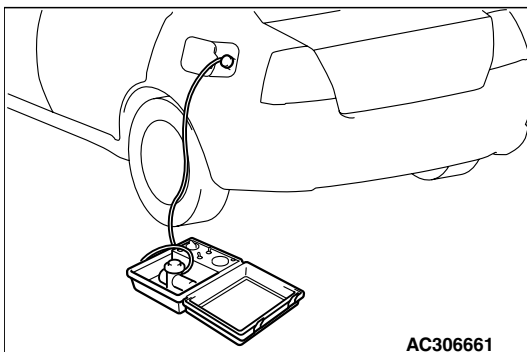
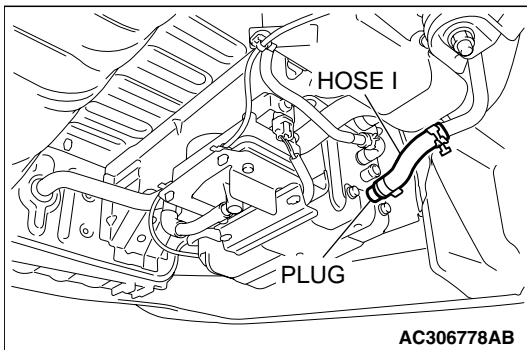
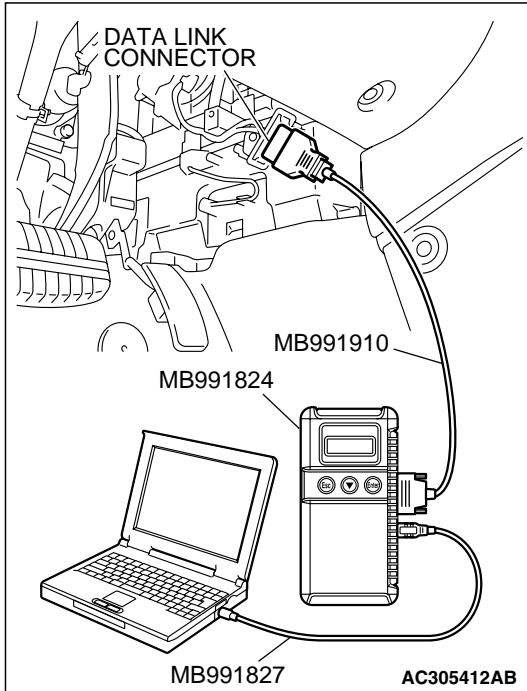

(2) Disconnect hose I from the evaporative emission canister, and plug the hose.

(3) Turn the ignition switch to the "ON" position.

(4) Remove the fuel cap.

(5) Set scan tool MB991958 to the data reading mode.

- Item 73, Fuel Tank Differential Pressure Sensor.
- The fuel tank pressure reading on the scan tool should be -1.5 to 1.5 kPa (-0.443 to 0.443 inHg).

(6) Connect the evaporative emission system pressure pump (Miller number 6872A) to the fuel tank filler tube by using fuel tank adapter (MLR-8382) and pressurize the fuel tank.

- The fuel tank pressure reading should increase.

(7) Turn the ignition switch to the "LOCK" (OFF) position. Then disconnect scan tool MB991958.

(8) Remove the evaporative emission system pressure pump (Miller number 6872A) and the fuel tank adapter (MLR-8382), and reinstall the fuel cap.

(9) Connect hose I to the evaporative emission canister.

Q: Is the fuel tank pressure between -1.5 and 1.5 kPa (-0.443 and 0.443 inHg)?

YES : It can be assumed that this malfunction is intermittent (Refer to GROUP 00, How to Use Troubleshooting/Inspection Service Points – How to Cope with Intermittent Malfunctions P.00-14). Go to Step 17.

NO : Replace the PCM (Refer to P.13A-1140). Then go to Step 17 .

STEP 17. Perform the OBD-II drive cycle.

- (1) Carry out a test drive with the drive cycle pattern (Refer to Diagnostic Function – OBD-II Drive Cycle – Procedure 1 – Evaporative Emission System Leak Monitor P.13A-6).
- (2) Read the diagnostic trouble code (DTC).

Q: Is DTC P0453 set?

YES : Repeat the troubleshooting from Step 2.

NO : The procedure is complete.

DTC P0455: Evaporative Emission System Leak Detected (Gross Leak)

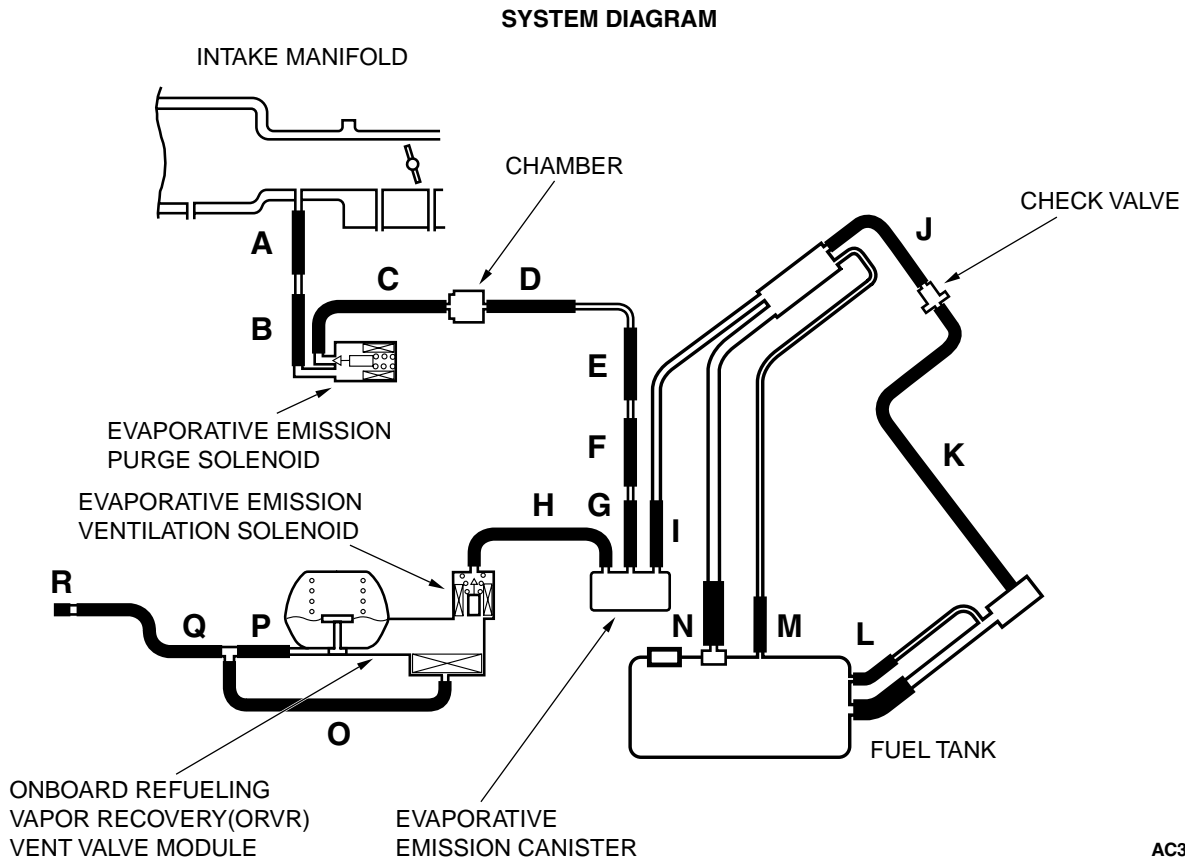

AC306277 AB

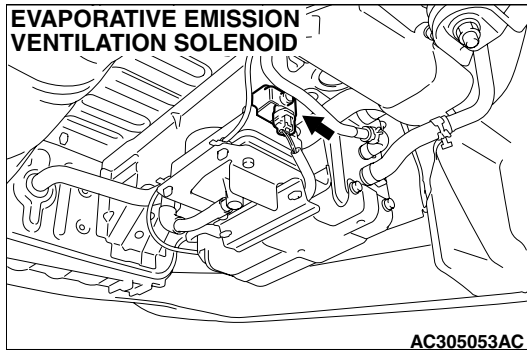
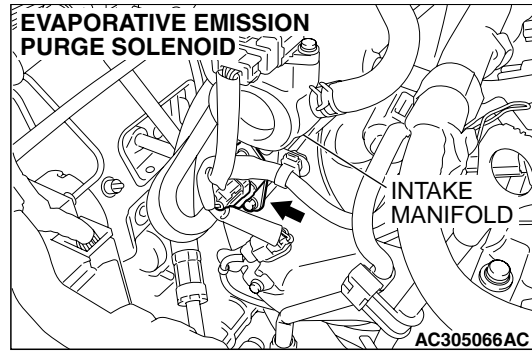
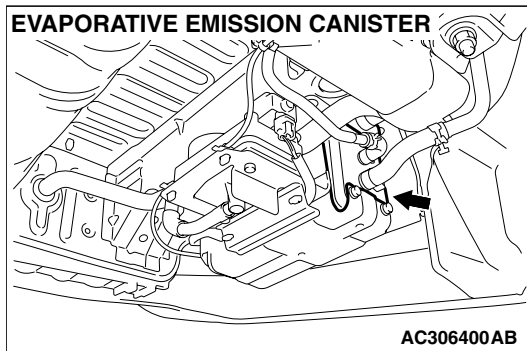

TECHNICAL DESCRIPTION

- The fuel tank may be under a slight pressure or vacuum depending on the state of the Evaporative Emission (EVAP) System. The PCM monitors and responds to these pressure/vacuum changes. If the pressure/vacuum varies from the specified range, the PCM will set DTC P0455.
- The PCM energizes the evaporative emission ventilation solenoid to shut off the evaporative emission canister outlet port.
- The evaporative emission purge solenoid is activated to apply engine manifold vacuum to the EVAP system.
- When the fuel system develops a vacuum of 2 kPa (0.29 psi), the evaporative emission purge solenoid is turned "off" and the fuel system vacuum is maintained at 2 kPa (0.29 psi).
- The PCM determines whether there is a leak or clog in the fuel system by measuring the change in vacuum inside the fuel tank.
- The test is stopped when fuel vapor pressure is determined to be too high.

DESCRIPTIONS OF MONITOR METHODS

- Depressurizing EVAP system by intake manifold negative pressure is impossible within specified period.

MONITOR EXECUTION

- Once per driving cycle.

MONITOR EXECUTION CONDITIONS (OTHER MONITOR AND SENSOR)

Other Monitor (There is no temporary DTC stored in memory for the item monitored below)

- Evaporative emission purge solenoid monitor
- Evaporative emission purge system monitor
- Fuel tank differential pressure sensor monitor
- Evaporative emission ventilation solenoid monitor
- Fuel level sensor monitor
- Fuel temperature sensor monitor

Sensor (The sensors below are determined to be normal)

- Mass airflow sensor
- Barometric pressure sensor
- Intake air temperature sensor
- Engine coolant temperature sensor

LOGIC FLOW CHARTS (Monitor Sequence)

0.04in, 0.02in GROSS LEAK MONITOR

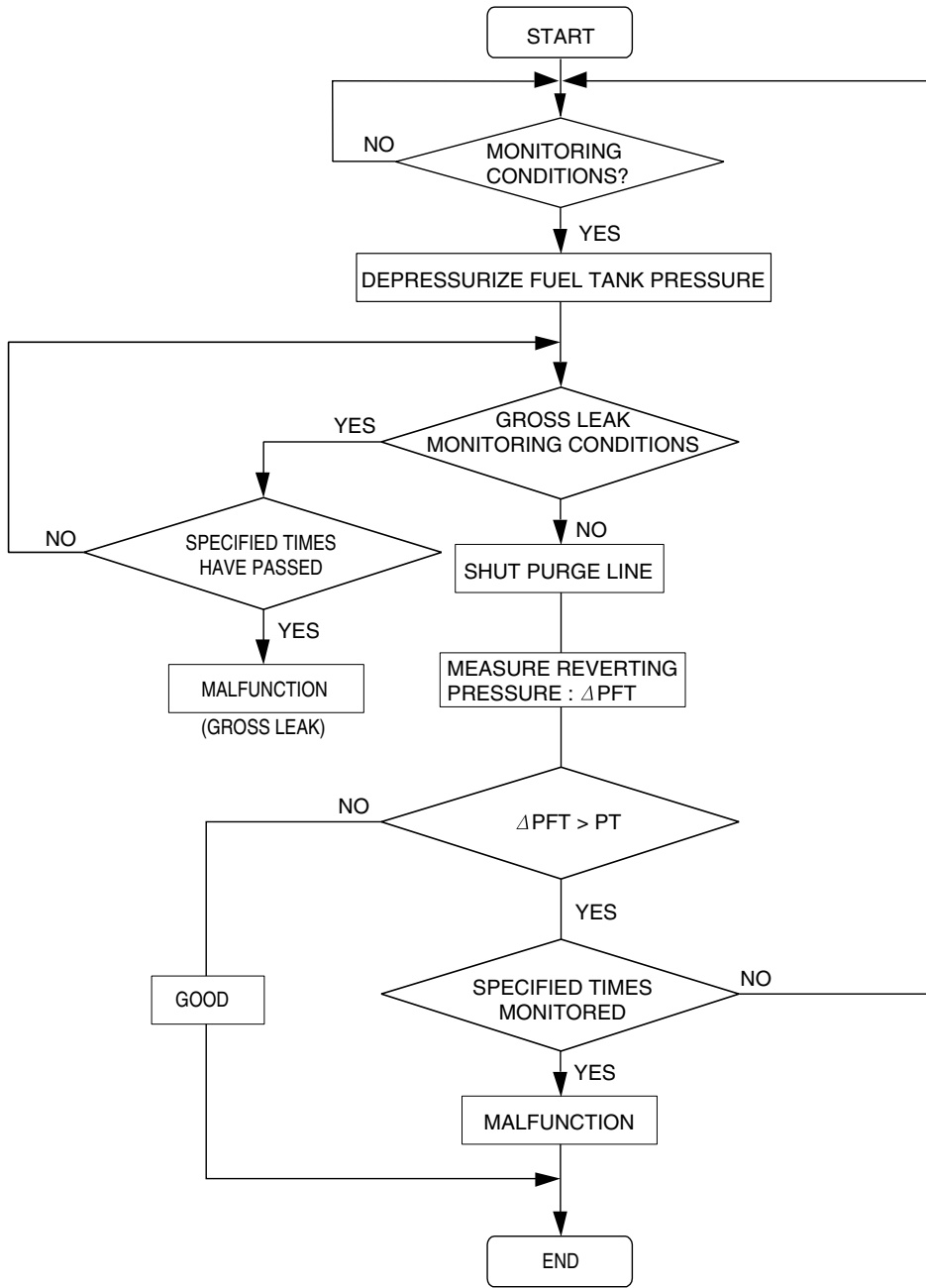

AC306649

DTC SET CONDITIONS

Check Conditions A: At Start up

- Intake air temperature is 36°C (97°F) or less upon engine start up.
- The engine coolant temperature is 36°C (97°F) or less upon engine start up.

Check Conditions B: For Test to Run

- The engine coolant temperature is 60°C (140°F) or greater and the fuel tank is 15 – 40 percent full.
- The engine coolant temperature is 20°C (68°F) or greater and the fuel tank is 40 – 85 percent full.
- The engine speed is greater than or equal to 1,600 r/min.
- Barometric pressure is greater than 76 kPa (11 psi).
- Volumetric efficiency is between 20 and 70 percent.
- The fuel tank temperature is 36°C (97°F) or less.
- The fuel tank differential pressure sensor output voltage is 1 – 4 volts.

Check Conditions C: For Test to Stop

- The intake air temperature is greater than 5°C (41°F).
- When the evaporative emission purge solenoid and evaporative emission ventilation solenoid are closed, the pressure in the fuel tank rises to 451 Pa (0.065 psi) or less and the amount of remaining fuel is 15 – 40 percent of capacity upon engine start-up.

- When the evaporative emission purge solenoid and evaporative emission ventilation solenoid are closed, the pressure in the fuel tank rises to 324 Pa (0.047 psi) or less and the amount of remaining fuel is 40 – 85 percent of capacity upon engine start-up.
- 10 seconds have elapsed from the start of the previous monitoring.
- Monitoring time: 150 seconds.

Judgment Criteria

- The fuel tank internal pressure is 2 kPa (0.29 psi) or more after the evaporative emission purge solenoid valve has been driven when the fuel tank and vapor line were closed.

OBD-II DRIVE CYCLE PATTERN

Refer to Diagnostic Function – OBD-II Drive Cycle – Procedure 1 – Evaporative Emission System Leak Monitor [P.13A-6](#).

TROUBLESHOOTING HINTS (THE MOST LIKELY CAUSES FOR THIS CODE TO BE SET ARE:)

- Loose fuel cap.
- Fuel cap relief pressure is incorrect.
- Fuel overflow limiter valve failed.
- Purge line or vapor line is clogged.
- Fuel tank, purge line or vapor line seal failed.
- Evaporative emission purge solenoid valve failed.
- Evaporative emission ventilation solenoid valve failed.
- Fuel tank differential pressure sensor failed.
- Evaporative emission canister seal is faulty.
- Evaporative emission canister is clogged.

DIAGNOSIS**Required Special Tools:**

- MB991958: Scan Tool (MUT-III Sub Assembly)
 - MB991824: V.C.I.
 - MB991827: MUT-III USB Cable
 - MB991910: MUT-III Main Harness A

STEP 1. Using scan tool MB991958, check the evaporative emission system monitor test.**⚠ CAUTION**

- To prevent damage to scan tool MB991958, always turn the ignition switch to the "LOCK" (OFF) position before connecting or disconnecting scan tool MB991958.
- During this test, the PCM will automatically increase the engine speed to 1,600 r/min or greater. Check that the transaxle is set to the "P" position.

- (1) Connect scan tool MB991958 to the data link connector.
- (2) Turn the ignition switch to the "ON" position.
- (3) Erase the DTCs using scan tool MB991958.
- (4) Check that the fuel cap is securely closed (Tighten until three clicks are heard).
- (5) Start the engine.
- (6) Select "System Test."
- (7) Select "Evap Leak Mon."
- (8) During this test, keep the accelerator pedal at the idle position.
- (9) Keep the engine speed and engine load within the specified range. When the monitor test starts, the "In Progress" item on scan tool MB991958 will change from "NO" to "YES."
- (10) Turn the ignition switch to the "LOCK" (OFF) position, and disconnect scan tool MB991958.

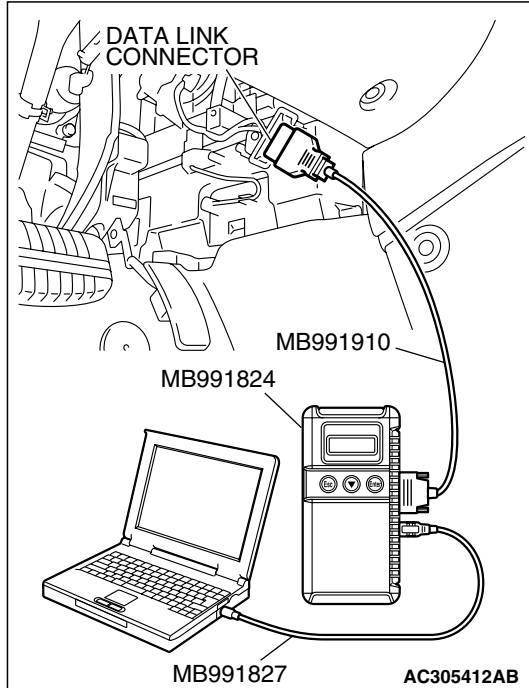
**Q: Is "Evap Leak Mon. Completed. Test Failed and DTCs Set" displayed on scan tool MB991958?**

YES : A malfunction has been detected during the monitor test. Refer to the Diagnostic Trouble Code Chart and diagnose any other DTCs that are set [P.13A-33](#). If no other DTC's have been set, go to Step 2.

NO <"Evap Leak Mon. Completed. Test Passed" is displayed on scan tool MB991958.> : The evaporative emission system is working properly at this time. Explain to the customer that an improperly tightened fuel cap can cause the MIL to illuminate. Return the vehicle to the customer.

NO <"Evap Leak Mon. Discontinued. Retest again from the first" is displayed on scan tool MB991958.> : The EVAP monitor has been interrupted during the test. Turn the ignition switch to the "LOCK" (OFF) position once, and repeat the monitoring from Step 1.

STEP 2. Using scan tool MB991958, check actuator test item 08: Evaporative Emission Purge Solenoid Valve.

⚠ CAUTION

To prevent damage to scan tool MB991958, always turn the ignition switch to the "LOCK" (OFF) position before connecting or disconnecting scan tool MB991958.

(1) Connect scan tool MB991958 to the data link connector.

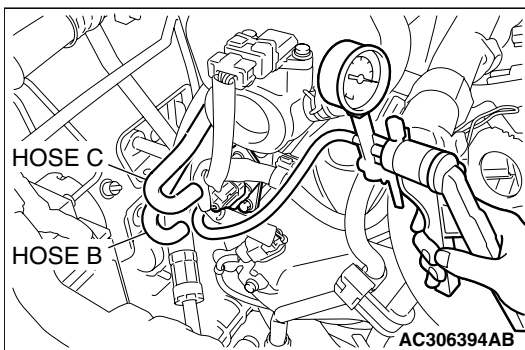
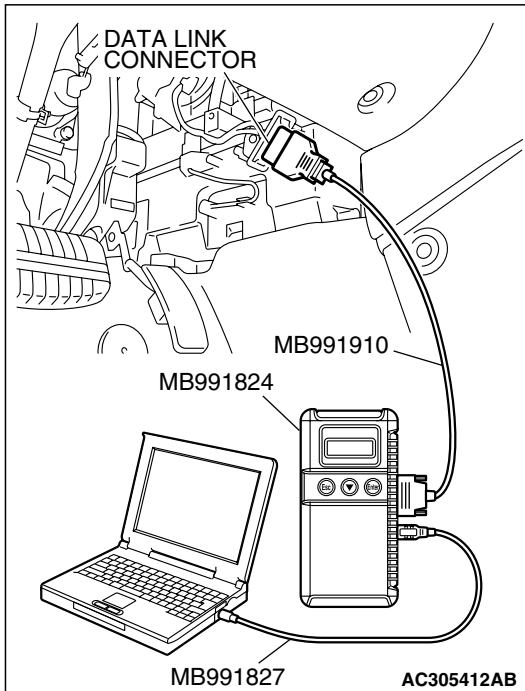

(2) Disconnect hoses B and C from the evaporative emission purge solenoid valve side, and connect the hand vacuum pump to the evaporative emission purge solenoid valve instead of hose C.

(3) Turn the ignition switch to the "ON" position.

(4) Set scan tool MB991958 to actuator test mode.

- Item 08: Evaporative Emission Purge Solenoid Valve.
- When the evaporative emission purge solenoid valve is operated, apply a pressure on the hand vacuum pump and confirm that air is blown from the other side nipple.

(5) Turn the ignition switch to the "LOCK" (OFF) position.

(6) Disconnect the hand vacuum pump, and connect hoses A and B to the evaporative emission purge solenoid valve.

Q: Is the solenoid valve in good condition?

YES : Go to Step 3.

NO : Replace the evaporative emission purge solenoid valve. Then go to Step 19.

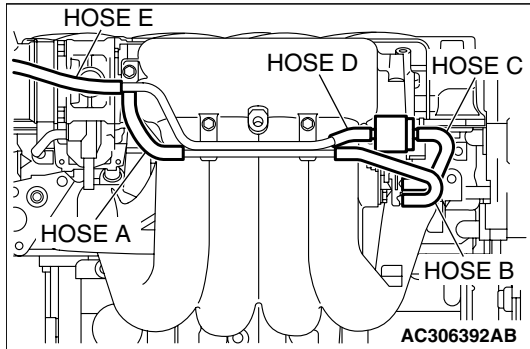

STEP 3. Check for leaks and clogging in evaporative emission hoses A through E.

Use a hand vacuum pump to test each hose from hose A to hose E.

Q: Are the hoses in good condition?

YES : Go to Step 4.

NO : Replace the damaged hose. Then go to Step 19.

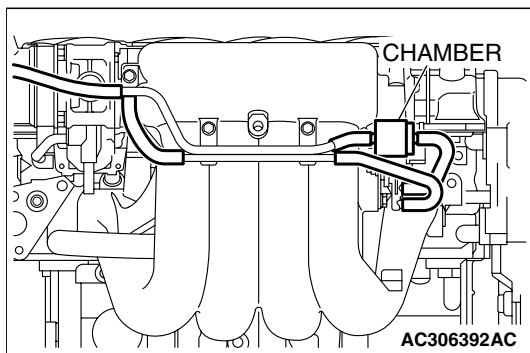

STEP 4. Check for leaks and clogging in the chamber.

(1) When you blow the chamber, it should pass less air.

(2) When you blow the chamber, on air should leak from the chamber body.

Q: Is the chamber in good condition?

YES : Go to Step 5.

NO : Replace the chamber. Then go to Step 19.

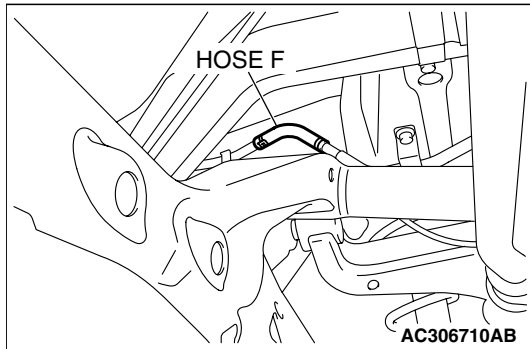

STEP 5. Check for leaks and clogging in evaporative emission hoses F through H.

Perform a vacuum test using a hand vacuum pump on hoses F through H.

Q: Are the hoses in good condition?

YES : Go to Step 6.

NO : Replace the damaged hose. Then go to Step 19.

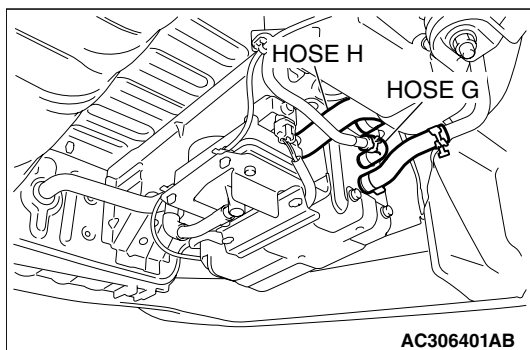

STEP 6. Using scan tool MB991958, check data list item 29: Evaporative emission ventilation solenoid.

CAUTION

To prevent damage to scan tool MB991958, always turn the ignition switch to the "LOCK" (OFF) position before connecting or disconnecting scan tool MB991958.

- (1) Connect scan tool MB991958 to the data link connector.
- (2) Remove the fuel tank filler tube protector (Refer to GROUP 13C, Fuel Tank P.13C-10).

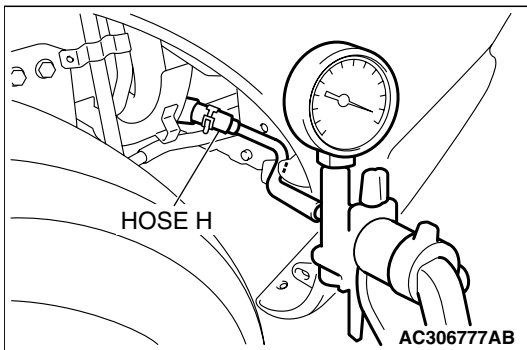
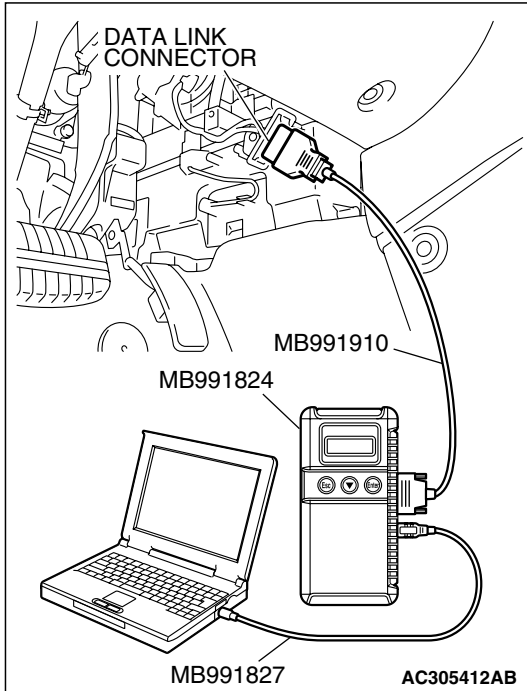

- (3) Disconnect hose H from evaporative emission canister and connect hand vacuum pump to hose H.
- (4) Turn the ignition switch to the "ON" position.
- (5) Set scan tool MB991958 to actuator test mode.
 - Item 29: Evaporative Emission Ventilation Solenoid.
 - While the evaporative emission ventilation solenoid is energized, operate the hand vacuum pump and confirm that the solenoid holds vacuum.
- (6) Turn the ignition switch to the "LOCK" (OFF) position, and disconnect scan tool MB991958.
- (7) Disconnect the hand vacuum pump, and connect hose H to the evaporative emission canister.
- (8) Reinstall the fuel tank filler tube protector (Refer to GROUP 13C, Fuel Tank P.13C-10).

Q: Did the evaporative emission ventilation solenoid hold vacuum?

YES : Go to Step 7.

NO : Replace the evaporative emission ventilation solenoid (Refer to GROUP 17, Evaporative emission canister and fuel tank pressure relief valve removal and installation P.17-95). Then go to Step 19.

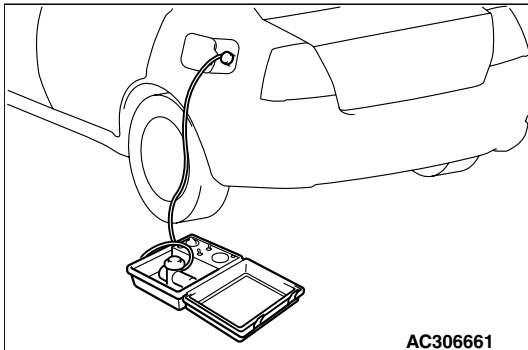
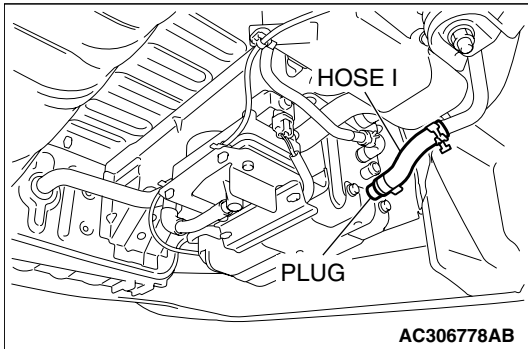

STEP 7. Pressure test the evaporative emission system lines from hoses I to N.

- (1) Disconnect hose I from the evaporative emission canister, and plug hose I securely.
- (2) Confirm that the evaporative emission system pressure pump (Miller number 6872A) is operating properly. Perform the self-test as described in the pump manufacturer's instructions.
- (3) Remove the fuel cap.

- (4) Connect the evaporative emission system pressure pump (Miller number 6872A) to the fuel tank filler tube by using fuel tank adapter (MLR-8382).
- (5) Pressure test the system to determine whether any leaks are present.

NOTE: The "Pressure test" in this procedure refers to the I/M240 Simulation Test. The eight steps of this test are described in the manufacturer's instructions for the evaporative emission system pressure pump, Miller number 6872A.

- (6) Remove the evaporative emission system pressure pump (Miller number 6872A) and the fuel tank adapter (MLR-8382), and reinstall the fuel cap.
- (7) Connect hose I to the evaporative emission canister.

Q: Is the evaporative emission system line free of leaks?

YES : Go to Step 13.

NO : Go to Step 8.

STEP 8. Check for leaks in evaporative emission hoses I through K.

- (1) Remove the fuel tank filler tube protector (Refer to GROUP 13C, Fuel Tank P.13C-10).
- (2) Use a hand vacuum pump to test each hose from hose I to hose K.

Q: Do the hoses hold vacuum?

YES : Go to Step 9.

NO : Replace any damaged hose. Then go to Step 19.

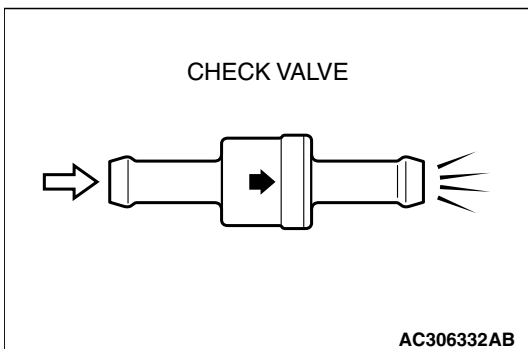
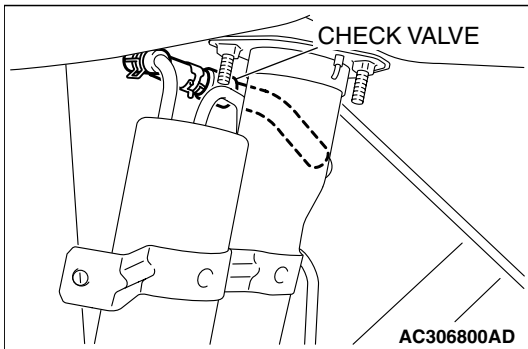
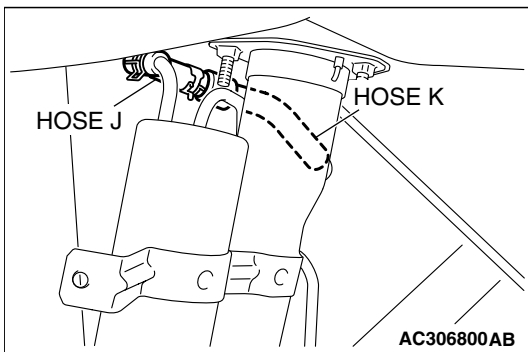
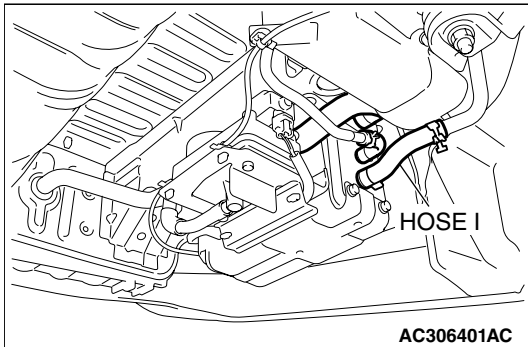

STEP 9. Test check valve.

- (1) Check valve is a one-way check valve.

- (2) Check valve should allow air to flow in only one direction.

Q: Does check valve allow air to pass in one direction only?

YES : Go to Step 10.

NO : Replace check valve, and reinstall the fuel tank filler tube protector (Refer to GROUP 13C, Fuel Tank P.13C-10). Then go to Step 19.

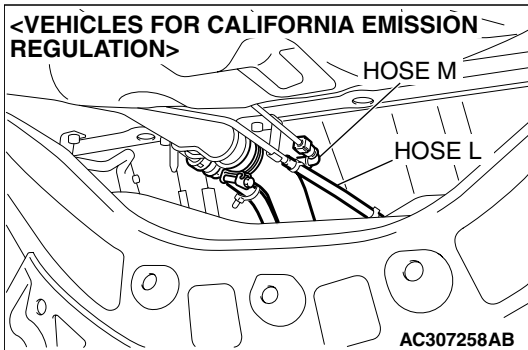
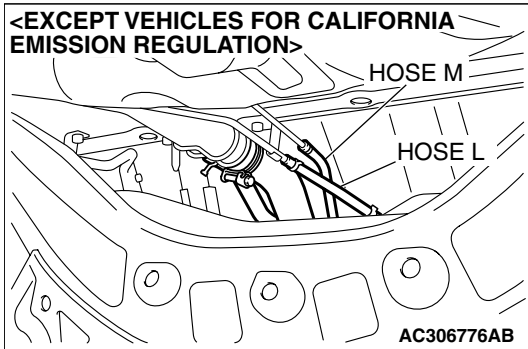

STEP 10. Check for leaks in evaporative emission hoses L and M.

Use a hand vacuum pump to test each hose L and M.

Q: Do the hoses hold vacuum?

YES : Go to Step 11.

NO : Replace any damaged hose. Then go to Step 19.

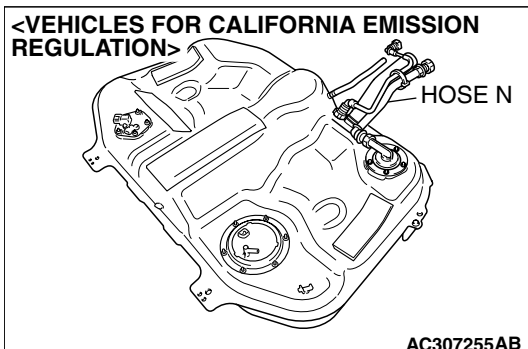
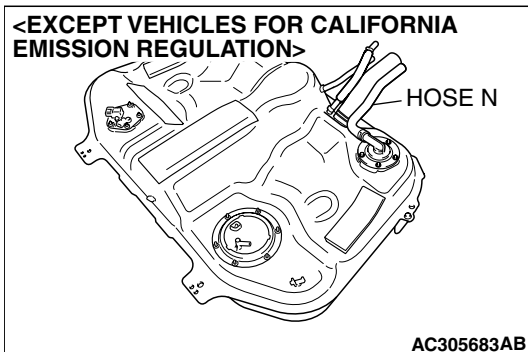

STEP 11. Check for leaks in evaporative emission hose N.

(1) Remove the fuel tank assembly (Refer to GROUP 13C, Fuel Tank [P.13C-10](#)).

(2) Use the hand vacuum pump to check the hose N.

Q: Is the hose hold vacuum?

YES : Go to Step 12.

NO : Replace the hose and reinstall the fuel tank assembly (Refer to GROUP 13C, Fuel Tank [P.13C-10](#)). Then go to Step 19.

STEP 12. Check for leaks in the fuel tank.

(1) Visually check for cracks or other leaks in the fuel tank.

NOTE: Carefully check the fuel pump module and the fuel tank differential pressure sensor installation in the fuel tank.

<EXCEPT VEHICLES FOR CALIFORNIA EMISSION REGULATION>

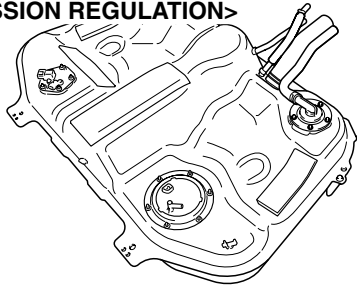

AC305683AD

<VEHICLES FOR CALIFORNIA EMISSION REGULATION>

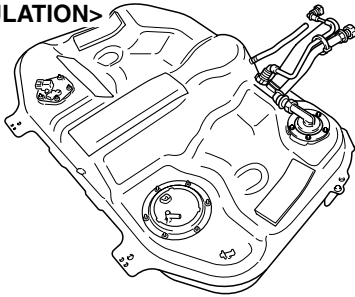

AC307255AC

<EXCEPT VEHICLES FOR CALIFORNIA EMISSION REGULATION>

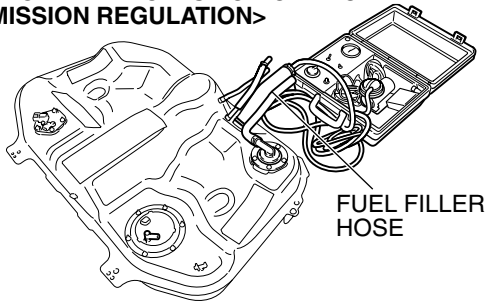

AC305684AD

<VEHICLES FOR CALIFORNIA EMISSION REGULATION>

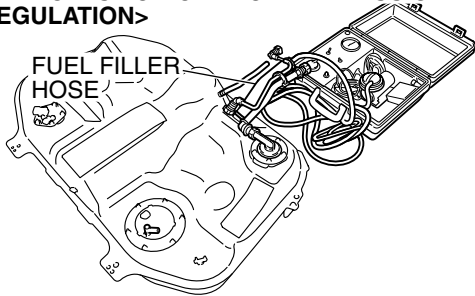

AC307256AB

<EXCEPT VEHICLES FOR CALIFORNIA EMISSION REGULATION>

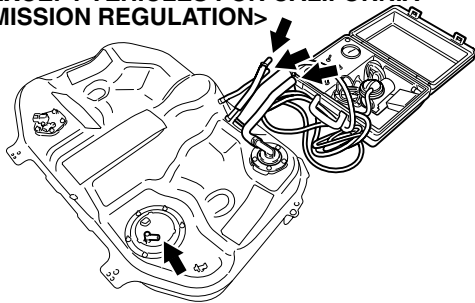

AC305684AE

<VEHICLES FOR CALIFORNIA EMISSION REGULATION>

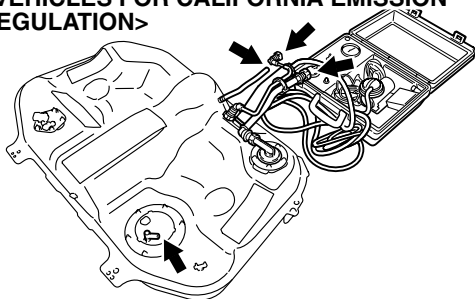

AC307256AC

- (2) Connect the evaporative emission system pressure pump (Miller number 6872A) to the fuel filler hose.

- (3) Plug the hose and the nipple shown in the illustration.
NOTE: If these items are not securely plugged now, the fuel could leak in the next step.
- (4) Pressurize the fuel tank with the evaporative emission system pressure pump.
- (5) In the pressurized state, check for leaks by applying a soapy water solution to each section and look for bubbles.

Q: Are any leaks found?

YES <When there is a leak from the attachment points of the fuel pump module, fuel tank differential pressure sensor, fuel level sensor (sub) or leveling valve.> :

Reassemble the leaked parts and check again that there are no leaks. Then reinstall the fuel tank (Refer to GROUP 13C, Fuel Tank P.13C-10). Then go to Step 19.

YES <When there is a leak from the fuel tank.> : Replace the fuel tank (Refer to GROUP 13C, Fuel Tank P.13C-10). Go to Step 19.

NO : When there is no leak, reinstall the fuel tank (Refer to GROUP 13C, Fuel Tank P.13C-10). Then go to Step 18.

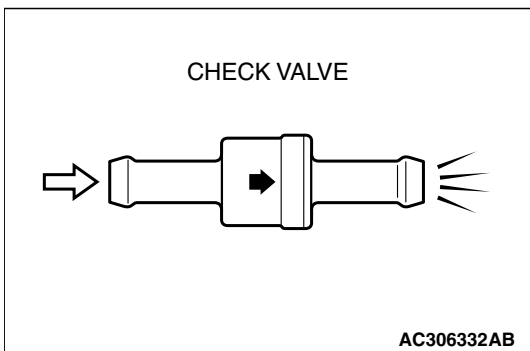
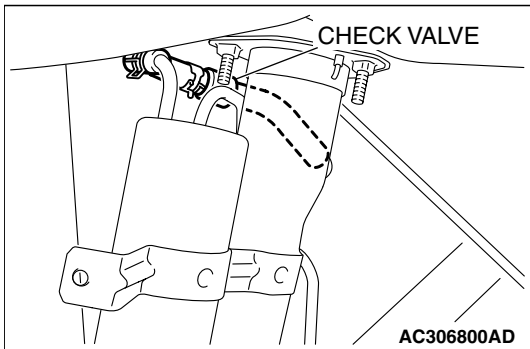
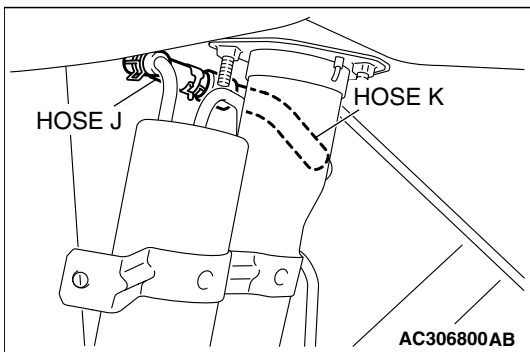
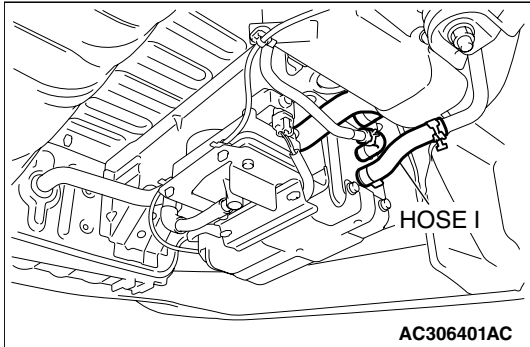

STEP 13. Check for clogging in evaporative emission system hoses I through K.

- (1) Remove the fuel tank filler tube protector (Refer to GROUP 13C, Fuel Tank P.13C-10).
- (2) Use a hand vacuum pump on each hose from hoses I to K.

Q: Are the hoses in good condition?

YES : Go to Step 14.

NO : Replace the damaged hose, and the fuel tank filler tube protector (Refer to GROUP 13C, Fuel Tank P.13C-10). Then go to Step 19.

STEP 14. Test check valve.

- (1) Check valve is a one-way check valve.

- (2) Check valve should allow air to flow in only one direction.

Q: Does check valve allow air to pass in one direction only?

YES : Go to Step 15.

NO : Replace check valve, and reinstall the fuel tank filler tube protector (Refer to GROUP 13C, Fuel Tank P.13C-10). Then go to Step 19.

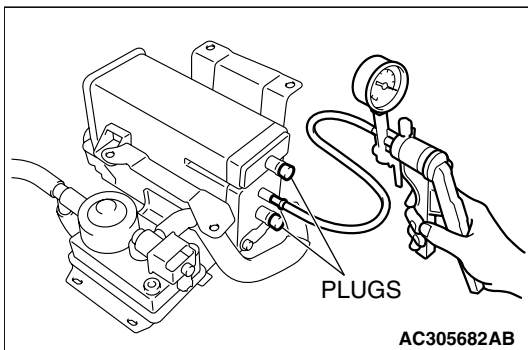
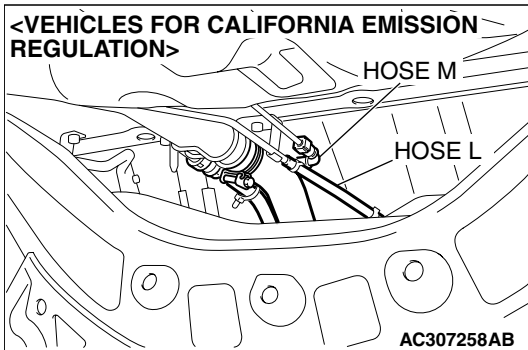
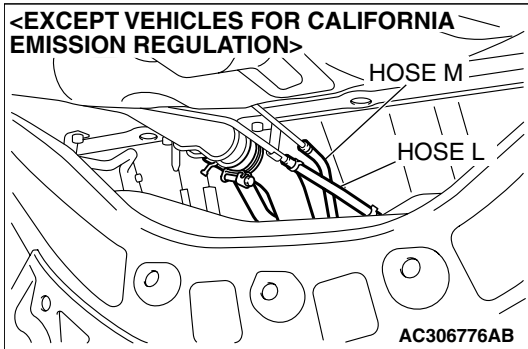

STEP 15. Check for clogging in evaporative emission hoses L and M.

Use a hand vacuum pump to test each hose L and M.

Q: Are the hoses in good condition?

YES : Go to Step 16.

NO : Replace any damaged hose. Then go to Step 19.

STEP 16. Check the evaporative emission canister for leaks and clogging.

- (1) Remove the evaporative emission canister (Refer to GROUP 17, Evaporative Emission Canister and Fuel Tank Pressure Relief Valve P.17-95).
- (2) Connect a hand vacuum pump to the evaporative emission canister and plug the other nipples.
- (3) Apply a pressure on the hand vacuum pump, and confirm that air is maintained.
- (4) When the plugs are removed, check for air leakage.
- (5) Disconnect the hand vacuum pump and install the evaporative emission canister (Refer to GROUP 17, Evaporative Emission Canister and Fuel Tank Pressure Relief Valve P.17-95).

Q: Is the evaporative emission canister in good condition?

YES : Go to Step 17.

NO : Replace the evaporative emission canister (Refer to GROUP 17, Evaporative Emission Canister and Fuel Tank Pressure Relief Valve P.17-95). Then go to Step 19 .

STEP 17. Check for clogging in evaporative emission hose N.

(1) Remove the fuel tank assembly (Refer to GROUP 13C, Fuel Tank [P.13C-10](#)).

(2) Use the hand vacuum pump to check the hose N.

Q: Is the hose in good condition?

YES : Reinstall the fuel tank assembly (Refer to GROUP 13C, Fuel Tank [P.13C-10](#)). Then go to Step 18.

NO : Replace any damaged hose and reinstall the fuel tank assembly (Refer to GROUP 13C, Fuel Tank [P.13C-10](#)). Then go to Step 19.

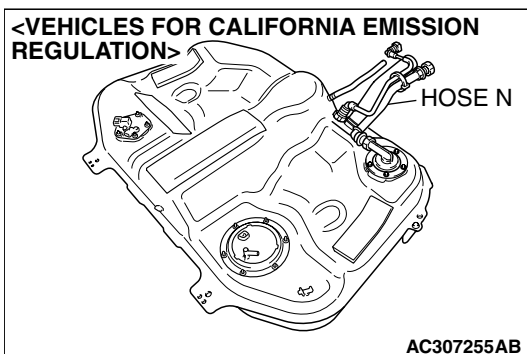
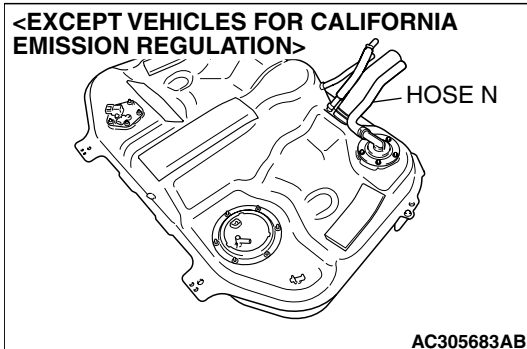

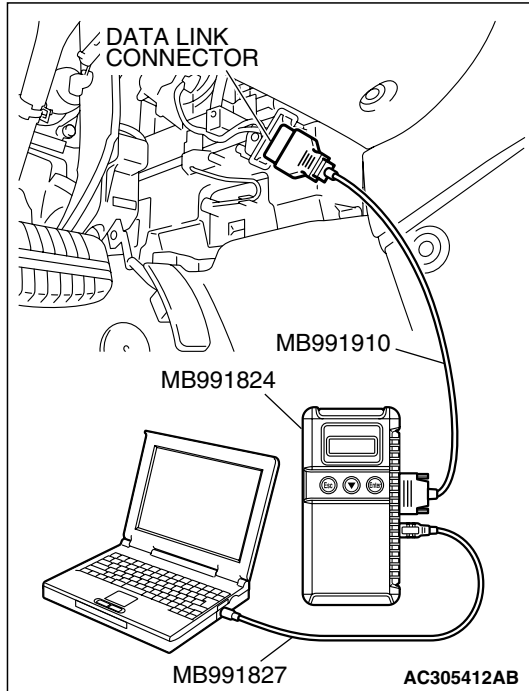

STEP 18. Using scan tool MB991958, check the evaporative emission system monitor test.

⚠ CAUTION

- To prevent damage to scan tool MB991958, always turn the ignition switch to the "LOCK" (OFF) position before connecting or disconnecting scan tool MB991958.
- During this test, the PCM automatically increases the engine speed to 1,600 r/min or greater. Check that the transaxle is set to the "P" position.

- (1) Connect scan tool MB991958 to the data link connector.
- (2) Turn the ignition switch to the "ON" position.
- (3) Erase the DTCs using scan tool MB991958.
- (4) Check that the fuel cap is securely closed (Tighten until three clicks are heard).
- (5) Start the engine.
- (6) Select "System Test."
- (7) Select "Evap Leak Mon."
- (8) During the test, keep the accelerator pedal at the idle position.
- (9) Keep the engine speed and engine load within the specified range. When the monitor test starts, the "In Progress" item on scan tool MB991958 will change from "NO" to "YES."
- (10) Turn the ignition switch to the "LOCK" (OFF) position. Disconnect scan tool MB991958.

Q: Is "Evap Leak Mon. Completed. Test Failed and DTCs Set" displayed on scan tool MB991958?

YES : Replace the PCM (Refer to [P.13A-1140](#)). Then go to Step 19 .

NO <"Evap Leak Mon. Completed. Test Passed" is displayed on scan tool MB991958.> : The evaporative emission system is working properly at this time. Go to Step 19 .

NO <"Evap Leak Mon. Discontinued. Retest again from the first" is displayed on scan tool MB991958.> : The EVAP monitor has been interrupted during the test. Turn the ignition switch to the "LOCK" (OFF) position once, and repeat the monitoring from Step 18.

STEP 19. Perform the OBD-II drive cycle.

- (1) Confirm the repair by performing the appropriate drive cycle (Refer to Diagnostic Function – OBD-II Drive Cycle – Procedure 1 – Evaporative Emission System Leak Monitor [P.13A-6](#)).
- (2) Read the DTC.

Q: Is DTC P0455 set?

YES : Repeat the troubleshooting from Step 1 .

NO : The procedure is complete.

DTC P0456: Evaporative Emission System Leak Detected (Very Small Leak)

SYSTEM DIAGRAM

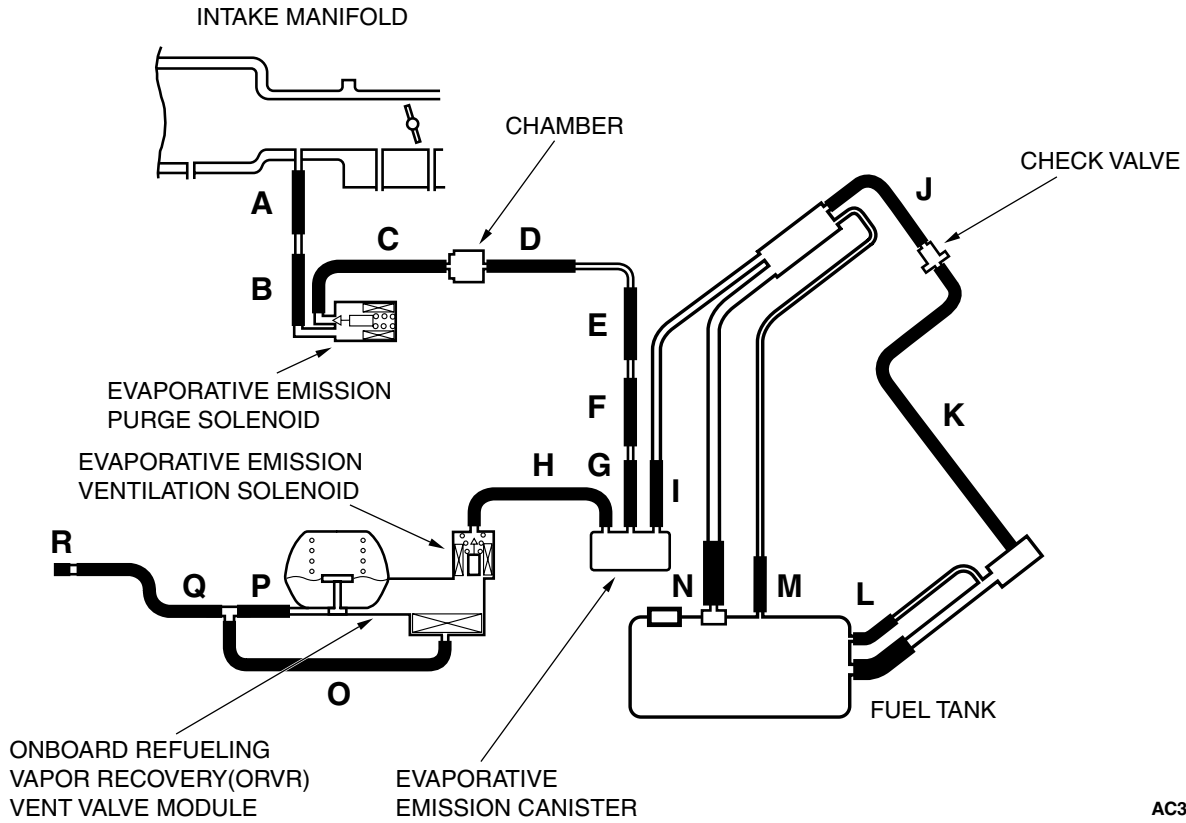

AC306277 AB

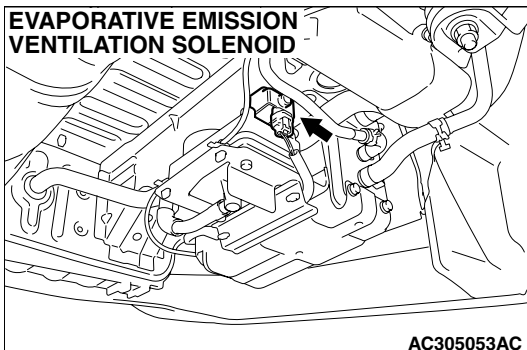
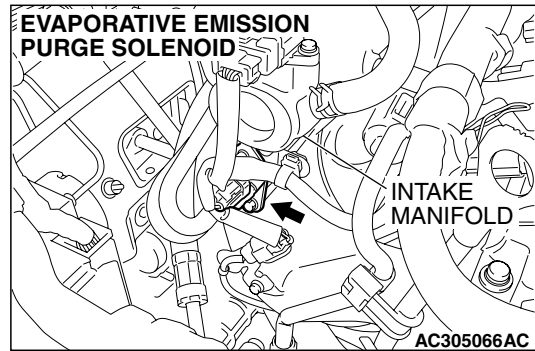
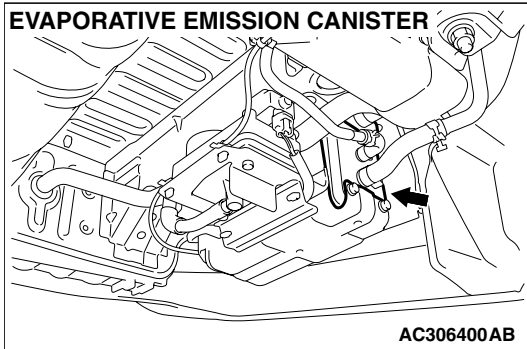

TECHNICAL DESCRIPTION

- The PCM monitors the Evaporative Emission (EVAP) System pressure.
- The PCM controls the evaporative emission ventilation solenoid. It closes the evaporative emission ventilation solenoid to seal the evaporative emission canister side of the system.
- The evaporative emission purge solenoid is opened to allow manifold vacuum to create low pressure (vacuum) in the EVAP system.
- When the EVAP system develops a vacuum of 2 kPa (0.29 psi), the evaporative emission purge solenoid is closed and the fuel system vacuum is maintained at 2 kPa (0.29 psi).
- The PCM determines whether there is a leak in the EVAP system by monitoring the vacuum inside the fuel tank.
- The test is stopped when fuel vapor pressure exceeds predetermined limits.

DESCRIPTIONS OF MONITOR METHODS

- Measure reverting pressure after depressurizing by intake manifold negative pressure and detect malfunction if reverting pressure rises largely.

MONITOR EXECUTION

- Once per driving cycle.

MONITOR EXECUTION CONDITIONS (OTHER MONITOR AND SENSOR)**Other Monitor (There is no temporary DTC stored in memory for the item monitored below)**

- Evaporative emission purge solenoid monitor
- Evaporative emission purge system monitor
- Fuel tank differential pressure sensor monitor
- Evaporative emission ventilation solenoid monitor
- Fuel level sensor monitor
- Fuel temperature sensor monitor

Sensor (The sensors below are determined to be normal)

- Mass airflow sensor
- Barometric pressure sensor
- Intake air temperature sensor
- Engine coolant temperature sensor

LOGIC FLOW CHARTS (Monitor Sequence)

0.04in, 0.02in GROSS LEAK MONITOR

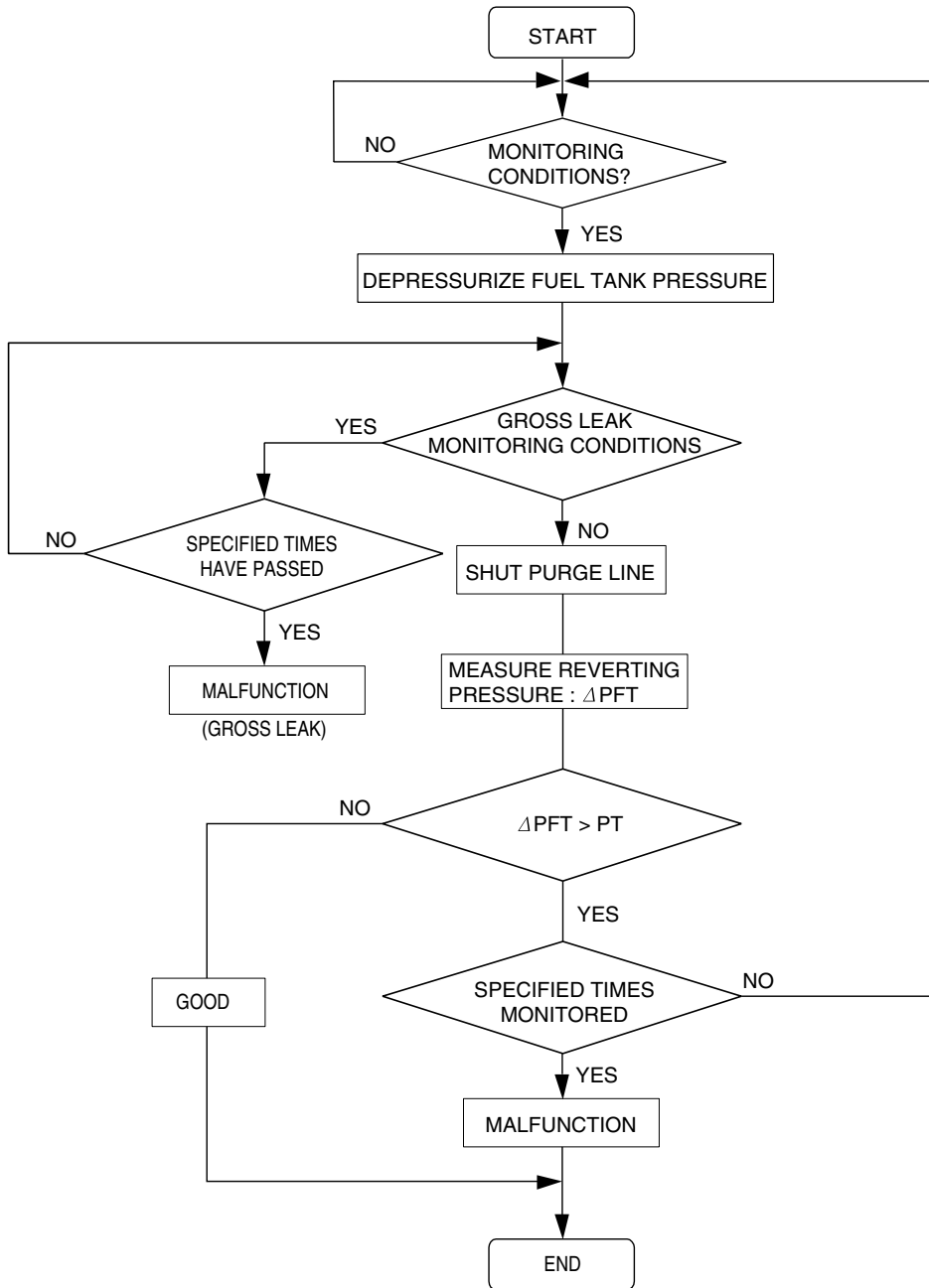

AC306649

DTC SET CONDITIONS

Check Conditions A: At Start up

- Intake air temperature is 36°C (97°F) or less when the engine is started.

- The engine coolant temperature is 36°C (97°F) or less when the engine is started.
- The fuel level sensor output voltage is 2.4 – 3.7 volts when the engine starts and the amount of remaining fuel is 40 – 85 percent of capacity.

Check Conditions B: For Test to Run

- Barometric pressure is greater than 76 kPa (11 psi).
- The fuel tank temperature is 33°C (91°F) or less.
- Fuel tank differential pressure sensor output voltage is 1 to 4 volts.

Check Conditions C: For Test to Stop

- Engine coolant temperature is greater than 20 °C (68 °F).
- Intake air temperature is greater than -10 °C (14 °F).
- When the evaporative emission purge solenoid and evaporative emission ventilation solenoid are closed, the pressure rises in the fuel tank is less than 324 Pa (0.047 psi).
- 10 seconds have elapsed from the start of the previous monitoring.
- Monitoring time: 10 – 14 minutes.

Judgment Criteria

- Internal pressure of the fuel tank has changed more than 1,177 – 1,373 Pa (0.177 – 0.199 psi) in 128 seconds after the tank and vapor line were closed.

OBD-II DRIVE CYCLE PATTERN

Refer to Diagnostic Function – OBD-II Drive Cycle – Procedure 1 – Evaporative Emission System Leak Monitor [P.13A-6](#).

TROUBLESHOOTING HINTS (THE MOST LIKELY CAUSES FOR THIS CODE TO BE SET ARE:)

- Loose fuel cap.
- Fuel cap relief pressure is incorrect.
- Malfunction of the evaporative emission canister seal.
- Malfunction of the fuel tank, purge line or vapor line seal.
- Malfunction of the evaporative emission ventilation solenoid.

DIAGNOSIS

Required Special Tools:

- MB991958: Scan Tool (MUT-III Sub Assembly)
 - MB991824: V.C.I.
 - MB991827: MUT-III USB Cable
 - MB991910: MUT-III Main Harness A

STEP 1. Using scan tool MB991958, check the evaporative emission system monitor test.

⚠ CAUTION

- To prevent damage to scan tool MB991958, always turn the ignition switch to the "LOCK" (OFF) position before connecting or disconnecting scan tool MB991958.
- During this test, the PCM will automatically increase the engine speed to 1,600 r/min or greater. Check that the transaxle is set to the "P" position.

- (1) Connect scan tool MB991958 to the data link connector.
- (2) Turn the ignition switch to the "ON" position.
- (3) Erase the DTCs using scan tool MB991958.
- (4) Check that the fuel cap is securely closed (Tighten until three clicks are heard).
- (5) Start the engine.
- (6) Select "System Test."
- (7) Select "Evap Leak Mon."
- (8) During this test, keep the accelerator pedal at the idle position.
- (9) Keep the engine speed and engine load within the specified range. When the monitor test starts, the "In Progress" item on scan tool MB991958 will change from "NO" to "YES."
- (10) Turn the ignition switch to the "LOCK" (OFF) position, and disconnect scan tool MB991958.

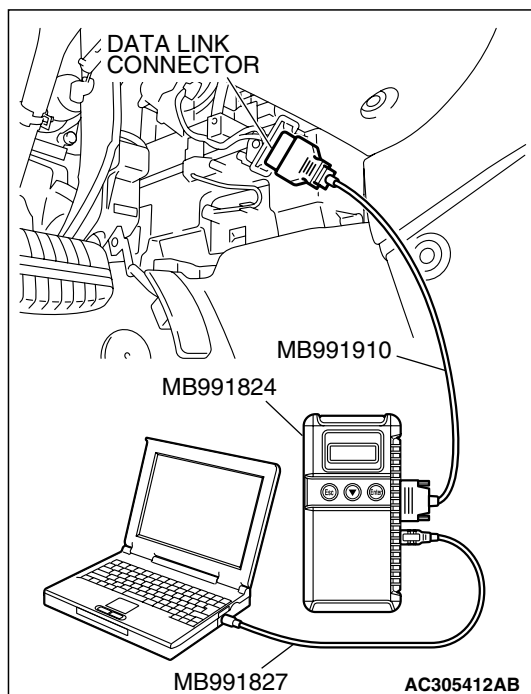

Q: Is "Evap Leak Mon. Completed. Test Failed and DTCs Set" displayed on scan tool MB991958?

YES : A malfunction has been detected during the monitor test. Refer to the Diagnostic Trouble Code Chart and diagnose any other DTCs that are set [P.13A-33](#). If no other DTC's have been set, go to Step 2.

NO <"Evap Leak Mon. Completed. Test Passed" is displayed on scan tool MB991958.> : The evaporative emission system is working properly at this time. Explain to the customer that an improperly tightened fuel cap can cause the MIL to illuminate. Return the vehicle to the customer.

NO <"Evap Leak Mon. Discontinued. Retest again from the first" is displayed on scan tool MB991958.> : The EVAP monitor has been interrupted during the test. Turn the ignition switch to the "LOCK" (OFF) position once, and repeat the monitoring from Step 1.

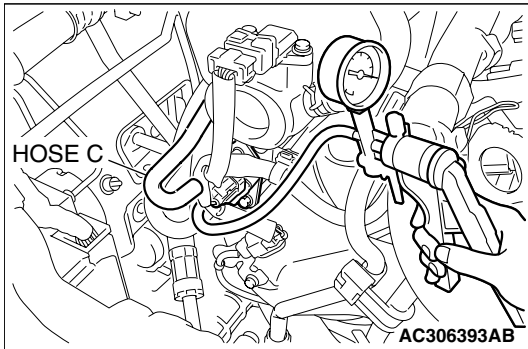

STEP 2. Check the evaporative emission purge solenoid for leaks.

- (1) Disconnect hose C from the evaporative emission purge solenoid and connect a hand vacuum pump to the nipple of the evaporative emission purge solenoid.
- (2) Use the hand vacuum pump to confirm that the evaporative emission purge solenoid holds vacuum.
- (3) Disconnect the hand vacuum pump, and reconnect hose C to the evaporative emission purge solenoid.

Q: Does the evaporative emission purge solenoid hold vacuum?

YES : Go to Step 3.

NO : Replace the evaporative emission purge solenoid.
Then go to Step 15.

STEP 3. Check for leaks in evaporative emission hoses A through E.

Use a hand vacuum pump to test each hose from hose A to hose E.

Q: Do the hoses hold vacuum?

YES : Go to Step 4.

NO : Replace any damaged hose. Then go to Step 15.

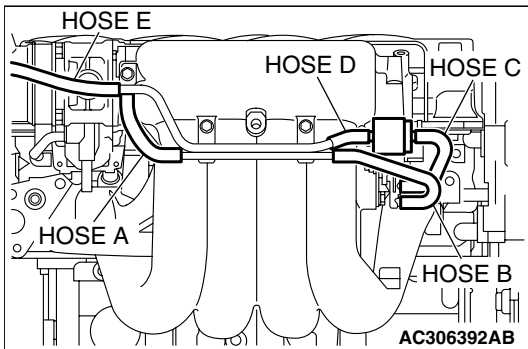

STEP 4. Check for leaks in the chamber.

- (1) Connect a hand vacuum pump to the nipple.
- (2) Plug the other nipple.
- (3) Apply vacuum with the hand vacuum pump, and confirm that the applied vacuum does not fluctuate.

Q: Is the chamber in good condition?

YES : Go to Step 5.

NO : Replace the chamber. Then go to Step 15.

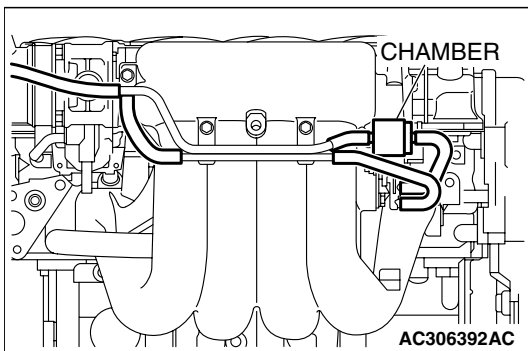

STEP 5. Check for leaks in evaporative emission hoses F through H.

Use a hand vacuum pump to test each hose from hose F to hose H.

Q: Do the hoses hold vacuum?

YES : Go to Step 6.

NO : Replace any damaged hose. Then go to Step 15.

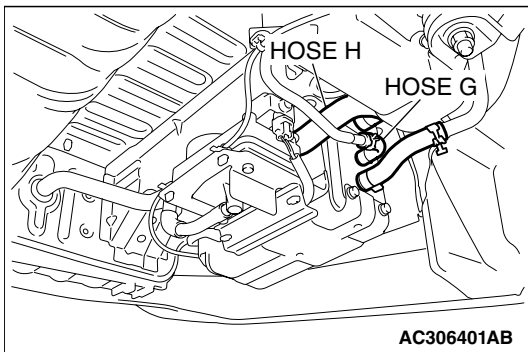
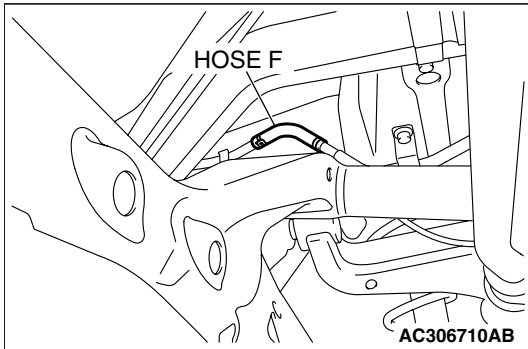

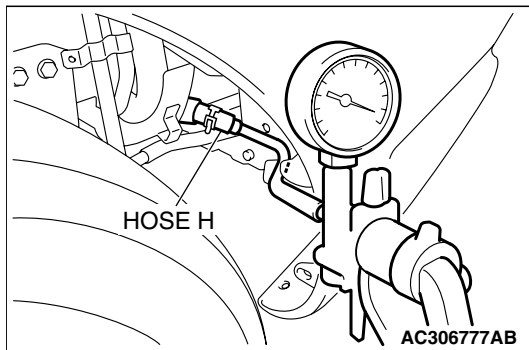
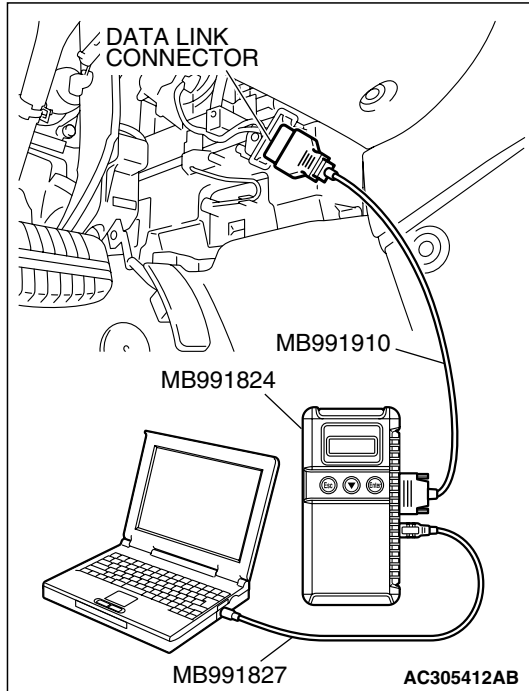

STEP 6. Using scan tool MB991958, check data list item 29: Evaporative emission ventilation solenoid.

CAUTION

To prevent damage to scan tool MB991958, always turn the ignition switch to the "LOCK" (OFF) position before connecting or disconnecting scan tool MB991958.

- (1) Connect scan tool MB991958 to the data link connector.
- (2) Remove the fuel tank filler tube protector (Refer to GROUP 13C, Fuel Tank P.13C-10).

- (3) Disconnect hose H from evaporative emission canister and connect hand vacuum pump to hose H.
- (4) Turn the ignition switch to the "ON" position.
- (5) Set scan tool MB991958 to actuator test mode.
 - Item 29: Evaporative Emission Ventilation Solenoid.
 - While the evaporative emission ventilation solenoid is energized, operate the hand vacuum pump and confirm that the solenoid holds vacuum.
- (6) Turn the ignition switch to the "LOCK" (OFF) position, and disconnect scan tool MB991958.
- (7) Disconnect the hand vacuum pump, and connect hose H to the evaporative emission canister.
- (8) Reinstall the fuel tank filler tube protector (Refer to GROUP 13C, Fuel Tank P.13C-10).

Q: Did the evaporative emission ventilation solenoid hold vacuum?

YES : Go to Step 7.

NO : Replace the evaporative emission ventilation solenoid (Refer to GROUP 17, Evaporative emission canister and fuel tank pressure relief valve removal and installation P.17-95). Then go to Step 15.

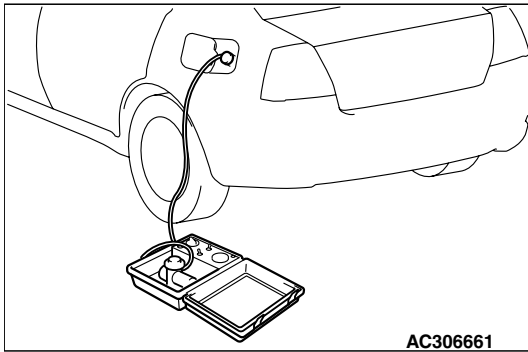
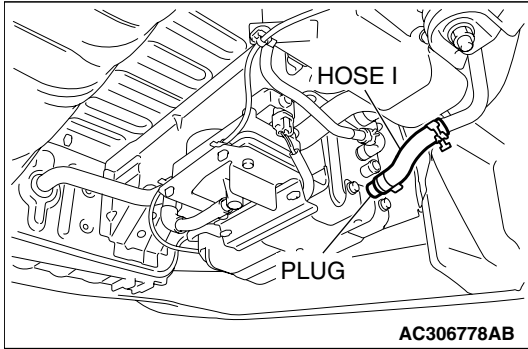

STEP 7. Pressure test the evaporative emission system lines from hoses I to N.

- (1) Disconnect hose I from the evaporative emission canister, and plug hose I securely.
- (2) Confirm that the evaporative emission system pressure pump (Miller number 6872A) is operating properly. Perform the self-test as described in the pump manufacturer's instructions.
- (3) Remove the fuel cap.

- (4) Connect the evaporative emission system pressure pump (Miller number 6872A) to the fuel tank filler tube by using fuel tank adapter (MLR-8382).
- (5) Pressure test the system to determine whether any leaks are present.

NOTE: The "Pressure test" in this procedure refers to the I/M240 Simulation Test. The eight steps of this test are described in the manufacturer's instructions for the evaporative emission system pressure pump, Miller number 6872A.

- (6) Remove the evaporative emission system pressure pump (Miller number 6872A) and the fuel tank adapter (MLR-8382), and reinstall the fuel cap.
- (7) Connect hose I to the evaporative emission canister.

Q: Is the evaporative emission system line free of leaks?

YES : Go to Step 13.

NO : Go to Step 8.

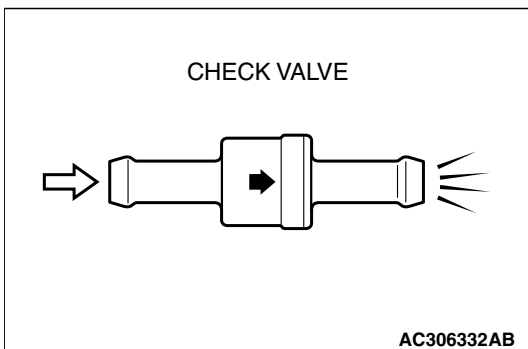
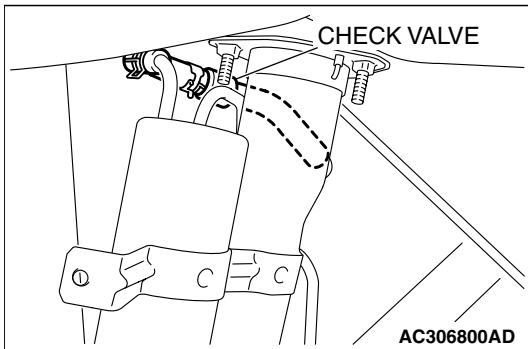
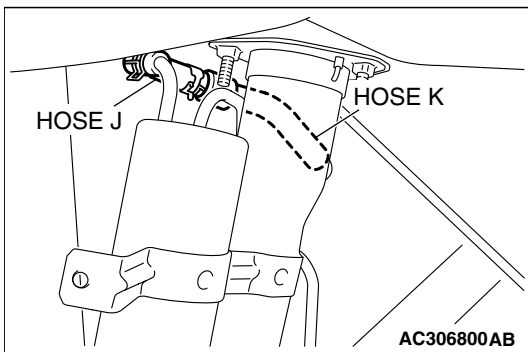
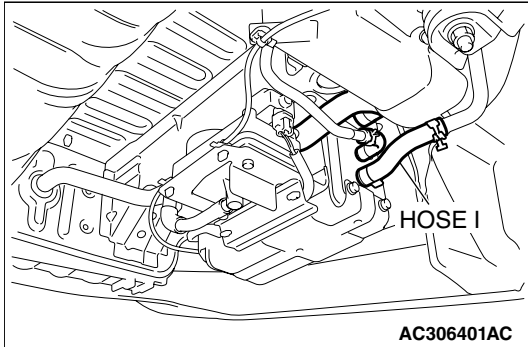

STEP 8. Check for leaks in evaporative emission hoses I through K.

- (1) Remove the fuel tank filler tube protector (Refer to GROUP 13C, Fuel Tank [P.13C-10](#)).
- (2) Use a hand vacuum pump to test each hose from hose I to hose K.

Q: Do the hoses hold vacuum?

YES : Go to Step 9.

NO : Replace any damaged hose. Then go to Step 15.

STEP 9. Test check valve.

- (1) Check valve is a one-way check valve.

- (2) Check valve should allow air to flow in only one direction.

Q: Does check valve allow air to pass in one direction only?

YES : Go to Step 10.

NO : Replace check valve, and reinstall the fuel tank filler tube protector (Refer to GROUP 13C, Fuel Tank [P.13C-10](#)). Then go to Step 15.

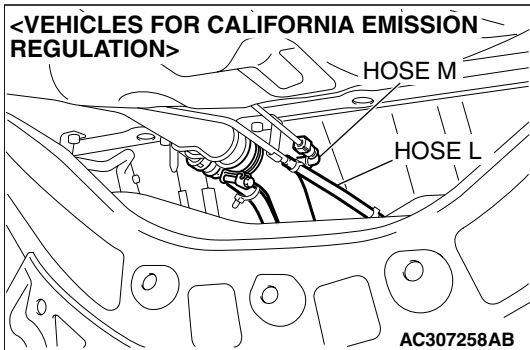
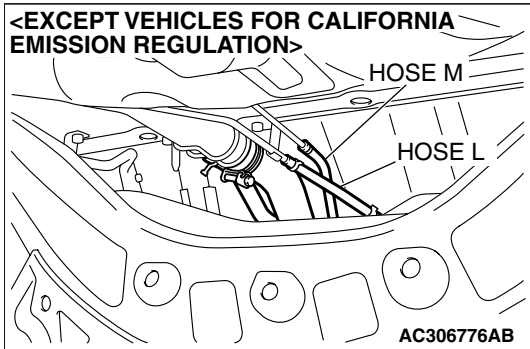

STEP 10. Check for leaks in evaporative emission hoses L and M.

Use a hand vacuum pump to test each hose L and M.

Q: Do the hoses hold vacuum?

YES : Go to Step 11.

NO : Replace any damaged hose. Then go to Step 15.

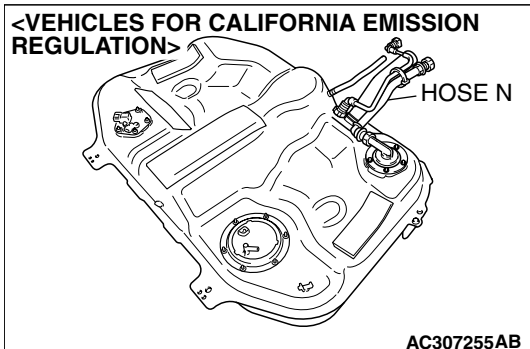
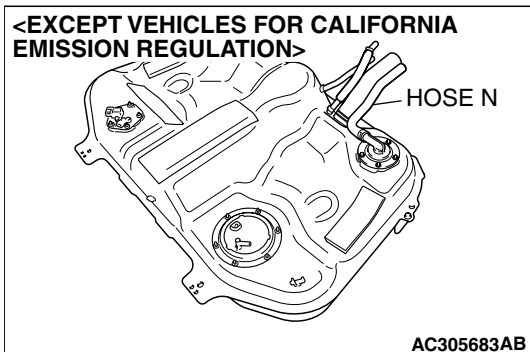

STEP 11. Check for leaks in evaporative emission hose N.

(1) Remove the fuel tank assembly (Refer to GROUP 13C, Fuel Tank [P.13C-10](#)).

(2) Use the hand vacuum pump to check the hose N.

Q: Is the hose hold vacuum?

YES : Go to Step 12.

NO : Replace the hose and reinstall the fuel tank assembly (Refer to GROUP 13C, Fuel Tank [P.13C-10](#)). Then go to Step 15.

STEP 12. Check for leaks in the fuel tank.

(1) Visually check for cracks or other leaks in the fuel tank.

NOTE: Carefully check the fuel pump module and the fuel tank differential pressure sensor installation in the fuel tank.

<EXCEPT VEHICLES FOR CALIFORNIA EMISSION REGULATION>

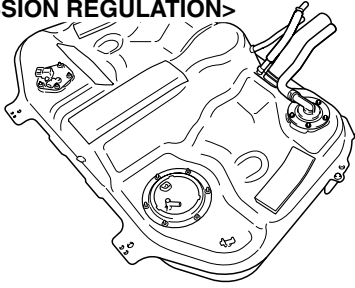

AC305683AD

<VEHICLES FOR CALIFORNIA EMISSION REGULATION>

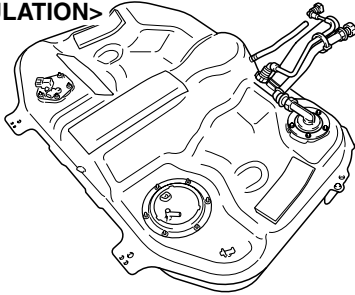

AC307255AC

<EXCEPT VEHICLES FOR CALIFORNIA EMISSION REGULATION>

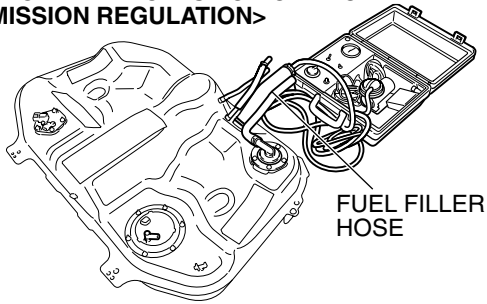

AC305684AD

- (2) Connect the evaporative emission system pressure pump (Miller number 6872A) to the fuel filler hose.

<VEHICLES FOR CALIFORNIA EMISSION REGULATION>

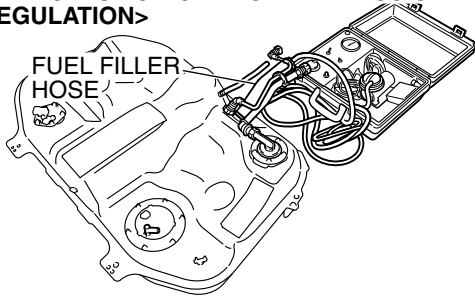

AC307256AB

<EXCEPT VEHICLES FOR CALIFORNIA EMISSION REGULATION>

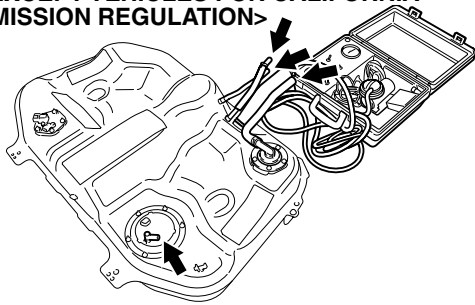

AC305684AE

- (3) Plug the hose and the nipple shown in the illustration.
NOTE: If these items are not securely plugged now, the fuel could leak in the next step.
- (4) Pressurize the fuel tank with the evaporative emission system pressure pump.
- (5) In the pressurized state, check for leaks by applying a soapy water solution to each section and look for bubbles.

Q: Are any leaks found?

YES <When there is a leak from the attachment points of the fuel pump module, fuel tank differential pressure sensor, fuel level sensor (sub) or leveling valve.> :

Reassemble the leaked parts and check again that there are no leaks. Then reinstall the fuel tank (Refer to GROUP 13C, Fuel Tank P.13C-10). Then go to Step 15 .

YES <When there is a leak from the fuel tank.> : Replace the fuel tank (Refer to GROUP 13C, Fuel Tank P.13C-10). Go to Step 15.

NO : When there is no leak, reinstall the fuel tank (Refer to GROUP 13C, Fuel Tank P.13C-10). Then go to Step 14.

<VEHICLES FOR CALIFORNIA EMISSION REGULATION>

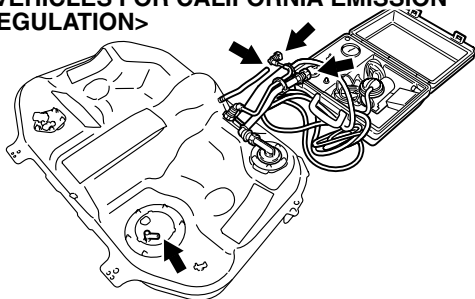

AC307256AC

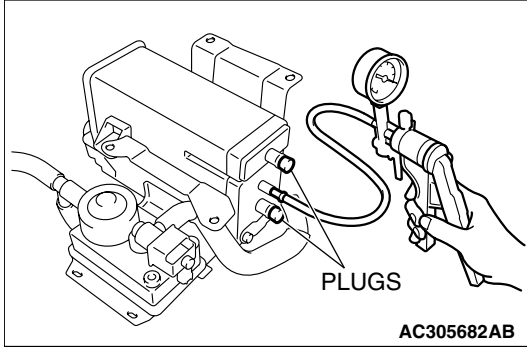
**STEP 13. Check the evaporative emission canister for vacuum leaks.**

- (1) Remove the evaporative emission canister (Refer to GROUP 17, Evaporative Emission Canister and Fuel Tank Pressure Relief Valve [P.17-95](#)).
- (2) Connect a hand vacuum pump to the evaporative emission canister and plug the other nipples.
- (3) Apply a pressure on the hand vacuum pump, and confirm that air is maintained.
- (4) Disconnect the hand vacuum pump and remove the plugs, and then install the evaporative emission canister (Refer to GROUP 17, Evaporative Emission Canister and Fuel Tank Pressure Relief Valve [P.17-95](#)).

Q: Is the evaporative emission canister in good condition?**YES :** Go to Step 14.**NO :** Replace the evaporative emission canister (Refer to GROUP 17, Evaporative Emission Canister and Fuel Tank Pressure Relief Valve [P.17-95](#)). Then go to Step 15 .

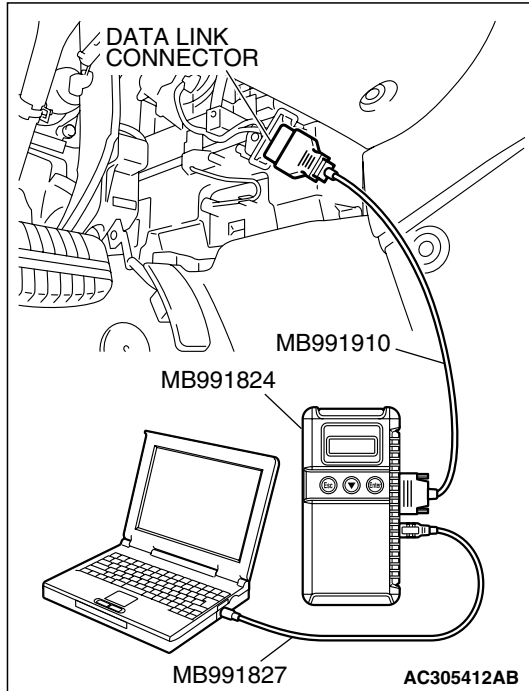

STEP 14. Using scan tool MB991958, check the evaporative emission system monitor test.

⚠ CAUTION

- To prevent damage to scan tool MB991958, always turn the ignition switch to the "LOCK" (OFF) position before connecting or disconnecting scan tool MB991958.
- During this test, the PCM automatically increases the engine speed to 1,600 r/min or greater. Check that the transaxle is set to the "P" position.

- (1) Connect scan tool MB991958 to the data link connector.
- (2) Turn the ignition switch to the "ON" position.
- (3) Erase the DTCs using scan tool MB991958.
- (4) Check that the fuel cap is securely closed (Tighten until three clicks are heard).
- (5) Start the engine.
- (6) Select "System Test."
- (7) Select "Evap Leak Mon."
- (8) During the test, keep the accelerator pedal at the idle position.
- (9) Keep the engine speed and engine load within the specified range. When the monitor test starts, the "In Progress" item on scan tool MB991958 will change from "NO" to "YES."
- (10) Turn the ignition switch to the "LOCK" (OFF) position. Disconnect scan tool MB991958.

Q: Is "Evap Leak Mon. Completed. Test Failed and DTCs Set" displayed on scan tool MB991958?

YES : Replace the PCM (Refer to [P.13A-1140](#)). Then go to Step 15 .

NO <"Evap Leak Mon. Completed. Test Passed" is displayed on scan tool MB991958.> : The evaporative emission system is working properly at this time. Go to Step 15 .

NO <"Evap Leak Mon. Discontinued. Retest again from the first" is displayed on scan tool MB991958.> : The EVAP monitor has been interrupted during the test. Turn the ignition switch to the "LOCK" (OFF) position once, and repeat the monitoring from Step 14.

STEP 15. Perform the OBD-II drive cycle.

- (1) Confirm the repair by performing the appropriate drive cycle (Refer to Diagnostic Function – OBD-II Drive Cycle – Procedure 1 – Evaporative Emission System Leak Monitor [P.13A-6](#)).
- (2) Read the DTC.

Q: Is DTC P0456 set?

YES : Repeat the troubleshooting from Step 1 .

NO : The procedure is complete.

DTC P0461: Fuel Level Sensor (main) Circuit Range/Performance

Fuel Level Sensor Circuit

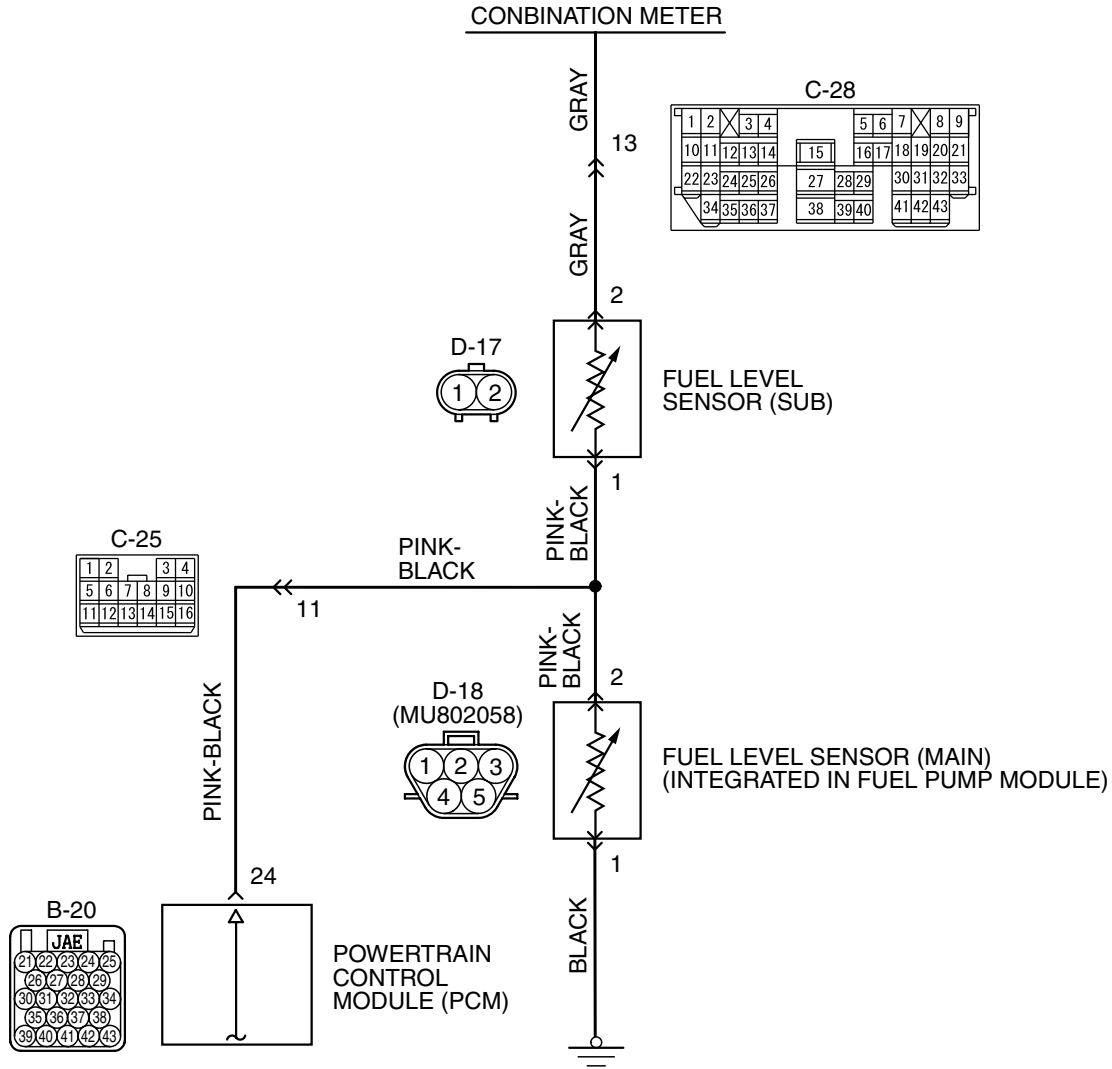

AK400894

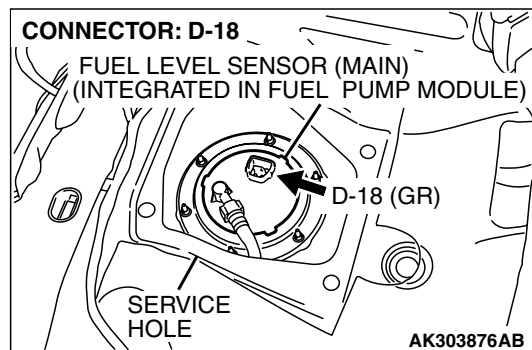
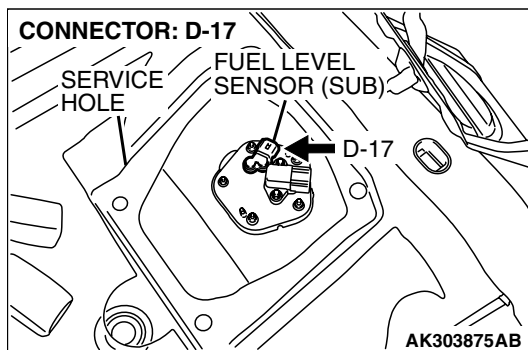

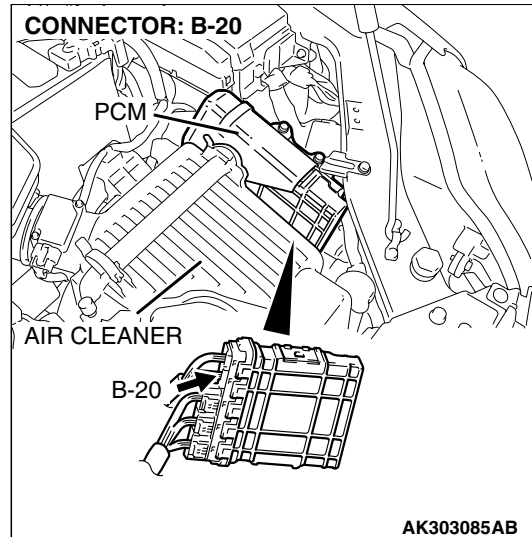
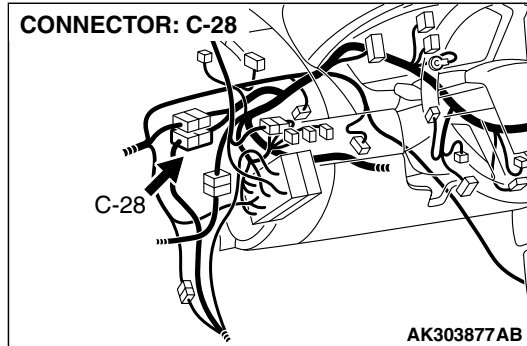
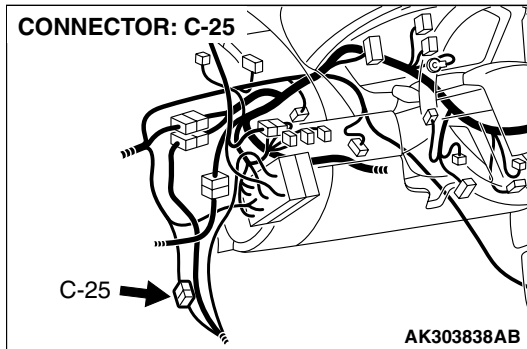

CIRCUIT OPERATION

- The fuel level sensor (main) output voltage is input in PCM (terminal No. 24).

TECHNICAL DESCRIPTION

- Branch the output voltage from the fuel level sensor circuit, and input it into PCM.
- The PCM detects the amount of fuel left in the fuel tank with this signal, and also controls the fuel level warning light.

DESCRIPTIONS OF MONITOR METHODS

Detect malfunction if change of fuel level sensor output voltage is small when sum of fuel injection is large.

MONITOR EXECUTION

Continuous

MONITOR EXECUTION CONDITIONS (Other monitor and Sensor)

Other Monitor (There is no temporary DTC stored in memory for the item monitored below)

- Not applicable

Sensor (The sensor below is determined to be normal)

- Not applicable

DTC SET CONDITIONS

Logic Flow Chart

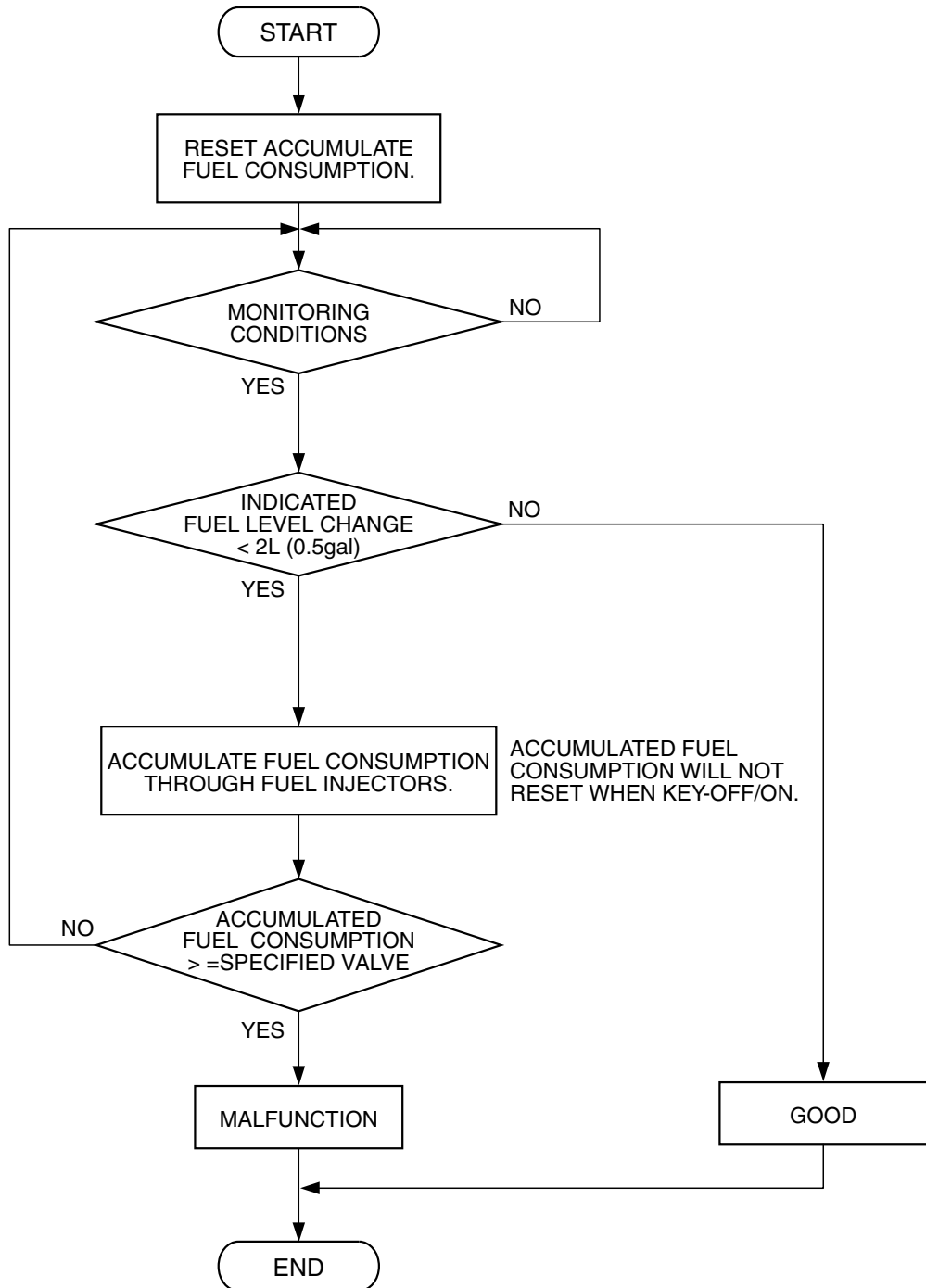

AK302040

Check Conditions, Judgement Criteria

- When the fuel consumption calculated from the operation time of the injector amounts to 30 liters, the diversity of the amount of fuel in tank calculated from the fuel level sensor is 2 liters or less.

OBD-II DRIVE CYCLE PATTERN

Refer to Diagnostic Function – OBD-II Drive Cycle – Procedure 6 – Other Monitor [P.13A-6](#).

TROUBLESHOOTING HINTS (The most likely causes for this code to be set are:)

- Fuel pump module or fuel level sensor failed.
- Harness damage or connector damage in fuel level sensor circuit.
- PCM failed.

DIAGNOSIS

Required Special Tools:

- MB991958: Scan tool (MUT-III Sub Assembly)
 - MB991824: V.C.I.
 - MB991827: USB Cable
 - MB991910: Main Harness A

STEP 1. Using scan tool MB991958, read the diagnostic trouble code (DTC).

CAUTION

To prevent damage to scan tool MB991958, always turn the ignition switch to the "LOCK" (OFF) position before connecting or disconnecting scan tool MB991958.

- (1) Connect scan tool MB991958 to the data link connector.
- (2) Turn the ignition switch to the "ON" position.
- (3) Read the DTC.
- (4) Turn the ignition switch to the "LOCK" (OFF) position.

Q: Is DTC P2066 set?

- YES :** Go to Step 2.
NO : Go to Step 4.

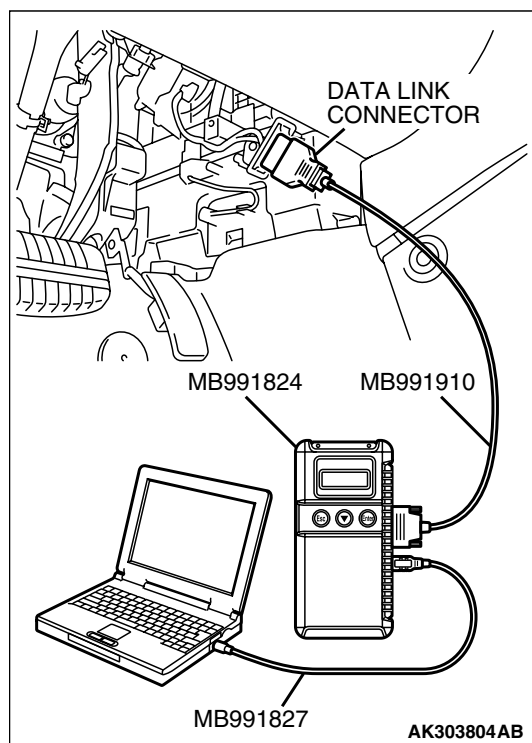

STEP 2. Check fuel gauge.

Q: Is the fuel gauge functioning?

- YES :** Go to Step 3.
NO : Refer to GROUP 54A, Chassis Electrical – Combination Meters Assembly and Vehicle Speed Sensor – Symptom Chart [P.54A-16](#).

STEP 3. Check the trouble symptoms.

- (1) Carry out a test drive with the drive cycle pattern. Refer to Diagnostic Function – OBD-II Drive Cycle – Procedure 6 – Other Monitor [P.13A-6](#).
- (2) Check the diagnostic trouble code (DTC).

Q: Is DTC P0461 set?

- YES :** Replace the PCM. Then go to Step 8.
- NO :** It can be assumed that this malfunction is intermittent. Refer to GROUP 00, How to Use Troubleshooting/Inspection Service Points – How to Cope with Intermittent Malfunctions [P.00-14](#).

STEP 4. Check harness connector D-18 at fuel level sensor (main) and harness connector B-20 at PCM for damage.

Q: Is the harness connector in good condition?

- YES :** Go to Step 5.
- NO :** Repair or replace it. Refer to GROUP 00E, Harness Connector Inspection [P.00E-2](#). Then go to Step 8.

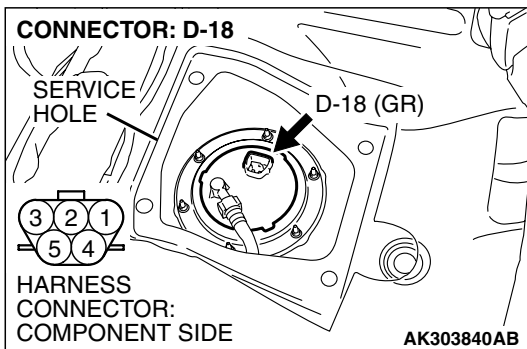
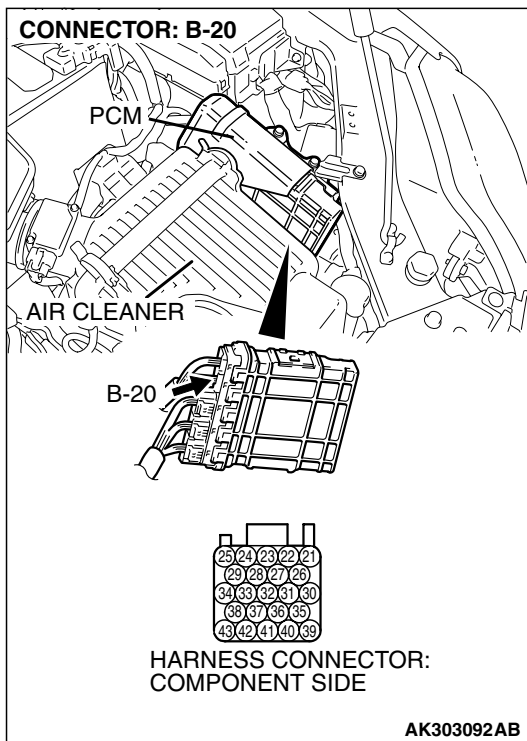

STEP 5. Check for harness damage between fuel level sensor (main) connector D-18 (terminal No. 2) and PCM connector B-20 (terminal No. 24).

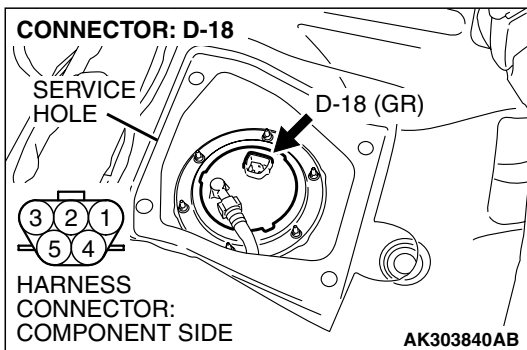
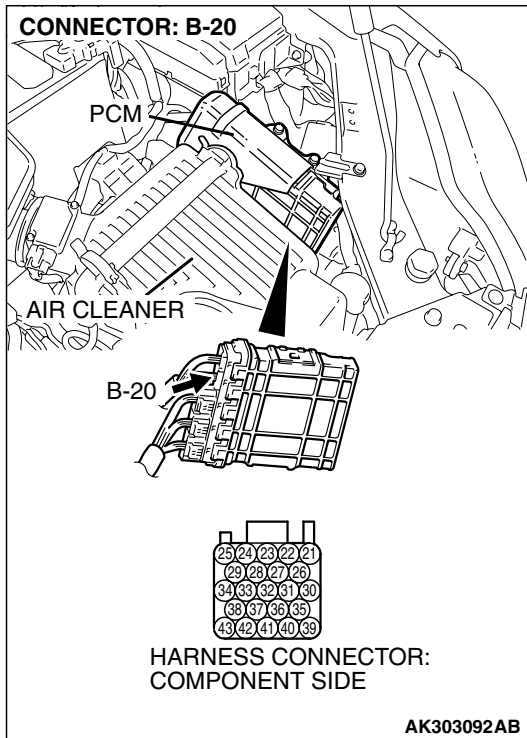

NOTE: Check harness after checking intermediate connector C-25. If intermediate connector is damaged, repair or replace it. Refer to GROUP 00E, Harness Connector Inspection P. 00E-2. Then go to Step 8.

Q: Is the harness wire in good condition?

YES : Go to Step 6.

NO : Repair it. Then go to Step 8.

STEP 6. Check the fuel pump module.

Check to see if the fuel pump module is normal. Refer to GROUP 54A, Chassis Electrical – Combination Meters Assembly and Vehicle Speed Sensor – On-Vehicle Service – Fuel Level Sensor Check [P.54A-104](#).

Q: Is the fuel pump module normal?

YES : Go to Step 7.

NO : Replace the fuel pump module. Then go to Step 8.

STEP 7. Check the trouble symptoms.

(1) Carry out a test drive with the drive cycle pattern. Refer to Diagnostic Function – OBD-II Drive Cycle – Procedure 6 – Other Monitor [P.13A-6](#).

(2) Check the diagnostic trouble code (DTC).

Q: Is DTC P0461 set?

YES : Replace the PCM. Then go to Step 8.

NO : It can be assumed that this malfunction is intermittent. Refer to GROUP 00, How to Use Troubleshooting/Inspection Service Points – How to Cope with Intermittent Malfunctions [P.00-14](#).

STEP 8. Test the OBD-II drive cycle.

(1) Carry out a test drive with the drive cycle pattern. Refer to Diagnostic Function – OBD-II Drive Cycle – Procedure 6 – Other Monitor [P.13A-6](#).

(2) Check the diagnostic trouble code (DTC).

Q: Is DTC P0461 set?

YES : Retry the troubleshooting.

NO : The inspection is complete.

DTC P0462: Fuel Level Sensor Circuit Low Input

Fuel Level Sensor Circuit

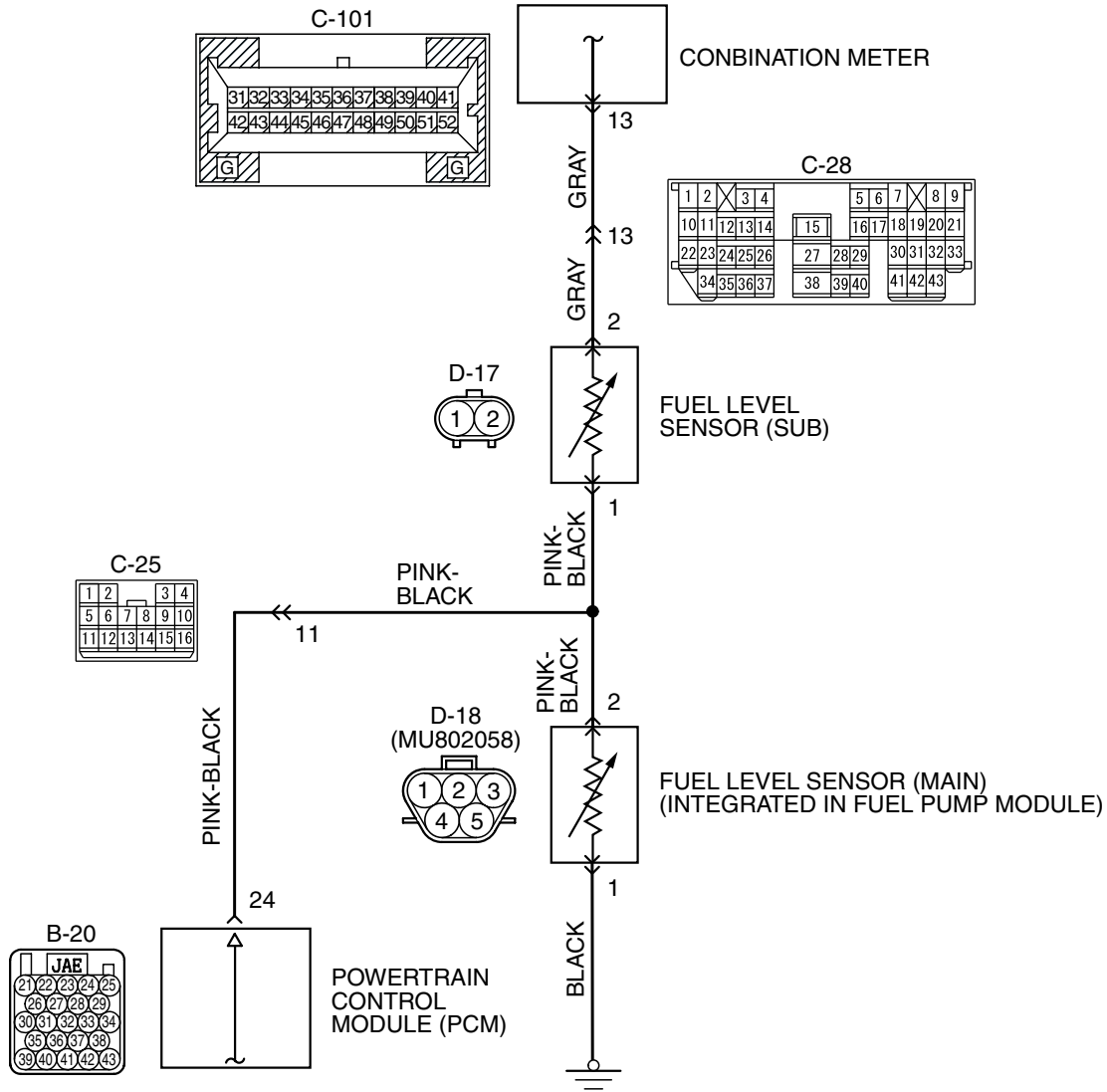

AK401489

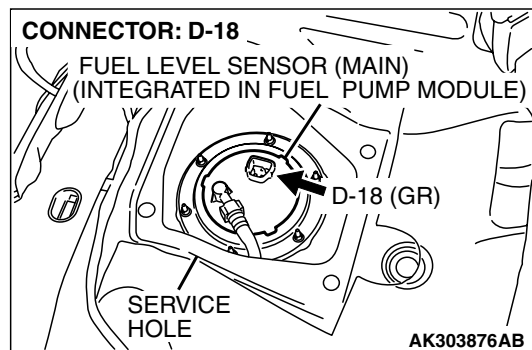
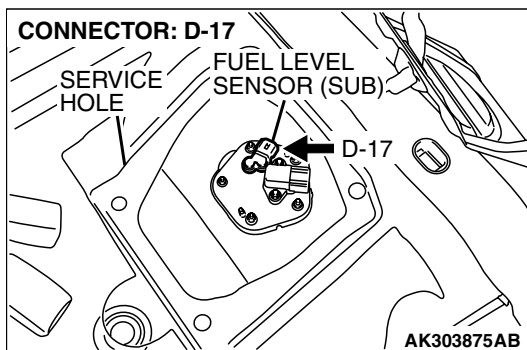

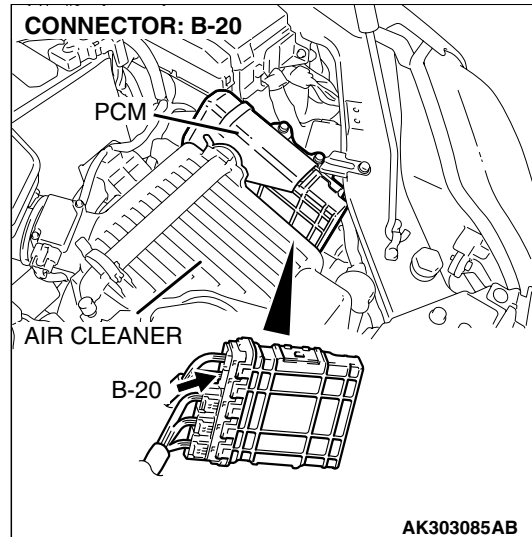
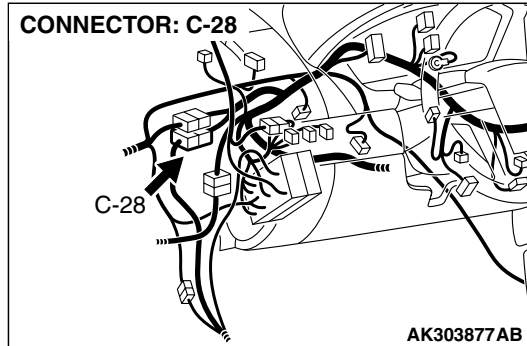
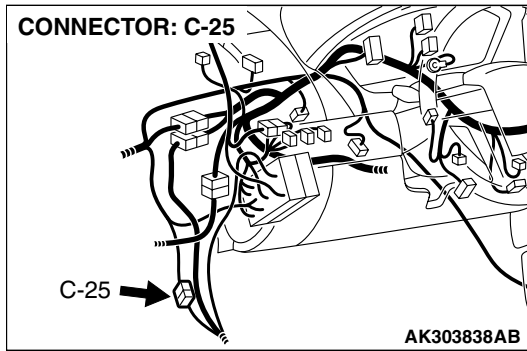

CIRCUIT OPERATION

- The fuel level sensor output voltage is input in combination meter (terminal No. 13).

TECHNICAL DESCRIPTION

- The fuel level sensor converts the rest of the fuel to a voltage.
- The combination meter sends the data regarding the rest of the fuel to the PCM.
- The PCM checks whether this data is within a specified range.

DESCRIPTIONS OF MONITOR METHODS

A short circuit is detected while monitoring the fuel level sensor output.

MONITOR EXECUTION

Continuous

**MONITOR EXECUTION CONDITIONS
(Other monitor and Sensor)**

Other Monitor (There is no temporary DTC stored in memory for the item monitored below)

- Not applicable

Sensor (The sensor below is determined to be normal)

- Not applicable

DTC SET CONDITIONS

Logic Flow Chart

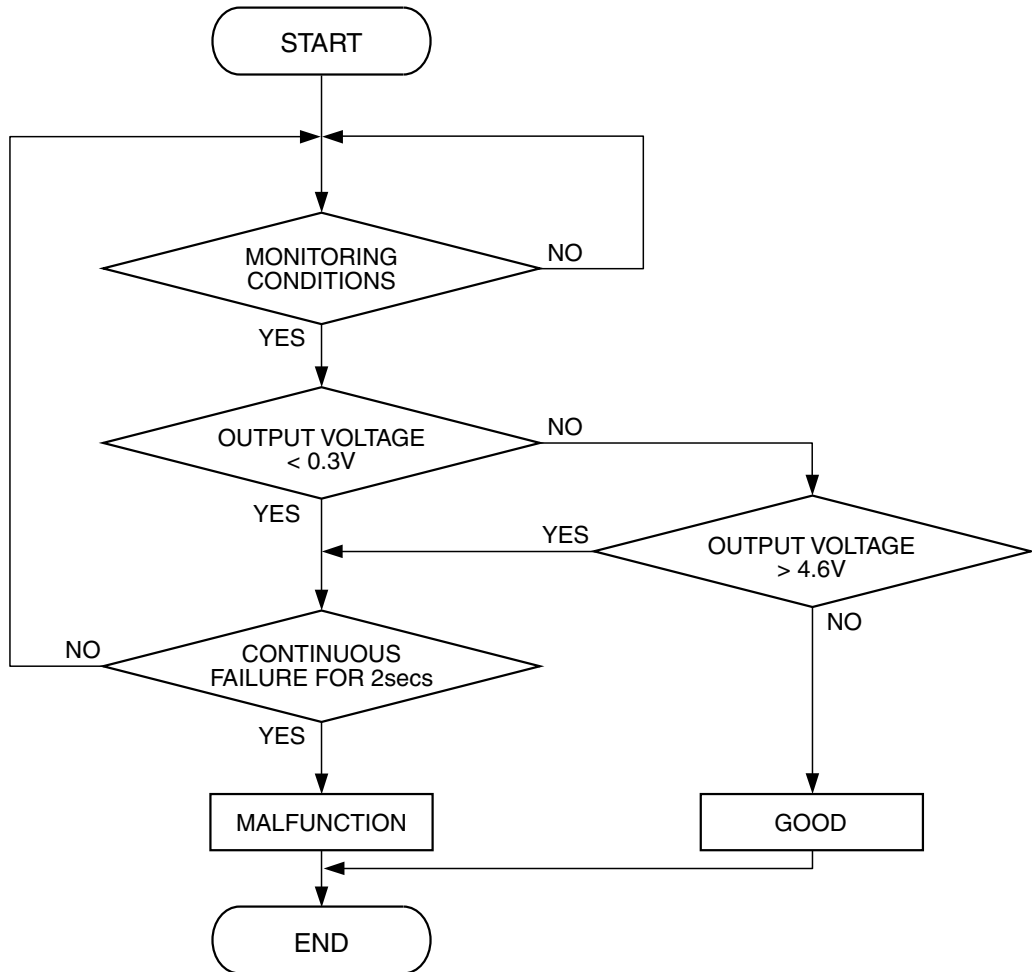

AK401534

Check Conditions

- Battery positive voltage is between 11 and 16.5 volts.
- 2 seconds or more have passed since the engine starting sequence was completed.

Judgement Criterion

- Fuel level sensor output voltage has continued to be lower than 0.3 volt for 2 seconds.

OBD-II DRIVE CYCLE PATTERN

Refer to Diagnostic Function – OBD-II Drive Cycle – Procedure 6 – Other Monitor [P.13A-6](#).

TROUBLESHOOTING HINTS (The most likely causes for this code to be set are:)

- Fuel level sensor failed.
- Shorted fuel level sensor circuit or connector damage.
- PCM failed.

DIAGNOSIS**Required Special Tools:**

- MB991958: Scan Tool (MUT-III Sub Assembly)
 - MB991824: V.C.I.
 - MB991827: USB Cable
 - MB991910: Main Harness A

STEP 1. Check fuel gauge.**Q: Is the fuel gauge functioning?****YES** : Go to Step 2.

NO : Refer to GROUP 54A, Chassis Electrical –
Combination Meters Assembly and Vehicle Speed
Sensor – Equipment Diagnosis – Symptom Chart
[P.54A-16](#).

STEP 2. Check harness connector B-20 at PCM and harness connector D-17 at fuel level sensor (sub) for damage.**Q: Is the harness connector in good condition?****YES** : Go to Step 3.

NO : Repair or replace them. Refer to GROUP 00E,
Harness Connector Inspection [P.00E-2](#) Then go to
Step 7.

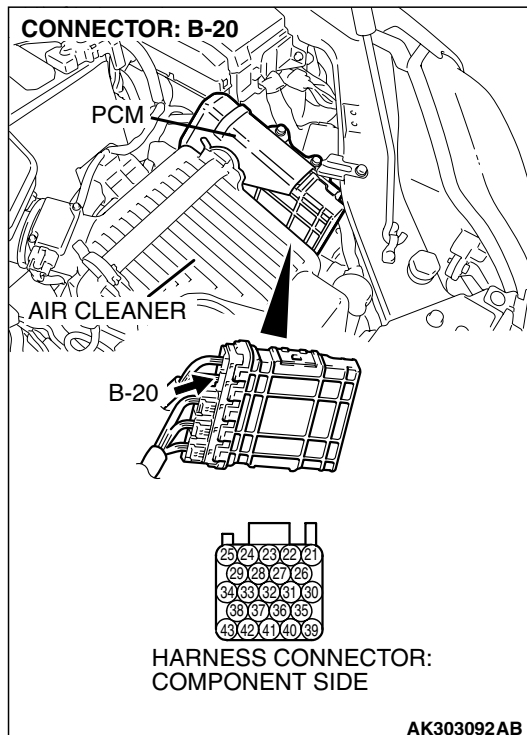
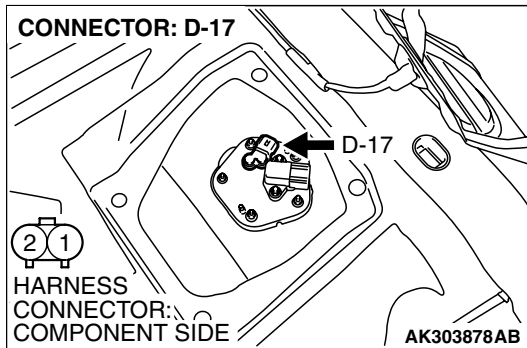

STEP 3. Check for short circuit to ground between PCM connector B-20 (terminal No. 24) and fuel level sensor (sub) connector D-17 (terminal No. 1).

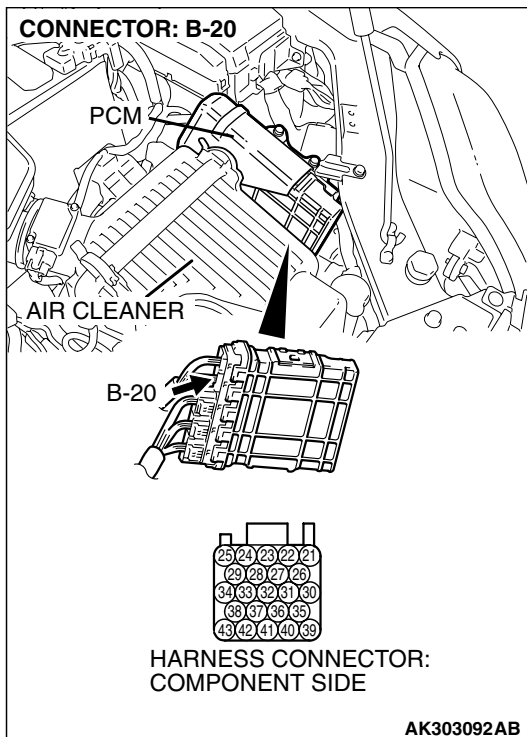
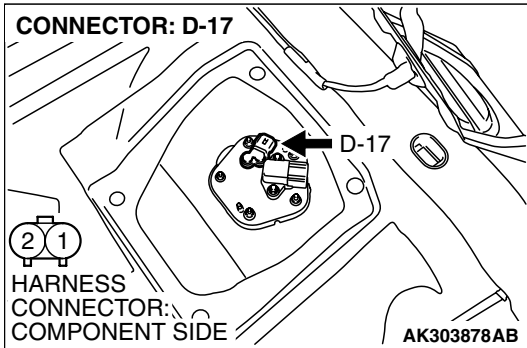

NOTE: Check harness after checking intermediate connectors C-25. If intermediate connectors are damaged, repair or replace them. Refer to GROUP 00E, Harness Connector Inspection P.00E-2. Then go to Step 7.

Q: Is the harness wire in good condition?

YES : Go to Step 4.

NO : Repair it. Then go to Step 7.

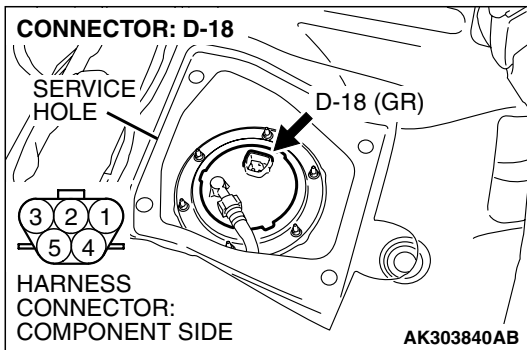

STEP 4. Check harness connector D-18 at fuel level sensor (main) for damage.

Q: Is the harness connector in good condition?

YES : Go to Step 5.

NO : Repair or replace it. Refer to GROUP 00E, Harness Connector Inspection [P.00E-2](#) Then go to Step 7.

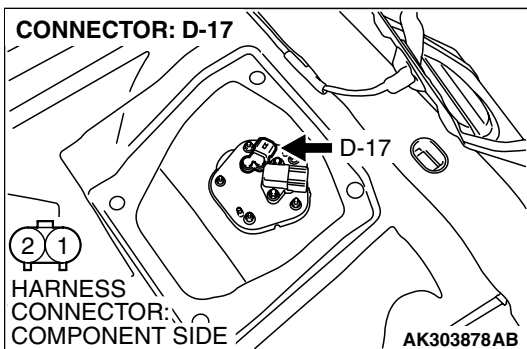

STEP 5. Check for short circuit to ground between fuel level sensor (main) connector D-18 (terminal No. 2) and fuel level sensor (sub) connector D-17 (terminal No. 1).

Q: Is the harness wire in good condition?

YES : Go to Step 6.

NO : Repair it. Then go to Step 7.

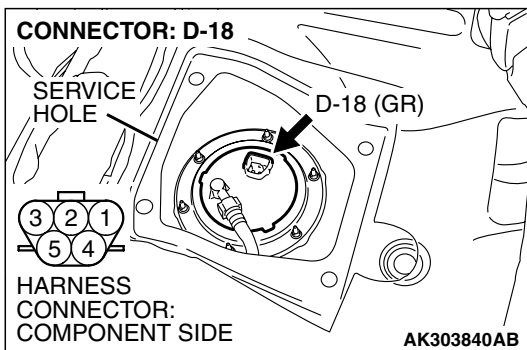

STEP 6. Check the trouble symptoms.

- (1) Carry out a test drive with the drive cycle pattern. Refer to Diagnostic Function – OBD-II Drive Cycle – Procedure 6 – Other Monitor [P.13A-6](#).
- (2) Check the diagnostic trouble code (DTC).

Q: Is DTC P0461 set?

YES : Replace the PCM. Then go to Step 7.

NO : It can be assumed that this malfunction is intermittent. Refer to GROUP 00, How to Use Troubleshooting/Inspection Service Points – How to Cope with Intermittent Malfunctions [P.00-14](#).

STEP 7. Test the OBD-II drive cycle.

- (1) Carry out a test drive with the drive cycle pattern. Refer to Diagnostic Function – OBD-II Drive Cycle – Procedure 6 – Other Monitor [P.13A-6](#).
- (2) Check the diagnostic trouble code (DTC).

Q: Is DTC P0462 set?

- YES** : Retry the troubleshooting.
NO : The inspection is complete.

DTC P0463: Fuel Level Sensor Circuit High Input

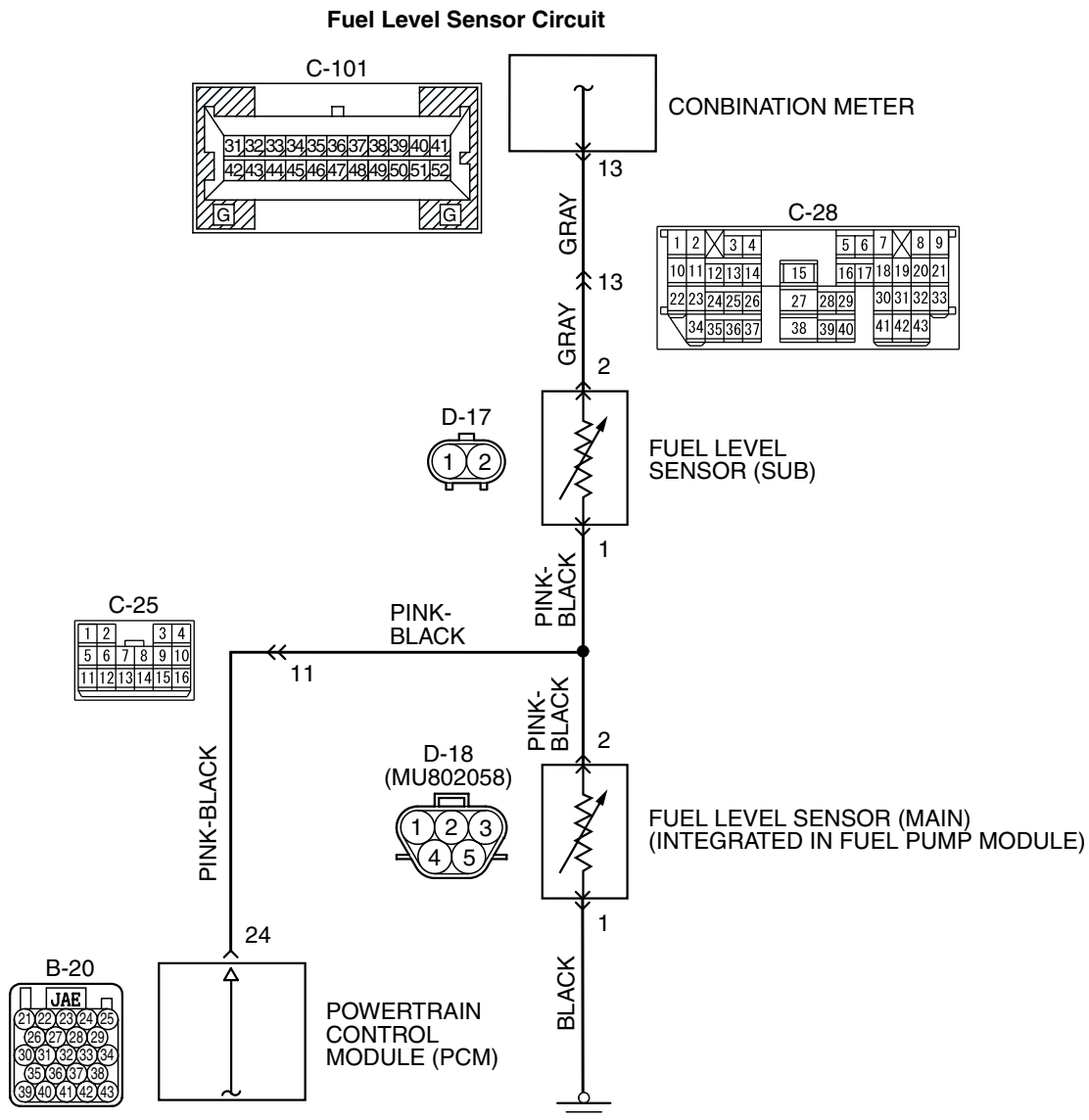

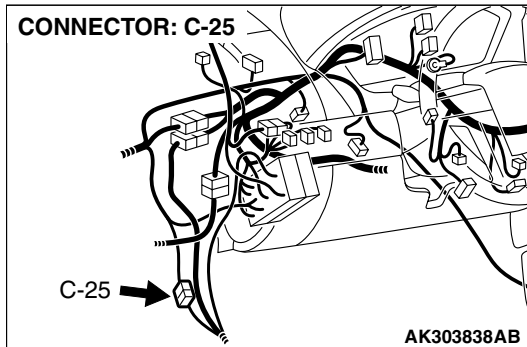
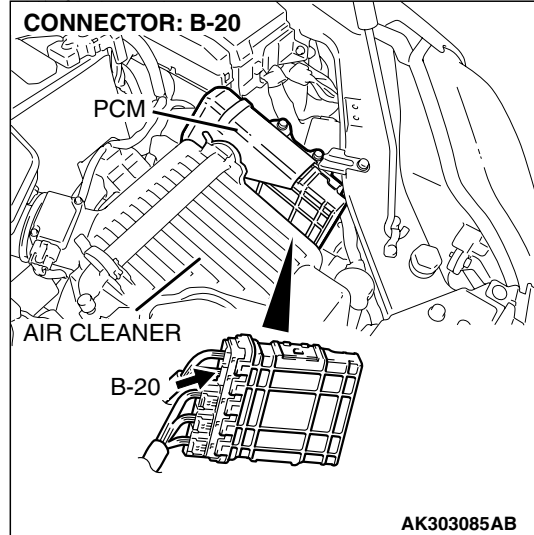
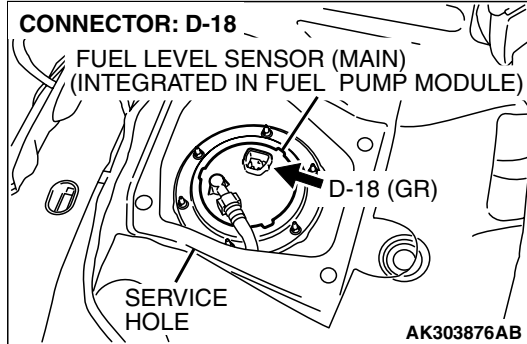
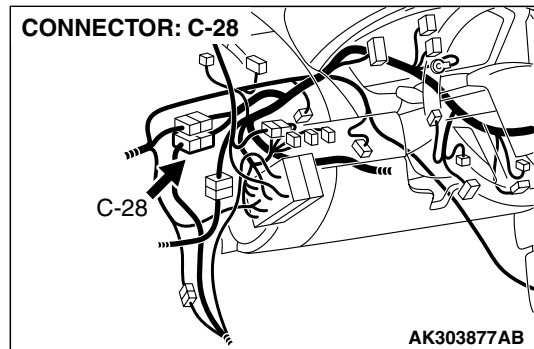
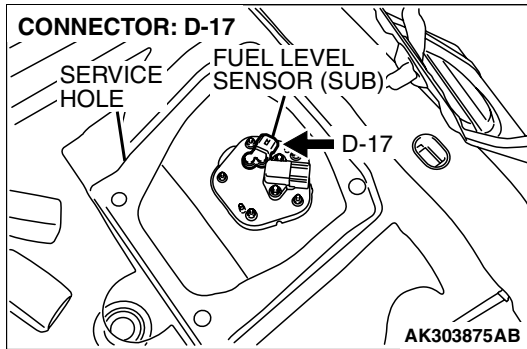

CIRCUIT OPERATION

- The fuel level sensor output voltage is input in combination meter (terminal No. 13).

TECHNICAL DESCRIPTION

- The fuel level sensor converts the rest of the fuel to a voltage.
- The combination meter sends the data regarding the rest of the fuel to the PCM.
- The PCM checks whether this data is within a specified range.

DESCRIPTIONS OF MONITOR METHODS

An open circuit is detected while monitoring the intake air temperature sensor output.

MONITOR EXECUTION

Continuous

**MONITOR EXECUTION CONDITIONS
(Other monitor and Sensor)**

Other Monitor (There is no temporary DTC stored in memory for the item monitored below)

- Not applicable

Sensor (The sensor below is determined to be normal)

- Not applicable

DTC SET CONDITIONS

Logic Flow Chart

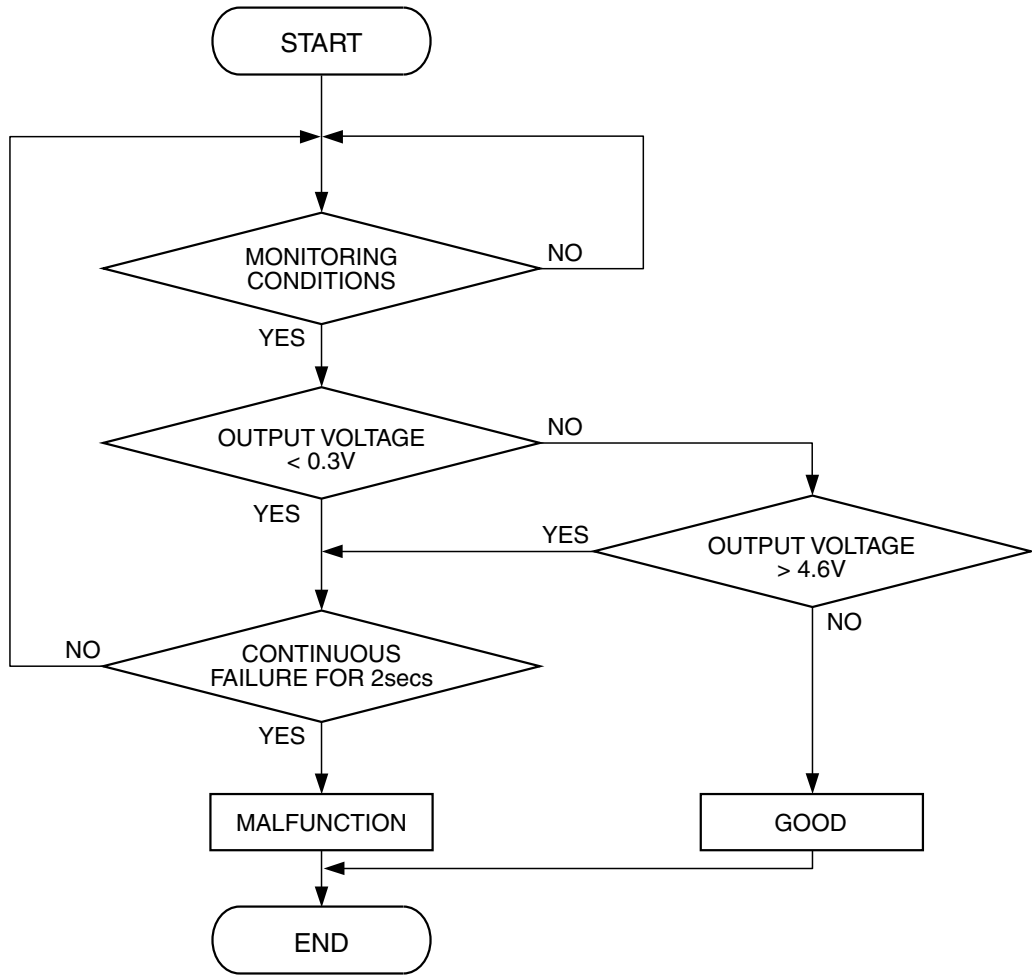

AK401534

Check Conditions

- Battery positive voltage is between 11 and 16.5 volts.
- 2 seconds or more have passed since the engine starting sequence was completed.

Judgement Criterion

- Fuel level sensor output voltage has continued to be higher than 4.6 volts for 2 seconds.

OBD-II DRIVE CYCLE PATTERN

Refer to Diagnostic Function – OBD-II Drive Cycle – Procedure 6 – Other Monitor [P.13A-6](#).

TROUBLESHOOTING HINTS (The most likely causes for this code to be set are:)

- Fuel level sensor failed.
- Open or shorted fuel level sensor circuit, or connector damage.
- PCM failed.

DIAGNOSIS**Required Special Tools:**

- MB991958: Scan tool (MUT-III Sub Assembly)
 - MB991824: V.C.I.
 - MB991827: USB Cable
 - MB991910: Main Harness A

STEP 1. Check fuel gauge.**Q: Is the fuel gauge functioning?****YES** : Go to Step 2.

NO : Refer to GROUP 54A, Chassis Electrical –
Combination Meters Assembly and Vehicle Speed
Sensor – Equipment Diagnosis – Symptom Chart
[P.54A-16](#).

STEP 2. Check harness connector B-20 at PCM and harness connector D-17 at fuel level sensor (sub) for damage.**Q: Is the harness connector in good condition?****YES** : Go to Step 3.

NO : Repair or replace them. Refer to GROUP 00E,
Harness Connector Inspection [P.00E-2](#) Then go to
Step 7.

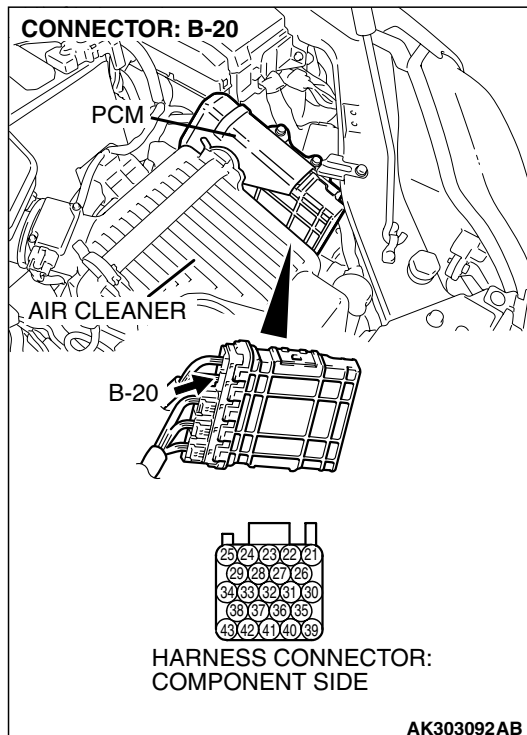
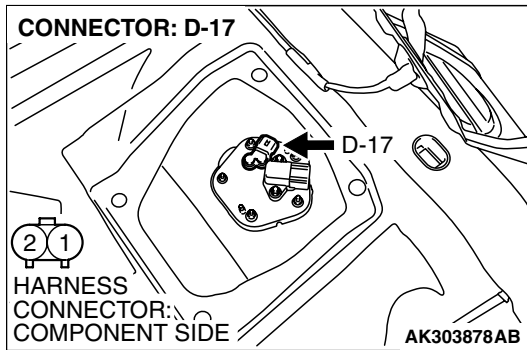

STEP 3. Check for short circuit to ground between PCM connector B-20 (terminal No. 24) and fuel level sensor (sub) connector D-17 (terminal No. 1).

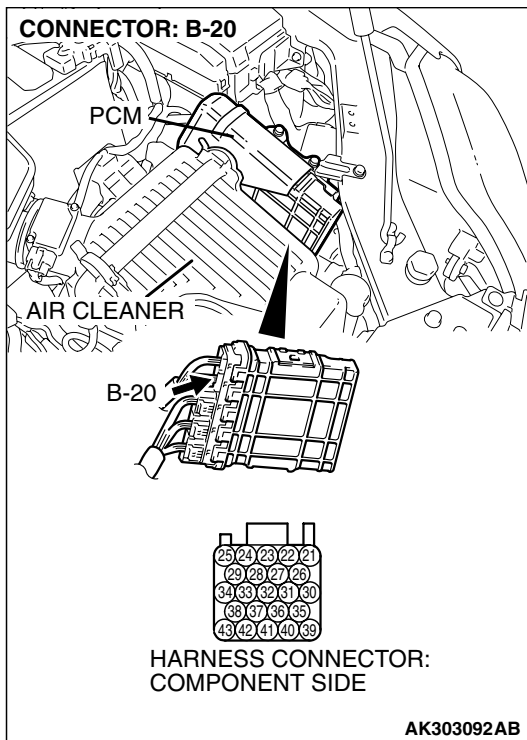
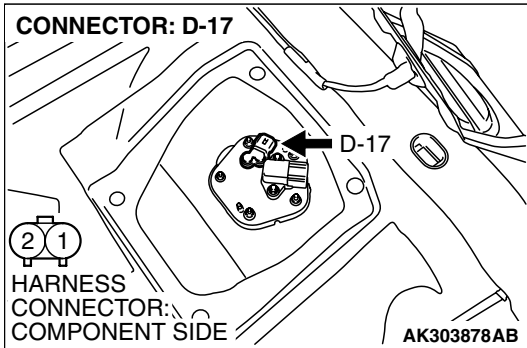

NOTE: Check harness after checking intermediate connector C-25. If intermediate connector is damaged, repair or replace it. Refer to GROUP 00E, Harness Connector Inspection P. 00E-2. Then go to Step 7.

Q: Is the harness wire in good condition?

YES : Go to Step 4.

NO : Repair it. Then go to Step 7.

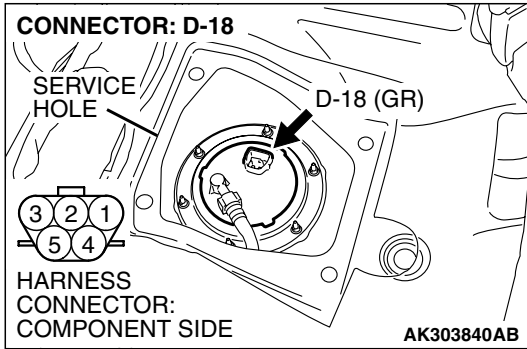

STEP 4. Check harness connector D-18 at fuel level sensor (main) for damage.

Q: Is the harness connector in good condition?

YES : Go to Step 5.

NO : Repair or replace them. Refer to GROUP 00E, Harness Connector Inspection [P.00E-2](#) Then go to Step 7.

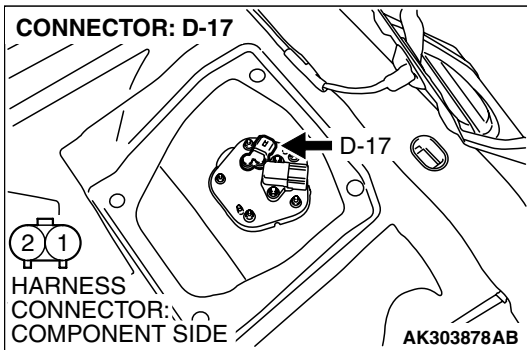

STEP 5. Check for open circuit and short circuit to ground between fuel level sensor (main) connector D-18 (terminal No. 2) and fuel level sensor (sub) connector D-17 (terminal No. 1).

Q: Is the harness wire in good condition?

YES : Go to Step 6.

NO : Repair it. Then go to Step 7.

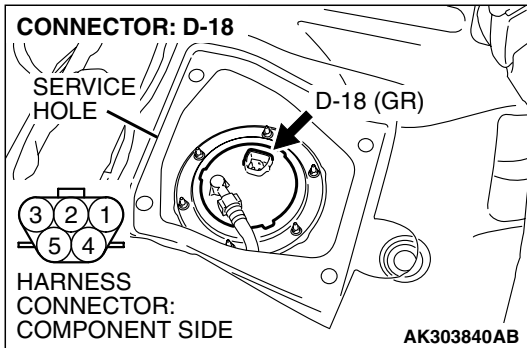

STEP 6. Check the trouble symptoms.

(1) Carry out a test drive with the drive cycle pattern. Refer to Diagnostic Function – OBD-II Drive Cycle – Procedure 6 – Other Monitor [P.13A-6](#).

(2) Check the diagnostic trouble code (DTC).

Q: Is DTC P0463 set?

YES : Replace the PCM. Then go to Step 7.

NO : It can be assumed that this malfunction is intermittent. Refer to GROUP 00, How to Use Troubleshooting/Inspection Service Points – How to Cope with Intermittent Malfunctions [P.00-14](#).

STEP 7. Test the OBD-II drive cycle.

- (1) Carry out a test drive with the drive cycle pattern. Refer to Diagnostic Function – OBD-II Drive Cycle – Procedure 6 – Other Monitor [P.13A-6](#).
- (2) Check the diagnostic trouble code (DTC).

Q: Is DTC P0463 set?

- YES** : Retry the troubleshooting.
NO : The inspection is complete.

DTC P0506: Idle Control System RPM Lower Than Expected

⚠ CAUTION

If DTC P0506 has been set, TCL related DTC U1120 is also set. After P0506 has been diagnosed, don't forget to erase DTC U1120.

TECHNICAL DESCRIPTION

- The amount of air taken in during idling is regulated by the opening and closing of the throttle valve.
- The PCM checks the difference between the actual engine speed and the target engine speed.

DESCRIPTIONS OF MONITOR METHODS

Difference between actual and target idle speed is over the specified value.

MONITOR EXECUTION

Continuous

**MONITOR EXECUTION CONDITIONS
(Other monitor and Sensor)**

Other Monitor (There is no temporary DTC stored in memory for the item monitored below)

- Misfire monitor
- Exhaust gas recirculation (EGR) system monitor
- Fuel system monitor

Sensor (The sensor below is determined to be normal)

- Mass airflow sensor
- Engine coolant temperature sensor
- Intake air temperature sensor
- Barometric pressure sensor
- Throttle position sensor

DTC SET CONDITIONS

Logic Flow Chart

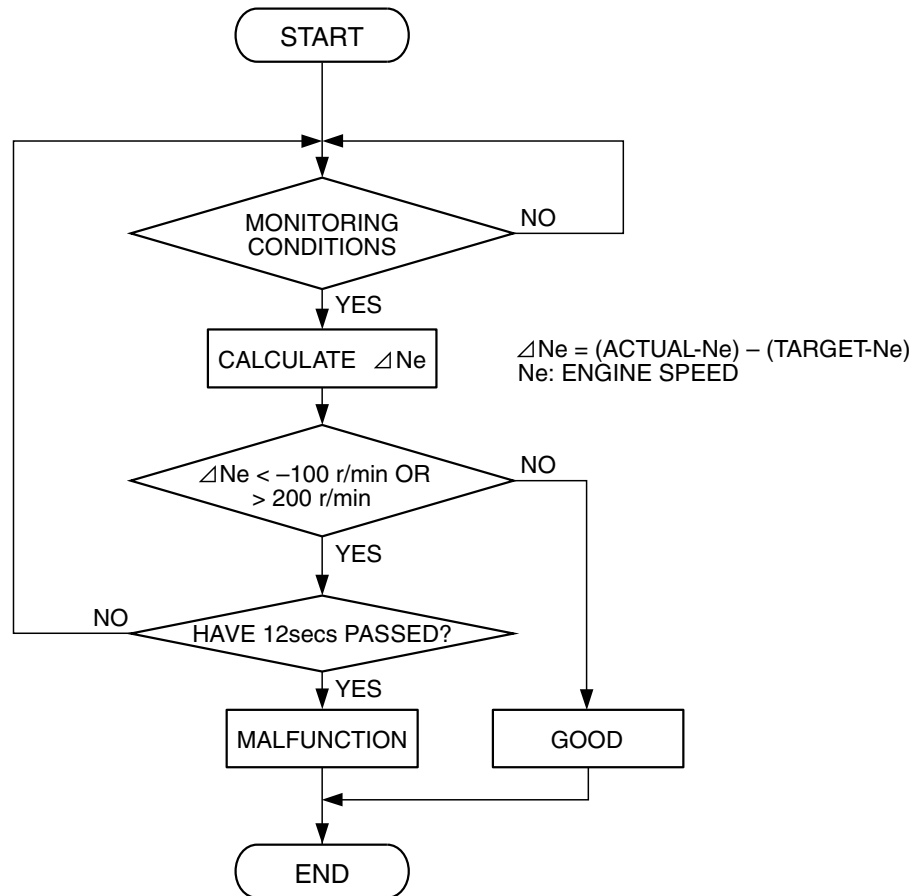

AK302165

Check Conditions

- Under the closed loop idle speed control.
- The engine coolant temperature is more than 77°C (171°F).
- Battery positive voltage is higher than 10 volts.
- Power steering pressure switch: OFF
- Volumetric efficiency is lower than 40 percent.
- Barometric pressure is higher than 76 kPa (22.4 in.Hg).
- Intake air temperature is higher than -10°C (14°F).
- 25 seconds have elapsed from the start of the previous monitoring.

- Target throttle actuator control motor position is more than 255 steps.

Judgment Criteria

- The actual idle speed is more than 100 r/min lower than the target idle speed for 12 seconds.

OBD-II DRIVE CYCLE PATTERN

Refer to Diagnostic Function – OBD-II Drive Cycle – Procedure 6 – Other Monitor [P.13A-6](#).

TROUBLESHOOTING HINTS (The most likely causes for this code to be set are:)

- Throttle valve area is dirty.
- PCM failed.

DIAGNOSIS

Required Special Tools

- MB991958: Scan tool (MUT-III Sub Assembly)
 - MB991824: V.C.I.
 - MB991827: USB Cable
 - MB991910: Main Harness A

STEP 1. Using scan tool MB991958, read the diagnostic trouble code (DTC).

⚠ CAUTION

To prevent damage to scan tool MB991958, always turn the ignition switch to the "LOCK" (OFF) position before connecting or disconnecting scan tool MB991958.

- (1) Connect scan tool MB991958 to the data link connector.
- (2) Turn the ignition switch to the "ON" position.
- (3) Set scan tool MB991958, read the DTC.
- (4) Turn the ignition switch to the "LOCK" (OFF) position.

Q: Is the diagnostic trouble code other than P0506 set?

- YES** : Refer to Diagnostic Trouble Code Chart [P. 13A-33](#).
NO : Go to Step 2.

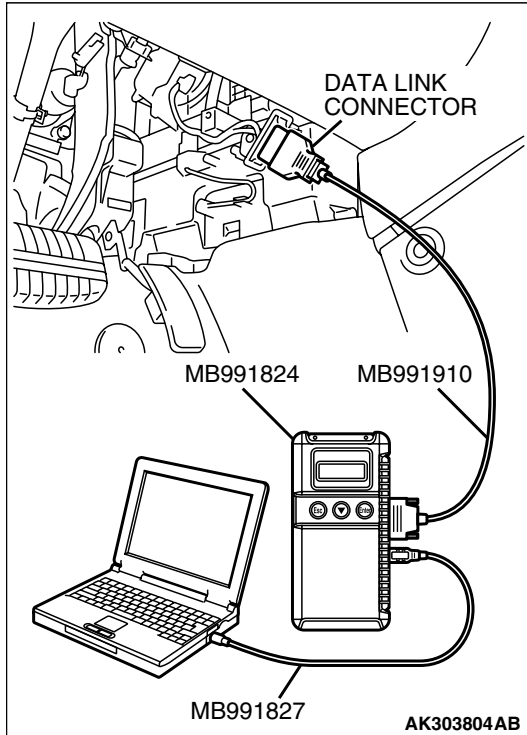

STEP 2. Check the throttle body. (throttle valve area)

Q: Is the throttle valve area dirty?

- YES** : Perform cleaning. Refer to Throttle body (throttle valve area) cleaning [P. 13A-1124](#). Then go to Step 4.
NO : Go to Step 3.

STEP 3. Replace the throttle body assembly.

- (1) Replace the throttle body assembly
- (2) Turn the ignition switch to the "ON" position.
- (3) After the DTC has been deleted, read the DTC again.
- (4) Turn the ignition switch to the "LOCK" (OFF) position.

Q: Is DTC P0506 set?

- YES** : Replace the PCM. Then go to Step 4.
NO : The inspection is complete.

STEP 4. Test the OBD-II drive cycle.

- (1) Carry out a test drive with the drive cycle pattern. Refer to Diagnostic Function – OBD-II – Procedure 6 – Other Monitor [P. 13A-6](#).
- (2) Check the diagnostic trouble code (DTC).

Q: Is DTC P0506 set?

- YES** : Retry the troubleshooting.
NO : The inspection is complete.

DTC P0507: Idle Control System RPM Higher Than Expected

⚠ CAUTION

If DTC P0507 has been set, TCL related DTC U1120 is also set. After P0507 has been diagnosed, don't forget to erase DTC U1120.

TECHNICAL DESCRIPTION

- The amount of air taken in during idling is regulated by the opening and closing of the throttle valve.
- The PCM checks the difference between the actual engine speed and the target engine speed.

DESCRIPTIONS OF MONITOR METHODS

Difference between actual and target idle speed is over the specified value.

MONITOR EXECUTION

Continuous

**MONITOR EXECUTION CONDITIONS
(Other monitor and Sensor)**

Other Monitor (There is no temporary DTC stored in memory for the item monitored below)

- Misfire monitor
- Exhaust gas recirculation (EGR) system monitor
- Fuel system monitor

Sensor (The sensor below is determined to be normal)

- Mass airflow sensor
- Engine coolant temperature sensor
- Intake air temperature sensor
- Barometric pressure sensor
- Throttle position sensor

DTC SET CONDITIONS

Logic Flow Chart

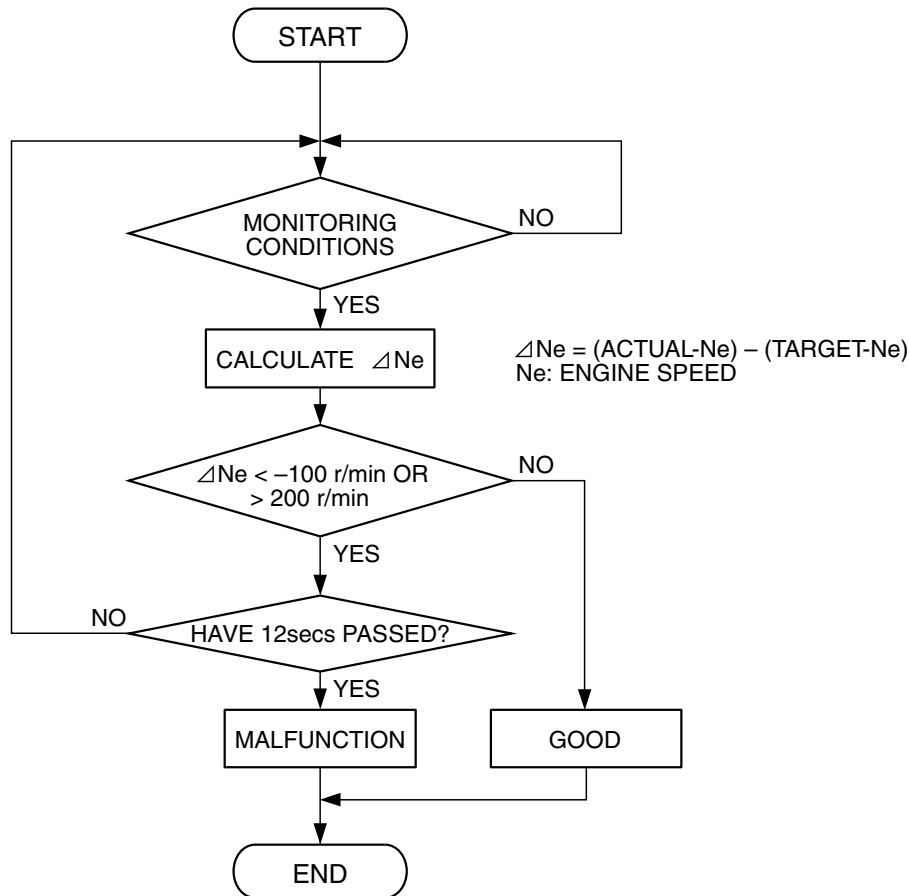

AK302165

Check Conditions

- Vehicle speed has reached 1.5 km/h (1.0 mph) or more at least once.
- Under the closed loop idle speed control.
- Engine coolant temperature is higher than 77°C (171°F).
- Battery positive voltage is higher than 10 volts.
- Barometric pressure is higher than 76 kPa (22.4 in.Hg).
- Intake air temperature is higher than -10°C (14°F).
- 25 seconds have elapsed from the start of the previous monitoring.
- Target throttle actuator control motor position is 0 steps.

Judgment Criteria

- Actual idle speed has continued to be higher than the target idle speed by 200 r/min (300 r/min*) or more for 12 seconds.
- *: Specs in parentheses are applicable if the maximum air temperature during the previous operation was more than 45°C (113°F).

OBD-II DRIVE CYCLE PATTERN

Refer to Diagnostic Function – OBD-II Drive Cycle – Procedure 6 – Other Monitor [P.13A-6](#).

TROUBLESHOOTING HINTS (The most likely causes for this code to be set are:)

- Intake system vacuum leak.
- PCM failed.

DIAGNOSIS**Required Special Tools**

- MB991958: Scan tool (MUT-III Sub Assembly)
 - MB991824: V.C.I.
 - MB991827: USB Cable
 - MB991910: Main Harness A

STEP 1. Using scan tool MB991958, read the diagnostic trouble code (DTC).

⚠ CAUTION

To prevent damage to scan tool MB991958, always turn the ignition switch to the "LOCK" (OFF) position before connecting or disconnecting scan tool MB991958.

- (1) Connect scan tool MB991958 to the data link connector.
- (2) Turn the ignition switch to the "ON" position.
- (3) Set scan tool MB991958, read the DTC.
- (4) Turn the ignition switch to the "LOCK" (OFF) position.

Q: Is the diagnostic trouble code other than P0507 set?

- YES** : Refer to Diagnostic Trouble Code Chart [P. 13A-33](#).
NO : Go to Step 2.

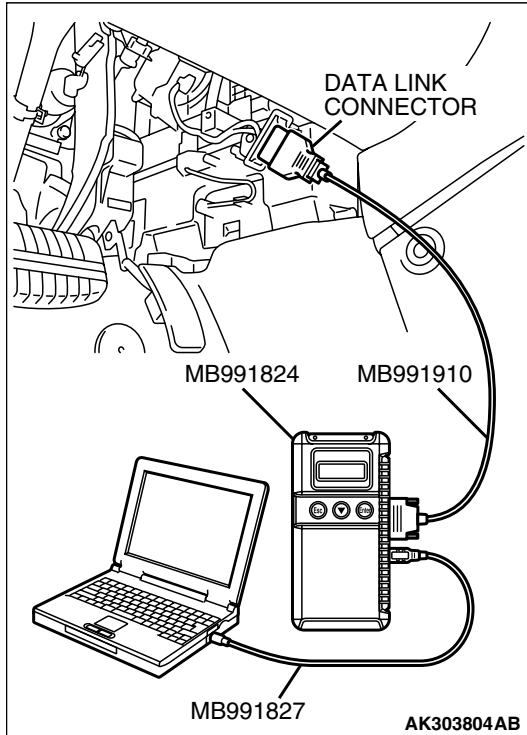

STEP 2. Check the intake system vacuum leak.

Q: Are there any abnormalities?

- YES** : Repair or replace it. Then go to Step 4.
NO : Go to Step 3.

STEP 3. Replace the throttle body assembly.

- (1) Replace the throttle body assembly
- (2) Turn the ignition switch to the "ON" position.
- (3) After the DTC has been deleted, read the DTC again.
- (4) Turn the ignition switch to the "LOCK" (OFF) position.

Q: Is DTC P0507 set?

- YES** : Replace the PCM. Then go to Step 4.
NO : The inspection is complete.

STEP 4. Test the OBD-II drive cycle.

- (1) Carry out a test drive with the drive cycle pattern. Refer to Diagnostic Function – OBD-II Drive Cycle – Procedure 6 – Other Monitor [P.13A-6](#).
- (2) Check the diagnostic trouble code (DTC).

Q: Is DTC P0507 set?

YES : Retry the troubleshooting.

NO : The inspection is complete.

DTC P0513: Immobilizer Malfunction

TECHNICAL DESCRIPTION

- PCM monitors the communication condition with the immobilizer-ECU. When an abnormality in communication is found, PCM prevents engine start.

DTC SET CONDITIONS

Check Conditions

- Ignition switch: ON

Judgment Criteria

- When the communication error between PCM and the immobilizer-ECU continues for 2 seconds or more.

TROUBLESHOOTING HINTS (The most likely causes for this code to be set are:)

- Malfunction of harness or connector.
- Malfunction of immobilizer-ECU.
- Malfunction of PCM.

DIAGNOSIS**Required Special Tools:**

- MB991958: Scan tool (MUT-III Sub Assembly)
 - MB991824: V.C.I.
 - MB991827: USB Cable
 - MB991910: Main Harness A

STEP 1. Using scan tool MB991958, read the immobilizer diagnostic trouble code (DTC).

⚠ CAUTION

To prevent damage to scan tool MB991958, always turn the ignition switch to the "LOCK" (OFF) position before connecting or disconnecting scan tool MB991958.

- (1) Connect scan tool MB991958 to the data link connector.
- (2) Turn the ignition switch to the "ON" position.
- (3) Read the immobilizer-DTC.
- (4) Turn the ignition switch to the "LOCK" (OFF) position.

Q: Is the immobilizer-DTC set?

YES : Refer to GROUP 54A, Ignition Switch and Immobilizer System – Diagnostic Trouble Code Chart [P.54A-12](#).

NO : If DTC P0513 is output again after the MFI-DTC has been erased, replace the PCM. Then check that the DTC P0513 does not reset.

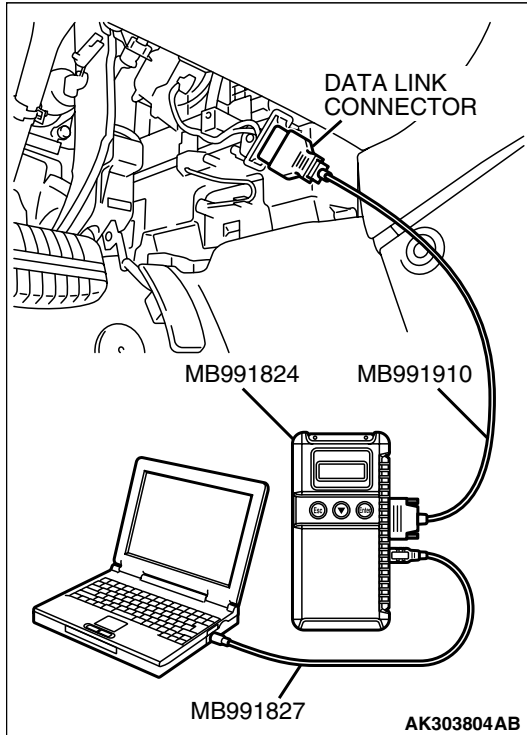

DTC P0551: Power Steering Pressure Switch Circuit Range/Performance

Power Steering Pressure Switch Circuit

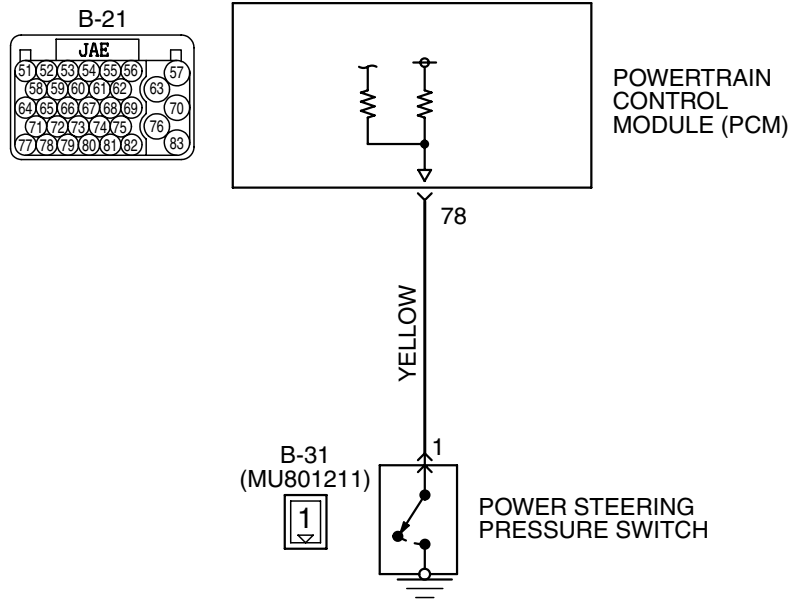

AK303879

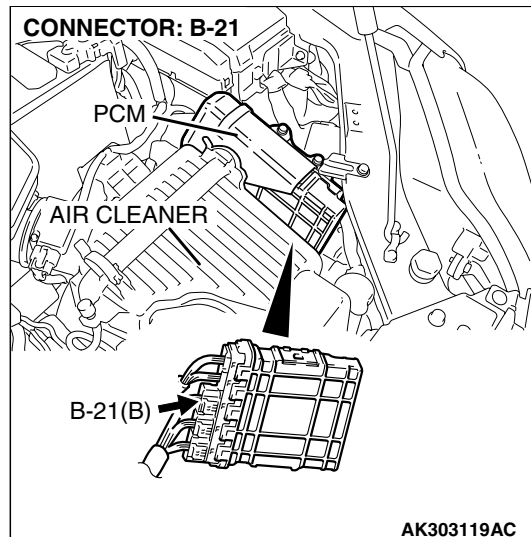
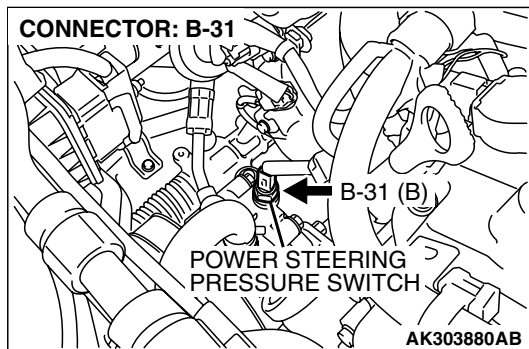

CIRCUIT OPERATION

- A battery positive voltage is applied to the power steering pressure switch output terminal (terminal No. 1) from the PCM (terminal No. 78) via the resistor in the PCM.

TECHNICAL DESCRIPTION

- The power steering pressure switch converts the existence of a power steering load into a high/low voltage, and inputs it into the PCM.

- When the steering wheel is turned, hydraulic pressure rises. The power steering pressure switch closes, and the applied battery positive voltage will be grounded. With this, the power steering pressure switch output voltage will fluctuate between 0 and 12 volts.
- While driving with the steering wheel held straight, the power steering pressure switch turns "OFF".
- The PCM checks whether the power steering pressure switch turns "OFF" or "ON" during driving.

MONITOR EXECUTION

Continuous

**MONITOR EXECUTION CONDITIONS
(Other monitor and Sensor)**

Other Monitor (There is no temporary DTC stored in memory for the item monitored below)

- Not applicable

Sensor (The sensor below is determined to be normal)

- Engine coolant temperature sensor

DESCRIPTIONS OF MONITOR METHODS

Power steering pressure switch stays on during specified go/stop operations.

DTC SET CONDITIONS

Logic Flow Chart

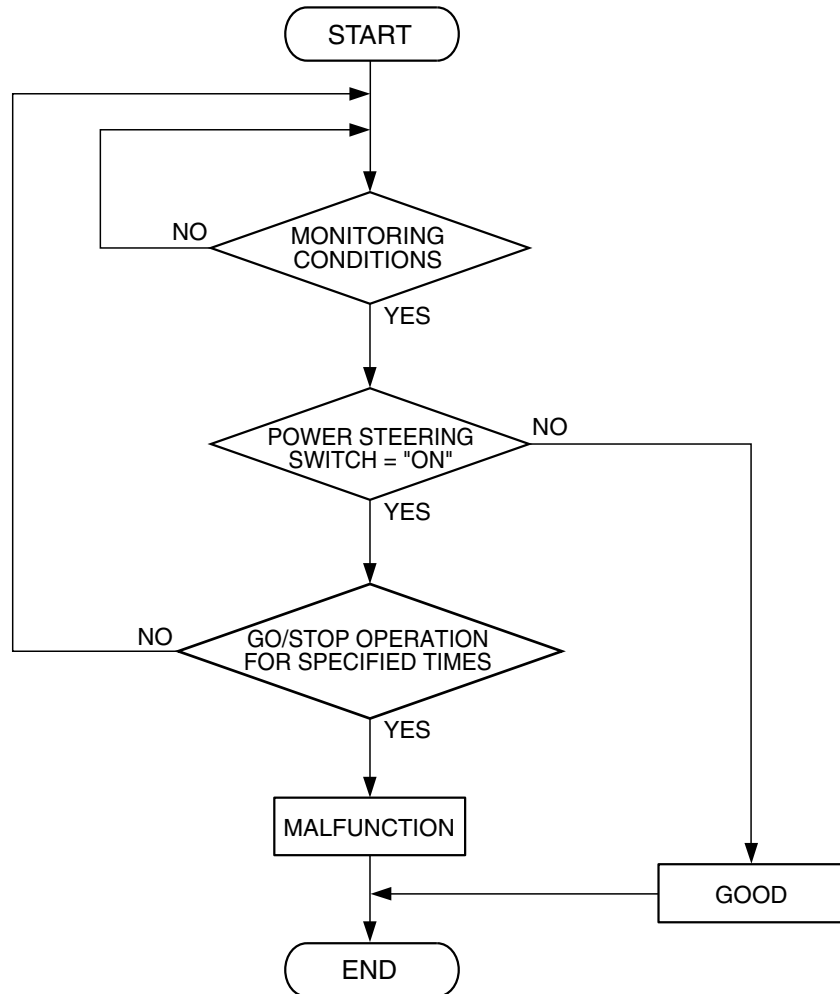

Check Conditions

- Engine coolant temperature is higher than 20°C (68°F).
- Drive for 4 seconds or more with the vehicle speed is 50 km/h (31 mph) or more. Stop the vehicle [vehicle speed is 1.5 km/h (1.0 mph) or less]. Repeat 10 times or more.

Judgment Criteria

- Power steering pressure switch continues to be "ON".

OBD-II DRIVE CYCLE PATTERN

None.

TROUBLESHOOTING HINTS (The most likely causes for this code to be set are:)

- Power steering pressure switch failed.
- Open or shorted power steering pressure switch circuit, harness damage, or connector damage.
- PCM failed.

DIAGNOSIS

Required Special Tools:

- MB991958: Scan tool (MUT-III Sub Assembly)
 - MB991824: V.C.I.
 - MB991827: USB Cable
 - MB991910: Main Harness A

STEP 1. Using scan tool MB991958, check data list item 27: Power Steering Pressure Switch.

⚠ CAUTION

To prevent damage to scan tool MB991958, always turn the ignition switch to the "LOCK" (OFF) position before connecting or disconnecting scan tool MB991958.

- (1) Connect scan tool MB991958 to the data link connector.
- (2) Start the engine and run at idle.
- (3) Set scan tool MB991958 to the data reading mode for item 27, Power Steering Pressure Switch.
 - If the steering wheel is not turned while idling, "OFF" will be displayed.
 - If the steering wheel is turned while idling, "ON" will be displayed.
- (4) Turn the ignition switch to the "LOCK" (OFF) position.

Q: Is the switch operating properly?

YES : It can be assumed that this malfunction is intermittent. Refer to GROUP 00, How to Use Troubleshooting/Inspection Service Points – How to Cope with Intermittent Malfunctions [P.00-14](#).

NO : Go to Step 2.

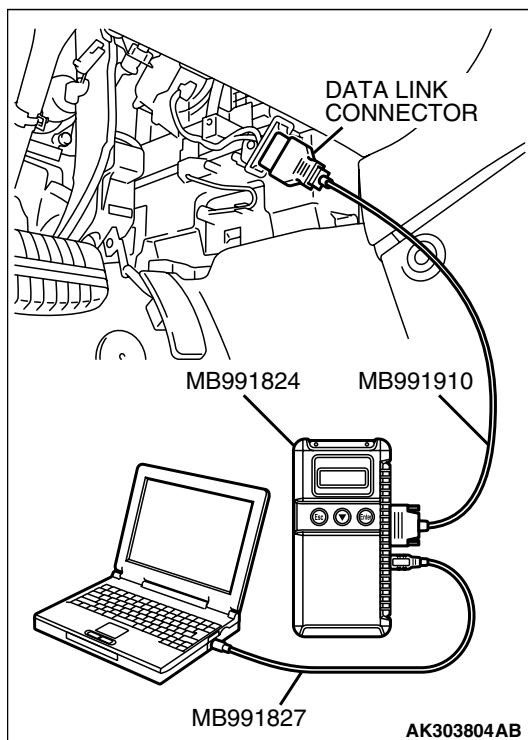

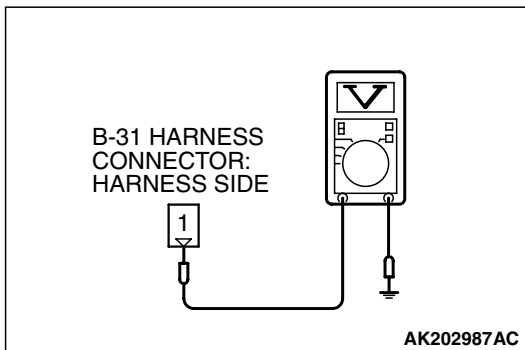
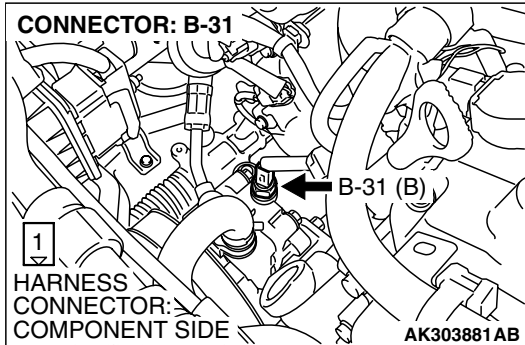

STEP 2. Measure the power supply voltage at power steering pressure switch connector B-31 by backprobing.

- (1) Do not disconnect the connector B-31.
- (2) Start the engine and run at idle.

- (3) Measure the voltage between terminal No. 1 and ground by backprobing.

- When steering wheel is not turned, voltage should be battery positive voltage.
- When steering wheel is turned, voltage should be 1 volt or less.

- (4) Turn the ignition switch to the "LOCK" (OFF) position.

Q: Is the measured voltage within the specified range?

YES : Go to Step 3.

NO : Go to Step 5.

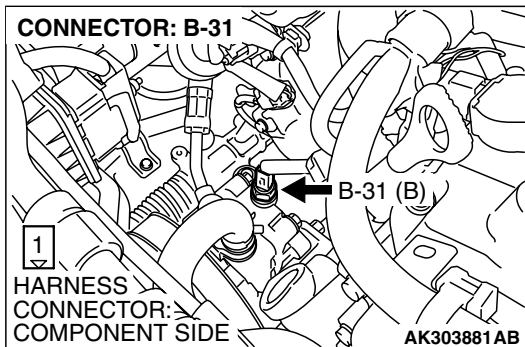

STEP 3. Check harness connector B-31 at power steering pressure switch for damage.

Q: Is the harness connector in good condition?

YES : Go to Step 4.

NO : Repair or replace it. Refer to GROUP 00E, Harness Connector Inspection [P.00E-2](#). Then go to Step 14.

STEP 4. Using scan tool MB991958, check data list item 27: Power Steering Pressure Switch.

⚠ CAUTION

To prevent damage to scan tool MB991958, always turn the ignition switch to the "LOCK" (OFF) position before connecting or disconnecting scan tool MB991958.

- (1) Connect scan tool MB991958 to the data link connector.
- (2) Start the engine and run at idle.
- (3) Set scan tool MB991958 to the data reading mode for item 27, Power Steering Pressure Switch.
 - If the steering wheel is not turned while idling, "OFF" will be displayed.
 - If the steering wheel is turned while idling, "ON" will be displayed.
- (4) Turn the ignition switch to the "LOCK" (OFF) position.

Q: Is the switch operating properly?

YES : It can be assumed that this malfunction is intermittent. Refer to GROUP 00, How to Use Troubleshooting/Inspection Service Points – How to Cope with Intermittent Malfunctions P.00-14.

NO : Replace the PCM. Then go to Step 14.

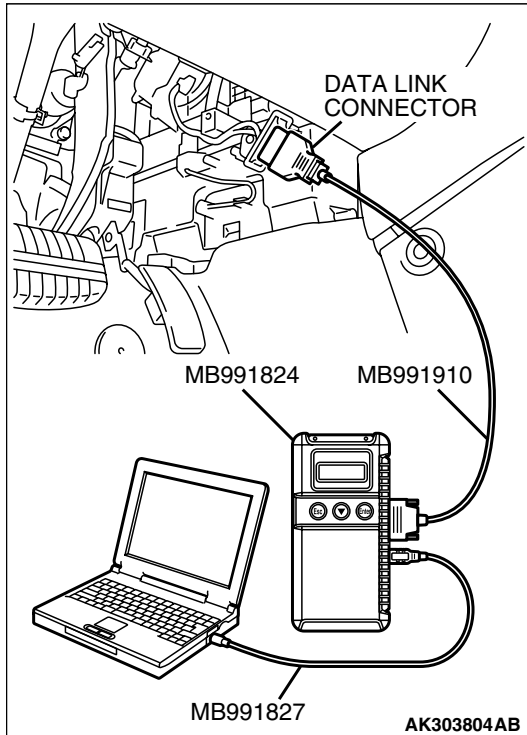

STEP 5. Check harness connector B-31 at power steering pressure switch for damage.

Q: Is the harness connector in good condition?

YES : Go to Step 6.

NO : Repair or replace it. Refer to GROUP 00E, Harness Connector Inspection P.00E-2. Then go to Step 14.

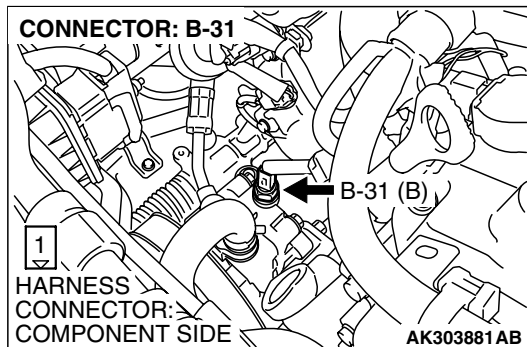

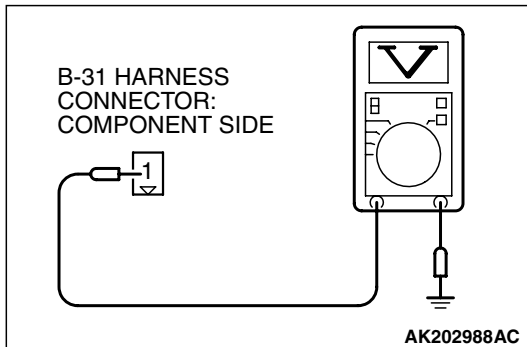
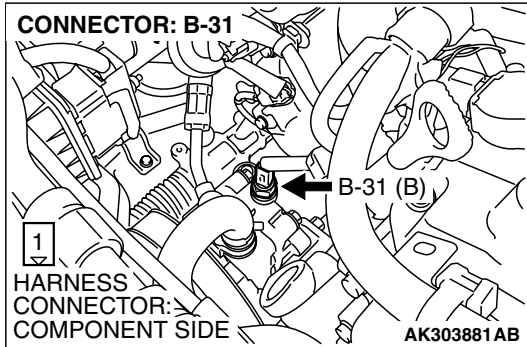

STEP 6. Measure the power supply voltage at power steering pressure switch harness side connector B-31.

- (1) Disconnect the connector B-31 and measure at the harness side.
- (2) Turn the ignition switch to the "ON" position.

- (3) Measure the voltage between terminal No. 1 and ground.
 - Voltage should be battery positive voltage.
- (4) Turn the ignition switch to the "LOCK" (OFF) position.

Q: Is battery positive voltage (approximately 12 volts) present?

- YES** : Go to Step 11.
NO : Go to Step 7.

STEP 7. Measure the power supply voltage at PCM connector B-21 by using power plant ECU check harness special tool MB991923.

- (1) Disconnect the all PCM connectors and connect power plant ECU check harness special tool MB991923 between the separated connectors.
- (2) Disconnect the power steering pressure switch connector B-31.
- (3) Turn the ignition switch to the "ON" position.

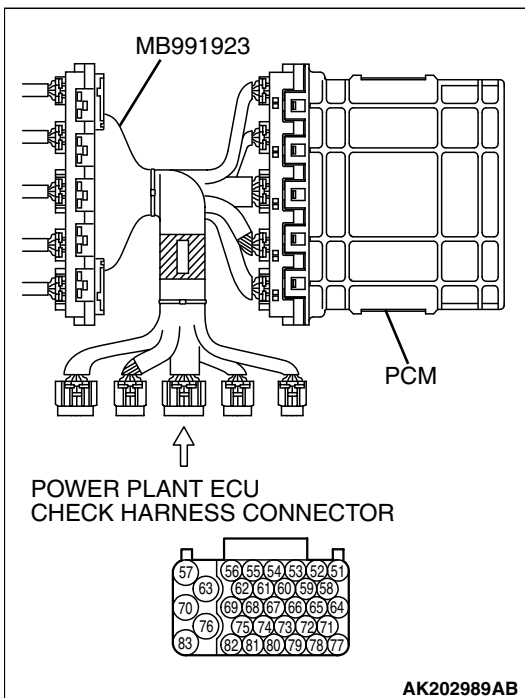
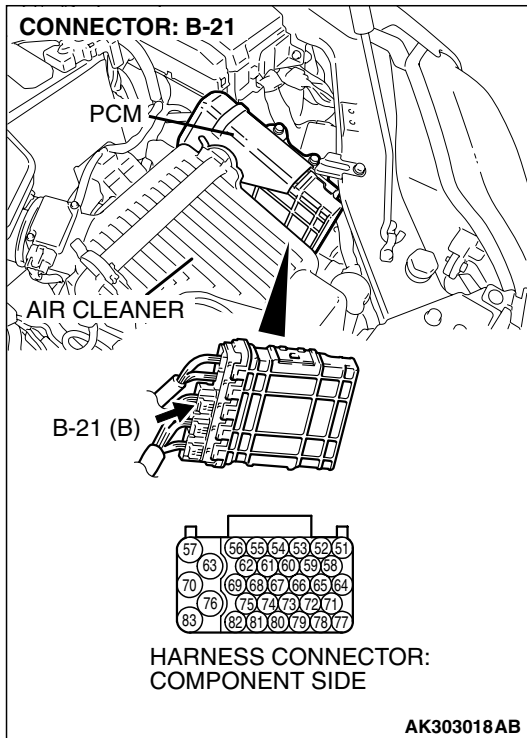

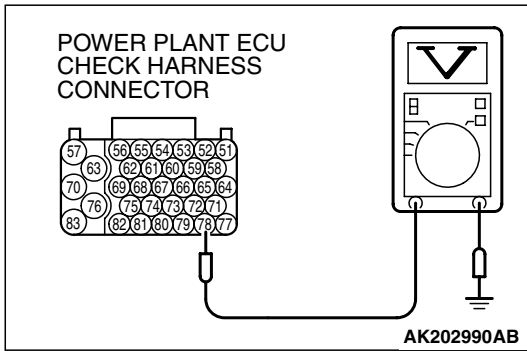

- (4) Measure the voltage between terminal No. 78 and ground.
 • Voltage should be between battery positive voltage.
 (5) Turn the ignition switch to the "LOCK" (OFF) position.

Q: Is battery positive voltage (approximately 12 volts) present?

- YES** : Go to Step 8.
NO : Go to Step 9.

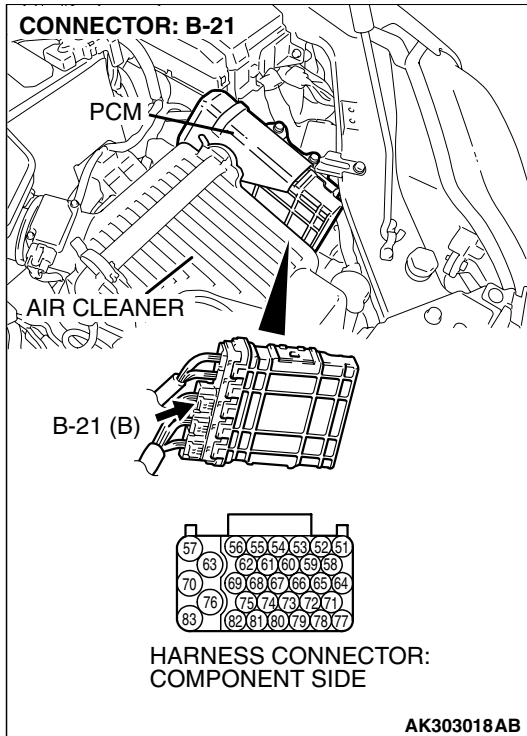

STEP 8. Check harness connector B-21 at PCM for damage.

Q: Is the harness connector in good condition?

- YES** : Repair harness wire between power steering pressure switch connector B-31 (terminal No. 1) and PCM connector B-21 (terminal No. 78) because of open circuit. Then go to Step 14.
NO : Repair or replace it. Refer to GROUP 00E, Harness Connector Inspection [P.00E-2](#). Then go to Step 14.

STEP 9. Check harness connector B-21 at PCM for damage.

Q: Is the harness connector in good condition?

YES : Go to Step 10.

NO : Repair or replace it. Refer to GROUP 00E, Harness Connector Inspection [P.00E-2](#). Then go to Step 14.

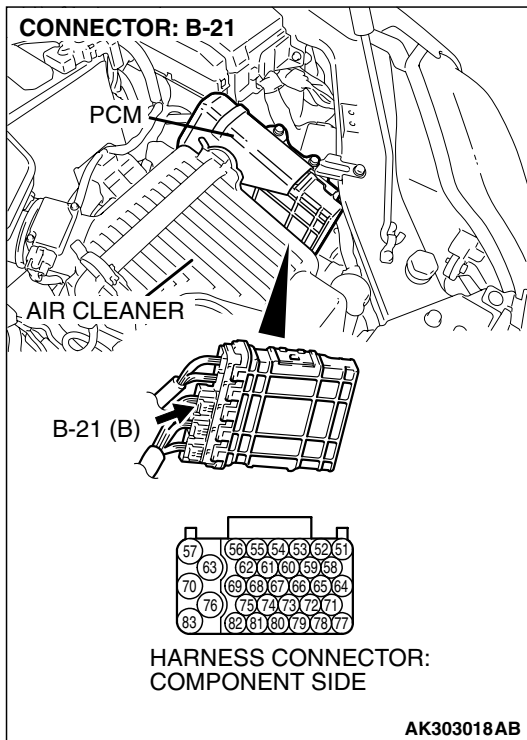

STEP 10. Check for short circuit to ground between power steering pressure switch connector B-31 (terminal No. 1) and PCM connector B-21 (terminal No. 78).

Q: Is the harness wire in good condition?

- YES :** Replace the PCM. Then go to Step 14.
- NO :** Repair it. Then go to Step 14.

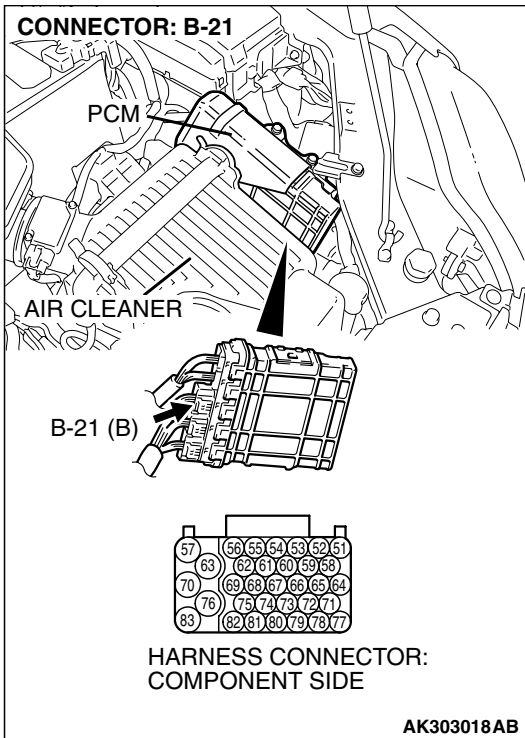
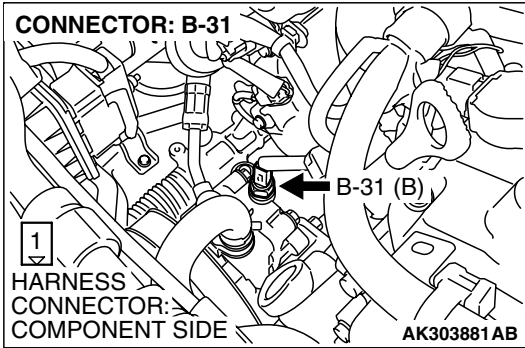

STEP 11. Replace the power steering pressure switch.

- (1) Replace the power steering pressure switch.
- (2) Check the trouble symptoms.
- (3) Read in the diagnostic trouble code (DTC).

Q: Is DTC P0551 set?

- YES :** Go to Step 12.
- NO :** Go to Step 14.

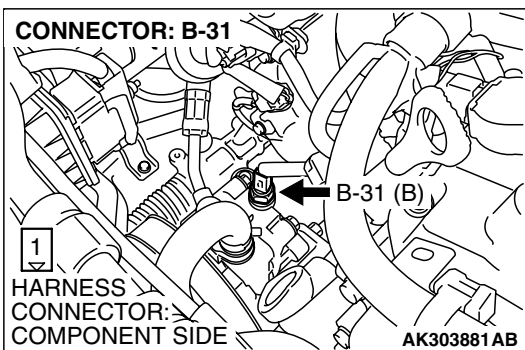

STEP 12. Check harness connector B-21 at PCM for damage.

Q: Is the harness connector in good condition?

YES : Go to Step 13.

NO : Repair or replace it. Refer to GROUP 00E, Harness Connector Inspection [P.00E-2](#). Then go to Step 14.

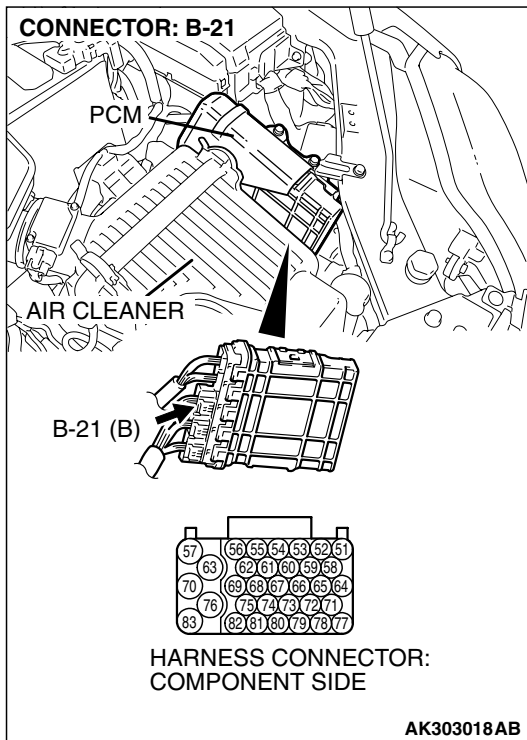

STEP 13. Check for harness damage between power steering pressure switch connector B-31 (terminal No. 1) and PCM connector B-21 (terminal No. 78).

Q: Is the harness wire in good condition?

- YES :** Replace the PCM. Then go to Step 14.
- NO :** Repair it. Then go to Step 14.

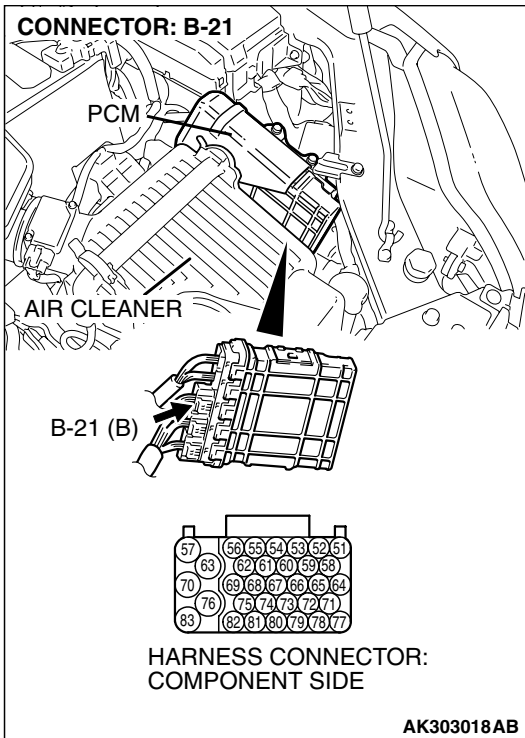
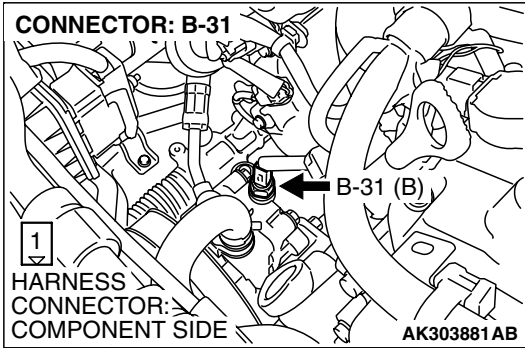

STEP 14. Using scan tool MB991958, check data list item 27: Power Steering Pressure Switch.

⚠ CAUTION

To prevent damage to scan tool MB991958, always turn the ignition switch to the "LOCK" (OFF) position before connecting or disconnecting scan tool MB991958.

- (1) Connect scan tool MB991958 to the data link connector.
- (2) Start the engine and run at idle.
- (3) Set scan tool MB991958 to the data reading mode for item 27, Power Steering Pressure Switch.
 - If the steering wheel is not turned while idling, "OFF" will be displayed.
 - If the steering wheel is turned while idling, "ON" will be displayed.
- (4) Turn the ignition switch to the "LOCK" (OFF) position.

Q: Is the switch operating properly?

YES : The inspection is complete.

NO : Retry the troubleshooting.

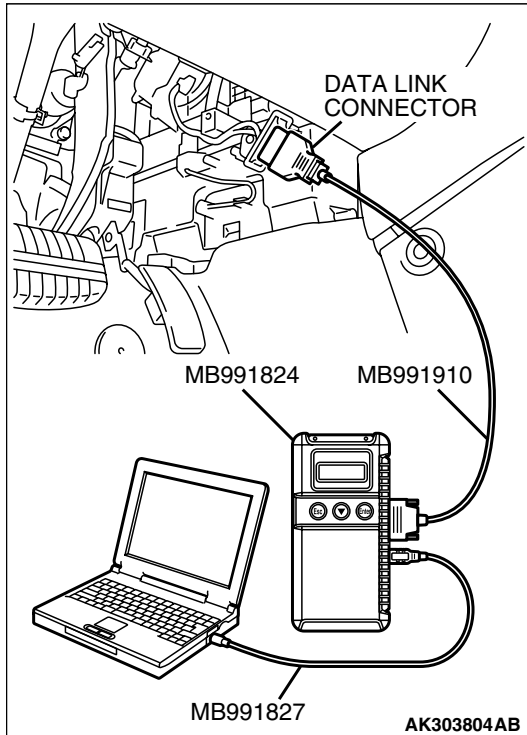

DTC P0554: Power Steering Pressure Switch Circuit Intermittent

Power Steering Pressure Switch Circuit

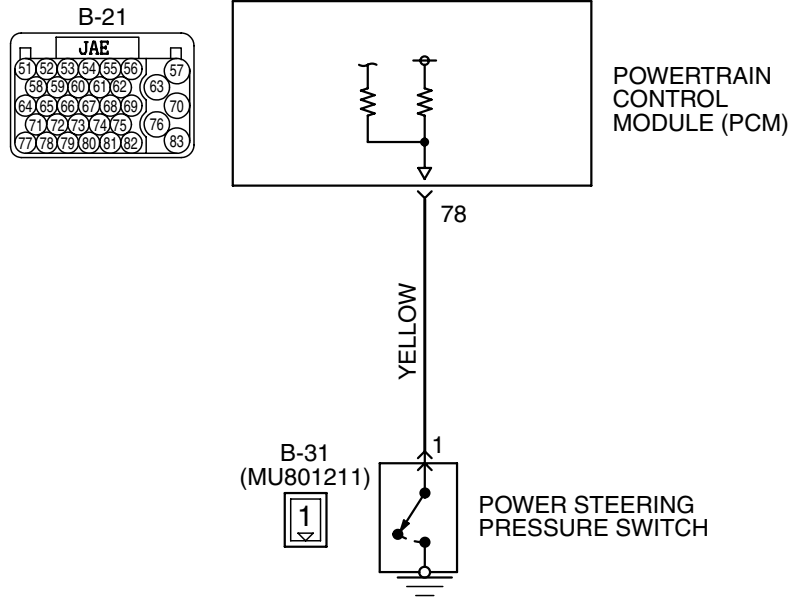

AK303879

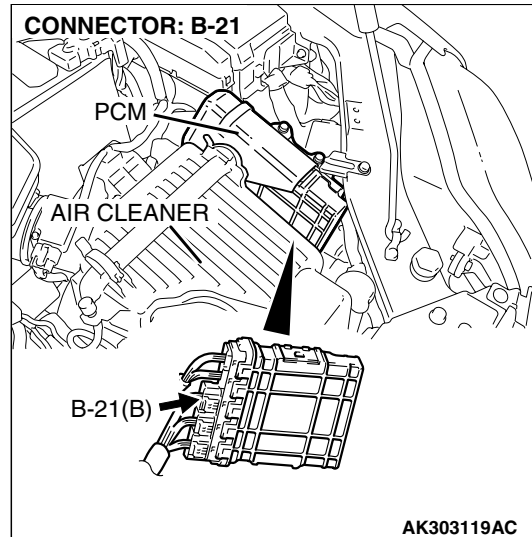
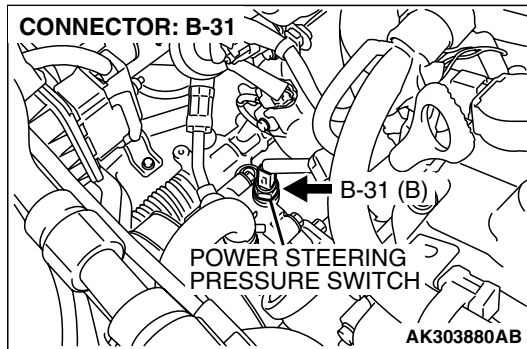

CIRCUIT OPERATION

- A battery positive voltage is applied to the power steering pressure switch output terminal (terminal No. 1) from the PCM (terminal No. 78) via the resistor in the PCM.

TECHNICAL DESCRIPTION

- The power steering pressure switch converts the existence of a power steering load into a high/low voltage, and inputs it into the PCM.

- When the steering wheel is turned, hydraulic pressure rises. The power steering pressure switch closes, and the applied battery positive voltage will be grounded. With this, the power steering pressure switch output voltage will fluctuate between 0 and 12 volts.
- While driving with the steering wheel held straight, the power steering pressure switch turns "OFF".
- The PCM checks whether the power steering pressure switch turns "OFF" or "ON" during driving.

MONITOR EXECUTION

Continuous

MONITOR EXECUTION CONDITIONS (Other monitor and Sensor)

Other Monitor (There is no temporary DTC stored in memory for the item monitored below)

- Not applicable

Sensor (The sensor below is determined to be normal)

- Engine coolant temperature sensor

DESCRIPTIONS OF MONITOR METHODS

Power steering pressure switch changes from off to on more than 10 times for 1 second.

DTC SET CONDITIONS

Logic Flow Chart

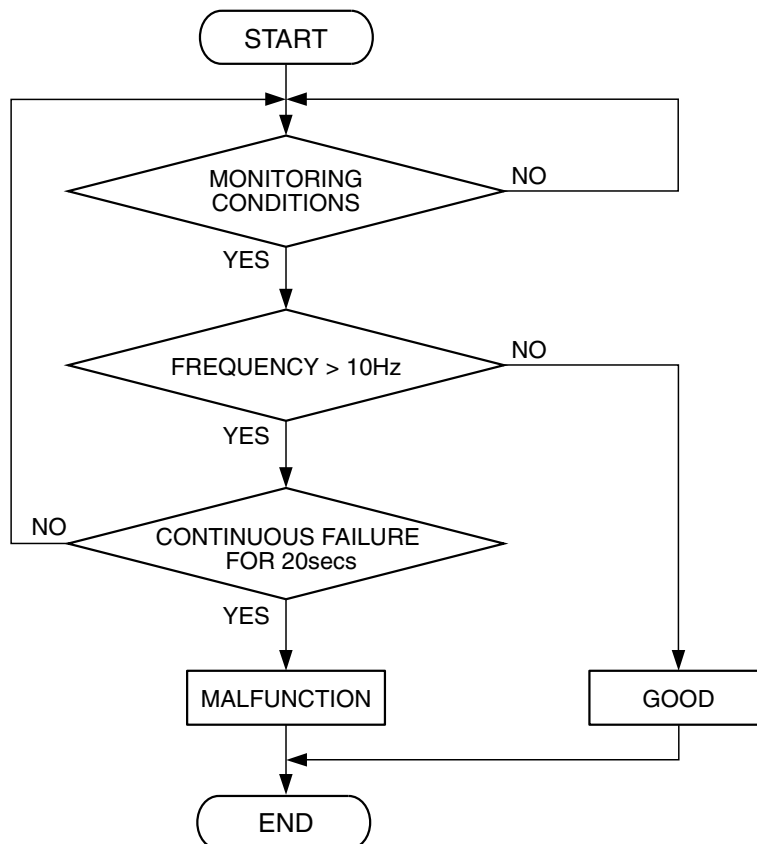

AK302041

Check Conditions

- Engine coolant temperature is higher than 20°C (68°F).
- Vehicle speed is higher than 50 km/h (31 mph).

Judgment Criteria

- The ON/OFF frequency of a power steering pressure switch is 10 Hz or more for 20 seconds.

OBD-II DRIVE CYCLE PATTERN

None.

TROUBLESHOOTING HINTS (The most likely causes for this code to be set are:)

- Power steering pressure switch failed.
- Incorrect power steering fluid level.
- Incorrect oil pump pressure.
- Harness damage in power steering pressure switch circuit, or connector damage.
- PCM failed.

DIAGNOSIS**Required Special Tools:**

- MB991958: Scan tool (MUT-III Sub Assembly)
 - MB991824: V.C.I.
 - MB991827: USB Cable
 - MB991910: Main Harness A

STEP 1. Using scan tool MB991958, check data list item 27: Power Steering Pressure Switch.**⚠ CAUTION**

To prevent damage to scan tool MB991958, always turn the ignition switch to the "LOCK" (OFF) position before connecting or disconnecting scan tool MB991958.

- (1) Connect scan tool MB991958 to the data link connector.
- (2) Start the engine and run at idle.
- (3) Set scan tool MB991958 to the data reading mode for item 27, Power Steering Pressure Switch.
 - If the steering wheel is not turned while idling, "OFF" will be displayed.
 - If the steering wheel is turned while idling, "ON" will be displayed.
- (4) Turn the ignition switch to the "LOCK" (OFF) position.

Q: Is the sensor operating properly?

YES : It can be assumed that this malfunction is intermittent. Refer to GROUP 00, How to Use Troubleshooting/Inspection Service Points – How to Cope with Intermittent Malfunctions [P.00-14](#).

NO : Go to Step 2.

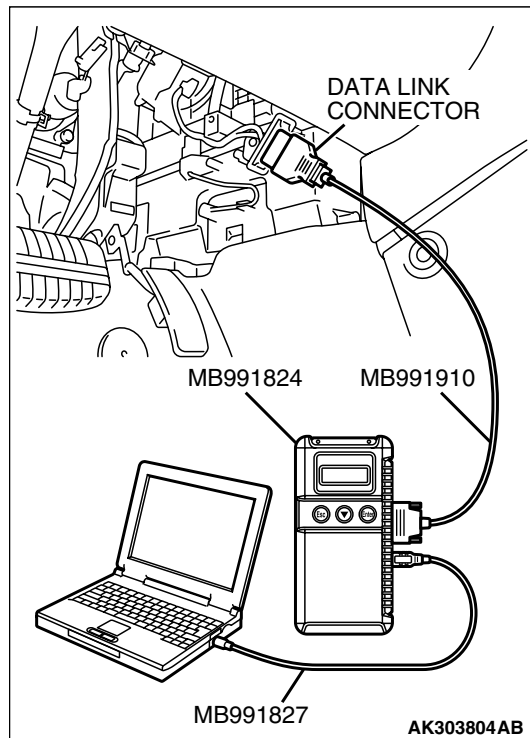
**STEP 2. Check the power steering fluid level.**

Refer to GROUP 37, On-Vehicle Service – Fluid Level Check [P.37-20](#).

Q: Are there any abnormalities?

YES : Repair it. Then go to Step 7.

NO : Go to Step 3.

STEP 3. Check the power steering pressure switch.

Refer to GROUP 37, On-Vehicle Service – Power Steering Pressure Switch Check [P.37-23](#).

Q: Are there any abnormalities?

YES : Replace the power steering pressure switch. Then go to Step 7.

NO : Go to Step 4.

STEP 4. Check the oil pump pressure.

Refer to GROUP 37, On-Vehicle Service – Oil Pump Pressure Test [P.37-22](#).

Q: Are there any abnormalities?

YES : Repair it. Then go to Step 7.

NO : Go to Step 5.

STEP 5. Check harness connector B-31 at the power steering pressure switch and harness connector B-21 at PCM for damage.

Q: Is the harness connector in good condition?

YES : Go to Step 6.

NO : Repair or replace it. Refer to GROUP 00E, Harness Connector Inspection [P.00E-2](#). Then go to Step 7.

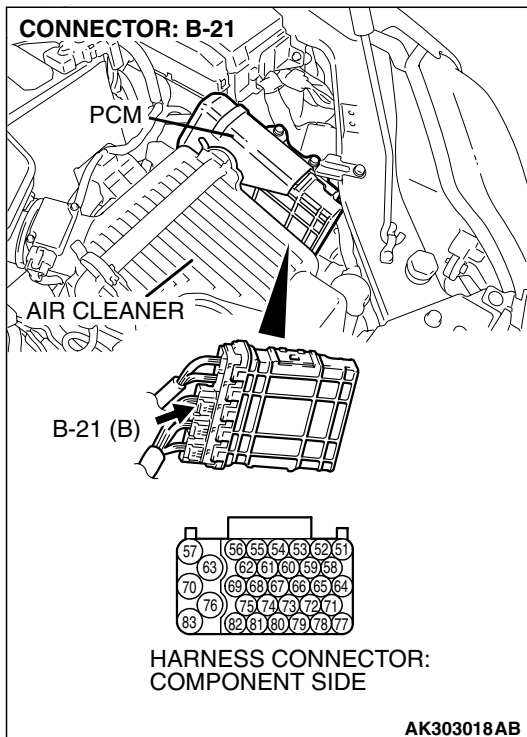
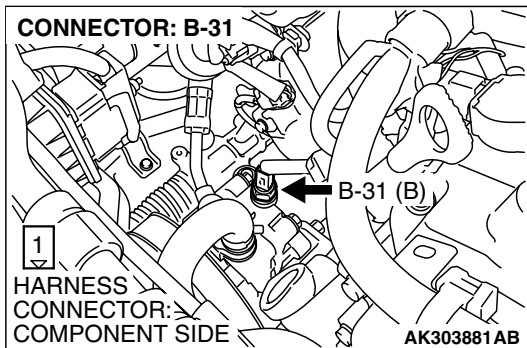

STEP 6. Check for harness damage between power steering pressure switch connector B-31 (terminal No. 1) and PCM connector B-21 (terminal No. 78).

Q: Is the harness wire in good condition?

- YES :** Replace the PCM. Then go to Step 7.
- NO :** Repair it. Then go to Step 7.

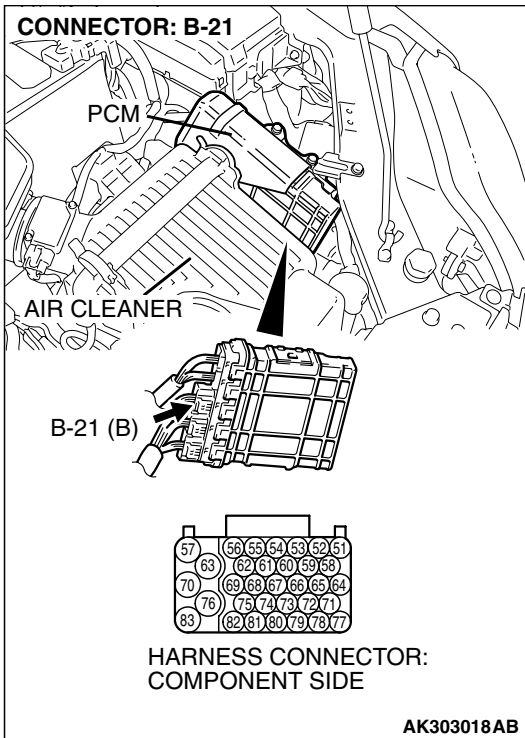
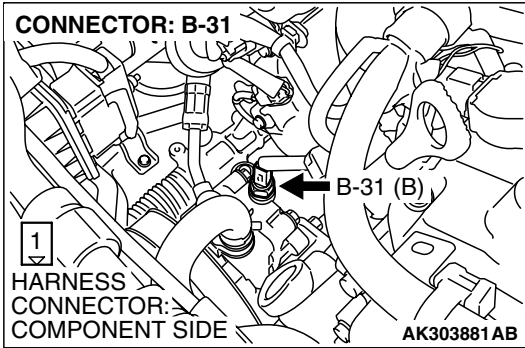

STEP 7. Using scan tool MB991958, check data list item 27: Power Steering Pressure Switch.

⚠ CAUTION

To prevent damage to scan tool MB991958, always turn the ignition switch to the "LOCK" (OFF) position before connecting or disconnecting scan tool MB991958.

- (1) Connect scan tool MB991958 to the data link connector.
- (2) Start the engine and run at idle.
- (3) Set scan tool MB991958 to the data reading mode for item 27, Power Steering Pressure Switch.
 - If the steering wheel is not turned while idling, "OFF" will be displayed.
 - If the steering wheel is turned while idling, "ON" will be displayed.
- (4) Turn the ignition switch to the "LOCK" (OFF) position.

Q: Is the switch operating properly?

YES : The inspection is complete.

NO : Retry the troubleshooting.

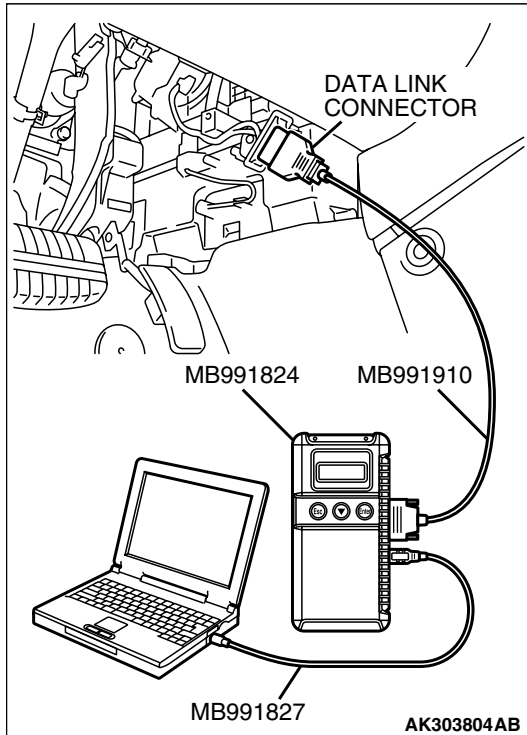

NEXT>>