GROUP 12**ENGINE
LUBRICATION****CONTENTS**

GENERAL DESCRIPTION	12-2	ENGINE OIL FILTER REPLACEMENT	12-4
SPECIAL TOOLS	12-3	ENGINE OIL PRESSURE CHECK	12-6
ON-VEHICLE SERVICE	12-3	SPECIFICATIONS	12-7
ENGINE OIL CHECK	12-3	FASTENER TIGHTENING SPECIFICATIONS	12-7
ENGINE OIL REPLACEMENT	12-3	SERVICE SPECIFICATIONS	12-7
		SEALANT	12-7
		LUBRICANT	12-7

GENERAL DESCRIPTION

M1121000100410

The lubrication method is a fully force-fed, full-flow filtration type.

ITEM		SPECIFICATION
Oil pump type	2.4L Engine	Involute gear type
	3.8L Engine	Trochoid type
Drive method		Crankshaft

ENGINE OILS**⚠ WARNING**

Prolonged and repeated contact with mineral oil will result in the removal of natural fats from the skin, leading to dryness, irritation and dermatitis. In addition, used engine oil contains potentially harmful contaminants which may cause skin cancer. Adequate means of skin protection and washing facilities must be provided.

Recommended Precautions

The most effective precaution is to adapt working practices which prevent, as far as practical, the risk of skin contact with mineral oils i.e. use enclosed systems for handling used engine oil and degrease components, where practical, before handling them.

Other precautions:

- Avoid prolonged and repeated contact with oil, particularly used engine oil.
- Wear protective clothing, including impervious gloves where practical.
- Avoid contaminating clothes with oil.
- Do not put oily rags in pockets.
- Do not wear heavily soiled clothing and oil-soaked foot-wear. Overalls must be cleaned regularly and kept separate from personal clothing.
- Where there is a risk of eye contact, eye protection should be worn i.e. chemical goggles or face shields. In addition, an eye wash facility should be provided.
- Obtain first aid treatment immediately for open cuts and wounds.
- Wash regularly with soap and water to ensure all oil is removed (skin cleansers and nail brushes will help). After cleaning, apply lotion, etc., containing lanolin to replace natural skin oils is advised.
- Do not use gasoline, kerosene, diesel fuel, gas oil, thinners or solvents for cleaning skin.
- Apply barrier creams before each work period.
- If skin disorders develop, obtain medical advice immediately.

SPECIAL TOOLS

M1121000600404

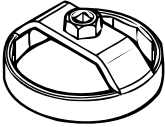
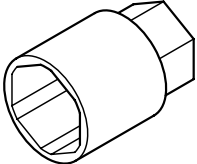
TOOL	TOOL NUMBER AND NAME	SUPERSESSION	APPLICATION
 <p>MB991610</p>	MB991610 Oil filter wrench	General service tool	Removal and installation of engine oil filter (when using oil filter MD356000)
	MD998054 Engine oil pressure switch wrench	General service tool or MD998054-01	Removal and installation of engine oil pressure switch

ON-VEHICLE SERVICE

ENGINE OIL CHECK

M1121000900397

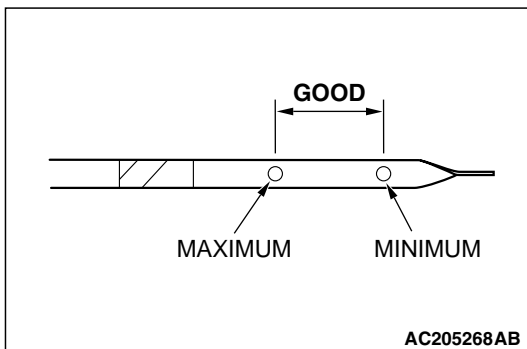

1. Pull out the oil dipstick slowly and check that the oil level is within the marks on the oil dipstick.
2. Check that the oil is not excessively dirty, that there is no coolant or gasoline mixed in, and that it is sufficiently thick and slippery.

ENGINE OIL REPLACEMENT

M1121001000706

1. Start the engine and allow it to warm up until the temperature of the coolant reaches 80 – 90°C (176 – 194°F).

⚠ WARNING

Use care as oil could be hot.

2. Remove the engine oil filler cap.
3. Remove the drain plug to drain oil.

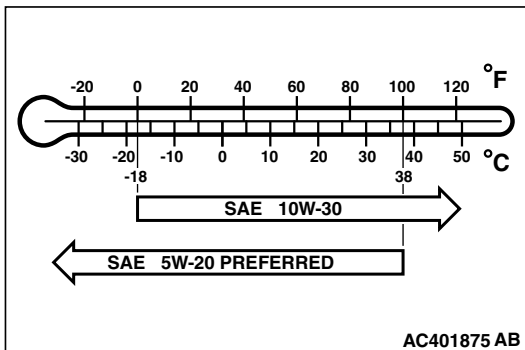
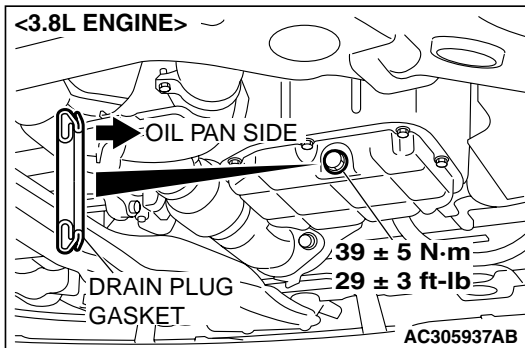
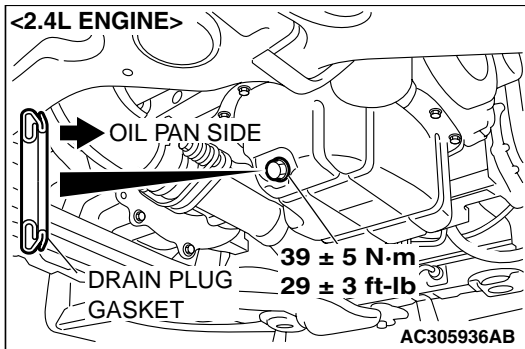

4. Install a new drain plug gasket so that it faces in the direction shown in the illustration, and then tighten the drain plug to the specified torque.

Tightening torque: $39 \pm 5 \text{ N}\cdot\text{m}$ ($29 \pm 3 \text{ ft}\cdot\text{lb}$)

5. Refill the specified quantity of oil.

Specified Engine Oil: Engine oils displaying ILSAC certification symbol ("Starburst" symbol) or conforming the API classification SL, SL/CF

Total quantity:

<2.4L Engine> 4.3 dm^3 (4.5 quarts)

<3.8L Engine> 4.6 dm^3 (4.9 quarts)

NOTE: SAE 5W-20 and SAE 10W-30 engine oil can be used in outdoor temperatures ranging from -18 to 38 °C (0 to 100 °F). However, for optimum fuel economy and cold starting, select the low SAE viscosity grade oil for the expected temperature range. SAE 5W-20 engine oil is recommended.

6. Install the engine oil filler cap.
7. Check oil level.

ENGINE OIL FILTER REPLACEMENT

M1121001100424

1. Start the engine and allow it to warm up until the temperature of the coolant reaches $80 - 90$ °C ($176 - 194$ °F).

⚠ WARNING

Use care as oil could be hot.

2. Remove the engine oil filler cap.
3. Remove the drain plug to drain oil.

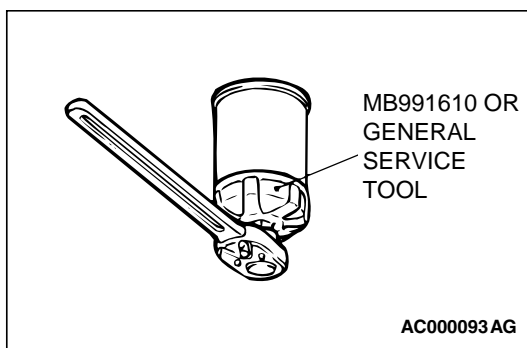

4. Use an oil filter wrench to remove the engine oil filter.
5. Clean the filter bracket side mounting surface and ensure the old O-ring has been removed.

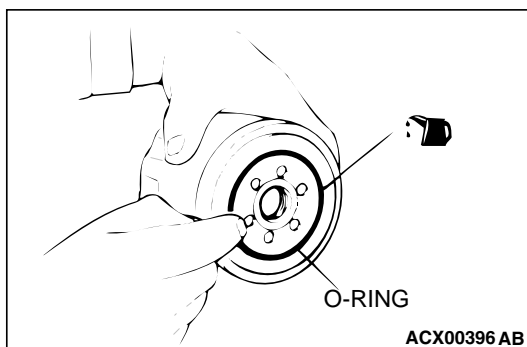

6. Apply a small amount of engine oil to the O-ring of the new oil filter.

7. Screw on the oil filter by hand until it touches the surface of the flange and then tighten it with an oil filter wrench.

NUMBER	ENGINE	SPECIAL TOOL	TIGHTENING TORQUE
MD136466, MD322508	2.4L	General service tool	Approximately 3/4 turn [17 ± 3 N·m (13 ± 2 ft-lb)]
MD356000		MB991610 or equivalent	Approximately 3/4 turn [14 ± 2 N·m (124 ± 18 in-lb)]
MD352627, MD321589	3.8L	General service tool	Approximately one turn [14 ± 2 N·m (124 ± 18 in-lb)]

8. Install the drain plug and refill engine oil (Refer to Engine Oil Replacement [P.12-3](#)).
9. Rev the engine a few times, and check to be sure that no engine oil leaks at the oil filter.

ENGINE OIL PRESSURE CHECK

Required Special Tool:

MD998054: Engine Oil Pressure Switch Wrench

1. Check engine oil quantity.

CAUTION

Since sealant is applied to the thread of the engine oil pressure switch, take care not to damage the engine oil pressure switch when removing it.

2. Use special tool MD998054 to remove the engine oil pressure switch.

NOTE: Remove the terminal of oil pressure switch where special tool MD998054 is not fitted.

3. Install the engine oil pressure gauge.

NOTE: Use a 1/8 pipe thread adapter.

4. Run the engine to warm it.

5. After the engine has been warmed up, check that engine oil pressure is within the standard value.

Standard value:

At idle: 29 kPa (4.2 psi) or more

At 3,500 r/min: 294 – 686 kPa (43 – 100 psi)

6. Remove the engine oil pressure gauge.

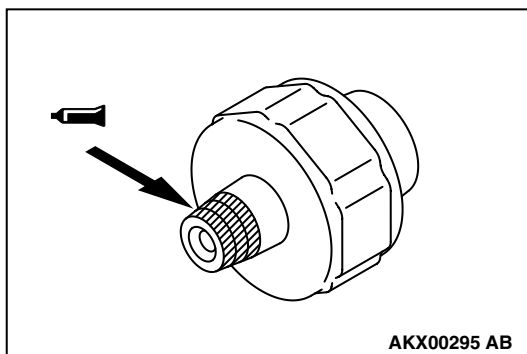
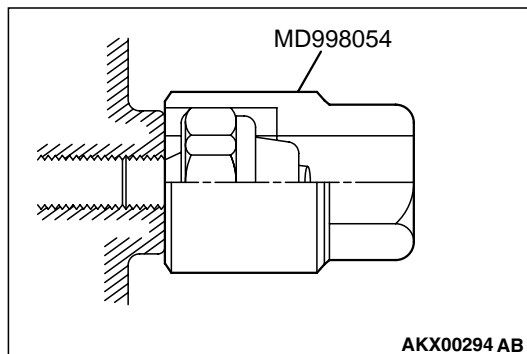
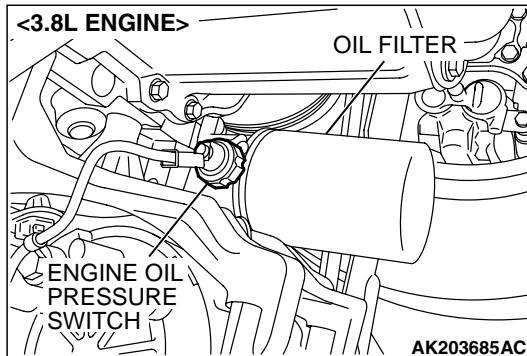
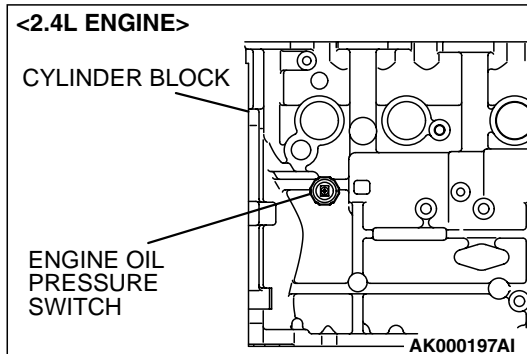

7. Apply the specified sealant 3M™ AAD Part number 8672 or equivalent to the threads of the engine oil pressure switch.

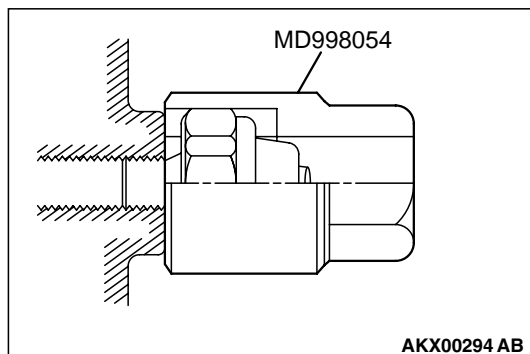

⚠ CAUTION

Do not start the engine within one hour after the engine engine oil pressure switch has been installed.

8. Use special tool MD998054 to tighten the engine oil pressure switch to the specified torque.

Tightening torque:

<2.4L ENGINE> 19 ± 3 N·m (14 ± 2 ft-lb)

<3.8L ENGINE> 10 ± 2 N·m (87 ± 17 in-lb)

SPECIFICATIONS

FASTENER TIGHTENING SPECIFICATIONS

M1121002200305

ITEM		SPECIFICATION
Engine oil filter	MD352627, MD321589, MD356000	14 ± 2 N·m (124 ± 18 in-lb)
	MD136466, MD322508	17 ± 3 N·m (13 ± 2 ft-lb)
Engine oil pan drain plug		39 ± 5 N·m (29 ± 3 ft-lb)
Engine oil pressure switch	2.4L Engine	19 ± 3 N·m (14 ± 2 ft-lb)
	3.8L Engine	10 ± 2 N·m (87 ± 17 in-lb)

SERVICE SPECIFICATIONS

M1121000300221

ITEM		STANDARD VALUE
Engine oil pressure kPa (psi)	at idle	29 (4.2) or more
	at 3,500 r/min	294 – 686 (43 – 100)

SEALANT

M1121000500225

ITEM	SPECIFIED SEALANT
Engine oil pressure switch	3M™ AAD Part No. 8672 or equivalent

LUBRICANT

M1121000400701

ITEM		ENGINE OIL	QUANTITY dm ³ (qt)
Oil filter		Engine oils displaying ILSAC certification symbol ("Starburst" symbol) or conforming to the API classification SL, SL/CF	0.3 (0.32)
Total quantity	2.4 L Engine		4.3 (4.5)
	3.8 L Engine		4.6 (4.9)

ENGINE OIL

 CAUTION

Never use nondetergent or straight mineral oil.

Use only engine oils displaying the ILSAC certification mark ("Starburst" symbol) on the container.

ILSAC CERTIFICATION MARK
("STARBURST" SYMBOL)



ACX00394 AI

API SERVICE SYMBOL

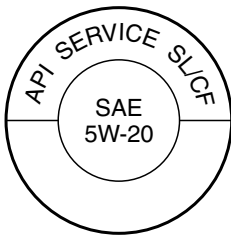

AC401876 AB

If these oils are not available, an API classification SL or SL/CF can be used.