

GROUP 37

POWER STEERING

CONTENTS

GENERAL DESCRIPTION	37-3	BLEEDING	37-21
POWER STEERING DIAGNOSIS . . .	37-4	OIL PUMP PRESSURE TEST	37-22
INTRODUCTION TO POWER STEERING		POWER STEERING PRESSURE SWITCH	
DIAGNOSIS	37-4	CHECK	37-23
POWER STEERING DIAGNOSIS		TIE ROD END BALL JOINT DUST COVER	
TROUBLESHOOTING STRATEGY	37-4	CHECK	37-24
SYMPTOM CHART	37-4	STEERING COLUMN SHAFT ASSEMBLY	
SYMPTOM PROCEDURES	37-5	SHOCK ABSORBING MECHANISM CHECK	37-24
SPECIAL TOOLS	37-14	STEERING WHEEL*	37-26
ON-VEHICLE SERVICE	37-17	REMOVAL AND INSTALLATION	37-26
STEERING WHEEL FREE PLAY CHECK .	37-17	STEERING SHAFT*	37-28
STEERING ANGLE CHECK	37-18	REMOVAL AND INSTALLATION	37-28
TIE ROD END BALL JOINT BREAKAWAY		DISASSEMBLY AND ASSEMBLY	37-31
TORQUE CHECK	37-18	POWER STEERING GEAR BOX AND	
STATIONARY STEERING EFFORT CHECK	37-19	LINKAGE*	37-33
STEERING WHEEL RETURN TO CENTER		REMOVAL AND INSTALLATION	37-33
CHECK	37-20	INSPECTION	37-39
DRIVE BELT TENSION CHECK	37-20	DISASSEMBLY AND ASSEMBLY	37-41
FLUID LEVEL CHECK	37-20	INSPECTION	37-54
FLUID REPLACEMENT	37-21		
POWER STEERING SYSTEM AIR			

Continued on next page

WARNINGS REGARDING SERVICING OF SUPPLEMENTAL RESTRAINT SYSTEM (SRS) EQUIPPED VEHICLES**⚠ WARNING**

- *Improper service or maintenance of any component of the SRS, or any SRS-related component, can lead to personal injury or death to service personnel (from inadvertent firing of the air bag) or to the driver and passenger (from rendering the SRS inoperative).*
- *Service or maintenance of any SRS component or SRS-related component must be performed only at an authorized MITSUBISHI dealer.*
- *MITSUBISHI dealer personnel must thoroughly review this manual, and especially its GROUP 52B - Supplemental Restraint System (SRS) before beginning any service or maintenance of any component of the SRS or any SRS-related component.*

NOTE

The SRS includes the following components: SRS air bag control unit, SRS warning light, front impact sensors, air bag module, clock spring, and interconnecting wiring. Other SRS-related components (that may have to be removed/installed in connection with SRS service or maintenance) are indicated in the table of contents by an asterisk (*).

POWER STEERING OIL PUMP ASSEMBLY **37-55**
 REMOVAL AND INSTALLATION
 <2.4L ENGINE> 37-55
 REMOVAL AND INSTALLATION
 <3.8L ENGINE> 37-56
 INSPECTION 37-57

POWER STEERING HOSES..... **37-58**

 REMOVAL AND INSTALLATION 37-58

SPECIFICATIONS **37-64**
 FASTENER TIGHTENING SPECIFICATIONS 37-64
 GENERAL SPECIFICATIONS 37-65
 SERVICE SPECIFICATIONS 37-66
 LUBRICANTS 37-67
 SEALANT 37-67

GENERAL DESCRIPTION

M1372000100360

Power steering has been adopted in all vehicles to make the steering system easier to handle.

- A 4-spoke steering wheel is used.
- A steering column has a shock absorbing mechanism and a tilt steering mechanism.
- A rack and pinion steering gear is used.

- An oil pump responsive to engine RPM is used, to enhance steering stability at high speeds.
- The separate plastic resin oil reservoir is used to reduce weight and to make the fluid level checking easier.

<2.4L ENGINE>

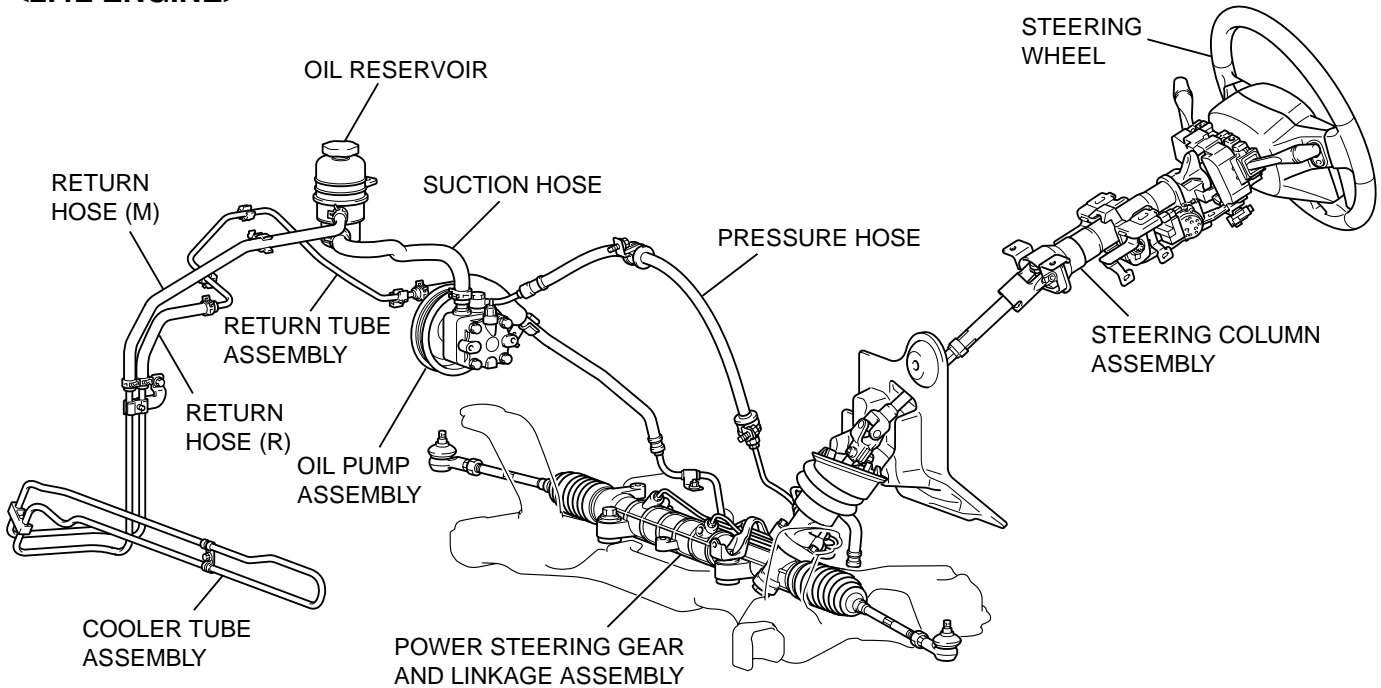

AC306240AB

<3.8L ENGINE>

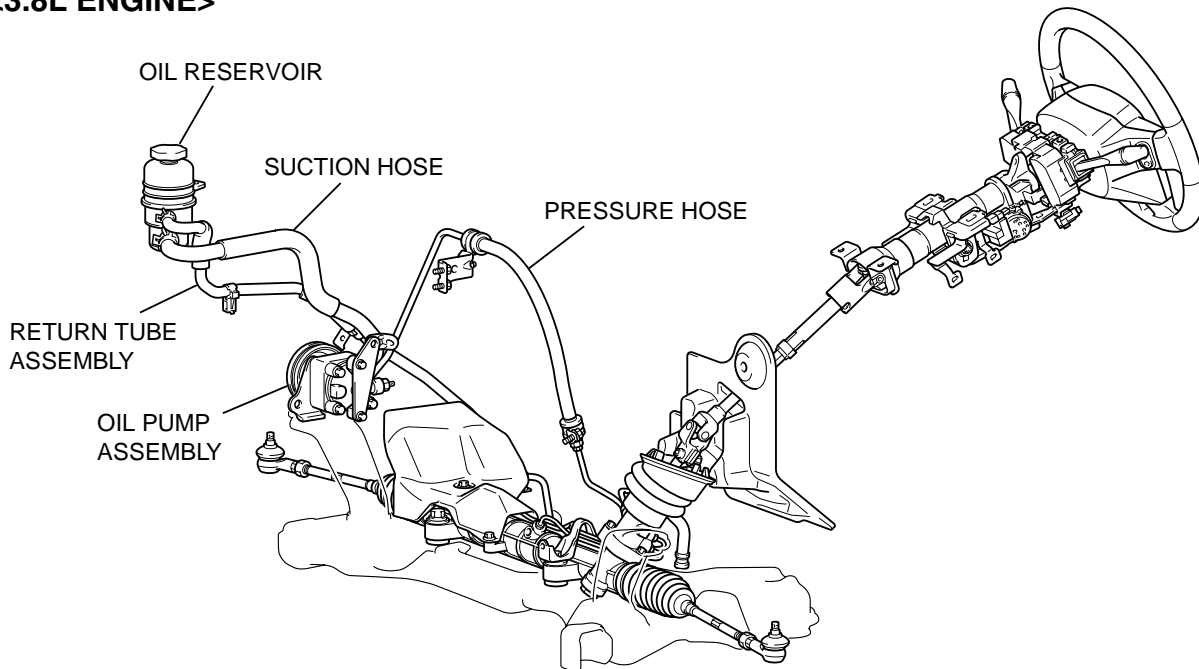

AC306241AB

POWER STEERING DIAGNOSIS**INTRODUCTION TO POWER STEERING DIAGNOSIS**

M1372008500209

Hydraulic power steering is used for all vehicles. Faults in the power steering can include excessive play of the steering wheel, difficult steering wheel operation, noise, vibration, and oil leaks, etc. Possible causes of these faults can include defects in the gear box, oil pump or steering linkage.

POWER STEERING DIAGNOSIS TROUBLESHOOTING STRATEGY

M1372007300202

Use these steps to plan your diagnostic strategy. If you follow them thoroughly, you will be sure that you have exhausted most of the possible ways to find a power steering fault.

1. Gather information from the customer.

2. Verify that the condition described by the customer exists.

3. Find the malfunction by following the Symptom Chart.

4. Verify malfunction is eliminated.

SYMPTOM CHART

M1372007600225

SYMPTOM	INSPECTION PROCEDURE	REFERENCE PAGE
Excessive play of steering wheel	1	P.37-5
Difficult steering wheel operation (insufficient power assist)	2	P.37-5
Rattling noise	3	P.37-7
Shrill noise	4	P.37-8
Squealing noise	5	P.37-8
Hissing noise	6	P.37-9
Droning noise	7	P.37-9
Squeaking noise	8	P.37-10
Vibration	9	P.37-11
Oil leakage from hose connection	10	P.37-12
Oil leakage from hose assembly	11	P.37-12
Oil leakage from oil reservoir	12	P.37-12
Oil leakage from oil pump	13	P.37-13
Oil leakage from steering gear	14	P.37-13

SYMPTOM PROCEDURES

INSPECTION PROCEDURE 1: Excessive Play of Steering Wheel

DIAGNOSIS

STEP 1. Check for looseness at the steering shaft coupling section and at the steering wheel linkage.

Q: Is there any looseness?

YES : Repair or replace the part. And then go to Step 3.

NO : Go to Step 2.

STEP 2. Check the steering wheel free play.

(1) With the engine running (hydraulic operation), set the front wheels straight ahead.

(2) Slightly move the steering wheel in both directions, and measure the play on the steering wheel circumference before the wheels start to move.

Limit: 30 mm (1.2 inch)

(3) If the free play exceeds the limit, set the steering wheel straight ahead with the engine stopped. Apply approximately 5 N (1.1 pound) to the steering circumference and check the play.

Standard value (steering wheel play with engine stopped): 10 mm (0.4 inch) or less

Q: Does the play exceed the standard value?

YES : Remove the steering gear box (refer to [P.37-33](#)) and check the total pinion torque (refer to [P.37-41](#)). And then go to Step 3.

NO : Go to Step 3.

STEP 3. Check the steering wheel play.

Verify that the steering wheel play is not excessive.

Q: Is the steering wheel play excessive?

YES : Repeat from Step 1.

NO : The procedure is complete.

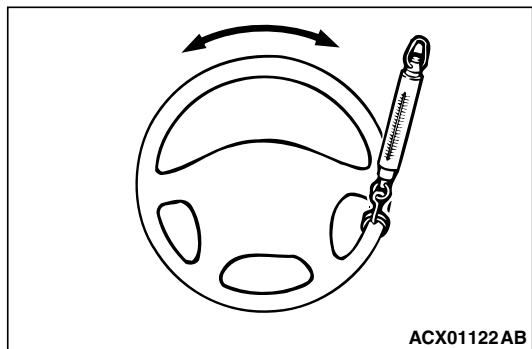

INSPECTION PROCEDURE 2: Difficult Steering Wheel Operation (Insufficient Power Assist)

DIAGNOSIS

STEP 1. Check the drive belt for damage.

Q: Is the drive belt damaged?

YES : Replace the drive belt. And then go to Step 9.

NO : Go to Step 2.

STEP 2. Check the power steering oil pump drive belt tension.

Refer to GROUP 00, Maintenance Service – Drive Belts P.00-45.

Q: Is the power steering oil pump drive belt tension within the standard value?

YES : Go to Step 3.

NO : Adjust the tension (refer to GROUP 00, Maintenance Service – Drive Belts P.00-45). And then go to Step 9.

STEP 3. Check the fluid level.

- (1) Park the vehicle on a flat, level surface, and then start the engine.
- (2) Turn the steering wheel several times to raise the temperature of the fluid to approximately 50 – 60°C (122 – 140°F).
- (3) With the engine running, turn the wheel all the way to the left and right several times.
- (4) Check the fluid in the oil reservoir for foaming or milkiness. Check the difference of the fluid level when the engine is stopped, and while it is running.

Q: Is the check result OK?

YES : Go to Step 4.

NO : Bleed the air (refer to P.37-21). And then go to Step 9.

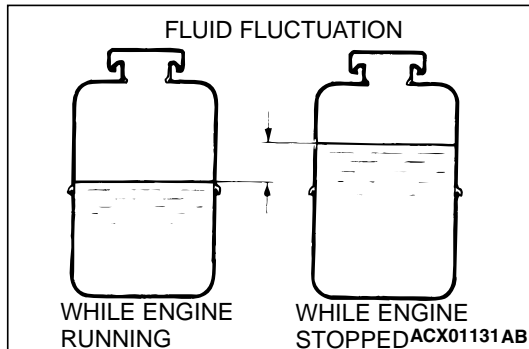
**STEP 4. Check each hose for crushing or twisting.****Q: Is any hose crushed or twisted?**

YES : Repair or replace the hose. And then go to Step 9.

NO : Go to Step 5.

STEP 5. Check for oil leaks.**Q: Are there oil leaks?**

YES : Find the cause of the oil leakage and repair it. And then go to Step 9.

NO : Go to Step 6.

STEP 6. Check the wheel alignment (camber and caster).

Refer to GROUP 33, On-vehicle Service – Front Wheel Alignment Check and Adjustment P.33-6.

Q: Is the wheel alignment incorrect?

YES : Adjust wheel alignment. And then go to Step 9.

NO : Go to Step 7.

STEP 7. Check the gear box rack piston seal for damage.

Q: Is there damage?

YES : Replace it. And then go to Step 9.

NO : Go to Step 8.

STEP 8. Check for excessive tie rod end ball joint breakaway torque.

Refer to [P.37-18](#).

Q: Is the breakaway torque out of specification?

YES : Replace the tie rod end. And then go to Step 9.

NO : Go to Step 9.

STEP 9. Check the steering wheel operation.

Verify that the steering wheel operation is not difficult.

Q: Is the steering wheel operation difficult?

YES : Repeat from Step 1.

NO : The procedure is complete.

INSPECTION PROCEDURE 3: Rattling Noise

DIAGNOSIS

STEP 1. Check for proper oil pump and steering gear installation.

Q: Is the oil pump and the steering gear installation correct?

YES : Go to Step 2.

NO : Repair it. And then go to Step 4.

STEP 2. Check for interference of other parts with the steering column and the power steering hoses.

Q: Is there interference?

YES : Correct the interference. And then go to Step 4.

NO : Go to Step 3.

STEP 3. Check for noise from inside the oil pump or the steering gear.

Q: Is there noise?

YES : Replace the part. And then go to Step 4.

NO : Go to Step 4.

STEP 4. Check for rattling noise.

Confirm that no noise is generated.

Q: Is there noise?

YES : Repeat from Step 1.

NO : The procedure is complete.

INSPECTION PROCEDURE 4: Shri11 Noise

DIAGNOSIS

STEP 1. Check the fluid level.

- (1) Park the vehicle on a flat, level surface, and then start the engine.
- (2) Turn the steering wheel several times to raise the temperature of the fluid to approximately 50 – 60°C (122 – 140°F).
- (3) With the engine running, turn the wheel all the way to the left and right several times.
- (4) Check the fluid in the oil reservoir for foaming or milkiness. Check the difference of the fluid level when the engine is stopped, and while it is running.

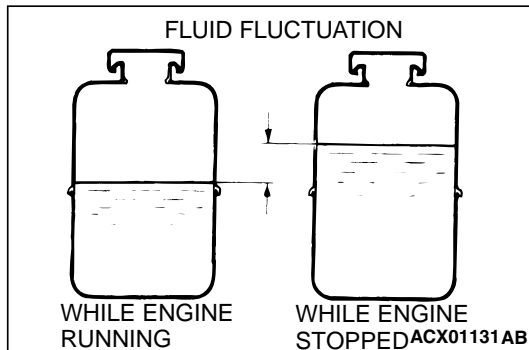
**Q: Is the check result OK?****YES** : Go to Step 2.**NO** : Bleed the air (Refer to [P.37-21](#)). And then go to Step 3.**STEP 2. Check for seizure in the oil pump.****Q: Is there seizure?****YES** : Replace the part. And then go to Step 3.**NO** : Go to Step 3.**STEP 3. Retest the system.**

Confirm that no noise is generated.

Q: Is there noise?**YES** : Repeat from Step 1.**NO** : The procedure is complete.

INSPECTION PROCEDURE 5: Squealing Noise

DIAGNOSIS

STEP 1. Check the drive belt tension.Refer to GROUP 00, Maintenance Service – Drive Belts [P.00-45](#).**Q: Is the drive belt tension incorrect?****YES** : Adjust the belt tension. (Refer to GROUP 00, Maintenance Service – Drive Belts [P.00-45](#)). And then go to Step 3.**NO** : Go to Step 2.**STEP 2. Check for seizure in the oil pump.****Q: Is there seizure?****YES** : Replace the part. And then go to Step 3.**NO** : Go to Step 3.**STEP 3. Retest the system.**

Confirm that no noise is generated.

Q: Is there noise?**YES** : Repeat from Step 1.**NO** : The procedure is complete.

INSPECTION PROCEDURE 6: Hissing Noise

DIAGNOSIS

STEP 1. Check the fluid level.

- (1) Park the vehicle on a flat, level surface, and then start the engine.
- (2) Turn the steering wheel several times to raise the temperature of the fluid to approximately 50 – 60°C (122 – 140°F).
- (3) With the engine running, turn the wheel all the way to the left and right several times.
- (4) Check the fluid in the oil reservoir for foaming or milkiness. Check the difference of the fluid level when the engine is stopped, and while it is running.

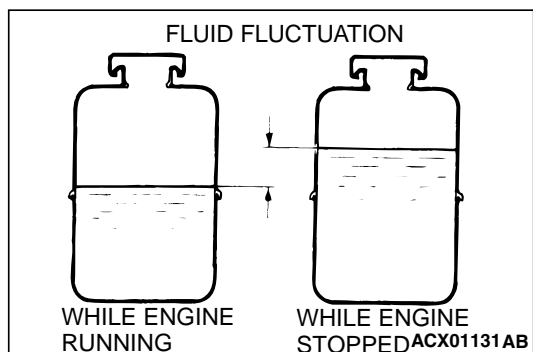

Q: Is the check result OK?

YES : Go to Step 2.

NO : Bleed the air (Refer to P.37-21). And then go to Step 4.

STEP 2. Check each hose for crushing or twisting.

Q: Is any hose crushed or twisted?

YES : Repair or replace the hose. And then go to Step 4.

NO : Go to Step 3.

STEP 3. Check the steering gear for damage.

Q: Is there damage?

YES : Repair or replace the part. And then go to Step 4.

NO : Go to Step 4.

STEP 4. Retest the system.

Confirm that no noise is generated.

Q: Is there noise?

YES : Repeat from Step 1.

NO : The procedure is complete.

INSPECTION PROCEDURE 7: Droning Noise

NOTE: If a slight "beat noise" is produced by the oil pump when the steering wheel is turned fully and held in that position, this is normal.

DIAGNOSIS

STEP 1. Check the oil pump or oil pump bracket installation.

Q: Is the oil pump or the oil pump bracket installation correct?

YES : Go to Step 2.

NO : Repair it. And then go to Step 3.

STEP 2. Check the oil pump for damage.

Q: Is there damage?

YES : Replace the oil pump. And then go to Step 3.

NO : Go to Step 3.

STEP 3. Retest the system.

Confirm that no noise is generated.

Q: Is there noise?

YES : Repeat from Step 1.

NO : The procedure is complete.

INSPECTION PROCEDURE 8: Squeaking Noise

DIAGNOSIS

STEP 1. Check for interference of the wheel and the vehicle body.

If interfering, adjust the steering angle.

- (1) Place the front wheel on a turning radius gauge and measure the steering angle.

Standard value:

ITEM	GTS MODELS	OTHER MODELS
Inner wheel	33°48' ± 2°00'	37°12' ± 2°00'
Outer wheel (reference)	28°18'	30°18'

- (2) If the steering angle is not within the standard value, adjust the toe.

Standard value: 0 ± 3 mm (0 ± 0.12 inch)

- (3) Adjust the toe by undoing the clip and jam nut, and turning the left and right tie rod turnbuckles by the same amount (in opposite directions).

NOTE: The toe will move out as the left turnbuckle is turned toward the front of the vehicle and the right turnbuckle is turned toward the rear of the vehicle.

Q: Is the steering angle normal?

YES : Go to Step 2.

NO : Repeat the toe adjustment. And then go to Step 3.

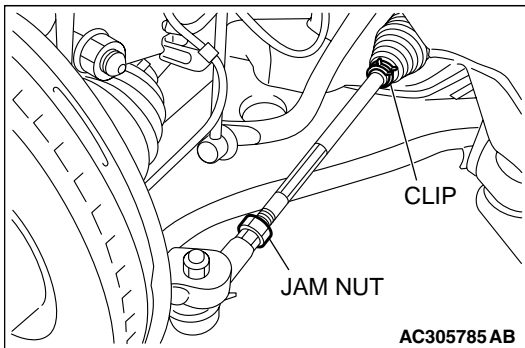
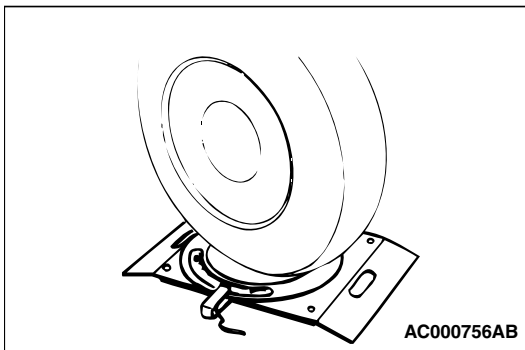

STEP 2. Check the steering gear for damage.

Q: Is there damage?

YES : Repair or replace the part. And then go to Step 3.

NO : Go to Step 3.

STEP 3. Retest the system.

Confirm that no noise is generated.

Q: Is there noise?

YES : Repeat from Step 1.

NO : The procedure is complete.

INSPECTION PROCEDURE 9: Vibration

NOTE: A slight vibration may be felt when the stationary steering effort is made due to the condition of the road surface. To check whether the vibration actually exists or not, test-drive the vehicle on a dry concrete or asphalt surface. A very slight amount of vibration is not a malfunction.

DIAGNOSIS

STEP1. Check the tires for out-of-balance.

Q: Is the check result OK?

YES : Go to Step 2.

NO : Balance the tires (Refer to GROUP 31, Wheel and Tire Diagnosis – Wheel Balance Accuracy P.31-3). And then go to Step 4.

STEP 2. Check the fluid level.

- (1) Park the vehicle on a flat, level surface, and then start the engine.
- (2) Turn the steering wheel several times to raise the temperature of the fluid to approximately 50 – 60°C (122 – 140°F).
- (3) With the engine running, turn the wheel all the way to the left and right several times.
- (4) Check the fluid in the oil reservoir for foaming or milkiness. Check the difference of the fluid level when the engine is stopped, and while it is running.

Q: Is the check result OK?

YES : Go to Step 3.

NO : Bleed the air (Refer to P.37-21). And then go to Step 4.

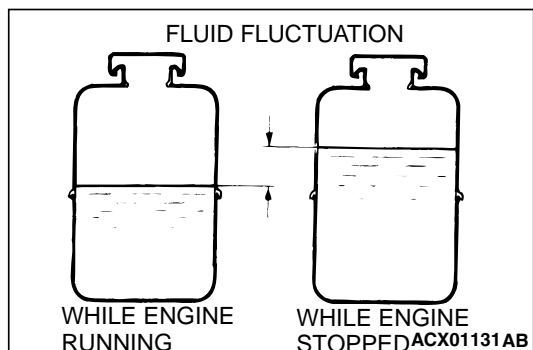

STEP 3. Check the steering gear for damage.

Q: Is there damage?

YES : Repair or replace the part. And then go to Step 4.

NO : Go to Step 4.

STEP 4. Retest the system.

Confirm that there is no steering wheel vibration.

Q: Is there vibration?

YES : Repeat from Step 1.

NO : The procedure is complete.

INSPECTION PROCEDURE 10: Oil Leakage from Hose Connection**DIAGNOSIS**

STEP 1. Check for loosening of the pressure/return tube flare nut.

Q: Is the flare nut loose?

YES : Tighten it to 15 ± 3 N·m (11 ± 2 ft-lb). And then go to Step 3.

NO : Go to Step 2.

STEP 2. Check the hose connection and the clamp installation.

Refer to [P.37-58](#).

Q: Are they correct?

YES : Go to Step 3.

NO : Correct hose connection and/or clamp installation. And then go to Step 3.

STEP 3. Retest the system.

Check that no oil is leaking.

Q: Is there oil leakage?

YES : Repeat from Step 1.

NO : The procedure is complete.

INSPECTION PROCEDURE 11: Oil Leakage from Hose Assembly**DIAGNOSIS**

STEP 1. Check the hose for damage or clogging.

Q: Is the hose damaged or clogged?

YES : Repair or replace it. And then go to Step 2.

NO : Go to Step 2.

STEP 2. Retest the system.

Check that no oil is leaking.

Q: Is there oil leakage?

YES : Repeat from Step 1.

NO : The procedure is complete.

INSPECTION PROCEDURE 12: Oil Leakage from Oil Reservoir**DIAGNOSIS**

STEP 1. Check the oil reservoir for damage.

Q: Is there damage?

YES : Repair or replace it. And then go to Step 3.

NO : Go to Step 2.

STEP 2. Check for overflowing.

Q: Is there oil overflowing from the reservoir?

YES : Adjust fluid level. And then go to Step 3.

NO : Go to Step 3.

STEP 3. Retest the system.

Q: Is there oil leakage?

YES : Repeat from Step 1.

NO : The procedure is complete.

INSPECTION PROCEDURE 13: Oil Leakage from Oil Pump

DIAGNOSIS

STEP 1. Check the oil pump body for damage.

Q: Is there damage?

YES : Replace the part. And then go to Step 3.

NO : Go to Step 2.

STEP 2. Check the O-ring or oil seal for damage.

Q: Is there damage?

YES : Replace the part. And then go to Step 3.

NO : Go to Step 3.

STEP 3. Retest the system.

Check that no oil is leaking.

Q: Is there oil leakage?

YES : Repeat from Step 1.

NO : The procedure is complete.

INSPECTION PROCEDURE 14: Oil Leakage from Steering Gear

DIAGNOSIS

STEP 1. Check the steering gear housing for damage.

Q: Is there damage?

YES : Replace the part. And then go to Step 2.

NO : Go to Step 2.

STEP 2. Retest the system.

Check that no oil is leaking.

Q: Is there oil leakage?

YES : Repeat from Step 1.



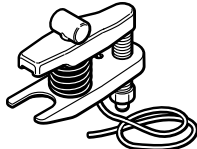
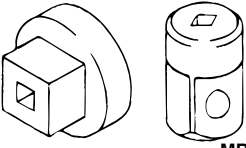
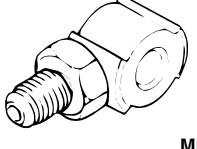
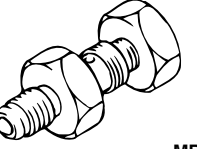
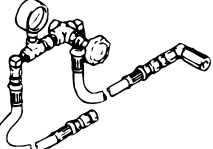
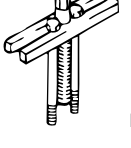
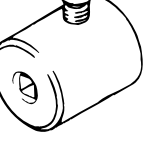

NO : The procedure is complete.

SPECIAL TOOLS

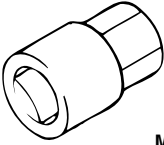
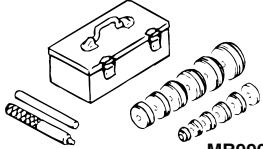
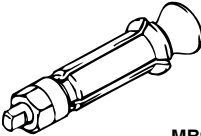
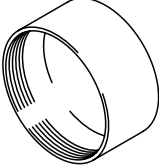
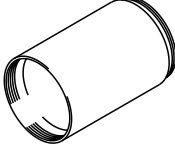
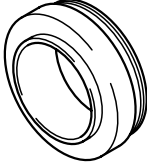
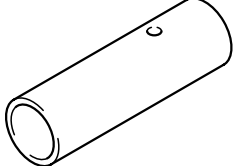
M1372000600387

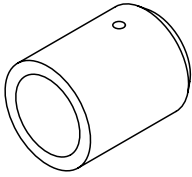
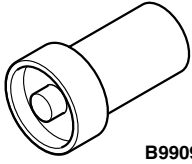
TOOL	TOOL NUMBER AND NAME	SUPERSESSION	APPLICATION
 AC106827	MB991897 Ball joint remover	MB991113-01, MB990635-01 or General service tool	Knuckle and tie rod end ball joint disconnection <i>NOTE: Steering linkage puller (MB990635 or MB991113) is also available to disconnect knuckle and tie rod end ball joint.</i>
 MB990326	MB990326 Preload socket	General service tool	Tie rod end ball joint breakaway torque check
 MB991548	MB991548 Power steering oil pressure gauge adapter (Pump side)	MB991548-01	Oil pump pressure test
 MB991549	MB991549 Power steering oil pressure gauge adapter (Hose side)	MB991549-01	
 MB990662	MB990662 Power steering oil pressure gauge	MB990662-01	
 MB990803	MB990803 Steering wheel puller	-	Steering wheel removal
 MB991006	MB991006 Preload socket	MB990228-01	Steering gear total pinion torque check

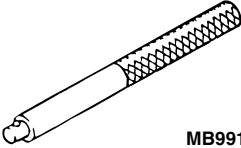
TOOL	TOOL NUMBER AND NAME	SUPERSESSION	APPLICATION
 <p align="center">MB991204</p>	MB991204 Torque wrench socket	General service tool	<ul style="list-style-type: none"> • Rack support adjustment • Rack support cover removal
 <p align="center">MB990925</p>	MB990925 Bearing and oil seal installer set	MB990925-01 or general service tool	<ul style="list-style-type: none"> • Oil seal and bearing installation • MB990927, MB990938, MB990939 (For details, refer to GROUP 26, Special Tools P.26-5.)
 <p align="center">MB991120</p>	MB991120 Needle bearing puller	Tool not available	Needle roller bearing removal
	MD998812 Installer cap	-	Gear housing mounting bushing removal
	MD998813 Installer 100	-	
	MD998822 Installer adapter	-	
	MD998368 Bearing installer	-	

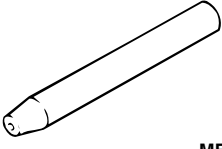
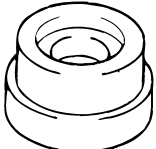
TOOL	TOOL NUMBER AND NAME	SUPERSESSION	APPLICATION
	MD999569 Camshaft oil seal installer	-	Gear housing mounting bushing installation
 B990996	MB990996 Lower arm bushing arbor	-	
 MB991199	MB991199 Oil seal installer	General service tool	Oil seal installation
 MB991197	MB991197 Bar (long type)	General service tool	
 MB991202	MB991202 Oil seal and bearing installer	General service tool	Needle roller bearing and ball bearing installation
 MB991212	MB991213 Rack installer	General service tool	Rack installation
 MB991203	MB991203 Oil seal and bearing installer	Tool not available	Oil seal and bearing installation

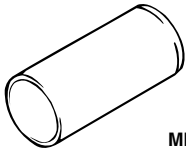
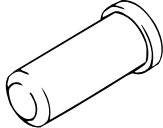
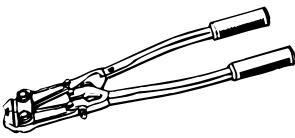
TOOL	TOOL NUMBER AND NAME	SUPERSESSION	APPLICATION
 MB991317	MB991317 Seal ring installer	Tool not available	Seal ring installation
 MB991152	MB991152 Dust cover installer	General service tool	Oil seal installation
 MB991561	MB991561 Boot band crimping tool	MB991561	Bellows band installation

ON-VEHICLE SERVICE

STEERING WHEEL FREE PLAY CHECK

M1372001000344

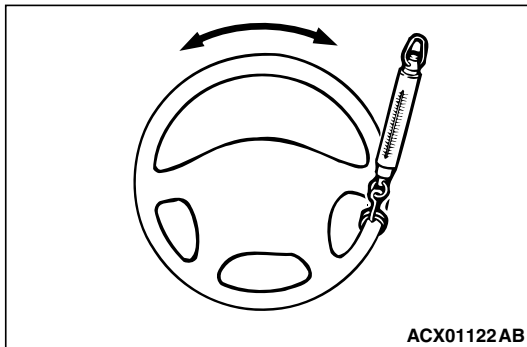

1. With the engine running (hydraulic operation), set the front wheels straight ahead.
2. Slightly move the steering wheel in both directions and measure the play on the steering wheel circumference before the wheels start to move.

Limit: 30 mm (1.2 inch)

3. If the play exceeds the limit, check on the steering shaft and steering linkage connection. Correct or replace.
4. If the free play still exceeds the limit value, set the steering wheel straight ahead with the engine stopped. Apply 5 N (1.1 pound) towards the steering wheel circumference and check the play.

Standard value (steering wheel play with the engine stopped): 10 mm (0.4 inch) or less

5. If the play exceeds the standard value, remove the steering gear (refer to [P.37-33](#)) and check the total pinion torque (refer to [P.37-41](#)).

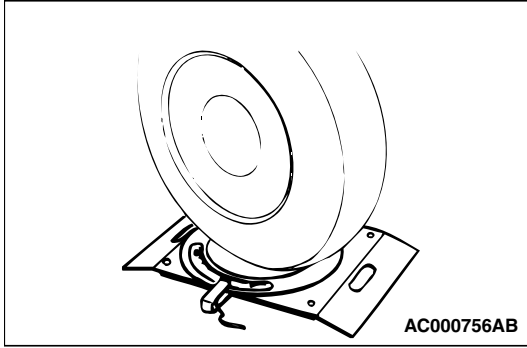

STEERING ANGLE CHECK

M1372001100396

1. Place the front wheel on a turning radius gauge and measure the steering angle.

Standard value:

ITEM	VEHICLES WITH 16-INCH WHEELS	VEHICLES WITH 17-INCH WHEELS
Inner wheel	37°12' ± 2°00'	33°48' ± 2°00'
Outer wheel (reference)	30°18'	28°18'

2. If the steering angle is not within the standard value, adjust the toe as follows.

Standard value: 0 ± 3 mm (0 ± 0.12 inch)

- (1) Loosen the jam nut, and unclip the bellows.
- (2) Adjust the toe by turning the left and right tie rod turnbuckles by the same amount (in opposite directions).

NOTE: The toe will move out as the left turnbuckle is turned toward the front of the vehicle and the right turnbuckle is turned toward the rear of the vehicle.

- (3) Tighten the jam nut to the specified torque, and tighten the bellows by the clip.

Tightening torque: 52 ± 2 N·m (38 ± 2 ft·lb)

3. Recheck the steering angle.

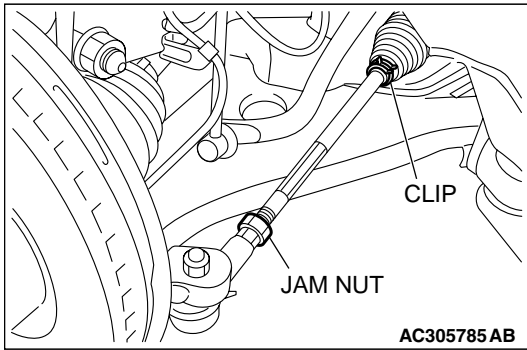

TIE ROD END BALL JOINT BREAKAWAY TORQUE CHECK

M1372001500305

Required Special Tools:

- MB990326: Preload Socket
- MB991897: Ball Joint Remover

⚠ CAUTION

- Do not remove the nut from ball joint. Loosen it and use special tool MB991897 to avoid possible damage to the ball joint threads.
- Hang special tool MB991897 with a cord to prevent it from falling.

1. Install special tool MB991897 as shown in the figure.

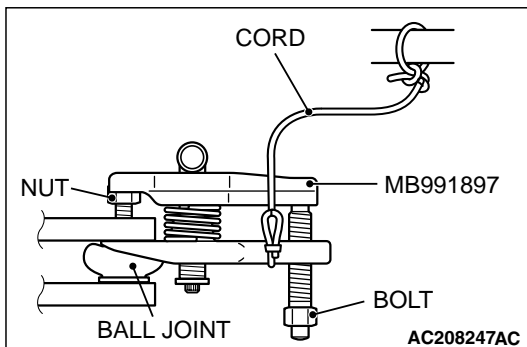

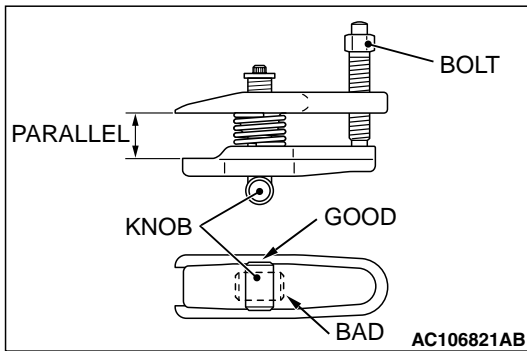

- Turn the bolt and knob as necessary to make the jaws of special tool MB991897 parallel, tighten the bolt by hand and confirm that the jaws are still parallel.

NOTE: When adjusting the jaws in parallel, make sure the knob is in the position shown in the figure.

- Tighten the bolt with a wrench to disconnect the tie rod end.

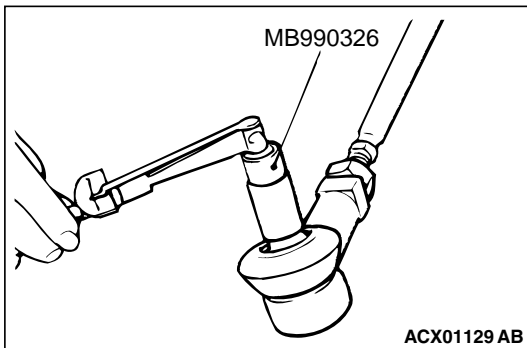

- Move the ball joint stud several times and install the nut on the stud. Using special tool MB990326, measure the ball joint breakaway torque.

Standard value: 0.5 – 3.5 N·m (4.4 – 31.0 in-lb)

- If the breakaway torque exceeds the standard value, replace the tie rod end assembly.
- If the breakaway torque is under the standard value, check the ball joint for end play or ratcheting. If there is no end play or ratcheting, the ball joint can be re-used.

⚠ CAUTION

Always use a new ball joint nut, as it is a self-locking nut.

- Install the tie rod end to the knuckle, then tighten a new self-locking nut to the specified torque.

Tightening torque: 29 ± 4 N·m (21 ± 3 ft-lb)

STATIONARY STEERING EFFORT CHECK

M1372001700354

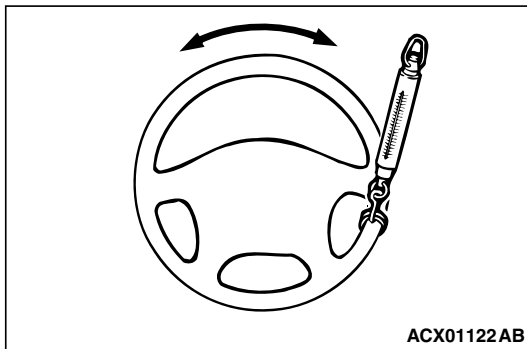

- With the vehicle stopped on a flat and paved surface, turn the steering wheel to the straight ahead position.
- Start the engine and allow to idle.
- Attach a spring scale to the outer circumference of the steering wheel and measure the steering force required to turn the steering wheel from the straight ahead position to the left and right (within a range of 1.5 turns). Also check to be sure that there is no significant change in the required steering effort.

Standard value:

Steering effort: 30 N (6.7 lb) or less

Fluctuation allowance: 5.9 N (1.33 lb) or less

- If the measured value exceeds the standard value, refer to Inspection Procedure 2 "Difficult Steering Wheel Operation (Insufficient Power Assist)" [P.37-5](#).

STEERING WHEEL RETURN TO CENTER CHECK

M1372001800339

Conduct a road test:

1. Make both gradual and sudden turns and check the steering wheel return.
2. At a vehicle speed of approximately 35 km/h (22 mph), turn the steering wheel 90 degrees, hold a few seconds, then release. If the steering wheel then returns 70 degrees or more, the return can be judged as satisfactory.

NOTE: There will be a momentary feeling or "heaviness" when the wheel is turned quickly, but this is not abnormal. (Oil pump discharge amount is especially apt to be insufficient during idling.)

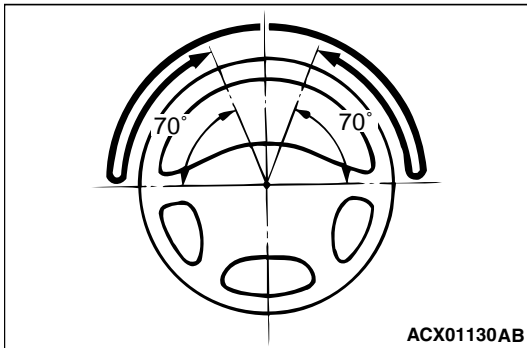
**DRIVE BELT TENSION CHECK**

M1372001900284

Refer to GROUP 00, Maintenance Service – Drive Belts

[P.00-45](#).

FLUID LEVEL CHECK

M1372002000303

1. Park the vehicle on a flat, level surface.
2. Start the engine, and then turn the steering wheel several times to raise the temperature of the fluid to approximately 50 – 60°C (122 – 140°F).
3. With the engine running, turn the wheel all the way to the left and right several times.
4. Check the fluid in the oil reservoir for foaming or milkiness. Check the difference of the fluid level when the engine is stopped, and while it is running. If the fluid contains air or has milky appearance, or the fluid level fluctuate by 5 mm (0.2 inch) or more, power steering system air bleeding should be done.

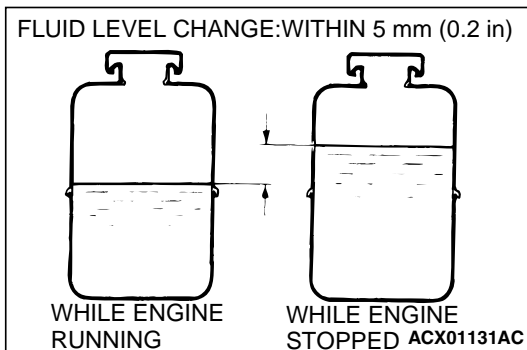

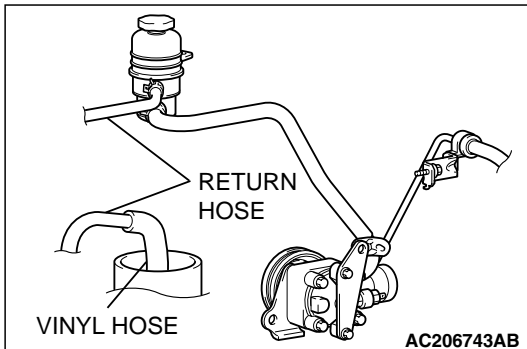

M1372002100366

FLUID REPLACEMENT

1. Raise and support the front wheels.
2. Disconnect the return hose connection, and then connect a vinyl hose to the return hose, and drain the fluid into a container.
3. Disconnect the ignition coil connectors (refer to GROUP 16, Ignition Coil P. 16-40 <2.4L ENGINE>, P. 16-41 <3.8L ENGINE>).
4. While operating the starter motor intermittently, turn the steering wheel all the way to the left and right several times to drain all of the fluid.
5. Connect the return hose securely, and then secure with the clip.
6. Fill the oil reservoir with GENUINE MITSUBISHI POWER STEERING FLUID up to the lower mark of the reservoir, and then bleed the air.

POWER STEERING SYSTEM AIR BLEEDING

M1372002200352

Perform air bleeding procedure as necessary after replacing the steering gear, oil pump or the steering fluid lines.

1. Raise and support the front wheels.
2. Disconnect the ignition coil connectors (Refer to GROUP 16, Ignition Coil P. 16-40 <2.4L ENGINE>, P. 16-41 <3.8L ENGINE>).

⚠ CAUTION

Perform air bleeding only while cranking the engine. Do not perform air bleeding while the engine is running. If you do so, air in the fluid will be increased and air bleeding will become more difficult. During air bleeding, refill the steering fluid so that the level never falls below the lower mark on the dipstick.

3. Turn the steering wheel all the way to the left and right five or six times while using the starter motor to crank the engine intermittently several times (for 15 to 20 seconds).
4. Connect the ignition coil connectors (Refer to GROUP 16, Ignition Coil P. 16-40 <2.4L ENGINE>, P. 16-41 <3.8L ENGINE>).
5. Start the engine and allow to idle.
6. Turn the steering wheel to the left and right until there are no air bubbles in the oil reservoir.
7. Confirm that the fluid is not milky, and that the level is between the high and low dipstick marks.
8. Confirm that there is very little change in the fluid level when the steering wheel is turned left and right.

⚠ CAUTION

If the fluid level rises suddenly after the engine is stopped, the air has not been completely bled. If air bleeding is not complete, there will be abnormal noises from the pump and the flow-control valve, and this condition could reduce the life of the power steering components.

9. Confirm that the change in the fluid level is no more than 5 mm (0.2 inch) when the engine is stopped.

10. If the change of the fluid level is 5 mm (0.2 inch) or more, the air has not been completely bled from the system. The air bleeding procedure must be repeated.

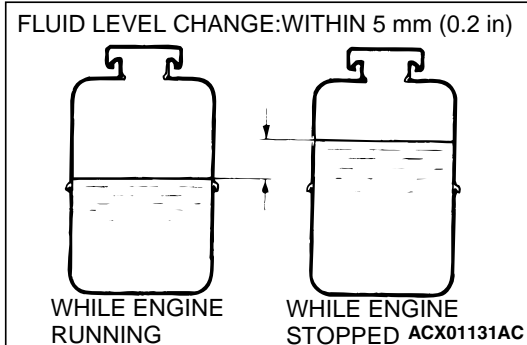
**OIL PUMP PRESSURE TEST**

M1372002300337

Required Special Tools:

- MB990662: Power Steering Oil Pressure Gauge
- MB991548: Power Steering Oil Pressure Gauge Adapter (Pump Side)
- MB991549: Power Steering Oil Pressure Gauge Adapter (Hose Side)

1. Disconnect the pressure hose from the oil pump, and then connect special tools MB991548, MB990662 and MB991549.
2. Bleed air, then turn the steering wheel several times while the vehicle is not moving so that the temperature of the fluid rises to approximately 50 – 60°C (122 – 140°F).
3. Start the engine and idle it.

⚠ CAUTION

The pressure gauge shut-off valve must not remain closed for more than 10 seconds.

4. Fully close the shut-off valve of the pressure gauge and measure the oil pump relief pressure to confirm that it is within the standard value range. Open it again immediately after checking the pressure.

Standard value:

2.4L engine: 8.3 – 8.8 MPa (1,204 – 1,276 psi)

3.8L engine: 9.3 – 9.8 MPa (1,349 – 1,421 psi)

5. If it is not within the standard value, replace the oil pump.
6. Check whether or not the hydraulic pressure is the standard value when no-load conditions are created by fully opening the shut-off valve of the pressure gauge.

Standard value: 0.8 – 1.0 MPa (116 – 145 psi)

7. If it is not within the standard value, the probable cause is a malfunction of the oil line or steering gear, so check these parts and repair as necessary.

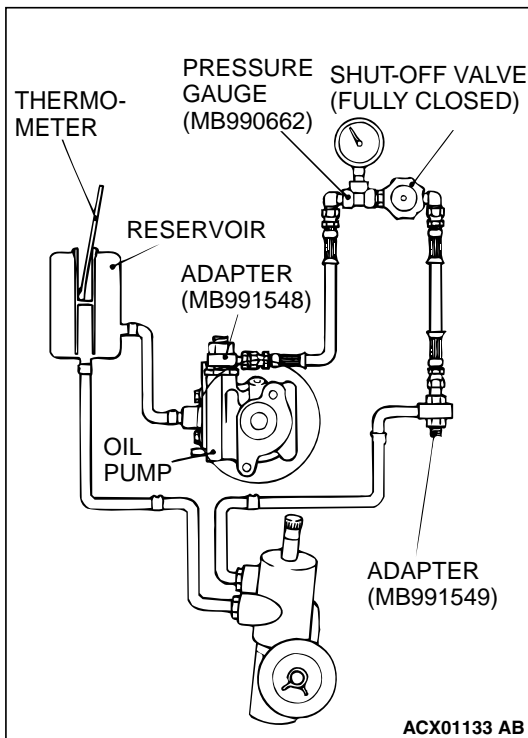

- Turn the steering wheel all the way to the left or right; then check the retention hydraulic pressure.

Standard value:

2.4L engine: 8.3 – 8.8 MPa (1,204 – 1,276 psi)

3.8L engine: 9.3 – 9.8 MPa (1,349 – 1,421 psi)

- If not the standard value, overhaul or replace the steering gear. Remeasure fluid pressure.
- Remove special tools MB991548, MB990662 and MB991549, connect the pressure hose to the oil pump, and then tighten the eye bolt to the specified torque.

Tightening torque: 57 ± 7 N·m (42 ± 5 ft-lb)

- Bleed the system (Refer to [P.37-21](#)).

POWER STEERING PRESSURE SWITCH CHECK

M1372007200346

Required Special Tools:

- MB990662: Power Steering Oil Pressure Gauge
- MB991548: Power Steering Oil Pressure Gauge Adapter (Pump Side)
- MB991549: Power Steering Oil Pressure Gauge Adapter (Hose Side)

- Disconnect the pressure hose from the oil pump, and then connect the special tools MB991548, MB990662 and MB991549.

- Bleed air, and then turn the steering wheel several times while the vehicle is not moving so that the temperature of the fluid rises to approximately 50 – 60°C (122 – 140°F).

- The engine should be idling.

- Disconnect the connector for the oil pressure switch, and place an ohmmeter at the switch.

- Gradually close the shut-off valve of the pressure gauge and increase the hydraulic pressure, then check whether or not the hydraulic pressure that activates the switch is the standard value.

Standard value: 1.8 – 2.4 MPa (261 – 348 psi)

- Gradually open the shut-off valve and reduce the hydraulic pressure; then check whether or not the hydraulic pressure that deactivates the switch is the standard value.

Standard value: 0.8 – 2.4 MPa (116 – 348 psi)

- Remove special tools MB991548, MB990662 and MB991549, connect the pressure hose to the oil pump, and then tighten the eye bolt to the specified torque.

Tightening torque: 57 ± 7 N·m (42 ± 5 ft-lb)

- Bleed the system. (Refer to [P.37-21](#)).

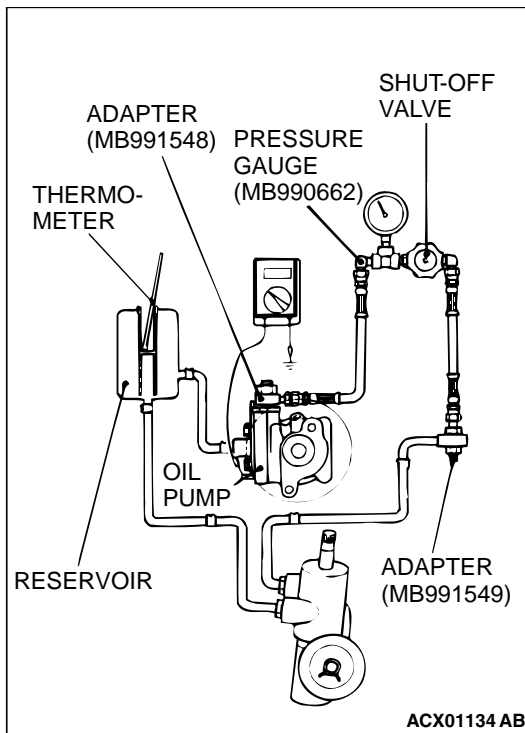

TIE ROD END BALL JOINT DUST COVER CHECK

M1372008600284

1. Press the dust cover with your finger to check whether the dust cover is cracked or damaged.
2. If the dust cover is cracked or damaged, replace the tie rod end.

NOTE: If the dust cover is cracked or damaged, the ball joint could be damaged.

STEERING COLUMN SHAFT ASSEMBLY SHOCK
ABSORBING MECHANISM CHECK

M1372013500131

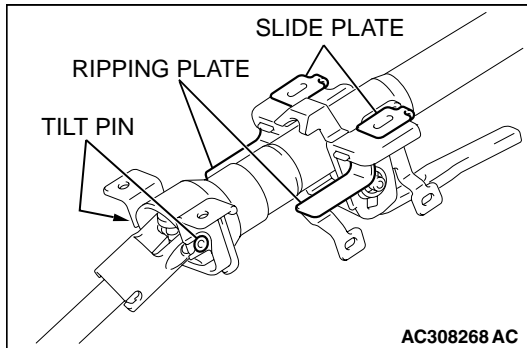

- If a collision occurs or severe impact is applied to the steering wheel, the collision energy absorbing mechanism (slide plate, ripping plate, tilt pin) may have operated. Once the mechanism has operated, it will be inoperative even if there is no apparent damage. Determine if the steering column shaft can be reused by the following procedure. If the collision energy absorbing mechanism has already operated, replace the steering column assembly.
- If any excessive radial or axial free play on the steering wheel is found with the tilt lever in the lock position, always check the steering column assembly.

⚠ WARNING

1. ***If the vehicle continues to be driven after the collision absorbing mechanism has operated, the steering column shaft may be damaged while driving.***
2. ***If there is a slack in the one-way capsule, do not attempt to repair it. Replace the steering column assembly.***

Inspection Procedure

1. Remove the steering column covers (lower and upper).

⚠ CAUTION

Do not release the tilt lever until the steering column has been installed to complete this inspection procedure.

2. Place the tilt lever in the locked position.
3. Loosen the two upper steering column mounting bolts by two turns.
4. Hold the steering wheel, and then try to rock it. If there is a radial or axial free play, replace the steering column assembly.

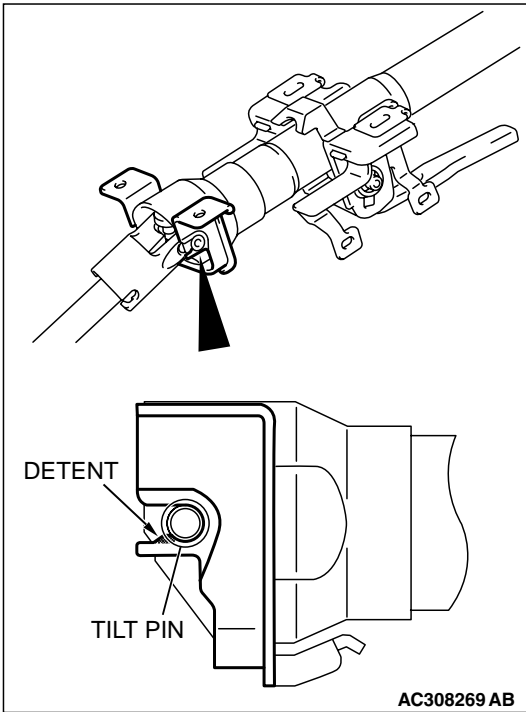

5. Check the tilt pin fixing detent of the lower bracket for deformation. If there is a deformation, replace the steering column assembly.

⚠ CAUTION

- Be careful that nothing is pinched between the one-way capsules and the body.
 - Do not release the tilt lever until the steering column has been installed to complete this inspection procedure.
6. If no problem is found during the inspection, tighten the steering column assembly mounting bolts to the specified torque.

Tightening torque: 12 ± 2 N·m (102 ± 22 in·lb)

STEERING WHEEL**REMOVAL AND INSTALLATION**

M1372011400224

⚠ WARNING

- Before removing the steering wheel and air bag module assembly, refer to **GROUP 52B, Service Precautions (P.52B-26)** and **Air Bag Module and Clock Spring (P.52B-369)**.
- When removing and installing the steering wheel, do not let it bump against the air bag module.

Post-installation Operation

- Checking Steering Wheel Position with Wheels Straight Ahead

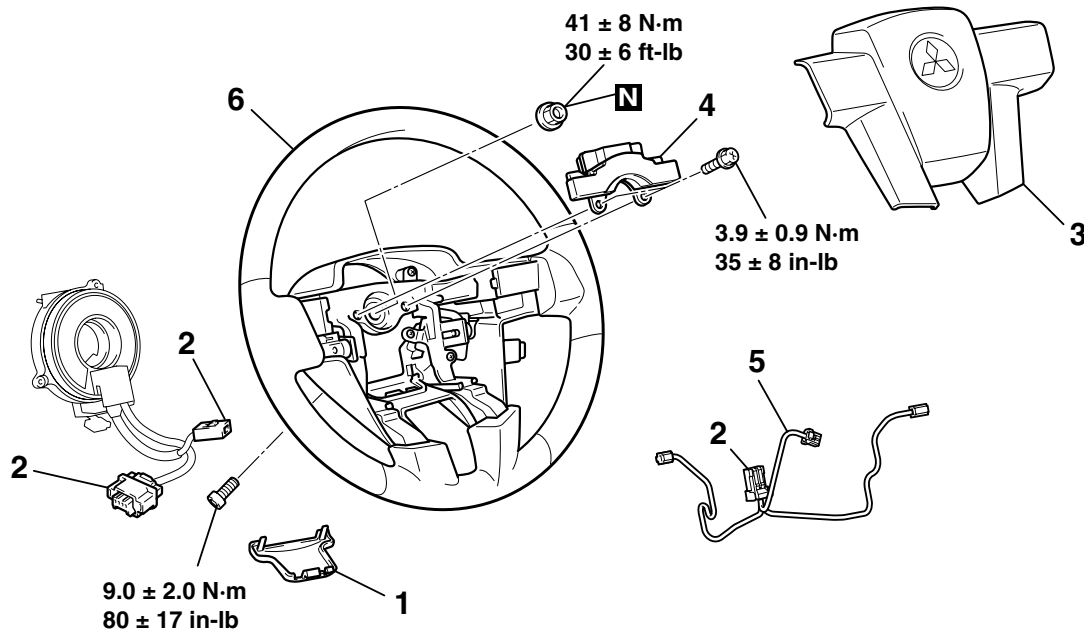

AC306560 AB

REMOVAL STEPS

- <<A>>
1. STEERING WHEEL LOWER COVER
 2. CONNECTORS (FOR HORN, AIR BAG MODULE, AND STEERING WHEEL REMOTE CONTROL HARNESS)
 3. AIR BAG MODULE
 4. STEERING WHEEL DYNAMIC DAMPER
 5. STEERING WHEEL REMOTE CONTROL HARNESS

<>

6. STEERING WHEEL ASSEMBLY
- INSTALLATION STEPS**
- CLOCK SPRING MATING MARK ALIGNMENT (REFER TO GROUP 52B, AIR BAG MODULE AND CLOCK SPRING P.52B-369).
6. STEERING WHEEL ASSEMBLY

INSTALLATION STEPS

5. STEERING WHEEL REMOTE CONTROL HARNESS
4. STEERING WHEEL DYNAMIC DAMPER
3. AIR BAG MODULE
2. CONNECTORS (FOR HORN, AIR BAG MODULE, AND STEERING WHEEL REMOTE CONTROL HARNESS)
1. STEERING WHEEL LOWER COVER

NOTE: For air bag module removal, refer to **GROUP 52B, Air Bag Module and Clock Spring P.52B-369**.

Required Special Tool:

- MB990803: Steering Wheel Puller

REMOVAL SERVICE POINTS

**<<A>> CONNECTOR (FOR AIR BAG MODULE)
REMOVAL**

Slide the outer housing of the clock spring connector in the arrow direction shown, and disconnect the connector.

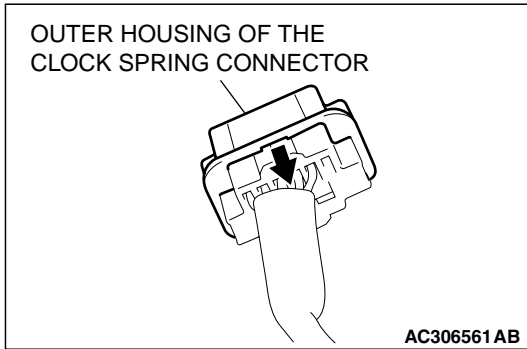

<>STEERING WHEEL ASSEMBLY REMOVAL

Use special tool MB990803 to remove the steering wheel.

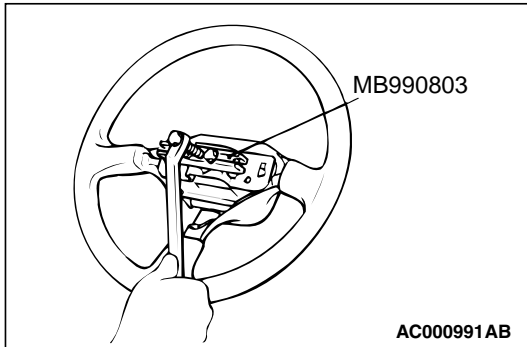

STEERING SHAFT

REMOVAL AND INSTALLATION

M1372011500135

⚠ WARNING

Before removing the air bag module and steering wheel assembly, refer to GROUP 52B, Service Precautions and Air Bag Module and Clock Spring (P.52B-26 and P.52B-369).

Pre-removal Operation	Post-installation Operation
<ul style="list-style-type: none"> • Air bag Module and Steering Wheel Assembly Removal (Refer to P.37-26). • Instrument Panel Lower Panel Removal (Refer to GROUP 52A, Instrument Panel P.52A-3). • Floor Console Assembly Removal (Refer to GROUP 52A, Floor Console Assembly P.52A-9). • Front Scuff Plate and Cowl Side Trim Removal (Refer to GROUP 52A, Trims P.52A-10). • Trunk Lid Opener Cover Removal • Accelerator Pedal Stopper Removal • Front Floor Carpet Removal 	<ul style="list-style-type: none"> • Front Floor Carpet Installation • Accelerator Pedal Stopper Installation • Trunk Lid Opener Cover Installation • Front Scuff Plate and Cowl Side Trim Installation (Refer to GROUP 52A, Trims P.52A-10). • Floor Console Assembly Installation (Refer to GROUP 52A, Floor Console Assembly P.52A-9). • Instrument Panel Lower Panel Installation (Refer to GROUP 52A, Instrument Panel P.52A-3). • Steering Wheel Assembly and Air bag Module Installation (Refer to P.37-26).

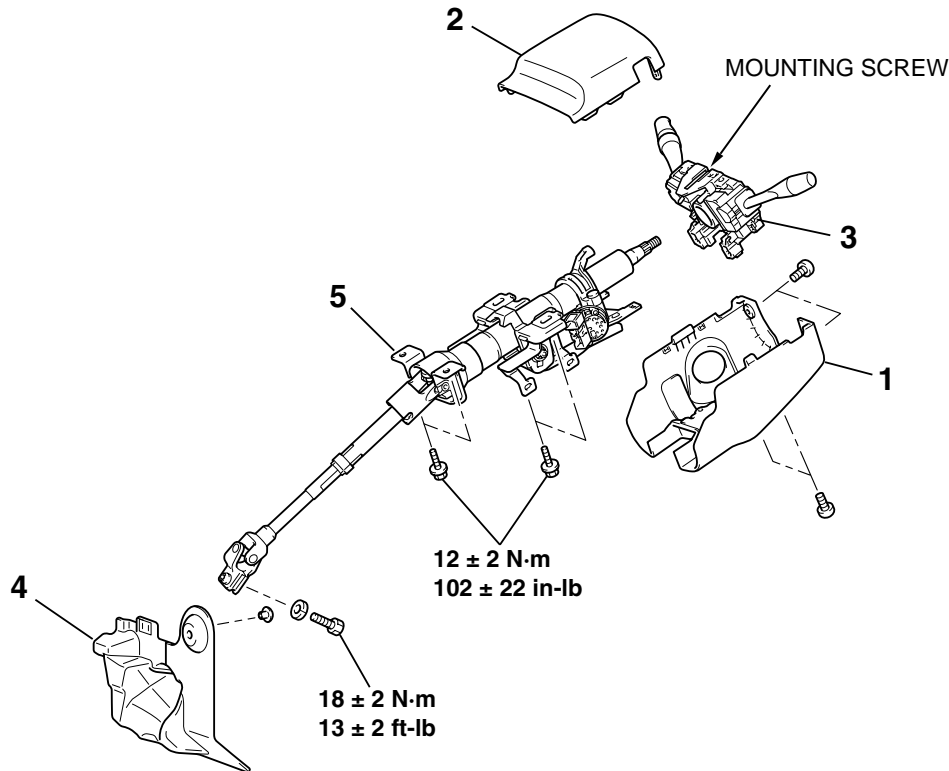

AC306562 AB

REMOVAL STEPS

1. STEERING COLUMN LOWER COVER
2. STEERING COLUMN UPPER COVER
3. CLOCK SPRING AND COLUMN SWITCH ASSEMBLY (REFER TO GROUP 52B, AIR BAG MODULE AND CLOCK SPRING P.52B-369).

REMOVAL STEPS (Continued)

- KEY INTERLOCK CABLE CONNECTION (REFER TO GROUP 23, AT KEY INTERLOCK AND SHIFT LOCK MECHANISM P.23A-385).
4. STEERING SHAFT PAD
 5. STEERING COLUMN ASSEMBLY

<<A>> >>A<<

REMOVAL SERVICE POINT

<<A>> STEERING COLUMN ASSEMBLY
REMOVAL

⚠ CAUTION

The tilt lever should be held in the lock position until the steering column assembly is installed to the vehicle. If the steering column assembly is removed with the tilt lever released, or the tilt lever is released after the steering column assembly was removed from the vehicle, the steering column assembly cannot be reinstalled correctly. If the steering column assembly is installed incorrectly, the collision energy absorbing mechanism may be damaged.

1. Ensure that the tilt lever is in the lock position, and remove the steering column assembly mounting bolts.
2. Pinch the steering column shaft clip with pliers, and pull up the shaft in the direction shown to disengage the steering column assembly.

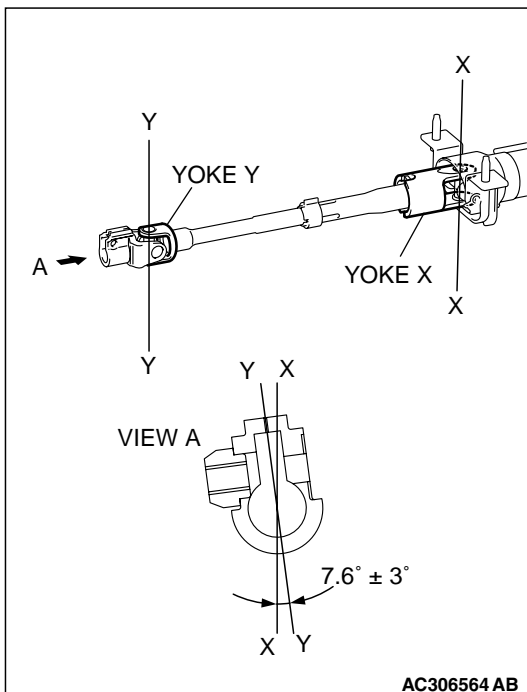
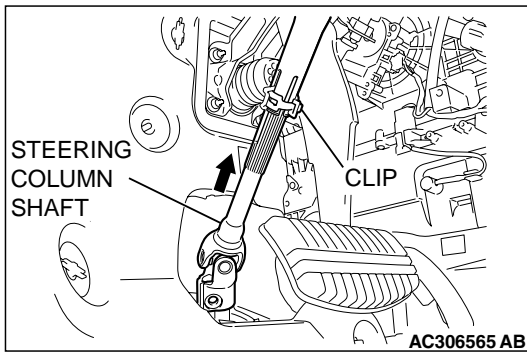

NOTE: If the steering column shaft is removed accidentally, remove the steering column assembly and be sure to insert the steering column shaft into the steering column as shown in the figure.

INSTALLATION SERVICE POINT

>>A<< STEERING COLUMN ASSEMBLY INSTALLATION

⚠ CAUTION

1. If reusing the steering column assembly, do not release the tilt lever until the steering column assembly has been installed.
2. If a new steering column assembly is being installed, do not release the tilt lever until it has been installed. Do not remove the tilt lever fixing band until the installation is completed.
3. When installing the steering column assembly, do not leave it fixed temporarily at only one point and make sure the steering column assembly is not shaken strongly. If this happens, the collision absorbing mechanism at the steering column assembly mounting location may be damaged.

Ensure that the tilt lever is in the lock position, and install the steering column assembly. Tighten the four bolts finger-tight in the order shown, and then tighten them to the specified torque in the order shown.

Tightening torque: 12 ± 2 N·m (102 ± 22 in-lb)

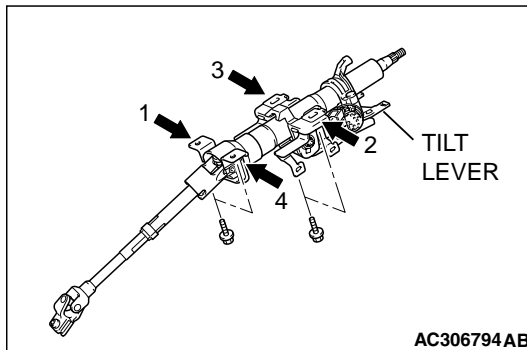

DISASSEMBLY AND ASSEMBLY

M1372011700117

⚠ WARNING

Do not move the tilt lever from the lock position until the installation is completed. If you move it accidentally, the steering column cannot be reinstalled correctly.

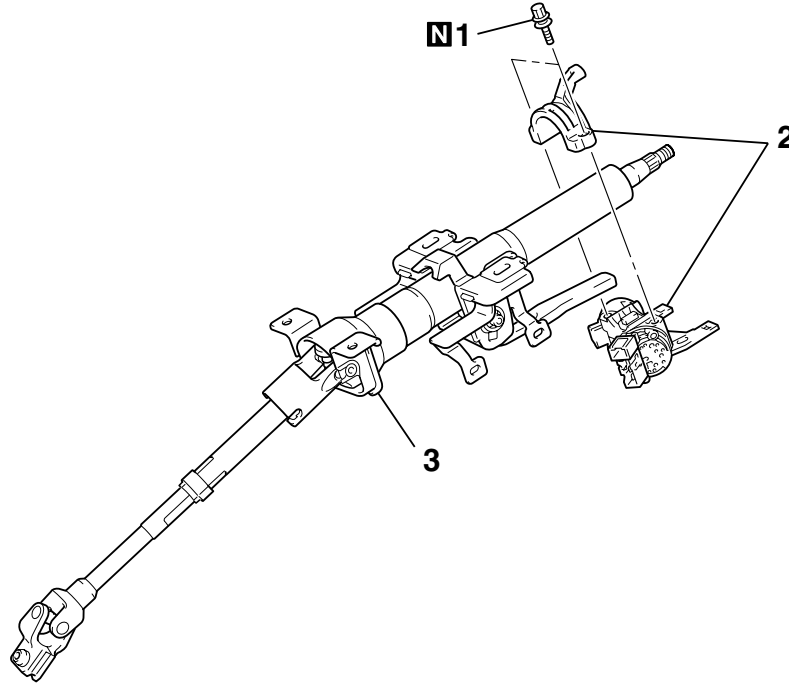

AC306566 AB

<<A>> >>A<< 1. **DISASSEMBLY STEPS**
STEERING LOCK BOLT

>>A<< 2. **DISASSEMBLY STEPS (Continued)**
ENGINE STARTING SWITCH
ASSEMBLY
3. STEERING COLUMN ASSEMBLY

DISASSEMBLY SERVICE POINT

<<A>> STEERING LOCK BOLT REMOVAL

1. Drill in the steering lock bolt a hole deep enough for the tap to stand.
2. Remove the steering lock bolt with a left-hand tap.

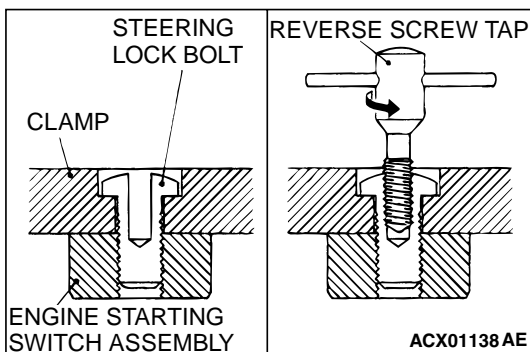

ASSEMBLY SERVICE POINT

>>A<< ENGINE STARTING SWITCH ASSEMBLY/STEERING LOCK BOLT INSTALLATION

⚠ CAUTION

The bolts must be replaced with new ones when the steering lock is installed.

1. When installing the engine starting switch assembly to the steering column assembly, temporarily install the engine starting switch assembly in alignment with the column boss.
2. After checking that the lock works properly, tighten the steering lock bolts until the head is twisted off.

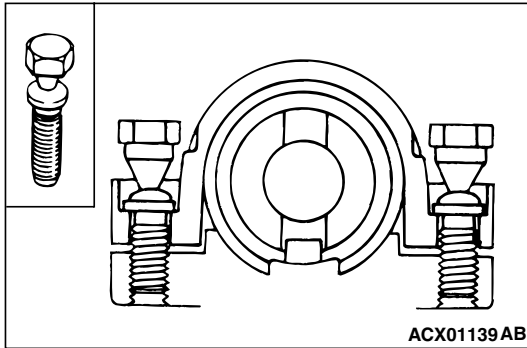

POWER STEERING GEAR BOX AND LINKAGE

REMOVAL AND INSTALLATION

M1372010900259

⚠ WARNING

- Before removing the power steering gear assembly, refer to **GROUP 52B, Service Precautions and Air Bag Module and Clock Spring (P.52B-26 and P.52B-369)**.
- Center the front wheels. Failure to do so may damage the SRS clock spring and render the SRS system inoperative, risking serious injury.

⚠ CAUTION

* : Indicates parts which should be temporarily tightened, and then fully tightened after placing the vehicle horizontally and loading the full weight of the engine on the vehicle body.

Pre-removal Operation

- Power Steering Fluid Draining (Refer to [P.37-21](#)).
- Front Under Cover Removal
- Centermember Removal (Refer to **GROUP 32, Engine Roll Stopper and Centermember P.32-7**).
- Lower Arm Assembly Removal (Refer to **GROUP 33, Lower Arm P.33-15**).
- Air Bag Module and Steering Wheel Assembly Removal (Refer to [P.37-26](#)).
- Floor Console Assembly Removal (Refer to **GROUP 52A, Floor Console Assembly P.52A-9**).
- Front Scuff Plate and Cowl Side Trim Removal (Refer to **GROUP 52A, Trims P.52A-10**).
- Trunk Lid Opener Cover Removal
- Accelerator Pedal Stopper Removal
- Front Floor Carpet Removal
- Stabilizer Link and Stabilizer Bar Disconnection (Refer to **GROUP 33, Stabilizer Bar P.33-20**).

Post-installation Operation

- Check the dust cover for cracks or damage by pushing it with your finger.
- Stabilizer Link and Stabilizer Bar Connection (Refer to **GROUP 33, Stabilizer Bar P.33-20**).
- Front Floor Carpet Installation
- Accelerator Pedal Stopper Installation
- Trunk Lid Opener Cover Installation
- Front Scuff Plate and Cowl Side Trim Removal (Refer to **GROUP 52A, Trims P.52A-10**).
- Floor Console Assembly Installation (Refer to **GROUP 52A, Floor Console Assembly P.52A-9**).
- Steering Wheel Assembly and Air Bag Module Installation (Refer to [P.37-26](#)).
- Checking Steering Wheel Position with Wheels Straight Ahead.
- Lower Arm Assembly Installation (Refer to **GROUP 33, Lower Arm P.33-15**).
- Centermember Installation (Refer to **GROUP 32, Engine Roll Stopper and Centermember P.32-7**).
- Front Under Cover Installation
- Front Wheel Alignment Adjustment (Refer to **GROUP 33, On-vehicle Service – Front Wheel Alignment Check and Adjustment P.33-6**).
- Power Steering Fluid Supplying (Refer to [P.37-21](#)).
- Power Steering Fluid Line Bleeding (Refer to [P.37-21](#)).

**POWER STEERING
POWER STEERING GEAR BOX AND LINKAGE**

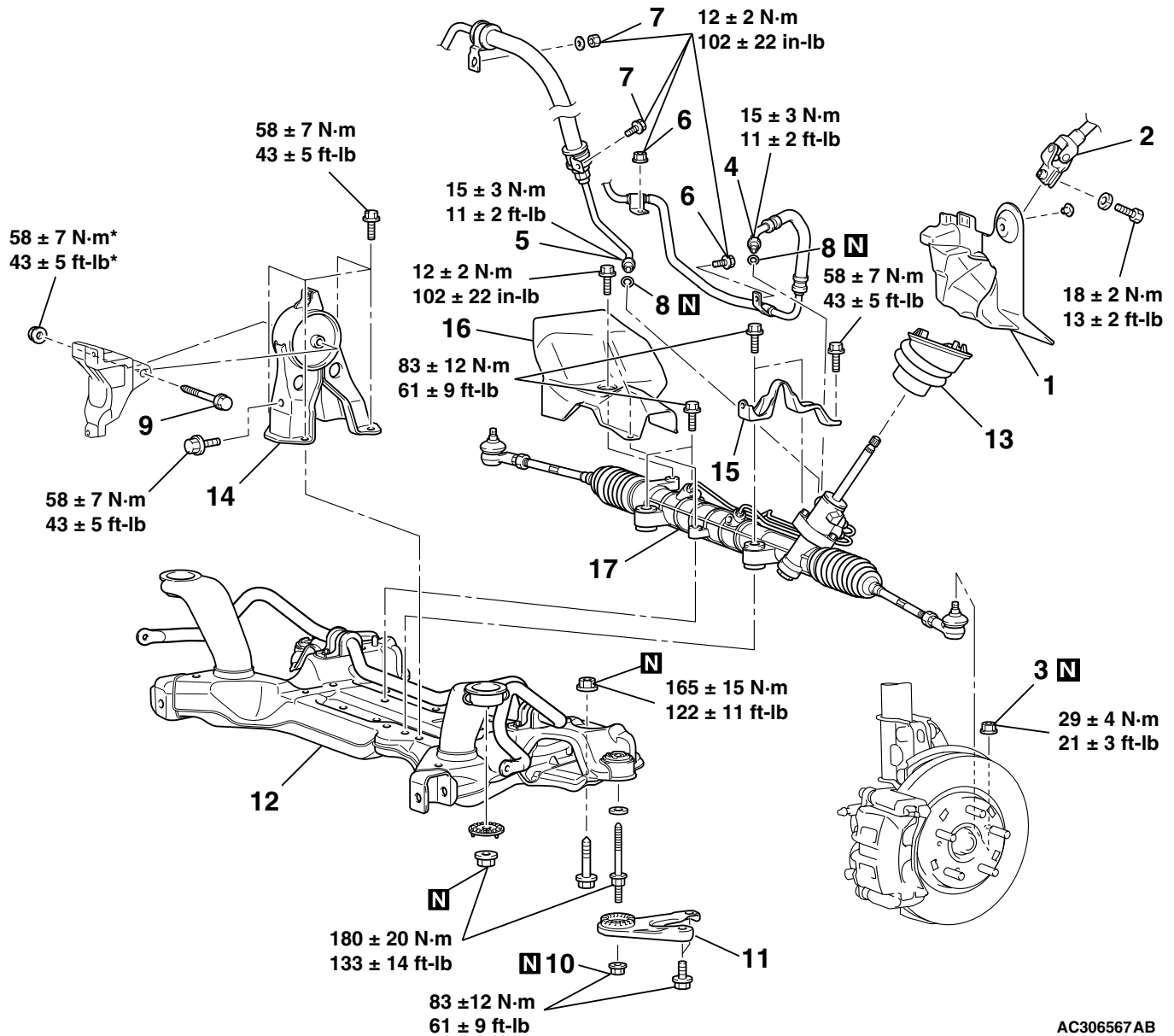

AC306567AB

REMOVAL STEPS

- <<A>> 1. STEERING SHAFT PAD
- <<A>> 2. STEERING COLUMN ASSEMBLY AND STEERING GEAR CONNECTION
- <> 3. SELF LOCKING NUT (TIE ROD END AND KNUCKLE CONNECTION)
- <> 4. RETURN TUBE CONNECTION
- <> 5. PRESSURE HOSE CONNECTION
- <> 6. RETURN TUBE CLAMP
- <> 7. PRESSURE HOSE CLAMP
- <> 8. O-RING
- <> 9. REAR ROLL STOPPER CONNECTING BOLT
- >>C<< 10. SELF LOCKING NUT

REMOVAL STEPS (Continued)

- <<C>> >>C<< 11. FRONT AXLE CROSSMEMBER STAY
- <<D>> >>B<< 12. CROSSMEMBER ASSEMBLY
- >>B<< 13. STEERING COLUMN DASH PANEL COVER
- >>A<< 14. REAR ROLL STOPPER
- >>A<< 15. POWER STEERING GEAR BRACKET
- 16. STEERING GEAR AND LINKAGE PROTECTOR <3.8L ENGINE>
- 17. POWER STEERING GEAR AND LINKAGE

Required Special Tool:

- MB991897: Ball Joint Remover

REMOVAL SERVICE POINTS

<<A>> STEERING COLUMN ASSEMBLY AND
STEERING GEAR DISCONNECTION

1. Pinch the steering column shaft clip with pliers, and pull up the shaft in the direction shown to disengage the steering column assembly.

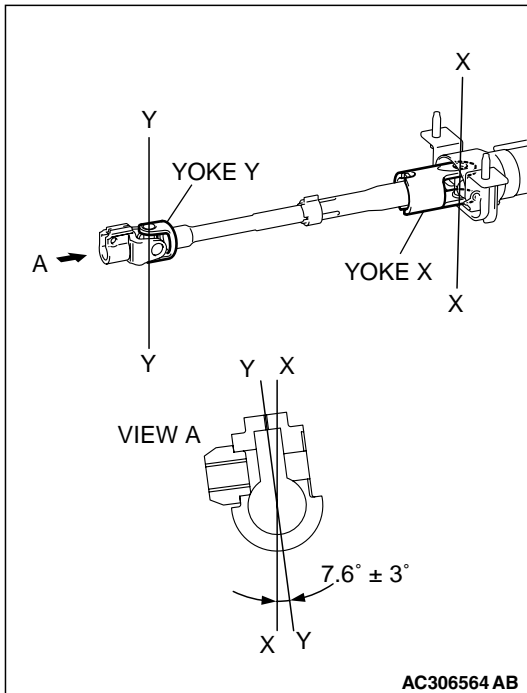
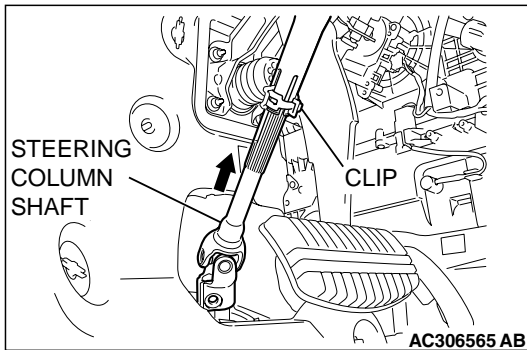

<> TIE ROD END AND KNUCKLE
DISCONNECTION**⚠ CAUTION**

- Do not remove the nut from ball joint. Loosen it and use special tool MB991897 to avoid possible damage to ball joint threads.
- Hang special tool MB991897 with a cord to prevent it from falling.

1. Install special tool MB991897 as shown in the figure.

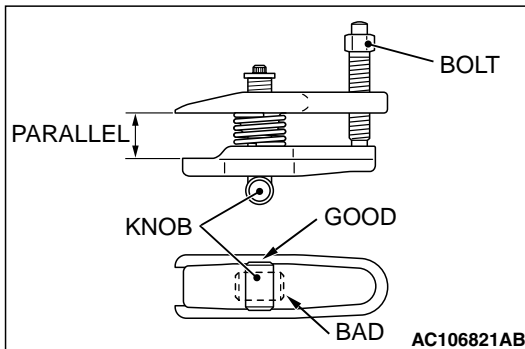
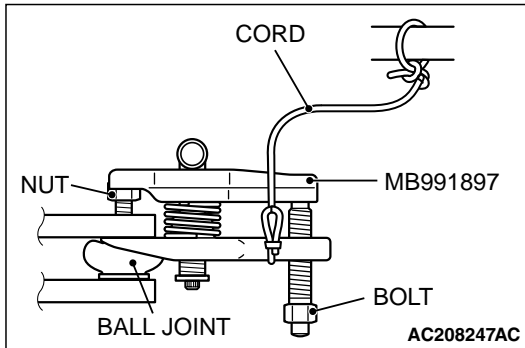

2. Turn the bolt and knob as necessary to make the jaws of special tool MB991897 parallel, tighten the bolt by hand and confirm that the jaws are still parallel.

NOTE: When adjusting the jaws in parallel, make sure the knob is in the position shown in the figure.

3. Tighten the bolt with a wrench to disconnect the tie rod end.

<<C>> FRONT AXLE CROSSMEMBER STAY
REMOVAL

The crossmember mounting bolts need not be unscrewed when the front axle crossmember stay is replaced. However, the bolts may be loose while the front axle crossmember stay is removed. Retighten the bolts to 180 ± 20 N·m (133 ± 14 ft-lb).

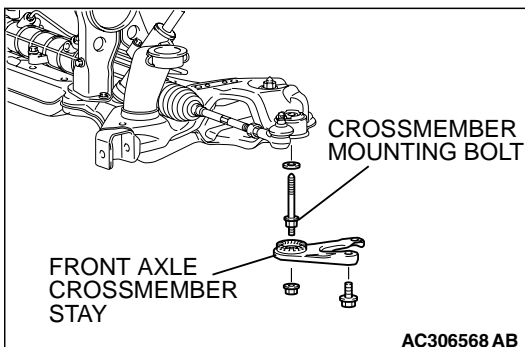

<<D>> CROSSMEMBER ASSEMBLY REMOVAL

1. From inside the vehicle, loosen the 3 shown clips from the body panel.

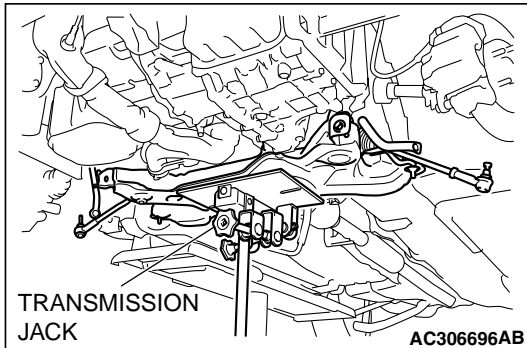
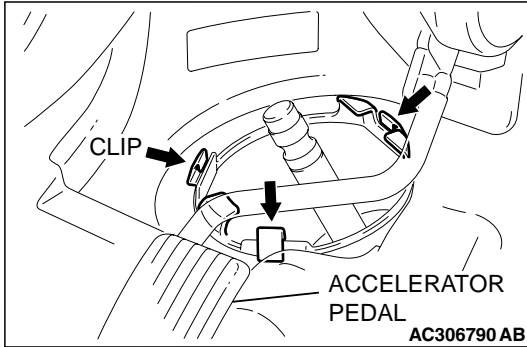

2. Use a transmission jack to hold the crossmember, and then remove the crossmember mounting nuts and bolts.
3. Lower the crossmember with the rear roll stopper, the stabilizer bar and the steering gear.

INSTALLATION SERVICE POINTS

>>A<< POWER STEERING GEAR
BRACKET/REAR ROLL STOPPER INSTALLATION

Tighten the bolts as follows:

1. Tighten the bolt A and then tighten the bolt B.
2. Tighten the bolts E with finger tight.
3. Tighten the bolt C and then tighten the bolts D.
4. Tighten the bolts E and then tighten the bolt F.

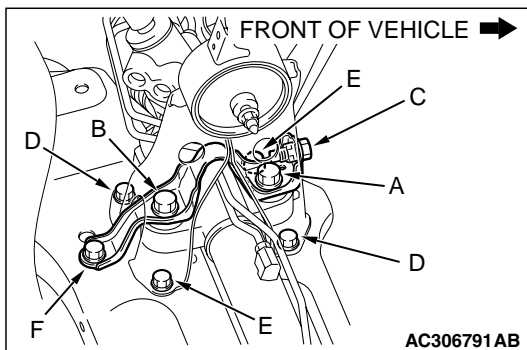

>>B<< STEERING COLUMN DASH PANEL
COVER/CROSSMEMBER ASSEMBLY
INSTALLATION

1. Align the steering column dash panel cover notch (arrow A) with the steering gear lug (arrow B), and then install the steering column dash panel cover to the steering gear.

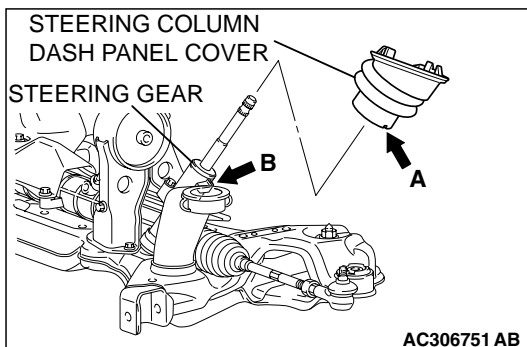

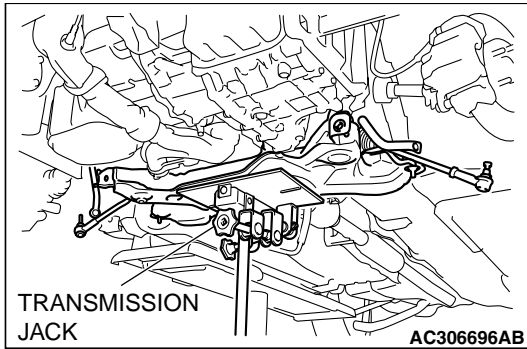

2. Use a transmission jack to lift the crossmember assembly.

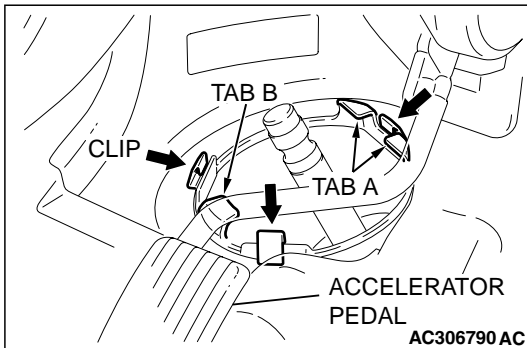

3. From inside the vehicle, pull tab A and then tab B to secure the three clips to the body panel.

NOTE:

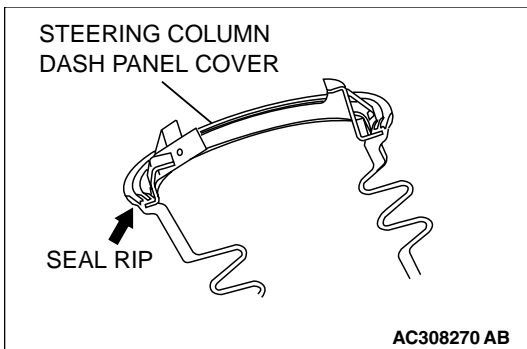

When securing the steering column dash panel cover to the body panel, be careful that the seal lip does not move backwards.

4. Check that it has been secured by pressing down the tip of the clips by your finger. Also check that the steering column dash panel cover is installed securely to the steering gear.

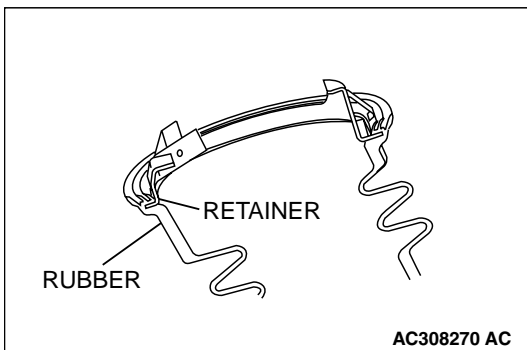

5. After installing the steering column dash panel cover, check that the steering column dash panel cover rubber is not disengaged from the retainer. If there is any doubt, release the clips from the body, engage the rubber again and reinstall to the body.
6. Tighten the crossmember mounting nuts and bolts.

>>C<< FRONT AXLE CROSSMEMBER STAY/SELF-LOCKING NUT INSTALLATION

Ensure that the crossmember mounting bolts have been tightened to 180 ± 20 N·m (133 ± 14 ft·lb), and then install the front crossmember stay with the self-locking nut.

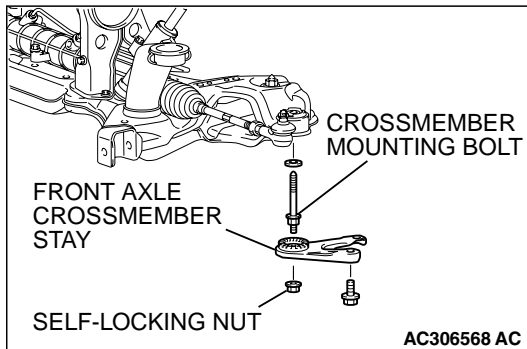

INSPECTION

M1372011000259

STEERING GEAR TOTAL PINION TORQUE CHECK

Required Special Tool:

- MB991006: Preload Socket

⚠ CAUTION

- When holding the steering gear in a vice, secure its mounting positions. If it is secured in any other place, the gear housing may become deformed or damaged.
- Do not loosen the adjust screw more than 2 rotations.
- If the adjust screw is loosened more than 2 rotations, or if it is removed, replace the steering gear assembly.

1. Using special tool MB991006, rotate the pinion gear at the rate of one rotation in approximately 4 to 6 seconds to check the total pinion torque.

Standard value: 0.8 – 1.9 N·m (7.1 – 16.8 in·lb)
[Change in torque: 0.7 N·m (6.2 in·lb) or less]

NOTE: When measuring, remove the bellows from the rack housing. Measure the pinion torque through the whole stroke of the rack.

2. If the total pinion torque or the change in torque is outside the standard value, loosen the rack support cover once and retighten it to the specified torque 12 ± 2 N·m (107 ± 17 in·lb). And then loosen the rack support cover 10 degrees, and check the pinion torque again.

If the total pinion torque cannot be adjusted to within the standard range by adjusting the rack support cover, replace the power steering gear.

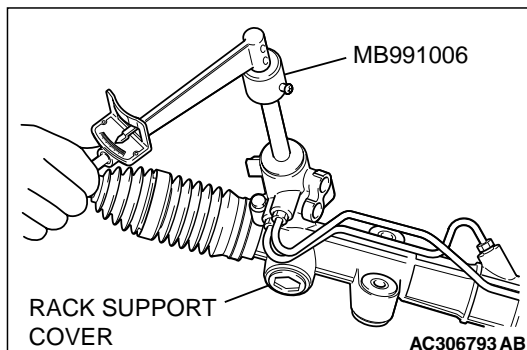

TIE ROD SWING RESISTANCE CHECK

1. Give 10 hard swings to the tie rod.
2. Measure the tie rod swing resistance with a spring scale.

Standard value:

3.7 – 18.1 N (0.83 – 4.07 lb) <vehicles with 16-inch wheels>

3.6 – 17.8 N (0.81 – 4.00 lb) <vehicles with 17-inch wheels>

[Swing torque: 1.0 – 4.9 N·m (8.9 – 43.3 in-lb)]

3. If the measured value exceeds the standard value, replace the tie rod.
4. If the measured value is below the standard value, the tie rod can be re-used if it swings smoothly without excessive play.

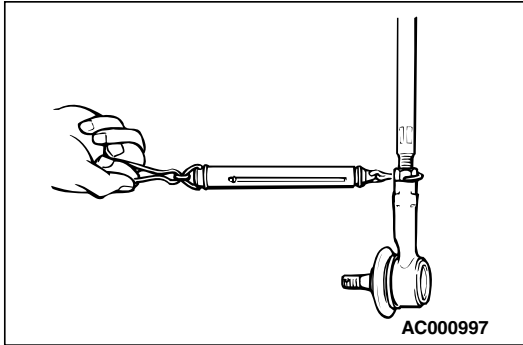
**TIE ROD END BALL JOINT DUST COVER CHECK**

1. Check the dust cover for cracks or damage by pushing it with your finger.
2. If the dust cover is cracked or damaged, replace the tie rod end. (Refer to [P.37-41](#)).

DISASSEMBLY AND ASSEMBLY

M1372011100223

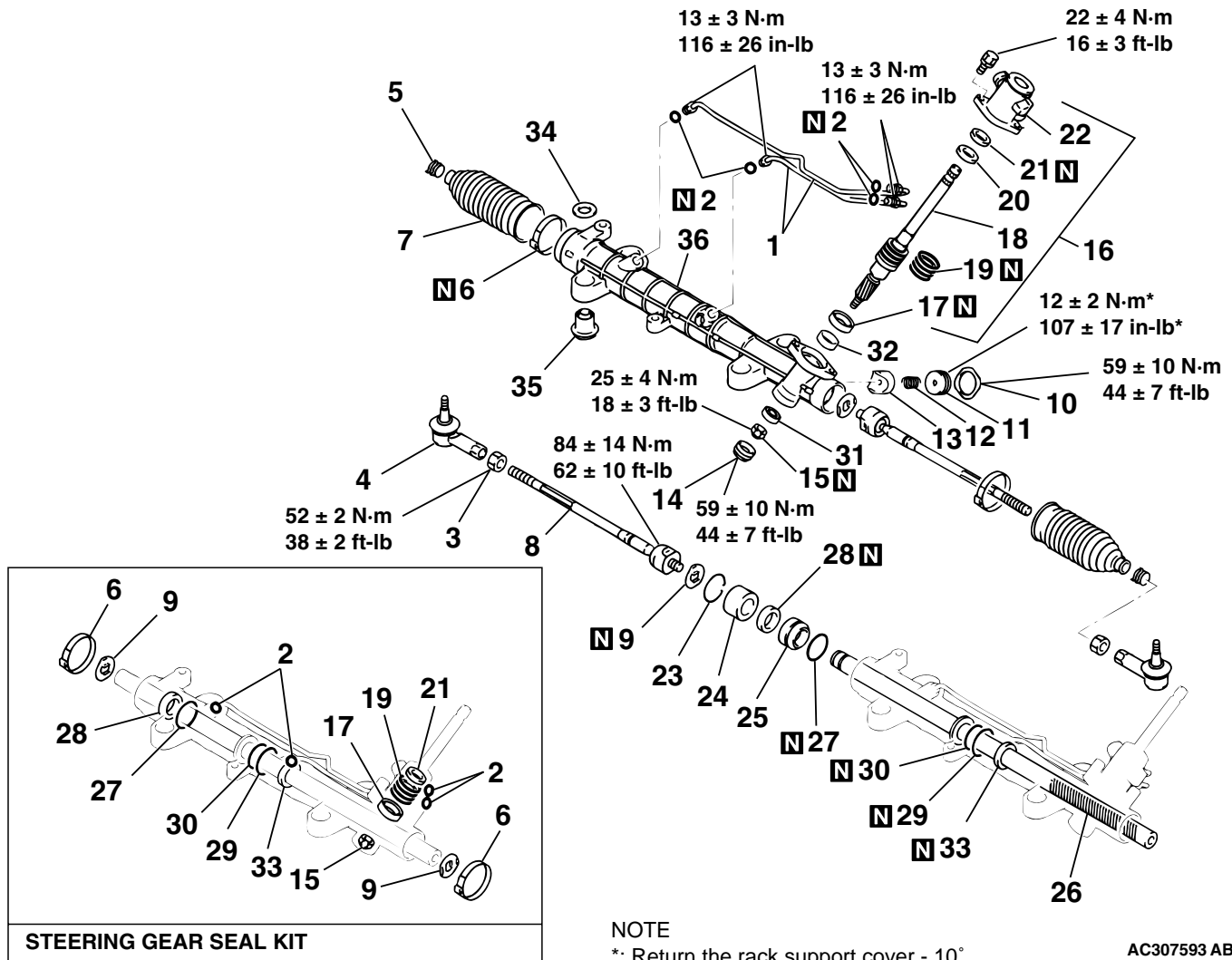

NOTE

*: Return the rack support cover - 10°.

AC307593 AB

DISASSEMBLY STEPS

1. P/S OIL FEED TUBE ASSEMBLY
2. STEERING GEAR INNER O-RING
- >>P<< 3. STEERING GEAR NUT (TIE ROD END JAM NUT)
- >>P<< 4. TIE ROD END ASSEMBLY
5. STEERING GEAR INNER CLIP
- >>O<< 6. STEERING GEAR BAND (BELLOWS BAND)
7. STEERING GEAR BELLOWS
- <<A>> >>N<< 8. STEERING TIE ROD
- <<A>> >>N<< 9. STEERING GEAR WASHER (TAB WASHER)
- >>M<< • TOTAL PINION TORQUE ADJUSTMENT
- >>L<< 10. STEERING GEAR INNER NUT (JAM NUT)
- <> >>L<< 11. STEERING GEAR RACK SUPPORT COVER
12. STEERING GEAR RACK SUPPORT SPRING
13. STEERING GEAR RACK SUPPORT

DISASSEMBLY STEPS (Continued)

- >>K<< 14. STEERING GEAR PLUG (END PLUG)
15. STEERING GEAR INNER NUT
16. VALVE ASSEMBLY
- <<C>> >>J<< 17. OIL SEAL
- <<C>> 18. PINION AND VALVE ASSEMBLY
- <<D>> >>K<< 19. SEAL RING
- <<E>> >>H<< 20. SPECIAL BEARING
- <<E>> >>H<< 21. OIL SEAL
22. VALVE HOUSING
- <<F>> >>G<< 23. STEERING GEAR PISTON CLIP (CIRCLIP)
24. STEERING GEAR RACK STOPPER
- >>F<< 25. STEERING GEAR BUSHING (RACK BUSHING)
- <<G>> >>E<< 26. STEERING GEAR RACK
- >>D<< 27. O-RING
- <<H>> >>D<< 28. OIL SEAL
29. PISTON RING
30. O-RING
- <<D>> >>C<< 31. STEERING GEAR PINION BEARING (BALL BEARING)

DISASSEMBLY STEPS (Continued)

- <<J>> >>C<< 32. STEERING GEAR PINION SHAFT
UPPER BEARING (NEEDLE
ROLLER BEARING)
- <<K>> >>B<< 33. OIL SEAL
34. STEERING GEAR CUSHION
- <<L>> >>A<< 35. STEERING GEAR BUSHING
36. RACK HOUSING

Required Special Tools:

- MB990927: Installer Adapter
- MB990938: Bar (Snap-in type)
- MB990939: Brass Bar
- MB990996: Lower Arm Bushing Arbor
- MB991006: Preload Socket
- MB991120: Needle Bearing Puller
- MB991152: Dust Cover Installer
- MB991197: Bar (Long type)
- MB991199: Oil Seal Installer
- MB991202: Oil Seal and Bearing Installer
- MB991203: Oil Seal and Bearing Installer
- MB991204: Torque Wrench Socket
- MB991213: Rack Installer
- MB991317: Seal Ring Installer
- MB991561: Boot Band Crimping Tool
- MD998812: Installer Cap
- MD998813: Installer 100
- MD998822: Installer Adapter
- MD998368: Bearing Installer
- MD999569: Camshaft Oil Seal Installer

LUBRICATION AND SEALING POINTS

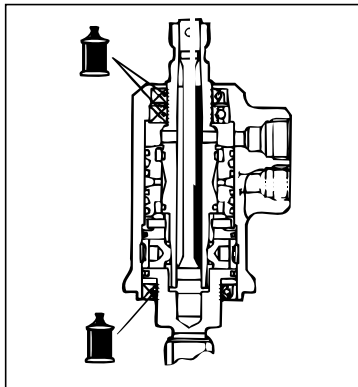

FLUID:
GENUINE MITSUBISHI
POWER STEERING FLUID

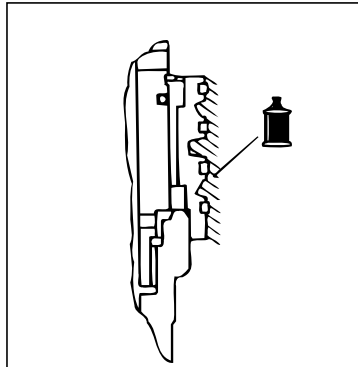

FLUID:
GENUINE MITSUBISHI
POWER STEERING FLUID

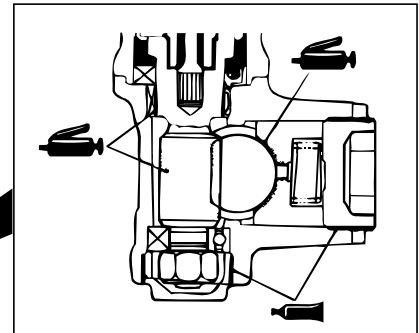

SEALANT:
3M™ AAD PART NO. 8661,
8663, 8672, 8678, 8679 OR
EQUIVALENT

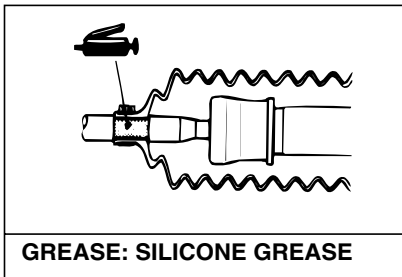
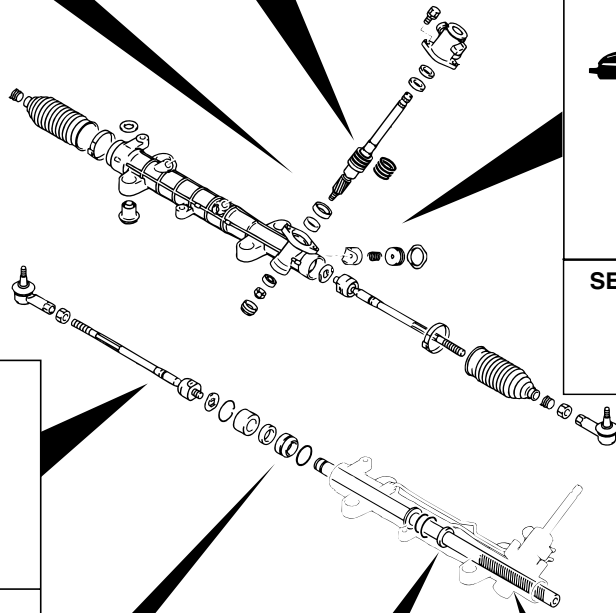

GREASE: SILICONE GREASE

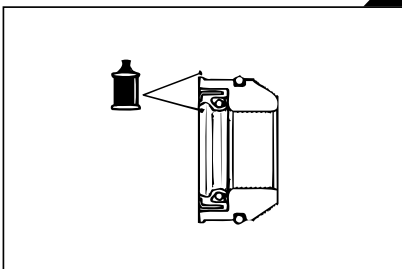

FLUID:
GENUINE MITSUBISHI POWER
STEERING FLUID

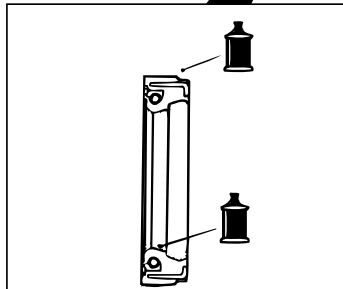

FLUID:
GENUINE MITSUBISHI
POWER STEERING FLUID

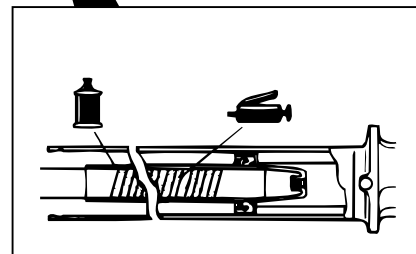

FLUID:
GENUINE MITSUBISHI POWER
STEERING FLUID

DISASSEMBLY SERVICE POINTS**<<A>> STEERING TIE ROD/STEERING GEAR
WASHER (TAB WASHER) REMOVAL**

Unstake the tab washer which secures the tie rod and rack with a chisel.

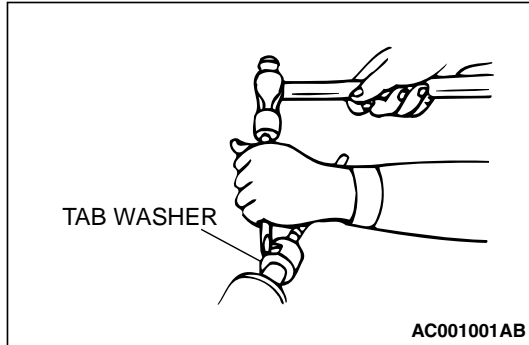
**<> STEERING GEAR RACK SUPPORT
COVER REMOVAL**

Using special tool MB991204, remove the rack support cover from the gear box.

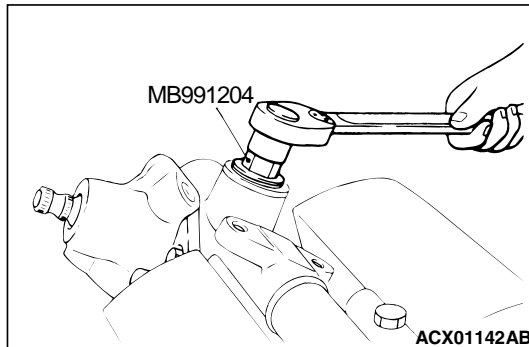
**<<C>> OIL SEAL/PINION AND VALVE ASSEMBLY
REMOVAL**

Using a plastic hammer, gently tap the pinion to remove it.

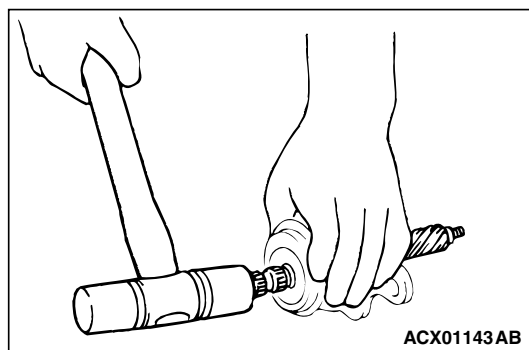

<<D>> SEAL RING REMOVAL

⚠ CAUTION

When cutting the seal ring, be careful not to damage the pinion and valve assembly or the rack.

Cut the seal ring and remove it from the pinion and valve assembly and the rack.

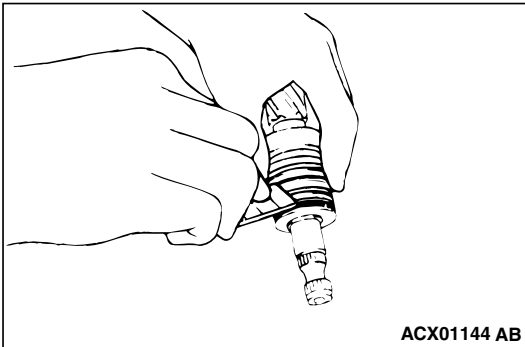

<<E>> SPECIAL BEARING/OIL SEAL REMOVAL

Using a socket, remove the oil seal and the special bearing from the valve housing simultaneously.

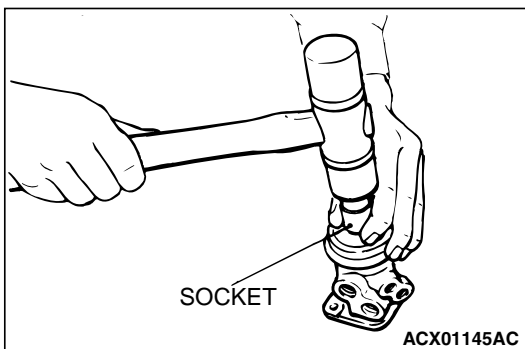

<<F>> STEERING GEAR PISTON CLIP (CIRCLIP) REMOVAL

⚠ CAUTION

If the rack stopper is first turned counterclockwise, the circlip will get caught in the slot in the housing and the rack stopper will not turn.

1. Turn the rack stopper clockwise until the end of the circlip comes out of the slot in the rack housing.
2. Turn the rack stopper counterclockwise to remove the circlip.

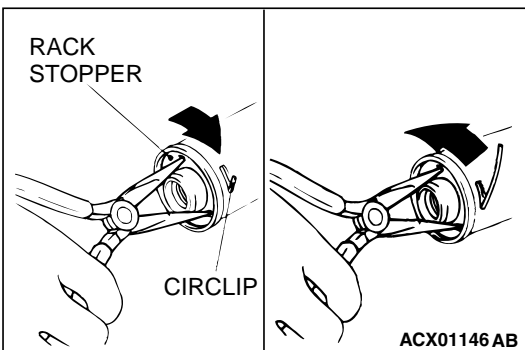

<<G>> STEERING GEAR RACK REMOVAL

Pull out the rack slowly. Take out the rack stopper and the rack bushing at the same time.

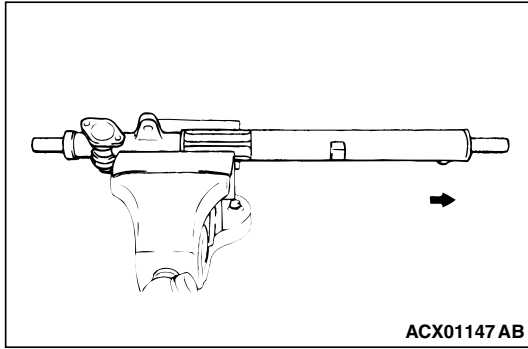

<<H>> OIL SEAL REMOVAL

CAUTION

Do not damage oil seal press fitting surface.

Partially prize the oil seal and remove it from the rack bushing.

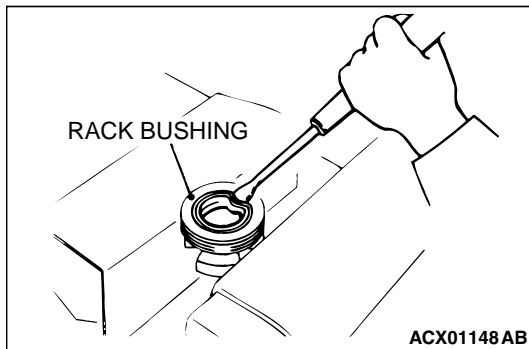

<<I>> STEERING GEAR PINION BEARING (BALL BEARING) REMOVAL

Use a brass bar or special tool MB990939 to remove the ball bearing from the gear housing.

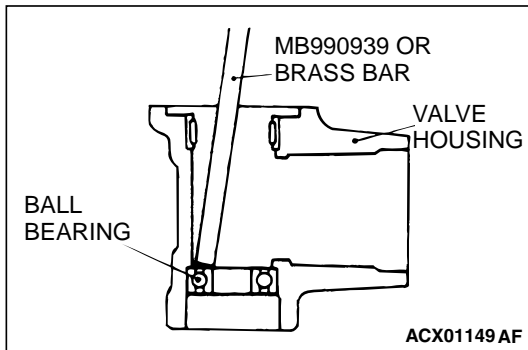

<<J>> STEERING GEAR PINION SHAFT UPPER BEARING (NEEDLE ROLLER BEARING) REMOVAL

⚠ CAUTION

Do not open special tool MB991120 excessively to prevent damaging housing interior.

Use special tool MB991120 to remove the needle roller bearing from the rack housing.

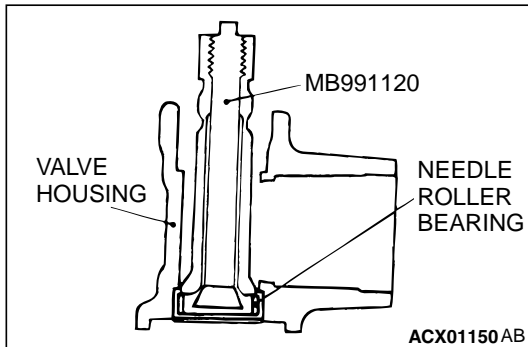

<<K>> OIL SEAL REMOVAL

⚠ CAUTION

Be careful not to damage the inner surface of the rack cylinder of the gear housing.

Use a piece of pipe or similar tool to remove the oil seal from the gear housing.

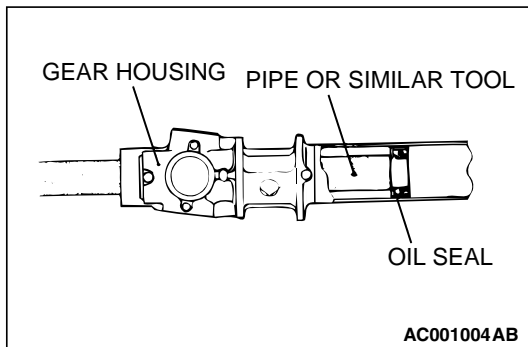

<<L>> STEERING GEAR BUSHING REMOVAL

Use special tools MD998812, MD998813, MD998822 and MD998368 to remove the steering gear bushing.

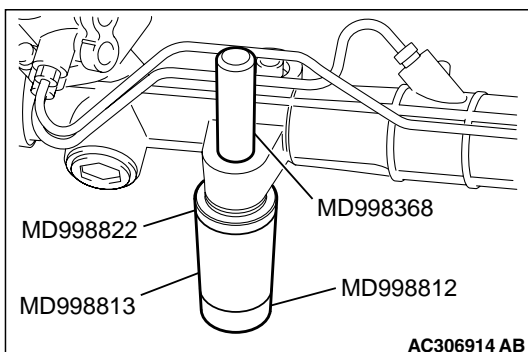

ASSEMBLY SERVICE POINTS

>>A<< STEERING GEAR BUSHING INSTALLATION

Use special tools MD999569 and MB990996 to press fit the steering gear bushing. The projections of the bushing should be positioned as illustrated.

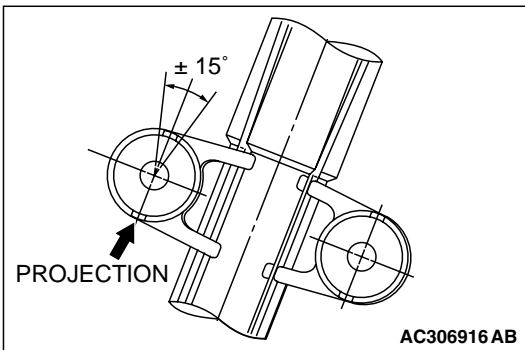
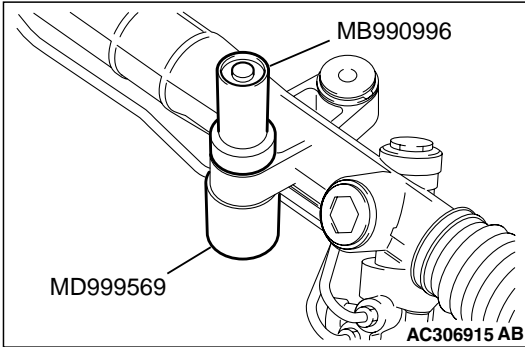

>>B<< OIL SEAL INSTALLATION

1. Apply a coating of GENUINE MITSUBISHI POWER STEERING FLUID to the both sides of the oil seal.
2. Using special tools MB991199 and MB991197, press the oil seal into the rack housing.

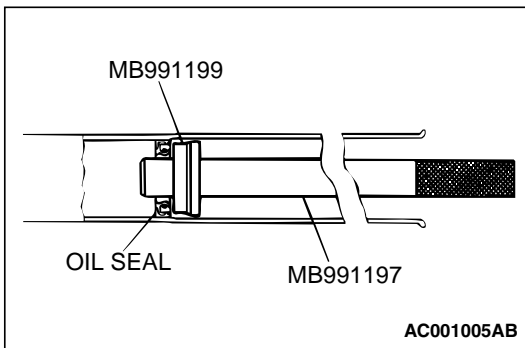

>>C<< STEERING GEAR PINION SHAFT UPPER BEARING (NEEDLE ROLLER BEARING)/STEERING GEAR PINION BEARING (BALL BEARING) INSTALLATION

⚠ CAUTION

Press-fit the bearing straight. The valve housing is aluminum, and may become deformed if the bearing is press-fitted on an angle.

1. Apply GENUINE MITSUBISHI POWER STEERING FLUID to the housing, bearing and oil seal press fitting surface.
2. Press fit the needle roller bearing with special tools MB990938 and MB991202.

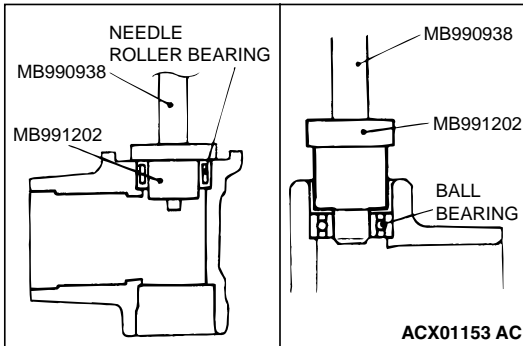

>>D<< OIL SEAL/O-RING INSTALLATION

1. Apply a coating of GENUINE MITSUBISHI POWER STEERING FLUID to the outside of the oil seal and O-ring.
2. Use special tool MB990927 to press fit oil seal until it touches the rack bush end.

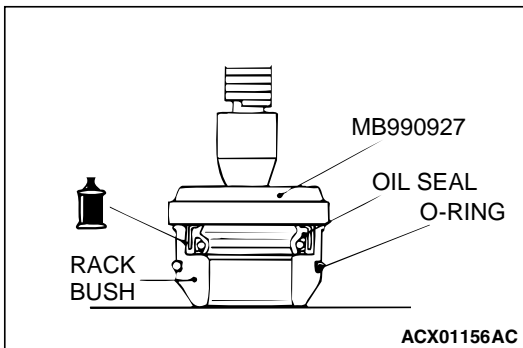

>>E<< STEERING GEAR RACK INSTALLATION

⚠ CAUTION

Do not close the vent hole in the rack with grease.

1. Apply a coating of multipurpose grease to the rack teeth face.

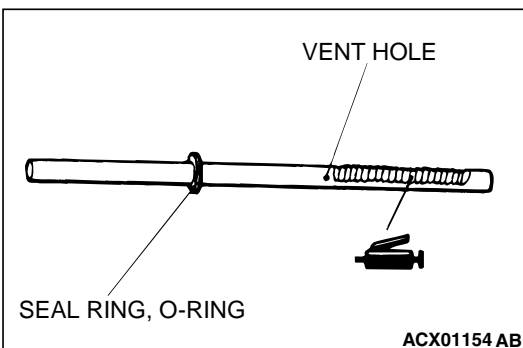

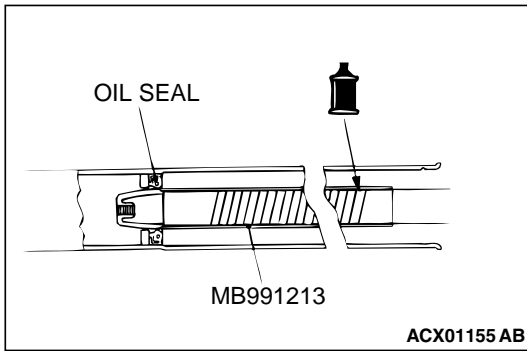

2. Cover the rack serrations with special tool MB991213.
3. Apply GENUINE MITSUBISHI POWER STEERING FLUID to special tool MB991213.
4. Align the center of the oil seal with the rack to prevent the retainer spring from slipping. Slowly insert the rack from power the cylinder side.

>>F<< STEERING GEAR BUSHING (RACK BUSHING) INSTALLATION

⚠ CAUTION

Do not allow oil seal retainer spring to slip out.

Wrap the rack end with vinyl tape, apply a coating of GENUINE MITSUBISHI POWER STEERING FLUID, and then install the rack bushing and rack stopper.

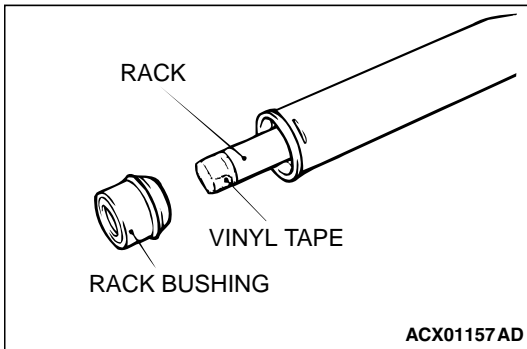

>>G<< STEERING GEAR PISTON CLIP (CIRCLIP) INSTALLATION

⚠ CAUTION

Insert the circlip to the rack stopper hole while turning the rack stopper clockwise.

Insert the circlip to the rack stopper hole through the cylinder hole. Turn the rack stopper clockwise and insert the circlip firmly.

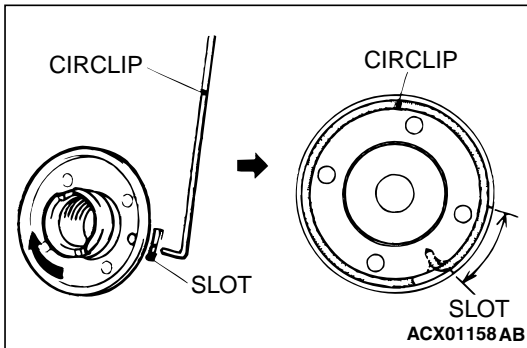

>>H<< OIL SEAL/SPECIAL BEARING INSTALLATION

Apply a coating of GENUINE MITSUBISHI POWER STEERING FLUID to the outside of the oil seal/special bearing. Using special tools MB990938 and MB991203, press the oil seal/special bearing into the valve housing.

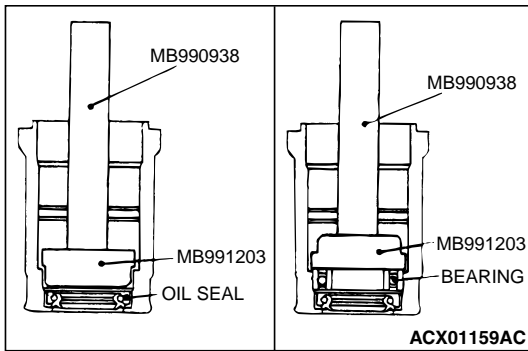

>>I<< SEAL RING INSTALLATION

Because the seal rings expand after installation, tighten after installing by using special tool MB991317 to compress the seal rings, or press down by hand.

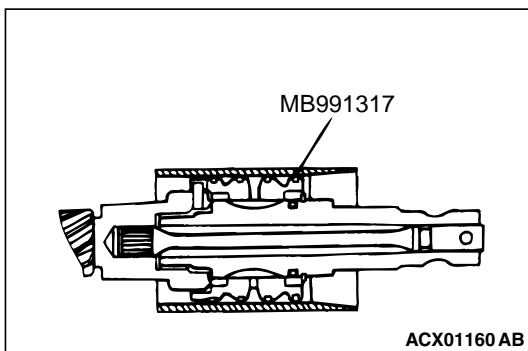

>>J<< OIL SEAL INSTALLATION

⚠ CAUTION

To eliminate a seal malfunction at the valve housing alignment surface, the upper surface of the oil seal should project outward approximately 1 mm (0.04 inch) from the housing edge surface.

Using special tool MB991152, press the oil seal into the valve housing.

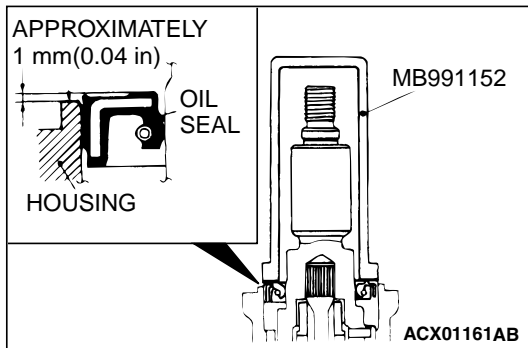

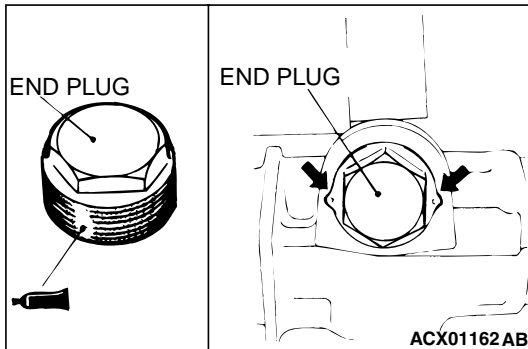
**>>K<< STEERING GEAR PLUG (END PLUG)
INSTALLATION**

1. Apply 3M™ AAD Part number 8661, 8663, 8672, 8678, 8679 or equivalent to the threaded part of the end plug.
2. Secure the threaded portion of the end plug at two places by using a punch.

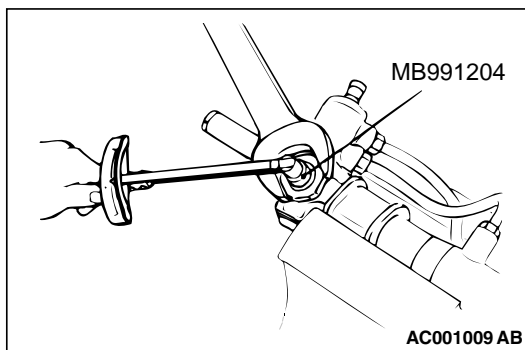
**>>L<< STEERING GEAR RACK SUPPORT
COVER/STEERING GEAR INNER NUT (JAM NUT)
INSTALLATION**

1. Position the rack at its center.
2. Apply 3M™ AAD Part number 8661, 8663, 8672, 8678, 8679 or equivalent to the threaded part of the rack support cover.
3. Use special tool MB991204 to tighten the rack support cover to 12 ± 2 N·m (107 ± 17 in-lb).
4. Turn the rack support cover 10 degree angle counterclockwise.
5. Use special tool MB991204 to hold the rack support cover, and then tighten the jam nut to 59 ± 10 N·m (44 ± 7 ft-lb).

>>M<< TOTAL PINION TORQUE ADJUSTMENT**⚠ CAUTION**

- Be sure there is no ratcheting or catching when operating the rack towards the shaft.
- Measure the total pinion torque through the whole stroke of the rack.

1. Using special tool MB991006, rotate the pinion shaft at the rate of one rotation in 4 to 6 seconds to check the total pinion torque and the change in torque.

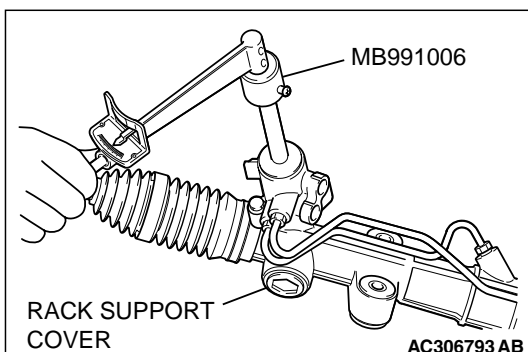
Standard value:**Total pinion torque: 0.8 – 1.9 N·m (7.1 – 16.8 in-lb)****[Change in torque: 0.7 N·m (6.2 in-lb) or less]**

⚠ CAUTION

When adjusting, set at the highest value of the standard value range.

NOTE: If the total pinion torque cannot be adjusted to the standard value within the standard range, replace the power steering gear and linkage assembly.

2. If the total pinion torque or the change in torque is outside the standard value, loosen the rack support cover once and retighten it to the specified torque 12 ± 2 N·m (107 ± 17 in-lb). And then loosen the rack support cover 10 degrees, and check the pinion torque again.

>>N<< STEERING GEAR WASHER (TAB WASHER)/STEERING TIE ROD INSTALLATION

After installing the tie rod to the rack, fold tab washer end (two locations) to tie rod notch.

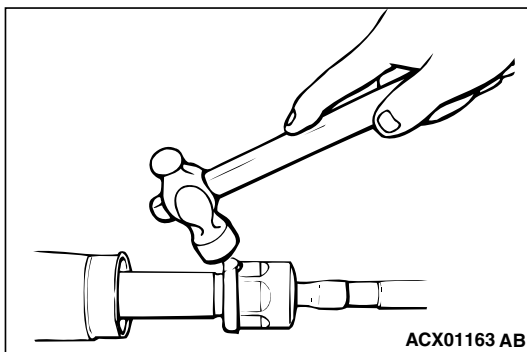

>>O<< STEERING GEAR BAND (BELLOWS BAND) INSTALLATION

1. Turn the adjusting bolt of special tool MB991561 to adjust the opening dimension (W) to the standard value.

NOTE: The dimension (W) is adjusted by approximately 0.7 mm (0.03 inch) per one turn.

NOTE: Do not turn the adjusting bolt more than one turn.

Standard value (W): 1.9 mm (0.07 inch)

<When more than 1.9 mm (0.07 inch)>: Screw in the adjusting bolt.

<When less than 1.9 mm (0.07 inch)>: Loosen the adjusting bolt.

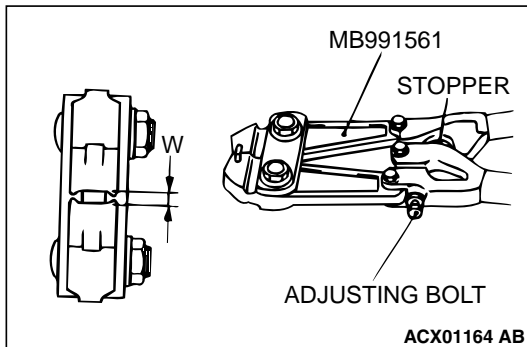

⚠ CAUTION

- Hold the rack housing, and use special tool MB991561 to crimp the bellows band securely.
 - Crimp the bellows band until special tool MB991561 touches the stopper.
2. Use special tool MB991561 to crimp the bellows band.

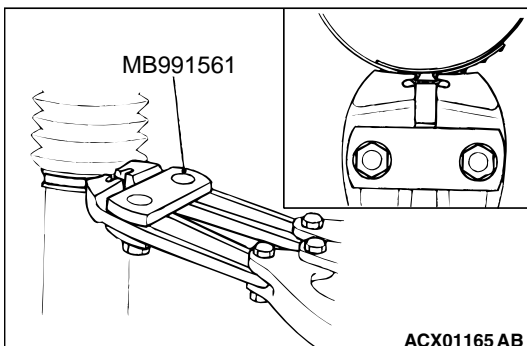

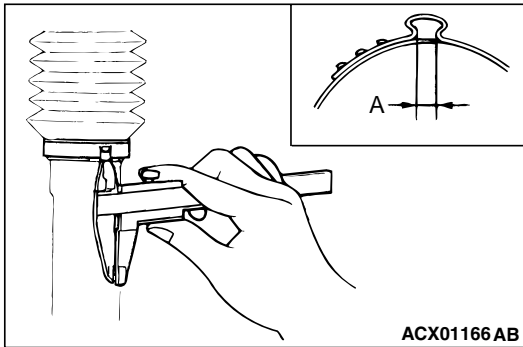

3. Check that crimped width (A) is within the standard value.
Standard value (A): 1.4 – 1.8 mm (0.06 – 0.07 inch)
<When more than 1.8 mm (0.07 inch)>: Readjust the dimension (W) of step (1) to the value calculated by the following equation, and repeat step (2).
 $W = 5.5 \text{ mm (0.22 inch)} - A$ [Example: if (A) is 1.9 mm (0.07 inch), (W) is 3.6 mm (0.14 inch).]
<When less than 1.4 mm (0.06 inch)>: Remove the bellows band, readjust the dimension (W) of step (1) to the value calculated by the following equation, and use a new bellows band to repeat steps (2) to (3).
 $W = 5.5 \text{ mm (0.22 inch)} - A$ [Example: if (A) is 1.3 mm (0.05 inch), (W) is 4.2 mm (0.17 inch).]

>>P<< TIE ROD END ASSEMBLY/STEERING GEAR NUT (TIE ROD END JAM NUT) INSTALLATION

Screw in the tie rod end to achieve the right and left length as illustrated. Lock with the jam nut.

NOTE: The locking nuts must be tightened securely only after the steering gear is installed and toe is adjusted.

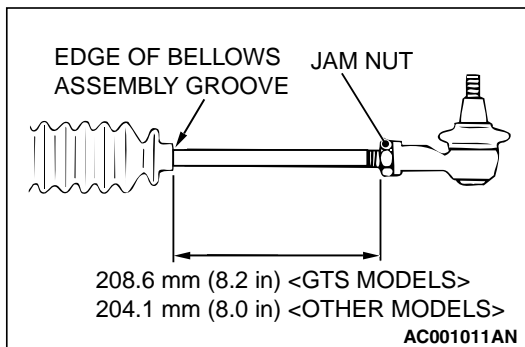

INSPECTION

M1372004400114

RACK

- Check the rack tooth surfaces for damage or wear.
- Check the oil seal contact surfaces for uneven wear.
- Check the rack for bends.

PINION AND VALVE ASSEMBLY

- Check the pinion gear tooth surfaces for damage or wear.
- Check for worn or defective seal ring.

BEARING

- Check for roughness or abnormal noise during bearing operation.
- Check the bearing for play.
- Check the needle roller bearings for roller slip-off.

OTHERS

- Check the cylinder inner surface of the rack housing for damage.
- Check the boots for damage, cracking or deterioration.
- Check the rack support for uneven wear or dents.
- Check the rack bushing for uneven wear or damage.

POWER STEERING OIL PUMP ASSEMBLY

REMOVAL AND INSTALLATION <2.4L ENGINE>

M1372005200339

Pre-removal Operation

- Side Under Cover (RH) Removal (Refer to GROUP 51, Under Cover P.51-11).
- Power Steering Fluid Draining (Refer to P.37-21).

Post-installation Operation

- Power Steering Fluid Supplying and Bleeding (Refer to P.37-21).
- Drive Belt Tension Adjusting (Refer to GROUP 00, Maintenance Service – Drive Belts P.00-45).
- Side Under Cover (RH) Installation (Refer to GROUP 51, Under Cover P.51-11).

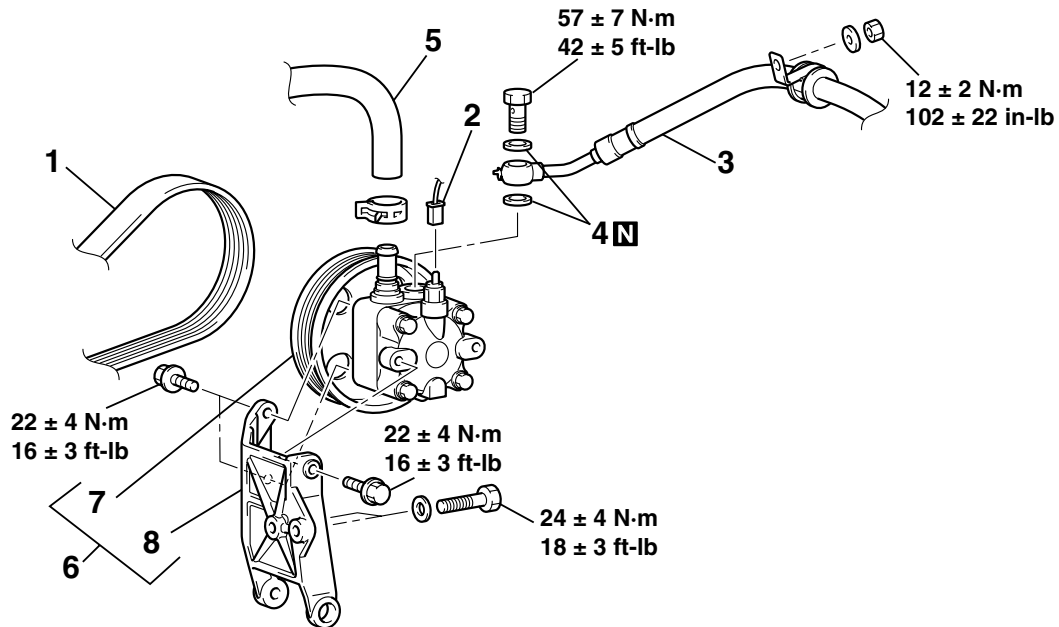

AC307219AB

REMOVAL STEPS

1. DRIVE BELT (REFER TO GROUP 11A, Engine Assembly P.11A-19)
2. PRESSURE SWITCH CONNECTOR
3. PRESSURE HOSE
4. GASKET
- >>A<< 5. SUCTION HOSE

REMOVAL STEPS (Continued)

6. POWER STEERING OIL PUMP AND BRACKET ASSEMBLY
7. POWER STEERING OIL PUMP BRACKET
8. POWER STEERING OIL PUMP ASSEMBLY

INSTALLATION SERVICE POINT

>>A<< SUCTION HOSE INSTALLATION

Install the suction hose so that the marking is positioned as shown in the illustration.

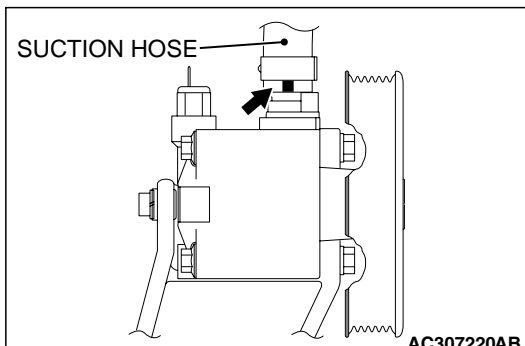

AC307220AB

REMOVAL AND INSTALLATION <3.8L ENGINE>

Pre-removal Operation

- Side Under Cover (RH) Removal (Refer to GROUP 51, Under Cover P.51-11).
- Strut Tower Bar (Refer to GROUP 42, Strut Tower Bar P.42-12).
- Power Steering Fluid Draining (Refer to P.37-21).

Post-installation Operation

- Power Steering Fluid Supplying and Bleeding (Refer to P.37-21).
- Drive Belt Tension Adjusting (Refer to GROUP 00, Maintenance Service – Drive Belts P.00-45).
- Strut Tower Bar (Refer to GROUP 42, Strut Tower Bar P.42-12).
- Side Under Cover (RH) Installation (Refer to GROUP 51, Under Cover P.51-11).

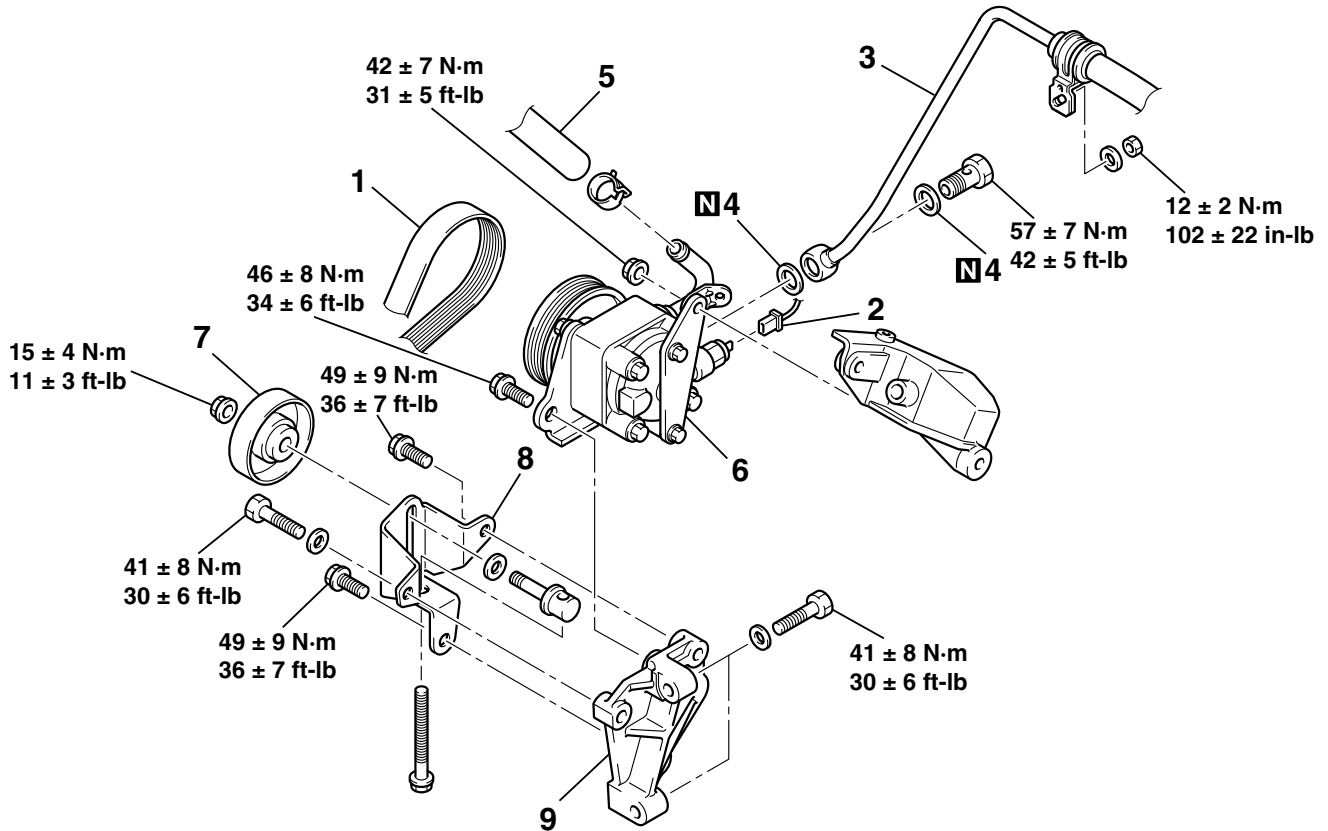

AC206484AC

REMOVAL STEPS

1. DRIVE BELT (REFER TO GROUP 11C, Engine Assembly P.11C-16).)
2. PRESSURE SWITCH CONNECTOR <<A>>
3. PRESSURE HOSE
4. GASKET
- >>A<< 5. SUCTION HOSE
- CONNECTION OF STABILIZER BAR AND STABILIZER LINK (REFER TO GROUP 33, Stabilizer Bar P.33-20)

REMOVAL STEPS (Continued)

- STEERING GEAR AND LINKAGE PROTECTOR (REFER TO P.37-33)
- 6. POWER STEERING OIL PUMP ASSEMBLY
- 7. BELT TENSIONER PULLEY
- 8. BELT TENSIONER BRACKET
- 9. POWER STEERING OIL PUMP BRACKET

REMOVAL SERVICE POINT

<<A>> POWER STEERING OIL PUMP ASSEMBLY REMOVAL

Turn up the stabilizer disconnected from the stabilizer link fully, and remove the power steering oil pump assembly after turning the steering wheel fully to left.

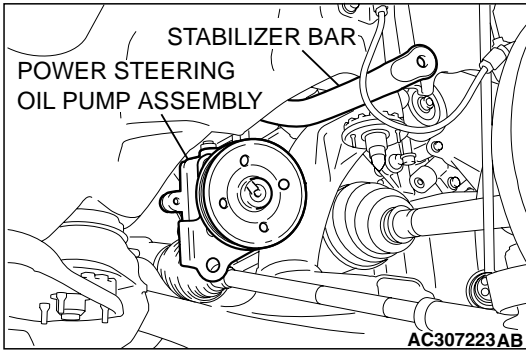

INSTALLATION SERVICE POINT

>>A<< SUCTION HOSE INSTALLATION

Install the suction hose so that the marking is positioned as shown in the illustration.

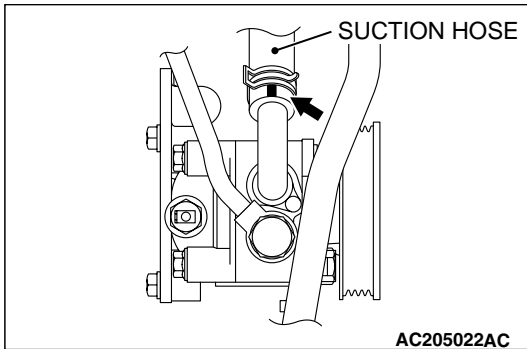

INSPECTION

- Check the drive belt for cracks.
- Check the pulley for uneven rotation.

M1372005300206

POWER STEERING HOSES

REMOVAL AND INSTALLATION

M1372005700431

Pre-removal Operation

- Side Under Cover (RH) Removal (Refer to GROUP 51, Under Cover P.51-11).
- Power Steering Fluid Draining (Refer to P.37-21).
- Front Bumper Removal (Refer to P.51-2). <2.4L ENGINE>
- Radiator Grille Removal (Refer to P.51-5). <2.4L ENGINE>

Post-installation Operation

- Radiator Grille Installation (Refer to P.51-5). <2.4L ENGINE>
- Front Bumper Installation (Refer to P.51-2). <2.4L ENGINE>
- Power Steering Fluid Supplying and Bleeding (Refer to P.37-21).
- Side Under Cover (RH) Installation (Refer to GROUP 51, Under Cover P.51-11).

<2.4 L ENGINE>

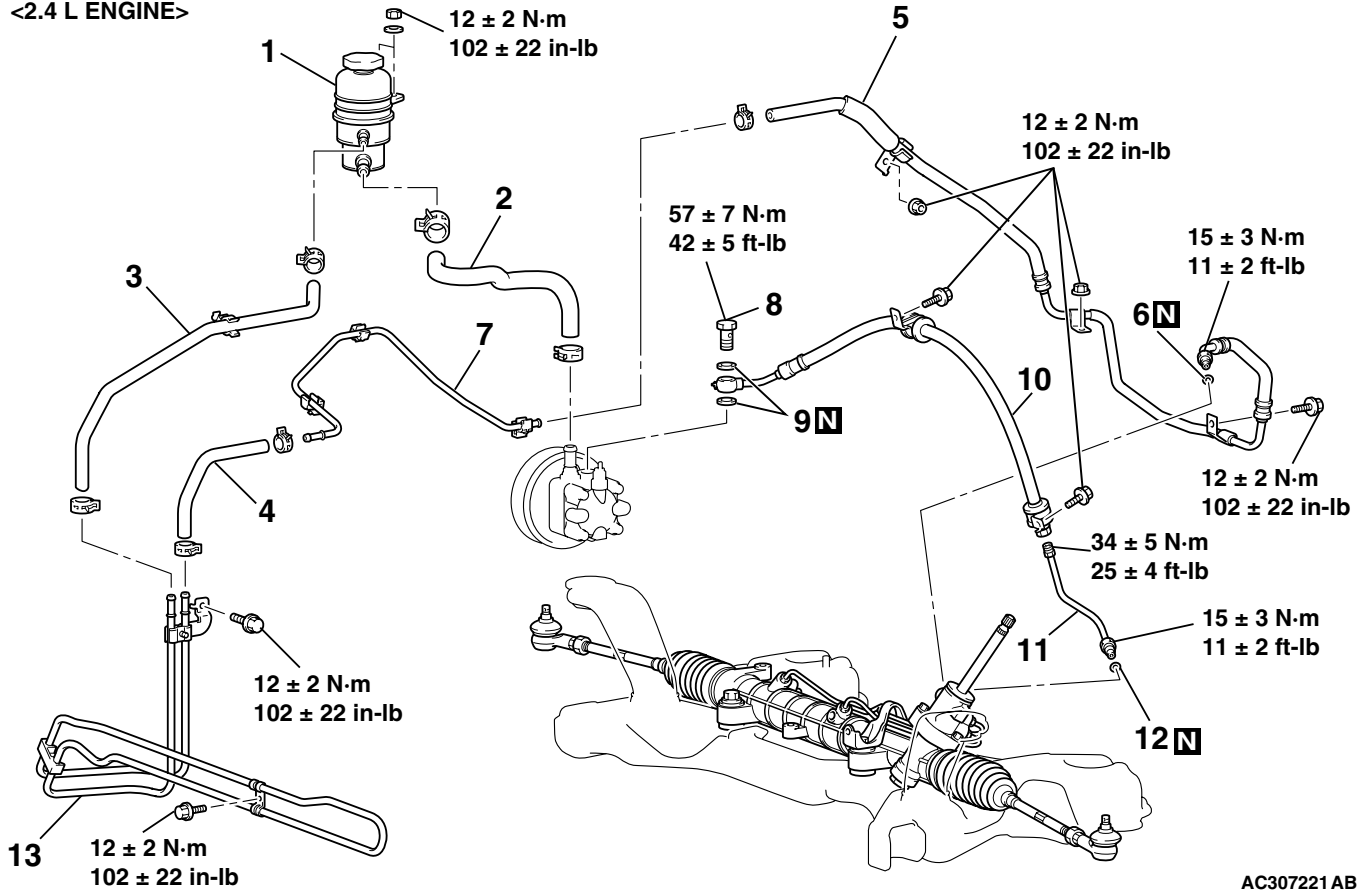

AC307221 AB

<3.8 L ENGINE>

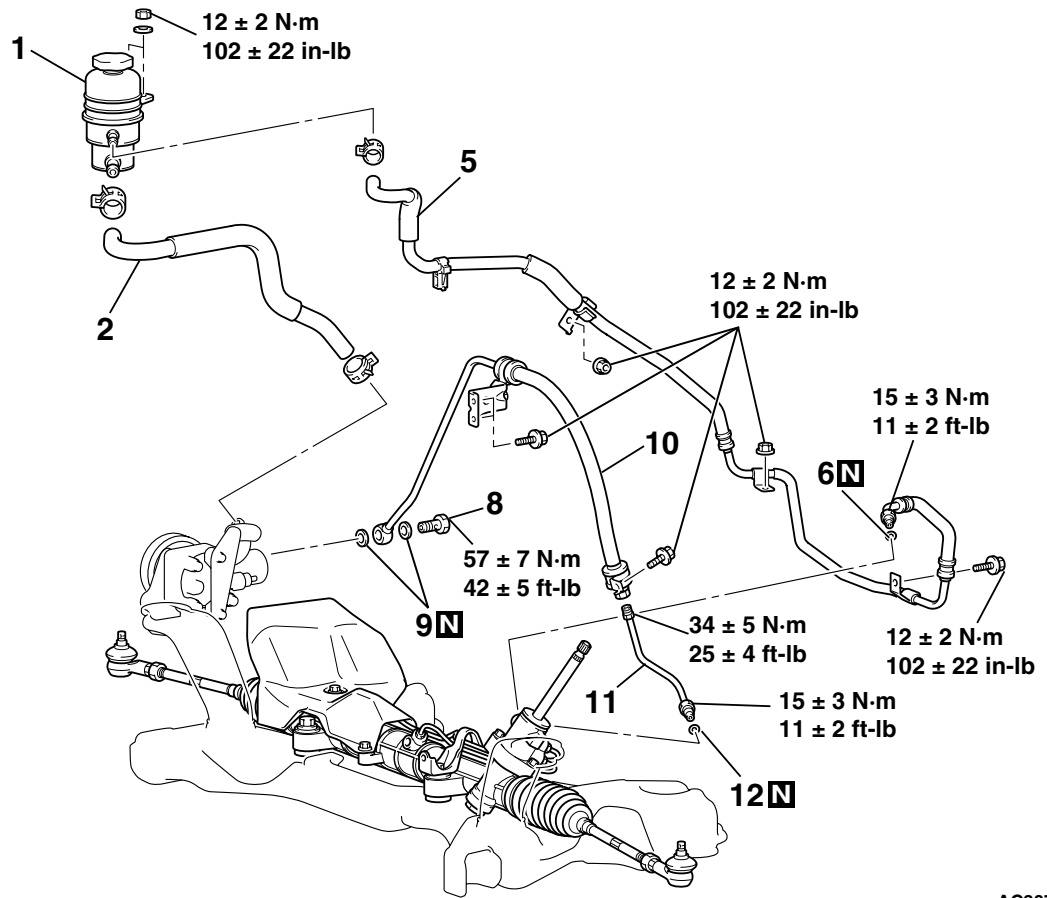

AC307222 AC

REMOVAL STEPS

- 1. OIL RESERVOIR
- >>F<< 2. SUCTION HOSE
- >>E<< 3. RETURN HOSE (M)
- >>D<< 4. RETURN HOSE (R)
- >>C<< 5. RETURN TUBE ASSEMBLY
- 6. O-RING
- >>B<< 7. RETURN TUBE (R)

REMOVAL STEPS (Continued)

- 8. EYE BOLT
- 9. GASKET
- >>A<< 10. PRESSURE HOSE
- >>A<< 11. PRESSURE TUBE ASSEMBLY
- 12. O-RING
- 13. COOLER TUBE ASSEMBLY

INSTALLATION SERVICE POINTS

>>A<< PRESSURE TUBE ASSEMBLY/PRESSURE HOSE INSTALLATION

Align the markings as shown in the illustration and tighten the nut.

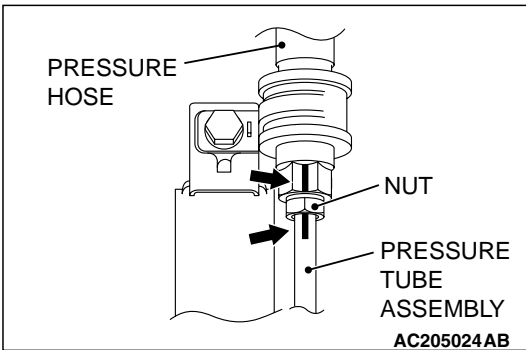
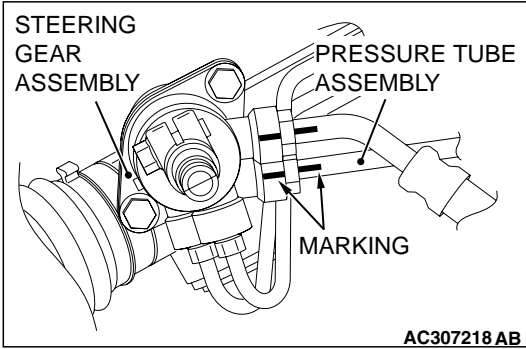

>>B<< RETURN TUBE (R) INSTALLATION

Install the return tube (R) so that the marking is positioned as shown in the illustration.

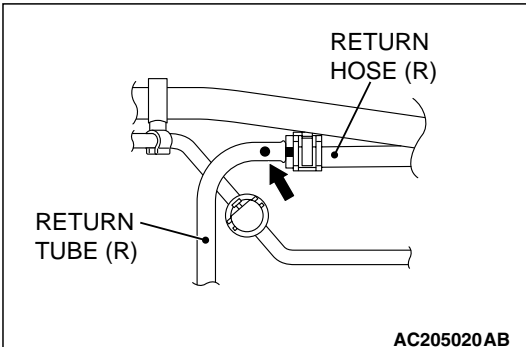

>>C<< RETURN TUBE ASSEMBLY INSTALLATION

1. Install the return tube assembly so that the marking is positioned as shown in the illustration.
2. Align the markings as shown in the illustration and tighten the nut.

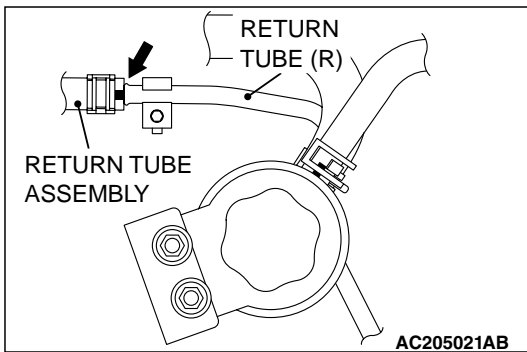
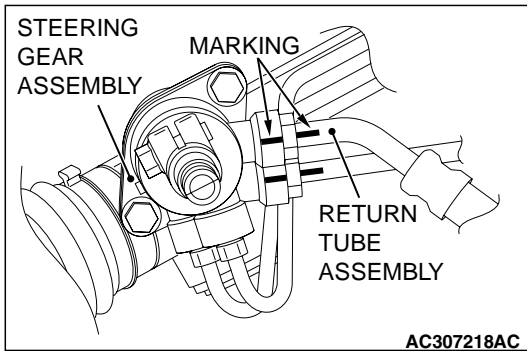

>>D<< RETURN HOSE (R) INSTALLATION

Install the return hose (R) so that the markings are positioned as shown in the illustration.

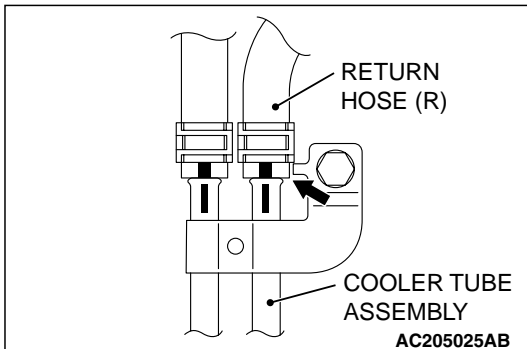
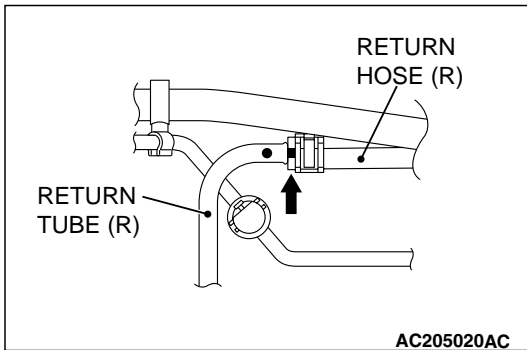

>>E<< RETURN HOSE (M) INSTALLATION

Install the return hose (M) so that the markings are positioned as shown in the illustration.

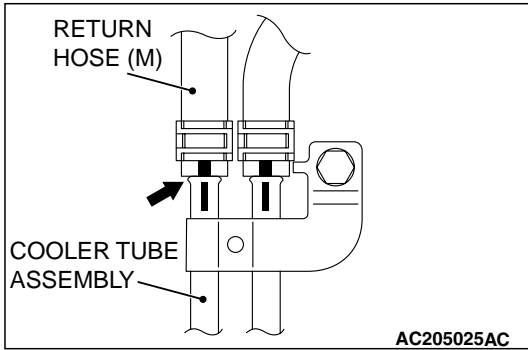
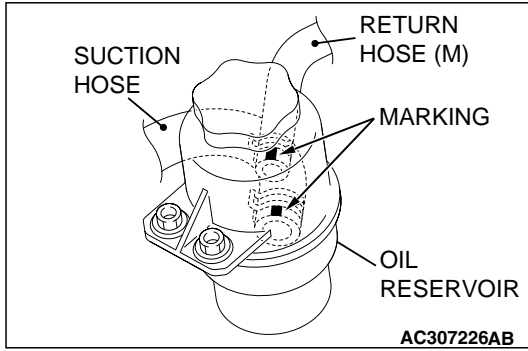

>>F<< SUCTION HOSE INSTALLATION

Install the suction hose so that the marking is positioned as shown in the illustration.

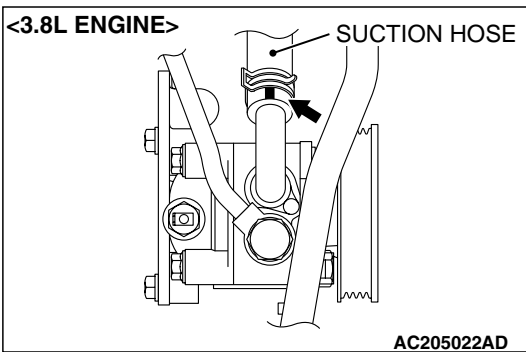
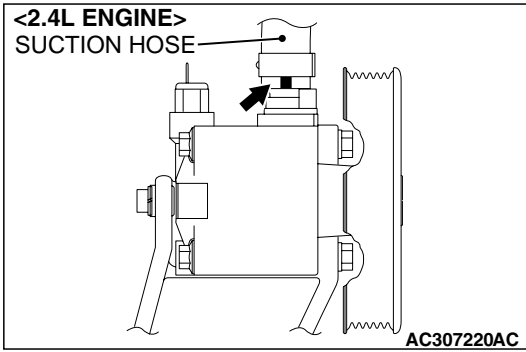
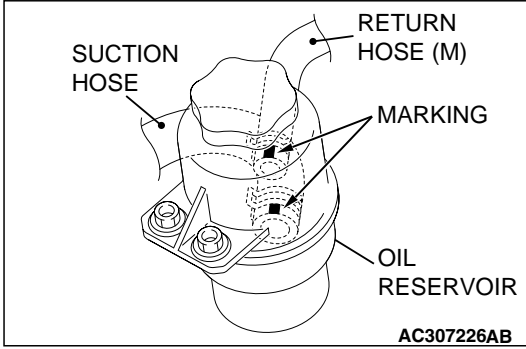

SPECIFICATIONS**FASTENER TIGHTENING SPECIFICATIONS**

M1372008400310

ITEM	SPECIFICATION
Power steering gear box and linkage (removal and installation)	
Crossmember mounting bolt	180 ± 20 N·m (133 ± 14 ft-lb)
Crossmember mounting nut	180 ± 20 N·m (133 ± 14 ft-lb)
Front axle crossmember stay mounting bolt and nut	83 ± 12 N·m (61 ± 9 ft-lb)
Lower arm and crossmember connecting nut	165 ± 15 N·m (122 ± 11 ft-lb)
Power steering gear bracket mounting bolt	58 ± 7 N·m (43 ± 5 ft-lb)
Pressure tube flare nut	15 ± 3 N·m (11 ± 2 ft-lb)
Pressure hose mounting bolt and nut	12 ± 2 N·m (102 ± 22 in-lb)
Rear roll stopper mounting bolt	58 ± 7 N·m (43 ± 5 ft-lb)
Rear roll stopper to power steering gear bracket connecting bolt	58 ± 7 N·m (43 ± 5 ft-lb)
Rear roll stopper to rear roll stopper bracket connecting nut	58 ± 7 N·m (43 ± 5 ft-lb)
Return tube flare nut	15 ± 3 N·m (11 ± 2 ft-lb)
Return tube mounting bolt and nut	12 ± 2 N·m (102 ± 22 in-lb)
Steering column assembly and steering gear connecting bolt	18 ± 2 N·m (13 ± 2 ft-lb)
Steering gear and linkage mounting bolt	83 ± 12 N·m (61 ± 9 ft-lb)
Steering gear and linkage protector mounting bolt	12 ± 2 N·m (102 ± 22 in-lb)
Tie rod	89 ± 9 N·m (65 ± 7 ft-lb)
Tie rod end jam nut	52 ± 2 N·m (38 ± 2 ft-lb)
Tie rod end to knuckle self-locking nut	29 ± 4 N·m (21 ± 3 ft-lb)
Power steering gear box and linkage (disassembly and assembly)	
P/S oil feed tube assembly flare nut	13 ± 3 N·m (116 ± 26 in-lb)
Steering gear inner nut (pinion and valve assembly jam nut)	25 ± 4 N·m (18 ± 3 ft-lb)
Steering gear inner nut (rack support cover jam nut)	59 ± 10 N·m (44 ± 7 ft-lb)
Steering gear nut (tie rod end jam nut)	52 ± 2 N·m (38 ± 2 ft-lb)
Steering gear plug (end plug)	59 ± 10 N·m (44 ± 7 ft-lb)
Steering gear rack support cover	12 ± 2 N·m (107 ± 17 in-lb)
Steering tie rod	84 ± 14 N·m (62 ± 10 ft-lb)
Valve housing bolt	22 ± 4 N·m (16 ± 3 ft-lb)
Power steering hose	
Cooler tube clamp bolt <2.4L ENGINE>	12 ± 2 N·m (102 ± 22 in-lb)
Oil pump eye bolt	57 ± 7 N·m (42 ± 5 ft-lb)
Oil reservoir nut	12 ± 2 N·m (102 ± 22 in-lb)
Pressure hose, pressure tube, return tube clamp bolt	12 ± 2 N·m (102 ± 22 in-lb)
Pressure hose clamp nut <3.8L ENGINE>	12 ± 2 N·m (102 ± 22 in-lb)
Pressure tube, return tube flare nut	15 ± 3 N·m (11 ± 2 ft-lb)
Return tube clamp nut	12 ± 2 N·m (102 ± 22 in-lb)

ITEM	SPECIFICATION
Power steering oil pump	
Belt tensioner bracket to power steering pump bracket connecting bolt (long) <3.8L ENGINE>	41 ± 8 N·m (30 ± 6 ft-lb)
Belt tensioner bracket to power steering pump bracket connecting bolt (short) <3.8L ENGINE>	49 ± 9 N·m (36 ± 7 ft-lb)
Belt tensioner pulley mounting nut <3.8L ENGINE>	15 ± 4 N·m (11 ± 3 ft-lb)
Oil pump eye bolt	57 ± 7 N·m (42 ± 5 ft-lb)
Power steering oil pump mounting bolt <2.4L ENGINE>	22 ± 4 N·m (16 ± 3 ft-lb)
Power steering oil pump mounting bolt <3.8L ENGINE>	46 ± 8 N·m (34 ± 6 ft-lb)
Power steering oil pump mounting nut <3.8L ENGINE>	42 ± 7 N·m (31 ± 5 ft-lb)
Power steering oil pump bracket mounting bolt <2.4L ENGINE>	24 ± 4 N·m (18 ± 3 ft-lb)
Power steering oil pump bracket mounting bolt <3.8L ENGINE>	41 ± 8 N·m (30 ± 6 ft-lb)
Pressure hose clamp bolt <2.4L ENGINE>	12 ± 2 N·m (102 ± 22 in-lb)
Pressure hose clamp nut <3.8L ENGINE>	12 ± 2 N·m (102 ± 22 in-lb)
Steering shaft	
Steering column assembly and steering gear connecting bolt	18 ± 2 N·m (13 ± 2 ft-lb)
Steering column assembly mounting bolt	12 ± 2 N·m (102 ± 22 in-lb)
Steering wheel	
Steering wheel dynamic damper	3.9 ± 0.9 N·m (35 ± 8 in-lb)
Steering wheel mounting nut	41 ± 8 N·m (30 ± 6 ft-lb)
Torx screw	9.0 ± 2.0 N·m (80 ± 17 in-lb)

GENERAL SPECIFICATIONS

M1372000200282

ITEMS		SPECIFICATIONS		
		2.4L ENGINE	3.8L ENGINE	
			16-INCH WHEELS	17-INCH WHEELS
Steering wheel	Type	4-spoke type	4-spoke type	4-spoke type
	Outside diameter mm (in)	380 (14.9)	380 (14.9)	380 (14.9)
	Maximum number of turns	2.94	2.94	2.76
Steering column	Column mechanism	Shock absorbing mechanism and Tilt steering mechanism		
Power steering type		Integral type	Integral type	Integral type
Oil pump	Type	vane pump	vane pump	vane pump
	Basic discharge amount cm ³ /rev. (cu in/rev)	9.6 (0.59)	9.6 (0.59)	9.6 (0.59)
	Relief pressure MPa (psi)	8.8 (1,422)	9.8 (1,422)	9.8 (1,422)
	Reservoir type	Separate type (plastic)		
	Pressure switch	Equipped	Equipped	Equipped

ITEMS		SPECIFICATIONS		
		2.4L ENGINE	3.8L ENGINE	
			16-INCH WHEELS	17-INCH WHEELS
Steering gear	Type	Rack and pinion	Rack and pinion	Rack and pinion
	Stroke ratio (Rack stroke/Steering wheel Maximum turning radius)	49.62	49.62	49.62
	Rack stroke mm (in)	146 (5.5)	146 (5.5)	137 (5.1)

SERVICE SPECIFICATIONS

M1372000300405

ITEM		STANDARD VALUE	LIMIT
Steering wheel free play mm (in)	With engine running	–	30 (1.2)
	With engine stopped	10 (0.4) or less	–
Steering angle	Inside wheel	37°12' ± 2°00' <vehicles with 16-inch wheels> 33°48' ± 2°00' <vehicles with 17-inch wheels>	–
	Outside wheel (reference)	30°18' <vehicles with 16-inch wheels> 28°18' <vehicles with 17-inch wheels>	–
Toe-in mm (in)		0 ± 3 (0 ± 0.12)	–
Tie rod end ball joint breakaway torque N·m (in-lb)		0.5 – 3.5 (4.4 – 31.0)	–
Tie rod swing resistance N (lb) [Tie rod swing torque N·m (in-lb)]		3.7 – 18.1 (0.83 – 40.7) <vehicles with 16-inch wheels> 3.6 – 17.8 (0.81 – 4.00) <vehicles with 17-inch wheels> [1.0 – 4.9 (8.8 – 43.4)]	–
Stationary steering effort N (lb) [Fluctuation allowance N (lb)]		30 (6.7) or less [5.9 (1.33) or less]	–
Oil pump pressure MPa (psi)	Oil pump relief pressure	8.3 – 8.8 (1,204 – 1,276) <2.4L engine> 9.3 – 9.8 (1,349 – 1,421) <3.8L engine>	–
	Pressure under no-load conditions	0.8 – 1.0 (116 – 145) <2.4L engine> 0.8 – 1.0 (116 – 145) <3.8L engine>	–
	Steering gear retention hydraulic pressure	8.3 – 8.8 (1,204 – 1,276) <2.4L engine> 9.3 – 9.8 (1,349 – 1,421) <3.8L engine>	–
Oil pressure switch operating pressure MPa (psi)	OFF → ON	1.8 – 2.4 (261 – 348)	–
	ON → OFF	0.8 – 2.4 (116 – 348)	–
Steering gear total pinion torque N·m (in-lb) [Change in torque N·m (in-lb)]		0.8 – 1.9 (7.1 – 16.8) [0.7 (6.2) or less]	–
Opening dimension of special tool MB991561 mm (in)		1.9 (0.07)	–
Band crimped width mm (in)		1.4 – 1.8 (0.06 – 0.07)	–

LUBRICANTS

M1372000400372

ITEM		SPECIFIED LUBRICANT	QUANTITY dm ³ (qt)
Power steering fluid		GENUINE MITSUBISHI POWER STEERING FLUID	1.2 (1.3)
Gear box	Bearing	GENUINE MITSUBISHI POWER STEERING FLUID	As required
	O-ring		
	Oil seal		
	Special tool (MB991213)		
	Pinion and valve assembly seal ring part		
	Bellows	Silicon grease	As required
Oil pump	Power steering fluid	GENUINE MITSUBISHI POWER STEERING FLUID	0.8 (0.85)

SEALANT

M1372000500379

ITEM		SPECIFIED SEALANT
Power steering gear box	End plug	3M™ AAD Part No.8661, 8663, 8672, 8678, 8679 or equivalent
	Rack support cover	

NOTES