

A
B
C

WW

SECTION

WIPER, WASHER & HORN

CONTENTS

<p>PRECAUTION 2</p> <p>Precautions for Supplemental Restraint System (SRS) “AIR BAG” and “SEAT BELT PRE-TENSIONER” 2</p> <p>FRONT WIPER AND WASHER SYSTEM 3</p> <p>Components Parts and Harness Connector Location 3</p> <p>System Description 3</p> <p> LOW SPEED WIPER OPERATION 4</p> <p> HI SPEED WIPER OPERATION 4</p> <p> INTERMITTENT OPERATION 4</p> <p> AUTO STOP OPERATION 5</p> <p> FRONT WASHER OPERATION 5</p> <p> MIST OPERATION 5</p> <p> FAIL-SAFE FUNCTION 5</p> <p> COMBINATION SWITCH READING FUNCTION... 5</p> <p>CAN Communication System Description 5</p> <p>Schematic 6</p> <p>Wiring Diagram — WIPER — 7</p> <p>Terminals and Reference Values for BCM 10</p> <p>Terminals and Reference Values for IPDM E/R 11</p> <p>Work Flow 11</p> <p>Preliminary Inspection 11</p> <p> INSPECTION FOR POWER SUPPLY AND GROUND CIRCUIT 11</p> <p>CONSULT-II Function (BCM) 13</p> <p> CONSULT-II OPERATION 13</p> <p> WORK SUPPORT 14</p> <p> DATA MONITOR 14</p> <p> ACTIVE TEST 15</p> <p>CONSULT-II Function (IPDM E/R) 15</p> <p> CONSULT-II OPERATION 15</p> <p> DATA MONITOR 16</p> <p> ACTIVE TEST 16</p> <p>Front Wiper Does Not Operate 18</p> <p> FRONT WIPER STOP POSITION IS INCORRECT 21</p> <p> ONLY FRONT WIPER LOW DOES NOT OPERATE 22</p> <p> ONLY FRONT WIPER HI DOES NOT OPERATE. 24</p>	<p> ONLY FRONT WIPER INTERMITTENT DOES NOT OPERATE 25</p> <p> FRONT WIPER INTERMITTENT OPERATION SWITCH POSITION CANNOT BE ADJUSTED... 26</p> <p> WIPERS DO NOT WIPER WHEN FRONT WASHER OPERATES 26</p> <p> FRONT WIPERS OPERATE FOR 10 SECONDS, STOP FOR 20 SECONDS, AND AFTER REPEATING THIS OPERATION FIVE TIMES, THEY BECOME INOPERATIVE 26</p> <p>Front Wiper Arms 28</p> <p> REMOVAL AND INSTALLATION 28</p> <p> FRONT WIPER ARM ADJUSTMENT 28</p> <p>Wiper Motor and Linkage 29</p> <p> REMOVAL AND INSTALLATION 29</p> <p> REMOVAL 29</p> <p> INSTALLATION 29</p> <p>Washer Nozzle Adjustment 29</p> <p>Washer Tube Layout 30</p> <p>Wiper and Washer Switch 30</p> <p> REMOVAL AND INSTALLATION 30</p> <p> INSTALLATION 30</p> <p>Washer Fluid Reservoir 30</p> <p> REMOVAL AND INSTALLATION 30</p> <p>Washer Motor 31</p> <p> REMOVAL AND INSTALLATION 31</p> <p> INSTALLATION 31</p> <p>CIGARETTE LIGHTER 32</p> <p> Wiring Diagram — CIGAR — 32</p> <p> Removal and Installation 33</p> <p>POWER SOCKET 34</p> <p> Wiring Diagram — P/SCKT — 34</p> <p> Removal and Installation 35</p> <p>HORN 36</p> <p> Wiring Diagram — HORN — 36</p> <p> Removal and Installation 37</p> <p> REMOVAL (HORN HIGH) 37</p> <p> INSTALLATION (HORN HIGH) 37</p> <p> REMOVAL (HORN LOW) 37</p> <p> INSTALLATION (HORN LOW) 37</p>
--	---

A
B
C
D
E
F
G
H
I
J
L
M

WW

PRECAUTION

PRECAUTION

PF0:00011

Precautions for Supplemental Restraint System (SRS) “AIR BAG” and “SEAT BELT PRE-TENSIONER”

EKS00AE9

The Supplemental Restraint System such as “AIR BAG” and “SEAT BELT PRE-TENSIONER”, used along with a front seat belt, helps to reduce the risk or severity of injury to the driver and front passenger for certain types of collision. This system includes seat belt switch inputs and dual stage front air bag modules. The SRS system uses the seat belt switches to determine the front air bag deployment, and may only deploy one front air bag, depending on the severity of a collision and whether the front occupants are belted or unbelted. Information necessary to service the system safely is included in the SRS and SB section of this Service Manual.

WARNING:

- To avoid rendering the SRS inoperative, which could increase the risk of personal injury or death in the event of a collision which would result in air bag inflation, all maintenance must be performed by an authorized NISSAN/INFINITI dealer.
- Improper maintenance, including incorrect removal and installation of the SRS, can lead to personal injury caused by unintentional activation of the system. For removal of Spiral Cable and Air Bag Module, see the SRS section.
- Do not use electrical test equipment on any circuit related to the SRS unless instructed to in this Service Manual. SRS wiring harnesses can be identified by yellow and/or orange harnesses or harness connectors.

FRONT WIPER AND WASHER SYSTEM

FRONT WIPER AND WASHER SYSTEM

PF2:28810

Components Parts and Harness Connector Location

EKS00GFR

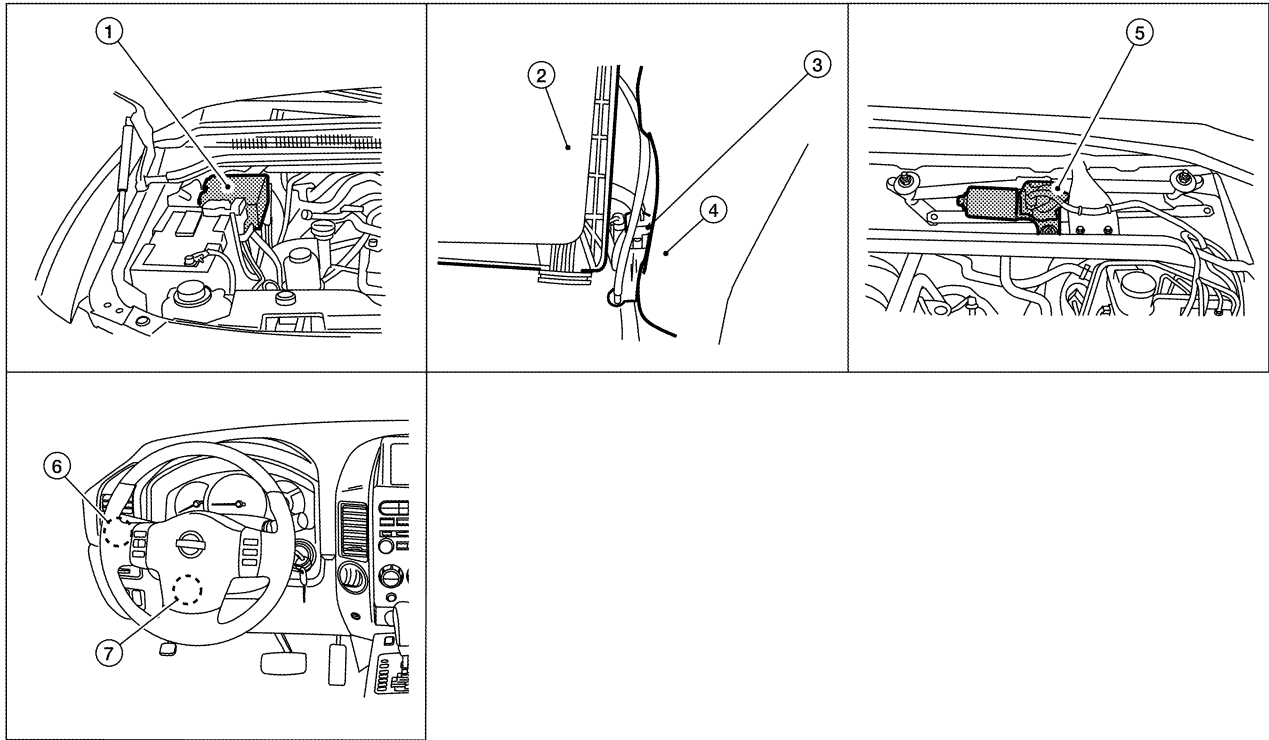

1. IPDM E/R
E118, E119, E120, E121, E122, E123,
E124
4. Washer fluid reservoir
7. BCM M18, M20

2. Air cleaner case
5. Front wiper motor
E23

3. Front washer motor connector
E105

6. Combination switch (wiper switch)
M28

WKIA5719E

System Description

EKS00AEC

- Both front wiper relays are located in the IPDM E/R (intelligent power distribution module engine room).
- The wiper switch (combination switch) is composed of a combination of 5 output terminals and 5 input terminals. Terminal combination status is read by the BCM (body control module) when the wiper switch is turned ON.
- BCM controls front wiper LO, HI, and INT (intermittent) operation.
- IPDM E/R operates the wiper motor according to CAN communication signals from the BCM.

Power is supplied at all times

- through 50A fusible link (letter f , located in the fuse and fusible link box)
- to BCM terminal 70, and
- through 30A fuse (No. 39, located in the IPDM E/R)
- to front wiper relay (located in the IPDM E/R).

With the ignition switch in ON or START position, power is supplied

- through 10A fuse (No. 59, located in the fuse and relay box)
- to BCM terminal 38.

Ground is supplied

- to BCM terminal 67 and
- to combination switch terminal 12

A
B
C
D
E
F
G
H
I

J

WW

L

M

FRONT WIPER AND WASHER SYSTEM

- through grounds M57, M61 and M79, and
- to IPDM E/R terminals 38 and 59 and
- to front wiper motor terminal 1
- through grounds E9, E15 and E24.

LOW SPEED WIPER OPERATION

When the ignition switch is in the ON or START position, and the front wiper switch is turned to the low position, the BCM detects a low speed wiper ON request through the combination switch (wiper switch) reading function.

The BCM then sends a front wiper (low) request signal over CAN communication lines

- from BCM terminals 39 and 40
- to IPDM E/R terminals 39 and 40.

When IPDM E/R receives front wiper (low) request signal, it supplies ground to energize the front wiper relay. With the front wiper relay energized, power is supplied

- through front wiper relay
- through front wiper high relay
- through IPDM E/R terminal 32
- to front wiper motor terminal 3.

With power and ground supplied, the front wiper motor operates at low speed.

HI SPEED WIPER OPERATION

When the ignition switch is in the ON or START position, and the front wiper switch is turned to the high position, the BCM detects a high speed wiper ON request through the combination switch (wiper switch) reading function.

The BCM then sends a front wiper (high) request signal over CAN communication lines

- from BCM terminals 39 and 40
- to IPDM E/R terminals 39 and 40.

When the IPDM E/R receives a front wiper (high) request signal, it supplies ground to energize the front wiper and the front wiper high relays.

With the front wiper and the front wiper high relays energized, power is supplied

- through front wiper relay
- through front wiper high relay
- through IPDM E/R terminal 35
- to front wiper motor terminal 2.

With power and ground supplied, the front wiper motor operates at high speed.

INTERMITTENT OPERATION

Wiper intermittent operation delay interval is determined from the combination of the intermittent wiper dial position inputs and vehicle speed. During each intermittent operation delay interval, the BCM sends a front wiper request signal to the IPDM E/R to operate the wipers.

When the ignition switch is in the ON or START position, and the front wiper switch is turned to an intermittent position, the BCM detects a front wiper (intermittent) ON request through the combination switch (wiper switch) reading function.

The BCM then sends a front wiper (intermittent) request signal over CAN communication lines

- from BCM terminals 39 and 40
- to IPDM E/R terminals 39 and 40.

When the BCM determines that combination switch status is front wiper intermittent ON, it performs the following operations.

- BCM detects ON/OFF status of intermittent wiper dial position
- BCM calculates operation interval from wiper dial position and vehicle speed signal received through CAN communications.
- BCM sends front wiper request signal (INT) to IPDM E/R at calculated operation interval.

When the IPDM E/R receives a front wiper request signal (INT), it supplies ground to energize the front wiper relay. It then sends an auto-stop signal to the BCM, and conducts intermittent front wiper motor operation.

FRONT WIPER AND WASHER SYSTEM

AUTO STOP OPERATION

When the wiper arms are not located at the base of the windshield, and the wiper switch is turned OFF, the wiper motor will continue to operate until the wiper arms reach the windshield base. When the wiper arms reach the base of windshield, front wiper motor terminals 6 and 1 are connected.

Ground is supplied

- to IPDM E/R terminal 43
- through front wiper motor terminal 6
- through front wiper motor terminal 1
- through grounds E9, E15 and E24.

The IPDM E/R sends an auto stop operation signal to the BCM through CAN communication lines.

When the BCM receives an auto stop operation signal, the BCM sends wiper stop signal to the IPDM E/R over CAN communication lines. The IPDM E/R then de-energizes the front wiper relay.

The wiper motor will then stop the wiper arms at the STOP position.

FRONT WASHER OPERATION

When the ignition switch is in the ON or START position, and the front washer switch is OFF, the front washer motor is supplied power

- through 10A fuse (No. 9, located in the fuse block J/B)
- to front washer motor terminal 1.

When the front wiper switch is in the front washer position, the BCM detects a front washer signal request through the combination switch (wiper switch) reading function.

Combination switch ground is supplied

- to front washer motor terminal 2
- through combination switch (wiper switch) terminal 11
- through combination switch (wiper switch) terminal 12
- through grounds M57, M61 and M79.

With ground supplied, the front washer motor operates.

When the BCM detects that front washer motor has operated for 0.4 seconds or longer, the BCM uses CAN communication and sends a wiper request signal to the IPDM E/R for low speed operation of wipers.

When the BCM detects that the washer switch is OFF, low speed operation cycles approximately 3 times and then stops.

MIST OPERATION

When the wiper switch is temporarily placed in the mist position, wiper low speed operation cycles once and then stops.

For additional information about wiper operation under this condition, refer to [WW-4, "LOW SPEED WIPER OPERATION"](#).

If the switch is held in the mist position, low speed operation continues.

FAIL-SAFE FUNCTION

The BCM includes fail-safe function to prevent malfunction of electrical components controlled by CAN communications if a malfunction in CAN communications occurs.

The BCM uses CAN communications to stop output of electrical components it controls.

Until the ignition switch is turned off, the front wiper system remains in same status as just before fail-safe control was initiated. (If wiper was in low speed operation just before fail-safe, it continues low speed operation until ignition switch is turned OFF.)

When fail-safe status is initiated, the BCM remains in standby until normal signals are received.

When normal signals are received, fail-safe status is canceled.

COMBINATION SWITCH READING FUNCTION

Refer to [BCS-3, "COMBINATION SWITCH READING FUNCTION"](#).

CAN Communication System Description

Refer to [LAN-25, "CAN COMMUNICATION"](#).

EKS00AED

FRONT WIPER AND WASHER SYSTEM

Schematic

EKS00AEE

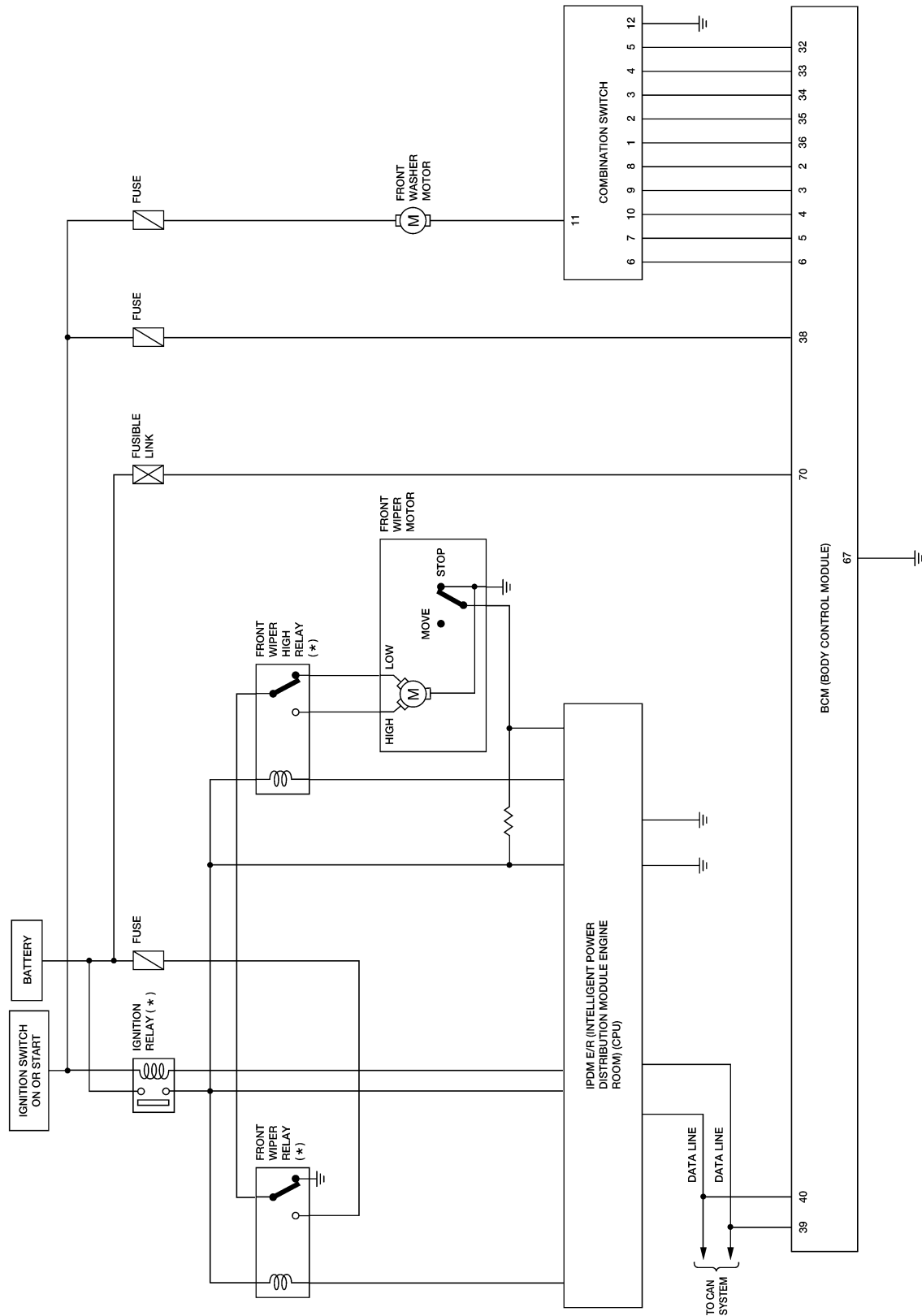

*: THIS RELAY IS BUILT INTO THE IPDM E/R (INTELLIGENT POWER DISTRIBUTION MODULE ENGINE ROOM)

FRONT WIPER AND WASHER SYSTEM

Wiring Diagram — WIPER —

EKS00AEF

WW-WIPER-01

— : DATA LINE

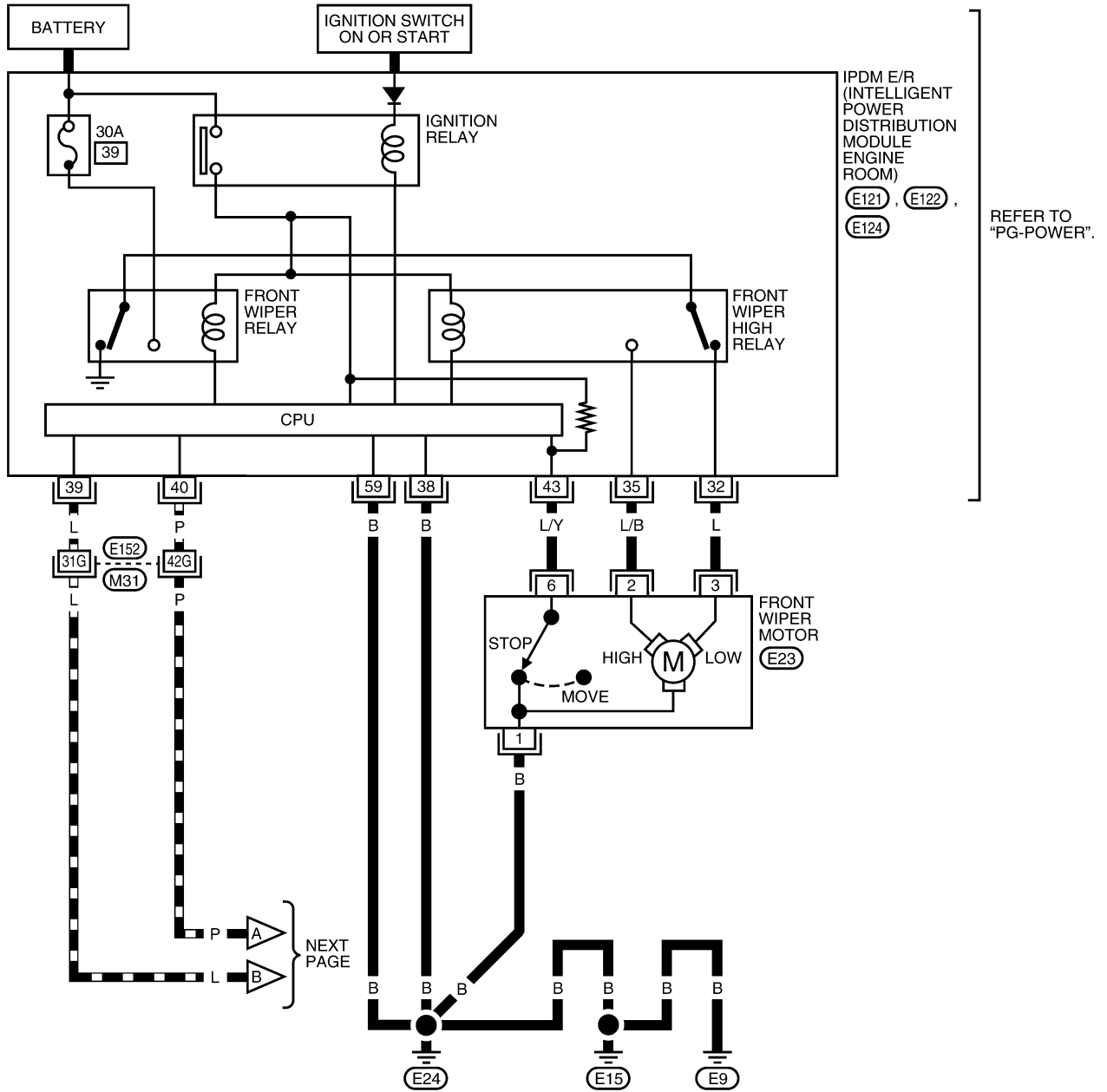

A
B
C
D
E
F
G
H
I
J
L
M

WW

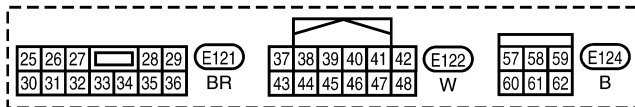
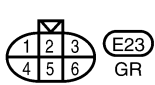

FRONT WIPER AND WASHER SYSTEM

WW-WIPER-02

▬ : DATA LINE

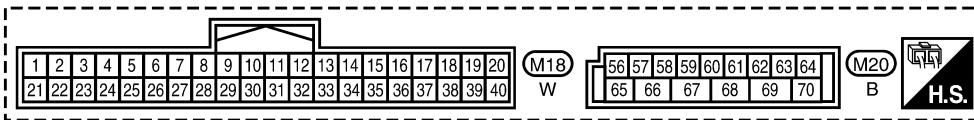
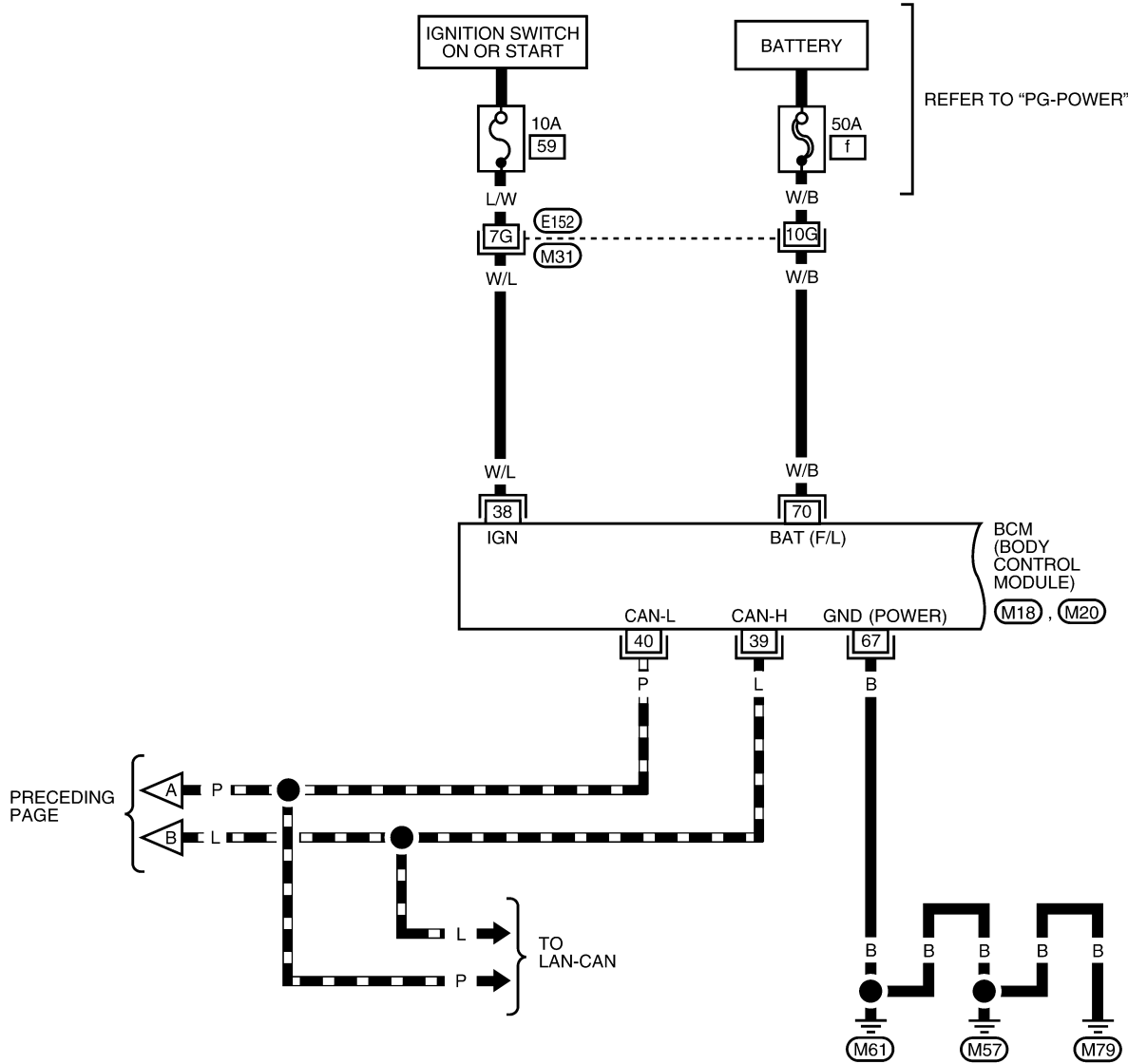

REFER TO THE FOLLOWING.
 M31 - SUPER MULTIPLE JUNCTION (SMJ)

WKWA3699E

FRONT WIPER AND WASHER SYSTEM

WW-WIPER-03

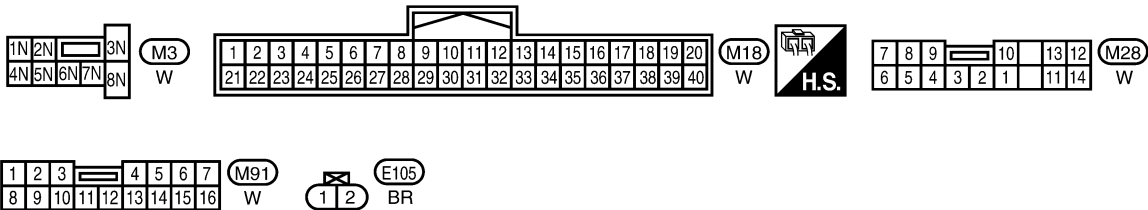
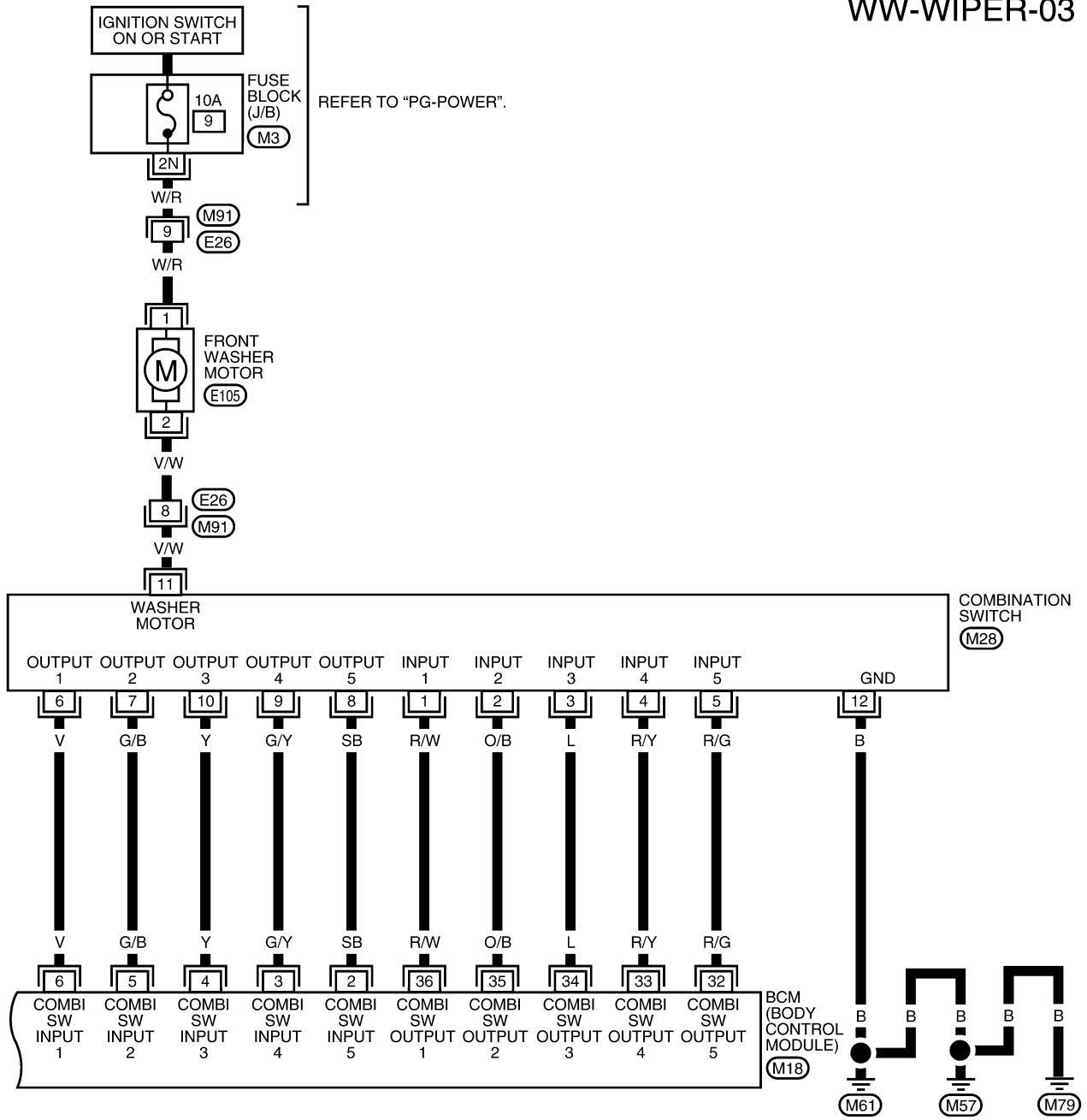



WKWA3700E

FRONT WIPER AND WASHER SYSTEM

Terminals and Reference Values for BCM

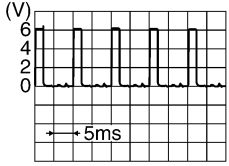
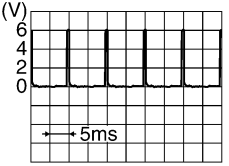
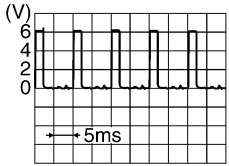
EKS00AEG

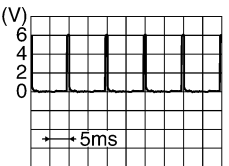
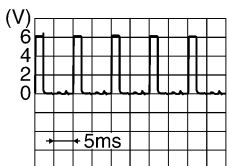
Terminal No.	Wire color	Signal name	Measuring condition		Reference Value (V) (Approx.)
			Ignition switch	Operation or condition	
2	SB	Combination switch input 5	ON	<ul style="list-style-type: none"> Light switch and wiper switch OFF Wiper dial position 4 	 <p style="text-align: right;">SKIA5291E</p>
3	G/Y	Combination switch input 4	ON	<ul style="list-style-type: none"> Light switch and wiper switch OFF Wiper dial position 4 	 <p style="text-align: right;">SKIA5292E</p>
4	Y	Combination switch input 3	ON	<ul style="list-style-type: none"> Light switch and wiper switch OFF Wiper dial position 4 	 <p style="text-align: right;">SKIA5291E</p>
5	G/B	Combination switch input 2	ON	<ul style="list-style-type: none"> Light switch and wiper switch OFF Wiper dial position 4 	 <p style="text-align: right;">SKIA5292E</p>
6	V	Combination switch input 1			
32	R/G	Combination switch output 5	ON	<ul style="list-style-type: none"> Light switch and wiper switch OFF Wiper dial position 4 	 <p style="text-align: right;">SKIA5291E</p>
33	R/Y	Combination switch output 4	ON	<ul style="list-style-type: none"> Light switch and wiper switch OFF Wiper dial position 4 	 <p style="text-align: right;">SKIA5292E</p>
34	L	Combination switch output 3	ON	<ul style="list-style-type: none"> Light switch and wiper switch OFF Wiper dial position 4 	 <p style="text-align: right;">SKIA5291E</p>

FRONT WIPER AND WASHER SYSTEM

Terminal No.	Wire color	Signal name	Measuring condition		Reference Value (V) (Approx.)
			Ignition switch	Operation or condition	
35	O/B	Combination switch output 2	ON	<ul style="list-style-type: none"> Light switch and wiper switch OFF Wiper dial position 4 	
36	R/W	Combination switch output 1			
38	W/L	Ignition switch (ON)	ON	—	Battery
39	L	CAN-H	ON	—	—
40	P	CAN-L	ON	—	—
67	B	Ground	—	—	0
70	W/B	Battery power	OFF	—	Battery

Terminals and Reference Values for IPDM E/R

EKS00AEH

Terminal No.	Wire color	Signal name	Measuring condition		Reference value (V) (Approx.)	
			Ignition switch	Operation or condition		
32	L	Low speed signal	ON	Wiper switch	OFF	0
					LO	Battery
35	L/B	High speed signal	ON	Wiper switch	OFF	0
					HI	Battery
43	L/Y	Wiper auto stop signal	ON	Wiper operating		Battery
				Wiper stopped		0
38	B	Ground	—	—	0	
39	L	CAN-H	ON	—	—	
40	P	CAN-L	ON	—	—	
59	B	Ground	—	—	0	

Work Flow

EKS00AEI

1. Confirm the symptom or customer complaint.
2. Understand the system description, refer to [WW-3, "System Description"](#) .
3. Perform preliminary inspection, refer to [WW-11, "Preliminary Inspection"](#) .
4. Check symptom and repair or replace the cause of malfunction.
5. Does wiper function operate normally? If it operates normally, GO TO 6. If not, GO TO 4.
6. Inspection End.

Preliminary Inspection

EKS00AEJ

INSPECTION FOR POWER SUPPLY AND GROUND CIRCUIT

Inspection procedure

1. CHECK FUSE

Check if wiper or washer fuse is blown.

Unit	Power source	Fuse No.
Front washer motor	Ignition ON or START	9
Front wiper relay	Battery	39
BCM	Ignition ON or START	59
	Battery	f

FRONT WIPER AND WASHER SYSTEM

OK or NG

OK >> GO TO 2.

NG >> If fuse is blown, be sure to eliminate cause of blown fuse before installing new fuse. Refer to [PG-4, "POWER SUPPLY ROUTING CIRCUIT"](#) .

2. CHECK POWER SUPPLY CIRCUIT

1. Disconnect BCM connectors.
2. Check voltage between BCM harness connector terminals and ground.

Terminals		Ignition switch position	
(+)		(-)	
Connector	Terminal	OFF	ON
M18	38	0V	Battery voltage
M20	70	Battery voltage	

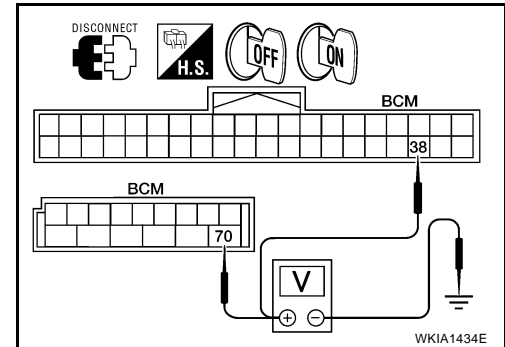

OK or NG

OK >> GO TO 3.

NG >> Check harness for open or short between BCM and fuse.

3. GROUND CIRCUIT INSPECTION (BCM)

Check for continuity between BCM terminal and ground.

Terminals		Ignition switch condition	Continuity
Connector	Terminal		
M20	67	OFF	Yes

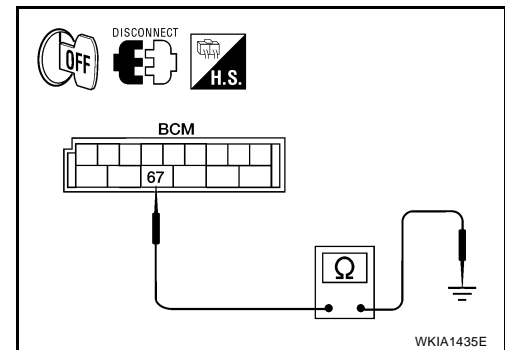

OK or NG

OK >> Inspection End.

NG >> Repair/replace BCM ground circuit.

FRONT WIPER AND WASHER SYSTEM

CONSULT-II Function (BCM)

EKS00AEK

CONSULT-II can display each diagnostic item using the diagnostic test modes shown following.

BCM diagnostic test item	Diagnostic mode	Description
Inspection by part	WORK SUPPORT	Supports inspections and adjustments. Commands are transmitted to the BCM for setting the status suitable for required operation, input/output signals are received from the BCM and received data is displayed.
	DATA MONITOR	Displays BCM input/output data in real time.
	ACTIVE TEST	Operation of electrical loads can be checked by sending drive signal to them.
	SELF-DIAG RESULTS	Displays BCM self-diagnosis results.
	CAN DIAG SUPPORT MNTR	The result of transmit/receive diagnosis of CAN communication can be read.
	ECU PART NUMBER	BCM part number can be read.
	CONFIGURATION	Performs BCM configuration read/write functions.

CONSULT-II OPERATION

CAUTION:

If CONSULT-II is used with no connection of CONSULT-II CONVERTER, malfunctions might be detected in self-diagnosis depending on control unit which carries out CAN communication.

1. With the ignition switch OFF, connect CONSULT-II and CONSULT-II CONVERTER to the data link connector, then turn the ignition switch ON.

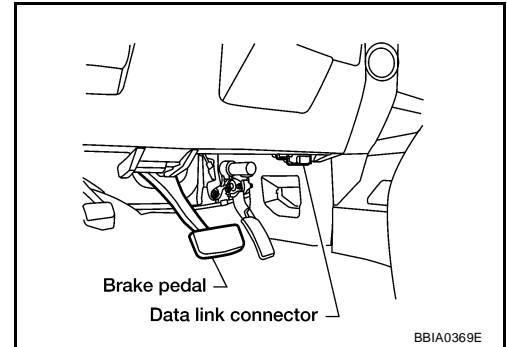

2. Touch "START (NISSAN BASED VHCL)".

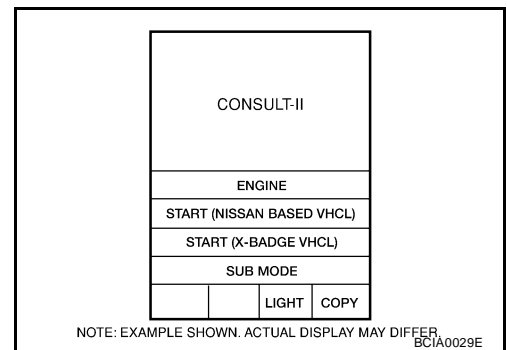

3. Touch "BCM" on the "SELECT SYSTEM" screen. If "BCM" is not indicated, go to [GI-39, "CONSULT-II Data Link Connector \(DLC\) Circuit"](#).

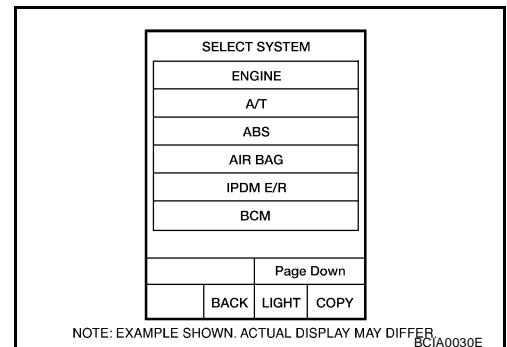

FRONT WIPER AND WASHER SYSTEM

4. Select the desired part to be diagnosed on the "SELECT TEST ITEM" screen.

SELECT TEST ITEM			
HEAD LAMP			
WIPER			
FLASHER			
AIR CONDITIONER			
COMB SW			
BCM			
Scroll Up		Page Down	
	BACK	LIGHT	COPY

LKIA0183E

WORK SUPPORT

Operation Procedure

1. Touch "WIPER" on the "SELECT TEST ITEM" screen.
2. Touch "WORK SUPPORT" on the "SELECT DIAG MODE" screen.
3. Touch "WIPER SPEED SETTING" on the "SELECT WORK ITEM" screen.
4. Touch "START".
5. Touch "CHANGE SETT".
6. The setting will be changed and "CUSTOMIZING COMPLETED" will be displayed.
7. Touch "END".

Work Support Setting Item

Item	Description	CONSULT-II
WIPER SPEED SETTING	When wiper switch is at INTERMITTENT, front wiper intermittent time can be selected according to vehicle speed. ● ON (Operated)/OFF (Not operated)	ON/OFF

DATA MONITOR

Operation Procedure

1. Touch "WIPER" on the "SELECT TEST ITEM" screen.
2. Touch "DATA MONITOR" on the "SELECT DIAG MODE" screen.
3. Touch either "ALL SIGNALS" or "SELECTION FROM MENU" on the "SELECT MONITOR ITEM" screen.

ALL SIGNALS	Monitors all the items.
SELECTION FROM MENU	Selects and monitors the individual item selected.

4. Touch "START".
5. When "SELECTION FROM MENU" is selected, touch items to be monitored. When "ALL SIGNALS" is selected, all the items will be monitored.
6. Touch "RECORD" while monitoring to record the status of the item being monitored. To stop recording, touch "STOP".

Display Item List

Monitor item name "OPERATION OR UNIT"	Contents
IGN ON SW "ON/OFF"	Displays "IGN Position (ON)/OFF, ACC Position (OFF)" status as judged from ignition switch signal.
IGN SW CAN "ON/OFF"	Displays "IGN switch ON (ON)/Other OFF or ACC (OFF)" status as judged from CAN communications.
FR WIPER HI "ON/OFF"	Displays "Front Wiper HI (ON)/Other (OFF)" status as judged from wiper switch signal.
FR WIPER LOW "ON/OFF"	Displays "Front Wiper LOW (ON)/Other (OFF)" status as judged from wiper switch signal.
FR WIPER INT "ON/OFF"	Displays "Front Wiper INT (ON)/Other (OFF)" status as judged from wiper switch signal.
FR WASHER SW "ON/OFF"	Displays "Front Washer Switch (ON)/Other (OFF)" status as judged from wiper switch signal.
INT VOLUME (1 - 7)	Displays intermittent operation dial position setting (1 - 7) as judged from wiper switch signal.

FRONT WIPER AND WASHER SYSTEM

Monitor item name "OPERATION OR UNIT"	Contents
FR WIPER STOP "ON/OFF"	Displays "Stopped (ON)/Operating (OFF)" status as judged from the auto-stop signal.
VEHICLE SPEED "0.0 km/h"	Displays vehicle speed as received from CAN communication.

ACTIVE TEST

Operation Procedure

1. Touch "WIPER" on the "SELECT TEST ITEM" screen.
2. Touch "ACTIVE TEST" on the "SELECT DIAG MODE" screen.
3. Touch item(s) to be tested and check operation of the selected item(s).
4. During the operation check, touching "BACK" deactivates the operation.

Display Item List

Test item	Display on CONSULT-II screen	Description
Front wiper HI output	FR WIPER (HI)	Front wiper HI can be operated by any ON-OFF operation.
Front wiper LO output	FR WIPER (LO)	Front wiper LO can be operated by any ON-OFF operation.
Front wiper INT output	FR WIPER (INT)	Front wiper INT can be operated by any ON-OFF operation.

CONSULT-II Function (IPDM E/R)

EKS00AEL

CONSULT-II can display each diagnostic item using the diagnostic test modes shown following.

IPDM E/R diagnostic Mode	Description
SELF-DIAG RESULTS	Displays IPDM E/R self-diagnosis results.
DATA MONITOR	Displays IPDM E/R input/output data in real time.
CAN DIAG SUPPORT MNTR	The result of transmit/receive diagnosis of CAN communication can be read.
ACTIVE TEST	Operation of electrical loads can be checked by sending drive signal to them.

CONSULT-II OPERATION

CAUTION:

If CONSULT-II is used with no connection of CONSULT-II CONVERTER, malfunctions might be detected in self-diagnosis depending on control unit which carries out CAN communication.

1. With the ignition switch OFF, connect CONSULT-II and CONSULT-II CONVERTER to the data link connector, then turn the ignition switch ON.

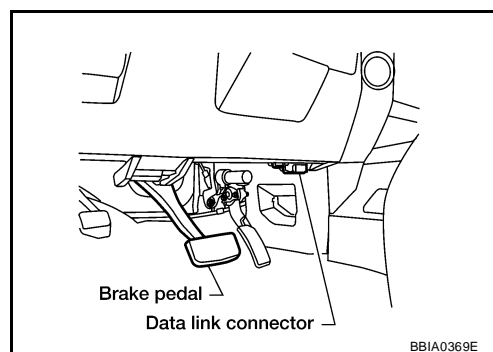

2. Touch "START (NISSAN BASED VHCL)".

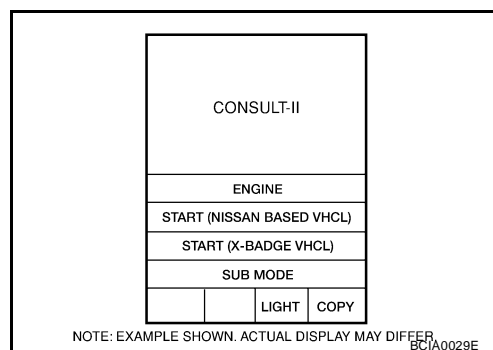

FRONT WIPER AND WASHER SYSTEM

- Touch "IPDM E/R" on the "SELECT SYSTEM" screen.
If "IPDM E/R" is not indicated, go to [GI-39, "CONSULT-II Data Link Connector \(DLC\) Circuit"](#).

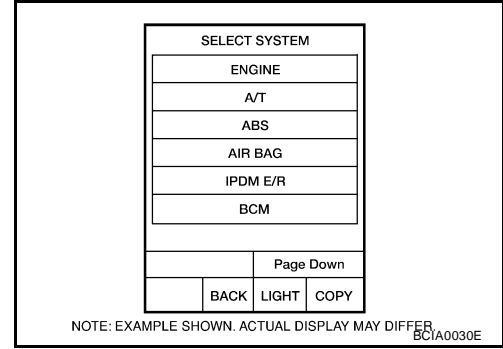

- Select the desired part to be diagnosed on the "SELECT DIAG MODE" screen.

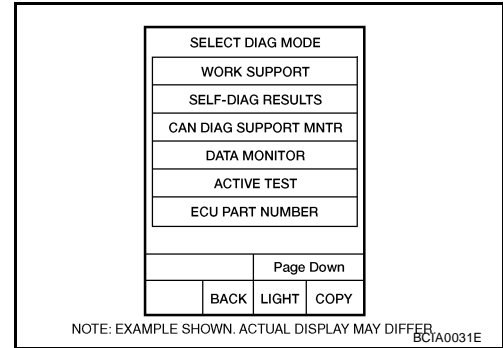

DATA MONITOR

Operation Procedure

- Touch "DATA MONITOR" on the "SELECT DIAG MODE" screen.
- Touch "ALL SIGNALS", "MAIN SIGNALS" or "SELECTION FROM MENU" on "SELECT MONITOR ITEM" screen.

ALL SIGNALS	Monitors all the items.
MAIN SIGNALS	Monitors predetermined items.
SELECTION FROM MENU	Selects and monitors the individual item selected.

- When "SELECTION FROM MENU" is selected, touch items to be monitored then touch "START". When "ALL SIGNALS" or "MAIN SIGNALS" is selected, all the displayed items will be monitored.
- Touch "RECORD" while monitoring to record the status of the item being monitored. To stop recording, touch "STOP".

All Signals, Main Signals, Selection From Menu

Item name	CONSULT-II screen display	Display or unit	Monitor item selection			Description
			ALL SIGNALS	MAIN SIGNALS	SELECTION FROM MENU	
Front wiper request	FR WIP REQ	STOP/1LOW/LOW/HI	x	x	x	Signal status input from BCM.
Wiper auto stop	WIP AUTO STOP	ACT P/STOP P	x	x	x	Output status of IPDM E/R.
Wiper protection	WIP PROT	OFF/LS/HS/BLOCK	x	x	x	Control status of IPDM E/R.

NOTE:

Perform monitoring of IPDM E/R data with the ignition switch ON. When the ignition switch is at ACC, the display may not be correct.

ACTIVE TEST

Operation Procedure

- Touch "ACTIVE TEST" on the "SELECT DIAG MODE" screen.

FRONT WIPER AND WASHER SYSTEM

2. Touch "FRONT WIPER" on the "SELECT TEST ITEM" screen.
3. Touch item(s) to be tested and check operation of the selected item(s).
4. During the operation check, touching "BACK" deactivates the operation.

Display Item List

Test item	CONSULT-II screen display	Description
Front wiper (HI, LO) output	FRONT WIPER	With a certain operation (OFF, HI, LO) front wiper relays can be operated.

A

B

C

D

E

F

G

H

I

J

WW

L

M

FRONT WIPER AND WASHER SYSTEM

EKS00AEM

Front Wiper Does Not Operate

CAUTION:

During IPDM E/R fail-safe control, front wipers may not operate. Refer to [PG-18, "CAN COMMUNICATION LINE CONTROL"](#) to make sure that it is not in fail-safe status.

Inspection Procedure

1. CHECK IPDM E/R TO FRONT WIPERS

☐ With CONSULT-II

1. Select "IPDM E/R" with CONSULT-II, and select "ACTIVE TEST" on "SELECT DIAG MODE" screen.
2. Select "FRONT WIPER" on "SELECT TEST ITEM" screen.
3. Confirm front wiper operation.

☒ Without CONSULT-II

1. Turn on front wipers using auto active test. Refer to [PG-24, "Auto Active Test"](#).
2. Confirm front wiper operation.

OK or NG

- OK >> GO TO 4.
NG >> GO TO 2.

ACTIVE TEST			
FRONT WIPER		OFF	
HI		LO	
MODE	BACK	LIGHT	COPY

SKIA3486E

FRONT WIPER AND WASHER SYSTEM

2. IPDM E/R TO FRONT WIPERS CIRCUIT INSPECTION

1. Turn ignition switch OFF.
2. Disconnect IPDM E/R connectors and front wiper motor connector.
3. Check continuity between IPDM E/R harness connector terminals and front wiper motor harness connector terminals.

Terminals				Continuity
Connector	Terminal	Connector	Terminal	
E121	32	E23	3	Yes
	35		2	
E122	43		6	

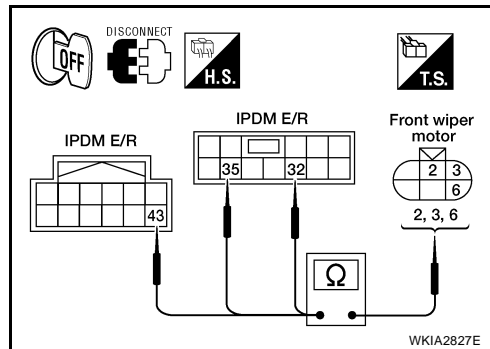

4. Check continuity between IPDM E/R harness connector terminals and ground.

Terminals				Continuity
Connector	Terminal			
E121	32	Ground		No
	35			
E122	43			

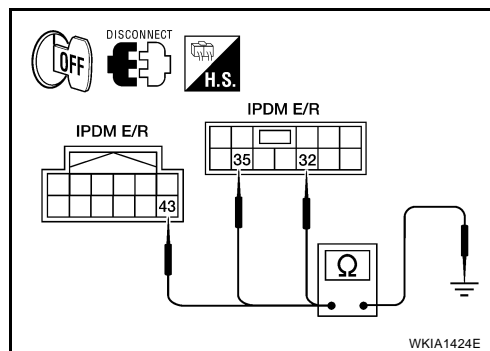

5. Check continuity between IPDM E/R harness connector terminal and ground.

Terminals				Continuity
Connector	Terminal			
E122	38	Ground		Yes
E124	59			

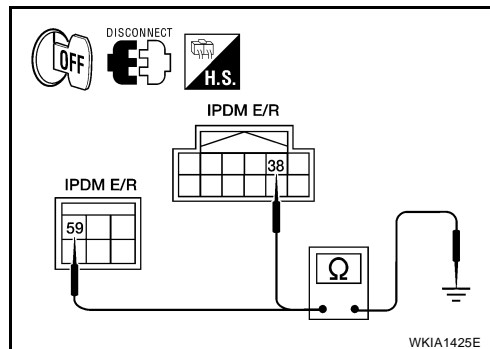

6. Check continuity between front wiper motor harness connector terminal 1 and ground.

Terminals				Continuity
Connector	Terminal			
E23	1	Ground		Yes

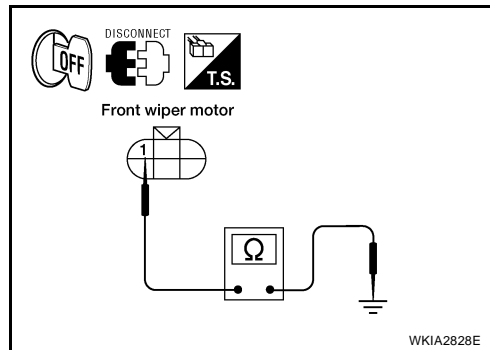

OK or NG

- OK >> Connect connectors. GO TO 3.
- NG >> Check for open circuit in harness between front wiper motor and ground.

FRONT WIPER AND WASHER SYSTEM

3. IPDM E/R INSPECTION

☑ With CONSULT-II

1. Select "HI" on "ACTIVE TEST" screen.
2. When front wiper relay, and front wiper HI relay are operating, check voltage between IPDM E/R terminals and ground.

☒ Without CONSULT-II

1. Turn on front wipers using the auto active test. Refer to [PG-24, "Auto Active Test"](#).
2. When front wiper relay, and front wiper HI relay are operating, check voltage between IPDM E/R terminals and ground.

Terminals		(-)	Condition	Voltage (Approx.)
(+)	Terminal			
E121	32	Ground	Stopped	0
			LO operation	Battery voltage
	35		Stopped	0
			HI operation	Battery voltage

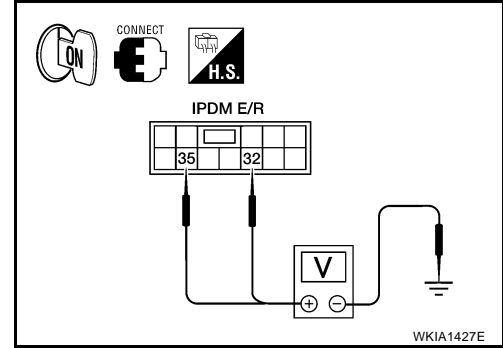

OK or NG

- OK >> Replace the front wiper motor. Refer to [WW-29, "REMOVAL AND INSTALLATION"](#).
- NG >> Replace IPDM E/R. Refer to [PG-31, "Removal and Installation of IPDM E/R"](#).

4. COMBINATION SWITCH TO BCM INSPECTION

Select "BCM" on CONSULT-II. With "WIPER" data monitor, check that "FR WIPER INT", "FR WIPER LOW" and "FR WIPER HI" turn ON-OFF according to operation of wiper switch.

OK or NG

- OK >> GO TO 5.
- NG >> Check wiper switch. Refer to [WW-5, "COMBINATION SWITCH READING FUNCTION"](#).

DATA MONITOR	
MONITOR	
IGN ON SW	OFF
IGN SW CAN	ON
FR WIPER HI	OFF
FR WIPER LOW	OFF
FR WIPER INT	OFF
FR WASHER SW	OFF
INT VOLUME	7
FR WIPER STOP	ON
VEHICLE SPEED	0.0 km/h
PAGE DOWN	
RECORD	
MODE	BACK
LIGHT	COPY

WKIA1018E

5. BCM INSPECTION

Select "BCM" on CONSULT-II. Carry out self-diagnosis of BCM.

Displayed self-diagnosis results

- NO DTC>> Replace the BCM. Refer to [BCS-20, "BCM"](#).
- CAN COMM CIRCUIT>> Check CAN communication line of BCM.
GO TO [BCS-13, "CAN Communication Inspection Using CONSULT-II \(Self-Diagnosis\)"](#).

SELF-DIAG RESULTS			
DTC RESULTS		TIME	
CAN COMM CIRCUIT [U1000]		PAST	
ERASE		PRINT	
MODE	BACK	LIGHT	COPY

SKIA1039E

FRONT WIPER AND WASHER SYSTEM

FRONT WIPER STOP POSITION IS INCORRECT

1. CHECK IPDM E/R TO FRONT WIPER MOTOR

Ⓜ With CONSULT-II

Select "IPDM E/R" with CONSULT-II. With data monitor, confirm that "WIP AUTO STOP" changes from "ACT P" to "STOP P" according to wiper operation.

ⓧ Without CONSULT-II

GO TO 2.

OK or NG

OK >> Replace IPDM E/R. Refer to [PG-31, "Removal and Installation of IPDM E/R"](#).

NG >> GO TO 2.

DATA MONITOR	
MONITOR	
MOTOR FAN REQ	1
AC COMP REQ	OFF
TAIL&CLR REQ	OFF
HL LO REQ	OFF
HL HI REQ	OFF
FR FOG REQ	OFF
FR WIP REQ	STOP
WIP AUTO STOP	STOP P
WIP PROT	OFF
Page DOWN	
RECORD	
MODE	BACK
LIGHT	COPY

SKIA5301E

2. IPDM E/R TO FRONT WIPER MOTOR CIRCUIT INSPECTION

- Turn ignition switch OFF.
- Disconnect IPDM E/R connector and front wiper motor connector.
- Check continuity between IPDM E/R harness connector and front wiper motor harness connector.

Terminals				Continuity
Connector	Terminal	Connector	Terminal	
E122	43	E23	6	Yes

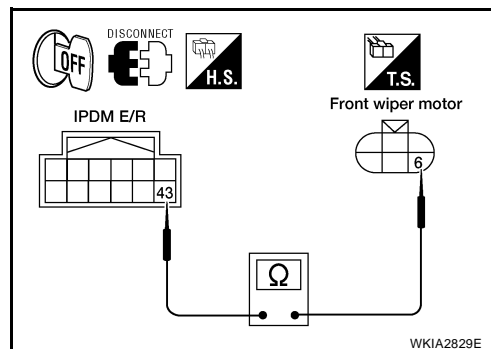

- Check continuity between IPDM E/R harness connector terminal and ground.

Terminals			Continuity
Connector	Terminal		
E122	43	Ground	No

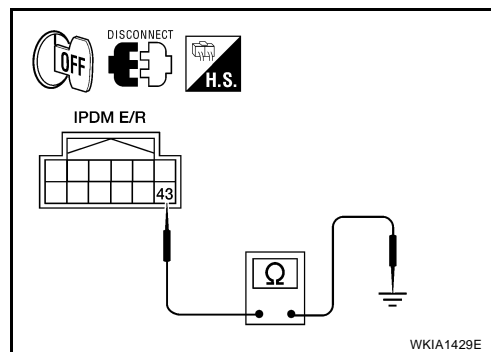

- Check continuity between front wiper motor harness connector terminal 1 and ground.

Terminals			Continuity
Connector	Terminal		
E23	1	Ground	Yes

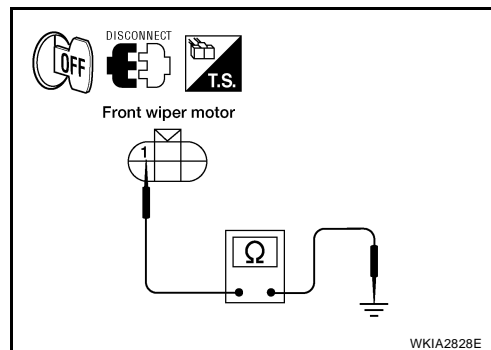

OK or NG

OK >> GO TO 3.

NG >> ● Check for short circuit or open circuit in harness between IPDM E/R and front wiper motor.

- Check for open circuit in harness between front wiper motor and ground.

FRONT WIPER AND WASHER SYSTEM

3. IPDM E/R INSPECTION

☑ With CONSULT-II

1. Connect IPDM E/R connector and front wiper motor connector.
2. Select "IPDM E/R" with CONSULT-II, and select "ACTIVE TEST" on "SELECT DIAG MODE" screen.
3. Select "FRONT WIPER" on "SELECT TEST ITEM" screen.
4. Select "LO" on "ACTIVE TEST" screen.
5. When front wipers are operating and when stopped, measure voltage between IPDM E/R terminal 43 and ground.

☒ Without CONSULT-II

1. Connect IPDM E/R connector and front wiper motor connector.
2. Turn on front wipers using the auto active test. Refer to [PG-24, "Auto Active Test"](#).
3. When front wipers are operating and when stopped, measure voltage between IPDM E/R terminal 43 and ground.

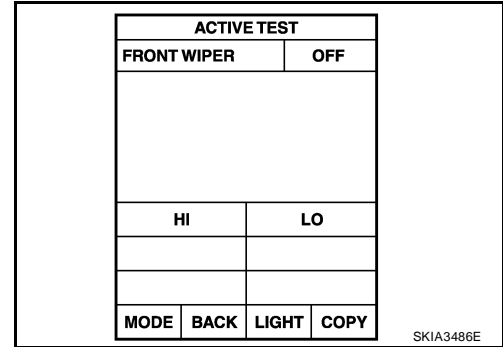

Terminals		(-)	Condition	Voltage (Approx.)
(+)	Terminal			
Connector		Ground	Wiper operating	Battery voltage
E122	43		Wiper stopped	0V

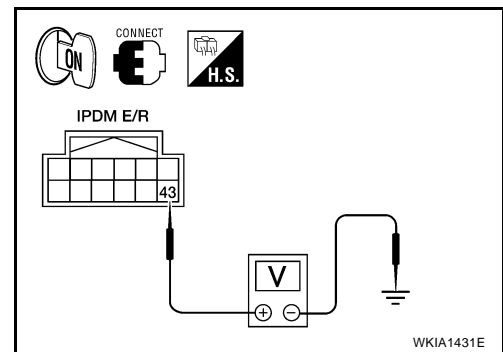

OK or NG

- OK >> Replace IPDM E/R. Refer to [PG-31, "Removal and Installation of IPDM E/R"](#).
 NG >> Replace front wiper motor. Refer to [WW-29, "REMOVAL AND INSTALLATION"](#).

ONLY FRONT WIPER LOW DOES NOT OPERATE

1. CHECK IPDM E/R TO FRONT WIPERS

☑ With CONSULT-II

1. Select "IPDM E/R" with CONSULT-II, and select "ACTIVE TEST" on "SELECT DIAG MODE" screen.
2. Select "FRONT WIPER" on "SELECT TEST ITEM" screen.
3. Select "LO" on "ACTIVE TEST" screen.
4. Confirm front wiper low operation.

☒ Without CONSULT-II

1. Turn on front wipers using auto active test. Refer to [PG-24, "Auto Active Test"](#).
2. Confirm front wiper low operation.

OK or NG

- OK >> GO TO 4.
 NG >> GO TO 2.

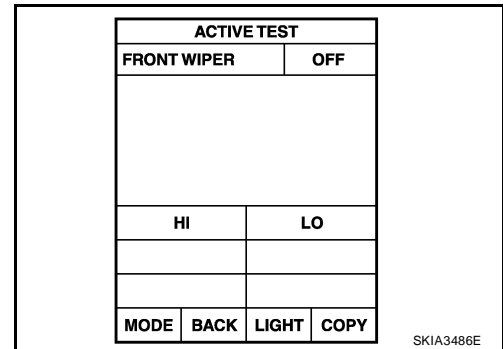

FRONT WIPER AND WASHER SYSTEM

2. IPDM E/R INSPECTION

④ With CONSULT-II

1. Select "LO" on "ACTIVE TEST" screen.

⊗ Without CONSULT-II

1. Turn on front wipers using the auto active test. Refer to [PG-24, "Auto Active Test"](#).

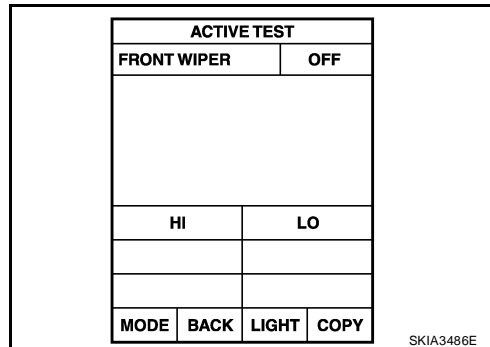

When front wiper relay is operating, check voltage between IPDM E/R terminal and ground.

Terminals				Voltage (Approx.)
(+)		(-)	Condition	
Connector	Terminal			
E121	32	Ground	Wiper operating	Battery voltage

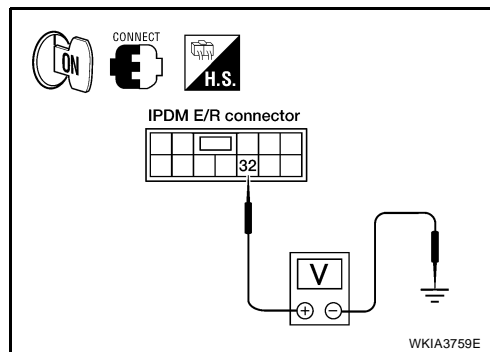

OK or NG

OK >> GO TO 3.

NG >> Replace IPDM E/R. Refer to [PG-31, "Removal and Installation of IPDM E/R"](#).

3. IPDM E/R TO FRONT WIPERS CIRCUIT INSPECTION

1. Turn ignition switch OFF.
2. Disconnect IPDM E/R connector and front wiper motor connector.
3. Check continuity between IPDM E/R harness connector terminal and front wiper motor harness connector terminal.

Terminals				Continuity
Connector	Terminal	Connector	Terminal	
E121	32	E23	3	Yes

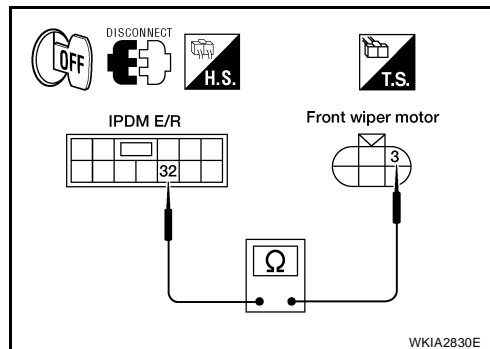

OK or NG

OK >> Replace the wiper motor. Refer to [WW-29, "REMOVAL AND INSTALLATION"](#).

NG >> Repair harness or connector.

4. COMBINATION SWITCH TO BCM INSPECTION

Select "BCM" on CONSULT-II. With "WIPER" data monitor, check that "FR WIPER LOW" turns ON-OFF according to operation of wiper switch.

OK or NG

OK >> Replace BCM. Refer to [BCS-20, "BCM"](#).

NG >> Replace wiper switch. Refer to [WW-30, "REMOVAL AND INSTALLATION"](#).

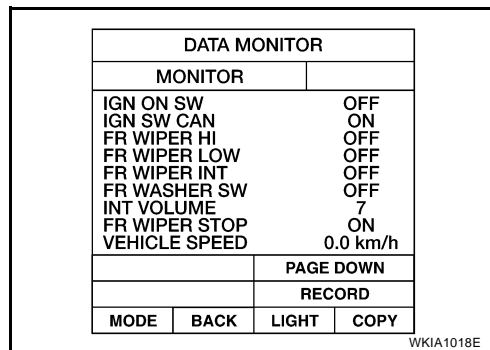

FRONT WIPER AND WASHER SYSTEM

ONLY FRONT WIPER HI DOES NOT OPERATE

1. CHECK IPDM E/R TO FRONT WIPERS

Ⓟ With CONSULT-II

1. Select "IPDM E/R" with CONSULT-II, and select "ACTIVE TEST" on "SELECT DIAG MODE" screen.
2. Select "FRONT WIPER" on "SELECT TEST ITEM" screen.
3. Select "HI" on "ACTIVE TEST" screen.
4. Confirm front wiper high operation.

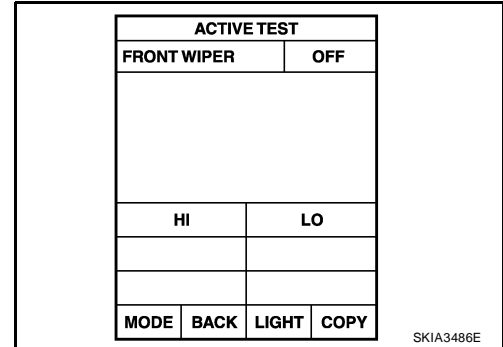

ⓧ Without CONSULT-II

1. Turn on front wipers using auto active test. Refer to [PG-24, "Auto Active Test"](#).
2. Confirm front wiper operation.

OK or NG

- OK >> GO TO 4.
- NG >> GO TO 2.

2. IPDM E/R INSPECTION

Ⓟ With CONSULT-II

1. Select "HI" on "ACTIVE TEST" screen.

ⓧ Without CONSULT-II

1. Turn on front wipers using the auto active test. Refer to [PG-24, "Auto Active Test"](#).

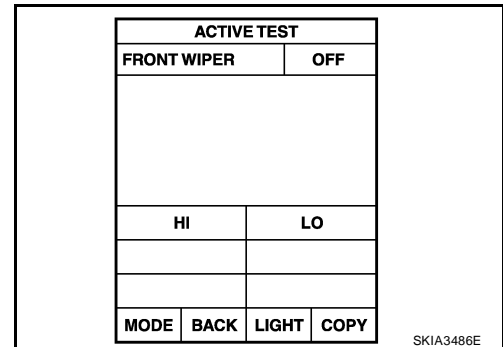

When front wiper relay high is operating, check voltage between IPDM E/R terminal and ground.

Terminals				Voltage (Approx.)
(+)		(-)	Condition	
Connector	Terminal			
E121	35	Ground	Wiper operating	Battery voltage

OK or NG

- OK >> GO TO 3.
- NG >> Replace IPDM E/R. Refer to [PG-31, "Removal and Installation of IPDM E/R"](#).

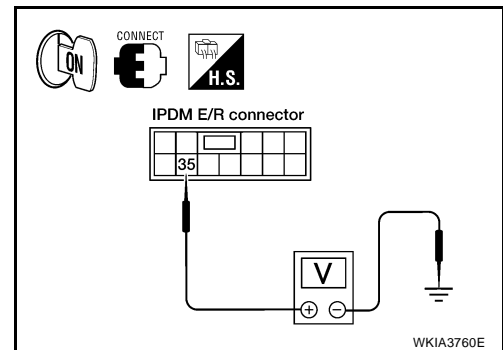

FRONT WIPER AND WASHER SYSTEM

3. IPDM E/R TO FRONT WIPERS CIRCUIT INSPECTION

1. Turn ignition switch OFF.
2. Disconnect IPDM E/R connector and front wiper motor connector.
3. Check continuity between IPDM E/R harness connector terminal and front wiper motor harness connector terminal.

Terminals				Continuity
Connector	Terminal	Connector	Terminal	
E121	35	E23	2	Yes

OK or NG

- OK >> Replace the wiper motor. Refer to [WW-29, "REMOVAL AND INSTALLATION"](#) .
- NG >> Repair harness or connector.

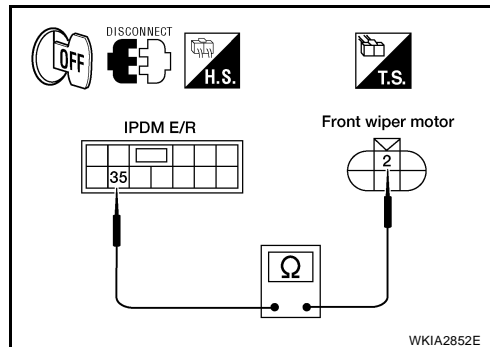

4. COMBINATION SWITCH TO BCM INSPECTION

Select "BCM" on CONSULT-II. With "WIPER" data monitor, check that "FR WIPER HI" turns ON-OFF according to operation of wiper switch.

OK or NG

- OK >> Replace BCM. Refer to [BCS-20, "BCM"](#) .
- NG >> Replace wiper switch. Refer to [WW-30, "REMOVAL AND INSTALLATION"](#) .

DATA MONITOR	
MONITOR	
IGN ON SW	OFF
IGN SW CAN	ON
FR WIPER HI	OFF
FR WIPER LOW	OFF
FR WIPER INT	OFF
FR WASHER SW	OFF
INT VOLUME	7
FR WIPER STOP	ON
VEHICLE SPEED	0.0 km/h
PAGE DOWN	
RECORD	
MODE	BACK LIGHT COPY

ONLY FRONT WIPER INTERMITTENT DOES NOT OPERATE

1. COMBINATION SWITCH TO BCM INSPECTION

Select "BCM" on CONSULT-II. With "WIPER" data monitor, check that "FR WIPER INT" turns ON-OFF according to operation of wiper switch.

OK or NG

- OK >> Replace BCM. Refer to [BCS-20, "BCM"](#) .
- NG >> Replace wiper switch. Refer to [WW-30, "REMOVAL AND INSTALLATION"](#) .

DATA MONITOR	
MONITOR	
IGN ON SW	OFF
IGN SW CAN	ON
FR WIPER HI	OFF
FR WIPER LOW	OFF
FR WIPER INT	OFF
FR WASHER SW	OFF
INT VOLUME	7
FR WIPER STOP	ON
VEHICLE SPEED	0.0 km/h
PAGE DOWN	
RECORD	
MODE	BACK LIGHT COPY

FRONT WIPER AND WASHER SYSTEM

FRONT WIPER INTERMITTENT OPERATION SWITCH POSITION CANNOT BE ADJUSTED

1. COMBINATION SWITCH TO BCM INSPECTION

Select "BCM" on CONSULT-II. With "WIPER" data monitor, check that "INT VOLUME" changes in order from 1 to 7 according to operation of the intermittent switch dial position.

OK or NG

- OK >> Replace BCM. Refer to [BCS-20, "BCM"](#).
- NG >> Replace wiper switch. Refer to [WW-30, "REMOVAL AND INSTALLATION"](#).

DATA MONITOR			
MONITOR			
IGN ON SW		OFF	
IGN SW CAN		ON	
FR WIPER HI		OFF	
FR WIPER LOW		OFF	
FR WIPER INT		OFF	
FR WASHER SW		OFF	
INT VOLUME		7	
FR WIPER STOP		ON	
VEHICLE SPEED		0.0 km/h	
		PAGE DOWN	
		RECORD	
MODE	BACK	LIGHT	COPY

WKIA1018E

WIPERS DO NOT WIPER WHEN FRONT WASHER OPERATES

1. COMBINATION SWITCH TO BCM INSPECTION

Select "BCM" on CONSULT-II. With "WIPER" data monitor, check that "FR WASHER SW" turns ON-OFF according to operation of front washer switch.

OK or NG

- OK >> Replace BCM. Refer to [BCS-20, "BCM"](#).
- NG >> Replace wiper switch. Refer to [WW-30, "REMOVAL AND INSTALLATION"](#).

DATA MONITOR			
MONITOR			
IGN ON SW		OFF	
IGN SW CAN		ON	
FR WIPER HI		OFF	
FR WIPER LOW		OFF	
FR WIPER INT		OFF	
FR WASHER SW		OFF	
INT VOLUME		7	
FR WIPER STOP		ON	
VEHICLE SPEED		0.0 km/h	
		PAGE DOWN	
		RECORD	
MODE	BACK	LIGHT	COPY

WKIA1018E

FRONT WIPERS OPERATE FOR 10 SECONDS, STOP FOR 20 SECONDS, AND AFTER REPEATING THIS OPERATION FIVE TIMES, THEY BECOME INOPERATIVE

CAUTION:

- When auto stop signal has not varied for 10 seconds or longer while IPDM E/R is operating front wipers, IPDM E/R considers front wipers locked and stops wiper output, which causes this symptom.
- This status can be checked by using IPDM E/R "DATA MONITOR". Under this condition, "WIP PROT" reads "BLOCK".

1. CHECK IPDM E/R TO FRONT WIPER MOTOR

Ⓜ With CONSULT-II

Select "IPDM E/R" with CONSULT-II. With data monitor, confirm that "WIP AUTO STOP" changes from "ACT P" to "STOP P" according to wiper operation.

ⓧ Without CONSULT-II

GO TO 2.

OK or NG

- OK >> Replace IPDM E/R. Refer to [PG-31, "Removal and Installation of IPDM E/R"](#).
- NG >> GO TO 2.

DATA MONITOR			
MONITOR			
MOTOR FAN REQ		1	
AC COMP REQ		OFF	
TAIL&CLR REQ		OFF	
HL LO REQ		OFF	
HL HI REQ		OFF	
FR FOG REQ		OFF	
FR WIP REQ		STOP	
WIP AUTO STOP		STOP P	
WIP PROT		OFF	
		Page DOWN	
		RECORD	
MODE	BACK	LIGHT	COPY

SKIA5301E

FRONT WIPER AND WASHER SYSTEM

2. IPDM E/R TO FRONT WIPER MOTOR CIRCUIT INSPECTION

1. Turn ignition switch OFF.
2. Disconnect IPDM E/R connector and front wiper motor connector.
3. Check continuity between IPDM E/R harness connector terminal and front wiper motor harness connector terminal.

Terminals				Continuity
Connector	Terminal	Connector	Terminal	
E122	43	E23	6	Yes

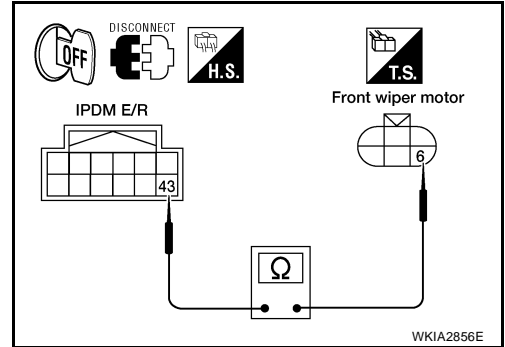

4. Check continuity between IPDM E/R harness connector terminal and ground.

Terminals			Continuity
Connector	Terminal		
E122	43	Ground	No

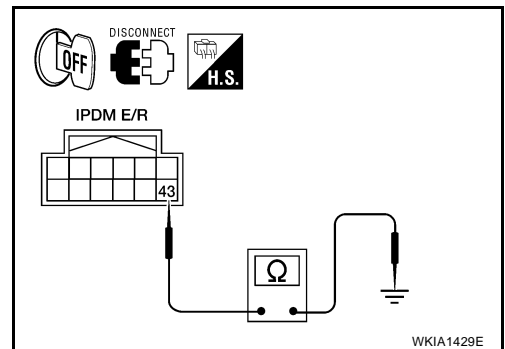

OK or NG

- OK >> Connect connectors. GO TO 3.
- NG >> Repair harness or connector.

3. IPDM E/R TO FRONT WIPER MOTOR AUTO STOP CIRCUIT INSPECTION

While front wiper motor is stopped and while operating, measure voltage between IPDM E/R terminal 43 and ground.

Terminals				Voltage (Approx.)
(+)		(-)	Condition	
Connector	Terminal			
E122	43	Ground	Wiper operating	Battery voltage
			Wiper stopped	0V

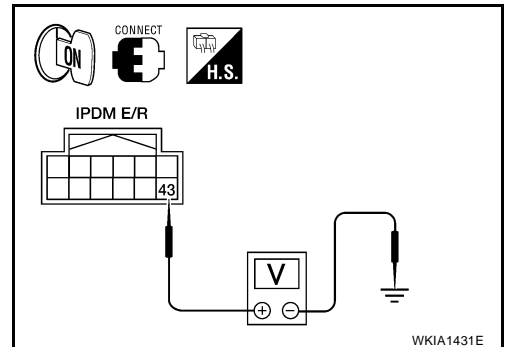

OK or NG

- OK >> Replace IPDM E/R. Refer to [PG-31, "Removal and Installation of IPDM E/R"](#).
- NG >> Replace front wiper motor. Refer to [WW-29, "REMOVAL AND INSTALLATION"](#).

FRONT WIPER AND WASHER SYSTEM

EKS00GDS

Front Wiper Arms REMOVAL AND INSTALLATION

Removal

1. Remove wiper arm covers and wiper arm nuts.
2. Remove front RH wiper arm and front LH wiper arm.
3. Remove front RH blade assembly and front LH blade assembly.

Installation

1. Operate wiper motor one full cycle, then turn "OFF" (Auto Stop).
2. Clean up the pivot area as shown. This will reduce possibility of wiper arm looseness.

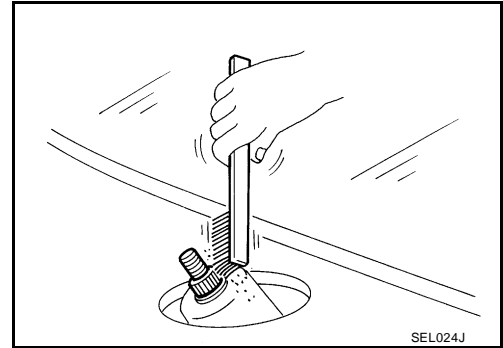

3. Install front RH blade assembly and front LH blade assembly.
4. Install front RH wiper arm and front LH wiper arm.
5. Tighten wiper arm nuts to specified torque, and install wiper arm covers.

Front wiper arm nuts : 23.6 N·m (2.4 kg·m, 17 ft·lb)

6. Ensure that wiper blades stop within proper clearance. Refer [WW-28, "FRONT WIPER ARM ADJUSTMENT"](#).

FRONT WIPER ARM ADJUSTMENT

1. Operate windshield washer and wiper motor one full cycle, then turn "OFF" (Auto Stop).
2. Lift the wiper blade up and then rest it onto glass surface, check the blade clearance "L1" and "L2".

Clearance "L1" : 41.5 - 56.5 mm (1.634 - 2.224 in)

Clearance "L2" : 52.5 - 67.5 mm (2.067 - 2.657 in)

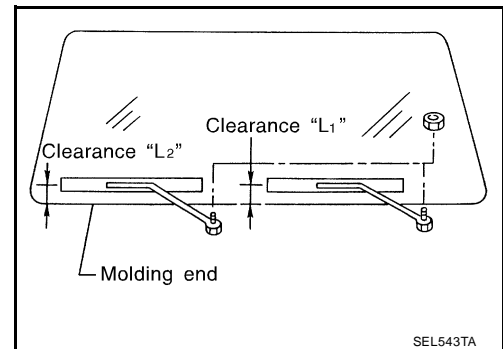

3. Remove wiper arm covers and wiper arm nuts.
4. Adjust front wiper arms on wiper motor pivot shafts to obtain above specified blade clearances.
5. Tighten wiper arm nuts to specified torque, and install wiper arm covers.

Front wiper arm nuts : 23.6 N·m (2.4 kg·m, 17 ft·lb)

FRONT WIPER AND WASHER SYSTEM

Wiper Motor and Linkage REMOVAL AND INSTALLATION

EKS00GDT

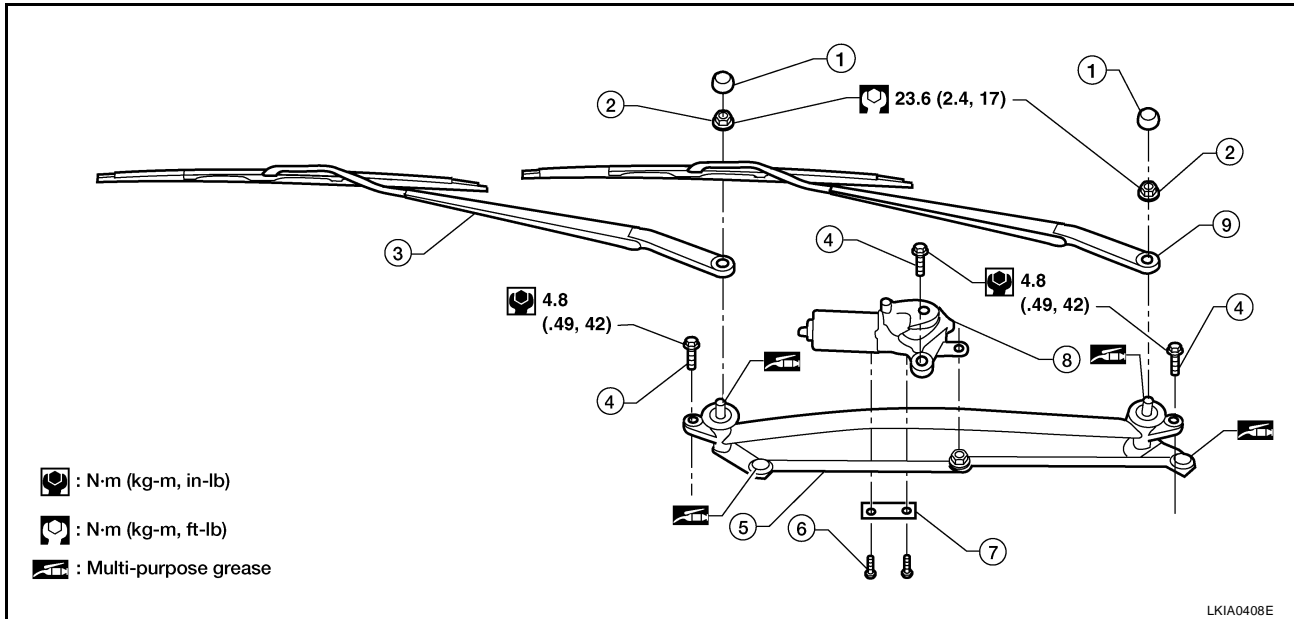

- | | | |
|-----------------------|-------------------------|--|
| 1. Wiper arm covers | 2. Wiper arm nuts | 3. Front RH wiper arm and blade assembly |
| 4. Wiper frame bolts | 5. Wiper frame assembly | 6. Wiper motor to frame bolts |
| 7. Wiper motor spacer | 8. Wiper motor | 9. Front LH wiper arm and blade assembly |

REMOVAL

1. Remove the cowl top. Refer to [EI-21, "COWL TOP"](#).
2. Remove wiper frame bolts, and remove wiper frame assembly.
3. Remove wiper motor from wiper frame assembly.

INSTALLATION

CAUTION:

- Do not drop the wiper motor or cause it to contact other parts.
 - Check the grease condition of the motor arm and wiper link joint(s). Apply grease if necessary.
1. Connect wiper motor to connector. Turn the wiper switch ON to operate wiper motor, then turn the wiper switch OFF (auto stop).
 2. Disconnect wiper motor connector.
 3. Install wiper motor to wiper frame assembly, and install wiper frame assembly.
 4. Install cowl top. Refer to [EI-21, "COWL TOP"](#).
 5. Ensure that wiper blades stop within proper clearance. Refer to front wiper arm adjustment [WW-28, "FRONT WIPER ARM ADJUSTMENT"](#).

Washer Nozzle Adjustment

- This vehicle is equipped with non-adjustable washer nozzles.
- If not satisfied with washer fluid spray coverage, confirm that the washer nozzle is installed correctly.
- If the washer nozzle is installed correctly, and the washer fluid spray coverage is not satisfactory, replace washer nozzle.

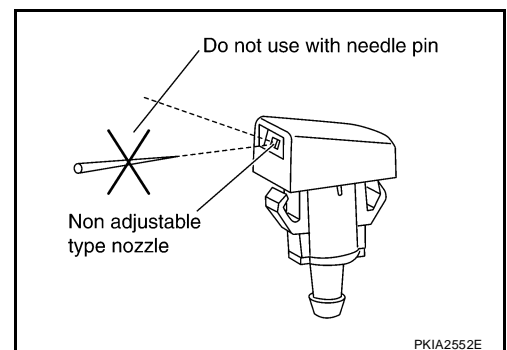

EKS00GDU

PKIA2552E

FRONT WIPER AND WASHER SYSTEM

Washer Tube Layout

EKS00GDV

SEC. 289

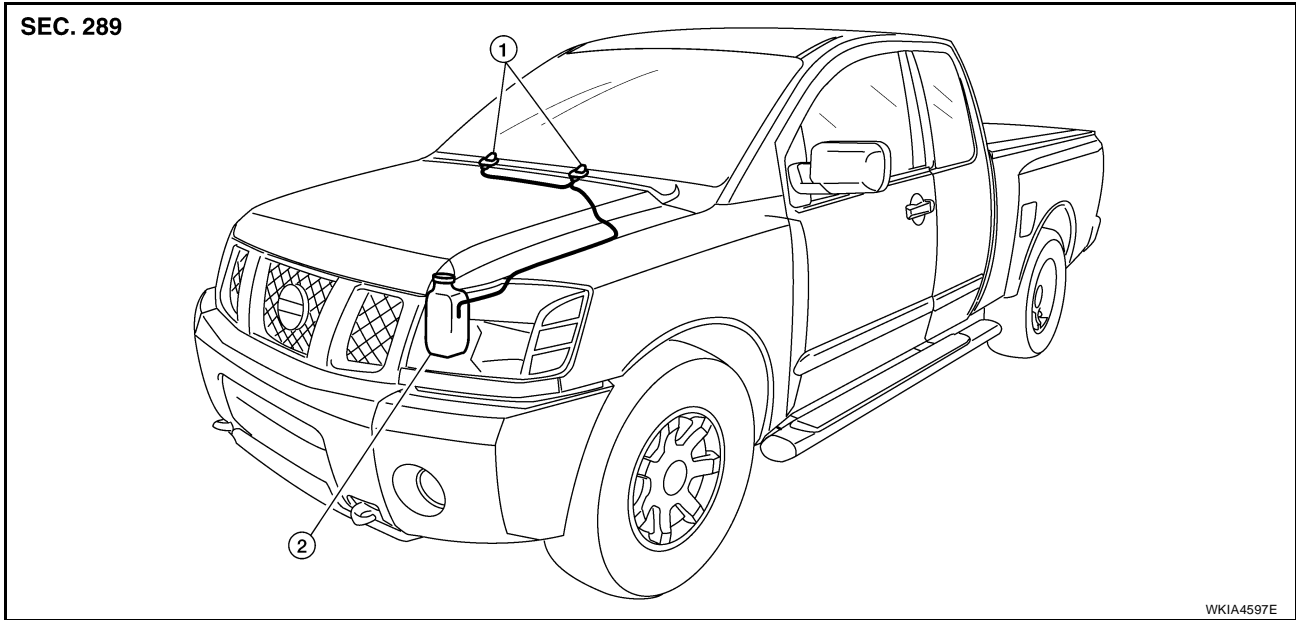

WKIA4597E

1. Washer nozzles

2. Washer fluid reservoir

Wiper and Washer Switch REMOVAL AND INSTALLATION

EKS00GDW

Removal

1. Remove steering column covers.
2. Remove wiper washer switch connector.
3. Pinch tabs at wiper and washer switch base and slide switch away from steering column to remove.

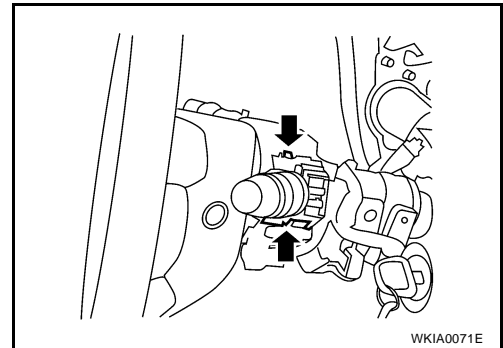

WKIA0071E

INSTALLATION

Installation is in the reverse order of removal.

Washer Fluid Reservoir REMOVAL AND INSTALLATION

EKS00GDY

Removal

1. Remove side washer fluid reservoir screw.

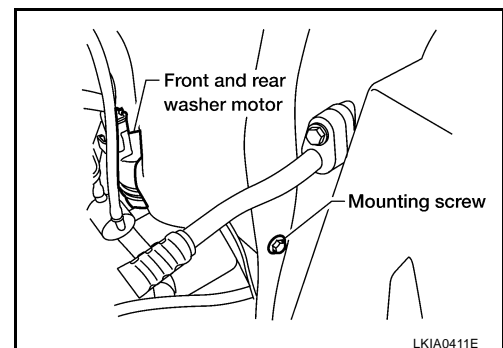

LKIA0411E

2. Remove front and rear washer motor connector.

FRONT WIPER AND WASHER SYSTEM

3. Remove washer fluid level sensor connector.
4. Disconnect front and rear washer hoses.

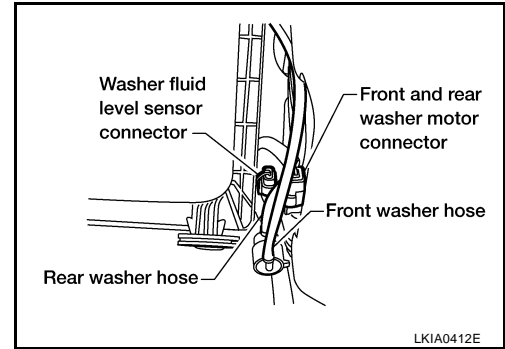

5. Remove front washer fluid reservoir screw (2).
6. Remove washer fluid reservoir from the vehicle (1).

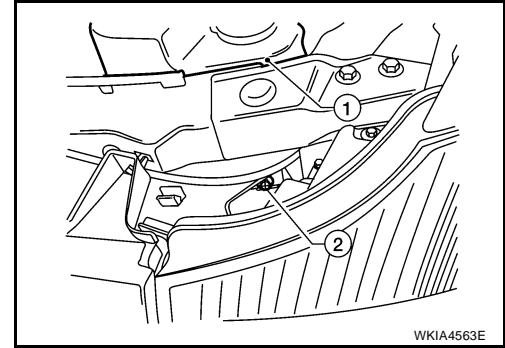

Installation

Installation is in the reverse order of removal.

CAUTION:

After installation, add water up to the upper level of the washer fluid reservoir inlet and check for water leaks.

Washer Motor REMOVAL AND INSTALLATION

EKS00GDY

Removal

1. Remove washer fluid reservoir. Refer to [WW-30, "Washer Fluid Reservoir"](#).
2. Remove washer motor (1) in the direction of the arrow as shown, from washer fluid reservoir (2).

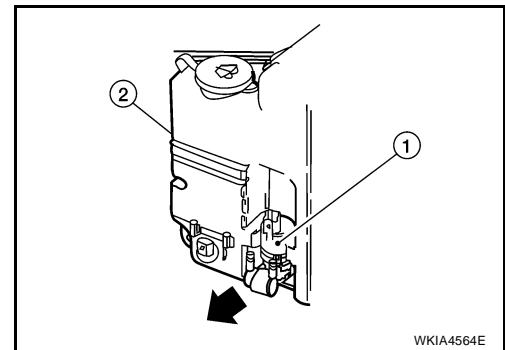

INSTALLATION

CAUTION:

When installing front and rear washer motor, there should be no packing twists, etc.

Installation is in the reverse order of removal.

A
B
C
D
E
F
G
H
I
J
L
M

WW

CIGARETTE LIGHTER

PF:35330

CIGARETTE LIGHTER

Wiring Diagram — CIGAR —

EKS00H0G

WW-CIGAR-01

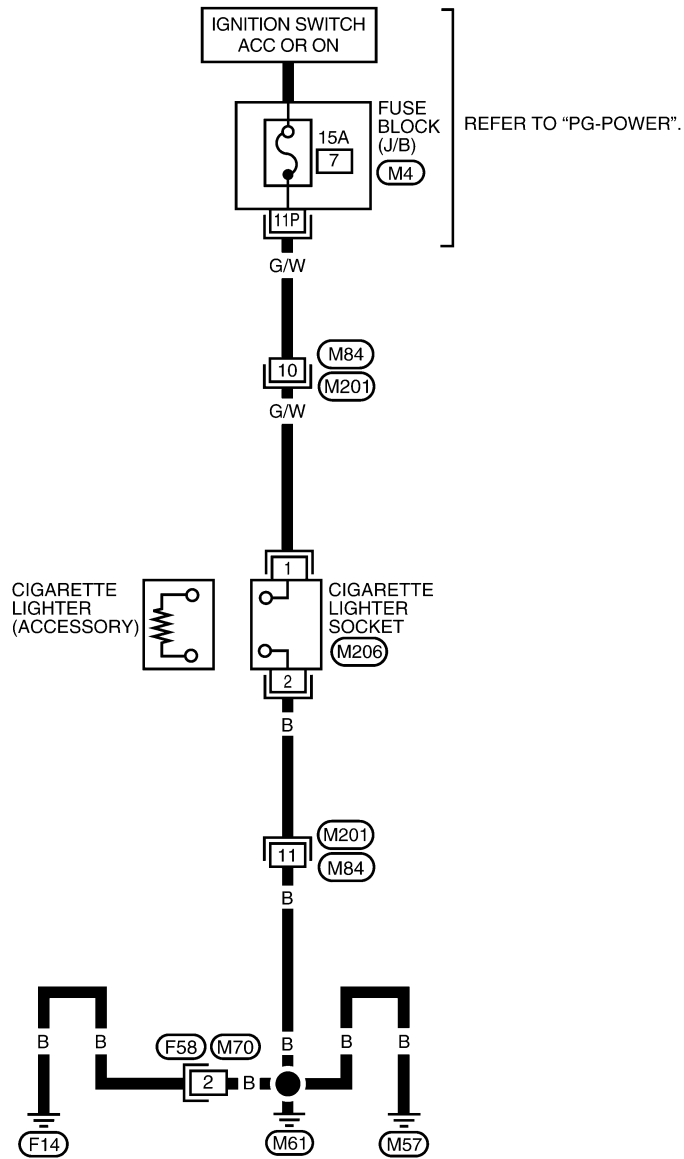

WKWA1357E

CIGARETTE LIGHTER

Removal and Installation

EKS00H0H

1. Remove the A/T finisher. Refer to [IP-13, "A/T FINISHER"](#) .
2. Remove console box finisher. Refer to [IP-15, "Center Console"](#) .
3. Remove socket.
4. Press out ring from the back of console box finisher.

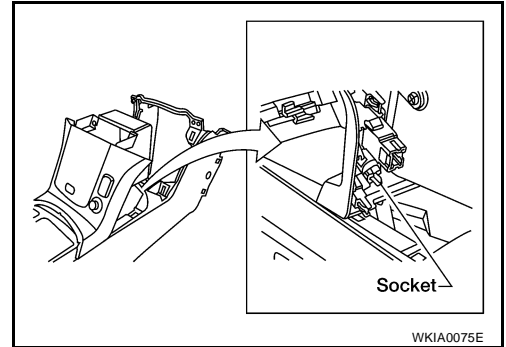

A

B

C

D

E

F

G

H

I

J

WW

L

M

POWER SOCKET

PPF:253A2

POWER SOCKET

Wiring Diagram — P/SCKT —

EKS00H01

WW-P/SCKT-01

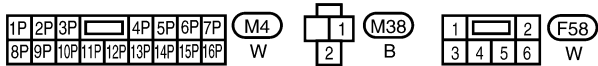
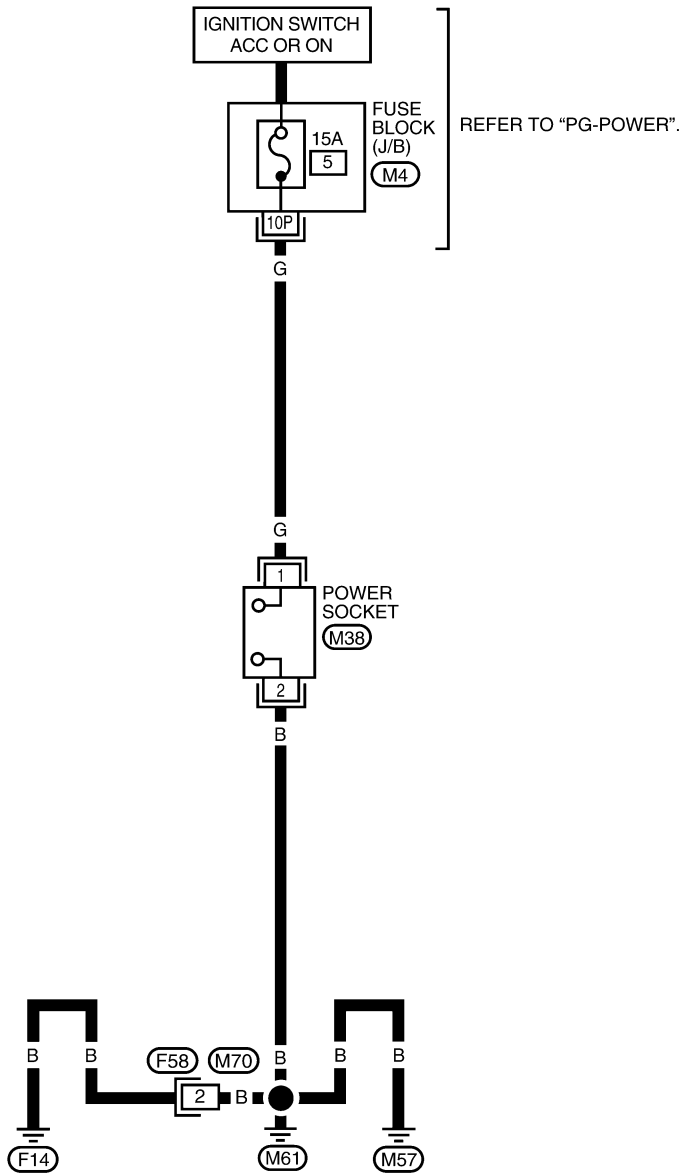

WKWA1358E

POWER SOCKET

Removal and Installation

1. Remove the console finisher. Refer to [IP-15, "Center Console"](#) .
2. Disconnect power socket connector.
3. Remove socket from the console.

EKS00H0J

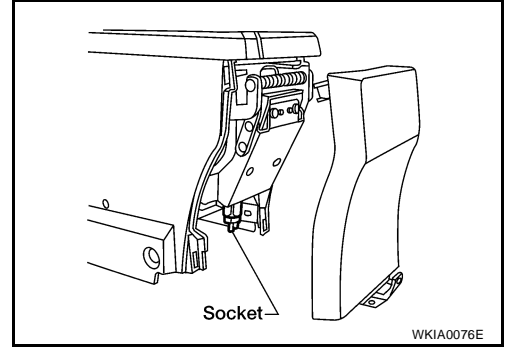

A

B

C

D

E

F

G

H

I

J

WW

L

M

HORN

PF2:25610

HORN

Wiring Diagram — HORN —

EKS00H0K

WW-HORN-01

 : WITH VEHICLE SECURITY SYSTEM

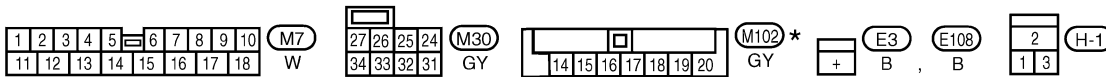
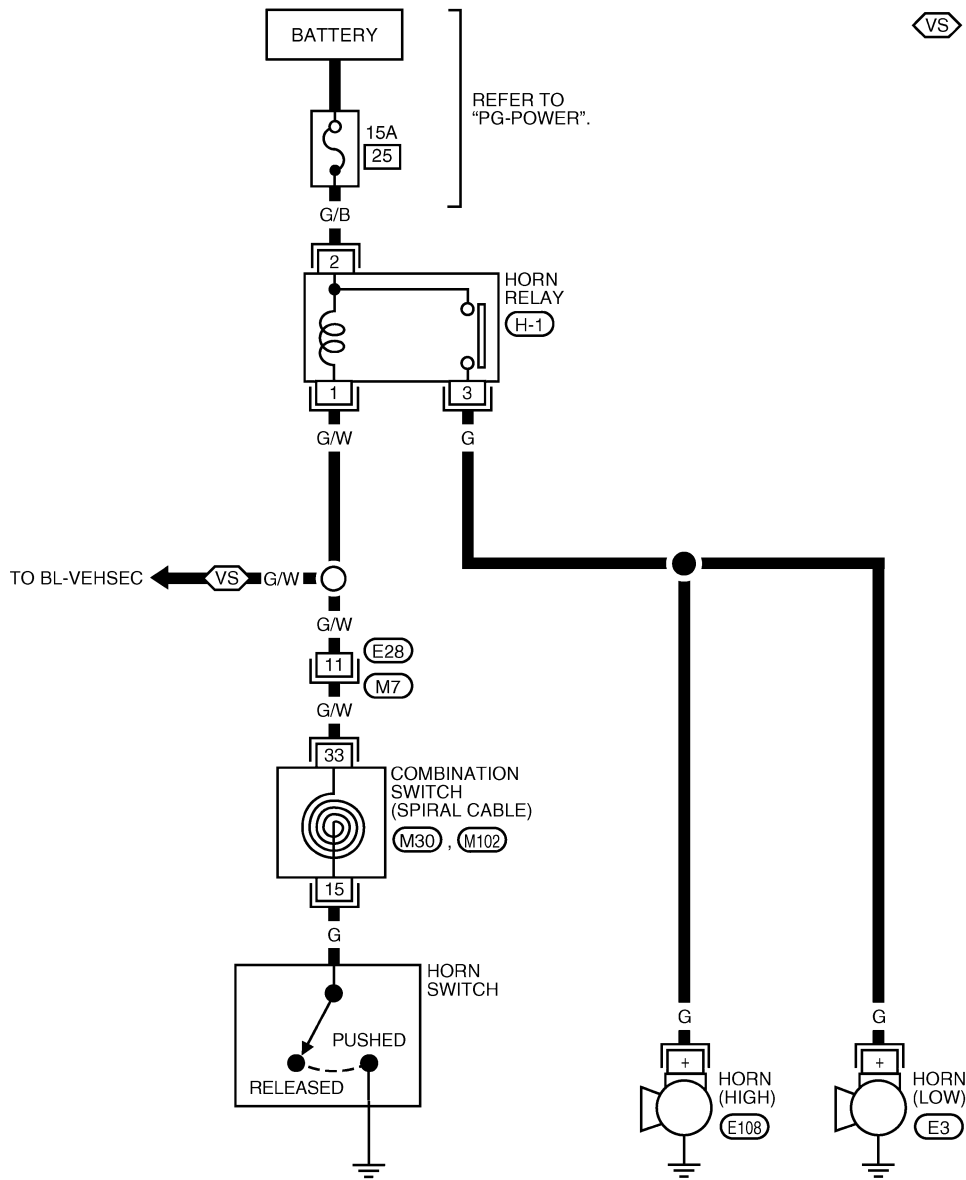

*: THIS CONNECTOR IS NOT SHOWN IN "HARNESS LAYOUT" OF PG SECTION.

WKWA1359E

HORN

EKS00H0L

Removal and Installation

REMOVAL (HORN HIGH)

1. Remove right headlamp. Refer to [LT-31, "Removal and Installation"](#).
2. Disconnect horn connector.
3. Remove horn.

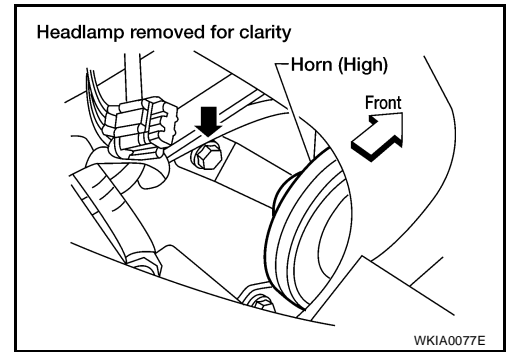

INSTALLATION (HORN HIGH)

Tighten horn bolt to specified torque.

Horn bolt : 17 N·m (1.7 kg-m, 12.3 ft-lb)

1. Reconnect horn connector.
2. Install right headlamp. Refer to [LT-31, "Removal and Installation"](#).

REMOVAL (HORN LOW)

1. Remove left headlamp. Refer to [LT-31, "Removal and Installation"](#).
2. Disconnect horn connector.
3. Remove horn.

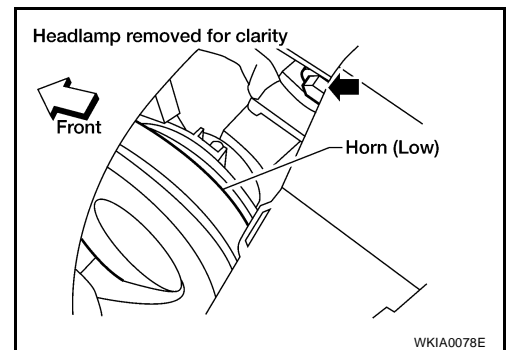

INSTALLATION (HORN LOW)

Tighten horn bolt to specified torque.

Horn bolt : 17 N·m (1.7 kg-m, 12.3 ft-lb)

1. Reconnect horn connector.
2. Install left headlamp, refer to [LT-31, "Removal and Installation"](#).

A
B
C
D
E
F
G
H
I
J
L
M

WW

HORN
