

**SECTION** **AP**  
**ADJUSTABLE PEDAL**

A  
B  
C  
D  
E  
F  
G  
H  
I  
AP  
K  
L  
M  
N  
O  
P

**CONTENTS**

<b>BASIC INSPECTION</b> .....	2	Pedal Adjusting Switch Power Supply and Ground Circuit Inspection (Floor Shift) .....	10
<b>DIAGNOSIS AND REPAIR WORKFLOW</b> .....	2	Pedal Adjusting Switch Power Supply and Ground Circuit Inspection (Column Shift) .....	11
Repair Work Flow .....	2	Pedal Adjusting Motor Circuit Inspection .....	12
<b>INSPECTION AND ADJUSTMENT</b> .....	4	<b>ECU DIAGNOSIS</b> .....	14
Preliminary Check .....	4	<b>ADJUSTABLE PEDAL SYSTEM</b> .....	14
<b>FUNCTION DIAGNOSIS</b> .....	5	Reference Value .....	14
<b>ADJUSTABLE PEDAL SYSTEM</b> .....	5	Wiring Diagram .....	15
Automatic Drive Positioner Interlocking Adjustable Pedal .....	5	<b>SYMPTOM DIAGNOSIS</b> .....	19
System Diagram .....	5	<b>ADJUSTABLE PEDAL SYSTEM</b> .....	19
Component Parts Location .....	5	Symptom Table .....	19
Component Description .....	6	<b>PRECAUTION</b> .....	20
<b>COMPONENT DIAGNOSIS</b> .....	7	<b>PRECAUTIONS</b> .....	20
<b>ADJUSTABLE PEDAL SYSTEM</b> .....	7	Precaution for Supplemental Restraint System (SRS) "AIR BAG" and "SEAT BELT PRE-TENSIONER" .....	20
Pedal Adjusting Control Unit Ignition Signal Circuit .....	7	Precaution for Work .....	20
Pedal Adjusting Control Unit Output Power Supply .....	7	<b>ON-VEHICLE REPAIR</b> .....	21
A/T Device (Park Position Switch) Circuit Inspection (Floor Shift) .....	8	<b>ADJUSTABLE PEDAL SYSTEM</b> .....	21
A/T Device (Park Position Switch) Circuit Inspection (Column Shift) .....	9	Removal and Installation .....	21

# DIAGNOSIS AND REPAIR WORKFLOW

< BASIC INSPECTION >

## BASIC INSPECTION

### DIAGNOSIS AND REPAIR WORKFLOW

Repair Work Flow

INFOID:000000001665437

WORK FLOW

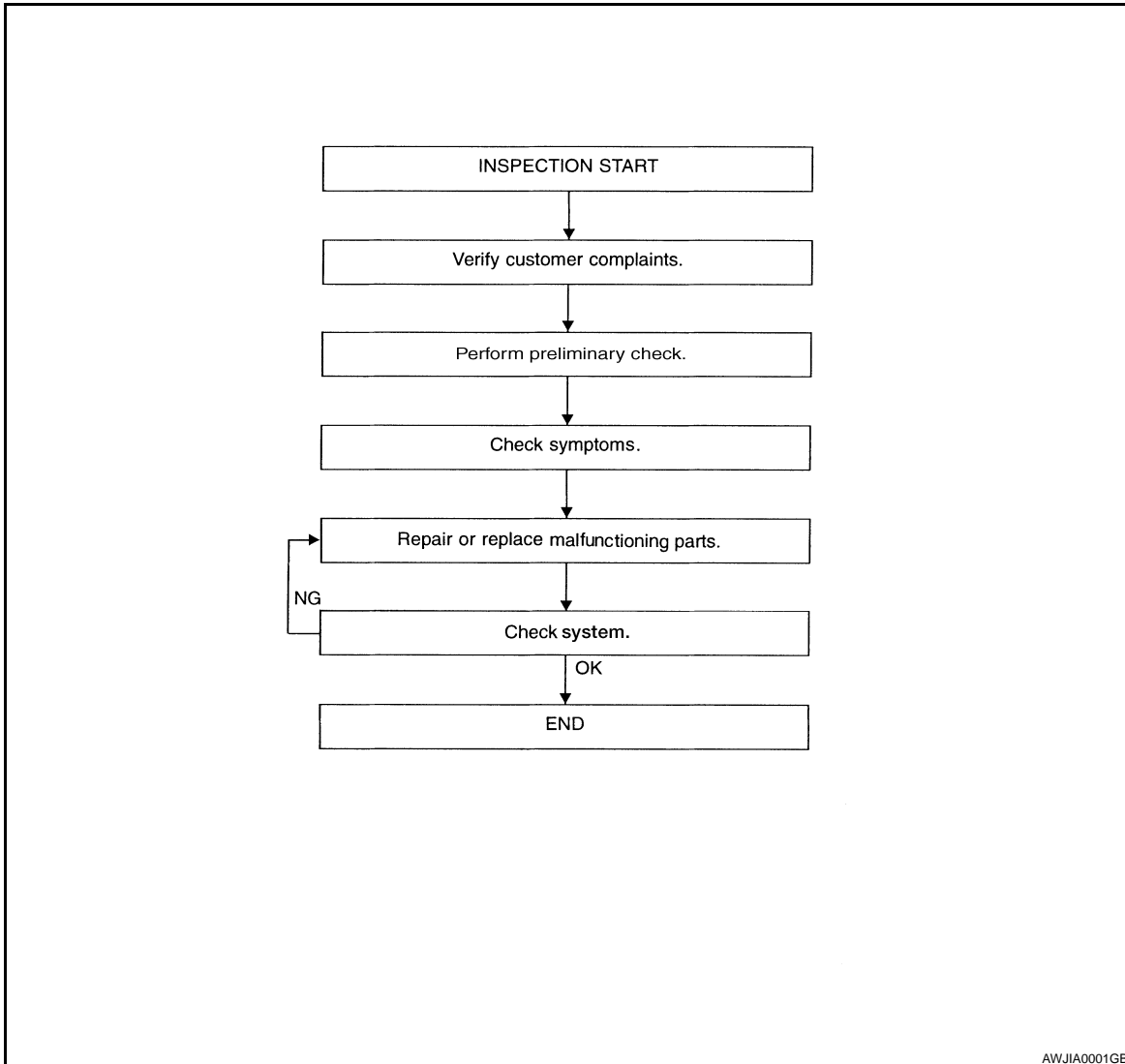

DETAILED FLOW

#### 1. CUSTOMER INFORMATION

Talk to the customer to obtain detailed information about the symptom.

>> GO TO 2

#### 2. PRELIMINARY CHECK

Perform preliminary check. Refer to [AP-4, "Preliminary Check"](#).

>> GO TO 3

#### 3. SYMPTOM

Check for symptoms. Refer to [AP-19, "Symptom Table"](#).

# DIAGNOSIS AND REPAIR WORKFLOW

< BASIC INSPECTION >

---

>> GO TO 4

## 4. MALFUNCTIONING PARTS

---

Repair or replace the applicable parts.

>> GO TO 5

## 5. SYSTEM CHECK

---

Operate the pedal adjusting switch to ensure that the pedals move completely forward and backward.

Does the system operate normally?

YES >> Inspection End.

NO >> Refer to [GI-41, "Intermittent Incident"](#).

A

B

C

D

E

F

G

H

I

AP

K

L

M

N

O

P

# INSPECTION AND ADJUSTMENT

< BASIC INSPECTION >

---

## INSPECTION AND ADJUSTMENT

### Preliminary Check

INFOID:000000001665438

### 1. FOREIGN OBJECTS

---

Check the following:

- objects on or behind the pedals that could cause binding

Are there any foreign objects that could be causing interference with the pedals?

YES >> Remove objects.

NO >> GO TO 2

### 2. WIRING CONNECTIONS

---

1. Disconnect pedal adjusting control unit and pedal adjusting motor.
2. Check terminals for damage or loose connections.
3. Reconnect harness connectors.

Are any connectors damaged or loose?

YES >> Repair or replace damaged parts.

NO >> GO TO 3

### 3. POWER AND GROUND

---

Check power supply and ground circuits for pedal adjusting control unit. Refer to [AP-10. "Pedal Adjusting Switch Power Supply and Ground Circuit Inspection \(Floor Shift\)"](#).

Is the inspection result normal?

YES >> Refer to [AP-19. "Symptom Table"](#).

NO >> Repair or replace as necessary.

# ADJUSTABLE PEDAL SYSTEM

< FUNCTION DIAGNOSIS >

## FUNCTION DIAGNOSIS

### ADJUSTABLE PEDAL SYSTEM

#### Automatic Drive Positioner Interlocking Adjustable Pedal

INFOID:000000001665439

Automatic drive positioner interlocking adjustable pedal. Refer to [ADP-9, "AUTOMATIC DRIVE POSITIONER SYSTEM : System Description"](#).

#### System Diagram

INFOID:000000001665440

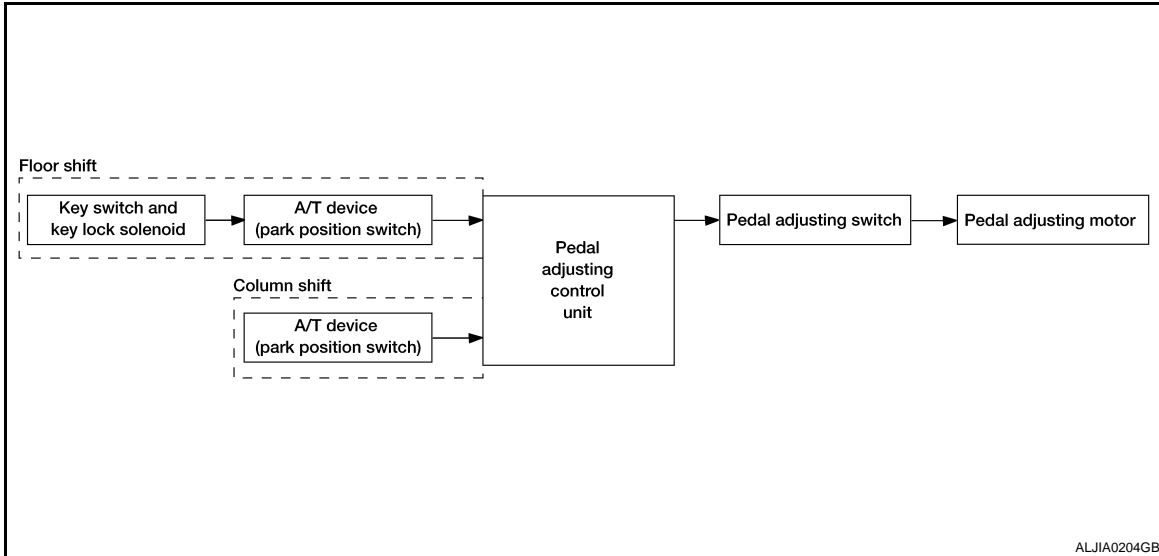

#### Component Parts Location

INFOID:000000001665441

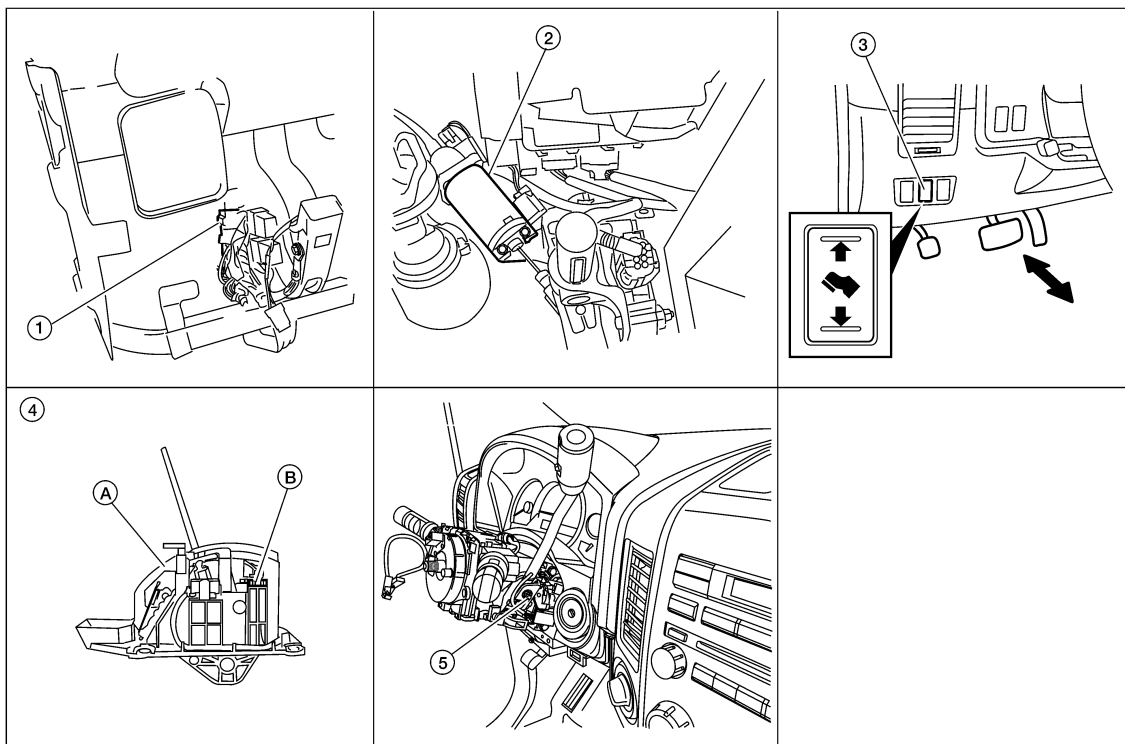

LIA2437E

# ADJUSTABLE PEDAL SYSTEM

## < FUNCTION DIAGNOSIS >

---

1. Pedal adjusting control unit M14  
(view with steering member removed LH)
2. Pedal adjusting motor E109
3. Pedal adjusting switch M96
4. A. A/T device  
B. A/T device (park position switch)  
(floor shift) M203
5. A/T device (park position switch)  
(column shift) M68

## Component Description

INFOID:000000001665442

Component	Function
Pedal adjusting control unit	<ul style="list-style-type: none"><li>• Receive inputs from pedal adjusting switch and A/T device (park position switch)</li><li>• Drive pedal adjusting motor</li></ul>
A/T device (park position switch)	Provide park position switch signal to pedal adjusting control unit
Pedal adjusting switch	Provide move forward/backward signals to pedal adjusting control unit
Pedal adjusting motor	<ul style="list-style-type: none"><li>• Move pedal assembly forward and backward</li><li>• Provide feedback signals to pedal adjusting control unit</li></ul>

# ADJUSTABLE PEDAL SYSTEM

< COMPONENT DIAGNOSIS >

## COMPONENT DIAGNOSIS

### ADJUSTABLE PEDAL SYSTEM

#### Pedal Adjusting Control Unit Ignition Signal Circuit

INFOID:000000001665443

#### 1. CHECK FUSE

Check for blown fuse.

Unit	Power source	Fuse No.	Location
Pedal adjusting control unit	Ignition switch ON or START	12	Fuse block (J/B)

#### Is fuse blown?

- YES >> Replace fuse after repairing applicable circuit.  
 NO >> GO TO 2

#### 2. CHECK PEDAL ADJUSTING CONTROL UNIT IGNITION SIGNAL CIRCUIT

1. Disconnect pedal adjusting control unit.
2. Check voltage between pedal adjusting control unit connector and ground.

Connector	Terminals		Condition	Voltage (V) (Approx.)
	(+)	(-)		
M14	4	Ground	Ignition switch ON	Battery voltage
			Ignition switch OFF	0

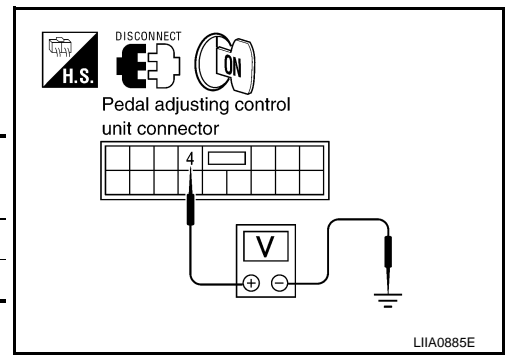

#### Is inspection result normal?

- YES >> Pedal adjusting control unit ignition signal is OK.  
 NO >> Repair or replace harness.

#### Pedal Adjusting Control Unit Output Power Supply

INFOID:000000001665444

#### 1. CHECK PEDAL ADJUSTING CONTROL UNIT OUTPUT POWER SUPPLY

1. Turn ignition switch OFF.
2. With key inserted and A/T selector lever in P position, check voltage between pedal adjusting control unit connector M14 terminal 7 and ground.

**7 - Ground : Battery voltage**

#### Is inspection result normal?

- YES >> Pedal adjusting control unit power supply and ground is OK.  
 NO >> GO TO 2

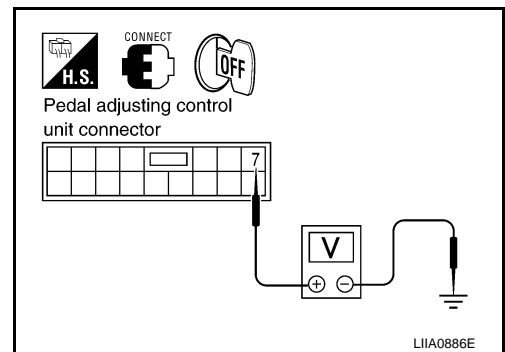

#### 2. CHECK PEDAL ADJUSTING CONTROL UNIT POWER SUPPLY CIRCUIT

1. Disconnect pedal adjusting control unit.
2. Check voltage between pedal adjusting control unit connector M14 terminal 5 and ground.

**5 - Ground : Battery voltage**

#### Is inspection result normal?

- YES >> GO TO 3  
 NO >> Repair or replace harness.

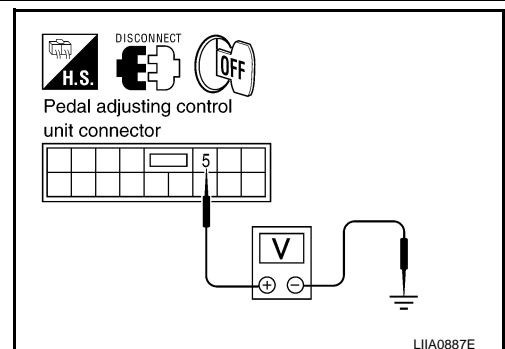

# ADJUSTABLE PEDAL SYSTEM

## < COMPONENT DIAGNOSIS >

### 3. CHECK PEDAL ADJUSTING CONTROL UNIT GROUND CIRCUIT

Check continuity between pedal adjusting control unit connector M14 terminal 1 and ground.

**1 - Ground : Continuity should exist.**

Is inspection result normal?

- YES >> Replace pedal adjusting control unit.
- NO >> Repair or replace harness.

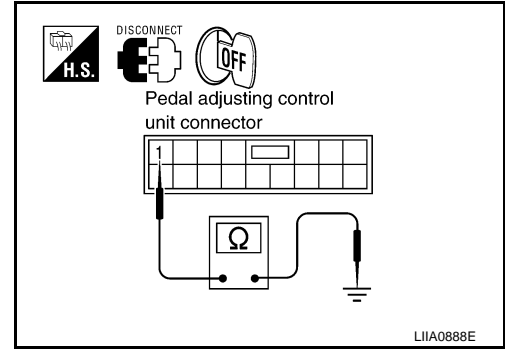

### A/T Device (Park Position Switch) Circuit Inspection (Floor Shift)

INFOID:000000001665445

#### 1. CHECK PEDAL ADJUSTING CONTROL UNIT INPUT SIGNAL

1. Turn ignition switch OFF.
2. Disconnect pedal adjusting control unit.
3. With key inserted in ignition cylinder, check voltage between pedal adjusting control unit connector and ground.

Connector	Terminals		Condition	Voltage (V) (Approx.)
	(+)	(-)		
M14	3	Ground	P position	Battery voltage
			Other than P position	0

Is inspection result normal?

- YES >> A/T device circuit is OK.
- NO >> GO TO 2

#### 2. CHECK A/T DEVICE POWER SUPPLY CIRCUIT

1. Disconnect A/T device.
2. Check voltage between A/T device connector M203 terminal 5 and ground.

**5 - Ground : Battery voltage**

Is inspection result normal?

- YES >> GO TO 3
- NO >> Repair or replace harness.

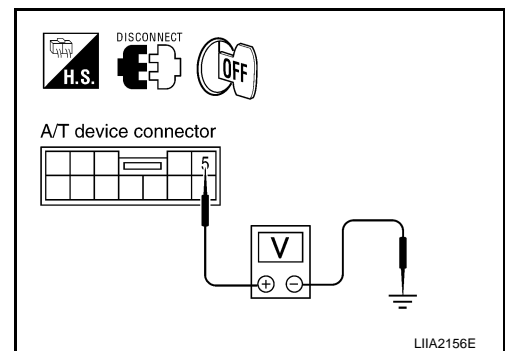
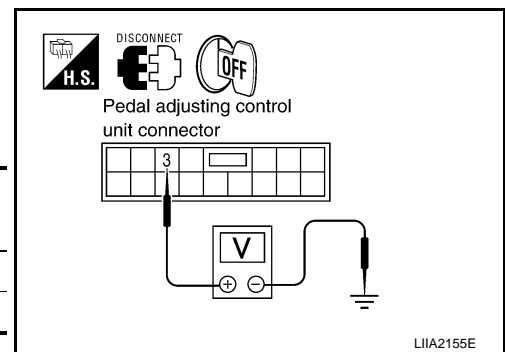

#### 3. CHECK A/T DEVICE HARNESS

1. Disconnect pedal adjusting control unit.
2. Check continuity between pedal adjusting control unit connector M14 terminal 3 and A/T device connector M203 terminal 6.

**3 - 6 : Continuity should exist.**

3. Check continuity between pedal adjusting control unit connector M14 terminal 3 and ground.

**3 - Ground : Continuity should not exist.**

Is inspection result normal?

- YES >> GO TO 4
- NO >> Repair or replace harness.

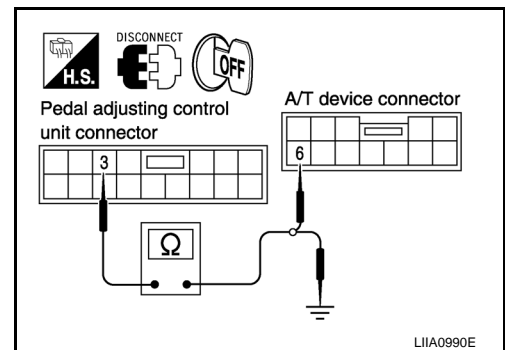



# ADJUSTABLE PEDAL SYSTEM

## < COMPONENT DIAGNOSIS >

### 4. CHECK A/T DEVICE

Check continuity between A/T device terminals as follows.

Terminals		Condition	Continuity
5	6	P position	Yes
		Other than P position	No

Is inspection result normal?

- YES >> Inspect shift lock system. Refer to [TM-217, "Checking of A/T Position"](#).
- NO >> Replace A/T device. Refer to [TM-215, "Control Device Removal and Installation"](#).

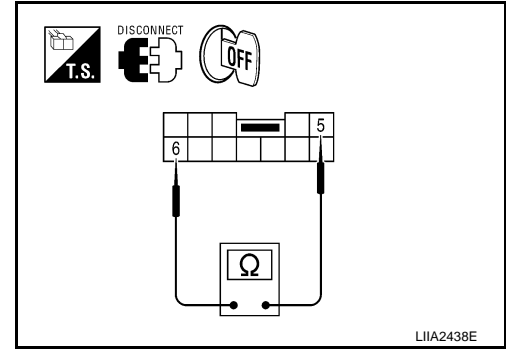

### A/T Device (Park Position Switch) Circuit Inspection (Column Shift)

INFOID:000000001665464

#### 1. CHECK PEDAL ADJUSTING CONTROL UNIT INPUT SIGNAL

- Turn ignition switch OFF.
- Disconnect pedal adjusting control unit.
- Check continuity between pedal adjusting control unit connector and ground.

Connector	Terminals		Condition	Continuity
M14	3	Ground	P position	Yes
			Other than P position	No

Is the inspection result normal?

- YES >> A/T device (park position switch) circuit is OK.
- NO >> GO TO 2

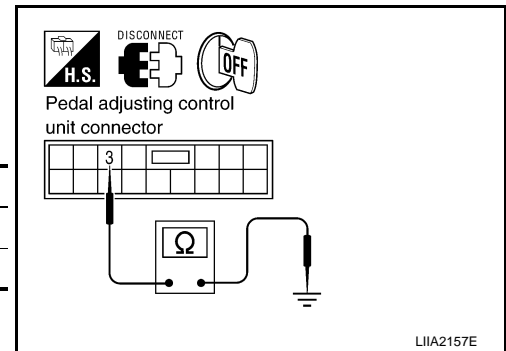

#### 2. CHECK A/T DEVICE GROUND CIRCUIT

- Disconnect A/T device.
- Check continuity between A/T device connector M68 terminal 1 and ground.

**1 - Ground : Continuity should exist.**

Is the inspection result normal?

- YES >> GO TO 3
- NO >> Repair or replace harness.

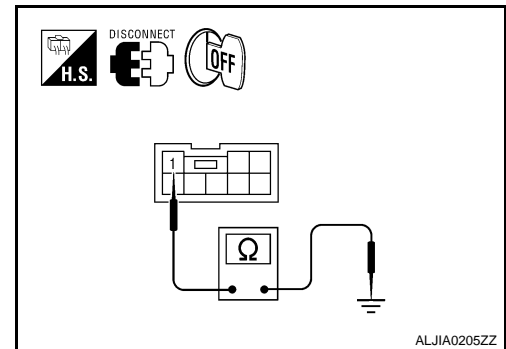

#### 3. CHECK A/T DEVICE HARNESS

- Check continuity between pedal adjusting control unit connector M14 (A) terminal 3 and A/T device connector M68 (B) terminal 8.

**3 - 8 : Continuity should exist.**

- Check continuity between pedal adjusting control unit connector M14 (A) terminal 3 and ground.

**3 - Ground : Continuity should not exist.**

Is the inspection result normal?

- YES >> GO TO 4
- NO >> Repair or replace harness.

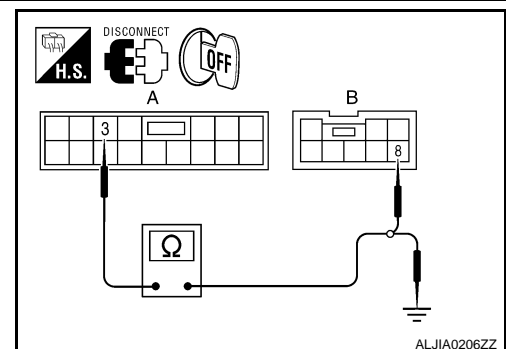

# ADJUSTABLE PEDAL SYSTEM

## < COMPONENT DIAGNOSIS >

### 4. CHECK A/T DEVICE

Check continuity between A/T device terminals as follows.

Terminals		Condition	Continuity
1	8	P position	Yes
		Other than P position	No

Is the inspection result normal?

YES >> Inspect shift lock system. Refer to [TM-217, "Checking of A/T Position"](#).

NO >> Replace column shift control device. Refer to [TM-215, "Control Device Removal and Installation"](#).

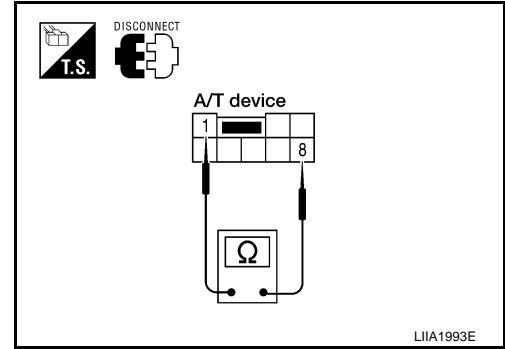

### Pedal Adjusting Switch Power Supply and Ground Circuit Inspection (Floor Shift)

INFOID:000000001665446

#### 1. CHECK PEDAL ADJUSTING SWITCH POWER SUPPLY

1. Turn ignition switch OFF, leave key in ignition cylinder.
2. Disconnect pedal adjusting switch.
3. Check voltage between pedal adjusting switch connector M96 terminal 1 and ground.

Connector	Terminals		Condition	Voltage (V) (Approx.)
	(+)	(-)		
M96	1	Ground	P position	Battery voltage
			Other than P position	0

Is the inspection result normal?

YES >> GO TO 3

NO >> GO TO 2

#### 2. CHECK PEDAL ADJUSTING SWITCH HARNESS

1. Disconnect pedal adjusting control unit.
2. Check continuity between pedal adjusting control unit connector M14 terminal 7 and pedal adjusting switch connector M96 terminal 1.

**7 - 1 : Continuity should exist.**

3. Check continuity between pedal adjusting control unit connector M14 terminal 7 and ground.

**7 - Ground : Continuity should not exist.**

Is the inspection result normal?

YES >> Check the condition of the harness and connector.

NO >> Repair or replace harness.

#### 3. CHECK PEDAL ADJUSTING SWITCH GROUND CIRCUIT

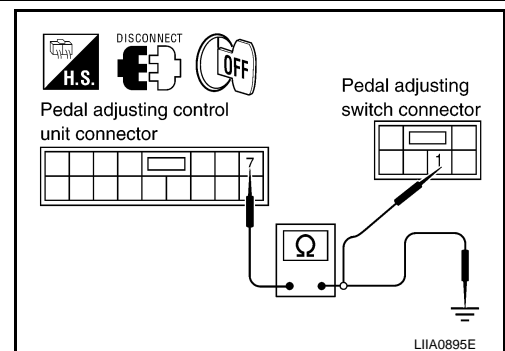
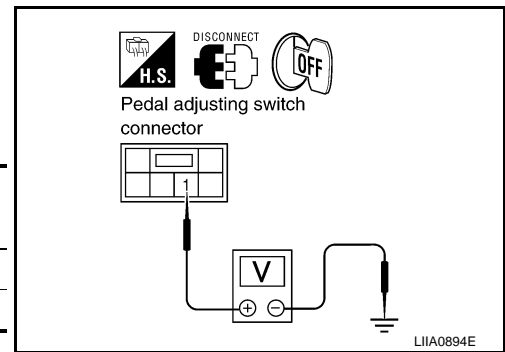

# ADJUSTABLE PEDAL SYSTEM

## < COMPONENT DIAGNOSIS >

Check continuity between pedal adjusting switch connector M96 terminal 4 and ground.

**4 - Ground : Continuity should exist.**

Is the inspection result normal?

- YES >> Replace pedal adjusting switch.
- NO >> Repair or replace harness.

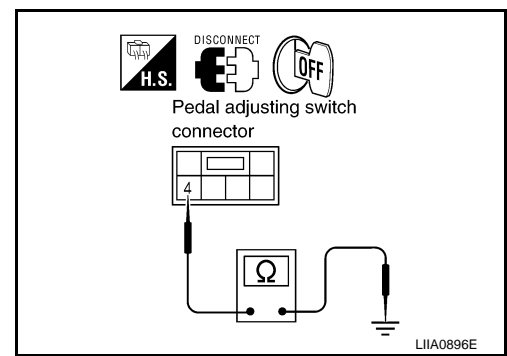

## Pedal Adjusting Switch Power Supply and Ground Circuit Inspection (Column Shift)

INFOID:000000001666591

### 1. CHECK PEDAL ADJUSTING SWITCH POWER SUPPLY

1. Turn ignition switch OFF.
2. Disconnect pedal adjusting switch.
3. Check voltage between pedal adjusting switch connector M96 terminal 1 and ground.

**1 - Ground : Battery voltage**

Is the inspection result normal?

- YES >> GO TO 3
- NO >> GO TO 2

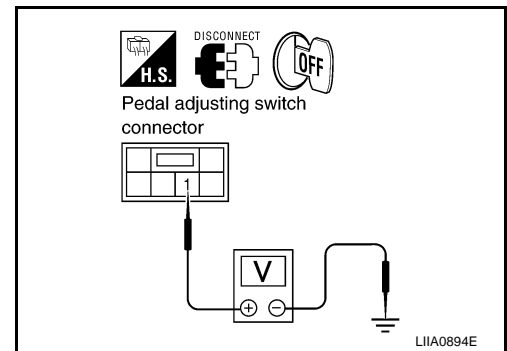

### 2. CHECK PEDAL ADJUSTING SWITCH HARNESS

1. Disconnect pedal adjusting control unit.
2. Check continuity between pedal adjusting control unit connector M14 terminal 7 and pedal adjusting switch connector M96 terminal 1.

**7 - 1 : Continuity should exist.**

3. Check continuity between pedal adjusting control unit connector M14 terminal 7 and ground.

**7 - Ground : Continuity should not exist.**

Is the inspection result normal?

- YES >> Check the condition of the harness and connector.
- NO >> Repair or replace harness.

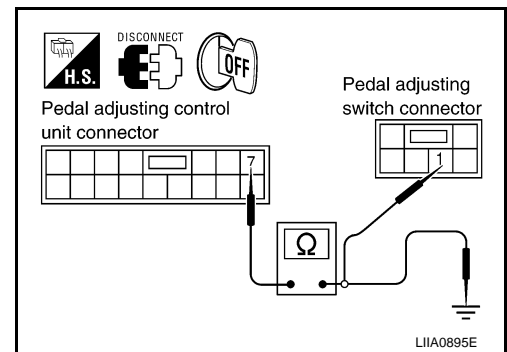

### 3. CHECK PEDAL ADJUSTING SWITCH GROUND CIRCUIT

Check continuity between pedal adjusting switch connector M96 terminal 4 and ground.

**4 - Ground : Continuity should exist.**

Is the inspection result normal?

- YES >> Replace pedal adjusting switch.
- NO >> Repair or replace harness.

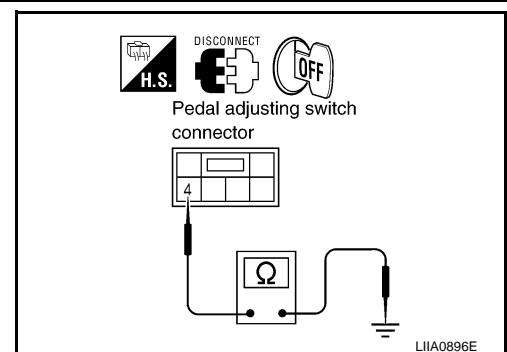

# ADJUSTABLE PEDAL SYSTEM

## < COMPONENT DIAGNOSIS >

### Pedal Adjusting Motor Circuit Inspection

INFOID:000000001665447

#### 1. CHECK PEDAL ADJUSTING SWITCH

1. Turn ignition switch OFF.
2. Disconnect pedal adjusting switch.
3. Check continuity between pedal adjusting switch terminals as follows.

Terminals	Condition	Continuity	
3	1	Pedal adjusting switch forward.	Continuity should exist.
		Pedal adjusting switch neutral.	Continuity should not exist.
	4	Pedal adjusting switch backward.	Continuity should exist.
		Pedal adjusting switch neutral.	Continuity should not exist.
2	1	Pedal adjusting switch backward.	Continuity should exist.
		Pedal adjusting switch neutral.	Continuity should not exist.
	4	Pedal adjusting switch forward.	Continuity should exist.
		Pedal adjusting switch neutral.	Continuity should not exist.

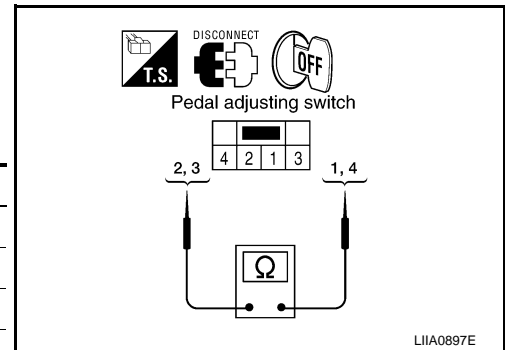

LIA0897E

Is inspection result normal?

YES >> GO TO 2

NO >> Replace pedal adjusting switch.

#### 2. CHECK PEDAL ADJUSTING MOTOR HARNESS

1. Disconnect pedal adjusting motor.
2. Check continuity between pedal adjusting switch connector M96 (A) terminals 2, 3 and pedal adjusting motor connector E109 (B) terminals 1, 2.

**2 - 2 : Continuity should exist.**

**3 - 1 : Continuity should exist.**

3. Check continuity between pedal adjusting switch connector M96 (A) terminals 2, 3 and ground.

**2 - Ground : Continuity should not exist.**

**3 - Ground : Continuity should not exist.**

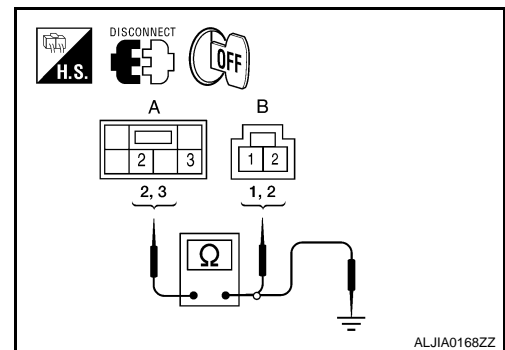

ALJIA0168ZZ

Is inspection result normal?

YES >> GO TO 3

NO >> Repair or replace harness.

#### 3. CHECK PEDAL ADJUSTING MOTOR POWER SUPPLY

1. Connect pedal adjusting switch.
2. Check voltage between pedal adjusting motor connector E109 and ground.

Connector	Terminals		Condition	Voltage (V) (Approx.)
	(+)	(-)		
E109	1	Ground	Pedal adjusting switch forward	Battery voltage
			Other than above	0
	2		Pedal adjusting switch backward	Battery voltage
			Other than above	0

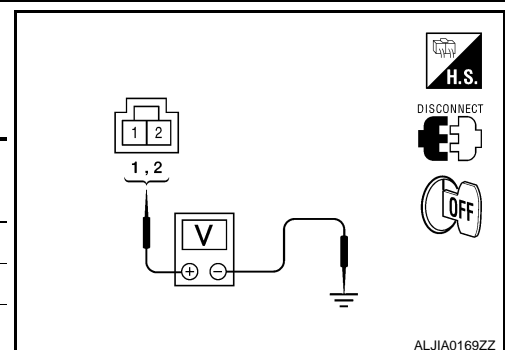

ALJIA0169ZZ

Is inspection result normal?

# ADJUSTABLE PEDAL SYSTEM

## < COMPONENT DIAGNOSIS >

---

YES >> Replace pedal adjusting motor.  
NO >> Repair or replace harness.

A

B

C

D

E

F

G

H

I

AP

K

L

M

N

O

P

# ADJUSTABLE PEDAL SYSTEM

< ECU DIAGNOSIS >

## ECU DIAGNOSIS

### ADJUSTABLE PEDAL SYSTEM

Reference Value

INFOID:000000001665448

#### TERMINAL LAYOUT

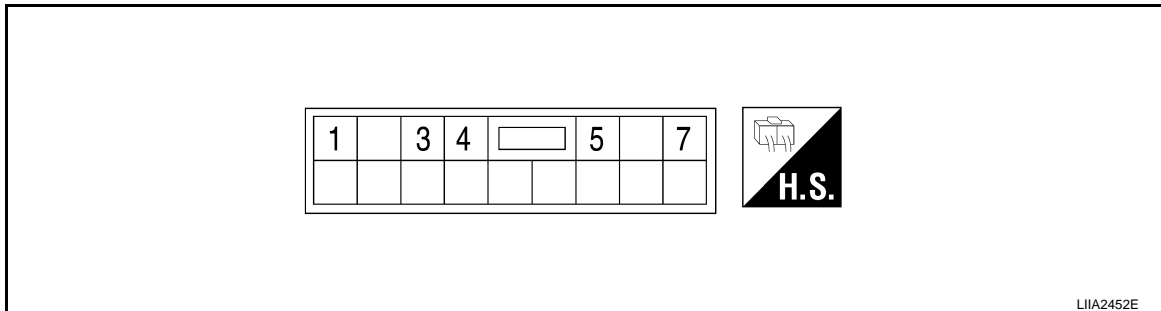

#### PHYSICAL VALUES

TERMI-NAL	WIRE COLOR	ITEM	CONDITION	VOLTAGE (V) (Approx.)
1	B	Ground	—	0
3	L/R	A/T device (park position switch) signal	A/T selector lever in other than P position	0
			A/T selector lever in P position	Battery voltage
4	G/R	Ignition switch (ON or START)	Ignition switch (ON or START position)	Battery voltage
5	L/B	Battery power supply	—	Battery voltage
7	W/R	Pedal adjusting switch power supply output	Ignition switch ON A/T selector lever in other than P position	0
			Ignition switch ON A/T selector lever in P position	Battery voltage



# ADJUSTABLE PEDAL SYSTEM

< ECU DIAGNOSIS >

## ADJUSTABLE PEDAL SYSTEM CONNECTORS

Connector No.	M6
Connector Name	WIRE TO WIRE
Connector Color	WHITE

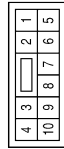

Terminal No.	Color of Wire	Signal Name
5	V	-
7	SB	-

Connector No.	M14
Connector Name	PEDAL ADJUSTING CONTROL UNIT
Connector Color	WHITE

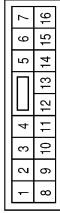

Terminal No.	Color of Wire	Signal Name
1	B	GROUND
3	L/R	DETENT (KEY) SW
4	G/R	IGN_SW
5	L/B	BAT (PTC)
7	W/R	PEDAL_MOTOR_ OUTPUT

Connector No.	M27
Connector Name	KEY SWITCH AND KEY LOCK SOLENOID
Connector Color	WHITE

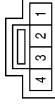

Terminal No.	Color of Wire	Signal Name
3	Y/R	-
4	B/R	-

Connector No.	M31
Connector Name	WIRE TO WIRE
Connector Color	WHITE

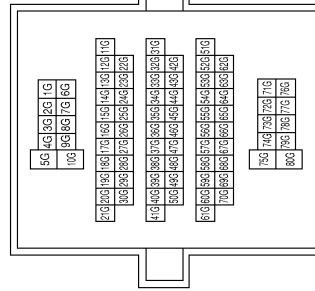

Terminal No.	Color of Wire	Signal Name
10G	W/B	-

Connector No.	M39
Connector Name	FUSE BLOCK (J/B)
Connector Color	WHITE



Terminal No.	Color of Wire	Signal Name
1Q	G/R	-
4Q	Y/R	-

Connector No.	M56
Connector Name	WIRE TO WIRE
Connector Color	WHITE



Terminal No.	Color of Wire	Signal Name
10	L/R	-
11	B/R	-

ALJIA0182GB



# ADJUSTABLE PEDAL SYSTEM

< ECU DIAGNOSIS >

Connector No.	M96
Connector Name	PEDAL ADJUSTING SWITCH
Connector Color	BROWN



Terminal No.	Color of Wire	Signal Name
1	W/R	-
2	SB	-
3	V	-
4	B	-

Connector No.	M82
Connector Name	CIRCUIT BREAKER-2
Connector Color	GRAY



Terminal No.	Color of Wire	Signal Name
1	L/B	-
2	W/B	-

Connector No.	M68
Connector Name	A/T DEVICE (COLUMN SHIFT)
Connector Color	WHITE

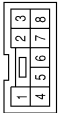

Terminal No.	Color of Wire	Signal Name
1	B	-
8	L/R	-

Connector No.	E10
Connector Name	WIRE TO WIRE
Connector Color	WHITE

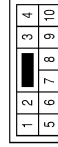

Terminal No.	Color of Wire	Signal Name
5	G	-
7	R	-

Connector No.	M203
Connector Name	A/T DEVICE (FLOOR SHIFT)
Connector Color	WHITE



Terminal No.	Color of Wire	Signal Name
5	B/R	-
6	L/R	-

Connector No.	M201
Connector Name	WIRE TO WIRE
Connector Color	WHITE



Terminal No.	Color of Wire	Signal Name
10	L/R	-
11	B/R	-

ALJIA0183GB

A  
B  
C  
D  
E  
F  
G  
H  
I  
AP  
K  
L  
M  
N  
O  
P

# ADJUSTABLE PEDAL SYSTEM

< ECU DIAGNOSIS >

Connector No.	E152
Connector Name	WIRE TO WIRE
Connector Color	WHITE

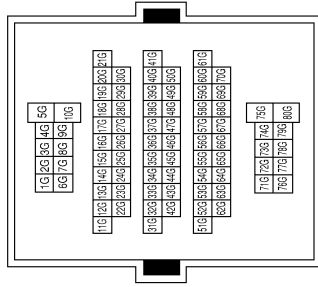

Terminal No.	Color of Wire	Signal Name
10G	W/B	-

Connector No.	E109
Connector Name	PEDAL ADJUSTING MOTOR
Connector Color	GRAY



Terminal No.	Color of Wire	Signal Name
1	G	-
2	R	-

ALJIA0203GB

# ADJUSTABLE PEDAL SYSTEM

< SYMPTOM DIAGNOSIS >

## SYMPTOM DIAGNOSIS

### ADJUSTABLE PEDAL SYSTEM

#### Symptom Table

INFOID:000000001665450

**NOTE:**

Always check the WORK FLOW before troubleshooting. Refer to [AP-2, "Repair Work Flow"](#).

Symptom	Diagnosis/Service procedure	Reference page
Adjustable pedal system does not operate.	1. Pedal adjusting control unit power supply and ground circuit inspection.	<a href="#">AP-7</a>
	2. Pedal adjusting switch power supply and ground circuit inspection (floor shift).	<a href="#">AP-10</a>
	3. Pedal adjusting switch power supply and ground circuit inspection (column shift).	<a href="#">AP-11</a>
	4. Pedal adjusting motor circuit inspection.	<a href="#">AP-12</a>
Adjustable pedal system does operate when ignition switch is turned ON and A/T selector lever is in other than P position.	1. A/T device (park position switch) circuit inspection (floor shift).	<a href="#">AP-8</a>
	2. A/T device (park position switch) circuit inspection (column shift).	<a href="#">AP-9</a>
	3. Pedal adjusting control unit ignition signal inspection.	<a href="#">AP-7</a>
	4. Replace pedal adjusting control unit.	—
Adjustable pedal system does not operate when ignition switch is turned ON and A/T selector lever is in P position.	1. A/T device (park position switch) circuit inspection (floor shift).	<a href="#">AP-8</a>
	1. A/T device (park position switch) circuit inspection (column shift).	<a href="#">AP-9</a>

A  
B  
C  
D  
E  
F  
G  
H  
I  
K  
L  
M  
N  
O  
P

AP

# PRECAUTIONS

< PRECAUTION >

## PRECAUTION

### PRECAUTIONS

#### Precaution for Supplemental Restraint System (SRS) "AIR BAG" and "SEAT BELT PRE-TENSIONER"

INFOID:000000001665451

The Supplemental Restraint System such as "AIR BAG" and "SEAT BELT PRE-TENSIONER", used along with a front seat belt, helps to reduce the risk or severity of injury to the driver and front passenger for certain types of collision. This system includes seat belt switch inputs and dual stage front air bag modules. The SRS system uses the seat belt switches to determine the front air bag deployment, and may only deploy one front air bag, depending on the severity of a collision and whether the front occupants are belted or unbelted. Information necessary to service the system safely is included in the SR and SB section of this Service Manual.

#### **WARNING:**

- **To avoid rendering the SRS inoperative, which could increase the risk of personal injury or death in the event of a collision which would result in air bag inflation, all maintenance must be performed by an authorized NISSAN/INFINITI dealer.**
- **Improper maintenance, including incorrect removal and installation of the SRS, can lead to personal injury caused by unintentional activation of the system. For removal of Spiral Cable and Air Bag Module, see the SR section.**
- **Do not use electrical test equipment on any circuit related to the SRS unless instructed to in this Service Manual. SRS wiring harnesses can be identified by yellow and/or orange harnesses or harness connectors.**

#### Precaution for Work

INFOID:000000001665452

- When removing or disassembling each component, be careful not to damage or deform it. If a component may be subject to interference, be sure to protect it with a shop cloth.
- When removing (disengaging) components with a screwdriver or similar tool, be sure to wrap the component with a shop cloth or vinyl tape to protect it.
- Protect the removed parts with a shop cloth and keep them.
- Replace a deformed or damaged clip.
- If a part is specified as a non-reusable part, always replace it with new one.
- Be sure to tighten bolts and nuts securely to the specified torque.
- After re-installation is completed, be sure to check that each part works normally.
- Follow the steps below to clean components.
  - Water soluble foul: Dip a soft cloth into lukewarm water, and wring the water out of the cloth to wipe the fouled area.  
Then rub with a soft and dry cloth.
  - Oily foul: Dip a soft cloth into lukewarm water with mild detergent (concentration: within 2 to 3%), and wipe the fouled area.  
Then dip a cloth into fresh water, and wring the water out of the cloth to wipe the detergent off. Then rub with a soft and dry cloth.
- Do not use organic solvent such as thinner, benzene, alcohol, or gasoline.
- For genuine leather seats, use a genuine leather seat cleaner.

# ADJUSTABLE PEDAL SYSTEM

< ON-VEHICLE REPAIR >

## ON-VEHICLE REPAIR

### ADJUSTABLE PEDAL SYSTEM

#### Removal and Installation

INFOID:000000001665453

Refer to [BR-19, "Removal and Installation"](#) and [ACC-3, "Removal and Installation"](#).

A  
B  
C  
D  
E  
F  
G  
H  
I  
K  
L  
M  
N  
O  
P

AP