

SECTION **CHG**
CHARGING SYSTEM

A
B
C
D
E
F
G
H
I
J
K
L
N
O
P

CONTENTS

PRECAUTION	2	Inspection Procedure	9
PRECAUTIONS	2	POWER GENERATION VOLTAGE VARIABLE CONTROL SYSTEM OPERATION INSPECTION	10
Precaution for Supplemental Restraint System (SRS) "AIR BAG" and "SEAT BELT PRE-TENSIONER"	2	Inspection Procedure	10
Precaution for Power Generation Variable Voltage Control System	2	B TERMINAL CIRCUIT	12
PREPARATION	3	Description	12
PREPARATION	3	Diagnosis Procedure	12
Special Service Tool	3	L TERMINAL CIRCUIT	13
Commercial Service Tool	3	Description	13
BASIC INSPECTION	4	Diagnosis Procedure	13
DIAGNOSIS AND REPAIR WORKFLOW	4	S TERMINAL CIRCUIT	14
Work Flow	4	Description	14
FUNCTION DIAGNOSIS	7	Diagnosis Procedure	14
CHARGING SYSTEM	7	CHARGING SYSTEM	15
System Diagram	7	Wiring Diagram	15
System Description	7	SYMPTOM DIAGNOSIS	20
Component Description	7	CHARGING SYSTEM	20
POWER GENERATION VOLTAGE VARIABLE CONTROL SYSTEM	8	Symptom Table	20
System Diagram	8	ON-VEHICLE REPAIR	21
System Description	8	GENERATOR	21
Component Description	8	Removal and Installation	21
COMPONENT DIAGNOSIS	9	SERVICE DATA AND SPECIFICATIONS (SDS)	22
CHARGING SYSTEM PRELIMINARY INSPECTION	9	GENERATOR	22
		Generator	22

CHG

PRECAUTIONS

< PRECAUTION >

PRECAUTION

PRECAUTIONS

Precaution for Supplemental Restraint System (SRS) "AIR BAG" and "SEAT BELT PRE-TENSIONER"

INFOID:000000001470301

The Supplemental Restraint System such as "AIR BAG" and "SEAT BELT PRE-TENSIONER", used along with a front seat belt, helps to reduce the risk or severity of injury to the driver and front passenger for certain types of collision. This system includes seat belt switch inputs and dual stage front air bag modules. The SRS system uses the seat belt switches to determine the front air bag deployment, and may only deploy one front air bag, depending on the severity of a collision and whether the front occupants are belted or unbelted. Information necessary to service the system safely is included in the SR and SB section of this Service Manual.

WARNING:

- To avoid rendering the SRS inoperative, which could increase the risk of personal injury or death in the event of a collision which would result in air bag inflation, all maintenance must be performed by an authorized NISSAN/INFINITI dealer.
- Improper maintenance, including incorrect removal and installation of the SRS, can lead to personal injury caused by unintentional activation of the system. For removal of Spiral Cable and Air Bag Module, see the SR section.
- Do not use electrical test equipment on any circuit related to the SRS unless instructed to in this Service Manual. SRS wiring harnesses can be identified by yellow and/or orange harnesses or harness connectors.

Precaution for Power Generation Variable Voltage Control System

INFOID:000000001470302

CAUTION:

For this model, the battery current sensor that is installed to the negative battery cable measures the charging/discharging current of the battery and performs various engine controls. If an electrical component is connected directly to the negative battery terminal, the current flowing through that component will not be measured by the battery current sensor. This condition may cause a malfunction of the engine control system and battery discharge may occur. Do not connect an electrical component or ground wire directly to the battery terminal.

PREPARATION

< PREPARATION >

PREPARATION

PREPARATION

Special Service Tool

INFOID:000000001470303

The actual shapes of Kent-Moore tools may differ from those of special service tools illustrated here.

Tool number (Kent-Moore No.) Tool name	Description
— (J-48087) Battery Service Center	Tests battery. For operating instructions, refer to Technical Service Bulletin and Battery Service Center User Guide.
— (J-44373) Model 620 Starting/Charging system tester	Tests starting and charging systems. For operating instructions, refer to Technical Service Bulletin.

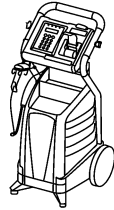

WKIA5280E

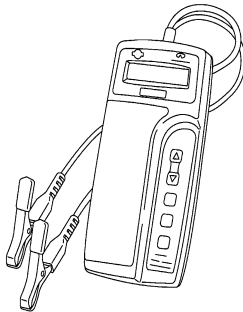

SEL403X

Commercial Service Tool

INFOID:000000001470304

Tool name	Description
Power tool	Loosening bolts and nuts

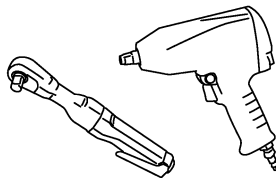

PBIC0190E

A
B
C
D
E
F
G
H
I
J
K
L
N
O
P

CHG

DIAGNOSIS AND REPAIR WORKFLOW

< BASIC INSPECTION >

BASIC INSPECTION

DIAGNOSIS AND REPAIR WORKFLOW

Work Flow

INFOID:000000001621539

OVERALL SEQUENCE

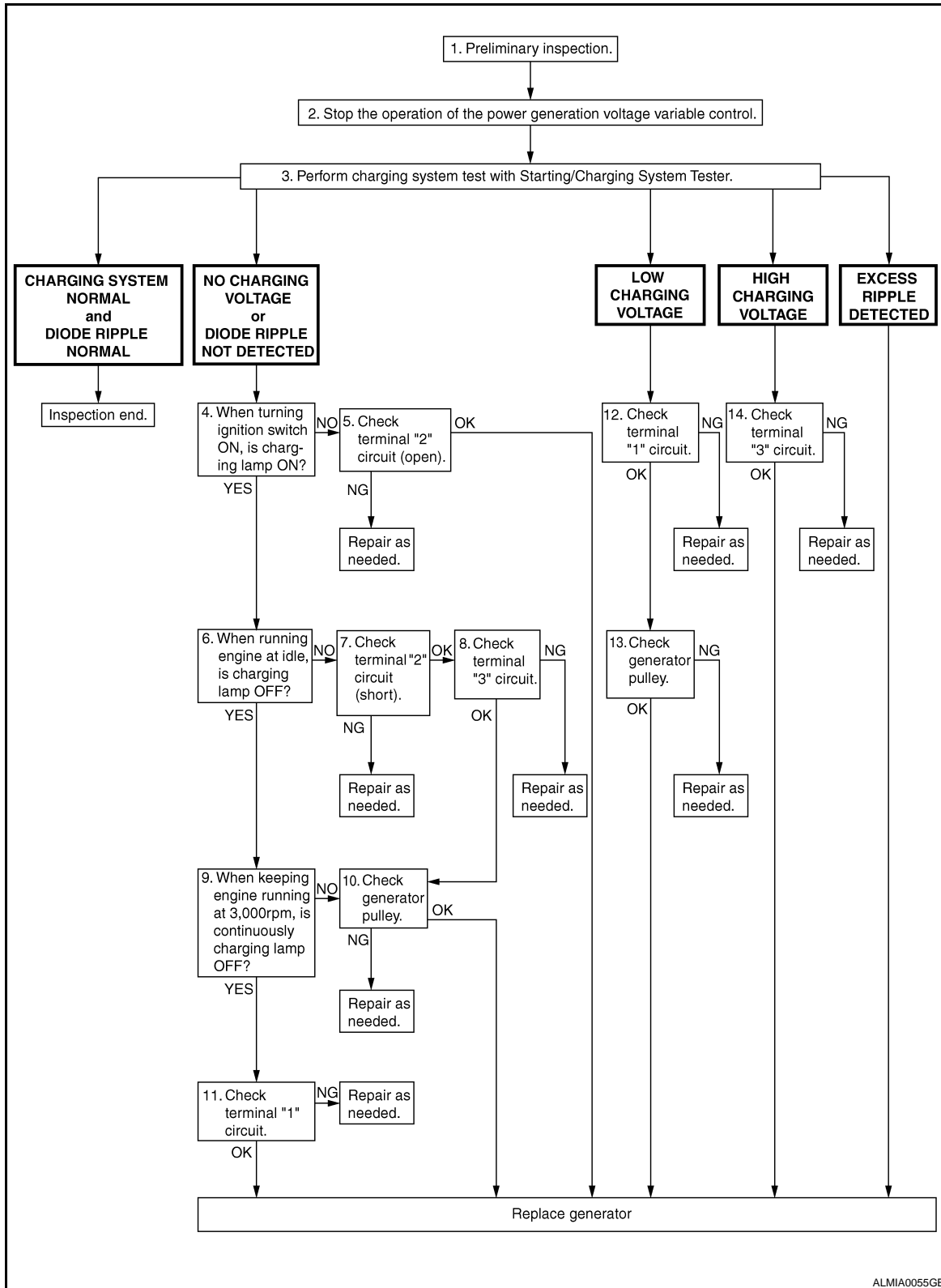

ALMIA0055GB

DETAILED FLOW

CHG-4

DIAGNOSIS AND REPAIR WORKFLOW

< BASIC INSPECTION >

NOTE:

To ensure a complete and thorough diagnosis, the battery, starter and generator test segments must be done as a set from start to finish.

1. PRELIMINARY INSPECTION

Perform the preliminary inspection. Refer to [CHG-9, "Inspection Procedure"](#).

>> GO TO 2.

2. DISABLE THE POWER GENERATION VOLTAGE VARIABLE CONTROL SYSTEM

Disable the power generation voltage variable control with either of the following procedures.

- After selecting "ENGINE" on the "SELECT SYSTEM" screen of CONSULT-III, set the "ALTERNATOR DUTY" value to 0 % by selecting "ALTERNATOR DUTY" with "Active Test". Continue "Active Test" until the end of inspection. (When the DUTY value is 0 or 100 %, the normal power generation is performed according to the characteristic of the IC regulator of the generator.)
- Turn the ignition switch OFF, disconnect the battery current sensor connector and leave it disconnected during the course of the test.

NOTE:

Running the engine with the battery current sensor disconnected will cause DTC's (P1550-P1554) to set. After finishing the inspection, connect the battery current sensor connector and erase the self-diagnostic results history of the engine using CONSULT-III.

>> GO TO 3.

3. DIAGNOSIS WITH STARTING/CHARGING SYSTEM TESTER

Perform the charging system test using Starting/Charging System Tester (J-44373). For details and operating instructions, refer to Technical Service Bulletin.

Test result

- CHARGING SYSTEM NORMAL>>Charging system is normal and will also show "DIODE RIPPLE" test result.
NO CHARGING VOLTAGE>>GO TO 4.
LOW CHARGING VOLTAGE>>GO TO 12.
HIGH CHARGING VOLTAGE>>GO TO 14.
DIODE RIPPLE NORMAL>>Diode ripple is OK and will also show "CHARGING VOLTAGE" test result.
EXCESS RIPPLE DETECTED>>Replace the generator. Perform "DIODE RIPPLE" test again using Starting/Charging System Tester (J-44373) to confirm repair.
DIODE RIPPLE NOT DETECTED>>GO TO 4.

4. INSPECTION WITH CHARGE WARNING LAMP (IGNITION SWITCH IS ON)

Turn the ignition switch ON.

Does the charge warning lamp illuminate?

- YES >> GO TO 6.
NO >> GO TO 5.

5. TERMINAL "2" (OPEN) CIRCUIT INSPECTION

Check terminal "2" circuit for open circuits. Refer to [CHG-13, "Diagnosis Procedure"](#).

Is the terminal "2" circuit normal?

- YES >> Replace generator.
NO >> Repair as needed.

6. INSPECTION WITH CHARGE WARNING LAMP (IDLING)

Start the engine and run it at idle.

Does the charge warning lamp turn OFF?

- YES >> GO TO 9.
NO >> GO TO 7.

7. TERMINAL "2"(SHORT) CIRCUIT INSPECTION

Check terminal "2" circuit for short to ground. Refer to [CHG-13, "Diagnosis Procedure"](#).

Is the terminal "2" circuit normal?

DIAGNOSIS AND REPAIR WORKFLOW

< BASIC INSPECTION >

- YES >> GO TO 8.
- NO >> Repair as needed.

8. TERMINAL "3" CIRCUIT INSPECTION

Check terminal "3" circuit. Refer to [CHG-14, "Diagnosis Procedure"](#).

Is the terminal "3" circuit normal?

- YES >> GO TO 10.
- NO >> Repair as needed.

9. INSPECTION WITH CHARGE WARNING LAMP (ENGINE AT 3,000 RPM)

Increase and maintain the engine speed at 3,000 rpm.

Does the charge warning lamp remain off?

- YES >> GO TO 11.
- NO >> GO TO 10.

10. INSPECTION OF GENERATOR PULLEY

Check generator pulley.

Is generator pulley normal?

- YES >> Replace generator. Refer to [CHG-21, "Removal and Installation"](#).
- NO >> Repair as needed.

11. TERMINAL "1" CIRCUIT INSPECTION

Check terminal "1" circuit. Refer to [CHG-12, "Diagnosis Procedure"](#).

Is terminal "1" circuit normal?

- YES >> Replace generator. Refer to [CHG-21, "Removal and Installation"](#).
- NO >> Repair as needed.

12. TERMINAL "1" CIRCUIT INSPECTION

Check terminal "1" circuit. Refer to [CHG-12, "Diagnosis Procedure"](#).

Is terminal "1" circuit normal?

- YES >> GO TO 13.
- NO >> Repair as needed.

13. INSPECTION OF GENERATOR PULLEY

Check generator pulley.

Is generator pulley normal?

- YES >> Replace generator. Refer to [CHG-21, "Removal and Installation"](#).
- NO >> Repair as needed.

14. TERMINAL "3" CIRCUIT INSPECTION

Check terminal "3" circuit. Refer to [CHG-14, "Diagnosis Procedure"](#).

Is the terminal "3" circuit normal?

- YES >> Replace generator. Refer to [CHG-21, "Removal and Installation"](#).
- NO >> Repair as needed.

CHARGING SYSTEM

< FUNCTION DIAGNOSIS >

FUNCTION DIAGNOSIS

CHARGING SYSTEM

System Diagram

INFOID:000000001621540

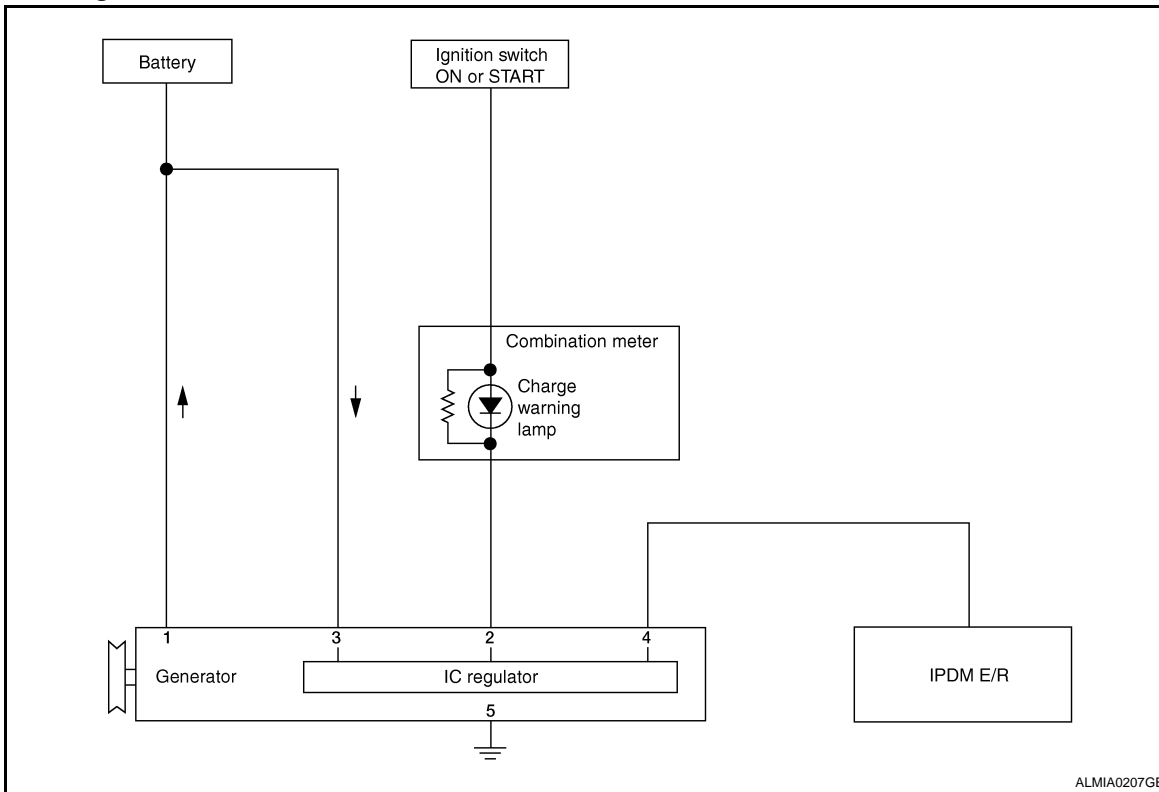

ALMIA0207GB

System Description

INFOID:000000001621541

The generator provides DC voltage to operate the vehicle's electrical system and to keep the battery charged. The voltage output is controlled by the IC regulator.

Component Description

INFOID:000000001621542

Component part		Description
Generator	Terminal "1"	Refer to CHG-12, "Description" .
	Terminal "2"	Refer to CHG-14, "Description" .
	Terminal "3"	Refer to CHG-13, "Description" .
	Terminal "4"	Used for the power generation voltage variable control system. Refer to CHG-8, "System Description" .
Combination meter (Charge warning lamp)		The IC regulator warning function activates to illuminate the charge warning lamp if any of the following symptoms occur while generator is operating: <ul style="list-style-type: none"> Excessive voltage is produced. No voltage is produced.
IPDM E/R		Used for the power generation voltage variable control system. Refer to CHG-8, "System Description" .

A

B

C

D

E

F

G

H

I

J

K

L

CHG

N

O

P

POWER GENERATION VOLTAGE VARIABLE CONTROL SYSTEM

< FUNCTION DIAGNOSIS >

POWER GENERATION VOLTAGE VARIABLE CONTROL SYSTEM

System Diagram

INFOID:000000001621543

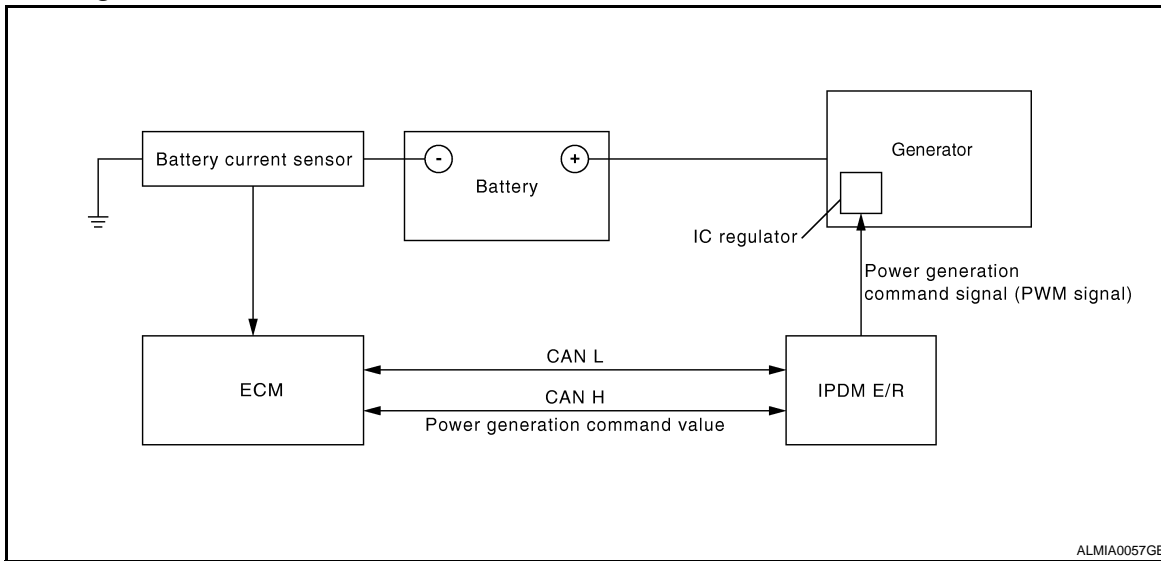

ALMIA0057GB

System Description

INFOID:000000001621544

Power generation variable voltage control system has been adopted. By varying the voltage to the generator, engine load due to power generation of the generator is reduced and fuel consumption is decreased.

NOTE:

When any malfunction is detected in the power generation variable voltage control system, power generation is performed according to the characteristic of the IC regulator in the generator.

Component Description

INFOID:000000001621545

Component part	Description
Battery current sensor	The battery current sensor is installed on the battery cable at the negative terminal. The battery current sensor detects the charging/discharging current of the battery and sends a voltage signal to the ECM according to the current value detected.
ECM	The battery current sensor detects the charging/discharging current of the battery. The ECM judges the battery condition based on this signal. The ECM judges whether to request more output via the power generation voltage variable control according to the battery condition. When performing the power generation voltage variable control, the ECM calculates the target power generation voltage according to the battery condition and sends the calculated value as the power generation command value to the IPDM E/R.
IPDM E/R	The IPDM E/R converts the received power generation command value into a pulse width modulated (PWM) command signal and sends it to the IC regulator.
Generator (IC regulator)	The IC regulator controls the power generation voltage by the target power generation voltage based on the received PWM command signal. When there is no PWM command signal, the generator performs the normal power generation according to the characteristic of the IC regulator.

CHARGING SYSTEM PRELIMINARY INSPECTION

< COMPONENT DIAGNOSIS >

COMPONENT DIAGNOSIS

CHARGING SYSTEM PRELIMINARY INSPECTION

Inspection Procedure

INFOID:000000001621546

1. CHECK BATTERY TERMINALS CONNECTION

Check if battery terminals are clean and tight.

Is the inspection result normal?

YES >> GO TO 2

NO >> Repair battery terminals connection.

2. CHECK FUSE

Check for blown fuse and fusible link.

Unit	Power source (Power supply terminals)	Fuse or Fusible Link
Generator	Battery (terminal 3)	Fuse 30
	Battery (terminal 1)	Fusible Link A
Combination meter	Ignition switch ON (terminal 2)	Fuse 14

Is the inspection result normal?

YES >> GO TO 3

NO >> Be sure to eliminate cause of malfunction before installing new fuse or fusible link.

3. CHECK GENERATOR GROUND TERMINAL CONNECTION

Verify connector E206 terminal 5 (generator ground harness) is clean and tight.

Is the inspection result normal?

YES >> GO TO 4

NO >> Repair connection.

4. CHECK DRIVE BELT TENSION

Check drive belt tension. Refer to [EM-12. "Checking Drive Belts"](#).

Is the inspection result normal?

YES >> Inspection end.

NO >> Repair as needed.

A
B
C
D
E
F
G
H
I
J
K
L
N
O
P

CHG

POWER GENERATION VOLTAGE VARIABLE CONTROL SYSTEM OPERATION INSPECTION

< COMPONENT DIAGNOSIS >

POWER GENERATION VOLTAGE VARIABLE CONTROL SYSTEM OPERATION INSPECTION

Inspection Procedure

INFOID:000000001621547

CAUTION:

When performing this inspection, always use a charged battery that has completed the battery inspection. (When the charging rate of the battery is low, the response speed of the voltage change will become slow. This can cause an incorrect inspection.)

1. CHECK ECM (CONSULT-III)

Perform ECM self-diagnosis with CONSULT-III. Refer to [EC-67. "CONSULT-III Function \(ENGINE\)".](#)

Self-diagnostic results content

No malfunction detected>> GO TO 2

Malfunction detected>> Check applicable parts, and repair or replace corresponding parts.

2. CHECK OPERATION OF POWER GENERATION VOLTAGE VARIABLE CONTROL SYSTEM

1. Connect CONSULT-III and start the engine.
2. The selector lever is in "P" or "N" position and all of the electric loads and A/C, etc. are turned OFF.
3. Select "ALTERNATOR DUTY" in "Active Test" of "ENGINE", and then check the value of "BATTERY VOLT" monitor when DUTY value of "ALTERNATOR DUTY" is set to 40.0 %.

"BATTERY VOLT"

2 seconds after setting the DUTY value of "ALTERNATOR DUTY" to 40.0 % : 12 - 13.6 V

4. Check the value of "BATTERY VOLT" monitor when DUTY value of "ALTERNATOR DUTY" is set to 80.0%.

"BATTERY VOLT"

20 seconds after setting the DUTY value of "ALTERNATOR DUTY" to 80.0 % : +0.5 V or more against the value of "BATTERY VOLT" monitor when DUTY value is 40.0 %

Is the measurement value within specification?

YES >> Inspection end.

NO >> GO TO 3

3. CHECK IPDM E/R (CONSULT-III)

Perform IPDM E/R self-diagnosis with CONSULT-III. Refer to [PCS-12. "CONSULT - III Function \(IPDM E/R\)".](#)

Self-diagnostic results content

No malfunction detected>> GO TO 4

Malfunction detected>> Check applicable parts, and repair or replace corresponding parts.

4. CHECK HARNESS BETWEEN GENERATOR AND IPDM E/R

1. Turn ignition switch OFF.
2. Disconnect generator connector E205 and IPDM E/R connector E122.
3. Check continuity between generator harness connector E205 (A) terminal 4 and IPDM E/R harness connector E122 (B) terminal 37.

A		B		Continuity
Connector	Terminal	Connector	Terminal	
E205	4	E122	37	Yes

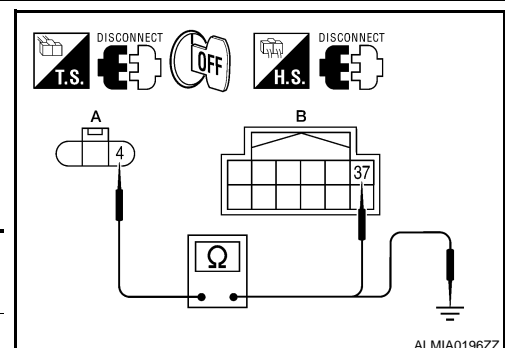

ALMIA0196ZZ

POWER GENERATION VOLTAGE VARIABLE CONTROL SYSTEM OPERATION INSPECTION

< COMPONENT DIAGNOSIS >

4. Check continuity between generator harness connector E122 (A) terminal 4 and ground.

A		—	Continuity
Connector	Terminal		
E205	4	Ground	No

Are the continuity test results as specified?

YES >> Replace IPDM E/R.

NO >> Repair harness or connector between IPDM E/R and generator.

A

B

C

D

E

F

G

H

I

J

K

L

CHG

N

O

P

B TERMINAL CIRCUIT

< COMPONENT DIAGNOSIS >

B TERMINAL CIRCUIT

Description

INFOID:000000001621548

The terminal "1" (B) circuit supplies power to charge the battery and operate the vehicles electrical system.

Diagnosis Procedure

INFOID:000000001621549

1.CHECK TERMINAL "1" CONNECTION

1. Turn ignition switch OFF.
2. Verify terminal "1" is clean and tight.

Is the inspection result normal?

YES >> GO TO 2

NO >> Repair terminal "1" connection. Confirm repair by performing complete Starting/Charging system test. Refer to Technical Service Bulletin.

2.CHECK TERMINAL "1" CIRCUIT

Check voltage between generator connector E204 terminal 1 and ground.

(+)		(-)	Voltage
Connector	Terminal		
E204	1	Ground	Battery voltage

Is voltage reading as specified?

YES >> GO TO 3.

NO >> Check harness for open between generator and fusible link.

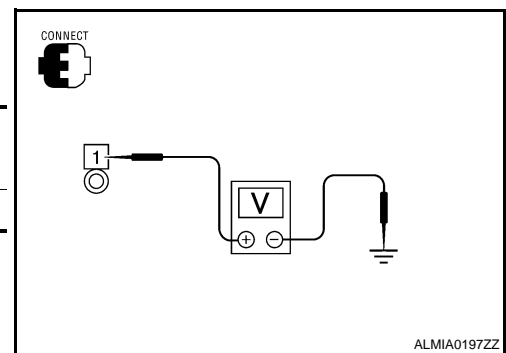

3.CHECK TERMINAL "1" CONNECTION (VOLTAGE DROP TEST)

1. Start engine, then engine running at idle and warm.
2. Check voltage between battery positive terminal and generator connector E204 terminal 1.

(+)		(-)	Voltage
Connector	Terminal		
E204	1	Battery positive terminal	Less than 0.2V

Is the voltage reading as specified?

YES >> Terminal "1" circuit is normal. Refer to [CHG-4, "Work Flow"](#).

NO >> Check harness between battery and generator for high resistance.

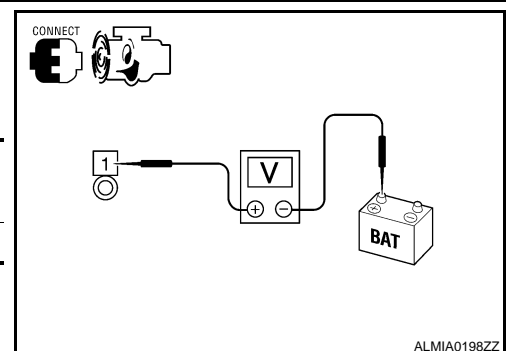

L TERMINAL CIRCUIT

< COMPONENT DIAGNOSIS >

L TERMINAL CIRCUIT

Description

INFOID:000000001621550

The terminal "2" (L) circuit controls the charge warning lamp. The charge warning lamp illuminates when the ignition switch is set to ON or START. When the generator is providing sufficient voltage with the engine running, the charge warning lamp will go off. If the charge warning lamp illuminates with the engine running, a malfunction is indicated.

Diagnosis Procedure

INFOID:000000001621551

1. CHECK CHARGE WARNING LAMP CIRCUIT CONNECTION

Verify generator connector E205 terminal 2 is clean and tight.

Is the connection secure?

YES >> GO TO 2

NO >> Repair the connection. Confirm repair by performing complete Starting/Charging system test. Refer to Technical Service Bulletin.

2. CHECK CHARGE WARNING LAMP CIRCUIT

1. Disconnect generator connector E205.
2. Apply ground to generator harness connector E205 terminal 2 with the ignition switch in the ON position.

Charge lamp should illuminate

Does the charge lamp illuminate?

YES >> Check generator function. Refer to [CHG-4, "Work Flow"](#).

NO >> GO TO 3

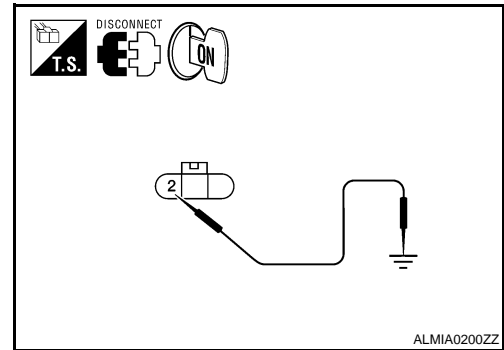

3. CHECK HARNESS CONTINUITY

1. Turn ignition switch OFF.
2. Disconnect the generator connector E205 and combination meter connector M23.
3. Check continuity between generator harness connector E205 (A) terminal 2 and combination meter harness connector M23 (B) terminal 45.

A		B		Continuity
Connector	Terminal	Connector	Terminal	
E205	2	M23	45	Yes

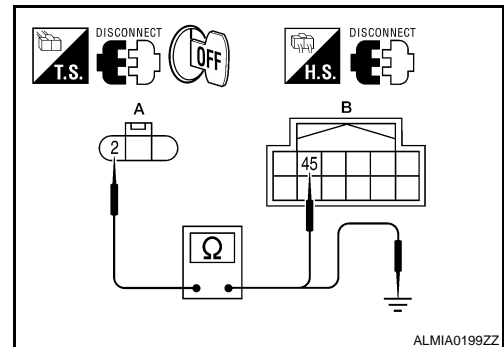

4. Check continuity between generator harness connector E205 (A) terminal 2 and ground.

A		—	Continuity
Connector	Terminal		
E205	2	Ground	No

Are the continuity results as specified?

YES >> Replace the combination meter. Refer to [MWI-72, "Removal and Installation"](#).

NO >> Repair the harness or connector.

A
B
C
D
E
F
G
H
I
J
K
L
N
O
P

CHG

S TERMINAL CIRCUIT

< COMPONENT DIAGNOSIS >

S TERMINAL CIRCUIT

Description

INFOID:000000001621552

The output voltage of the generator is controlled by the IC regulator at terminal "3" (S) detecting the input voltage. Terminal "3" circuit detects the battery voltage to adjust the generator output voltage with the IC regulator.

Diagnosis Procedure

INFOID:000000001621553

1. CHECK VOLTAGE REGULATOR CIRCUIT CONNECTION

Check to see if connector E205 terminal 3 is clean and tight.

Is the inspection result normal?

YES >> GO TO 2

NO >> Repair terminal connection. Confirm repair by performing complete Starting/Charging system test.
Refer to Technical Service Bulletin.

2. CHECK VOLTAGE REGULATOR CIRCUIT

Check voltage between generator harness connector E205 terminal 3 and ground.

3 - ground

Battery voltage

Does battery voltage exist?

YES >> Refer to [CHG-4. "Work Flow"](#).

NO >> Check harness for open between generator and fuse.

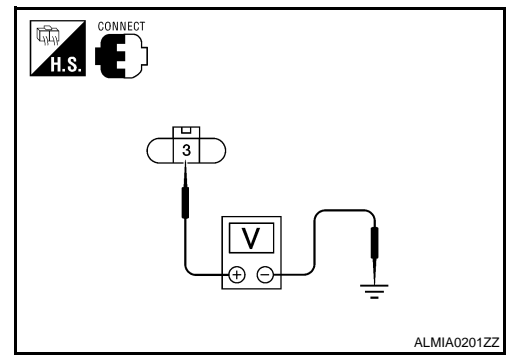

CHARGING SYSTEM

< COMPONENT DIAGNOSIS >

CHARGING SYSTEM

Wiring Diagram

INFOID:000000001621554

--- : DATA LINE

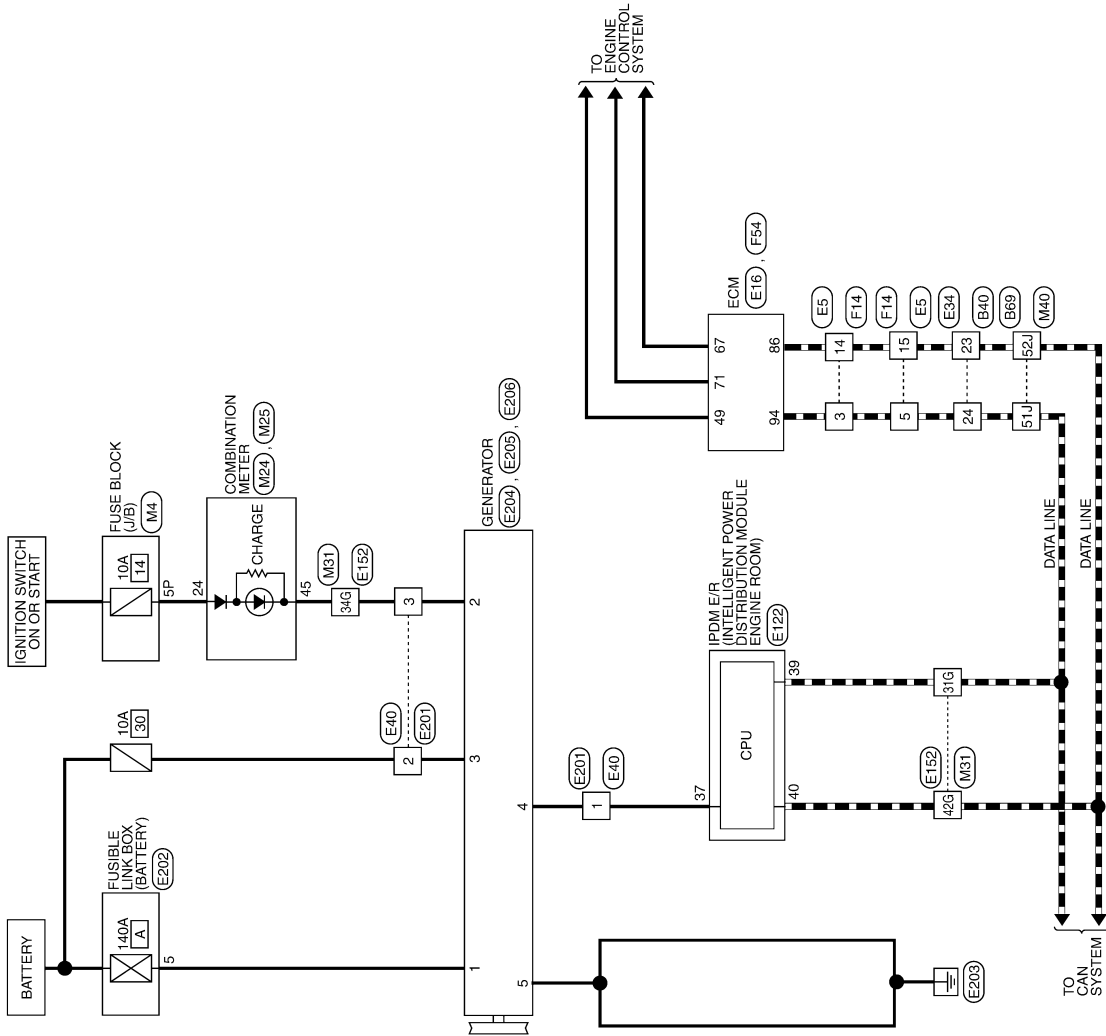

CHARGING SYSTEM

A
B
C
D
E
F
G
H
I
J
K
L
N
O
P

CHG

ALMWA0066GE

CHARGING SYSTEM

< COMPONENT DIAGNOSIS >

Connector No.	E50
Connector Name	WIRE TO WIRE
Connector Color	BROWN



Terminal No.	Color of Wire	Signal Name
1	P	-
2	L	-

Connector No.	E40
Connector Name	WIRE TO WIRE
Connector Color	BLACK



Terminal No.	Color of Wire	Signal Name
1	Y	-
2	Y/B	-
3	BR/W	-

Connector No.	E16
Connector Name	ECM
Connector Color	BLACK

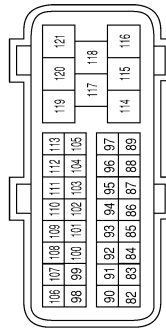

Terminal No.	Color of Wire	Signal Name
86	P	CAN-L
94	L	CAN-H

Connector No.	E201
Connector Name	WIRE TO WIRE
Connector Color	BLACK



Terminal No.	Color of Wire	Signal Name
1	Y	-
2	Y/B	-
3	BR/W	-

Connector No.	E152
Connector Name	WIRE TO WIRE
Connector Color	WHITE

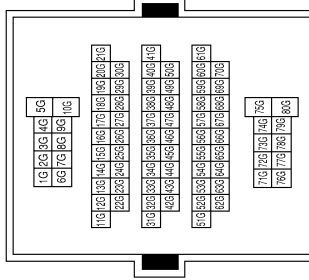

Terminal No.	Color of Wire	Signal Name
31G	L	-
34G	BR/W	-
42G	P	-

Connector No.	E122
Connector Name	IPDM E/R (INTELLIGENT POWER DISTRIBUTION MODULE ENGINE ROOM)
Connector Color	WHITE

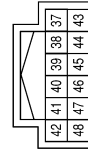

Terminal No.	Color of Wire	Signal Name
37	Y	ALT_C
39	L	CAN-H
40	P	CAN-L

AWMIA0027GB

A
B
C
D
E
F
G
H
I
J
K
L
N
O
P

CHG

CHARGING SYSTEM

< COMPONENT DIAGNOSIS >

Connector No.	E202
Connector Name	FUSIBLE LINK BOX (BATTERY)
Connector Color	BLACK



Terminal No.	Color of Wire	Signal Name
5	B/R	-

Connector No.	E204
Connector Name	GENERATOR
Connector Color	-



Terminal No.	Color of Wire	Signal Name
1	B/R	-

Connector No.	E205
Connector Name	GENERATOR
Connector Color	BLACK



Terminal No.	Color of Wire	Signal Name
2	BR/W	-
3	Y/B	-
4	Y	-

Connector No.	E206
Connector Name	GENERATOR
Connector Color	-



Terminal No.	Color of Wire	Signal Name
5	B	-

Connector No.	F14
Connector Name	WIRE TO WIRE
Connector Color	WHITE

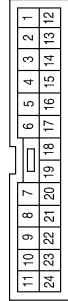

Terminal No.	Color of Wire	Signal Name
3	L	-
5	L	-
14	P	-
15	P	-

Connector No.	F54
Connector Name	ECM
Connector Color	BLACK

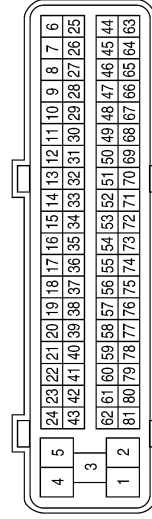

Terminal No.	Color of Wire	Signal Name
49	R/Y	AVCC (PDPRES)
67	B	GND-A
71	R	CURR_SENS

CHARGING SYSTEM

< COMPONENT DIAGNOSIS >

Connector No.	B75
Connector Name	WIRE TO WIRE
Connector Color	BROWN



Terminal No.	Color of Wire	Signal Name
1	P	-
2	L	-

Connector No.	B69
Connector Name	WIRE TO WIRE
Connector Color	WHITE

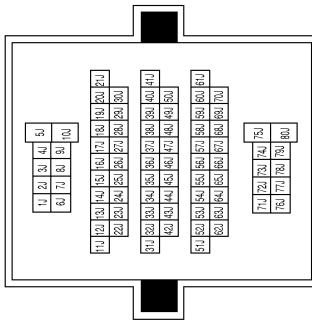

Terminal No.	Color of Wire	Signal Name
51J	L	-
52J	P	-

A
B
C
D
E
F
G
H
I
J
K
L
N
O
P

CHG

AWMIA0029GB

CHARGING SYSTEM

< SYMPTOM DIAGNOSIS >

SYMPTOM DIAGNOSIS

CHARGING SYSTEM

Symptom Table

INFOID:000000001621555

Symptom	Reference
Battery discharged	Refer to CHG-4, "Work Flow" .
The charge warning lamp does not illuminate when the ignition switch is set to ON.	
The charge warning lamp does not turn OFF after the engine starts.	
The charging warning lamp turns ON when increasing the engine speed.	

GENERATOR

< ON-VEHICLE REPAIR >

ON-VEHICLE REPAIR

GENERATOR

Removal and Installation

INFOID:000000001470305

REMOVAL

1. Disconnect the negative battery terminal.
2. Remove the fan shroud. Refer to [CO-15. "Removal and Installation"](#).
3. Remove the drive belt. Refer to [EM-12. "Removal and Installation"](#).
4. Remove lower bracket, using power tools.
5. Remove the generator upper bolt, using power tools.
6. Remove/disconnect the generator harness connectors.
7. Remove the generator.

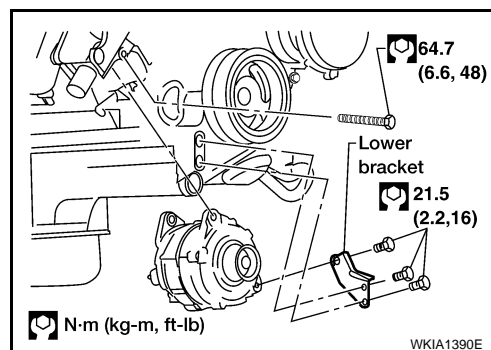

INSTALLATION

Installation is in the reverse order of removal.

- Install the generator and check the tension of the drive belt. Refer to [EM-12. "Checking Drive Belts"](#).

CAUTION:

Tighten terminal nut carefully.

Terminal nut : 10.8 N-m (1.1 kg-m, 8 ft-lb)

A
B
C
D
E
F
G
H
I
J
K
L
N
O
P

CHG

GENERATOR

< SERVICE DATA AND SPECIFICATIONS (SDS)

SERVICE DATA AND SPECIFICATIONS (SDS)

GENERATOR

Generator

INFOID:000000001470306

Type	LR1130-701
	Hitachi
Nominal rating	12V-130A
Ground polarity	Negative
Minimum revolution under no-load (When 13.5 volts is applied)	1,200 rpm
Hot output current (When 13.5 volts is applied)	More than 78A/1,800 rpm More than 108A/2,500 rpm More than 130A/5,000 rpm
Regulated output voltage	14.1 - 14.7V @ 25°C
Minimum length of brush	6 mm (0.24 in)
Brush spring pressure	1.0 - 3.432 N (0.102 - 0.3501 kg, 0.22 - 0.7715 lbs)
Slip ring minimum outer diameter	26 mm (1.02 in)
Rotor (Field coil) resistance	2.1 ohms