

SECTION **DLK**
DOOR & LOCK

A
B
C

CONTENTS

BASIC INSPECTION	4	COMMON ITEM : CONSULT-III Function (BCM - COMMON ITEM)	15	F
DIAGNOSIS AND REPAIR WORKFLOW	4	DOOR LOCK	15	G
Work Flow	4	DOOR LOCK : CONSULT-III Function (BCM - DOOR LOCK)	15	
INSPECTION AND ADJUSTMENT	7	REMOTE KEYLESS ENTRY	16	H
ADDITIONAL SERVICE WHEN REPLACING CONTROL UNIT	7	REMOTE KEYLESS ENTRY : CONSULT-III Function (BCM - RKE)	16	
ADDITIONAL SERVICE WHEN REPLACING CONTROL UNIT : Description	7	COMPONENT DIAGNOSIS	18	I
ADDITIONAL SERVICE WHEN REPLACING CONTROL UNIT : Special Repair Requirement	7	U1000 CAN COMM CIRCUIT	18	J
FUNCTION DIAGNOSIS	8	Description	18	
DOOR LOCK FUNCTION	8	DTC Logic	18	
DOOR LOCK AND UNLOCK SWITCH	8	Diagnosis Procedure	18	
DOOR LOCK AND UNLOCK SWITCH : System Diagram	8	U1010 CONTROL UNIT (CAN)	19	L
DOOR LOCK AND UNLOCK SWITCH : System Description	8	DTC Logic	19	
DOOR LOCK AND UNLOCK SWITCH : Component Parts Location	9	Diagnosis Procedure	19	
DOOR LOCK AND UNLOCK SWITCH : Component Description	9	Special Repair Requirement	19	
REMOTE KEYLESS ENTRY	10	POWER SUPPLY AND GROUND CIRCUIT	20	M
REMOTE KEYLESS ENTRY : System Diagram	10	BCM (BODY CONTROL MODULE)	20	
REMOTE KEYLESS ENTRY : System Description	10	BCM (BODY CONTROL MODULE) : Diagnosis Procedure	20	
REMOTE KEYLESS ENTRY : Component Parts Location	12	DOOR SWITCH	21	N
REMOTE KEYLESS ENTRY : Component Description	12	KING CAB	21	O
HOMELINK UNIVERSAL TRANSCEIVER	14	KING CAB : Description	21	
Component Description	14	KING CAB : Component Function Check	21	
DIAGNOSIS SYSTEM (BCM)	15	KING CAB : Diagnosis Procedure	21	
COMMON ITEM	15	CREW CAB	22	P
		CREW CAB : Description	22	
		CREW CAB : Component Function Check	22	
		CREW CAB : Diagnosis Procedure	23	
		DOOR LOCK AND UNLOCK SWITCH	25	
		KING CAB	25	

DLK

KING CAB : Description	25	WARNING CHIME FUNCTION	46
KING CAB : Component Function Check	25	Description	46
KING CAB : Diagnosis Procedure	25	Component Function Check	46
CREW CAB	27	Diagnosis Procedure	46
CREW CAB : Description	27	HAZARD FUNCTION	47
CREW CAB : Component Function Check	27	Description	47
CREW CAB : Diagnosis Procedure	27	Component Function Check	47
FRONT DOOR LOCK ASSEMBLY LH (KEY CYLINDER SWITCH)	30	Diagnosis Procedure	47
KING CAB	30	HEADLAMP FUNCTION	48
KING CAB : Description	30	Diagnosis Procedure	48
KING CAB : Component Function Check	30	MAP LAMP AND IGNITION KEYHOLE ILLU- MINATION FUNCTION	49
KING CAB : Diagnosis Procedure	30	Diagnosis Procedure	49
CREW CAB	31	KEYFOB ID SET UP WITH CONSULT-III	50
CREW CAB : Description	32	ID Code Entry Procedure	50
CREW CAB : Component Function Check	32	KEYFOB ID SET UP WITHOUT CONSULT-III.. 51	
CREW CAB : Diagnosis Procedure	32	ID Code Entry Procedure	51
KEY SWITCH (BCM INPUT)	34	HOMELINK UNIVERSAL TRANSCEIVER	53
COLUMN SHIFT	34	Description	53
COLUMN SHIFT : Diagnosis Procedure	34	Component Function Check	53
FLOOR SHIFT	35	Diagnosis Procedure	53
FLOOR SHIFT : Diagnosis Procedure	35	ECU DIAGNOSIS	55
DOOR LOCK ACTUATOR	37	BCM (BODY CONTROL MODULE)	55
FRONT LH	37	Reference Value	55
FRONT LH : Description	37	Wiring Diagram—POWER DOOR LOCK SYS- TEM (KING CAB)—	56
FRONT LH : Component Function Check	37	Wiring Diagram—POWER DOOR LOCK SYS- TEM (CREW CAB)—	64
FRONT LH : Diagnosis Procedure	37	Wiring Diagram — REMOTE KEYLESS ENTRY SYSTEM —	74
FRONT RH	37	Fail Safe	82
FRONT RH : Description	38	DTC Inspection Priority Chart	83
FRONT RH : Component Function Check	38	DTC Index	83
FRONT RH : Diagnosis Procedure	38	HOMELINK UNIVERSAL TRANSCEIVER	84
REAR RH/LH	38	Wiring Diagram	84
REAR RH/LH : Description	38	SYMPTOM DIAGNOSIS	86
REAR RH/LH : Component Function Check	39	DOOR LOCK	86
REAR RH/LH : Diagnosis Procedure	39	Symptom Table	86
REMOTE KEYLESS ENTRY RECEIVER	40	REMOTE KEYLESS ENTRY SYSTEM	87
Description	40	Symptom Table	87
Component Function Check	40	HOMELINK UNIVERSAL TRANSCEIVER	89
Diagnosis Procedure	40	Symptom Table	89
Component Inspection	42	SQUEAK AND RATTLE TROUBLE DIAG- NOSES	90
Special Repair Requirement	43	Work Flow	90
HORN FUNCTION	44	Generic Squeak and Rattle Troubleshooting	92
Description	44	Diagnostic Worksheet	94
Component Function Check	44		
Diagnosis Procedure	44		

PRECAUTION	96	Removal and Installation of Hood Lock Control ...	101	
		Hood Lock Control Inspection	102	A
PRECAUTIONS	96	DOOR	103	
Precaution for Supplemental Restraint System (SRS) "AIR BAG" and "SEAT BELT PRE-TEN- SIONER"	96	Fitting Adjustment	103	B
Precaution for work	96	Removal and Installation	105	B
PREPARATION	97	FRONT DOOR LOCK	108	
PREPARATION	97	Component Structure	108	C
Special Service Tool	97	Removal and Installation	108	
Commercial Service Tool	98	Disassembly and Assembly	110	
ON-VEHICLE REPAIR	99	REAR DOOR LOCK	111	D
HOOD	99	Component Structure	111	
Fitting Adjustment	99	Removal and Installation	112	E
Removal and Installation of Hood Assembly	100	TAIL GATE	115	
		Removal and Installation	115	F

DLK

L
M
N
O
P

DIAGNOSIS AND REPAIR WORKFLOW

< BASIC INSPECTION >

BASIC INSPECTION

DIAGNOSIS AND REPAIR WORKFLOW

Work Flow

INFOID:000000001546873

OVERALL SEQUENCE

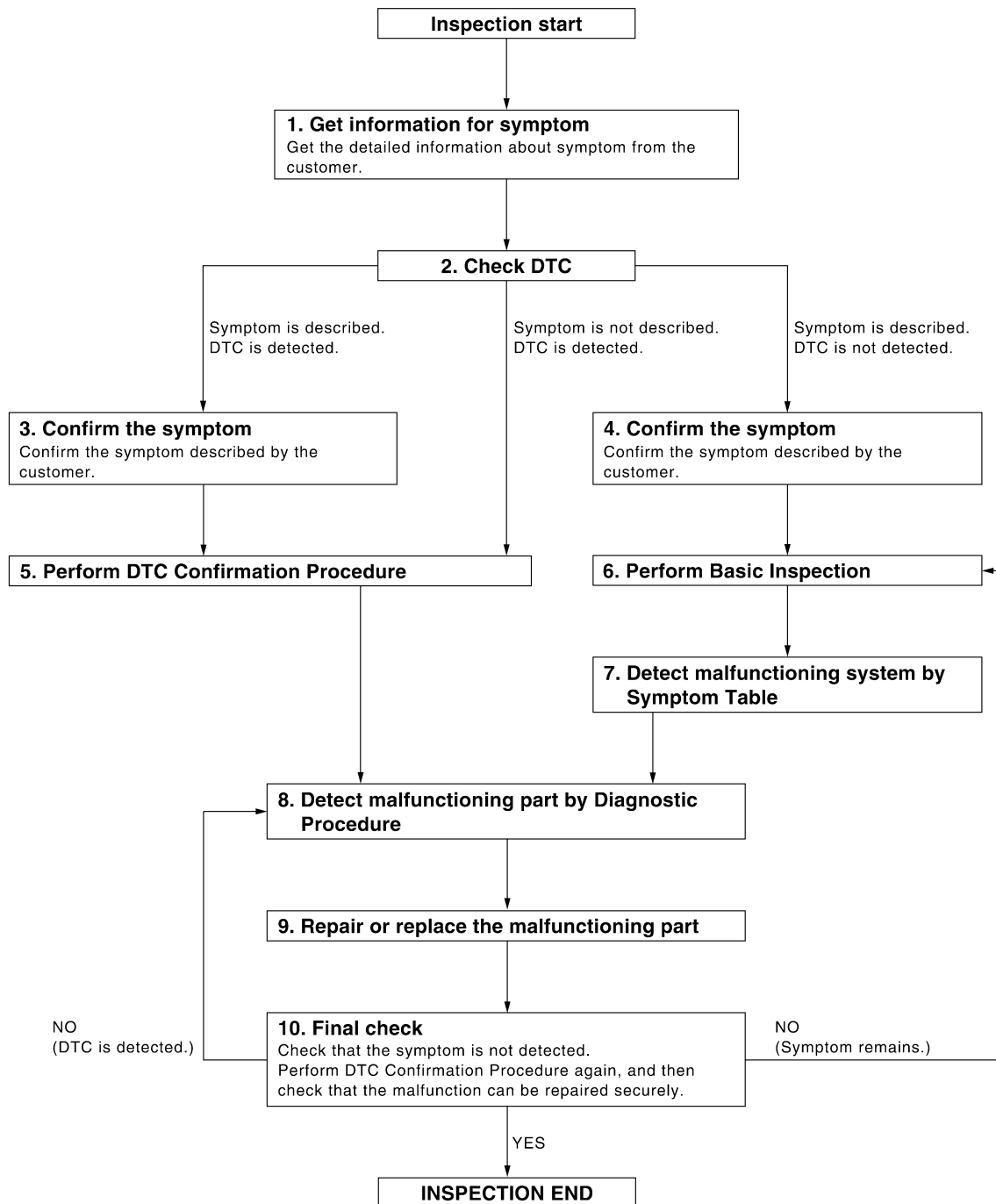

DETAILED FLOW

ALKIA0246GB

DIAGNOSIS AND REPAIR WORKFLOW

< BASIC INSPECTION >

1.GET INFORMATION FOR SYMPTOM

Get the detailed information from the customer about the symptom (the condition and the environment when the incident/malfunction occurred).

>> GO TO 2.

2.CHECK DTC

1. Check DTC.
2. Perform the following procedure if DTC is displayed.
 - Record DTC and freeze frame data (Print them out with CONSULT-III.)
 - Erase DTC.
 - Study the relationship between the cause detected by DTC and the symptom described by the customer.
3. Check related service bulletins for information.

Is any symptom described and any DTC detected?

- Symptom is described, DTC is displayed>>GO TO 3.
- Symptom is described, DTC is not displayed>>GO TO 4.
- Symptom is not described, DTC is displayed>>GO TO 5.

3.CONFIRM THE SYMPTOM

Confirm the symptom described by the customer.
Connect CONSULT-III to the vehicle in "DATA MONITOR" mode and check real time diagnosis results.
Verify relation between the symptom and the condition when the symptom is detected.

>> GO TO 5.

4.CONFIRM THE SYMPTOM

Confirm the symptom described by the customer.
Connect CONSULT-III to the vehicle in "DATA MONITOR" mode and check real time diagnosis results.
Verify relation between the symptom and the condition when the symptom is detected.

>> GO TO 6.

5.PERFORM DTC CONFIRMATION PROCEDURE

Perform DTC Confirmation Procedure for the displayed DTC, and then check that DTC is detected again.
At this time, always connect CONSULT-III to the vehicle, and check diagnostic results in real time.
If two or more DTCs are detected, refer to [DLK-83. "DTC Inspection Priority Chart"](#) and determine trouble diagnosis order.

NOTE:

- Freeze frame data is useful if the DTC is not detected.
- Perform Component Function Check if DTC Confirmation Procedure is not included in Service Manual. This simplified check procedure is an effective alternative though DTC cannot be detected during this check.
If the result of Component Function Check is NG, it is the same as the detection of DTC by DTC Confirmation Procedure.

Is DTC detected?

- Yes >> GO TO 8.
- No >> Refer to [GI-41. "Intermittent Incident"](#).

6.PERFORM BASIC INSPECTION

Perform [DLK-4. "Work Flow"](#).

Inspection End>>GO TO 7.

7.DETECT MALFUNCTIONING SYSTEM BY SYMPTOM TABLE

Detect malfunctioning system according to [DLK-86. "Symptom Table"](#) based on the confirmed symptom in step 4, and determine the trouble diagnosis order based on possible causes and symptom.

>> GO TO 8.

A
B
C
D
E
F
G
H
I
J
L
M
N
O
P

DLK

DIAGNOSIS AND REPAIR WORKFLOW

< BASIC INSPECTION >

8. DETECT MALFUNCTIONING PART BY DIAGNOSTIC PROCEDURE

Inspect according to Diagnostic Procedure of the system.

NOTE:

The Diagnostic Procedure described based on open circuit inspection. A short circuit inspection is also required for the circuit check in the Diagnostic Procedure.

Is malfunctioning part detected?

Yes >> GO TO 9.

No >> Check voltage of related BCM terminals using CONSULT-III.

9. REPAIR OR REPLACE THE MALFUNCTIONING PART

1. Repair or replace the malfunctioning part.
2. Reconnect parts or connectors disconnected during Diagnostic Procedure again after repair and replacement.
3. Check DTC. If DTC is displayed, erase it.

>> GO TO 10.

10. FINAL CHECK

When DTC was detected in step 2, perform DTC Confirmation Procedure or Component Function Check again, and then check that the malfunction have been repaired securely.

When symptom was described from the customer, refer to confirmed symptom in step 3 or 4, and check that the symptom is not detected.

OK or NG

NG (DTC is detected)>>GO TO 8.

NG (Symptom remains)>>GO TO 6.

OK >> **INSPECTION END**

INSPECTION AND ADJUSTMENT

< BASIC INSPECTION >

INSPECTION AND ADJUSTMENT

ADDITIONAL SERVICE WHEN REPLACING CONTROL UNIT

A

ADDITIONAL SERVICE WHEN REPLACING CONTROL UNIT : Description

INFOID:000000001546874

B

Perform the system initialization when replacing BCM, replacing Intelligent Key or registering an additional Intelligent Key.

C

ADDITIONAL SERVICE WHEN REPLACING CONTROL UNIT : Special Repair Requirement

INFOID:000000001546875

D

Refer to the CONSULT-III operation manual for the initialization procedure.

E

F

G

H

I

J

DLK

L

M

N

O

P

DOOR LOCK FUNCTION

< FUNCTION DIAGNOSIS >

FUNCTION DIAGNOSIS

DOOR LOCK FUNCTION

DOOR LOCK AND UNLOCK SWITCH

DOOR LOCK AND UNLOCK SWITCH : System Diagram

INFOID:000000001546876

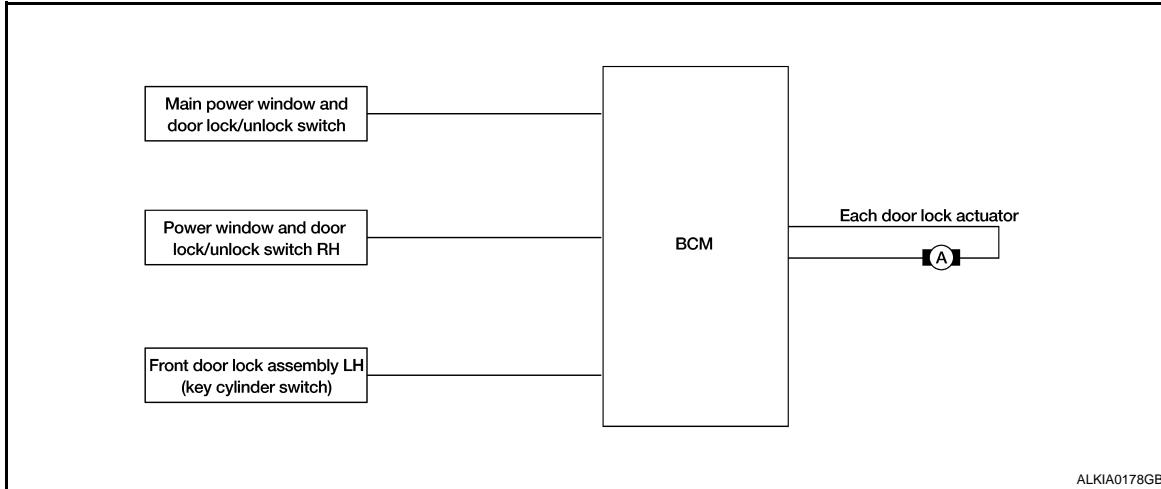

ALKIA0178GB

DOOR LOCK AND UNLOCK SWITCH : System Description

INFOID:000000001546877

Switch	Input/output signal to BCM	BCM function	Actuator
Main power window and door lock/unlock switch	Door lock/unlock signal	Door lock/unlock control	Door lock actuator
Power window and door lock/unlock switch			
Door key cylinder switch			

DOOR LOCK FUNCTION

Functions Available by Operating the Door Lock and Unlock Switches on Driver Door and Passenger Door

- Interlocked with the locking operation of door lock and unlock switch, door lock actuators of all door lock actuators are locked.
- Interlocked with the unlocking operation of door lock and unlock switch, door lock actuators of all door lock actuators are unlocked.

Functions Available by Operating the Key Cylinder Switch on Driver Door

- Interlocked with the locking operation of door key cylinder, door lock actuators of all door lock actuators are locked.

Selective Unlock Operation

- When door key cylinder is unlocked, door lock actuator driver side is unlocked.
- When door key cylinder is unlocked for the second time within 5 seconds after the first operation, door lock actuators on all doors are unlocked.

Select unlock operation mode can be changed using DOOR LOCK-UNLOCK SET mode in "WORK SUPPORT". Refer to [DLK-15. "DOOR LOCK : CONSULT-III Function \(BCM - DOOR LOCK\)".](#)

Key Reminder System

Refer to [DLK-15. "COMMON ITEM : CONSULT-III Function \(BCM - COMMON ITEM\)".](#)

DOOR LOCK FUNCTION

< FUNCTION DIAGNOSIS >

DOOR LOCK AND UNLOCK SWITCH : Component Parts Location

INFOID:000000001546878

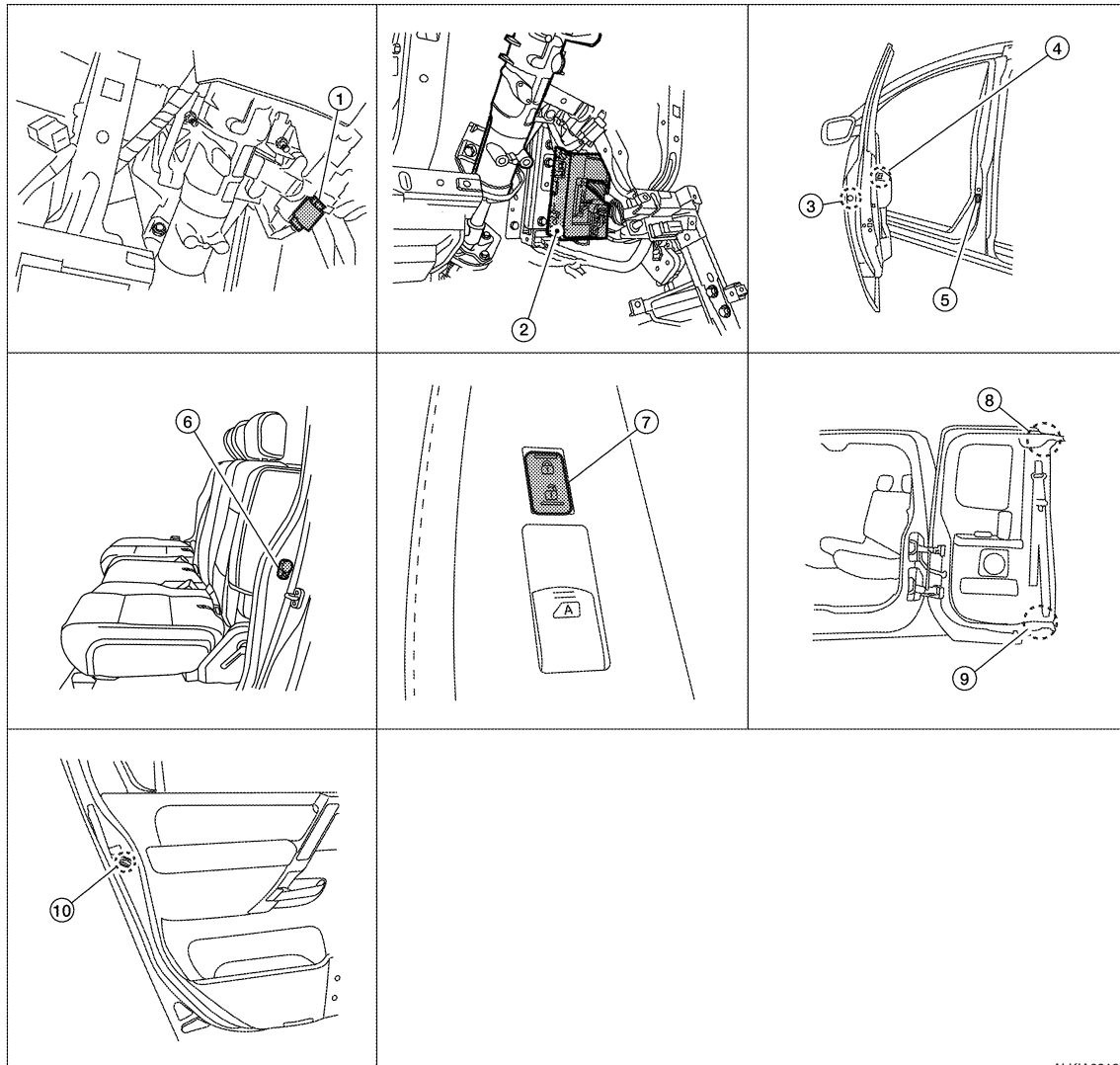

- | | | |
|--|--|--|
| <p>1. Key switch and key lock solenoid (floor shift) M27
Key switch (column shift) M80</p> <p>4. Main power window and door lock/unlock switch D7, D8</p> <p>7. Power window and door lock/unlock switch RH D105</p> <p>10. Rear door lock actuator (crew cab)
LH D205
RH D305</p> | <p>2. BCM M18, M19, M20
(view with instrument panel LH removed)</p> <p>5. Front door switch
LH B8
RH B108</p> <p>8. Rear door switch upper (king cab)
LH B73
RH B156</p> | <p>3. Front door lock assembly LH (key cylinder switch) D14
Front door lock actuator RH D114</p> <p>6. Rear door switch (crew cab)
LH B18
RH B116</p> <p>9. Rear door switch lower (king cab)
LH B74
RH B157</p> |
|--|--|--|

ALKIA0918ZZ

DOOR LOCK AND UNLOCK SWITCH : Component Description

INFOID:000000001546879

Item	Function
BCM	Controls the door lock function and room lamp function.
Door lock and unlock switch	Transmits lock or unlock signal to BCM.

DOOR LOCK FUNCTION

< FUNCTION DIAGNOSIS >

Item	Function
Door lock actuator	Receives lock/unlock signal from BCM and locks/unlocks each door.
Door switch	Transmits door open/close condition to BCM.

REMOTE KEYLESS ENTRY

REMOTE KEYLESS ENTRY : System Diagram

INFOID:000000001546880

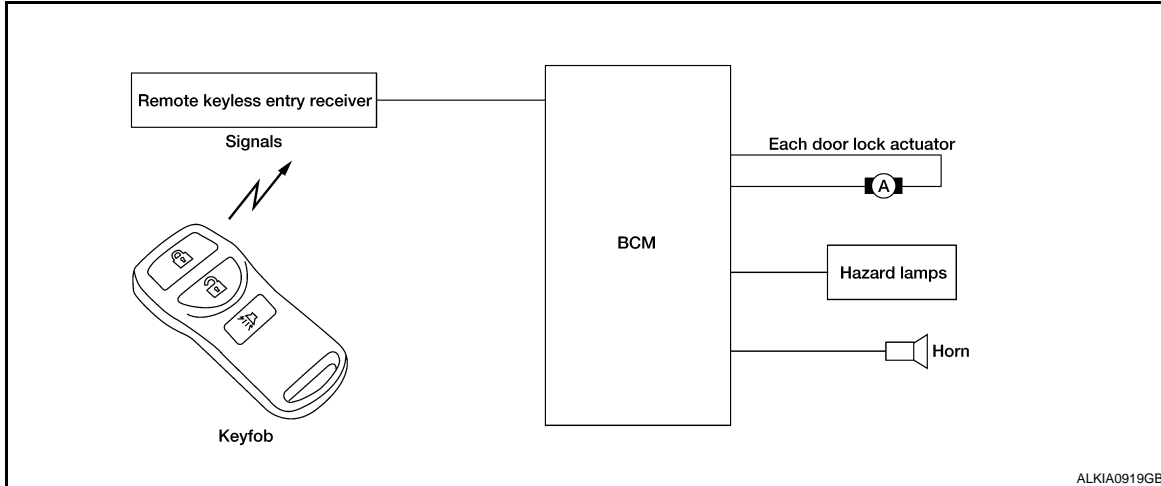

ALKIA0919GB

REMOTE KEYLESS ENTRY : System Description

INFOID:000000001546881

OPERATED PROCEDURE

- When the keyfob is operated, the signal from the keyfob is sent and the remote keyless entry receiver receives the signal and sends it to the BCM. The BCM only locks/unlocks the doors if the ID number matches. (Remote control entry functions)
- Using the keyfob, the transmitter sends radio waves to the remote keyless entry receiver, which then sends the received waves to the BCM. Only if the ID number matches does the BCM lock/unlock the doors. (Remote control door function)
- Unless the key is inserted into the ignition key cylinder or one of the doors is opened within 1 minute after the UNLOCK switch on the keyfob is pressed, all the doors are automatically locked. (Auto lock function)
- When a door is locked or unlocked, the vehicle turn signal lamps flash and the horn sounds to verify operation. (Active check function)
- When the key is in the ignition key cylinder (when the key switch is ON) and one of the doors is open, the door lock function does not work even when the door lock is operated with the keyfob.
- Keyfob ID set up is available.
- If a keyfob is lost, a new keyfob can be set up. A maximum of 5 IDs can be set up simultaneously.

REMOTE CONTROL ENTRY FUNCTIONS

- When a button on the keyfob is operated, the signal is sent from the keyfob and received by the remote keyless entry receiver.
- The received signal is sent to the BCM and compared with the registered ID number.
- If the ID number matches, the BCM sends the lock/unlock signal to each door lock actuator.
- When the door lock actuators receive this signal, each operates to lock/unlock its door.
- BCM locks all doors with input of LOCK signal from keyfob.
- When an UNLOCK signal is sent from keyfob once, driver's door will be unlocked.
- Then, if an UNLOCK signal is sent from keyfob again within 5 seconds, all other doors will be unlocked.

REMOTE CONTROL ENTRY OPERATION CONDITIONS

Keyfob operation	Operation condition
Door lock operation (locking)	<ul style="list-style-type: none"> • With key removed (key switch: OFF) • Closing all doors (door switch: OFF)
Door lock operation (unlocking)	With key removed (key switch: OFF)

DOOR LOCK FUNCTION

< FUNCTION DIAGNOSIS >

AUTO LOCK FUNCTION

Operation Description

- Unless the key is inserted into the ignition key cylinder, one of the doors is opened, or the keyfob is operated within 1 minute after a door lock is unlocked by keyfob operation, all the doors are automatically locked. The 1 minute timer count is executed by the BCM and after 1 minute, the BCM sends the lock signal to all doors. Lock operations are the same as for the remote control entry function.

ACTIVE CHECK FUNCTION

Operation Description

When a door is locked or unlocked by keyfob operation, the vehicle turn signals flash and the horn sounds to verify operation.

- When a button on the keyfob is operated, the signal is sent from the remote controller and received by the keyless remote entry receiver.
- The received signal is sent to the BCM and compared with the registered ID number.
- If the ID number matches, the BCM uses communication to send the turn signal flashing and horn signal to the IPDM E/R.
- The IPDM E/R flashes the turn signal lamps and sounds the horn for each keyfob operation.

Operating function of hazard and horn reminder

	C mode		S mode	
	Lock	Unlock	Lock	Unlock
Keyfob operation	Lock	Unlock	Lock	Unlock
Hazard warning lamp flash	Twice	Once	Twice	—
Horn sound	Once	—	—	—

HAZARD AND HORN REMINDER

BCM output to IPDM E/R for horn reminder signal as DATA LINE (CAN-H line and CAN-L line). The hazard and horn reminder has C mode (horn chirp mode) and S mode (non-horn chirp mode).

How to change hazard and horn reminder mode

 With CONSULT-III

Hazard and horn reminder can be changed using "WORK SUPPORT" mode in "MULTI ANSWER BACK SET".

 Without CONSULT-III

Refer to Owner's Manual for instructions.

INTERIOR LAMP OPERATION

When the following input signals are both supplied:

- all door switches are in the OFF position. (when all the doors are closed);
- interior lamp switch is in DOOR position.

Remote keyless entry system turns on interior lamp and ignition keyhole illumination (for 30 seconds) with input of UNLOCK signal from keyfob.

PANIC ALARM OPERATION

When key switch is OFF (when ignition key is not inserted in key cylinder), remote keyless entry system turns on and off horn and headlamp intermittently with input of PANIC ALARM signal from keyfob.

The alarm automatically turns off after 25 seconds or when BCM receives any signal from keyfob.

KEYLESS POWER WINDOW DOWN (OPEN) OPERATION

When keyfob unlock switch is turned ON with ignition switch OFF, and the switch is detected to be ON continuously for more than 1 second, the driver's door and passenger's door power windows are simultaneously opened.

Power window is operated to open and the operation continues as long as the keyfob unlock switch is pressed.

DOOR LOCK FUNCTION

< FUNCTION DIAGNOSIS >

REMOTE KEYLESS ENTRY : Component Parts Location

INFOID:000000001546882

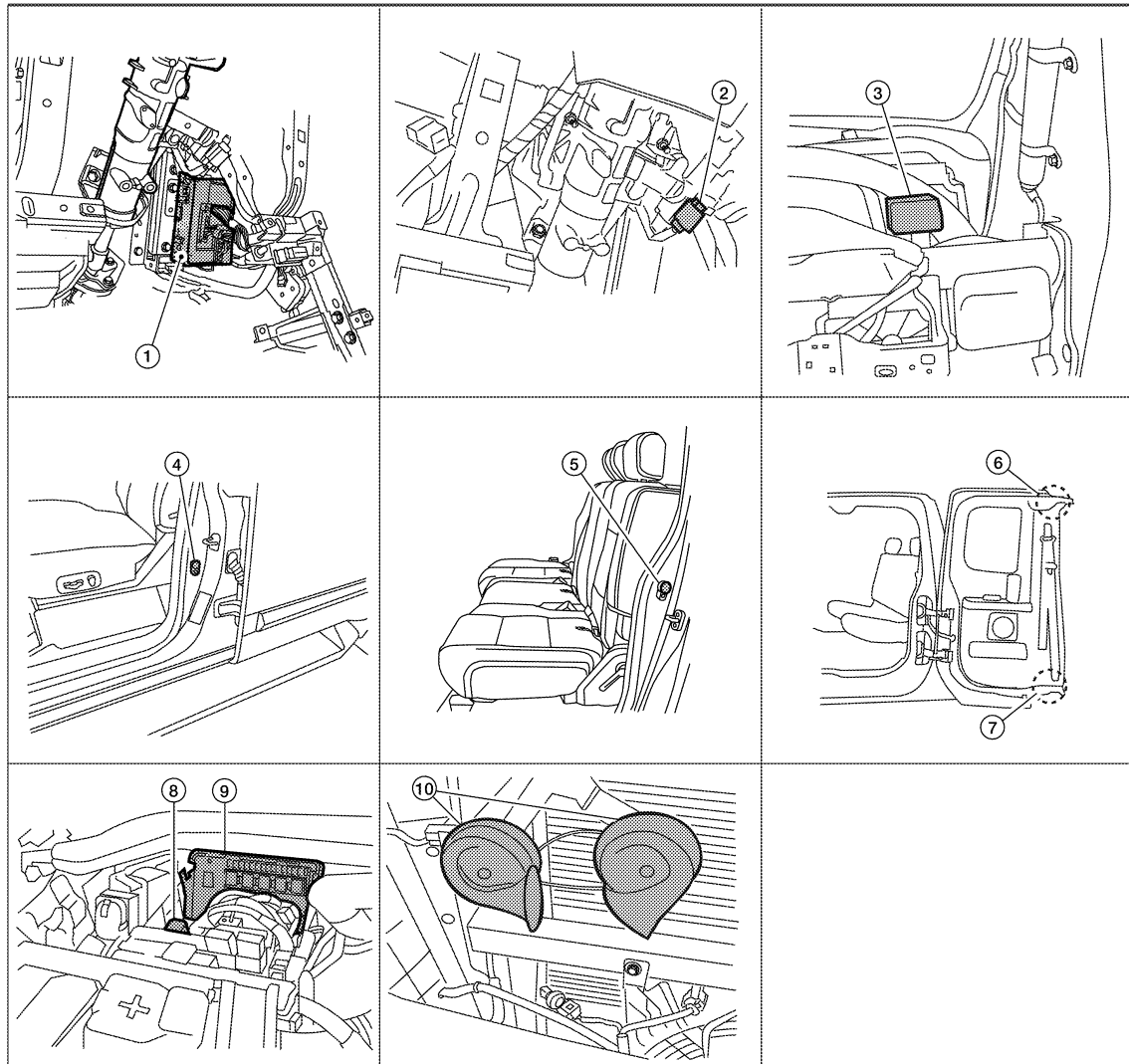

ALKIA0920ZZ

- | | | |
|--|--|---|
| <p>1. BCM M18, M19, M20
(view with instrument panel LH removed)</p> <p>4. Front door switch LH B8
RH B108</p> <p>7. Rear door switch lower (king cab)
LH B74
RH B157</p> <p>10. Horn E3
(view with grille removed)</p> | <p>2. Key switch and key lock solenoid (floor shift) M27
Key switch (column shift) M80
(view with instrument panel LH removed)</p> <p>5. Rear door switch (crew cab)
LH B18
RH B116</p> <p>8. Horn relay H-1
(view with cover removed)</p> | <p>3. Remote keyless entry receiver M120
(view with instrument panel RH removed)</p> <p>6. Rear door switch upper (king cab)
LH B73
RH B156</p> <p>9. IPDM E/R E119, E122, E123</p> |
|--|--|---|

REMOTE KEYLESS ENTRY : Component Description

INFOID:000000001546883

Item	Function
BCM	Controls the door lock function and room lamp function.
Door lock and unlock switch	Transmits lock or unlock signal to BCM.

DOOR LOCK FUNCTION

< FUNCTION DIAGNOSIS >

Item	Function
Door switch	Transmits door open/close condition to BCM.
Remote keyless entry receiver	Receives lock/unlock signal from the keyfob, and then transmits to BCM.

A

B

C

D

E

F

G

H

I

J

DLK

L

M

N

O

P

HOMELINK UNIVERSAL TRANSCEIVER

< FUNCTION DIAGNOSIS >

HOMELINK UNIVERSAL TRANSCEIVER

Component Description

INFOID:000000001546888

Item	Function	Reference page
Homelink universal transceiver	A maximum of 3 radio signals can be stored and transmitted to operate the garage door, etc.	Refer to Owner's Manual

DIAGNOSIS SYSTEM (BCM)

< FUNCTION DIAGNOSIS >

DIAGNOSIS SYSTEM (BCM)

COMMON ITEM

COMMON ITEM : CONSULT-III Function (BCM - COMMON ITEM)

INFOID:000000001546889

APPLICATION ITEM

CONSULT-III performs the following functions via CAN communication with BCM.

Diagnosis mode	Function Description
WORK SUPPORT	Changes the setting for each system function.
SELF-DIAG RESULTS	Displays the diagnosis results judged by BCM. Refer to DLK-83. "DTC Index" .
CAN DIAG SUPPORT MNTR	Monitors the reception status of CAN communication viewed from BCM.
DATA MONITOR	The BCM input/output signals are displayed.
ACTIVE TEST	The signals used to activate each device are forcibly supplied from BCM.
ECU IDENTIFICATION	The BCM part number is displayed.
CONFIGURATION	This function is not used even though it is displayed.

SYSTEM APPLICATION

BCM can perform the following functions for each system.

NOTE:

It can perform the diagnosis modes except the following for all subsystem selection items.

System	Sub system selection item	Diagnosis mode		
		WORK SUPPORT	DATA MONITOR	ACTIVE TEST
Door lock	DOOR LOCK	×	×	×
Warning chime	BUZZER		×	×
Interior room lamp timer	INT LAMP	×	×	×
Turn signal and hazard warning lamps	FLASHER	×	×	×
BCM	BCM	×		
Interior room lamp battery saver	BATTERY SAVER	×	×	×
Back door open	TRUNK		×	
RAP system	RETAINED PWR		×	

DLK

DOOR LOCK

DOOR LOCK : CONSULT-III Function (BCM - DOOR LOCK)

INFOID:000000001546890

BCM CONSULT-III FUNCTION

CONSULT-III performs the following functions via CAN communication with BCM.

Diagnosis mode	Function Description
WORK SUPPORT	Changes the setting for each system function.
DATA MONITOR	The BCM input/output signals are displayed.
ACTIVE TEST	The signals used to activate each device are forcibly supplied from BCM.

WORK SUPPORT

Monitor item	Description
DOOR LOCK-UNLOCK SET	Selective unlock function mode can be changed to operate (WITH) or not operate (WITHOUT) with this mode.

DATA MONITOR

DIAGNOSIS SYSTEM (BCM)

< FUNCTION DIAGNOSIS >

Monitor Item	Contents
DOOR SW-DR	Indicates [ON/OFF] condition of front door switch (driver side).
DOOR SW-AS	Indicates [ON/OFF] condition of front door switch (passenger side).
DOOR SW-RR	Indicates [ON/OFF] condition of rear door switch RH.
DOOR SW-RL	Indicates [ON/OFF] condition of rear door switch LH.
CDL LOCK SW	Indicates [ON/OFF] condition of lock signal from door lock unlock switch.
CDL UNLOCK SW	Indicates [ON/OFF] condition of unlock signal from door lock unlock switch.
KEY CYL LK-SW	Indicates [ON/OFF] condition of lock signal from key cylinder.
KEY CYL UN-SW	Indicates [ON/OFF] condition of unlock signal from key cylinder.

ACTIVE TEST

Test item	Description
DOOR LOCK	<p>This test is able to check door lock/unlock operation.</p> <ul style="list-style-type: none"> • The all door lock actuators are locked when "LOCK" on CONSULT-III screen is touched. • The all door lock actuators are unlocked when "ALL UNLK" on CONSULT-III screen is touched. • The door lock actuator (driver side) is unlocked when "DR UNLK" on CONSULT-III screen is touched. • The door lock actuator (passenger side) is unlocked when "AS UNLK" on CONSULT- III screen is touched. • The door lock actuator (other) is unlocked when "OTR ULK" on CONSULT-III screen is touched.

REMOTE KEYLESS ENTRY

REMOTE KEYLESS ENTRY : CONSULT-III Function (BCM - RKE)

INFOID:000000001546891

"MULTI REMOTE ENT"

Data Monitor

Monitored Item	Description
DOOR SW-AS	Indicates [ON/OFF] condition of front door switch RH.
DOOR SW-RR	Indicates [ON/OFF] condition of rear door switch RH.
DOOR SW-RL	Indicates [ON/OFF] condition of rear door switch LH.
DOOR SW-DR	Indicates [ON/OFF] condition of front door switch LH.
KEY ON SW	Indicates [ON/OFF] condition of key switch.
ACC ON SW	Indicates [ON/OFF] condition of ignition switch in ACC position.
IGN ON SW	Indicates [ON/OFF] condition of ignition switch in ON position.
KEYLESS PANIC	Indicates [ON/OFF] condition of panic signal from keyfob.
KEYLESS UNLOCK	Indicates [ON/OFF] condition of unlock signal from keyfob.
KEYLESS LOCK	Indicates [ON/OFF] condition of lock signal from keyfob.
KEY CYL LK-SW	Indicates [ON/OFF] condition of lock signal from door key cylinder switch.
KEY CYL UN-SW	Indicates [ON/OFF] condition of unlock signal from door key cylinder switch.
CDL UNLOCK SW	Indicates [ON/OFF] condition of unlock signal from lock/unlock switch.
CDL LOCK SW	Indicates [ON/OFF] condition of lock signal from lock/unlock switch.
DOOR SW-RL	Indicates [ON/OFF] condition of rear door switch LH.
DOOR SW-RR	Indicates [ON/OFF] condition of rear door switch RH.
RKE LCK-UNLCK	Indicates [ON/OFF] condition of lock/unlock signal at the same time from keyfob.
RKE KEEP UNLK	Indicates [ON/OFF] condition of unlock signal from keyfob.

Active Test

DIAGNOSIS SYSTEM (BCM)

< FUNCTION DIAGNOSIS >

Test Item	Description
FLASHER	This test is able to check right and left hazard reminder operation. The right hazard lamp turns on when "RH" on CONSULT-III screen is touched and the left hazard lamp turns on when "LH" on CONSULT-III screen is touched.
POWER WINDOW DOWN	This test is able to check power window down operation. The windows are lowered when "ON" on CONSULT-III screen is touched.
HORN	This test is able to check panic alarm and horn reminder operations. The alarm activate for 0.5 seconds after "ON" on CONSULT-III screen is touched.
DOOR LOCK	This test is able to check door lock operation. The doors lock and unlock based on the item on CONSULT-III screen touched.

Work Support

Test Item	Description
REMO CONT ID REGIST	Keyfob ID code can be registered.
REMO CONT ID ERASUR	Keyfob ID code can be erased.
REMO CONT ID CONFIR	It can be checked whether keyfob ID code is registered or not in this mode.
HORN CHIRP SET	Horn chirp function mode can be changed in this mode. The function mode will be changed when "CHANG SETT" on CONSULT-III screen is touched.
HAZARD LAMP SET	Hazard lamp function mode can be changed in this mode. The function mode will be changed when "CHANG SETT" on CONSULT-III screen is touched.
MULTI ANSWER BACK SET	Hazard and horn reminder mode can be changed in this mode. The reminder mode will be changed when "CHANG SETT" on CONSULT-III screen is touched.
AUTO LOCK SET	Auto locking function mode can be changed in this mode. The function mode will be changed when "CHANG SETT" on CONSULT-III screen is touched.
PANIC ALRM SET	Panic alarm operation mode can be changed in this mode. The operation mode will be changed when "CHANG SETT" on CONSULT-III screen is touched.
PW DOWN SET	Keyless power window down (open) operation mode can be changed in this mode. The operation mode will be changed when "CHANG SETT" on CONSULT-III screen is touched.

Hazard and horn reminder mode

	MODE 1 (C mode)		MODE 2 (S mode)		MODE 3		MODE 4		MODE 5		MODE 6	
	Lock	Unlock	Lock	Unlock	Lock	Unlock	Lock	Unlock	Lock	Unlock	Lock	Unlock
Keyfob operation	Lock	Unlock	Lock	Unlock	Lock	Unlock	Lock	Unlock	Lock	Unlock	Lock	Unlock
Hazard warning lamp flash	Twice	Once	Twice	—	—	—	Twice	Once	Twice	—	—	Once
Horn sound	Once	—	—	—	—	—	—	—	Once	—	Once	—

Auto locking function mode

	MODE 1	MODE 2	MODE 3
Auto locking function	5 minutes	Nothing	1 minute

Panic alarm operation mode

	MODE 1	MODE 2	MODE 3
Keyfob operation	0.5 seconds	Nothing	1.5 seconds

Back door open operation mode

	MODE 1	MODE 2	MODE 3
Keyfob operation	0.5 seconds	Nothing	0.5 seconds

Keyless power window down operation mode

	MODE 1	MODE 2	MODE 3
Keyfob operation	3 seconds	Nothing	5 seconds

A
B
C
D
E
F
G
H
I
J
L
M
N
O
P

DLK

U1000 CAN COMM CIRCUIT

< COMPONENT DIAGNOSIS >

COMPONENT DIAGNOSIS

U1000 CAN COMM CIRCUIT

Description

INFOID:000000001546892

CAN (Controller Area Network) is a serial communication line for real time applications. It is an on-vehicle multiplex communication line with high data communication speed and excellent error detection ability. Modern vehicle is equipped with many electronic control unit, and each control unit shares information and links with other control units during operation (not independent). In CAN communication, control units are connected with 2 communication lines (CAN H-line, CAN L-line) allowing a high rate of information transmission with less wiring. Each control unit transmits/receives data but selectively reads required data only.

CAN Communication Signal Chart. Refer to [LAN-58, "CAN Communication Signal Chart"](#).

DTC Logic

INFOID:000000001546893

DTC DETECTION LOGIC

DTC	CONSULT-III display description	DTC Detection Condition	Possible cause
U1000	CAN COMM CIRCUIT	When BCM cannot communicate CAN communication signal continuously for 2 seconds or more.	In CAN communication system, any item (or items) of the following listed below is malfunctioning. <ul style="list-style-type: none">• Transmission• Receiving (ECM)• Receiving (VDC/TCS/ABS)• Receiving (METER/M&A)• Receiving (TCM)• Receiving (MULTI AV)• Receiving (IPDM E/R)

Diagnosis Procedure

INFOID:000000001546894

1.PERFORM SELF DIAGNOSTIC

1. Turn ignition switch ON and wait for 2 seconds or more.
2. Check "Self Diagnostic Result".

Is "CAN COMM CIRCUIT" displayed?

- YES >> Refer to [DLK-18, "Diagnosis Procedure"](#).
NO >> Refer to [GI-41, "Intermittent Incident"](#).

U1010 CONTROL UNIT (CAN)

< COMPONENT DIAGNOSIS >

U1010 CONTROL UNIT (CAN)

DTC Logic

INFOID:000000001546895

DTC DETECTION LOGIC

DTC	CONSULT-III display description	DTC Detection Condition	Possible cause
U1010	CONTROL UNIT (CAN)	BCM detected internal CAN communication circuit malfunction.	BCM

Diagnosis Procedure

INFOID:000000001546896

1.REPLACE BCM

When DTC [U1010] is detected, replace BCM.

>> Replace BCM. Refer to [BCS-50. "Removal and Installation"](#).

Special Repair Requirement

INFOID:000000001546897

1.REQUIRED WORK WHEN REPLACING BCM

The BCM must be initialized when replaced. Refer to (Body Control System) for BCM configuration. Initialize NVIS by CONSULT-III. For the details of initialization refer to CONSULT-III operation manual NATS-IVIS/NVIS.

>> Work end.

A
B
C
D
E
F
G
H
I
J
L
M
N
O
P

DLK

POWER SUPPLY AND GROUND CIRCUIT

< COMPONENT DIAGNOSIS >

POWER SUPPLY AND GROUND CIRCUIT

BCM (BODY CONTROL MODULE)

BCM (BODY CONTROL MODULE) : Diagnosis Procedure

INFOID:000000001546898

Refer to [BCS-29, "Diagnosis Procedure"](#).

DOOR SWITCH

< COMPONENT DIAGNOSIS >

DOOR SWITCH

KING CAB

KING CAB : Description

INFOID:000000001572978

Detects door open/close condition.

KING CAB : Component Function Check

INFOID:000000001572979

1.CHECK FUNCTION

With CONSULT-III

Check door switches in data monitor mode with CONSULT-III.

Monitor item	Condition
DOOR SW-DR	CLOSE → OPEN: OFF → ON
DOOR SW-AS	

Is the inspection result normal?

YES >> Door switch is OK.

NO >> Refer to [DLK-21, "KING CAB : Diagnosis Procedure"](#).

KING CAB : Diagnosis Procedure

INFOID:000000001572982

1.CHECK DOOR SWITCHES INPUT SIGNAL

With CONSULT-III

Check door switches ("DOOR SW-DR", "DOOR SW-AS") in DATA MONITOR mode with CONSULT-III. Refer to [DLK-15, "DOOR LOCK : CONSULT-III Function \(BCM - DOOR LOCK\)"](#).

• When doors are open:

DOOR SW-DR :ON

DOOR SW-AS :ON

• When doors are closed:

DOOR SW-DR :OFF

DOOR SW-AS :OFF

Without CONSULT-III

Check voltage between BCM connector M18 or M19 terminals 12, 47 and ground.

Connector	Item	Terminals		Condition	Voltage (V) (Approx.)
		(+)	(-)		
M19	Door switches LH	47	Ground	Open ↓ Closed	0 ↓ Battery voltage
M18	Door switches RH	12			

Is the inspection result normal?

YES >> Door switch circuit is OK.

NO >> GO TO 2

2.CHECK DOOR SWITCH CIRCUIT

1. Turn ignition switch OFF.
2. Disconnect door switch and BCM.

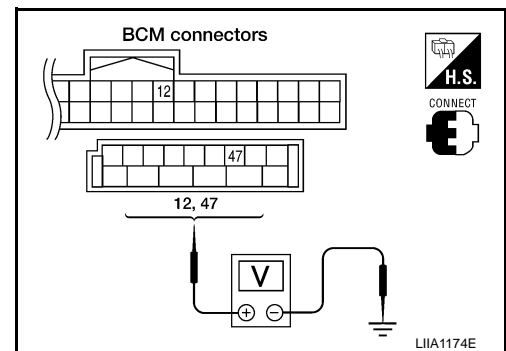

DOOR SWITCH

< COMPONENT DIAGNOSIS >

- Check continuity between door switch connector B8 (Front LH), B108 (Front RH) terminal 2, B73 (Rear upper LH), B156 (Rear upper RH), B74 (Rear lower LH), B157 (Rear lower RH) terminal 1 and BCM connector M18, M19 terminals 12, and 47.

- 2 - 47 :Continuity should exist
- 2 - 12 :Continuity should exist
- 1 - 47 :Continuity should exist
- 1 - 12 :Continuity should exist

- Check continuity between door switch connector B8 (Front LH), B108 (Front RH) terminal 2, B73 (Rear upper LH), B156 (Rear upper RH), B74 (Rear lower LH), B157 (Rear lower RH) terminal 1 and ground.

- 2 - Ground :Continuity should not exist
- 1 - Ground :Continuity should not exist

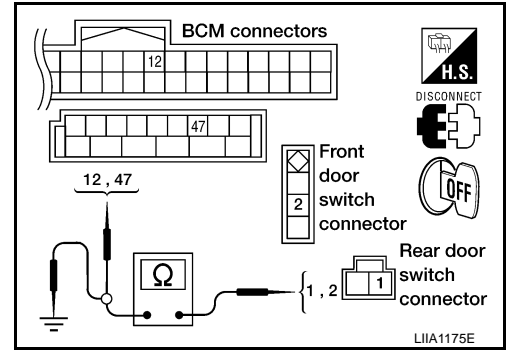

Is the inspection result normal?

- YES >> GO TO 3
- NO >> Repair or replace harness.

3.CHECK DOOR SWITCHES

Check continuity between door switch terminals.

Item	Terminals	Condition	Continuity
Door switches (front)	2 - 3	Open	No
		Closed	Yes
Door switches (rear upper and lower)	1 - 2	Open	No
		Closed	Yes

Is the inspection result normal?

- YES >> Repair or replace harness.
- NO >> Replace door switch.

CREW CAB

CREW CAB : Description

Detects door open/close condition.

CREW CAB : Component Function Check

1.CHECK FUNCTION

With CONSULT-III

Check door switches in data monitor mode with CONSULT-III.

Monitor item	Condition
DOOR SW-DR	CLOSE → OPEN: OFF → ON
DOOR SW-AS	
DOOR SW-RL	
DOOR SW-RR	

Is the inspection result normal?

- YES >> Door switch is OK.
- NO >> Refer to [DLK-23. "CREW CAB : Diagnosis Procedure"](#).

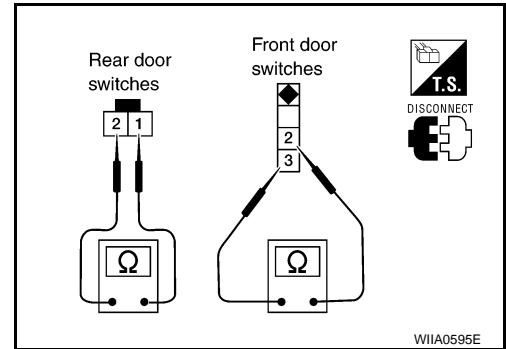

INFOID:000000001572980

INFOID:000000001572981

DOOR SWITCH

< COMPONENT DIAGNOSIS >

CREW CAB : Diagnosis Procedure

INFOID:000000001572983

1. CHECK DOOR SWITCHES INPUT SIGNAL

 With CONSULT-III

Check door switches ("DOOR SW-DR", "DOOR SW-AS", "DOOR SW-RL", "DOOR SW-RR") in DATA MONITOR mode with CONSULT-III. Refer to [DLK-15. "DOOR LOCK : CONSULT-III Function \(BCM - DOOR LOCK\)"](#).

• When doors are open:

DOOR SW-DR :ON
DOOR SW-AS :ON
DOOR SW-RL :ON
DOOR SW-RR :ON

• When doors are closed:

DOOR SW-DR :OFF
DOOR SW-AS :OFF
DOOR SW-RL :OFF
DOOR SW-RR :OFF

 Without CONSULT-III

Check voltage between BCM connector M18 or M19 terminals 12, 13, 47, 48 and ground.

Connector	Item	Terminals		Condition	Voltage (V) (Approx.)
		(+)	(-)		
M19	Front door switch LH	47	Ground	Open ↓ Closed	0 ↓ Battery voltage
	Rear door switch LH	48			
M18	Front door switch RH	12			
	Rear door switch RH	13			

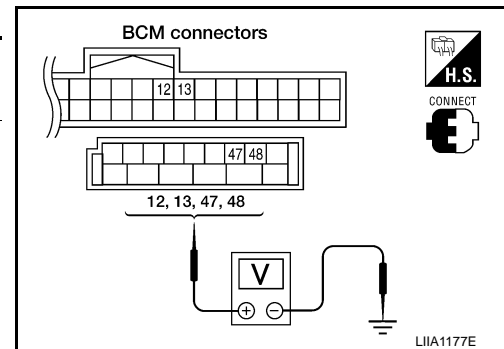

Is the inspection result normal?

YES >> Door switch circuit is OK.

NO >> GO TO 2

2. CHECK DOOR SWITCH CIRCUIT

- Turn ignition switch OFF.
- Disconnect door switch and BCM.
- Check continuity between door switch connector B8 (Front LH), B108 (Front RH), B18 (Rear LH), B116 (Rear RH) terminal 2 and BCM connector M18, M19 terminals 12, 13, 47 and 48.

2 - 47 :Continuity should exist
2 - 12 :Continuity should exist
2 - 48 :Continuity should exist
2 - 13 :Continuity should exist

- Check continuity between door switch connector B8 (Front LH), B108 (Front RH), B18 (Rear LH), B116 (Rear RH) terminal 2 and ground.

2 - Ground :Continuity should not exist

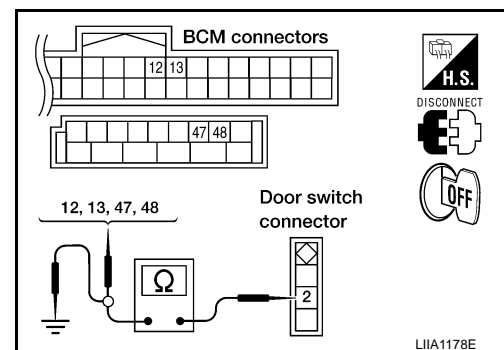

DOOR SWITCH

< COMPONENT DIAGNOSIS >

Is the inspection result normal?

YES >> GO TO 3

NO >> Repair or replace harness.

3. CHECK DOOR SWITCHES

Check continuity between door switch terminal 2 and exposed metal of switch while pressing and releasing switch.

	Terminals	Condition	Continuity
Door switch (front and rear)	2 – Ground	Released	Yes
		Pressed	No

Is the inspection result normal?

YES >> Check door switch case ground condition.

NO >> Replace door switch.

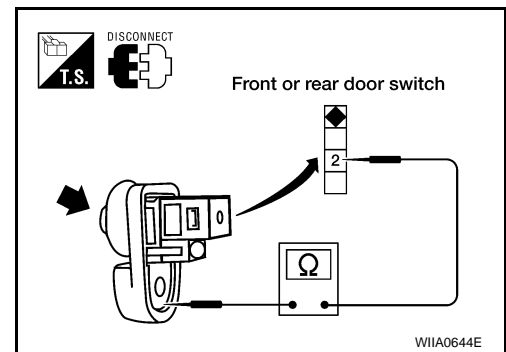

DOOR LOCK AND UNLOCK SWITCH

< COMPONENT DIAGNOSIS >

DOOR LOCK AND UNLOCK SWITCH KING CAB

KING CAB : Description

INFOID:000000001546903

Transmits door lock/unlock operation to BCM.

KING CAB : Component Function Check

INFOID:000000001546904

1. CHECK FUNCTION

 With CONSULT-III

Check CDL LOCK SW, CDL UNLOCK SW in Data Monitor mode with CONSULT-III.

Monitor item	Condition
CDL LOCK SW	LOCK : ON
	UNLOCK : OFF
CDL UNLOCK SW	LOCK : OFF
	UNLOCK : ON

Is the inspection result normal?

- YES >> Door lock and unlock switch is OK.
 NO >> refer to [DLK-25, "KING CAB : Diagnosis Procedure"](#).

KING CAB : Diagnosis Procedure

INFOID:000000001572984

1. CHECK DOOR LOCK/UNLOCK SWITCH INPUT SIGNAL

 With CONSULT-III

Check door lock/unlock switch ("CDL LOCK SW", "CDL UNLOCK SW") in DATA MONITOR mode in CONSULT-III. Refer to [DLK-15, "DOOR LOCK : CONSULT-III Function \(BCM - DOOR LOCK\)"](#).

- When door lock/unlock switch is turned to LOCK:

CDL LOCK SW : ON

- When door lock/unlock switch is turned to UNLOCK:

CDL UNLOCK SW : ON

 Without CONSULT-III

- Remove key from ignition key cylinder.
- Check the signal between BCM connector M18 terminal 22 and ground with oscilloscope when door lock/unlock switch is turned to LOCK or UNLOCK.
- Make sure the signals which are shown in the figure below can be detected during 10 seconds just after the door lock/unlock switch is turned to LOCK or UNLOCK.

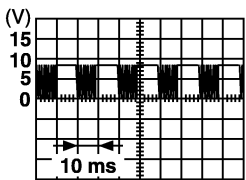
Connector	Terminals		Signal (Reference value)
	(+)	(-)	
M18	22	Ground	 <p>PIIA1297E</p>

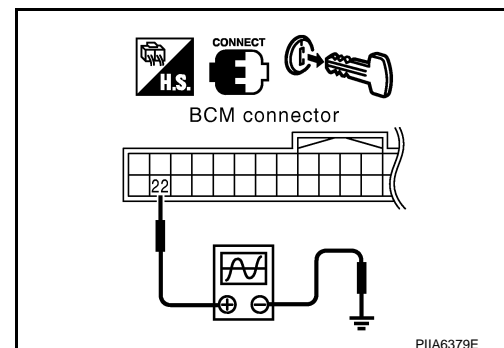

Is the inspection result normal?

- YES >> Door lock and unlock switch circuit is OK.

A
B
C
D
E
F
G
H
I
J
L
M
N
O
P

DLK

DOOR LOCK AND UNLOCK SWITCH

< COMPONENT DIAGNOSIS >

NO >> GO TO 2

2. CHECK BCM OUTPUT SIGNAL

Check ("POWER WINDOW DOWN") in ACTIVE TEST mode for "MULTI REMOTE ENT" with CONSULT-III. Refer to [DLK-15, "DOOR LOCK : CONSULT-III Function \(BCM - DOOR LOCK\)"](#).

When "ACTIVE TEST" is performed, are the front windows lowered?

Is the inspection result normal?

YES >> GO TO 3

NO >> Replace BCM. Refer to [BCS-50, "Removal and Installation"](#).

3. CHECK DOOR LOCK/UNLOCK SWITCH GROUND HARNESS

1. Turn ignition switch OFF.
2. Disconnect main power window and door lock/unlock switch or power window and door lock/unlock switch RH.
3. Check continuity between main power window and door lock/unlock switch connector D7 terminal 15 and ground.

15 - Ground : Continuity should exist

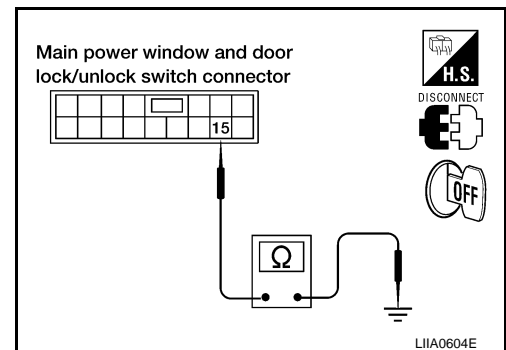

4. Check continuity between power window and door lock/unlock switch RH connector D105 terminal 11 and ground.

11 - Ground : Continuity should exist

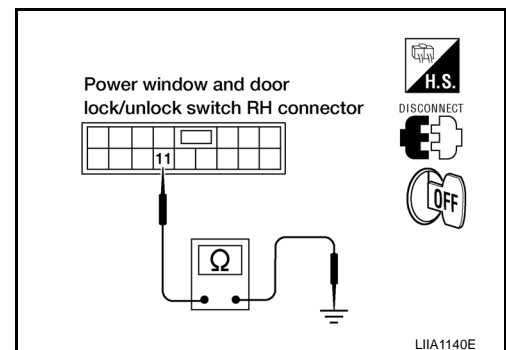

Is the inspection result normal?

YES >> GO TO 4

NO >> Repair or replace harness.

4. CHECK POWER WINDOW SERIAL LINK CIRCUIT

1. Disconnect BCM.
2. Check continuity between BCM connector M18 terminal 22 and main power window and door lock/unlock switch connector D7 terminal 12.

22 - 12 : Continuity should exist

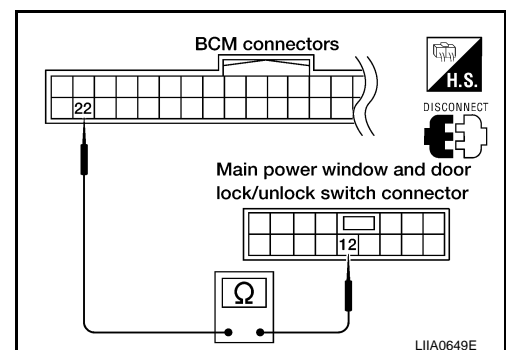

3. Check continuity between BCM connector M18 terminal 22 and power window and door lock/unlock switch RH connector D105 terminal 16.

DOOR LOCK AND UNLOCK SWITCH

< COMPONENT DIAGNOSIS >

22 - 16 : Continuity should exist

Is the inspection result normal?

- YES >> Replace main power window and door lock/unlock switch or power window and door lock/unlock switch RH.
- NO >> Repair or replace harness.

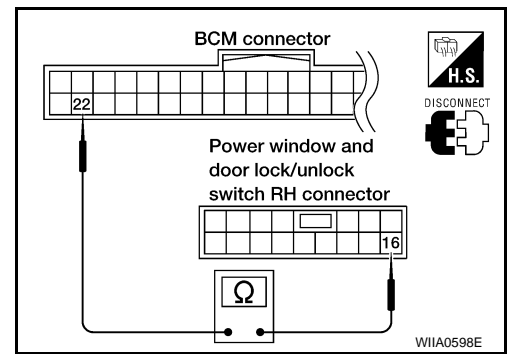

CREW CAB

CREW CAB : Description

Transmits door lock/unlock operation to BCM.

CREW CAB : Component Function Check

1. CHECK FUNCTION

With CONSULT-III

Check CDL LOCK SW, CDL UNLOCK SW in Data Monitor mode with CONSULT-III.

Monitor item	Condition
CDL LOCK SW	LOCK : ON
	UNLOCK : OFF
CDL UNLOCK SW	LOCK : OFF
	UNLOCK : ON

Is the inspection result normal?

- YES >> Door lock and unlock switch is OK.
- NO >> Refer to [DLK-27, "CREW CAB : Diagnosis Procedure"](#).

CREW CAB : Diagnosis Procedure

1. CHECK DOOR LOCK/UNLOCK SWITCH INPUT SIGNAL

With CONSULT-III

Check door lock/unlock switch ("CDL LOCK SW", "CDL UNLOCK SW") in DATA MONITOR mode in CONSULT-III. Refer to [DLK-15, "DOOR LOCK : CONSULT-III Function \(BCM - DOOR LOCK\)"](#).

- When door lock/unlock switch is turned to LOCK:

CDL LOCK SW : ON

- When door lock/unlock switch is turned to UNLOCK:

CDL UNLOCK SW : ON

Without CONSULT-III

1. Remove key from ignition key cylinder.
2. Check the signal between BCM connector M18 terminal 22 and ground with oscilloscope when door lock/unlock switch is turned to LOCK or UNLOCK.
3. Make sure the signals which are shown in the figure below can be detected during 10 seconds just after the door lock/unlock switch is turned to LOCK or UNLOCK.

A
B
C
D
E
F
G
H
I
J
L
M
N
O
P

DLK

INFOID:000000001546906
INFOID:000000001546907

INFOID:000000001572985

DOOR LOCK AND UNLOCK SWITCH

< COMPONENT DIAGNOSIS >

Connector	Terminals		Signal (Reference value)
	(+)	(-)	
M18	22	Ground	<p>PIIA1297E</p>

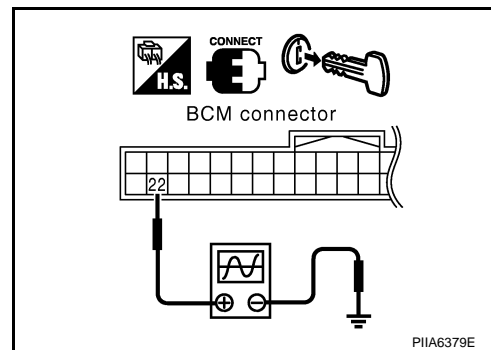

Is the inspection result normal?

- YES >> Door lock and unlock switch circuit is OK.
- NO >> GO TO 2

2.CHECK BCM OUTPUT SIGNAL

Check ("POWER WINDOW DOWN") in ACTIVE TEST mode for "MULTI REMOTE ENT" with CONSULT-III. Refer to [DLK-15, "DOOR LOCK : CONSULT-III Function \(BCM - DOOR LOCK\)"](#).

When "ACTIVE TEST" is performed, are the front windows lowered?

Is the inspection result normal?

- YES >> GO TO 3
- NO >> Replace BCM. Refer to [BCS-50, "Removal and Installation"](#).

3.CHECK DOOR LOCK/UNLOCK SWITCH GROUND HARNESS

1. Turn ignition switch OFF.
2. Disconnect main power window and door lock/unlock switch or power window and door lock/unlock switch RH.
3. Check continuity between main power window and door lock/unlock switch connector D8 terminal 17 and ground.

17 - Ground : Continuity should exist

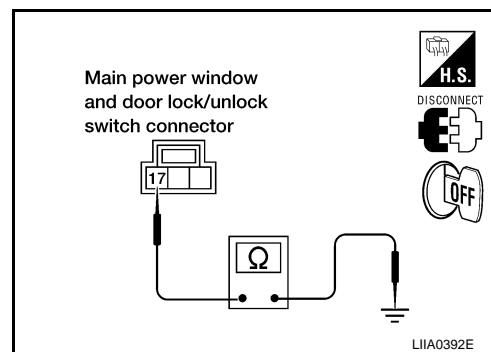

4. Check continuity between power window and door lock/unlock switch RH connector D105 terminal 11 and ground.

11 - Ground : Continuity should exist

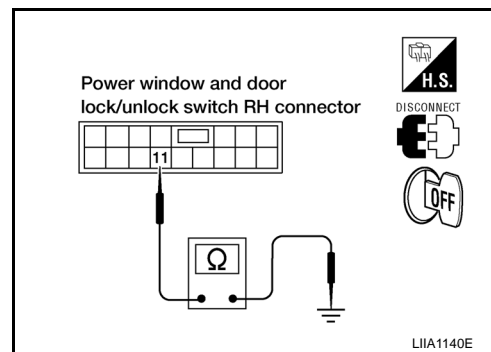

Is the inspection result normal?

- YES >> GO TO 4
- NO >> Repair or replace harness.

4.CHECK POWER WINDOW SERIAL LINK CIRCUIT

1. Disconnect BCM.
2. Check continuity between BCM connector M18 terminal 22 and main power window and door lock/unlock switch connector D7 terminal 14.

DOOR LOCK AND UNLOCK SWITCH

< COMPONENT DIAGNOSIS >

22 - 14

: Continuity should exist

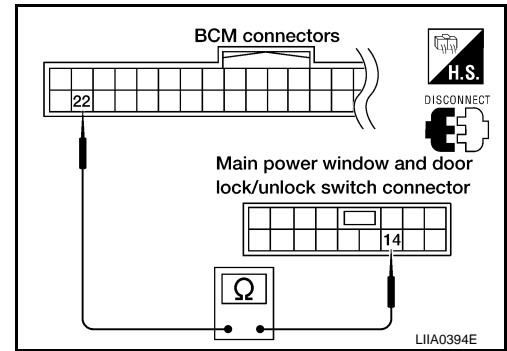

3. Check continuity between BCM connector M18 terminal 22 and power window and door lock/unlock switch RH connector D105 terminal 16.

22 - 16

: Continuity should exist

Is the inspection result normal?

- YES >> Replace main power window and door lock/unlock switch or power window and door lock/unlock switch RH.
NO >> Repair or replace harness.

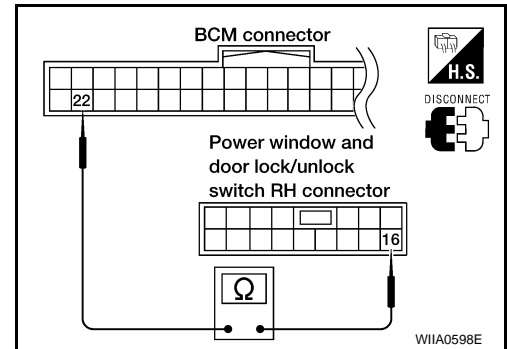

A
B
C
D
E
F
G
H
I
J
L
M
N
O
P

DLK

FRONT DOOR LOCK ASSEMBLY LH (KEY CYLINDER SWITCH)

< COMPONENT DIAGNOSIS >

FRONT DOOR LOCK ASSEMBLY LH (KEY CYLINDER SWITCH)

KING CAB

KING CAB : Description

INFOID:000000001546909

The main power window and door lock/unlock switch detects condition of the door key cylinder switch and transmits to BCM as the LOCK or UNLOCK signal.

KING CAB : Component Function Check

INFOID:000000001546910

1.CHECK DOOR KEY CYLINDER SWITCH INPUT SIGNAL

Check "KEY CYL LK-SW" AND "KEY CYL UN-SW" in DATA MONITOR mode for "POWER DOOR LOCK SYSTEM" with CONSULT-III.

Monitor item	Condition
KEY CYL LK-SW	Lock : ON
	Neutral / Unlock : OFF
KEY CYL UN-SW	Unlock : ON
	Neutral / Lock : OFF

Is the inspection result normal?

- YES >> Key cylinder switch is OK.
 NO >> Refer to [DLK-30. "KING CAB : Diagnosis Procedure"](#).

KING CAB : Diagnosis Procedure

INFOID:000000001572988

1.CHECK DOOR KEY CYLINDER SWITCH LH

④ With CONSULT-III

Check front door lock assembly LH (key cylinder switch) ("KEY CYL LK-SW") and ("KEY CYL UN-SW") in DATA MONITOR mode with CONSULT-III. Refer to [DLK-15. "DOOR LOCK : CONSULT-III Function \(BCM - DOOR LOCK\)"](#).

- When key inserted in front key cylinder is turned to LOCK:

KEY CYL LK-SW : ON

- When key inserted in front key cylinder is turned to UNLOCK:

KEY CYL UN-SW : ON

⊗ Without CONSULT-III

Check voltage between main power window and door lock/unlock switch connector D7 terminals 6, 7 and ground.

Connector	Terminals		Condition	Voltage (V) (Approx.)
	(+)	(-)		
D7	6	Ground	Neutral/Unlock	5
			Lock	0
	7		Neutral/Lock	5
			Unlock	0

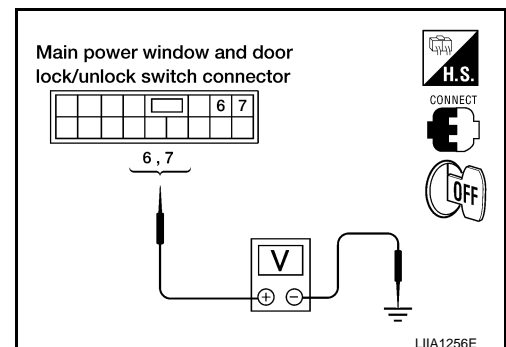

Is the inspection result normal?

- YES >> Front door lock assembly LH (key cylinder switch) signal is OK.

FRONT DOOR LOCK ASSEMBLY LH (KEY CYLINDER SWITCH)

< COMPONENT DIAGNOSIS >

NO >> GO TO 2

2. CHECK DOOR KEY CYLINDER SWITCH LH GROUND HARNESS

1. Turn ignition switch OFF.
2. Disconnect front door lock assembly LH (key cylinder switch).
3. Check continuity between front door lock assembly LH (key cylinder switch) connector (A) D14 terminal 5 and body ground.

Connector	Terminals	Continuity
D14	5 – Ground	Yes

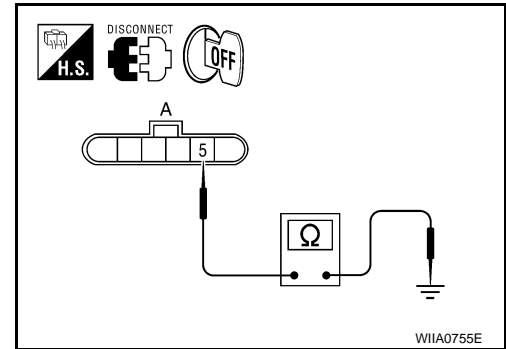

Is the inspection result normal?

YES >> GO TO 3

NO >> Repair or replace harness.

3. CHECK DOOR KEY CYLINDER SWITCH LH

Check continuity between front door lock assembly LH (key cylinder switch) terminals.

Terminals	Condition	Continuity
1 – 5	Key is turned to UNLOCK or neutral.	No
	Key is turned to LOCK.	Yes
5 – 6	Key is turned to LOCK or neutral.	No
	Key is turned to UNLOCK.	Yes

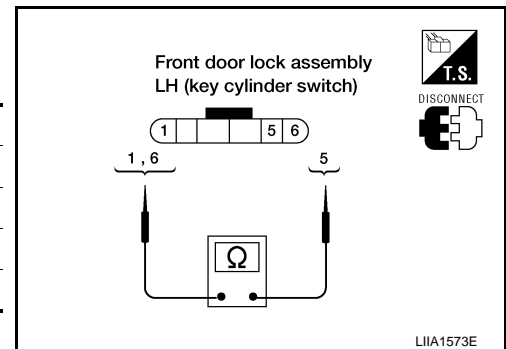

Is the inspection result normal?

YES >> GO TO 4

NO >> Replace front door lock assembly LH (key cylinder switch). Refer to [DLK-108. "Removal and Installation"](#).

4. CHECK DOOR KEY CYLINDER HARNESS

1. Disconnect main power window and door lock/unlock switch.
2. Check continuity between main power window and door lock/unlock switch connector (A) D7 terminals 6, 7 and front door lock assembly LH (key cylinder switch) connector (B) D14 terminals 1, 6 and body ground.

Connector	Terminals	Connector	Terminals	Continuity
A: Main power window and door lock/unlock switch	6	B: Front door lock assembly LH (key cylinder switch)	1	Yes
	7		6	Yes
	6, 7	Ground	No	

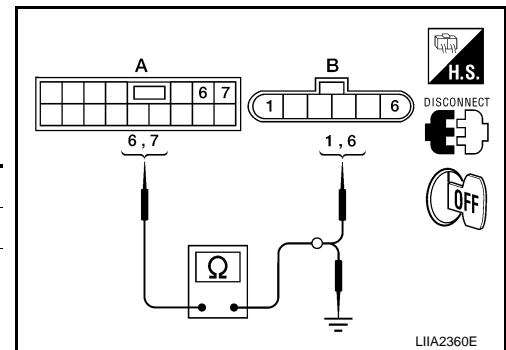

Is the inspection result normal?

YES >> Replace main power window and door lock/unlock switch.

NO >> Repair or replace harness.

CREW CAB

FRONT DOOR LOCK ASSEMBLY LH (KEY CYLINDER SWITCH)

< COMPONENT DIAGNOSIS >

CREW CAB : Description

INFOID:000000001572986

The main power window and door lock/unlock switch detects condition of the door key cylinder switch and transmits to BCM as the LOCK or UNLOCK signal.

CREW CAB : Component Function Check

INFOID:000000001572987

1.CHECK DOOR KEY CYLINDER SWITCH INPUT SIGNAL

Check "KEY CYL LK-SW" AND "KEY CYL UN-SW" in DATA MONITOR mode for "POWER DOOR LOCK SYSTEM" with CONSULT-III.

Monitor item	Condition
KEY CYL LK-SW	Lock : ON
	Neutral / Unlock : OFF
KEY CYL UN-SW	Unlock : ON
	Neutral / Lock : OFF

Is the inspection result normal?

- YES >> Key cylinder switch is OK.
 NO >> Refer to [DLK-32, "CREW CAB : Diagnosis Procedure"](#).

CREW CAB : Diagnosis Procedure

INFOID:000000001572989

1.CHECK DOOR KEY CYLINDER SWITCH LH

Ⓟ With CONSULT-II

Check front door lock assembly LH (key cylinder switch) ("KEY CYL LK-SW") and ("KEY CYL UN-SW") in DATA MONITOR mode with CONSULT-II. Refer to [DLK-15, "DOOR LOCK : CONSULT-III Function \(BCM - DOOR LOCK\)"](#).

- When key inserted in front key cylinder is turned to LOCK:

KEY CYL LK-SW : ON

- When key inserted in front key cylinder is turned to UNLOCK:

KEY CYL UN-SW : ON

ⓧ Without CONSULT-II

Check voltage between main power window and door lock/unlock switch connector D7 terminals 4, 6 and ground.

Connector	Terminals		Condition	Voltage (V) (Approx.)
	(+)	(-)		
D7	4	Ground	Neutral/Unlock	5
			Lock	0
	6		Neutral/Lock	5
			Unlock	0

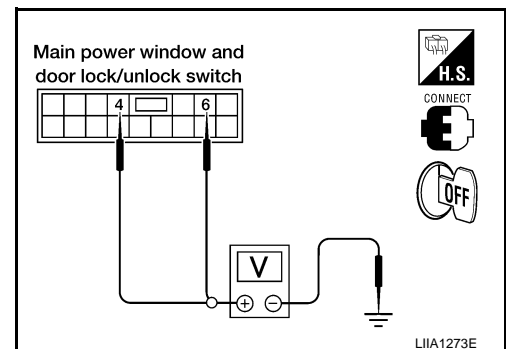

Is the inspection result normal?

- YES >> Front door lock assembly LH (key cylinder switch) signal is OK.
 NO >> GO TO 2

2.CHECK DOOR KEY CYLINDER SWITCH LH GROUND HARNESS

- Turn ignition switch OFF.

FRONT DOOR LOCK ASSEMBLY LH (KEY CYLINDER SWITCH)

< COMPONENT DIAGNOSIS >

- Disconnect front door lock assembly LH (key cylinder switch).
- Check continuity between front door lock assembly LH (key cylinder switch) connector (A) D14 terminal 5 and body ground.

Connector	Terminals	Continuity
D14	5 – Ground	Yes

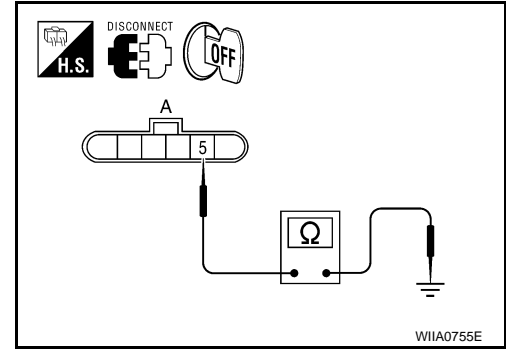

Is the inspection result normal?

- YES >> GO TO 3
 NO >> Repair or replace harness.

3. CHECK DOOR KEY CYLINDER SWITCH LH

Check continuity between front door lock assembly LH (key cylinder switch) terminals.

Terminals	Condition	Continuity
1 – 5	Key is turned to UNLOCK or neutral.	No
	Key is turned to LOCK.	Yes
5 – 6	Key is turned to LOCK or neutral.	No
	Key is turned to UNLOCK.	Yes

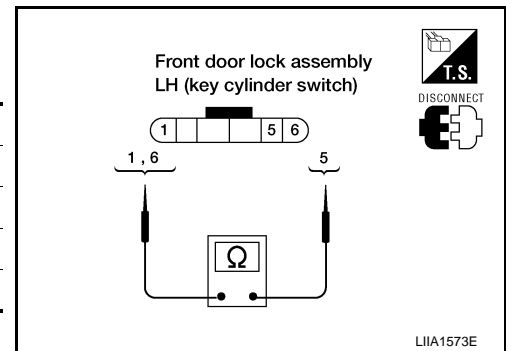

Is the inspection result normal?

- YES >> GO TO 4
 NO >> Replace front door lock assembly LH (key cylinder switch). Refer to [DLK-108. "Removal and Installation"](#).

4. CHECK DOOR KEY CYLINDER HARNESS

- Disconnect main power window and door lock/unlock switch.
- Check continuity between main power window and door lock/unlock switch connector (A) D7 terminals 4, 6 and front door lock assembly LH (key cylinder switch) connector (B) D14 terminals 1, 6 and body ground.

Connector	Terminals	Connector	Terminals	Continuity
A: Main power window and door lock/unlock switch	4	B: Front door lock assembly LH (key cylinder switch)	1	Yes
	6		6	Yes
	4, 6	Ground	No	

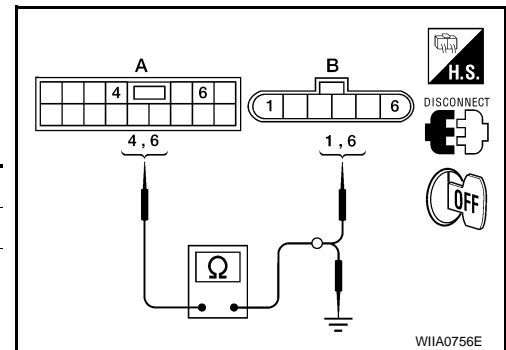

Is the inspection result normal?

- YES >> Replace main power window and door lock/unlock switch.
 NO >> Repair or replace harness.

A
B
C
D
E
F
G
H
I
J
DLK
L
M
N
O
P

KEY SWITCH (BCM INPUT)

< COMPONENT DIAGNOSIS >

KEY SWITCH (BCM INPUT) COLUMN SHIFT

COLUMN SHIFT : Diagnosis Procedure

INFOID:000000001572993

1. CHECK KEY SWITCH INPUT SIGNAL

 With CONSULT-III

Check key switch "KEY ON SW" in DATA MONITOR mode with CONSULT-III. Refer to [DLK-15. "DOOR LOCK : CONSULT-III Function \(BCM - DOOR LOCK\)"](#).

- When key is inserted to ignition key cylinder:

KEY ON SW :ON

- When key is removed from ignition key cylinder:

KEY ON SW :OFF

 Without CONSULT-III

Check voltage between BCM connector M18 terminal 37 and ground.

Connector	Terminals		Condition	Voltage (V)
	(+)	(-)		
M18	37	Ground	Key is inserted.	Battery voltage
			Key is removed.	0

Is the inspection result normal?

- YES >> Key switch (insert) circuit is OK.
NO >> GO TO 2

2. CHECK KEY SWITCH (INSERT)

- Turn ignition switch OFF.
- Disconnect key switch connector.
- Check continuity between key switch terminals 3 and 4.

Terminals	Condition	Continuity
3 - 4	Key is inserted.	Yes
	Key is removed.	No

Is the inspection result normal?

- YES >> GO TO 3
NO >> Replace key switch.

3. CHECK KEY SWITCH CIRCUIT

- Disconnect BCM connector.

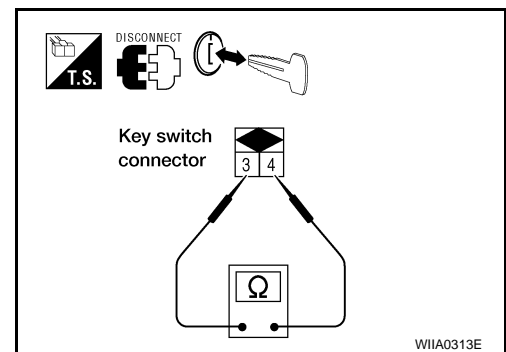
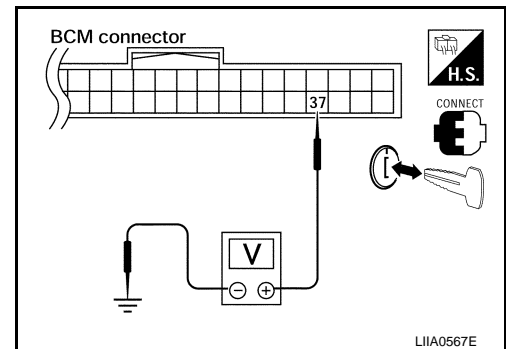

KEY SWITCH (BCM INPUT)

< COMPONENT DIAGNOSIS >

- Check continuity between the BCM harness connector M18 terminal 37 and key switch harness connector M80 terminal 4.
- Check continuity between BCM harness connector M18 terminal 37 (B/R) and ground.

37 - 4 : Continuity should exist
37 - Ground : Continuity should not exist

Is the inspection result normal?

YES >> Check the following:

- 10A fuse [No. 19, located in fuse block (J/B)]
- Harness for open or short between key switch and fuse

NO >> Repair or replace harness.

FLOOR SHIFT

FLOOR SHIFT : Diagnosis Procedure

INFOID:000000001572994

1.CHECK KEY SWITCH AND KEY LOCK SOLENOID INPUT SIGNAL

With CONSULT-III

Check key switch "KEY ON SW" in DATA MONITOR mode with CONSULT-III. Refer to [DLK-15. "DOOR LOCK : CONSULT-III Function \(BCM - DOOR LOCK\)"](#).

- When key is inserted to ignition key cylinder:

KEY ON SW :ON

- When key is removed from ignition key cylinder:

KEY ON SW :OFF

Without CONSULT-III

Check voltage between BCM connector M18 terminal 37 and ground.

Connector	Terminals		Condition	Voltage (V)
	(+)	(-)		
M18	37	Ground	Key is inserted.	Battery voltage
			Key is removed.	0

Is the inspection result normal?

YES >> Key switch (insert) circuit is OK.

NO >> GO TO 2

2.CHECK KEY SWITCH (INSERT)

- Turn ignition switch OFF.
- Disconnect key switch and key lock solenoid connector.
- Check continuity between key switch and key lock solenoid terminals 3 and 4.

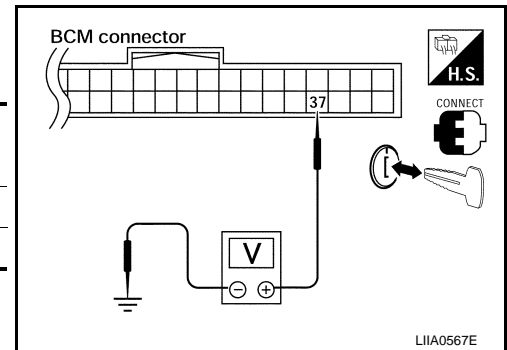
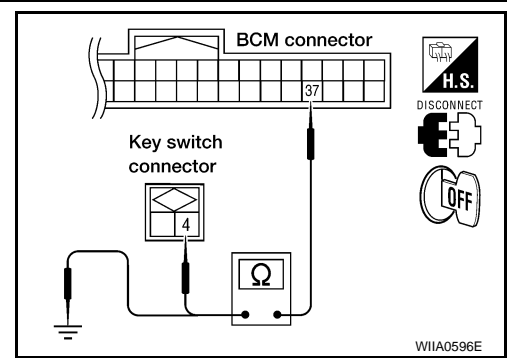

A
B
C
D
E
F
G
H
I
J
L
M
N
O
P

DLK

KEY SWITCH (BCM INPUT)

< COMPONENT DIAGNOSIS >

Terminals	Condition	Continuity
3 - 4	Key is inserted.	Yes
	Key is removed.	No

Is the inspection result normal?

YES >> GO TO 3

NO >> Replace key switch and key lock solenoid.

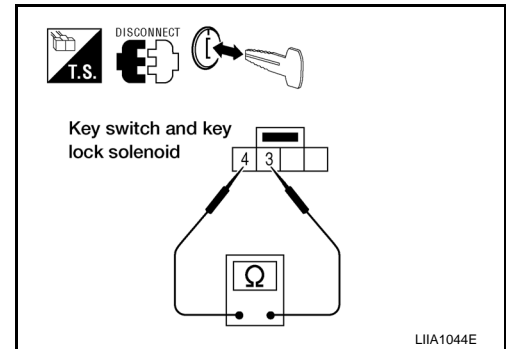

3. CHECK KEY SWITCH AND KEY LOCK SOLENOID CIRCUIT

1. Disconnect BCM connector.
2. Check continuity between the BCM harness connector M18 terminal 37 and key switch and key lock solenoid harness connector M27 terminal 4.
3. Check continuity between BCM harness connector M18 terminal 37 (B/R) and ground.

37 - 4 : Continuity should exist

37 - Ground : Continuity should not exist

Is the inspection result normal?

YES >> Check the following:

- 10A fuse [No. 19, located in fuse block (J/B)]
- Harness for open or short between key switch and key lock solenoid and fuse

NO >> Repair or replace harness.

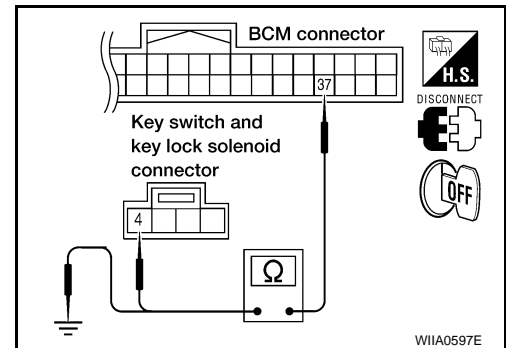

DOOR LOCK ACTUATOR

< COMPONENT DIAGNOSIS >

DOOR LOCK ACTUATOR FRONT LH

FRONT LH : Description

INFOID:000000001546912

Locks/unlocks the door with the signal from BCM.

FRONT LH : Component Function Check

INFOID:000000001546913

1. CHECK FUNCTION

1. Use CONSULT-III to perform Active Test "DOOR LOCK".
2. Touch "ALL LOCK" or "ALL UNLOCK" to check that it works normally.

Is the inspection result normal?

- YES >> Door lock actuator is OK.
NO >> Refer to [DLK-37, "FRONT LH : Diagnosis Procedure"](#).

FRONT LH : Diagnosis Procedure

INFOID:000000001572990

1. CHECK DOOR LOCK ACTUATOR SIGNAL

Check voltage between BCM connector M20 terminals 59, 65 and ground.

Connector	Terminals		Condition	Voltage (V) (Approx.)
	(+)	(-)		
M20	59	Ground	Driver door lock/unlock switch is turned to UNLOCK	0 → Battery voltage
	65		Driver door lock/unlock switch is turned to LOCK	0 → Battery voltage

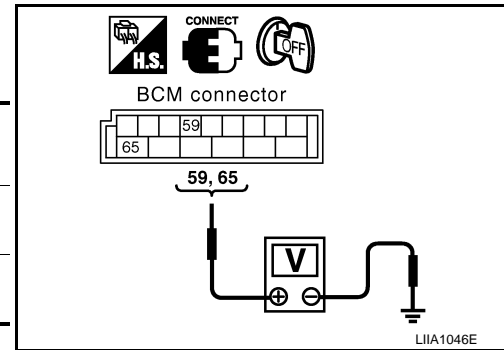

Is the inspection result normal?

- YES >> GO TO 2
NO >> Replace BCM. Refer to [BCS-50, "Removal and Installation"](#).

2. CHECK DOOR LOCK ACTUATOR HARNESS

1. Disconnect BCM and front door lock assembly LH.
2. Check continuity between BCM connector M20 terminals 59, 65 and front door lock assembly LH connector D14 terminals 2, 3.

Connector	Terminals	Connector	Terminals	Continuity
M20	59	D14	2	Yes
	65		3	Yes

3. Check continuity between BCM connector M20 terminals 59, 65 and ground.

Connector	Terminals	Continuity
M20	59	No
	65	No

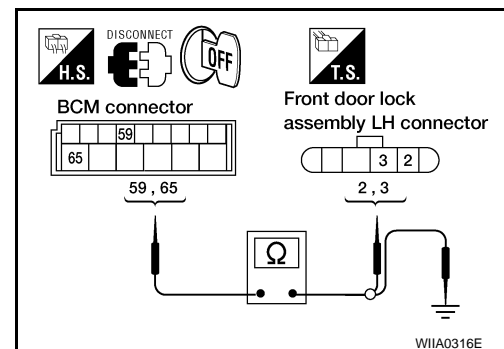

Is the inspection result normal?

- YES >> Replace front door lock assembly LH. Refer to [DLK-108, "Removal and Installation"](#).
NO >> Repair or replace harness.

FRONT RH

DOOR LOCK ACTUATOR

< COMPONENT DIAGNOSIS >

FRONT RH : Description

INFOID:000000001546915

Locks/unlocks the door with the signal from BCM.

FRONT RH : Component Function Check

INFOID:000000001546916

1.CHECK FUNCTION

1. Use CONSULT-III to perform Active Test DOOR LOCK.
2. Touch "ALL LOCK" or "ALL UNLOCK" to check that it works normally.

Is the inspection result normal?

- YES >> Door lock actuator is OK.
 NO >> Refer to [DLK-38. "FRONT RH : Diagnosis Procedure"](#).

FRONT RH : Diagnosis Procedure

INFOID:000000001572991

1.CHECK DOOR LOCK ACTUATOR SIGNAL

Check voltage between BCM connector M20 terminals 65, 66 and ground.

Connector	Terminals		Condition	Voltage (V) (Approx.)
	(+)	(-)		
M20	65	Ground	Door lock/unlock switch is turned to LOCK	0 → Battery voltage
	66		Door lock/unlock switch is turned to UNLOCK	0 → Battery voltage

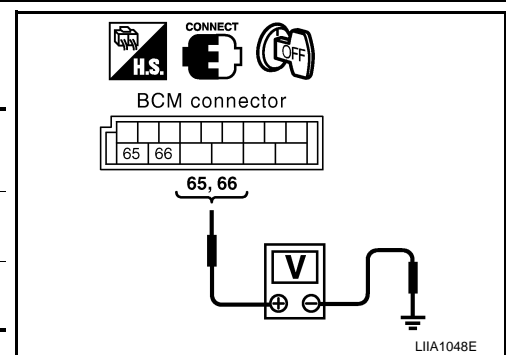

Is the inspection result normal?

- YES >> GO TO 2
 NO >> Replace BCM. Refer to [BCS-50. "Removal and Installation"](#).

2.CHECK DOOR LOCK ACTUATOR HARNESS

1. Disconnect BCM and door lock actuator RH.
2. Check continuity between BCM connector M20 terminals 65, 66 and front door lock actuator RH terminals 2, 3.

Terminals	Continuity
65 3	Yes
66 2	Yes

3. Check continuity between BCM connector M20 terminals 65, 66 and ground.

Terminals	Continuity
65 Ground	No
66 Ground	No

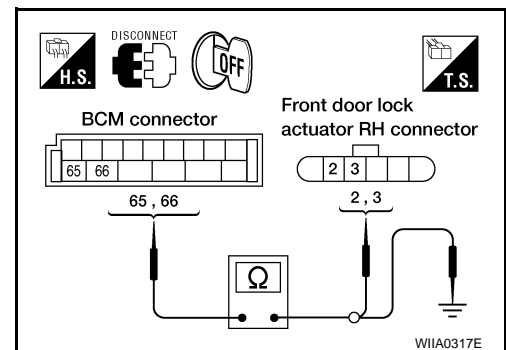

Is the inspection result normal?

- YES >> Replace front door lock actuator RH. Refer to [DLK-108. "Removal and Installation"](#).
 NO >> Repair or replace harness.

REAR RH/LH

REAR RH/LH : Description

INFOID:000000001546918

Locks/unlocks the door with the signal from BCM.

DOOR LOCK ACTUATOR

< COMPONENT DIAGNOSIS >

REAR RH/LH : Component Function Check

INFOID:000000001546919

1.CHECK FUNCTION

1. Use CONSULT-III to perform Active Test "DOOR LOCK".
2. Touch "ALL LOCK" or "ALL UNLOCK" to check that it works normally.

Is the inspection result normal?

- YES >> Door lock actuator is OK.
 NO >> Refer to [DLK-39. "REAR RH/LH : Diagnosis Procedure"](#).

REAR RH/LH : Diagnosis Procedure

INFOID:000000001572992

1.CHECK DOOR LOCK ACTUATOR SIGNAL

Check voltage between BCM connector M20 terminals 65, 66 and ground.

Connector	Terminals		Condition	Voltage (V) (Approx.)
	(+)	(-)		
M20	65	Ground	Door lock/unlock switch is turned to LOCK	0 → Battery voltage
	66		Door lock/unlock switch is turned to UNLOCK	0 → Battery voltage

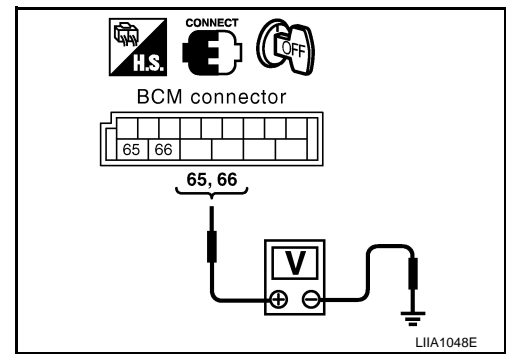

Is the inspection result normal?

- YES >> GO TO 2
 NO >> Replace BCM. Refer to [BCS-50. "Removal and Installation"](#).

2.CHECK DOOR LOCK ACTUATOR HARNESS

1. Disconnect BCM and inoperative door lock actuator.
2. Check continuity between BCM connector M20 terminals 65, 66 and rear door lock actuator connector terminals 2, 3.

Terminals	Continuity
65 3	Yes
66 2	Yes

3. Check continuity between BCM connector M20 terminals 65, 66 and ground.

Terminals	Continuity
65 Ground	No
66 Ground	No

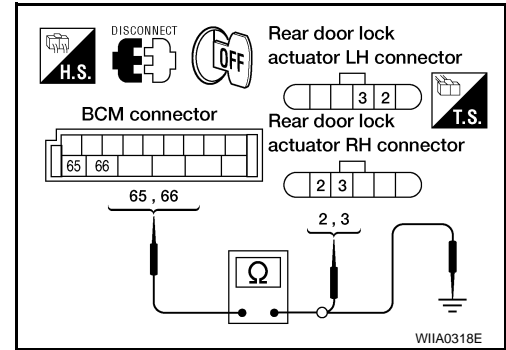

Is the inspection result normal?

- YES >> Replace door lock actuator. Refer to [DLK-112. "Removal and Installation"](#).
 NO >> Repair or replace harness.

A
B
C
D
E
F
G
H
I
J
L
M
N
O
P

DLK

REMOTE KEYLESS ENTRY RECEIVER

< COMPONENT DIAGNOSIS >

REMOTE KEYLESS ENTRY RECEIVER

Description

INFOID:000000001546928

Receives keyfob operation and transmits to BCM.

Component Function Check

INFOID:000000001546929

1.CHECK FUNCTION

With CONSULT-III

Check remote keyless entry receiver "RKE OPE COUN1" in Data Monitor mode with CONSULT-III.

Monitor item	Condition
RKE OPE COUN1	Checks whether value changes when operating the keyfob.

Is the inspection result normal?

- YES >> Remote keyless entry receiver is OK.
- NO >> Refer to [DLK-40, "Diagnosis Procedure"](#).

Diagnosis Procedure

INFOID:000000001546930

1.CHECK REMOTE KEYLESS ENTRY RECEIVER OUTPUT SIGNAL

1. Turn ignition switch OFF.
2. Check remote keyless entry receiver signal with an oscilloscope.

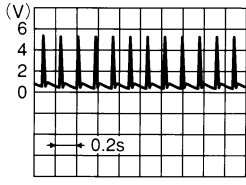
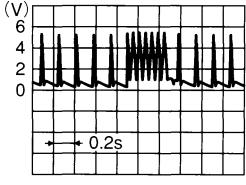
Terminals		Keyfob condition	Signal (Reference value)
(+)	(-)		
Remote keyless entry receiver connector	Terminal		
M120	2	Ground	 <p>OCC3879D</p>
		Any button is pressed	 <p>OCC3880D</p>

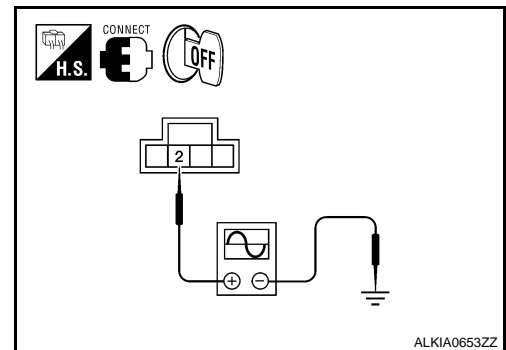

Is the inspection result normal?

- YES >> GO TO 2
- NO >> GO TO 4

2.REMOTE KEYLESS ENTRY RECEIVER 5-VOLT CIRCUIT INSPECTION

REMOTE KEYLESS ENTRY RECEIVER

< COMPONENT DIAGNOSIS >

Check voltage between remote keyless entry receiver connector M120 terminal 4 and ground.

4 - Ground : Approx. 5 volt.

Is the inspection result normal?

- YES >> GO TO 3
- NO >> GO TO 4

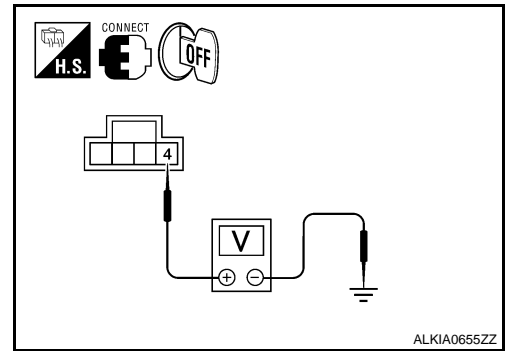

3. REMOTE KEYLESS ENTRY RECEIVER GROUND CIRCUIT INSPECTION

Check continuity between remote keyless entry receiver connector M120 terminal 1 and ground.

1 - Ground : Continuity should exist.

Is the inspection result normal?

- YES >> Replace remote keyless entry receiver.
- NO >> GO TO 4

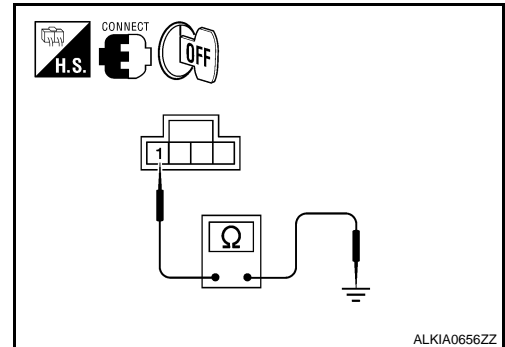

4. HARNESS INSPECTION BETWEEN INTELLIGENT KEY UNIT AND RKE RECEIVER

1. Disconnect remote keyless entry receiver and BCM connectors.
2. Check continuity between BCM connector M18 terminals 18, 19, 20 and remote keyless entry receiver connector M120 terminals 1, 2, 4.

1 - 18 : Continuity should exist.
2 - 20 : Continuity should exist.
4 - 19 : Continuity should exist.

3. Check continuity between remote keyless entry receiver connector M120 terminals 1, 2, 4 and ground.

1 - Ground : Continuity should not exist.
2 - Ground : Continuity should not exist.
4 - Ground : Continuity should not exist.

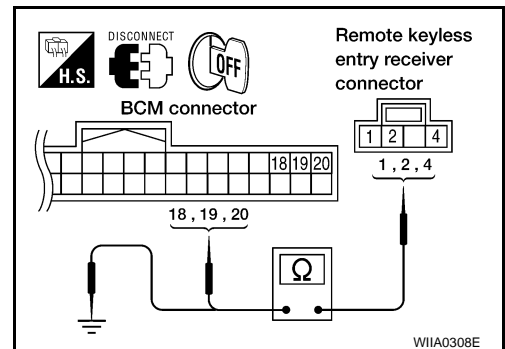

Is the inspection result normal?

- YES >> Replace remote keyless entry receiver.
- NO >> Repair or replace the harness between the remote keyless entry receiver and BCM.

A
B
C
D
E
F
G
H
I
J
DLK
L
M
N
O
P

KEYFOB BATTERY AND FUNCTION

< COMPONENT DIAGNOSIS >

KEYFOB BATTERY AND FUNCTION

Description

INFOID:000000001546931

The following functions are available when having and carrying electronic ID.

- Door lock/unlock
- Back door open

Remote control entry function and panic alarm function are available when operating the remote buttons.

Component Function Check

INFOID:000000001546932

1. CHECK FUNCTION

④ With CONSULT-III

Check remote keyless entry receiver "RKE OPE COUN1" in Data Monitor mode with CONSULT-III.

Monitor item	Condition
RKE OPE COUN1	Check that the numerical value is changing while operating the keyfob.

Is the inspection result normal?

YES >> Keyfob is OK.

NO >> Refer to [DLK-42, "Diagnosis Procedure"](#).

Diagnosis Procedure

INFOID:000000001546933

1. CHECK KEYFOB BATTERY

Check by connecting a resistance (approximately 300Ω) so that the current value becomes about 10 mA.

Standard : Approx. 2.5 - 3.0V

Is the measurement value within specification?

YES >> GO TO 2

NO >> Replace Keyfob battery.

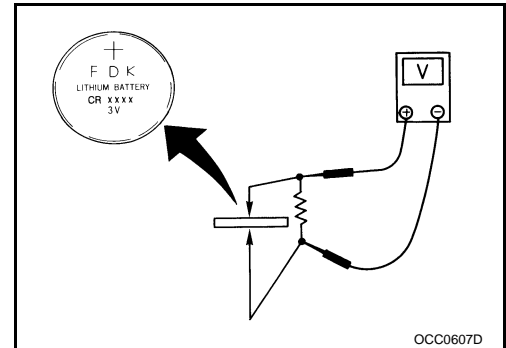

2. CHECK KEYFOB FUNCTION

Check keyfob function using Remote Keyless Entry Tester J-43241.

Does the test pass?

YES >> Keyfob is OK.

NO >> Replace keyfob. Refer to CONSULT-III Operation Manual.

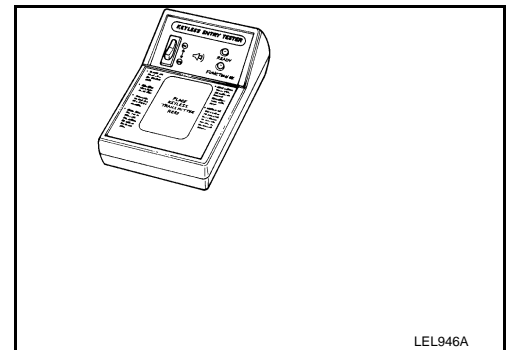

Component Inspection

INFOID:000000001546934

1. REPLACE INTELLIGENT KEY BATTERY

KEYFOB BATTERY AND FUNCTION

< COMPONENT DIAGNOSIS >

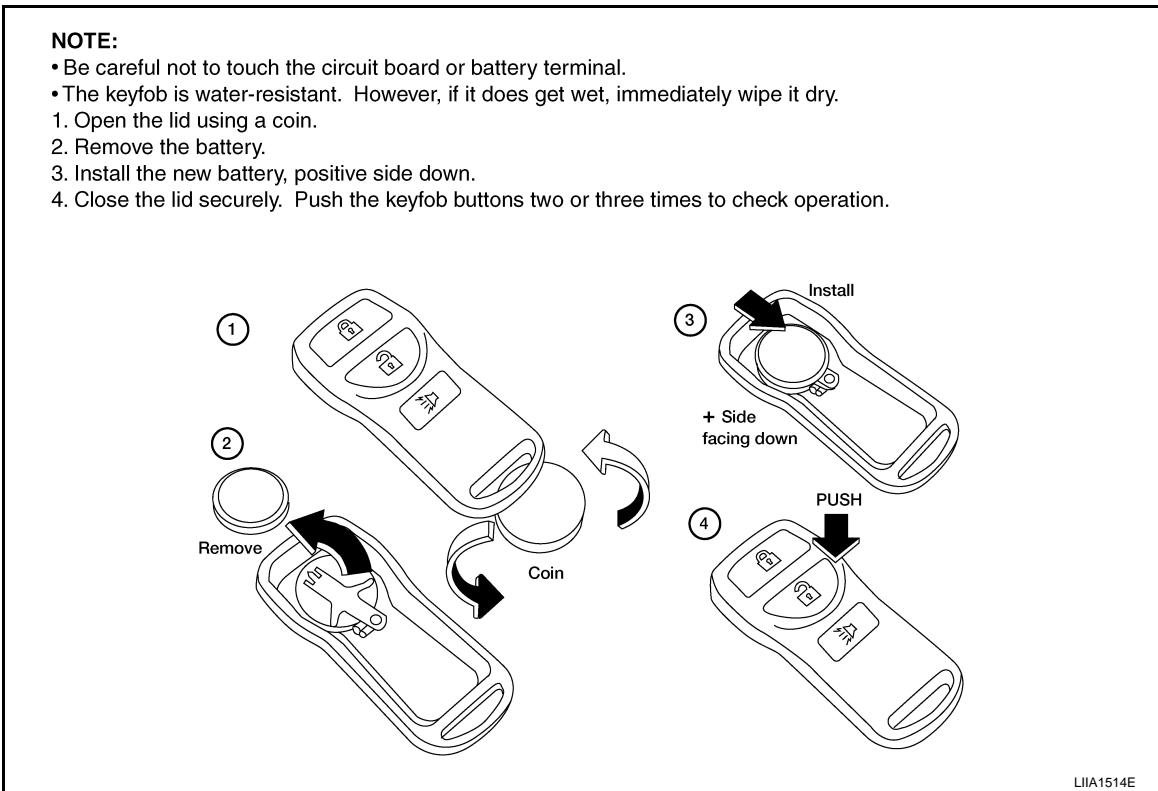

Check keyfob operation after replacing the battery.

Is the inspection result normal?

YES >> Keyfob is OK.

NO >> Check remote keyless entry receiver. Refer to [DLK-40. "Component Function Check"](#).

Special Repair Requirement

INFOID:000000001546935

Refer to CONSULT-III Operation Manual.

A
B
C
D
E
F
G
H
I
J
L
M
N
O
P

DLK

HORN FUNCTION

< COMPONENT DIAGNOSIS >

HORN FUNCTION

Description

INFOID:000000001546936

Perform answer-back for each operation with horn.

Component Function Check

INFOID:000000001546937

1.CHECK FUNCTION

1. Select "HORN" in "ACTIVE TEST" mode with CONSULT-III.
2. Check the horn (high/low) operation.

Test item		Description	
HORN	ON	Horn relay	ON (for 20 ms)

Is the operation normal?

- YES >> INSPECTION END.
 NO >> Go to [DLK-44, "Diagnosis Procedure"](#).

Diagnosis Procedure

INFOID:000000001546938

1.CHECK HORN FUNCTION

Check horn function with horn switch

Do the horns sound?

- YES >> GO TO 2
 NO >> Go to [HRN-3, "Wiring Diagram"](#).

2.CHECK HORN RELAY POWER SUPPLY

1. Turn ignition switch ON.
2. Perform "ACTIVE TEST", "HORN" with CONSULT-III.
3. Using an oscilloscope or analog voltmeter, check voltage between horn relay harness connector and ground.

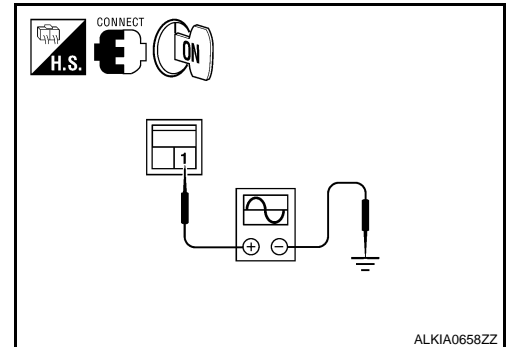

Horn relay		Ground	Test item	Voltage (V) (Approx.)
Connector	Terminal			
H-1	1	Ground	HORN	Battery voltage → 0 → Battery voltage
			Other than above	Battery voltage

Is the inspection result normal?

- YES >> GO TO 4
 NO >> GO TO 3

3.CHECK HORN RELAY CIRCUIT

1. Turn ignition switch OFF.
2. Disconnect IPDM E/R and horn relay connector.

HORN FUNCTION

< COMPONENT DIAGNOSIS >

3. Check continuity between IPDM E/R harness connector and horn relay harness connector.

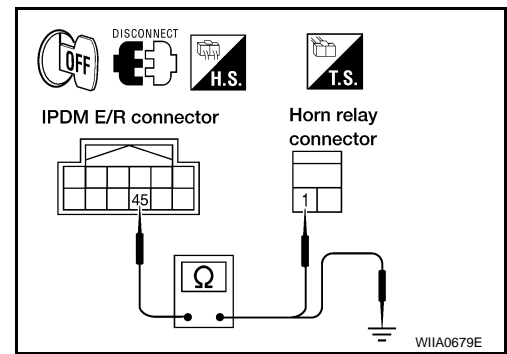

IPDM E/R		Horn relay		Continuity
Connector	Terminal	Connector	Terminal	
E122	45	H-1	1	Yes

4. Check continuity between IPDM E/R harness connector and ground.

IPDM E/R		Ground	Continuity
Connector	Terminal		
E122	45	Ground	No

Is the inspection result normal?

YES >> GO TO 4

NO >> Repair or replace harness.

4.CHECK INTERMITTENT INCIDENT

Refer to [GI-41. "Intermittent Incident"](#).

Is the inspection result normal?

YES >> Replace IPDM E/R. Refer to [PCS-30. "Removal and Installation of IPDM E/R"](#).

NO >> Repair or replace the malfunctioning part.

A
B
C
D
E
F
G
H
I
J
L
M
N
O
P

DLK

WARNING CHIME FUNCTION

< COMPONENT DIAGNOSIS >

WARNING CHIME FUNCTION

Description

INFOID:000000001546939

Performs operation method guide and warning with buzzer.

Component Function Check

INFOID:000000001546940

1. CHECK FUNCTION

With CONSULT-III

1. Turn ignition switch ON.
2. Using Consult-III, check the operation of the inside chime by performing "INSIDE BUZZER" ACTIVE TEST.

Does the inside chime operate normally?

- YES >> Warning buzzer into combination meter is OK.
NO >> Refer to [DLK-46, "Diagnosis Procedure"](#).

Diagnosis Procedure

INFOID:000000001546941

1. CHECK METER BUZZER CIRCUIT

The inoperative warning chime is contained inside the combination meter. Replace combination meter. Refer to [MWI-72, "Removal and Installation"](#).

>> Inspection end.

HAZARD FUNCTION

< COMPONENT DIAGNOSIS >

HAZARD FUNCTION

Description

INFOID:000000001546942

Perform answer-back for each operation with number of blinks.

Component Function Check

INFOID:000000001546943

1.CHECK FUNCTION

Check hazard warning lamp "FLASHER" in ACTIVE TEST.

Is the inspection result normal?

YES >> Hazard warning lamp circuit is OK.

NO >> Refer to [DLK-47, "Diagnosis Procedure"](#).

Diagnosis Procedure

INFOID:000000001546944

1.CHECK HAZARD SWITCH CIRCUIT

Operate the hazard lights by turning ON the hazard warning switch.

Do the lights operate normally?

YES >> Replace the BCM. Refer to [BCS-50, "Removal and Installation"](#).

NO >> Repair or replace hazard warning switch circuit. Refer to [EXL-3, "Work Flow"](#).

A
B
C
D
E
F
G
H
I
J
L
M
N
O
P

DLK

HEADLAMP FUNCTION

< COMPONENT DIAGNOSIS >

HEADLAMP FUNCTION

Diagnosis Procedure

INFOID:000000001546946

1. CHECK HEADLAMP OPERATION

Do headlamps operate with headlamp switch?

YES or NO

YES >> Headlamp circuit is OK.

NO >> Check headlamp circuit. Refer to [EXL-3, "Work Flow"](#).

MAP LAMP AND IGNITION KEYHOLE ILLUMINATION FUNCTION

< COMPONENT DIAGNOSIS >

MAP LAMP AND IGNITION KEYHOLE ILLUMINATION FUNCTION

Diagnosis Procedure

INFOID:000000001546947

1. CHECK MAP LAMP OPERATION

When room lamp switch is in "DOOR" position, open the driver or passenger door.
Map lamp and ignition keyhole illumination should illuminate.

Is the inspection result normal?

YES >> Map lamp circuit is OK.

NO >> Check map lamp circuit. Refer to [INL-3. "Work Flow"](#).

A
B
C
D
E
F
G
H
I
J
L
M
N
O
P

DLK

KEYFOB ID SET UP WITH CONSULT-III

< COMPONENT DIAGNOSIS >

KEYFOB ID SET UP WITH CONSULT-III

ID Code Entry Procedure

INFOID:000000001546948

KEYFOB ID SET UP WITH CONSULT-III

NOTE:

- If a keyfob is lost, the ID code of the lost keyfob must be erased to prevent unauthorized use. A specific ID code can be erased with CONSULT-III. However, when the ID code of a lost keyfob is not known, all controller ID codes should be erased. After all ID codes are erased, the ID codes of all remaining and/or new keyfobs must be re-registered.
- When registering an additional keyfob, the existing ID codes in memory may or may not be erased. If five ID codes are stored in memory when an additional code is registered, only the oldest code is erased. If less than five codes are stored in memory when an additional code is registered, the new ID code is added and no ID codes are erased.
- Entry of a maximum of five ID codes is allowed. When more than five codes are entered, the oldest ID code will be erased.
- Even if the same ID code that is already in memory is input, the same ID code can be entered. The code is counted as an additional code.

1. Turn ignition switch ON.
2. Select "BCM".
3. Select "MULTI REMOTE ENT".
4. Select "WORK SUPPORT".
5. You can register, erase or confirm a keyfob ID code. To register a new code, select the following option and follow CONSULT-III instructions:
 - "REMO CONT ID REGIST"
Use this mode to register a keyfob ID code.

NOTE:

Register the ID code when keyfob or BCM is replaced, or when additional keyfob is required.

- "REMO CONT ID ERASUR"
Use this mode to erase a keyfob ID code.
- "REMO CONT ID CONFIR"
Use this mode to confirm if a keyfob ID code is registered or not.

KEYFOB ID SET UP WITHOUT CONSULT-III

< COMPONENT DIAGNOSIS >

KEYFOB ID SET UP WITHOUT CONSULT-III

ID Code Entry Procedure

INFOID:000000001546949

KEYFOB ID SET UP WITHOUT CONSULT-III

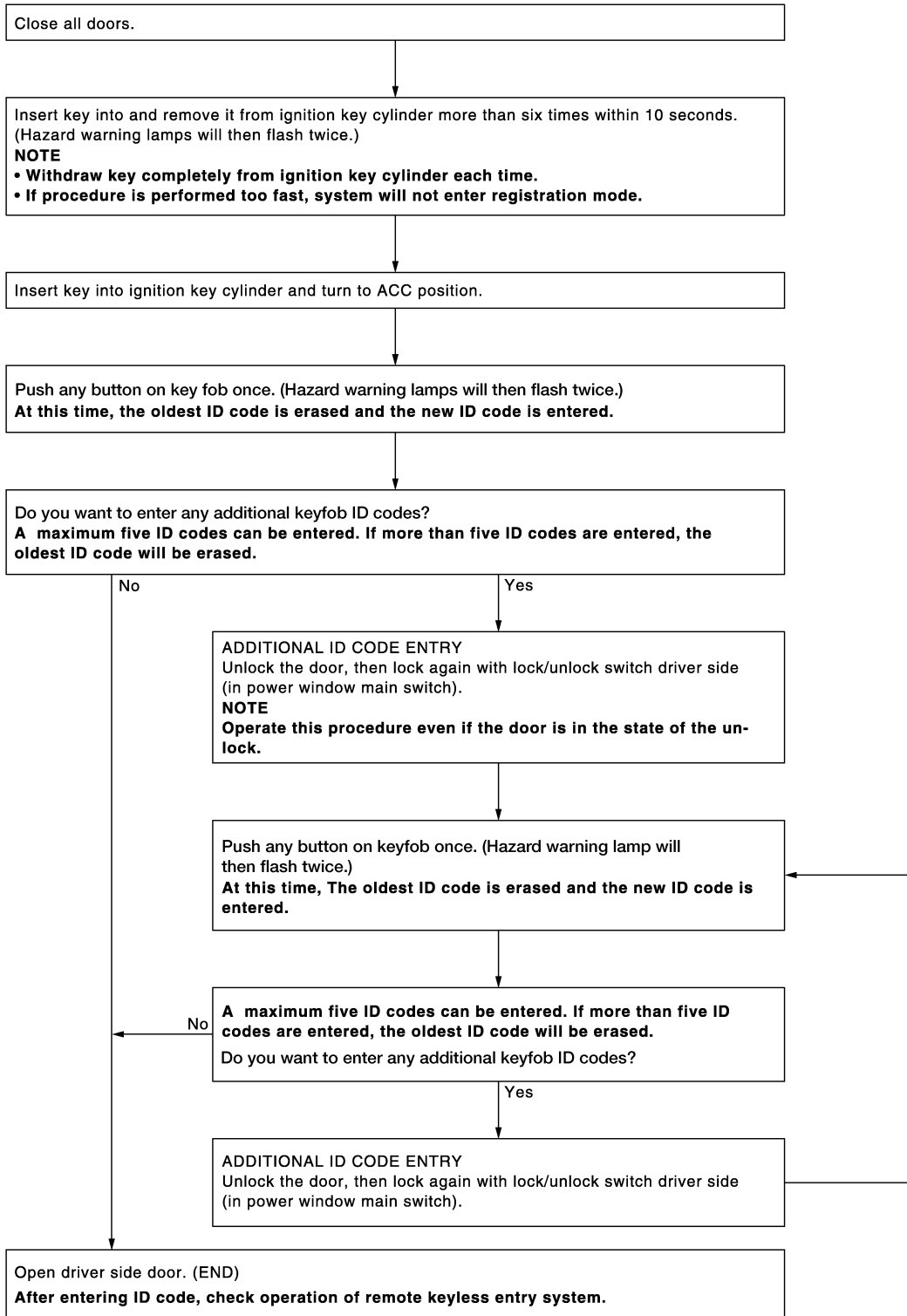

NOTE:

- If a keyfob is lost, the ID code of the lost keyfob must be erased to prevent unauthorized use. A specific ID code can be erased with CONSULT-III. However, when the ID code of a lost keyfob is not known, all control-

LIA1670E

A
B
C
D
E
F
G
H
I
J
L
M
N
O
P

DLK

KEYFOB ID SET UP WITHOUT CONSULT-III

< COMPONENT DIAGNOSIS >

ler ID codes should be erased. After all ID codes are erased, the ID codes of all remaining and/or new keyfobs must be re-registered.

To erase all ID codes in memory, register one ID code (keyfob) five times. After all ID codes are erased, the ID codes of all remaining and/or new keyfobs must be re-registered.

- When registering an additional keyfob, the existing ID codes in memory may or may not be erased. If five ID codes are stored in memory, when an additional code is registered, only the oldest code is erased. If less than five ID codes are stored in memory, when an additional ID code is registered, the new ID code is added and no ID codes are erased.
- If you need to activate more than two additional new keyfobs, repeat the procedure “Additional ID code entry” for each new keyfob.
- Entry of maximum five ID codes is allowed. When more than five ID codes are entered, the oldest ID code will be erased.
- Even if same ID code that is already in the memory is input, the same ID code can be entered. The code is counted as an additional code.

HOMELINK UNIVERSAL TRANSCEIVER

< COMPONENT DIAGNOSIS >

HOMELINK UNIVERSAL TRANSCEIVER

Description

INFOID:000000001546962

Homelink universal transceiver can store and transmit a maximum of 3 radio signals. Allows operation of garage doors, gates, home and office lighting, entry door locks and security system, etc. Homelink universal transceiver power supply uses vehicle battery, which enables it to maintain every program in case battery is discharged or removed.

Component Function Check

INFOID:000000001546963

1.CHECK FUNCTION

Check that system receiver (garage door opener, etc.) operates with original hand-held transmitter.

Is the inspection result normal?

- YES >> GO TO 2
- NO >> Receiver or hand-held transmitter is malfunctioning.

2.CHECK ILLUMINATION

1. Turn ignition switch "OFF".
2. Press each of the transmitter buttons and watch for the red light to illuminate with each button.

Is the inspection result normal?

- YES >> GO TO 3
- NO >> Refer to [DLK-53, "Diagnosis Procedure"](#).

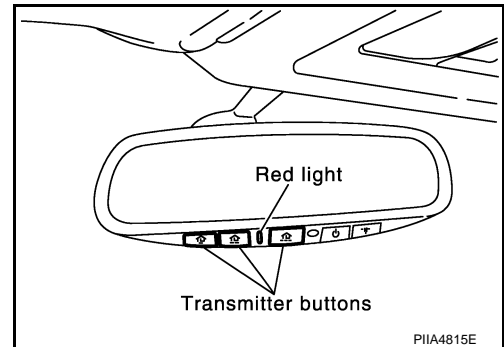

3.CHECK TRANSMITTER

Check transmitter with Tool*.

*:For details, refer to Technical Service Bulletin.

Is the inspection result normal?

- YES >> Receiver or hand-held transmitter malfunction, not vehicle related.
- NO >> Replace auto anti-dazzling inside mirror (homelink universal transceiver).

Diagnosis Procedure

INFOID:000000001546964

1.CHECK POWER SUPPLY

1. Disconnect auto anti-dazzling inside mirror (homelink universal transceiver) connector.
2. Check voltage between auto anti-dazzling inside mirror (homelink universal transceiver) harness connector and ground.

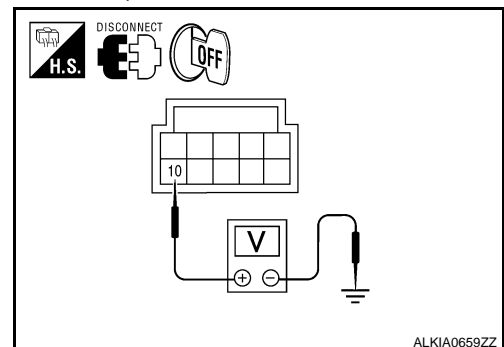

HOMELINK UNIVERSAL TRANSCEIVER

< COMPONENT DIAGNOSIS >

Auto anti-dazzling inside mirror (Homelink universal transceiver) connector	Terminal		Condition	Voltage (V) (Approx.)
R4	10	Ground	Ignition switch position: LOCK	Battery voltage

Is the inspection result normal?

YES >> GO TO 2

NO >> Check the following.

- 10A fuse [No. 19 located in the fuse block (J/B)]
- Harness for open or short between fuse and auto anti-dazzling inside mirror (homelink universal transceiver).

2.CHECK GROUND CIRCUIT

Check continuity between auto anti-dazzling inside mirror (homelink universal transceiver) harness connector and ground.

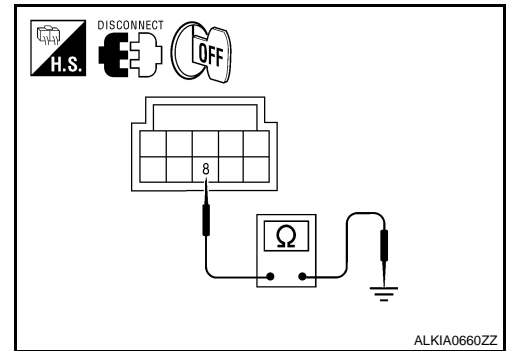

Auto anti-dazzling inside mirror (Homelink universal transceiver) connector	Terminal	Ground	Continuity
R4	8		Yes

Is the inspection result normal?

YES >> GO TO 3

NO >> Repair harness.

3.CHECK INTERMITTENT INCIDENT

Refer to [GI-41, "Intermittent Incident"](#).

>> INSPECTION END.

BCM (BODY CONTROL MODULE)

< ECU DIAGNOSIS >

ECU DIAGNOSIS

BCM (BODY CONTROL MODULE)

Reference Value

INFOID:000000001546965

VALUES ON THE DIAGNOSIS TOOL

Refer to [BCS-35, "Reference Value"](#).

TERMINAL LAYOUT

Refer to [BCS-37, "Terminal Layout"](#).

A

B

C

D

E

F

G

H

I

J

DLK

L

M

N

O

P

BCM (BODY CONTROL MODULE)

< ECU DIAGNOSIS >

Wiring Diagram—POWER DOOR LOCK SYSTEM (KING CAB)—

INFOID:000000001546966

POWER DOOR LOCK - KING CAB

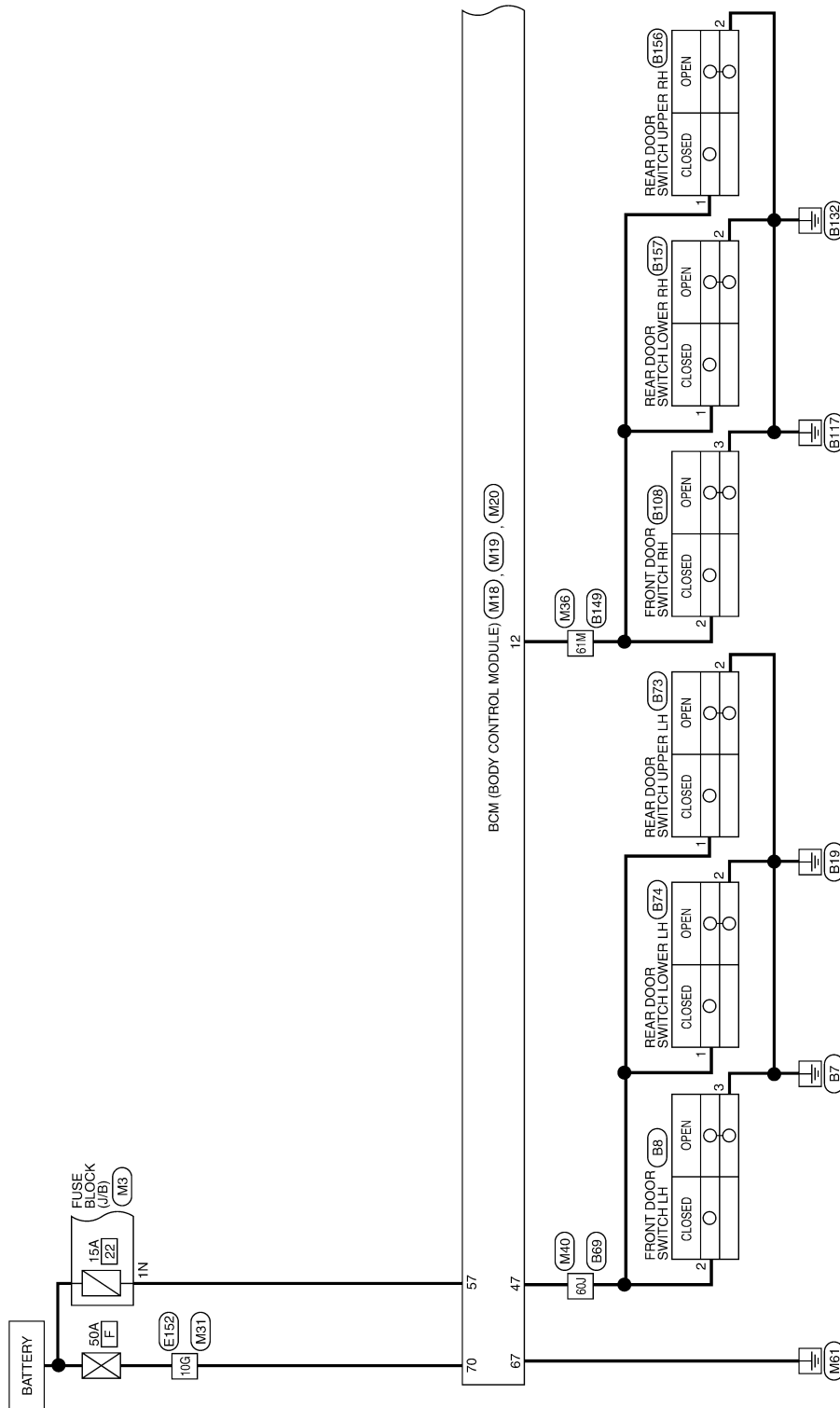

ALKWA0164GE

BCM (BODY CONTROL MODULE)

< ECU DIAGNOSIS >

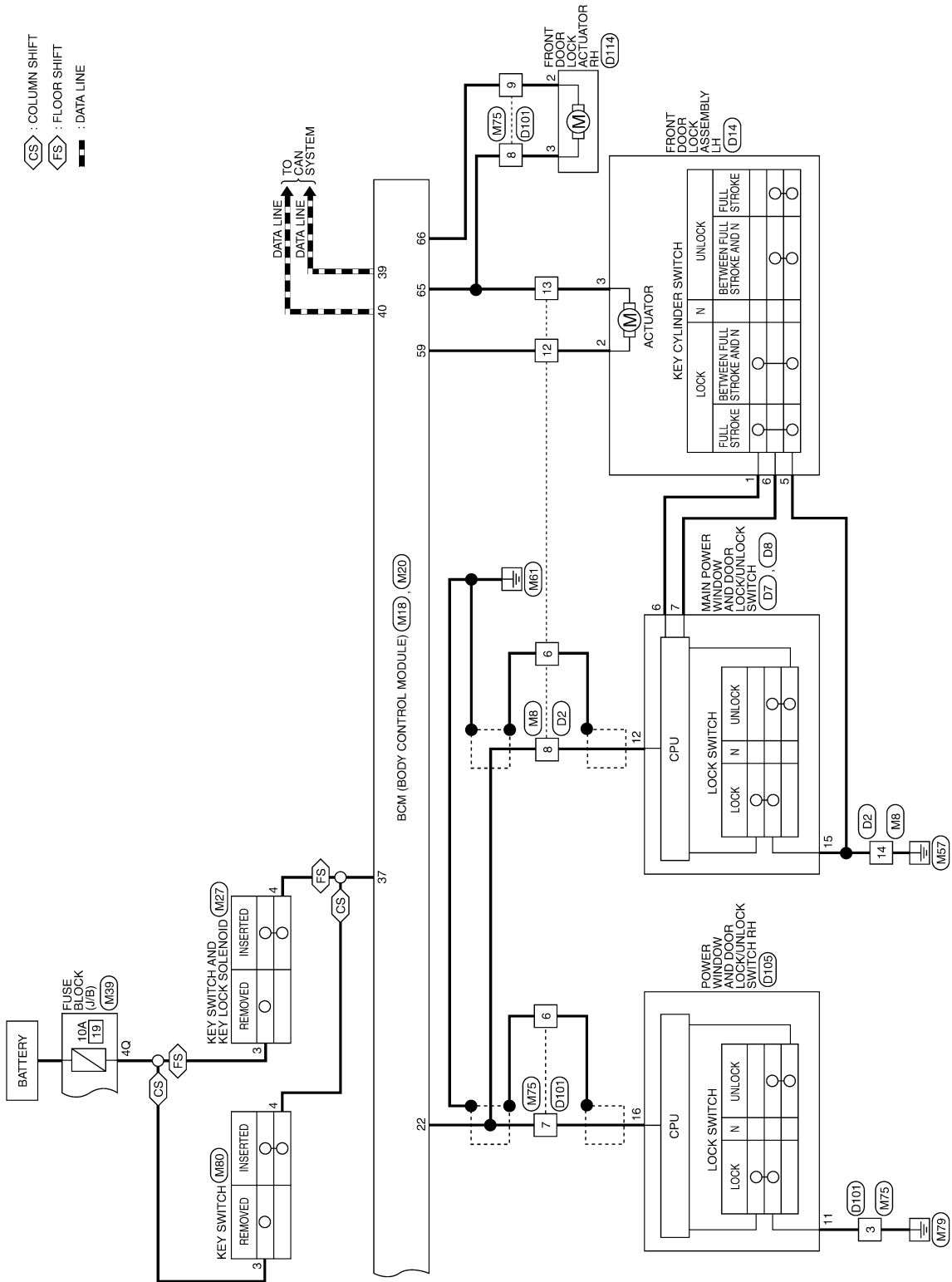

ALKWA0165GE

A
B
C
D
E
F
G
H
I
J
K
L
M
N
O
P

DLK

BCM (BODY CONTROL MODULE)

< ECU DIAGNOSIS >

POWER DOOR LOCK - KING CAB CONNECTORS

Connector No.	M3
Connector Name	FUSE BLOCK (J/B)
Connector Color	WHITE

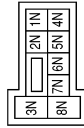

Terminal No.	Color of Wire	Signal Name
1N	Y/R	-

Connector No.	M8
Connector Name	WIRE TO WIRE
Connector Color	WHITE

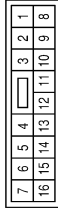

Terminal No.	Color of Wire	Signal Name
6	SHIELD	-
8	G	-
12	G	-
13	V	-
14	B	-

Connector No.	M18
Connector Name	BCM (BODY CONTROL MODULE)
Connector Color	WHITE

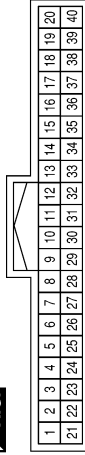

Terminal No.	Color of Wire	Signal Name
12	R/L	DOOR SW (AS)
13	GR	DOOR SW (RR)
22	G	ANTI-PINCH SERIAL LINK (RX, TX)
37	B/R	KEY_SW
39	L	CAN-H
40	P	CAN-L

Connector No.	M19
Connector Name	BCM (BODY CONTROL MODULE)
Connector Color	WHITE

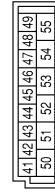

Terminal No.	Color of Wire	Signal Name
47	SB	DOOR SW (DR)
48	R/Y	DOOR SW (RL)

Connector No.	M20
Connector Name	BCM (BODY CONTROL MODULE)
Connector Color	BLACK



Terminal No.	Color of Wire	Signal Name
57	Y/R	B+ (ALL INT LIGHTS)
59	G	DL UNLOCK DR
65	V	DL LOCK ALL

Terminal No.	Color of Wire	Signal Name
66	G/Y	DL UNLOCK ALL
67	B	GND (POWER)
70	W/B	BATT (F/L)

BCM (BODY CONTROL MODULE)

< ECU DIAGNOSIS >

Connector No.	M27
Connector Name	KEY SWITCH AND KEY LOCK SOLENOID
Connector Color	WHITE

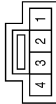

Terminal No.	Color of Wire	Signal Name
3	Y/R	-
4	B/R	-

Connector No.	M31
Connector Name	WIRE TO WIRE
Connector Color	WHITE

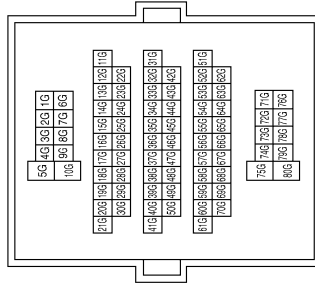

Terminal No.	Color of Wire	Signal Name
10G	W/B	-

Connector No.	M36
Connector Name	WIRE TO WIRE
Connector Color	WHITE

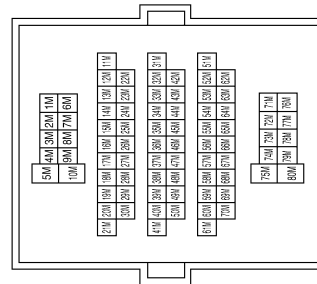

Terminal No.	Color of Wire	Signal Name
6M	G/Y	-
56M	GR	-
61M	R/L	-
74M	V	-

Connector No.	M39
Connector Name	FUSE BLOCK (J/B)
Connector Color	WHITE



Terminal No.	Color of Wire	Signal Name
4Q	Y/R	-

ALKIA1078GB

A
B
C
D
E
F
G
H
I
J
DLK
L
M
N
O
P

BCM (BODY CONTROL MODULE)

< ECU DIAGNOSIS >

Connector No.	M40
Connector Name	WIRE TO WIRE
Connector Color	WHITE

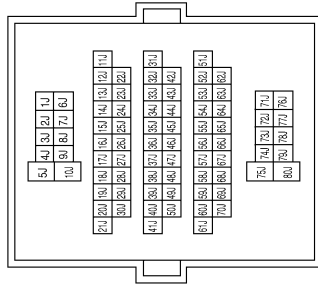

BCM (BODY CONTROL MODULE)

< ECU DIAGNOSIS >

Connector No.	B8
Connector Name	FRONT DOOR SWITCH LH
Connector Color	WHITE

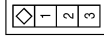

Terminal No.	Color of Wire	Signal Name
2	SB	-

Connector No.	B18
Connector Name	REAR DOOR SWITCH LH
Connector Color	WHITE

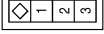

Terminal No.	Color of Wire	Signal Name
2	R/Y	-

Connector No.	B69
Connector Name	WIRE TO WIRE
Connector Color	WHITE

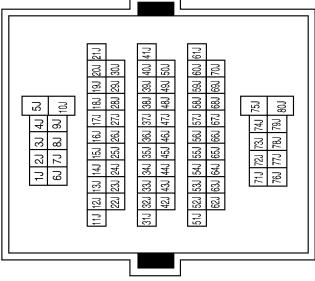

Terminal No.	Color of Wire	Signal Name
60J	SB	-
61J	R/Y	-
71J	G/Y	-
73J	V	-

Connector No.	B106
Connector Name	WIRE TO WIRE
Connector Color	WHITE

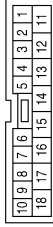

Terminal No.	Color of Wire	Signal Name
12	G/Y	-
13	V	-

Connector No.	B108
Connector Name	FRONT DOOR SWITCH RH
Connector Color	WHITE

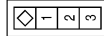

Terminal No.	Color of Wire	Signal Name
2	R/L	-

Connector No.	B116
Connector Name	REAR DOOR SWITCH RH
Connector Color	WHITE



Terminal No.	Color of Wire	Signal Name
2	GR	-

ALKIA1080GB

A B C D E F G H I J L M N O P

DLK

BCM (BODY CONTROL MODULE)

< ECU DIAGNOSIS >

Connector No.	B149
Connector Name	WIRE TO WIRE
Connector Color	WHITE

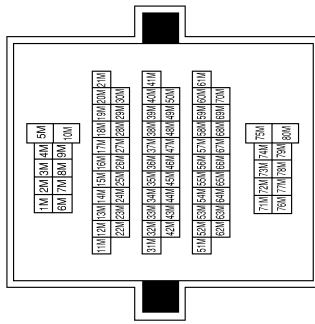

Terminal No.	Color of Wire	Signal Name
6M	G/Y	-
56M	GR	-
61M	R/L	-
74M	V	-

Connector No.	B156
Connector Name	REAR DOOR SWITCH UPPER RH
Connector Color	BLACK



Terminal No.	Color of Wire	Signal Name
1	R/L	-
2	B	-

Connector No.	B157
Connector Name	REAR DOOR SWITCH LOWER RH
Connector Color	BLACK



Terminal No.	Color of Wire	Signal Name
1	R/L	-
2	B	-

Connector No.	D2
Connector Name	WIRE TO WIRE
Connector Color	WHITE

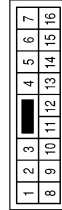

Terminal No.	Color of Wire	Signal Name
6	SHIELD	-
8	LG/W	-
12	G	-
13	V	-
14	B	-

Connector No.	D7
Connector Name	MAIN POWER WINDOW AND DOOR LOCK/UNLOCK SWITCH
Connector Color	WHITE

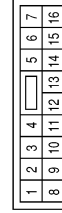

Terminal No.	Color of Wire	Signal Name
6	L	LOCK
7	R	UNLOCK
12	LGW	POWER WINDOW SERIAL LINK
15	B	GND

ALKIA1081GB

BCM (BODY CONTROL MODULE)

< ECU DIAGNOSIS >

Connector No.	D105
Connector Name	POWER WINDOW AND DOOR LOCK/UNLOCK SWITCH RH
Connector Color	WHITE

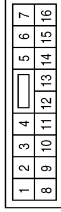

Terminal No.	Color of Wire	Signal Name
11	B	GND
16	LG/W	ANTI_PINCH_SERIAL_LINK

Connector No.	D101
Connector Name	WIRE TO WIRE
Connector Color	WHITE

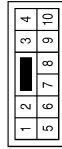

Terminal No.	Color of Wire	Signal Name
3	B	-
6	SHIELD	-
7	LG/W	-
8	V	-
9	G/Y	-

Connector No.	D14
Connector Name	FRONT DOOR LOCK ASSEMBLY LH
Connector Color	BLACK

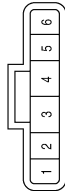

Terminal No.	Color of Wire	Signal Name
1	L	LOCK
2	G	UNLOCK
3	V	LOCK
5	B	GND
6	R	UNLOCK

Connector No.	D114
Connector Name	FRONT DOOR LOCK ACTUATOR RH
Connector Color	BLACK

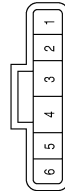

Terminal No.	Color of Wire	Signal Name
2	G/Y	UNLOCK
3	V	LOCK

A
B
C
D
E
F
G
H
I
J
DLK
L
M
N
O
P

ALKIA1082GB

BCM (BODY CONTROL MODULE)

< ECU DIAGNOSIS >

Wiring Diagram—POWER DOOR LOCK SYSTEM (CREW CAB)—

INFOID:000000001677680

POWER DOOR LOCK - CREW CAB

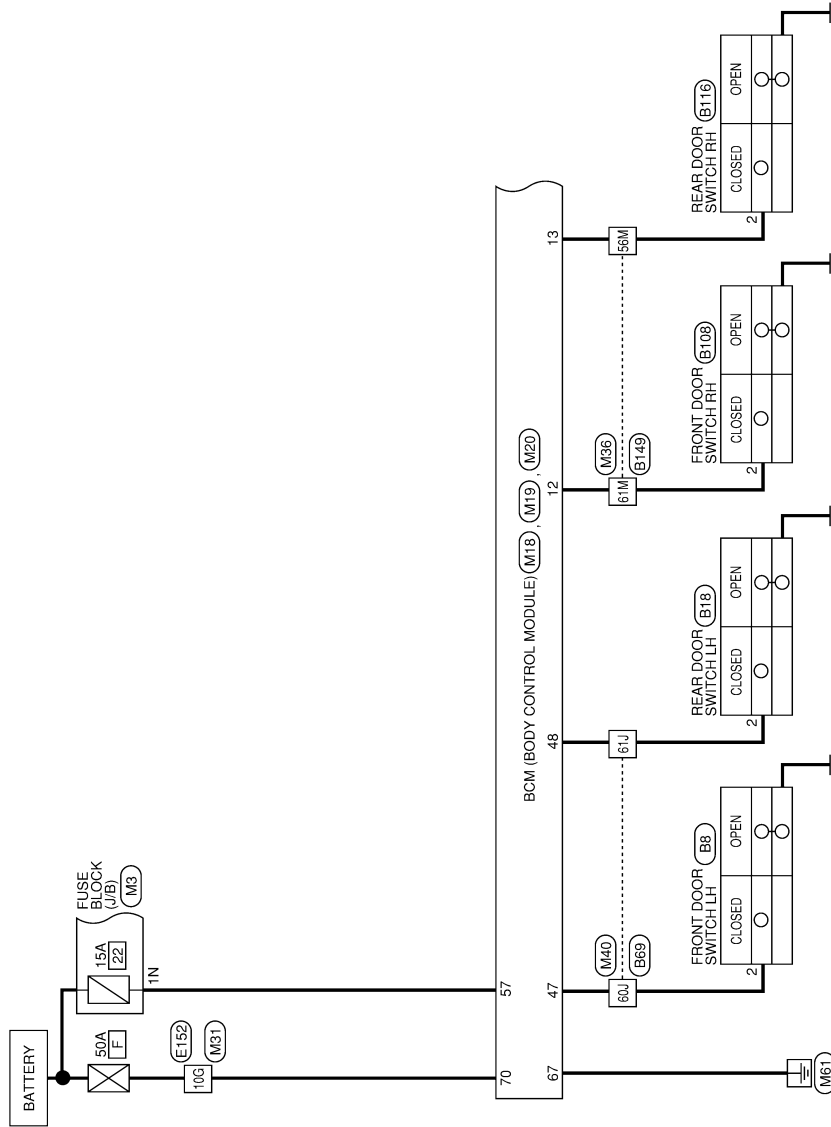

ALKWA0166GE

BCM (BODY CONTROL MODULE)

< ECU DIAGNOSIS >

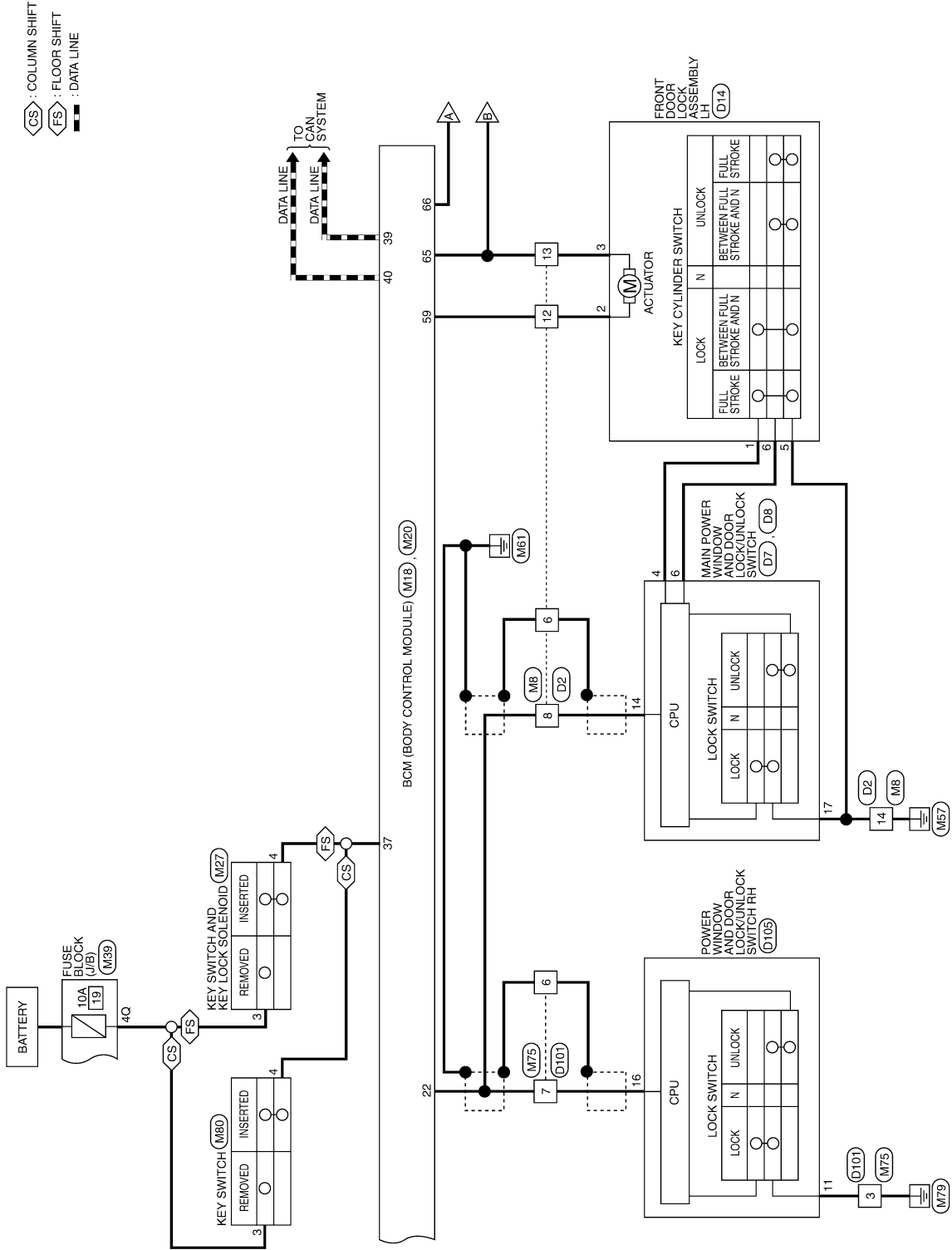

ALKWA0167GE

A
B
C
D
E
F
G
H
I
J
K
L
M
N
O
P

DLK

BCM (BODY CONTROL MODULE)

< ECU DIAGNOSIS >

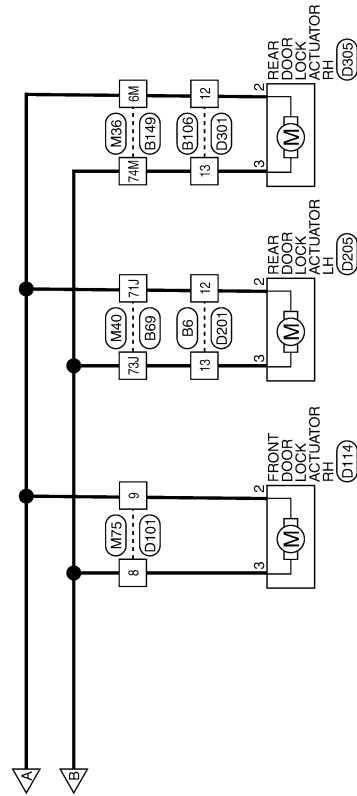

ALKWA0168GE

BCM (BODY CONTROL MODULE)

< ECU DIAGNOSIS >

POWER DOOR LOCK - CREW CAB CONNECTORS

Connector No.	M3
Connector Name	FUSE BLOCK (J/B)
Connector Color	WHITE

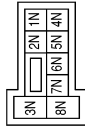

Terminal No.	Color of Wire	Signal Name
1N	Y/R	-

Connector No.	M8
Connector Name	WIRE TO WIRE
Connector Color	WHITE

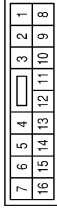

Terminal No.	Color of Wire	Signal Name
6	SHIELD	-
8	G	-
12	G	-
13	V	-
14	B	-

Connector No.	M18
Connector Name	BCM (BODY CONTROL MODULE)
Connector Color	WHITE

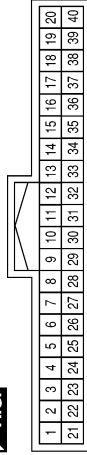

Terminal No.	Color of Wire	Signal Name
12	R/L	DOOR SW (AS)
13	GR	DOOR SW (RR)
22	G	ANTI-PINCH SERIAL LINK BUS
37	B/R	KEY_SW
39	L	CAN-H
40	P	CAN-L

Connector No.	M19
Connector Name	BCM (BODY CONTROL MODULE)
Connector Color	WHITE

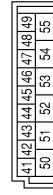

Terminal No.	Color of Wire	Signal Name
47	SB	DOOR SW (DR)
48	R/Y	DOOR SW (RL)

Connector No.	M20
Connector Name	BCM (BODY CONTROL MODULE)
Connector Color	BLACK



Terminal No.	Color of Wire	Signal Name
57	Y/R	B+ (ALL INT LIGHTS)
59	G	DL UNLOCK DR
65	V	DL LOCK ALL

Terminal No.	Color of Wire	Signal Name
66	G/Y	DL UNLOCK ALL
67	B	GND (POWER)
70	W/B	BATT (F/L)

A B C D E F G H I J L M N O P

DLK

BCM (BODY CONTROL MODULE)

< ECU DIAGNOSIS >

Connector No.	M27
Connector Name	KEY SWITCH AND KEY LOCK SOLENOID
Connector Color	WHITE

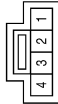

Terminal No.	Color of Wire	Signal Name
3	Y/R	-
4	B/R	-

Connector No.	M31
Connector Name	WIRE TO WIRE
Connector Color	WHITE

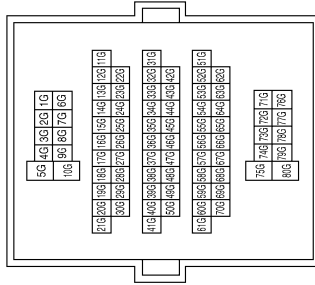

Terminal No.	Color of Wire	Signal Name
10G	W/B	-

Connector No.	M36
Connector Name	WIRE TO WIRE
Connector Color	WHITE

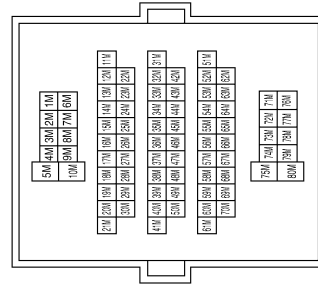

Terminal No.	Color of Wire	Signal Name
6M	G/Y	-
56M	GR	-
61M	R/L	-
74M	V	-

Connector No.	M39
Connector Name	FUSE BLOCK (J/B)
Connector Color	WHITE



Terminal No.	Color of Wire	Signal Name
4Q	Y/R	-

ALKIA1085GB

BCM (BODY CONTROL MODULE)

< ECU DIAGNOSIS >

Connector No.	M40
Connector Name	WIRE TO WIRE
Connector Color	WHITE

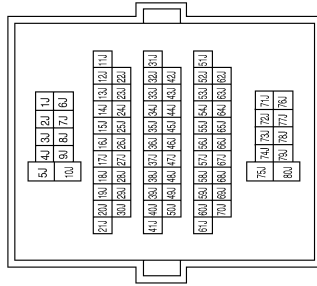

Terminal No.	Color of Wire	Signal Name
60J	SB	-
61J	R/Y	-
71J	G/Y	-
73J	V	-

Connector No.	M75
Connector Name	WIRE TO WIRE
Connector Color	WHITE

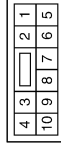

Terminal No.	Color of Wire	Signal Name
3	B	-
6	SHIELD	-
7	G	-
8	V	-
9	G/Y	-

Connector No.	M80
Connector Name	KEY SWITCH
Connector Color	WHITE



Terminal No.	Color of Wire	Signal Name
3	Y/R	-
4	B/R	-

Connector No.	E152
Connector Name	WIRE TO WIRE
Connector Color	WHITE

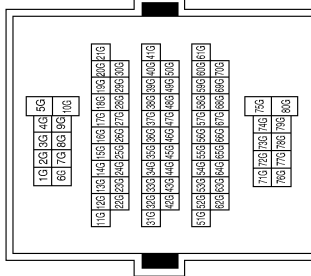

Terminal No.	Color of Wire	Signal Name
10G	W/B	-

Connector No.	B6
Connector Name	WIRE TO WIRE
Connector Color	WHITE

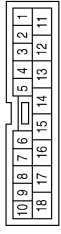

Terminal No.	Color of Wire	Signal Name
12	G/Y	-
13	V	-

ALKIA1086GB

A
B
C
D
E
F
G
H
I
J
DLK
L
M
N
O
P

BCM (BODY CONTROL MODULE)

< ECU DIAGNOSIS >

Connector No.	B8
Connector Name	FRONT DOOR SWITCH LH
Connector Color	WHITE

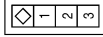

Terminal No.	Color of Wire	Signal Name
2	SB	-

Connector No.	B18
Connector Name	REAR DOOR SWITCH LH
Connector Color	WHITE

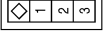

Terminal No.	Color of Wire	Signal Name
2	R/Y	-

Connector No.	B69
Connector Name	WIRE TO WIRE
Connector Color	WHITE

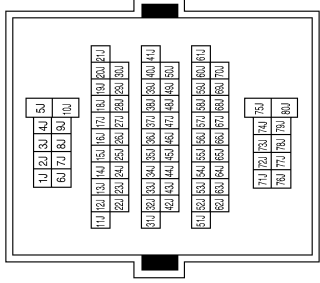

Terminal No.	Color of Wire	Signal Name
60J	SB	-
61J	R/Y	-
71J	G/Y	-
73J	V	-

Connector No.	B106
Connector Name	WIRE TO WIRE
Connector Color	WHITE

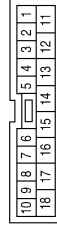

Terminal No.	Color of Wire	Signal Name
12	G/Y	-
13	V	-

Connector No.	B108
Connector Name	FRONT DOOR SWITCH RH
Connector Color	WHITE

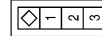

Terminal No.	Color of Wire	Signal Name
2	R/L	-

Connector No.	B116
Connector Name	REAR DOOR SWITCH RH
Connector Color	WHITE

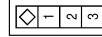

Terminal No.	Color of Wire	Signal Name
2	GR	-

ALKIA1087GB

BCM (BODY CONTROL MODULE)

< ECU DIAGNOSIS >

Connector No.	D2
Connector Name	WIRE TO WIRE
Connector Color	WHITE

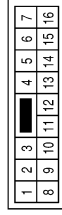

Terminal No.	Color of Wire	Signal Name
6	SHIELD	-
8	LG/W	-
12	G	-
13	V	-
14	B	-

Terminal No.	Color of Wire	Signal Name
6M	G/Y	-
56M	GR	-
61M	R/L	-
74M	V	-

Connector No.	B149
Connector Name	WIRE TO WIRE
Connector Color	WHITE

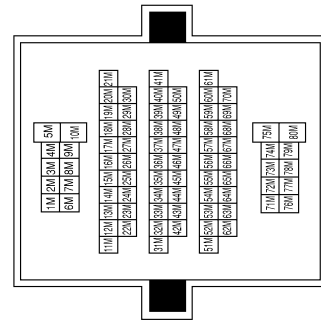

Connector No.	D14
Connector Name	FRONT DOOR LOCK ASSEMBLY LH
Connector Color	BLACK

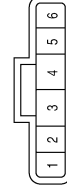

Terminal No.	Color of Wire	Signal Name
1	L	LOCK
2	G	UNLOCK
3	V	LOCK
5	B	GND
6	R	UNLOCK

Connector No.	D8
Connector Name	MAIN POWER WINDOW AND DOOR LOCK/UNLOCK SWITCH
Connector Color	WHITE

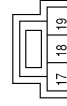

Terminal No.	Color of Wire	Signal Name
17	B	GND

Connector No.	D7
Connector Name	MAIN POWER WINDOW AND DOOR LOCK/UNLOCK SWITCH
Connector Color	WHITE

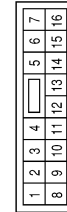

Terminal No.	Color of Wire	Signal Name
6	R	UNLOCK
7	R	-
12	LG/W	-
15	BR	-

ALKIA1088GB

A B C D E F G H I J L M N O P

DLK

BCM (BODY CONTROL MODULE)

< ECU DIAGNOSIS >

Connector No.	D114
Connector Name	FRONT DOOR LOCK ACTUATOR RH
Connector Color	BLACK

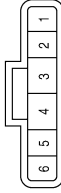

Terminal No.	Color of Wire	Signal Name
2	G/Y	UNLOCK
3	V	LOCK

Connector No.	D105
Connector Name	POWER WINDOW AND DOOR LOCK/UNLOCK SWITCH RH
Connector Color	WHITE

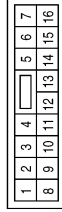

Terminal No.	Color of Wire	Signal Name
11	B	GND
16	LG/W	ANTI_PINCH_SERIAL_LINK

Connector No.	D101
Connector Name	WIRE TO WIRE
Connector Color	WHITE

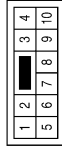

Terminal No.	Color of Wire	Signal Name
3	B	-
6	SHIELD	-
7	LG/W	-
8	V	-
9	G/Y	-

Connector No.	D301
Connector Name	WIRE TO WIRE
Connector Color	WHITE

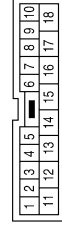

Terminal No.	Color of Wire	Signal Name
12	G/Y	-
13	V	-

Connector No.	D205
Connector Name	REAR DOOR LOCK ACTUATOR LH
Connector Color	BLACK

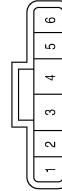

Terminal No.	Color of Wire	Signal Name
2	G/Y	UNLOCK
3	V	LOCK

Connector No.	D201
Connector Name	WIRE TO WIRE
Connector Color	WHITE

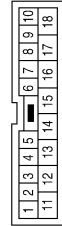

Terminal No.	Color of Wire	Signal Name
12	G/Y	-
13	V	-

ALKIA1089GB

BCM (BODY CONTROL MODULE)

< ECU DIAGNOSIS >

A
B
C
D
E
F
G
H
I
J
DLK
L
M
N
O
P

Connector No.	D305
Connector Name	REAR DOOR LOCK ACTUATOR RH
Connector Color	BLACK

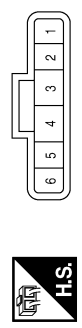

Terminal No.	Color of Wire	Signal Name
2	G/Y	UNLOCK
3	V	LOCK

ALKIA1090GB

BCM (BODY CONTROL MODULE)

< ECU DIAGNOSIS >

Wiring Diagram — REMOTE KEYLESS ENTRY SYSTEM —

INFOID:000000001546967

CS > COLUMN SHIFT
FS > FLOOR SHIFT

REMOTE KEYLESS ENTRY SYSTEM

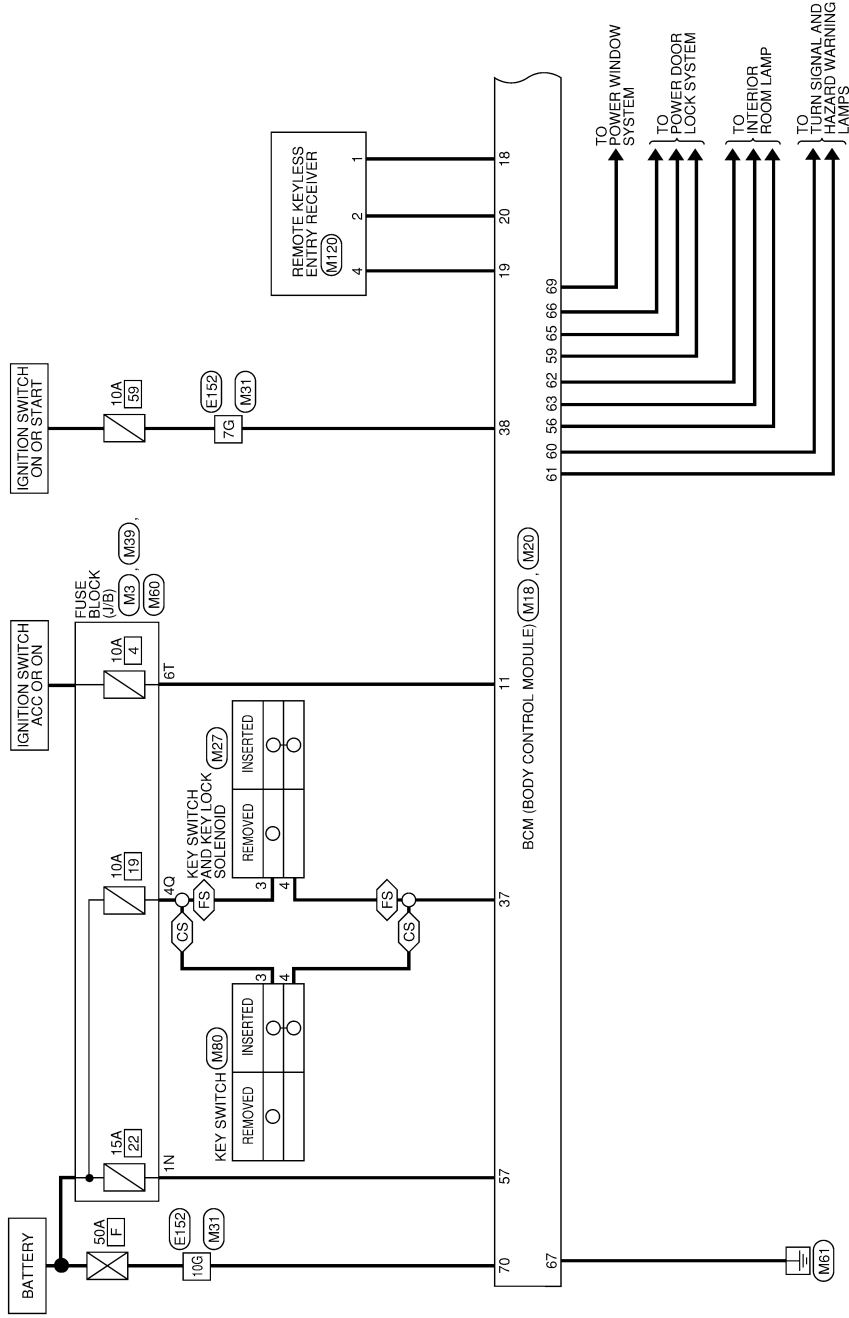

ALKWA0169GE

BCM (BODY CONTROL MODULE)

< ECU DIAGNOSIS >

— : DATA LINE

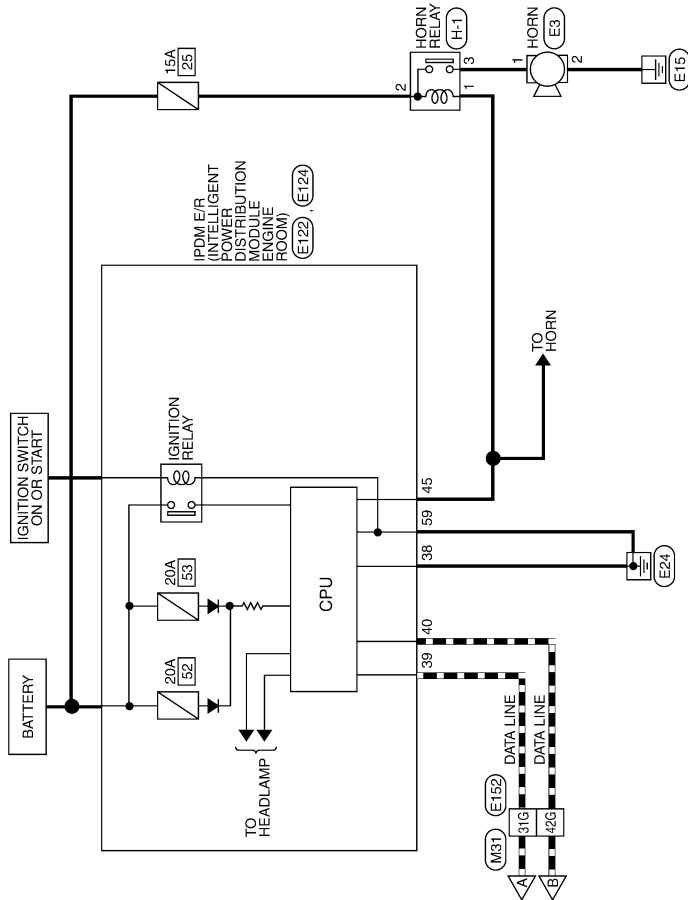

ALKWA0171GE

BCM (BODY CONTROL MODULE)

< ECU DIAGNOSIS >

REMOTE KEYLESS ENTRY SYSTEM CONNECTORS

Connector No.	M3
Connector Name	FUSE BLOCK (J/B)
Connector Color	WHITE

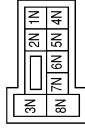

Terminal No.	Color of Wire	Signal Name
1N	Y/R	-

Connector No.	M18
Connector Name	BCM (BODY CONTROL MODULE)
Connector Color	WHITE

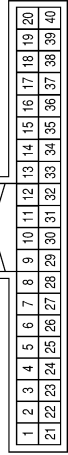

Terminal No.	Color of Wire	Signal Name
11	O	ACC SW
18	P	KEYLESS GND
19	V/W	KEYLESS PWR TUNER
20	G/W	KEYLESS TUNER SIGNAL
37	B/R	KEY SW
38	W/L	IGN SW
39	L	CAN-H
40	P	CAN-L

Connector No.	M20
Connector Name	BCM (BODY CONTROL MODULE)
Connector Color	BLACK



Terminal No.	Color of Wire	Signal Name
56	R/G	BATT SAVER
57	Y/R	B+ (ALL INT LIGHTS)
59	G	DL UNLOCK DR
60	G/B	FT LT FLASH OUTPUT

Terminal No.	Color of Wire	Signal Name
61	G/Y	FT RT FLASH OUTPUT
62	R/W	STEP LAMP OUTPUT
63	L	ROOM LAMP OUTPUT
65	V	DL LOCK ALL
66	G/Y	DL UNLOCK ALL
67	B	GND POWER
69	W/R	PWR SUPPLY BATT
70	W/B	BATT (FL)

Connector No.	M27
Connector Name	KEY SWITCH AND KEY LOCK SOLENOID
Connector Color	WHITE



Terminal No.	Color of Wire	Signal Name
3	Y/R	-
4	B/R	-

BCM (BODY CONTROL MODULE)

< ECU DIAGNOSIS >

Connector No.	M36
Connector Name	WIRE TO WIRE
Connector Color	WHITE

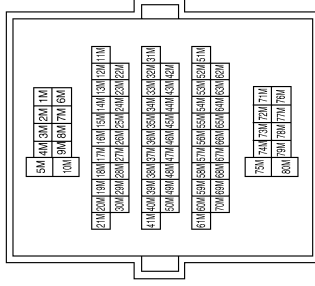

Terminal No.	Color of Wire	Signal Name
56M	GR	-
61M	R/L	-

Terminal No.	Color of Wire	Signal Name
7G	W/L	-
10G	W/B	-
31G	L	-
42G	P	-

Connector No.	M31
Connector Name	WIRE TO WIRE
Connector Color	WHITE

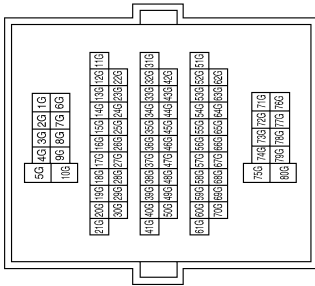

Connector No.	M40
Connector Name	WIRE TO WIRE
Connector Color	WHITE

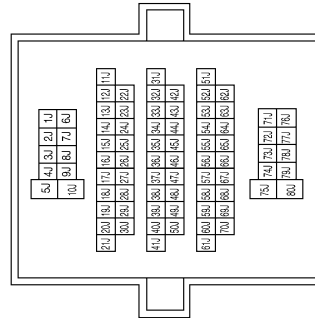

Terminal No.	Color of Wire	Signal Name
60J	SB	-
61J	R/Y	-

Connector No.	M39
Connector Name	FUSE BLOCK(J/B)
Connector Color	WHITE



Terminal No.	Color of Wire	Signal Name
4Q	Y/R	-

ALKIA1073GB

BCM (BODY CONTROL MODULE)

< ECU DIAGNOSIS >

Connector No.	M60
Connector Name	FUSE BLOCK (J/B)
Connector Color	WHITE

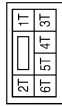

Terminal No.	Color of Wire	Signal Name
6T	O	-

Connector No.	M120
Connector Name	REMOTE KEYLESS ENTRY RECEIVER
Connector Color	WHITE

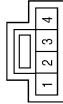

Terminal No.	Color of Wire	Signal Name
1	P	GND
2	G/W	SIGNAL
4	V/W	POWER

Connector No.	E3
Connector Name	HORN
Connector Color	BLACK



Terminal No.	Color of Wire	Signal Name
1	G	-
2	B	-

Connector No.	E122
Connector Name	IPDM E/R (INTELLIGENT POWER DISTRIBUTION MODULE ENGINE ROOM)
Connector Color	WHITE

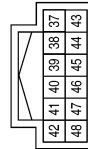

Terminal No.	Color of Wire	Signal Name
38	B	GND (SIG)
39	L	CAN-H
40	P	CAN-L
45	G/W	ANTI_THEFT_HORN

Connector No.	E124
Connector Name	IPDM E/R (INTELLIGENT POWER DISTRIBUTION MODULE ENGINE ROOM)
Connector Color	BLACK



Terminal No.	Color of Wire	Signal Name
59	B	GND (PWR)

ALKIA1074GB

A
B
C
D
E
F
G
H
I
J
DLK
L
M
N
O
P

BCM (BODY CONTROL MODULE)

< ECU DIAGNOSIS >

Connector No.	E152
Connector Name	WIRE TO WIRE
Connector Color	WHITE

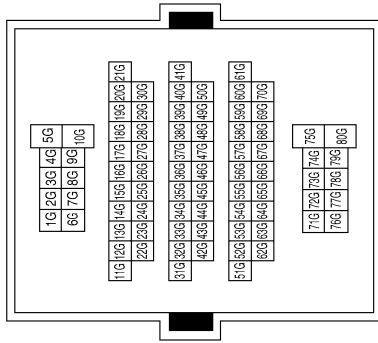

Terminal No.	Color of Wire	Signal Name
7G	L/W	-
10G	W/B	-
31G	L	-
42G	P	-

Connector No.	B8
Connector Name	FRONT DOOR SWITCH LH
Connector Color	WHITE

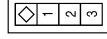

Terminal No.	Color of Wire	Signal Name
2	SB	-
3	B	-

Connector No.	B18
Connector Name	REAR DOOR SWITCH LH
Connector Color	WHITE

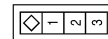

Terminal No.	Color of Wire	Signal Name
2	R/Y	-

Connector No.	B69
Connector Name	WIRE TO WIRE
Connector Color	WHITE

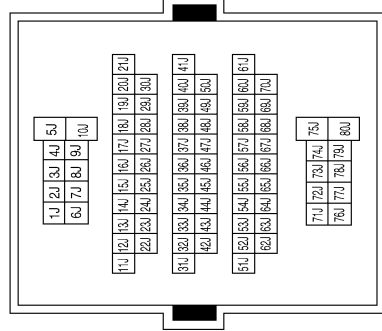

Terminal No.	Color of Wire	Signal Name
60J	SB	-
61J	R/Y	-

BCM (BODY CONTROL MODULE)

< ECU DIAGNOSIS >

Connector No.	B73
Connector Name	REAR DOOR SWITCH UPPER LH
Connector Color	BLACK



Terminal No.	Color of Wire	Signal Name
1	SB	-
2	B	-

Connector No.	B74
Connector Name	REAR DOOR SWITCH LOWER LH
Connector Color	BLACK



Terminal No.	Color of Wire	Signal Name
1	SB	-
2	B	-

Connector No.	B108
Connector Name	FRONT DOOR SWITCH RH
Connector Color	WHITE

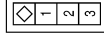

Terminal No.	Color of Wire	Signal Name
2	R/L	-
3	B	-

Connector No.	B116
Connector Name	REAR DOOR SWITCH
Connector Color	WHITE

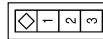

Terminal No.	Color of Wire	Signal Name
2	GR	-

Connector No.	B149
Connector Name	WIRE TO WIRE
Connector Color	WHITE

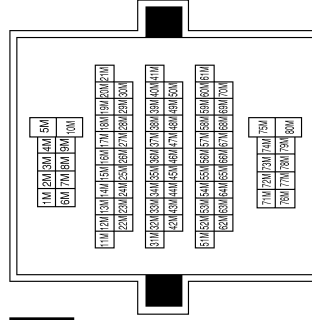

Terminal No.	Color of Wire	Signal Name
56M	GR	-
61M	R/L	-

Connector No.	B156
Connector Name	REAR DOOR SWITCH UPPER RH
Connector Color	BLACK



Terminal No.	Color of Wire	Signal Name
1	R/L	-
2	B	-

ALKIA1076GB



A
B
C
D
E
F
G
H
I
J
L
M
N
O
P

DLK

BCM (BODY CONTROL MODULE)

< ECU DIAGNOSIS >

Connector No.	B157
Connector Name	REAR DOOR SWITCH LOWER RH
Connector Color	BLACK



Terminal No.	Color of Wire	Signal Name
1	R/L	-
2	B	-

ALKIA1092GB

INFOID:000000001546968

Fail Safe

Fail-safe index

BCM performs fail-safe control when any DTC listed below is detected.

BCM (BODY CONTROL MODULE)

< ECU DIAGNOSIS >

Display contents of CONSULT	Fail-safe	Cancellation
U1000: CAN COMM CIRCUIT	Inhibit engine cranking	When the BCM re-establishes communication with the other modules.
U1010: CONTROL UNIT (CAN)	Inhibit engine cranking	When the BCM re-start communicating with the other modules.

DTC Inspection Priority Chart

INFOID:000000001546969

If some DTCs are displayed at the same time, perform inspections one by one based on the following priority chart.

Priority	DTC
1	<ul style="list-style-type: none"> • U1000: CAN COMM CIRCUIT • U1010: CONTROL UNIT (CAN)

DTC Index

INFOID:000000001546970

NOTE:

- Details of time display
- CRNT: Displays when there is a malfunction now or after returning to the normal condition until turning ignition switch OFF → ON again.
- 1 - 39: Displayed if any previous malfunction is present when current condition is normal. It increases like 1 → 2 → 3...38 → 39 after returning to the normal condition whenever ignition switch OFF → ON. The counter remains at 39 even if the number of cycles exceeds it. It is counted from 1 again when turning ignition switch OFF → ON after returning to the normal condition if the malfunction is detected again.

CONSULT display	Fail-safe	Intelligent Key warning lamp ON	Reference page
No DTC is detected. further testing may be required.	—	—	—
U1000: CAN COMM CIRCUIT	—	—	DLK-18
U1010: CONTROL UNIT (CAN)	—	—	DLK-19

A
B
C
D
E
F
G
H
I
J
L
M
N
O
P

DLK

HOMELINK UNIVERSAL TRANSCEIVER

< ECU DIAGNOSIS >

HOMELINK UNIVERSAL TRANSCEIVER

Wiring Diagram

INFOID:000000001546974

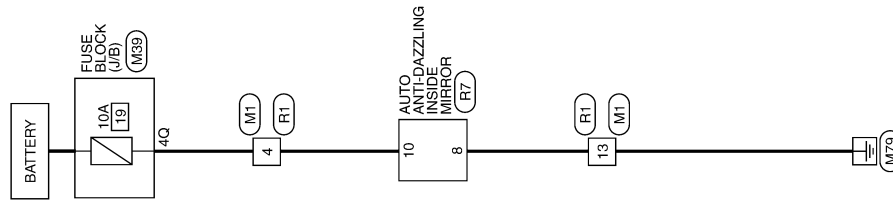

INTEGRATED HOMELINK TRANSMITTER

ALKWA0163GE

HOMELINK UNIVERSAL TRANSCEIVER

< ECU DIAGNOSIS >

INTEGRATED HOMELINK TRANSMITTER CONNECTORS

Connector No.	M1
Connector Name	WIRE TO WIRE
Connector Color	WHITE

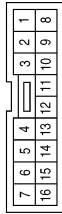

Terminal No.	Color of Wire	Signal Name
4	Y/R	-
13	B	-

Connector No.	M39
Connector Name	FUSE BLOCK (J/B)
Connector Color	WHITE

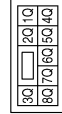

Terminal No.	Color of Wire	Signal Name
4Q	Y/R	-

Connector No.	R1
Connector Name	WIRE TO WIRE
Connector Color	WHITE

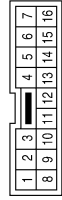

Terminal No.	Color of Wire	Signal Name
4	Y/R	-
13	B	-

Connector No.	R7
Connector Name	AUTO ANTI-DAZZLING INSIDE MIRROR
Connector Color	GRAY

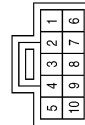

Terminal No.	Color of Wire	Signal Name
8	B	GND
10	Y/R	B+

ALKIA1083GB

A
B
C
D
E
F
G
H
I
J
DLK
L
M
N
O
P

DOOR LOCK

< SYMPTOM DIAGNOSIS >

SYMPTOM DIAGNOSIS

DOOR LOCK

Symptom Table

INFOID:000000001546975

DOOR LOCK SYSTEM

NOTE:

- Before performing the diagnosis in the following table, check “Work flow”. Refer to [DLK-4, "Work Flow"](#).
- If the following symptoms are detected, check systems shown in the “Diagnosis/service procedure” column in this order.

Symptom	Repair order	Refer to page
Key reminder door function does not operate properly.	1a. Door switch check (king cab)	DLK-21
	1b. Door switch check (crew cab)	DLK-22
	2a. Key switch (Insert) check (column shift)	DLK-34
	2b. Key switch (Insert) check (floor shift)	DLK-35
	3. Replace BCM.	BCS-50
Power door lock does not operate with door lock and unlock switch on main power window and door lock/unlock switch or power window and door lock/unlock switch RH.	1. Door lock/unlock switch check (driver side)	DLK-25
	2. Door lock/unlock switch check (passenger side)	DLK-27
Specific door lock actuator does not operate.	1. Door lock actuator check (Front LH)	DLK-37
	2. Door lock actuator check (Front RH)	DLK-38
	3. Door lock actuator check (Rear LH)	DLK-39
	4. Door lock actuator check (Rear RH)	DLK-39
Power door lock does not operate with front door key cylinder LH operation.	1. Front door lock assembly LH (key cylinder switch) check	DLK-30
	2. Replace BCM.	BCS-50
Power door lock does not operate.	1. BCM power supply and ground circuit check	BCS-29
	2. Door lock/unlock switch check	DLK-25

REMOTE KEYLESS ENTRY SYSTEM

< SYMPTOM DIAGNOSIS >

REMOTE KEYLESS ENTRY SYSTEM

Symptom Table

INFOID:000000001546976

REMOTE KEYLESS ENTRY SYSTEM

Symptom	Diagnoses/service procedure	Reference page
All functions of remote keyless entry system do not operate.	1. Keyfob battery and function check (use Remote Keyless Entry Tester J-43241) NOTE: If the result of keyfob function check is OK, keyfob is not malfunctioning.	DLK-42
	2. Check BCM and remote keyless entry receiver.	DLK-40
The new ID of keyfob cannot be entered.	1. Keyfob battery and function check (use Remote Keyless Entry Tester J-43241) NOTE: If the result of keyfob function check is OK, keyfob is not malfunctioning.	DLK-42
	2a. Key switch (insert) check (column shift)	DLK-34
	2b. Key switch (insert) check (floor shift)	DLK-35
	3a. Door switch check (king cab)	DLK-21
	3b. Door switch check (crew cab)	DLK-22
	4. ACC power check	BCS-29
	5. Replace BCM.	BCS-50
Door lock or unlock does not function. (If the power door lock system does not operate manually, check power door lock system)	1. Keyfob battery and function check (use Remote Keyless Entry Tester J-43241) NOTE: If the result of keyfob function check is OK, keyfob is not malfunctioning.	DLK-10
	2. Replace BCM.	BCS-50
Hazard and horn reminder does not activate properly when pressing lock or unlock button of keyfob.	1. Check hazard and horn reminder mode with CONSULT-III NOTE: Hazard and horn reminder mode can be changed. First check the hazard and horn reminder mode setting.	DLK-10
	2a. Door switch check (king cab)	DLK-21
	2b. Door switch check (crew cab)	DLK-22
	3. Replace BCM.	BCS-50
Hazard reminder does not activate properly when pressing lock or unlock button of keyfob. (Horn reminder OK)	1. Check hazard reminder mode with CONSULT-III NOTE: Hazard reminder mode can be changed. First check the hazard reminder mode setting.	DLK-10
	2. Check hazard function with hazard switch	—
	3. Replace BCM.	BCS-50
Horn reminder does not activate properly when pressing lock or unlock button of keyfob. (Hazard reminder OK)	1. Check horn reminder mode with CONSULT-III NOTE: Horn reminder mode can be changed. First check the horn reminder mode setting.	DLK-10
	2. Check horn function with horn switch	—
	3. IPDM E/R operation check	DLK-44
	4. Replace BCM.	BCS-50
Room lamp, ignition keyhole illumination and step lamp operation do not activate properly.	1. Room lamp operation check	—

A

B

C

D

E

F

G

H

I

J

DLK

L

M

N

O

P

REMOTE KEYLESS ENTRY SYSTEM

< SYMPTOM DIAGNOSIS >

Symptom	Diagnoses/service procedure	Reference page
	2. Ignition keyhole illumination operation check	—
	3. Step lamp operation check	—
	4a. Door switch check (king cab)	DLK-21
	4b. Door switch check (crew cab)	DLK-22
	5. Replace BCM.	BCS-50
Panic alarm (horn and headlamp) does not activate when panic alarm button is continuously pressed.	1. Keyfob battery and function check (use Remote Keyless Entry Tester J-43241) NOTE: If the result of keyfob function check is OK, keyfob is not malfunctioning.	DLK-42
	2a. Key switch (insert) check (column shift)	DLK-34
	2b. Key switch (insert) check (floor shift)	DLK-35
	3. Replace BCM.	BCS-50
Auto door lock operation does not activate properly. (All other remote keyless entry functions OK.)	1. Check auto door lock operation mode with CONSULT-III NOTE: Auto door lock operation mode can be changed. First check the auto door lock operation mode setting.	DLK-8
	2. Replace BCM.	BCS-50
Keyless power window down (open) operation does not activate properly. (All other remote keyless entry functions OK.)	1. Check power window down operation mode with CONSULT-III NOTE: Power window down operation mode can be changed. First check the power window down operation mode setting.	—
	2. Check power window function with switch	—
	3. Replace BCM.	BCS-50

HOMELINK UNIVERSAL TRANSCEIVER

< SYMPTOM DIAGNOSIS >

HOMELINK UNIVERSAL TRANSCEIVER

Symptom Table

INFOID:000000001546979

HOMELINK UNIVERSAL TRANSCEIVER MALFUNCTION

Symptom	Diagnosis/service procedure	Reference page
Homelink universal transceiver does not operate properly.	1. Check homelink universal transceiver function.	DLK-53
	2. Check Intermittent Incident.	GI-41

A
B
C
D
E
F
G
H
I
J
L
M
N
O
P

DLK

SQUEAK AND RATTLE TROUBLE DIAGNOSES

< SYMPTOM DIAGNOSIS >

SQUEAK AND RATTLE TROUBLE DIAGNOSES

Work Flow

INFOID:000000001329023

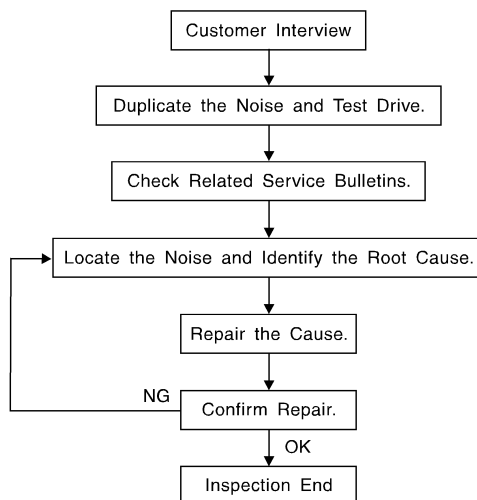

SBT842

CUSTOMER INTERVIEW

Interview the customer if possible, to determine the conditions that exist when the noise occurs. Use the Diagnostic Worksheet during the interview to document the facts and conditions when the noise occurs and any customer's comments; refer to [DLK-94, "Diagnostic Worksheet"](#). This information is necessary to duplicate the conditions that exist when the noise occurs.

- The customer may not be able to provide a detailed description or the location of the noise. Attempt to obtain all the facts and conditions that exist when the noise occurs (or does not occur).
- If there is more than one noise in the vehicle, be sure to diagnose and repair the noise that the customer is concerned about. This can be accomplished by test driving the vehicle with the customer.
- After identifying the type of noise, isolate the noise in terms of its characteristics. The noise characteristics are provided so the customer, service adviser and technician are all speaking the same language when defining the noise.
- Squeak —(Like tennis shoes on a clean floor)
Squeak characteristics include the light contact/fast movement/brought on by road conditions/hard surfaces = higher pitch noise/softer surfaces = lower pitch noises/edge to surface = chirping.
- Creak—(Like walking on an old wooden floor)
Creak characteristics include firm contact/slow movement/twisting with a rotational movement/pitch dependent on materials/often brought on by activity.
- Rattle—(Like shaking a baby rattle)
Rattle characteristics include the fast repeated contact/vibration or similar movement/loose parts/missing clip or fastener/incorrect clearance.
- Knock —(Like a knock on a door)
Knock characteristics include hollow sounding/sometimes repeating/often brought on by driver action.
- Tick—(Like a clock second hand)
Tick characteristics include gentle contacting of light materials/loose components/can be caused by driver action or road conditions.
- Thump—(Heavy, muffled knock noise)
Thump characteristics include softer knock/dead sound often brought on by activity.
- Buzz—(Like a bumble bee)
Buzz characteristics include high frequency rattle/firm contact.
- Often the degree of acceptable noise level will vary depending upon the person. A noise that you may judge as acceptable may be very irritating to the customer.
- Weather conditions, especially humidity and temperature, may have a great effect on noise level.

DUPLICATE THE NOISE AND TEST DRIVE

If possible, drive the vehicle with the customer until the noise is duplicated. Note any additional information on the Diagnostic Worksheet regarding the conditions or location of the noise. This information can be used to duplicate the same conditions when you confirm the repair.

SQUEAK AND RATTLE TROUBLE DIAGNOSES

< SYMPTOM DIAGNOSIS >

If the noise can be duplicated easily during the test drive, to help identify the source of the noise, try to duplicate the noise with the vehicle stopped by doing one or all of the following:

- 1) Close a door.
 - 2) Tap or push/pull around the area where the noise appears to be coming from.
 - 3) Rev the engine.
 - 4) Use a floor jack to recreate vehicle "twist".
 - 5) At idle, apply engine load (electrical load, drive position on A/T model).
 - 6) Raise the vehicle on a hoist and hit a tire with a rubber hammer.
- Drive the vehicle and attempt to duplicate the conditions the customer states exist when the noise occurs.
 - If it is difficult to duplicate the noise, drive the vehicle slowly on an undulating or rough road to stress the vehicle body.

CHECK RELATED SERVICE BULLETINS

After verifying the customer concern or symptom, check ASIST for Technical Service Bulletins (TSBs) related to that concern or symptom.

If a TSB relates to the symptom, follow the procedure to repair the noise.

LOCATE THE NOISE AND IDENTIFY THE ROOT CAUSE

1. Narrow down the noise to a general area. To help pinpoint the source of the noise, use a listening tool (Chassis Ear: J-39570, Engine Ear: J-39565 and mechanic's stethoscope).
2. Narrow down the noise to a more specific area and identify the cause of the noise by:
 - removing the components in the area that you suspect the noise is coming from.
Do not use too much force when removing clips and fasteners, otherwise clips and fasteners can be broken or lost during the repair, resulting in the creation of new noise.
 - tapping or pushing/pulling the component that you suspect is causing the noise.
Do not tap or push/pull the component with excessive force, otherwise the noise will be eliminated only temporarily.
 - feeling for a vibration with your hand by touching the component(s) that you suspect is (are) causing the noise.
 - placing a piece of paper between components that you suspect are causing the noise.
 - looking for loose components and contact marks.
Refer to [DLK-92, "Generic Squeak and Rattle Troubleshooting"](#).

REPAIR THE CAUSE

- If the cause is a loose component, tighten the component securely.
- If the cause is insufficient clearance between components:
 - separate components by repositioning or loosening and retightening the component, if possible.
 - insulate components with a suitable insulator such as urethane pads, foam blocks, felt cloth tape or urethane tape. A NISSAN Squeak and Rattle Kit (J-43980) is available through your authorized NISSAN Parts Department.

CAUTION:

Do not use excessive force as many components are constructed of plastic and may be damaged.

Always check with the Parts Department for the latest parts information.

The following materials are contained in the NISSAN Squeak and Rattle Kit (J-43980). Each item can be ordered separately as needed.

URETHANE PADS [1.5 mm (0.059 in) thick]

Insulates connectors, harness, etc.

76268-9E005: 100×135 mm (3.94×5.31 in)/76884-71L01: 60×85 mm (2.36×3.35 in)/76884-71L02: 15×25 mm (0.59×0.98 in)

INSULATOR (Foam blocks)

Insulates components from contact. Can be used to fill space behind a panel.

73982-9E000: 45 mm (1.77 in) thick, 50×50 mm (1.97×1.97 in)/73982-50Y00: 10 mm (0.39 in) thick, 50×50 mm (1.97×1.97 in)

INSULATOR (Light foam block)

80845-71L00: 30 mm (1.18 in) thick, 30×50 mm (1.18×1.97 in)

FELT CLOTH TAPE

Used to insulate where movement does not occur. Ideal for instrument panel applications.

68370-4B000: 15×25 mm (0.59×0.98 in) pad/68239-13E00: 5 mm (0.20 in) wide tape roll. The following materials not found in the kit can also be used to repair squeaks and rattles.

UHMW (TEFLON) TAPE

Insulates where slight movement is present. Ideal for instrument panel applications.

SQUEAK AND RATTLE TROUBLE DIAGNOSES

< SYMPTOM DIAGNOSIS >

SILICONE GREASE

Used instead of UHMW tape that will be visible or not fit.

Note: Will only last a few months.

SILICONE SPRAY

Use when grease cannot be applied.

DUCT TAPE

Use to eliminate movement.

CONFIRM THE REPAIR

Confirm that the cause of a noise is repaired by test driving the vehicle. Operate the vehicle under the same conditions as when the noise originally occurred. Refer to the notes on the Diagnostic Worksheet.

Generic Squeak and Rattle Troubleshooting

INFOID:000000001329024

Refer to Table of Contents for specific component removal and installation information.

INSTRUMENT PANEL

Most incidents are caused by contact and movement between:

1. The cluster lid A and instrument panel
2. Acrylic lens and combination meter housing
3. Instrument panel to front pillar garnish
4. Instrument panel to windshield
5. Instrument panel mounting pins
6. Wiring harnesses behind the combination meter
7. A/C defroster duct and duct joint

These incidents can usually be located by tapping or moving the components to duplicate the noise or by pressing on the components while driving to stop the noise. Most of these incidents can be repaired by applying felt cloth tape or silicone spray (in hard to reach areas). Urethane pads can be used to insulate wiring harness.

CAUTION:

Do not use silicone spray to isolate a squeak or rattle. If you saturate the area with silicone, you will not be able to recheck the repair.

CENTER CONSOLE

Components to pay attention to include:

1. Shifter assembly cover to finisher
2. A/C control unit and cluster lid C
3. Wiring harnesses behind audio and A/C control unit

The instrument panel repair and isolation procedures also apply to the center console.

DOORS

Pay attention to the:

1. Finisher and inner panel making a slapping noise
2. Inside handle escutcheon to door finisher
3. Wiring harnesses tapping
4. Door striker out of alignment causing a popping noise on starts and stops

Tapping or moving the components or pressing on them while driving to duplicate the conditions can isolate many of these incidents. You can usually insulate the areas with felt cloth tape or insulator foam blocks from the NISSAN Squeak and Rattle Kit (J-43980) to repair the noise.

TRUNK

Trunk noises are often caused by a loose jack or loose items put into the trunk by the owner.

In addition look for:

1. Trunk lid bumpers out of adjustment
2. Trunk lid striker out of adjustment
3. The trunk lid torsion bars knocking together
4. A loose license plate or bracket

SQUEAK AND RATTLE TROUBLE DIAGNOSES

< SYMPTOM DIAGNOSIS >

Most of these incidents can be repaired by adjusting, securing or insulating the item(s) or component(s) causing the noise.

SUNROOF/HEADLINING

Noises in the sunroof/headlining area can often be traced to one of the following:

1. Sunroof lid, rail, linkage or seals making a rattle or light knocking noise
2. Sun visor shaft shaking in the holder
3. Front or rear windshield touching headliner and squeaking

Again, pressing on the components to stop the noise while duplicating the conditions can isolate most of these incidents. Repairs usually consist of insulating with felt cloth tape.

OVERHEAD CONSOLE (FRONT AND REAR)

Overhead console noises are often caused by the console panel clips not being engaged correctly. Most of these incidents are repaired by pushing up on the console at the clip locations until the clips engage.

In addition look for:

1. Loose harness or harness connectors.
2. Front console map/reading lamp lense loose.
3. Loose screws at console attachment points.

SEATS

When isolating seat noise it's important to note the position the seat is in and the load placed on the seat when the noise is present. These conditions should be duplicated when verifying and isolating the cause of the noise.

Cause of seat noise include:

1. Headrest rods and holder
2. A squeak between the seat pad cushion and frame
3. The rear seatback lock and bracket

These noises can be isolated by moving or pressing on the suspected components while duplicating the conditions under which the noise occurs. Most of these incidents can be repaired by repositioning the component or applying urethane tape to the contact area.

UNDERHOOD

Some interior noise may be caused by components under the hood or on the engine wall. The noise is then transmitted into the passenger compartment.

Causes of transmitted underhood noise include:

1. Any component mounted to the engine wall
2. Components that pass through the engine wall
3. Engine wall mounts and connectors
4. Loose radiator mounting pins
5. Hood bumpers out of adjustment
6. Hood striker out of adjustment

These noises can be difficult to isolate since they cannot be reached from the interior of the vehicle. The best method is to secure, move or insulate one component at a time and test drive the vehicle. Also, engine RPM or load can be changed to isolate the noise. Repairs can usually be made by moving, adjusting, securing, or insulating the component causing the noise.

A
B
C
D
E
F
G
H
I
J
L
M
N
O
P

DLK

SQUEAK AND RATTLE TROUBLE DIAGNOSES

< SYMPTOM DIAGNOSIS >

Diagnostic Worksheet

INFOID:000000001329025

Dear Customer:

We are concerned about your satisfaction with your vehicle. Repairing a squeak or rattle sometimes can be very difficult. To help us fix your vehicle right the first time, please take a moment to note the area of the vehicle where the squeak or rattle occurs and under what conditions. You may be asked to take a test drive with a service advisor or technician to ensure we confirm the noise you are hearing.

SQUEAK & RATTLE DIAGNOSTIC WORKSHEET

I. WHERE DOES THE NOISE COME FROM? (circle the area of the vehicle)

The illustrations are for reference only, and may not reflect the actual configuration of your vehicle.

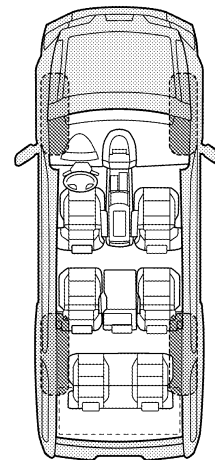
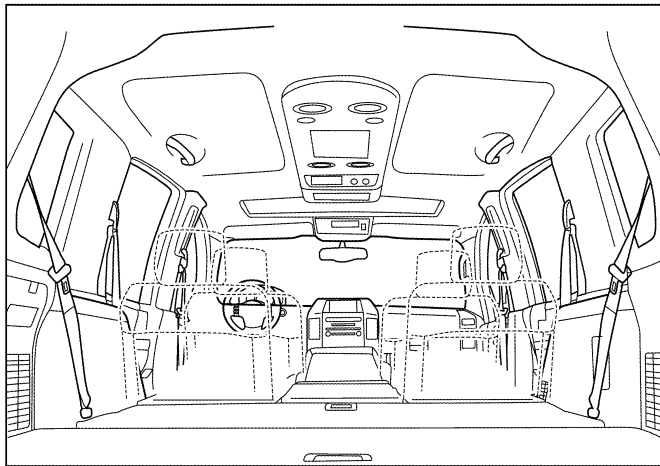
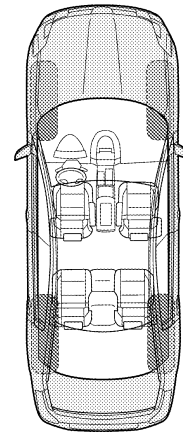
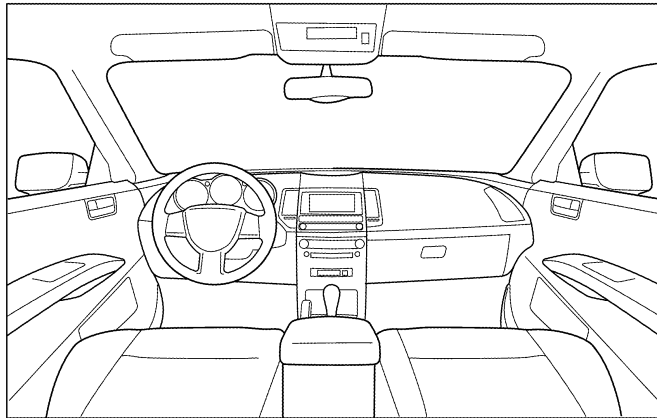

Continue to page 2 of the worksheet and briefly describe the location of the noise or rattle. In addition, please indicate the conditions which are present when the noise occurs.

SQUEAK AND RATTLE TROUBLE DIAGNOSES

< SYMPTOM DIAGNOSIS >

SQUEAK & RATTLE DIAGNOSTIC WORKSHEET - page 2

Briefly describe the location where the noise occurs:

II. WHEN DOES IT OCCUR? (please check the boxes that apply)

- | | |
|---|--|
| <input type="checkbox"/> Anytime | <input type="checkbox"/> After sitting out in the rain |
| <input type="checkbox"/> 1st time in the morning | <input type="checkbox"/> When it is raining or wet |
| <input type="checkbox"/> Only when it is cold outside | <input type="checkbox"/> Dry or dusty conditions |
| <input type="checkbox"/> Only when it is hot outside | <input type="checkbox"/> Other: |

III. WHEN DRIVING:

- Through driveways
- Over rough roads
- Over speed bumps
- Only about ____ mph
- On acceleration
- Coming to a stop
- On turns: left, right or either (circle)
- With passengers or cargo
- Other: _____
- After driving ____ miles or ____ minutes

IV. WHAT TYPE OF NOISE

- Squeak (like tennis shoes on a clean floor)
- Creak (like walking on an old wooden floor)
- Rattle (like shaking a baby rattle)
- Knock (like a knock at the door)
- Tick (like a clock second hand)
- Thump (heavy muffled knock noise)
- Buzz (like a bumble bee)

TO BE COMPLETED BY DEALERSHIP PERSONNEL

Test Drive Notes:

	YES	NO	Initials of person performing
Vehicle test driven with customer	<input type="checkbox"/>	<input type="checkbox"/>	_____
- Noise verified on test drive	<input type="checkbox"/>	<input type="checkbox"/>	_____
- Noise source located and repaired	<input type="checkbox"/>	<input type="checkbox"/>	_____
- Follow up test drive performed to confirm repair	<input type="checkbox"/>	<input type="checkbox"/>	_____

VIN: _____ Customer Name _____

W.O.# _____ Date: _____

This form must be attached to Work Order

LAI0071E

A
B
C
D
E
F
G
H
I
J
L
M
N
O
P

DLK

PRECAUTIONS

< PRECAUTION >

PRECAUTION

PRECAUTIONS

Precaution for Supplemental Restraint System (SRS) "AIR BAG" and "SEAT BELT PRE-TENSIONER"

INFOID:000000001329026

The Supplemental Restraint System such as "AIR BAG" and "SEAT BELT PRE-TENSIONER", used along with a front seat belt, helps to reduce the risk or severity of injury to the driver and front passenger for certain types of collision. This system includes seat belt switch inputs and dual stage front air bag modules. The SRS system uses the seat belt switches to determine the front air bag deployment, and may only deploy one front air bag, depending on the severity of a collision and whether the front occupants are belted or unbelted. Information necessary to service the system safely is included in the SR and SB section of this Service Manual.

WARNING:

- **To avoid rendering the SRS inoperative, which could increase the risk of personal injury or death in the event of a collision which would result in air bag inflation, all maintenance must be performed by an authorized NISSAN/INFINITI dealer.**
- **Improper maintenance, including incorrect removal and installation of the SRS, can lead to personal injury caused by unintentional activation of the system. For removal of Spiral Cable and Air Bag Module, see the SR section.**
- **Do not use electrical test equipment on any circuit related to the SRS unless instructed to in this Service Manual. SRS wiring harnesses can be identified by yellow and/or orange harnesses or harness connectors.**

Precaution for work

INFOID:000000001329027

- After removing and installing the opening/closing parts, be sure to carry out fitting adjustments to check their operation.
- Check the lubrication level, damage, and wear of each part. If necessary, grease or replace it.

PREPARATION

< PREPARATION >

PREPARATION

PREPARATION

Special Service Tool

INFOID:000000001329028

The actual shapes of Kent-Moore tools may differ from those of special service tools illustrated here.

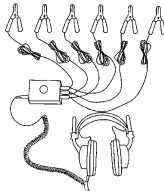
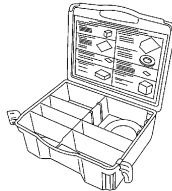
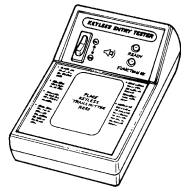
Tool number (Kent-Moore No.) Tool name	Description
<p>— (J-39570) Chassis ear</p>  <p>SIA0993E</p>	<p>Locating the noise</p>
<p>— (J-43980) NISSAN Squeak and Rattle Kit</p>  <p>SIA0994E</p>	<p>Repairing the cause of noise</p>
<p>— (J-43241) Remote Keyless Entry Tester</p>  <p>LEL946A</p>	<p>Used to test key fobs</p>

A
B
C
D
E
F
G
H
I
J
L
M
N
O
P

DLK

PREPARATION

< PREPARATION >

Commercial Service Tool

INFOID:000000001329029

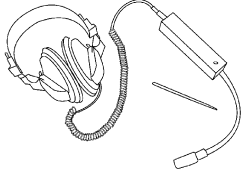
(Kent-Moore No.) Tool name	Description
<p data-bbox="191 317 305 373">(J-39565) Engine ear</p>  <p data-bbox="800 535 865 552">SIA0995E</p>	Locating the noise

HOOD

< ON-VEHICLE REPAIR >

ON-VEHICLE REPAIR

HOOD

Fitting Adjustment

INFOID:000000001329042

SEC. 650

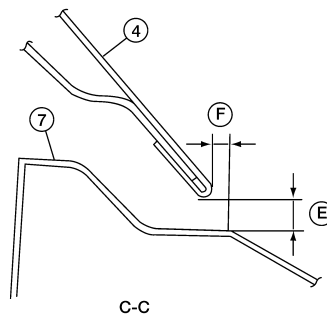
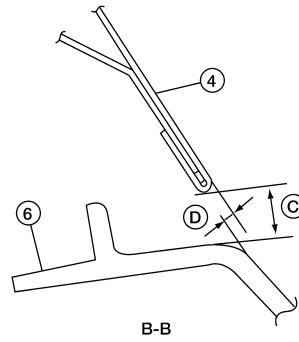
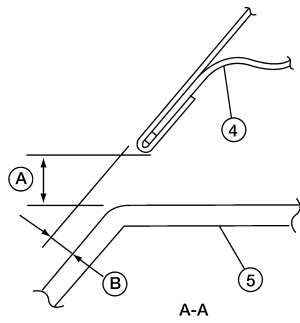
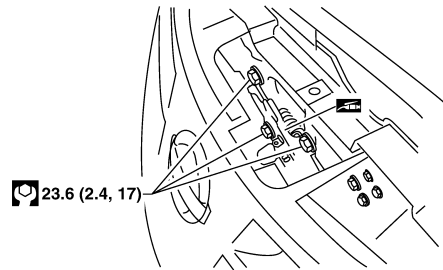
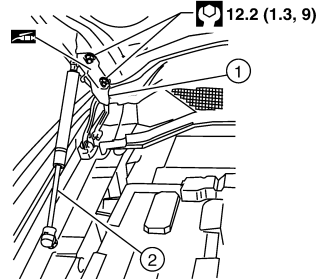
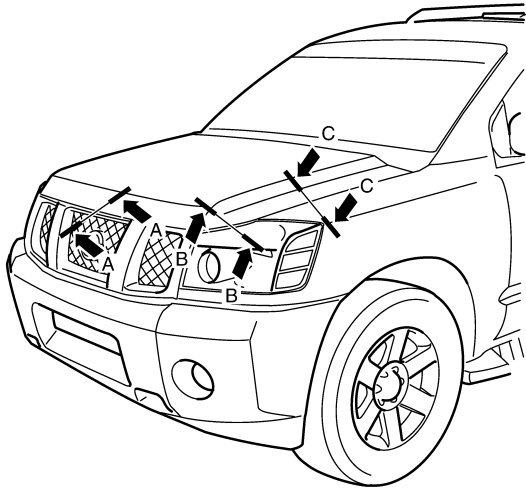

A
B
C
D
E
F
G
H
I
J
L
M
N
O
P

DLK

WIA0883E

HOOD

< ON-VEHICLE REPAIR >

- | | | |
|---------------------|----------------------|-----------------------|
| 1. Hood hinge | 2. Hood stay | 3. Hood lock assembly |
| 4. Hood assembly | 5. Front grille | 6. Headlamp |
| 7. Front fender | A. 8.0 mm (0.315 in) | B. 2.0 mm (0.079 in) |
| C. 8.0mm (0.315 in) | D. 0.8 mm (0.031 in) | E. 5.0 mm (0.197 in) |
| F. 0.0 mm (0.00 in) | | |

CLEARANCE AND SURFACE HEIGHT ADJUSTMENT

1. Remove the front grille. Refer to [EXT-18, "Removal and Installation"](#).
2. Remove the hood lock assembly and adjust the height by rotating the bumper rubber until the hood clearance of hood and fender becomes 1 mm (0.04 in) lower than fitting standard dimension.
3. Temporarily tighten the hood lock, and position it by engaging it with the hood striker. Check the lock and striker for looseness, and tighten the lock bolt to the specified torque.
4. Adjust the clearance and surface height of hood and fender according to the fitting standard dimension by rotating right and left bumper rubbers.

CAUTION:

Adjust right/left gap between hood and each part to the following specification.

Hood and headlamp (B-B) : Less than 8.0 mm

5. Install the front grille. Refer to [EXT-18, "Removal and Installation"](#).

HOOD LOCK ADJUSTMENT

1. Remove the front grille. Refer to [EXT-18, "Removal and Installation"](#).
2. Move the hood lock to the left or right so that striker center is vertically aligned with hood lock center (when viewed from vehicle front).
3. Make sure the secondary latch is properly engaged with the secondary striker with hood's own weight by dropping it from approx. 200 mm (7.87 in) height or by pressing it lightly approx. 3 kg (29 N, 7lb).

CAUTION:

Do not drop the hood from 300 mm (11.81 in) height or higher.

4. After adjusting hood lock, tighten the lock bolts to the specified torque.
5. Install the front grille. Refer to [EXT-18, "Removal and Installation"](#).

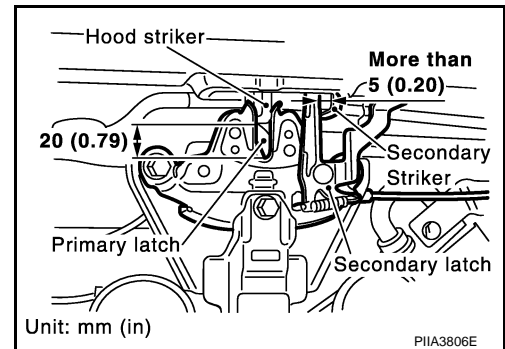

Removal and Installation of Hood Assembly

INFOID:000000001329043

1. Support the hood with a suitable tool.

WARNING:

Body injury may occur if no supporting rod is holding the hood open when removing the damper stay.

2. Remove the hinge nuts from the hood to remove the hood assembly.

CAUTION:

Operate with two workers, because of its heavy weight.

Installation is in the reverse order of removal.

- Adjust the hood. Refer to [DLK-99, "Fitting Adjustment"](#).
- Adjust the hood lock. Refer to [DLK-99, "Fitting Adjustment"](#).

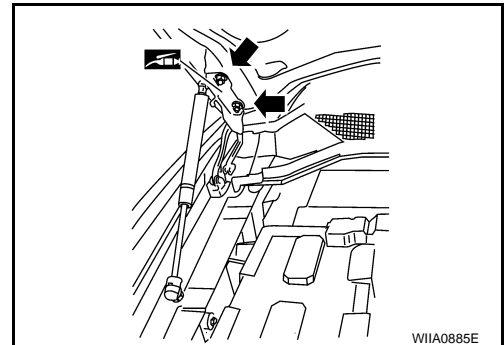

HOOD

< ON-VEHICLE REPAIR >

Removal and Installation of Hood Lock Control

INFOID:000000001329044

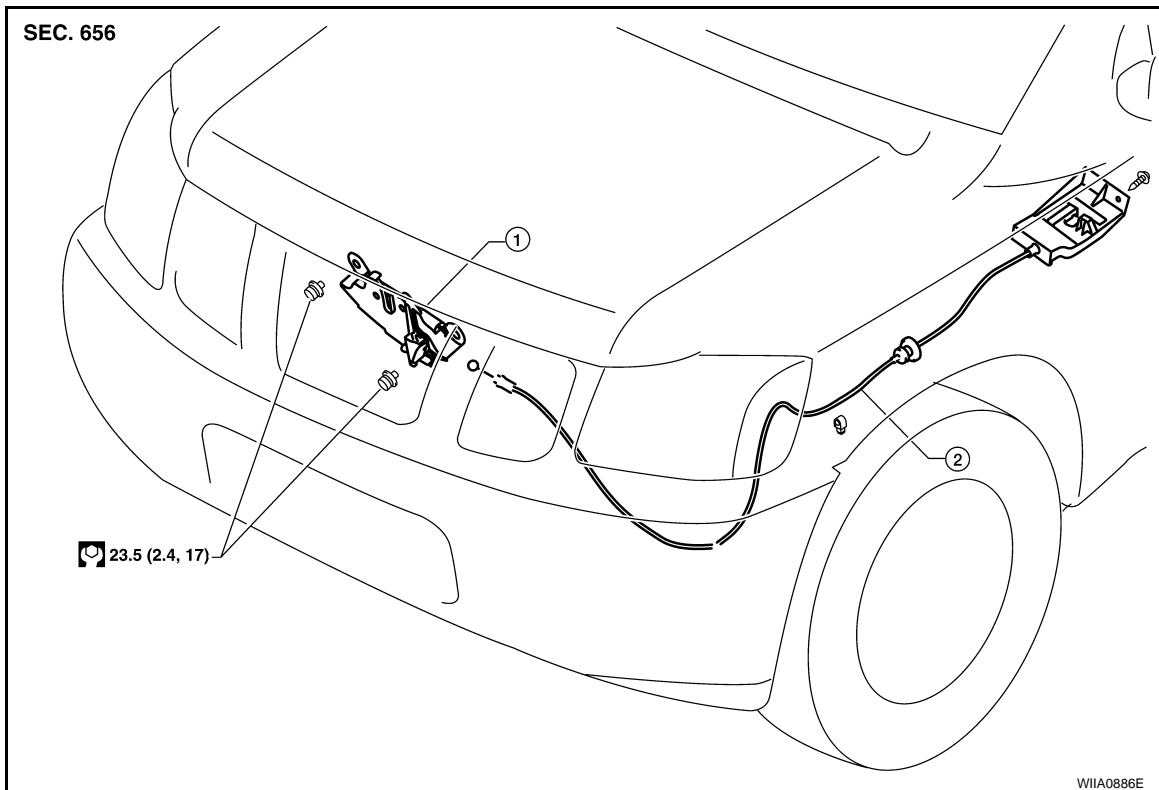

1. Hood lock assembly
2. Hood lock cable

REMOVAL

1. Remove the front grill. Refer to [EXT-18, "Removal and Installation"](#).
2. Remove the front fender protector (LH). Refer to [EXT-21, "Removal and Installation"](#).
3. Disconnect the hood lock cable from the hood lock, and unclip it from the radiator core support upper and hoodledge.
4. Remove the bolt and the hood opener.
5. Remove the grommet from the dash lower, and pull the hood lock cable toward the passenger room.

CAUTION:

While pulling, be careful not to damage the outside of the hood lock cable.

INSTALLATION

1. Pull the hood lock cable through the hole in dash lower panel into the engine room.
Be careful not to bend the cable too much, keeping the radius 100mm (3.94 in) or more.
2. Make sure the cable is not offset from the positioning grommet, and from inside the vehicle, push the grommet into the dash lower hole securely.
3. Apply the sealant around the grommet at (*) mark.

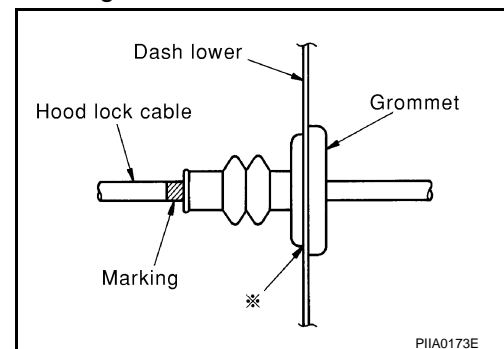

A
B
C
D
E
F
G
H
I
J
L
M
N
O
P

DLK

HOOD

< ON-VEHICLE REPAIR >

4. Install the cable securely to the lock.
5. After installing, check the hood lock adjustment and hood opener operation.

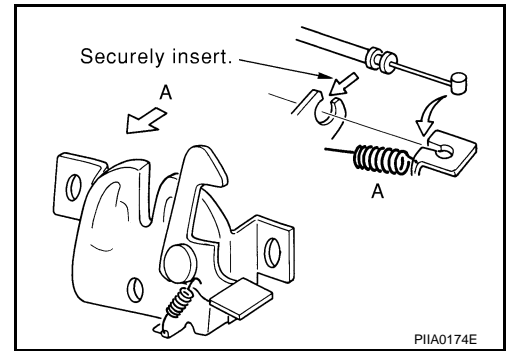

Hood Lock Control Inspection

INFOID:000000001329045

CAUTION:

If the hood lock cable is bent or deformed, replace it.

1. Make sure the secondary latch is properly engaged with the secondary striker with hood's own weight by dropping it from approx. 200 mm (7.87 in) height.
2. While operating the hood opener, carefully make sure the front end of the hood is raised by approx. 20 mm (0.79 in). Also make sure the hood opener returns to the original position.
3. Check the hood lock lubrication condition. If necessary, apply "body grease" to the points shown in the figure.

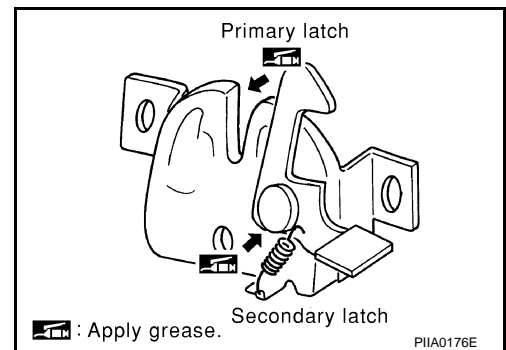
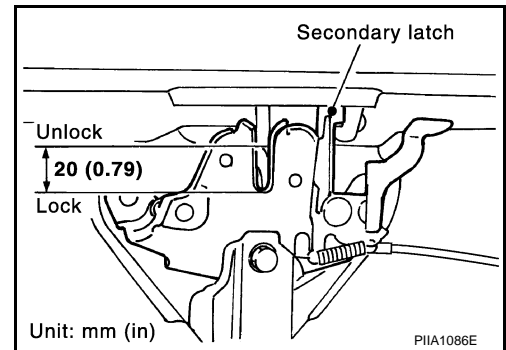

DOOR

< ON-VEHICLE REPAIR >

DOOR

Fitting Adjustment

INFOID:000000001329030

KING CAB

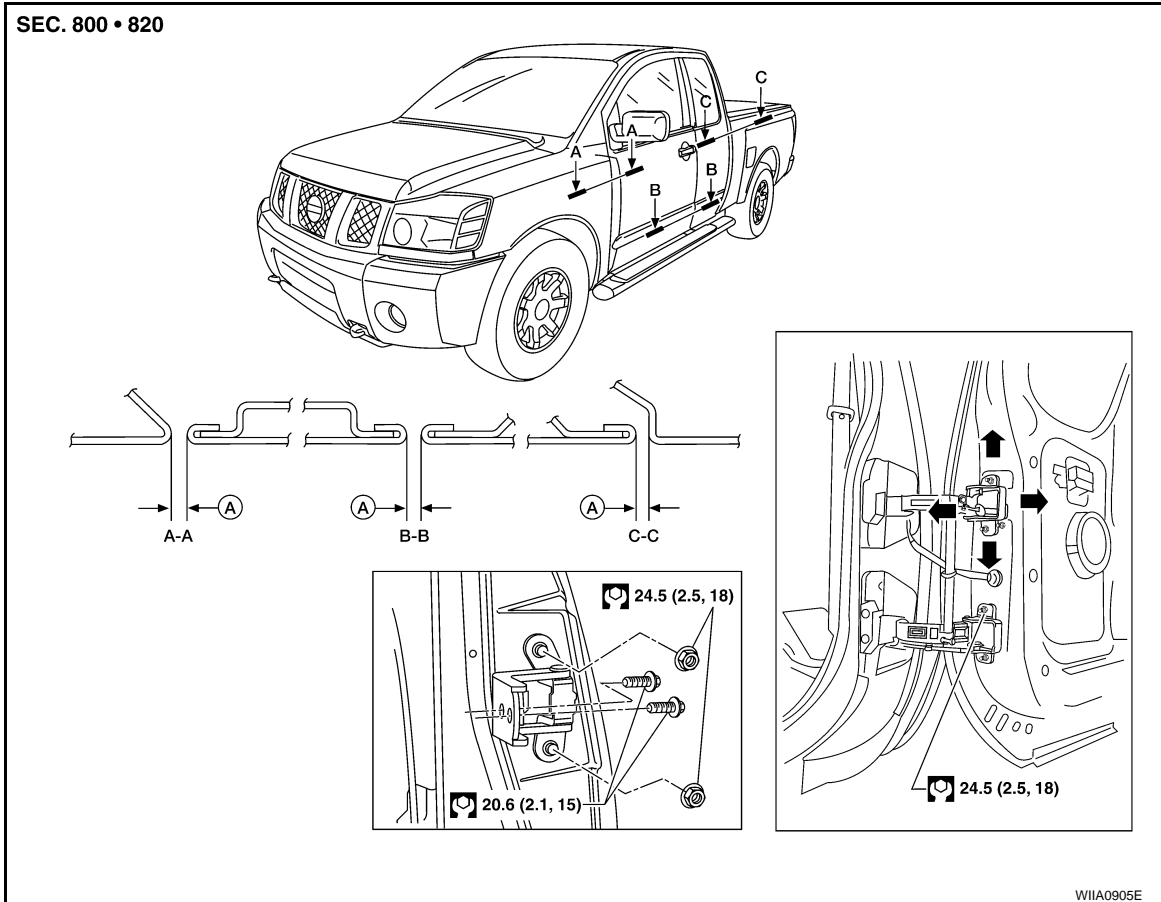

A. $4.5 \pm 1.0 \text{ mm}$ ($0.177 \pm 0.039 \text{ in}$)

A
B
C
D
E
F
G
H
I
J

DLK

L
M
N
O
P

DOOR

< ON-VEHICLE REPAIR >

CREW CAB

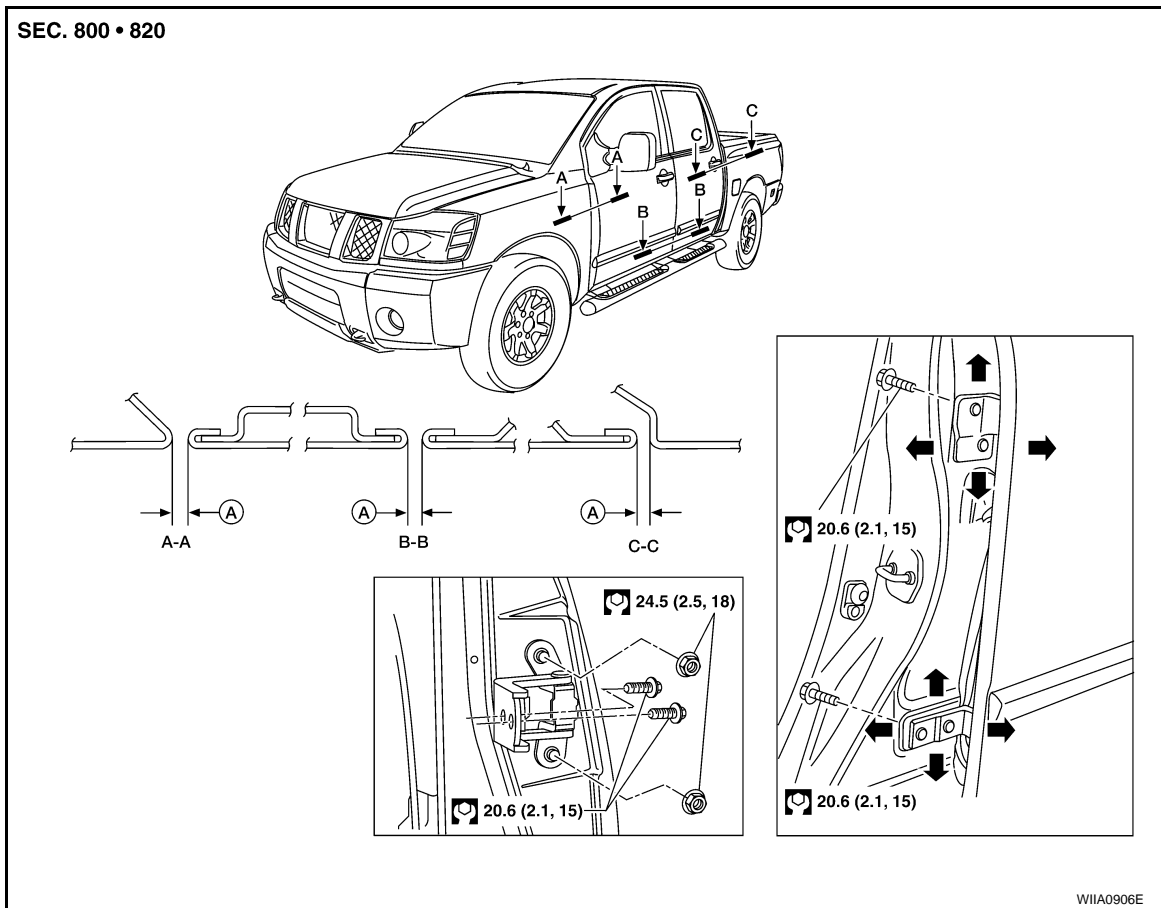

A. 4.5 ± 1.0 mm (0.177 ± 0.039 in)

Front Door

Longitudinal clearance and surface height adjustment at front end

1. Remove the front fender. Refer to [EXT-21, "Removal and Installation"](#).
2. Loosen the hinge bolts. Raise the front door at rear end to adjust.
3. Install the front fender. Refer to [EXT-21, "Removal and Installation"](#).

Rear Door Crew Cab

Longitudinal clearance and surface height adjustment at rear end

1. Remove the center pillar upper garnish. Refer to [INT-14, "Removal and Installation"](#).
2. Accessing from inside the vehicle, loosen the nuts. Open the rear door, and raise the rear door at rear end to adjust.
3. Install the center pillar upper garnish. Refer to [INT-14, "Removal and Installation"](#).

Rear Door King Cab

Longitudinal clearance and surface height adjustment at front end

1. With the door open, support and loosen the hinge to door nuts.
2. Adjust the door position as necessary.
3. Tighten the nuts to specification.

Striker adjustment

DOOR

< ON-VEHICLE REPAIR >

1. Adjust the striker so that it becomes parallel with the lock insertion direction.

Striker Bolts

:16.6 N·m (1.7 kg-m, 12 ft-lb)

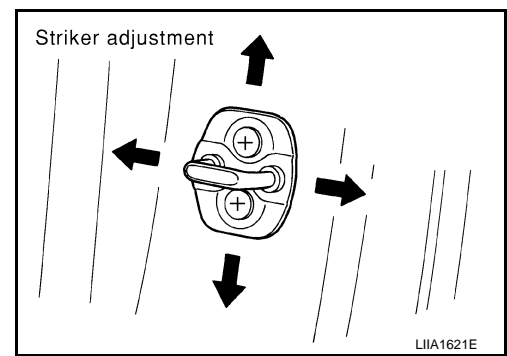

Removal and Installation

INFOID:000000001329031

KING CAB

Front Door

CAUTION:

- When removing and installing the door assembly, support the door with a jack and shop cloth to protect the door and body.
 - When removing and installing door assembly, be sure to carry out the fitting adjustment.
 - Check the hinge rotating part for poor lubrication. If necessary, apply body grease.
1. Remove the front door lock assembly. Refer to [DLK-108, "Removal and Installation"](#).
 2. Remove the door harness.
 3. Remove the check link cover.
 4. Remove the check link bolt from the hinge pillar.

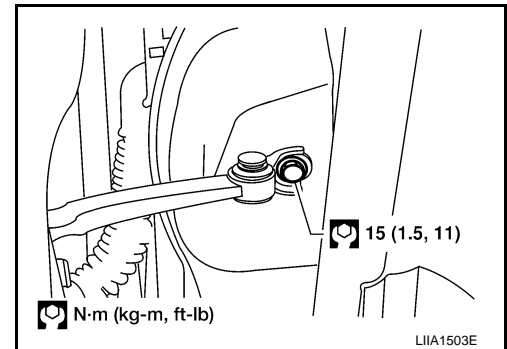

5. Remove the door-side hinge nuts and bolts, and remove the door assembly.

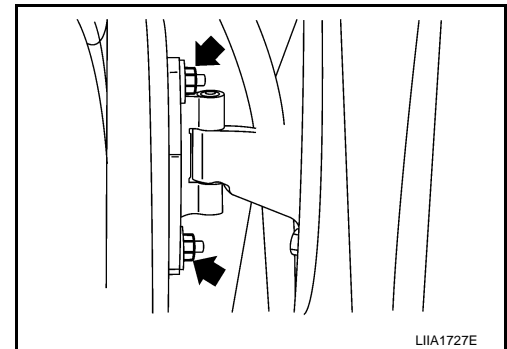

Installation is in the reverse order of removal.

- Align the front door. Refer to [DLK-103, "Fitting Adjustment"](#).

Rear Door

CAUTION:

- When removing and installing the door assembly, support the door with a jack and shop cloth to protect the door and body.
 - When removing and installing door assembly, be sure to carry out the fitting adjustment.
 - Check the hinge rotating part for poor lubrication. If necessary, apply body grease.
1. Remove the door glass. Refer to [GW-23, "Removal"](#).

A
B
C
D
E
F
G
H
I
J
DLK
L
M
N
O
P

DOOR

< ON-VEHICLE REPAIR >

2. Remove the speaker.
3. Remove the door handles and latch assembly. Refer to [DLK-111, "Component Structure"](#).
4. Remove the check link.
5. Remove the wire harness.
6. Remove the door assembly.

Installation is in the reverse order of removal.

- Align the rear door. Refer to [DLK-103, "Fitting Adjustment"](#).

Door hinge nuts : 24.5 N·m (2.5 kg-m, 18 ft-lb)
Check link bolt : 5.1 N·m (0.52 kg-m, 45 in-lb)

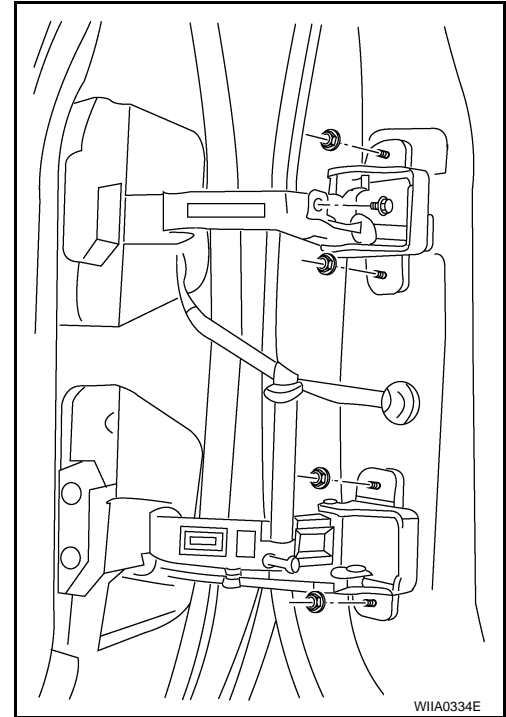

CREW CAB

CAUTION:

- When removing and installing the door assembly, support the door with a jack and shop cloth to protect the door and body.
- When removing and installing door assembly, be sure to carry out the fitting adjustment.
- Check the hinge rotating part for poor lubrication. If necessary, apply body grease.

1. Remove the rear door lock assembly. Refer to [DLK-112, "Removal and Installation"](#).
2. Remove the door harness.
3. Remove the check link cover.
4. Remove the check link bolt from the hinge pillar.

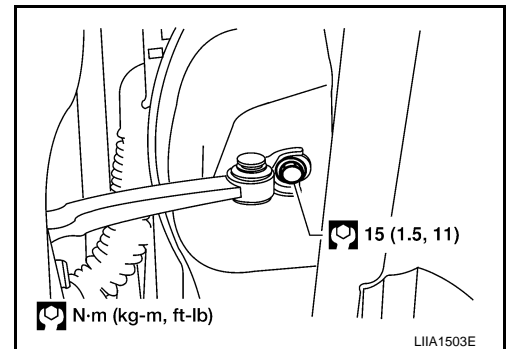

DOOR

< ON-VEHICLE REPAIR >

5. Remove the door-side hinge nuts and bolts, and the door assembly.

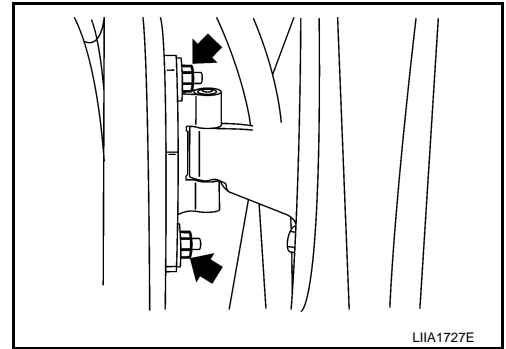

Installation is in the reverse order of removal.

- Align the front door. Refer to [DLK-103, "Fitting Adjustment"](#).

A
B
C
D
E
F
G
H
I
J
L
M
N
O
P

DLK

FRONT DOOR LOCK

< ON-VEHICLE REPAIR > FRONT DOOR LOCK

Component Structure

INFOID:000000001572419

SEC. 805

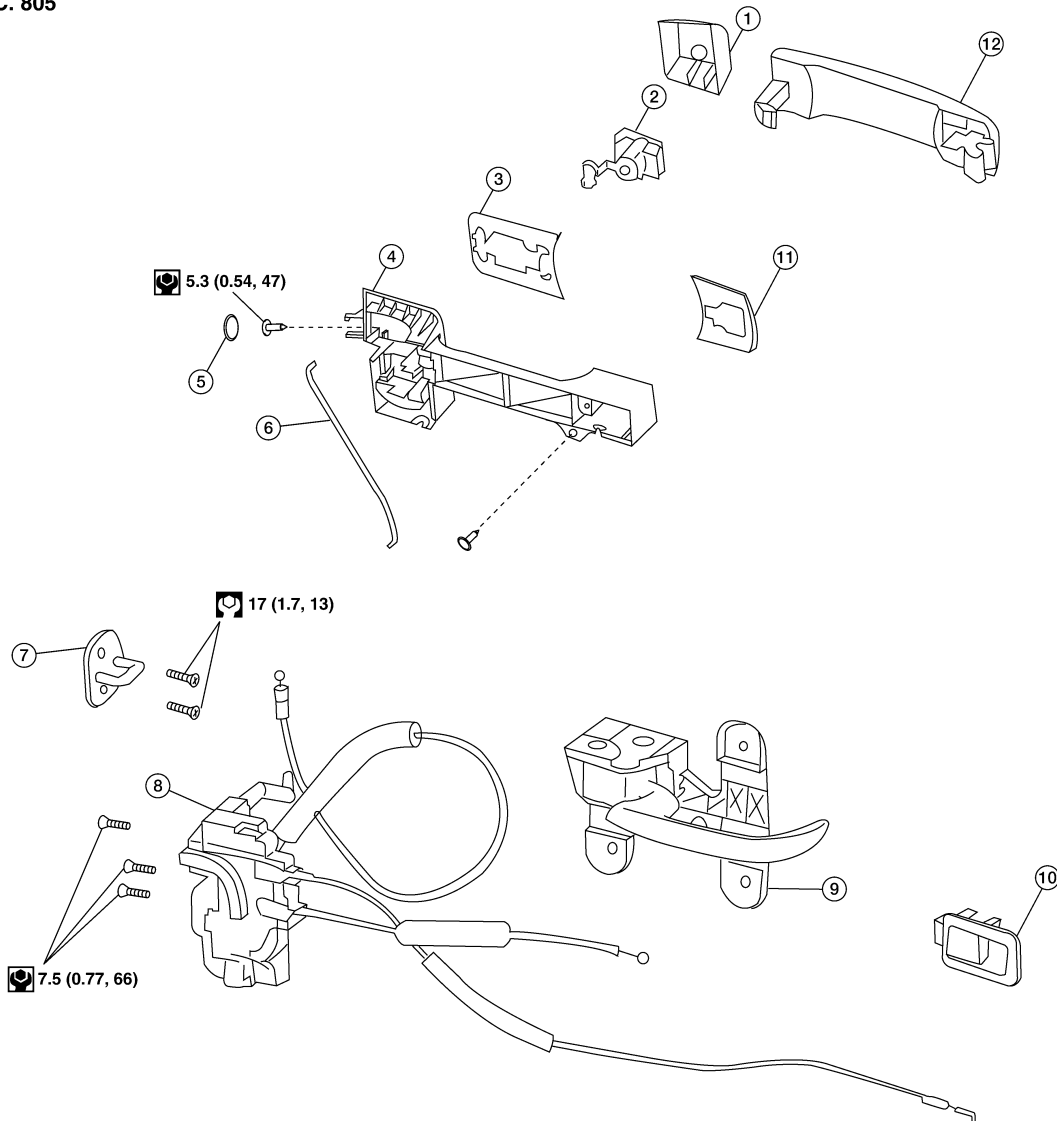

ALKIA0898GB

- | | | |
|--|---|--|
| 1. Door key cylinder assembly (Driver side) Outside handle escutcheon (Passenger side) | 2. Key cylinder assembly (Driver side only) | 3. Rear gasket |
| 4. Outside handle bracket | 5. Grommet | 6. Key cylinder rod (Driver side only) |
| 7. Front door striker | 8. Door lock assembly | 9. Inside handle assembly |
| 10. Inside door lock lever | 11. Front gasket | 12. Outside handle assembly |

Removal and Installation

INFOID:000000001572420

REMOVAL

1. Remove the front door window regulator. Refer to [GW-18, "Removal and Installation"](#).
2. Remove the front door window rear glass run.

FRONT DOOR LOCK

< ON-VEHICLE REPAIR >

3. Remove the door side grommet, and the bolt (TORX T30) from the grommet hole.

Torx bolt

5.3 N·m (0.54 kg-m, 47 in-lb)

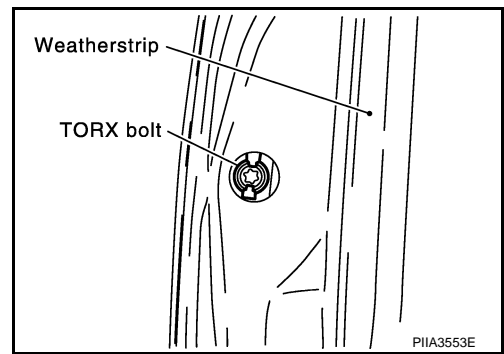

4. While pulling the outside handle (1), remove the door key cylinder assembly or outside handle escutcheon (2).

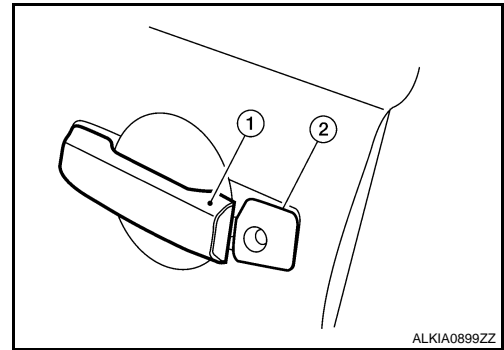

5. Separate the key cylinder rod from the door key cylinder assembly (if equipped).
6. While pulling the outside handle, slide it toward rear of vehicle to remove as shown.

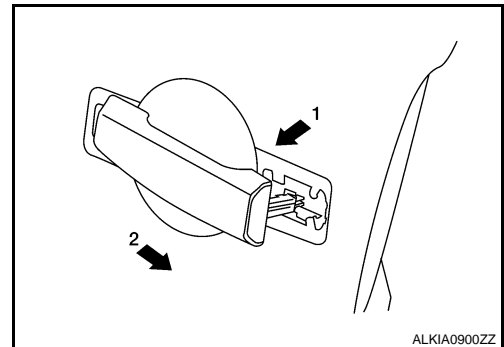

7. Remove the front gasket (1) and rear gasket (2).

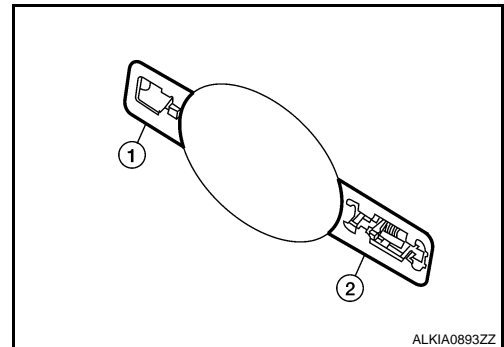

A
B
C
D
E
F
G
H
I
J
DLK
L
M
N
O
P

FRONT DOOR LOCK

< ON-VEHICLE REPAIR >

8. Remove the TORX bolts (T30), and separate the door lock assembly from the door.

Door lock assembly bolts 7.5 N-m (0.77 kg-m, 66 in-lb)

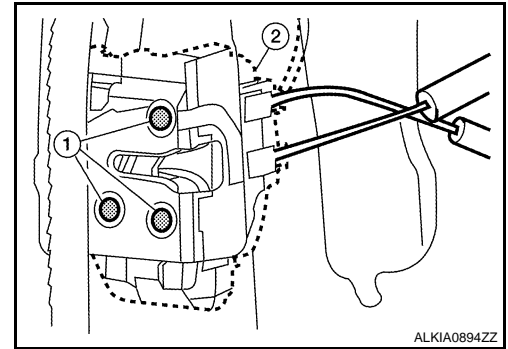

9. While pulling the outside handle bracket, slide it toward the front of the vehicle to remove it and the door lock assembly as shown.

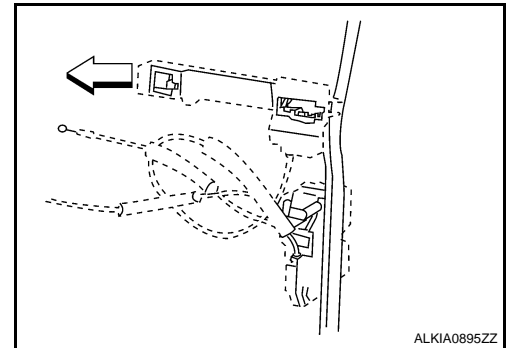

10. Disconnect the door lock actuator electrical connector.
11. Separate the outside handle cable connection (1) from the outside handle bracket.

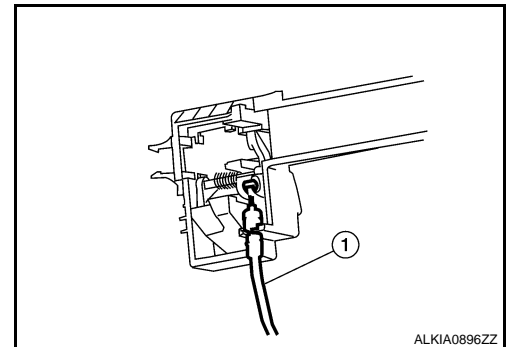

INSTALLATION

Installation is in the reverse order of removal.

CAUTION:

To install the key cylinder rod, be sure to rotate the key cylinder rod holder until a click is felt.

Disassembly and Assembly

INFOID:000000001572421

DOOR KEY CYLINDER ASSEMBLY

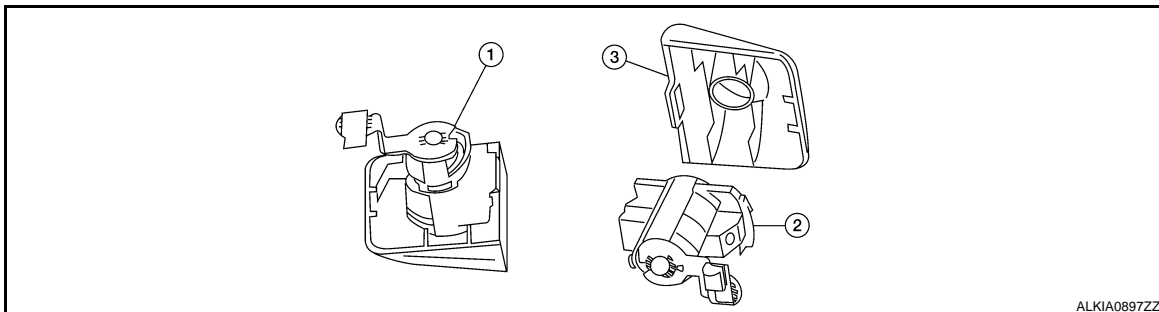

1. Door key cylinder assembly

2. Key cylinder assembly

3. Door key cylinder escutcheon

Release the door key cylinder escutcheon pawls to remove the door key cylinder.

REAR DOOR LOCK

< ON-VEHICLE REPAIR >

REAR DOOR LOCK

Component Structure

INFOID:000000001329037

KING CAB

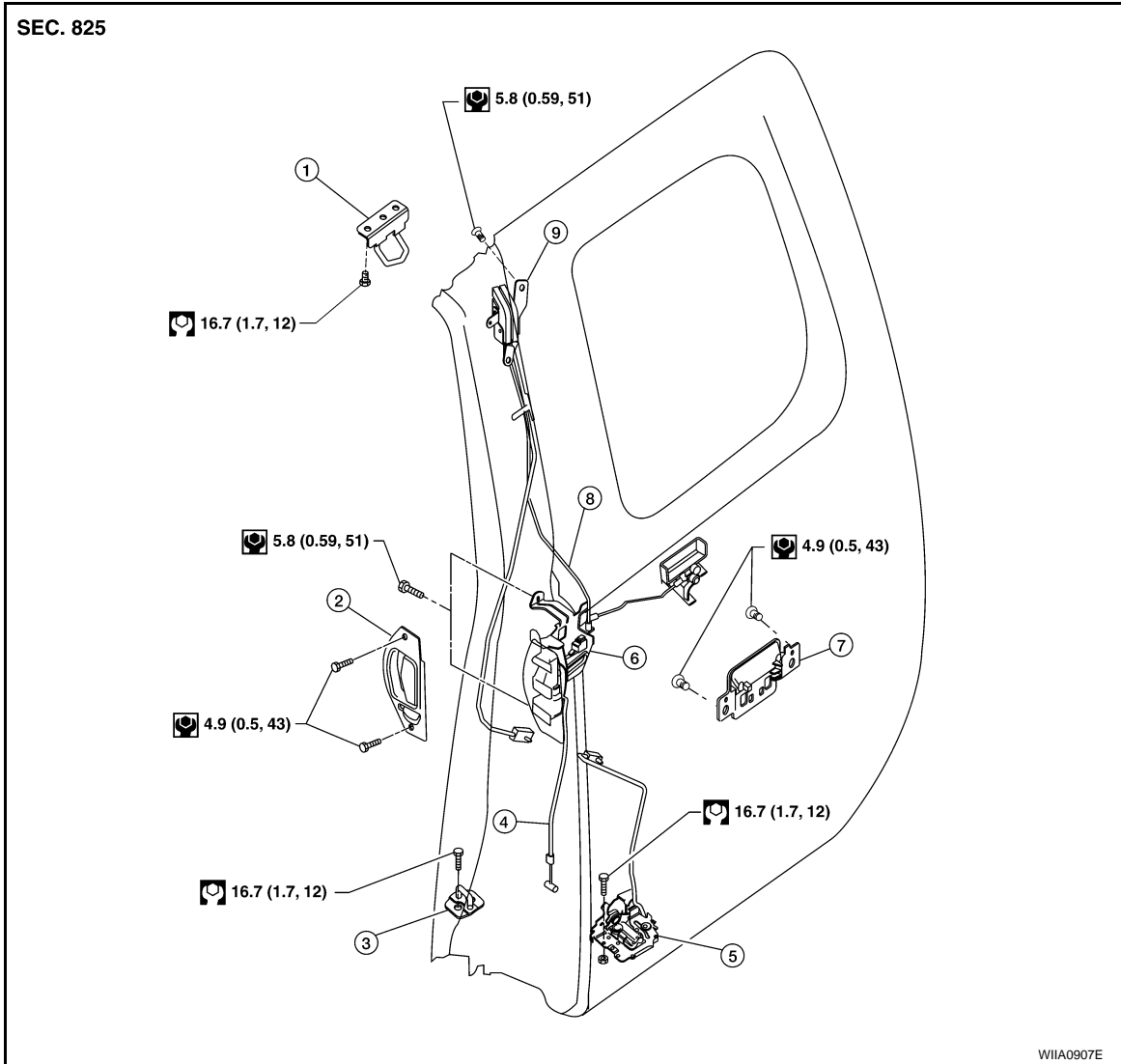

- | | | |
|---------------------------------|--------------------------|---------------------------------|
| 1. Rear upper door lock striker | 2. Rear door handle | 3. Rear lower door lock striker |
| 4. Lower latch cable | 5. Rear lower door latch | 6. Rear door lock assembly |
| 7. Rear inside door handle | 8. Upper latch cable | 9. Rear upper door latch |

DLK-111

A
B
C
D
E
F
G
H
I
J
K
L
M
N
O
P

DLK

REAR DOOR LOCK

< ON-VEHICLE REPAIR >

CREW CAB

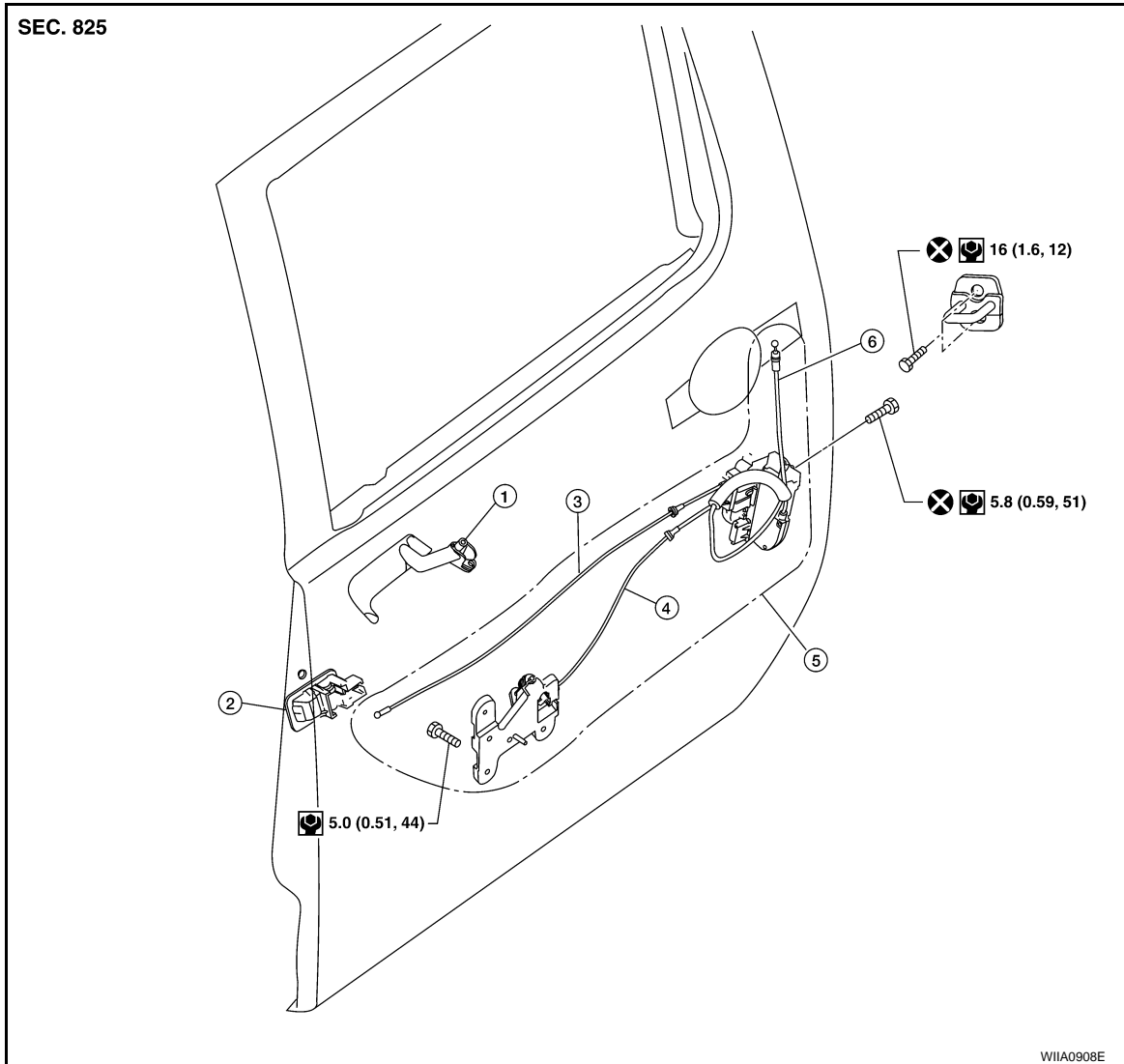

- | | | |
|----------------------------|---|-------------------------|
| 1. Rear inside door handle | 2. Rear door lock knob | 3. Lock knob cable |
| 4. Inside handle cable | 5. Rear door lock/remote control assembly | 6. Outside handle cable |

Removal and Installation

INFOID:000000001329038

REMOVAL

1. Remove the rear door window and rear door module assembly. Refer to [GW-21, "Rear Door Glass"](#).
2. Remove the door side grommet and the bolt (TORX T30) from the grommet hole.

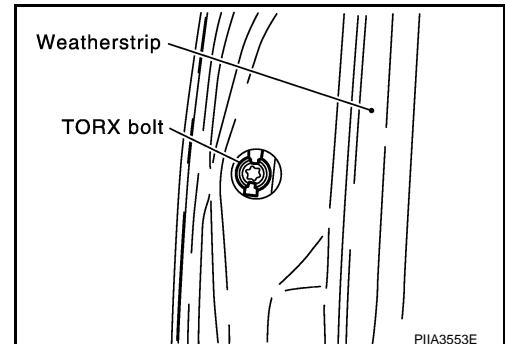

REAR DOOR LOCK

< ON-VEHICLE REPAIR >

3. While pulling the outside handle, remove the door handle escutcheon.

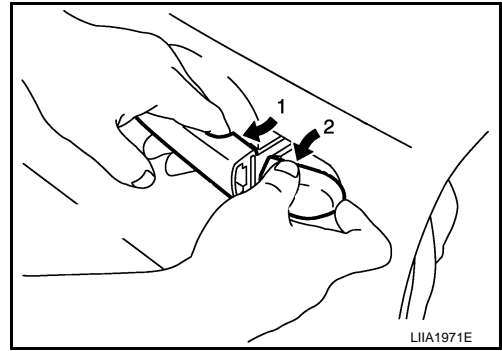

4. While pulling the outside handle, slide it toward the rear of vehicle to remove.

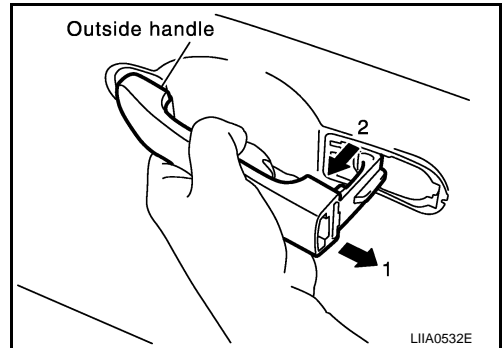

5. Remove the front and rear gaskets.

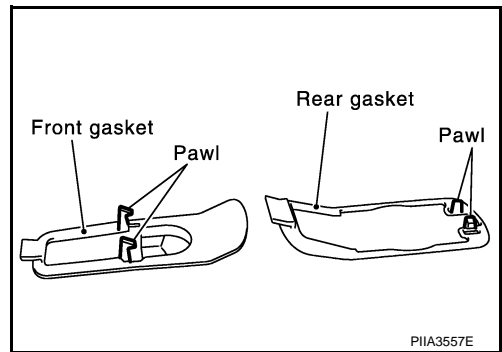

6. Remove the inside handle screws.
7. Remove the TORX bolts (T30), remove the door lock assembly.

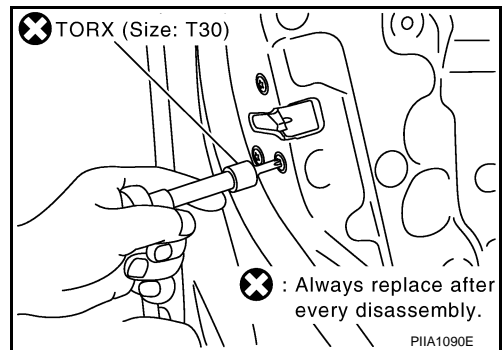

A
B
C
D
E
F
G
H
I
J
DLK
L
M
N
O
P

REAR DOOR LOCK

< ON-VEHICLE REPAIR >

8. While pulling outside handle bracket, slide toward rear of vehicle to remove outside handle bracket and door lock assembly.

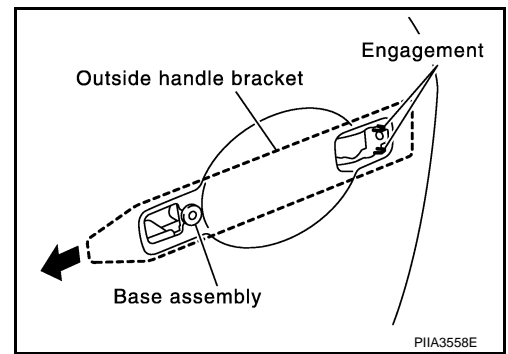

9. Disconnect the outside handle cable.

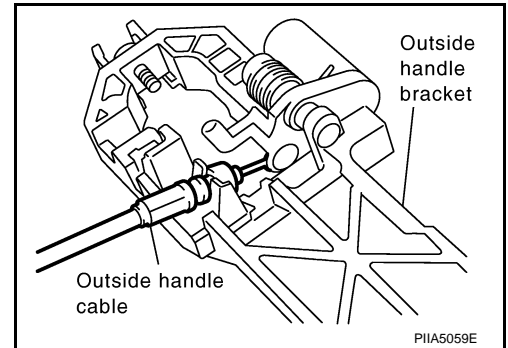

INSTALLATION

Installation is in the reverse order of removal.

TAIL GATE

< ON-VEHICLE REPAIR >

TAIL GATE

Removal and Installation

INFOID:000000001329039

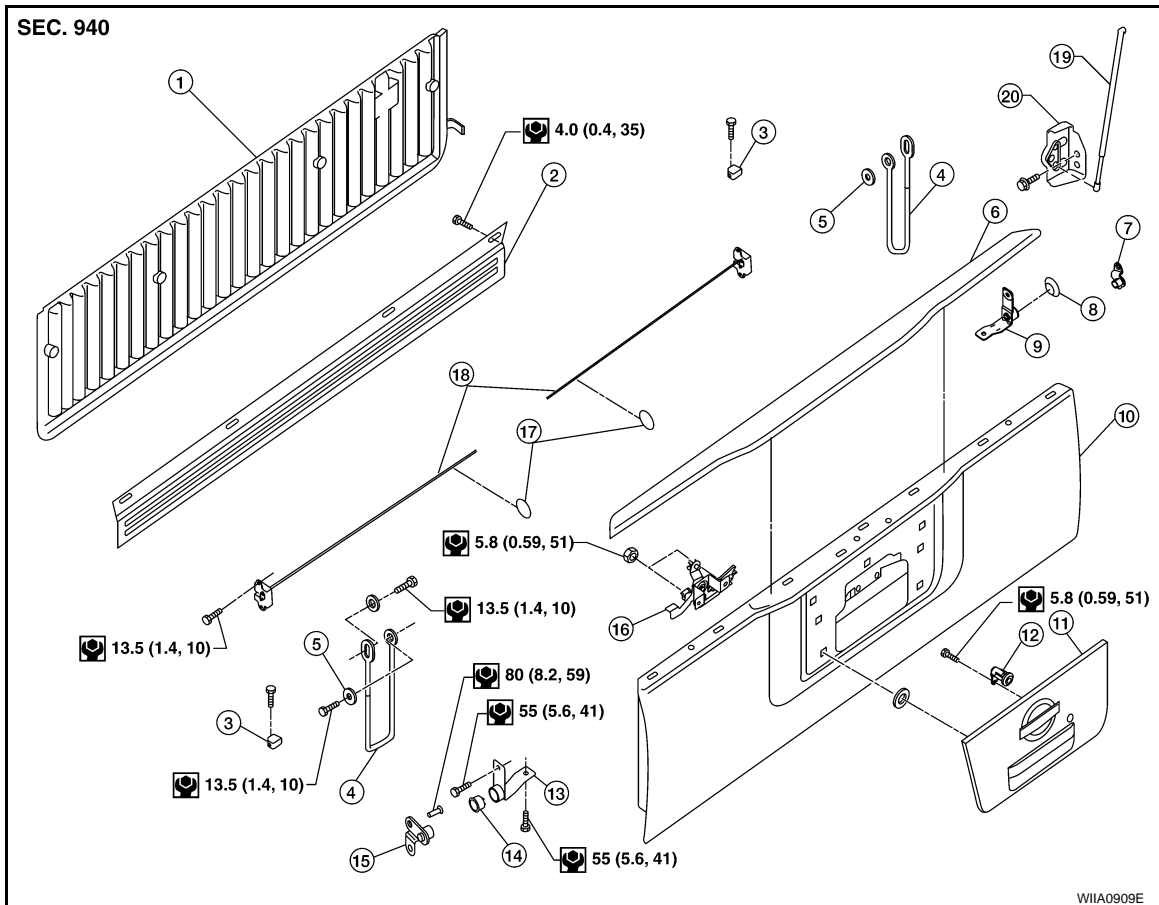

- | | | |
|--|--------------------------|--|
| 1. Rear gate liner cover (if equipped) | 2. Rear gate inner panel | 3. Rear gate rubber bumper |
| 4. Rear gate stay assembly | 5. Washer | 6. Rear gate cover |
| 7. Rear gate hinge assembly (RH), body side | 8. Rear gate ring (RH) | 9. Rear gate hinge assembly (RH), gate side |
| 10. Rear gate | 11. Rear gate handle | 12. Rear gate lock cylinder |
| 13. Rear gate hinge assembly (LH), gate side | 14. Rear gate ring (LH) | 15. Rear gate hinge assembly (LH), body side |
| 16. Rear gate control assembly | 17. Rubber bumper | 18. Rear gate latch assembly (RH & LH) |
| 19. Gas stay | 20. Gas stay bracket | |

GAS STAY

Removal

WARNING:

The gas stay is under high pressure. Remove the gas stay only with the tailgate fully closed. Injury may result if the gas stay is removed when the tailgate is open.

1. Remove the RH rear combination lamp assembly. Refer to [EXL-102. "Removal and Installation"](#).

TAIL GATE

< ON-VEHICLE REPAIR >

2. Remove the gas stay.

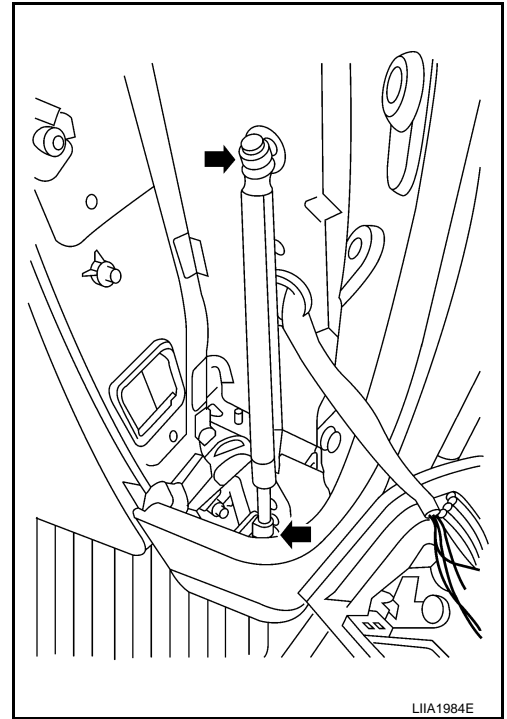

Installation

Installation is in the reverse order of removal.