

# SECTION HAC

## HEATER & AIR CONDITIONING CONTROL SYSTEM

### CONTENTS

<b>AUTOMATIC AIR CONDITIONER</b>		
<b>BASIC INSPECTION</b> .....	6	
<b>DIAGNOSIS AND REPAIR WORKFLOW</b> .....	6	
How to Perform Trouble Diagnosis For Quick And Accurate Repair .....	6	
<b>INSPECTION AND ADJUSTMENT</b> .....	7	
Operational Check .....	7	
<b>FUNCTION DIAGNOSIS</b> .....	9	
<b>FUNCTION INFORMATION</b> .....	9	
Component Part Location .....	9	
Symptom Table .....	11	
<b>REFRIGERATION SYSTEM</b> .....	12	
Refrigerant Cycle .....	12	
Refrigerant System Protection .....	12	
<b>AUTOMATIC AIR CONDITIONER SYSTEM</b> ....	13	
Control System Diagram .....	13	
Control System Description .....	13	
Discharge Air Flow .....	15	
Switches And Their Control Function .....	16	
<b>CAN COMMUNICATION SYSTEM</b> .....	17	
System Description .....	17	
<b>DIAGNOSIS SYSTEM (HVAC)</b> .....	18	
CONSULT-III Function (HVAC) .....	18	
<b>DIAGNOSIS SYSTEM (BCM)</b> .....	20	
CONSULT-III Function (BCM) .....	20	
<b>SELF-DIAGNOSIS FUNCTION</b> .....	21	
Front Air Control Self-Diagnosis .....	21	
Front Air Control Self-Diagnosis Code Chart .....	21	
<b>COMPONENT DIAGNOSIS</b> .....	22	
<b>MODE DOOR MOTOR</b> .....	22	
System Description .....	22	
Mode Door Motor Component Function Check .....	23	
Mode Door Motor Diagnosis Procedure .....	24	
<b>AIR MIX DOOR MOTOR</b> .....	28	
System Description .....	28	
Air Mix Door Motor Component Function Check .....	29	
Air Mix Door Motor (Driver) Diagnosis Procedure .....	30	
Air Mix Door Motor (Passenger) Diagnosis Procedure .....	33	
<b>INTAKE DOOR MOTOR</b> .....	37	
System Description .....	37	
Intake Door Motor Component Function Check .....	38	
Intake Door Motor Diagnosis Procedure .....	39	
<b>DEFROSTER DOOR MOTOR CIRCUIT</b> .....	41	
System Description .....	41	
Defroster Door Motor Component Function Check .....	41	
Defroster Door Motor Diagnosis Procedure .....	42	
<b>BLOWER MOTOR CONTROL SYSTEM</b> .....	46	
System Description .....	46	
Front Blower Motor Component Function Check .....	47	
Front Blower Motor Diagnosis Procedure .....	48	
Front Blower Motor Component Inspection .....	51	
<b>MAGNET CLUTCH</b> .....	53	
System Description .....	53	
Magnet Clutch Component Function Check .....	53	
Magnet Clutch Diagnosis Procedure .....	54	
<b>WATER VALVE CIRCUIT</b> .....	58	
Description .....	58	
Water Valve Diagnosis Procedure .....	58	
<b>AMBIENT SENSOR</b> .....	60	
Component Description .....	60	
Ambient Sensor Diagnosis Procedure .....	60	
Ambient Sensor Component Inspection .....	61	

A  
B  
C  
D  
E  
F  
G  
H  
HAC  
J  
K  
L  
M  
N  
O  
P

<b>IN-VEHICLE SENSOR</b> .....	<b>63</b>	<b>DIAGNOSIS AND REPAIR WORKFLOW</b> .....	<b>100</b>
Component Description .....	63	How to Perform Trouble Diagnosis For Quick And	
In-Vehicle Sensor Diagnosis Procedure .....	63	Accurate Repair .....	100
In-Vehicle Sensor Component Inspection .....	65	<b>INSPECTION AND ADJUSTMENT</b> .....	<b>101</b>
<b>OPTICAL SENSOR</b> .....	<b>66</b>	Operational Check .....	101
Component Description .....	66	<b>FUNCTION DIAGNOSIS</b> .....	<b>103</b>
Optical Sensor Diagnosis Procedure .....	66	<b>MANUAL A/C IDENTIFICATION TABLE</b> .....	<b>103</b>
<b>INTAKE SENSOR</b> .....	<b>68</b>	Application Table .....	103
System Description .....	68	<b>FUNCTION INFORMATION</b> .....	<b>104</b>
Intake Sensor Diagnosis Procedure .....	68	Component Part Location .....	104
Intake Sensor Component Inspection .....	69	Symptom Table .....	106
<b>POWER SUPPLY AND GROUND CIRCUIT</b>		<b>REFRIGERATION SYSTEM</b> .....	<b>107</b>
<b>FOR CONTROLLER</b> .....	<b>70</b>	Refrigerant Cycle .....	107
Component Description .....	70	Refrigerant System Protection .....	107
Front Air Control Component Function Check .....	70	<b>MANUAL AIR CONDITIONER SYSTEM</b> .....	<b>108</b>
Front Air Control Power and Ground Diagnosis		Control System Diagram .....	108
Procedure .....	71	Control System Description .....	108
<b>ECU DIAGNOSIS</b> .....	<b>72</b>	Discharge Air Flow .....	110
<b>AIR CONDITIONER CONTROL</b> .....	<b>72</b>	Switches And Their Control Function .....	110
Front Air Control Terminals Reference Values .....	72	<b>CAN COMMUNICATION SYSTEM</b> .....	<b>112</b>
Wiring Diagram .....	74	System Description .....	112
<b>SYMPTOM DIAGNOSIS</b> .....	<b>83</b>	<b>DIAGNOSIS SYSTEM (HVAC)</b> .....	<b>113</b>
<b>AIR CONDITIONER CONTROL</b> .....	<b>83</b>	CONSULT-III Function (HVAC) .....	113
Symptom Matrix Chart .....	83	<b>DIAGNOSIS SYSTEM (BCM)</b> .....	<b>114</b>
<b>INSUFFICIENT COOLING</b> .....	<b>84</b>	CONSULT-III Function (BCM) .....	114
Component Function Check .....	84	<b>SELF-DIAGNOSIS FUNCTION</b> .....	<b>115</b>
Performance Test Diagnoses .....	85	Front Air Control Self-Diagnosis .....	115
Performance Chart .....	87	Front Air Control Self-Diagnosis Code Chart .....	115
Test Reading .....	88	<b>COMPONENT DIAGNOSIS</b> .....	<b>116</b>
Trouble Diagnoses for Unusual Pressure .....	89	<b>MANUAL A/C IDENTIFICATION TABLE</b> .....	<b>116</b>
<b>INSUFFICIENT HEATING</b> .....	<b>92</b>	Application Table .....	116
Component Function Check .....	92	<b>MODE DOOR MOTOR</b> .....	<b>117</b>
<b>NOISE</b> .....	<b>94</b>	System Description .....	117
Component Function Check .....	94	Mode Door Motor Component Function Check ...	117
<b>MEMORY FUNCTION DOES NOT OPERATE..</b>	<b>96</b>	Mode Door Motor Diagnosis Procedure .....	118
Memory Function Check .....	96	<b>AIR MIX DOOR MOTOR</b> .....	<b>122</b>
<b>PRECAUTION</b> .....	<b>97</b>	System Description .....	122
<b>PRECAUTIONS</b> .....	<b>97</b>	Air Mix Door Motor Component Function Check .	122
Supplemental Restraint System (SRS) "AIR BAG"		Air Mix Door Motor Diagnosis Procedure .....	123
and "SEAT BELT PRE-TENSIONER" .....	97	<b>INTAKE DOOR MOTOR</b> .....	<b>127</b>
Working with HFC-134a (R-134a) .....	97	System Description .....	127
Precaution for Service Equipment .....	98	Intake Door Motor Component Function Check ...	127
<b>MANUAL A/C (TYPE 1)</b>		Intake Door Motor Diagnosis Procedure .....	128
<b>BASIC INSPECTION</b> .....	<b>99</b>	<b>DEFROSTER DOOR MOTOR CIRCUIT</b> .....	<b>130</b>
<b>MANUAL A/C IDENTIFICATION TABLE</b> .....	<b>99</b>	System Description .....	130
Application Table .....	99		

Defroster Door Motor Component Function Check .. 130	<b>NOISE</b> ..... 177	
Defroster Door Motor Diagnosis Procedure ..... 131	Component Function Check ..... 177	A
<b>BLOWER MOTOR CONTROL SYSTEM</b> ..... 135	<b>PRECAUTION</b> ..... 179	
System Description ..... 135	<b>PRECAUTIONS</b> ..... 179	B
Front Blower Motor Component Function Check .. 135	Supplemental Restraint System (SRS) "AIR BAG" and "SEAT BELT PRE-TENSIONER" ..... 179	
Front Blower Motor Diagnosis Procedure ..... 136	Working with HFC-134a (R-134a) ..... 179	C
Front Blower Motor Component Inspection ..... 139	Precaution for Service Equipment ..... 180	
<b>MAGNET CLUTCH</b> ..... 141	<b>MANUAL A/C (TYPE 2)</b>	
System Description ..... 141		D
Magnet Clutch Component Function Check ..... 141	<b>BASIC INSPECTION</b> ..... 181	
Magnet Clutch Diagnosis Procedure ..... 142		
<b>WATER VALVE CIRCUIT</b> ..... 146	<b>MANUAL A/C IDENTIFICATION TABLE</b> ..... 181	E
Description ..... 146	Application Table ..... 181	
Water Valve Diagnosis Procedure ..... 146	<b>DIAGNOSIS AND REPAIR WORKFLOW</b> ..... 182	
<b>AMBIENT SENSOR</b> ..... 148	How to Perform Trouble Diagnosis For Quick And Accurate Repair ..... 182	F
Component Description ..... 148		
Ambient Sensor Diagnosis Procedure ..... 148	<b>INSPECTION AND ADJUSTMENT</b> ..... 183	
Ambient Sensor Component Inspection ..... 149	Operational Check ..... 183	G
<b>INTAKE SENSOR</b> ..... 151	<b>FUNCTION DIAGNOSIS</b> ..... 185	
System Description ..... 151		
Intake Sensor Diagnosis Procedure ..... 151	<b>MANUAL A/C IDENTIFICATION TABLE</b> ..... 185	H
Intake Sensor Component Inspection ..... 152	Application Table ..... 185	
<b>POWER SUPPLY AND GROUND CIRCUIT FOR CONTROLLER</b> ..... 153	<b>FUNCTION INFORMATION</b> ..... 186	HAC
Component Description ..... 153	Component Part Location ..... 186	
Front Air Control Component Function Check ..... 153	Symptom Table ..... 188	
Front Air Control Power and Ground Diagnosis Procedure ..... 154	<b>REFRIGERATION SYSTEM</b> ..... 189	J
<b>ECU DIAGNOSIS</b> ..... 155	Refrigerant Cycle ..... 189	
	Refrigerant System Protection ..... 189	
<b>MANUAL A/C IDENTIFICATION TABLE</b> ..... 155	<b>MANUAL AIR CONDITIONER SYSTEM</b> ..... 190	K
Application Table ..... 155	Control System Diagram ..... 190	
<b>AIR CONDITIONER CONTROL</b> ..... 156	Control System Description ..... 190	L
Front Air Control Terminals Reference Values .... 156	Discharge Air Flow ..... 191	
Wiring Diagram ..... 158	Switches And Their Control Function ..... 192	
<b>SYMPTOM DIAGNOSIS</b> ..... 165	<b>CAN COMMUNICATION SYSTEM</b> ..... 194	M
	System Description ..... 194	
<b>MANUAL A/C IDENTIFICATION TABLE</b> ..... 165	<b>DIAGNOSIS SYSTEM (BCM)</b> ..... 195	N
Application Table ..... 165	CONSULT-III Function (BCM) ..... 195	
<b>AIR CONDITIONER CONTROL</b> ..... 166	<b>COMPONENT DIAGNOSIS</b> ..... 196	
Symptom Matrix Chart ..... 166		O
<b>INSUFFICIENT COOLING</b> ..... 167	<b>MANUAL A/C IDENTIFICATION TABLE</b> ..... 196	
Component Function Check ..... 167	Application Table ..... 196	
Performance Test Diagnoses ..... 168	<b>MODE DOOR MOTOR</b> ..... 197	P
Performance Chart ..... 170	System Description ..... 197	
Test Reading ..... 171	Mode Door Motor Component Function Check .... 197	
Trouble Diagnoses for Unusual Pressure ..... 172	Mode Door Motor Diagnosis Procedure ..... 198	
<b>INSUFFICIENT HEATING</b> ..... 175	<b>AIR MIX DOOR MOTOR</b> ..... 202	
Component Function Check ..... 175	System Description ..... 202	
	Air Mix Door Motor Component Function Check .. 202	

Air Mix Door Motor Diagnosis Procedure .....	203	Trouble Diagnoses for Unusual Pressure .....	249
<b>INTAKE DOOR MOTOR .....</b>	<b>207</b>	<b>INSUFFICIENT HEATING .....</b>	<b>252</b>
System Description .....	207	Component Function Check .....	252
Intake Door Motor Component Function Check ...	207	<b>NOISE .....</b>	<b>254</b>
Intake Door Motor Diagnosis Procedure .....	208	Component Function Check .....	254
<b>DEFROSTER DOOR MOTOR CIRCUIT .....</b>	<b>210</b>	<b>PRECAUTION .....</b>	<b>256</b>
System Description .....	210	<b>PRECAUTIONS .....</b>	<b>256</b>
Defroster Door Motor Component Function Check	..210	Supplemental Restraint System (SRS) "AIR BAG"	
Defroster Door Motor Diagnosis Procedure .....	211	and "SEAT BELT PRE-TENSIONER" .....	256
<b>BLOWER MOTOR CONTROL SYSTEM .....</b>	<b>215</b>	Working with HFC-134a (R-134a) .....	256
System Description .....	215	Precaution for Service Equipment .....	257
Front Blower Motor Component Function Check ..	215	<b>MANUAL A/C (TYPE 3)</b>	
Front Blower Motor Diagnosis Procedure .....	216	<b>BASIC INSPECTION .....</b>	<b>258</b>
Front Blower Motor Component Inspection .....	219	<b>MANUAL A/C IDENTIFICATION TABLE .....</b>	<b>258</b>
<b>MAGNET CLUTCH .....</b>	<b>221</b>	Application Table .....	258
System Description .....	221	<b>DIAGNOSIS AND REPAIR WORKFLOW .....</b>	<b>259</b>
Magnet Clutch Component Function Check .....	221	How to Perform Trouble Diagnosis For Quick And	
Magnet Clutch Diagnosis Procedure .....	221	Accurate Repair .....	259
<b>WATER VALVE CIRCUIT .....</b>	<b>226</b>	<b>INSPECTION AND ADJUSTMENT .....</b>	<b>260</b>
Description .....	226	Operational Check .....	260
Water Valve Diagnosis Procedure .....	226	<b>FUNCTION DIAGNOSIS .....</b>	<b>262</b>
<b>INTAKE SENSOR .....</b>	<b>228</b>	<b>MANUAL A/C IDENTIFICATION TABLE .....</b>	<b>262</b>
System Description .....	228	Application Table .....	262
Intake Sensor Diagnosis Procedure .....	228	<b>FUNCTION INFORMATION .....</b>	<b>263</b>
Intake Sensor Component Inspection .....	229	Component Part Location .....	263
<b>POWER SUPPLY AND GROUND CIRCUIT</b>		Symptom Table .....	265
<b>FOR CONTROLLER .....</b>	<b>230</b>	<b>REFRIGERATION SYSTEM .....</b>	<b>266</b>
Component Description .....	230	Refrigerant Cycle .....	266
Front Air Control Component Function Check .....	230	Refrigerant System Protection .....	266
Front Air Control Power and Ground Diagnosis		<b>MANUAL AIR CONDITIONER SYSTEM .....</b>	<b>267</b>
Procedure .....	231	Control System Diagram .....	267
<b>ECU DIAGNOSIS .....</b>	<b>232</b>	Control System Description .....	267
<b>MANUAL A/C IDENTIFICATION TABLE .....</b>	<b>232</b>	Discharge Air Flow .....	268
Application Table .....	232	Switches And Their Control Function .....	269
<b>AIR CONDITIONER CONTROL .....</b>	<b>233</b>	<b>CAN COMMUNICATION SYSTEM .....</b>	<b>271</b>
Front Air Control Terminals Reference Values .....	233	System Description .....	271
Wiring Diagram .....	235	<b>DIAGNOSIS SYSTEM (BCM) .....</b>	<b>272</b>
<b>SYMPTOM DIAGNOSIS .....</b>	<b>242</b>	CONSULT-III Function (BCM) .....	272
<b>MANUAL A/C IDENTIFICATION TABLE .....</b>	<b>242</b>	<b>COMPONENT DIAGNOSIS .....</b>	<b>273</b>
Application Table .....	242	<b>MANUAL A/C IDENTIFICATION TABLE .....</b>	<b>273</b>
<b>AIR CONDITIONER CONTROL .....</b>	<b>243</b>	Application Table .....	273
Symptom Matrix Chart .....	243	<b>MODE DOOR MOTOR .....</b>	<b>274</b>
<b>INSUFFICIENT COOLING .....</b>	<b>244</b>	System Description .....	274
Component Function Check .....	244	Mode Door Motor Component Function Check ...	274
Performance Test Diagnoses .....	245	Mode Door Motor Diagnosis Procedure .....	275
Performance Chart .....	247		
Test Reading .....	248		

<b>AIR MIX DOOR MOTOR</b> .....	<b>279</b>	Front Air Control Power and Ground Diagnosis Procedure .....	309	A
System Description .....	279			
Air Mix Door Motor Component Function Check ..	279			
Air Mix Door Motor Diagnosis Procedure .....	280			
<b>INTAKE DOOR MOTOR</b> .....	<b>284</b>	<b>ECU DIAGNOSIS</b> .....	<b>310</b>	B
System Description .....	284	<b>MANUAL A/C IDENTIFICATION TABLE</b> .....	<b>310</b>	
Intake Door Motor Component Function Check ...	284	Application Table .....	310	
Intake Door Motor Diagnosis Procedure .....	285	<b>AIR CONDITIONER CONTROL</b> .....	<b>311</b>	C
<b>DEFROSTER DOOR MOTOR CIRCUIT</b> .....	<b>287</b>	Front Air Control Terminals Reference Values .....	311	
System Description .....	287	Wiring Diagram .....	313	
Defroster Door Motor Component Function Check ..	287	<b>SYMPTOM DIAGNOSIS</b> .....	<b>321</b>	D
Defroster Door Motor Diagnosis Procedure .....	288	<b>MANUAL A/C IDENTIFICATION TABLE</b> .....	<b>321</b>	E
<b>BLOWER MOTOR CONTROL SYSTEM</b> .....	<b>292</b>	Application Table .....	321	
System Description .....	292	<b>AIR CONDITIONER CONTROL</b> .....	<b>322</b>	F
Front Blower Motor Component Function Check ..	292	Symptom Matrix Chart .....	322	
Front Blower Motor Diagnosis Procedure .....	293	<b>INSUFFICIENT COOLING</b> .....	<b>323</b>	G
Front Blower Motor Component Inspection .....	296	Component Function Check .....	323	
<b>MAGNET CLUTCH</b> .....	<b>299</b>	Performance Test Diagnoses .....	324	
System Description .....	299	Performance Chart .....	326	
Magnet Clutch Component Function Check .....	299	Test Reading .....	327	
Magnet Clutch Diagnosis Procedure .....	299	Trouble Diagnoses for Unusual Pressure .....	328	H
<b>WATER VALVE CIRCUIT</b> .....	<b>304</b>	<b>INSUFFICIENT HEATING</b> .....	<b>331</b>	
Description .....	304	Component Function Check .....	331	
Water Valve Diagnosis Procedure .....	304	<b>NOISE</b> .....	<b>333</b>	HAC
<b>INTAKE SENSOR</b> .....	<b>306</b>	Component Function Check .....	333	
System Description .....	306	<b>PRECAUTION</b> .....	<b>335</b>	J
Intake Sensor Diagnosis Procedure .....	306	<b>PRECAUTIONS</b> .....	<b>335</b>	K
Intake Sensor Component Inspection .....	307	Supplemental Restraint System (SRS) "AIR BAG" and "SEAT BELT PRE-TENSIONER" .....	335	
<b>POWER SUPPLY AND GROUND CIRCUIT FOR CONTROLLER</b> .....	<b>308</b>	Working with HFC-134a (R-134a) .....	335	L
Component Description .....	308	Precaution for Service Equipment .....	336	
Front Air Control Component Function Check .....	308			

## BASIC INSPECTION

### DIAGNOSIS AND REPAIR WORKFLOW

#### How to Perform Trouble Diagnosis For Quick And Accurate Repair

INFOID:000000001611774

#### WORK FLOW

##### 1. LISTEN TO CUSTOMER COMPLAINT

Listen to customer complaint. Get detailed information about the conditions and environment when the symptom occurs.

>> GO TO 2

##### 2. CHECK FOR SERVICE BULLETINS

Check for any service bulletins.

>> GO TO 3.

##### 3. VERIFY THE SYMPTOM WITH OPERATIONAL CHECK

Verify the symptom with operational check. Refer to [HAC-7, "Operational Check"](#).

Can a symptom be duplicated?

YES >> GO TO 4

NO >> GO TO 5

##### 4. GO TO APPROPRIATE TROUBLE DIAGNOSIS

Go to appropriate trouble diagnosis. Refer to [HAC-83, "Symptom Matrix Chart"](#).

Can a symptom be duplicated?

>> GO TO 5.

##### 5. PERFORM THE FRONT AIR CONTROL SELF-DIAGNOSIS

Perform front air control self-diagnosis. Refer to [HAC-21, "Front Air Control Self-Diagnosis"](#).

>> If any diagnostic trouble codes set. Refer to [HAC-21, "Front Air Control Self-Diagnosis Code Chart"](#).

>> Confirm the repair by performing operational check. Refer to [HAC-7, "Operational Check"](#).

# INSPECTION AND ADJUSTMENT

< BASIC INSPECTION >

[AUTOMATIC AIR CONDITIONER]

## INSPECTION AND ADJUSTMENT

### Operational Check

INFOID:000000001611775

The purpose of the operational check is to confirm that the system operates properly.

**Conditions : Engine running and at normal operating temperature**

#### CHECKING MEMORY FUNCTION

1. Set the temperature to 32° (90°F).
2. Press the OFF switch.
3. Turn ignition switch OFF.
4. Turn ignition switch ON.
5. Press the AUTO switch.
6. Confirm that the set temperature remains at previous temperature.

7. Press the OFF switch.

If NG, go to trouble diagnosis procedure for [HAC-96. "Memory Function Check"](#).

If OK, continue with next check.

#### CHECKING BLOWER

1. Rotate the blower control dial clockwise once, blower should operate on low speed.
2. Rotate the blower control dial again, and continue checking blower speed until all speeds are checked.
3. Leave blower on maximum speed.

If NG, go to trouble diagnosis procedure for [HAC-48. "Front Blower Motor Diagnosis Procedure"](#).

If OK, continue with next check.



#### CHECKING DISCHARGE AIR

1. Press each MODE switch and the DEF  switch.
2. Each MODE position indicator should illuminate.
3. Confirm that discharge air comes out according to the air distribution table. Refer to [HAC-15. "Discharge Air Flow"](#)  
Mode door position is checked in the next step.  
If NG, go to trouble diagnosis procedure for [HAC-24. "Mode Door Motor Diagnosis Procedure"](#).  
If OK, continue the check.

**NOTE:**

Confirm that the compressor clutch is engaged (sound or visual inspection) and intake door position is at fresh when the DEF or D/F is selected.





#### CHECKING RECIRCULATION ( , ONLY)

1. Press recirculation (  ) switch one time. Recirculation indicator should illuminate.
2. Press recirculation (  ) switch one more time. Recirculation indicator should go off.
3. Listen for intake door position change (blower sound should change slightly).

If NG, go to trouble diagnosis procedure for [HAC-39. "Intake Door Motor Diagnosis Procedure"](#).

If OK, continue the check.

**NOTE:**

Confirm that the compressor clutch is engaged (sound or visual inspection) and intake door position is at fresh when the DEF or D/F is selected. REC (  ) is not allowed in DEF (  ) D/F (  ) or FOOT (  ).

#### CHECKING TEMPERATURE DECREASE

1. Rotate temperature control dial (drive or passenger) counterclockwise until 18°C (60°F) is displayed.
2. Check for cold air at appropriate discharge air outlets.

If NG, listen for sound of air mix door motor operation. If OK, go to trouble diagnosis procedure for [HAC-84. "Component Function Check"](#). If air mix door motor appears to be malfunctioning, go to [HAC-29. "Air Mix Door Motor Component Function Check"](#).

A

B

C

D

E

F

G

H

HAC

J

K

L

M

N

O

P

## INSPECTION AND ADJUSTMENT

[AUTOMATIC AIR CONDITIONER]

< BASIC INSPECTION >

If OK, continue the check.

### CHECKING TEMPERATURE INCREASE

1. Rotate temperature control dial clockwise (drive or passenger) until 32°C (90°F) is displayed.
2. Check for hot air at appropriate discharge air outlets.

If NG, listen for sound of air mix door motor operation. If OK, go to trouble diagnosis procedure for [HAC-92, "Component Function Check"](#). If air mix door motor appears to be malfunctioning, go to [HAC-29, "Air Mix Door Motor Component Function Check"](#).

If OK, continue with next check.

### CHECK A/C SWITCH

1. Press A/C switch when AUTO switch is ON, or in manual mode.
2. A/C switch indicator will turn ON.
  - Confirm that the compressor clutch engages (sound or visual inspection).

#### NOTE:

If current mode setting is DEF or D/F, compressor clutch will already be engaged and cannot be turned off.

If NG, go to trouble diagnosis procedure for [HAC-54, "Magnet Clutch Diagnosis Procedure"](#).

If OK, continue with next check.

### CHECKING AUTO MODE

1. Press AUTO switch.
  2. AUTO indicator should illuminate.
    - If ambient temperature is warm, and selected temperature is cool, confirm that the compressor clutch engages (sound or visual inspection). (Discharge air and blower speed will depend on ambient, in-vehicle, and set temperatures.)
- If NG, go to trouble diagnosis procedure for [HAC-71, "Front Air Control Power and Ground Diagnosis Procedure"](#), then if necessary, trouble diagnosis procedure for [HAC-54, "Magnet Clutch Diagnosis Procedure"](#).
- If all operational checks are OK (symptom cannot be duplicated), go to malfunction Simulation Tests in [HAC-6, "How to Perform Trouble Diagnosis For Quick And Accurate Repair"](#) and perform tests as outlined to simulate driving conditions environment. If symptom appears. Refer to [HAC-83, "Symptom Matrix Chart"](#), and perform applicable trouble diagnosis procedures.



FUNCTION DIAGNOSIS

FUNCTION INFORMATION

Component Part Location

INFOID:000000001611777

ENGINE COMPARTMENT

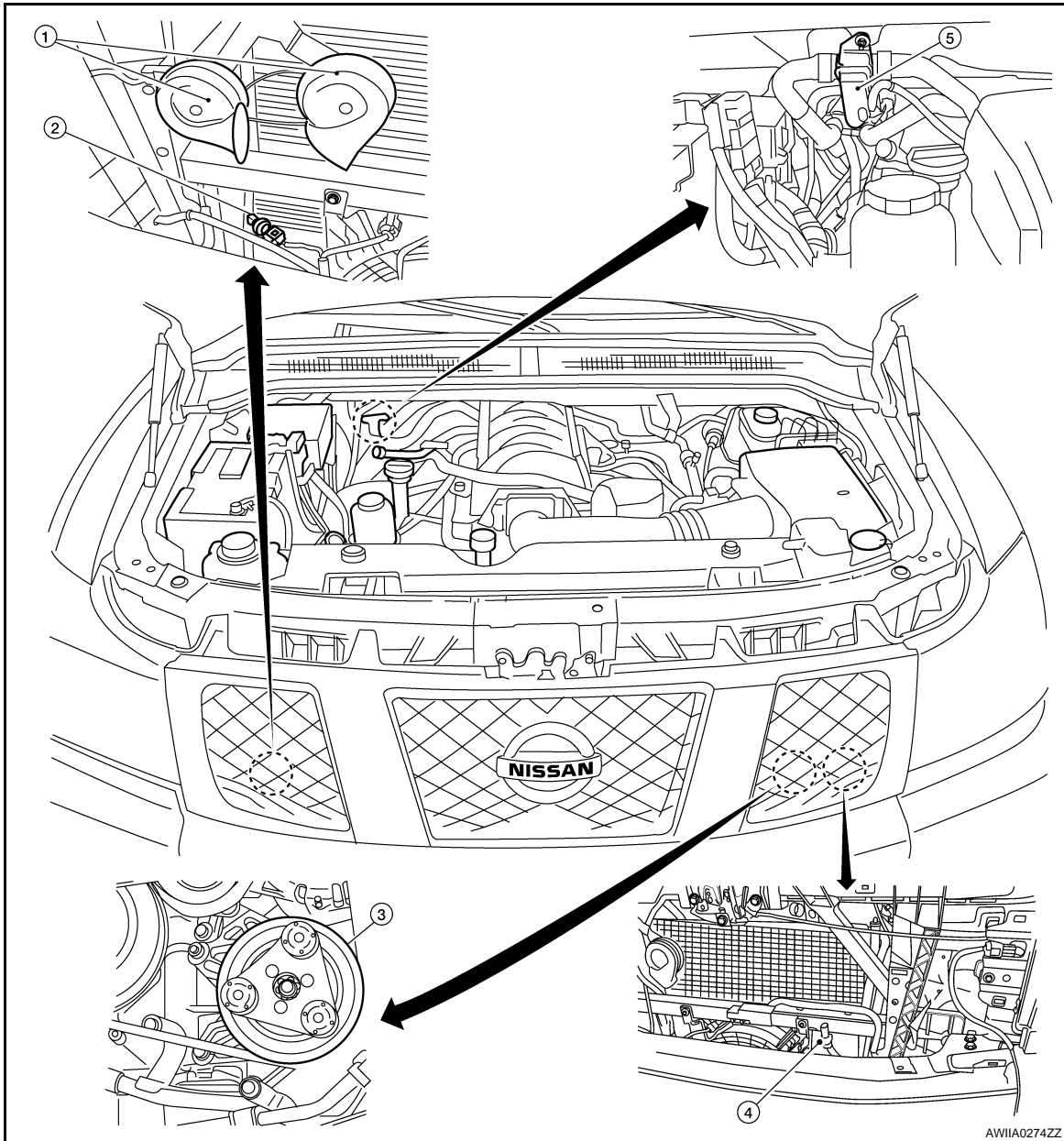

- 1. Horn (view with grille removed)
- 2. Refrigerant pressure sensor E111
- 3. A/C Compressor F3
- 4. Ambient sensor E1 (view with grille removed)
- 5. Water valve F68

A  
B  
C  
D  
E  
F  
G  
H  
HAC  
J  
K  
L  
M  
N  
O  
P

# FUNCTION INFORMATION

< FUNCTION DIAGNOSIS >

[AUTOMATIC AIR CONDITIONER]

## PASSENGER COMPARTMENT

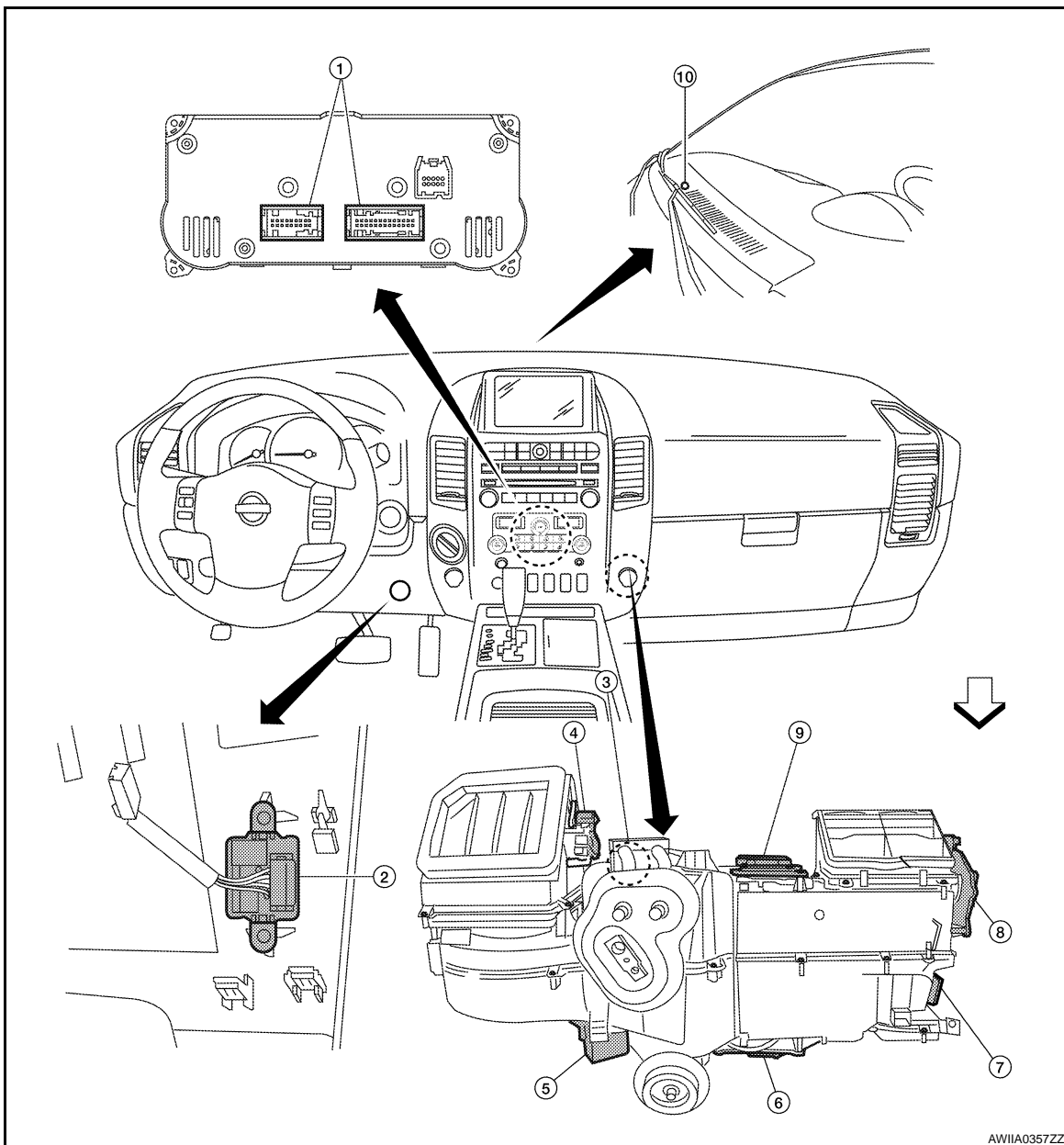

AWIA0357ZZ

- |                               |   |  |
|-------------------------------|---|--|
| 1. Front air control M49, M50 | 2. In-vehicle sensor M32                | 3. Intake sensor M146                  |
| 4. Intake door motor M58      | 5. Variable blower control (front) M122 | 6. Air mix door motor (Passenger) M143 |
| 7. Mode door motor M142       | 8. Defroster door motor M144            | 9. Air mix door motor (driver) M147    |
| 10. Optical sensor M302       | ← :Front                                |  |

# FUNCTION INFORMATION

< FUNCTION DIAGNOSIS >

[AUTOMATIC AIR CONDITIONER]

## Symptom Table

INFOID:000000001611778

Symptom	Reference Page	
A/C system does not come on.	Go to Trouble Diagnosis Procedure for A/C System.	<a href="#">HAC-71</a>
A/C system cannot be controlled.	Go to Self-diagnosis Function.	<a href="#">HAC-21</a>
Air outlet does not change.	Go to Trouble Diagnosis Procedure for Mode Door Motor.	<a href="#">HAC-24</a>
Mode door motor is malfunctioning.		
Discharge air temperature does not change.	Go to Trouble Diagnosis Procedure for Air Mix Door Motor.	<a href="#">HAC-29</a>
Air mix door motor is malfunctioning.		
Intake door does not change.	Go to Trouble Diagnosis Procedure for Intake Door Motor.	<a href="#">HAC-39</a>
Intake door motor is malfunctioning.		
Defroster door motor is malfunctioning.	Go to Trouble Diagnosis Procedure for Defroster Door Motor.	<a href="#">HAC-42</a>
Front blower motor operation is malfunctioning.	Go to Trouble Diagnosis Procedure for Front Blower Motor.	<a href="#">HAC-48</a>
Magnet clutch does not engage.	Go to Trouble Diagnosis Procedure for Magnet Clutch.	<a href="#">HAC-54</a>
Insufficient cooling	Go to Trouble Diagnosis Procedure for Insufficient Cooling.	<a href="#">HAC-84</a>
Insufficient heating	Go to Trouble Diagnosis Procedure for Insufficient Heating.	<a href="#">HAC-92</a>
Noise	Go to Trouble Diagnosis Procedure for Noise.	<a href="#">HAC-94</a>
Self-diagnosis cannot be performed.	Go to Trouble Diagnosis Procedure for Self-diagnosis.	<a href="#">HAC-21</a>
Memory function does not operate.	Go to Trouble Diagnosis Procedure for Memory Function.	<a href="#">HAC-96</a>

A  
B  
C  
D  
E  
F  
G  
H  
J  
K  
L  
M  
N  
O  
P

HAC

## REFRIGERATION SYSTEM

### Refrigerant Cycle

INFOID:000000001611779

Refer to [HAC-12. "Refrigerant Cycle"](#).

### Refrigerant System Protection

INFOID:000000001611780

Refer to [HAC-12. "Refrigerant System Protection"](#).

# AUTOMATIC AIR CONDITIONER SYSTEM

< FUNCTION DIAGNOSIS >

[AUTOMATIC AIR CONDITIONER]

## AUTOMATIC AIR CONDITIONER SYSTEM

### Control System Diagram

INFOID:000000001611781

### CONTROL SYSTEM

The control system consists of input sensors, switches, the front air control (microcomputer) and outputs. The relationship of these components is shown in the figure below:

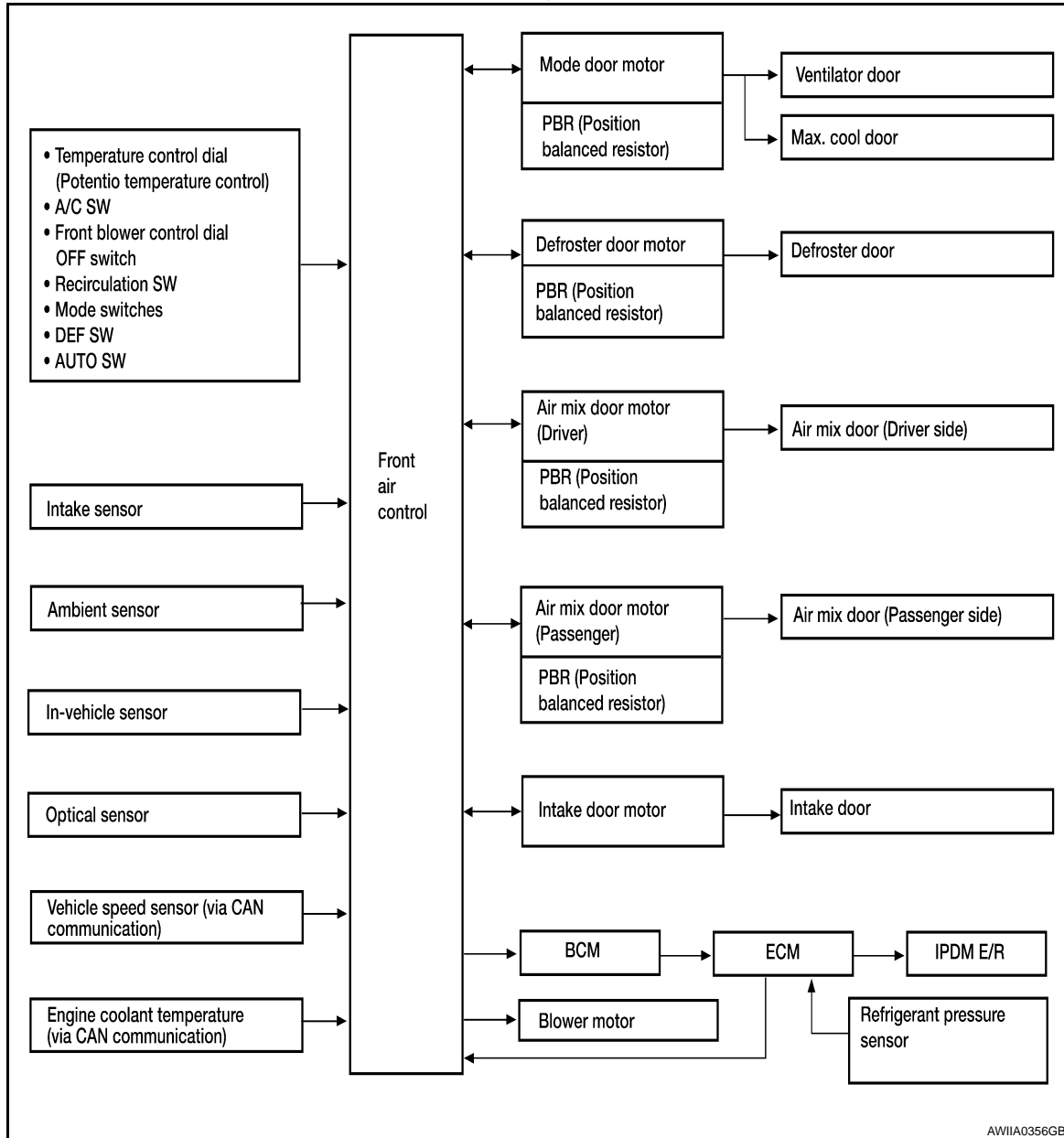

### Control System Description

INFOID:000000001611782

### CONTROL OPERATION

# AUTOMATIC AIR CONDITIONER SYSTEM

< FUNCTION DIAGNOSIS >

[AUTOMATIC AIR CONDITIONER]

Front air control

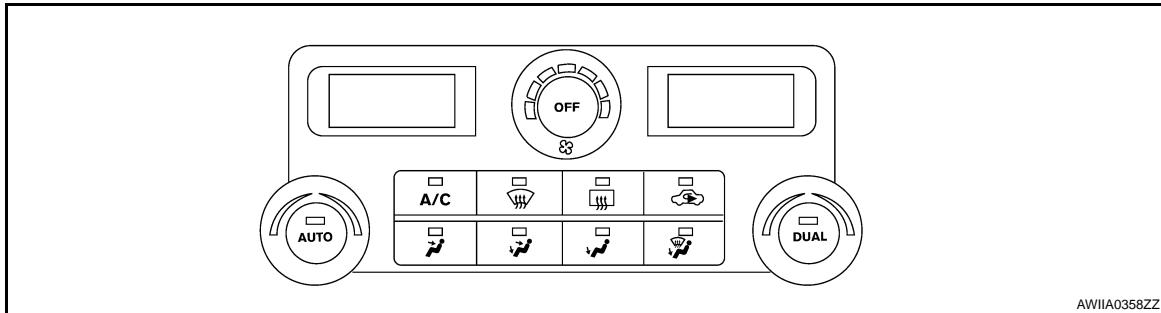

## AUTO SWITCH

- The compressor, intake door, air mix doors, outlet doors and blower speed are automatically controlled so that the in-vehicle temperature will reach, and be maintained at the set temperature selected by the operator.
- When pressing AUTO switch, air inlet, air outlet, blower speed, and discharge air temperature are automatically controlled.

## TEMPERATURE CONTROL DIAL (DRIVER)

Increases or decreases the set temperature.

## TEMPERATURE CONTROL DIAL (PASSENGER)

Increases or decreases the set temperature.

## RECIRCULATION ( ) SWITCH

- When REC switch is ON, REC switch indicator turns ON, and air inlet is set to REC.
- When REC switch is turned OFF, or when compressor is turned from ON to OFF, REC switch is automatically turned OFF. REC mode can be re-entered by pressing REC switch again.
- REC switch is not operated when DEF switch is turned ON, at the D/F position, or in floor position.

## DEFROSTER ( ) SWITCH

Positions the air outlet doors to the defrost position. Also positions the intake doors to the outside air position, and turns A/C compressor ON.

## REAR WINDOW DEFOGGER SWITCH (CREW CAB)

When switch is ON, rear window and door mirrors are defogged.

## OFF SWITCH

The compressor and blower are OFF, the intake doors are set to the outside air position, and the air outlet doors are set to the foot (75% foot and 25% defrost) position.

## BLOWER CONTROL DIAL

The blower speed is manually controlled with this dial.

## A/C SWITCH

The compressor is ON or OFF.

(Pressing the A/C switch when the AUTO switch is ON will turn off the A/C switch and compressor.)

## MODE SWITCHES

Controls the air discharge outlets.

## DUAL SWITCH

- When the DUAL switch indicator is illuminated, the driver and passenger temperature can each be set independently.
- When the DUAL switch indicator is not illuminated, the driver temperature setting is applied to both sides.

# AUTOMATIC AIR CONDITIONER SYSTEM

< FUNCTION DIAGNOSIS >

[AUTOMATIC AIR CONDITIONER]

## MAGNET CLUTCH CONTROL

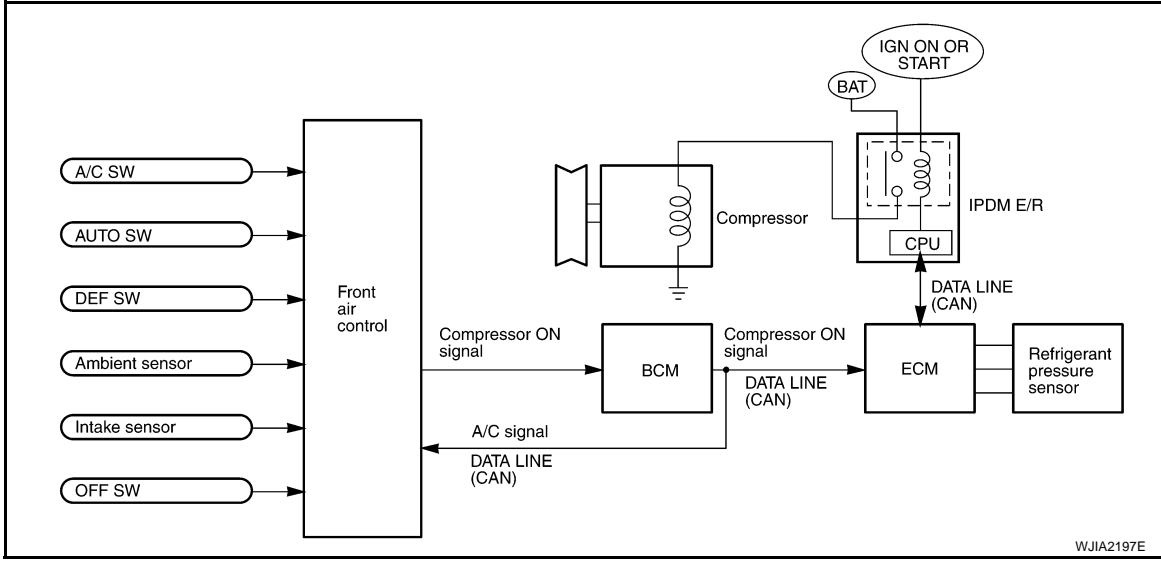

When A/C switch or DEF switch is pressed, front air control inputs compressor ON signal to BCM. BCM sends compressor ON signal to ECM and front air control, via CAN communication line. ECM judges whether compressor can be turned ON, based on each sensor status (refrigerant pressure sensor signal, throttle angle sensor, etc.). If it judges compressor can be turned ON, it sends compressor ON signal to IPDM E/R, via CAN communication line. Upon receipt of compressor ON signal from ECM, IPDM E/R turns air conditioner relay ON to operate compressor.

## Discharge Air Flow

INFOID:000000001611783

HAC

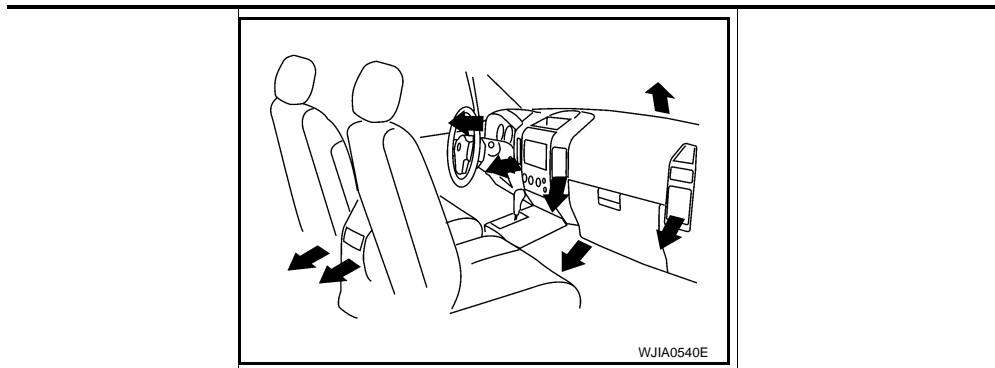

Mode door position	Air outlet/distribution		
	Vent	Foot	Defroster
	95%	5%	—
	60%	40%	—
	—	70%	30%
	—	60%	40%
	—	10%	90%

# AUTOMATIC AIR CONDITIONER SYSTEM

< FUNCTION DIAGNOSIS >

[AUTOMATIC AIR CONDITIONER]

## Switches And Their Control Function

INFOID:000000001611785

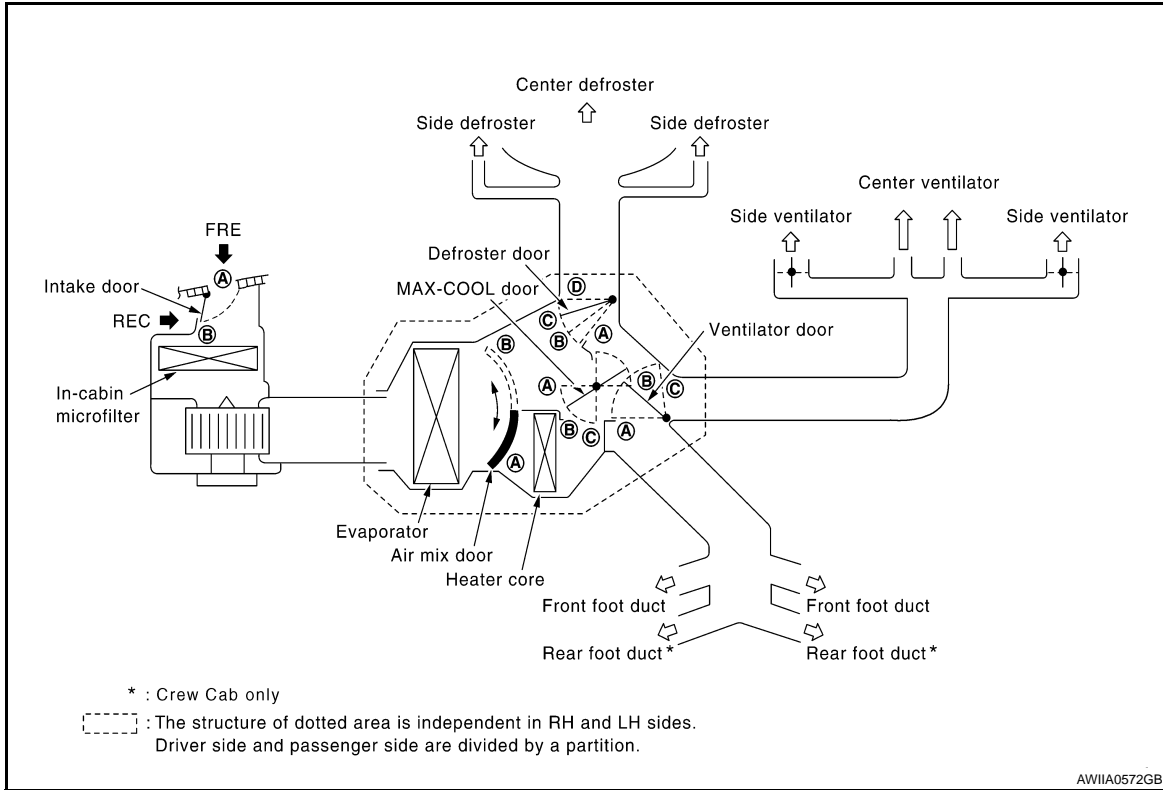

Position or switch	MODE SW				DEF SW		REC SW		Temperature control dial			OFF SW
	VENT	B/L	FOOT	D/F	ON	OFF	ON	OFF				
Door					FRONT 				COLD	~	HOT	
Ventilator door	(A)	(B)	(C)	(C)	(C)	—	—	—	—	—	—	(C)
MAX-COOL door	(A)	(B)	(B)	(B)	(C)	—	—	—	—	—	—	(B)
Defroster door	(D)	(D)	(D <sub>or</sub> C)	(B)	(A)	—	—	—	—	—	—	(C)
Intake door	—				(B)	—	(A)	(B)	—	—	—	(B)
Air mix door	—				—	—	—	—	(A)	AUTO	(B)	—

AWIIA0359GB



# CAN COMMUNICATION SYSTEM

< FUNCTION DIAGNOSIS >

[AUTOMATIC AIR CONDITIONER]

## CAN COMMUNICATION SYSTEM

### System Description

INFOID:000000001611787

Refer to [LAN-4. "System Description"](#).

A

B

C

D

E

F

G

H

**HAC**

J

K

L

M

N

O

P

# DIAGNOSIS SYSTEM (HVAC)

< FUNCTION DIAGNOSIS >

[AUTOMATIC AIR CONDITIONER]

## DIAGNOSIS SYSTEM (HVAC)

### CONSULT-III Function (HVAC)

INFOID:000000001611788

CONSULT-III can display each diagnostic item using the diagnostic test modes shown following.

Diagnostic mode	Description
SELF-DIAG RESULTS	Displays Front air control self-diagnosis results.
DATA MONITOR	Displays Front air control input/output data in real time.
CAN DIAG SUPPORT MNTR	The result of transmit/receive diagnosis of CAN communication can be read.
ECU PART NUMBER	Front air control part number can be read.

### SELF-DIAGNOSIS

#### Display Item List

DTC	Description	Reference page
B2573	Battery voltage out of range	<a href="#">CHG-4, "Work Flow"</a>
B2578	In-vehicle sensor circuit out of range (low)	<a href="#">HAC-63, "In-Vehicle Sensor Diagnosis Procedure"</a>
B2579	In-vehicle sensor circuit out of range (high)	
B257B	Ambient sensor circuit short	<a href="#">HAC-61, "Ambient Sensor Component Inspection"</a>
B257C	Ambient sensor circuit open	
B257F	Optical sensor (Driver) circuit open or short	<a href="#">HAC-66, "Optical Sensor Diagnosis Procedure"</a>
B2580	Optical sensor (Passenger) circuit open or short	
B2581	Intake sensor circuit short	<a href="#">HAC-69, "Intake Sensor Component Inspection"</a>
B2582	Intake sensor circuit open	
B2587	Stuck button	<a href="#">VTL-8, "Removal and Installation"</a>
U1000	CAN bus fault	<a href="#">LAN-14, "Trouble Diagnosis Flow Chart"</a>

### DATA MONITOR

#### Display Item List

Monitor item	Value	Contents
BATT VIA CAN	"V"	Displays battery voltage signal.
IGN VIA CAN	"ON/OFF"	Displays ignition switch signal.
DVR SUNLD SEN	"w/m2"	Displays optical sensor (driver) signal.
PAS SUNLD SEN	"w/m2"	Displays optical sensor (passenger) signal.
AMB TEMP SEN	"°C"	Displays ambient sensor signal.
EVAP TEMP SEN	"°C"	Displays intake sensor signal.
INCAR TMP SEN	"°C"	Displays in-vehicle sensor signal.
MODE FDBCK	"V"	Displays mode door motor feedback signal.
DVR MIX FDBCK	"V"	Displays air mix door motor (driver) feedback signal.
PAS MIX FDBCK	"V"	Displays air mix door motor (passenger) feedback signal.
DEF FDBCK	"V"	Displays defroster door motor feedback signal.
RECIRC	"ON/OFF"	Displays recirculation switch signal.
DEFROST	"ON/OFF"	Displays defroster switch signal.
AUTO	"ON/OFF"	Displays AUTO switch signal.
A/C	"ON/OFF"	Displays A/C switch signal.

# DIAGNOSIS SYSTEM (HVAC)

[AUTOMATIC AIR CONDITIONER]

< FUNCTION DIAGNOSIS >

Monitor item	Value	Contents
L TEMP UP	"ON/OFF"	Displays driver side temperature control dial (temp increase) signal.
L TEMP DOWN	"ON/OFF"	Displays driver side temperature control dial (temp decrease) signal.
R TEMP UP	"ON/OFF"	Displays passenger temperature control dial (temp increase) signal.
R TEMP DOWN	"ON/OFF"	Displays passenger temperature control dial (temp decrease) signal.
RR DEFOG	"ON/OFF"	Displays rear defroster request signal.
FAN UP	"ON/OFF"	Displays blower motor (blower speed increase) signal.
FAN DOWN	"ON/OFF"	Displays blower motor (blower speed decrease) signal.

A

B

C

D

E

F

G

H

HAC

J

K

L

M

N

O

P

# DIAGNOSIS SYSTEM (BCM)

< FUNCTION DIAGNOSIS >

[AUTOMATIC AIR CONDITIONER]

## DIAGNOSIS SYSTEM (BCM)

### CONSULT-III Function (BCM)

INFOID:000000001611789

CONSULT-II can display each diagnostic item using the diagnostic test modes shown following.

BCM diagnostic test item	Diagnostic mode	Description
Inspection by part	WORK SUPPORT	Supports inspections and adjustments. Commands are transmitted to the BCM for setting the status suitable for required operation, input/output signals are received from the BCM and received data is displayed.
	DATA MONITOR	Displays BCM input/output data in real time.
	ACTIVE TEST	Operation of electrical loads can be checked by sending drive signal to them.
	SELF-DIAG RESULTS	Displays BCM self-diagnosis results.
	CAN DIAG SUPPORT MNTR	The result of transmit/receive diagnosis of CAN communication can be read.
	ECU PART NUMBER	BCM part number can be read.
	CONFIGURATION	Performs BCM configuration read/write functions.

### DATA MONITOR

#### Display Item List

Monitor item name "operation or unit"	Contents
IGN ON SW "ON/OFF"	Displays "IGN Position (ON)/OFF, ACC Position (OFF)" status as judged from ignition switch signal.
COMP ON SIG "ON/OFF"	Displays "COMP (ON)/COMP (OFF)" status as judged from air conditioner switch signal.
FAN ON SIG "ON/OFF"	Displays "FAN (ON)/FAN (OFF)" status as judged from blower motor switch signal.

# SELF-DIAGNOSIS FUNCTION

< FUNCTION DIAGNOSIS >

[AUTOMATIC AIR CONDITIONER]

## SELF-DIAGNOSIS FUNCTION

### Front Air Control Self-Diagnosis

INFOID:000000001611790



#### A/C SYSTEM SELF-DIAGNOSIS FUNCTION

The self-diagnosis function is built into the front air control to quickly locate the cause of malfunctions.

#### DESCRIPTION

The self-diagnostic system diagnoses sensors, CAN system, and battery voltage on front air control. Refer to applicable sections (items) for details. Fault codes (if any are present) will be displayed in the ambient temperature display area. Refer to [HAC-21, "Front Air Control Self-Diagnosis Code Chart"](#).

#### SELF-DIAGNOSTIC MODE

1. Press the OFF switch.
2. Press the FLOOR/DEF (  ) and DEF (  ) mode switches together and release on the front air control.
3. Press the REC (  ) to enter self diagnostic mode.
4. Turn ignition switch OFF to exit out of self-diagnostic mode.

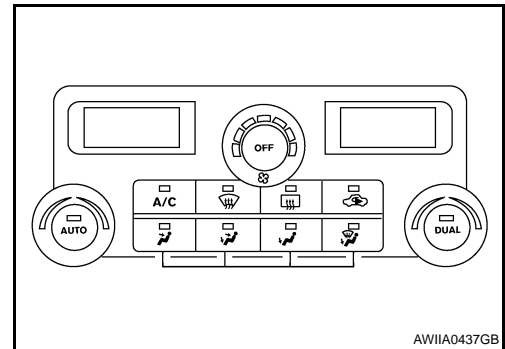

### Front Air Control Self-Diagnosis Code Chart

INFOID:000000001611792

#### SELF-DIAGNOSTIC CODE CHART

Code No.	Reference page	
03	Battery voltage out of range	<a href="#">CHG-4, "Work Flow"</a>
30	In-vehicle sensor circuit out of range (low)	<a href="#">HAC-63, "In-Vehicle Sensor Diagnosis Procedure"</a>
31	In-vehicle sensor circuit out of range (high)	
40	Ambient sensor circuit short	<a href="#">HAC-60, "Ambient Sensor Diagnosis Procedure"</a>
41	Ambient sensor circuit open	
50	Optical sensor (Driver) circuit open or short	<a href="#">HAC-66, "Optical Sensor Diagnosis Procedure"</a>
52	Optical sensor (Passenger) circuit open or short	
56	Intake sensor circuit short	<a href="#">HAC-68, "Intake Sensor Diagnosis Procedure"</a>
57	Intake sensor circuit open	
80	CAN bus fault	<a href="#">LAN-14, "Trouble Diagnosis Flow Chart"</a>
90	Stuck button	<a href="#">VTL-8, "Removal and Installation"</a>

# COMPONENT DIAGNOSIS

## MODE DOOR MOTOR

### System Description

INFOID:000000001611793

### SYSTEM DESCRIPTION

#### Component Parts

Mode door control system components are:

- Front air control
- Mode door motor (front)
- PBR (built into mode door motor)
- In-vehicle sensor
- Ambient sensor
- Optical sensor
- Intake sensor

#### System Operation

The mode door position (vent, B/L, foot, D/F, and defrost) is set by the front air control by means of the mode door motor. When a mode door position is selected on the front air control, voltage is applied to one circuit of the mode door motor while ground is applied to the other circuit, causing the mode door motor to rotate. The direction of rotation is determined by which circuit has voltage applied to it, and which one has ground applied to it. The front air control monitors the mode door position by measuring the voltage signal on the PBR circuit. In AUTO mode the mode door position is set by the front air control which determines the proper position based on inputs from the in-vehicle sensor, ambient sensor, optical sensor, intake sensor, and the temperature selected by the driver or passenger.

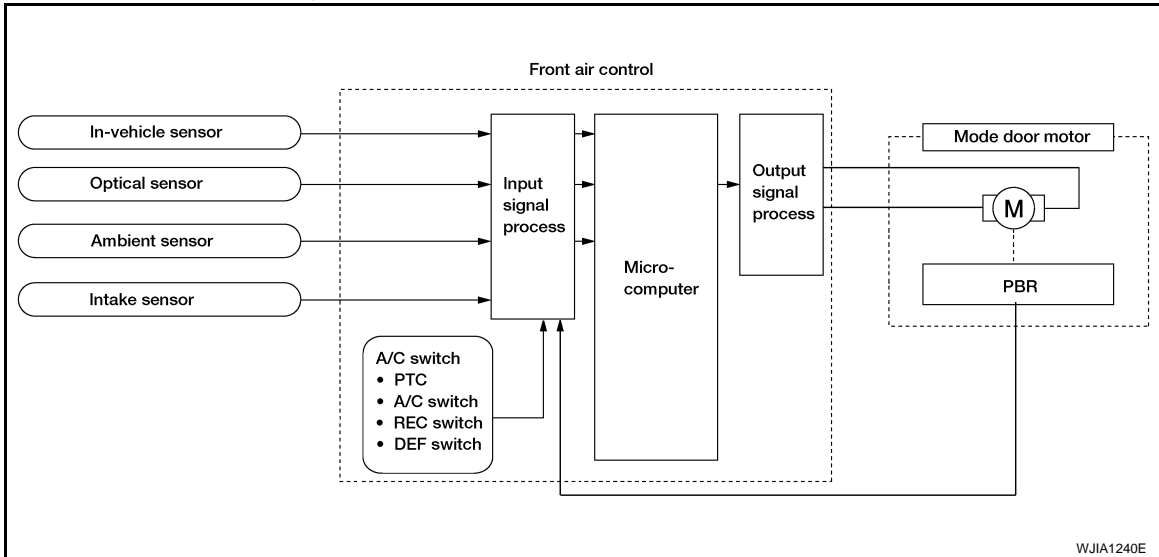

#### Mode Door Control Specification

### COMPONENT DESCRIPTION

#### Mode Door Motor

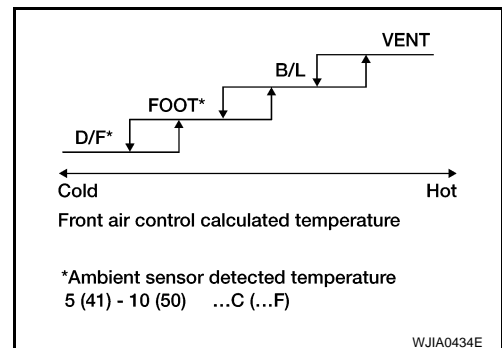

# MODE DOOR MOTOR

[AUTOMATIC AIR CONDITIONER]

## < COMPONENT DIAGNOSIS >

The mode door motor is attached to the heater & cooling unit assembly. It rotates so that air is discharged from the outlet as indicated by the front air control. Motor rotation is conveyed to a link which activates the mode door.

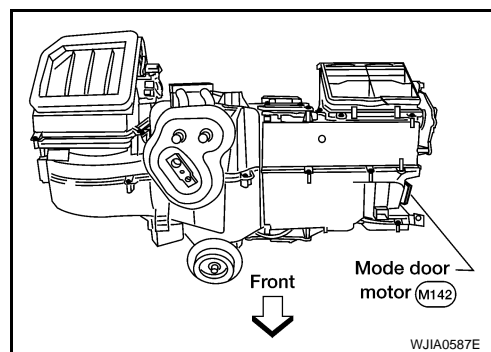

## Mode Door Motor Component Function Check



INFOID:000000001611794

### INSPECTION FLOW

#### 1. CONFIRM SYMPTOM BY PERFORMING OPERATIONAL CHECK - DISCHARGE AIR

1. Press each mode switch and press the  (DEF) switch. Each position indicator should illuminate.
2. Confirm that discharge air comes out according to the air distribution table. Refer to [HAC-15, "Discharge Air Flow"](#).

#### NOTE:

Confirm that the compressor clutch is engaged (visual inspection) and intake door position is at FRESH  when DEF () or D/F () is selected.

Can a symptom be duplicated?

- YES >> GO TO 3.
- NO >> GO TO 2.

#### 2. PERFORM COMPLETE OPERATIONAL CHECK

Perform a complete operational check and check for any symptoms. Refer to [HAC-7, "Operational Check"](#).

Can a symptom be duplicated?

- YES >> Refer to [HAC-6, "How to Perform Trouble Diagnosis For Quick And Accurate Repair"](#).
- NO >> System OK.

#### 3. CHECK FOR SERVICE BULLETINS

Check for any service bulletins.

>> GO TO 4.

#### 4. CHECK MODE DOOR OPERATION

Check and verify mode door mechanism for smooth operation in each mode.

Is the inspection result normal?

- YES >> GO TO 5.
- NO >> Repair as necessary.

#### 5. PERFORM FRONT AIR CONTROL SELF-DIAGNOSIS

Perform self-diagnosis to check for any codes. Refer to [HAC-21, "Front Air Control Self-Diagnosis"](#).

Are any self-diagnosis codes present?

- YES >> Refer to [HAC-21, "Front Air Control Self-Diagnosis Code Chart"](#).
- NO >> GO TO 6.

#### 6. CHECK THE MODE DOOR MOTOR PBR CIRCUIT

Perform diagnostic procedure for the mode door motor. Refer to [HAC-23, "Mode Door Motor Component Function Check"](#).

Is the inspection result normal?

- YES >> GO TO 7.
- NO >> Repair PBR circuit or replace motor. Refer to [HAC-24, "Mode Door Motor Diagnosis Procedure"](#).

#### 7. RECHECK FOR CODES

# MODE DOOR MOTOR

[AUTOMATIC AIR CONDITIONER]

## < COMPONENT DIAGNOSIS >

Perform front air control self-diagnosis. Refer to [HAC-21. "Front Air Control Self-Diagnosis"](#).

Are any self-diagnostic codes present?

- YES >> Refer to [HAC-21. "Front Air Control Self-Diagnosis Code Chart"](#).
- NO >> GO TO 8.

## 8.RECHECK FOR SYMPTOMS

Perform a complete operational check and check for any symptoms. Refer to [HAC-7. "Operational Check"](#).

Does another symptom exist?

- YES >> Repair as necessary.
- NO >> Replace front air control Refer to [VTL-8. "Removal and Installation"](#).

## Mode Door Motor Diagnosis Procedure

INFOID:000000001611795

SYMPTOM:

- Air outlet does not change.
- Mode door motor does not operate normally.

## 1.CHECK FRONT AIR CONTROL FOR POWER AND GROUND

1. Turn ignition switch ON.
2. Press the B/L (☺) mode switch.
3. Check voltage between front air control harness connector M49 terminal 19 and terminal 20 while pressing the mode switch to the floor (☹) mode.

Connector	Terminals		Condition	Voltage (Approx.)
	(+)	(-)		
Front air control: M49	20	19	Press mode switch	Battery voltage

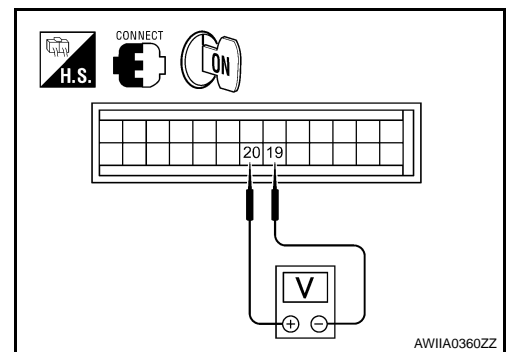

Is the inspection result normal?

- YES >> GO TO 4.
- NO >> GO TO 3.

## 2.CHECK MODE DOOR MOTOR CIRCUITS FOR SHORT TO GROUND

1. Turn ignition switch OFF.
2. Disconnect the front air control harness connector.
3. Check continuity between front air control harness connector M49 terminal 19, 20 and ground.

- 19 - Ground : Continuity should not exist.**
- 20 - Ground : Continuity should not exist.**

Is the inspection result normal?

- YES >> Replace front air control. Refer to [VTL-8. "Removal and Installation"](#).
- NO >> Repair or replace harness as necessary.

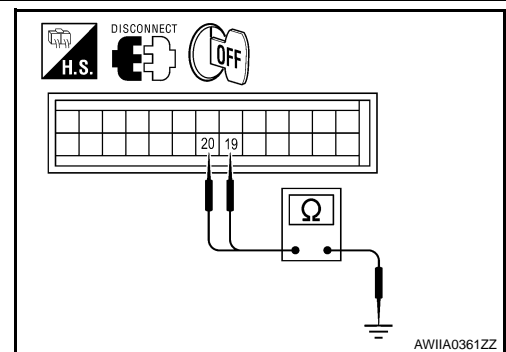

## 3.CHECK FRONT AIR CONTROL FOR GROUND AND POWER



# MODE DOOR MOTOR

[AUTOMATIC AIR CONDITIONER]

## < COMPONENT DIAGNOSIS >

1. Press the mode switch to the D/F ( ) mode.
2. Check voltage between front air control harness connector M49 terminal 19 and terminal 20 while pressing the mode switch to the vent ( ) mode.

Connector	Terminals		Condition	Voltage (Approx.)
	(+)	(-)		
Front air control: M49	19	20	Press mode switch	Battery voltage

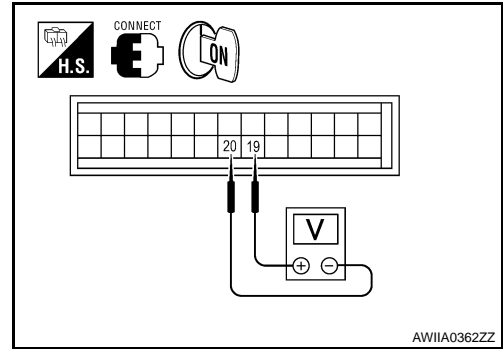

Is the inspection result normal?

YES >> GO TO 5.

NO >> Replace front air control. Refer to [VTL-8, "Removal and Installation"](#).

## 4. CHECK MODE DOOR MOTOR AND CIRCUITS FOR OPEN

1. Turn ignition switch OFF.
2. Disconnect the front air control harness connector.
3. Check continuity between front air control harness connector M49 terminal 19 and terminal 20.

**Continuity should exist.**

Is the inspection result normal?

YES >> GO TO 7.

NO >> GO TO 6.

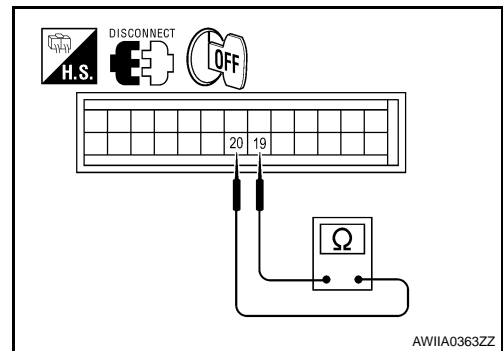

## 5. CHECK MODE DOOR MOTOR CIRCUITS FOR OPEN

1. Disconnect the mode door motor harness connector.
2. Check continuity between front air control harness connector M49 (A) terminal 19, 20 and the mode door motor harness connector M142 (B) terminal 5, 6.

**5 - 19 : Continuity should exist.**

**6 - 20 : Continuity should exist.**

Is the inspection result normal?

YES >> Replace mode door motor. Refer to [VTL-19, "Removal and Installation"](#).

NO >> Repair or replace harness as necessary.

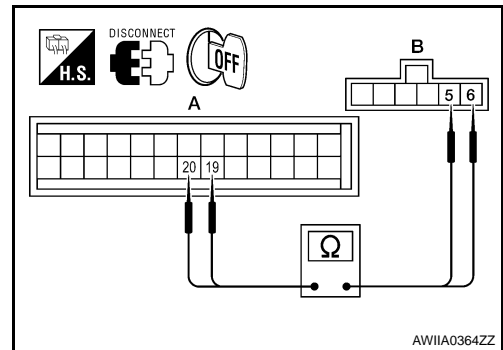

## 6. CHECK FRONT AIR CONTROL FOR PBR POWER AND GROUND

1. Reconnect front air control harness connector.
2. Turn ignition switch ON.
3. Check voltage between front air control harness connector M50 (A) terminal 28 and M49 (B) terminal 3.

Connector	Terminals		Voltage (Approx.)
	(+)	(-)	
Front air control: M49, M50	28	3	5V

Is the inspection result normal?

YES >> GO TO 9.

NO >> GO TO 8.

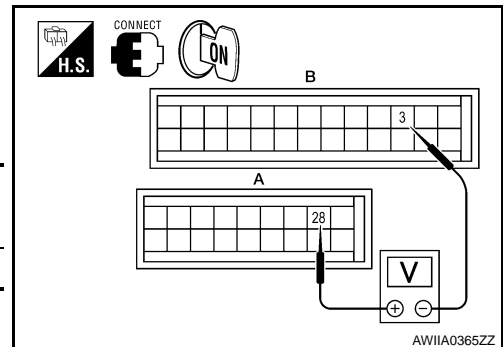

## 7. CHECK PBR REFERENCE VOLTAGE CIRCUIT FOR SHORT TO GROUND

# MODE DOOR MOTOR

[AUTOMATIC AIR CONDITIONER]

## < COMPONENT DIAGNOSIS >

1. Turn ignition switch OFF.
2. Disconnect the front air control harness connector.
3. Check continuity between front air control harness connector M50 terminal 28 and ground.

**Continuity should not exist.**

Is the inspection result normal?

- YES >> Replace front air control Refer to [VTL-8, "Removal and Installation"](#).
- NO >> Repair or replace harness as necessary.

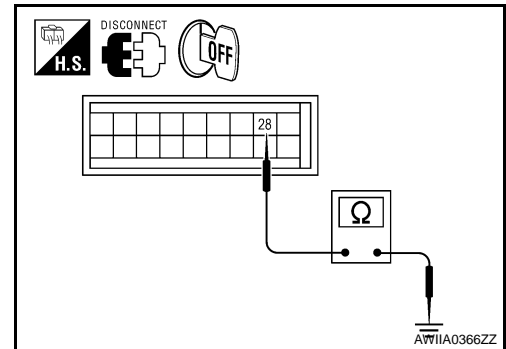

## 8.CHECK PBR REFERENCE VOLTAGE AND GROUND CIRCUITS

1. Turn ignition switch OFF.
2. Disconnect the front air control harness connector.
3. Check continuity between front air control harness connector M50 (A) terminal 28 and M49 (B) terminal 3.

**Continuity should exist.**

Is the inspection result normal?

- YES >> GO TO 11.
- NO >> GO TO 10

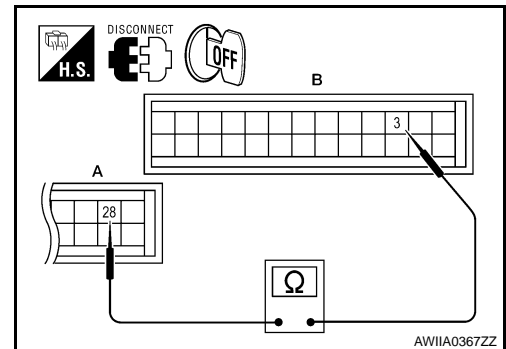

## 9.CHECK PBR REFERENCE VOLTAGE CIRCUIT FOR OPEN

1. Disconnect the mode door motor harness connector.
2. Check continuity between mode door motor harness connector M142 (B) terminal 3, 1 and front air control harness connector M49 (C) terminal 3, M50 (A) terminal 28.

**28 - 1 : Continuity should exist.**

**3 - 3 : Continuity should exist.**

Is the inspection result normal?

- YES >> Replace mode door motor. Refer to [VTL-19, "Removal and Installation"](#).
- NO >> Repair or replace harness as necessary.

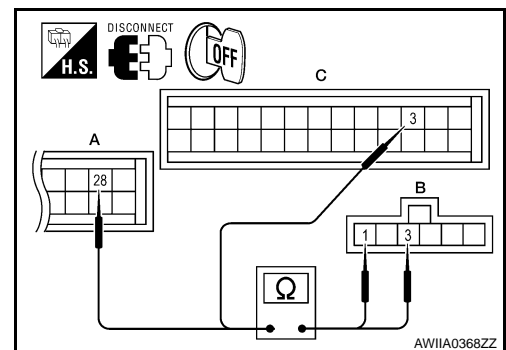

## 10.CHECK PBR FEEDBACK VOLTAGE

1. Reconnect the front air control harness connector.
2. Turn ignition switch ON.
3. Check voltage between front air control harness connector M49 terminal 7 and ground while cycling mode switch through all modes.

**Voltage : Approx. 1V - 4.5V**

Is the inspection result normal?

- YES >> GO TO 13.
- NO >> GO TO 12.

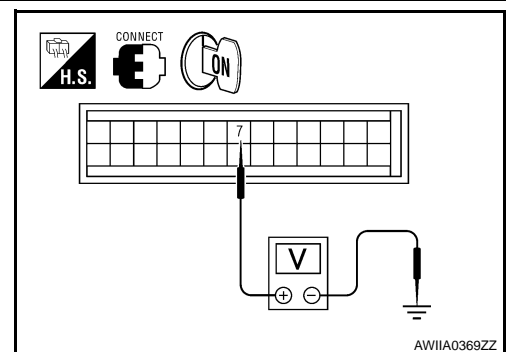

## 11.CHECK PBR FEEDBACK SIGNAL CIRCUIT FOR SHORT TO GROUND

# MODE DOOR MOTOR

[AUTOMATIC AIR CONDITIONER]

## < COMPONENT DIAGNOSIS >

1. Turn ignition switch OFF.
2. Disconnect front air control harness connector.
3. Check continuity between front air control harness connector M49 terminal 7 and ground.

**Continuity should not exist.**

Is the inspection result normal?

YES >> Replace front air control Refer to [VTL-8, "Removal and Installation"](#).

NO >> Repair or replace harness as necessary.

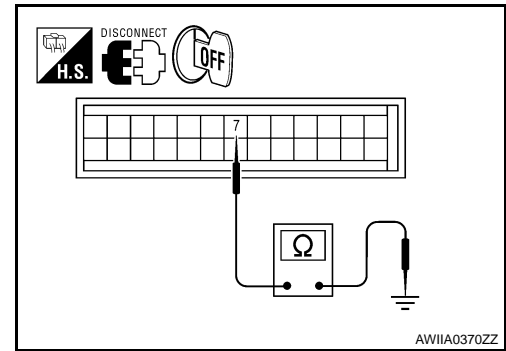

## 12. CHECK PBR FEEDBACK CIRCUIT FOR OPEN

1. Turn ignition switch OFF.
2. Disconnect the mode door motor harness connector and front air control harness connector.
3. Check continuity between mode door motor harness connector M142 terminal 2 and front air control harness connector M49 terminal 7.

**Continuity should exist.**

Is the inspection result normal?

YES >> Replace mode door motor. Refer to [VTL-19, "Removal and Installation"](#).

NO >> Repair or replace harness as necessary.

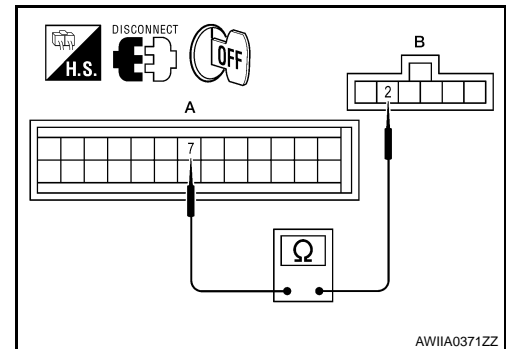

A  
B  
C  
D  
E  
F  
G  
H  
J  
K  
L  
M  
N  
O  
P

HAC

## AIR MIX DOOR MOTOR

### System Description

INFOID:000000001611796

### SYSTEM DESCRIPTION

#### SYMPTOM:

- Discharge air temperature does not change.
- Air mix door motor does not operate.

### SYSTEM DESCRIPTION

#### Component Parts

Air mix door control system components are:

- Front air control
- Air mix door motors (driver, passenger)
- PBR (built-into air mix door motors)
- In-vehicle sensor
- Ambient sensor
- Optical sensor
- Intake sensor

#### System Operation

The front air control receives data from the temperature selected by the driver side, passenger side, and rear. The front air control then applies a voltage to one circuit of the appropriate air mix door motor, while ground is applied to the other circuit, causing the appropriate air mix door motor to rotate. The direction of rotation is determined by which circuit has voltage applied to it, and which one has ground applied to it. The front air control monitors the air mix door positions by measuring the voltage signal on the PBR circuits of each door.

In AUTO mode the air mix, intake, mode door, and defrost door positions are set by the front air control which determines the proper position based on inputs from the in-vehicle sensor, ambient sensor, optical sensor, intake sensor, and the temperature selected by the driver and front and rear passengers.

Subsequently, HOT/COLD or DEFROST/VENT or FRESH/RECIRCULATION operation is selected. The new door position data is returned to the front air control

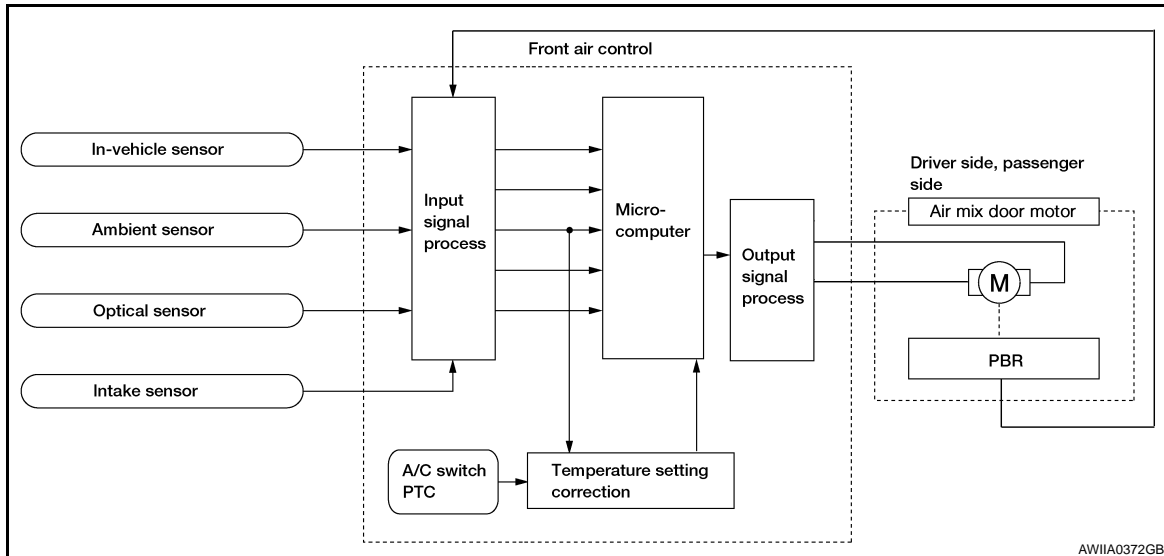

# AIR MIX DOOR MOTOR

< COMPONENT DIAGNOSIS >

[AUTOMATIC AIR CONDITIONER]

Air Mix Door Control Specification

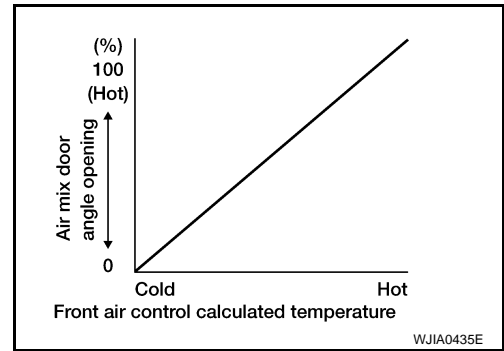

## COMPONENT DESCRIPTION

Air Mix Door Motors

The driver (1) and passenger (2) air mix door motors are attached to the front heater & cooling unit assembly. These motors rotate so that the air mix door is opened or closed to a position set by the front air control. Motor rotation is then conveyed through a shaft and the air mix door position is then fed back to the front air control by the PBR built into the air mix door motors.

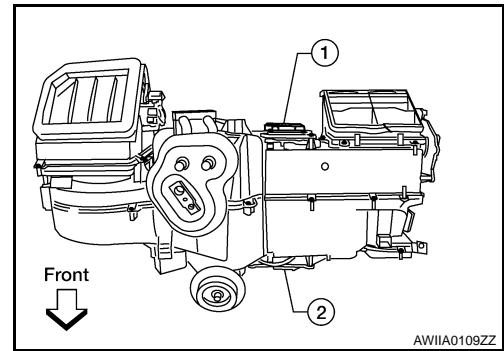

## Air Mix Door Motor Component Function Check

INFOID:000000001611797

HAC

### INSPECTION FLOW

#### 1. CONFIRM SYMPTOM BY PERFORMING OPERATIONAL CHECK - TEMPERATURE INCREASE

1. Turn the temperature control dial (driver) clockwise until 32°C (90°F) is displayed.
2. Check for hot air at discharge air outlets.

>> GO TO 2.

#### 2. CONFIRM SYMPTOM BY PERFORMING OPERATIONAL CHECK - TEMPERATURE DECREASE

1. Turn the temperature control dial (driver) counterclockwise until 18°C (60°F) is displayed.
2. Check for cold air at discharge air outlets.

Can a symptom be duplicated?

YES >> GO TO 4.

NO >> GO TO 3.

#### 3. PERFORM COMPLETE OPERATIONAL CHECK

Perform a complete operational check and check for any symptoms. Refer to [HAC-7, "Operational Check"](#).

Can a symptom be duplicated?

YES >> Refer to [HAC-6, "How to Perform Trouble Diagnosis For Quick And Accurate Repair"](#).

NO >> System OK.

#### 4. CHECK FOR SERVICE BULLETINS

Check for any service bulletins.

>> GO TO 5.

#### 5. CHECK AIR MIX DOOR OPERATION

Check and verify air mix door mechanism for smooth operation from 18°C (60°F) to 32°C (90°F) in each mode.

# AIR MIX DOOR MOTOR

[AUTOMATIC AIR CONDITIONER]

## < COMPONENT DIAGNOSIS >

Is the inspection result normal?

- YES >> GO TO 6.
- NO >> Repair as necessary.

### 6. PERFORM SELF-DIAGNOSIS

Perform self-diagnosis to check for any codes. Refer to [HAC-21, "Front Air Control Self-Diagnosis"](#).

Are any self-diagnosis codes present?

- YES >> Refer to [HAC-21, "Front Air Control Self-Diagnosis Code Chart"](#).
- NO >> GO TO 7.

### 7. CHECK THE AIR MIX DOOR MOTOR PBR CIRCUIT

Perform diagnostic procedure for the air mix door motors. Refer to [HAC-29, "Air Mix Door Motor Component Function Check"](#).

Is the inspection result normal?

- YES >> GO TO 8.
- NO >> Repair PBR circuit or replace air mix door motor. Refer to [VTL-20, "Removal and Installation"](#).

### 8. RECHECK FOR CODES

Perform self-diagnosis. Refer to [HAC-21, "Front Air Control Self-Diagnosis"](#).

Are any self-diagnostic codes present?

- YES >> Refer to [HAC-21, "Front Air Control Self-Diagnosis Code Chart"](#).
- NO >> GO TO 9.

### 9. RECHECK FOR ANY SYMPTOMS

Perform a complete operational check for any symptoms. Refer to [HAC-7, "Operational Check"](#).

Does another symptom exist?

- YES >> Refer to [HAC-6, "How to Perform Trouble Diagnosis For Quick And Accurate Repair"](#).
- NO >> Replace front air control Refer to [VTL-8, "Removal and Installation"](#).

## Air Mix Door Motor (Driver) Diagnosis Procedure

INFOID:000000001611798

SYMPTOM:

- Discharge air temperature does not change.
- Air mix door motor does not operate.

## DIAGNOSTIC PROCEDURE FOR AIR MIX DOOR MOTOR (DRIVER)

### 1. CHECK FRONT AIR CONTROL FOR POWER AND GROUND

1. Turn ignition switch ON.
2. Rotate temperature control dial (driver) to 32°C (90°F).
3. Check voltage between front air control harness connector M49 terminal 17 and terminal 18 while rotating temperature control dial (driver) to 18°C (60°F).

Connector	Terminals		Condition	Voltage (Approx.)
	(+)	(-)		
Front air control: M49	17	18	Rotate temp control dial	Battery voltage

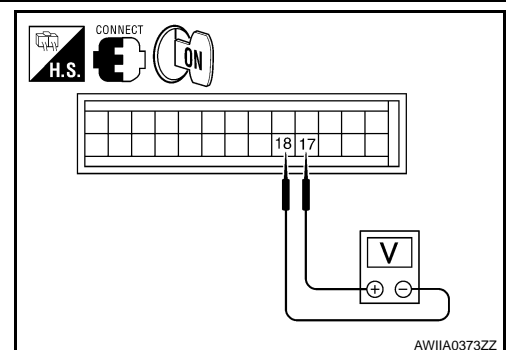

Is the inspection result normal?

- YES >> GO TO 4.
- NO >> GO TO 3.

### 2. CHECK AIR MIX DOOR MOTOR (DRIVER) CIRCUITS FOR SHORT TO GROUND

# AIR MIX DOOR MOTOR

## < COMPONENT DIAGNOSIS >

## [AUTOMATIC AIR CONDITIONER]

1. Turn ignition switch OFF.
2. Disconnect the front air control harness connector.
3. Check continuity between front air control harness connector M49 terminal 17, 18 and ground.

**17 - Ground : Continuity should not exist.**  
**18 - Ground : Continuity should not exist.**

Is the inspection result normal?

YES >> Replace front air control. Refer to [VTL-8, "Removal and Installation"](#).

NO >> Repair or replace harness as necessary.

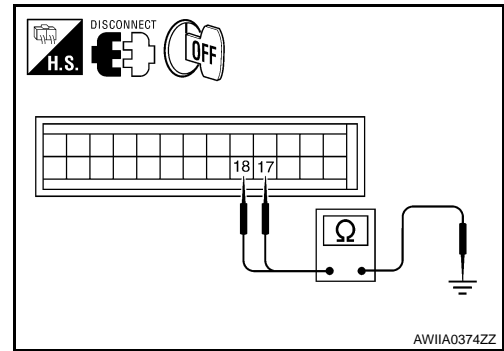

AWIIA0374ZZ

### 3.CHECK FRONT AIR CONTROL FOR POWER AND GROUND

1. Turn ignition switch ON.
2. Rotate temperature control dial (driver) to 32°C (90°F).
3. Check voltage between front air control harness connector M49 terminal 17 and terminal 18 while rotating temperature control dial (driver) to 18°C (60°F).

Connector	Terminals		Condition	Voltage (Approx.)
	(+)	(-)		
Front air control: M49	18	17	Rotate temp control dial	Battery voltage

Is the inspection result normal?

YES >> GO TO 5.

NO >> Replace front air control. Refer to [VTL-8, "Removal and Installation"](#).

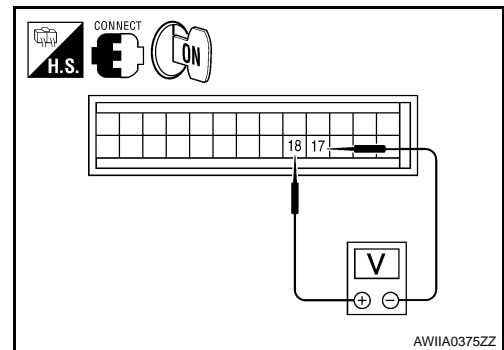

AWIIA0375ZZ

### 4.CHECK AIR MIX DOOR MOTOR (DRIVER) CIRCUITS FOR OPEN

1. Turn ignition switch OFF.
2. Disconnect the front air control harness connector.
3. Check continuity between front air control harness connector M49 terminal 17 and terminal 18.

**Continuity should exist.**

Is the inspection result normal?

YES >> GO TO 7.

NO >> GO TO 6.

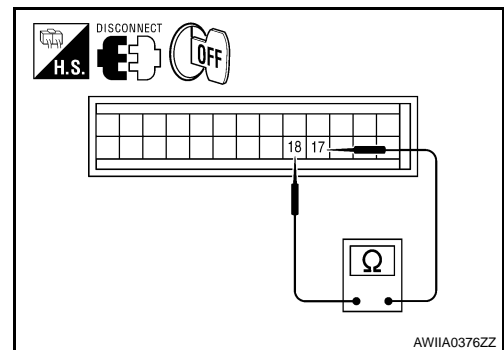

AWIIA0376ZZ

### 5.CHECK AIR MIX DOOR MOTOR (DRIVER) CIRCUITS FOR OPEN

1. Disconnect the air mix door motor (driver) harness connector.
2. Check continuity between front air control harness connector M49 (A) terminal 17, 18 and the air mix door motor (driver) harness connector M147 (B) terminal 1, 6.

**17 - 1 : Continuity should exist.**  
**18 - 6 : Continuity should exist.**

Is the inspection result normal?

YES >> Replace air mix door motor (driver). Refer to [VTL-20, "Removal and Installation"](#).

NO >> Repair or replace harness as necessary.

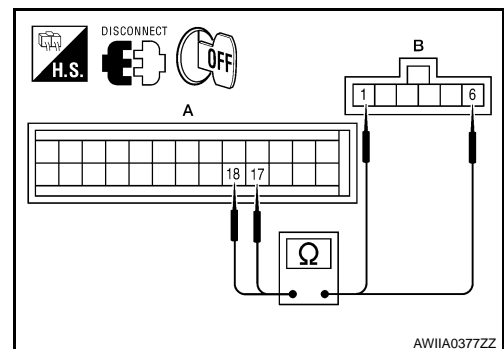

AWIIA0377ZZ

### 6.CHECK FRONT AIR CONTROL FOR PBR POWER AND GROUND

# AIR MIX DOOR MOTOR

[AUTOMATIC AIR CONDITIONER]

## < COMPONENT DIAGNOSIS >

1. Reconnect front air control harness connector.
2. Turn ignition switch ON.
3. Check voltage between front air control harness connector M50 (A) terminal 28 and M49 (B) terminal 3.

Connector	Terminals		Voltage (Approx.)
	(+)	(-)	
Front air control: M50, M49	28	3	5V

Is the inspection result normal?

- YES >> GO TO 9.  
NO >> GO TO 8.

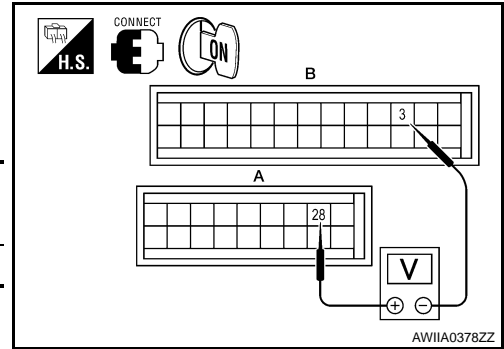

## 7. CHECK PBR REFERENCE VOLTAGE CIRCUIT FOR SHORT TO GROUND

1. Turn ignition switch OFF.
2. Disconnect the front air control harness connector.
3. Check continuity between front air control harness connector M50 terminal 28 and ground.

**Continuity should not exist.**

Is the inspection result normal?

- YES >> Replace front air control. Refer to [VTL-8. "Removal and Installation"](#).  
NO >> Repair or replace harness as necessary.

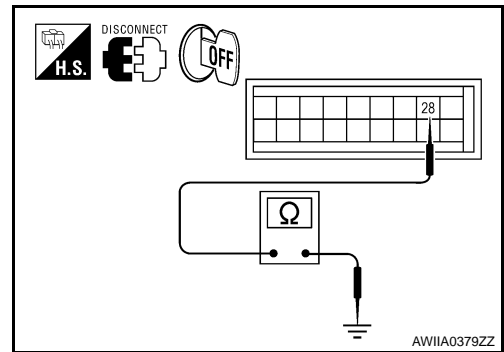

## 8. CHECK PBR REFERENCE VOLTAGE AND GROUND CIRCUITS

1. Turn ignition switch OFF.
2. Disconnect the front air control harness connector.
3. Check continuity between front air control harness connector M50 (A) terminal 28 and M49 (B) terminal 3.

**Continuity should exist.**

Is the inspection result normal?

- YES >> GO TO 11.  
NO >> GO TO 10.

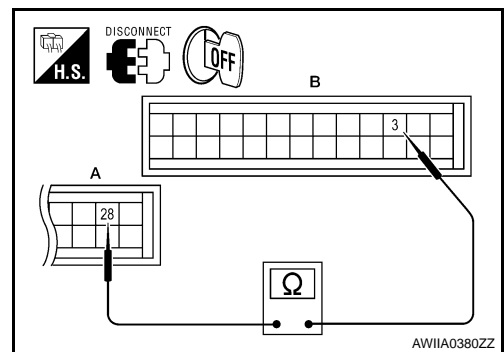

## 9. CHECK PBR REFERENCE VOLTAGE CIRCUIT FOR OPEN

1. Disconnect the air mix door motor (driver) harness connector.
2. Check continuity between air mix door motor (driver) harness connector M147 (B) terminal 3, 2 and front air control harness connector M49 (C) terminal 3 and M50 (A) terminal 28.

**28 - 3 : Continuity should exist.**

**3 - 2 : Continuity should exist.**

Is the inspection result normal?

- YES >> Replace air mix door motor (driver). Refer to [VTL-20. "Removal and Installation"](#).  
NO >> Repair or replace harness as necessary.

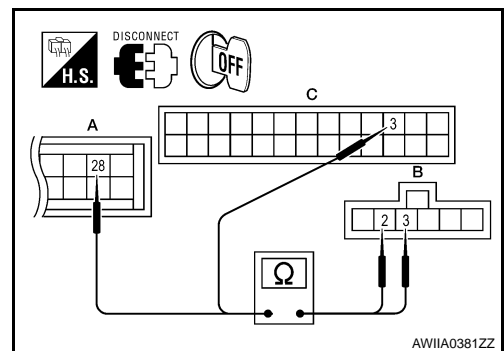

## 10. CHECK PBR FEEDBACK VOLTAGE



# AIR MIX DOOR MOTOR

[AUTOMATIC AIR CONDITIONER]

## < COMPONENT DIAGNOSIS >

1. Reconnect the front air control harness connector.
2. Turn ignition switch ON.
3. Check voltage between front air control harness connector M49 terminal 6 and ground while rotating temperature control dial from 32°C (90°F) to 18°C (60°F).

**Voltage** : **Approx. .5V - 4.5V**

Is the inspection result normal?

- YES >> GO TO 13.  
NO >> GO TO 12.

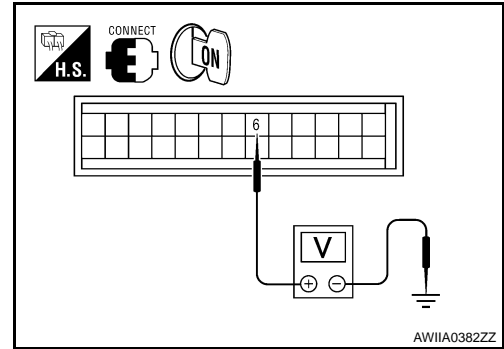

## 11. CHECK PBR FEEDBACK SIGNAL CIRCUIT FOR SHORT TO GROUND

1. Turn ignition switch OFF.
2. Disconnect front air control harness connector.
3. Check continuity between front air control harness connector M49 terminal 6 and ground.

**Continuity should not exist.**

Is the inspection result normal?

- YES >> Replace front air control. Refer to [VTL-8, "Removal and Installation"](#).  
NO >> Repair or replace harness as necessary.

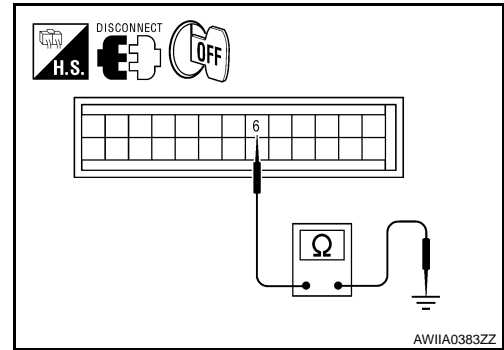

## 12. CHECK PBR FEEDBACK CIRCUIT FOR OPEN

1. Turn ignition switch OFF.
2. Disconnect the air mix door motor (driver) harness connector and front air control harness connector.
3. Check continuity between air mix door motor (driver) harness connector M147 (B) terminal 4 and front air control harness connector M49 (A) terminal 6.

**Continuity should exist.**

Is the inspection result normal?

- YES >> Replace air mix door motor (driver). Refer to [VTL-20, "Removal and Installation"](#).  
NO >> Repair or replace harness as necessary.

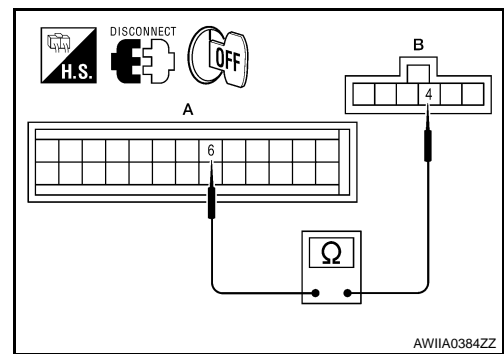

## Air Mix Door Motor (Passenger) Diagnosis Procedure

INFOID:000000001611799

SYMPTOM:

- Discharge air temperature does not change.
- Air mix door motor does not operate.

## DIAGNOSTIC PROCEDURE FOR AIR MIX DOOR MOTOR (PASSENGER)

### 1. CHECK FRONT AIR CONTROL FOR POWER AND GROUND

# AIR MIX DOOR MOTOR

[AUTOMATIC AIR CONDITIONER]

## < COMPONENT DIAGNOSIS >

1. Turn ignition switch ON.
2. Rotate temperature control dial (passenger) to 32°C (90°F).
3. Check voltage between front air control harness connector M49 terminal 14 and terminal 2 while rotating temperature control dial (passenger) to 18° C (60° F).

Connector	Terminals		Condition	Voltage (Approx.)
	(+)	(-)		
Front air control: M49	2	14	Rotate temp control dial	Battery voltage

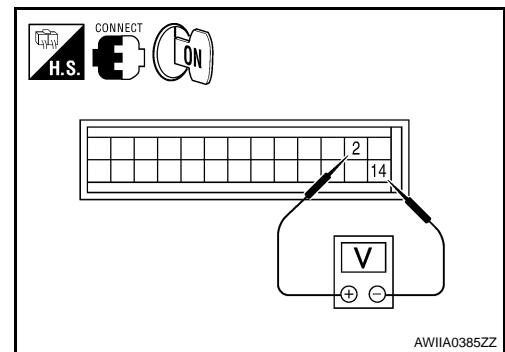

Is the inspection result normal?

- OK >> GO TO 4.  
 NG >> GO TO 3.

## 2.CHECK AIR MIX DOOR MOTOR (PASSENGER) CIRCUITS FOR SHORT TO GROUND

1. Turn ignition switch OFF.
2. Disconnect the front air control harness connector.
3. Check continuity between front air control harness connector M49 terminal 14, 2 and ground.

- 14 - Ground : Continuity should not exist.**  
**2 - Ground : Continuity should not exist.**

Is the inspection result normal?

- YES >> Replace front air control. Refer to [VTL-8. "Removal and Installation"](#).  
 NO >> Repair or replace harness as necessary.

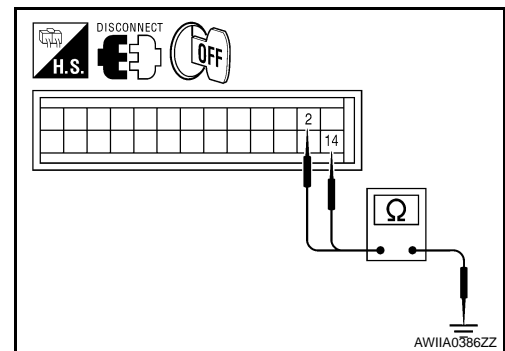

## 3.CHECK FRONT AIR CONTROL FOR POWER AND GROUND

1. Turn ignition switch ON.
2. Rotate temperature control dial (passenger) to 18°C (60°F).
3. Check voltage between front air control harness connector M49 terminal 14 and terminal 2 while rotating temperature control dial (passenger) to 32°C (90°F).

Connector	Terminals		Condition	Voltage (Approx.)
	(+)	(-)		
Front air control: M49	14	2	Rotate temp control dial	Battery voltage

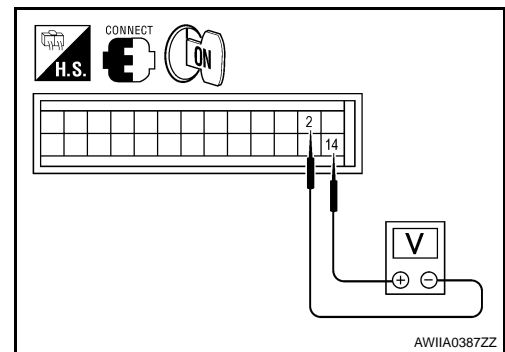

Is the inspection result normal?

- YES >> GO TO 5.  
 NO >> Replace front air control. Refer to [VTL-8. "Removal and Installation"](#).

## 4.CHECK AIR MIX DOOR MOTOR (PASSENGER) CIRCUITS FOR OPEN

1. Turn ignition switch OFF.
2. Disconnect the front air control harness connector.
3. Check continuity between front air control harness connector M50 terminal 14 and terminal 2.

**Continuity should exist.**

Is the inspection result normal?

- YES >> GO TO 7.  
 NO >> GO TO 6.

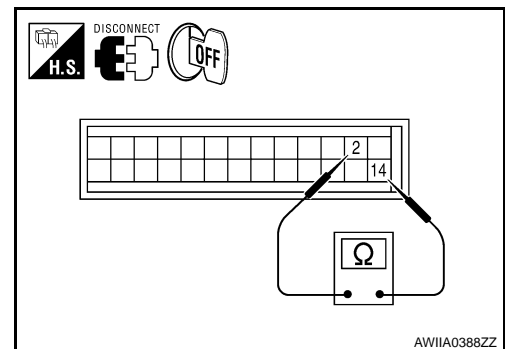

## 5.CHECK AIR MIX DOOR MOTOR (PASSENGER) CIRCUITS FOR OPEN

# AIR MIX DOOR MOTOR

## < COMPONENT DIAGNOSIS >

## [AUTOMATIC AIR CONDITIONER]

1. Disconnect the air mix door motor (passenger) harness connector.
2. Check continuity between front air control harness connector M49 terminal 14, 2 and the air mix door motor (passenger) harness connector M143 terminal 1, 6.

**14 - 1 : Continuity should exist.**  
**2 - 6 : Continuity should exist.**

Is the inspection result normal?

YES >> Replace air mix door motor (passenger). Refer to [VTL-20, "Removal and Installation"](#).

NO >> Repair or replace harness as necessary.

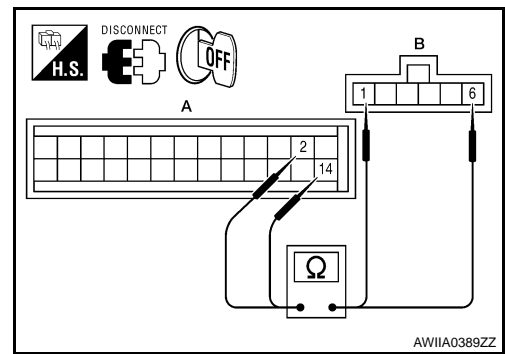

## 6. CHECK FRONT AIR CONTROL FOR PBR POWER AND GROUND

1. Reconnect front air control harness connector.
2. Turn ignition switch ON.
3. Check voltage between front air control harness connector M50 (A) terminal 28 and M49 (B) terminal 3.

Connector	Terminals		Voltage (Approx.)
	(+)	(-)	
Front air control: M49	28	3	5V

Is the inspection result normal?

YES >> GO TO 9.

NO >> GO TO 8.

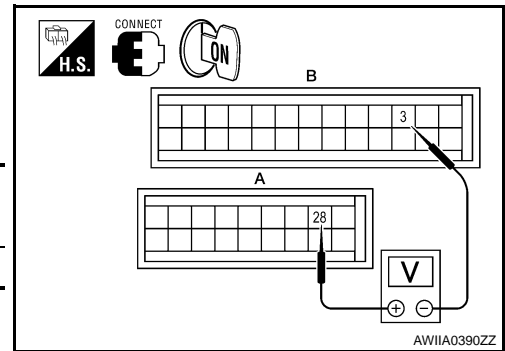

## 7. CHECK PBR REFERENCE VOLTAGE CIRCUIT FOR SHORT TO GROUND

1. Turn ignition switch OFF.
2. Disconnect the front air control harness connector.
3. Check continuity between front air control harness connector M49 terminal 29 and ground.

**Continuity should not exist.**

Is the inspection result normal?

YES >> Replace front air control. Refer to [VTL-8, "Removal and Installation"](#).

NO >> Repair or replace harness as necessary.

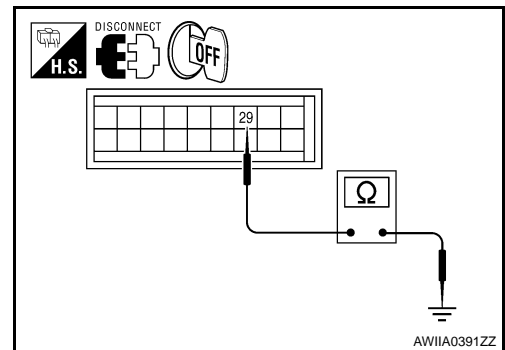

## 8. CHECK PBR REFERENCE VOLTAGE AND GROUND CIRCUITS

1. Turn ignition switch OFF.
2. Disconnect the front air control harness connector.
3. Check continuity between front air control harness connector M50 (A) terminal 28 and M49 (B) terminal 3.

**Continuity should exist.**

Is the inspection result normal?

YES >> GO TO 11.

NO >> GO TO 10.

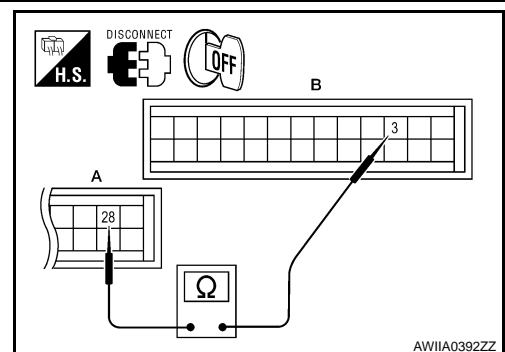

## 9. CHECK PBR REFERENCE VOLTAGE CIRCUIT FOR OPEN

A  
B  
C  
D  
E  
F  
G  
H  
J  
K  
L  
M  
N  
O  
P

HAC

# AIR MIX DOOR MOTOR

[AUTOMATIC AIR CONDITIONER]

## < COMPONENT DIAGNOSIS >

1. Disconnect the air mix door motor (passenger) harness connector.
2. Check continuity between air mix door motor (passenger) harness connector M143 (B) terminal 3, 2 and front air control harness connector M49 (C) terminal 3 and M50 terminal 28.

**28 - 3 : Continuity should exist.**

**3 - 2 : Continuity should exist.**

Is the inspection result normal?

YES >> Replace air mix door motor (passenger). Refer to [VTL-20, "Removal and Installation"](#).

NO >> Repair or replace harness as necessary.

## 10. CHECK PBR FEEDBACK VOLTAGE

1. Reconnect the front air control harness connector.
2. Turn ignition switch ON.
3. Check voltage between front air control harness connector M50 terminal 29 and ground while rotating temperature control dial (passenger) from 32°C (90° F) to 18° (60° F).

**Voltage : Approx. .5V - 4.5V**

Is the inspection result normal?

YES >> GO TO 13.

NO >> GO TO 12.

## 11. CHECK PBR FEEDBACK SIGNAL CIRCUIT FOR SHORT TO GROUND

1. Turn ignition switch OFF.
2. Disconnect front air control harness connector.
3. Check continuity between front air control harness connector M50 terminal 29 and ground.

**Continuity should not exist.**

Is the inspection result normal?

YES >> Replace front air control. Refer to [VTL-8, "Removal and Installation"](#).

NO >> Repair or replace harness as necessary.

## 12. CHECK PBR FEEDBACK CIRCUIT FOR OPEN

1. Turn ignition switch OFF.
2. Disconnect the air mix door motor (passenger) harness connector and front air control harness connector.
3. Check continuity between air mix door motor (passenger) harness connector M143 terminal 4 and front air control harness connector M50 terminal 29.

**Continuity should exist.**

Is the inspection result normal?

YES >> Replace air mix door motor (passenger). Refer to [VTL-20, "Removal and Installation"](#).

NO >> Repair or replace harness as necessary.

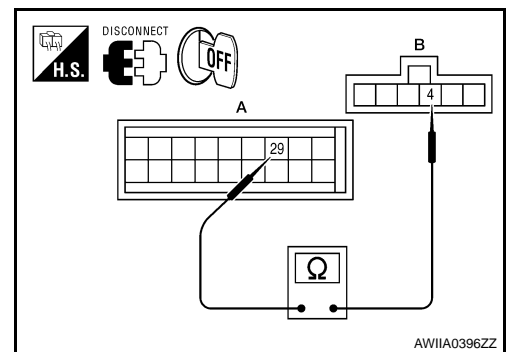
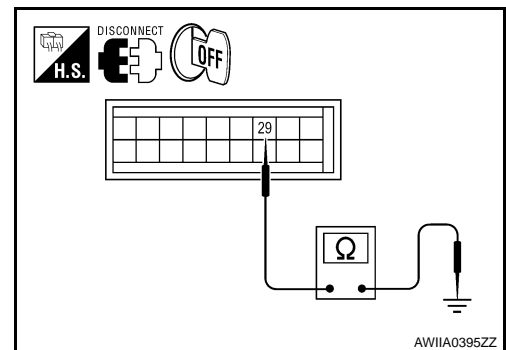
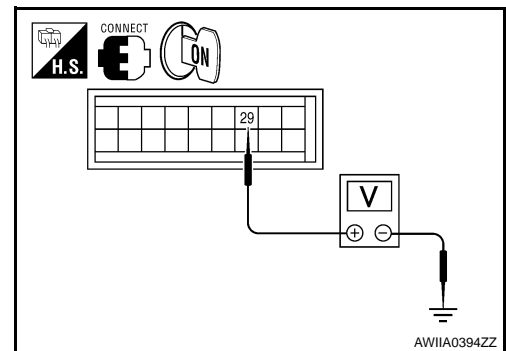
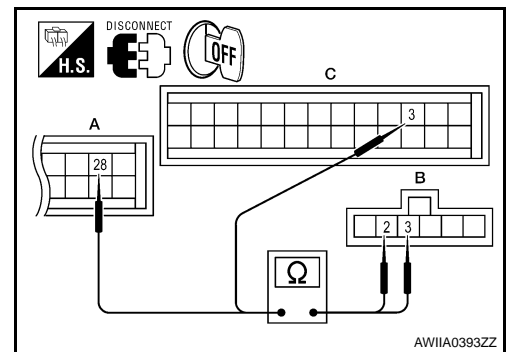

# INTAKE DOOR MOTOR

< COMPONENT DIAGNOSIS >

[AUTOMATIC AIR CONDITIONER]

## INTAKE DOOR MOTOR

### System Description

INFOID:000000001611800

### SYSTEM DESCRIPTION

#### SYMPTOM:

- Intake door motor does not operate normally.
- Intake door does not change.

### SYSTEM DESCRIPTION

#### Component Parts

Intake door control system components are:

- Front air control
- Intake door motor (PRB built into the intake door motor)
- In-vehicle sensor
- Ambient sensor
- Optical sensor
- Intake sensor

#### System Operation

The intake door control determines the intake door position based on the position of the recirculation switch. When the recirculation switch is depressed the intake door motor rotates closing off the fresh air inlet and recirculating the cabin air. If the recirculation switch is depressed again, the intake door motor rotates in the opposite direction, again allowing fresh air into the cabin.

In the AUTO mode, the front air control determines the intake door position based on the ambient temperature, the intake air temperature and the in-vehicle temperature. When the DEF, D/F, FLOOR or OFF switches are pushed, the front air control sets the intake door at the fresh position.

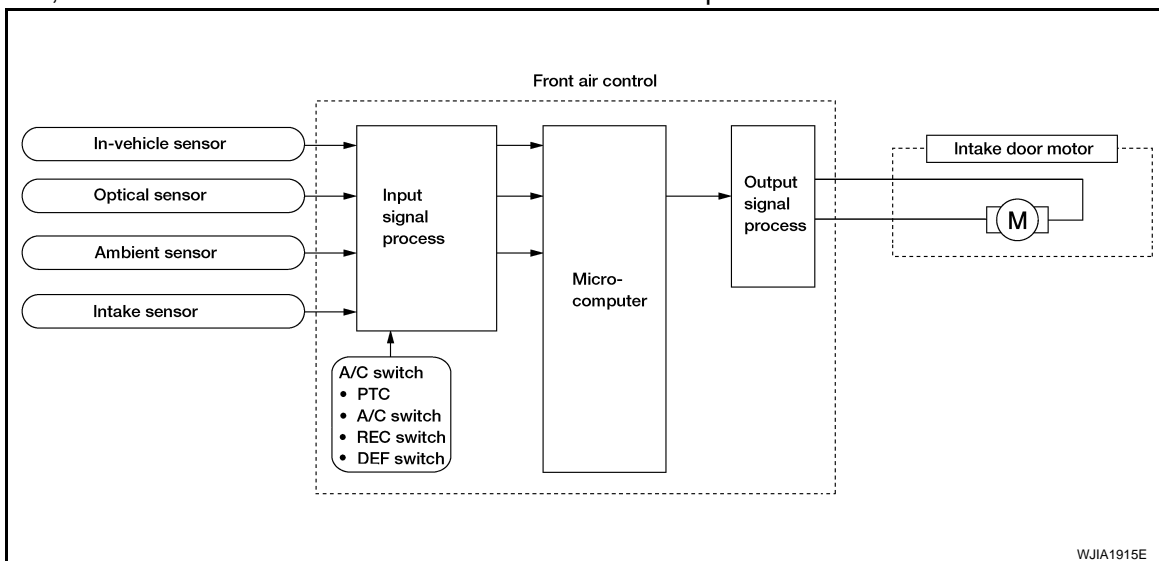

#### Intake Door Control Specification

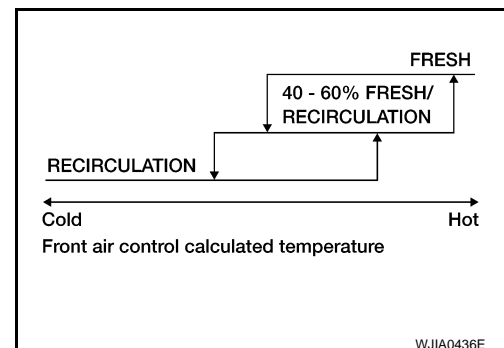

### COMPONENT DESCRIPTION

# INTAKE DOOR MOTOR

< COMPONENT DIAGNOSIS >

[AUTOMATIC AIR CONDITIONER]

Intake door motor

The intake door motor is attached to the intake unit. It rotates so that air is drawn from inlets set by the front air control. Motor rotation is conveyed to a lever which activates the intake door.

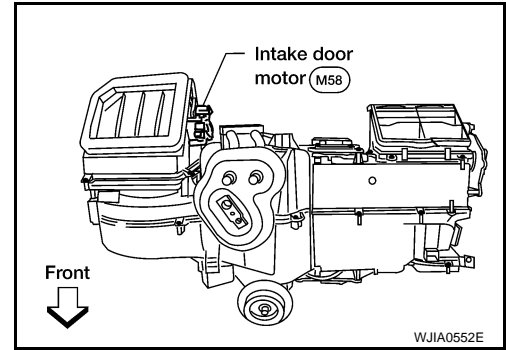





## Intake Door Motor Component Function Check

INFOID:000000001611801

### INSPECTION FLOW

#### 1. CONFIRM SYMPTOM BY PERFORMING OPERATIONAL CHECK - REC ( )

1. Press the mode switch to vent mode (  ).
2. Press REC (  ) switch. The REC (  ) indicator should illuminate.
3. Press REC (  ) switch again. The REC (  ) indicator should go out.
4. Listen for intake door position change (you should hear blower sound change slightly).

Can a symptom be duplicated?

- YES >> GO TO 3.
- NO >> GO TO 2.

#### 2. PERFORM COMPLETE OPERATIONAL CHECK

Perform a complete operational check and check for any symptoms. Refer to [HAC-7, "Operational Check"](#).

Can a symptom be duplicated?

- YES >> Refer to [HAC-6, "How to Perform Trouble Diagnosis For Quick And Accurate Repair"](#).
- NO >> System OK.

#### 3. CHECK FOR SERVICE BULLETINS

Check for any service bulletins.

>> GO TO 4.

#### 4. CHECK INTAKE DOOR OPERATION

Check and verify intake door mechanism for smooth operation.

Is the inspection result normal?

- YES >> GO TO 5.
- NO >> Repair intake door mechanism.

#### 5. PERFORM SELF-DIAGNOSIS

Perform self-diagnosis to check for any codes. Refer to [HAC-21, "Front Air Control Self-Diagnosis"](#).

Are any self-diagnosis codes present?

- YES >> Refer to [HAC-21, "Front Air Control Self-Diagnosis Code Chart"](#).
- NO >> GO TO 6.

#### 6. RECHECK FOR ANY SYMPTOMS

Perform a complete operational check for any symptoms. Refer to [HAC-7, "Operational Check"](#).

Does another symptom exist?

- YES >> Refer to [HAC-6, "How to Perform Trouble Diagnosis For Quick And Accurate Repair"](#).
- NO >> Replace front air control. Refer to [VTL-8, "Removal and Installation"](#).

# INTAKE DOOR MOTOR

[AUTOMATIC AIR CONDITIONER]

< COMPONENT DIAGNOSIS >

INFOID:000000001611802

## Intake Door Motor Diagnosis Procedure

SYMPTOM:

- Intake door does not change.
- Intake door motor does not operate normally.

### DIAGNOSTIC PROCEDURE FOR INTAKE DOOR MOTOR

#### 1. CHECK FRONT AIR CONTROL FOR POWER AND GROUND

1. Turn ignition switch ON.
2. Check voltage between front air control harness connector M49 terminal 21 and terminal 22 while placing the HVAC system into self-diagnostic mode.

Connector	Terminals		Condition	Voltage (Approx.)
	(+)	(-)		
Front air control: M49	21	22	Self-diagnostic mode	Battery voltage

Is the inspection result normal?

- OK >> GO TO 4.  
NO >> GO TO 3.

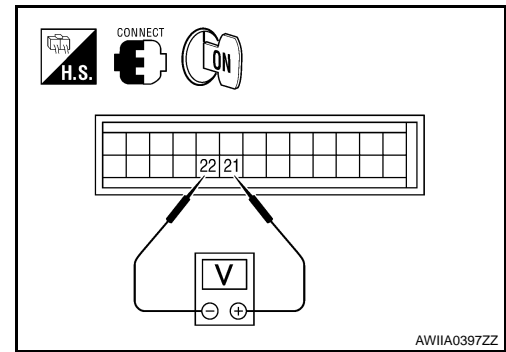

#### 2. CHECK INTAKE DOOR MOTOR CIRCUITS FOR SHORT TO GROUND

1. Turn ignition switch OFF.
2. Disconnect the front air control harness connector.
3. Check continuity between front air control harness connector M49 terminal 21, 22 and ground.

- 21 - Ground : Continuity should not exist.**  
**22 - Ground : Continuity should not exist.**

Is the inspection result normal?

- OK >> Replace front air control. Refer to [VTL-8, "Removal and Installation"](#).  
NO >> Repair or replace harness as necessary.

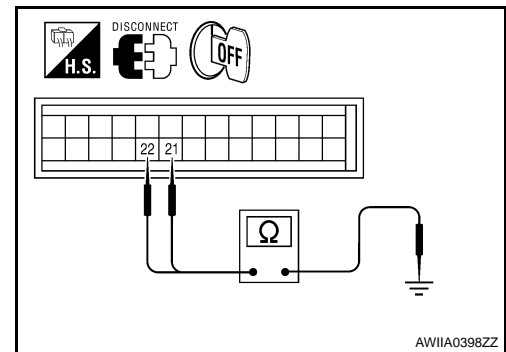

#### 3. CHECK FRONT AIR CONTROL FOR GROUND AND POWER

1. Press the BACK button to back out of self-diagnostic mode.
2. Check voltage between front air control harness connector M49 terminal 21 and terminal 22 while placing the HVAC system into self-diagnostic mode.

Connector	Terminals		Condition	Voltage (Approx.)
	(+)	(-)		
Front air control: M49	22	21	Self-diagnostic mode	Battery voltage

Is the inspection result normal?

- OK >> GO TO 5.  
NO >> Replace front air control. Refer to [VTL-8, "Removal and Installation"](#).

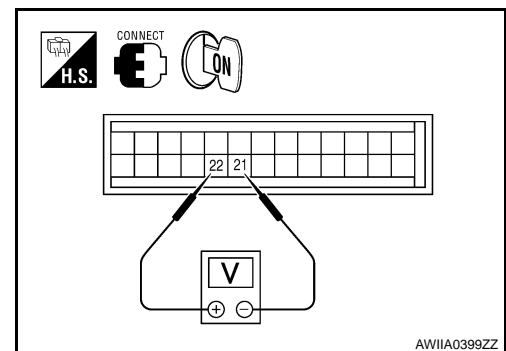

#### 4. CHECK INTAKE DOOR MOTOR AND CIRCUITS FOR OPEN

A  
B  
C  
D  
E  
F  
G  
H  
HAC  
J  
K  
L  
M  
N  
O  
P

# INTAKE DOOR MOTOR

[AUTOMATIC AIR CONDITIONER]

## < COMPONENT DIAGNOSIS >

1. Turn ignition switch OFF.
2. Disconnect the front air control harness connector.
3. Check continuity between front air control harness connector M49 terminal 21 and terminal 22.

**Continuity should exist.**

Is the inspection result normal?

- OK >> Replace intake door motor. Refer to [VTL-18, "Removal and Installation"](#).
- NO >> GO TO 6.

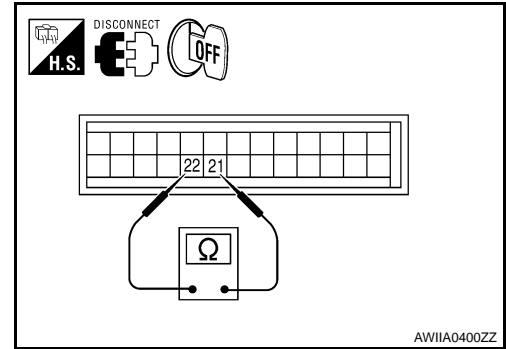

## 5. CHECK INTAKE DOOR MOTOR CIRCUITS FOR OPEN

1. Disconnect the intake door motor harness connector.
2. Check continuity between front air control harness connector M49 (A) terminal 21, 22 and the intake door motor harness connector M58 (B) terminal 1, 6.

**21 - 6 : Continuity should exist.**

**22 - 1 : Continuity should exist.**

Is the inspection result normal?

- YES >> Replace intake door motor. Refer to [VTL-18, "Removal and Installation"](#).
- NO >> Repair or replace harness as necessary.

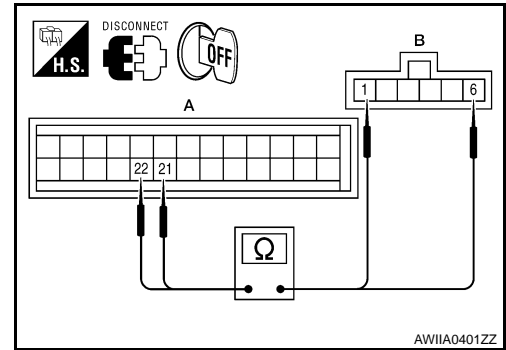



# DEFROSTER DOOR MOTOR CIRCUIT

< COMPONENT DIAGNOSIS >

[AUTOMATIC AIR CONDITIONER]

## DEFROSTER DOOR MOTOR CIRCUIT

### System Description

INFOID:000000001611803

### SYSTEM DESCRIPTION

#### Component Parts

Defroster door control system components are:

- Front air control
- Defroster door motor
- PBR (Built into defroster door motor)
- In-vehicle sensor
- Ambient sensor
- Optical sensor
- Intake sensor

#### System Operation

The front air control determines defroster door position based on the position of the defroster switch. When the defroster switch is depressed, the defroster door motor rotates directing air to the defroster ducts. When any mode other than defroster is selected, the defroster motor rotates in the opposite direction closing off air flow to the defroster ducts.

In the AUTO mode, the front air control determines defroster door position based on the ambient temperature, the intake air temperature and the in-vehicle temperature.

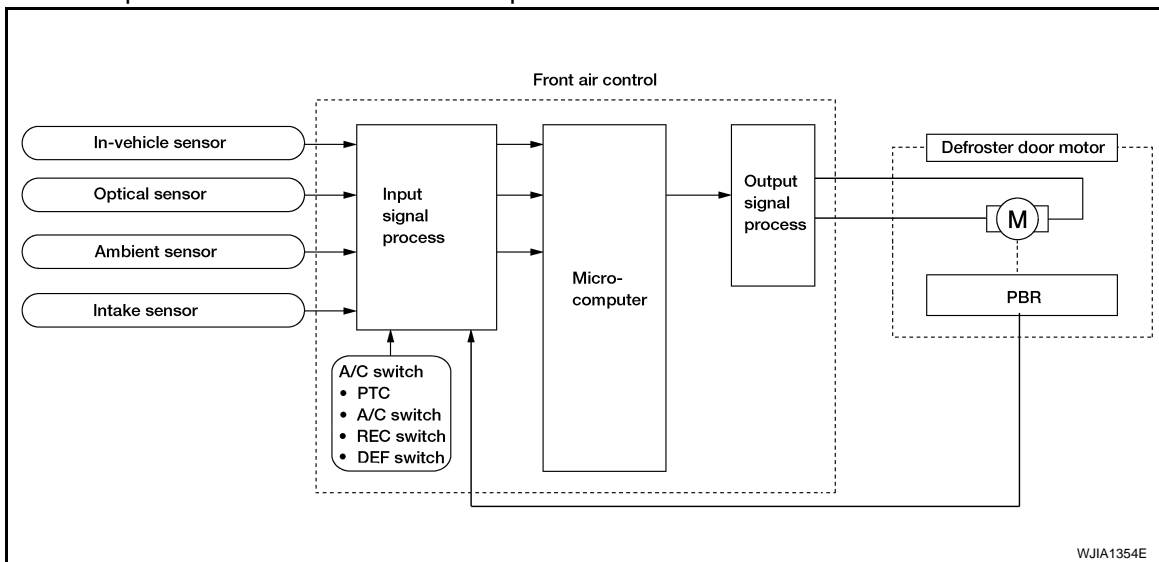

### COMPONENT DESCRIPTION

#### Defroster door motor

The defroster door motor is attached to the front heater & cooling unit assembly. The front air control sends a voltage to rotate to the defroster door directing the air flow either to the defroster ducts, or to the floor ducts, depending on which way the voltage and ground are applied to the motor leads. Motor rotation is conveyed to a lever which activates the defroster door.

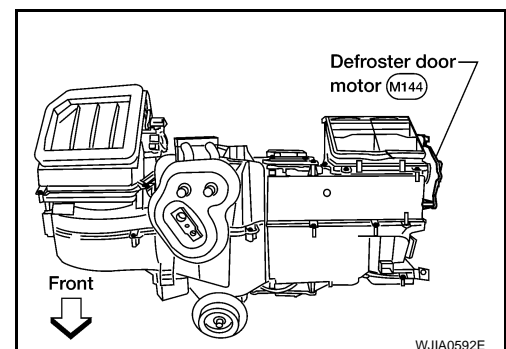

### Defroster Door Motor Component Function Check

INFOID:000000001611804

### INSPECTION FLOW



A  
B  
C  
D  
E  
F  
G  
H  
HAC  
J  
K  
L  
M  
N  
O  
P

# DEFROSTER DOOR MOTOR CIRCUIT

[AUTOMATIC AIR CONDITIONER]

< COMPONENT DIAGNOSIS >

## 1. CONFIRM SYMPTOM BY PERFORMING OPERATIONAL CHECK - DEFROSTER DOOR

1. Select vent (  ) mode.
2. Press the defrost switch (  ). Defroster indicator should illuminate.
3. Listen for defroster door position change (blower sound should change slightly).

Can the symptom be duplicated?

- YES >> GO TO 3.  
NO >> GO TO 2.

## 2. CHECK FOR ANY SYMPTOMS

Perform a complete operational check for any symptoms. Refer to [HAC-7. "Operational Check"](#).

Does another symptom exist?

- YES >> Refer to [HAC-6. "How to Perform Trouble Diagnosis For Quick And Accurate Repair"](#).  
NO >> SYSTEM OK.

## 3. CHECK FOR SERVICE BULLETINS

Check for any service bulletins.

>> GO TO 4.

## 4. CHECK DEFROSTER DOOR MOTOR

Perform diagnostic procedure for defroster door motor. Refer to [HAC-41. "Defroster Door Motor Component Function Check"](#).

Is the inspection result normal?

- YES >> GO TO 5.  
NO >> Repair PBR circuit or replace defroster door motor. Refer to [VTL-17. "Removal and Installation"](#).

## 5. CHECK DEFROSTER DOOR OPERATION

Check and verify defroster door mechanism for smooth operation.

Is the inspection result normal?

- YES >> Replace defroster door motor. Refer to [VTL-17. "Removal and Installation"](#).  
NO >> Repair defroster door mechanism.

## Defroster Door Motor Diagnosis Procedure



INFOID:000000001611805

SYMPTOM:

- Defroster door does not change.
- Defroster door motor does not operate normally.

## DIAGNOSTIC PROCEDURE FOR DEFROSTER DOOR MOTOR

### 1. CHECK FRONT AIR CONTROL FOR POWER AND GROUND

1. Turn ignition switch ON.
2. Press the defroster switch (  ).
3. Check voltage between front air control harness connector M49 terminal 24 and terminal 23 and press the defroster switch (  ) again.

Connector	Terminals		Condition	Voltage (Approx.)
	(+)	(-)		
Front air control: M49	24	23	Press defroster switch	Battery voltage

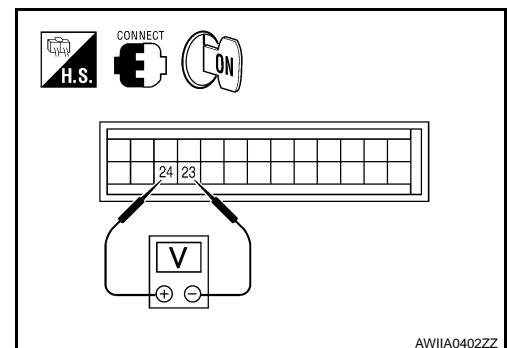

Is the inspection result normal?

- YES >> GO TO 4.  
NO >> GO TO 3.

# DEFROSTER DOOR MOTOR CIRCUIT

[AUTOMATIC AIR CONDITIONER]

< COMPONENT DIAGNOSIS >

## 2. CHECK DEFROSTER DOOR MOTOR CIRCUITS FOR SHORT TO GROUND

1. Turn ignition switch OFF.
2. Disconnect the front air control harness connector.
3. Check continuity between front air control harness connector M49 terminal 23, 24 and ground.

**23 - Ground : Continuity should not exist.**  
**24 - Ground : Continuity should not exist.**

Is the inspection result normal?

- YES >> Replace front air control. Refer to [VTL-8. "Removal and Installation"](#)  
 NO >> Repair or replace harness as necessary.

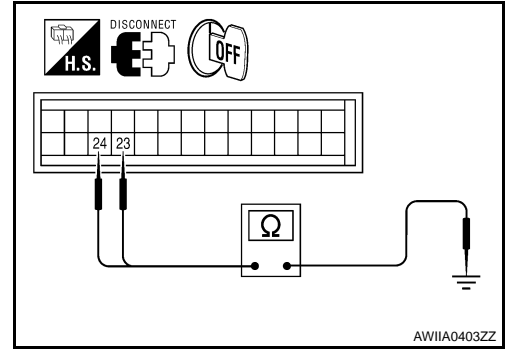

## 3. CHECK FRONT AIR CONTROL FOR GROUND AND POWER

1. Press the defroster switch (☐).
2. Check voltage between front air control harness connector M49 terminal 23 and terminal 24 and press the defroster switch (☐) again.

Connector	Terminals		Condition	Voltage (Approx.)
	(+)	(-)		
Front air control: M49	23	24	Press defroster switch	Battery voltage

Is the inspection result normal?

- YES >> GO TO 5.  
 NO >> Replace front air control. Refer to [VTL-8. "Removal and Installation"](#).

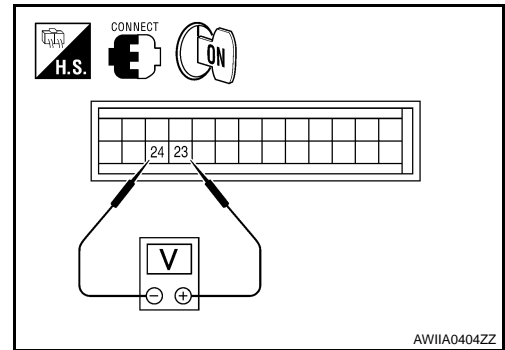

## 4. CHECK DEFROSTER DOOR MOTOR AND CIRCUITS FOR OPEN

1. Turn ignition switch OFF.
2. Disconnect the front air control harness connector.
3. Check continuity between front air control harness connector M49 terminal 23 and terminal 24.

**Continuity should exist.**

Is the inspection result normal?

- YES >> GO TO 7.  
 NO >> GO TO 6.

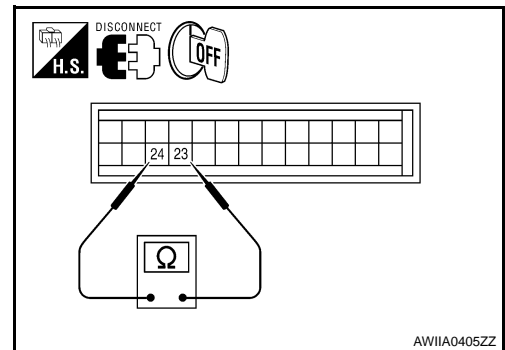

## 5. CHECK DEFROSTER DOOR MOTOR CIRCUITS FOR OPEN

1. Disconnect the defroster door motor harness connector.
2. Check continuity between front air control harness connector M49 terminal 23, 24 and the defroster door motor harness connector M144 terminal 1, 6.

**23 - 1 : Continuity should exist.**  
**24 - 6 : Continuity should exist.**

Is the inspection result normal?

- YES >> Replace defroster door motor. Refer to [VTL-17. "Removal and Installation"](#).  
 NO >> Repair or replace harness as necessary.

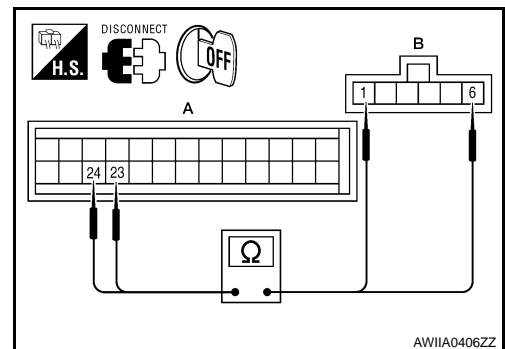

## 6. CHECK FRONT AIR CONTROL FOR PBR POWER AND GROUND

A  
B  
C  
D  
E  
F  
G  
H  
J  
K  
L  
M  
N  
O  
P

HAC

# DEFROSTER DOOR MOTOR CIRCUIT

[AUTOMATIC AIR CONDITIONER]

## < COMPONENT DIAGNOSIS >

1. Reconnect front air control harness connector.
2. Turn ignition switch ON.
3. Check voltage between front air control harness connector M50 (A) terminal 28 and M49 (B) terminal 3.

Connector	Terminals		Voltage (Approx.)
	(+)	(-)	
Front air control: M50, M49	28	3	5V

Is the inspection result normal?

- YES >> GO TO 9.  
NO >> GO TO 8.

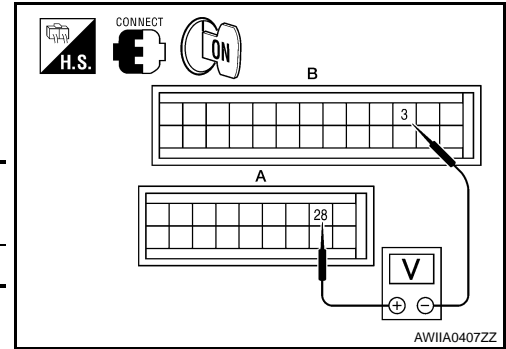

## 7. CHECK PBR REFERENCE VOLTAGE CIRCUIT FOR SHORT TO GROUND

1. Turn ignition switch OFF.
2. Disconnect the front air control harness connector.
3. Check continuity between front air control harness connector M50 terminal 28 and ground.

**Continuity should not exist.**

Is the inspection result normal?

- YES >> Replace front air control. Refer to [VTL-8. "Removal and Installation"](#).  
NO >> Repair or replace harness as necessary.

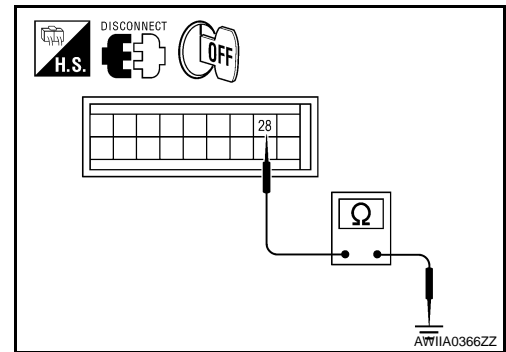

## 8. CHECK PBR REFERENCE VOLTAGE AND GROUND CIRCUITS

1. Turn ignition switch OFF.
2. Disconnect the front air control harness connector.
3. Check continuity between front air control harness connector M50 terminal 28 (A) and M49 (B) terminal 3.

**Continuity should exist.**

Is the inspection result normal?

- YES >> GO TO 11.  
NO >> GO TO 10.

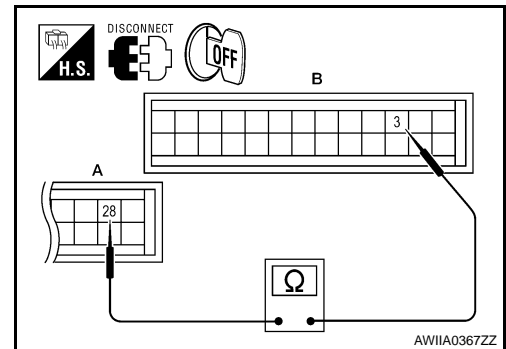

## 9. CHECK PBR REFERENCE VOLTAGE CIRCUIT FOR OPEN

1. Disconnect the defroster door motor harness connector.
2. Check continuity between defroster door motor harness connector M144 (B) terminal 3, 2 and front air control harness connector M50 (A) terminal 28, and M49 (C) terminal 3.

**28 - 3 : Continuity should exist.**

**3 - 2 : Continuity should exist.**

Is the inspection result normal?

- YES >> Replace defroster door motor. Refer to [VTL-17. "Removal and Installation"](#).  
NO >> Repair or replace harness as necessary.

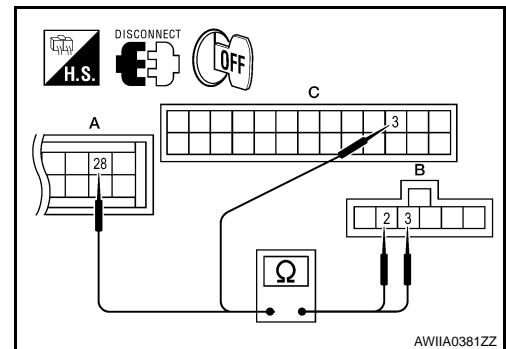

## 10. CHECK PBR FEEDBACK VOLTAGE

# DEFROSTER DOOR MOTOR CIRCUIT

[AUTOMATIC AIR CONDITIONER]

## < COMPONENT DIAGNOSIS >

1. Reconnect the front air control harness connector.
2. Turn ignition switch ON.
3. Check voltage between front air control harness connector M49 terminal 10 and ground while cycling defroster switch on and off.

**Voltage : Approx. 1V - 4.5V**

Is the inspection result normal?

- YES >> GO TO 13.  
NO >> GO TO 12.

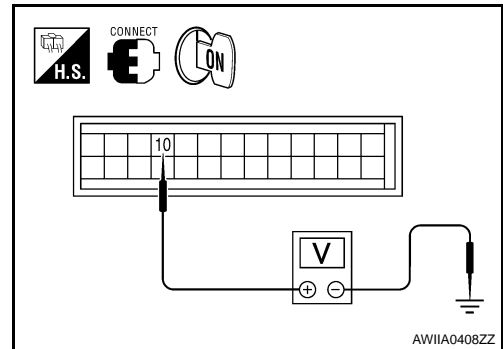

## 11. CHECK PBR FEEDBACK SIGNAL CIRCUIT FOR SHORT TO GROUND

1. Turn ignition switch OFF.
2. Disconnect front air control harness connector.
3. Check continuity between front air control harness connector M49 terminal 10 and ground.

**Continuity should not exist.**

Is the inspection result normal?

- YES >> Replace front air control. Refer to [VTL-8, "Removal and Installation"](#).  
NO >> Repair or replace harness as necessary.

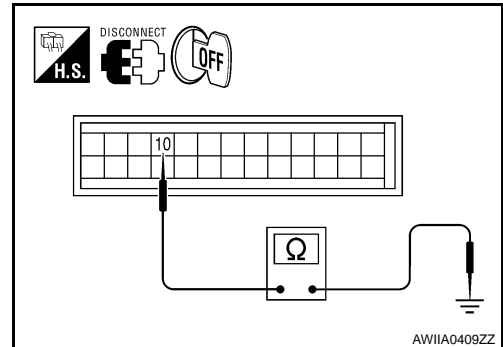

## 12. CHECK PBR FEEDBACK CIRCUIT FOR OPEN

1. Turn ignition switch OFF.
2. Disconnect the defroster door motor harness connector and front air control harness connector.
3. Check continuity between defroster door motor harness connector M144 (B) terminal 4 and front air control harness connector M49 (A) terminal 10

**Continuity should exist.**

Is the inspection result normal?

- YES >> Replace defroster door motor. Refer to [VTL-17, "Removal and Installation"](#).  
NO >> Repair or replace harness as necessary.

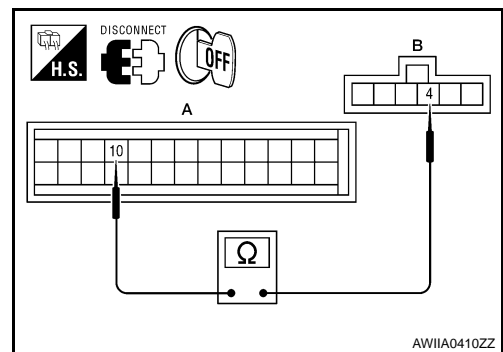

A  
B  
C  
D  
E  
F  
G  
H  
J  
K  
L  
M  
N  
O  
P

HAC

# BLOWER MOTOR CONTROL SYSTEM

< COMPONENT DIAGNOSIS >

[AUTOMATIC AIR CONDITIONER]

## BLOWER MOTOR CONTROL SYSTEM

### System Description

INFOID:000000001611806

### SYSTEM DESCRIPTION

#### Component Parts

Blower speed control system components are:

- Front air control
- Variable blower control
- Front blower motor relay
- Front blower motor
- In-vehicle sensor
- Ambient sensor
- Optical sensor
- Intake sensor

#### System Operation

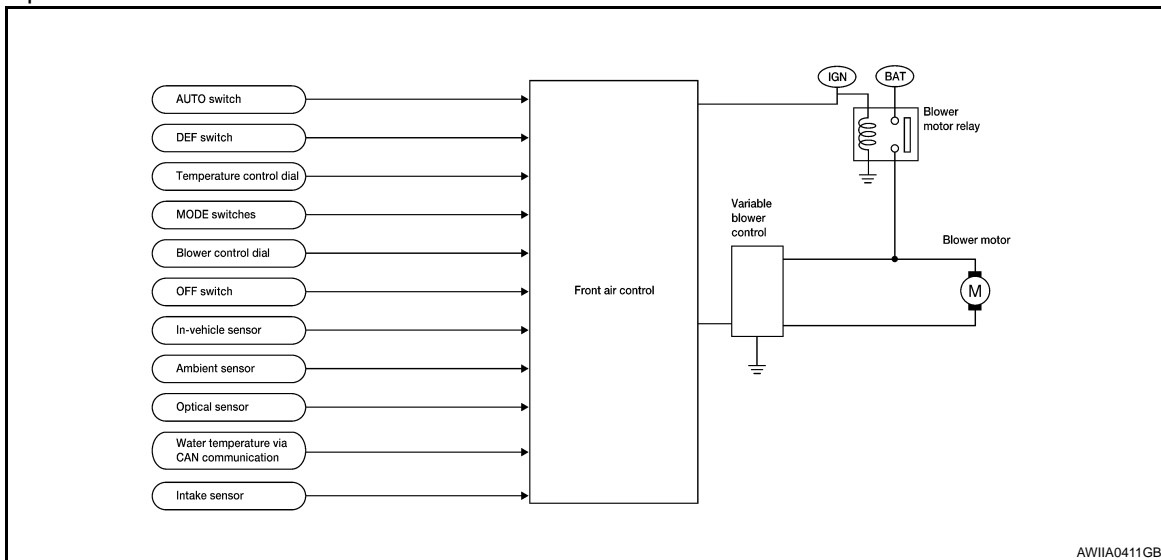

#### Automatic Mode

In the automatic mode, the blower motor speed is calculated by the front air control and variable blower control based on input from the in-vehicle sensor, optical sensor, intake sensor and ambient sensor, and potentiometer temperature control (PTC).

When the air flow is increased, the blower motor speed is adjusted gradually to prevent a sudden increase in air flow.

In addition to manual air flow control and the usual automatic air flow control, starting air flow control, low water temperature starting control and high passenger compartment temperature starting control are available.

#### Starting Blower Speed Control

Start up from cold soak condition (Automatic mode).

In a cold start up condition where the engine coolant temperature is below 50°C (122°F), the blower will not operate at blower speed 1 for a short period of time (up to 210 seconds). The exact start delay time varies depending on the ambient and engine coolant temperatures.

In the most extreme case (very low ambient temperature) the blower starting delay will be 210 seconds as described above. After the coolant temperature reaches 50°C (122°F), or the 210 seconds has elapsed, the blower speed will increase to the objective blower speed.

Start up from usual operating or hot soak condition (Automatic mode).

The blower will begin operation momentarily after the AUTO switch is pushed. The blower speed will gradually rise to the objective speed over a time period of 3 seconds or less (actual time depends on the objective blower speed).

Blower Speed Compensation - Sunload

# BLOWER MOTOR CONTROL SYSTEM

[AUTOMATIC AIR CONDITIONER]

## < COMPONENT DIAGNOSIS >

When the in-vehicle temperature and the set temperature are very close, the blower will be operating at low speed. The speed will vary depending on the sunload. During conditions of low or no sunload, the blower operates at low speed. During high sunload conditions, the front air control causes the blower speed to increase.

### Blower Speed Control Specification

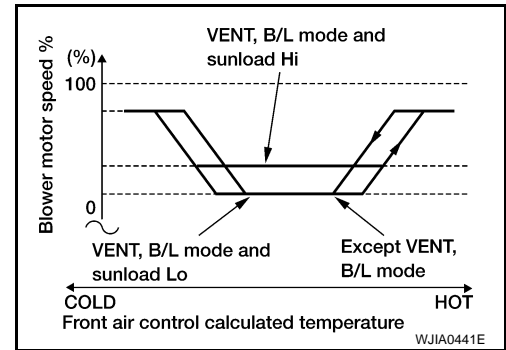

## COMPONENT DESCRIPTION

### Variable Blower Control

The variable blower control is located on the cooling unit. The variable blower control receives a gate voltage from the front air control to steplessly maintain the blower motor voltage in the 0 to 5 volt range (approx.).

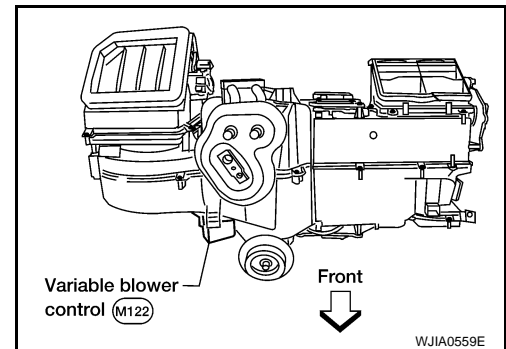

## Front Blower Motor Component Function Check

INFOID:000000001611807

## INSPECTION FLOW

### 1. CONFIRM SYMPTOM BY PERFORMING OPERATIONAL CHECK - FRONT BLOWER

1. Rotate the blower control dial clockwise once. Blower motor should operate in low speed.
2. Rotate the blower control dial clockwise, and continue checking blower speed until all speeds are checked.

#### Can the symptom be duplicated?

- YES >> GO TO 3.
- NO >> GO TO 2.

### 2. CHECK FOR ANY SYMPTOMS

Perform a complete operational check for any symptoms. Refer to [HAC-7, "Operational Check"](#).

#### Does another symptom exist?

- YES >> Refer to [HAC-6, "How to Perform Trouble Diagnosis For Quick And Accurate Repair"](#).
- NO >> System OK.

### 3. CHECK FOR SERVICE BULLETINS

Check for any service bulletins.

>> GO TO 4.

### 4. PERFORM FRONT AIR CONTROL SELF-DIAGNOSIS

Perform self-diagnosis to check for any codes. Refer to [HAC-21, "Front Air Control Self-Diagnosis"](#).

Are any self-diagnosis codes present?

# BLOWER MOTOR CONTROL SYSTEM

[AUTOMATIC AIR CONDITIONER]

## < COMPONENT DIAGNOSIS >

- YES >> Refer to [HAC-21, "Front Air Control Self-Diagnosis Code Chart"](#).  
NO >> GO TO 5.

### 5.CHECK BLOWER MOTOR OPERATION

Check and verify blower motor operates manually in all speeds.

Does blower motor operate in all speeds?

- YES >> GO TO 6.  
NO >> Refer to [HAC-48, "Front Blower Motor Diagnosis Procedure"](#).

### 6.CHECK ENGINE COOLANT TEMPERATURE SENSOR CIRCUIT

Check engine coolant temperature sensor circuit. Refer to [EC-125, "Diagnosis Procedure"](#).

Is the inspection results normal?

- YES >> GO TO 7.  
NO >> Replace enging coolant temperature sensor.

### 7.RECHECK FOR ANY SYMPTOMS

Perform a complete operational check for any symptoms. Refer to [HAC-7, "Operational Check"](#).

Does another symptom exist?

- YES >> Refer to [HAC-6, "How to Perform Trouble Diagnosis For Quick And Accurate Repair"](#) .  
NO >> Replace front air control. Refer to [VTL-8, "Removal and Installation"](#).

## Front Blower Motor Diagnosis Procedure

INFOID:000000001611808

SYMPTOM: Blower motor operation is malfunctioning.

### DIAGNOSTIC PROCEDURE FOR BLOWER MOTOR

SYMPTOM: Blower motor operation is malfunctioning under starting blower speed control.

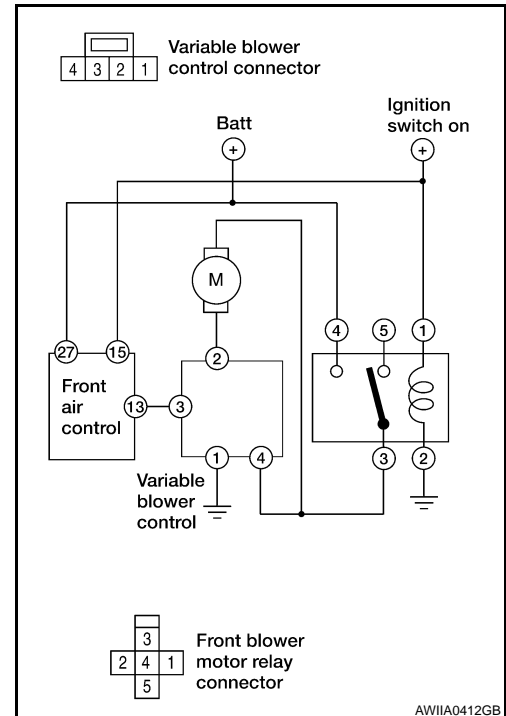

AWIIA0412GB

### 1.CHECK FUSES

Check 20A fuses [No. 24 and 27 (Located in the fuse and fusible link box)]. For fuse layout. Refer to [PG-67, "Terminal Arrangement"](#).

**Fuses are good.**

Is the inspection result normal?

- YES >> GO TO 3.  
NO >> GO TO 9.



# BLOWER MOTOR CONTROL SYSTEM

[AUTOMATIC AIR CONDITIONER]

< COMPONENT DIAGNOSIS >

## 2. CHECK FRONT BLOWER MOTOR POWER SUPPLY CIRCUIT

1. Turn ignition switch OFF.
2. Disconnect front blower motor connector.
3. Turn ignition switch ON.
4. Press the A/C switch.
5. Rotate blower control dial to maximum speed.
6. Check voltage between front blower motor harness connector M62 terminal 2 and ground.

**2 - Ground** : **Battery voltage**

Is the inspection result normal?

- YES >> GO TO 10.  
NO >> GO TO 3.

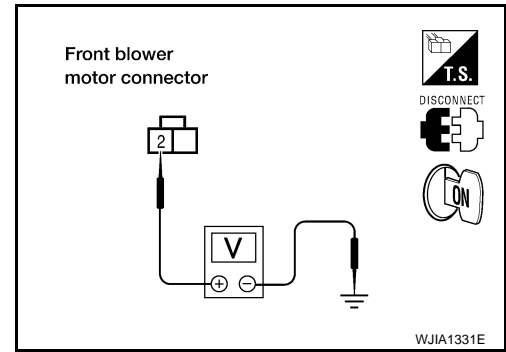

## 3. CHECK FRONT BLOWER MOTOR RELAY (SWITCH SIDE) POWER SUPPLY CIRCUIT

1. Turn ignition switch OFF.
2. Disconnect front blower motor relay.
3. Check voltage between front blower motor relay harness connector M107 terminal 5 and ground.

**5 - Ground** : **Battery voltage**

Is the inspection result normal?

- YES >> GO TO 4.  
NO >> Repair harness or connector.

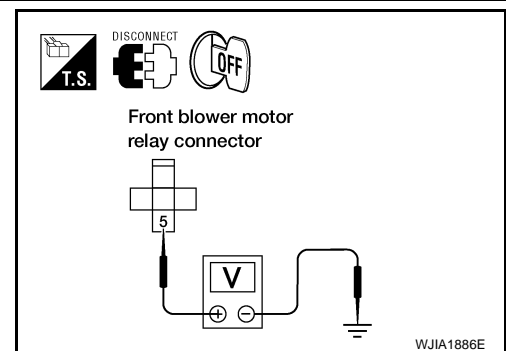

## 4. CHECK FRONT BLOWER MOTOR RELAY

Turn ignition switch OFF.

Check front blower motor relay. Refer to [HAC-51, "Front Blower Motor Component Inspection"](#).

Is the inspection result normal?

- YES >> GO TO 5.  
NO >> Replace front blower motor relay.

## 5. CHECK FRONT BLOWER MOTOR RELAY (SWITCH SIDE) CIRCUIT FOR OPEN

Check continuity between front blower motor relay harness connector M107 terminal 3 and front blower motor harness connector M62 terminal 2.

**3 - 2** : **Continuity should exist.**

Is the inspection result normal?

- YES >> GO TO 6.  
NO >> Repair harness or connector.

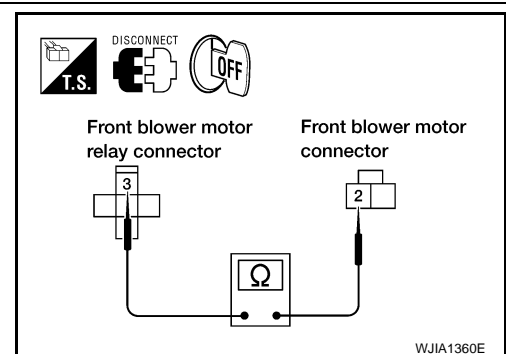

## 6. CHECK VARIABLE BLOWER CONTROL POWER SUPPLY CIRCUIT FOR OPEN

# BLOWER MOTOR CONTROL SYSTEM

[AUTOMATIC AIR CONDITIONER]

## < COMPONENT DIAGNOSIS >

1. Disconnect variable blower control harness connector.
2. Check continuity between front blower motor relay harness connector M107 (A) terminals 3 and variable blower control harness connector M122 (B) terminal 4.

**3 - 4 : Continuity should exist.**

Is the inspection result normal?

- YES >> GO TO 7.  
NO >> Repair harness or connector.

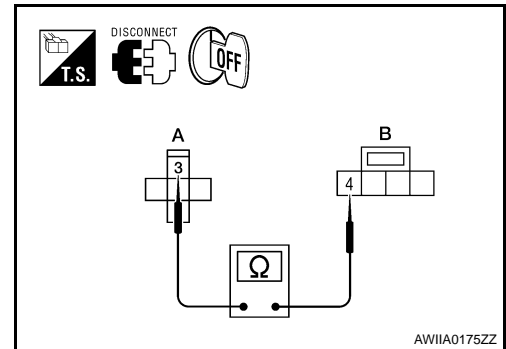

## 7. CHECK VARIABLE BLOWER CONTROL SIGNAL CIRCUIT

1. Disconnect front air control connector.
2. Check continuity between front air control harness connector M49 (B) terminal 13 and variable blower control harness connector M122 (A) terminal 3.

**13 - 3 : Continuity should exist.**

Is the inspection result normal?

- YES >> GO TO 8.  
NO >> Repair harness or connector.

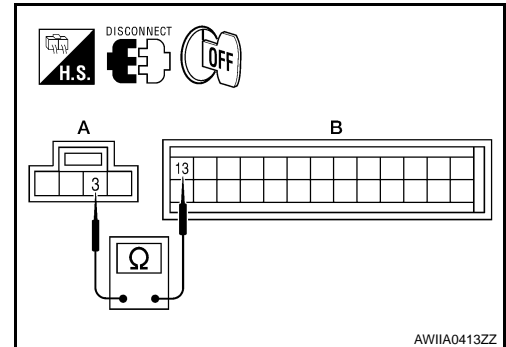

## 8. CHECK FRONT BLOWER MOTOR RELAY (COIL SIDE) POWER SUPPLY

1. Turn ignition switch ON.
2. Check voltage between front blower motor relay harness connector M107 terminal 2 and ground.

**2 - Ground : Battery voltage**

Is the inspection result normal?

- YES >> GO TO 9.  
NO >> Repair front blower motor ground circuit or connector.

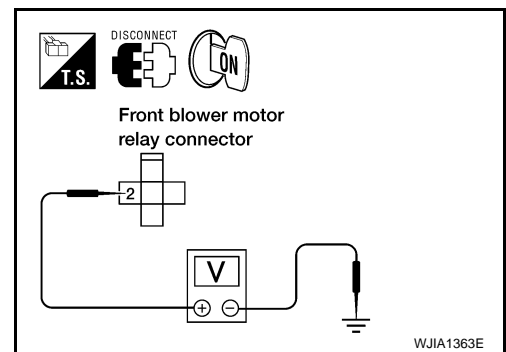

## 9. REPLACE FUSES

1. Replace fuses.
2. Activate the front blower motor.

Does the fuse blow?

- YES >> GO TO 10.  
NO >> Inspection End.

## 10. CHECK FRONT BLOWER MOTOR POWER SUPPLY CIRCUIT FOR SHORT

1. Turn ignition switch OFF.
2. Disconnect front blower motor connector and variable blower control connector.
3. Check continuity between variable blower control harness connector M122 terminal 4 and ground.

**4 - Ground : Continuity should not exist.**

Is the inspection result normal?

- YES >> GO TO 11.  
NO >> Repair harness or connector.

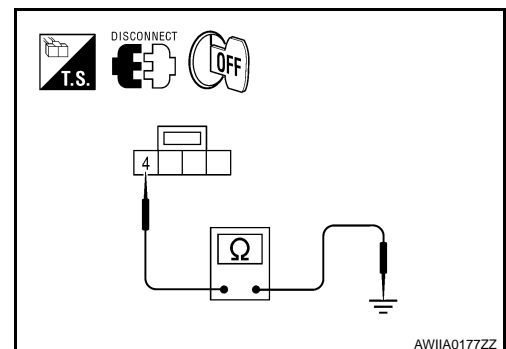

## 11. CHECK VARIABLE BLOWER CONTROL SIGNAL CIRCUIT

# BLOWER MOTOR CONTROL SYSTEM

[AUTOMATIC AIR CONDITIONER]

## < COMPONENT DIAGNOSIS >

1. Disconnect front air control connector.
2. Check continuity between front air control harness connector M49 (B) terminal 13 and variable blower control harness connector M122 (A) terminal 3.

**13 - 3** : Continuity should exist.

Is the inspection result normal?

YES >> GO TO 12.

NO >> Repair harness or connector.

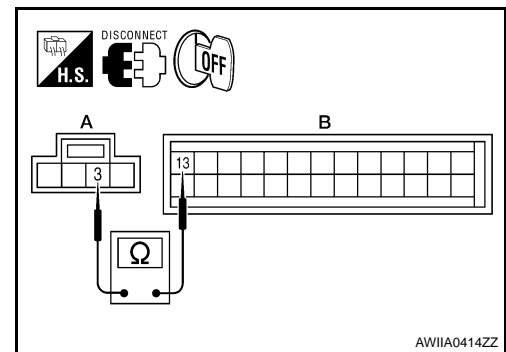

## 12.CHECK FRONT BLOWER MOTOR

Check front blower motor. Refer to [HAC-51, "Front Blower Motor Component Inspection"](#).

Is the inspection result normal?

YES >> GO TO 13.

NO >> Replace front blower motor. Refer to [VTL-12, "Removal and Installation"](#).

## 13.CHECK BLOWER MOTOR GROUND CIRCUIT

Check continuity between front blower motor harness connector M62 terminal 1 and variable blower control harness connector M122 terminal 2.

**1 - 2** : Continuity should exist.

Is the inspection result normal?

YES >> GO TO 14.

NO >> Repair harness or connector.

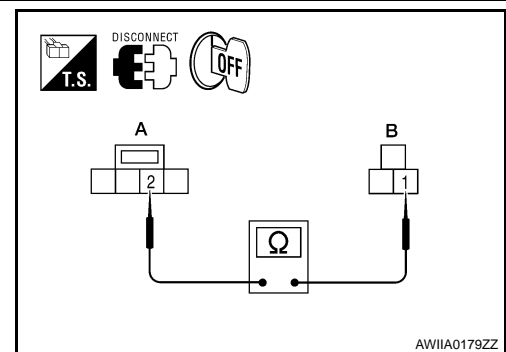

## 14.CHECK VARIABLE BLOWER CONTROL GROUND CIRCUIT

Check continuity between variable blower control harness connector M122 terminal 1 and ground.

**1 - Ground** : Continuity should exist.

Is the inspection result normal?

YES >> Replace variable blower control. Refer to [VTL-22, "Removal and Installation"](#).

NO >> Repair harness or connector.

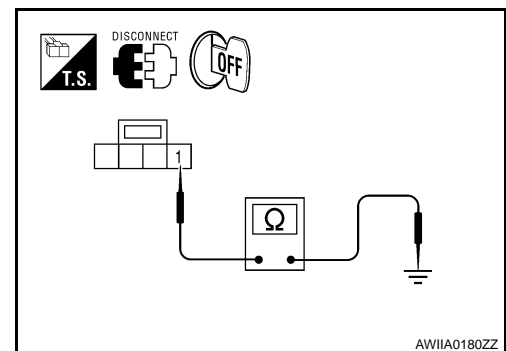

Front Blower Motor Component Inspection

INFOID:000000001611809

COMPONENT INSPECTION

# BLOWER MOTOR CONTROL SYSTEM

[AUTOMATIC AIR CONDITIONER]

## < COMPONENT DIAGNOSIS >

Check continuity between terminals 3, and 5 by supplying 12 volts and ground to coil side terminals 1 and 2 of relay.

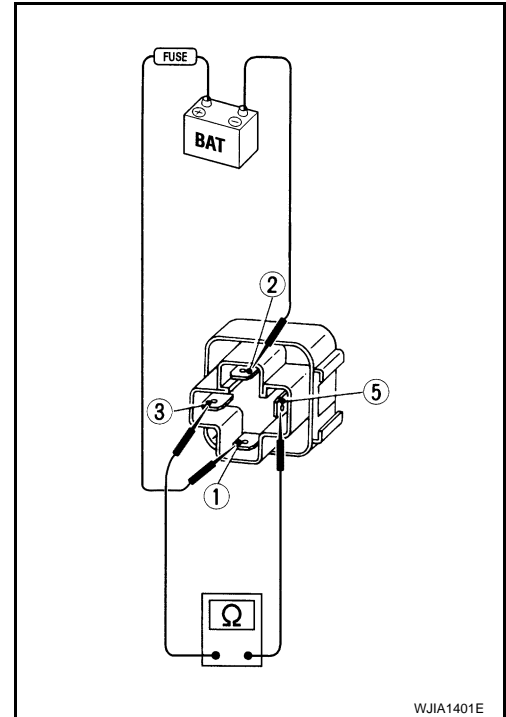

### Front Blower Motor

Confirm smooth rotation of the blower motor.

- Ensure that there are no foreign particles inside the blower unit.
- Apply 12 volts to terminal 2 and ground to terminal 1 and verify that the motor operates freely and quietly.

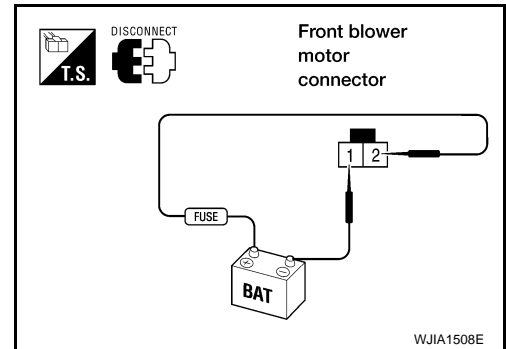

# MAGNET CLUTCH

< COMPONENT DIAGNOSIS >

[AUTOMATIC AIR CONDITIONER]

## MAGNET CLUTCH

### System Description

INFOID:000000001611819

### SYSTEM DESCRIPTION

The front air control controls compressor operation based on ambient and intake temperature and a signal from ECM.

#### Low Temperature Protection Control

The front air control will turn the compressor ON or OFF as determined by a signal detected by the intake sensor and the ambient sensor.

When intake air temperature is higher than the preset value, the compressor turns ON. The compressor turns OFF when intake air temperature is lower than the preset value. That preset value is dependent on the ambient temperature, refer to the following table.

Ambient temperature °C (°F)	Compressor ON intake temperature °C (°F)	Compressor OFF intake temperature °C (°F)
0 (32)	5.5 (42)	5.0 (41)
10 (50)	5.5 (42)	5.0 (41)
20 (68)	5.5 (42)	5.0 (41)
30 (86)	4.0 (39)	3.5 (38)
40 (104)	3.5 (38)	3.0 (37)
50 (122)	3.5 (38)	3.0 (37)

### Magnet Clutch Component Function Check

INFOID:000000001611820

### INSPECTION FLOW

#### 1.CONFIRM SYMPTOM BY PERFORMING OPERATIONAL CHECK - MAGNET CLUTCH

1. Turn ignition switch ON.
2. Press the A/C switch.
3. Press vent mode switch (❏).
4. Confirm that the compressor clutch engages (sound or visual inspection). (Discharge air and blower speed will depend on ambient, in-vehicle and set temperatures.)

#### Can the symptom be duplicated?

- YES >> GO TO 3.  
NO >> GO TO 2.

#### 2.CHECK FOR ANY SYMPTOMS

Perform a complete operational check for any symptoms. Refer to [HAC-7. "Operational Check"](#).

#### Does another symptom exist?

- YES >> Refer to [HAC-6. "How to Perform Trouble Diagnosis For Quick And Accurate Repair"](#).  
NO >> System OK.

#### 3.CHECK FOR SERVICE BULLETINS

Check for any service bulletins.

>> GO TO 4.

#### 4.PERFORM SELF-DIAGNOSIS

Perform self-diagnosis to check for any codes. Refer to [HAC-21. "Front Air Control Self-Diagnosis"](#).

#### Are any self-diagnosis codes present?

- YES >> Refer to [HAC-21. "Front Air Control Self-Diagnosis Code Chart"](#).  
NO >> GO TO 5.

#### 5.CHECK AMBIENT SENSOR

A  
B  
C  
D  
E  
F  
G  
H

HAC

J  
K  
L  
M  
N  
O  
P

# MAGNET CLUTCH

[AUTOMATIC AIR CONDITIONER]

< COMPONENT DIAGNOSIS >

Check and verify ambient sensor circuit. Refer to [HAC-60. "Ambient Sensor Diagnosis Procedure"](#).

>> GO TO 6.

## 6. CHECK INTAKE SENSOR

Check and verify intake sensor circuit. Refer to [HAC-68. "Intake Sensor Diagnosis Procedure"](#).

>> GO TO 7.

## 7. RECHECK FOR ANY SYMPTOMS

Perform a complete operational check for any symptoms. Refer to [HAC-7. "Operational Check"](#).

Does another symptom exist?

YES >> Refer to [HAC-6. "How to Perform Trouble Diagnosis For Quick And Accurate Repair"](#).

NO >> Replace front air control. Refer to [VTL-8. "Removal and Installation"](#).

## Magnet Clutch Diagnosis Procedure

INFOID:000000001611821

### DIAGNOSTIC PROCEDURE FOR MAGNET CLUTCH

SYMPTOM: Magnet clutch does not engage when A/C switch is ON.

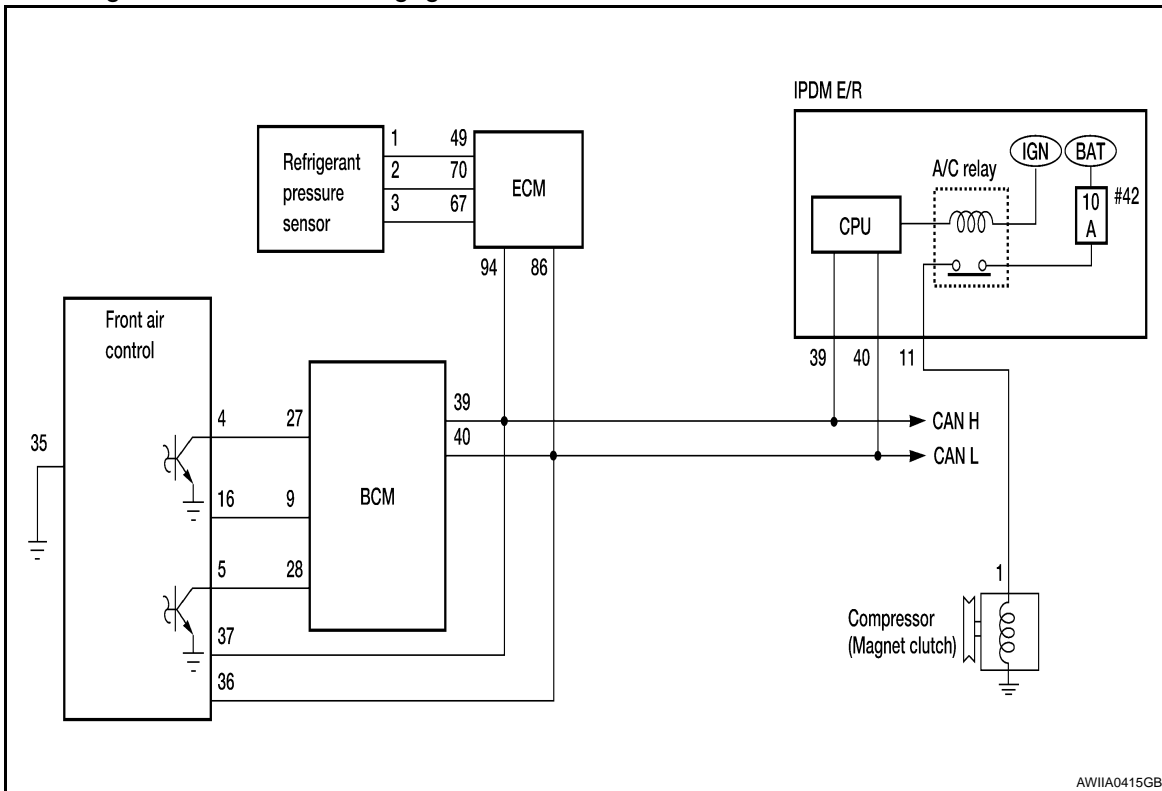

## 1. CHECK INTAKE AND AMBIENT SENSOR CIRCUITS

Check intake and ambient sensors. Refer to [HAC-21. "Front Air Control Self-Diagnosis"](#).

Is the inspection result normal?

YES >> GO TO 2.

NO >> • Malfunctioning intake sensor. Refer to [HAC-68. "Intake Sensor Diagnosis Procedure"](#).

• Malfunctioning ambient sensor. Refer to [HAC-60. "Ambient Sensor Diagnosis Procedure"](#).

## 2. PERFORM AUTO ACTIVE TEST

Refer to XX-XX, IN PG.

Does magnet clutch operate?

YES >> •  WITH CONSULT-III  
GO TO 5.

•  WITHOUT CONSULT-III

# MAGNET CLUTCH

[AUTOMATIC AIR CONDITIONER]

## < COMPONENT DIAGNOSIS >

GO TO 6.

NO >> Check 10A fuse (No. 42, located in IPDM E/R), and GO TO 3.

### 3. CHECK CIRCUIT CONTINUITY BETWEEN IPDM E/R AND COMPRESSOR

1. Turn ignition switch OFF.
2. Disconnect IPDM E/R connector and compressor (magnet clutch) connector.
3. Check continuity between IPDM E/R harness connector E119 terminal 11 and A/C compressor harness connector F3 terminal 1.

**11 - 1 : Continuity should exist.**

Is the inspection result normal?

YES >> GO TO 4.

NO >> Repair harness or connector.

### 4. CHECK MAGNET CLUTCH CIRCUIT

Check for operation sound when applying battery voltage direct current to terminal.

Is the inspection result normal?

YES >> Replace IPDM E/R. Refer to [PCS-30, "Removal and Installation of IPDM E/R"](#).

NO >> Replace magnet clutch. Refer to [HA-34, "Removal and Installation for Compressor Clutch"](#).

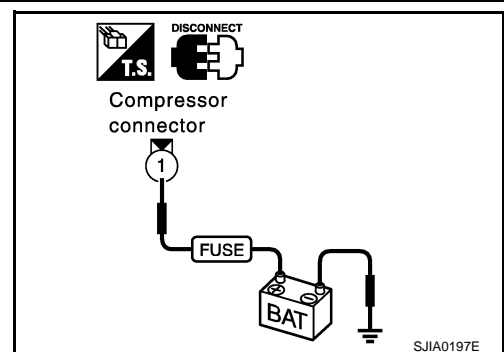
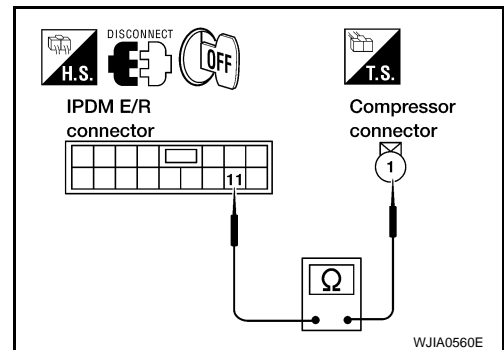

### 5. CHECK BCM INPUT (COMPRESSOR ON) SIGNAL

Check compressor ON/OFF signal. Refer to [HAC-18, "CONSULT-III Function \(HVAC\)"](#).

**A/C SW ON : COMP ON SIG ON**

**A/C SW OFF : COMP ON SIG OFF**

Is the inspection result normal?

YES >> GO TO 8.

NO >> GO TO 6.

### 6. CHECK CIRCUIT CONTINUITY BETWEEN BCM AND FRONT AIR CONTROL

1. Turn ignition switch OFF.
2. Disconnect BCM connector and front air control connector.
3. Check continuity between BCM harness connector M18 (A) terminal 27 and front air control harness connector M49 (B) terminal 4.

**27 - 4 Continuity should exist.**

Is the inspection result normal?

YES >> GO TO 7.

NO >> Repair harness or connector.

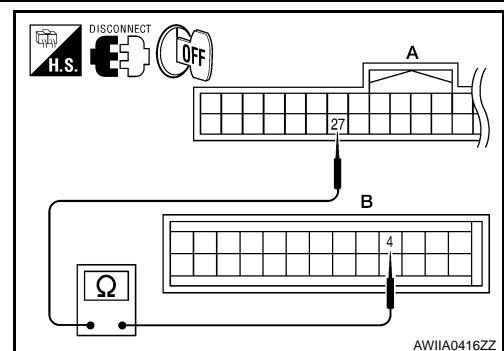

### 7. CHECK VOLTAGE FOR FRONT AIR CONTROL (A/C COMPRESSOR ON SIGNAL)

# MAGNET CLUTCH

[AUTOMATIC AIR CONDITIONER]

## < COMPONENT DIAGNOSIS >

1. Reconnect BCM connector and front air control connector.
2. Turn ignition switch ON.
3. Check voltage between front air control harness connector M49 terminal 4 and ground.

Terminals		(-)	Condition	Voltage
(+) Front air control connector				
Terminal No.				
M49	4	Ground	A/C switch: ON	Approx. 0V
			A/C switch: OFF	Approx. 5V

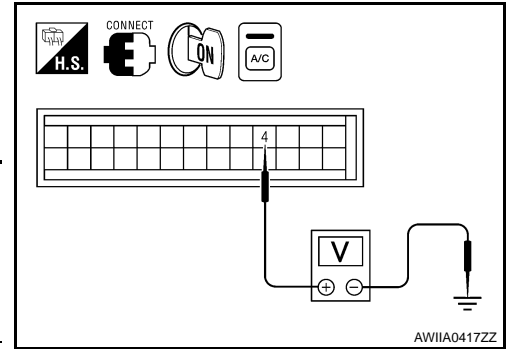

Is the inspection result normal?

YES >> GO TO 8.

NO-1 >> If the voltage is approx. 5V when A/C switch is ON, replace front air control. Refer to [VTL-8, "Removal and Installation"](#).

NO-2 >> If the voltage is approx. 0V when A/C switch is OFF, replace BCM. Refer to [BCS-50, "Removal and Installation"](#).

## 8. CHECK REFRIGERANT PRESSURE SENSOR

1. Start engine.
2. Check voltage between ECM harness connector F54 terminal 70 and ground.

Terminals		(-)	Condition	Voltage
(+) ECM connector				
Terminal No.				
F54	70	Ground	A/C switch: ON	Approx. 0.36 - 3.88V

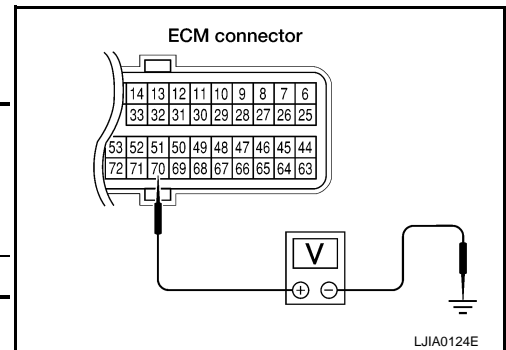

Is the inspection result normal?

YES >> GO TO 9.

NO >> Refer to [EC-412, "Diagnosis Procedure"](#).

## 9. CHECK BCM INPUT (FAN ON) SIGNAL

Check FAN ON/OFF signal. Refer to [HAC-18, "CONSULT-III Function \(HVAC\)"](#).

**FRONT BLOWER CONTROL : FAN ON SIG ON  
DIAL ON**

**FRONT BLOWER CONTROL : FAN ON SIG OFF  
DIAL OFF**

Is the inspection result normal?

YES >> GO TO 12.

NO >> GO TO 10.

## 10. CHECK CIRCUIT CONTINUITY BETWEEN BCM AND FRONT AIR CONTROL



# MAGNET CLUTCH

[AUTOMATIC AIR CONDITIONER]

## < COMPONENT DIAGNOSIS >

1. Turn ignition switch OFF.
2. Disconnect BCM connector and front air control connector.
3. Check continuity between BCM harness connector M18 (A) terminal 28 and front air control harness connector M49 terminal 5.

**28 - 5**

**Continuity should exist.**

Is the inspection result normal?

YES >> GO TO 11.

NO >> Repair harness or connector.

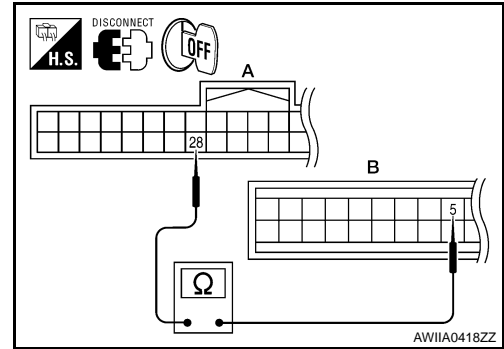

## 11. CHECK VOLTAGE FOR FRONT AIR CONTROL (FAN ON SIGNAL)

1. Reconnect BCM connector and front air control connector.
2. Turn ignition switch ON.
3. Check voltage between front air control harness connector M49 terminal 5 and ground.

Terminals		(-)	Condition	Voltage
(+)	Terminal No.			
Front air control connector				
M49	5	Ground	A/C switch: ON Blower motor operates	Approx. 0V
			A/C switch: OFF	Approx. 5V

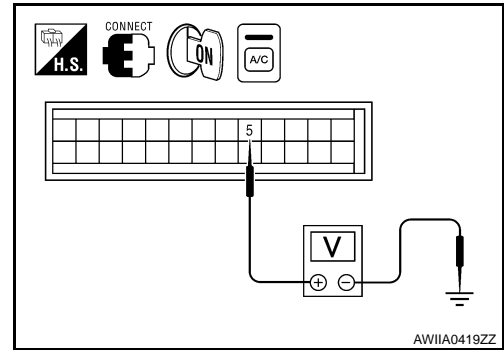

Is the inspection result normal?

YES >> GO TO 12.

NO-1 >> If the voltage is approx. 5V when blower motor is ON, replace front air control. Refer to [VTL-8, "Removal and Installation"](#).

NO-2 >> If the voltage is approx. 0V when blower motor is OFF, replace BCM. Refer to [BCS-50, "Removal and Installation"](#).

## 12. CHECK CAN COMMUNICATION

Check CAN communication. Refer to [LAN-4, "System Description"](#).

- BCM – ECM
- ECM – IPDM E/R
- ECM – Front air control

Is the inspection result normal?

YES >> Inspection End.

NO >> Repair or replace malfunctioning part(s).

# WATER VALVE CIRCUIT

< COMPONENT DIAGNOSIS >

[AUTOMATIC AIR CONDITIONER]

## WATER VALVE CIRCUIT

### Description

INFOID:000000001611822

### COMPONENT DESCRIPTION

#### Water Valve

The water valve (1) cuts the flow of engine coolant to the heater core to allow for maximum cooling during A/C operation. It is controlled by the front air control.

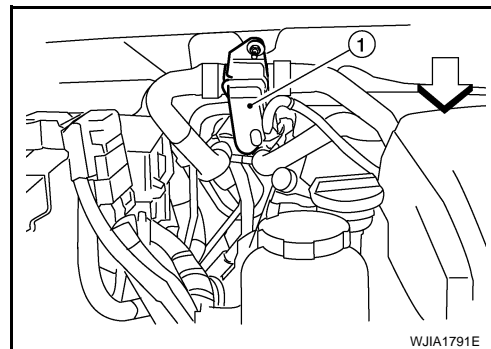

### Water Valve Diagnosis Procedure

INFOID:000000001611823

#### DIAGNOSTIC PROCEDURE FOR WATER VALVE

#### 1. CHECK WATER VALVE POWER AND GROUND CIRCUITS

1. Disconnect water valve connector F68.
2. Turn ignition switch ON.
3. Rotate temperature control dial (driver) to 32°C (90°F).
4. Check voltage between water valve harness connector F68 terminal 1 and terminal 2 while rotating temperature control dial (driver) to 16°C (60°F).

Connector	Terminals		Condition	Voltage (Approx.)
	(+)	(-)		
Water valve: F68	2	1	Rotate temperature control dial	Battery voltage

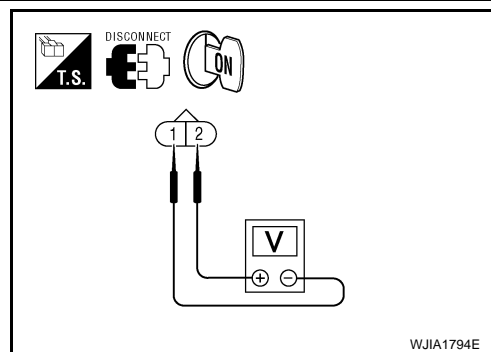

Is the inspection result normal?

- YES >> GO TO 3.  
NO >> GO TO 2.

#### 2. CHECK WATER VALVE CONTROL OUTPUT CIRCUIT

1. Turn ignition switch OFF.
2. Disconnect front air control connector M50.
3. Check continuity between water valve harness connector F68 (A) terminal 2 and front air control harness connector M50 (B) terminal 42.

**2 - 42** : Continuity should exist.

4. Check continuity between water valve harness connector F68 terminal 2 and ground.

**2 - Ground** : Continuity should not exist.

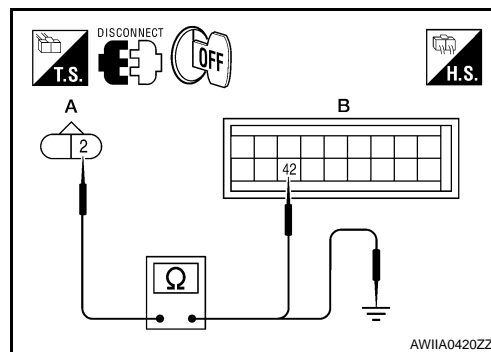

Is the inspection result normal?

- YES >> Replace front air control. Refer to [VTL-8, "Removal and Installation"](#).  
NO >> Repair harness or connector.

#### 3. CHECK WATER VALVE POWER AND GROUND CIRCUITS

# WATER VALVE CIRCUIT

[AUTOMATIC AIR CONDITIONER]

## < COMPONENT DIAGNOSIS >

1. Rotate temperature control dial (driver) to 16°C (60°F).
2. Check voltage between water valve harness connector F68 terminal 1 and terminal 2 while rotating temperature control dial (driver) to 32°C (90°F).

Connector	Terminals		Condition	Voltage (Approx.)
	(+)	(-)		
Water valve: F68	1	2	Rotate temperature control dial	Battery voltage

**Is the inspection result normal?**

- YES >> Replace the water valve.  
 NO >> GO TO 4.

## 4. CHECK WATER VALVE CONTROL OUTPUT CIRCUIT

1. Turn ignition switch OFF.
2. Disconnect front air control connector M50.
3. Check continuity between water valve harness connector F68 (A) terminal 1 and front air control harness connector M50 (B) terminal 41.

**1 - 41 : Continuity should exist.**

4. Check continuity between water valve harness connector F68 (A) terminal 1 and ground.

**1 - Ground : Continuity should not exist.**

**Is the inspection result normal?**

- YES >> Replace front air control. Refer to [VTL-8, "Removal and Installation"](#).  
 NO >> Repair harness or connector.

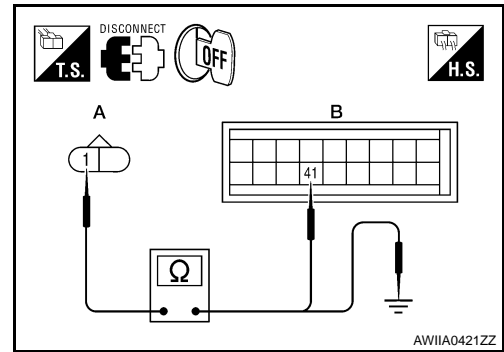
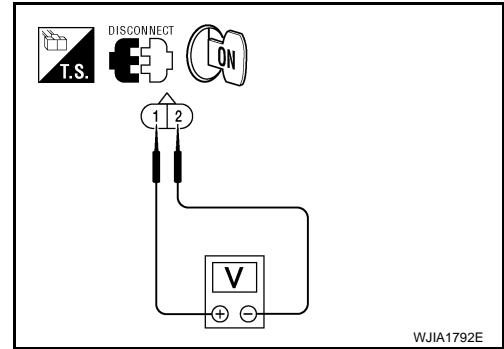

A  
B  
C  
D  
E  
F  
G  
H  
J  
K  
L  
M  
N  
O  
P

HAC

## AMBIENT SENSOR

### Component Description

INFOID:000000001611824

#### COMPONENT DESCRIPTION

##### Ambient Sensor

The ambient sensor is attached on the radiator core support (left side). It detects ambient temperature and converts it into a value which is then input into the front air control.

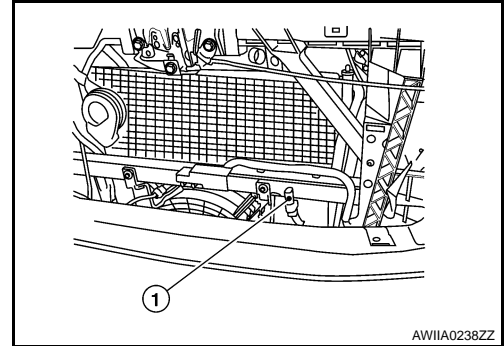

#### AMBIENT TEMPERATURE INPUT PROCESS

The front air control includes a processing circuit for the ambient sensor input. However, when the temperature detected by the ambient sensor increases quickly, the processing circuit retards the front air control function. It only allows the front air control to recognize an ambient temperature increase of 0.33°C (0.6°F) per 100 seconds.

This prevents constant adjustments due to momentary conditions, such as stopping after high speed driving. Although the actual ambient temperature has not changed, the temperature detected by the ambient sensor will increase. This is because the heat from the engine compartment can radiate to the front grille area, location of the ambient sensor.

### Ambient Sensor Diagnosis Procedure

INFOID:000000001611825

#### DIAGNOSTIC PROCEDURE FOR AMBIENT SENSOR

**SYMPTOM:** Ambient sensor circuit is open or shorted. Using the Consult-III, DTC B257B or B257C is displayed. Without Consult-III, code 40 or 41 is indicated on front air control as a result of conducting the front air control self-diagnosis.

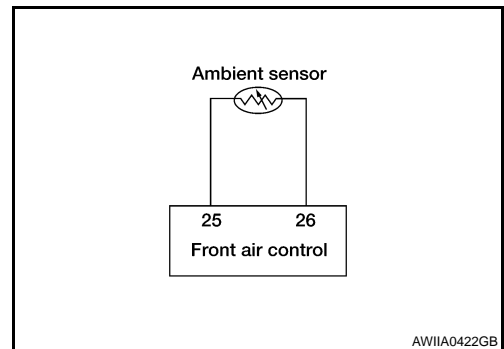

### 1. CHECK VOLTAGE BETWEEN AMBIENT SENSOR AND GROUND

1. Disconnect ambient sensor connector.
2. Turn ignition switch ON.
3. Check voltage between ambient sensor harness connector E1 terminal 1 and ground.

**1 - Ground : Approx. 5V**

Is the inspection result normal?

- YES >> GO TO 3.  
 NO >> GO TO 5.

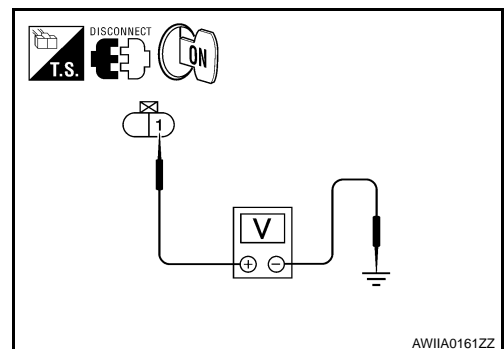

### 2. CHECK CIRCUIT CONTINUITY BETWEEN AMBIENT SENSOR AND FRONT AIR CONTROL

# AMBIENT SENSOR

[AUTOMATIC AIR CONDITIONER]

## < COMPONENT DIAGNOSIS >

1. Turn ignition switch OFF.
2. Disconnect front air control connector.
3. Check continuity between ambient sensor harness connector E1 (B) terminal 1 and front air control harness connector M49 (A) terminal 25.

**1 - 25 : Continuity should exist.**

Is the inspection result normal?

- YES >> GO TO 4.  
NO >> Repair harness or connector.

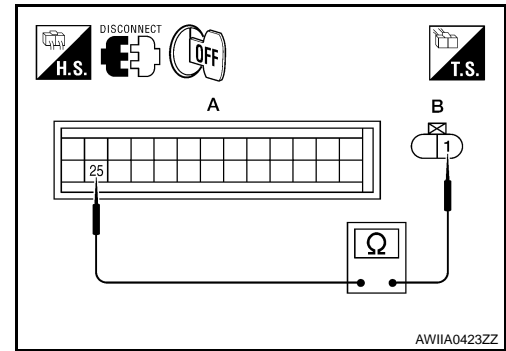

## 3.CHECK AMBIENT SENSOR

Check the Ambient Sensor Circuit. Refer to [HAC-61, "Ambient Sensor Component Inspection"](#).

Is the inspection result normal?

- YES >> 1. Replace front air control. Refer to [VTL-8, "Removal and Installation"](#).  
2. GO TO [HAC-21, "Front Air Control Self-Diagnosis"](#) and perform self-diagnosis.  
NO >> 1. Replace ambient sensor.  
2. GO TO [HAC-21, "Front Air Control Self-Diagnosis"](#) and perform self-diagnosis.

## 4.CHECK CIRCUIT CONTINUITY BETWEEN AMBIENT SENSOR AND FRONT AIR CONTROL

1. Turn ignition switch OFF.
2. Disconnect front air control connector.
3. Check continuity between ambient sensor harness connector E1 (B) terminal 2 and front air control harness connector M49 (A) terminal 26.

**2 - 26 : Continuity should exist.**

4. Check continuity between ambient sensor harness connector E1 (B) terminal 2 and ground.

**2 - Ground : Continuity should not exist.**

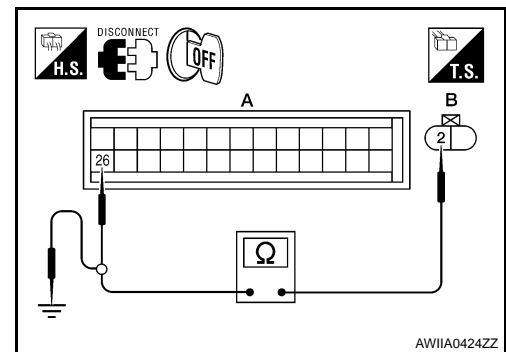

Is the inspection result normal?

- YES >> 1. Replace front air control. Refer to [VTL-8, "Removal and Installation"](#).  
2. GO TO [HAC-21, "Front Air Control Self-Diagnosis"](#) and perform self-diagnosis.  
NO >> Repair harness or connector.

## Ambient Sensor Component Inspection

INFOID:000000001611826

## COMPONENT INSPECTION

Ambient Sensor

# AMBIENT SENSOR

## < COMPONENT DIAGNOSIS >

[AUTOMATIC AIR CONDITIONER]

After disconnecting ambient sensor (1) connector E1, measure resistance between terminals 1 and 2 at sensor component side, using the table below.

Temperature °C (°F)	Resistance kΩ
-15 (5)	12.73
-10 (14)	9.92
-5 (23)	7.80
0 (32)	6.19
5 (41)	4.95
10 (50)	3.99
15 (59)	3.24
20 (68)	2.65
25 (77)	2.19
30 (86)	1.81
35 (95)	1.51
40 (104)	1.27
45 (113)	1.07

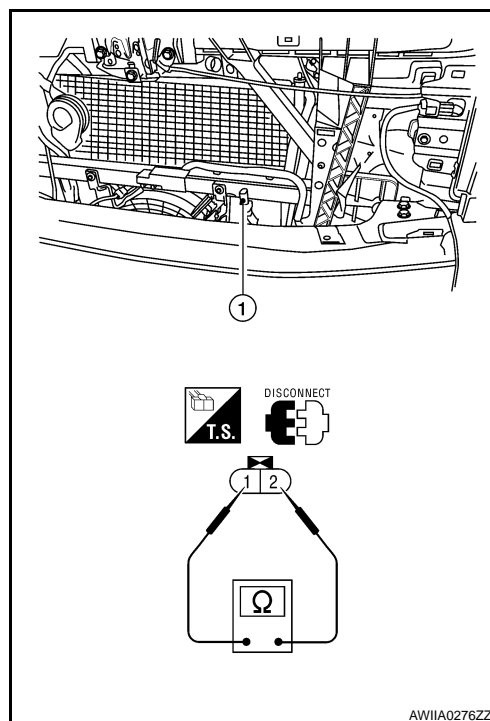

AW1IA0276ZZ

If NG, replace ambient sensor. Refer to [HA-45. "Removal and Installation"](#)

< COMPONENT DIAGNOSIS >

IN-VEHICLE SENSOR

Component Description

INFOID:000000001611827

COMPONENT DESCRIPTION

In-vehicle Sensor

The in-vehicle sensor (1) is located on the lower instrument panel LH. It converts variations in temperature of passenger compartment air (drawn in through the integrated fan) into a resistance value. It is then input into the front air control.

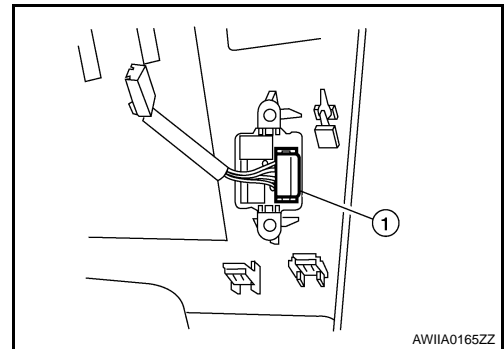
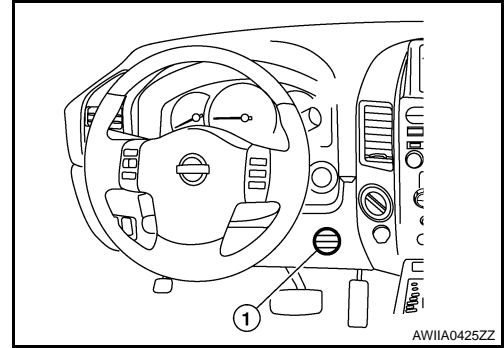

In-Vehicle Sensor Diagnosis Procedure

INFOID:000000001611828

DIAGNOSTIC PROCEDURE FOR IN-VEHICLE SENSOR

SYMPTOM: In-vehicle sensor circuit is open or shorted. Using the CONSULT-III, DTC B2578 or B2579 is displayed. Without a CONSULT-III, code 30, 31 is indicated on front air control as a result of conducting self-diagnosis.

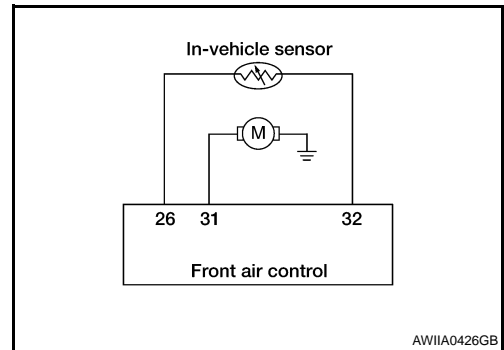

1. CHECK IN-VEHICLE SENSOR CIRCUIT

Is self-diagnosis DTC B2578 or B2579 (with CONSULT-III) or code 30, 31 (without CONSULT-III) present?

YES or NO Is the inspection result normal?

YES >> GO TO 7.

NO >> GO TO 3.

2. CHECK VOLTAGE BETWEEN IN-VEHICLE SENSOR AND GROUND

A  
B  
C  
D  
E  
F  
G  
H  
HAC  
J  
K  
L  
M  
N  
O  
P

# IN-VEHICLE SENSOR

[AUTOMATIC AIR CONDITIONER]

## < COMPONENT DIAGNOSIS >

1. Disconnect in-vehicle sensor connector.
2. Turn ignition switch ON.
3. Check voltage between in-vehicle sensor harness connector M32 terminal 4 and ground.

**4 - Ground** : **Approx. 5V.**

Is the inspection result normal?

- YES >> GO TO 4.  
NO >> GO TO 6.

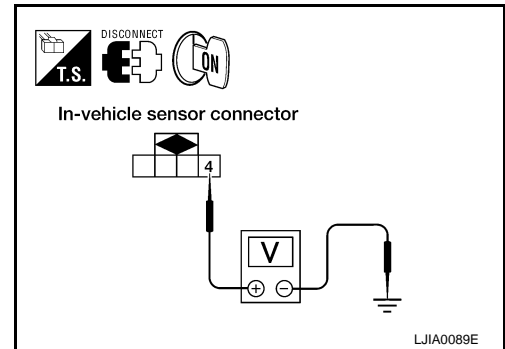

## 3. CHECK CIRCUIT CONTINUITY BETWEEN IN-VEHICLE SENSOR AND FRONT AIR CONTROL

1. Turn ignition switch OFF.
2. Disconnect front air control connector M49.
3. Check continuity between in-vehicle sensor harness connector M32 (B) terminal 1 and front air control harness connector M49 (A) terminal 26.

**1 - 26** : **Continuity should exist.**

Is the inspection result normal?

- YES >> GO TO 5.  
NO >> Repair harness or connector.

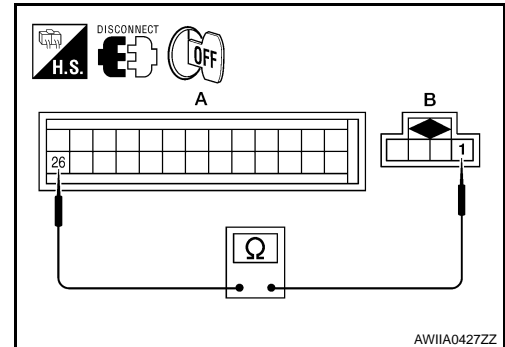

## 4. CHECK IN-VEHICLE SENSOR

Check in-vehicle sensor. Refer to [HAC-65, "In-Vehicle Sensor Component Inspection"](#).

Is the inspection result normal?

- YES >> 1. Replace front air control. Refer to [VTL-8, "Removal and Installation"](#).  
2. Go to [HAC-21, "Front Air Control Self-Diagnosis"](#) and perform self-diagnosis.  
NO >> 1. Replace in-vehicle sensor. Refer to [VTL-9, "Removal and Installation"](#).  
2. Go to [HAC-21, "Front Air Control Self-Diagnosis"](#) and perform self-diagnosis.

## 5. CHECK CIRCUIT CONTINUITY BETWEEN IN-VEHICLE SENSOR AND FRONT AIR CONTROL

1. Turn ignition switch OFF.
2. Disconnect front air control connector.
3. Check continuity between in-vehicle sensor harness connector M32 (B) terminal 4 and front air control harness connector M50 (A) terminal 32.

**4 - 32** : **Continuity should exist.**

4. Check continuity between in-vehicle sensor harness connector M32 (B) terminal 4 and ground.

**4 - Ground** : **Continuity should not exist.**

Is the inspection result normal?

- YES >> 1. Replace front air control. Refer to [VTL-8, "Removal and Installation"](#).  
2. Go to [HAC-21, "Front Air Control Self-Diagnosis"](#) and perform self-diagnosis.  
NO >> Repair harness or connector.

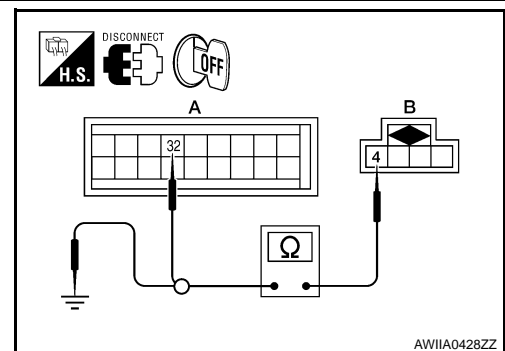

## 6. CHECK CIRCUIT CONTINUITY BETWEEN IN-VEHICLE SENSOR MOTOR AND FRONT AIR CONTROL (SELF-DIAGNOSIS CODES 30, 31, 44, 46 OR DTC B2578, B2579)



# IN-VEHICLE SENSOR

## [AUTOMATIC AIR CONDITIONER]

### < COMPONENT DIAGNOSIS >

1. Turn ignition switch OFF.
2. Disconnect front air control connector and in-vehicle sensor connector.
3. Check continuity between in-vehicle sensor harness connector M32 (B) terminal 3 and front air control harness connector M50 (A) terminal 31.

**3 - 31 : Continuity should exist.**

4. Check continuity between in-vehicle sensor harness connector M32 (B) terminal 3 and ground.

**2 - Ground : Continuity should exist.**

**3 - Ground : Continuity should not exist.**

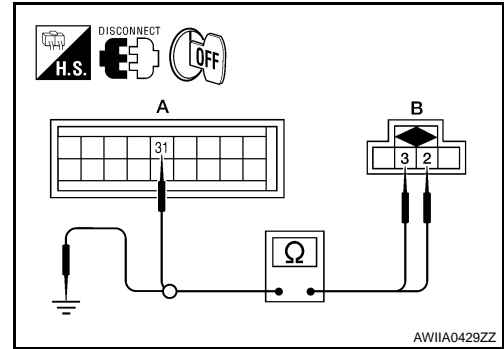

### Is the inspection result normal?

- YES >> 1. Replace front air control. Refer to [VTL-8, "Removal and Installation"](#).  
 2. Go to [HAC-21, "Front Air Control Self-Diagnosis"](#) and perform self-diagnosis.
- NO >> Repair harness or connector.

## In-Vehicle Sensor Component Inspection

INFOID:000000001611829

### COMPONENT INSPECTION

#### In-vehicle Sensor

After disconnecting in-vehicle sensor connector M32, measure resistance between terminals 1 and 4 at sensor component side, using the table below.

Temperature °C (°F)	Resistance kΩ
-15 (5)	21.40
-10 (14)	16.15
-5 (23)	12.29
0 (32)	9.41
5 (41)	7.27
10 (50)	5.66
15 (59)	4.45
20 (68)	3.51
25 (77)	2.79
30 (86)	2.24
35 (95)	1.80
40 (104)	1.45
45 (113)	1.18

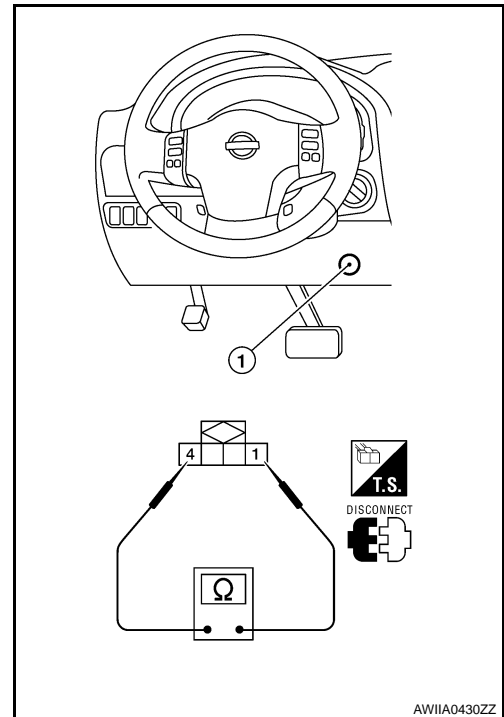

If NG, replace in-vehicle sensor. Refer to [VTL-9, "Removal and Installation"](#)

## OPTICAL SENSOR

### Component Description

INFOID:000000001611830

### COMPONENT DESCRIPTION

The optical sensor is located in the center of the defroster grille. It detects sunload entering through windshield by means of a photo diode. The sensor converts the sunload into a current value which is then input into the front air control.

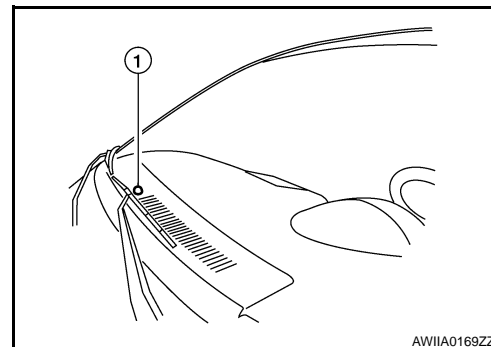

### OPTICAL INPUT PROCESS

The front air control includes a processing circuit which averages the variations in detected sunload over a period of time. This prevents adjustments in the ATC system operation due to small or quick variations in detected sunload.

For example, consider driving along a road bordered by an occasional group of large trees. The sunload detected by the optical sensor will vary whenever the trees obstruct the sunlight. The processing circuit averages the detected sunload over a period of time, so that the (insignificant) effect of the trees momentarily obstructing the sunlight does not cause any change in the ATC system operation. On the other hand, shortly after entering a long tunnel, the system will recognize the change in sunload, and the system will react accordingly.

### Optical Sensor Diagnosis Procedure

INFOID:000000001611831

### DIAGNOSTIC PROCEDURE FOR OPTICAL SENSOR

**SYMPTOM:** Optical sensor circuit is open or shorted. Using the CONSULT-III, DTC B257F or B2580 is displayed. Without a CONSULT-III, code 50 or 52 is indicated on front air control as a result of conducting self-diagnosis.

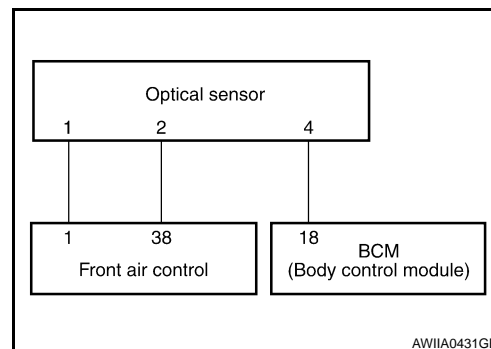

## 1. CHECK CIRCUIT CONTINUITY BETWEEN OPTICAL SENSOR AND FRONT AIR CONTROL

1. Turn ignition switch OFF.
2. Disconnect front air control connector and optical sensor connector.
3. Check continuity between optical sensor harness connector M302 (B) terminals 1 and 2 and front air control harness connector M50 (C) terminal 42 and M49 (A) terminal 1.

**1 - 1 : Continuity should exist.**

**2 - 38 : Continuity should exist.**

4. Check continuity between optical sensor harness connector M302 terminal 1 and 2 and ground.

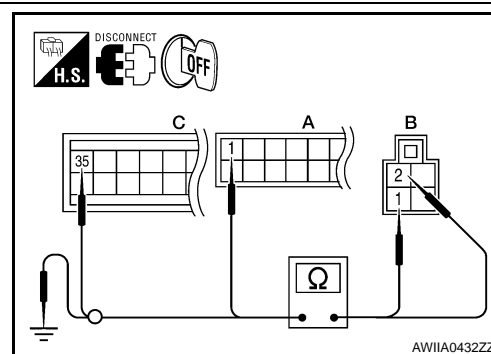

# OPTICAL SENSOR

< COMPONENT DIAGNOSIS >

[AUTOMATIC AIR CONDITIONER]

**1, 2 - Ground. : Continuity should not exist.**

Is the inspection result normal?

YES >> GO TO 2.

NO >> Repair harness or connector.

## 2. CHECK CIRCUIT CONTINUITY BETWEEN OPTICAL SENSOR AND BCM

1. Disconnect BCM connector.
2. Check continuity between optical sensor harness connector M302 (B) terminal 4 and BCM harness connector M18 (A) terminal 18.

**4 - 18 : Continuity should exist.**

3. Check continuity between optical sensor harness connector M302 (A) terminal 4 and ground.

**4 - Ground : Continuity should not exist.**

Is the inspection result normal?

YES >> Replace optical sensor. Refer to [VTL-10. "Removal and Installation"](#).

NO >> Repair harness or connector.

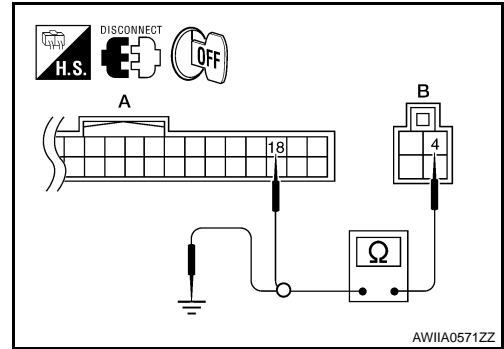

A  
B  
C  
D  
E  
F  
G  
H  
J  
K  
L  
M  
N  
O  
P

HAC

# INTAKE SENSOR

< COMPONENT DIAGNOSIS >

[AUTOMATIC AIR CONDITIONER]

## INTAKE SENSOR

### System Description

INFOID:000000001611832

### COMPONENT DESCRIPTION

#### Intake Sensor

The intake sensor is located on the heater & cooling unit assembly. It converts temperature of air after it passes through the evaporator into a resistance value which is then input to the front air control.

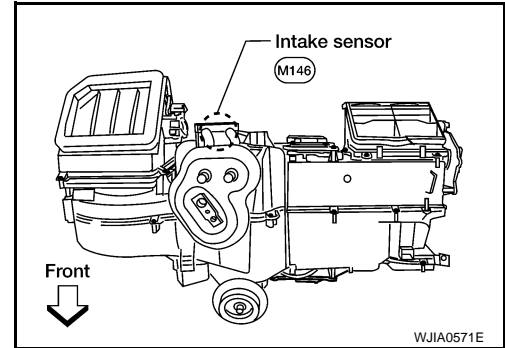

### Intake Sensor Diagnosis Procedure

INFOID:000000001611833

#### DIAGNOSTIC PROCEDURE FOR INTAKE SENSOR

SYMPTOM: Intake sensor circuit is open or shorted. Using the CONSULT-III, DTC B2581 or B2582 is displayed. Without a CONSULT-III, code 56 or 57 is indicated on front air control as a result of conducting self-diagnosis.

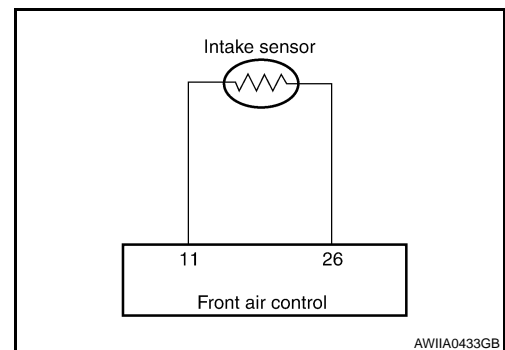

#### 1. CHECK VOLTAGE BETWEEN INTAKE SENSOR AND GROUND

1. Disconnect intake sensor connector.
2. Turn ignition switch ON.
3. Check voltage between intake sensor harness connector M146 terminal 2 and ground.

**2 - Ground : Approx. 5V**

Is the inspection result normal?

- YES >> GO TO 3.  
NO >> GO TO 4.

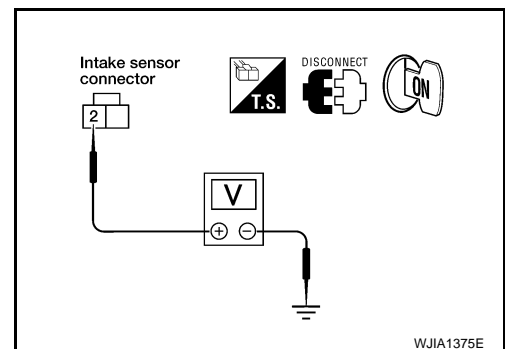

#### 2. CHECK CIRCUIT CONTINUITY BETWEEN INTAKE SENSOR AND FRONT AIR CONTROL

1. Turn ignition switch OFF.
2. Disconnect front air control connector.
3. Check continuity between intake sensor harness connector M146 (B) terminal 1 and front air control harness connector M49 (A) terminal 26.

**1 - 26 : Continuity should exist.**

Is the inspection result normal?

- YES >> GO TO 4.  
NO >> Repair harness or connector.

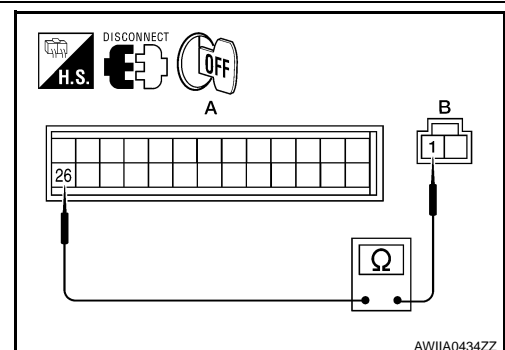

# INTAKE SENSOR

< COMPONENT DIAGNOSIS >

[AUTOMATIC AIR CONDITIONER]

## 3. CHECK INTAKE SENSOR

Check intake sensor. Refer to [HAC-69. "Intake Sensor Component Inspection"](#).

Is the inspection result normal?

- YES >> 1. Replace front air control. Refer to [VTL-8. "Removal and Installation"](#).  
 2. Go to [HAC-21. "Front Air Control Self-Diagnosis"](#) and perform self-diagnosis.
- NO >> 1. Replace intake sensor. Refer to [VTL-11. "Removal and Installation"](#).  
 2. Go to [HAC-21. "Front Air Control Self-Diagnosis"](#) and perform self-diagnosis.

## 4. CHECK CIRCUIT CONTINUITY BETWEEN INTAKE SENSOR AND FRONT AIR CONTROL

- Turn ignition switch OFF.
- Disconnect front air control connector.
- Check continuity between intake sensor harness connector M146 (B) terminal 6 and front air control harness connector M49 (A) terminal 21.

**6 - 21** : Continuity should exist.

- Check continuity between intake sensor harness connector M146 terminal 6 and ground.

**6 - Ground** : Continuity should not exist.

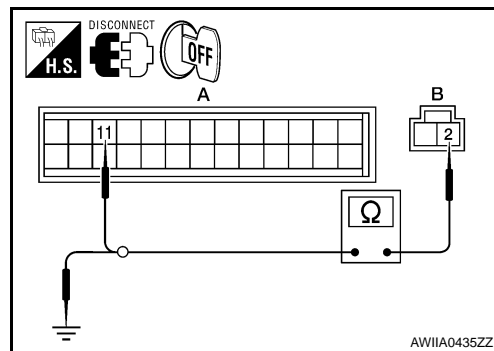

Is the inspection result normal?

- YES >> 1. Replace front air control. Refer to [VTL-8. "Removal and Installation"](#).  
 2. Go to [HAC-21. "Front Air Control Self-Diagnosis"](#) and perform self-diagnosis.
- NO >> Repair harness or connector.

## Intake Sensor Component Inspection

INFOID:000000001611834

HAC

### COMPONENT INSPECTION

Intake Sensor

After disconnecting intake sensor connector, measure resistance between terminals 1 and 2 at sensor harness side, using the table below.

Temperature °C (°F)	Resistance kΩ
-15 (5)	209.0
-10 (14)	160.0
-5 (23)	123.0
0 (32)	95.8
5 (41)	74.9
10 (50)	58.9
15 (59)	46.7
20 (68)	37.3
25 (77)	30.0
30 (86)	24.2
35 (95)	19.7
40 (104)	16.1
45 (113)	13.2

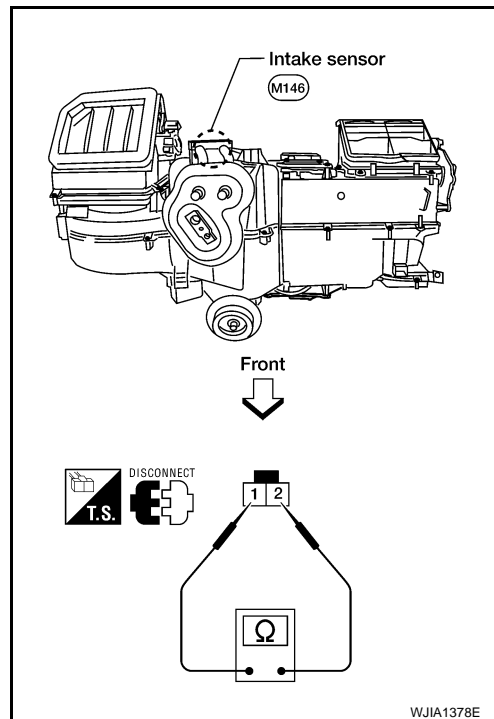

If NG, replace intake sensor. Refer to [VTL-11. "Removal and Installation"](#).

# POWER SUPPLY AND GROUND CIRCUIT FOR CONTROLLER

< COMPONENT DIAGNOSIS >

[AUTOMATIC AIR CONDITIONER]

## POWER SUPPLY AND GROUND CIRCUIT FOR CONTROLLER

### Component Description

INFOID:000000001611835

#### COMPONENT DESCRIPTION

##### Front Air Control

The front air control has a built-in microcomputer which processes information sent from various sensors needed for air conditioner operation. The air mix door motors, mode door motor, intake door motor, defroster door motor, blower motor and compressor are then controlled.

The front air control is unitized with control mechanisms. When the various switches and temperature dials are operated, data is input to the front air control.

Self-diagnostic functions are also built into the front air control to provide quick check of malfunctions in the auto air conditioner system.

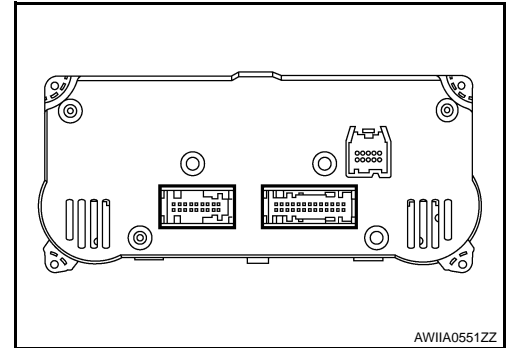

##### Potential Temperature Control (PTC)

There are two PTCs (driver and passenger) built into the front air control. They can be set at an interval of 0.5°C (1.0°F) in the 18°C (60°F) to 32°C (90°F) temperature range by rotating the temperature dial. The set temperature is displayed.

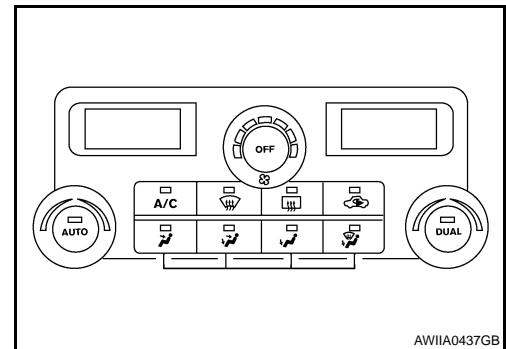

### Front Air Control Component Function Check

INFOID:000000001611836

SYMPTOM: A/C system does not come on.

#### INSPECTION FLOW

#### 1. CONFIRM SYMPTOM BY PERFORMING OPERATIONAL CHECK - AUTO MODE

1. Press AUTO switch.
2. Confirm that the compressor clutch engages (sound or visual inspection). (Discharge air and blower speed will depend on ambient, in-vehicle and set temperatures.)

##### Can a symptom be duplicated?

- YES >> GO TO 3.  
NO >> GO TO 2.

#### 2. PERFORM COMPLETE OPERATIONAL CHECK

Perform a complete operational check and check for any symptoms. Refer to [HAC-7, "Operational Check"](#).

##### Can a symptom be duplicated?

- YES >> Refer to [HAC-6, "How to Perform Trouble Diagnosis For Quick And Accurate Repair"](#).  
NO >> System OK.

#### 3. CHECK FOR SERVICE BULLETINS

Check for any service bulletins.

>> GO TO 4.

#### 4. CHECK POWER AND GROUND CIRCUIT

Check main power supply and ground circuit. Refer to [HAC-71, "Front Air Control Power and Ground Diagnosis Procedure"](#).

# POWER SUPPLY AND GROUND CIRCUIT FOR CONTROLLER

[AUTOMATIC AIR CONDITIONER]

< COMPONENT DIAGNOSIS >

Is the inspection result normal?

YES >> System OK.

NO >> Replace front air control. Refer to [VTL-8. "Removal and Installation"](#).

## Front Air Control Power and Ground Diagnosis Procedure

INFOID:000000001611837

### DIAGNOSTIC PROCEDURE FOR A/C SYSTEM

SYMPTOM: A/C system does not come on.

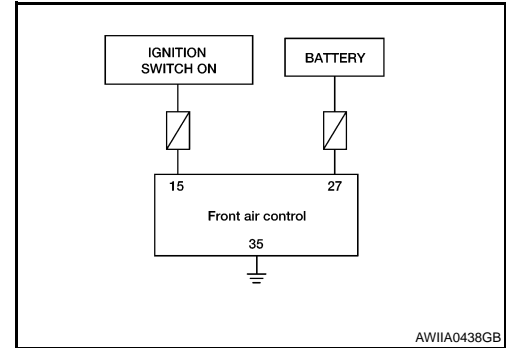

## 1. CHECK POWER SUPPLY CIRCUITS FOR FRONT AIR CONTROL

1. Disconnect front air control connectors.
2. Check voltage between front air control harness connector M49 (B) terminal 15 and M50 (A) terminal 27, and ground.

Terminals		Ignition switch position			
(+)		(-)	OFF	ACC	ON
front air control connector	Terminal No.				
M49	15	Ground	Approx. 0V	Approx. 0V	Battery voltage
M50	27		Battery voltage	Battery voltage	Battery voltage

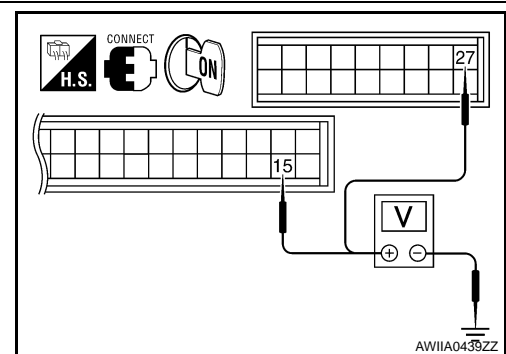

Is the inspection result normal?

YES >> GO TO 3.

NO >> Check 10A fuses [Nos. 8 and 19, located in the fuse block (J/B)]. Refer to [PG-67. "Terminal Arrangement"](#).

- If fuses are OK, check harness for open circuit. Repair or replace as necessary.
- If fuses are NG, replace fuse and check harness for short circuit. Repair or replace as necessary.

## 2. CHECK GROUND CIRCUIT FOR FRONT AIR CONTROL

1. Turn ignition switch OFF.
2. Check continuity between front air control harness connector M50 terminal 35 and ground.

**35 - Ground : Continuity should exist.**

Is the inspection result normal?

OK >> Replace front air control. Refer to [VTL-8. "Removal and Installation"](#).

NG >> Repair harness or connector.

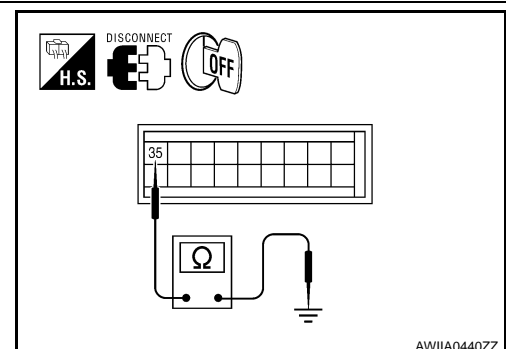

# AIR CONDITIONER CONTROL

[AUTOMATIC AIR CONDITIONER]

< ECU DIAGNOSIS >

## ECU DIAGNOSIS

### AIR CONDITIONER CONTROL

#### Front Air Control Terminals Reference Values

INFOID:000000001611838

Measure voltage between each terminal and ground by following Terminals and Reference Value for front air control (1).

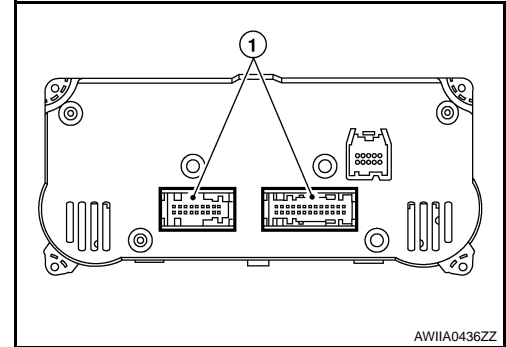

AWIIA0436ZZ

#### FRONT AIR CONTROL HARNESS CONNECTOR TERMINAL LAYOUT

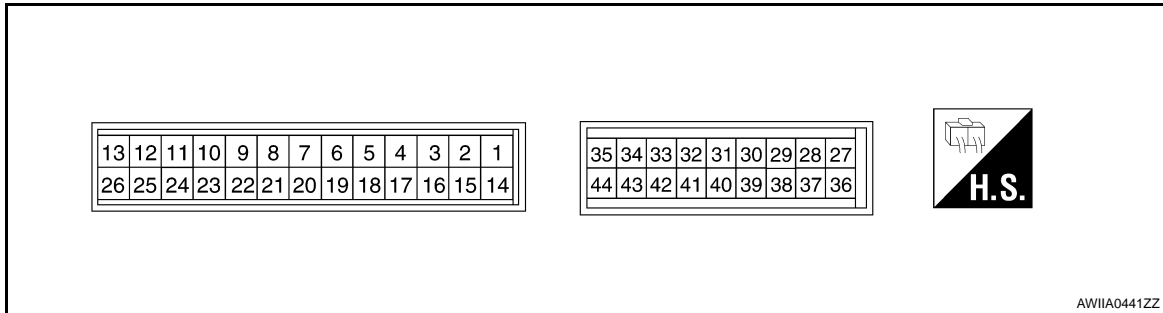

AWIIA0441ZZ

#### TERMINALS AND RERERENCE VALUES FOR FRONT AIR CONTROL

Terminal No.	Wire color	Item	Ignition switch	Condition	Voltage (V) (Approx.)
1	G/O	Optical sensor (driver)	ON	-	0 - 5V
2	L	Air mix door motor (passenger) CCW	ON	-	Battery voltage
3	P	V ref ACTR (ground)	ON	-	5V
4	W/R	Compressor ON signal	ON	A/C switch OFF	5V
			ON	A/C switch ON	0V
5	L/R	Fan ON signal	ON	Blower switch OFF	5V
			ON	Blower switch ON	0V
6	SB	Air mix door motor (driver) feedback	ON	-	0 - 5V
7	GR	Mode door motor feedback	ON	-	0 - 5V
8	R/L	Illumination +	ON	Park lamps ON	Battery voltage
9	BR	Illumination -	-	Park lamps ON	<p>(V)</p> <p>15</p> <p>10</p> <p>5</p> <p>0</p> <p>200 ms</p>
10	LG/B	Defroster door motor feedback	ON	-	0 - 5V
11	L/B	Intake sensor	ON	-	0 - 5V
13	G/R	Variable blower control	ON	-	0 - 5V
14	G/W	Air mix door motor (passenger) CW	ON	Clockwise rotation	Battery voltage

PIIA2344E



# AIR CONDITIONER CONTROL

< ECU DIAGNOSIS >

[AUTOMATIC AIR CONDITIONER]

Terminal No.	Wire color	Item	Ignition switch	Condition	Voltage (V) (Approx.)	
15	Y/G	Power supply for IGN	ON	-	Battery voltage	A
16	Y/B	Rear Defroster Request *1	ON		Battery voltage	B
17	W/G	Air mix door motor (driver) CW	ON	Clockwise rotation	Battery voltage	B
18	G	Air mix door motor (driver) CCW	ON	Counterclockwise rotation	Battery voltage	
19	BR/W	Mode door motor CW	ON	Clockwise rotation	Battery voltage	C
20	P/L	Mode door motor CCW	ON	Counterclockwise rotation	Battery voltage	
21	G/B	Intake door motor CCW	ON	Counterclockwise rotation	Battery voltage	
22	O	Intake door motor CW	ON	Clockwise rotation	Battery voltage	D
23	LG	Defroster door motor CW	ON	Clockwise rotation	Battery voltage	
24	P/B	Defroster door motor CCW	ON	Counterclockwise rotation	Battery voltage	E
25	P	Ambient sensor	ON	-	0 - 5V	
26	V/R	Sensor ground	ON	-	0V	
27	Y/R	Power supply for BAT	-	-	Battery voltage	F
28	Y	V ref ACTR (5V)	ON	-	0 - 5V	
29	R/W	Air mix door motor (passenger) feedback	ON	-	0 - 5V	G
31	BR/Y	In-vehicle sensor motor (+)	ON	-	Battery voltage	
32	LG/R	In-vehicle sensor signal	ON	-	0 - 5V	H
35	B	Ground	-	-	0V	
36	P	CAN-L	ON	-	0 - 5V	
37	L	CAN-H	ON	-	0 - 5V	HAC
38	W/V	Optical sensor (passenger)	ON	-	0 - 5V	
41	Y/L	Water valve	ON	Water valve open	Battery voltage	J
				Water valve closed	0V	
42	W/G	Water valve	ON	Water valve open	0V	
				Water valve closed	Battery voltage	K

\*1: If equipped

# AIR CONDITIONER CONTROL

[AUTOMATIC AIR CONDITIONER]

< ECU DIAGNOSIS >

## Wiring Diagram

INFOID:000000001611839

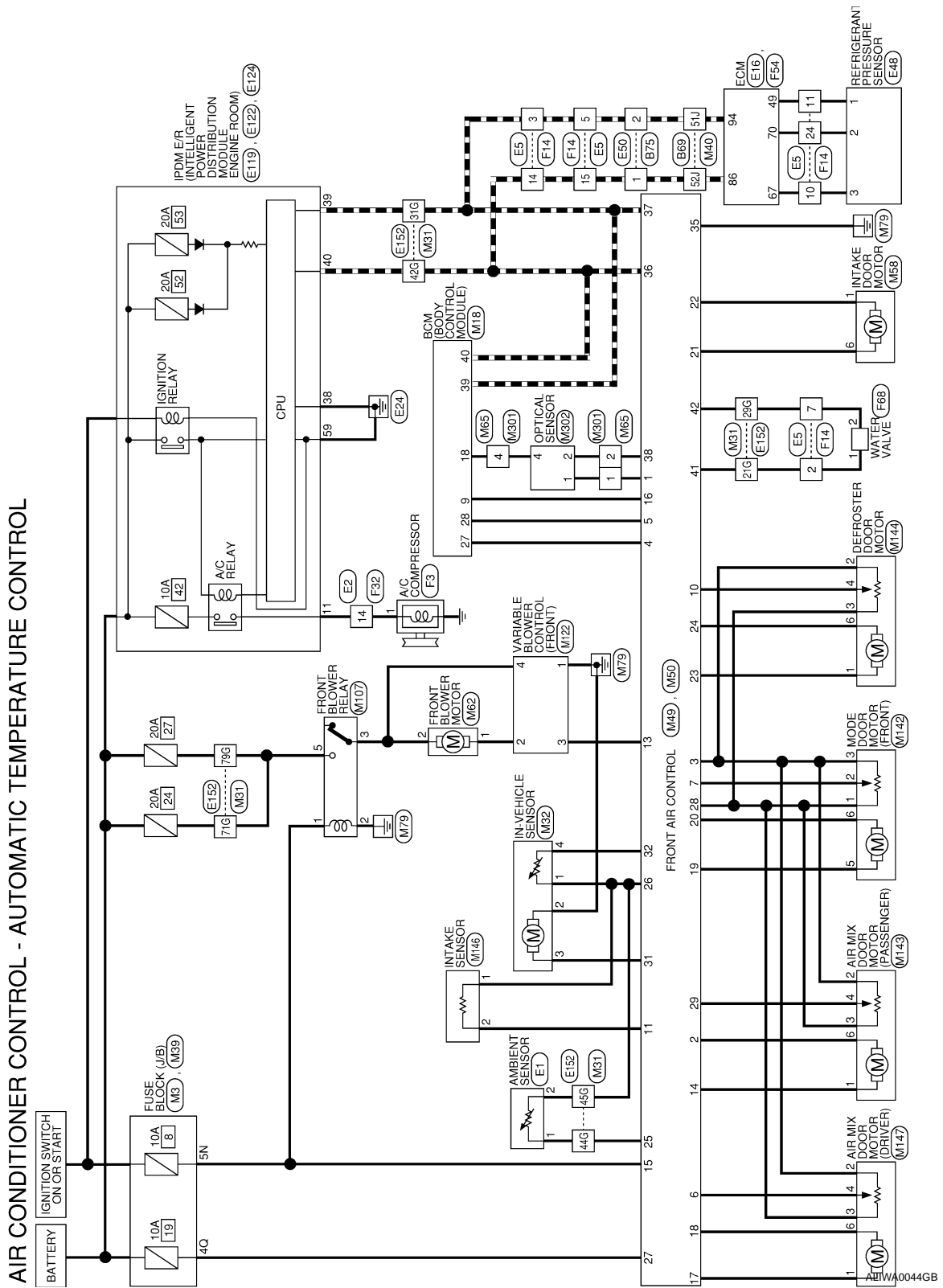

### AIR CONDITIONER CONTROL - AUTOMATIC TEMPERATURE CONTROL CONNECTORS

Connector No.	M3
Connector Name	FUSE BLOCK (J/B)
Connector Color	WHITE

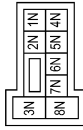

Terminal No.	Color of Wire	Signal Name
5N	Y/G	-

Connector No.	M18
Connector Name	BCM (BODY CONTROL MODULE)
Connector Color	WHITE

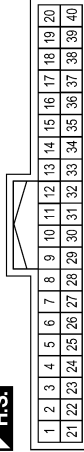

Terminal No.	Color of Wire	Signal Name
9	Y/B	RR DEF SW
18	P	KEYLESS GND
27	W/R	AIR CON SW
28	L/R	BLR_FAN_SW
39	L	CAN-H
40	P	CAN-L

Connector No.	M31
Connector Name	WIRE TO WIRE
Connector Color	WHITE

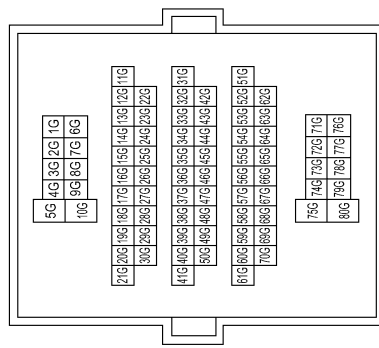

Terminal No.	Color of Wire	Signal Name
21G	Y/L	-
29G	W/G	-
31G	L	-
42G	P	-
44G	P	-
45G	V/R	-
71G	P	-
79G	P	-

Connector No.	M32
Connector Name	IN-VEHICLE SENSOR
Connector Color	WHITE

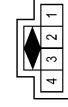

Terminal No.	Color of Wire	Signal Name
1	V/R	-
2	O/B	-
3	BR/Y	-
4	LG/R	-

ALIIA0176GB

# AIR CONDITIONER CONTROL

[AUTOMATIC AIR CONDITIONER]

< ECU DIAGNOSIS >

Terminal No.	Color of Wire	Signal Name
51J	L	-
52J	P	-

Connector No.	M40
Connector Name	WIRE TO WIRE
Connector Color	WHITE

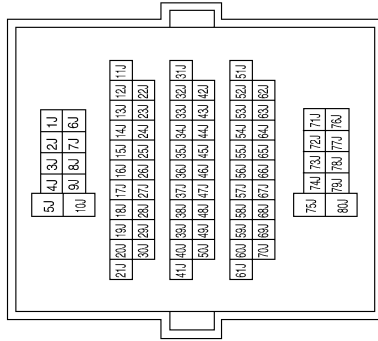

Connector No.	M39
Connector Name	FUSE BLOCK (J/B)
Connector Color	WHITE

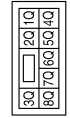

Terminal No.	Color of Wire	Signal Name
4Q	Y/R	-

Connector No.	M49
Connector Name	A/C AUTO AMP.
Connector Color	BLACK

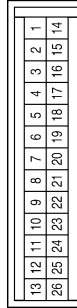

Terminal No.	Color of Wire	Signal Name
1	G/O	SUNLOAD SEN LEFT (DR)
2	L	PASS BLEND DR B
3	P	V REF RETURN (GND)
4	W/R	AC REQUEST
5	L/R	FAN ON
6	SB	DOOR BLEND DOOR FEEDBACK
7	GR	FLOOR FEEDBACK

Terminal No.	Color of Wire	Signal Name
10	LG/B	PANEL DEFROST FEEDBACK
11	L/B	EVAP AIR TEMP SENS
13	G/R	UBL SIGNAL PWR
14	GW	PASS BLEND DR A
15	Y/G	IGN
16	Y/B	RR DEF REQUEST
17	W/G	DR BLEND DOOR A
18	G	DR BLEND DOOR B
19	BR/W	FLOOR A
20	P/L	FLOOR B
21	G/B	RECIRC DOOR A
22	O	RECIRC DOOR B
23	LG	PANEL DEFROST A
24	P/B	PANEL DEFROST B
25	P	AMB TEMP SENS
26	V/R	SENS RETURN

ALI1A0177GB

# AIR CONDITIONER CONTROL

[AUTOMATIC AIR CONDITIONER]

< ECU DIAGNOSIS >

Connector No.	M58
Connector Name	INTAKE DOOR MOTOR
Connector Color	BLACK

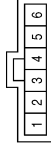

Terminal No.	Color of Wire	Signal Name
1	O	-
6	G/B	-

Terminal No.	Color of Wire	Signal Name
27	Y/R	B
28	Y	V REF ACTR (5V)
29	R/W	PASS BLEND DR FEEDBACK
31	BR/Y	IN CAR MTR+
32	LG/R	IN CAR TEMP SENS
35	B	GND
36	P	CAN-L
37	L	CAN-H
38	W/V	SUNLOAD SEN RIGHT (DR)
41	Y/L	WATER VALVE CLOSE
42	W/G	WATER VALVE OPEN

Connector No.	M50
Connector Name	A/C AUTO AMP.
Connector Color	BLUE

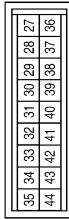

Connector No.	M107
Connector Name	FRONT BLOWER RELAY
Connector Color	BLACK

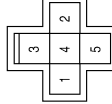

Terminal No.	Color of Wire	Signal Name
1	Y/G	-
2	B	-
3	W/L	-
5	GR	-

Connector No.	M65
Connector Name	WIRE TO WIRE
Connector Color	WHITE



Terminal No.	Color of Wire	Signal Name
1	G/O	-
2	W/V	-
4	P	-

Connector No.	M62
Connector Name	FRONT BLOWER MOTOR
Connector Color	BLACK



Terminal No.	Color of Wire	Signal Name
1	L/W	-
2	W/L	-

A  
B  
C  
D  
E  
F  
G  
H  
HAC  
J  
K  
L  
M  
N  
O  
P

# AIR CONDITIONER CONTROL

[AUTOMATIC AIR CONDITIONER]

< ECU DIAGNOSIS >

Connector No.	M122
Connector Name	VARIABLE BLOWER CONTROL (FRONT)
Connector Color	WHITE



Terminal No.	Color of Wire	Signal Name
1	B/W	-
2	L/W	-
3	G/R	-
4	W/L	-

Connector No.	M142
Connector Name	MODE DOOR MOTOR (FRONT)
Connector Color	BLACK

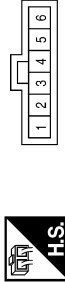

Terminal No.	Color of Wire	Signal Name
1	Y	-
2	GR	-
3	P	-
5	BR/W	-
6	P/L	-

Connector No.	M143
Connector Name	AIR MIX DOOR MOTOR (PASSENGER)
Connector Color	BLACK



Terminal No.	Color of Wire	Signal Name
1	G/W	-
2	P	-
3	Y	-
4	R/W	-
6	L	-

Connector No.	M144
Connector Name	DEFROSTER DOOR MOTOR
Connector Color	BLACK



Terminal No.	Color of Wire	Signal Name
1	LG	-
2	P	-
3	Y	-
4	LG/B	-
6	P/B	-

Connector No.	M146
Connector Name	INTAKE SENSOR
Connector Color	GRAY



Terminal No.	Color of Wire	Signal Name
1	V/R	-
2	L/B	-

Connector No.	M147
Connector Name	AIR MIX DOOR MOTOR (DRIVER)
Connector Color	BLACK



Terminal No.	Color of Wire	Signal Name
1	W/G	-
2	P	-
3	Y	-
4	SB	-
6	G	-

ALIIA0179GB

# AIR CONDITIONER CONTROL

[AUTOMATIC AIR CONDITIONER]

< ECU DIAGNOSIS >

Connector No.	E1
Connector Name	AMBIENT SENSOR
Connector Color	GRAY

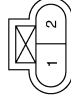

Terminal No.	Color of Wire	Signal Name
1	P	-
2	V/R	-

Connector No.	M302
Connector Name	OPTICAL SENSOR
Connector Color	WHITE



Terminal No.	Color of Wire	Signal Name
1	G/O	-
2	W/V	-
4	P	-

Connector No.	M301
Connector Name	WIRE TO WIRE
Connector Color	WHITE

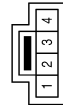

Terminal No.	Color of Wire	Signal Name
1	G/O	-
2	W/V	-
4	P	-

Connector No.	E16
Connector Name	ECM
Connector Color	BLACK

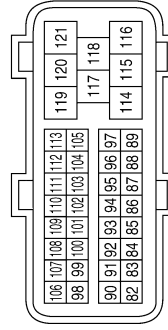

Terminal No.	Color of Wire	Signal Name
86	P	CAN-L
94	L	CAN-H

Connector No.	E5
Connector Name	WIRE TO WIRE
Connector Color	WHITE

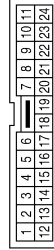

Terminal No.	Color of Wire	Signal Name
2	Y/L	-
3	L	-
5	L	-
7	W/G	-
14	P	-
15	P	-

Connector No.	E2
Connector Name	WIRE TO WIRE
Connector Color	WHITE

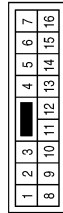

Terminal No.	Color of Wire	Signal Name
14	Y/B	-

ALIIA0180GB

A  
B  
C  
D  
E  
F  
G  
H  
HAC  
J  
K  
L  
M  
N  
O  
P

# AIR CONDITIONER CONTROL

[AUTOMATIC AIR CONDITIONER]

< ECU DIAGNOSIS >

Connector No.	E122
Connector Name	IPDM E/R (INTELLIGENT POWER DISTRIBUTION MODULE ENGINE ROOM)
Connector Color	WHITE

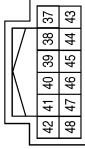

Terminal No.	Color of Wire	Signal Name
38	B	GND (SIG)
39	L	CAN-H
40	P	CAN-L

Connector No.	E119
Connector Name	IPDM E/R (INTELLIGENT POWER DISTRIBUTION MODULE ENGINE ROOM)
Connector Color	WHITE

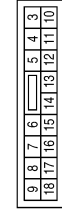

Terminal No.	Color of Wire	Signal Name
11	Y/B	AC_COMP

Connector No.	E50
Connector Name	WIRE TO WIRE
Connector Color	BROWN



Terminal No.	Color of Wire	Signal Name
1	P	-
2	L	-

Terminal No.	Color of Wire	Signal Name
21G	Y/L	-
29G	W/G	-
31G	L	-
42G	P	-
44G	P	-
45G	V/R	-
71G	P	-
79G	GR	-

Connector No.	E152
Connector Name	WIRE TO WIRE
Connector Color	WHITE

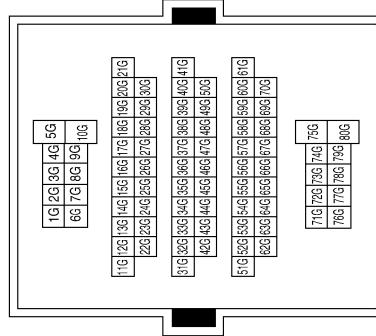

Connector No.	E124
Connector Name	IPDM E/R (INTELLIGENT POWER DISTRIBUTION MODULE ENGINE ROOM)
Connector Color	BLACK



Terminal No.	Color of Wire	Signal Name
59	B	GND (PWR)

ALIIA0181GB



# AIR CONDITIONER CONTROL

[AUTOMATIC AIR CONDITIONER]

< ECU DIAGNOSIS >

Connector No.	F3
Connector Name	A/C COMPRESSOR
Connector Color	BLACK



Terminal No.	Color of Wire	Signal Name
1	Y/B	-

Connector No.	F14
Connector Name	WIRE TO WIRE
Connector Color	WHITE

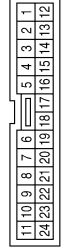

Terminal No.	Color of Wire	Signal Name
2	Y/L	-
3	L	-
5	L	-
7	W/G	-
14	P	-
15	P	-

Connector No.	F32
Connector Name	WIRE TO WIRE
Connector Color	WHITE

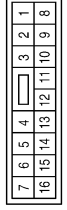

Terminal No.	Color of Wire	Signal Name
14	Y/B	-

Connector No.	F68
Connector Name	WATER VALVE
Connector Color	GRAY



Terminal No.	Color of Wire	Signal Name
1	Y/L	-
2	W/G	-

Connector No.	B69
Connector Name	WIRE TO WIRE
Connector Color	WHITE

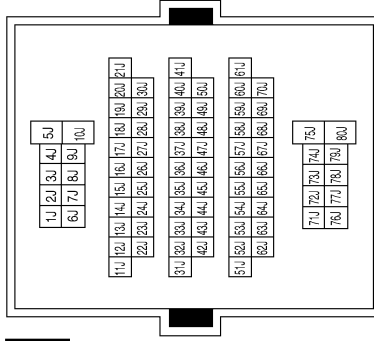

Terminal No.	Color of Wire	Signal Name
51J	L	-
52J	P	-

ALIIA0182GB

A  
B  
C  
D  
E  
F  
G  
H  
HAC  
J  
K  
L  
M  
N  
O  
P

# AIR CONDITIONER CONTROL

< ECU DIAGNOSIS >

[AUTOMATIC AIR CONDITIONER]

Connector No.	B75
Connector Name	WIRE TO WIRE
Connector Color	BROWN



Terminal No.	Color of Wire	Signal Name
1	P	-
2	L	-

ALIIA0183GB

# AIR CONDITIONER CONTROL

[AUTOMATIC AIR CONDITIONER]

< SYMPTOM DIAGNOSIS >

## SYMPTOM DIAGNOSIS

### AIR CONDITIONER CONTROL

#### Symptom Matrix Chart

INFOID:000000001611840

#### SYMPTOM TABLE

Symptom	Reference Page	
A/C system does not come on.	Go to Trouble Diagnosis Procedure for A/C System.	<a href="#">HAC-70</a>
A/C system cannot be controlled.	Go to Self-diagnosis Function.	<a href="#">HAC-21</a>
Air outlet does not change.	Go to Trouble Diagnosis Procedure for Mode Door Motor.	<a href="#">HAC-23</a>
Mode door motor is malfunctioning.		
Discharge air temperature does not change.	Go to Trouble Diagnosis Procedure for Air Mix Door Motor.	<a href="#">HAC-29</a>
Air mix door motor is malfunctioning.		
Intake door does not change.	Go to Trouble Diagnosis Procedure for Intake Door Motor.	<a href="#">HAC-38</a>
Intake door motor is malfunctioning.		
Defroster door motor is malfunctioning.	Go to Trouble Diagnosis Procedure for Defroster Door Motor.	<a href="#">HAC-41</a>
Front blower motor operation is malfunctioning.	Go to Trouble Diagnosis Procedure for Front Blower Motor.	<a href="#">HAC-47</a>
Magnet clutch does not engage.	Go to Trouble Diagnosis Procedure for Magnet Clutch.	<a href="#">HAC-53</a>
Insufficient cooling	Go to Trouble Diagnosis Procedure for Insufficient Cooling.	<a href="#">HAC-84</a>
Insufficient heating	Go to Trouble Diagnosis Procedure for Insufficient Heating.	<a href="#">HAC-92</a>
Noise	Go to Trouble Diagnosis Procedure for Noise.	<a href="#">HAC-94</a>
Self-diagnosis cannot be performed.	Go to Trouble Diagnosis Procedure for Self-diagnosis.	<a href="#">HAC-70</a>
Memory function does not operate.	Go to Trouble Diagnosis Procedure for Memory Function.	<a href="#">HAC-96</a>

A  
B  
C  
D  
E  
F  
G  
H  
HAC  
J  
K  
L  
M  
N  
O  
P

# INSUFFICIENT COOLING

< SYMPTOM DIAGNOSIS >

[AUTOMATIC AIR CONDITIONER]

## INSUFFICIENT COOLING

### Component Function Check

INFOID:000000001611841

SYMPTOM: Insufficient cooling

#### INSPECTION FLOW

### 1. CONFIRM SYMPTOM BY PERFORMING OPERATIONAL CHECK - TEMPERATURE DECREASE

---

1. Press the AUTO switch.
2. Turn temperature control dial (driver) counterclockwise until 16° C (60° F) is displayed.
3. Check for cold air at discharge air outlets.

Can the symptom be duplicated?

- YES >> GO TO 3.  
NO >> GO TO 2.

### 2. CHECK FOR ANY SYMPTOMS

---

Perform a complete operational check for any symptoms. Refer to [HAC-7, "Operational Check"](#).

Does another symptom exist?

- YES >> Refer to [HAC-83, "Symptom Matrix Chart"](#).  
NO >> System OK.

### 3. CHECK FOR SERVICE BULLETINS

---

Check for any service bulletins.

>> GO TO 3.

### 4. PERFORM SELF-DIAGNOSIS

---

Perform self-diagnosis Refer to [HAC-21, "Front Air Control Self-Diagnosis"](#).

Is the inspection result normal?

- YES >> GO TO 5.  
NO >> Refer to [HAC-21, "Front Air Control Self-Diagnosis Code Chart"](#).

### 5. CHECK DRIVE BELTS

---

Check compressor belt tension. Refer to [EM-12, "Checking Drive Belts"](#).

Is the inspection result normal?

- OK >> GO TO 6.  
NG >> Adjust or replace compressor belt. Refer to [EM-12, "Removal and Installation"](#).

### 6. CHECK AIR MIX DOOR OPERATION

---

Check and verify air mix door mechanism for smooth operation. Refer to [HAC-29, "Air Mix Door Motor Component Function Check"](#)

Does air mix door operate correctly?

- YES >> GO TO 7.  
NO >> Check air mix door motor circuit. Refer to [HAC-30, "Air Mix Door Motor \(Driver\) Diagnosis Procedure"](#) or [HAC-33, "Air Mix Door Motor \(Passenger\) Diagnosis Procedure"](#).

### 7. CHECK COOLING FAN MOTOR OPERATION

---

Check and verify cooling fan motor for smooth operation. Refer to [EC-386, "Component Inspection"](#).

Does cooling fan motor operate correctly?

- YES >> GO TO 8.  
NO >> Check cooling fan motor. Refer to [EC-386, "Diagnosis Procedure"](#).

### 8. CHECK WATER VALVE OPERATION

---

Check and verify water valve for smooth operation. Refer to [HAC-58, "Description"](#).

Does water valve operate correctly?

- YES >> GO TO 8.

# INSUFFICIENT COOLING

[AUTOMATIC AIR CONDITIONER]

< SYMPTOM DIAGNOSIS >

NO >> Check water valve circuit. Refer to [HAC-58. "Water Valve Diagnosis Procedure"](#).

## 9.CHECK RECOVERY/RECYCLING EQUIPMENT BEFORE USAGE

Check recovery/recycling equipment before connecting to vehicle. Verify there is no pressure in the recovery/recycling equipment by checking the gauges. If pressure exists, recover refrigerant from equipment lines.

>> GO TO 9.

## 10.CHECK REFRIGERANT PURITY

1. Connect recovery/recycling equipment to vehicle.
2. Confirm refrigerant purity in supply tank using recovery/recycling and refrigerant identifier.

Is the inspection result normal?

YES >> GO TO 10.

NO >> Check contaminated refrigerant. Refer to [HAC-97. "Working with HFC-134a \(R-134a\)"](#).

## 11.CHECK FOR EVAPORATOR FREEZE UP

Start engine and run A/C. Check for evaporator freeze up.

Does evaporator freeze up?

YES >> Perform performance test diagnoses. Refer to [HAC-85. "Performance Test Diagnoses"](#).

NO >> GO TO 11.

## 12.CHECK REFRIGERANT PRESSURE

Check refrigerant pressure with manifold gauge connected. Refer to [HAC-88. "Test Reading"](#).

Is the inspection result normal?

YES >> Perform performance test diagnoses. Refer to [HAC-85. "Performance Test Diagnoses"](#).

NO >> GO TO 12.

## 13.CHECK AIR DUCTS

Check ducts for air leaks.

Is the inspection result normal?

YES >> System OK.

NO >> Repair air leaks.

## Performance Test Diagnoses

INFOID:000000001611842

A  
B  
C  
D  
E  
F  
G  
H  
J  
K  
L  
M  
N  
O  
P

HAC

# INSUFFICIENT COOLING

< SYMPTOM DIAGNOSIS >

[AUTOMATIC AIR CONDITIONER]

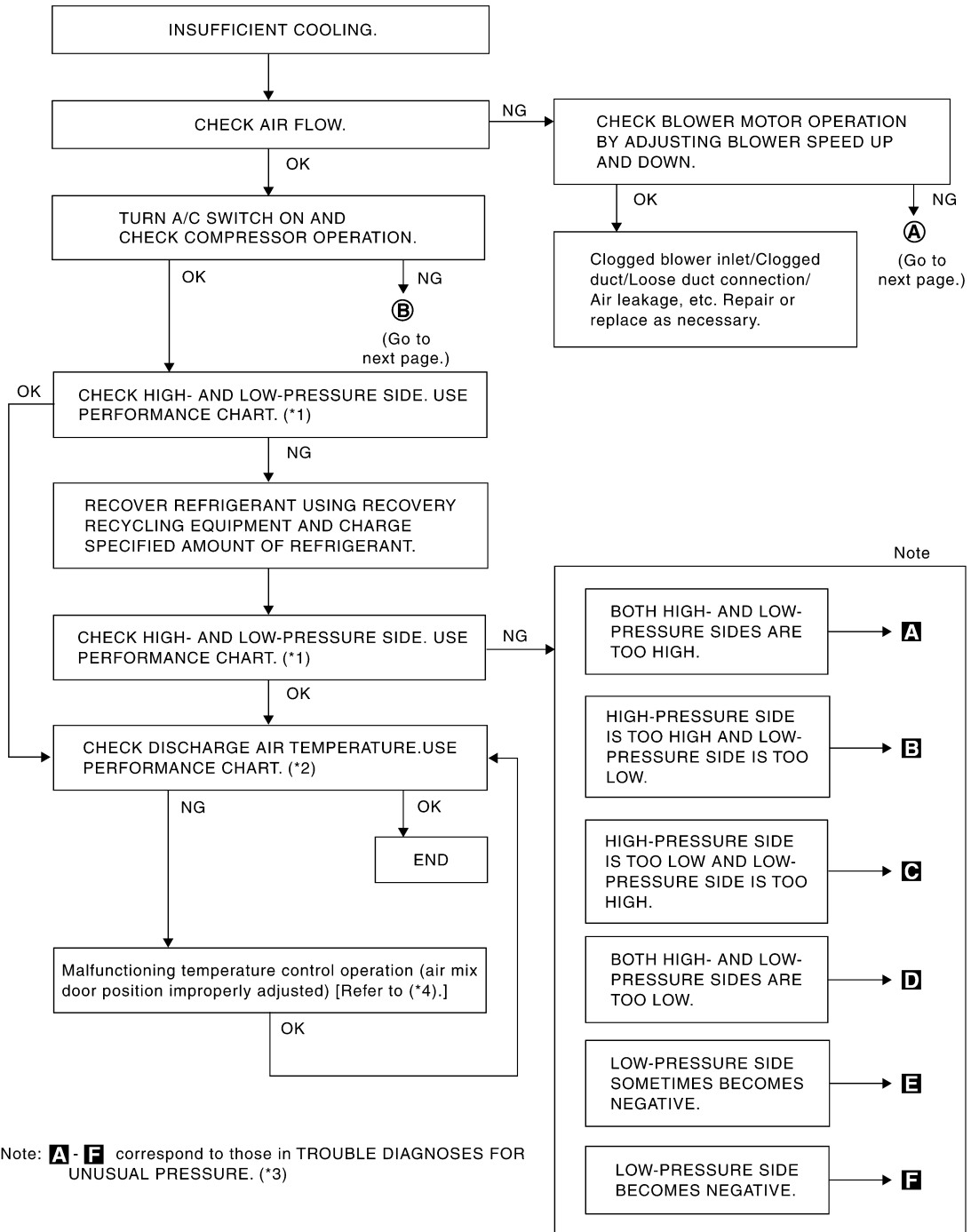

RJA1601E

\*1 [HAC-87. "Performance Chart"](#)

\*2 [HAC-88. "Test Reading"](#)

\*3 [HAC-89. "Trouble Diagnoses for Unusual Pressure"](#)

\*4 [HAC-29. "Air Mix Door Motor Component Function Check"](#)

# INSUFFICIENT COOLING

< SYMPTOM DIAGNOSIS >

[AUTOMATIC AIR CONDITIONER]

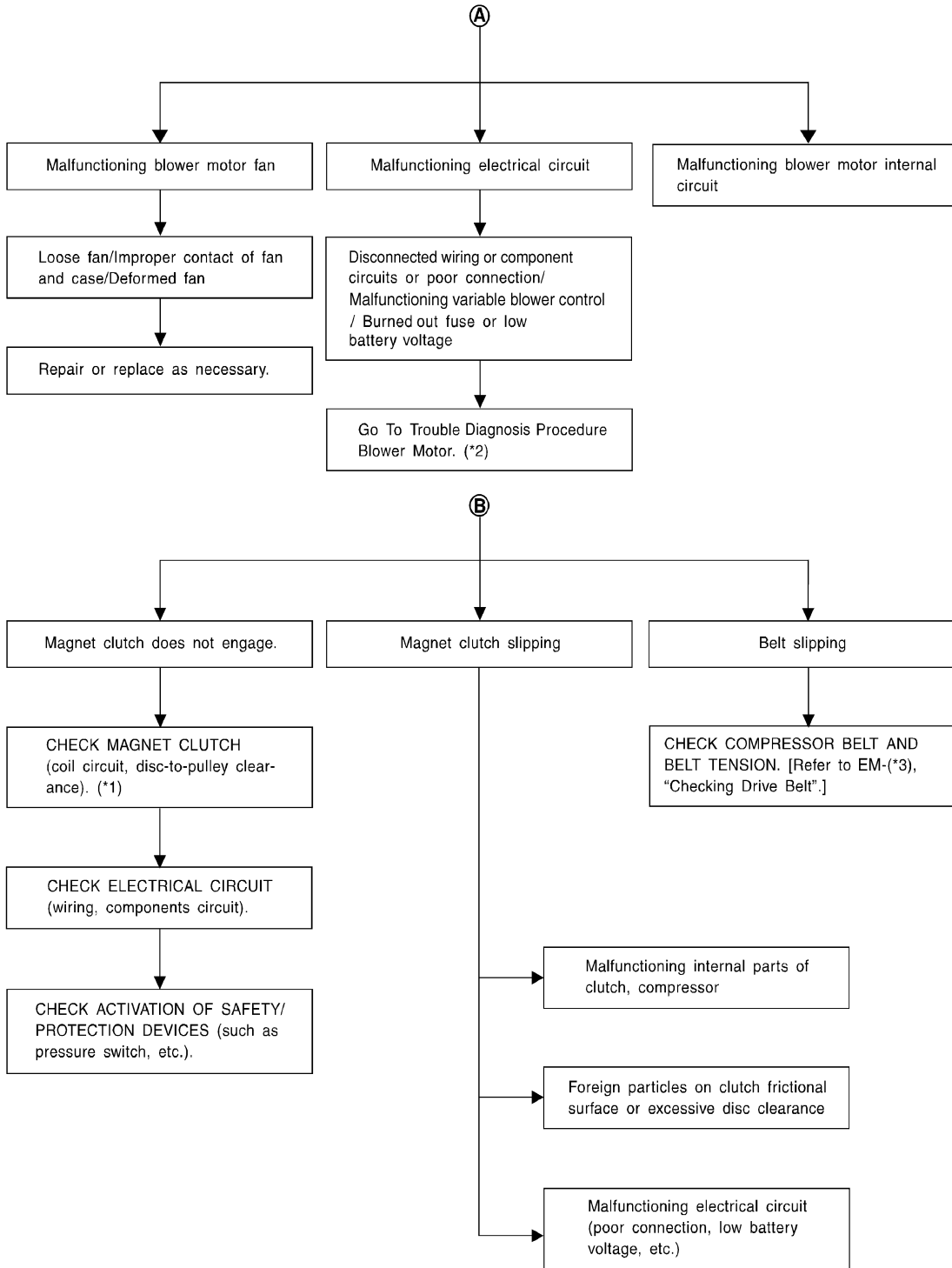

A  
B  
C  
D  
E  
F  
G  
H  
I  
J  
K  
L  
M  
N  
O  
P

HAC

WJIA1371E

\*1 [HA-34. "Removal and Installation for Compressor Clutch"](#)

\*2 [HAC-47. "Front Blower Motor Component Function Check"](#)

\*3 [EM-12. "Checking Drive Belts"](#)

## Performance Chart

INFOID:000000001611843



Test Condition

# INSUFFICIENT COOLING

< SYMPTOM DIAGNOSIS >

[AUTOMATIC AIR CONDITIONER]

Testing must be performed as follows:

Vehicle location	Indoors or in the shade (in a well-ventilated place)
Doors	Closed
Door window	Open
Hood	Open
TEMP.	Max. COLD
Mode switch	 (Ventilation) set
Recirculation (REC) switch	 (Recirculation) set
 Blower speed	Max. speed set
Engine speed	Idle speed

Operate the air conditioning system for 10 minutes before taking measurements.

## Test Reading

INFOID:000000001611844

### Recirculating-to-discharge Air Temperature Table

Inside air (Recirculating air) at blower assembly inlet		Discharge air temperature at center ventilator °C (°F)
Relative humidity %	Air temperature °C (°F)	
50 - 60	20 (68)	9.9 - 13.9 (50 - 57)
	25 (77)	14.6 - 18.6 (58 - 65)
	30 (86)	16.8 - 21.8 (62 - 71)
	35 (95)	21.1 - 27.1 (70 - 81)
	40 (104)	25.3 - 31.5 (78 - 89)
60 - 70	20 (68)	11.4 - 15.2 (53 - 59)
	25 (77)	15.5 - 20.0 (60 - 68)
	30 (86)	19.9 - 25.0 (68 - 77)
	35 (95)	24.5 - 29.6 (76 - 85)
	40 (104)	28.7 - 34.9 (84 - 95)

### Ambient Air Temperature-to-operating Pressure Table

Ambient air		High-pressure (Discharge side) kPa (kg/cm <sup>2</sup> , psi)	Low-pressure (Suction side) kPa (kg/cm <sup>2</sup> , psi)
Relative humidity %	Air temperature °C (°F)		
50 - 70	20 (68)	1020 - 1250 (10.4 - 12.7, 147.9 - 181.3)	160 - 190 (1.63 - 1.94, 23.2 - 27.6)
	25 (77)	1236 - 1510 (12.6 - 15.4, 179.2 - 219)	206 - 245 (2.1 - 2.5, 29.9 - 35.6)
	30 (86)	1569 - 1,922 (16.0 - 19.6, 227.6 - 278.8)	265 - 324 (2.7 - 3.3, 38.4 - 46.9)
	35 (95)	1,697 - 2079 (17.3 - 21.2, 246.1 - 301.5)	304 - 363 (3.1 - 3.7, 44.1 - 52.6)
	40 (104)	1971 - 2403 (20.1 - 24.5, 285.9 - 348.5)	373 - 451 (3.8 - 4.6, 54.0 - 65.4)



# INSUFFICIENT COOLING

< SYMPTOM DIAGNOSIS >

[AUTOMATIC AIR CONDITIONER]

## Trouble Diagnoses for Unusual Pressure

INFOID:000000001611845

Whenever system's high and/or low side pressure is unusual, diagnose using a manifold gauge. The marker above the gauge scale in the following tables indicates the standard (usual) pressure range. Since the standard (usual) pressure, however, differs from vehicle to vehicle, refer to above table (Ambient air temperature-to-operating pressure table).

### Both High- and Low-pressure Sides are Too High

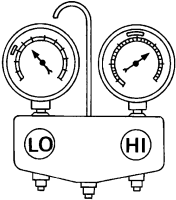
Gauge indication	Refrigerant cycle	Probable cause	Corrective action
<p>Both high- and low-pressure sides are too high.</p>  <p>AC359A</p>	Pressure is reduced soon after water is splashed on condenser.	Excessive refrigerant charge in refrigeration cycle	Reduce refrigerant until specified pressure is obtained.
	Air suction by cooling fan is insufficient.	Insufficient condenser cooling performance ↓ 1. Condenser fins are clogged. 2. Improper fan rotation of cooling fan	<ul style="list-style-type: none"> <li>Clean condenser.</li> <li>Check and repair cooling fan if necessary.</li> </ul>
	<ul style="list-style-type: none"> <li>Low-pressure pipe is not cold.</li> <li>When compressor is stopped high-pressure value quickly drops by approximately 196 kPa (2 kg/cm<sup>2</sup>, 28 psi). It then decreases gradually thereafter.</li> </ul>	Poor heat exchange in condenser (After compressor operation stops, high-pressure decreases too slowly.) ↓ Air in refrigeration cycle	Evacuate and recharge system.
	Engine tends to overheat.	Engine cooling systems malfunction.	Check and repair engine cooling system.
	<ul style="list-style-type: none"> <li>An area of the low-pressure pipe is colder than areas near the evaporator outlet.</li> <li>Plates are sometimes covered with frost.</li> </ul>	<ul style="list-style-type: none"> <li>Excessive liquid refrigerant on low-pressure side</li> <li>Excessive refrigerant discharge flow</li> <li>Expansion valve is open a little compared with the specification.</li> </ul> ↓ Improper expansion valve adjustment	Replace expansion valve.

### High-pressure Side is Too High and Low-pressure Side is Too Low

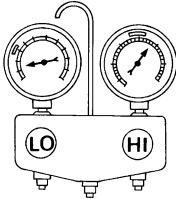
Gauge indication	Refrigerant cycle	Probable cause	Corrective action
<p>High-pressure side is too high and low-pressure side is too low.</p>  <p>AC360A</p>	Upper side of condenser and high-pressure side are hot, however, liquid tank is not so hot.	High-pressure tube or parts located between compressor and condenser are clogged or crushed.	<ul style="list-style-type: none"> <li>Check and repair or replace malfunctioning parts.</li> <li>Check oil for contamination.</li> </ul>

### High-pressure Side is Too Low and Low-pressure Side is Too High

# INSUFFICIENT COOLING

< SYMPTOM DIAGNOSIS >

[AUTOMATIC AIR CONDITIONER]

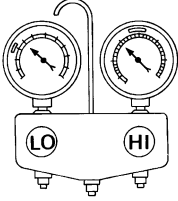
Gauge indication	Refrigerant cycle	Probable cause	Corrective action
High-pressure side is too low and low-pressure side is too high.   AC356A	High- and low-pressure sides become equal soon after compressor operation stops.	Compressor pressure operation is improper. ↓ Damaged inside compressor packings.	Replace compressor.
	No temperature difference between high- and low-pressure sides.	Compressor pressure operation is improper. ↓ Damaged inside compressor packings.	Replace compressor.

## Both High- and Low-pressure Sides are Too Low

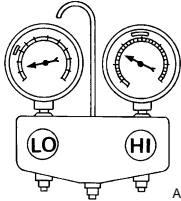
Gauge indication	Refrigerant cycle	Probable cause	Corrective action
Both high- and low-pressure sides are too low.   AC353A	<ul style="list-style-type: none"> <li>There is a big temperature difference between liquid tank outlet and inlet. Outlet temperature is extremely low.</li> <li>Liquid tank inlet and expansion valve are frosted.</li> </ul>	Liquid tank inside is slightly clogged.	<ul style="list-style-type: none"> <li>Replace liquid tank.</li> <li>Check oil for contamination.</li> </ul>
	<ul style="list-style-type: none"> <li>Temperature of expansion valve inlet is extremely low as compared with areas near liquid tank.</li> <li>Expansion valve inlet may be frosted.</li> <li>Temperature difference occurs somewhere in high-pressure side.</li> </ul>	High-pressure pipe located between liquid tank and expansion valve is clogged.	<ul style="list-style-type: none"> <li>Check and repair malfunctioning parts.</li> <li>Check oil for contamination.</li> </ul>
	Expansion valve and liquid tank are warm or only cool when touched.	Low refrigerant charge. ↓ Leaking fittings or components.	Check refrigerant system for leaks. Refer to <a href="#">HA-23, "Checking of Refrigerant Leaks"</a> .
	There is a big temperature difference between expansion valve inlet and outlet while the valve itself is frosted.	Expansion valve closes a little compared with the specification. ↓ 1. Improper expansion valve adjustment. 2. Malfunctioning expansion valve. 3. Outlet and inlet may be clogged.	<ul style="list-style-type: none"> <li>Remove foreign particles by using compressed air.</li> <li>Check oil for contamination.</li> </ul>
	An area of the low-pressure pipe is colder than areas near the evaporator outlet.	Low-pressure pipe is clogged or crushed.	<ul style="list-style-type: none"> <li>Check and repair malfunctioning parts.</li> <li>Check oil for contamination.</li> </ul>
	Air flow volume is too low.	Evaporator is frozen.	<ul style="list-style-type: none"> <li>Check intake sensor circuit. Refer to <a href="#">HAC-68, "Intake Sensor Diagnosis Procedure"</a>.</li> <li>Repair evaporator fins.</li> <li>Replace evaporator.</li> <li>Refer to <a href="#">HAC-47, "Front Blower Motor Component Function Check"</a>.</li> </ul>

Low-pressure Side Sometimes Becomes Negative

# INSUFFICIENT COOLING

< SYMPTOM DIAGNOSIS >

[AUTOMATIC AIR CONDITIONER]

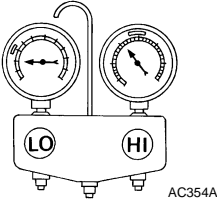
Gauge indication	Refrigerant cycle	Probable cause	Corrective action
<p>Low-pressure side sometimes becomes negative.</p>  <p style="text-align: right; font-size: small;">AC354A</p>	<ul style="list-style-type: none"> <li>• Air conditioning system does not function and does not cyclically cool the compartment air.</li> <li>• The system constantly functions for a certain period of time after compressor is stopped and restarted.</li> </ul>	<p>Refrigerant does not discharge cyclically.</p> <p>↓</p> <p>Moisture is frozen at expansion valve outlet and inlet.</p> <p>↓</p> <p>Water is mixed with refrigerant.</p>	<ul style="list-style-type: none"> <li>• Drain water from refrigerant or replace refrigerant.</li> <li>• Replace liquid tank.</li> </ul>

## Low-pressure Side Becomes Negative

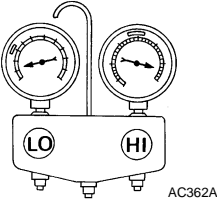
Gauge indication	Refrigerant cycle	Probable cause	Corrective action
<p>Low-pressure side becomes negative.</p>  <p style="text-align: right; font-size: small;">AC362A</p>	<p>Liquid tank or front/rear side of expansion valve's pipe is frosted or dewed.</p>	<p>High-pressure side is closed and refrigerant does not flow.</p> <p>↓</p> <p>Expansion valve or liquid tank is frosted.</p>	<p>Leave the system at rest until no frost is present. Start it again to check whether or not the malfunction is caused by water or foreign particles.</p> <ul style="list-style-type: none"> <li>• If water is the cause, initially cooling is okay. Then the water freezes causing a blockage. Drain water from refrigerant or replace refrigerant.</li> <li>• If due to foreign particles, remove expansion valve and remove the particles with dry and compressed air (not shop air).</li> <li>• If either of the above methods cannot correct the malfunction, replace expansion valve.</li> <li>• Replace liquid tank.</li> <li>• Check oil for contamination.</li> </ul>

A  
B  
C  
D  
E  
F  
G  
H  
HAC  
J  
K  
L  
M  
N  
O  
P

# INSUFFICIENT HEATING

< SYMPTOM DIAGNOSIS >

[AUTOMATIC AIR CONDITIONER]

## INSUFFICIENT HEATING

### Component Function Check

INFOID:000000001611846

SYMPTOM: Insufficient heating

#### INSPECTION FLOW

### 1. CONFIRM SYMPTOM BY PERFORMING OPERATIONAL CHECK - TEMPERATURE INCREASE

---

1. Press the AUTO switch.
2. Turn the temperature control dial (driver) clockwise until 32° C (90° F) is displayed.
3. Check for hot air at discharge air outlets.

Can this symptom be duplicated?

- YES >> GO TO 2.  
NO >> Perform complete system operational check. Refer to [HAC-7, "Operational Check"](#).

### 2. CHECK FOR SERVICE BULLETINS

---

Check for any service bulletins.

>> GO TO 3.

### 3. PERFORM SELF-DIAGNOSIS

---

Perform self-diagnosis. Refer to [HAC-21, "Front Air Control Self-Diagnosis"](#).

Is the inspection results normal?

- YES >> GO TO 4.  
NO >> Refer to [HAC-21, "Front Air Control Self-Diagnosis Code Chart"](#).

### 4. CHECK ENGINE COOLING SYSTEM

---

1. Check for proper engine coolant level. Refer to [CO-10, "Inspection"](#).
2. Check hoses for leaks or kinks.
3. Check radiator cap. Refer to [CO-10, "Inspection"](#).
4. Check for air in cooling system.

>> GO TO 5.

### 5. CHECK AIR MIX DOOR OPERATION

---

Check the operation of the air mix door.

Is the inspection result normal?

- YES >> GO TO 6.  
NO >> Check the air mix door motor circuit. Refer to [HAC-29, "Air Mix Door Motor Component Function Check"](#).

### 6. CHECK AIR DUCTS

---

Check for disconnected or leaking air ducts.

Is the inspection result normal?

- YES >> GO TO 7.  
NO >> Repair all disconnected or leaking air ducts.

### 7. CHECK HEATER HOSE TEMPERATURES

---

1. Start engine and warm it up to normal operating temperature.
2. Touch both the inlet and outlet heater hoses.

Is the inspection result normal?

- YES >> Hot inlet hose and a warm outlet hose: GO TO 8.  
NO >> • Inlet hose cold: GO TO 11.  
• Both hoses warm: GO TO 9.

### 8. CHECK ENGINE COOLANT SYSTEM

---

Check engine control temperature sensor. Refer to [EC-126, "Component Inspection"](#).

# INSUFFICIENT HEATING

[AUTOMATIC AIR CONDITIONER]

## < SYMPTOM DIAGNOSIS >

Is the inspection result normal?

YES >> System OK.

NO >> Repair or replace as necessary. Retest.

### 9.CHECK HEATER HOSES

Check heater hoses for proper installation.

Is the inspection result normal?

YES >> System OK.

NO >> 1. Back flush heater core.

2. Drain the water from the system.

3. Refill system with new engine coolant. Refer to [CO-11, "Changing Engine Coolant"](#).

4. GO TO 10 to retest.

### 10.CHECK HEATER HOSE TEMPERATURES

1. Start engine and warm it up to normal operating temperature.

2. Touch both the inlet and outlet heater hoses.

Is the inspection result normal?

YES >> System OK.

NO >> Replace heater core. Refer to [VTL-15, "Removal and Installation"](#).

### 11.CHECK WATER VALVE

Check the operation of the water valve. Refer to [HAC-58, "Water Valve Diagnosis Procedure"](#).

Is the inspection result normal?

YES >> System OK.

NO >> Replace water valve.

A

B

C

D

E

F

G

H

HAC

J

K

L

M

N

O

P

## NOISE

### Component Function Check

INFOID:000000001611847

SYMPTOM: Noise

### INSPECTION FLOW

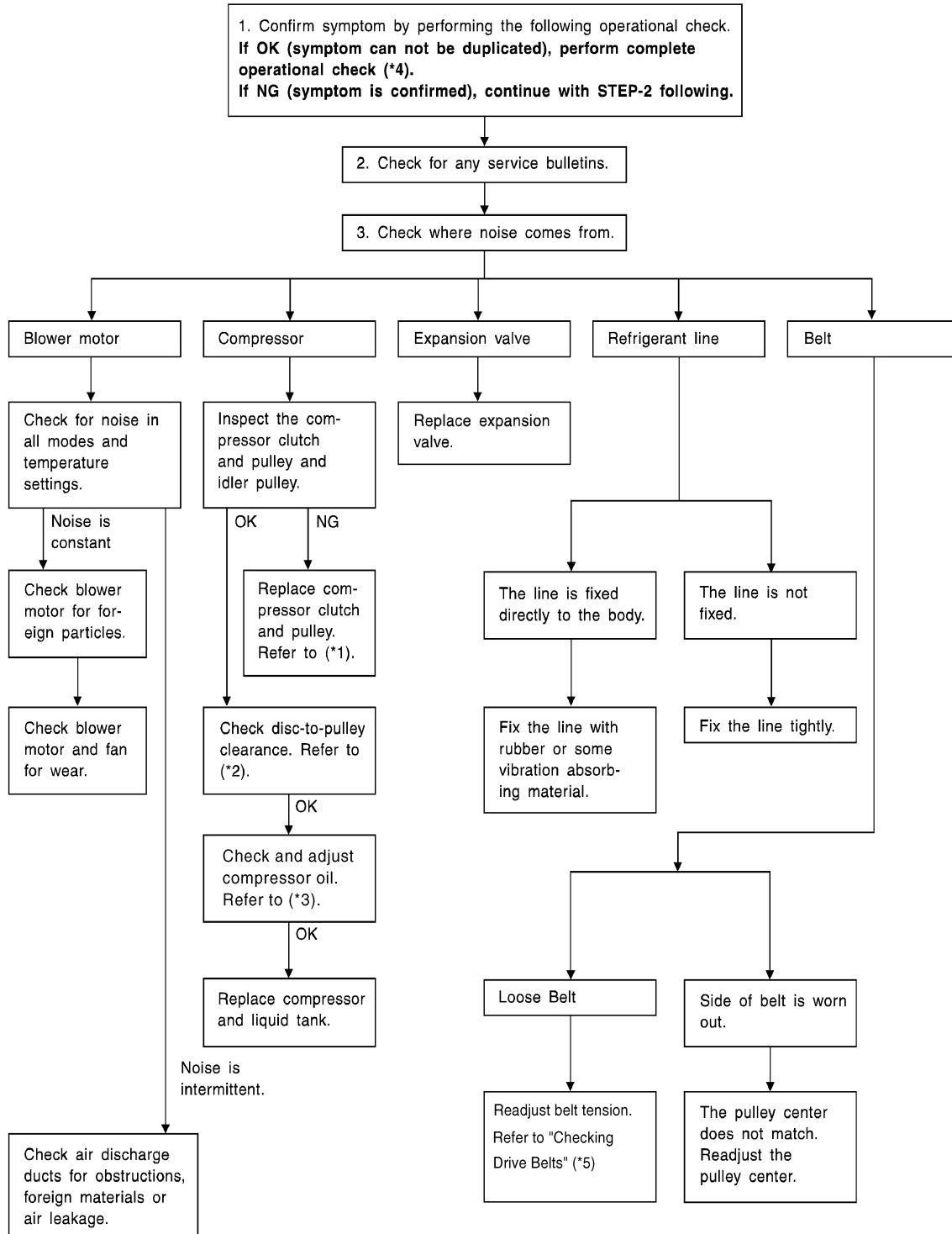

# NOISE

< SYMPTOM DIAGNOSIS >

[AUTOMATIC AIR CONDITIONER]

- |    |   |    |   |    |  |   |
|----|---|----|---|----|--|---|
| *1 | <a href="#">HA-34. "Removal and Installation for Compressor Clutch"</a> | *2 | <a href="#">HA-34. "Removal and Installation for Compressor Clutch"</a> | *3 | <a href="#">HA-20. "Maintenance of Oil Quantity in Compressor"</a> | A |
| *4 | <a href="#">HAC-7. "Operational Check"</a>                              | *5 | <a href="#">EM-12. "Checking Drive Belts"</a>                           |    |  | B |

B

C

D

E

F

G

H

HAC

J

K

L

M

N

O

P

# MEMORY FUNCTION DOES NOT OPERATE

< SYMPTOM DIAGNOSIS >

[AUTOMATIC AIR CONDITIONER]

## MEMORY FUNCTION DOES NOT OPERATE

### Memory Function Check

INFOID:000000001611848

SYMPTOM: Memory function does not operate.

#### INSPECTION FLOW

### 1. CONFIRM SYMPTOM BY PERFORMING OPERATIONAL CHECK - MEMORY FUNCTION

---

1. Set the temperature to 32°C (90°F).
2. Rotate the front blower control dial (driver) to turn system OFF.
3. Turn ignition switch OFF.
4. Turn ignition switch ON.
5. Press the AUTO switch.
6. Confirm that the set temperature remains at previous temperature.
7. Press the OFF switch.

#### Can the symptom be duplicated?

- YES >> GO TO 3.  
NO >> GO TO 2.

### 2. PERFORM COMPLETE OPERATIONAL CHECK

---

Perform a complete operational check and check for any symptoms. Refer to [HAC-7, "Operational Check"](#).

#### Can a symptom be duplicated?

- YES >> Refer to [HAC-6, "How to Perform Trouble Diagnosis For Quick And Accurate Repair"](#).  
NO >> System OK.

### 3. CHECK FOR SERVICE BULLETINS

---

Check for any service bulletins.

>> GO TO 4.

### 4. PERFORM SELF-DIAGNOSIS

---

Perform self-diagnosis to check for any codes. Refer to [HAC-21, "Front Air Control Self-Diagnosis"](#).

#### Are any self-diagnosis codes present?

- YES >> Refer to [HAC-21, "Front Air Control Self-Diagnosis Code Chart"](#).  
NO >> GO TO 5.

### 5. CHECK POWER AND GROUND CIRCUIT

---

Check main power supply and ground circuit. Refer to [HAC-70, "Front Air Control Component Function Check"](#).

#### Is the inspection result normal?

- YES >> GO TO 6.  
NO >> Repair or replace as necessary.

### 6. RECHECK FOR SYMPTOMS

---

Perform a complete operational check for any symptoms. Refer to [HAC-7, "Operational Check"](#).

#### Does another symptom exist?

- YES >> Refer to [HAC-6, "How to Perform Trouble Diagnosis For Quick And Accurate Repair"](#).  
NO >> Replace Front air control. Refer to [VTL-8, "Removal and Installation"](#).



## PRECAUTION

### PRECAUTIONS

#### Supplemental Restraint System (SRS) "AIR BAG" and "SEAT BELT PRE-TENSIONER"

INFOID:000000001611849

The Supplemental Restraint System such as "AIR BAG" and "SEAT BELT PRE-TENSIONER", used along with a front seat belt, helps to reduce the risk or severity of injury to the driver and front passenger for certain types of collision. This system includes seat belt switch inputs and dual stage front air bag modules. The SRS system uses the seat belt switches to determine the front air bag deployment, and may only deploy one front air bag, depending on the severity of a collision and whether the front occupants are belted or unbelted. Information necessary to service the system safely is included in the SR and SB section of this Service Manual.

**WARNING:**

- To avoid rendering the SRS inoperative, which could increase the risk of personal injury or death in the event of a collision which would result in air bag inflation, all maintenance must be performed by an authorized NISSAN/INFINITI dealer.
- Improper maintenance, including incorrect removal and installation of the SRS, can lead to personal injury caused by unintentional activation of the system. For removal of Spiral Cable and Air Bag Module, see the SR section.
- Do not use electrical test equipment on any circuit related to the SRS unless instructed to in this Service Manual. SRS wiring harnesses can be identified by yellow and/or orange harnesses or harness connectors.

#### Working with HFC-134a (R-134a)

INFOID:000000001611850

**WARNING:**

- CFC-12 (R-12) refrigerant and HFC-134a (R-134a) refrigerant are not compatible. If the refrigerants are mixed compressor failure is likely to occur. Refer to [HA-4, "Contaminated Refrigerant"](#). To determine the purity of HFC-134a (R-134a) in the vehicle and recovery tank, use Refrigerant Recovery/Recycling Recharging equipment and Refrigerant Identifier.
- Use only specified oil for the HFC-134a (R-134a) A/C system and HFC-134a (R-134a) components. If oil other than that specified is used, compressor failure is likely to occur.
- The specified HFC-134a (R-134a) oil rapidly absorbs moisture from the atmosphere. The following handling precautions must be observed:
  - When removing refrigerant components from a vehicle, immediately cap (seal) the component to minimize the entry of moisture from the atmosphere.
  - When installing refrigerant components to a vehicle, do not remove the caps (unseal) until just before connecting the components. Connect all refrigerant loop components as quickly as possible to minimize the entry of moisture into system.
  - Only use the specified oil from a sealed container. Immediately reseal containers of oil. Without proper sealing, oil will become moisture saturated and should not be used.
  - Avoid breathing A/C refrigerant and oil vapor or mist. Exposure may irritate eyes, nose and throat. Remove HFC-134a (R-134a) from the A/C system using certified service equipment meeting requirements of SAE J2210 [HFC-134a (R-134a) recycling equipment], or J2209 [HFC-134a (R-134a) recycling equipment], If accidental system discharge occurs, ventilate work area before resuming service. Additional health and safety information may be obtained from refrigerant and oil manufacturers.
  - Do not allow A/C oil to come in contact with styrofoam parts. Damage may result.

#### CONTAMINATED REFRIGERANT

If a refrigerant other than pure HFC-134a (R-134a) is identified in a vehicle, your options are:

- Explain to the customer that environmental regulations prohibit the release of contaminated refrigerant into the atmosphere.
- Explain that recovery of the contaminated refrigerant could damage your service equipment and refrigerant supply.
- Suggest the customer return the vehicle to the location of previous service where the contamination may have occurred.
- If you choose to perform the repair, recover the refrigerant using only **dedicated equipment and containers. Do not recover contaminated refrigerant into your existing service equipment.** If your facility does

# PRECAUTIONS

## [AUTOMATIC AIR CONDITIONER]

### < PRECAUTION >

not have dedicated recovery equipment, you may contact a local refrigerant product retailer for available service. This refrigerant must be disposed of in accordance with all federal and local regulations. In addition, replacement of all refrigerant system components on the vehicle is recommended.

- If the vehicle is within the warranty period, the air conditioner warranty is void. Please contact NISSAN Customer Affairs for further assistance.

### Precaution for Service Equipment

INFOID:000000001611851

#### MANIFOLD GAUGE SET

Be certain that the gauge face indicates R-134a or 134a. Make sure the gauge set has 1/2"-16 ACME threaded connections for service hoses. Confirm the set has been used only with refrigerant HFC-134a (R-134a) along with specified oil.

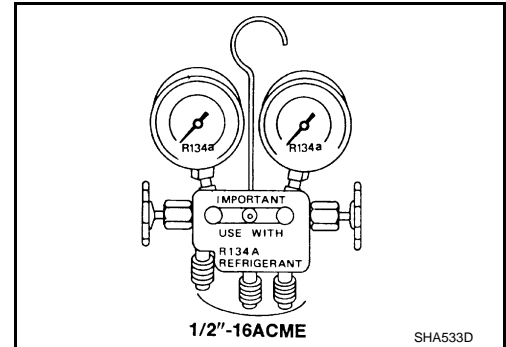

#### SERVICE HOSES

Be certain that the service hoses display the markings described (colored hose with black stripe). All hoses must include positive shut-off devices (either manual or automatic) near the end of the hoses opposite the manifold gauge.

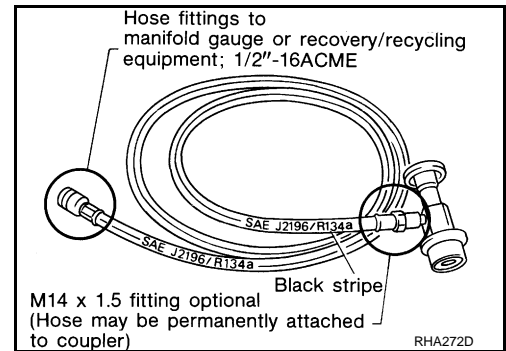

#### SERVICE COUPLERS

Never attempt to connect HFC-134a (R-134a) service couplers to a CFC-12 (R-12) A/C system. The HFC-134a (R-134a) couplers will not properly connect to the CFC-12 (R-12) system. However, if an improper connection is attempted, discharging and contamination may occur.

Shut-off valve rotation	A/C service valve
Clockwise	Open
Counterclockwise	Close

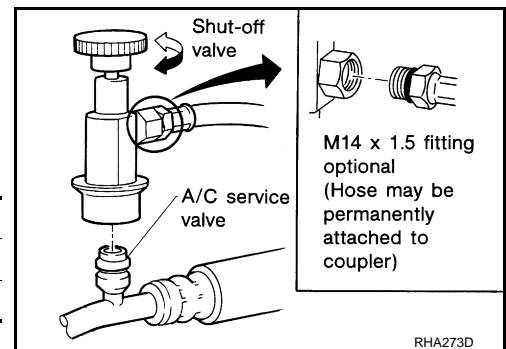

# MANUAL A/C IDENTIFICATION TABLE

< BASIC INSPECTION >

[MANUAL A/C (TYPE 1)]

## BASIC INSPECTION

### MANUAL A/C IDENTIFICATION TABLE

#### Application Table

INFOID:000000001678219

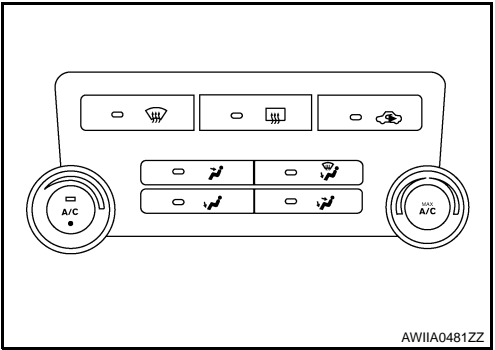
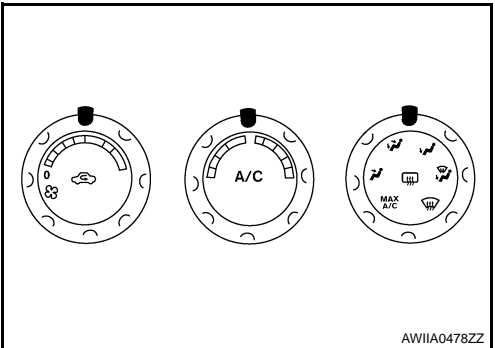
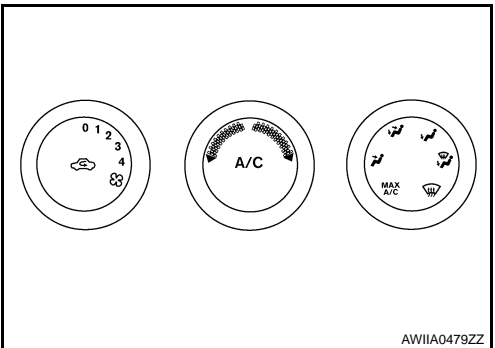
Manual A/C Type	Description	Visual Identification
Manual A/C (Type 1)	Two Control Dial System	
Manual A/C (Type 2)	Three Control Dial System [with variable blower control (VBC)]	
Manual A/C (Type 3)	Three Control Dial System [without variable blower control (VBC)]	

A  
B  
C  
D  
E  
F  
G  
H  
I  
J  
K  
L  
M  
N  
O  
P

HAC

## DIAGNOSIS AND REPAIR WORKFLOW

### How to Perform Trouble Diagnosis For Quick And Accurate Repair

INFOID:000000001669125

#### WORK FLOW

#### 1. LISTEN TO CUSTOMER COMPLAINT

Listen to customer complaint. Get detailed information about the conditions and environment when the symptom occurs.

>> GO TO 2

#### 2. CHECK FOR SERVICE BULLETINS

Check for any service bulletins.

>> GO TO 3.

#### 3. VERIFY THE SYMPTOM WITH OPERATIONAL CHECK

Verify the symptom with operational check. Refer to [HAC-101. "Operational Check"](#).

>> GO TO 4

#### 4. GO TO APPROPRIATE TROUBLE DIAGNOSIS

Go to appropriate trouble diagnosis. Refer to [HAC-166. "Symptom Matrix Chart"](#).

>> If equipped with NAVI, GO TO 5.

>> If equipped without NAVI, GO TO 6.

#### 5. PERFORM THE FRONT AIR CONTROL SELF-DIAGNOSIS

Perform front air control self-diagnosis. Refer to [HAC-21. "Front Air Control Self-Diagnosis"](#).

>> If any diagnostic trouble codes set. Refer to [HAC-21. "Front Air Control Self-Diagnosis Code Chart"](#).

>> Confirm the repair by performing operational check. Refer to [HAC-7. "Operational Check"](#).

#### 6. REPAIR OR REPLACE

Repair or replace the specific parts.

>> GO TO 6

#### 7. FINAL CHECK

Final check.

Is the inspection result normal?

YES >> CHECK OUT

NO >> GO TO 4

## INSPECTION AND ADJUSTMENT

## Operational Check

INFOID:000000001669126

The purpose of the operational check is to confirm that the system operates properly.

**Conditions : Engine running and at normal operating temperature**

## CHECKING BLOWER

1. Rotate the blower control dial clockwise once, blower should operate on low speed.
2. Rotate the blower control dial again, and continue checking blower speed until all speeds are checked.
3. Leave blower on maximum speed.

If NG, go to trouble diagnosis procedure for [HAC-136. "Front Blower Motor Diagnosis Procedure"](#).

If OK, continue with next check.

## CHECKING DISCHARGE AIR

1. Press each MODE switch and the DEF  switch.
2. Each MODE position indicator should illuminate.
3. Confirm that discharge air comes out according to the air distribution table. Refer to [HAC-110. "Discharge Air Flow"](#)  
Mode door position is checked in the next step.



If NG, go to trouble diagnosis procedure for [HAC-118. "Mode Door Motor Diagnosis Procedure"](#).

If OK, continue the check.

**NOTE:**

Confirm that the compressor clutch is engaged (sound or visual inspection) and intake door position is at fresh when the DEF or D/F is selected.





CHECKING RECIRCULATION ( ,  ONLY)

1. Press recirculation (  ) switch one time. Recirculation indicator should illuminate.
2. Press recirculation (  ) switch one more time. Recirculation indicator should go off.
3. Listen for intake door position change (blower sound should change slightly).

If NG, go to trouble diagnosis procedure for [HAC-128. "Intake Door Motor Diagnosis Procedure"](#).

If OK, continue the check.

**NOTE:**

Confirm that the compressor clutch is engaged (sound or visual inspection) and intake door position is at fresh when the DEF or D/F is selected. REC (  ) is not allowed in DEF (  ) D/F (  ) or FOOT (  ).

## CHECKING TEMPERATURE DECREASE

1. Rotate temperature control dial counterclockwise until maximum cold.
2. Check for cold air at appropriate discharge air outlets.

If NG, listen for sound of air mix door motor operation. If OK, go to trouble diagnosis procedure for [HAC-167. "Component Function Check"](#). If air mix door motor appears to be malfunctioning, go to [HAC-123. "Air Mix Door Motor Diagnosis Procedure"](#).

If OK, continue the check.

## CHECKING TEMPERATURE INCREASE

1. Rotate temperature control dial clockwise until maximum hot.
2. Check for hot air at appropriate discharge air outlets.

If NG, listen for sound of air mix door motor operation. If OK, go to trouble diagnosis procedure for [HAC-175. "Component Function Check"](#). If air mix door motor appears to be malfunctioning, go to [HAC-122. "Air Mix Door Motor Component Function Check"](#).

If OK, continue with next check.

## CHECK A/C SWITCH

1. Press A/C switch.
2. A/C switch indicator will turn ON.

## INSPECTION AND ADJUSTMENT

< BASIC INSPECTION >

[MANUAL A/C (TYPE 1)]

---

- Confirm that the compressor clutch engages (sound or visual inspection).

**NOTE:**

If current mode setting is DEF or D/F, compressor clutch will already be engaged and cannot be turned off.

If NG, go to trouble diagnosis procedure for [HAC-142, "Magnet Clutch Diagnosis Procedure"](#).

If all operational checks are OK (symptom cannot be duplicated), go to [HAC-100, "How to Perform Trouble Diagnosis For Quick And Accurate Repair"](#) and perform tests as outlined. If symptom appears, refer to [HAC-166, "Symptom Matrix Chart"](#) and perform applicable trouble diagnosis procedures.

# MANUAL A/C IDENTIFICATION TABLE

< FUNCTION DIAGNOSIS >

[MANUAL A/C (TYPE 1)]

## FUNCTION DIAGNOSIS

### MANUAL A/C IDENTIFICATION TABLE

#### Application Table

INFOID:000000001678220

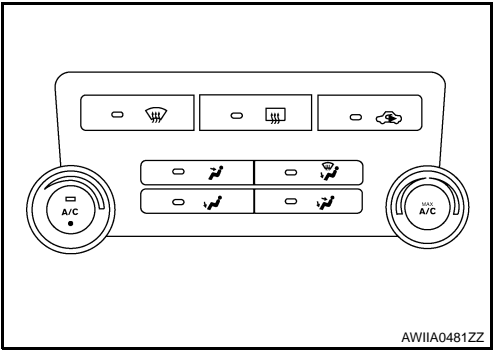
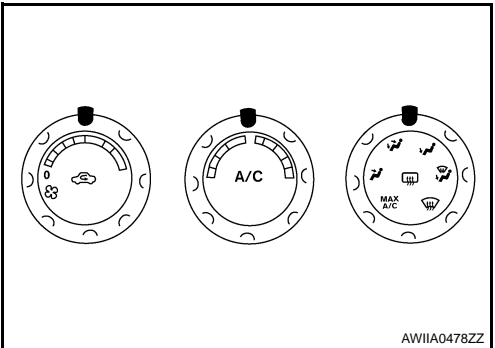
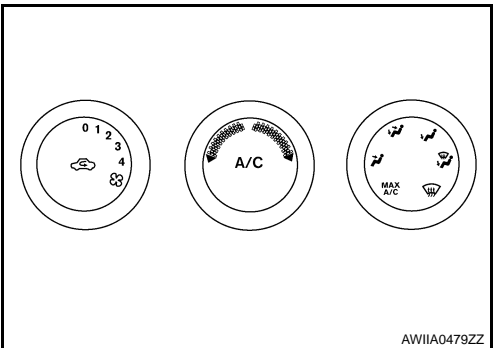
Manual A/C Type	Description	Visual Identification
Manual A/C (Type 1)	Two Control Dial System	
Manual A/C (Type 2)	Three Control Dial System [with variable blower control (VBC)]	
Manual A/C (Type 3)	Three Control Dial System [without variable blower control (VBC)]	

A  
B  
C  
D  
E  
F  
G  
H  
I  
J  
K  
L  
M  
N  
O  
P

HAC

FUNCTION INFORMATION

Component Part Location

INFOID:000000001669127

ENGINE COMPARTMENT

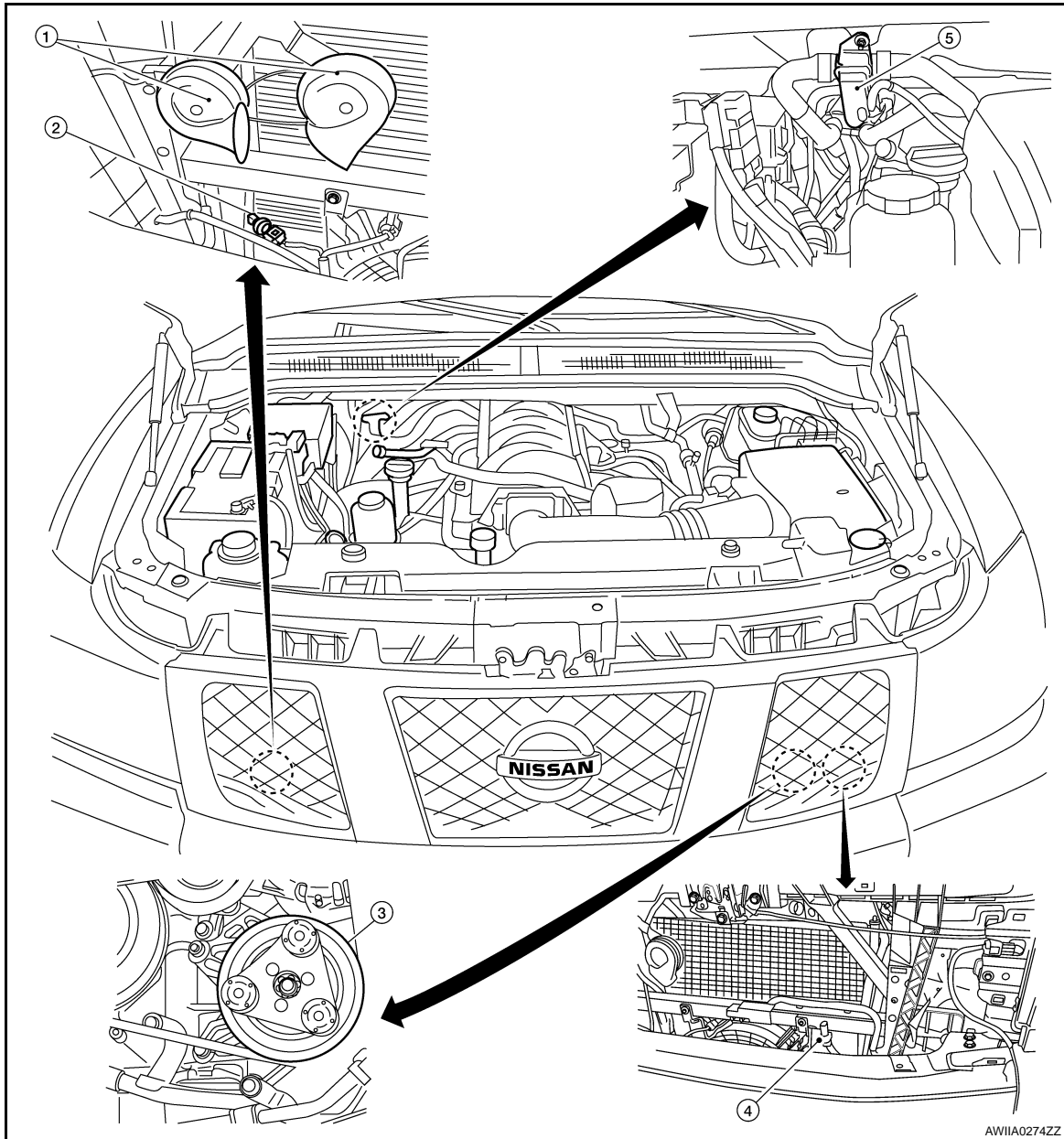

AWIA0274ZZ

- |   |   |                      |
|---|---|----------------------|
| 1. Water valve F68<br>Horn (view with grille removed) | 2. Refrigerant pressure sensor E111<br>(view with grille removed) | 3. A/C Compressor F3 |
| 4. Ambient sensor E1 (view with grille removed)       | 5. Water valve F68  |                      |



## PASSENGER COMPARTMENT

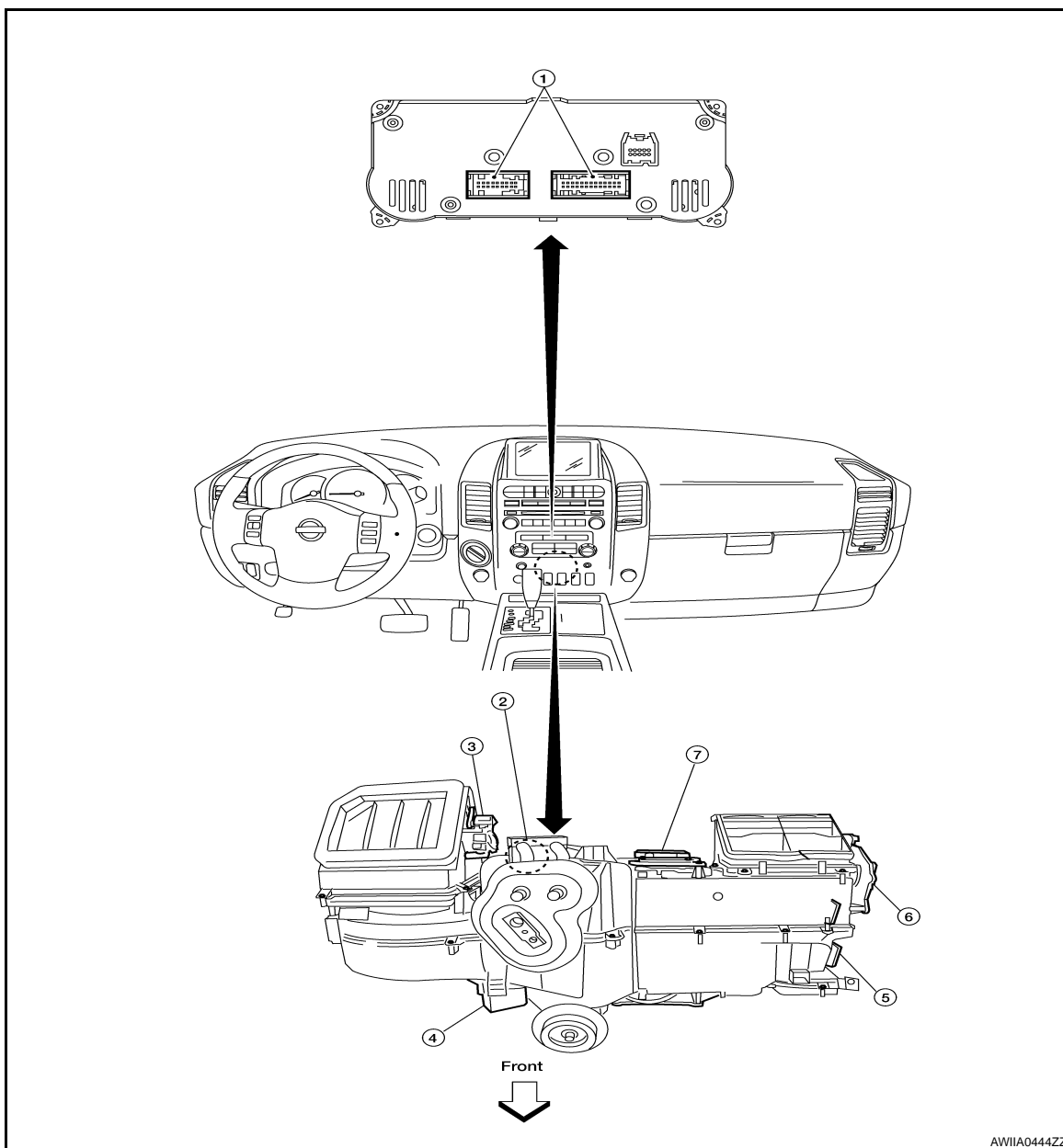

- |                                    |                         |                              |
|------------------------------------|-------------------------|------------------------------|
| 1. Front air control M49, M50      | 2. Intake sensor M146   | 3. Intake door motor M58     |
| 4. Variable blower control M122    | 5. Mode door motor M142 | 6. Defroster door motor M144 |
| 7. Air mix door motor (front) M147 |                         |                              |

A  
B  
C  
D  
E  
F  
G  
H  
HAC  
J  
K  
L  
M  
N  
O  
P

# FUNCTION INFORMATION

< FUNCTION DIAGNOSIS >

[MANUAL A/C (TYPE 1)]

## Symptom Table

INFOID:000000001669128

Symptom	Reference Page	
A/C system does not come on.	Go to Trouble Diagnosis Procedure for A/C System.	<a href="#">HAC-154</a>
A/C system cannot be controlled.	Go to Self-diagnosis Function.	<a href="#">HAC-115</a>
Air outlet does not change.	Go to Trouble Diagnosis Procedure for Mode Door Motor.	<a href="#">HAC-118</a>
Mode door motor is malfunctioning.		
Discharge air temperature does not change.	Go to Trouble Diagnosis Procedure for Air Mix Door Motor.	<a href="#">HAC-122</a>
Air mix door motor is malfunctioning.		
Intake door does not change.	Go to Trouble Diagnosis Procedure for Intake Door Motor.	<a href="#">HAC-128</a>
Intake door motor is malfunctioning.		
Defroster door motor is malfunctioning.	Go to Trouble Diagnosis Procedure for Defroster Door Motor.	<a href="#">HAC-131</a>
Front blower motor operation is malfunctioning.	Go to Trouble Diagnosis Procedure for Front Blower Motor.	<a href="#">HAC-136</a>
Magnet clutch does not engage.	Go to Trouble Diagnosis Procedure for Magnet Clutch.	<a href="#">HAC-142</a>
Insufficient cooling	Go to Trouble Diagnosis Procedure for Insufficient Cooling.	<a href="#">HAC-167</a>
Insufficient heating	Go to Trouble Diagnosis Procedure for Insufficient Heating.	<a href="#">HAC-175</a>
Noise	Go to Trouble Diagnosis Procedure for Noise.	<a href="#">HAC-177</a>
Self-diagnosis cannot be performed.	Go to Trouble Diagnosis Procedure for Self-diagnosis.	<a href="#">HAC-115</a>

REFRIGERATION SYSTEM

Refrigerant Cycle

INFOID:000000001669129

Refer to [HA-15. "Refrigerant Cycle"](#).

Refrigerant System Protection

INFOID:000000001669130

Refer to [HA-15. "Refrigerant System Protection"](#).

A

B

C

D

E

F

G

H

HAC

J

K

L

M

N

O

P

# MANUAL AIR CONDITIONER SYSTEM

< FUNCTION DIAGNOSIS >

[MANUAL A/C (TYPE 1)]

## MANUAL AIR CONDITIONER SYSTEM

### Control System Diagram

INFOID:000000001669131

#### CONTROL SYSTEM

The control system consists of input sensors, switches, the front air control (microcomputer) and outputs. The relationship of these components is shown in the figure below:

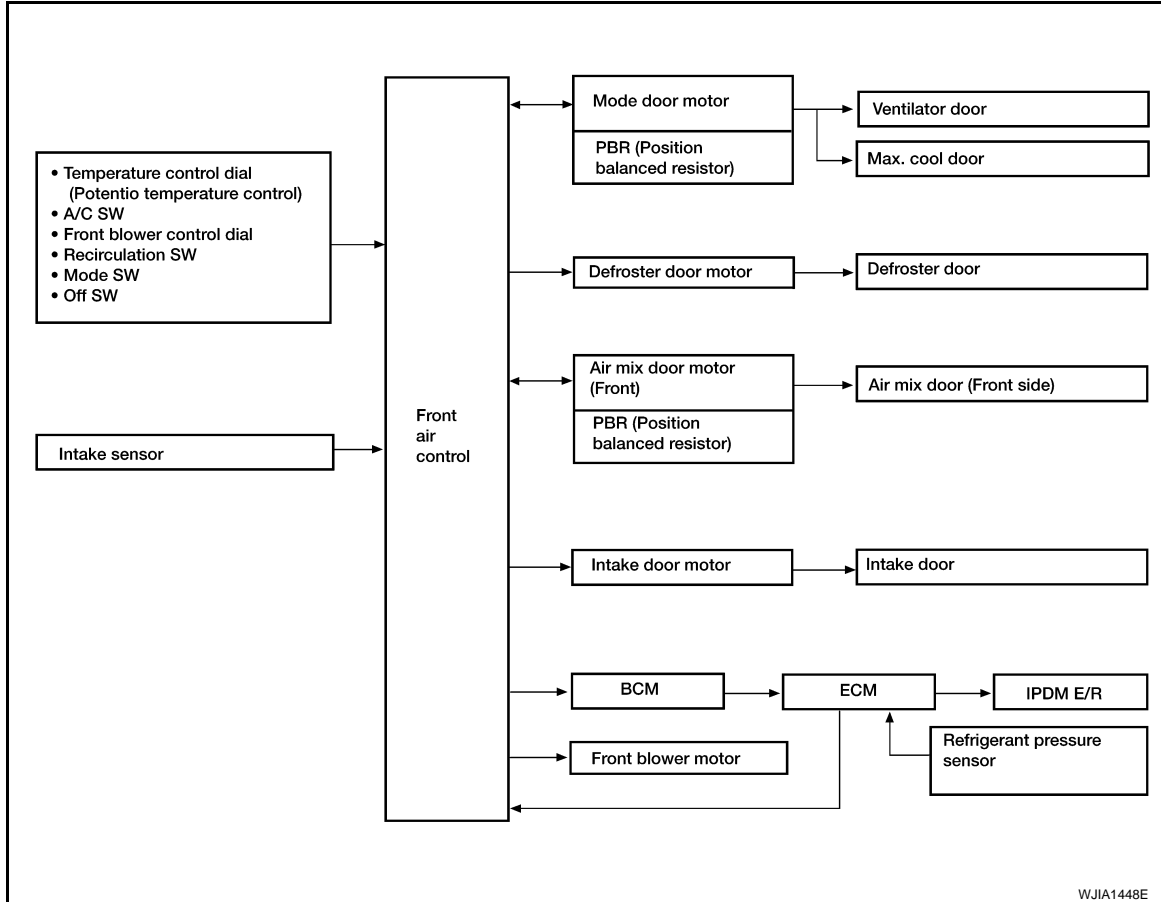

WJIA1448E

### Control System Description

INFOID:000000001669132

#### CONTROL OPERATION

##### Front air control

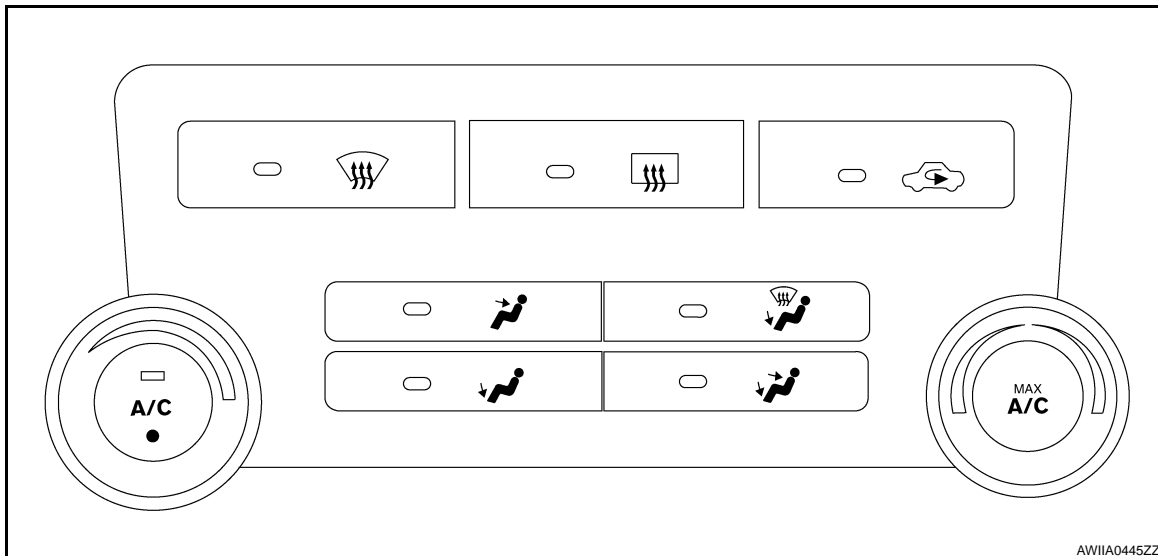

AWIIA0445ZZ

# MANUAL AIR CONDITIONER SYSTEM

< FUNCTION DIAGNOSIS >

[MANUAL A/C (TYPE 1)]

## TEMPERATURE CONTROL DIAL

Increases or decreases the set temperature.

## RECIRCULATION ( ) SWITCH

- When REC switch is ON, REC switch indicator turns ON, and air inlet is set to REC.
- When REC switch is turned OFF, or when compressor is turned from ON to OFF, REC switch is automatically turned OFF. REC mode can be re-entered by pressing REC switch again.
- REC switch is not operated when DEF switch is turned ON, at the D/F position, or in floor position.

## DEFROSTER ( ) SWITCH

Positions the air outlet doors to the defrost position. Also positions the intake doors to the outside air position, and turns A/C compressor ON.

## REAR WINDOW DEFOGGER SWITCH (IF EQUIPPED)

When switch is ON, rear window and door mirrors are defogged.

## OFF SWITCH

The compressor and blower are OFF, the intake doors are set to the outside air position, and the air outlet doors are set to the foot (75% foot and 25% defrost) position.

## BLOWER CONTROL DIAL/OFF SWITCH

- The blower speed is manually controlled with this dial.
- The compressor and blower are OFF, the intake doors are set to the outside air position, and the air outlet doors are set to the foot position.

## A/C SWITCH

The compressor is ON or OFF.

(Pressing the A/C switch when the AUTO switch is ON will turn off the A/C switch and compressor.)

## MODE SWITCHES

Controls the air discharge outlets.

## MAGNET CLUTCH CONTROL

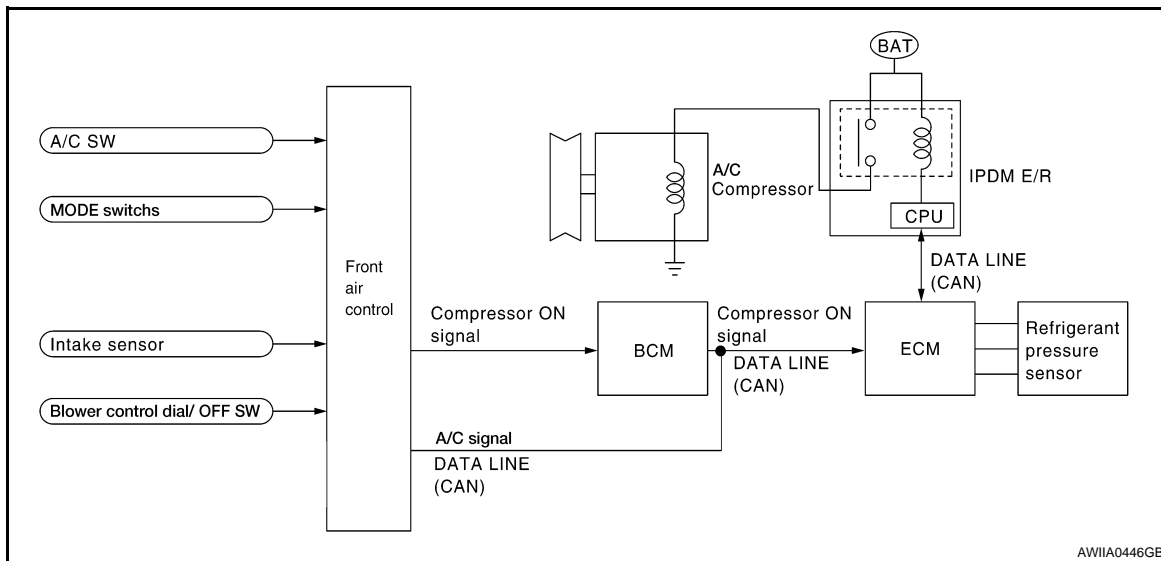

When A/C switch or DEF switch is pressed, front air control inputs compressor ON signal to BCM.

BCM sends compressor ON signal to ECM and front air control, via CAN communication line.

ECM judges whether compressor can be turned ON, based on each sensor status (refrigerant pressure sensor signal, throttle angle sensor, etc.). If it judges compressor can be turned ON, it sends compressor ON signal to IPDM E/R, via CAN communication line.

Upon receipt of compressor ON signal from ECM, IPDM E/R turns air conditioner relay ON to operate compressor.

# MANUAL AIR CONDITIONER SYSTEM

< FUNCTION DIAGNOSIS >

[MANUAL A/C (TYPE 1)]

## Discharge Air Flow

INFOID:000000001669133

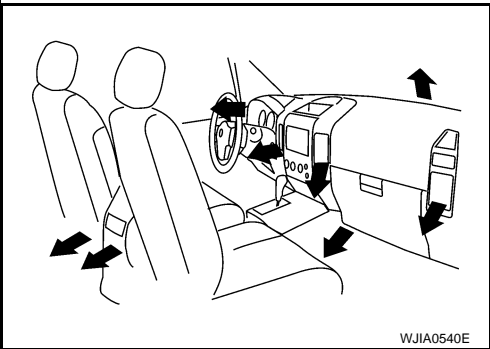
 <p style="text-align: right; font-size: small;">WJIA0540E</p>			
Mode door position	Air outlet/distribution		
	Vent	Foot	Defroster
	95%	5%	—
	60%	40%	—
	—	70%	30%
	—	60%	40%
	—	10%	90%

## Switches And Their Control Function

INFOID:000000001669134

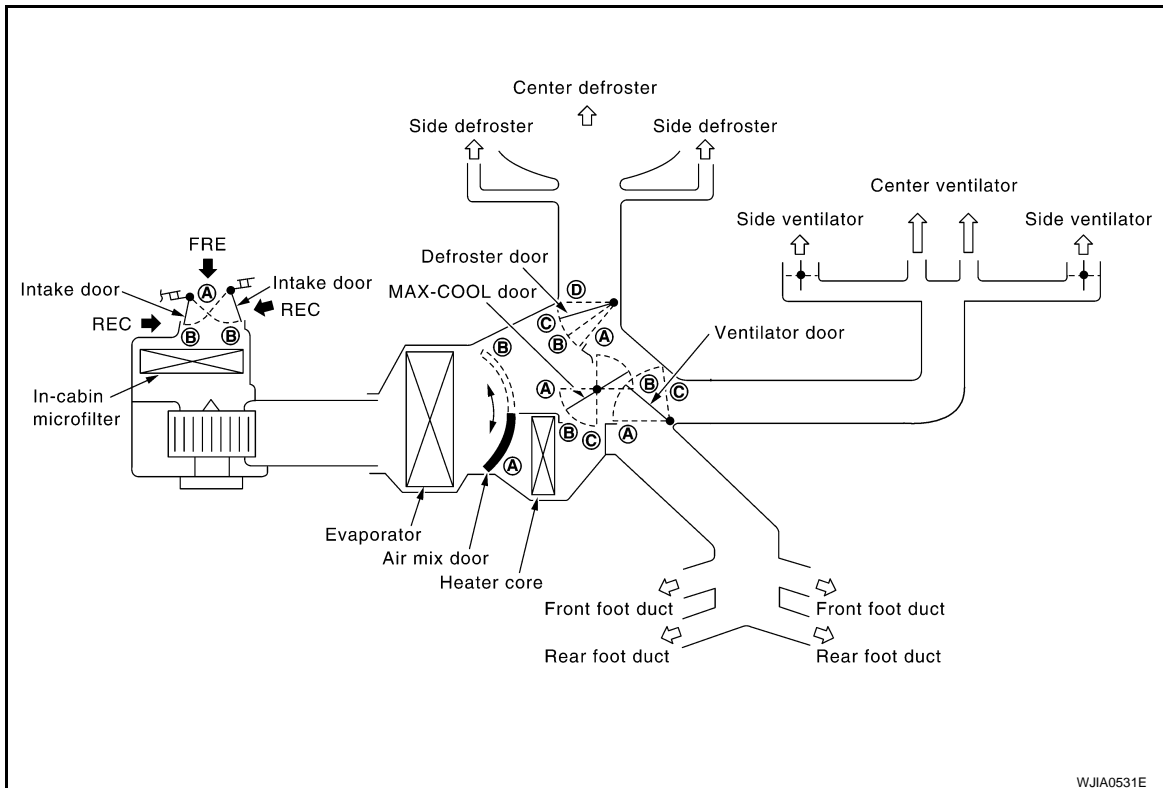

# MANUAL AIR CONDITIONER SYSTEM

< FUNCTION DIAGNOSIS >

[MANUAL A/C (TYPE 1)]

Position or switch	MODE SW				DEF SW		REC SW		Temperature switch			OFF SW
	VENT	B/L	FOOT	D/F	ON	OFF	ON	OFF				
Door					FRONT 							
Ventilator door	(A)	(B)	(C)	(C)	(C)	—	—		—			(C)
MAX-COOL door	(A)	(B)	(B)	(B)	(C)		—		—			(B)
Defroster door	(D)	(D)	(D <sub>or</sub> C)	(B)	(A)		—		—			(C)
Intake door	—				(B)		(A)	(B)	—			(B)
Air mix door	—				—		—		(A)		(B)	—

AWIA0447GB

A  
B  
C  
D  
E  
F  
G  
H  
J  
K  
L  
M  
N  
O  
P

HAC

## CAN COMMUNICATION SYSTEM

### System Description

INFOID:000000001669135

Refer to [LAN-4. "System Description"](#).



## DIAGNOSIS SYSTEM (HVAC)

### CONSULT-III Function (HVAC)

INFOID:000000001683792

CONSULT-III can display each diagnostic item using the diagnostic test modes shown following.

Diagnostic mode	Description
SELF-DIAG RESULTS	Displays Front air control self-diagnosis results.
DATA MONITOR	Displays Front air control input/output data in real time.
CAN DIAG SUPPORT MNTR	The result of transmit/receive diagnosis of CAN communication can be read.
ECU PART NUMBER	Front air control part number can be read.

### SELF-DIAGNOSIS

#### Display Item List

DTC	Description	Reference page
B2573	Battery voltage out of range	<a href="#">CHG-4, "Work Flow"</a>
B257B	Ambient sensor circuit short	<a href="#">HAC-148, "Ambient Sensor Diagnosis Procedure"</a>
B257C *1	Ambient sensor circuit open	
B2581	Intake sensor circuit short	<a href="#">HAC-151, "Intake Sensor Diagnosis Procedure"</a>
B2582	Intake sensor circuit open	
U1000	CAN bus fault	<a href="#">LAN-14, "Trouble Diagnosis Flow Chart"</a>

\*1: On models with mid audio system but without outside temperature display in combination meter, DTC will always be present.

### DATA MONITOR

#### Display Item List

Monitor item	Value	Contents
BATT VIA CAN	"V"	Displays battery voltage signal.
IGN VIA CAN	"ON/OFF"	Displays ignition switch signal.
AMB TEMP SEN	"°C"	Displays ambient sensor signal.
EVAP TEMP SEN	"°C"	Displays intake sensor signal.
MODE FDBCK	"V"	Displays mode door motor feedback signal.
DVR MIX FDBCK	"V"	Displays air mix door motor feedback signal.
DEF FDBCK	"V"	Displays defroster door motor feedback signal.
RECIRC	"ON/OFF"	Displays recirculation switch signal.
DEFROST	"ON/OFF"	Displays defroster switch signal.
A/C	"ON/OFF"	Displays A/C switch signal.
L TEMP UP	"ON/OFF"	Displays driver side temperature control dial (temp increase) signal.
L TEMP DOWN	"ON/OFF"	Displays driver side temperature control dial (temp decrease) signal.
RR DEFOG	"ON/OFF"	Displays rear defroster request signal.
FAN UP	"ON/OFF"	Displays blower motor (blower speed increase) signal.
FAN DOWN	"ON/OFF"	Displays blower motor (blower speed decrease) signal.

## DIAGNOSIS SYSTEM (BCM)

### CONSULT-III Function (BCM)

INFOID:000000001669137

CONSULT-II can display each diagnostic item using the diagnostic test modes shown following.

BCM diagnostic test item	Diagnostic mode	Description
Inspection by part	WORK SUPPORT	Supports inspections and adjustments. Commands are transmitted to the BCM for setting the status suitable for required operation, input/output signals are received from the BCM and received data is displayed.
	DATA MONITOR	Displays BCM input/output data in real time.
	ACTIVE TEST	Operation of electrical loads can be checked by sending drive signal to them.
	SELF-DIAG RESULTS	Displays BCM self-diagnosis results.
	CAN DIAG SUPPORT MNTR	The result of transmit/receive diagnosis of CAN communication can be read.
	ECU PART NUMBER	BCM part number can be read.
	CONFIGURATION	Performs BCM configuration read/write functions.

### DATA MONITOR

#### Display Item List

Monitor item name "operation or unit"	Contents
IGN ON SW "ON/OFF"	Displays "IGN Position (ON)/OFF, ACC Position (OFF)" status as judged from ignition switch signal.
COMP ON SIG "ON/OFF"	Displays "COMP (ON)/COMP (OFF)" status as judged from air conditioner switch signal.
FAN ON SIG "ON/OFF"	Displays "FAN (ON)/FAN (OFF)" status as judged from blower motor switch signal.

## SELF-DIAGNOSIS FUNCTION

### Front Air Control Self-Diagnosis

INFOID:000000001686382



#### A/C SYSTEM SELF-DIAGNOSIS FUNCTION

The self-diagnosis function is built into the front air control to quickly locate the cause of malfunctions.

#### DESCRIPTION

The self-diagnostic system diagnoses sensors, CAN system, and battery voltage on front air control. Refer to applicable sections (items) for details. Fault codes (if any are present) will be displayed in the ambient temperature display area (if equipped). Refer to [HAC-115, "Front Air Control Self-Diagnosis Code Chart"](#).

#### SELF-DIAGNOSTIC MODE

1. Rotate the blower control dial counterclockwise to the OFF position.
2. Press the FLOOR/DEF (  ) and DEF (  ) mode switches together and release on the front air control.
3. Press the REC (  ) to enter self diagnostic mode.
4. Turn ignition switch OFF to exit out of self-diagnostic mode.

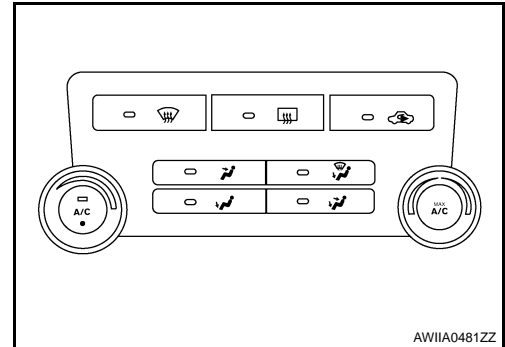

### Front Air Control Self-Diagnosis Code Chart

INFOID:000000001686383

#### SELF-DIAGNOSTIC CODE CHART

Code No.	Reference page	
03	Battery voltage out of range	<a href="#">CHG-4, "Work Flow"</a>
40	Ambient sensor circuit short	<a href="#">HAC-60, "Ambient Sensor Diagnosis Procedure"</a>
41	Ambient sensor circuit open	
56	Intake sensor circuit short	<a href="#">HAC-68, "Intake Sensor Diagnosis Procedure"</a>
57	Intake sensor circuit open	
80	CAN bus fault	<a href="#">LAN-14, "Trouble Diagnosis Flow Chart"</a>
90	Stuck button	<a href="#">VTL-8, "Removal and Installation"</a>

# MANUAL A/C IDENTIFICATION TABLE

< COMPONENT DIAGNOSIS >

[MANUAL A/C (TYPE 1)]

## COMPONENT DIAGNOSIS

### MANUAL A/C IDENTIFICATION TABLE

#### Application Table

INFOID:000000001678221

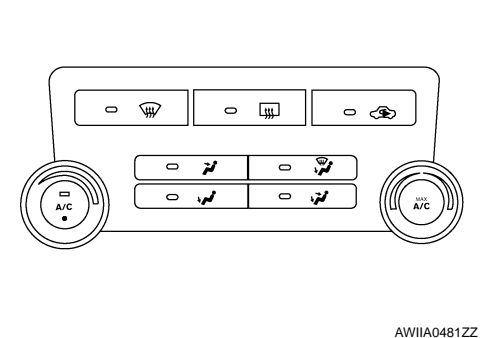
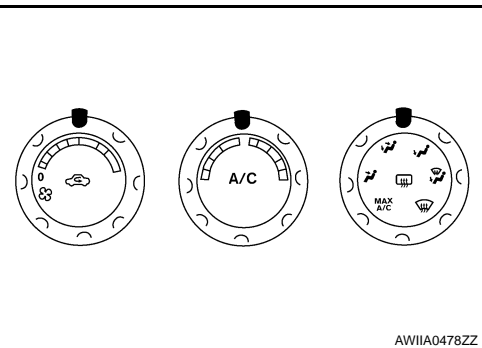
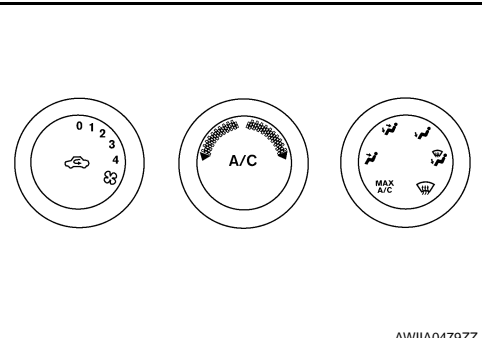
Manual A/C Type	Description	Visual Identification
Manual A/C (Type 1)	Two Control Dial System	 <p style="text-align: right;">AWIIA0481ZZ</p>
Manual A/C (Type 2)	Three Control Dial System [with variable blower control (VBC)]	 <p style="text-align: right;">AWIIA0478ZZ</p>
Manual A/C (Type 3)	Three Control Dial System [without variable blower control (VBC)]	 <p style="text-align: right;">AWIIA0479ZZ</p>

## MODE DOOR MOTOR

### System Description

INFOID:000000001669141

### SYSTEM DESCRIPTION

#### Component Parts

Mode door control system components are:

- Front air control
- Mode door motor
- PBR (built into mode door motor)
- Intake sensor

#### System Operation

The mode door position (vent, B/L, foot, D/F, and defrost) is set by the front air control by means of the mode door motor. When a mode door position is selected on the front air control, voltage is applied to one circuit of the mode door motor while ground is applied to the other circuit, causing the mode door motor to rotate. The direction of rotation is determined by which circuit has voltage applied to it, and which one has ground applied to it. The front air control monitors the mode door position by measuring the voltage signal on the PBR circuit.

### COMPONENT DESCRIPTION

#### Mode Door Motor

The mode door motor is attached to the heater & cooling unit assembly. It rotates so that air is discharged from the outlet as indicated by the front air control. Motor rotation is conveyed to a link which activates the mode door.

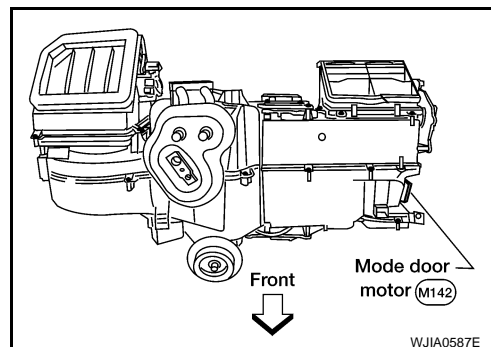

### Mode Door Motor Component Function Check



INFOID:000000001669142

#### INSPECTION FLOW

#### 1. CONFIRM SYMPTOM BY PERFORMING OPERATIONAL CHECK - DISCHARGE AIR

1. Press each mode switch and press the  (DEF) switch. Each position indicator should illuminate.
2. Confirm that discharge air comes out according to the air distribution table. Refer to [HAC-110, "Discharge Air Flow"](#).

**NOTE:**

Confirm that the compressor clutch is engaged (visual inspection) and intake door position is at FRESH  when DEF () or D/F () is selected.

Can a symptom be duplicated?

- YES >> GO TO 3.  
NO >> GO TO 2.

#### 2. PERFORM COMPLETE OPERATIONAL CHECK

Perform a complete operational check and check for any symptoms. Refer to [HAC-101, "Operational Check"](#).

Can a symptom be duplicated?

- YES >> Refer to [HAC-100, "How to Perform Trouble Diagnosis For Quick And Accurate Repair"](#).  
NO >> System OK.

#### 3. CHECK FOR SERVICE BULLETINS

Check for any service bulletins.

# MODE DOOR MOTOR

[MANUAL A/C (TYPE 1)]

## < COMPONENT DIAGNOSIS >

>> GO TO 4.

### 4. CHECK MODE DOOR OPERATION

Check and verify mode door mechanism for smooth operation in each mode.

Is the inspection result normal?

YES >> GO TO 5.

NO >> Repair as necessary.

### 5. CHECK THE MODE DOOR MOTOR PBR CIRCUIT

Perform diagnostic procedure for the mode door motor. Refer to [HAC-117, "Mode Door Motor Component Function Check"](#).

Is the inspection result normal?

YES >> GO TO 6.

NO >> Repair PBR circuit or replace motor. Refer to [HAC-118, "Mode Door Motor Diagnosis Procedure"](#).

### 6. RECHECK FOR SYMPTOMS

Perform a complete operational check and check for any symptoms. Refer to [HAC-101, "Operational Check"](#).

Does another symptom exist?

YES >> Repair as necessary.

NO >> Replace front air control Refer to [VTL-8, "Removal and Installation"](#).

## Mode Door Motor Diagnosis Procedure

INFOID:000000001669143

SYMPTOM:

- Air outlet does not change.
- Mode door motor does not operate normally.

### 1. CHECK FRONT AIR CONTROL FOR POWER AND GROUND

1. Turn ignition switch ON.
2. Press the B/L (↺) mode switch.
3. Check voltage between front air control harness connector M49 terminal 19 and terminal 20 while pressing the mode switch to the floor (↵) mode.

Connector	Terminals		Condition	Voltage (Approx.)
	(+)	(-)		
Front air control: M49	20	19	Press mode switch	Battery voltage

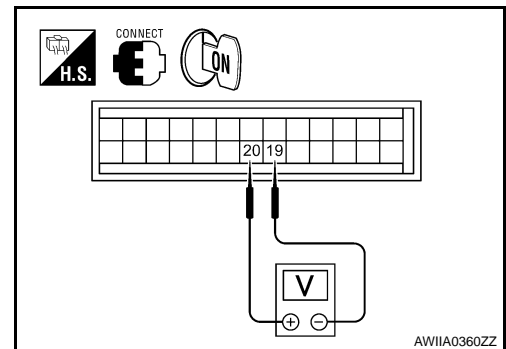

Is the inspection result normal?

YES >> GO TO 4.

NO >> GO TO 3.

### 2. CHECK MODE DOOR MOTOR CIRCUITS FOR SHORT TO GROUND

1. Turn ignition switch OFF.
2. Disconnect the front air control harness connector.
3. Check continuity between front air control harness connector M49 terminal 19, 20 and ground.

**19 - Ground : Continuity should not exist.**

**20 - Ground : Continuity should not exist.**

Is the inspection result normal?

YES >> Replace front air control. Refer to [VTL-8, "Removal and Installation"](#).

NO >> Repair or replace harness as necessary.

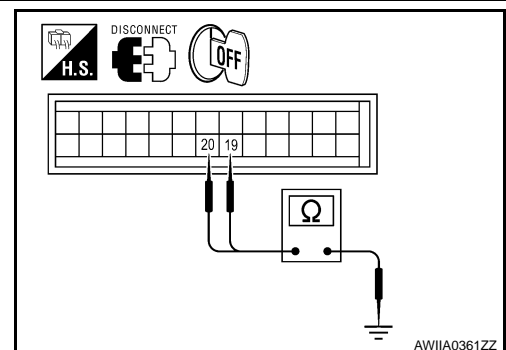

# MODE DOOR MOTOR

< COMPONENT DIAGNOSIS >

[MANUAL A/C (TYPE 1)]

## 3. CHECK FRONT AIR CONTROL FOR GROUND AND POWER

1. Press the mode switch to the D/F (D/F) mode.
2. Check voltage between front air control harness connector M49 terminal 19 and terminal 20 while pressing the mode switch to the vent (V) mode.

Connector	Terminals		Condition	Voltage (Approx.)
	(+)	(-)		
Front air control: M49	19	20	Press mode switch	Battery voltage

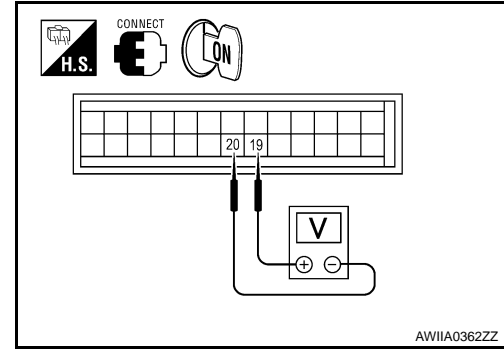

Is the inspection result normal?

YES >> GO TO 5.

NO >> Replace front air control. Refer to [VTL-8. "Removal and Installation"](#).

## 4. CHECK MODE DOOR MOTOR AND CIRCUITS FOR OPEN

1. Turn ignition switch OFF.
2. Disconnect the front air control harness connector.
3. Check continuity between front air control harness connector M49 terminal 19 and terminal 20.

**Continuity should exist.**

Is the inspection result normal?

YES >> GO TO 7.

NO >> GO TO 6.

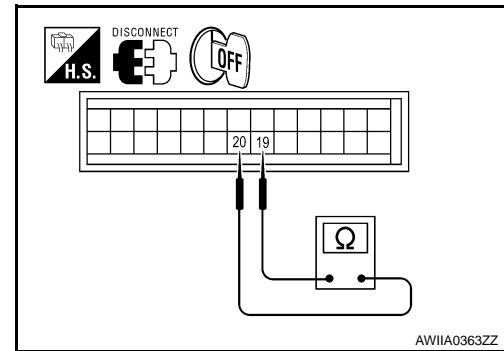

## 5. CHECK MODE DOOR MOTOR CIRCUITS FOR OPEN

1. Disconnect the mode door motor harness connector.
2. Check continuity between front air control harness connector M49 (A) terminal 19, 20 and the mode door motor harness connector M142 (B) terminal 5, 6.

**5 - 19 : Continuity should exist.**

**6 - 20 : Continuity should exist.**

Is the inspection result normal?

YES >> Replace mode door motor. Refer to [VTL-19. "Removal and Installation"](#).

NO >> Repair or replace harness as necessary.

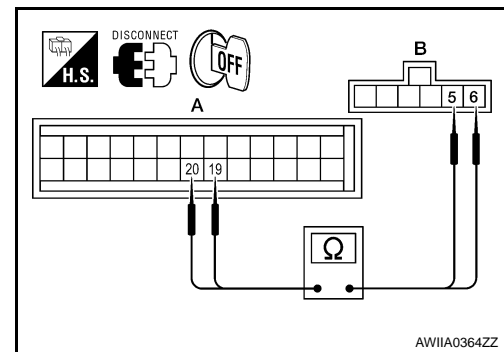

## 6. CHECK FRONT AIR CONTROL FOR PBR POWER AND GROUND

1. Reconnect front air control harness connector.
2. Turn ignition switch ON.
3. Check voltage between front air control harness connector M50 (A) terminal 28 and M49 (B) terminal 3.

Connector	Terminals		Voltage (Approx.)
	(+)	(-)	
Front air control: M49, M50	28	3	5V

Is the inspection result normal?

YES >> GO TO 9.

NO >> GO TO 8.

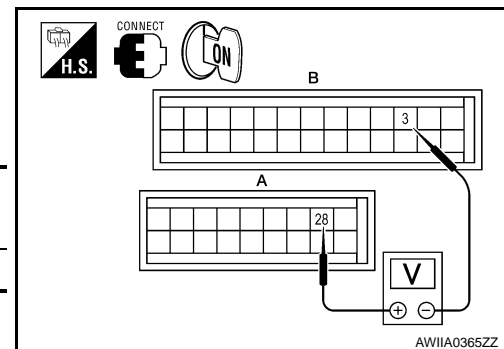

## 7. CHECK PBR REFERENCE VOLTAGE CIRCUIT FOR SHORT TO GROUND

# MODE DOOR MOTOR

[MANUAL A/C (TYPE 1)]

## < COMPONENT DIAGNOSIS >

1. Turn ignition switch OFF.
2. Disconnect the front air control harness connector.
3. Check continuity between front air control harness connector M50 terminal 28 and ground.

**Continuity should not exist.**

Is the inspection result normal?

- YES >> Replace front air control Refer to [VTL-8, "Removal and Installation"](#).
- NO >> Repair or replace harness as necessary.

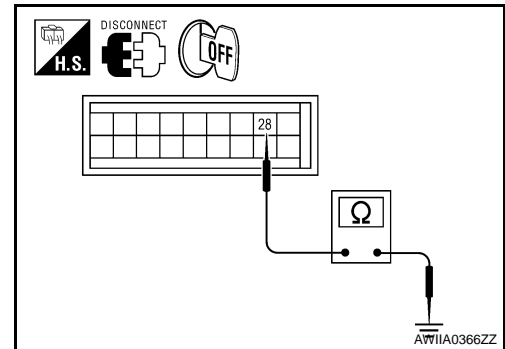

## 8. CHECK PBR REFERENCE VOLTAGE AND GROUND CIRCUITS

1. Turn ignition switch OFF.
2. Disconnect the front air control harness connector.
3. Check continuity between front air control harness connector M50 (A) terminal 28 and M49 (B) terminal 3.

**Continuity should exist.**

Is the inspection result normal?

- YES >> GO TO 11.
- NO >> GO TO 10

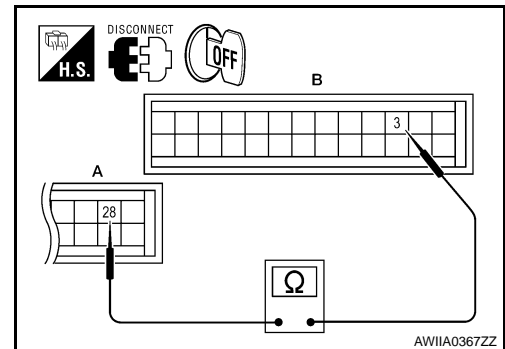

## 9. CHECK PBR REFERENCE VOLTAGE CIRCUIT FOR OPEN

1. Disconnect the mode door motor harness connector.
2. Check continuity between mode door motor harness connector M142 (B) terminal 3, 1 and front air control harness connector M49 (C) terminal 3, M50 (A) terminal 28.

**28 - 1 : Continuity should exist.**

**3 - 3 : Continuity should exist.**

Is the inspection result normal?

- YES >> Replace mode door motor. Refer to [VTL-19, "Removal and Installation"](#).
- NO >> Repair or replace harness as necessary.

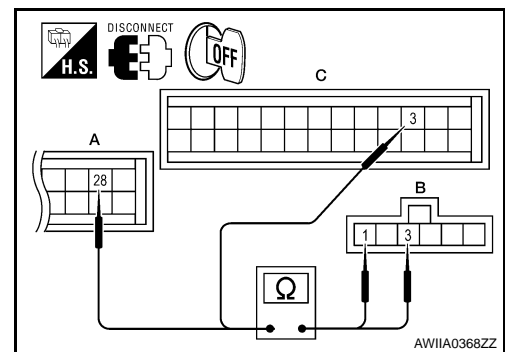

## 10. CHECK PBR FEEDBACK VOLTAGE

1. Reconnect the front air control harness connector.
2. Turn ignition switch ON.
3. Check voltage between front air control harness connector M49 terminal 7 and ground while cycling mode switch through all modes.

**Voltage : Approx. 1V - 4.5V**

Is the inspection result normal?

- YES >> GO TO 13.
- NO >> GO TO 12.

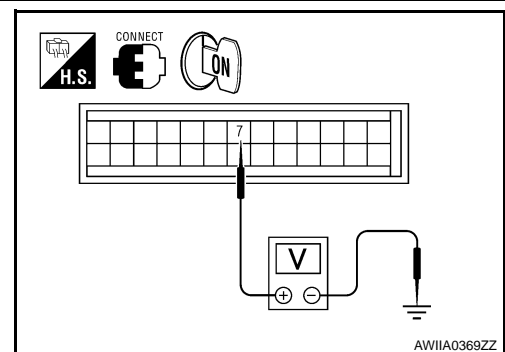

## 11. CHECK PBR FEEDBACK SIGNAL CIRCUIT FOR SHORT TO GROUND



# MODE DOOR MOTOR

## < COMPONENT DIAGNOSIS >

[MANUAL A/C (TYPE 1)]

1. Turn ignition switch OFF.
2. Disconnect front air control harness connector.
3. Check continuity between front air control harness connector M49 terminal 7 and ground.

**Continuity should not exist.**

Is the inspection result normal?

- YES >> Replace front air control Refer to [VTL-8, "Removal and Installation"](#).
- NO >> Repair or replace harness as necessary.

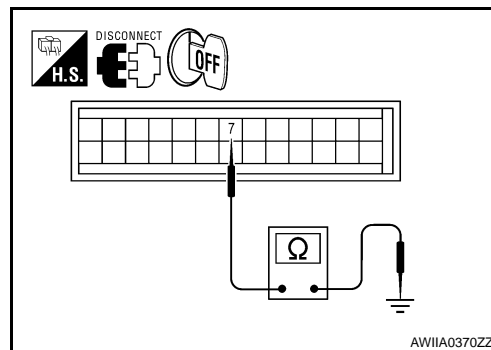

## 12. CHECK PBR FEEDBACK CIRCUIT FOR OPEN

1. Turn ignition switch OFF.
2. Disconnect the mode door motor harness connector and front air control harness connector.
3. Check continuity between mode door motor harness connector M142 terminal 2 and front air control harness connector M49 terminal 7.

**Continuity should exist.**

Is the inspection result normal?

- YES >> Replace mode door motor. Refer to [VTL-19, "Removal and Installation"](#).
- NO >> Repair or replace harness as necessary.

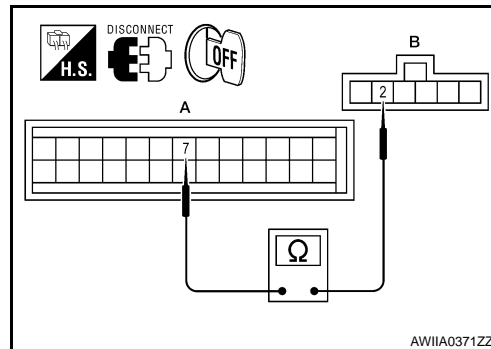

A  
B  
C  
D  
E  
F  
G  
H  
J  
K  
L  
M  
N  
O  
P

HAC

## AIR MIX DOOR MOTOR

### System Description

INFOID:000000001669144

### SYSTEM DESCRIPTION

**SYMPTOM:**

- Discharge air temperature does not change.
- Air mix door motor does not operate.

### SYSTEM DESCRIPTION

#### Component Parts

Air mix door control system components are:

- Front air control
- Air mix door motor
- PBR (built-into air mix door motors)
- Intake sensor

#### System Operation

The front air control receives data from the temperature selected by the driver side, passenger side, and rear. The front air control then applies a voltage to one circuit of the appropriate air mix door motor, while ground is applied to the other circuit, causing the appropriate air mix door motor to rotate. The direction of rotation is determined by which circuit has voltage applied to it, and which one has ground applied to it. The front air control monitors the air mix door positions by measuring the voltage signal on the PBR circuits of each door.

#### Air Mix Door Control Specification

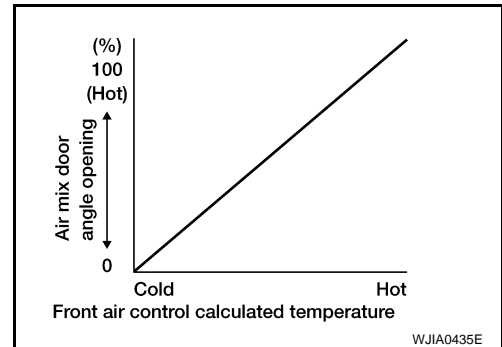

### COMPONENT DESCRIPTION

#### Air Mix Door Motors

The air mix door motor is attached to the front heater & cooling unit assembly. The motor rotates so that the air mix door is opened or closed to a position set by the front air control. Motor rotation is then conveyed through a shaft and the air mix door position is then fed back to the front air control by the PBR built into the air mix door motor.

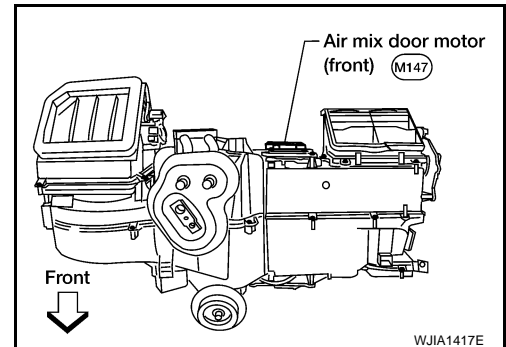

### Air Mix Door Motor Component Function Check

INFOID:000000001669145

### INSPECTION FLOW

#### 1. CONFIRM SYMPTOM BY PERFORMING OPERATIONAL CHECK - TEMPERATURE INCREASE

1. Turn the temperature control dial clockwise to maximum hot.
2. Check for hot air at discharge air outlets.

>> GO TO 2.

## 2. CONFIRM SYMPTOM BY PERFORMING OPERATIONAL CHECK - TEMPERATURE DECREASE

1. Turn the temperature control dial counterclockwise to maximum cold.
2. Check for cold air at discharge air outlets.

Can a symptom be duplicated?

- YES >> GO TO 4.  
 NO >> GO TO 3.

## 3. PERFORM COMPLETE OPERATIONAL CHECK

Perform a complete operational check and check for any symptoms. Refer to [HAC-101, "Operational Check"](#).

Can a symptom be duplicated?

- YES >> Refer to [HAC-100, "How to Perform Trouble Diagnosis For Quick And Accurate Repair"](#).  
 NO >> System OK.

## 4. CHECK FOR SERVICE BULLETINS

Check for any service bulletins.

>> GO TO 5.

## 5. CHECK AIR MIX DOOR OPERATION

Check and verify air mix door mechanism for smooth operation from maximum cold °to maximum hot in each mode.

Is the inspection result normal?

- YES >> GO TO 6.  
 NO >> Repair as necessary.

## 6. CHECK THE AIR MIX DOOR MOTOR PBR CIRCUIT

Perform diagnostic procedure for the air mix door motor. Refer to [HAC-122, "Air Mix Door Motor Component Function Check"](#).

Is the inspection result normal?

- YES >> GO TO 7.  
 NO >> Repair PBR circuit or replace air mix door motor. Refer to [VTL-20, "Removal and Installation"](#).

## 7. RECHECK FOR ANY SYMPTOMS

Perform a complete operational check for any symptoms. Refer to [HAC-101, "Operational Check"](#).

Does another symptom exist?

- YES >> Refer to [HAC-100, "How to Perform Trouble Diagnosis For Quick And Accurate Repair"](#).  
 NO >> Replace front air control Refer to [VTL-8, "Removal and Installation"](#).

## Air Mix Door Motor Diagnosis Procedure

INFOID:000000001669146

SYMPTOM:

- Discharge air temperature does not change.
- Air mix door motor does not operate.

### DIAGNOSTIC PROCEDURE FOR AIR MIX DOOR MOTOR

#### 1. CHECK FRONT AIR CONTROL FOR POWER AND GROUND

# AIR MIX DOOR MOTOR

## < COMPONENT DIAGNOSIS >

[MANUAL A/C (TYPE 1)]

1. Turn ignition switch ON.
2. Rotate temperature control dial to maximum hot.
3. Check voltage between front air control harness connector M49 terminal 17 and terminal 18 while rotating temperature control dial to maximum cold.

Connector	Terminals		Condition	Voltage (Approx.)
	(+)	(-)		
Front air control: M49	17	18	Rotate temp control dial	Battery voltage

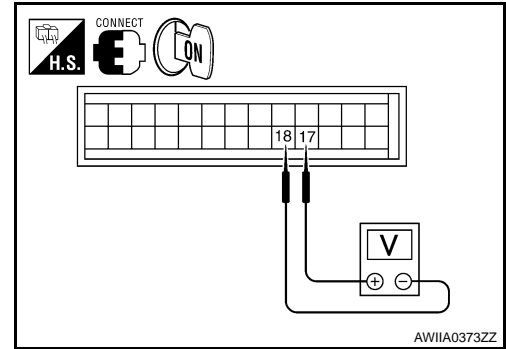

Is the inspection result normal?

- YES >> GO TO 4.  
NO >> GO TO 3.

## 2. CHECK AIR MIX DOOR MOTOR CIRCUITS FOR SHORT TO GROUND

1. Turn ignition switch OFF.
2. Disconnect the front air control harness connector.
3. Check continuity between front air control harness connector M49 terminal 17, 18 and ground.

**17 - Ground : Continuity should not exist.**  
**18 - Ground : Continuity should not exist.**

Is the inspection result normal?

- YES >> Replace front air control. Refer to [VTL-8. "Removal and Installation"](#).  
NO >> Repair or replace harness as necessary.

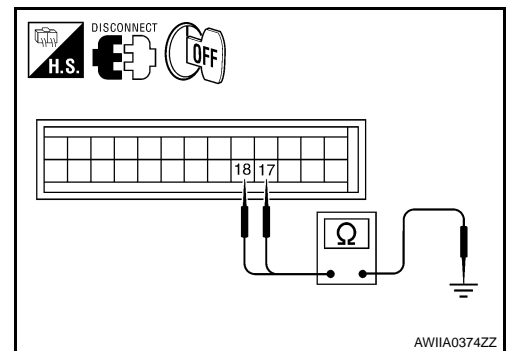

## 3. CHECK FRONT AIR CONTROL FOR POWER AND GROUND

1. Turn ignition switch ON.
2. Rotate temperature control dial to maximum hot.
3. Check voltage between front air control harness connector M49 terminal 17 and terminal 18 while rotating temperature control dial to maximum cold.

Connector	Terminals		Condition	Voltage (Approx.)
	(+)	(-)		
Front air control: M49	18	17	Rotate temp control dial	Battery voltage

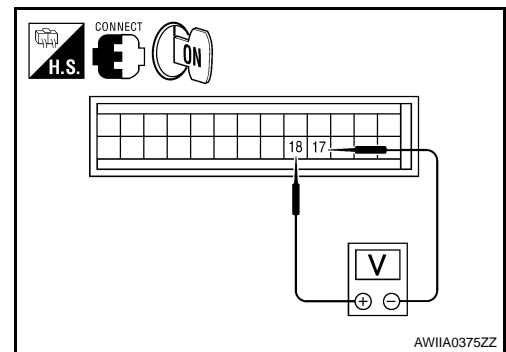

Is the inspection result normal?

- YES >> GO TO 5.  
NO >> Replace front air control. Refer to [VTL-8. "Removal and Installation"](#).

## 4. CHECK AIR MIX DOOR MOTOR CIRCUITS FOR OPEN

1. Turn ignition switch OFF.
2. Disconnect the front air control harness connector.
3. Check continuity between front air control harness connector M49 terminal 17 and terminal 18.

**Continuity should exist.**

Is the inspection result normal?

- YES >> GO TO 7.  
NO >> GO TO 6.

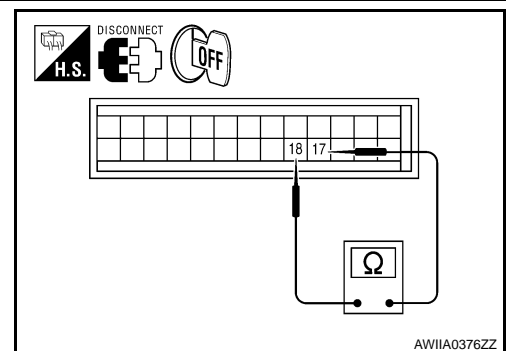

## 5. CHECK AIR MIX DOOR MOTOR CIRCUITS FOR OPEN

# AIR MIX DOOR MOTOR

[MANUAL A/C (TYPE 1)]

## < COMPONENT DIAGNOSIS >

1. Disconnect the air mix door motor harness connector.
2. Check continuity between front air control harness connector M49 (A) terminal 17, 18 and the air mix door motor harness connector M147 (B) terminal 1, 6.

**17 - 1 : Continuity should exist.**

**18 - 6 : Continuity should exist.**

Is the inspection result normal?

YES >> Replace air mix door motor. Refer to [VTL-20. "Removal and Installation"](#).

NO >> Repair or replace harness as necessary.

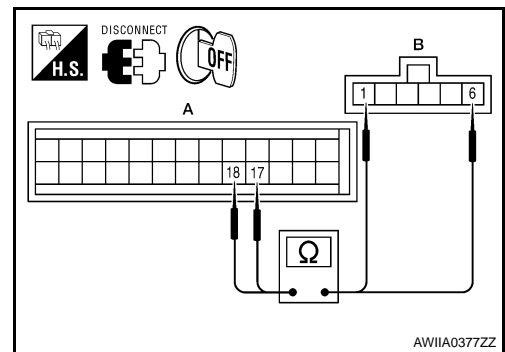

## 6. CHECK FRONT AIR CONTROL FOR PBR POWER AND GROUND

1. Reconnect front air control harness connector.
2. Turn ignition switch ON.
3. Check voltage between front air control harness connector M50 (A) terminal 28 and M49 (B) terminal 3.

Connector	Terminals		Voltage (Approx.)
	(+)	(-)	
Front air control: M50, M49	28	3	5V

Is the inspection result normal?

YES >> GO TO 9.

NO >> GO TO 8.

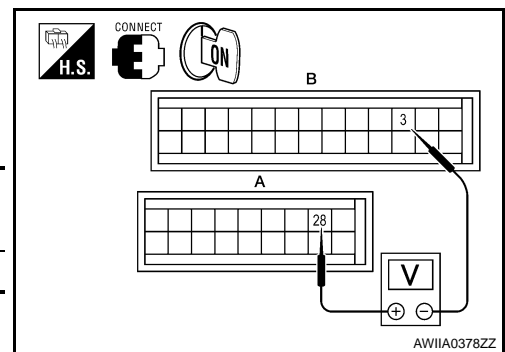

## 7. CHECK PBR REFERENCE VOLTAGE CIRCUIT FOR SHORT TO GROUND

1. Turn ignition switch OFF.
2. Disconnect the front air control harness connector.
3. Check continuity between front air control harness connector M50 terminal 28 and ground.

**Continuity should not exist.**

Is the inspection result normal?

YES >> Replace front air control. Refer to [VTL-8. "Removal and Installation"](#).

NO >> Repair or replace harness as necessary.

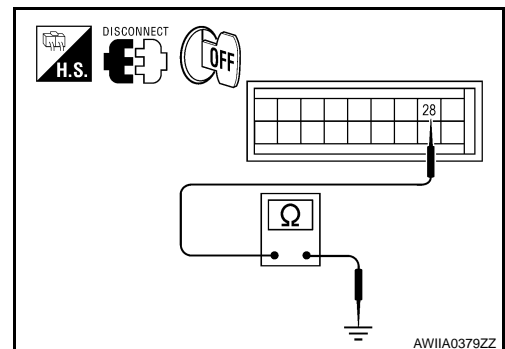

## 8. CHECK PBR REFERENCE VOLTAGE AND GROUND CIRCUITS

1. Turn ignition switch OFF.
2. Disconnect the front air control harness connector.
3. Check continuity between front air control harness connector M50 (A) terminal 28 and M49 (B) terminal 3.

**Continuity should exist.**

Is the inspection result normal?

YES >> GO TO 11.

NO >> GO TO 10.

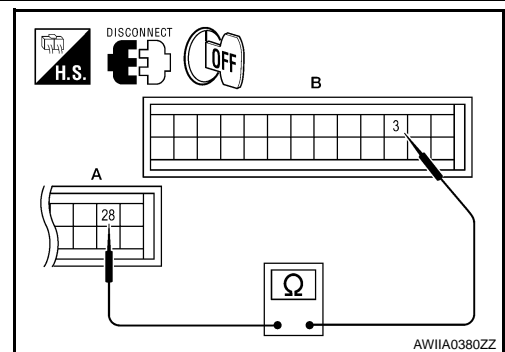

## 9. CHECK PBR REFERENCE VOLTAGE CIRCUIT FOR OPEN

# AIR MIX DOOR MOTOR

## < COMPONENT DIAGNOSIS >

[MANUAL A/C (TYPE 1)]

1. Disconnect the air mix door motor harness connector.
2. Check continuity between air mix door motor harness connector M147 (B) terminal 3, 2 and front air control harness connector M49 (C) terminal 3 and M50 (A) terminal 28.

**28 - 3 : Continuity should exist.**

**3 - 2 : Continuity should exist.**

Is the inspection result normal?

YES >> Replace air mix door motor. Refer to [VTL-20, "Removal and Installation"](#).

NO >> Repair or replace harness as necessary.

## 10. CHECK PBR FEEDBACK VOLTAGE

1. Reconnect the front air control harness connector.
2. Turn ignition switch ON.
3. Check voltage between front air control harness connector M49 terminal 6 and ground while rotating temperature control dial from maximum hot to maximum cold.

**Voltage : Approx. .5V - 4.5V**

Is the inspection result normal?

YES >> GO TO 13.

NO >> GO TO 12.

## 11. CHECK PBR FEEDBACK SIGNAL CIRCUIT FOR SHORT TO GROUND

1. Turn ignition switch OFF.
2. Disconnect front air control harness connector.
3. Check continuity between front air control harness connector M49 terminal 6 and ground.

**Continuity should not exist.**

Is the inspection result normal?

YES >> Replace front air control. Refer to [VTL-8, "Removal and Installation"](#).

NO >> Repair or replace harness as necessary.

## 12. CHECK PBR FEEDBACK CIRCUIT FOR OPEN

1. Turn ignition switch OFF.
2. Disconnect the air mix door motor harness connector and front air control harness connector.
3. Check continuity between air mix door motor harness connector M147 (B) terminal 4 and front air control harness connector M49 (A) terminal 6.

**Continuity should exist.**

Is the inspection result normal?

YES >> Replace air mix door motor. Refer to [VTL-20, "Removal and Installation"](#).

NO >> Repair or replace harness as necessary.

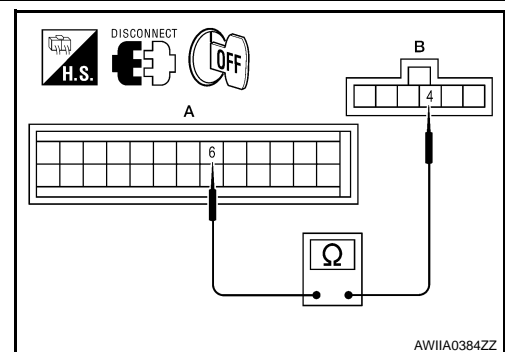
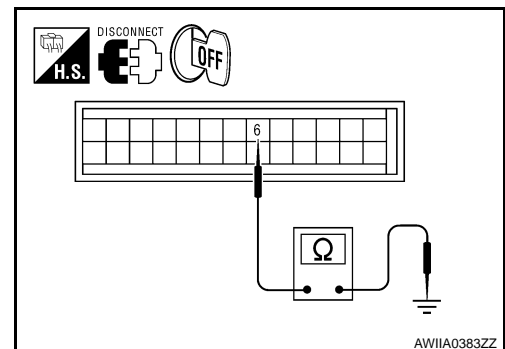
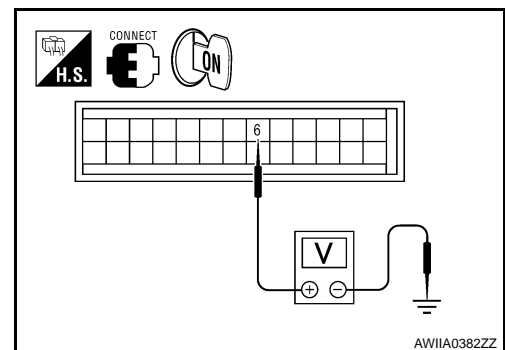
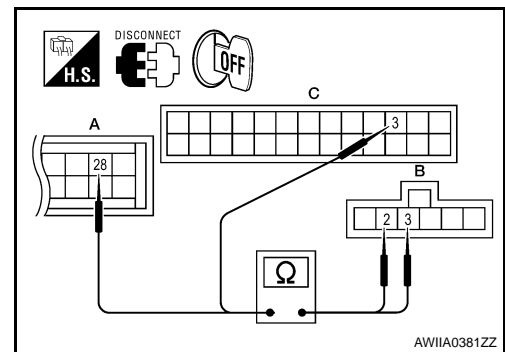

## INTAKE DOOR MOTOR

### System Description

INFOID:000000001669148

### SYSTEM DESCRIPTION

#### SYMPTOM:

- Intake door motor does not operate normally.
- Intake door does not change.

### SYSTEM DESCRIPTION

#### Component Parts

Intake door control system components are:

- Front air control
- Intake door motor (PRB built into the intake door motor)
- Ambient sensor
- Intake sensor

#### System Operation

The intake door control determines the intake door position based on the position of the recirculation switch. When the recirculation switch is depressed the intake door motor rotates closing off the fresh air inlet and recirculating the cabin air. If the recirculation switch is depressed again, the intake door motor rotates in the opposite direction, again allowing fresh air into the cabin.

#### Intake Door Control Specification

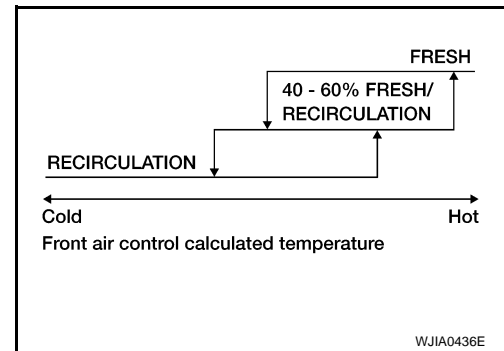

### COMPONENT DESCRIPTION

#### Intake door motor

The intake door motor is attached to the intake unit. It rotates so that air is drawn from inlets set by the front air control. Motor rotation is conveyed to a lever which activates the intake door.

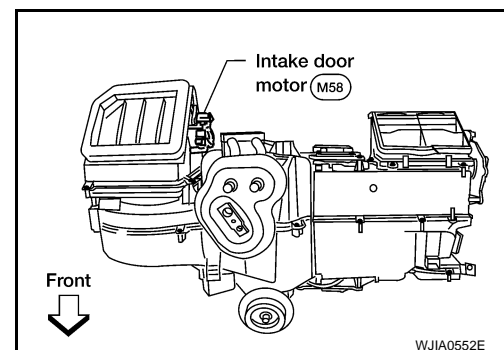





### Intake Door Motor Component Function Check

INFOID:000000001669149

#### INSPECTION FLOW

#### 1. CONFIRM SYMPTOM BY PERFORMING OPERATIONAL CHECK - REC ( )

1. Press the vent mode switch (  ).
2. Press REC (  ) switch. The REC (  ) indicator should illuminate.
3. Press REC (  ) switch again. The REC (  ) indicator should go out.
4. Listen for intake door position change (you should hear blower sound change slightly).

# INTAKE DOOR MOTOR

< COMPONENT DIAGNOSIS >

[MANUAL A/C (TYPE 1)]

Can a symptom be duplicated?

- YES >> GO TO 3.
- NO >> GO TO 2.

## 2.PERFORM COMPLETE OPERATIONAL CHECK

Perform a complete operational check and check for any symptoms. Refer to [HAC-101, "Operational Check"](#).

Can a symptom be duplicated?

- YES >> Refer to [HAC-100, "How to Perform Trouble Diagnosis For Quick And Accurate Repair"](#).
- NO >> System OK.

## 3.CHECK FOR SERVICE BULLETINS

Check for any service bulletins.

>> GO TO 4.

## 4.CHECK INTAKE DOOR OPERATION

Check and verify intake door mechanism for smooth operation.

Is the inspection result normal?

- YES >> GO TO 5.
- NO >> Repair intake door mechanism.

## 5.RECHECK FOR ANY SYMPTOMS

Perform a complete operational check for any symptoms. Refer to [HAC-101, "Operational Check"](#).

Does another symptom exist?

- YES >> Refer to [HAC-100, "How to Perform Trouble Diagnosis For Quick And Accurate Repair"](#).
- NO >> Replace front air control. Refer to [VTL-8, "Removal and Installation"](#).

## Intake Door Motor Diagnosis Procedure

INFOID:000000001669150

SYMPTOM:

- Intake door does not change.
- Intake door motor does not operate normally.

## DIAGNOSTIC PROCEDURE FOR INTAKE DOOR MOTOR

### 1.CHECK FRONT AIR CONTROL FOR POWER AND GROUND

1. Turn ignition switch ON.
2. Check voltage between front air control harness connector M49 terminal 21 and terminal 22 while placing the HVAC system into self-diagnostic mode.

Connector	Terminals		Condition	Voltage (Approx.)
	(+)	(-)		
front air control: M49	21	22	Self-diagnostic mode	Battery voltage

Is the inspection result normal?

- OK >> GO TO 4.
- NO >> GO TO 3.

### 2.CHECK INTAKE DOOR MOTOR CIRCUITS FOR SHORT TO GROUND

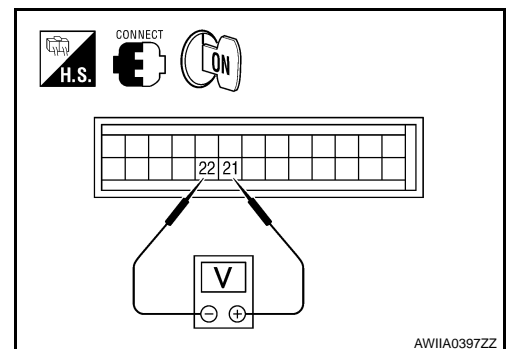



# INTAKE DOOR MOTOR

[MANUAL A/C (TYPE 1)]

## < COMPONENT DIAGNOSIS >

1. Turn ignition switch OFF.
2. Disconnect the front air control harness connector.
3. Check continuity between front air control harness connector M49 terminal 21, 22 and ground.

**21 - Ground : Continuity should not exist.**  
**22 - Ground : Continuity should not exist.**

Is the inspection result normal?

- OK >> Replace front air control. Refer to [VTL-8, "Removal and Installation"](#).  
 NO >> Repair or replace harness as necessary.

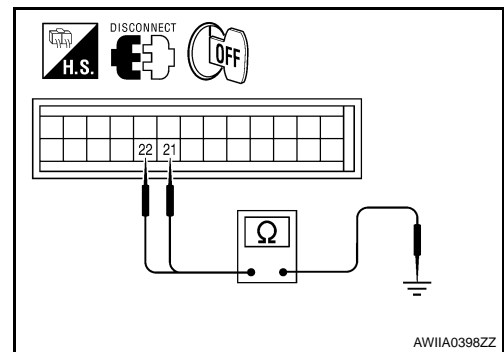

## 3. CHECK FRONT AIR CONTROL FOR GROUND AND POWER

1. Press the BACK button to back out of self-diagnostic mode.
2. Check voltage between front air control harness connector M49 terminal 21 and terminal 22 while placing the HVAC system into self-diagnostic mode.

Connector	Terminals		Condition	Voltage (Approx.)
	(+)	(-)		
front air control: M49	22	21	Self-diagnostic mode	Battery voltage

Is the inspection result normal?

- OK >> GO TO 5.  
 NO >> Replace front air control. Refer to [VTL-8, "Removal and Installation"](#).

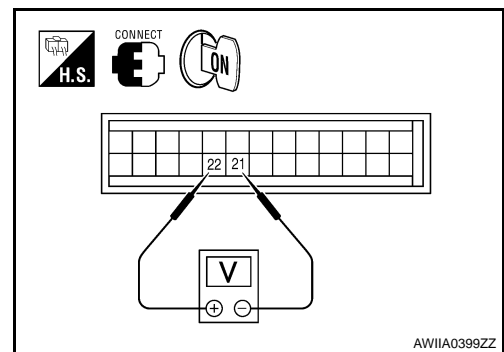

## 4. CHECK INTAKE DOOR MOTOR AND CIRCUITS FOR OPEN

1. Turn ignition switch OFF.
2. Disconnect the front air control harness connector.
3. Check continuity between front air control harness connector M49 terminal 21 and terminal 22.

**Continuity should exist.**

Is the inspection result normal?

- OK >> Replace intake door motor. Refer to [VTL-11, "Removal and Installation"](#).  
 NO >> GO TO 6.

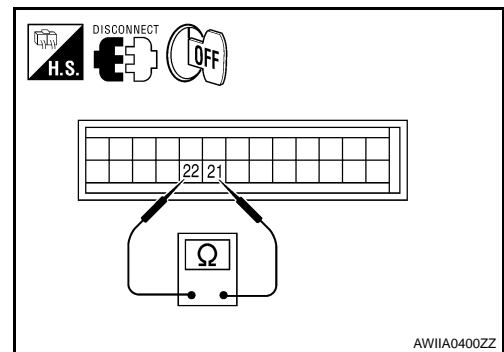

## 5. CHECK INTAKE DOOR MOTOR CIRCUITS FOR OPEN

1. Disconnect the intake door motor harness connector.
2. Check continuity between front air control harness connector M49 (A) terminal 21, 22 and the intake door motor harness connector M58 (B) terminal 1, 6.

**21 - 6 : Continuity should exist.**  
**22 - 1 : Continuity should exist.**

Is the inspection result normal?

- YES >> Replace intake door motor. Refer to [VTL-11, "Removal and Installation"](#).  
 NO >> Repair or replace harness as necessary.

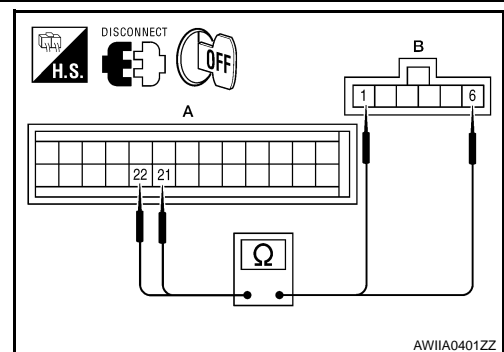

A  
B  
C  
D  
E  
F  
G  
H  
HAC  
J  
K  
L  
M  
N  
O  
P

# DEFROSTER DOOR MOTOR CIRCUIT

< COMPONENT DIAGNOSIS >

[MANUAL A/C (TYPE 1)]

## DEFROSTER DOOR MOTOR CIRCUIT

### System Description

INFOID:000000001669151

### SYSTEM DESCRIPTION

#### Component Parts

Defroster door control system components are:

- Front air control
- Defroster door motor
- PBR (Built into defroster door motor)
- Ambient sensor
- Intake sensor

#### System Operation

The front air control determines defroster door position based on the position of the defroster switch. When the defroster switch is depressed, the defroster door motor rotates directing air to the defroster ducts. When any mode other than defroster is selected, the defroster motor rotates in the opposite direction closing off air flow to the defroster ducts.

### COMPONENT DESCRIPTION

#### Defroster door motor

The defroster door motor is attached to the front heater & cooling unit assembly. The front air control sends a voltage to rotate to the defroster door directing the air flow either to the defroster ducts, or to the floor ducts, depending on which way the voltage and ground are applied to the motor leads. Motor rotation is conveyed to a lever which activates the defroster door.

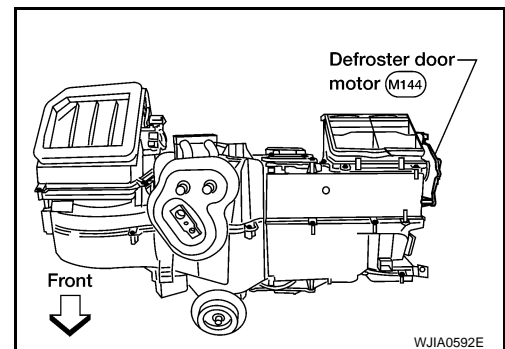

### Defroster Door Motor Component Function Check

INFOID:000000001669152

### INSPECTION FLOW

#### 1. CONFIRM SYMPTOM BY PERFORMING OPERATIONAL CHECK - DEFROSTER DOOR

1. Select vent (V) mode.
2. Press the defrost switch (W). Defroster indicator should illuminate.
3. Listen for defroster door position change (blower sound should change slightly).

#### Can the symptom be duplicated?

- YES >> GO TO 3.  
NO >> GO TO 2.

#### 2. CHECK FOR ANY SYMPTOMS

Perform a complete operational check for any symptoms. Refer to [HAC-101, "Operational Check"](#).

#### Does another symptom exist?

- YES >> Refer to [HAC-100, "How to Perform Trouble Diagnosis For Quick And Accurate Repair"](#).  
NO >> SYSTEM OK.

#### 3. CHECK FOR SERVICE BULLETINS

Check for any service bulletins.

>> GO TO 4.

#### 4. CHECK DEFROSTER DOOR MOTOR

# DEFROSTER DOOR MOTOR CIRCUIT

< COMPONENT DIAGNOSIS >

[MANUAL A/C (TYPE 1)]

Perform diagnostic procedure for defroster door motor. Refer to [HAC-130. "Defroster Door Motor Component Function Check"](#).

Is the inspection result normal?

YES >> GO TO 5.

NO >> Repair PBR circuit or replace defroster door motor. Refer to [VTL-17. "Removal and Installation"](#).

## 5.CHECK DEFROSTER DOOR OPERATION

Check and verify defroster door mechanism for smooth operation.

Is the inspection result normal?

YES >> Replace defroster door motor. Refer to [VTL-17. "Removal and Installation"](#).

NO >> Repair defroster door mechanism.

## Defroster Door Motor Diagnosis Procedure

INFOID:000000001669153

SYMPTOM:

- Defroster door does not change.
- Defroster door motor does not operate normally.

## DIAGNOSTIC PROCEDURE FOR DEFROSTER DOOR MOTOR

### 1.CHECK FRONT AIR CONTROL FOR POWER AND GROUND

1. Turn ignition switch ON.
2. Press the defroster switch (☞).
3. Check voltage between front air control harness connector M49 terminal 24 and terminal 23 and then press the defroster switch (☞) again.

Connector	Terminals		Condition	Voltage (Approx.)
	(+)	(-)		
Front air control: M49	24	23	Press defroster switch	Battery voltage

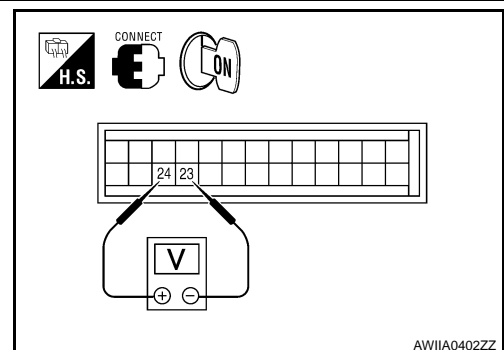

Is the inspection result normal?

YES >> GO TO 4.

NO >> GO TO 3.

### 2.CHECK DEFROSTER DOOR MOTOR CIRCUITS FOR SHORT TO GROUND

1. Turn ignition switch OFF.
2. Disconnect the front air control harness connector.
3. Check continuity between front air control harness connector M49 terminal 23, 24 and ground.

**23 - Ground : Continuity should not exist.**

**24 - Ground : Continuity should not exist.**

Is the inspection result normal?

YES >> Replace front air control. Refer to [VTL-8. "Removal and Installation"](#)

NO >> Repair or replace harness as necessary.

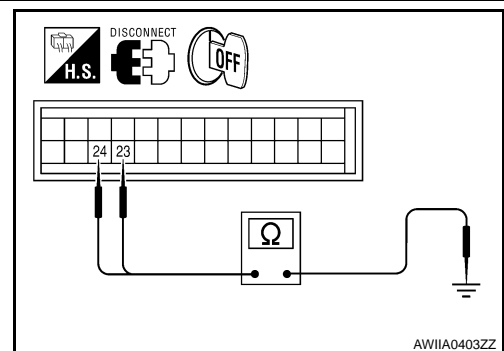

### 3.CHECK FRONT AIR CONTROL FOR GROUND AND POWER



# DEFROSTER DOOR MOTOR CIRCUIT

## < COMPONENT DIAGNOSIS >

[MANUAL A/C (TYPE 1)]

1. Press the defroster switch (  ).
2. Check voltage between front air control harness connector M49 terminal 23 and terminal 24 and the press the defroster switch (  ) again.

Connector	Terminals		Condition	Voltage (Approx.)
	(+)	(-)		
Front air control: M49	23	24	Press defroster switch	Battery voltage

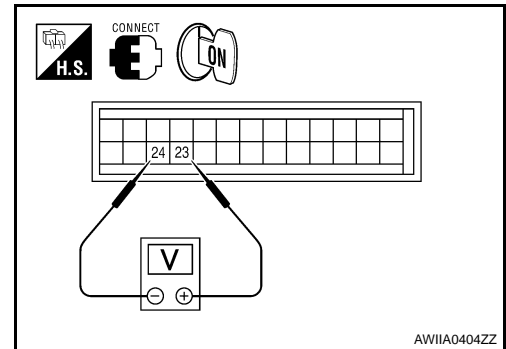

Is the inspection result normal?

YES >> GO TO 5.

NO >> Replace front air control. Refer to [VTL-8. "Removal and Installation"](#).

### 4. CHECK DEFROSTER DOOR MOTOR AND CIRCUITS FOR OPEN

1. Turn ignition switch OFF.
2. Disconnect the front air control harness connector.
3. Check continuity between front air control harness connector M49 terminal 23 and terminal 24.

**Continuity should exist.**

Is the inspection result normal?

YES >> GO TO 7.

NO >> GO TO 6.

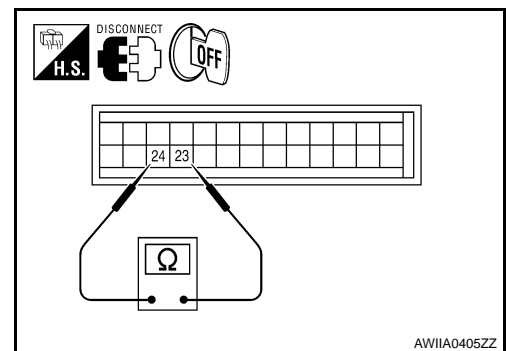

### 5. CHECK DEFROSTER DOOR MOTOR CIRCUITS FOR OPEN

1. Disconnect the defroster door motor harness connector.
2. Check continuity between front air control harness connector M49 terminal 23, 24 and the defroster door motor harness connector M144 terminal 1, 6.

**23 - 1 : Continuity should exist.**

**24 - 6 : Continuity should exist.**

Is the inspection result normal?

YES >> Replace defroster door motor. Refer to [VTL-17. "Removal and Installation"](#).

NO >> Repair or replace harness as necessary.

### 6. CHECK FRONT AIR CONTROL FOR PBR POWER AND GROUND

1. Reconnect front air control harness connector.
2. Turn ignition switch ON.
3. Check voltage between front air control harness connector M50 (A) terminal 28 and M49 (B) terminal 3.

Connector	Terminals		Voltage (Approx.)
	(+)	(-)	
Front air control: M50, M49	28	3	5V

Is the inspection result normal?

YES >> GO TO 9.

NO >> GO TO 8.

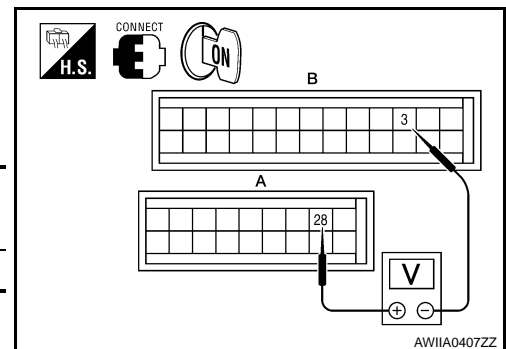

### 7. CHECK PBR REFERENCE VOLTAGE CIRCUIT FOR SHORT TO GROUND

# DEFROSTER DOOR MOTOR CIRCUIT

## < COMPONENT DIAGNOSIS >

[MANUAL A/C (TYPE 1)]

1. Turn ignition switch OFF.
2. Disconnect the front air control harness connector.
3. Check continuity between front air control harness connector M50 terminal 28 and ground.

**Continuity should not exist.**

Is the inspection result normal?

- YES >> Replace front air control. Refer to [VTL-8, "Removal and Installation"](#).
- NO >> Repair or replace harness as necessary.

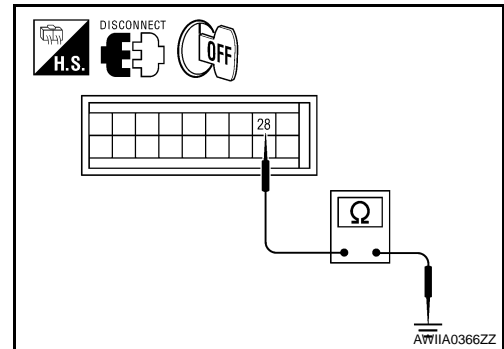

## 8. CHECK PBR REFERENCE VOLTAGE AND GROUND CIRCUITS

1. Turn ignition switch OFF.
2. Disconnect the front air control harness connector.
3. Check continuity between front air control harness connector M50 terminal 28 (A) and M49 (B) terminal 3.

**Continuity should exist.**

Is the inspection result normal?

- YES >> GO TO 11.
- NO >> GO TO 10.

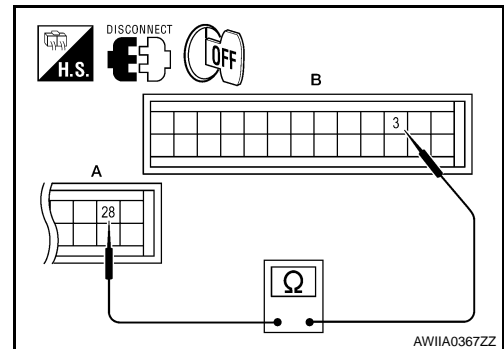

## 9. CHECK PBR REFERENCE VOLTAGE CIRCUIT FOR OPEN

1. Disconnect the defroster door motor harness connector.
2. Check continuity between defroster door motor harness connector M144 (B) terminal 3, 2 and front air control harness connector M50 (A) terminal 28, and M49 (C) terminal 3.

**28 - 3 : Continuity should exist.**

**3 - 2 : Continuity should exist.**

Is the inspection result normal?

- YES >> Replace defroster door motor. Refer to [VTL-17, "Removal and Installation"](#).
- NO >> Repair or replace harness as necessary.

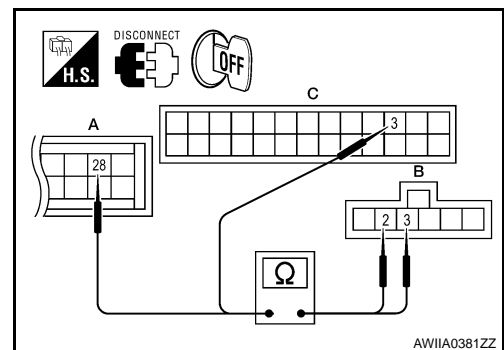

## 10. CHECK PBR FEEDBACK VOLTAGE

1. Reconnect the front air control harness connector.
2. Turn ignition switch ON.
3. Check voltage between front air control harness connector M49 terminal 10 and ground while cycling defroster switch on and off.

**Voltage : Approx. 1V - 4.5V**

Is the inspection result normal?

- YES >> GO TO 13.
- NO >> GO TO 12.

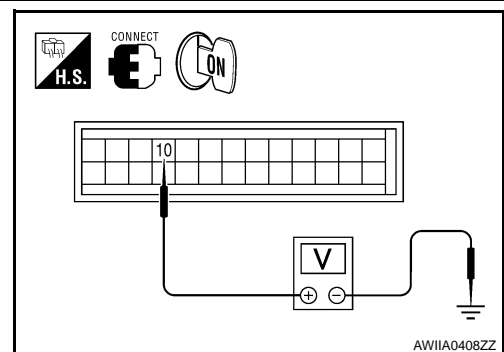

## 11. CHECK PBR FEEDBACK SIGNAL CIRCUIT FOR SHORT TO GROUND

A  
B  
C  
D  
E  
F  
G  
H  
HAC  
J  
K  
L  
M  
N  
O  
P

# DEFROSTER DOOR MOTOR CIRCUIT

[MANUAL A/C (TYPE 1)]

## < COMPONENT DIAGNOSIS >

1. Turn ignition switch OFF.
2. Disconnect front air control harness connector.
3. Check continuity between front air control harness connector M49 terminal 10 and ground.

**Continuity should not exist.**

Is the inspection result normal?

YES >> Replace front air control. Refer to [VTL-8, "Removal and Installation"](#).

NO >> Repair or replace harness as necessary.

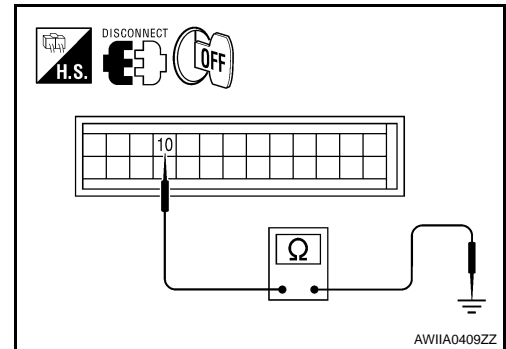

## 12. CHECK PBR FEEDBACK CIRCUIT FOR OPEN

1. Turn ignition switch OFF.
2. Disconnect the defroster door motor harness connector and front air control harness connector.
3. Check continuity between defroster door motor harness connector M144 (B) terminal 4 and front air control harness connector M49 (A) terminal 10

**Continuity should exist.**

Is the inspection result normal?

YES >> Replace defroster door motor. Refer to [VTL-17, "Removal and Installation"](#).

NO >> Repair or replace harness as necessary.

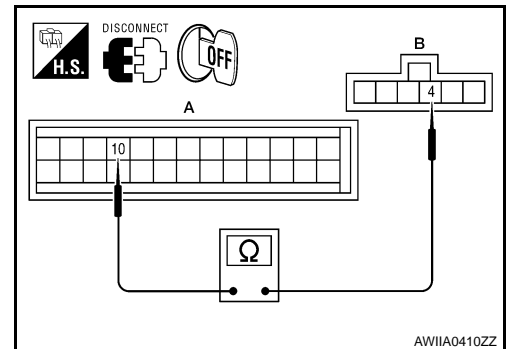

# BLOWER MOTOR CONTROL SYSTEM

< COMPONENT DIAGNOSIS >

[MANUAL A/C (TYPE 1)]

## BLOWER MOTOR CONTROL SYSTEM

### System Description

INFOID:000000001669154

### SYSTEM DESCRIPTION

#### Component Parts

Blower speed control system components are:

- Front air control
- Variable blower control
- Front blower motor relay
- Front blower motor
- Ambient sensor
- Intake sensor

#### System Operation

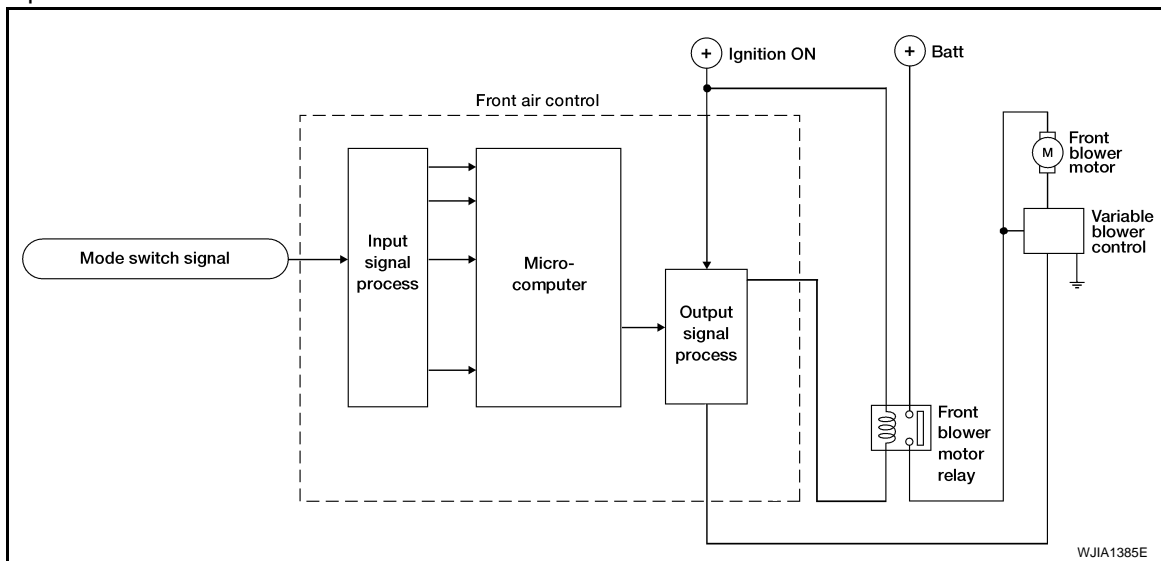

### COMPONENT DESCRIPTION

#### Variable Blower Control

The variable blower control is located on the cooling unit. The variable blower control receives a gate voltage from the front air control to steplessly maintain the blower motor voltage in the 0 to 5 volt range (approx.).

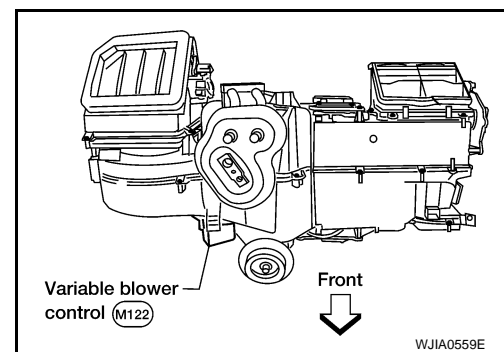

### Front Blower Motor Component Function Check

INFOID:000000001669155

#### INSPECTION FLOW

##### 1. CONFIRM SYMPTOM BY PERFORMING OPERATIONAL CHECK - FRONT BLOWER

1. Rotate the blower control dial clockwise once. Blower motor should operate in low speed.
2. Rotate the blower control dial clockwise, and continue checking blower speed until all speeds are checked.

Can the symptom be duplicated?

YES >> GO TO 3.

A

B

C

D

E

F

G

H

HAC

J

K

L

M

N

O

P





# BLOWER MOTOR CONTROL SYSTEM

< COMPONENT DIAGNOSIS >

[MANUAL A/C (TYPE 1)]

## 1. CHECK FUSES

Check 20A fuses [No. 24 and 27 (Located in the fuse and fusible link box)]. For fuse layout. Refer to [PG-66, "Terminal Arrangement"](#).

**Fuses are good.**

Is the inspection result normal?

- YES >> GO TO 3.
- NO >> GO TO 9.

## 2. CHECK FRONT BLOWER MOTOR POWER SUPPLY CIRCUIT

1. Turn ignition switch OFF.
2. Disconnect front blower motor connector.
3. Turn ignition switch ON.
4. Press the A/C switch.
5. Rotate blower control dial to maximum speed.
6. Check voltage between front blower motor harness connector M62 terminal 2 and ground.

**2 - Ground : Battery voltage**

Is the inspection result normal?

- YES >> GO TO 10.
- NO >> GO TO 3.

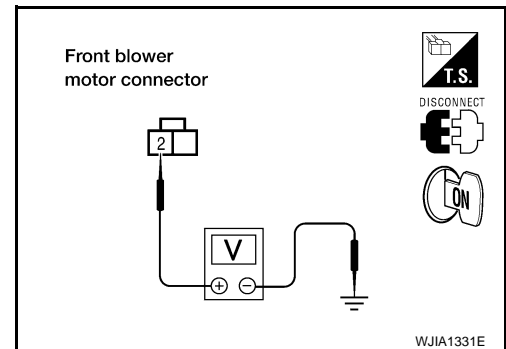

## 3. CHECK FRONT BLOWER MOTOR RELAY (SWITCH SIDE) POWER SUPPLY CIRCUIT

1. Turn ignition switch OFF.
2. Disconnect front blower motor relay.
3. Check voltage between front blower motor relay harness connector M107 terminal 5 and ground.

**5 - Ground : Battery voltage**

Is the inspection result normal?

- YES >> GO TO 4.
- NO >> Repair harness or connector.

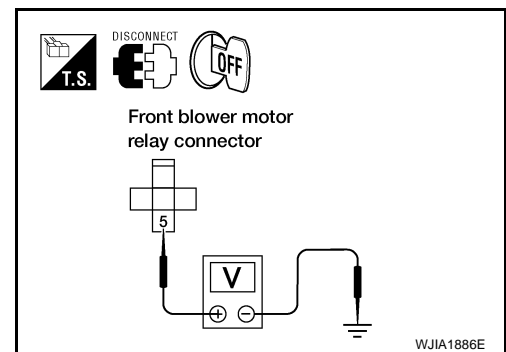

## 4. CHECK FRONT BLOWER MOTOR RELAY

Turn ignition switch OFF.

Check front blower motor relay. Refer to [HAC-139, "Front Blower Motor Component Inspection"](#).

Is the inspection result normal?

- YES >> GO TO 5.
- NO >> Replace front blower motor relay.

## 5. CHECK FRONT BLOWER MOTOR RELAY (SWITCH SIDE) CIRCUIT FOR OPEN

Check continuity between front blower motor relay harness connector M107 terminal 3 and front blower motor harness connector M62 terminal 2.

**3 - 2 : Continuity should exist.**

Is the inspection result normal?

- YES >> GO TO 6.
- NO >> Repair harness or connector.

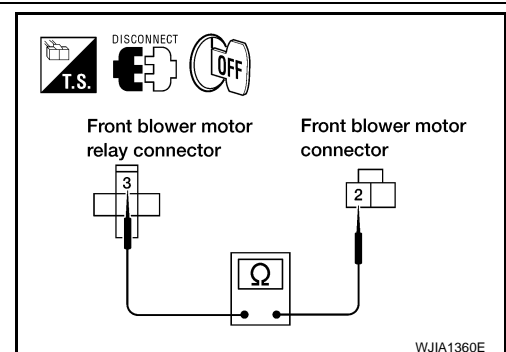

## 6. CHECK VARIABLE BLOWER CONTROL POWER SUPPLY CIRCUIT FOR OPEN

# BLOWER MOTOR CONTROL SYSTEM

## < COMPONENT DIAGNOSIS >

[MANUAL A/C (TYPE 1)]

1. Disconnect variable blower control harness connector.
2. Check continuity between front blower motor relay harness connector M107 (A) terminals 3 and variable blower control harness connector M122 (B) terminal 4.

**3 - 4 : Continuity should exist.**

Is the inspection result normal?

- YES >> GO TO 7.  
NO >> Repair harness or connector.

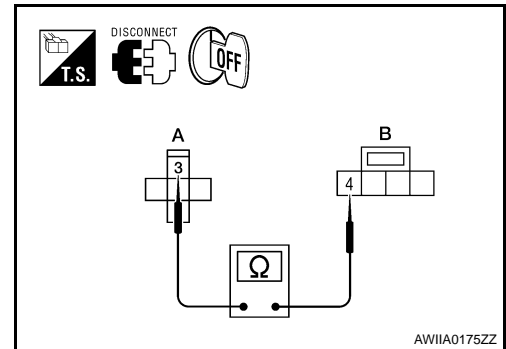

## 7. CHECK VARIABLE BLOWER CONTROL SIGNAL CIRCUIT

1. Disconnect front air control connector.
2. Check continuity between front air control harness connector M49 (B) terminal 13 and variable blower control harness connector M122 (A) terminal 3.

**13 - 3 : Continuity should exist.**

Is the inspection result normal?

- YES >> GO TO 8.  
NO >> Repair harness or connector.

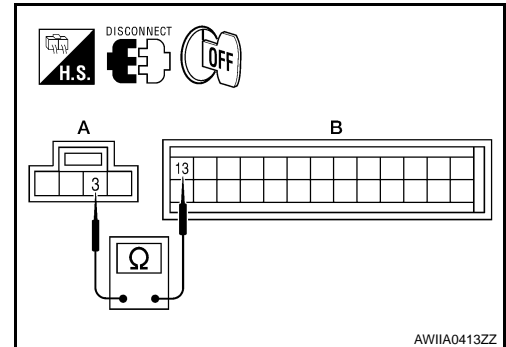

## 8. CHECK FRONT BLOWER MOTOR RELAY (COIL SIDE) POWER SUPPLY

1. Turn ignition switch ON.
2. Check voltage between front blower motor relay harness connector M107 terminal 2 and ground.

**2 - Ground : Battery voltage**

Is the inspection result normal?

- YES >> GO TO 9.  
NO >> Repair front blower motor ground circuit or connector.

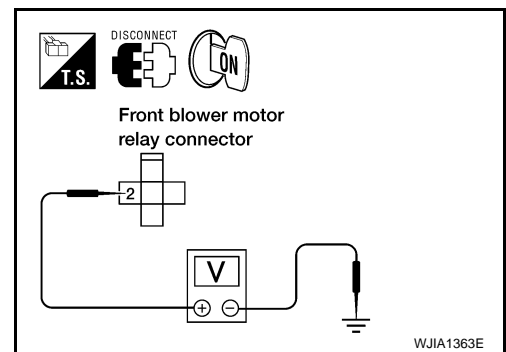

## 9. REPLACE FUSES

1. Replace fuses.
2. Activate the front blower motor.

Does the fuse blow?

- YES >> GO TO 10.  
NO >> Inspection End.

## 10. CHECK FRONT BLOWER MOTOR POWER SUPPLY CIRCUIT FOR SHORT

1. Turn ignition switch OFF.
2. Disconnect front blower motor connector and variable blower control connector.
3. Check continuity between variable blower control harness connector M122 terminal 4 and ground.

**4 - Ground : Continuity should not exist.**

Is the inspection result normal?

- YES >> GO TO 11.  
NO >> Repair harness or connector.

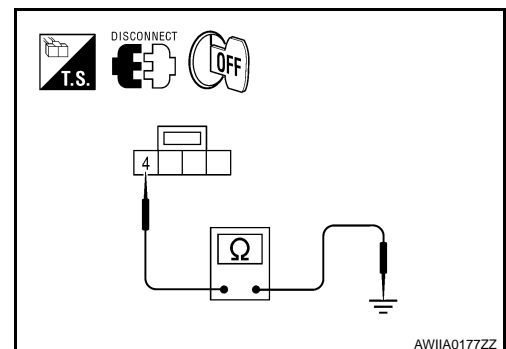

## 11. CHECK VARIABLE BLOWER CONTROL SIGNAL CIRCUIT

# BLOWER MOTOR CONTROL SYSTEM

[MANUAL A/C (TYPE 1)]

## < COMPONENT DIAGNOSIS >

1. Disconnect front air control connector.
2. Check continuity between front air control harness connector M49 (B) terminal 13 and variable blower control harness connector M122 (A) terminal 3.

**13 - 3 : Continuity should exist.**

Is the inspection result normal?

YES >> GO TO 12.

NO >> Repair harness or connector.

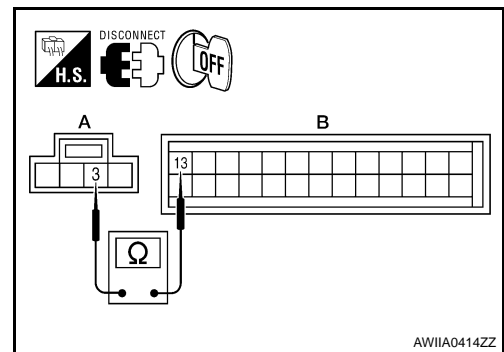

## 12. CHECK FRONT BLOWER MOTOR

Check front blower motor. Refer to [HAC-135, "Front Blower Motor Component Function Check"](#).

Is the inspection result normal?

YES >> GO TO 13.

NO >> Replace front blower motor. Refer to [VTL-12, "Removal and Installation"](#).

## 13. CHECK BLOWER MOTOR GROUND CIRCUIT

Check continuity between front blower motor harness connector M62 terminal 1 and variable blower control harness connector M122 terminal 2.

**1 - 2 : Continuity should exist.**

Is the inspection result normal?

YES >> GO TO 14.

NO >> Repair harness or connector.

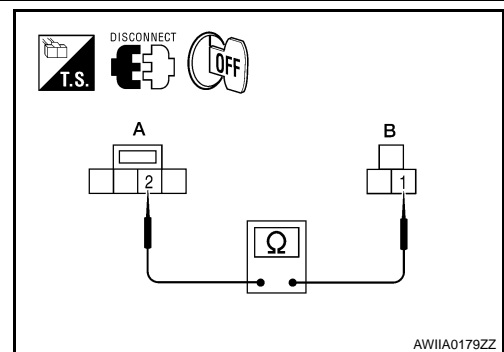

## 14. CHECK VARIABLE BLOWER CONTROL GROUND CIRCUIT

Check continuity between variable blower control harness connector M122 terminal 1 and ground.

**1 - Ground : Continuity should exist.**

Is the inspection result normal?

YES >> Replace variable blower control. Refer to [VTL-22, "Removal and Installation"](#).

NO >> Repair harness or connector.

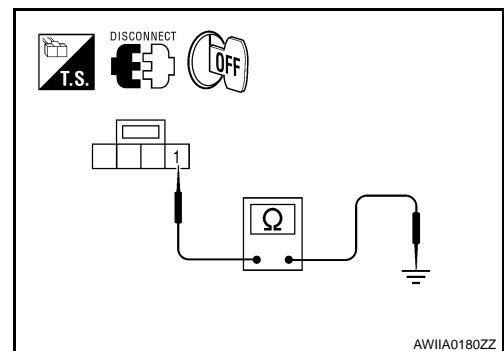

## Front Blower Motor Component Inspection

INFOID:000000001669157

## COMPONENT INSPECTION

# BLOWER MOTOR CONTROL SYSTEM

## < COMPONENT DIAGNOSIS >

[MANUAL A/C (TYPE 1)]

Check continuity between terminals 3 and 5 by supplying 12 volts and ground to coil side terminals 1 and 2 of the relay.

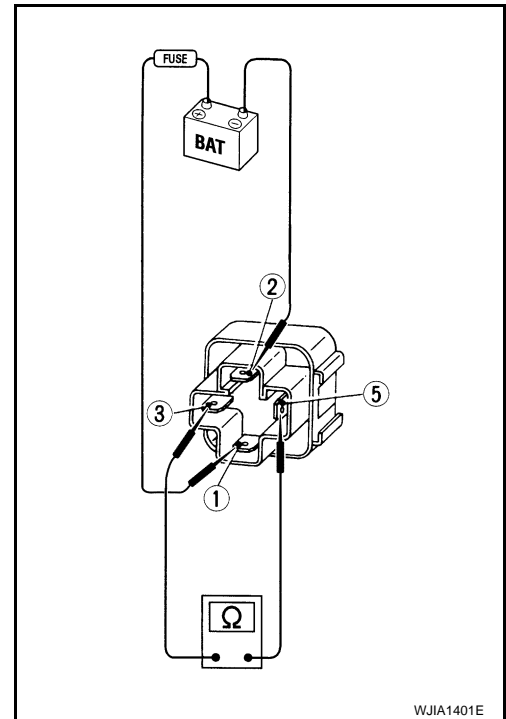

### Front Blower Motor

Confirm smooth rotation of the blower motor.

- Ensure that there are no foreign particles inside the blower unit.
- Apply 12 volts to terminal 2 and ground to terminal 1 and verify that the motor operates freely and quietly.

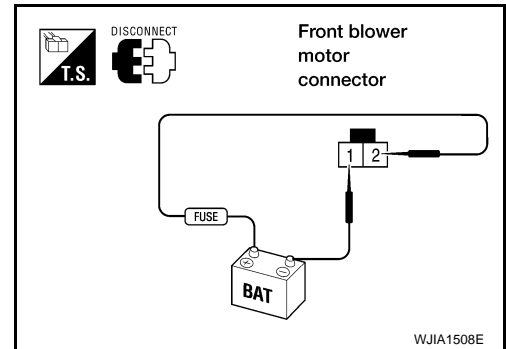

MAGNET CLUTCH

System Description

INFOID:000000001669158

SYSTEM DESCRIPTION

The front air control controls compressor operation based on ambient and intake temperature and a signal from ECM.

Low Temperature Protection Control

The front air control will turn the compressor ON or OFF as determined by a signal detected by the intake sensor and the ambient sensor.

When intake air temperature is higher than the preset value, the compressor turns ON. The compressor turns OFF when intake air temperature is lower than the preset value. That preset value is dependent on the ambient temperature, refer to the following table.

Ambient temperature °C (°F)	Compressor ON intake temperature °C (°F)	Compressor OFF intake temperature °C (°F)
0 (32)	5.5 (42)	5.0 (41)
10 (50)	5.5 (42)	5.0 (41)
20 (68)	5.5 (42)	5.0 (41)
30 (86)	4.0 (39)	3.5 (38)
40 (104)	3.5 (38)	3.0 (37)
50 (122)	3.5 (38)	3.0 (37)

Magnet Clutch Component Function Check

INFOID:000000001669159

INSPECTION FLOW

1.CONFIRM SYMPTOM BY PERFORMING OPERATIONAL CHECK - MAGNET CLUTCH

1. Turn ignition switch ON.
2. Turn the blower control dial to low speed and press the A/C switch.
3. Press vent mode switch (↺).
4. Confirm that the compressor clutch engages (sound or visual inspection). (Discharge air and blower speed will depend on ambient, in-vehicle and set temperatures.)

Can the symptom be duplicated?

- YES >> GO TO 3.
- NO >> GO TO 2.

2.CHECK FOR ANY SYMPTOMS

Perform a complete operational check for any symptoms. Refer to [HAC-101, "Operational Check"](#).

Does another symptom exist?

- YES >> Refer to [HAC-100, "How to Perform Trouble Diagnosis For Quick And Accurate Repair"](#).
- NO >> System OK.

3.CHECK FOR SERVICE BULLETINS

Check for any service bulletins.

>> GO TO 4.

4.CHECK AMBIENT SENSOR

Check and verify ambient sensor circuit. Refer to [HAC-148, "Ambient Sensor Diagnosis Procedure"](#).

>> GO TO 5.

5.CHECK INTAKE SENSOR

Check and verify intake sensor circuit. Refer to [HAC-151, "Intake Sensor Diagnosis Procedure"](#).

A  
B  
C  
D  
E  
F  
G  
H

HAC

J  
K  
L  
M  
N  
O  
P

# MAGNET CLUTCH

< COMPONENT DIAGNOSIS >

[MANUAL A/C (TYPE 1)]

>> GO TO 6.

## 6. RECHECK FOR ANY SYMPTOMS

Perform a complete operational check for any symptoms. Refer to [HAC-101. "Operational Check"](#).

Does another symptom exist?

YES >> Refer to [HAC-100. "How to Perform Trouble Diagnosis For Quick And Accurate Repair"](#).

NO >> Replace front air control. Refer to [VTL-8. "Removal and Installation"](#).

## Magnet Clutch Diagnosis Procedure

INFOID:000000001669160

### DIAGNOSTIC PROCEDURE FOR MAGNET CLUTCH

SYMPTOM: Magnet clutch does not engage when A/C switch is ON.

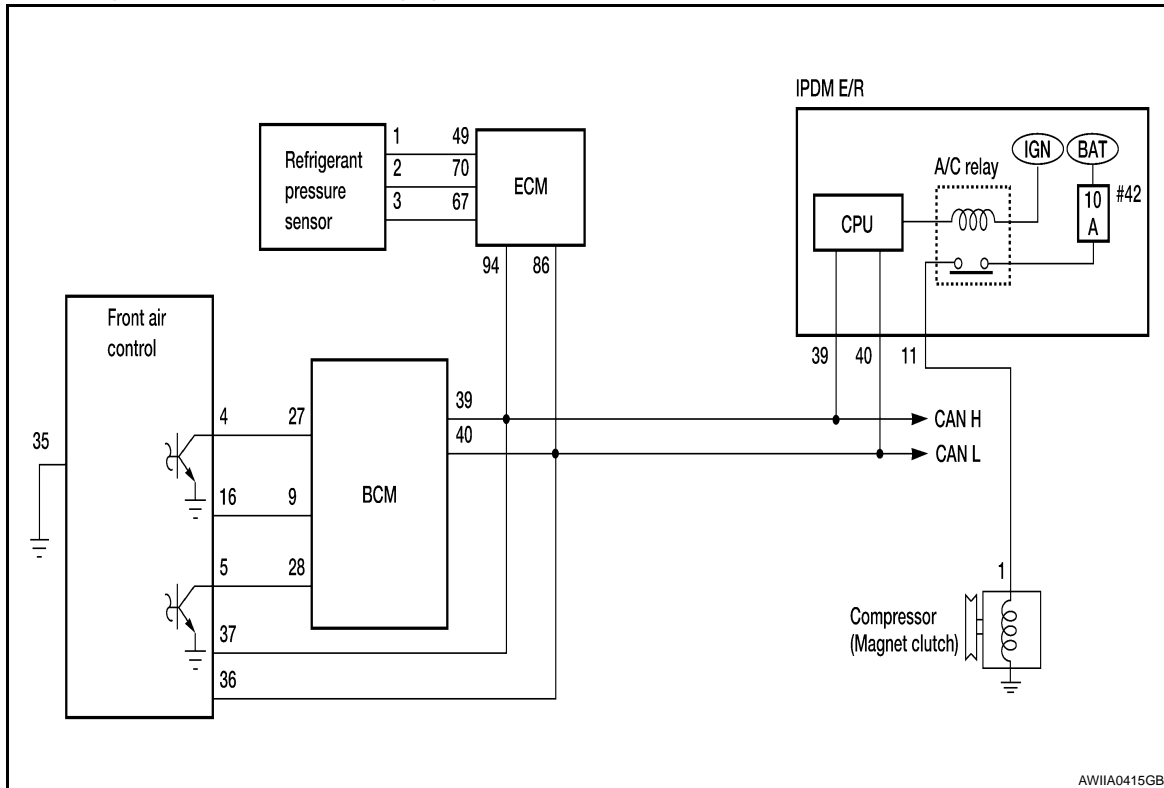

### 1. CHECK INTAKE AND AMBIENT SENSOR CIRCUITS

Check intake and ambient sensors. Refer to [HAC-115. "Front Air Control Self-Diagnosis"](#).

Is the inspection result normal?

YES >> GO TO 2.

NO >> • Malfunctioning intake sensor. Refer to [HAC-151. "Intake Sensor Diagnosis Procedure"](#).  
• Malfunctioning ambient sensor. Refer to [HAC-148. "Ambient Sensor Diagnosis Procedure"](#).

### 2. PERFORM AUTO ACTIVE TEST

Refer to XX-XX, IN PG.

Does magnet clutch operate?

YES >> •  WITH CONSULT-III  
GO TO 5.  
•  WITHOUT CONSULT-III  
GO TO 6.

NO >> Check 10A fuse (No. 42, located in IPDM E/R), and GO TO 3.

### 3. CHECK CIRCUIT CONTINUITY BETWEEN IPDM E/R AND COMPRESSOR

# MAGNET CLUTCH

## < COMPONENT DIAGNOSIS >

[MANUAL A/C (TYPE 1)]

1. Turn ignition switch OFF.
2. Disconnect IPDM E/R connector and compressor (magnet clutch) connector.
3. Check continuity between IPDM E/R harness connector E119 terminal 11 and A/C compressor harness connector F3 terminal 1.

**11 - 1 : Continuity should exist.**

Is the inspection result normal?

- YES >> GO TO 4.  
NO >> Repair harness or connector.

### 4. CHECK MAGNET CLUTCH CIRCUIT

Check for operation sound when applying battery voltage direct current to terminal.

Is the inspection result normal?

- YES >> Replace IPDM E/R. Refer to [PCS-30, "Removal and Installation of IPDM E/R"](#).  
NO >> Replace magnet clutch. Refer to [HA-34, "Removal and Installation for Compressor Clutch"](#).

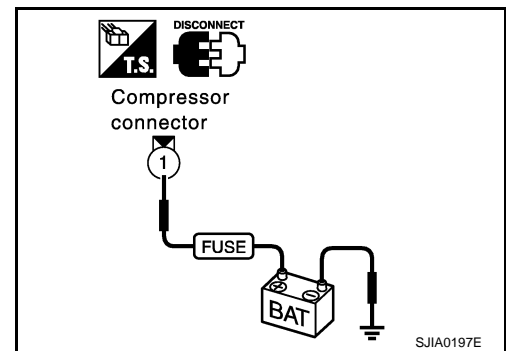
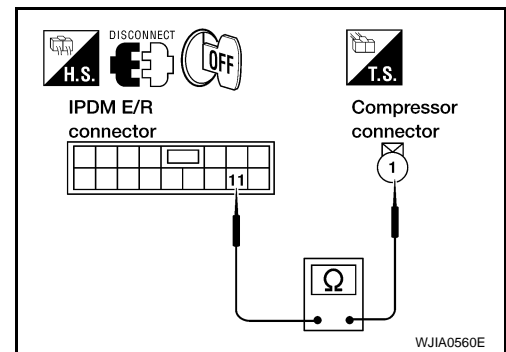

### 5. CHECK BCM INPUT (COMPRESSOR ON) SIGNAL

Check compressor ON/OFF signal. Refer to [HAC-113, "CONSULT-III Function \(HVAC\)"](#).

**A/C SW ON : COMP ON SIG ON**  
**A/C SW OFF : COMP ON SIG OFF**

Is the inspection result normal?

- YES >> GO TO 8.  
NO >> GO TO 6.

### 6. CHECK CIRCUIT CONTINUITY BETWEEN BCM AND FRONT AIR CONTROL

1. Turn ignition switch OFF.
2. Disconnect BCM connector and front air control connector.
3. Check continuity between BCM harness connector M18 (A) terminal 27 and front air control harness connector M49 (B) terminal 4.

**27 - 4 Continuity should exist.**

Is the inspection result normal?

- YES >> GO TO 7.  
NO >> Repair harness or connector.

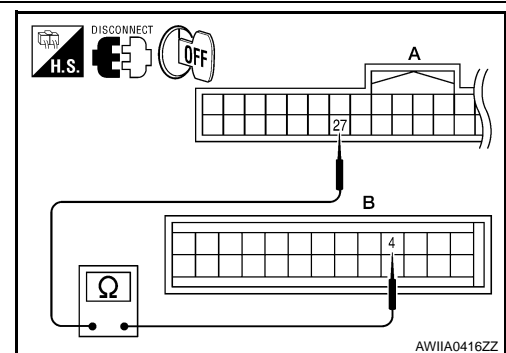

### 7. CHECK VOLTAGE FOR FRONT AIR CONTROL (A/C COMPRESSOR ON SIGNAL)

# MAGNET CLUTCH

## < COMPONENT DIAGNOSIS >

[MANUAL A/C (TYPE 1)]

1. Reconnect BCM connector and front air control connector.
2. Turn ignition switch ON.
3. Check voltage between front air control harness connector M49 terminal 4 and ground.

Terminals		(-)	Condition	Voltage
(+) Terminal No.				
front air control connector	Terminal No.			
M49	4	Ground	A/C switch: ON	Approx. 0V
			A/C switch: OFF	Approx. 5V

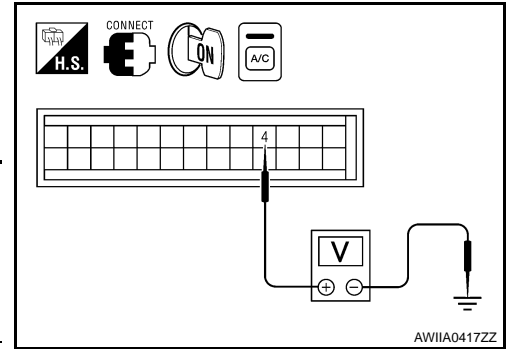

Is the inspection result normal?

YES >> GO TO 8.

NO-1 >> If the voltage is approx. 5V when A/C switch is ON, replace front air control. Refer to [VTL-8, "Removal and Installation"](#).

NO-2 >> If the voltage is approx. 0V when A/C switch is OFF, replace BCM. Refer to [BCS-50, "Removal and Installation"](#).

## 8. CHECK REFRIGERANT PRESSURE SENSOR

1. Start engine.
2. Check voltage between ECM harness connector F54 terminal 70 and ground.

Terminals		(-)	Condition	Voltage
(+) Terminal No.				
ECM connector	Terminal No.			
F54	70	Ground	A/C switch: ON	Approx. 0.36 - 3.88V

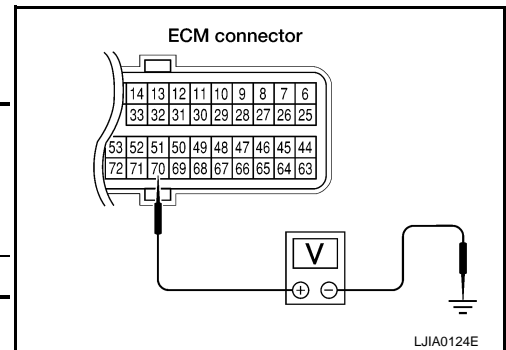

Is the inspection result normal?

YES >> GO TO 9.

NO >> Refer to [EC-412, "Diagnosis Procedure"](#).

## 9. CHECK BCM INPUT (FAN ON) SIGNAL

Check FAN ON/OFF signal. Refer to [HAC-113, "CONSULT-III Function \(HVAC\)"](#).

**FRONT BLOWER CONTROL : FAN ON SIG ON  
DIAL ON**

**FRONT BLOWER CONTROL : FAN ON SIG OFF  
DIAL OFF**

Is the inspection result normal?

YES >> GO TO 12.

NO >> GO TO 10.

## 10. CHECK CIRCUIT CONTINUITY BETWEEN BCM AND FRONT AIR CONTROL



# MAGNET CLUTCH

## < COMPONENT DIAGNOSIS >

[MANUAL A/C (TYPE 1)]

1. Turn ignition switch OFF.
2. Disconnect BCM connector and front air control connector.
3. Check continuity between BCM harness connector M18 (A) terminal 28 and front air control harness connector M49 terminal 5.

**28 - 5**

**Continuity should exist.**

Is the inspection result normal?

YES >> GO TO 11.

NO >> Repair harness or connector.

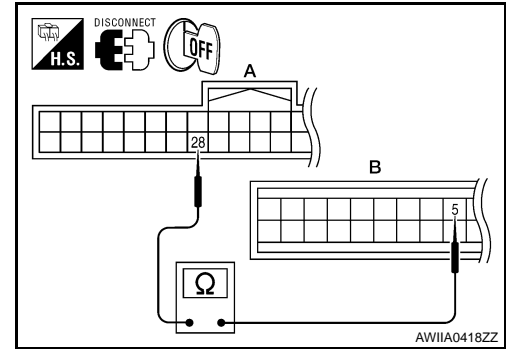

## 11. CHECK VOLTAGE FOR FRONT AIR CONTROL (FAN ON SIGNAL)

1. Reconnect BCM connector and front air control connector.
2. Turn ignition switch ON.
3. Check voltage between front air control harness connector M49 terminal 5 and ground.

Terminals		(-)	Condition	Voltage
(+)	Terminal No.			
front air control connector				
M49	5	Ground	A/C switch: ON Blower motor operates	Approx. 0V
			A/C switch: OFF	Approx. 5V

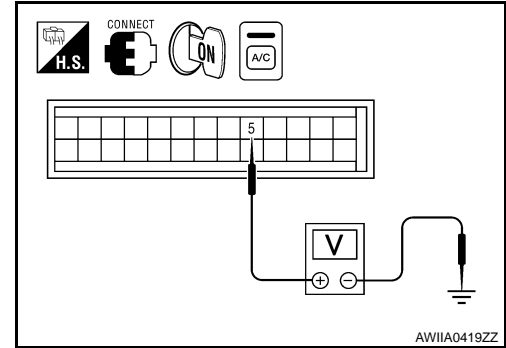

Is the inspection result normal?

YES >> GO TO 12.

NO-1 >> If the voltage is approx. 5V when blower motor is ON, replace front air control. Refer to [VTL-8, "Removal and Installation"](#).

NO-2 >> If the voltage is approx. 0V when blower motor is OFF, replace BCM. Refer to [BCS-50, "Removal and Installation"](#).

## 12. CHECK CAN COMMUNICATION

Check CAN communication. Refer to [LAN-4, "System Description"](#).

- BCM – ECM
- ECM – IPDM E/R
- ECM – Front air control

Is the inspection result normal?

YES >> Inspection End.

NO >> Repair or replace malfunctioning part(s).

A  
B  
C  
D  
E  
F  
G  
H  
J  
K  
L  
M  
N  
O  
P

HAC

## WATER VALVE CIRCUIT

### Description

INFOID:000000001669161

### COMPONENT DESCRIPTION

#### Water Valve

The water valve (1) cuts the flow of engine coolant to the heater core to allow for maximum cooling during A/C operation. It is controlled by the front air control.

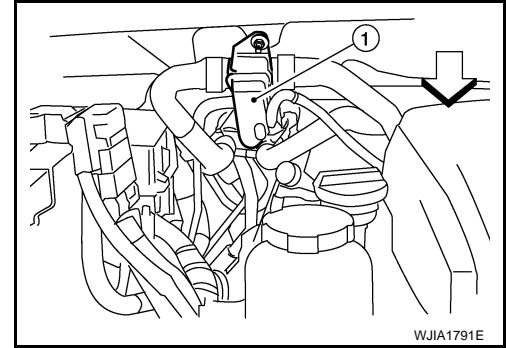

### Water Valve Diagnosis Procedure

INFOID:000000001669162

#### DIAGNOSTIC PROCEDURE FOR WATER VALVE

### 1. CHECK WATER VALVE POWER AND GROUND CIRCUITS

1. Disconnect water valve connector F68.
2. Turn ignition switch ON.
3. Rotate temperature control dial to maximum heat.
4. Check voltage between water valve harness connector F68 terminal 1 and terminal 2 while rotating temperature control dial to maximum cold.

Connector	Terminals		Condition	Voltage (Approx.)
	(+)	(-)		
Water valve: F68	2	1	Rotate temperature control dial	Battery voltage

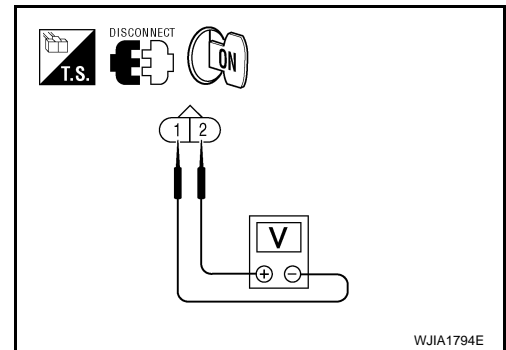

Is the inspection result normal?

- YES >> GO TO 3.  
 NO >> GO TO 2.

### 2. CHECK WATER VALVE CONTROL OUTPUT CIRCUIT

1. Turn ignition switch OFF.
2. Disconnect front air control connector M50.
3. Check continuity between water valve harness connector F68 (A) terminal 2 and front air control harness connector M50 (B) terminal 42.

**2 - 42 : Continuity should exist.**

4. Check continuity between water valve harness connector F68 terminal 2 and ground.

**2 - Ground : Continuity should not exist.**

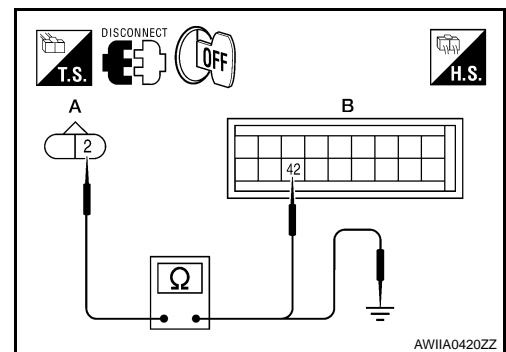

Is the inspection result normal?

- YES >> Replace front air control. Refer to [VTL-8, "Removal and Installation"](#).  
 NO >> Repair harness or connector.

### 3. CHECK WATER VALVE POWER AND GROUND CIRCUITS

# WATER VALVE CIRCUIT

## < COMPONENT DIAGNOSIS >

[MANUAL A/C (TYPE 1)]

1. Rotate temperature control dial to maximum cold.
2. Check voltage between water valve harness connector F68 terminal 1 and terminal 2 while rotating temperature control dial to maximum heat.

Connector	Terminals		Condition	Voltage (Approx.)
	(+)	(-)		
Water valve: F68	1	2	Rotate temperature control dial	Battery voltage

**Is the inspection result normal?**

- YES >> Replace the water valve.  
 NO >> GO TO 4.

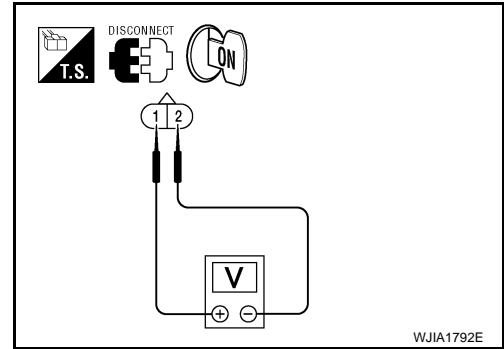

## 4. CHECK WATER VALVE CONTROL OUTPUT CIRCUIT

1. Turn ignition switch OFF.
2. Disconnect front air control connector M50.
3. Check continuity between water valve harness connector F68 (A) terminal 1 and front air control harness connector M50 (B) terminal 41.

**1 - 41 : Continuity should exist.**

4. Check continuity between water valve harness connector F68 (A) terminal 1 and ground.

**1 - Ground : Continuity should not exist.**

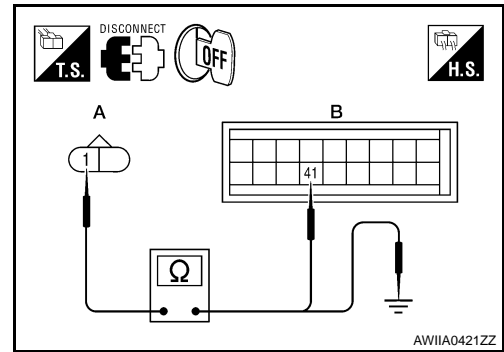

**Is the inspection result normal?**

- YES >> Replace front air control. Refer to [VTL-8, "Removal and Installation"](#).  
 NO >> Repair harness or connector.

A  
B  
C  
D  
E  
F  
G  
H  
J  
K  
L  
M  
N  
O  
P

HAC

## AMBIENT SENSOR

### Component Description

INFOID:000000001669163

#### COMPONENT DESCRIPTION

##### Ambient Sensor

The ambient sensor (1) is attached on the radiator core support (left side). It detects ambient temperature and converts it into a value which is then input into the front air control.

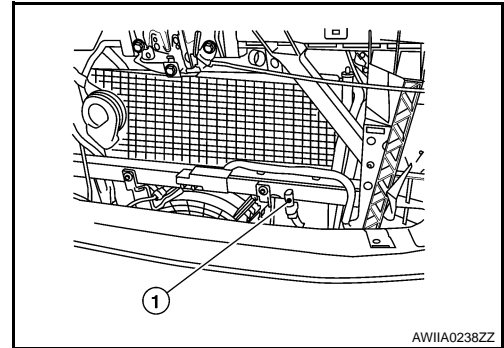

#### AMBIENT TEMPERATURE INPUT PROCESS

The front air control includes a processing circuit for the ambient sensor input. However, when the temperature detected by the ambient sensor increases quickly, the processing circuit retards the front air control function. It only allows the front air control to recognize an ambient temperature increase of 0.33°C (0.6°F) per 100 seconds.

This prevents constant adjustments due to momentary conditions, such as stopping after high speed driving. Although the actual ambient temperature has not changed, the temperature detected by the ambient sensor will increase. This is because the heat from the engine compartment can radiate to the front grille area, location of the ambient sensor.

### Ambient Sensor Diagnosis Procedure

INFOID:000000001669164

#### DIAGNOSTIC PROCEDURE FOR AMBIENT SENSOR

SYMPTOM: Ambient sensor circuit is open or shorted.

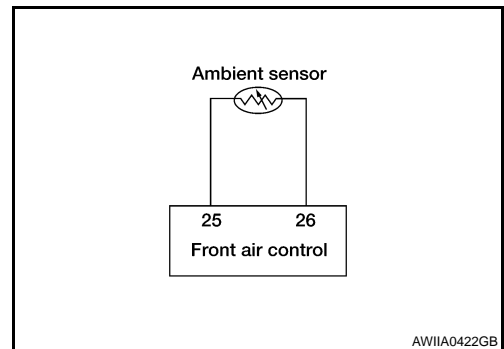

### 1. CHECK VOLTAGE BETWEEN AMBIENT SENSOR AND GROUND

1. Disconnect ambient sensor connector.
2. Turn ignition switch ON.
3. Check voltage between ambient sensor harness connector E1 terminal 1 and ground.

**1 - Ground : Approx. 5V**

Is the inspection result normal?

- YES >> GO TO 3.  
NO >> GO TO 5.

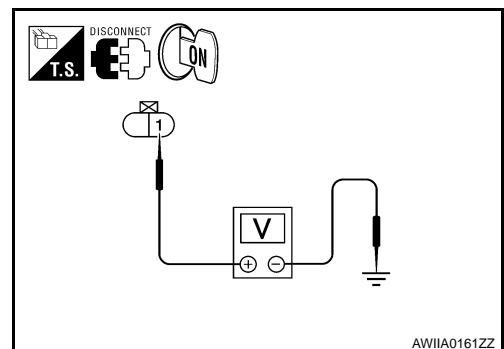

### 2. CHECK CIRCUIT CONTINUITY BETWEEN AMBIENT SENSOR AND FRONT AIR CONTROL

# AMBIENT SENSOR

## < COMPONENT DIAGNOSIS >

[MANUAL A/C (TYPE 1)]

1. Turn ignition switch OFF.
2. Disconnect front air control connector.
3. Check continuity between ambient sensor harness connector E1 (B) terminal 1 and front air control harness connector M49 (A) terminal 25.

**1 - 25 : Continuity should exist.**

Is the inspection result normal?

- YES >> GO TO 4.  
NO >> Repair harness or connector.

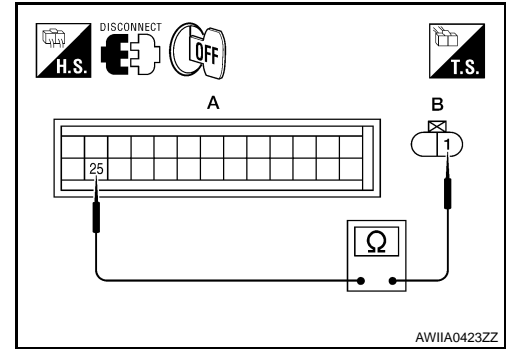

### 3. CHECK AMBIENT SENSOR

Check the Ambient Sensor Circuit. Refer to [HAC-148, "Ambient Sensor Diagnosis Procedure"](#).

Is the inspection result normal?

- YES >> 1. Replace front air control. Refer to [VTL-8, "Removal and Installation"](#).  
2. GO TO [HAC-115, "Front Air Control Self-Diagnosis"](#) and perform self-diagnosis.  
NO >> 1. Replace ambient sensor.  
2. GO TO [HAC-115, "Front Air Control Self-Diagnosis"](#) and perform self-diagnosis.

### 4. CHECK CIRCUIT CONTINUITY BETWEEN AMBIENT SENSOR AND FRONT AIR CONTROL

1. Turn ignition switch OFF.
2. Disconnect front air control connector.
3. Check continuity between ambient sensor harness connector E1 (B) terminal 2 and front air control harness connector M49 (A) terminal 26.

**2 - 26 : Continuity should exist.**

4. Check continuity between ambient sensor harness connector E1 (B) terminal 2 and ground.

**2 - Ground : Continuity should not exist.**

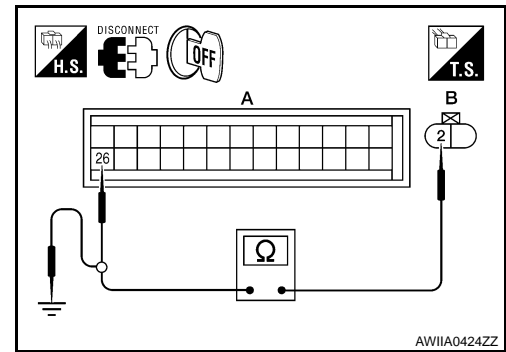

Is the inspection result normal?

- YES >> 1. Replace front air control. Refer to [VTL-8, "Removal and Installation"](#).  
2. GO TO [HAC-115, "Front Air Control Self-Diagnosis"](#) and perform self-diagnosis.  
NO >> Repair harness or connector.

## Ambient Sensor Component Inspection

INFOID:000000001669165

### COMPONENT INSPECTION

Ambient Sensor

# AMBIENT SENSOR

## < COMPONENT DIAGNOSIS >

[MANUAL A/C (TYPE 1)]

After disconnecting ambient sensor (1) connector E1, measure resistance between terminals 1 and 2 at sensor component side, using the table below.

Temperature °C (°F)	Resistance kΩ
-15 (5)	12.73
-10 (14)	9.92
-5 (23)	7.80
0 (32)	6.19
5 (41)	4.95
10 (50)	3.99
15 (59)	3.24
20 (68)	2.65
25 (77)	2.19
30 (86)	1.81
35 (95)	1.51
40 (104)	1.27
45 (113)	1.07

If NG, replace ambient sensor. Refer to [HA-45. "Removal and Installation"](#)

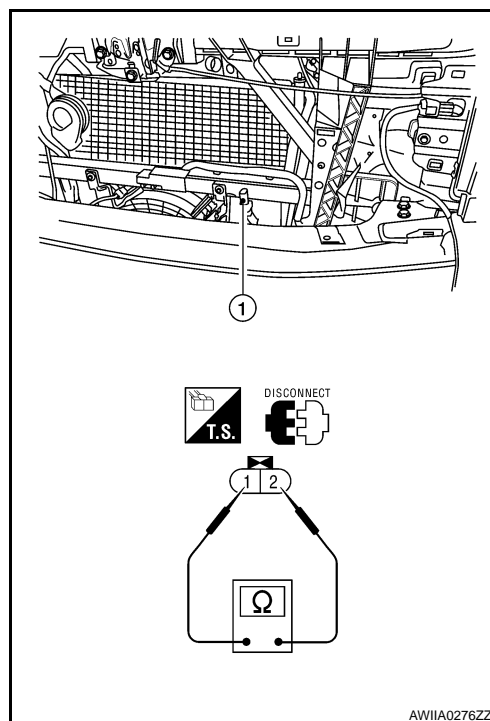

## INTAKE SENSOR

### System Description

INFOID:000000001669171

### COMPONENT DESCRIPTION

#### Intake Sensor

The intake sensor is located on the heater & cooling unit assembly. It converts temperature of air after it passes through the evaporator into a resistance value which is then input to the front air control.

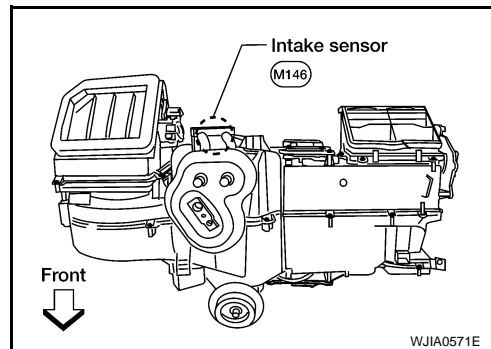

### Intake Sensor Diagnosis Procedure

INFOID:000000001669172

#### DIAGNOSTIC PROCEDURE FOR INTAKE SENSOR

SYMPTOM: Intake sensor circuit is open or shorted.

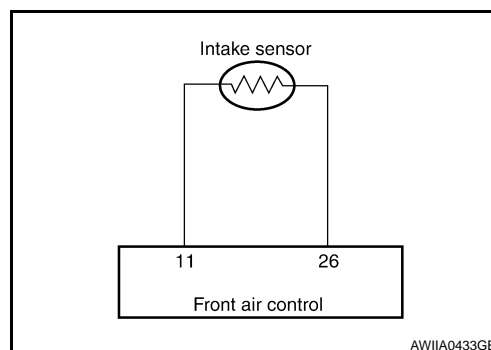

#### 1. CHECK VOLTAGE BETWEEN INTAKE SENSOR AND GROUND

1. Disconnect intake sensor connector.
2. Turn ignition switch ON.
3. Check voltage between intake sensor harness connector M146 terminal 2 and ground.

**2 - Ground : Approx. 5V**

Is the inspection result normal?

- YES >> GO TO 3.  
NO >> GO TO 4.

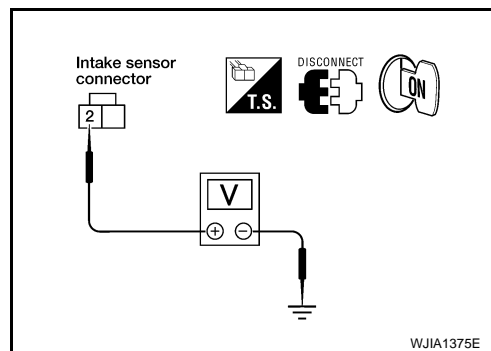

#### 2. CHECK CIRCUIT CONTINUITY BETWEEN INTAKE SENSOR AND FRONT AIR CONTROL

1. Turn ignition switch OFF.
2. Disconnect front air control connector.
3. Check continuity between intake sensor harness connector M146 (B) terminal 1 and front air control harness connector M49 (A) terminal 26.

**1 - 26 : Continuity should exist.**

Is the inspection result normal?

- YES >> GO TO 4.  
NO >> Repair harness or connector.

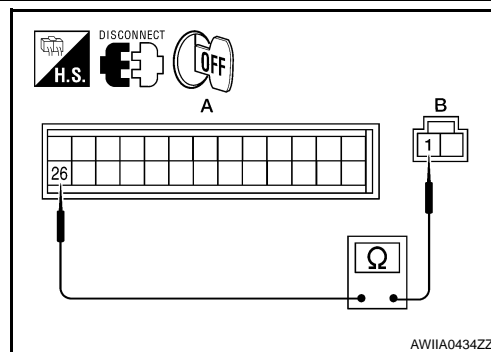

A  
B  
C  
D  
E  
F  
G  
H  
HAC  
J  
K  
L  
M  
N  
O  
P

# INTAKE SENSOR

< COMPONENT DIAGNOSIS >

[MANUAL A/C (TYPE 1)]

## 3. CHECK INTAKE SENSOR

Check intake sensor. Refer to [HAC-152. "Intake Sensor Component Inspection"](#).

Is the inspection result normal?

- YES >> 1. Replace front air control. Refer to [VTL-8. "Removal and Installation"](#).  
 2. Go to [HAC-115. "Front Air Control Self-Diagnosis"](#) and perform self-diagnosis.
- NO >> 1. Replace intake sensor. Refer to [VTL-11. "Removal and Installation"](#).  
 2. Go to [HAC-115. "Front Air Control Self-Diagnosis"](#) and perform self-diagnosis.

## 4. CHECK CIRCUIT CONTINUITY BETWEEN INTAKE SENSOR AND FRONT AIR CONTROL

- Turn ignition switch OFF.
- Disconnect front air control connector.
- Check continuity between intake sensor harness connector M146 (B) terminal 2 and front air control harness connector M49 (A) terminal 11.

**2 - 11** : Continuity should exist.

- Check continuity between intake sensor harness connector M146 terminal 6 and ground.

**2 - Ground** : Continuity should not exist.

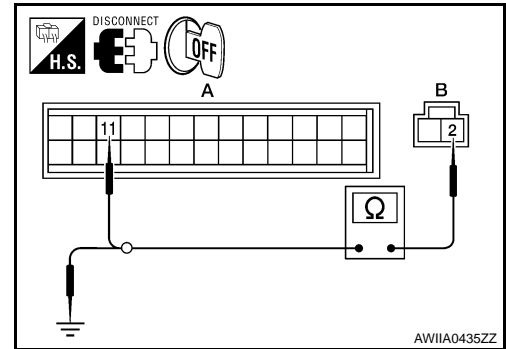

Is the inspection result normal?

- YES >> 1. Replace front air control. Refer to [VTL-8. "Removal and Installation"](#).  
 2. Go to [HAC-115. "Front Air Control Self-Diagnosis"](#) and perform self-diagnosis.
- NO >> Repair harness or connector.

## Intake Sensor Component Inspection

INFOID:000000001669173

### COMPONENT INSPECTION

Intake Sensor

After disconnecting intake sensor connector, measure resistance between terminals 1 and 2 at sensor harness side, using the table below.

Temperature °C (°F)	Resistance kΩ
-15 (5)	209.0
-10 (14)	160.0
-5 (23)	123.0
0 (32)	95.8
5 (41)	74.9
10 (50)	58.9
15 (59)	46.7
20 (68)	37.3
25 (77)	30.0
30 (86)	24.2
35 (95)	19.7
40 (104)	16.1
45 (113)	13.2

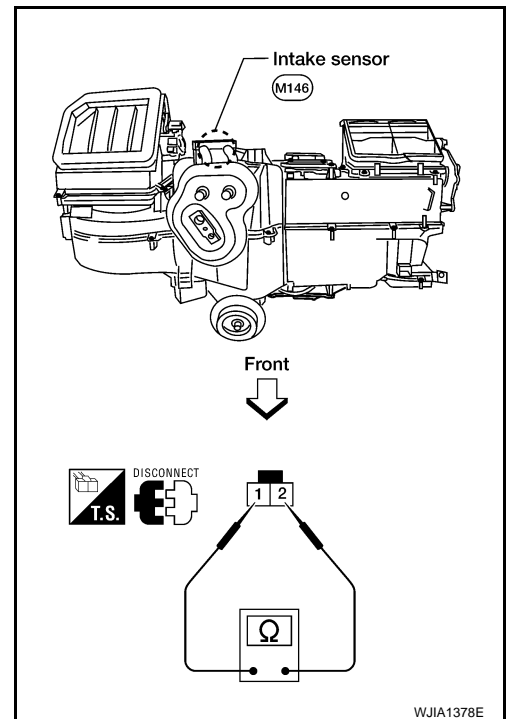

If NG, replace intake sensor. Refer to [VTL-11. "Removal and Installation"](#).



# POWER SUPPLY AND GROUND CIRCUIT FOR CONTROLLER

< COMPONENT DIAGNOSIS >

[MANUAL A/C (TYPE 1)]

## POWER SUPPLY AND GROUND CIRCUIT FOR CONTROLLER

### Component Description

INFOID:000000001669174

### COMPONENT DESCRIPTION

#### Front Air Control

The front air control has a built-in microcomputer which processes information sent from various sensors needed for air conditioner operation. The air mix door motor, mode door motor, intake door motor, defroster door motor, blower motor and A/C compressor are then controlled.

The front air control is unitized with control mechanisms. When the various switches and temperature dials are operated, data is input to the front air control.

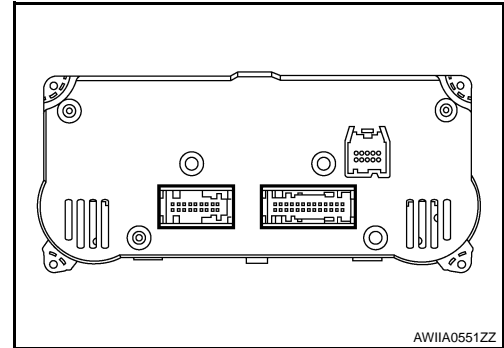

#### Potential Temperature Control (PTC)

The PTC is built into the front air control. It can be set from cold to hot or any intermediate position by rotating the temperature control dial.

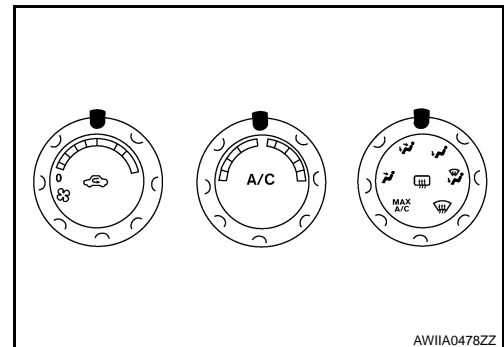

### Front Air Control Component Function Check

INFOID:000000001669175

SYMPTOM: A/C system does not come on.

#### INSPECTION FLOW

#### 1. CONFIRM SYMPTOM BY PERFORMING OPERATIONAL CHECK - AUTO MODE

1. Turn the blower control dial clockwise to low speed.
2. Press the A/C Turn the blower control dial clockwise to low speed.
3. Confirm that the compressor clutch engages (sound or visual inspection). (Discharge air and blower speed will depend on ambient, in-vehicle and set temperatures.)

#### Can a symptom be duplicated?

- YES >> GO TO 3.
- NO >> GO TO 2.

#### 2. PERFORM COMPLETE OPERATIONAL CHECK

Perform a complete operational check and check for any symptoms. Refer to [HAC-101, "Operational Check"](#).

#### Can a symptom be duplicated?

- YES >> Refer to [HAC-100, "How to Perform Trouble Diagnosis For Quick And Accurate Repair"](#).
- NO >> System OK.

#### 3. CHECK FOR SERVICE BULLETINS

Check for any service bulletins.

>> GO TO 4.

#### 4. CHECK POWER AND GROUND CIRCUIT

# POWER SUPPLY AND GROUND CIRCUIT FOR CONTROLLER

[MANUAL A/C (TYPE 1)]

## < COMPONENT DIAGNOSIS >

Check main power supply and ground circuit. Refer to [HAC-154, "Front Air Control Power and Ground Diagnosis Procedure"](#).

Is the inspection result normal?

YES >> System OK.

NO >> Replace front air control. Refer to [VTL-8, "Removal and Installation"](#).

## Front Air Control Power and Ground Diagnosis Procedure

INFOID:000000001669176

### DIAGNOSTIC PROCEDURE FOR A/C SYSTEM

SYMPTOM: A/C system does not come on.

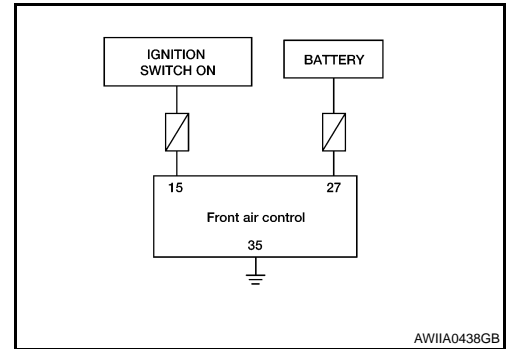

## 1. CHECK POWER SUPPLY CIRCUITS FOR FRONT AIR CONTROL

1. Disconnect front air control connectors.
2. Check voltage between front air control harness connector M49 (B) terminal 15 and M50 (A) terminal 27, and ground.

Terminals		Ignition switch position			
(+)		(-)	OFF	ACC	ON
Front air control connector	Terminal No.				
M49	15	Ground	Approx. 0V	Approx. 0V	Battery voltage
M50	27		Battery voltage	Battery voltage	Battery voltage

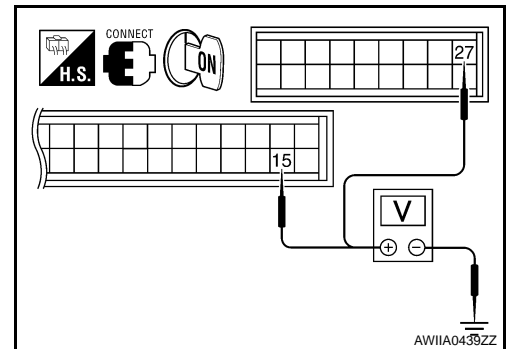

Is the inspection result normal?

YES >> GO TO 3.

NO >> Check 10A fuses [Nos. 18 and 19, located in the fuse block (J/B)]. Refer to [PG-66, "Terminal Arrangement"](#).

- If fuses are OK, check harness for open circuit. Repair or replace as necessary.
- If fuses are NG, replace fuse and check harness for short circuit. Repair or replace as necessary.

## 2. CHECK GROUND CIRCUIT FOR FRONT AIR CONTROL

1. Turn ignition switch OFF.
2. Check continuity between front air control harness connector M50 terminal 35 and ground.

**35 - Ground : Continuity should exist.**

Is the inspection result normal?

OK >> Replace front air control. Refer to [VTL-8, "Removal and Installation"](#).

NG >> Repair harness or connector.

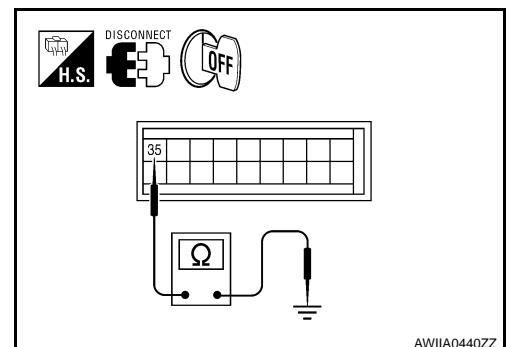

# MANUAL A/C IDENTIFICATION TABLE

< ECU DIAGNOSIS >

[MANUAL A/C (TYPE 1)]

## ECU DIAGNOSIS

### MANUAL A/C IDENTIFICATION TABLE

#### Application Table

INFOID:000000001678222

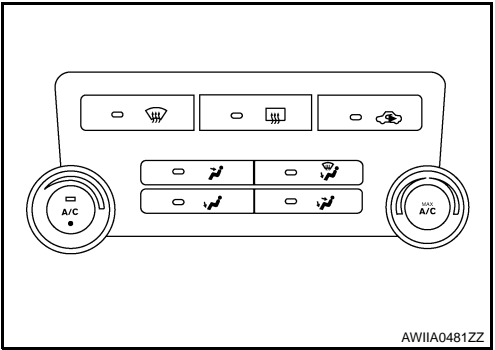
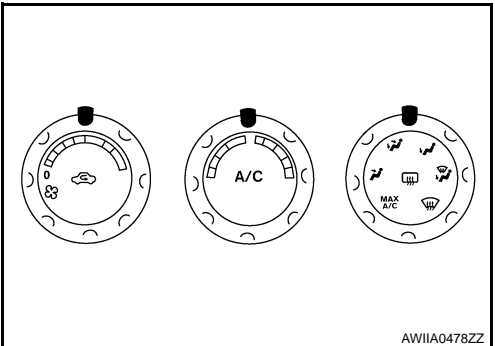
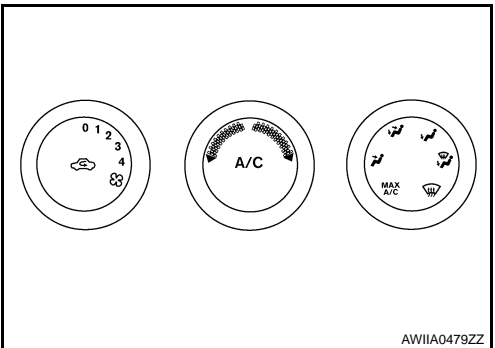
Manual A/C Type	Description	Visual Identification
Manual A/C (Type 1)	Two Control Dial System	
Manual A/C (Type 2)	Three Control Dial System [with variable blower control (VBC)]	
Manual A/C (Type 3)	Three Control Dial System [without variable blower control (VBC)]	

A  
B  
C  
D  
E  
F  
G  
H  
I  
J  
K  
L  
M  
N  
O  
P

**HAC**

# AIR CONDITIONER CONTROL

< ECU DIAGNOSIS >

[MANUAL A/C (TYPE 1)]

## AIR CONDITIONER CONTROL

### Front Air Control Terminals Reference Values

INFOID:000000001669178

Measure voltage between each terminal and ground by following Terminals and Reference Value for front air control (1).

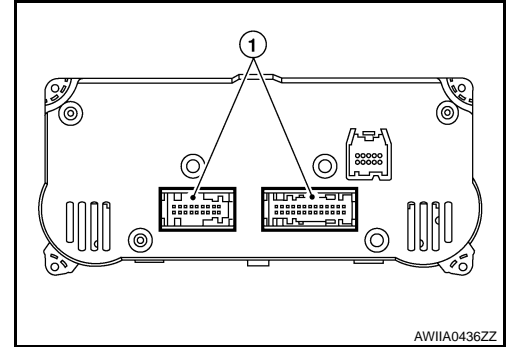

### FRONT AIR CONTROL HARNESS CONNECTOR TERMINAL LAYOUT

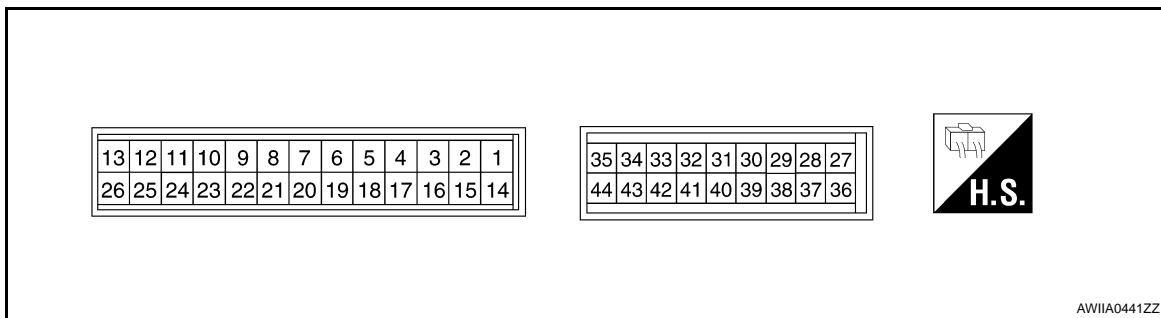

### TERMINALS AND RERERENCE VALUES FOR FRONT AIR CONTROL

Terminal No.	Wire color	Item	Ignition switch	Condition	Voltage (V) (Approx.)
3	P	V ref ACTR (ground)	ON	-	5V
4	W/R	Compressor ON signal	ON	A/C switch OFF	5V
			ON	A/C switch ON	0V
5	L/R	Fan ON signal	ON	Blower switch OFF	5V
			ON	Blower switch ON	0V
6	SB	Air mix door motor feedback	ON	-	0 - 5V
7	GR	Mode door motor feedback	ON	-	0 - 5V
8	R/L	Illumination +	ON	Park lamps ON	Battery voltage
9	BR	Illumination -	-	Park lamps ON	<p>PIIA2344E</p>
10	LG/B	Defroster door motor feedback	ON	-	0 - 5V
11	L/B	Intake sensor	ON	-	0 - 5V
13	G/R	Variable blower control	ON	-	0 - 5V
15	Y/G	Power supply for IGN	ON	-	Battery voltage
17	W/G	Air mix door motor CW	ON	Clockwise rotation	Battery voltage
18	G	Air mix door motor CCW	ON	Counterclockwise rotation	Battery voltage
19	BR/W	Mode door motor CW	ON	Clockwise rotation	Battery voltage

# AIR CONDITIONER CONTROL

< ECU DIAGNOSIS >

[MANUAL A/C (TYPE 1)]

Terminal No.	Wire color	Item	Ignition switch	Condition	Voltage (V) (Approx.)
20	P/L	Mode door motor CCW	ON	Counterclockwise rotation	Battery voltage
21	G/B	Intake door motor CCW	ON	Counterclockwise rotation	Battery voltage
22	O	Intake door motor CW	ON	Clockwise rotation	Battery voltage
23	LG	Defroster door motor CW	ON	Clockwise rotation	Battery voltage
24	P/B	Defroster door motor CCW	ON	Counterclockwise rotation	Battery voltage
25	P	Ambient sensor	ON	-	0 - 5V
26	V/R	Sensor ground	ON	-	0V
27	Y/R	Power supply for BAT	-	-	Battery voltage
28	Y	V ref ACTR (5V)	ON	-	0 - 5V
35	B	Ground	-	-	0V
36	P	CAN-L	ON	-	0 - 5V
37	L	CAN-H	ON	-	0 - 5V
41	Y/L	Water valve	ON	Water valve open	Battery voltage
				Water valve closed	0V
42	W/G	Water valve	ON	Water valve open	0V
				Water valve closed	Battery voltage

A  
B  
C  
D  
E  
F  
G  
H  
J  
K  
L  
M  
N  
O  
P

**HAC**

# AIR CONDITIONER CONTROL

< ECU DIAGNOSIS >

[MANUAL A/C (TYPE 1)]

## Wiring Diagram

INFOID:000000001669179

### AIR CONDITIONER CONTROL - MANUAL WITH 2 CONTROL DIAL SYSTEM

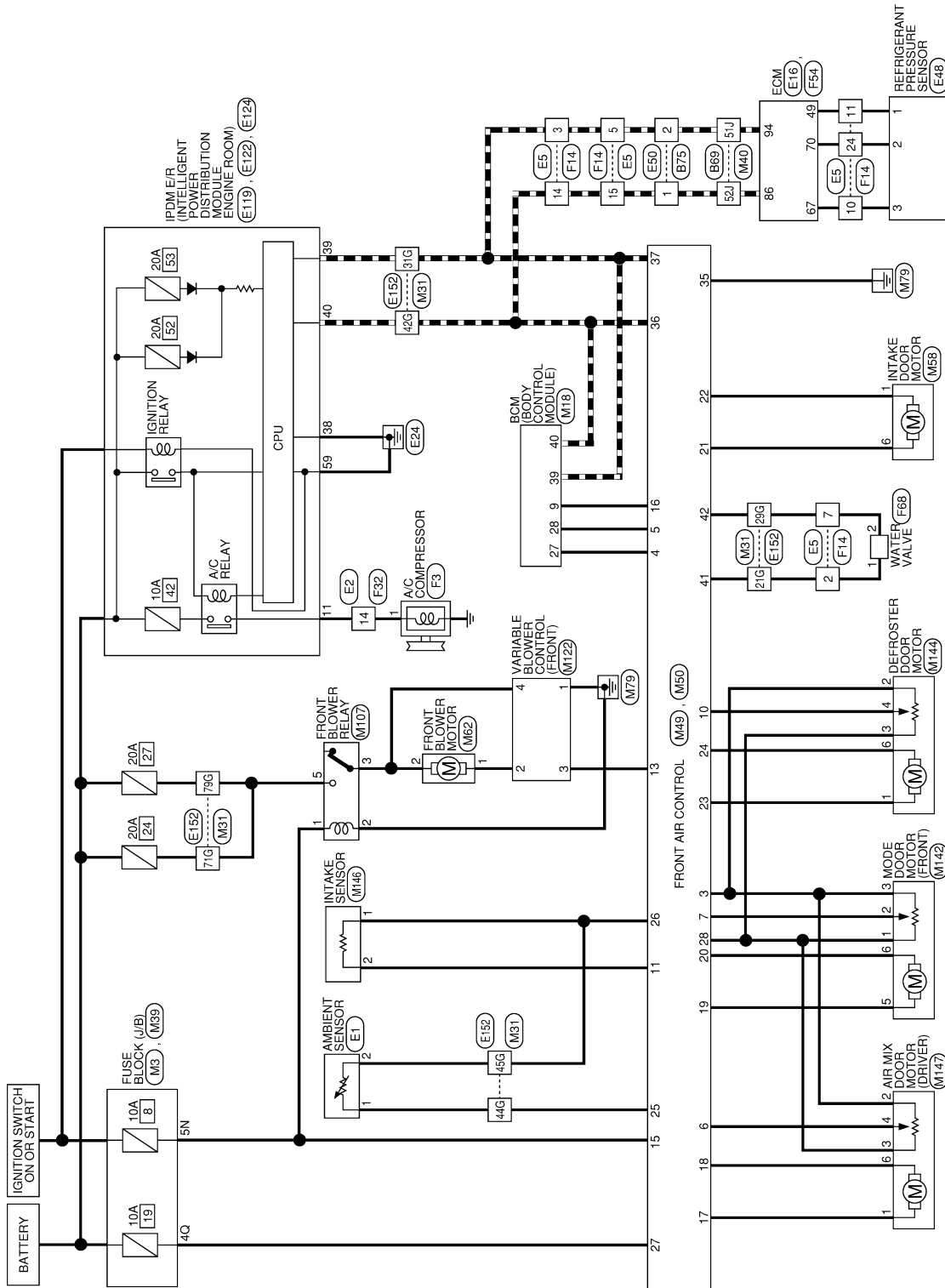

ALIWA0046GB

## AIR CONDITIONER CONTROL - MANUAL WITH 2 CONTROL DIAL SYSTEM CONNECTORS

Connector No.	M3
Connector Name	FUSE BLOCK (J/B)
Connector Color	WHITE

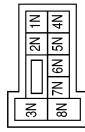

Terminal No.	Color of Wire	Signal Name
5N	Y/G	-

Connector No.	M18
Connector Name	BCM (BODY CONTROL MODULE)
Connector Color	WHITE

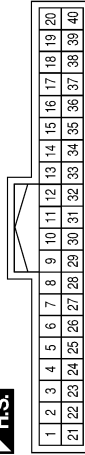

Terminal No.	Color of Wire	Signal Name
9	Y/B	RR_DEF_SW
27	W/R	AIR_CON_SW
28	L/R	BLR_FAN_SW
39	L	CAN-H
40	P	CAN-L

Connector No.	M31
Connector Name	WIRE TO WIRE
Connector Color	WHITE

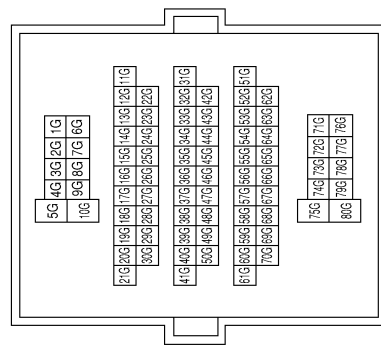

Terminal No.	Color of Wire	Signal Name
21G	Y/L	-
29G	W/G	-
31G	L	-
42G	P	-
71G	P	-
79G	P	-

Connector No.	M39
Connector Name	FUSE BLOCK (J/B)
Connector Color	WHITE

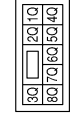

Terminal No.	Color of Wire	Signal Name
4Q	Y/R	-

ALIIA0198GB

# AIR CONDITIONER CONTROL

< ECU DIAGNOSIS >

[MANUAL A/C (TYPE 1)]

Connector No.	M40
Connector Name	WIRE TO WIRE
Connector Color	WHITE

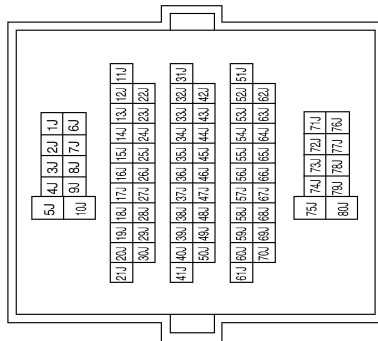

Terminal No.	Color of Wire	Signal Name
51J	L	-
52J	P	-

Connector No.	M49
Connector Name	A/C MANUAL AMP
Connector Color	BLACK

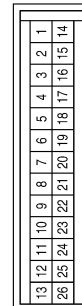

Terminal No.	Color of Wire	Signal Name
3	P	V REF RETURN
4	W/R	AC REQUEST
5	L/R	FAN ON
6	SB	DR BLEND DR FEED BACK
7	GR	FLOOR FEEDBACK
10	LG/B	PANEL DEFROST FEED BACK

Terminal No.	Color of Wire	Signal Name
11	L/B	EVAP AIR TEMP SENS
13	G/R	VBC SIG PWR
15	Y/G	IGN
16	Y/B	RR DEF REQUEST
17	W/G	DR BLEND DOOR A
18	G	DR BLEND DOOR B
19	BR/W	FLOOR A
20	P/L	FLOOR B
21	G/B	RECIRC DOOR A
22	O	RECIRC DOOR B
23	LG	PANEL DEFROST A
24	P/B	PANEL DEFROST B
25	P	AMB TEMP SENS
26	V/R	SENS RETURN

Connector No.	M50
Connector Name	A/C MANUAL AMP
Connector Color	BLUE

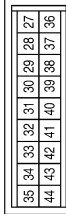

Terminal No.	Color of Wire	Signal Name
27	Y/R	B
28	Y	V REF ACTR (5V)
35	B	GND
36	P	CAN L
37	L	CAN H
41	Y/L	WATER VALVE CLOSE
42	W/G	WATER VALVE OPEN

ALIIA0199GB



# AIR CONDITIONER CONTROL

< ECU DIAGNOSIS >

[MANUAL A/C (TYPE 1)]

Connector No.	M107
Connector Name	FRONT BLOWER RELAY
Connector Color	BLACK

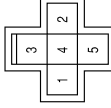

Terminal No.	Color of Wire	Signal Name
1	Y/G	-
2	B	-
3	W/L	-
5	GR	-

Connector No.	M62
Connector Name	FRONT BLOWER MOTOR
Connector Color	BLACK



Terminal No.	Color of Wire	Signal Name
1	L/W	-
2	W/L	-

Connector No.	M58
Connector Name	INTAKE DOOR MOTOR
Connector Color	BLACK

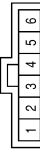

Terminal No.	Color of Wire	Signal Name
1	O	-
6	G/B	-

Connector No.	M144
Connector Name	DEFROSTER DOOR MOTOR
Connector Color	BLACK

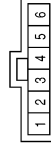

Terminal No.	Color of Wire	Signal Name
1	LG	-
2	P	-
3	Y	-
4	LG/B	-
6	P/B	-

Connector No.	M142
Connector Name	MODE DOOR MOTOR (FRONT)
Connector Color	BLACK

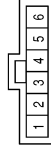

Terminal No.	Color of Wire	Signal Name
1	P	-
2	GR	-
3	Y	-
5	BR/W	-
6	P/L	-

Connector No.	M122
Connector Name	VARIABLE BLOWER CONTROL (FRONT)
Connector Color	WHITE

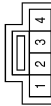

Terminal No.	Color of Wire	Signal Name
1	W/L	-
2	G/R	-
3	L/W	-
4	B/W	-

ALIIA0200GB

A  
B  
C  
D  
E  
F  
G  
H  
HAC  
J  
K  
L  
M  
N  
O  
P

# AIR CONDITIONER CONTROL

< ECU DIAGNOSIS >

[MANUAL A/C (TYPE 1)]

Connector No.	M146
Connector Name	INTAKE SENSOR
Connector Color	GRAY



Terminal No.	Color of Wire	Signal Name
1	V/R	-
2	L/B	-

Connector No.	M147
Connector Name	AIR MIX DOOR MOTOR (DRIVER)
Connector Color	BLACK



Terminal No.	Color of Wire	Signal Name
1	W/G	-
2	P	-
3	Y	-
4	SB	-
6	G	-

Connector No.	E1
Connector Name	AMBIENT SENSOR
Connector Color	GRAY



Terminal No.	Color of Wire	Signal Name
1	P	-
2	V/R	-

Connector No.	E2
Connector Name	WIRE TO WIRE
Connector Color	WHITE

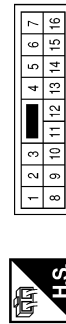

Terminal No.	Color of Wire	Signal Name
14	Y/B	-

Connector No.	E5
Connector Name	WIRE TO WIRE
Connector Color	WHITE

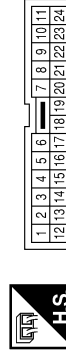

Terminal No.	Color of Wire	Signal Name
2	Y/L	-
3	L	-
5	L	-
7	W/G	-
14	P	-
15	P	-

Connector No.	E16
Connector Name	ECM
Connector Color	BLACK

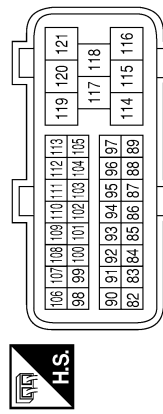

Terminal No.	Color of Wire	Signal Name
86	P	CAN-L
94	L	CAN-H

# AIR CONDITIONER CONTROL

< ECU DIAGNOSIS >

[MANUAL A/C (TYPE 1)]

Connector No.	E50
Connector Name	WIRE TO WIRE
Connector Color	BROWN



Terminal No.	Color of Wire	Signal Name
1	P	—
2	L	—

Connector No.	E119
Connector Name	IPDM E/R (INTELLIGENT POWER DISTRIBUTION MODULE ENGINE ROOM)
Connector Color	WHITE

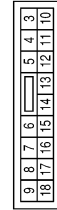

Terminal No.	Color of Wire	Signal Name
11	Y/B	AC_COMP

Connector No.	E122
Connector Name	IPDM E/R (INTELLIGENT POWER DISTRIBUTION MODULE ENGINE ROOM)
Connector Color	WHITE

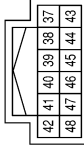

Terminal No.	Color of Wire	Signal Name
38	B	GND (SIG)
39	L	CAN-H
40	P	CAN-L

Connector No.	E124
Connector Name	IPDM E/R (INTELLIGENT POWER DISTRIBUTION MODULE ENGINE ROOM)
Connector Color	BLACK



Terminal No.	Color of Wire	Signal Name
59	B	GND (PWR)

Connector No.	E152
Connector Name	WIRE TO WIRE
Connector Color	WHITE

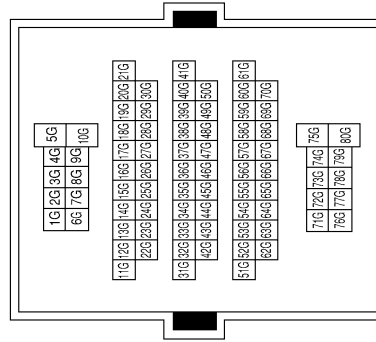

Terminal No.	Color of Wire	Signal Name
21G	Y/L	—
29G	W/G	—
31G	L	—
42G	P	—
71G	P	—
79G	GR	—

A  
B  
C  
D  
E  
F  
G  
H  
HAC  
J  
K  
L  
M  
N  
O  
P

# AIR CONDITIONER CONTROL

< ECU DIAGNOSIS >

[MANUAL A/C (TYPE 1)]

Connector No.	F3
Connector Name	A/C COMPRESSOR
Connector Color	BLACK



Terminal No.	Color of Wire	Signal Name
1	Y/B	-

Connector No.	F14
Connector Name	WIRE TO WIRE
Connector Color	WHITE

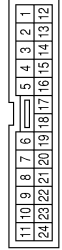

Terminal No.	Color of Wire	Signal Name
2	Y/L	-
3	L	-
5	L	-
7	W/G	-
14	P	-
15	P	-

Connector No.	F32
Connector Name	WIRE TO WIRE
Connector Color	WHITE

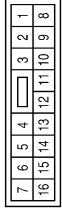

Terminal No.	Color of Wire	Signal Name
14	Y/B	-

Connector No.	F68
Connector Name	WATER VALVE
Connector Color	GRAY



Terminal No.	Color of Wire	Signal Name
1	Y/L	-
2	W/G	-

Connector No.	B69
Connector Name	WIRE TO WIRE
Connector Color	WHITE

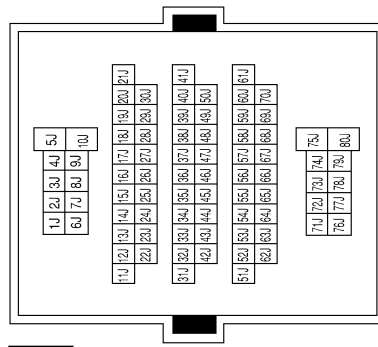

Terminal No.	Color of Wire	Signal Name
51J	L	-
52J	P	-

Connector No.	B75
Connector Name	WIRE TO WIRE
Connector Color	BROWN



Terminal No.	Color of Wire	Signal Name
1	P	-
2	L	-

ALIIA0203GB

# MANUAL A/C IDENTIFICATION TABLE

< SYMPTOM DIAGNOSIS >

[MANUAL A/C (TYPE 1)]

## SYMPTOM DIAGNOSIS

### MANUAL A/C IDENTIFICATION TABLE

#### Application Table

INFOID:000000001677677

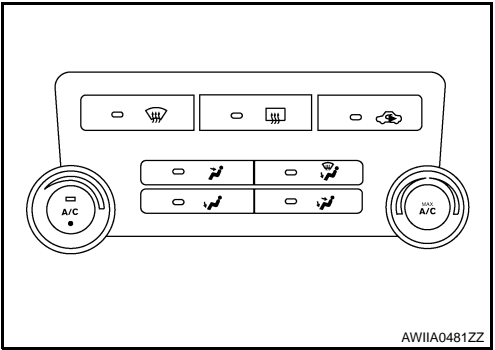
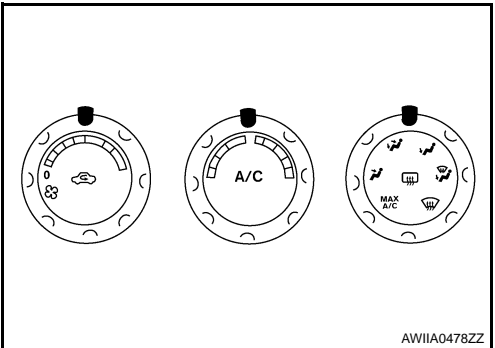
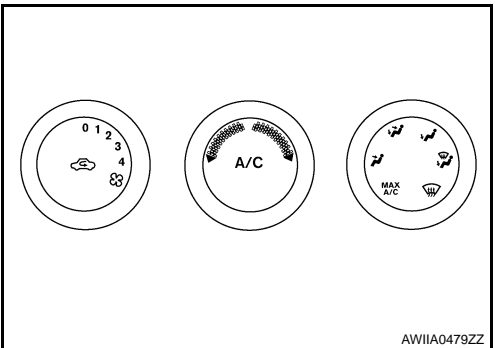
Manual A/C Type	Description	Visual Identification
Manual A/C (Type 1)	Two Control Dial System	
Manual A/C (Type 2)	Three Control Dial System [with variable blower control (VBC)]	
Manual A/C (Type 3)	Three Control Dial System [without variable blower control (VBC)]	

A  
B  
C  
D  
E  
F  
G  
H  
I  
J  
K  
L  
M  
N  
O  
P

**HAC**

# AIR CONDITIONER CONTROL

< SYMPTOM DIAGNOSIS >

[MANUAL A/C (TYPE 1)]

## AIR CONDITIONER CONTROL

### Symptom Matrix Chart

INFOID:000000001669180

#### SYMPTOM TABLE

Symptom	Reference Page
A/C system does not come on.	Go to Trouble Diagnosis Procedure for A/C System. <a href="#">HAC-153</a>
A/C system cannot be controlled.	Go to Self-diagnosis Function. <a href="#">HAC-115</a>
Air outlet does not change.	Go to Trouble Diagnosis Procedure for Mode Door Motor. <a href="#">HAC-117</a>
Mode door motor is malfunctioning.	
Discharge air temperature does not change.	Go to Trouble Diagnosis Procedure for Air Mix Door Motor. <a href="#">HAC-122</a>
Air mix door motor is malfunctioning.	
Intake door does not change.	Go to Trouble Diagnosis Procedure for Intake Door Motor. <a href="#">HAC-127</a>
Intake door motor is malfunctioning.	
Defroster door motor is malfunctioning.	Go to Trouble Diagnosis Procedure for Defroster Door Motor. <a href="#">HAC-130</a>
Front blower motor operation is malfunctioning.	Go to Trouble Diagnosis Procedure for Front Blower Motor. <a href="#">HAC-135</a>
Magnet clutch does not engage.	Go to Trouble Diagnosis Procedure for Magnet Clutch. <a href="#">HAC-141</a>
Insufficient cooling	Go to Trouble Diagnosis Procedure for Insufficient Cooling. <a href="#">HAC-167</a>
Insufficient heating	Go to Trouble Diagnosis Procedure for Insufficient Heating. <a href="#">HAC-175</a>
Noise	Go to Trouble Diagnosis Procedure for Noise. <a href="#">HAC-177</a>
Self-diagnosis cannot be performed.	Go to Trouble Diagnosis Procedure for Self-diagnosis. XXXX <a href="#">HAC-70</a>

## INSUFFICIENT COOLING

## Component Function Check

INFOID:000000001669181

SYMPTOM: Insufficient cooling

## INSPECTION FLOW

**1. CONFIRM SYMPTOM BY PERFORMING OPERATIONAL CHECK - TEMPERATURE DECREASE**

1. Rotate the blower control dial to the low speed.
2. Turn temperature control dial counterclockwise to maximum cold.
3. Check for cold air at discharge air outlets.

Can the symptom be duplicated?

YES &gt;&gt; GO TO 3.

NO &gt;&gt; GO TO 2.

**2. CHECK FOR ANY SYMPTOMS**Perform a complete operational check for any symptoms. Refer to [HAC-101, "Operational Check"](#).Does another symptom exist?YES >> Refer to [HAC-166, "Symptom Matrix Chart"](#).

NO &gt;&gt; System OK.

**3. CHECK FOR SERVICE BULLETINS**

Check for any service bulletins.

&gt;&gt; If equipped with NAVI, GO TO 4.

&gt;&gt; If not equipped with NAVI, GO TO 5.

**4. PERFORM SELF-DIAGNOSIS**Perform self-diagnosis Refer to [HAC-115, "Front Air Control Self-Diagnosis"](#).Is the inspection result normal?

YES &gt;&gt; GO TO 5.

NO >> Refer to [HAC-166, "Symptom Matrix Chart"](#).**5. CHECK DRIVE BELTS**Check compressor belt tension. Refer to [EM-12, "Checking Drive Belts"](#).Is the inspection result normal?

OK &gt;&gt; GO TO 6.

NG >> Adjust or replace compressor belt. Refer to [EM-12, "Removal and Installation"](#).**6. CHECK AIR MIX DOOR OPERATION**Check and verify air mix door mechanism for smooth operation. Refer to [HAC-122, "Air Mix Door Motor Component Function Check"](#)Does air mix door operate correctly?

YES &gt;&gt; GO TO 7.

NO >> Check air mix door motor circuit. Refer to [HAC-123, "Air Mix Door Motor Diagnosis Procedure"](#).**7. CHECK COOLING FAN MOTOR OPERATION**Check and verify cooling fan motor for smooth operation. Refer to [EC-305, "Overall Function Check"](#).Does cooling fan motor operate correctly?

YES &gt;&gt; GO TO 8.

NO >> Check cooling fan motor. Refer to [EC-306, "Diagnosis Procedure"](#).**8. CHECK WATER VALVE OPERATION**Check and verify water valve for smooth operation. Refer to [HAC-146, "Description"](#).Does water valve operate correctly?

YES &gt;&gt; GO TO 9.

# INSUFFICIENT COOLING

< SYMPTOM DIAGNOSIS >

[MANUAL A/C (TYPE 1)]

NO >> Check water valve circuit. Refer to [HAC-146. "Water Valve Diagnosis Procedure"](#).

## 9.CHECK RECOVERY/RECYCLING EQUIPMENT BEFORE USAGE

Check recovery/recycling equipment before connecting to vehicle. Verify there is no pressure in the recovery/recycling equipment by checking the gauges. If pressure exists, recover refrigerant from equipment lines.

>> GO TO 10.

## 10.CHECK REFRIGERANT PURITY

1. Connect recovery/recycling equipment to vehicle.
2. Confirm refrigerant purity in supply tank using recovery/recycling and refrigerant identifier.

Is the inspection result normal?

YES >> GO TO 11.

NO >> Check contaminated refrigerant. Refer to [HAC-179. "Working with HFC-134a \(R-134a\)"](#).

## 11.CHECK FOR EVAPORATOR FREEZE UP

Start engine and run A/C. Check for evaporator freeze up.

Does evaporator freeze up?

YES >> Perform performance test diagnoses. Refer to [HAC-168. "Performance Test Diagnoses"](#).

NO >> GO TO 12.

## 12.CHECK REFRIGERANT PRESSURE

Check refrigerant pressure with manifold gauge connected. Refer to [HAC-171. "Test Reading"](#).

Is the inspection result normal?

YES >> Perform performance test diagnoses. Refer to [HAC-168. "Performance Test Diagnoses"](#).

NO >> GO TO 13.

## 13.CHECK AIR DUCTS

Check ducts for air leaks.

Is the inspection result normal?

YES >> System OK.

NO >> Repair air leaks.

Performance Test Diagnoses

INFOID:000000001669182



# INSUFFICIENT COOLING

< SYMPTOM DIAGNOSIS >

[MANUAL A/C (TYPE 1)]

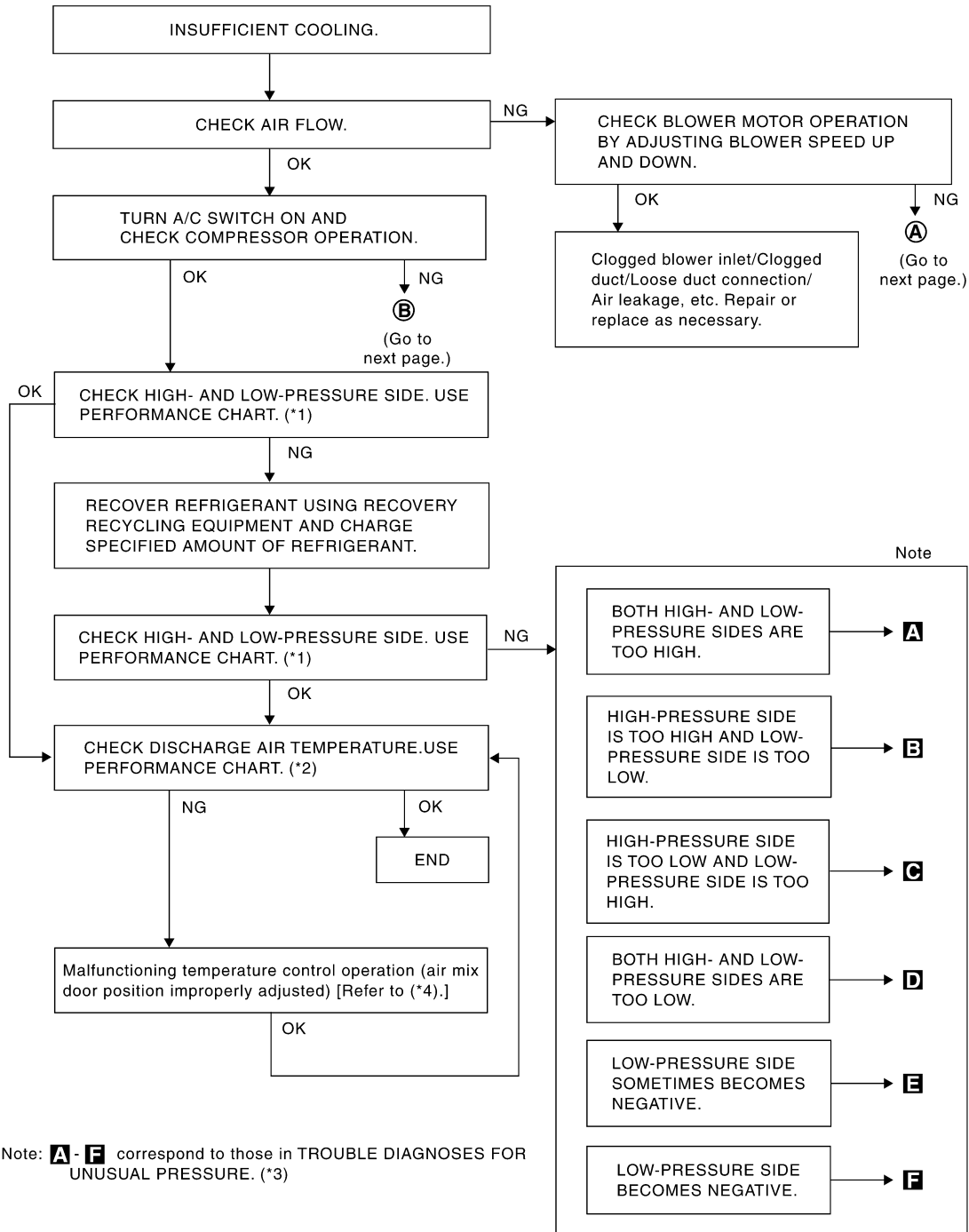

RJA1601E

\*1 [HAC-170. "Performance Chart"](#)

\*2 [HAC-171. "Test Reading"](#)

\*3 [HAC-172. "Trouble Diagnoses for Unusual Pressure"](#)

\*4 [HAC-122. "Air Mix Door Motor Component Function Check"](#)

A  
B  
C  
D  
E  
F  
G  
H  
HAC  
J  
K  
L  
M  
N  
O  
P

# INSUFFICIENT COOLING

< SYMPTOM DIAGNOSIS >

[MANUAL A/C (TYPE 1)]

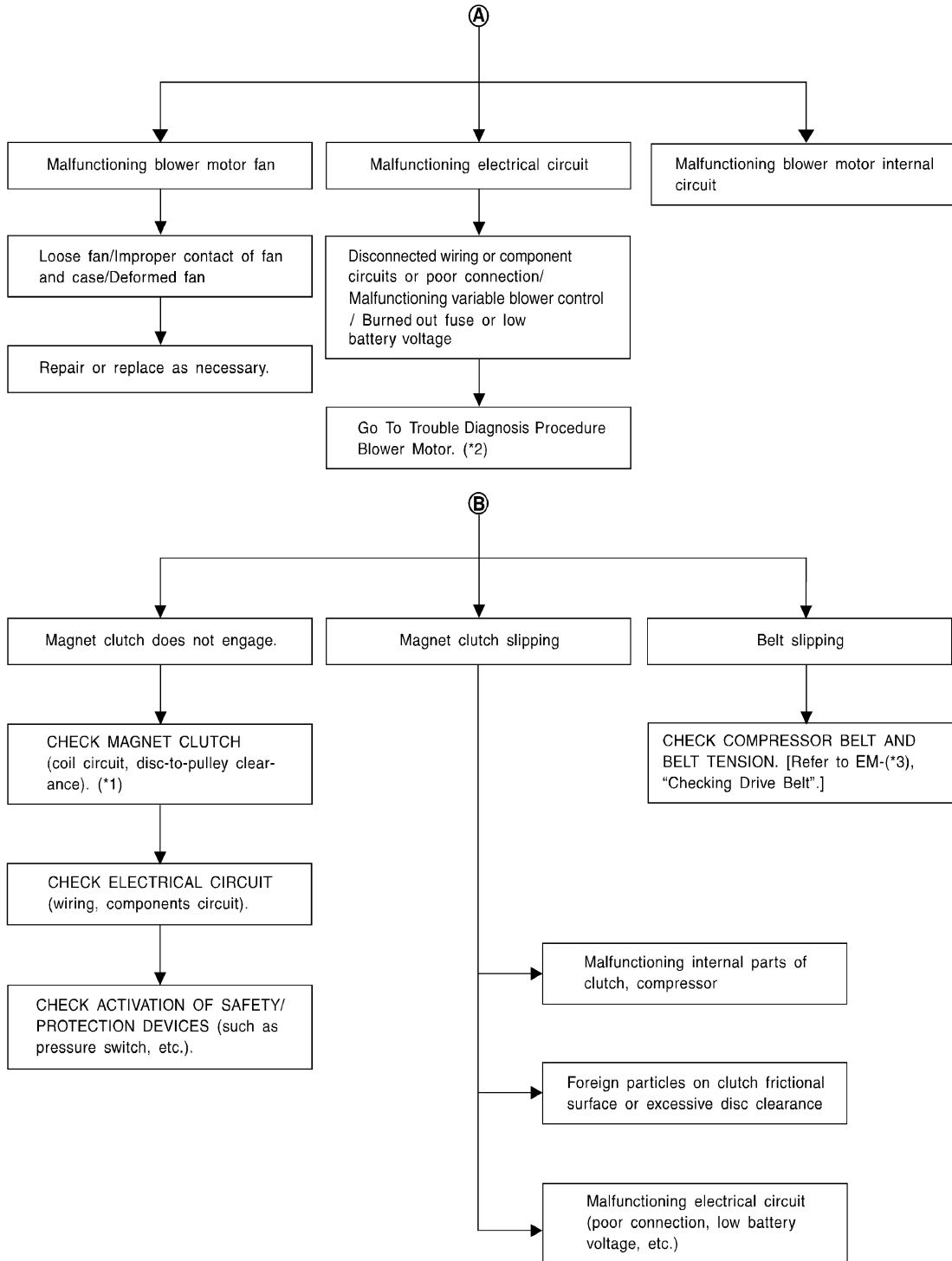

WJIA1371E

\*1 [HA-34. "Removal and Installation for Compressor Clutch"](#)

\*2 [HAC-135. "Front Blower Motor Component Function Check"](#)

\*3 [EM-12. "Checking Drive Belts"](#)

## Performance Chart

INFOID:000000001669183

Test Condition



HAC-170

# INSUFFICIENT COOLING

< SYMPTOM DIAGNOSIS >

[MANUAL A/C (TYPE 1)]

Testing must be performed as follows:

Vehicle location	Indoors or in the shade (in a well-ventilated place)
Doors	Closed
Door window	Open
Hood	Open
TEMP.	Max. COLD
Mode switch	 (Ventilation) set
Recirculation (REC) switch	 (Recirculation) set
 Blower speed	Max. speed set
Engine speed	Idle speed

Operate the air conditioning system for 10 minutes before taking measurements.

## Test Reading

INFOID:000000001669184

### Recirculating-to-discharge Air Temperature Table

Inside air (Recirculating air) at blower assembly inlet		Discharge air temperature at center ventilator °C (°F)
Relative humidity %	Air temperature °C (°F)	
50 - 60	20 (68)	9.9 - 13.9 (50 - 57)
	25 (77)	14.6 - 18.6 (58 - 65)
	30 (86)	16.8 - 21.8 (62 - 71)
	35 (95)	21.1 - 27.1 (70 - 81)
	40 (104)	25.3 - 31.5 (78 - 89)
60 - 70	20 (68)	11.4 - 15.2 (53 - 59)
	25 (77)	15.5 - 20.0 (60 - 68)
	30 (86)	19.9 - 25.0 (68 - 77)
	35 (95)	24.5 - 29.6 (76 - 85)
	40 (104)	28.7 - 34.9 (84 - 95)

### Ambient Air Temperature-to-operating Pressure Table

Ambient air		High-pressure (Discharge side) kPa (kg/cm <sup>2</sup> , psi)	Low-pressure (Suction side) kPa (kg/cm <sup>2</sup> , psi)
Relative humidity %	Air temperature °C (°F)		
50 - 70	20 (68)	1020 - 1250 (10.4 - 12.7, 147.9 - 181.3)	160 - 190 (1.63 - 1.94, 23.2 - 27.6)
	25 (77)	1236 - 1510 (12.6 - 15.4, 179.2 - 219)	206 - 245 (2.1 - 2.5, 29.9 - 35.6)
	30 (86)	1569 - 1,922 (16.0 - 19.6, 227.6 - 278.8)	265 - 324 (2.7 - 3.3, 38.4 - 46.9)
	35 (95)	1,697 - 2079 (17.3 - 21.2, 246.1 - 301.5)	304 - 363 (3.1 - 3.7, 44.1 - 52.6)
	40 (104)	1971 - 2403 (20.1 - 24.5, 285.9 - 348.5)	373 - 451 (3.8 - 4.6, 54.0 - 65.4)

# INSUFFICIENT COOLING

< SYMPTOM DIAGNOSIS >

[MANUAL A/C (TYPE 1)]

## Trouble Diagnoses for Unusual Pressure

INFOID:000000001669185

Whenever system's high and/or low side pressure is unusual, diagnose using a manifold gauge. The marker above the gauge scale in the following tables indicates the standard (usual) pressure range. Since the standard (usual) pressure, however, differs from vehicle to vehicle, refer to above table (Ambient air temperature-to-operating pressure table).

### Both High- and Low-pressure Sides are Too High

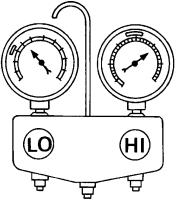
Gauge indication	Refrigerant cycle	Probable cause	Corrective action
<p>Both high- and low-pressure sides are too high.</p>  <p>AC359A</p>	Pressure is reduced soon after water is splashed on condenser.	Excessive refrigerant charge in refrigeration cycle	Reduce refrigerant until specified pressure is obtained.
	Air suction by cooling fan is insufficient.	Insufficient condenser cooling performance ↓ 1. Condenser fins are clogged. 2. Improper fan rotation of cooling fan	<ul style="list-style-type: none"> <li>Clean condenser.</li> <li>Check and repair cooling fan if necessary.</li> </ul>
	<ul style="list-style-type: none"> <li>Low-pressure pipe is not cold.</li> <li>When compressor is stopped high-pressure value quickly drops by approximately 196 kPa (2 kg/cm<sup>2</sup>, 28 psi). It then decreases gradually thereafter.</li> </ul>	Poor heat exchange in condenser (After compressor operation stops, high-pressure decreases too slowly.) ↓ Air in refrigeration cycle	Evacuate and recharge system.
	Engine tends to overheat.	Engine cooling systems malfunction.	Check and repair engine cooling system.
	<ul style="list-style-type: none"> <li>An area of the low-pressure pipe is colder than areas near the evaporator outlet.</li> <li>Plates are sometimes covered with frost.</li> </ul>	<ul style="list-style-type: none"> <li>Excessive liquid refrigerant on low-pressure side</li> <li>Excessive refrigerant discharge flow</li> <li>Expansion valve is open a little compared with the specification.</li> </ul> ↓ Improper expansion valve adjustment	Replace expansion valve.

### High-pressure Side is Too High and Low-pressure Side is Too Low

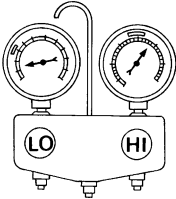
Gauge indication	Refrigerant cycle	Probable cause	Corrective action
<p>High-pressure side is too high and low-pressure side is too low.</p>  <p>AC360A</p>	Upper side of condenser and high-pressure side are hot, however, liquid tank is not so hot.	High-pressure tube or parts located between compressor and condenser are clogged or crushed.	<ul style="list-style-type: none"> <li>Check and repair or replace malfunctioning parts.</li> <li>Check oil for contamination.</li> </ul>

### High-pressure Side is Too Low and Low-pressure Side is Too High

# INSUFFICIENT COOLING

< SYMPTOM DIAGNOSIS >

[MANUAL A/C (TYPE 1)]

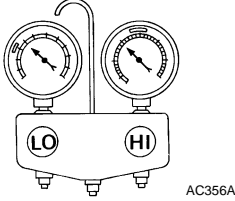
Gauge indication	Refrigerant cycle	Probable cause	Corrective action
High-pressure side is too low and low-pressure side is too high.  	High- and low-pressure sides become equal soon after compressor operation stops.	Compressor pressure operation is improper. ↓ Damaged inside compressor packings.	Replace compressor.
	No temperature difference between high- and low-pressure sides.	Compressor pressure operation is improper. ↓ Damaged inside compressor packings.	Replace compressor.

A  
B  
C  
D

## Both High- and Low-pressure Sides are Too Low

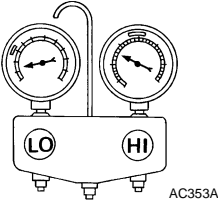
Gauge indication	Refrigerant cycle	Probable cause	Corrective action
Both high- and low-pressure sides are too low.  	<ul style="list-style-type: none"> <li>There is a big temperature difference between liquid tank outlet and inlet. Outlet temperature is extremely low.</li> <li>Liquid tank inlet and expansion valve are frosted.</li> </ul>	Liquid tank inside is slightly clogged.	<ul style="list-style-type: none"> <li>Replace liquid tank.</li> <li>Check oil for contamination.</li> </ul>
	<ul style="list-style-type: none"> <li>Temperature of expansion valve inlet is extremely low as compared with areas near liquid tank.</li> <li>Expansion valve inlet may be frosted.</li> <li>Temperature difference occurs somewhere in high-pressure side.</li> </ul>	High-pressure pipe located between liquid tank and expansion valve is clogged.	<ul style="list-style-type: none"> <li>Check and repair malfunctioning parts.</li> <li>Check oil for contamination.</li> </ul>
	Expansion valve and liquid tank are warm or only cool when touched.	Low refrigerant charge. ↓ Leaking fittings or components.	Check refrigerant system for leaks. Refer to <a href="#">HA-23, "Checking of Refrigerant Leaks"</a> .
	There is a big temperature difference between expansion valve inlet and outlet while the valve itself is frosted.	Expansion valve closes a little compared with the specification. ↓ 1. Improper expansion valve adjustment. 2. Malfunctioning expansion valve. 3. Outlet and inlet may be clogged.	<ul style="list-style-type: none"> <li>Remove foreign particles by using compressed air.</li> <li>Check oil for contamination.</li> </ul>
	An area of the low-pressure pipe is colder than areas near the evaporator outlet.	Low-pressure pipe is clogged or crushed.	<ul style="list-style-type: none"> <li>Check and repair malfunctioning parts.</li> <li>Check oil for contamination.</li> </ul>
	Air flow volume is too low.	Evaporator is frozen.	<ul style="list-style-type: none"> <li>Check intake sensor circuit. Refer to <a href="#">HAC-151, "Intake Sensor Diagnosis Procedure"</a>.</li> <li>Repair evaporator fins.</li> <li>Replace evaporator.</li> <li>Refer to <a href="#">HAC-135, "Front Blower Motor Component Function Check"</a>.</li> </ul>

E  
F  
G  
H  
J  
K  
L  
M  
N  
O  
P

HAC

Low-pressure Side Sometimes Becomes Negative

# INSUFFICIENT COOLING

< SYMPTOM DIAGNOSIS >

[MANUAL A/C (TYPE 1)]

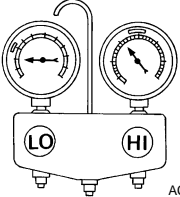
Gauge indication	Refrigerant cycle	Probable cause	Corrective action
<p>Low-pressure side sometimes becomes negative.</p>  <p style="text-align: right; font-size: small;">AC354A</p>	<ul style="list-style-type: none"> <li>• Air conditioning system does not function and does not cyclically cool the compartment air.</li> <li>• The system constantly functions for a certain period of time after compressor is stopped and restarted.</li> </ul>	<p>Refrigerant does not discharge cyclically.</p> <p>↓</p> <p>Moisture is frozen at expansion valve outlet and inlet.</p> <p>↓</p> <p>Water is mixed with refrigerant.</p>	<ul style="list-style-type: none"> <li>• Drain water from refrigerant or replace refrigerant.</li> <li>• Replace liquid tank.</li> </ul>

## Low-pressure Side Becomes Negative

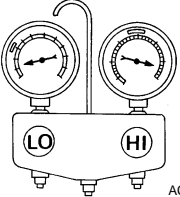
Gauge indication	Refrigerant cycle	Probable cause	Corrective action
<p>Low-pressure side becomes negative.</p>  <p style="text-align: right; font-size: small;">AC362A</p>	<p>Liquid tank or front/rear side of expansion valve's pipe is frosted or dewed.</p>	<p>High-pressure side is closed and refrigerant does not flow.</p> <p>↓</p> <p>Expansion valve or liquid tank is frosted.</p>	<p>Leave the system at rest until no frost is present. Start it again to check whether or not the malfunction is caused by water or foreign particles.</p> <ul style="list-style-type: none"> <li>• If water is the cause, initially cooling is okay. Then the water freezes causing a blockage. Drain water from refrigerant or replace refrigerant.</li> <li>• If due to foreign particles, remove expansion valve and remove the particles with dry and compressed air (not shop air).</li> <li>• If either of the above methods cannot correct the malfunction, replace expansion valve.</li> <li>• Replace liquid tank.</li> <li>• Check oil for contamination.</li> </ul>

**INSUFFICIENT HEATING****Component Function Check**

INFOID:000000001669186

SYMPTOM: Insufficient heating

**INSPECTION FLOW****1. CONFIRM SYMPTOM BY PERFORMING OPERATIONAL CHECK - TEMPERATURE INCREASE**

1. Turn the blower control dial to low speed.
2. Turn the temperature control dial clockwise to maximum heat
3. Check for hot air at discharge air outlets.

Can this symptom be duplicated?

YES &gt;&gt; GO TO 2.

NO >> Perform complete system operational check. Refer to [HAC-101, "Operational Check"](#).**2. CHECK FOR SERVICE BULLETINS**

Check for any service bulletins.

&gt;&gt; If equipped with NAVI, GO TO 3.

&gt;&gt; If not equipped with NAVI, GO TO 4.

**3. PERFORM SELF-DIAGNOSIS**Perform self-diagnosis. Refer to [HAC-115, "Front Air Control Self-Diagnosis"](#).Is the inspection results normal?

YES &gt;&gt; GO TO 4.

NO >> Refer to [HAC-166, "Symptom Matrix Chart"](#).**4. CHECK ENGINE COOLING SYSTEM**

1. Check for proper engine coolant level. Refer to [CO-10, "Inspection"](#).
2. Check hoses for leaks or kinks.
3. Check radiator cap. Refer to [CO-10, "Inspection"](#).
4. Check for air in cooling system.

&gt;&gt; GO TO 5.

**5. CHECK AIR MIX DOOR OPERATION**

Check the operation of the air mix door.

Is the inspection result normal?

YES &gt;&gt; GO TO 6.

NO >> Check the air mix door motor circuit. Refer to [HAC-122, "Air Mix Door Motor Component Function Check"](#).**6. CHECK AIR DUCTS**

Check for disconnected or leaking air ducts.

Is the inspection result normal?

YES &gt;&gt; GO TO 7.

NO &gt;&gt; Repair all disconnected or leaking air ducts.

**7. CHECK HEATER HOSE TEMPERATURES**

1. Start engine and warm it up to normal operating temperature.
2. Touch both the inlet and outlet heater hoses.

Is the inspection result normal?

YES &gt;&gt; Hot inlet hose and a warm outlet hose: GO TO 8.

NO >> • Inlet hose cold: GO TO 11.  
• Both hoses warm: GO TO 9.**8. CHECK ENGINE COOLANT SYSTEM**

## INSUFFICIENT HEATING

< SYMPTOM DIAGNOSIS >

[MANUAL A/C (TYPE 1)]

Check engine control temperature sensor. Refer to [EC-126, "Component Inspection"](#).

Is the inspection result normal?

YES >> System OK.

NO >> Repair or replace as necessary. Retest.

### 9.CHECK HEATER HOSES

---

Check heater hoses for proper installation.

Is the inspection result normal?

YES >> System OK.

NO >> 1. Back flush heater core.

2. Drain the water from the system.

3. Refill system with new engine coolant. Refer to [CO-11, "Changing Engine Coolant"](#).

4. GO TO 11 to retest.

### 10.CHECK HEATER HOSE TEMPERATURES

---

1. Start engine and warm it up to normal operating temperature.

2. Touch both the inlet and outlet heater hoses.

Is the inspection result normal?

YES >> System OK.

NO >> Replace heater core. Refer to [VTL-15, "Removal and Installation"](#).

### 11.CHECK WATER VALVE

---

Check the operation of the water valve. Refer to [HAC-146, "Water Valve Diagnosis Procedure"](#).

Is the inspection result normal?

YES >> System OK.

NO >> Replace water valve.



NOISE

Component Function Check

INFOID:000000001669187

SYMPTOM: Noise

INSPECTION FLOW

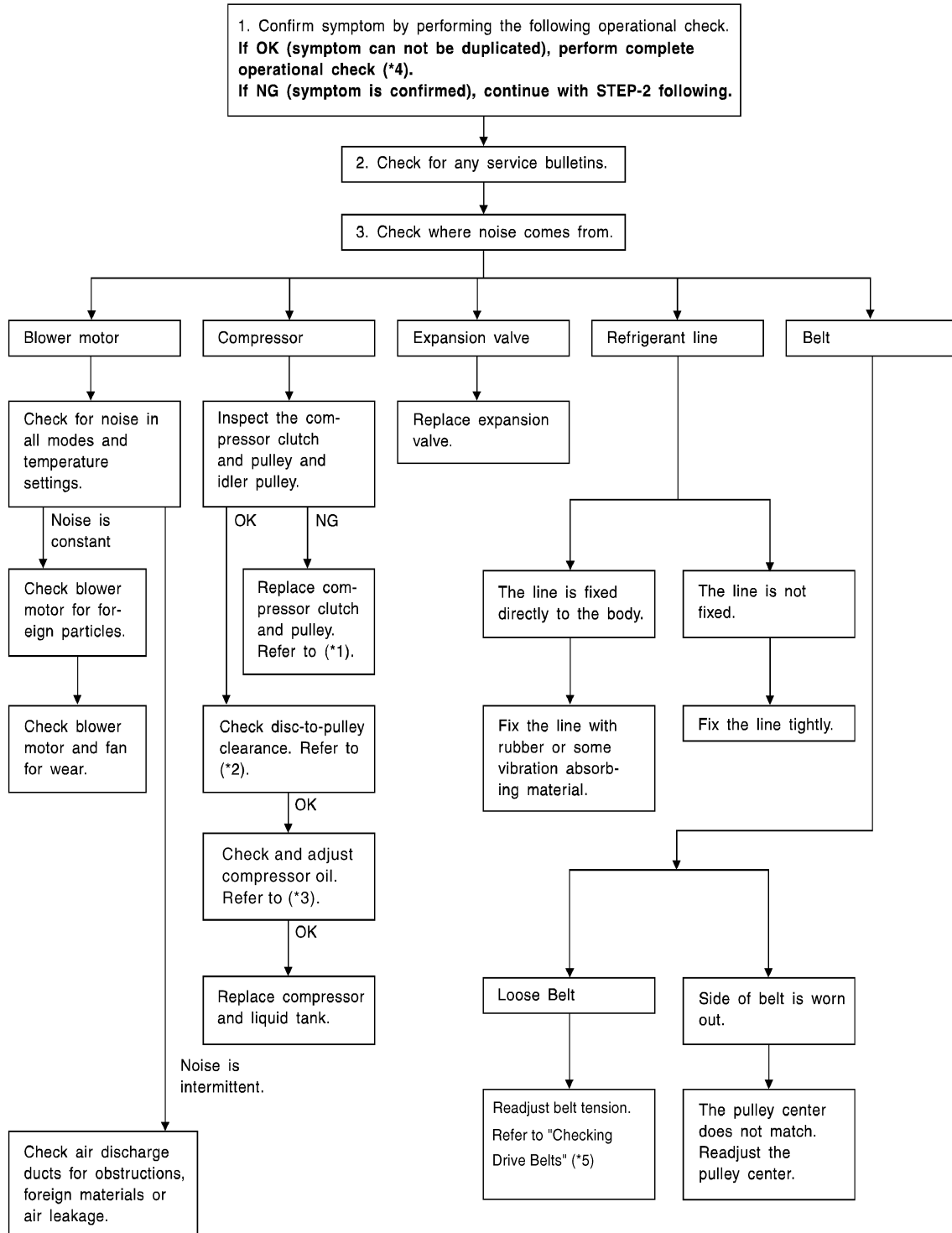

A  
B  
C  
D  
E  
F  
G  
H  
HAC  
J  
K  
L  
M  
N  
O  
P

# NOISE

< SYMPTOM DIAGNOSIS >

[MANUAL A/C (TYPE 1)]

---

- \*1 [HA-34. "Removal and Installation for Compressor Clutch"](#)
- \*2 [HA-34. "Removal and Installation for Compressor Clutch"](#)
- \*3 [HA-20. "Maintenance of Oil Quantity in Compressor"](#)
- \*4 [HAC-101. "Operational Check"](#)
- \*5 [EM-12. "Checking Drive Belts"](#)

PRECAUTION

PRECAUTIONS

Supplemental Restraint System (SRS) "AIR BAG" and "SEAT BELT PRE-TENSIONER"

INFOID:000000001669189

The Supplemental Restraint System such as "AIR BAG" and "SEAT BELT PRE-TENSIONER", used along with a front seat belt, helps to reduce the risk or severity of injury to the driver and front passenger for certain types of collision. This system includes seat belt switch inputs and dual stage front air bag modules. The SRS system uses the seat belt switches to determine the front air bag deployment, and may only deploy one front air bag, depending on the severity of a collision and whether the front occupants are belted or unbelted. Information necessary to service the system safely is included in the SR and SB section of this Service Manual.

**WARNING:**

- To avoid rendering the SRS inoperative, which could increase the risk of personal injury or death in the event of a collision which would result in air bag inflation, all maintenance must be performed by an authorized NISSAN/INFINITI dealer.
- Improper maintenance, including incorrect removal and installation of the SRS, can lead to personal injury caused by unintentional activation of the system. For removal of Spiral Cable and Air Bag Module, see the SR section.
- Do not use electrical test equipment on any circuit related to the SRS unless instructed to in this Service Manual. SRS wiring harnesses can be identified by yellow and/or orange harnesses or harness connectors.

Working with HFC-134a (R-134a)

INFOID:000000001669190

**WARNING:**

- CFC-12 (R-12) refrigerant and HFC-134a (R-134a) refrigerant are not compatible. If the refrigerants are mixed compressor failure is likely to occur. Refer to HA-4, "[Contaminated Refrigerant](#)". To determine the purity of HFC-134a (R-134a) in the vehicle and recovery tank, use Refrigerant Recovery/Recycling Recharging equipment and Refrigerant Identifier.
- Use only specified oil for the HFC-134a (R-134a) A/C system and HFC-134a (R-134a) components. If oil other than that specified is used, compressor failure is likely to occur.
- The specified HFC-134a (R-134a) oil rapidly absorbs moisture from the atmosphere. The following handling precautions must be observed:
  - When removing refrigerant components from a vehicle, immediately cap (seal) the component to minimize the entry of moisture from the atmosphere.
  - When installing refrigerant components to a vehicle, do not remove the caps (unseal) until just before connecting the components. Connect all refrigerant loop components as quickly as possible to minimize the entry of moisture into system.
  - Only use the specified oil from a sealed container. Immediately reseal containers of oil. Without proper sealing, oil will become moisture saturated and should not be used.
  - Avoid breathing A/C refrigerant and oil vapor or mist. Exposure may irritate eyes, nose and throat. Remove HFC-134a (R-134a) from the A/C system using certified service equipment meeting requirements of SAE J2210 [HFC-134a (R-134a) recycling equipment], or J2209 [HFC-134a (R-134a) recycling equipment], If accidental system discharge occurs, ventilate work area before resuming service. Additional health and safety information may be obtained from refrigerant and oil manufacturers.
  - Do not allow A/C oil to come in contact with styrofoam parts. Damage may result.

CONTAMINATED REFRIGERANT

If a refrigerant other than pure HFC-134a (R-134a) is identified in a vehicle, your options are:

- Explain to the customer that environmental regulations prohibit the release of contaminated refrigerant into the atmosphere.
- Explain that recovery of the contaminated refrigerant could damage your service equipment and refrigerant supply.
- Suggest the customer return the vehicle to the location of previous service where the contamination may have occurred.
- If you choose to perform the repair, recover the refrigerant using only **dedicated equipment and containers. Do not recover contaminated refrigerant into your existing service equipment.** If your facility does

A  
B  
C  
D  
E  
F  
G  
H  
HAC  
J  
K  
L  
M  
N  
O  
P

# PRECAUTIONS

[MANUAL A/C (TYPE 1)]

## < PRECAUTION >

not have dedicated recovery equipment, you may contact a local refrigerant product retailer for available service. This refrigerant must be disposed of in accordance with all federal and local regulations. In addition, replacement of all refrigerant system components on the vehicle is recommended.

- If the vehicle is within the warranty period, the air conditioner warranty is void. Please contact NISSAN Customer Affairs for further assistance.

## Precaution for Service Equipment

INFOID:000000001669191

### MANIFOLD GAUGE SET

Be certain that the gauge face indicates R-134a or 134a. Make sure the gauge set has 1/2"-16 ACME threaded connections for service hoses. Confirm the set has been used only with refrigerant HFC-134a (R-134a) along with specified oil.

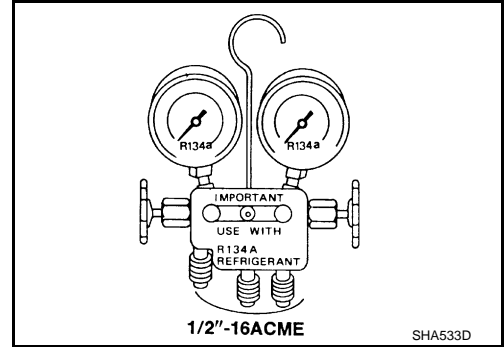

### SERVICE HOSES

Be certain that the service hoses display the markings described (colored hose with black stripe). All hoses must include positive shut-off devices (either manual or automatic) near the end of the hoses opposite the manifold gauge.

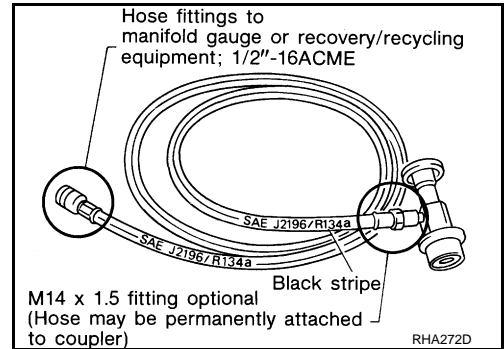

### SERVICE COUPLERS

Never attempt to connect HFC-134a (R-134a) service couplers to a CFC-12 (R-12) A/C system. The HFC-134a (R-134a) couplers will not properly connect to the CFC-12 (R-12) system. However, if an improper connection is attempted, discharging and contamination may occur.

Shut-off valve rotation	A/C service valve
Clockwise	Open
Counterclockwise	Close

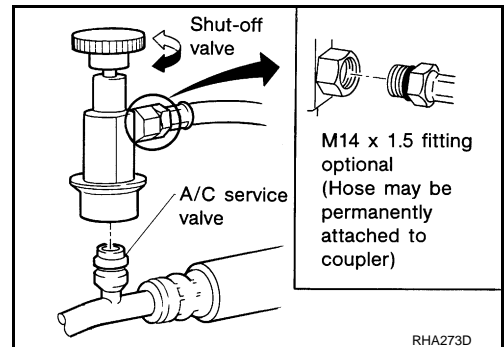

# MANUAL A/C IDENTIFICATION TABLE

< BASIC INSPECTION >

[MANUAL A/C (TYPE 2)]

## BASIC INSPECTION

### MANUAL A/C IDENTIFICATION TABLE

#### Application Table

INFOID:000000001678296

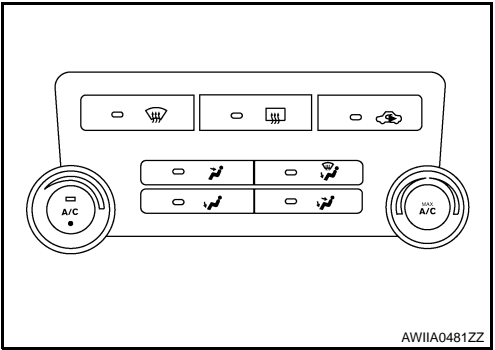
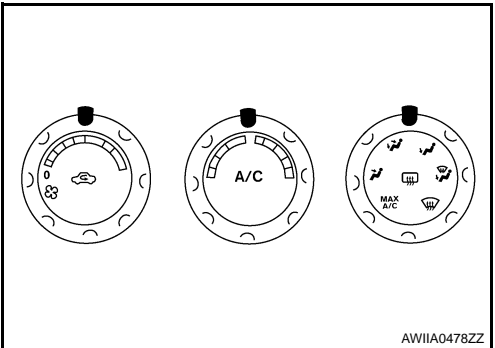
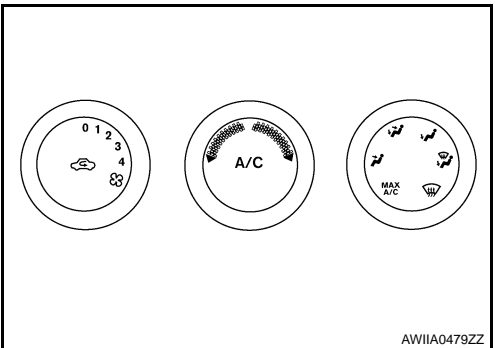
Manual A/C Type	Description	Visual Identification
Manual A/C (Type 1)	Two Control Dial System	
Manual A/C (Type 2)	Three Control Dial System [with variable blower control (VBC)]	
Manual A/C (Type 3)	Three Control Dial System [without variable blower control (VBC)]	

A  
B  
C  
D  
E  
F  
G  
H  
I  
J  
K  
L  
M  
N  
O  
P

HAC

# DIAGNOSIS AND REPAIR WORKFLOW

< BASIC INSPECTION >

[MANUAL A/C (TYPE 2)]

---

## DIAGNOSIS AND REPAIR WORKFLOW

How to Perform Trouble Diagnosis For Quick And Accurate Repair

INFOID:000000001678297

### WORK FLOW

#### 1. LISTEN TO CUSTOMER COMPLAINT

---

Listen to customer complaint. Get detailed information about the conditions and environment when the symptom occurs.

>> GO TO 2

#### 2. CHECK FOR SERVICE BULLETINS

---

Check for any service bulletins.

>> GO TO 3.

#### 3. VERIFY THE SYMPTOM WITH OPERATIONAL CHECK

---

Verify the symptom with operational check. Refer to [HAC-183. "Operational Check"](#).

>> GO TO 4

#### 4. GO TO APPROPRIATE TROUBLE DIAGNOSIS

---

Go to appropriate trouble diagnosis. Refer to [HAC-243. "Symptom Matrix Chart"](#).

>> GO TO 5.

#### 5. REPAIR OR REPLACE

---

Repair or replace the specific parts.

>> GO TO 6

#### 6. FINAL CHECK

---

Final check.

Is the inspection result normal?

YES >> CHECK OUT

NO >> GO TO 4

## INSPECTION AND ADJUSTMENT

## Operational Check

INFOID:000000001678298

The purpose of the operational check is to confirm that the system operates properly.

**Conditions** : Engine running and at normal operating temperature

## CHECKING BLOWER

1. Rotate the blower control dial clockwise once, blower should operate on low speed.
2. Rotate the blower control dial again, and continue checking blower speed until all speeds are checked.
3. Leave blower on maximum speed.

If NG, go to trouble diagnosis procedure for [HAC-216, "Front Blower Motor Diagnosis Procedure"](#).

If OK, continue with next check.

## CHECKING DISCHARGE AIR

1. Rotate MODE control dial to each position and the DEF  mode.
2. Confirm that discharge air comes out according to the air distribution table. Refer to [HAC-191, "Discharge Air Flow"](#)

Mode door position is checked in the next step.



If NG, go to trouble diagnosis procedure for [HAC-198, "Mode Door Motor Diagnosis Procedure"](#).

If OK, continue the check.

**NOTE:**

Confirm that the compressor clutch is engaged (sound or visual inspection) and intake door position is at fresh when the DEF or D/F is selected.





CHECKING RECIRCULATION ( ,  ONLY)

1. Press recirculation (  ) switch one time. Recirculation indicator should illuminate.
2. Press recirculation (  ) switch one more time. Recirculation indicator should go off.
3. Listen for intake door position change (blower sound should change slightly).

If NG, go to trouble diagnosis procedure for [HAC-208, "Intake Door Motor Diagnosis Procedure"](#).

If OK, continue the check.

**NOTE:**

Confirm that the compressor clutch is engaged (sound or visual inspection) and intake door position is at fresh when the DEF or D/F is selected. REC (  ) is not allowed in DEF (  ) D/F (  ) or FOOT (  ).

## CHECKING TEMPERATURE DECREASE

1. Rotate temperature control dial counterclockwise until maximum cold.
2. Check for cold air at appropriate discharge air outlets.

If NG, listen for sound of air mix door motor operation. If OK, go to trouble diagnosis procedure for [HAC-244, "Component Function Check"](#). If air mix door motor appears to be malfunctioning, go to [HAC-203, "Air Mix Door Motor Diagnosis Procedure"](#).

If OK, continue the check.

## CHECKING TEMPERATURE INCREASE

1. Rotate temperature control dial clockwise until maximum hot.
2. Check for hot air at appropriate discharge air outlets.

If NG, listen for sound of air mix door motor operation. If OK, go to trouble diagnosis procedure for [HAC-252, "Component Function Check"](#). If air mix door motor appears to be malfunctioning, go to [HAC-203, "Air Mix Door Motor Diagnosis Procedure"](#).

If OK, continue with next check.

## CHECK A/C SWITCH

1. Press A/C switch.
  - Confirm that the compressor clutch engages (sound or visual inspection).

**NOTE:**

If current mode setting is DEF or D/F, compressor clutch will already be engaged and cannot be turned off.

## INSPECTION AND ADJUSTMENT

< BASIC INSPECTION >

[MANUAL A/C (TYPE 2)]

If NG, go to trouble diagnosis procedure for [HAC-221, "Magnet Clutch Diagnosis Procedure"](#).  
If all operational checks are OK (symptom cannot be duplicated), go to [HAC-182, "How to Perform Trouble Diagnosis For Quick And Accurate Repair"](#) and perform tests as outlined. If symptom appears, refer to [HAC-243, "Symptom Matrix Chart"](#) and perform applicable trouble diagnosis procedures.



# MANUAL A/C IDENTIFICATION TABLE

< FUNCTION DIAGNOSIS >

[MANUAL A/C (TYPE 2)]

## FUNCTION DIAGNOSIS

### MANUAL A/C IDENTIFICATION TABLE

#### Application Table

INFOID:000000001678299

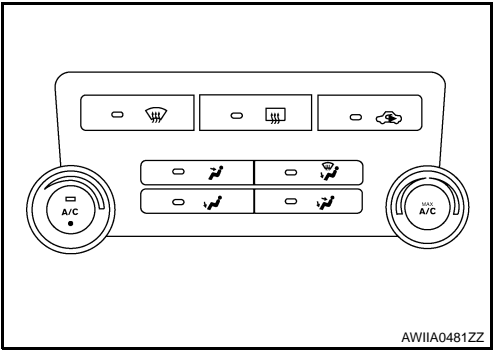
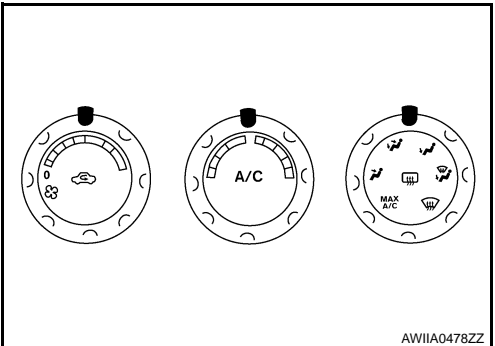
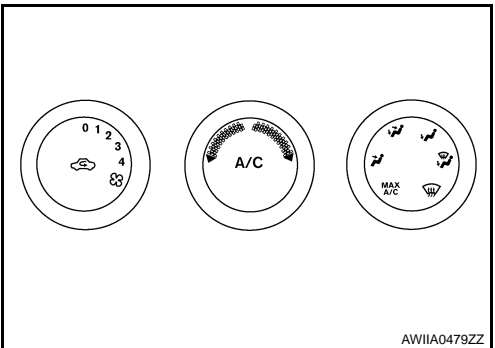
Manual A/C Type	Description	Visual Identification
Manual A/C (Type 1)	Two Control Dial System	
Manual A/C (Type 2)	Three Control Dial System [with variable blower control (VBC)]	
Manual A/C (Type 3)	Three Control Dial System [without variable blower control (VBC)]	

A  
B  
C  
D  
E  
F  
G  
H  
I  
J  
K  
L  
M  
N  
O  
P

**HAC**

## FUNCTION INFORMATION

### Component Part Location

INFOID:000000001678300

### ENGINE COMPARTMENT

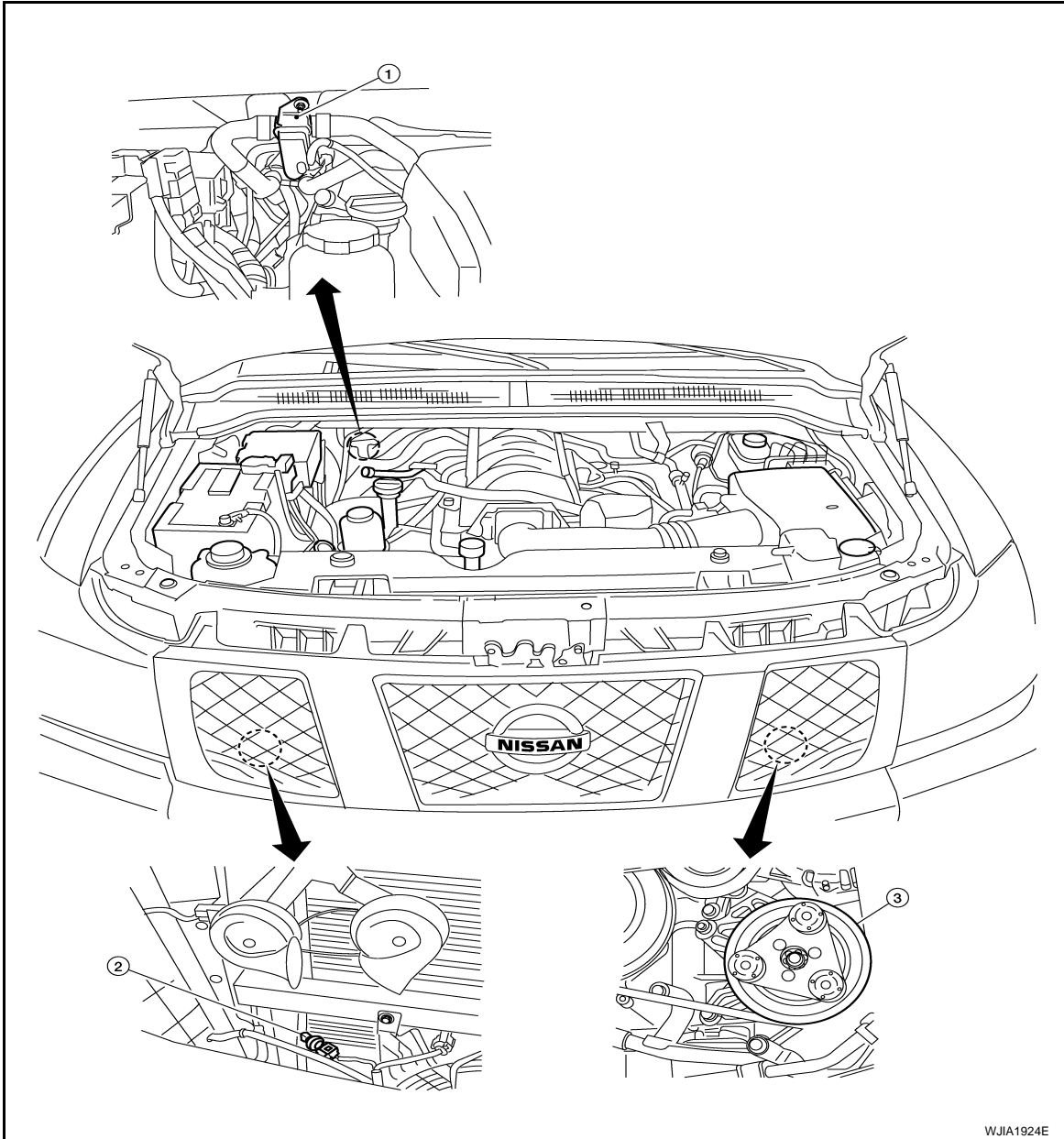

WJIA1924E

1. Water valve F68
2. Refrigerant pressure sensor E48 (view with grille removed)
3. A/C Compressor F3

PASSENGER COMPARTMENT

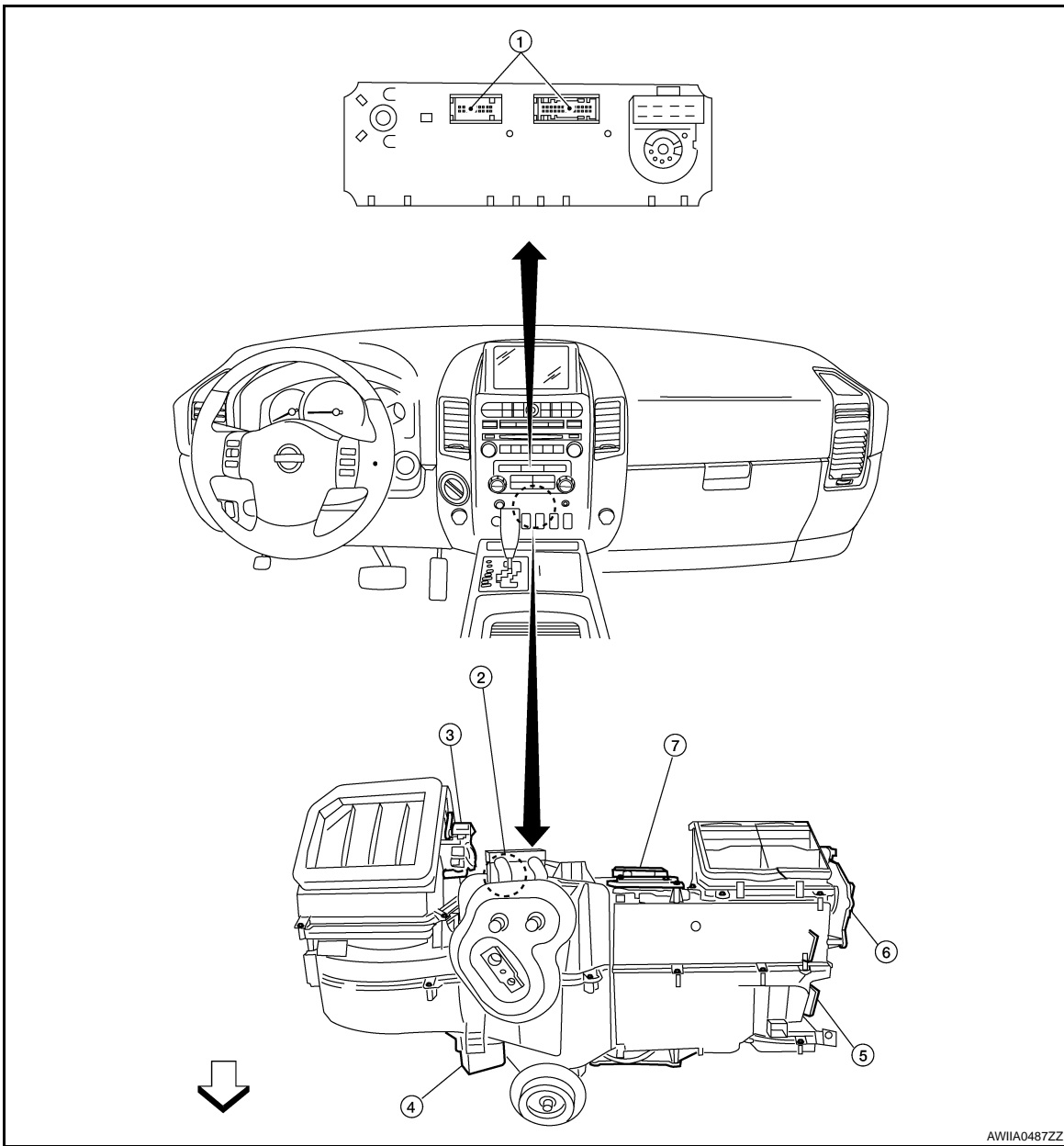

AWIA0487ZZ

- |                                    |                         |                              |
|------------------------------------|-------------------------|------------------------------|
| 1. Front air control M49, M50      | 2. Intake sensor M146   | 3. Intake door motor M58     |
| 4. Variable blower control M122    | 5. Mode door motor M142 | 6. Defroster door motor M144 |
| 7. Air mix door motor (front) M147 |                         |                              |

A  
B  
C  
D  
E  
F  
G  
H  
HAC  
J  
K  
L  
M  
N  
O  
P

# FUNCTION INFORMATION

< FUNCTION DIAGNOSIS >

[MANUAL A/C (TYPE 2)]

## Symptom Table

INFOID:000000001678301

Symptom	Reference Page	
A/C system does not come on.	Go to Trouble Diagnosis Procedure for A/C System.	<a href="#">HAC-231</a>
Air outlet does not change.	Go to Trouble Diagnosis Procedure for Mode Door Motor.	<a href="#">HAC-197</a>
Mode door motor is malfunctioning.		
Discharge air temperature does not change.	Go to Trouble Diagnosis Procedure for Air Mix Door Motor.	<a href="#">HAC-202</a>
Air mix door motor is malfunctioning.		
Intake door does not change.	Go to Trouble Diagnosis Procedure for Intake Door Motor.	<a href="#">HAC-207</a>
Intake door motor is malfunctioning.		
Defroster door motor is malfunctioning.	Go to Trouble Diagnosis Procedure for Defroster Door Motor.	<a href="#">HAC-210</a>
Front blower motor operation is malfunctioning.	Go to Trouble Diagnosis Procedure for Front Blower Motor.	<a href="#">HAC-215</a>
Magnet clutch does not engage.	Go to Trouble Diagnosis Procedure for Magnet Clutch.	<a href="#">HAC-221</a>
Insufficient cooling	Go to Trouble Diagnosis Procedure for Insufficient Cooling.	<a href="#">HAC-244</a>
Insufficient heating	Go to Trouble Diagnosis Procedure for Insufficient Heating.	<a href="#">HAC-252</a>
Noise	Go to Trouble Diagnosis Procedure for Noise.	<a href="#">HAC-254</a>

## REFRIGERATION SYSTEM

Refrigerant Cycle

INFOID:000000001678302

Refer to [HAC-189. "Refrigerant Cycle"](#).

Refrigerant System Protection

INFOID:000000001678303

Refer to [HA-15. "Refrigerant System Protection"](#).

A

B

C

D

E

F

G

H

**HAC**

J

K

L

M

N

O

P

# MANUAL AIR CONDITIONER SYSTEM

< FUNCTION DIAGNOSIS >

[MANUAL A/C (TYPE 2)]

## MANUAL AIR CONDITIONER SYSTEM

### Control System Diagram

INFOID:000000001678304

#### CONTROL SYSTEM

The control system consists of input sensors, switches, the front air control (microcomputer) and outputs. The relationship of these components is shown in the figure below:

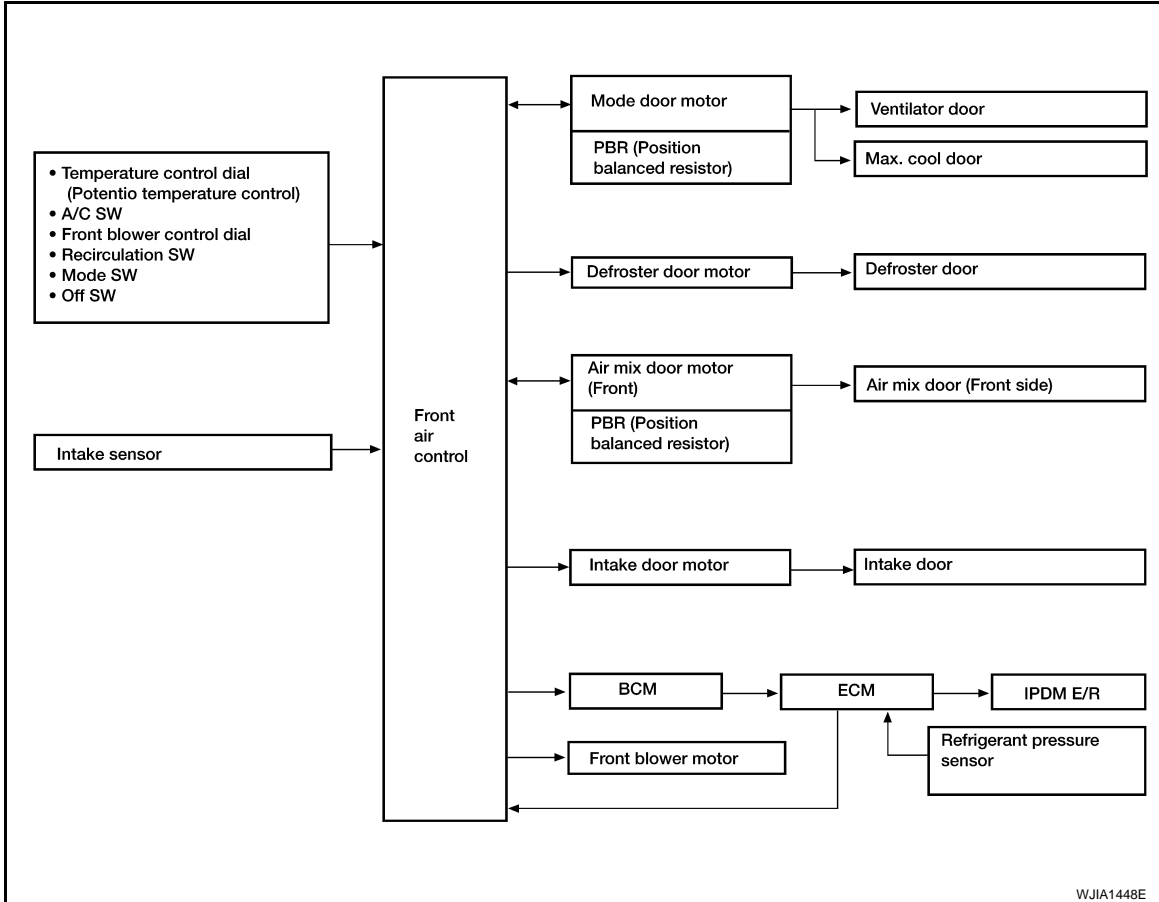

WJIA1448E

### Control System Description

INFOID:000000001678305

#### CONTROL OPERATION

##### Front air control

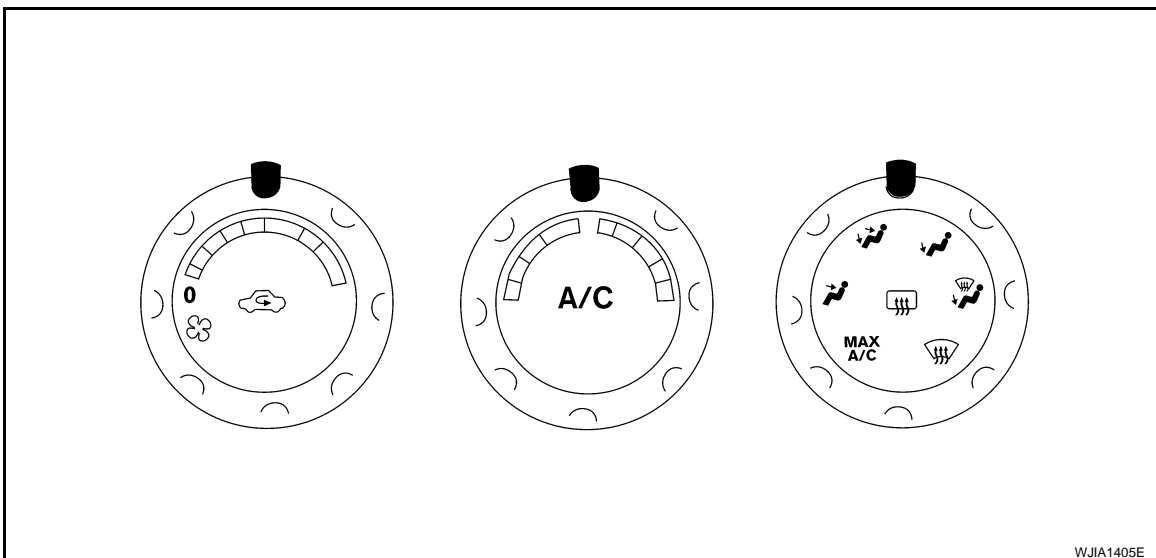

WJIA1405E

# MANUAL AIR CONDITIONER SYSTEM

< FUNCTION DIAGNOSIS >

[MANUAL A/C (TYPE 2)]

## TEMPERATURE CONTROL DIAL

Increases or decreases the set temperature.

## RECIRCULATION ( ) SWITCH

- When REC switch is ON, REC switch indicator turns ON, and air inlet is set to REC.
- When REC switch is turned OFF, or when compressor is turned from ON to OFF, REC switch is automatically turned OFF. REC mode can be re-entered by pressing REC switch again.
- REC switch is not operated when DEF switch is turned ON, at the D/F position, or in floor position.

## DEFROSTER ( ) SWITCH

Positions the air outlet doors to the defrost position. Also positions the intake doors to the outside air position, and turns A/C compressor ON.

## REAR WINDOW DEFOGGER SWITCH (IF EQUIPPED)

When switch is ON, rear window and door mirrors are defogged.

## BLOWER CONTROL DIAL/OFF SWITCH

- The blower speed is manually controlled with this dial.
- The compressor and blower are OFF, the intake doors are set to the outside air position, and the air outlet doors are set to the foot position.

## A/C SWITCH

The compressor is ON or OFF.

(Pressing the A/C switch when the AUTO switch is ON will turn off the A/C switch and compressor.)

## MODE CONTROL DIAL

Controls the air discharge outlets.

## MAGNET CLUTCH CONTROL

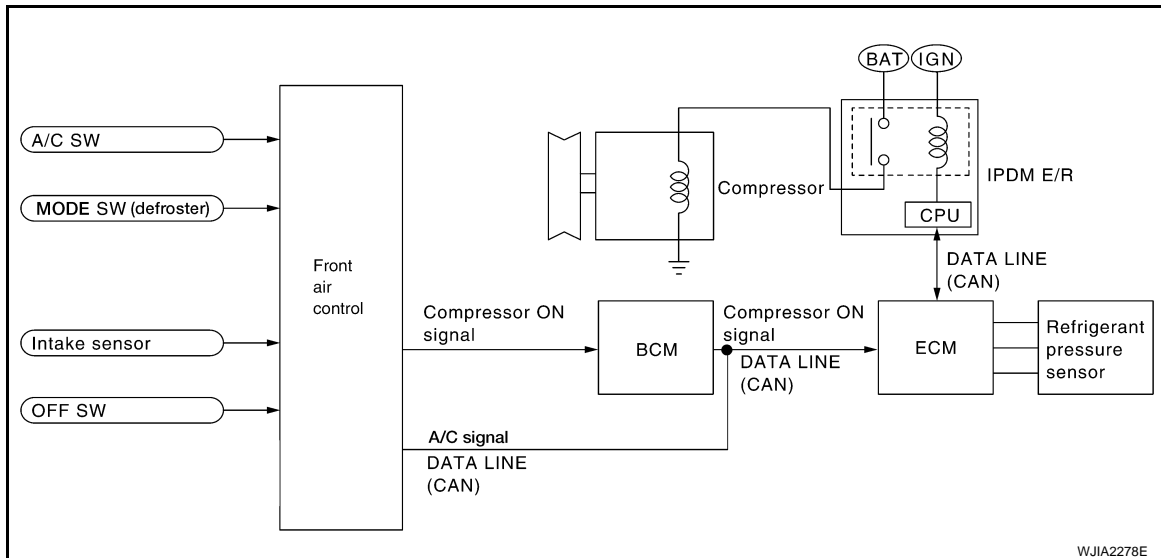

When A/C switch or DEF switch is pressed, front air control inputs compressor ON signal to BCM.

BCM sends compressor ON signal to ECM and front air control, via CAN communication line.

ECM judges whether compressor can be turned ON, based on each sensor status (refrigerant pressure sensor signal, throttle angle sensor, etc.). If it judges compressor can be turned ON, it sends compressor ON signal to IPDM E/R, via CAN communication line.

Upon receipt of compressor ON signal from ECM, IPDM E/R turns air conditioner relay ON to operate compressor.

## Discharge Air Flow

INFOID:000000001678306

# MANUAL AIR CONDITIONER SYSTEM

< FUNCTION DIAGNOSIS >

[MANUAL A/C (TYPE 2)]

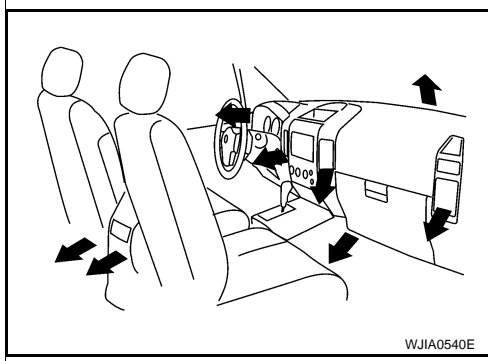

Mode door position	Air outlet/distribution		
	Vent	Foot	Defroster
	95%	5%	—
	60%	40%	—
	—	70%	30%
	—	60%	40%
	—	10%	90%

## Switches And Their Control Function

INFOID:000000001678307

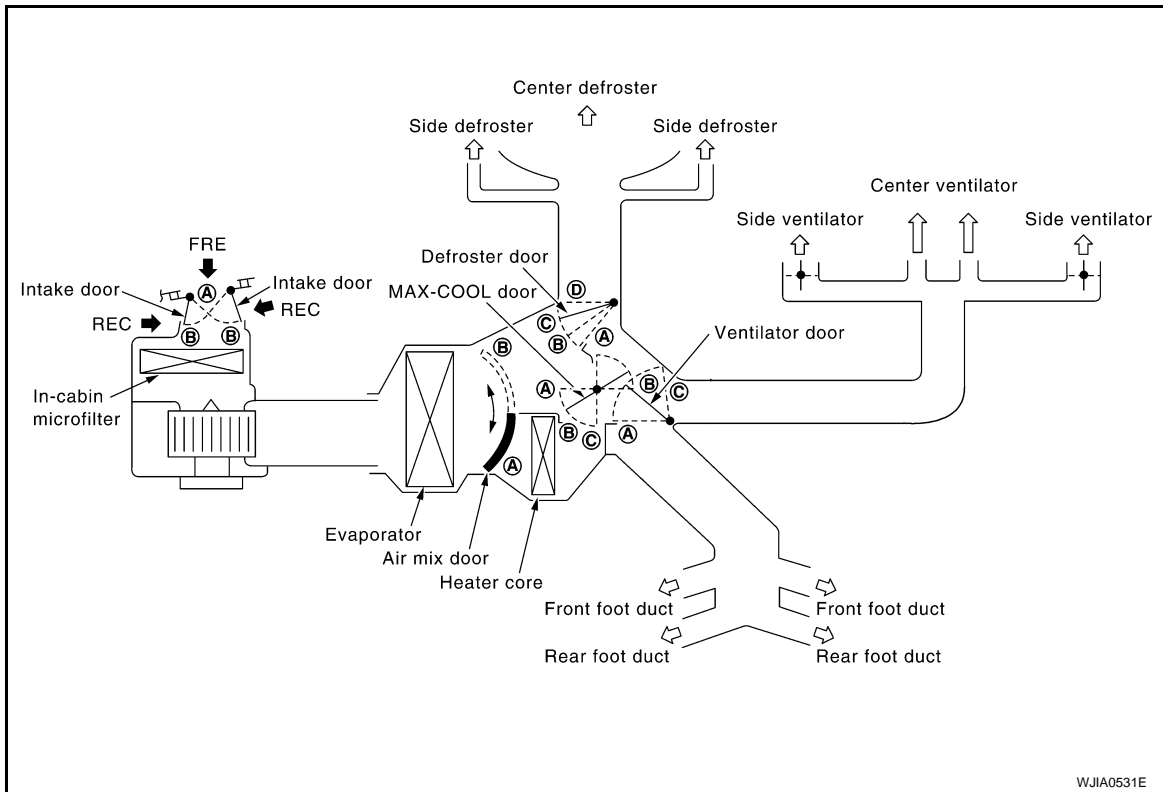



# MANUAL AIR CONDITIONER SYSTEM

< FUNCTION DIAGNOSIS >

[MANUAL A/C (TYPE 2)]

Door	Position or switch	MODE SW				DEF SW		REC SW		Temperature switch			OFF SW
		VENT	B/L	FOOT	D/F	ON	OFF	ON	OFF				
										COLD	~	HOT	
Ventilator door		(A)	(B)	(C)	(C)	(C)	—	—	—	—	—	(C)	
MAX-COOL door		(A)	(B)	(B)	(B)	(C)	—	—	—	—	—	(B)	
Defroster door		(D)	(D)	(D <sub>or</sub> C)	(B)	(A)	—	—	—	—	—	(C)	
Intake door		—				(B)	—	(A)	(B)	—			(B)
Air mix door		—				—	—	—		(A)		(B)	—

WJIA1406E

A  
B  
C  
D  
E  
F  
G  
H  
J  
K  
L  
M  
N  
O  
P

HAC

## CAN COMMUNICATION SYSTEM

### System Description

INFOID:000000001678308

Refer to [LAN-4. "System Description"](#).

## DIAGNOSIS SYSTEM (BCM)

### CONSULT-III Function (BCM)

INFOID:000000001678309

CONSULT-II can display each diagnostic item using the diagnostic test modes shown following.

BCM diagnostic test item	Diagnostic mode	Description
Inspection by part	WORK SUPPORT	Supports inspections and adjustments. Commands are transmitted to the BCM for setting the status suitable for required operation, input/output signals are received from the BCM and received data is displayed.
	DATA MONITOR	Displays BCM input/output data in real time.
	ACTIVE TEST	Operation of electrical loads can be checked by sending drive signal to them.
	SELF-DIAG RESULTS	Displays BCM self-diagnosis results.
	CAN DIAG SUPPORT MNTR	The result of transmit/receive diagnosis of CAN communication can be read.
	ECU PART NUMBER	BCM part number can be read.
	CONFIGURATION	Performs BCM configuration read/write functions.

### DATA MONITOR

#### Display Item List

Monitor item name "operation or unit"	Contents
IGN ON SW "ON/OFF"	Displays "IGN Position (ON)/OFF, ACC Position (OFF)" status as judged from ignition switch signal.
COMP ON SIG "ON/OFF"	Displays "COMP (ON)/COMP (OFF)" status as judged from air conditioner switch signal.
FAN ON SIG "ON/OFF"	Displays "FAN (ON)/FAN (OFF)" status as judged from blower motor switch signal.

# MANUAL A/C IDENTIFICATION TABLE

< COMPONENT DIAGNOSIS >

[MANUAL A/C (TYPE 2)]

## COMPONENT DIAGNOSIS

### MANUAL A/C IDENTIFICATION TABLE

#### Application Table

INFOID:000000001678310

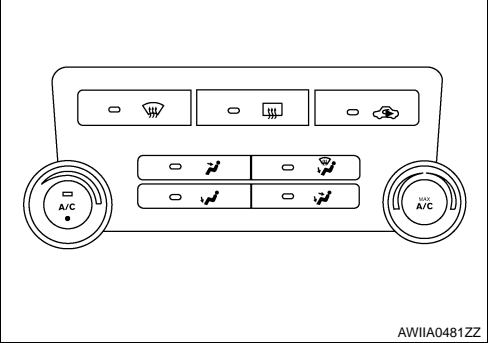
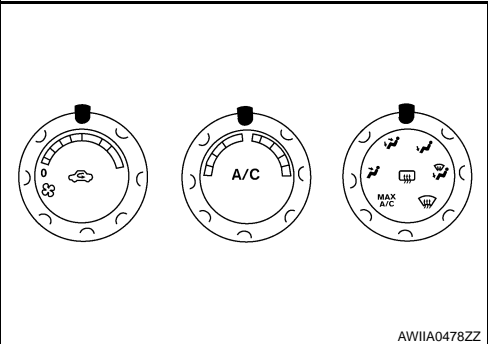
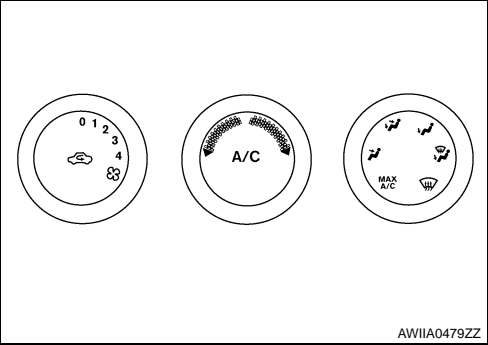
Manual A/C Type	Description	Visual Identification
Manual A/C (Type 1)	Two Control Dial System	 <p style="text-align: right;">AWIIA0481ZZ</p>
Manual A/C (Type 2)	Three Control Dial System [with variable blower control (VBC)]	 <p style="text-align: right;">AWIIA0478ZZ</p>
Manual A/C (Type 3)	Three Control Dial System [(without variable blower control (VBC))]	 <p style="text-align: right;">AWIIA0479ZZ</p>

## MODE DOOR MOTOR

### System Description

INFOID:000000001678311

### SYSTEM DESCRIPTION

#### Component Parts

Mode door control system components are:

- Front air control
- Mode door motor
- PBR (built into mode door motor)
- Intake sensor

#### System Operation

The mode door position (vent, B/L, foot, D/F, and defrost) is set by the front air control by means of the mode door motor. When a mode door position is selected on the front air control, voltage is applied to one circuit of the mode door motor while ground is applied to the other circuit, causing the mode door motor to rotate. The direction of rotation is determined by which circuit has voltage applied to it, and which one has ground applied to it. The front air control monitors the mode door position by measuring the voltage signal on the PBR circuit.

### COMPONENT DESCRIPTION

#### Mode Door Motor

The mode door motor is attached to the heater & cooling unit assembly. It rotates so that air is discharged from the outlet as indicated by the front air control. Motor rotation is conveyed to a link which activates the mode door.

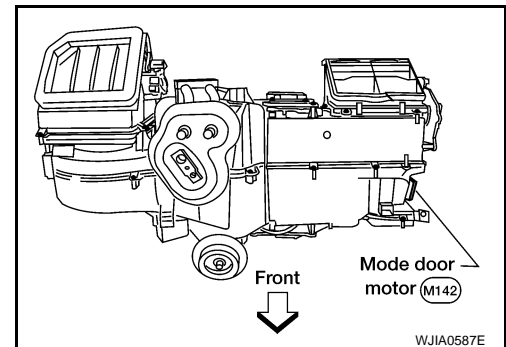

### Mode Door Motor Component Function Check

INFOID:000000001678312

#### INSPECTION FLOW

#### 1. CONFIRM SYMPTOM BY PERFORMING OPERATIONAL CHECK - DISCHARGE AIR

1. Rotate the mode control dial and check each position and press the (DEF) mode.
2. Confirm that discharge air comes out according to the air distribution table. Refer to [HAC-191, "Discharge Air Flow"](#).

#### NOTE:

Confirm that the compressor clutch is engaged (visual inspection) and intake door position is at FRESH when DEF () or D/F () is selected.

#### Can a symptom be duplicated?

- YES >> GO TO 3.  
NO >> GO TO 2.

#### 2. PERFORM COMPLETE OPERATIONAL CHECK

Perform a complete operational check and check for any symptoms. Refer to [HAC-183, "Operational Check"](#).

#### Can a symptom be duplicated?

- YES >> Refer to [HAC-182, "How to Perform Trouble Diagnosis For Quick And Accurate Repair"](#).  
NO >> System OK.

#### 3. CHECK FOR SERVICE BULLETINS

Check for any service bulletins.

# MODE DOOR MOTOR

< COMPONENT DIAGNOSIS >

[MANUAL A/C (TYPE 2)]

>> GO TO 4.

## 4. CHECK MODE DOOR OPERATION

Check and verify mode door mechanism for smooth operation in each mode.

Is the inspection result normal?

YES >> GO TO 5.

NO >> Repair as necessary.

## 5. CHECK THE MODE DOOR MOTOR PBR CIRCUIT

Perform diagnostic procedure for the mode door motor. Refer to [HAC-197. "Mode Door Motor Component Function Check"](#).

Is the inspection result normal?

YES >> GO TO 6.

NO >> Repair PBR circuit or replace motor. Refer to [HAC-198. "Mode Door Motor Diagnosis Procedure"](#).

## 6. RECHECK FOR SYMPTOMS

Perform a complete operational check and check for any symptoms. Refer to [HAC-183. "Operational Check"](#).

Does another symptom exist?

YES >> Repair as necessary.

NO >> Replace front air control Refer to [VTL-8. "Removal and Installation"](#).

## Mode Door Motor Diagnosis Procedure

INFOID:000000001678313

SYMPTOM:

- Air outlet does not change.
- Mode door motor does not operate normally.

## 1. CHECK FRONT AIR CONTROL FOR POWER AND GROUND

1. Turn ignition switch ON.
2. Press the B/L (↺) mode switch.
3. Check voltage between front air control harness connector M49 terminal 5 and terminal 6 while pressing the mode switch to the floor (↵) mode.

Connector	Terminals		Condition	Voltage (Approx.)
	(+)	(-)		
Front air control: M49	6	5	Press mode switch	Battery voltage

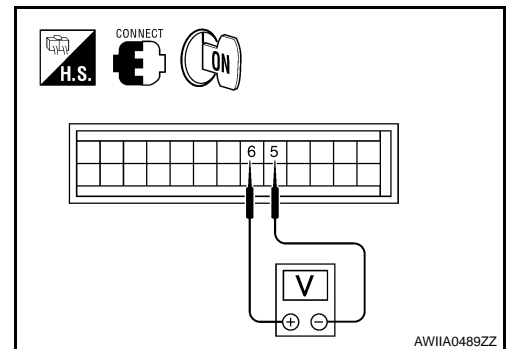

Is the inspection result normal?

YES >> GO TO 4.

NO >> GO TO 3.

## 2. CHECK MODE DOOR MOTOR CIRCUITS FOR SHORT TO GROUND

1. Turn ignition switch OFF.
2. Disconnect the front air control harness connector.
3. Check continuity between front air control harness connector M49 terminal 5, 6 and ground.

**5 - Ground : Continuity should not exist.**

**6 - Ground : Continuity should not exist.**

Is the inspection result normal?

YES >> Replace front air control. Refer to [VTL-8. "Removal and Installation"](#).

NO >> Repair or replace harness as necessary.

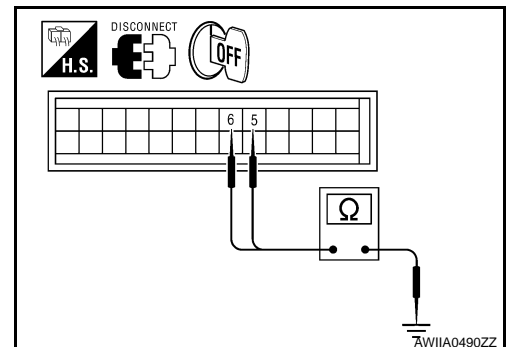

# MODE DOOR MOTOR

< COMPONENT DIAGNOSIS >

[MANUAL A/C (TYPE 2)]

## 3. CHECK FRONT AIR CONTROL FOR GROUND AND POWER

1. Press the mode switch to the D/F (D/F) mode.
2. Check voltage between front air control harness connector M49 terminal 5 and terminal 6 while pressing the mode switch to the vent (V) mode.

Connector	Terminals		Condition	Voltage (Approx.)
	(+)	(-)		
Front air control: M49	5	6	Press mode switch	Battery voltage

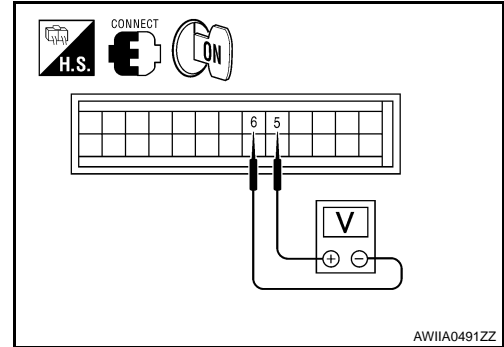

Is the inspection result normal?

YES >> GO TO 5.

NO >> Replace front air control. Refer to [VTL-8. "Removal and Installation"](#).

## 4. CHECK MODE DOOR MOTOR AND CIRCUITS FOR OPEN

1. Turn ignition switch OFF.
2. Disconnect the front air control harness connector.
3. Check continuity between front air control harness connector M49 terminal 5 and terminal 6.

**Continuity should exist.**

Is the inspection result normal?

YES >> GO TO 7.

NO >> GO TO 6.

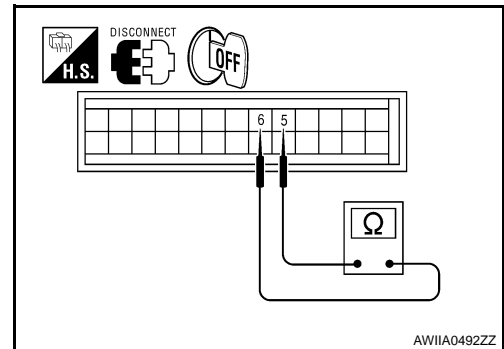

## 5. CHECK MODE DOOR MOTOR CIRCUITS FOR OPEN

1. Disconnect the mode door motor harness connector.
2. Check continuity between front air control harness connector M49 (A) terminal 5, 6 and the mode door motor harness connector M142 (B) terminal 5, 6.

**5 - 5 : Continuity should exist.**

**6 - 6 : Continuity should exist.**

Is the inspection result normal?

YES >> Replace mode door motor. Refer to [VTL-19. "Removal and Installation"](#).

NO >> Repair or replace harness as necessary.

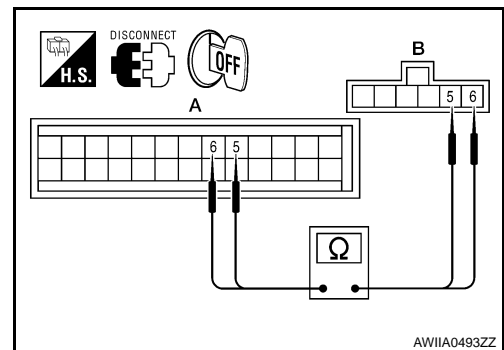

## 6. CHECK FRONT AIR CONTROL FOR PBR POWER AND GROUND

1. Reconnect front air control harness connector.
2. Turn ignition switch ON.
3. Check voltage between front air control harness connector M49 terminal 2 and 15.

Connector	Terminals		Voltage (Approx.)
	(+)	(-)	
Front air control: M49, M50	2	15	5V

Is the inspection result normal?

YES >> GO TO 9.

NO >> GO TO 8.

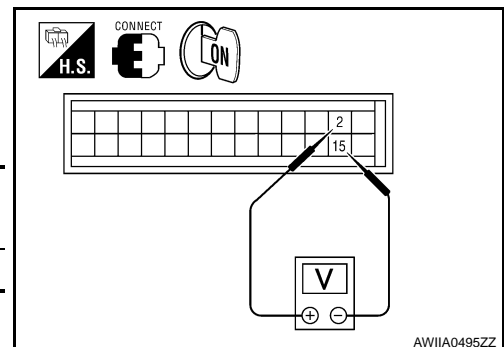

## 7. CHECK PBR REFERENCE VOLTAGE CIRCUIT FOR SHORT TO GROUND

A  
B  
C  
D  
E  
F  
G  
H  
HAC  
J  
K  
L  
M  
N  
O  
P

# MODE DOOR MOTOR

[MANUAL A/C (TYPE 2)]

## < COMPONENT DIAGNOSIS >

1. Turn ignition switch OFF.
2. Disconnect the front air control harness connector.
3. Check continuity between front air control harness connector M49 terminal 2 and ground.

**Continuity should not exist.**

Is the inspection result normal?

- YES >> Replace front air control Refer to [VTL-8, "Removal and Installation"](#).
- NO >> Repair or replace harness as necessary.

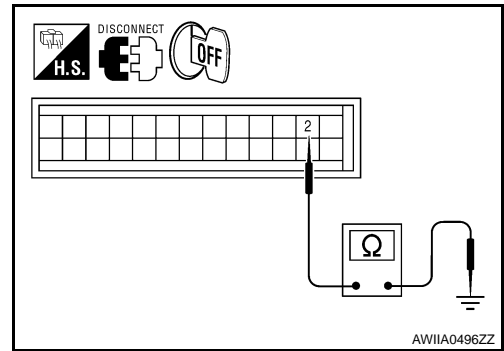

## 8.CHECK PBR REFERENCE VOLTAGE AND GROUND CIRCUITS

1. Turn ignition switch OFF.
2. Disconnect the front air control harness connector.
3. Check continuity between front air control harness connector M49 terminal 2 and terminal 15.

**Continuity should exist.**

Is the inspection result normal?

- YES >> GO TO 11.
- NO >> GO TO 10

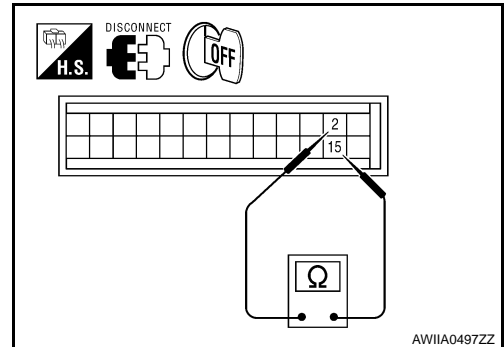

## 9.CHECK PBR REFERENCE VOLTAGE CIRCUIT FOR OPEN

1. Disconnect the mode door motor harness connector.
2. Check continuity between mode door motor harness connector M142 (B) terminal 3, 1 and front air control harness connector M49 (C) terminal 3, M50 (A) terminal 28.

**2 - 3 : Continuity should exist.**

**15 - 1 : Continuity should exist.**

Is the inspection result normal?

- YES >> Replace mode door motor. Refer to [VTL-19, "Removal and Installation"](#).
- NO >> Repair or replace harness as necessary.

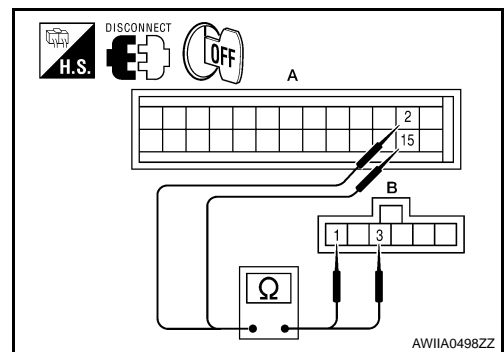

## 10.CHECK PBR FEEDBACK VOLTAGE

1. Reconnect the front air control harness connector.
2. Turn ignition switch ON.
3. Check voltage between front air control harness connector M49 terminal 16 and ground while cycling mode switch through all modes.

**Voltage : Approx. 1V - 4.5V**

Is the inspection result normal?

- YES >> GO TO 13.
- NO >> GO TO 12.

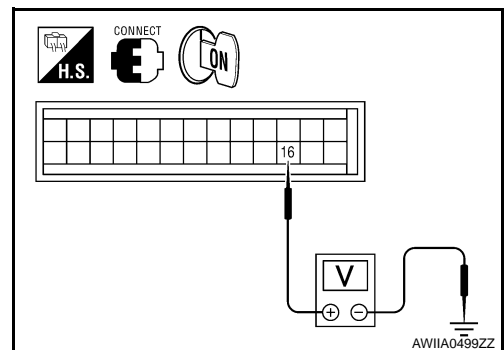

## 11.CHECK PBR FEEDBACK SIGNAL CIRCUIT FOR SHORT TO GROUND



# MODE DOOR MOTOR

[MANUAL A/C (TYPE 2)]

## < COMPONENT DIAGNOSIS >

1. Turn ignition switch OFF.
2. Disconnect front air control harness connector.
3. Check continuity between front air control harness connector M49 terminal 16 and ground.

**Continuity should not exist.**

Is the inspection result normal?

- YES >> Replace front air control Refer to [VTL-8, "Removal and Installation"](#).
- NO >> Repair or replace harness as necessary.

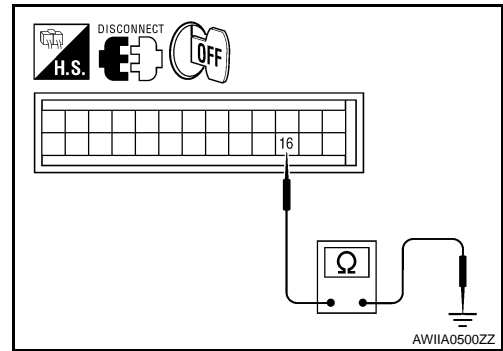

## 12.CHECK PBR FEEDBACK CIRCUIT FOR OPEN

1. Turn ignition switch OFF.
2. Disconnect the mode door motor harness connector and front air control harness connector.
3. Check continuity between mode door motor harness connector M142 terminal 2 and front air control harness connector M49 terminal 16.

**Continuity should exist.**

Is the inspection result normal?

- YES >> Replace mode door motor. Refer to [VTL-19, "Removal and Installation"](#).
- NO >> Repair or replace harness as necessary.

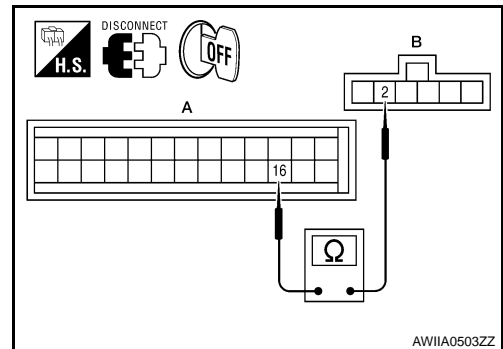

A  
B  
C  
D  
E  
F  
G  
H  
J  
K  
L  
M  
N  
O  
P

HAC

## AIR MIX DOOR MOTOR

### System Description

INFOID:000000001678314

#### SYSTEM DESCRIPTION

**SYMPTOM:**

- Discharge air temperature does not change.
- Air mix door motor does not operate.

#### SYSTEM DESCRIPTION

##### Component Parts

Air mix door control system components are:

- Front air control
- Air mix door motor
- PBR (built-into air mix door motors)
- Intake sensor

##### System Operation

The front air control receives data from the temperature selected by the driver side, passenger side, and rear. The front air control then applies a voltage to one circuit of the appropriate air mix door motor, while ground is applied to the other circuit, causing the appropriate air mix door motor to rotate. The direction of rotation is determined by which circuit has voltage applied to it, and which one has ground applied to it. The front air control monitors the air mix door positions by measuring the voltage signal on the PBR circuits of each door.

##### Air Mix Door Control Specification

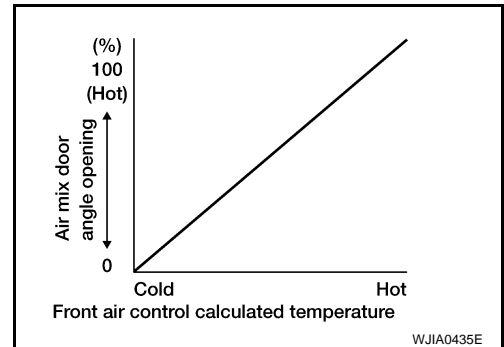

#### COMPONENT DESCRIPTION

##### Air Mix Door Motors

The air mix door motor is attached to the front heater & cooling unit assembly. The motor rotates so that the air mix door is opened or closed to a position set by the front air control. Motor rotation is then conveyed through a shaft and the air mix door position is then fed back to the front air control by the PBR built into the air mix door motor.

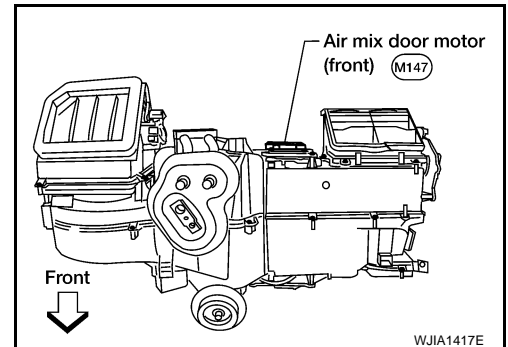

#### Air Mix Door Motor Component Function Check

INFOID:000000001678315

#### INSPECTION FLOW

### 1. CONFIRM SYMPTOM BY PERFORMING OPERATIONAL CHECK - TEMPERATURE INCREASE

1. Turn the temperature control dial clockwise to maximum hot.
2. Check for hot air at discharge air outlets.

# AIR MIX DOOR MOTOR

< COMPONENT DIAGNOSIS >

[MANUAL A/C (TYPE 2)]

>> GO TO 2.

## 2. CONFIRM SYMPTOM BY PERFORMING OPERATIONAL CHECK - TEMPERATURE DECREASE

1. Turn the temperature control dial counterclockwise to maximum cold.
2. Check for cold air at discharge air outlets.

Can a symptom be duplicated?

- YES >> GO TO 4.  
NO >> GO TO 3.

## 3. PERFORM COMPLETE OPERATIONAL CHECK

Perform a complete operational check and check for any symptoms. Refer to [HAC-183, "Operational Check"](#).

Can a symptom be duplicated?

- YES >> Refer to [HAC-182, "How to Perform Trouble Diagnosis For Quick And Accurate Repair"](#).  
NO >> System OK.

## 4. CHECK FOR SERVICE BULLETINS

Check for any service bulletins.

>> GO TO 5.

## 5. CHECK AIR MIX DOOR OPERATION

Check and verify air mix door mechanism for smooth operation from maximum cold °to maximum hot in each mode.

Is the inspection result normal?

- YES >> GO TO 6.  
NO >> Repair as necessary.

## 6. CHECK THE AIR MIX DOOR MOTOR PBR CIRCUIT

Perform diagnostic procedure for the air mix door motor. Refer to [HAC-202, "Air Mix Door Motor Component Function Check"](#).

Is the inspection result normal?

- YES >> GO TO 7.  
NO >> Repair PBR circuit or replace air mix door motor. Refer to [VTL-20, "Removal and Installation"](#).

## 7. RECHECK FOR ANY SYMPTOMS

Perform a complete operational check for any symptoms. Refer to [HAC-183, "Operational Check"](#).

Does another symptom exist?

- YES >> Refer to [HAC-182, "How to Perform Trouble Diagnosis For Quick And Accurate Repair"](#).  
NO >> Replace front air control Refer to [VTL-8, "Removal and Installation"](#).

## Air Mix Door Motor Diagnosis Procedure

INFOID:000000001678316

SYMPTOM:

- Discharge air temperature does not change.
- Air mix door motor does not operate.

## DIAGNOSTIC PROCEDURE FOR AIR MIX DOOR MOTOR

### 1. CHECK FRONT AIR CONTROL FOR POWER AND GROUND

# AIR MIX DOOR MOTOR

[MANUAL A/C (TYPE 2)]

## < COMPONENT DIAGNOSIS >

1. Turn ignition switch ON.
2. Rotate temperature control dial to maximum hot.
3. Check voltage between front air control harness connector M49 terminal 3 and terminal 4 while rotating temperature control dial to maximum cold.

Connector	Terminals		Condition	Voltage (Approx.)
	(+)	(-)		
Front air control: M49	3	4	Rotate temp control dial	Battery voltage

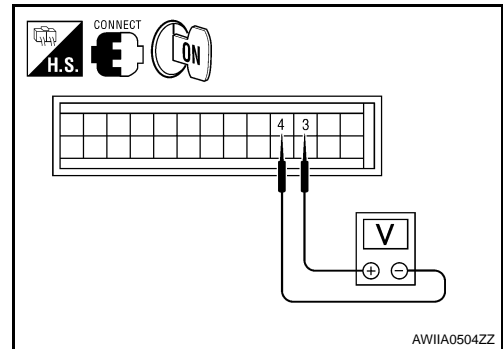

Is the inspection result normal?

- YES >> GO TO 4.  
NO >> GO TO 3.

## 2. CHECK AIR MIX DOOR MOTOR CIRCUITS FOR SHORT TO GROUND

1. Turn ignition switch OFF.
2. Disconnect the front air control harness connector.
3. Check continuity between front air control harness connector M49 terminal 3, 4 and ground.

- 3 - Ground : Continuity should not exist.**  
**4 - Ground : Continuity should not exist.**

Is the inspection result normal?

- YES >> Replace front air control. Refer to [VTL-8. "Removal and Installation"](#).  
NO >> Repair or replace harness as necessary.

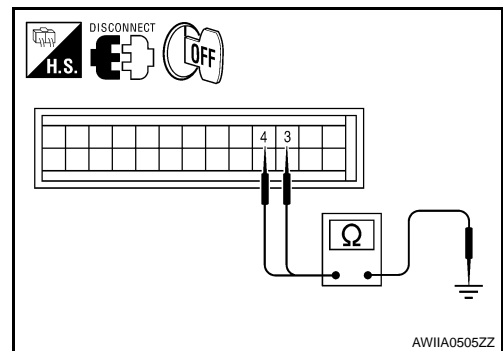

## 3. CHECK FRONT AIR CONTROL FOR POWER AND GROUND

1. Turn ignition switch ON.
2. Rotate temperature control dial to maximum hot.
3. Check voltage between front air control harness connector M49 terminal 3 and terminal 4 while rotating temperature control dial to maximum cold.

Connector	Terminals		Condition	Voltage (Approx.)
	(+)	(-)		
Front air control: M49	4	3	Rotate temp control dial	Battery voltage

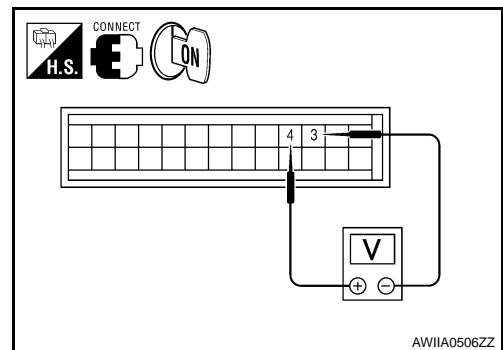

Is the inspection result normal?

- YES >> GO TO 5.  
NO >> Replace front air control. Refer to [VTL-8. "Removal and Installation"](#).

## 4. CHECK AIR MIX DOOR MOTOR CIRCUITS FOR OPEN

1. Turn ignition switch OFF.
2. Disconnect the front air control harness connector.
3. Check continuity between front air control harness connector M49 terminal 3 and terminal 4.

**Continuity should exist.**

Is the inspection result normal?

- YES >> GO TO 7.  
NO >> GO TO 6.

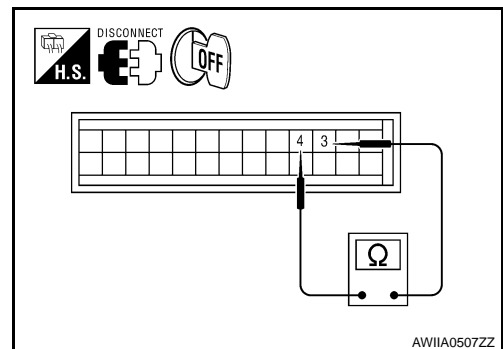

## 5. CHECK AIR MIX DOOR MOTOR CIRCUITS FOR OPEN

# AIR MIX DOOR MOTOR

[MANUAL A/C (TYPE 2)]

## < COMPONENT DIAGNOSIS >

1. Disconnect the air mix door motor harness connector.
2. Check continuity between front air control harness connector M49 (A) terminal 3, 4 and the air mix door motor harness connector M147 (B) terminal 1, 6.

**3 - 1 : Continuity should exist.**  
**4 - 6 : Continuity should exist.**

Is the inspection result normal?

- YES >> Replace air mix door motor. Refer to [VTL-20. "Removal and Installation"](#).  
 NO >> Repair or replace harness as necessary.

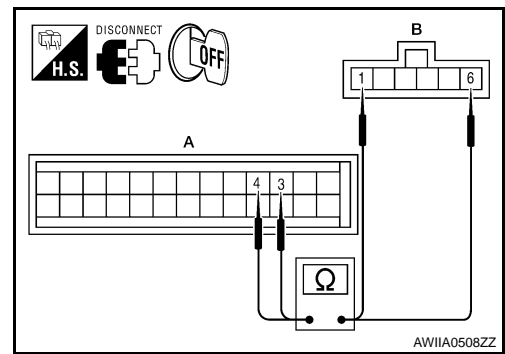

## 6. CHECK FRONT AIR CONTROL FOR PBR POWER AND GROUND

1. Reconnect front air control harness connector.
2. Turn ignition switch ON.
3. Check voltage between front air control harness connector M49 terminal 2 and 15

Connector	Terminals		Voltage (Approx.)
	(+)	(-)	
Front air control: M49	2	15	5V

Is the inspection result normal?

- YES >> GO TO 9.  
 NO >> GO TO 8.

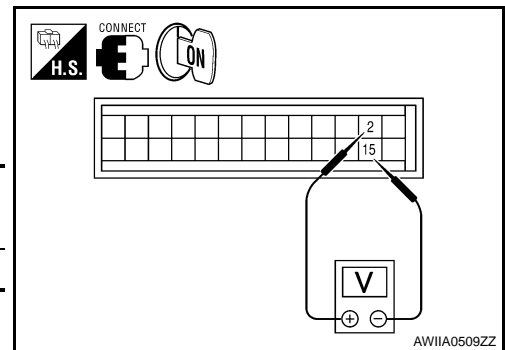

## 7. CHECK PBR REFERENCE VOLTAGE CIRCUIT FOR SHORT TO GROUND

1. Turn ignition switch OFF.
2. Disconnect the front air control harness connector.
3. Check continuity between front air control harness connector M49 terminal 2 and ground.

**Continuity should not exist.**

Is the inspection result normal?

- YES >> Replace front air control. Refer to [VTL-8. "Removal and Installation"](#).  
 NO >> Repair or replace harness as necessary.

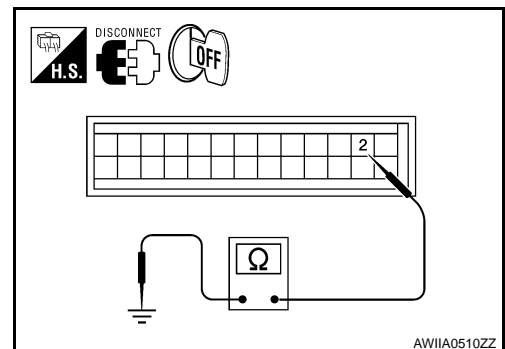

## 8. CHECK PBR REFERENCE VOLTAGE AND GROUND CIRCUITS

1. Turn ignition switch OFF.
2. Disconnect the front air control harness connector.
3. Check continuity between front air control harness connector M49 terminal 2 and 15.

**Continuity should exist.**

Is the inspection result normal?

- YES >> GO TO 11.  
 NO >> GO TO 10.

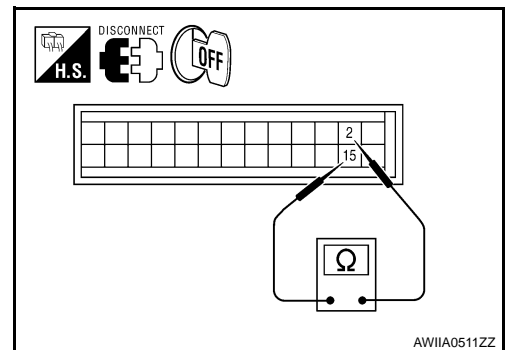

## 9. CHECK PBR REFERENCE VOLTAGE CIRCUIT FOR OPEN

# AIR MIX DOOR MOTOR

[MANUAL A/C (TYPE 2)]

## < COMPONENT DIAGNOSIS >

1. Disconnect the air mix door motor harness connector.
2. Check continuity between air mix door motor harness connector M147 (B) terminal 3, 2 and front air control harness connector M49 (A) terminal 2 and 15.

**2 - 3 : Continuity should exist.**

**15 - 2 : Continuity should exist.**

Is the inspection result normal?

YES >> Replace air mix door motor. Refer to [VTL-20, "Removal and Installation"](#).

NO >> Repair or replace harness as necessary.

## 10. CHECK PBR FEEDBACK VOLTAGE

1. Reconnect the front air control harness connector.
2. Turn ignition switch ON.
3. Check voltage between front air control harness connector M49 terminal 18 and ground while rotating temperature control dial from maximum hot to maximum cold.

**Voltage : Approx. .5V - 4.5V**

Is the inspection result normal?

YES >> GO TO 13.

NO >> GO TO 12.

## 11. CHECK PBR FEEDBACK SIGNAL CIRCUIT FOR SHORT TO GROUND

1. Turn ignition switch OFF.
2. Disconnect front air control harness connector.
3. Check continuity between front air control harness connector M49 terminal 18 and ground.

**Continuity should not exist.**

Is the inspection result normal?

YES >> Replace front air control. Refer to [VTL-8, "Removal and Installation"](#).

NO >> Repair or replace harness as necessary.

## 12. CHECK PBR FEEDBACK CIRCUIT FOR OPEN

1. Turn ignition switch OFF.
2. Disconnect the air mix door motor harness connector and front air control harness connector.
3. Check continuity between air mix door motor harness connector M147 (B) terminal 4 and front air control harness connector M49 (A) terminal 18.

**Continuity should exist.**

Is the inspection result normal?

YES >> Replace air mix door motor. Refer to [VTL-20, "Removal and Installation"](#).

NO >> Repair or replace harness as necessary.

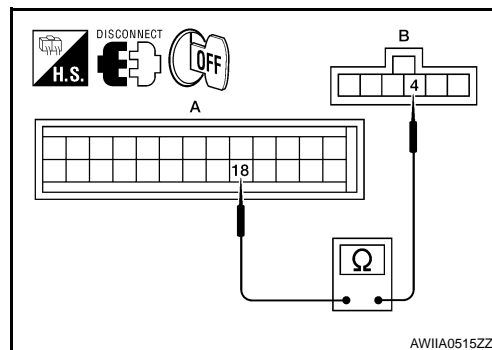
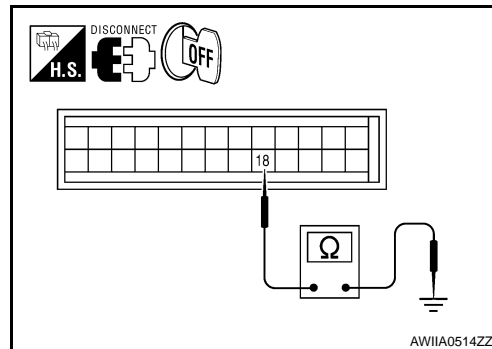
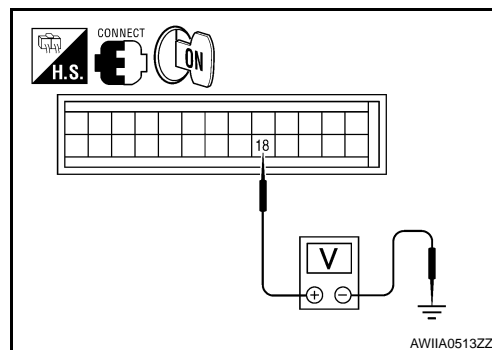
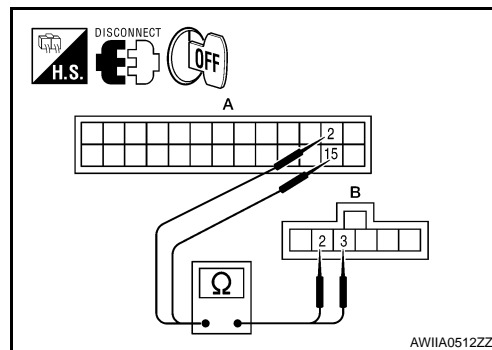

## INTAKE DOOR MOTOR

### System Description

INFOID:000000001678317

### SYSTEM DESCRIPTION

#### SYMPTOM:

- Intake door motor does not operate normally.
- Intake door does not change.

### SYSTEM DESCRIPTION

#### Component Parts

Intake door control system components are:

- Front air control
- Intake door motor (PBR built into the intake door motor)
- Intake sensor

#### System Operation

The intake door control determines the intake door position based on the position of the recirculation switch. When the recirculation switch is depressed the intake door motor rotates closing off the fresh air inlet and recirculating the cabin air. If the recirculation switch is depressed again, the intake door motor rotates in the opposite direction, again allowing fresh air into the cabin.

#### Intake Door Control Specification

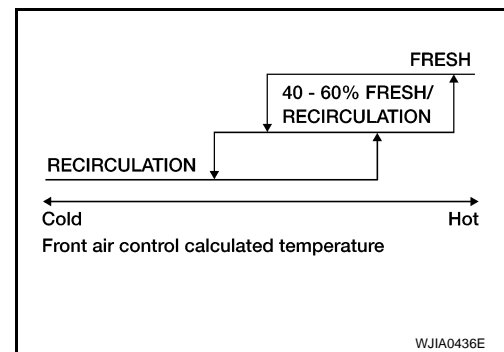

### COMPONENT DESCRIPTION

#### Intake door motor

The intake door motor is attached to the intake unit. It rotates so that air is drawn from inlets set by the front air control. Motor rotation is conveyed to a lever which activates the intake door.

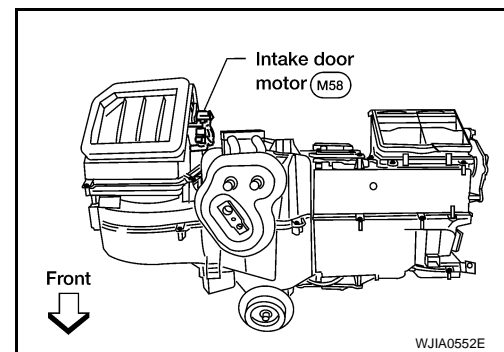





### Intake Door Motor Component Function Check

INFOID:000000001678318

#### INSPECTION FLOW

#### 1. CONFIRM SYMPTOM BY PERFORMING OPERATIONAL CHECK - REC ( )

1. Press the vent mode switch (  ).
2. Press REC (  ) switch. The REC (  ) indicator should illuminate.
3. Press REC (  ) switch again. The REC (  ) indicator should go out.
4. Listen for intake door position change (you should hear blower sound change slightly).

# INTAKE DOOR MOTOR

< COMPONENT DIAGNOSIS >

[MANUAL A/C (TYPE 2)]

Can a symptom be duplicated?

- YES >> GO TO 3.
- NO >> GO TO 2.

## 2.PERFORM COMPLETE OPERATIONAL CHECK

Perform a complete operational check and check for any symptoms. Refer to [HAC-183. "Operational Check"](#).

Can a symptom be duplicated?

- YES >> Refer to [HAC-182. "How to Perform Trouble Diagnosis For Quick And Accurate Repair"](#).
- NO >> System OK.

## 3.CHECK FOR SERVICE BULLETINS

Check for any service bulletins.

>> GO TO 4.

## 4.CHECK INTAKE DOOR OPERATION

Check and verify intake door mechanism for smooth operation.

Is the inspection result normal?

- YES >> GO TO 5.
- NO >> Repair intake door mechanism.

## 5.RECHECK FOR ANY SYMPTOMS

Perform a complete operational check for any symptoms. Refer to [HAC-183. "Operational Check"](#).

Does another symptom exist?

- YES >> Refer to [HAC-182. "How to Perform Trouble Diagnosis For Quick And Accurate Repair"](#).
- NO >> Replace front air control. Refer to [VTL-8. "Removal and Installation"](#).

## Intake Door Motor Diagnosis Procedure

INFOID:000000001678319

SYMPTOM:

- Intake door does not change.
- Intake door motor does not operate normally.

## DIAGNOSTIC PROCEDURE FOR INTAKE DOOR MOTOR

### 1.CHECK FRONT AIR CONTROL FOR POWER AND GROUND

1. Turn ignition switch ON.
2. Check voltage between front air control harness connector M49 terminal 8 and terminal 7 while placing the HVAC system into self-diagnostic mode.

Connector	Terminals		Condition	Voltage (Approx.)
	(+)	(-)		
front air control: M49	8	7	Self-diagnostic mode	Battery voltage

Is the inspection result normal?

- OK >> GO TO 4.
- NO >> GO TO 3.

### 2.CHECK INTAKE DOOR MOTOR CIRCUITS FOR SHORT TO GROUND

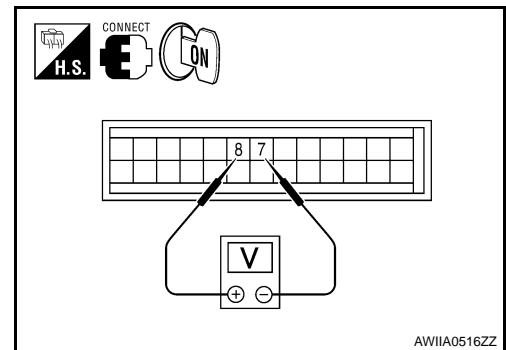



# INTAKE DOOR MOTOR

[MANUAL A/C (TYPE 2)]

## < COMPONENT DIAGNOSIS >

1. Turn ignition switch OFF.
2. Disconnect the front air control harness connector.
3. Check continuity between front air control harness connector M49 terminal 8, 7 and ground.

**8 - Ground : Continuity should not exist.**  
**7 - Ground : Continuity should not exist.**

Is the inspection result normal?

- OK >> Replace front air control. Refer to [VTL-8, "Removal and Installation"](#).  
 NO >> Repair or replace harness as necessary.

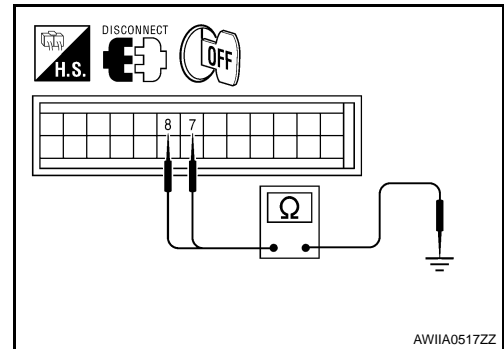

## 3. CHECK FRONT AIR CONTROL FOR GROUND AND POWER

1. Press the BACK button to back out of self-diagnostic mode.
2. Check voltage between front air control harness connector M49 terminal 8 and terminal 7 while placing the HVAC system into self-diagnostic mode.

Connector	Terminals		Condition	Voltage (Approx.)
	(+)	(-)		
front air control: M49	7	8	Self-diagnostic mode	Battery voltage

Is the inspection result normal?

- OK >> GO TO 5.  
 NO >> Replace front air control. Refer to [VTL-8, "Removal and Installation"](#).

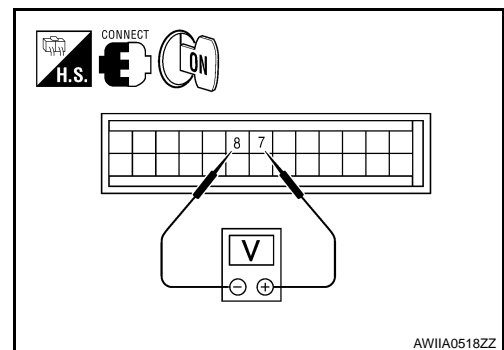

## 4. CHECK INTAKE DOOR MOTOR AND CIRCUITS FOR OPEN

1. Turn ignition switch OFF.
2. Disconnect the front air control harness connector.
3. Check continuity between front air control harness connector M49 terminal 8 and terminal 7.

**Continuity should exist.**

Is the inspection result normal?

- OK >> Replace intake door motor. Refer to [VTL-18, "Removal and Installation"](#).  
 NO >> GO TO 6.

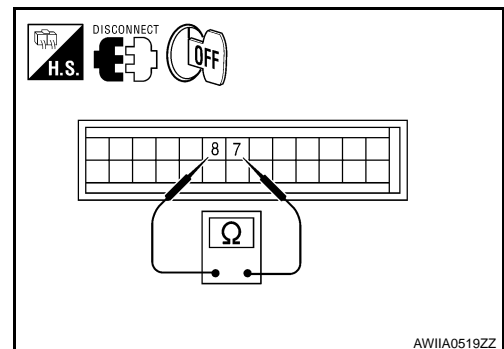

## 5. CHECK INTAKE DOOR MOTOR CIRCUITS FOR OPEN

1. Disconnect the intake door motor harness connector.
2. Check continuity between front air control harness connector M49 (A) terminal 7, 8 and the intake door motor harness connector M58 (B) terminal 1, 6.

**8 - 6 : Continuity should exist.**  
**7 - 1 : Continuity should exist.**

Is the inspection result normal?

- YES >> Replace intake door motor. Refer to [VTL-18, "Removal and Installation"](#).  
 NO >> Repair or replace harness as necessary.

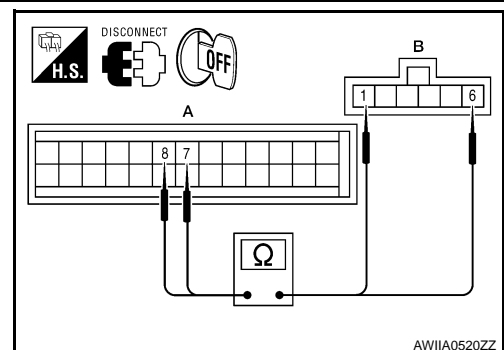

# DEFROSTER DOOR MOTOR CIRCUIT

< COMPONENT DIAGNOSIS >

[MANUAL A/C (TYPE 2)]

## DEFROSTER DOOR MOTOR CIRCUIT

### System Description

INFOID:000000001678320

### SYSTEM DESCRIPTION

#### Component Parts

Defroster door control system components are:

- Front air control
- Defroster door motor
- PBR (Built into defroster door motor)
- Intake sensor

#### System Operation

The front air control determines defroster door position based on the position of the defroster switch. When the defroster switch is depressed, the defroster door motor rotates directing air to the defroster ducts. When any mode other than defroster is selected, the defroster motor rotates in the opposite direction closing off air flow to the defroster ducts.

### COMPONENT DESCRIPTION

#### Defroster door motor

The defroster door motor is attached to the front heater & cooling unit assembly. The front air control sends a voltage to rotate to the defroster door directing the air flow either to the defroster ducts, or to the floor ducts, depending on which way the voltage and ground are applied to the motor leads. Motor rotation is conveyed to a lever which activates the defroster door.

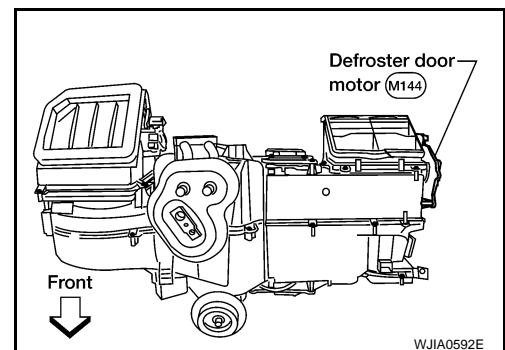

### Defroster Door Motor Component Function Check

INFOID:000000001678321

### INSPECTION FLOW

#### 1. CONFIRM SYMPTOM BY PERFORMING OPERATIONAL CHECK - DEFROSTER DOOR

1. Select vent (☰) mode.
2. Rotate mode control dial to defrost mode (☰).
3. Listen for defroster door position change (blower sound should change slightly).

#### Can the symptom be duplicated?

- YES >> GO TO 3.  
NO >> GO TO 2.

#### 2. CHECK FOR ANY SYMPTOMS

Perform a complete operational check for any symptoms. Refer to [HAC-183, "Operational Check"](#).

#### Does another symptom exist?

- YES >> Refer to [HAC-182, "How to Perform Trouble Diagnosis For Quick And Accurate Repair"](#).  
NO >> SYSTEM OK.

#### 3. CHECK FOR SERVICE BULLETINS

Check for any service bulletins.

>> GO TO 4.

#### 4. CHECK DEFROSTER DOOR MOTOR

# DEFROSTER DOOR MOTOR CIRCUIT

< COMPONENT DIAGNOSIS >

[MANUAL A/C (TYPE 2)]

Perform diagnostic procedure for defroster door motor. Refer to [HAC-210. "Defroster Door Motor Component Function Check"](#).

Is the inspection result normal?

YES >> GO TO 5.

NO >> Repair PBR circuit or replace defroster door motor. Refer to [VTL-17. "Removal and Installation"](#).

## 5.CHECK DEFROSTER DOOR OPERATION

Check and verify defroster door mechanism for smooth operation.

Is the inspection result normal?

YES >> Replace defroster door motor. Refer to [VTL-17. "Removal and Installation"](#).

NO >> Repair defroster door mechanism.

## Defroster Door Motor Diagnosis Procedure

INFOID:000000001678322

SYMPTOM:

- Defroster door does not change.
- Defroster door motor does not operate normally.

## DIAGNOSTIC PROCEDURE FOR DEFROSTER DOOR MOTOR

### 1.CHECK FRONT AIR CONTROL FOR POWER AND GROUND

1. Turn ignition switch ON.
2. Rotate the mode control dial to defrost mode (☃).
3. Check voltage between front air control harness connector M49 terminal 20 and terminal 19 and then press the defroster switch (☃) again.

Connector	Terminals		Condition	Voltage (Approx.)
	(+)	(-)		
Front air control: M49	20	19	Press defroster switch	Battery voltage

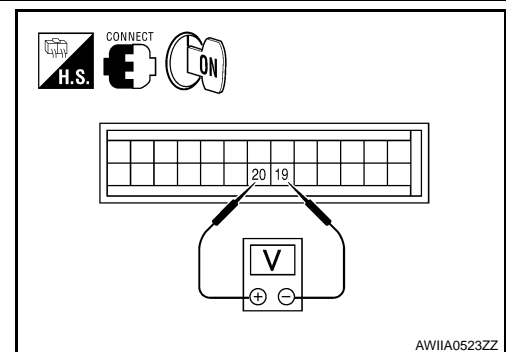

Is the inspection result normal?

YES >> GO TO 4.

NO >> GO TO 3.

### 2.CHECK DEFROSTER DOOR MOTOR CIRCUITS FOR SHORT TO GROUND

1. Turn ignition switch OFF.
2. Disconnect the front air control harness connector.
3. Check continuity between front air control harness connector M49 terminal 19, 20 and ground.

**19 - Ground : Continuity should not exist.**

**20 - Ground : Continuity should not exist.**

Is the inspection result normal?

YES >> Replace front air control. Refer to [VTL-8. "Removal and Installation"](#)

NO >> Repair or replace harness as necessary.

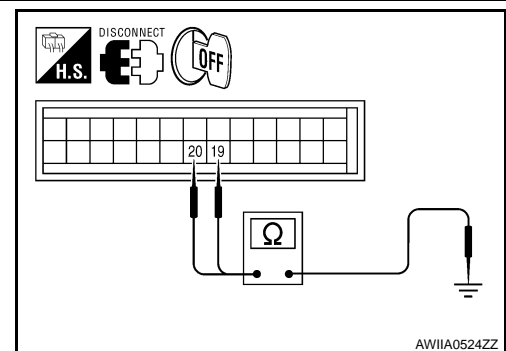

### 3.CHECK FRONT AIR CONTROL FOR GROUND AND POWER



# DEFROSTER DOOR MOTOR CIRCUIT

## < COMPONENT DIAGNOSIS >

[MANUAL A/C (TYPE 2)]

1. Press the defroster switch (  ).
2. Check voltage between front air control harness connector M49 terminal 19 and terminal 20 and the press the defroster switch (  ) again.

Connector	Terminals		Condition	Voltage (Approx.)
	(+)	(-)		
Front air control: M49	19	20	Press defroster switch	Battery voltage

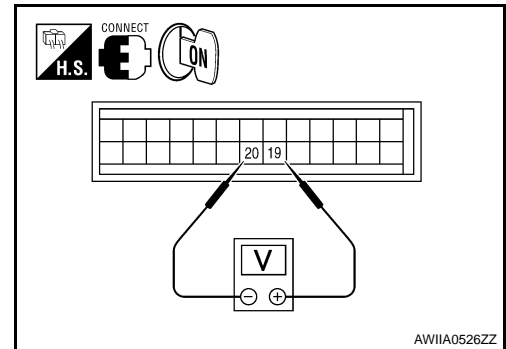

Is the inspection result normal?

YES >> GO TO 5.

NO >> Replace front air control. Refer to [VTL-8. "Removal and Installation"](#).

## 4. CHECK DEFROSTER DOOR MOTOR AND CIRCUITS FOR OPEN

1. Turn ignition switch OFF.
2. Disconnect the front air control harness connector.
3. Check continuity between front air control harness connector M49 terminal 19 and terminal 20.

**Continuity should exist.**

Is the inspection result normal?

YES >> GO TO 7.

NO >> GO TO 6.

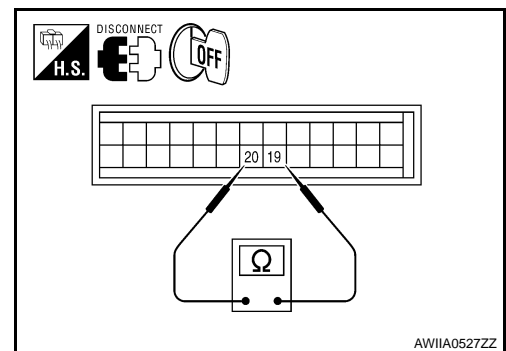

## 5. CHECK DEFROSTER DOOR MOTOR CIRCUITS FOR OPEN

1. Disconnect the defroster door motor harness connector.
2. Check continuity between front air control harness connector M49 terminal 19, 20 and the defroster door motor harness connector M144 terminal 1, 6.

**19 - 1 : Continuity should exist.**

**20 - 6 : Continuity should exist.**

Is the inspection result normal?

YES >> Replace defroster door motor. Refer to [VTL-17. "Removal and Installation"](#).

NO >> Repair or replace harness as necessary.

## 6. CHECK FRONT AIR CONTROL FOR PBR POWER AND GROUND

1. Reconnect front air control harness connector.
2. Turn ignition switch ON.
3. Check voltage between front air control harness connector M49 terminal 2 and 15.

Connector	Terminals		Voltage (Approx.)
	(+)	(-)	
Front air control: M50, M49	2	15	5V

Is the inspection result normal?

YES >> GO TO 9.

NO >> GO TO 8.

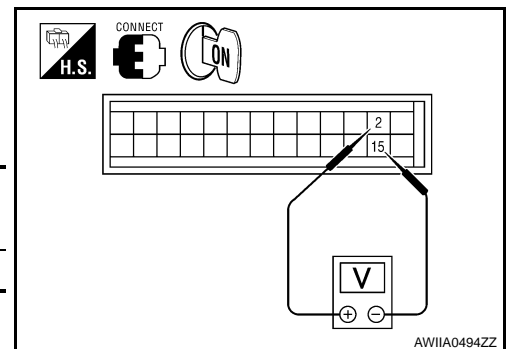

## 7. CHECK PBR REFERENCE VOLTAGE CIRCUIT FOR SHORT TO GROUND

# DEFROSTER DOOR MOTOR CIRCUIT

[MANUAL A/C (TYPE 2)]

## < COMPONENT DIAGNOSIS >

1. Turn ignition switch OFF.
2. Disconnect the front air control harness connector.
3. Check continuity between front air control harness connector M49 terminal 2 and ground.

**Continuity should not exist.**

Is the inspection result normal?

- YES >> Replace front air control. Refer to [VTL-8, "Removal and Installation"](#).
- NO >> Repair or replace harness as necessary.

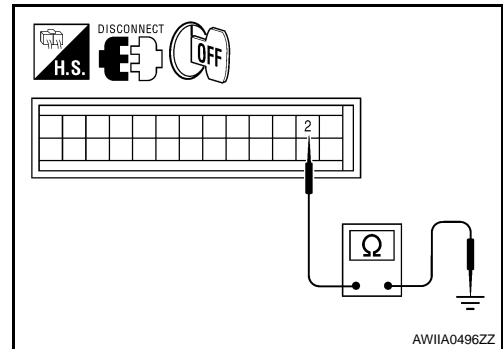

## 8. CHECK PBR REFERENCE VOLTAGE AND GROUND CIRCUITS

1. Turn ignition switch OFF.
2. Disconnect the front air control harness connector.
3. Check continuity between front air control harness connector M49 terminal 2 and 15.

**Continuity should exist.**

Is the inspection result normal?

- YES >> GO TO 11.
- NO >> GO TO 10.

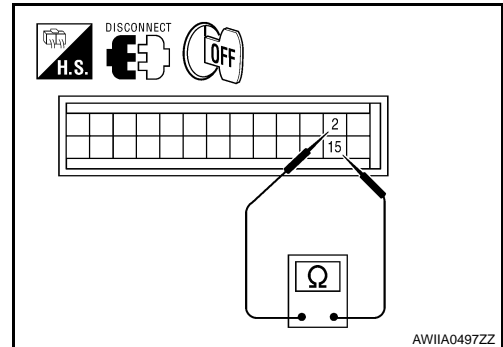

## 9. CHECK PBR REFERENCE VOLTAGE CIRCUIT FOR OPEN

1. Disconnect the defroster door motor harness connector.
2. Check continuity between defroster door motor harness connector M144 (B) terminal 3, 2 and front air control harness connector M49 (A) terminal 2, and 15.

**2 - 3 : Continuity should exist.**

**15 - 2 : Continuity should exist.**

Is the inspection result normal?

- YES >> Replace defroster door motor. Refer to [VTL-17, "Removal and Installation"](#).
- NO >> Repair or replace harness as necessary.

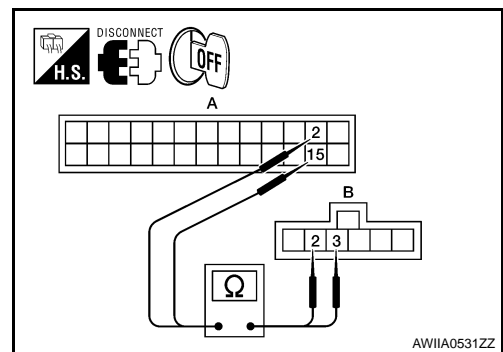

## 10. CHECK PBR FEEDBACK VOLTAGE

1. Reconnect the front air control harness connector.
2. Turn ignition switch ON.
3. Check voltage between front air control harness connector M49 terminal 25 and ground while cycling defroster switch on and off.

**Voltage : Approx. 1V - 4.5V**

Is the inspection result normal?

- YES >> GO TO 13.
- NO >> GO TO 12.

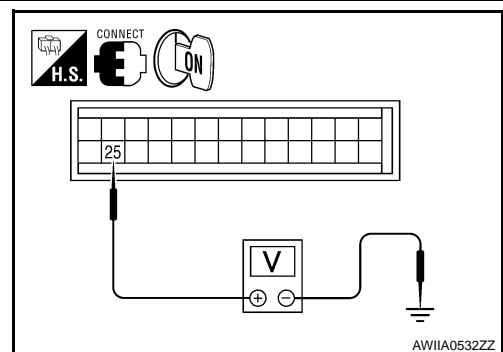

## 11. CHECK PBR FEEDBACK SIGNAL CIRCUIT FOR SHORT TO GROUND

# DEFROSTER DOOR MOTOR CIRCUIT

[MANUAL A/C (TYPE 2)]

## < COMPONENT DIAGNOSIS >

1. Turn ignition switch OFF.
2. Disconnect front air control harness connector.
3. Check continuity between front air control harness connector M49 terminal 25 and ground.

**Continuity should not exist.**

Is the inspection result normal?

YES >> Replace front air control. Refer to [VTL-8, "Removal and Installation"](#).

NO >> Repair or replace harness as necessary.

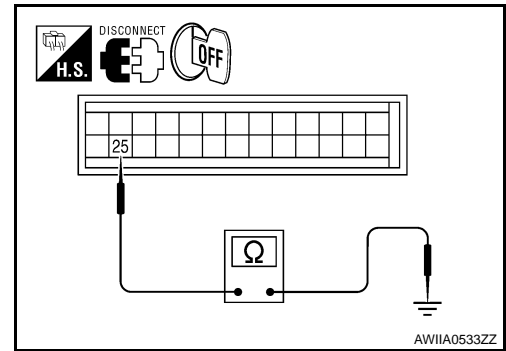

## 12. CHECK PBR FEEDBACK CIRCUIT FOR OPEN

1. Turn ignition switch OFF.
2. Disconnect the defroster door motor harness connector and front air control harness connector.
3. Check continuity between defroster door motor harness connector M144 (B) terminal 4 and front air control harness connector M49 (A) terminal 25

**Continuity should exist.**

Is the inspection result normal?

YES >> Replace defroster door motor. Refer to [VTL-17, "Removal and Installation"](#).

NO >> Repair or replace harness as necessary.

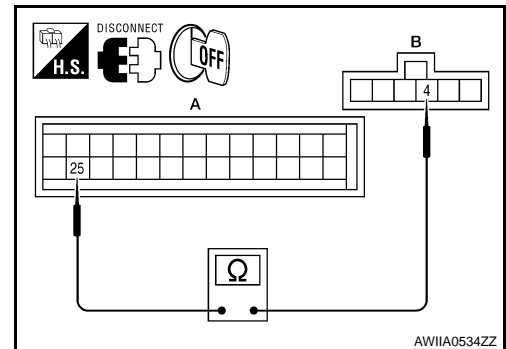

# BLOWER MOTOR CONTROL SYSTEM

< COMPONENT DIAGNOSIS >

[MANUAL A/C (TYPE 2)]

## BLOWER MOTOR CONTROL SYSTEM

### System Description

INFOID:000000001678323

### SYSTEM DESCRIPTION

#### Component Parts

Blower speed control system components are:

- Front air control
- Variable blower control
- Front blower motor relay
- Front blower motor
- Intake sensor

#### System Operation

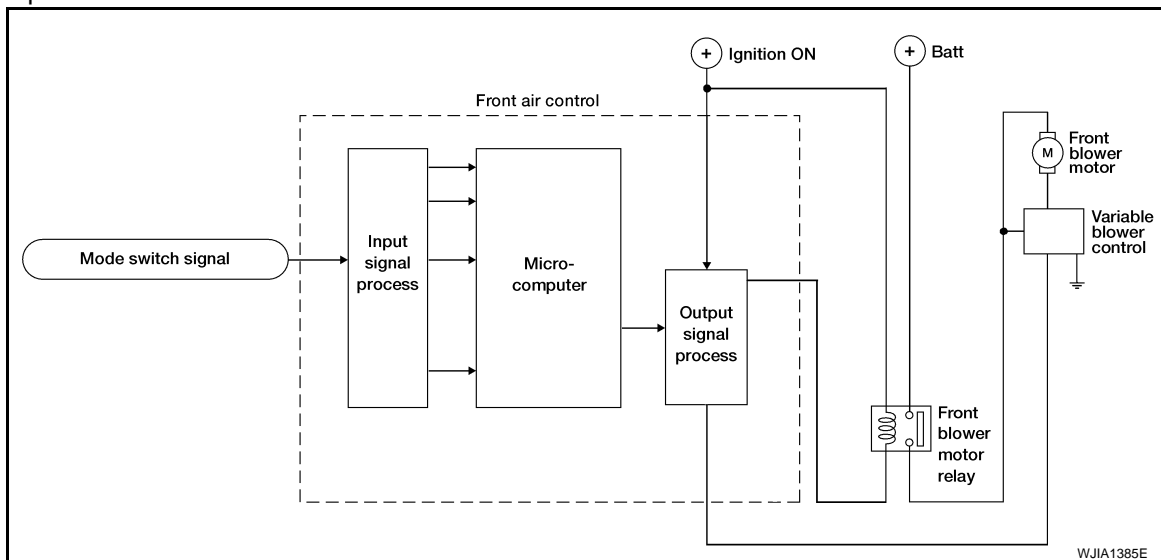

### COMPONENT DESCRIPTION

#### Variable Blower Control

The variable blower control is located on the cooling unit. The variable blower control receives a gate voltage from the front air control to steplessly maintain the blower motor voltage in the 0 to 5 volt range (approx.).

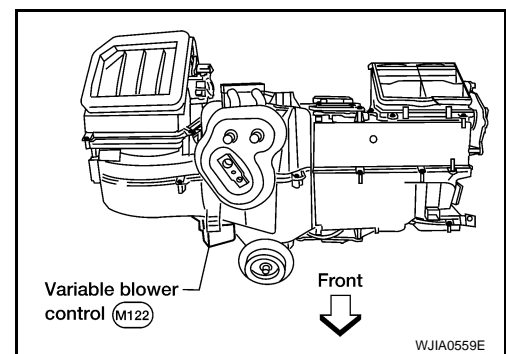

### Front Blower Motor Component Function Check

INFOID:000000001678324

#### INSPECTION FLOW

##### 1. CONFIRM SYMPTOM BY PERFORMING OPERATIONAL CHECK - FRONT BLOWER

1. Rotate the blower control dial clockwise once. Blower motor should operate in low speed.
2. Rotate the blower control dial clockwise, and continue checking blower speed until all speeds are checked.

#### Can the symptom be duplicated?

- YES >> GO TO 3.  
NO >> GO TO 2.

A

B

C

D

E

F

G

H

HAC

J

K

L

M

N

O

P

# BLOWER MOTOR CONTROL SYSTEM

< COMPONENT DIAGNOSIS >

[MANUAL A/C (TYPE 2)]

## 2. CHECK FOR ANY SYMPTOMS

Perform a complete operational check for any symptoms. Refer to [HAC-183. "Operational Check"](#).

Does another symptom exist?

YES >> Refer to [HAC-182. "How to Perform Trouble Diagnosis For Quick And Accurate Repair"](#).

NO >> System OK.

## 3. CHECK FOR SERVICE BULLETINS

Check for any service bulletins.

>> GO TO 4.

## 4. CHECK BLOWER MOTOR OPERATION

Check and verify blower motor operates manually in all speeds.

Does blower motor operate in all speeds?

YES >> GO TO 5.

NO >> Refer to [HAC-216. "Front Blower Motor Diagnosis Procedure"](#).

## 5. CHECK ENGINE COOLANT TEMPERATURE SENSOR CIRCUIT

Check engine coolant temperature sensor circuit. Refer to [EC-125. "Diagnosis Procedure"](#).

Is the inspection results normal?

YES >> GO TO 6.

NO >> Replace engine coolant temperature sensor.

## 6. RECHECK FOR ANY SYMPTOMS

Perform a complete operational check for any symptoms. Refer to [HAC-183. "Operational Check"](#).

Does another symptom exist?

YES >> Refer to [HAC-182. "How to Perform Trouble Diagnosis For Quick And Accurate Repair"](#).

NO >> Replace front air control. Refer to [VTL-8. "Removal and Installation"](#).

## Front Blower Motor Diagnosis Procedure

INFOID:000000001678325

SYMPTOM: Blower motor operation is malfunctioning.

### DIAGNOSTIC PROCEDURE FOR BLOWER MOTOR

SYMPTOM: Blower motor operation is malfunctioning under starting blower speed control.

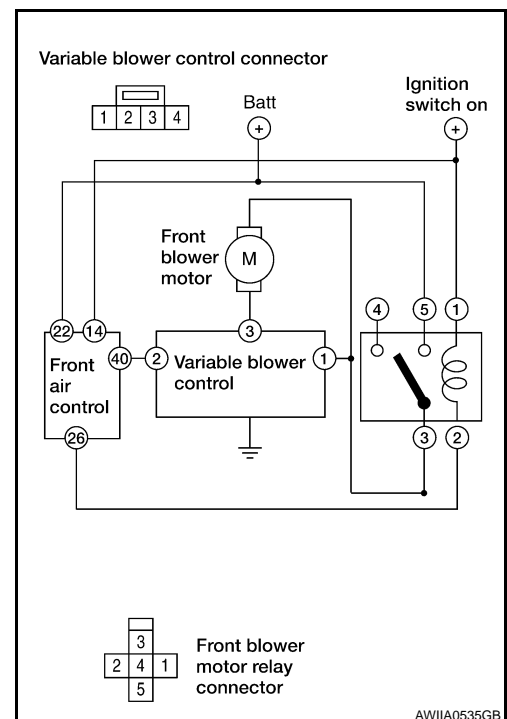



# BLOWER MOTOR CONTROL SYSTEM

< COMPONENT DIAGNOSIS >

[MANUAL A/C (TYPE 2)]

## 1. CHECK FUSES

Check 20A fuses [No. 24 and 27 (Located in the fuse and fusible link box)]. For fuse layout. Refer to [PG-66, "Terminal Arrangement"](#).

**Fuses are good.**

Is the inspection result normal?

- YES >> GO TO 3.
- NO >> GO TO 9.

## 2. CHECK FRONT BLOWER MOTOR POWER SUPPLY CIRCUIT

1. Turn ignition switch OFF.
2. Disconnect front blower motor connector.
3. Turn ignition switch ON.
4. Press the A/C switch.
5. Rotate blower control dial to maximum speed.
6. Check voltage between front blower motor harness connector M62 terminal 2 and ground.

**2 - Ground : Battery voltage**

Is the inspection result normal?

- YES >> GO TO 10.
- NO >> GO TO 3.

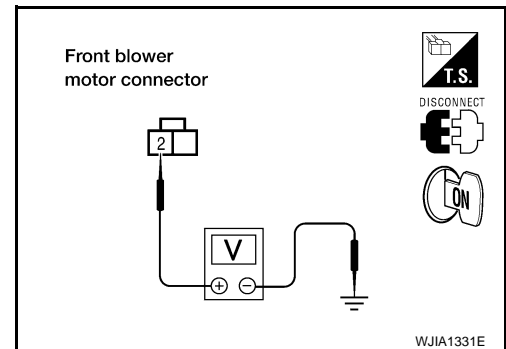

## 3. CHECK FRONT BLOWER MOTOR RELAY (SWITCH SIDE) POWER SUPPLY CIRCUIT

1. Turn ignition switch OFF.
2. Disconnect front blower motor relay.
3. Check voltage between front blower motor relay harness connector M107 terminal 5 and ground.

**5 - Ground : Battery voltage**

Is the inspection result normal?

- YES >> GO TO 4.
- NO >> Repair harness or connector.

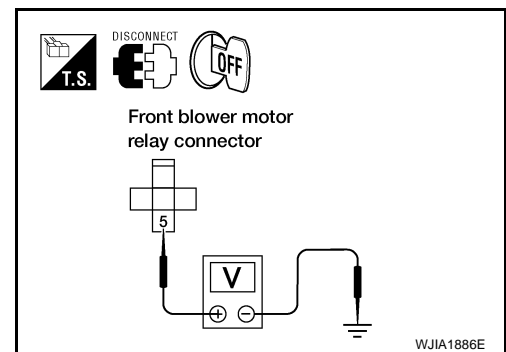

## 4. CHECK FRONT BLOWER MOTOR RELAY

Turn ignition switch OFF.

Check front blower motor relay. Refer to [HAC-219, "Front Blower Motor Component Inspection"](#).

Is the inspection result normal?

- YES >> GO TO 5.
- NO >> Replace front blower motor relay.

## 5. CHECK FRONT BLOWER MOTOR RELAY (SWITCH SIDE) CIRCUIT FOR OPEN

Check continuity between front blower motor relay harness connector M107 terminal 3 and front blower motor harness connector M62 terminal 2.

**3 - 2 : Continuity should exist.**

Is the inspection result normal?

- YES >> GO TO 6.
- NO >> Repair harness or connector.

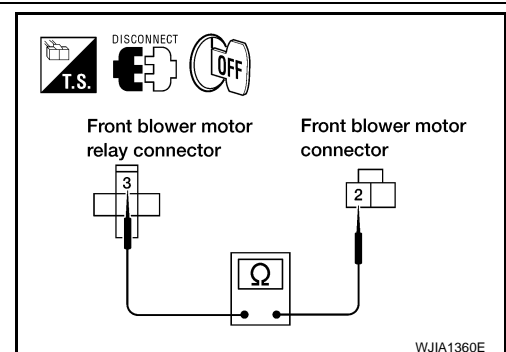

## 6. CHECK VARIABLE BLOWER CONTROL POWER SUPPLY CIRCUIT FOR OPEN

# BLOWER MOTOR CONTROL SYSTEM

[MANUAL A/C (TYPE 2)]

## < COMPONENT DIAGNOSIS >

1. Disconnect variable blower control harness connector.
2. Check continuity between front blower motor relay harness connector M107 (A) terminals 3 and variable blower control harness connector M122 (B) terminal 1.

**3 - 1** : Continuity should exist.

Is the inspection result normal?

- YES >> GO TO 7.  
NO >> Repair harness or connector.

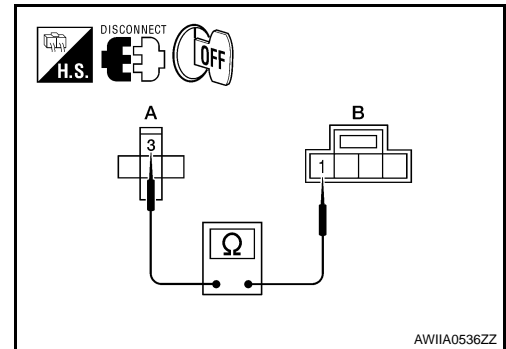

## 7. CHECK VARIABLE BLOWER CONTROL SIGNAL CIRCUIT

1. Disconnect front air control connector.
2. Check continuity between front air control harness connector M49 (B) terminal 40 and variable blower control harness connector M122 (A) terminal 2.

**40 - 2** : Continuity should exist.

Is the inspection result normal?

- YES >> GO TO 8.  
NO >> Repair harness or connector.

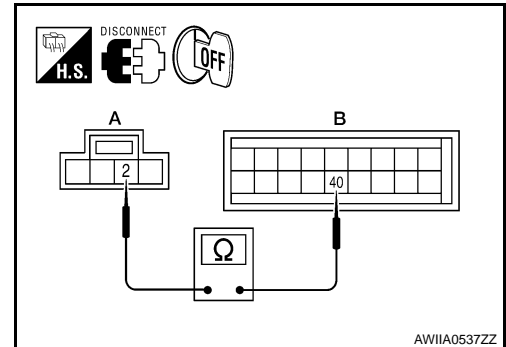

## 8. CHECK FRONT BLOWER MOTOR RELAY (COIL SIDE) POWER SUPPLY

1. Turn ignition switch ON.
2. Check voltage between front blower motor relay harness connector M107 terminal 1 and ground.

**1 - Ground** : Battery voltage

Is the inspection result normal?

- YES >> GO TO 9.  
NO >> Repair front blower motor ground circuit or connector.

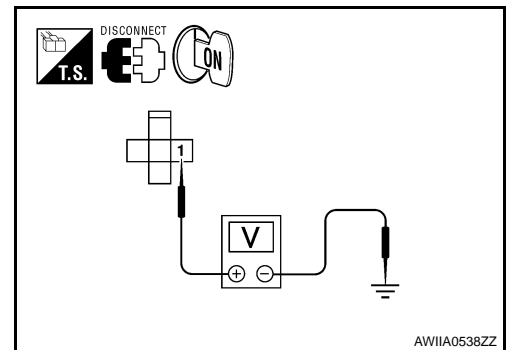

## 9. REPLACE FUSES

1. Replace fuses.
2. Activate the front blower motor.

Does the fuse blow?

- YES >> GO TO 10.  
NO >> Inspection End.

## 10. CHECK FRONT BLOWER MOTOR POWER SUPPLY CIRCUIT FOR SHORT

1. Turn ignition switch OFF.
2. Disconnect front blower motor connector and variable blower control connector.
3. Check continuity between variable blower control harness connector M122 terminal 1 and ground.

**1 - Ground** : Continuity should not exist.

Is the inspection result normal?

- YES >> GO TO 11.  
NO >> Repair harness or connector.

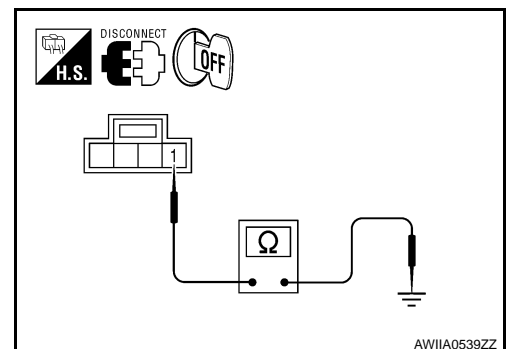

## 11. CHECK VARIABLE BLOWER CONTROL SIGNAL CIRCUIT

# BLOWER MOTOR CONTROL SYSTEM

[MANUAL A/C (TYPE 2)]

## < COMPONENT DIAGNOSIS >

1. Disconnect front air control connector.
2. Check continuity between front air control harness connector M49 (B) terminal 40 and variable blower control harness connector M122 (A) terminal 2.

**40 - 2** : Continuity should exist.

Is the inspection result normal?

YES >> GO TO 12.

NO >> Repair harness or connector.

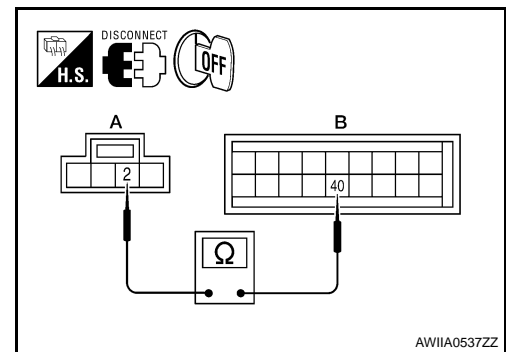

## 12. CHECK FRONT BLOWER MOTOR

Check front blower motor. Refer to [HAC-215, "Front Blower Motor Component Function Check"](#).

Is the inspection result normal?

YES >> GO TO 13.

NO >> Replace front blower motor. Refer to [VTL-12, "Removal and Installation"](#).

## 13. CHECK BLOWER MOTOR GROUND CIRCUIT

Check continuity between front blower motor harness connector M62 terminal 1 and variable blower control harness connector M122 terminal 3.

**1 - 3** : Continuity should exist.

Is the inspection result normal?

YES >> GO TO 14.

NO >> Repair harness or connector.

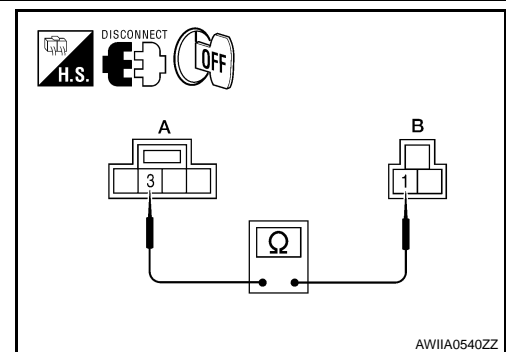

## 14. CHECK VARIABLE BLOWER CONTROL GROUND CIRCUIT

Check continuity between variable blower control harness connector M122 terminal 4 and ground.

**4 - Ground** : Continuity should exist.

Is the inspection result normal?

YES >> Replace variable blower control. Refer to [VTL-22, "Removal and Installation"](#).

NO >> Repair harness or connector.

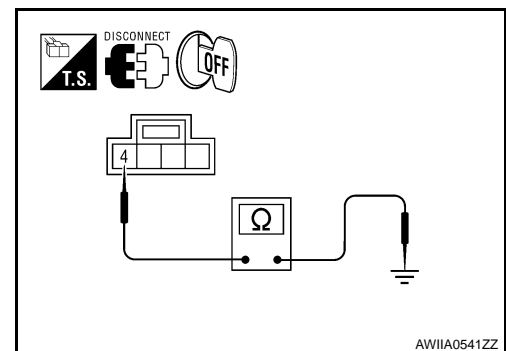

Front Blower Motor Component Inspection

INFOID:000000001678326

COMPONENT INSPECTION

# BLOWER MOTOR CONTROL SYSTEM

## < COMPONENT DIAGNOSIS >

[MANUAL A/C (TYPE 2)]

Check continuity between terminals by supplying 12 volts and ground to coil side terminals of relay.

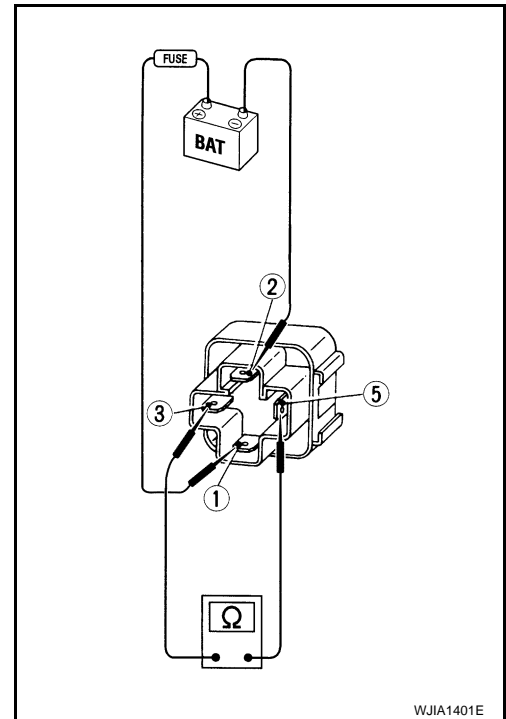

### Front Blower Motor

Confirm smooth rotation of the blower motor.

- Ensure that there are no foreign particles inside the blower unit.
- Apply 12 volts to terminal 2 and ground to terminal 1 and verify that the motor operates freely and quietly.

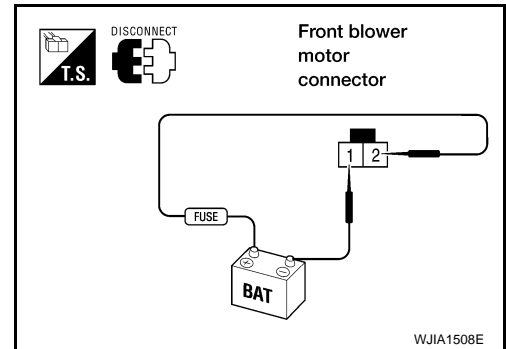

## MAGNET CLUTCH

### System Description

INFOID:000000001678327

### SYSTEM DESCRIPTION

The front air control controls compressor operation based on ambient and intake temperature and a signal from ECM.

#### Low Temperature Protection Control

The front air control will turn the compressor ON or OFF as determined by a signal detected by the intake sensor.

When intake air temperature is higher than the preset value, the compressor turns ON. The compressor turns OFF when intake air temperature is lower than the preset value.

### Magnet Clutch Component Function Check

INFOID:000000001678328

### INSPECTION FLOW

#### 1.CONFIRM SYMPTOM BY PERFORMING OPERATIONAL CHECK - MAGNET CLUTCH

1. Turn ignition switch ON.
2. Turn the blower control dial to low speed and press the A/C switch.
3. Rotate mode control dial to vent mode (↺).
4. Confirm that the compressor clutch engages (sound or visual inspection). (Discharge air and blower speed will depend on ambient, in-vehicle and set temperatures.)

#### Can the symptom be duplicated?

- YES >> GO TO 3.  
NO >> GO TO 2.

#### 2.CHECK FOR ANY SYMPTOMS

Perform a complete operational check for any symptoms. Refer to [HAC-183, "Operational Check"](#).

#### Does another symptom exist?

- YES >> Refer to [HAC-182, "How to Perform Trouble Diagnosis For Quick And Accurate Repair"](#).  
NO >> System OK.

#### 3.CHECK FOR SERVICE BULLETINS

Check for any service bulletins.

>> GO TO 4.

#### 4.CHECK INTAKE SENSOR

Check and verify intake sensor circuit. Refer to [HAC-228, "Intake Sensor Diagnosis Procedure"](#).

>> GO TO 5.

#### 5.RECHECK FOR ANY SYMPTOMS

Perform a complete operational check for any symptoms. Refer to [HAC-183, "Operational Check"](#).

#### Does another symptom exist?

- YES >> Refer to [HAC-182, "How to Perform Trouble Diagnosis For Quick And Accurate Repair"](#).  
NO >> Replace front air control. Refer to [VTL-8, "Removal and Installation"](#).

### Magnet Clutch Diagnosis Procedure

INFOID:000000001678329

### DIAGNOSTIC PROCEDURE FOR MAGNET CLUTCH

A  
B  
C  
D  
E  
F  
G  
H  
HAC  
J  
K  
L  
M  
N  
O  
P

# MAGNET CLUTCH

< COMPONENT DIAGNOSIS >

[MANUAL A/C (TYPE 2)]

SYMPTOM: Magnet clutch does not engage when A/C switch is ON.

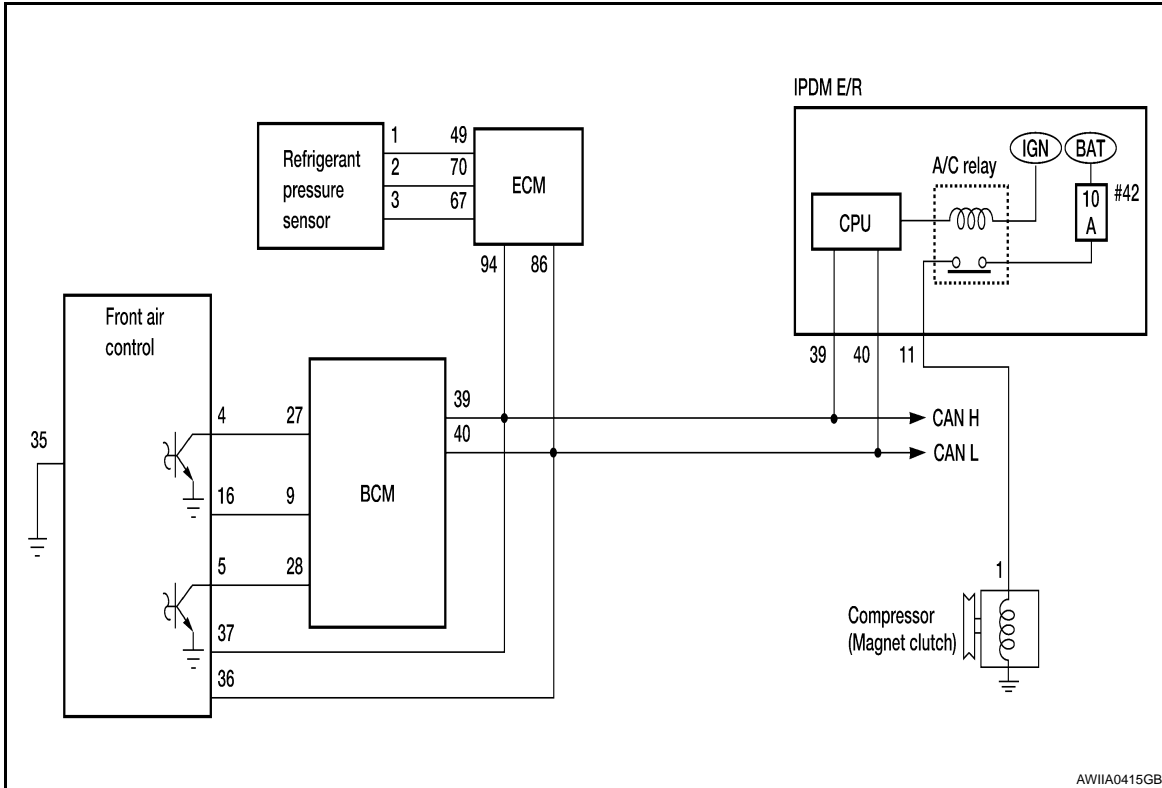

## 1. CHECK INTAKE SENSOR CIRCUIT

Check intake sensors. Refer to [HAC-229, "Intake Sensor Component Inspection"](#).

Is the inspection result normal?

YES >> GO TO 2.

NO >> Check malfunctioning intake sensor. Refer to [HAC-228, "Intake Sensor Diagnosis Procedure"](#).

## 2. PERFORM AUTO ACTIVE TEST

Refer to [PCS-10, "Diagnosis Description"](#).

Does magnet clutch operate?

YES >> •  WITH CONSULT-III  
GO TO 5.

•  WITHOUT CONSULT-III  
GO TO 6.

NO >> Check 10A fuse (No. 42, located in IPDM E/R), and GO TO 3.

## 3. CHECK CIRCUIT CONTINUITY BETWEEN IPDM E/R AND COMPRESSOR

1. Turn ignition switch OFF.
2. Disconnect IPDM E/R connector and compressor (magnet clutch) connector.
3. Check continuity between IPDM E/R harness connector E119 terminal 11 and A/C compressor harness connector F3 terminal 1.

11 – 1

: Continuity should exist.

Is the inspection result normal?

YES >> GO TO 4.

NO >> Repair harness or connector.

## 4. CHECK MAGNET CLUTCH CIRCUIT

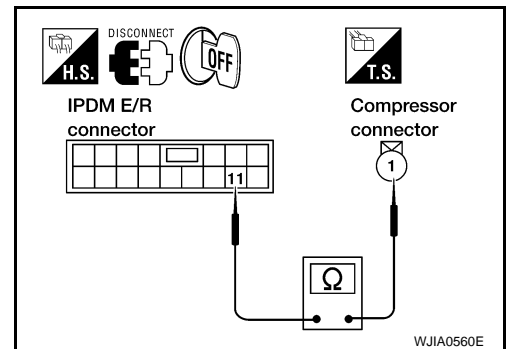

# MAGNET CLUTCH

## < COMPONENT DIAGNOSIS >

[MANUAL A/C (TYPE 2)]

Check for operation sound when applying battery voltage direct current to terminal.

Is the inspection result normal?

- YES >> Replace IPDM E/R. Refer to [PCS-30, "Removal and Installation of IPDM E/R"](#).
- NO >> Replace magnet clutch. Refer to [HA-34, "Removal and Installation for Compressor Clutch"](#).

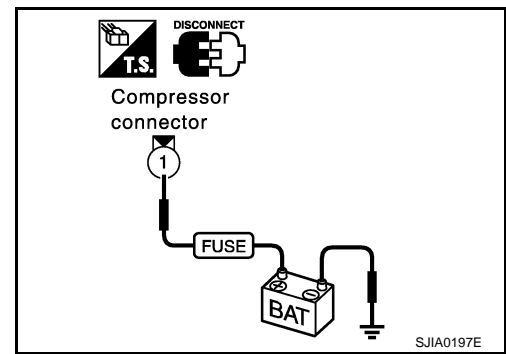

### 5. CHECK BCM INPUT (COMPRESSOR ON) SIGNAL

Check compressor ON/OFF signal. Refer to [HAC-195, "CONSULT-III Function \(BCM\)"](#).

**A/C SW ON : COMP ON SIG ON**  
**A/C SW OFF : COMP ON SIG OFF**

Is the inspection result normal?

- YES >> GO TO 8.
- NO >> GO TO 6.

### 6. CHECK CIRCUIT CONTINUITY BETWEEN BCM AND FRONT AIR CONTROL

1. Turn ignition switch OFF.
2. Disconnect BCM connector and front air control connector.
3. Check continuity between BCM harness connector M18 (A) terminal 27 and front air control harness connector M49 (B) terminal 12.

**27 - 12 Continuity should exist.**

Is the inspection result normal?

- YES >> GO TO 7.
- NO >> Repair harness or connector.

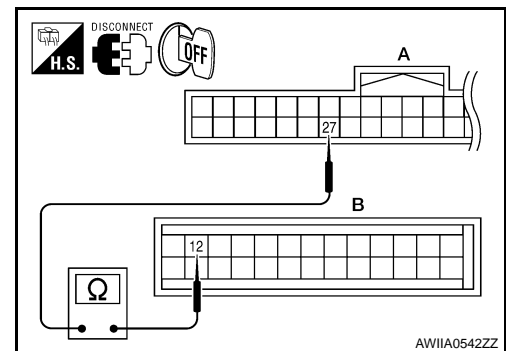

### 7. CHECK VOLTAGE FOR FRONT AIR CONTROL (A/C COMPRESSOR ON SIGNAL)

1. Reconnect BCM connector and front air control connector.
2. Turn ignition switch ON.
3. Check voltage between front air control harness connector M49 terminal 12 and ground.

Terminals		Condition	Voltage
(+)	(-)		
front air control connector	Terminal No.		
M49	12	Ground	A/C switch: ON Approx. 0V
			A/C switch: OFF Approx. 5V

Is the inspection result normal?

- YES >> GO TO 8.
- NO-1 >> If the voltage is approx. 5V when A/C switch is ON, replace front air control. Refer to [VTL-8, "Removal and Installation"](#).
- NO-2 >> If the voltage is approx. 0V when A/C switch is OFF, replace BCM. Refer to [BCS-50, "Removal and Installation"](#).

### 8. CHECK REFRIGERANT PRESSURE SENSOR

1. Start engine.

# MAGNET CLUTCH

## < COMPONENT DIAGNOSIS >

[MANUAL A/C (TYPE 2)]

- Check voltage between ECM harness connector F54 terminal 70 and ground.

Terminals		(-)	Condition	Voltage
(+) Terminal No.				
ECM connector	Terminal No.			
F54	70	Ground	A/C switch: ON	Approx. 0.36 - 3.88V

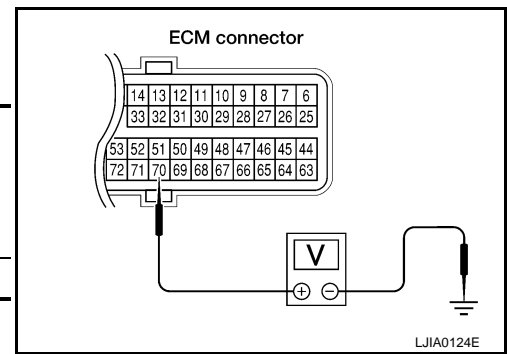

Is the inspection result normal?

- YES >> GO TO 9.  
 NO >> Refer to [EC-412, "Diagnosis Procedure"](#).

## 9. CHECK BCM INPUT (FAN ON) SIGNAL

Check FAN ON/OFF signal. Refer to [HAC-195, "CONSULT-III Function \(BCM\)"](#).

**FRONT BLOWER CONTROL : FAN ON SIG ON  
 DIAL ON**

**FRONT BLOWER CONTROL : FAN ON SIG OFF  
 DIAL OFF**

Is the inspection result normal?

- YES >> GO TO 12.  
 NO >> GO TO 10.

## 10. CHECK CIRCUIT CONTINUITY BETWEEN BCM AND FRONT AIR CONTROL

- Turn ignition switch OFF.
- Disconnect BCM connector and front air control connector.
- Check continuity between BCM harness connector M18 (A) terminal 28 and front air control harness connector M50 terminal 36.

**28 - 36 Continuity should exist.**

Is the inspection result normal?

- YES >> GO TO 11.  
 NO >> Repair harness or connector.

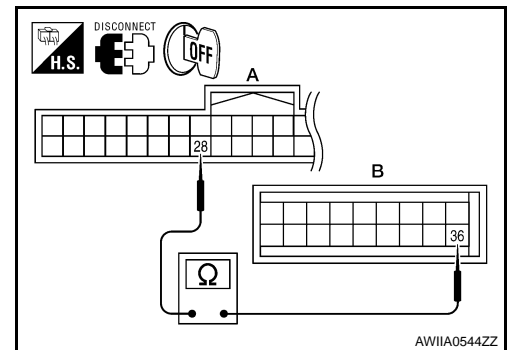

## 11. CHECK VOLTAGE FOR FRONT AIR CONTROL (FAN ON SIGNAL)

- Reconnect BCM connector and front air control connector.
- Turn ignition switch ON.
- Check voltage between front air control harness connector M50 terminal 36 and ground.

Terminals		(-)	Condition	Voltage
(+) Terminal No.				
front air control connector	Terminal No.			
M50	36	Ground	A/C switch: ON Blower motor operates	Approx. 0V
			A/C switch: OFF	Approx. 5V

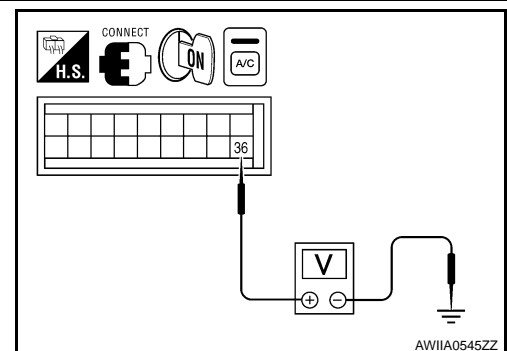

Is the inspection result normal?

- YES >> GO TO 12.  
 NO-1 >> If the voltage is approx. 5V when blower motor is ON, replace front air control. Refer to [VTL-8, "Removal and Installation"](#).



# MAGNET CLUTCH

< COMPONENT DIAGNOSIS >

[MANUAL A/C (TYPE 2)]

NO-2 >> If the voltage is approx. 0V when blower motor is OFF, replace BCM. Refer to [BCS-50. "Removal and Installation"](#).

## 12.CHECK CAN COMMUNICATION

Check CAN communication. Refer to [LAN-4. "System Description"](#).

- BCM – ECM
- ECM – IPDM E/R
- ECM – Front air control

Is the inspection result normal?

YES >> Inspection End.

NO >> Repair or replace malfunctioning part(s).

A  
B  
C  
D  
E  
F  
G  
H  
J  
K  
L  
M  
N  
O  
P

HAC

# WATER VALVE CIRCUIT

< COMPONENT DIAGNOSIS >

[MANUAL A/C (TYPE 2)]

## WATER VALVE CIRCUIT

### Description

INFOID:000000001678330

### COMPONENT DESCRIPTION

#### Water Valve

The water valve (1) cuts the flow of engine coolant to the heater core to allow for maximum cooling during A/C operation. It is controlled by the front air control.

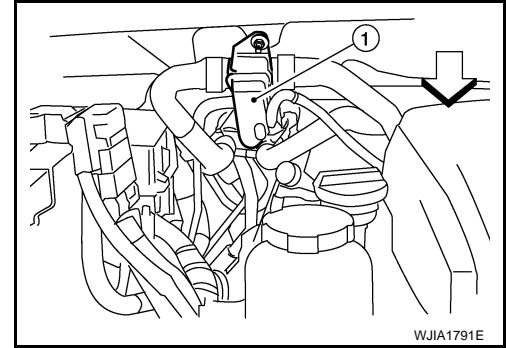

### Water Valve Diagnosis Procedure

INFOID:000000001678331

#### DIAGNOSTIC PROCEDURE FOR WATER VALVE

#### 1. CHECK WATER VALVE POWER AND GROUND CIRCUITS

1. Disconnect water valve connector F68.
2. Turn ignition switch ON.
3. Rotate temperature control dial to maximum heat.
4. Check voltage between water valve harness connector F68 terminal 1 and terminal 2 while rotating temperature control dial to maximum cold.

Connector	Terminals		Condition	Voltage (Approx.)
	(+)	(-)		
Water valve: F68	2	1	Rotate temperature control dial	Battery voltage

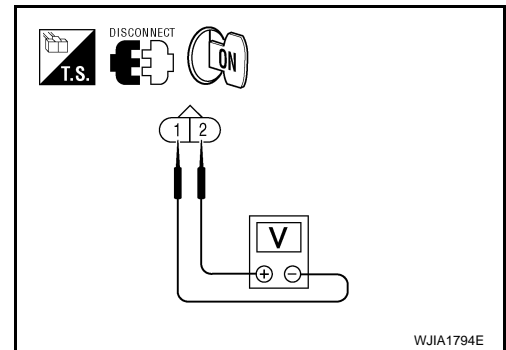

Is the inspection result normal?

- YES >> GO TO 3.  
NO >> GO TO 2.

#### 2. CHECK WATER VALVE CONTROL OUTPUT CIRCUIT

1. Turn ignition switch OFF.
2. Disconnect front air control connector M50.
3. Check continuity between water valve harness connector F68 (A) terminal 2 and front air control harness connector M50 (B) terminal 30.

**2 - 30 : Continuity should exist.**

4. Check continuity between water valve harness connector F68 terminal 2 and ground.

**2 - Ground : Continuity should not exist.**

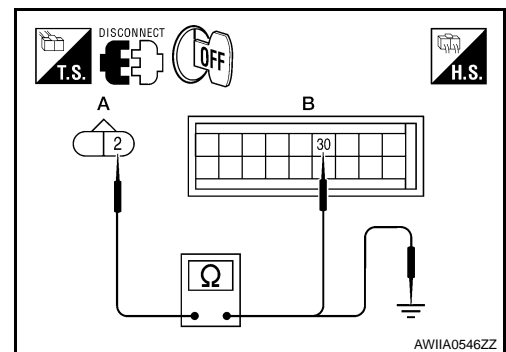

Is the inspection result normal?

- YES >> Replace front air control. Refer to [VTL-8, "Removal and Installation"](#).  
NO >> Repair harness or connector.

#### 3. CHECK WATER VALVE POWER AND GROUND CIRCUITS

# WATER VALVE CIRCUIT

[MANUAL A/C (TYPE 2)]

## < COMPONENT DIAGNOSIS >

1. Rotate temperature control dial to maximum cold.
2. Check voltage between water valve harness connector F68 terminal 1 and terminal 2 while rotating temperature control dial to maximum heat.

Connector	Terminals		Condition	Voltage (Approx.)
	(+)	(-)		
Water valve: F68	1	2	Rotate temperature control dial	Battery voltage

**Is the inspection result normal?**

- YES >> Replace the water valve.  
 NO >> GO TO 4.

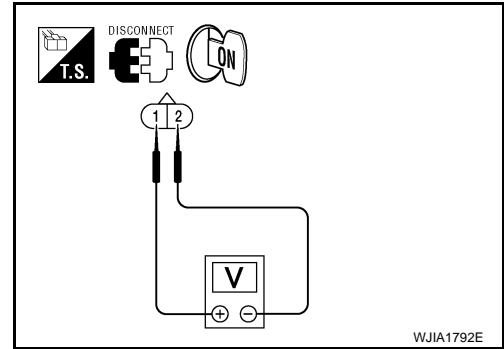

## 4. CHECK WATER VALVE CONTROL OUTPUT CIRCUIT

1. Turn ignition switch OFF.
2. Disconnect front air control connector M50.
3. Check continuity between water valve harness connector F68 (A) terminal 1 and front air control harness connector M50 (B) terminal 29.

**1 - 29 : Continuity should exist.**

4. Check continuity between water valve harness connector F68 (A) terminal 1 and ground.

**1 - Ground : Continuity should not exist.**

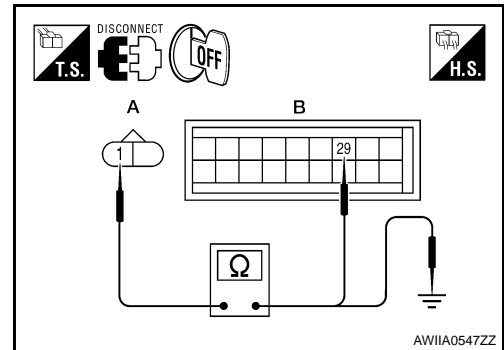

**Is the inspection result normal?**

- YES >> Replace front air control. Refer to [VTL-8, "Removal and Installation"](#).  
 NO >> Repair harness or connector.

A  
B  
C  
D  
E  
F  
G  
H  
J  
K  
L  
M  
N  
O  
P

HAC

# INTAKE SENSOR

< COMPONENT DIAGNOSIS >

[MANUAL A/C (TYPE 2)]

## INTAKE SENSOR

### System Description

INFOID:000000001678335

### COMPONENT DESCRIPTION

#### Intake Sensor

The intake sensor is located on the heater & cooling unit assembly. It converts temperature of air after it passes through the evaporator into a resistance value which is then input to the front air control.

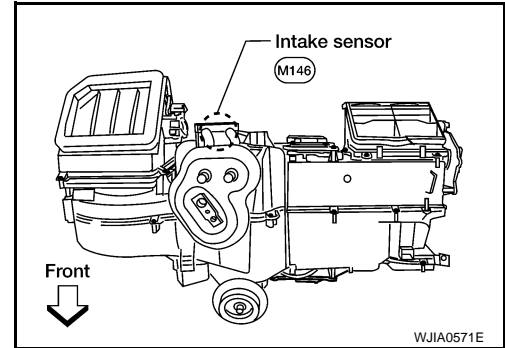

### Intake Sensor Diagnosis Procedure

INFOID:000000001678336

#### DIAGNOSTIC PROCEDURE FOR INTAKE SENSOR

SYMPTOM: Intake sensor circuit is open or shorted.

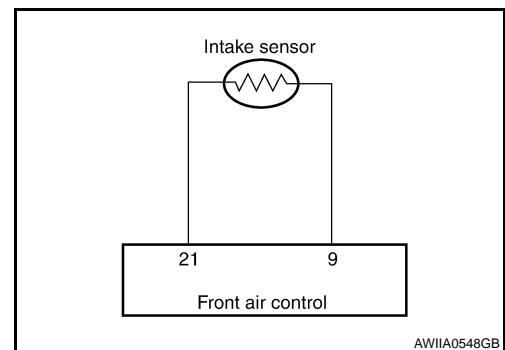

#### 1. CHECK VOLTAGE BETWEEN INTAKE SENSOR AND GROUND

1. Disconnect intake sensor connector.
2. Turn ignition switch ON.
3. Check voltage between intake sensor harness connector M146 terminal 2 and ground.

**2 - Ground : Approx. 5V**

Is the inspection result normal?

- YES >> GO TO 3.  
NO >> GO TO 4.

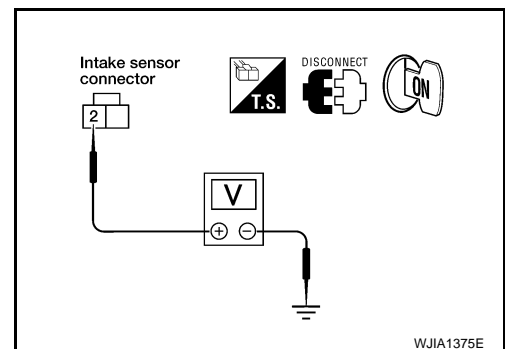

#### 2. CHECK CIRCUIT CONTINUITY BETWEEN INTAKE SENSOR AND FRONT AIR CONTROL

1. Turn ignition switch OFF.
2. Disconnect front air control connector.
3. Check continuity between intake sensor harness connector M146 (B) terminal 1 and front air control harness connector M49 (A) terminal 21.

**1 - 21 : Continuity should exist.**

Is the inspection result normal?

- YES >> GO TO 4.  
NO >> Repair harness or connector.

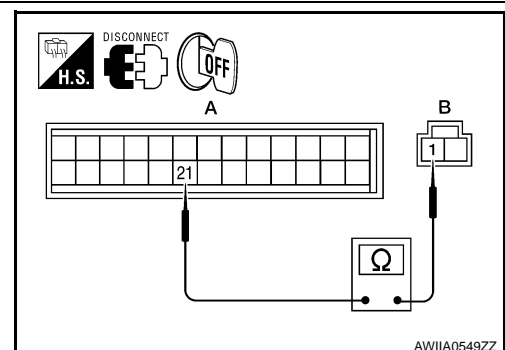

# INTAKE SENSOR

< COMPONENT DIAGNOSIS >

[MANUAL A/C (TYPE 2)]

## 3. CHECK INTAKE SENSOR

Check intake sensor. Refer to [HAC-229. "Intake Sensor Component Inspection"](#).

Is the inspection result normal?

YES >> Replace front air control. Refer to [VTL-8. "Removal and Installation"](#).

NO >> Replace intake sensor. Refer to [VTL-11. "Removal and Installation"](#).

## 4. CHECK CIRCUIT CONTINUITY BETWEEN INTAKE SENSOR AND FRONT AIR CONTROL

1. Turn ignition switch OFF.
2. Disconnect front air control connector.
3. Check continuity between intake sensor harness connector M146 (B) terminal 2 and front air control harness connector M49 (A) terminal 9.

**2 - 9 : Continuity should exist.**

4. Check continuity between intake sensor harness connector M146 terminal 6 and ground.

**2 - Ground : Continuity should not exist.**

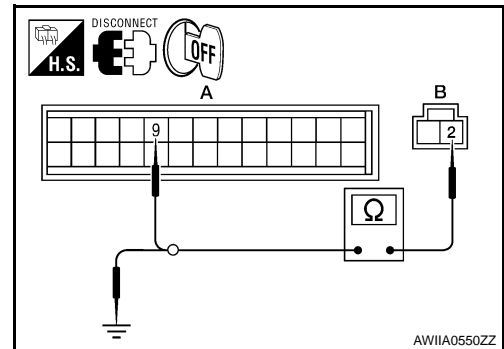

Is the inspection result normal?

YES >> Replace front air control. Refer to [VTL-8. "Removal and Installation"](#).

NO >> Repair harness or connector.

## Intake Sensor Component Inspection

INFOID:000000001678337

### COMPONENT INSPECTION

Intake Sensor

After disconnecting intake sensor connector, measure resistance between terminals 1 and 2 at sensor harness side, using the table below.

Temperature °C (°F)	Resistance kΩ
-15 (5)	209.0
-10 (14)	160.0
-5 (23)	123.0
0 (32)	95.8
5 (41)	74.9
10 (50)	58.9
15 (59)	46.7
20 (68)	37.3
25 (77)	30.0
30 (86)	24.2
35 (95)	19.7
40 (104)	16.1
45 (113)	13.2

If NG, replace intake sensor. Refer to [VTL-11. "Removal and Installation"](#).

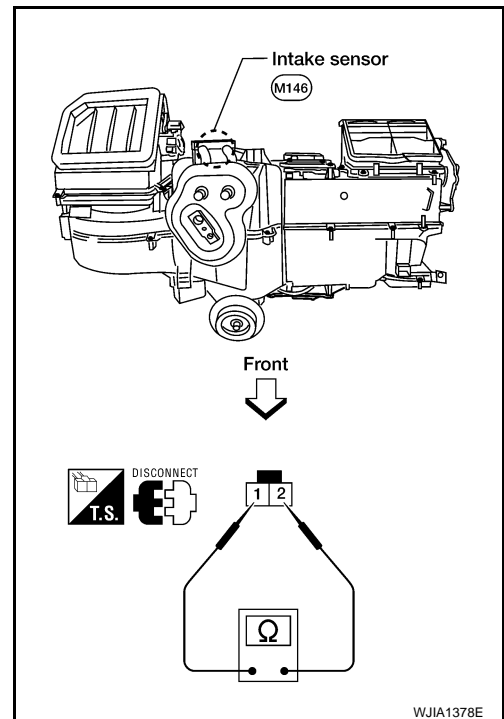

A  
B  
C  
D  
E  
F  
G  
H  
J  
K  
L  
M  
N  
O  
P

HAC

# POWER SUPPLY AND GROUND CIRCUIT FOR CONTROLLER

< COMPONENT DIAGNOSIS >

[MANUAL A/C (TYPE 2)]

## POWER SUPPLY AND GROUND CIRCUIT FOR CONTROLLER

### Component Description

INFOID:000000001678338

#### COMPONENT DESCRIPTION

##### Front Air Control

The front air control has a built-in microcomputer which processes information sent from various sensors needed for air conditioner operation. The air mix door motor, mode door motor, intake door motor, defroster door motor, blower motor and A/C compressor are then controlled.

The front air control is unitized with control mechanisms. When the various switches and temperature dials are operated, data is input to the front air control.

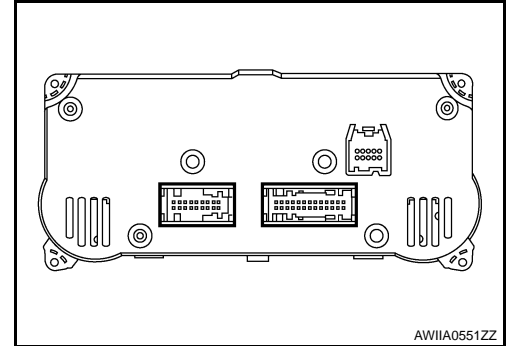

##### Potential Temperature Control (PTC)

The PTC is built into the front air control. It can be set from cold to hot or any intermediate position by rotating the temperature control dial.

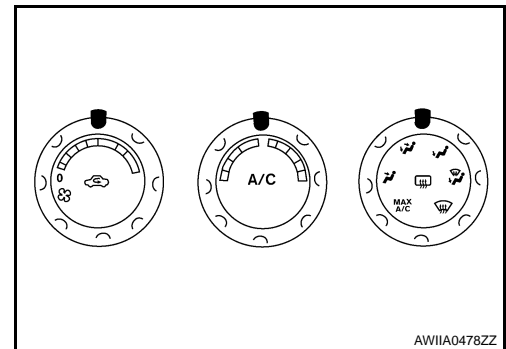

### Front Air Control Component Function Check

INFOID:000000001678339

SYMPTOM: A/C system does not come on.

#### INSPECTION FLOW

##### 1. CONFIRM SYMPTOM BY PERFORMING OPERATIONAL CHECK

1. Turn the blower control dial clockwise to low speed.
2. Press the A/C switch.
3. Confirm that the compressor clutch engages (sound or visual inspection).

Can a symptom be duplicated?

- YES >> GO TO 3.
- NO >> GO TO 2.

##### 2. PERFORM COMPLETE OPERATIONAL CHECK

Perform a complete operational check and check for any symptoms. Refer to [HAC-183, "Operational Check"](#).

Can a symptom be duplicated?

- YES >> Refer to [HAC-182, "How to Perform Trouble Diagnosis For Quick And Accurate Repair"](#).
- NO >> System OK.

##### 3. CHECK FOR SERVICE BULLETINS

Check for any service bulletins.

>> GO TO 4.

##### 4. CHECK POWER AND GROUND CIRCUIT

Check main power supply and ground circuit. Refer to [HAC-231, "Front Air Control Power and Ground Diagnosis Procedure"](#).

# POWER SUPPLY AND GROUND CIRCUIT FOR CONTROLLER

< COMPONENT DIAGNOSIS >

[MANUAL A/C (TYPE 2)]

Is the inspection result normal?

YES >> System OK.

NO >> Replace front air control. Refer to [VTL-8. "Removal and Installation"](#).

## Front Air Control Power and Ground Diagnosis Procedure

INFOID:000000001678340

### DIAGNOSTIC PROCEDURE FOR A/C SYSTEM

SYMPTOM: A/C system does not come on.

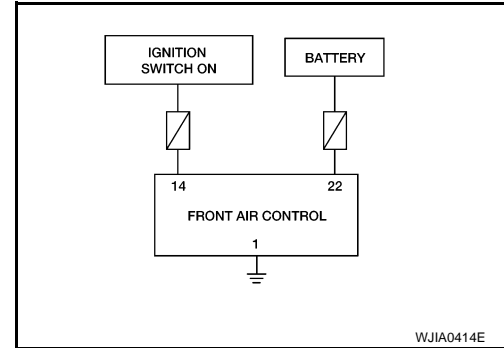

## 1. CHECK POWER SUPPLY CIRCUITS FOR FRONT AIR CONTROL

1. Disconnect front air control connectors.
2. Check voltage between front air control harness connector M49 terminals 14, 22, and ground.

Terminals		Ignition switch position			
(+)		(-)	OFF	ACC	ON
front air control connector	Terminal No.				
M49	14	Ground	Approx. 0V	Approx. 0V	Battery voltage
M49	22		Battery voltage	Battery voltage	Battery voltage

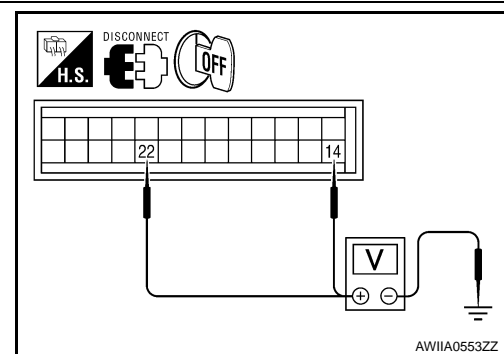

Is the inspection result normal?

YES >> GO TO 3.

NO >> Check 10A fuses [Nos. 8 and 19, located in the fuse block (J/B)]. Refer to [PG-66. "Terminal Arrangement"](#).

- If fuses are OK, check harness for open circuit. Repair or replace as necessary.
- If fuses are NG, replace fuse and check harness for short circuit. Repair or replace as necessary.

## 2. CHECK GROUND CIRCUIT FOR FRONT AIR CONTROL

1. Turn ignition switch OFF.
2. Check continuity between front air control harness connector M49 terminal 1 and ground.

**1 - Ground : Continuity should exist.**

Is the inspection result normal?

OK >> Replace front air control. Refer to [VTL-8. "Removal and Installation"](#).

NG >> Repair harness or connector.

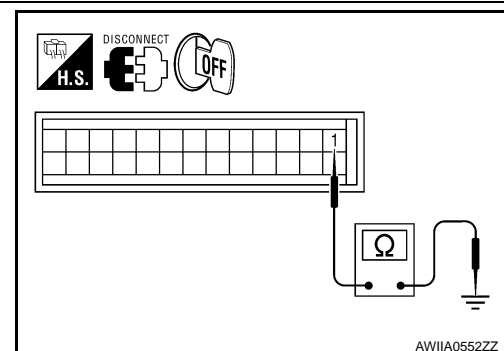

# MANUAL A/C IDENTIFICATION TABLE

< ECU DIAGNOSIS >

[MANUAL A/C (TYPE 2)]

## ECU DIAGNOSIS

### MANUAL A/C IDENTIFICATION TABLE

#### Application Table

INFOID:000000001678343

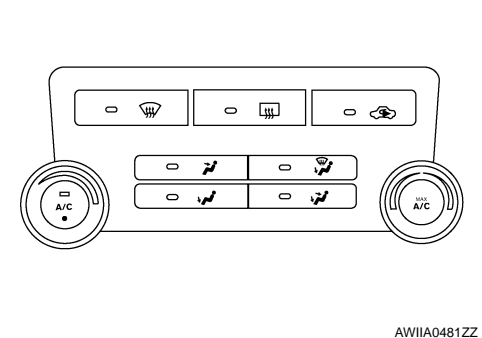
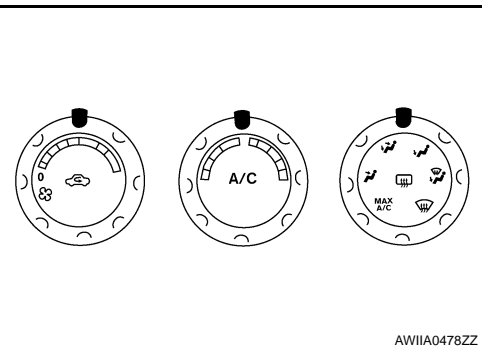
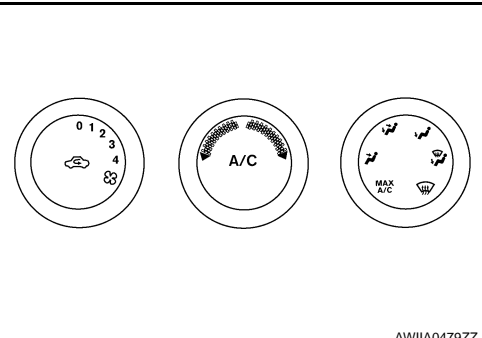
Manual A/C Type	Description	Visual Identification
Manual A/C (Type 1)	Two Control Dial System	 <p style="text-align: right;">AWIIA0481ZZ</p>
Manual A/C (Type 2)	Three Control Dial System [with variable blower control (VBC)]	 <p style="text-align: right;">AWIIA0478ZZ</p>
Manual A/C (Type 3)	Three Control Dial System [without variable blower control (VBC)]	 <p style="text-align: right;">AWIIA0479ZZ</p>



# AIR CONDITIONER CONTROL

< ECU DIAGNOSIS >

[MANUAL A/C (TYPE 2)]

## AIR CONDITIONER CONTROL

### Front Air Control Terminals Reference Values

INFOID:000000001678344

Measure voltage between each terminal and ground by following Terminals and Reference Value for front air control (1).

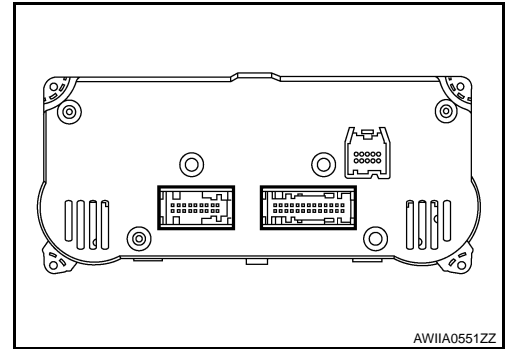

### FRONT AIR CONTROL HARNESS CONNECTOR TERMINAL LAYOUT

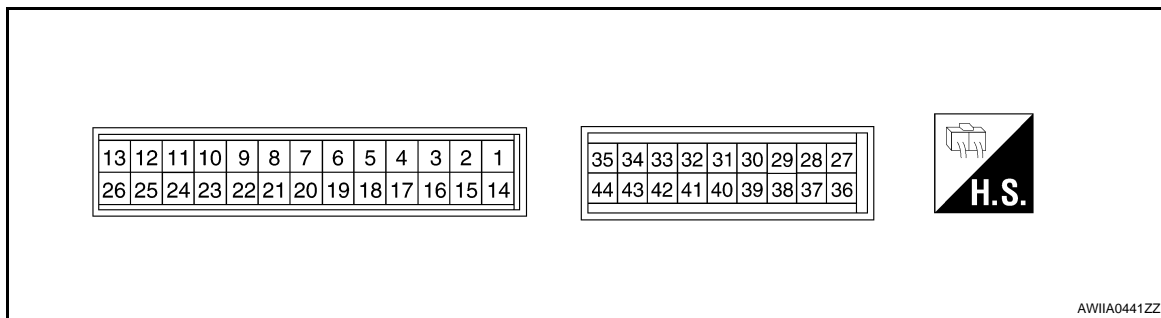

### TERMINALS AND RERERENCE VALUES FOR FRONT AIR CONTROL

Terminal No.	Wire color	Item	Ignition switch	Condition	Voltage (V) (Approx.)
1	B	Ground	-	-	0V
2	Y	V ref ACTR (5V)	ON	-	0 - 5V
3	W/G	Air mix door motor CW	ON	Clockwise rotation	Battery voltage
4	G	Air mix door motor CCW	ON	Counterclockwise rotation	Battery voltage
5	BR/W	Mode door motor CW	ON	Clockwise rotation	Battery voltage
6	P/L	Mode door motor CCW	ON	Counterclockwise rotation	Battery voltage
7	O	Intake door motor CW	ON	Clockwise rotation	Battery voltage
8	G/B	Intake door motor CCW	ON	Counterclockwise rotation	Battery voltage
9	L/B	Intake sensor	ON	-	0 - 5V
11	Y/B	Rear defrost request	ON	-	Battery voltage
12	W/R	Compressor ON signal	ON	A/C switch OFF	5V
			ON	A/C switch ON	0V
14	Y/G	Power supply for IGN	ON	-	Battery voltage
15	P	V ref ACTR (ground)	ON	-	5V
16	GR	Mode door motor feedback	ON	-	0 - 5V
18	SB	Air mix door motor feedback	ON	-	0 - 5V
19	LG	Defroster door motor CW	ON	Clockwise rotation	Battery voltage
20	P/B	Defroster door motor CCW	ON	Counterclockwise rotation	Battery voltage
21	V/R	Sensor ground	ON	-	0V
22	Y/R	Power supply for BAT	-	-	Battery voltage
23	R/L	Illumination +	ON	Park lamps ON	Battery voltage

# AIR CONDITIONER CONTROL

< ECU DIAGNOSIS >

[MANUAL A/C (TYPE 2)]

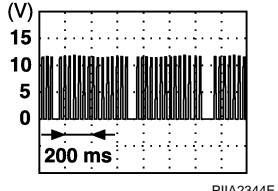
Terminal No.	Wire color	Item	Ignition switch	Condition	Voltage (V) (Approx.)
24	BR	Illumination -	-	Park lamps ON	
25	LG/B	Defroster door motor feedback	ON	-	0 - 5V
26	R/B	Front blower request	ON	Front blower motor OFF	Battery voltage
				Front blower motor ON	0V
29	Y/L	Water valve	ON	Water valve open	Battery voltage
				Water valve closed	0V
30	W/G	Water valve	ON	Water valve open	0V
				Water valve closed	Battery voltage
34	L	CAN-H	ON	-	0 - 5V
35	P	CAN-L	ON	-	0 - 5V
36	L/R	Fan ON signal	ON	Blower switch OFF	5V
			ON	Blower switch ON	0V
40	G/R	Variable blower control	ON	-	0 - 5V

# AIR CONDITIONER CONTROL

< ECU DIAGNOSIS >

[MANUAL A/C (TYPE 2)]

## Wiring Diagram

INFOID:000000001678345

### AIR CONDITIONER CONTROL - MANUAL WITH 3 CONTROL DIAL SYSTEM WITH VBC

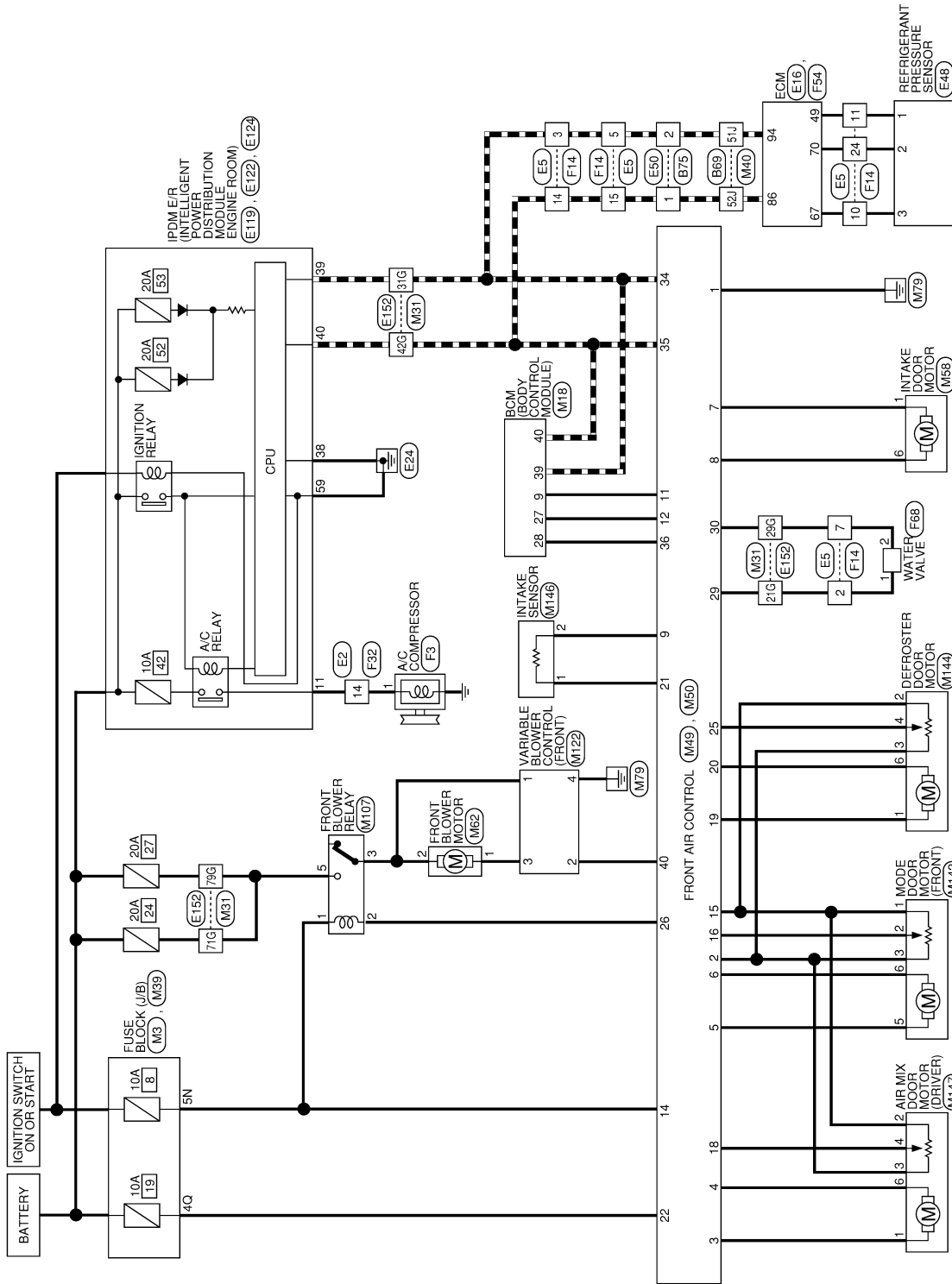

ALIWA0045GB

A  
B  
C  
D  
E  
F  
G  
H  
I  
J  
K  
L  
M  
N  
O  
P

HAC

## AIR CONDITIONER CONTROL - MANUAL WITH 3 CONTROL DIAL SYSTEM WITH VBC CONNECTORS

Connector No.	M3
Connector Name	FUSE BLOCK (J/B)
Connector Color	WHITE

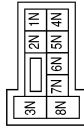

Terminal No.	Color of Wire	Signal Name
5N	Y/G	-

Connector No.	M18
Connector Name	BCM (BODY CONTROL MODULE)
Connector Color	WHITE

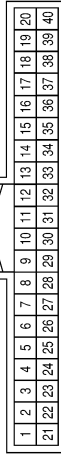

Terminal No.	Color of Wire	Signal Name
9	Y/B	RR_DEF_SW
27	W/R	AIR_CON_SW
28	L/R	BLR_FAN_SW
39	L	CAN-H
40	P	CAN-L

Connector No.	M31
Connector Name	WIRE TO WIRE
Connector Color	WHITE

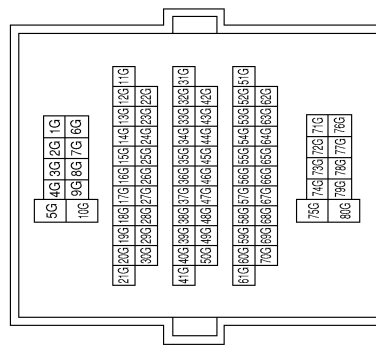

Terminal No.	Color of Wire	Signal Name
21G	Y/L	-
29G	W/G	-
31G	L	-
42G	P	-
71G	P	-
79G	P	-

Connector No.	M39
Connector Name	FUSE BLOCK (J/B)
Connector Color	WHITE



Terminal No.	Color of Wire	Signal Name
4Q	Y/R	-

ALIIA0192GB

# AIR CONDITIONER CONTROL

< ECU DIAGNOSIS >

[MANUAL A/C (TYPE 2)]

Terminal No.	Color of Wire	Signal Name
51J	L	-
52J	P	-

Connector No.	M40
Connector Name	WIRE TO WIRE
Connector Color	WHITE

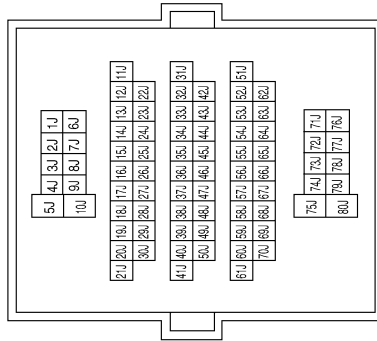

Connector No.	M49
Connector Name	A/C MANUAL AMP
Connector Color	BLACK

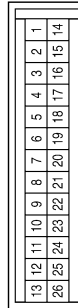

Terminal No.	Color of Wire	Signal Name
1	B	GND
2	Y	V_REF_ACTR (5V)
3	W/G	DR BLEND DR CW
4	G	DR BLEND DR CCW
5	BR/W	PANEL/FLOOR CW
6	P/L	PANEL/FLOOR CCW
7	O	RECIRC DOOR CW
8	G/B	RECIRC DOOR CCW

Terminal No.	Color of Wire	Signal Name
9	L/B	EVAP AIR TEMP_SENS
11	Y/B	RR_DEF_REQUEST
12	W/R	AC_REQUEST
14	Y/G	IGN
15	P	V_REF_RETURN
16	GR	PANEL/FLOOR_FEED_BACK
18	SB	DR_BLEAD_DR_FEED_BACK
19	LG	DEFROST CW
20	P/B	DEFROST CCW
21	V/R	SENS_RETURN
22	Y/R	VB
25	LG/B	DEFROST_FEED_BACK
26	R/B	FR_BLOWER_REQUEST

Connector No.	M50
Connector Name	A/C MANUAL AMP
Connector Color	BLUE

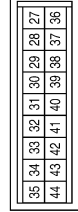

Terminal No.	Color of Wire	Signal Name
29	Y/L	WATER_VALVE_CLOSE
30	W/G	WATER_VALVE_OPEN
34	L	CAN-H
35	P	CAN-L
36	L/R	FAN_ON
40	G/R	VBC_OUTPUT_PWM

A  
B  
C  
D  
E  
F  
G  
H  
HAC  
J  
K  
L  
M  
N  
O  
P

# AIR CONDITIONER CONTROL

< ECU DIAGNOSIS >

[MANUAL A/C (TYPE 2)]

Connector No.	M58
Connector Name	INTAKE DOOR MOTOR
Connector Color	BLACK

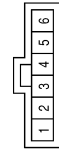

Terminal No.	Color of Wire	Signal Name
1	O	-
6	G/B	-

Connector No.	M62
Connector Name	FRONT BLOWER MOTOR
Connector Color	BLACK



Terminal No.	Color of Wire	Signal Name
1	L/W	-
2	W/L	-

Connector No.	M107
Connector Name	FRONT BLOWER RELAY
Connector Color	BLACK

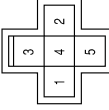

Terminal No.	Color of Wire	Signal Name
1	Y/G	-
2	R/B	-
3	W/L	-
5	GR	-

Connector No.	M122
Connector Name	VARIABLE BLOWER CONTROL (FRONT)
Connector Color	WHITE

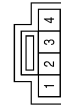

Terminal No.	Color of Wire	Signal Name
1	W/L	-
2	G/R	-
3	L/W	-
4	B/W	-

Connector No.	M142
Connector Name	MODE DOOR MOTOR (FRONT)
Connector Color	BLACK

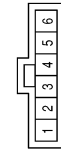

Terminal No.	Color of Wire	Signal Name
1	P	-
2	GR	-
3	Y	-
5	BR/W	-
6	P/L	-

Connector No.	M144
Connector Name	DEFROSTER DOOR MOTOR
Connector Color	BLACK

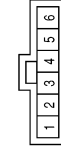

Terminal No.	Color of Wire	Signal Name
1	LG	-
2	P	-
3	Y	-
4	LG/B	-
6	P/B	-

ALIIA0194GB

# AIR CONDITIONER CONTROL

< ECU DIAGNOSIS >

[MANUAL A/C (TYPE 2)]

Connector No.	M146
Connector Name	INTAKE SENSOR
Connector Color	GRAY



Terminal No.	Color of Wire	Signal Name
1	V/R	-
2	L/B	-

Connector No.	M147
Connector Name	AIR MIX DOOR MOTOR (DRIVER)
Connector Color	BLACK



Terminal No.	Color of Wire	Signal Name
1	W/G	-
2	P	-
3	Y	-
4	SB	-
6	G	-

Connector No.	E2
Connector Name	WIRE TO WIRE
Connector Color	WHITE

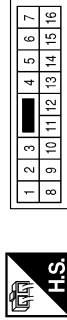

Terminal No.	Color of Wire	Signal Name
14	Y/B	-

Connector No.	E5
Connector Name	WIRE TO WIRE
Connector Color	WHITE

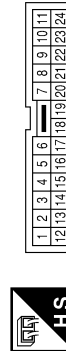

Terminal No.	Color of Wire	Signal Name
2	Y/L	-
3	L	-
5	L	-
7	W/G	-
14	P	-
15	P	-

Connector No.	E16
Connector Name	ECM
Connector Color	BLACK

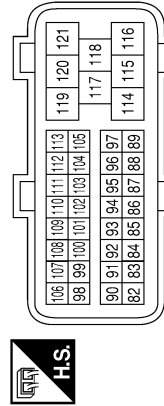

Terminal No.	Color of Wire	Signal Name
86	P	CAN-L
94	L	CAN-H

Connector No.	E50
Connector Name	WIRE TO WIRE
Connector Color	BROWN



Terminal No.	Color of Wire	Signal Name
1	P	-
2	L	-

ALIIA0195GB

A  
B  
C  
D  
E  
F  
G  
H  
HAC  
J  
K  
L  
M  
N  
O  
P

# AIR CONDITIONER CONTROL

< ECU DIAGNOSIS >

[MANUAL A/C (TYPE 2)]

Connector No.	E119
Connector Name	IPDM E/R (INTELLIGENT POWER DISTRIBUTION MODULE ENGINE ROOM)
Connector Color	WHITE

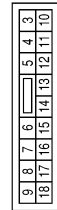

Terminal No.	Color of Wire	Signal Name
11	Y/B	AC_COMP

Connector No.	E122
Connector Name	IPDM E/R (INTELLIGENT POWER DISTRIBUTION MODULE ENGINE ROOM)
Connector Color	WHITE

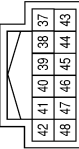

Terminal No.	Color of Wire	Signal Name
38	B	GND (SIG)
39	L	CAN-H
40	P	CAN-L

Connector No.	E124
Connector Name	IPDM E/R (INTELLIGENT POWER DISTRIBUTION MODULE ENGINE ROOM)
Connector Color	BLACK



Terminal No.	Color of Wire	Signal Name
59	B	GND (PWR)

Connector No.	E152
Connector Name	WIRE TO WIRE
Connector Color	WHITE

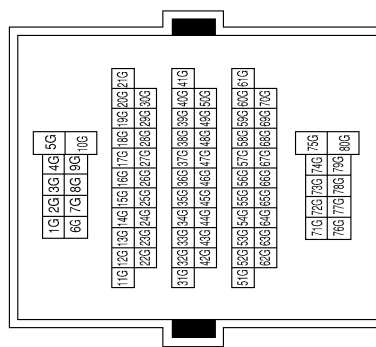

Connector No.	F3
Connector Name	A/C COMPRESSOR
Connector Color	BLACK



Terminal No.	Color of Wire	Signal Name
1	Y/B	-

ALIIA0196GB



# AIR CONDITIONER CONTROL

< ECU DIAGNOSIS >

[MANUAL A/C (TYPE 2)]

Connector No.	F68
Connector Name	WATER VALVE
Connector Color	GRAY



Terminal No.	Color of Wire	Signal Name
1	Y/L	-
2	W/G	-

Connector No.	F32
Connector Name	WIRE TO WIRE
Connector Color	WHITE

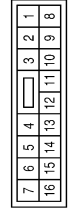

Terminal No.	Color of Wire	Signal Name
14	Y/B	-

Connector No.	F14
Connector Name	WIRE TO WIRE
Connector Color	WHITE

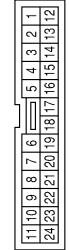

Terminal No.	Color of Wire	Signal Name
2	Y/L	-
3	L	-
5	L	-
7	W/G	-
14	P	-
15	P	-

Connector No.	B75
Connector Name	WIRE TO WIRE
Connector Color	BROWN



Terminal No.	Color of Wire	Signal Name
1	P	-
2	L	-

Terminal No.	Color of Wire	Signal Name
51J	L	-
52J	P	-

Connector No.	B69
Connector Name	WIRE TO WIRE
Connector Color	WHITE

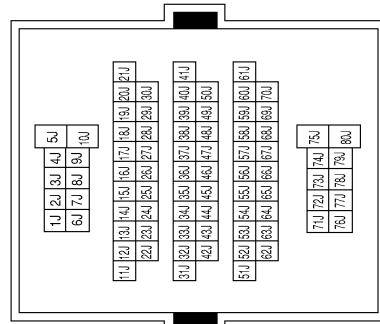

ALIIA0197GB

A  
B  
C  
D  
E  
F  
G  
H  
HAC  
J  
K  
L  
M  
N  
O  
P

# MANUAL A/C IDENTIFICATION TABLE

< SYMPTOM DIAGNOSIS >

[MANUAL A/C (TYPE 2)]

## SYMPTOM DIAGNOSIS

### MANUAL A/C IDENTIFICATION TABLE

#### Application Table

INFOID:000000001678346

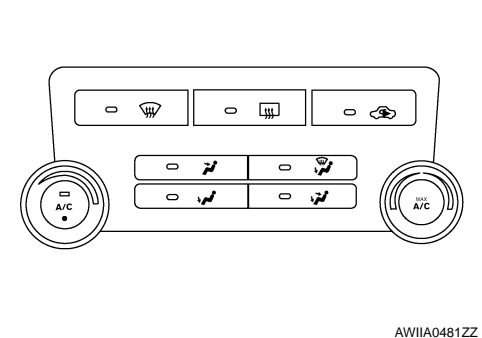
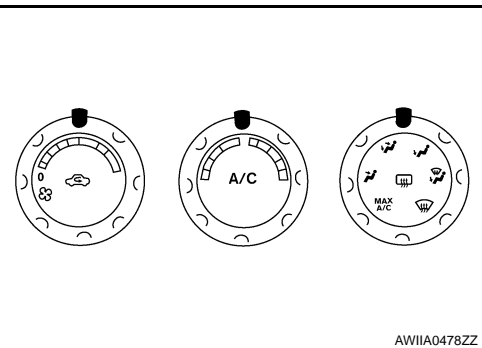
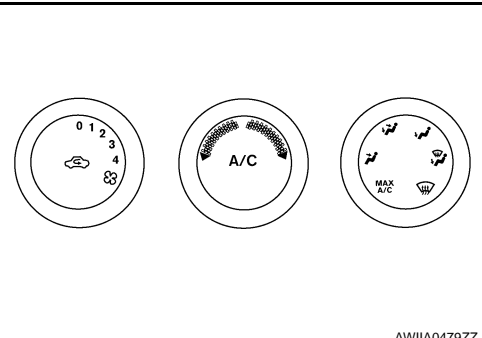
Manual A/C Type	Description	Visual Identification
Manual A/C (Type 1)	Two Control Dial System	 <p style="text-align: right;">AWIIA0481ZZ</p>
Manual A/C (Type 2)	Three Control Dial System [with variable blower control (VBC)]	 <p style="text-align: right;">AWIIA0478ZZ</p>
Manual A/C (Type 3)	Three Control Dial System [without variable blower control (VBC)]	 <p style="text-align: right;">AWIIA0479ZZ</p>

# AIR CONDITIONER CONTROL

< SYMPTOM DIAGNOSIS >

[MANUAL A/C (TYPE 2)]

## AIR CONDITIONER CONTROL

### Symptom Matrix Chart

INFOID:000000001678347

#### SYMPTOM TABLE

Symptom	Reference Page	
A/C system does not come on.	Go to Trouble Diagnosis Procedure for A/C System.	<a href="#">HAC-230</a>
Air outlet does not change.	Go to Trouble Diagnosis Procedure for Mode Door Motor.	<a href="#">HAC-197</a>
Mode door motor is malfunctioning.		
Discharge air temperature does not change.	Go to Trouble Diagnosis Procedure for Air Mix Door Motor.	<a href="#">HAC-202</a>
Air mix door motor is malfunctioning.		
Intake door does not change.	Go to Trouble Diagnosis Procedure for Intake Door Motor.	<a href="#">HAC-207</a>
Intake door motor is malfunctioning.		
Defroster door motor is malfunctioning.	Go to Trouble Diagnosis Procedure for Defroster Door Motor.	<a href="#">HAC-210</a>
Front blower motor operation is malfunctioning.	Go to Trouble Diagnosis Procedure for Front Blower Motor.	<a href="#">HAC-215</a>
Magnet clutch does not engage.	Go to Trouble Diagnosis Procedure for Magnet Clutch.	<a href="#">HAC-221</a>
Insufficient cooling	Go to Trouble Diagnosis Procedure for Insufficient Cooling.	<a href="#">HAC-244</a>
Insufficient heating	Go to Trouble Diagnosis Procedure for Insufficient Heating.	<a href="#">HAC-252</a>
Noise	Go to Trouble Diagnosis Procedure for Noise.	<a href="#">HAC-254</a>

A  
B  
C  
D  
E  
F  
G  
H  
J  
K  
L  
M  
N  
O  
P

HAC

**INSUFFICIENT COOLING****Component Function Check**

SYMPTOM: Insufficient cooling

**INSPECTION FLOW****1. CONFIRM SYMPTOM BY PERFORMING OPERATIONAL CHECK - TEMPERATURE DECREASE**

1. Rotate the blower control dial to the low speed.
2. Turn temperature control dial counterclockwise to maximum cold.
3. Check for cold air at discharge air outlets.

Can the symptom be duplicated?

- YES >> GO TO 3.  
NO >> GO TO 2.

**2. CHECK FOR ANY SYMPTOMS**Perform a complete operational check for any symptoms. Refer to [HAC-183, "Operational Check"](#).Does another symptom exist?

- YES >> Refer to [HAC-243, "Symptom Matrix Chart"](#).  
NO >> System OK.

**3. CHECK FOR SERVICE BULLETINS**

Check for any service bulletins.

&gt;&gt; GO TO 3.

**4. CHECK DRIVE BELTS**Check compressor belt tension. Refer to [EM-12, "Checking Drive Belts"](#).Is the inspection result normal?

- OK >> GO TO 5.  
NG >> Adjust or replace compressor belt. Refer to [EM-12, "Removal and Installation"](#).

**5. CHECK AIR MIX DOOR OPERATION**Check and verify air mix door mechanism for smooth operation. Refer to [HAC-202, "Air Mix Door Motor Component Function Check"](#)Does air mix door operate correctly?

- YES >> GO TO 6.  
NO >> Check air mix door motor circuit. Refer to [HAC-203, "Air Mix Door Motor Diagnosis Procedure"](#).

**6. CHECK COOLING FAN MOTOR OPERATION**Check and verify cooling fan motor for smooth operation. Refer to [EC-386, "Component Inspection"](#).Does cooling fan motor operate correctly?

- YES >> GO TO 7.  
NO >> Check cooling fan motor. Refer to [EC-386, "Diagnosis Procedure"](#).

**7. CHECK WATER VALVE OPERATION**Check and verify water valve for smooth operation. Refer to [HAC-226, "Description"](#).Does water valve operate correctly?

- YES >> GO TO 8.  
NO >> Check water valve circuit. Refer to [HAC-226, "Water Valve Diagnosis Procedure"](#).

**8. CHECK RECOVERY/RECYCLING EQUIPMENT BEFORE USAGE**

Check recovery/recycling equipment before connecting to vehicle. Verify there is no pressure in the recovery/recycling equipment by checking the gauges. If pressure exists, recover refrigerant from equipment lines.

&gt;&gt; GO TO 9.

# INSUFFICIENT COOLING

< SYMPTOM DIAGNOSIS >

[MANUAL A/C (TYPE 2)]

## 9. CHECK REFRIGERANT PURITY

1. Connect recovery/recycling equipment to vehicle.
2. Confirm refrigerant purity in supply tank using recovery/recycling and refrigerant identifier.

Is the inspection result normal?

YES >> GO TO 10.

NO >> Check contaminated refrigerant. Refer to [HAC-256, "Working with HFC-134a \(R-134a\)"](#).

## 10. CHECK FOR EVAPORATOR FREEZE UP

Start engine and run A/C. Check for evaporator freeze up.

Does evaporator freeze up?

YES >> Perform performance test diagnoses. Refer to [HAC-245, "Performance Test Diagnoses"](#).

NO >> GO TO 11.

## 11. CHECK REFRIGERANT PRESSURE

Check refrigerant pressure with manifold gauge connected. Refer to [HAC-248, "Test Reading"](#).

Is the inspection result normal?

YES >> Perform performance test diagnoses. Refer to [HAC-245, "Performance Test Diagnoses"](#).

NO >> GO TO 12.

## 12. CHECK AIR DUCTS

Check ducts for air leaks.

Is the inspection result normal?

YES >> System OK.

NO >> Repair air leaks.

Performance Test Diagnoses

INFOID:000000001678349

HAC

J

K

L

M

N

O

P

# INSUFFICIENT COOLING

< SYMPTOM DIAGNOSIS >

[MANUAL A/C (TYPE 2)]

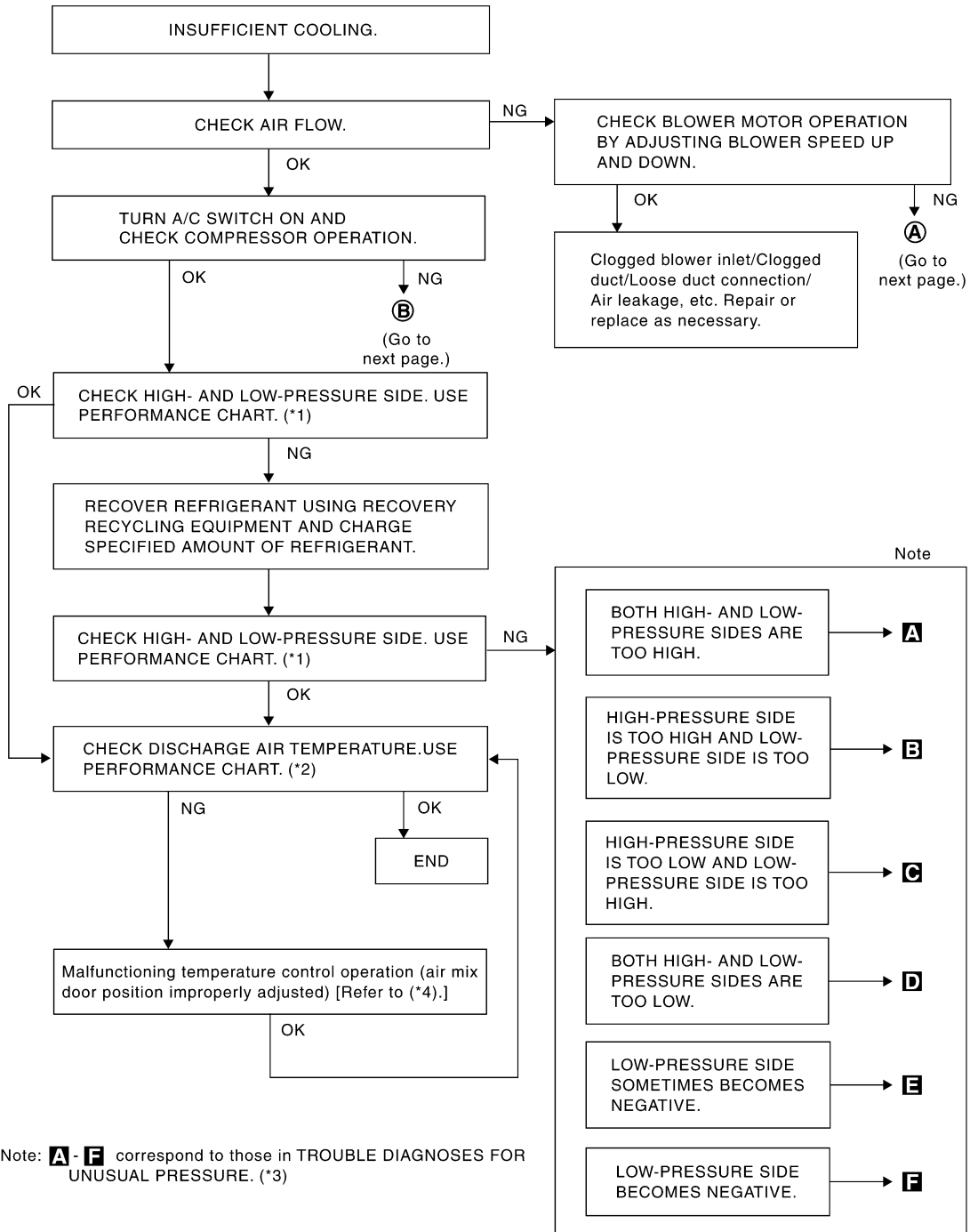

RJA1601E

\*1 [HAC-247. "Performance Chart"](#)

\*2 [HAC-248. "Test Reading"](#)

\*3 [HAC-249. "Trouble Diagnoses for Unusual Pressure"](#)

\*4 [HAC-202. "Air Mix Door Motor Component Function Check"](#)

# INSUFFICIENT COOLING

< SYMPTOM DIAGNOSIS >

[MANUAL A/C (TYPE 2)]

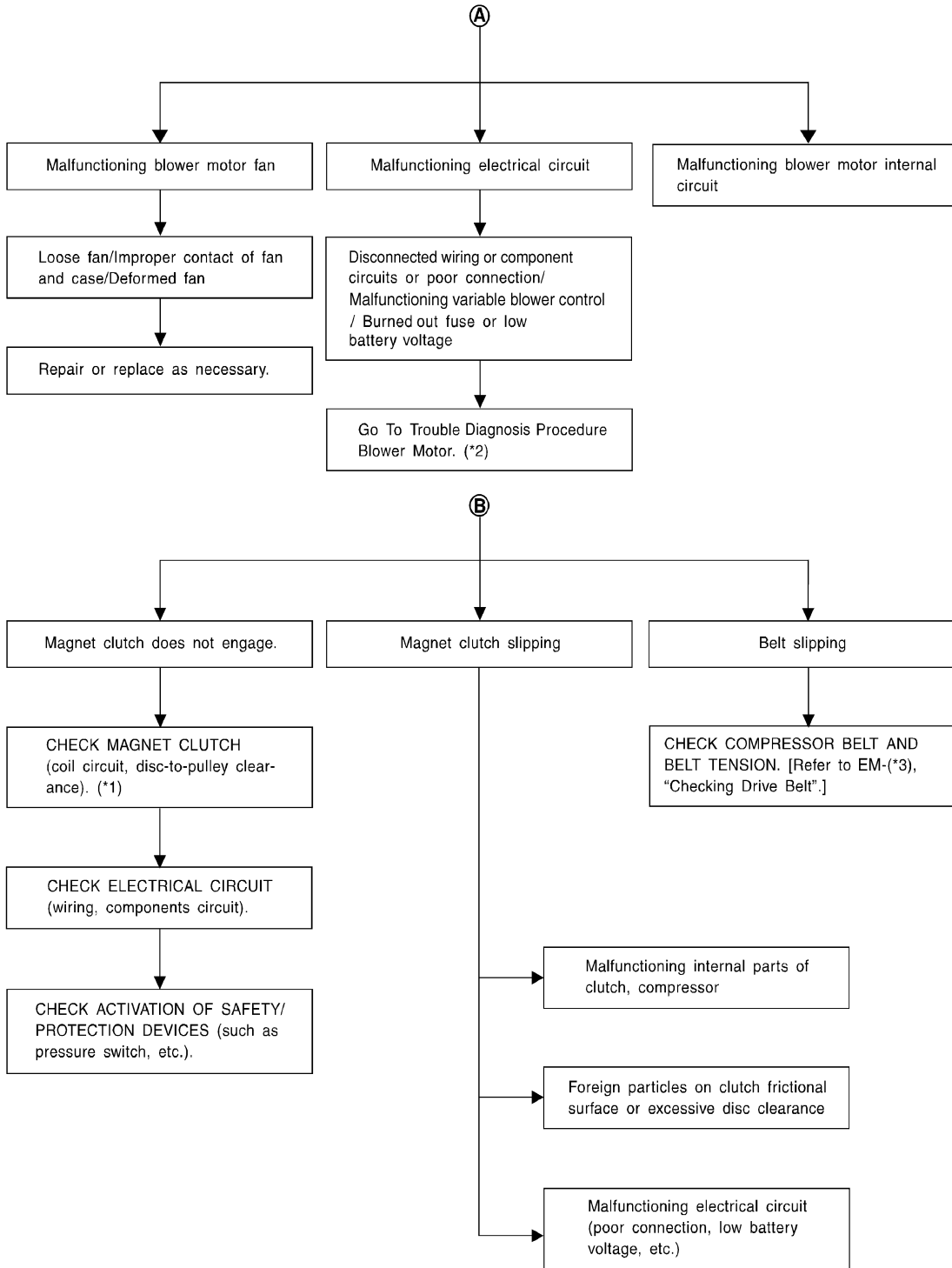

A  
B  
C  
D  
E  
F  
G  
H  
I  
J  
K  
L  
M  
N  
O  
P

HAC

WJIA1371E

\*1 [HA-34. "Removal and Installation for Compressor Clutch"](#)

\*2 [HAC-215. "Front Blower Motor Component Function Check"](#)

\*3 [EM-12. "Checking Drive Belts"](#)

## Performance Chart

INFOID:000000001678350



Test Condition

# INSUFFICIENT COOLING

< SYMPTOM DIAGNOSIS >

[MANUAL A/C (TYPE 2)]

Testing must be performed as follows:

Vehicle location	Indoors or in the shade (in a well-ventilated place)
Doors	Closed
Door window	Open
Hood	Open
TEMP.	Max. COLD
Mode control dial	 (Ventilation) set
Recirculation (REC) switch	 (Recirculation) set
 Blower speed	Max. speed set
Engine speed	Idle speed

Operate the air conditioning system for 10 minutes before taking measurements.

## Test Reading

INFOID:000000001678351

### Recirculating-to-discharge Air Temperature Table

Inside air (Recirculating air) at blower assembly inlet		Discharge air temperature at center ventilator °C (°F)
Relative humidity %	Air temperature °C (°F)	
50 - 60	20 (68)	9.9 - 13.9 (50 - 57)
	25 (77)	14.6 - 18.6 (58 - 65)
	30 (86)	16.8 - 21.8 (62 - 71)
	35 (95)	21.1 - 27.1 (70 - 81)
	40 (104)	25.3 - 31.5 (78 - 89)
60 - 70	20 (68)	11.4 - 15.2 (53 - 59)
	25 (77)	15.5 - 20.0 (60 - 68)
	30 (86)	19.9 - 25.0 (68 - 77)
	35 (95)	24.5 - 29.6 (76 - 85)
	40 (104)	28.7 - 34.9 (84 - 95)

### Ambient Air Temperature-to-operating Pressure Table

Ambient air		High-pressure (Discharge side) kPa (kg/cm <sup>2</sup> , psi)	Low-pressure (Suction side) kPa (kg/cm <sup>2</sup> , psi)
Relative humidity %	Air temperature °C (°F)		
50 - 70	20 (68)	1020 - 1250 (10.4 - 12.7, 147.9 - 181.3)	160 - 190 (1.63 - 1.94, 23.2 - 27.6)
	25 (77)	1236 - 1510 (12.6 - 15.4, 179.2 - 219)	206 - 245 (2.1 - 2.5, 29.9 - 35.6)
	30 (86)	1569 - 1,922 (16.0 - 19.6, 227.6 - 278.8)	265 - 324 (2.7 - 3.3, 38.4 - 46.9)
	35 (95)	1,697 - 2079 (17.3 - 21.2, 246.1 - 301.5)	304 - 363 (3.1 - 3.7, 44.1 - 52.6)
	40 (104)	1971 - 2403 (20.1 - 24.5, 285.9 - 348.5)	373 - 451 (3.8 - 4.6, 54.0 - 65.4)



# INSUFFICIENT COOLING

< SYMPTOM DIAGNOSIS >

[MANUAL A/C (TYPE 2)]

## Trouble Diagnoses for Unusual Pressure

INFOID:000000001678352

Whenever system's high and/or low side pressure is unusual, diagnose using a manifold gauge. The marker above the gauge scale in the following tables indicates the standard (usual) pressure range. Since the standard (usual) pressure, however, differs from vehicle to vehicle, refer to above table (Ambient air temperature-to-operating pressure table).

### Both High- and Low-pressure Sides are Too High

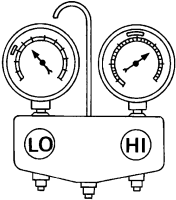
Gauge indication	Refrigerant cycle	Probable cause	Corrective action
<p>Both high- and low-pressure sides are too high.</p>  <p>AC359A</p>	<p>Pressure is reduced soon after water is splashed on condenser.</p>	<p>Excessive refrigerant charge in refrigeration cycle</p>	<p>Reduce refrigerant until specified pressure is obtained.</p>
	<p>Air suction by cooling fan is insufficient.</p>	<p>Insufficient condenser cooling performance ↓ 1. Condenser fins are clogged. 2. Improper fan rotation of cooling fan</p>	<ul style="list-style-type: none"> <li>Clean condenser.</li> <li>Check and repair cooling fan if necessary.</li> </ul>
	<ul style="list-style-type: none"> <li>Low-pressure pipe is not cold.</li> <li>When compressor is stopped high-pressure value quickly drops by approximately 196 kPa (2 kg/cm<sup>2</sup>, 28 psi). It then decreases gradually thereafter.</li> </ul>	<p>Poor heat exchange in condenser (After compressor operation stops, high-pressure decreases too slowly.) ↓ Air in refrigeration cycle</p>	<p>Evacuate and recharge system.</p>
	<p>Engine tends to overheat.</p>	<p>Engine cooling systems malfunction.</p>	<p>Check and repair engine cooling system.</p>
	<ul style="list-style-type: none"> <li>An area of the low-pressure pipe is colder than areas near the evaporator outlet.</li> <li>Plates are sometimes covered with frost.</li> </ul>	<ul style="list-style-type: none"> <li>Excessive liquid refrigerant on low-pressure side</li> <li>Excessive refrigerant discharge flow</li> <li>Expansion valve is open a little compared with the specification.</li> </ul> <p>↓ Improper expansion valve adjustment</p>	<p>Replace expansion valve.</p>

### High-pressure Side is Too High and Low-pressure Side is Too Low

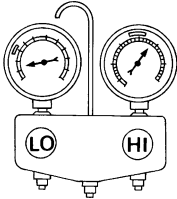
Gauge indication	Refrigerant cycle	Probable cause	Corrective action
<p>High-pressure side is too high and low-pressure side is too low.</p>  <p>AC360A</p>	<p>Upper side of condenser and high-pressure side are hot, however, liquid tank is not so hot.</p>	<p>High-pressure tube or parts located between compressor and condenser are clogged or crushed.</p>	<ul style="list-style-type: none"> <li>Check and repair or replace malfunctioning parts.</li> <li>Check oil for contamination.</li> </ul>

### High-pressure Side is Too Low and Low-pressure Side is Too High

# INSUFFICIENT COOLING

< SYMPTOM DIAGNOSIS >

[MANUAL A/C (TYPE 2)]

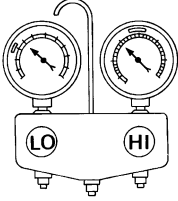
Gauge indication	Refrigerant cycle	Probable cause	Corrective action
High-pressure side is too low and low-pressure side is too high.   AC356A	High- and low-pressure sides become equal soon after compressor operation stops.	Compressor pressure operation is improper. ↓ Damaged inside compressor packings.	Replace compressor.
	No temperature difference between high- and low-pressure sides.	Compressor pressure operation is improper. ↓ Damaged inside compressor packings.	Replace compressor.

## Both High- and Low-pressure Sides are Too Low

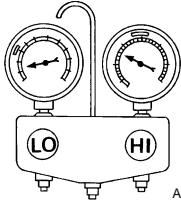
Gauge indication	Refrigerant cycle	Probable cause	Corrective action
Both high- and low-pressure sides are too low.   AC353A	<ul style="list-style-type: none"> <li>There is a big temperature difference between liquid tank outlet and inlet. Outlet temperature is extremely low.</li> <li>Liquid tank inlet and expansion valve are frosted.</li> </ul>	Liquid tank inside is slightly clogged.	<ul style="list-style-type: none"> <li>Replace liquid tank.</li> <li>Check oil for contamination.</li> </ul>
	<ul style="list-style-type: none"> <li>Temperature of expansion valve inlet is extremely low as compared with areas near liquid tank.</li> <li>Expansion valve inlet may be frosted.</li> <li>Temperature difference occurs somewhere in high-pressure side.</li> </ul>	High-pressure pipe located between liquid tank and expansion valve is clogged.	<ul style="list-style-type: none"> <li>Check and repair malfunctioning parts.</li> <li>Check oil for contamination.</li> </ul>
	Expansion valve and liquid tank are warm or only cool when touched.	Low refrigerant charge. ↓ Leaking fittings or components.	Check refrigerant system for leaks. Refer to <a href="#">HA-23, "Checking of Refrigerant Leaks"</a> .
	There is a big temperature difference between expansion valve inlet and outlet while the valve itself is frosted.	Expansion valve closes a little compared with the specification. ↓ 1. Improper expansion valve adjustment. 2. Malfunctioning expansion valve. 3. Outlet and inlet may be clogged.	<ul style="list-style-type: none"> <li>Remove foreign particles by using compressed air.</li> <li>Check oil for contamination.</li> </ul>
	An area of the low-pressure pipe is colder than areas near the evaporator outlet.	Low-pressure pipe is clogged or crushed.	<ul style="list-style-type: none"> <li>Check and repair malfunctioning parts.</li> <li>Check oil for contamination.</li> </ul>
	Air flow volume is too low.	Evaporator is frozen.	<ul style="list-style-type: none"> <li>Check intake sensor circuit. Refer to <a href="#">HAC-228, "Intake Sensor Diagnosis Procedure"</a>.</li> <li>Repair evaporator fins.</li> <li>Replace evaporator.</li> <li>Refer to <a href="#">HAC-215, "Front Blower Motor Component Function Check"</a>.</li> </ul>

## Low-pressure Side Sometimes Becomes Negative

# INSUFFICIENT COOLING

< SYMPTOM DIAGNOSIS >

[MANUAL A/C (TYPE 2)]

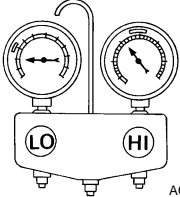
Gauge indication	Refrigerant cycle	Probable cause	Corrective action
<p>Low-pressure side sometimes becomes negative.</p>  <p style="text-align: right; font-size: small;">AC354A</p>	<ul style="list-style-type: none"> <li>Air conditioning system does not function and does not cyclically cool the compartment air.</li> <li>The system constantly functions for a certain period of time after compressor is stopped and restarted.</li> </ul>	<p>Refrigerant does not discharge cyclically.</p> <p>↓</p> <p>Moisture is frozen at expansion valve outlet and inlet.</p> <p>↓</p> <p>Water is mixed with refrigerant.</p>	<ul style="list-style-type: none"> <li>Drain water from refrigerant or replace refrigerant.</li> <li>Replace liquid tank.</li> </ul>

## Low-pressure Side Becomes Negative

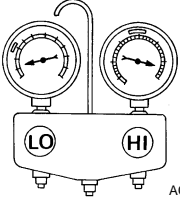
Gauge indication	Refrigerant cycle	Probable cause	Corrective action
<p>Low-pressure side becomes negative.</p>  <p style="text-align: right; font-size: small;">AC362A</p>	<p>Liquid tank or front/rear side of expansion valve's pipe is frosted or dewed.</p>	<p>High-pressure side is closed and refrigerant does not flow.</p> <p>↓</p> <p>Expansion valve or liquid tank is frosted.</p>	<p>Leave the system at rest until no frost is present. Start it again to check whether or not the malfunction is caused by water or foreign particles.</p> <ul style="list-style-type: none"> <li>If water is the cause, initially cooling is okay. Then the water freezes causing a blockage. Drain water from refrigerant or replace refrigerant.</li> <li>If due to foreign particles, remove expansion valve and remove the particles with dry and compressed air (not shop air).</li> <li>If either of the above methods cannot correct the malfunction, replace expansion valve.</li> <li>Replace liquid tank.</li> <li>Check oil for contamination.</li> </ul>

A  
B  
C  
D  
E  
F  
G  
H  
HAC  
J  
K  
L  
M  
N  
O  
P

**INSUFFICIENT HEATING****Component Function Check**

INFOID:000000001678353

SYMPTOM: Insufficient heating

**INSPECTION FLOW****1. CONFIRM SYMPTOM BY PERFORMING OPERATIONAL CHECK - TEMPERATURE INCREASE**

1. Turn the blower control dial to low speed.
2. Turn the temperature control dial clockwise to maximum heat
3. Check for hot air at discharge air outlets.

Can this symptom be duplicated?

YES &gt;&gt; GO TO 2.

NO >> Perform complete system operational check. Refer to [HAC-183, "Operational Check"](#).**2. CHECK FOR SERVICE BULLETINS**

Check for any service bulletins.

&gt;&gt; GO TO 3.

**3. CHECK ENGINE COOLING SYSTEM**

1. Check for proper engine coolant level. Refer to [CO-10, "Inspection"](#).
2. Check hoses for leaks or kinks.
3. Check radiator cap. Refer to [CO-10, "Inspection"](#).
4. Check for air in cooling system.

&gt;&gt; GO TO 4.

**4. CHECK AIR MIX DOOR OPERATION**

Check the operation of the air mix door.

Is the inspection result normal?

YES &gt;&gt; GO TO 5.

NO >> Check the air mix door motor circuit. Refer to [HAC-202, "Air Mix Door Motor Component Function Check"](#).**5. CHECK AIR DUCTS**

Check for disconnected or leaking air ducts.

Is the inspection result normal?

YES &gt;&gt; GO TO 6.

NO &gt;&gt; Repair all disconnected or leaking air ducts.

**6. CHECK HEATER HOSE TEMPERATURES**

1. Start engine and warm it up to normal operating temperature.
2. Touch both the inlet and outlet heater hoses.

Is the inspection result normal?

YES &gt;&gt; Hot inlet hose and a warm outlet hose: GO TO 7.

NO >> • Inlet hose cold: GO TO 10.  
• Both hoses warm: GO TO 8.**7. CHECK ENGINE COOLANT SYSTEM**Check engine control temperature sensor. Refer to [EC-126, "Component Inspection"](#).Is the inspection result normal?

YES &gt;&gt; System OK.

NO &gt;&gt; Repair or replace as necessary. Retest.

**8. CHECK HEATER HOSES**

Check heater hoses for proper installation.

# INSUFFICIENT HEATING

< SYMPTOM DIAGNOSIS >

[MANUAL A/C (TYPE 2)]

Is the inspection result normal?

YES >> System OK.

NO >> 1. Back flush heater core.

2. Drain the water from the system.

3. Refill system with new engine coolant. Refer to [CO-11, "Changing Engine Coolant"](#).

4. GO TO 10 to retest.

## 9. CHECK HEATER HOSE TEMPERATURES

1. Start engine and warm it up to normal operating temperature.

2. Touch both the inlet and outlet heater hoses.

Is the inspection result normal?

YES >> System OK.

NO >> Replace heater core. Refer to [VTL-15, "Removal and Installation"](#).

## 10. CHECK WATER VALVE

Check the operation of the water valve. Refer to [HAC-226, "Water Valve Diagnosis Procedure"](#).

Is the inspection result normal?

YES >> System OK.

NO >> Replace water valve.

A  
B  
C  
D  
E  
F  
G  
H  
J  
K  
L  
M  
N  
O  
P

HAC

NOISE

Component Function Check

INFOID:000000001678354

SYMPTOM: Noise

INSPECTION FLOW

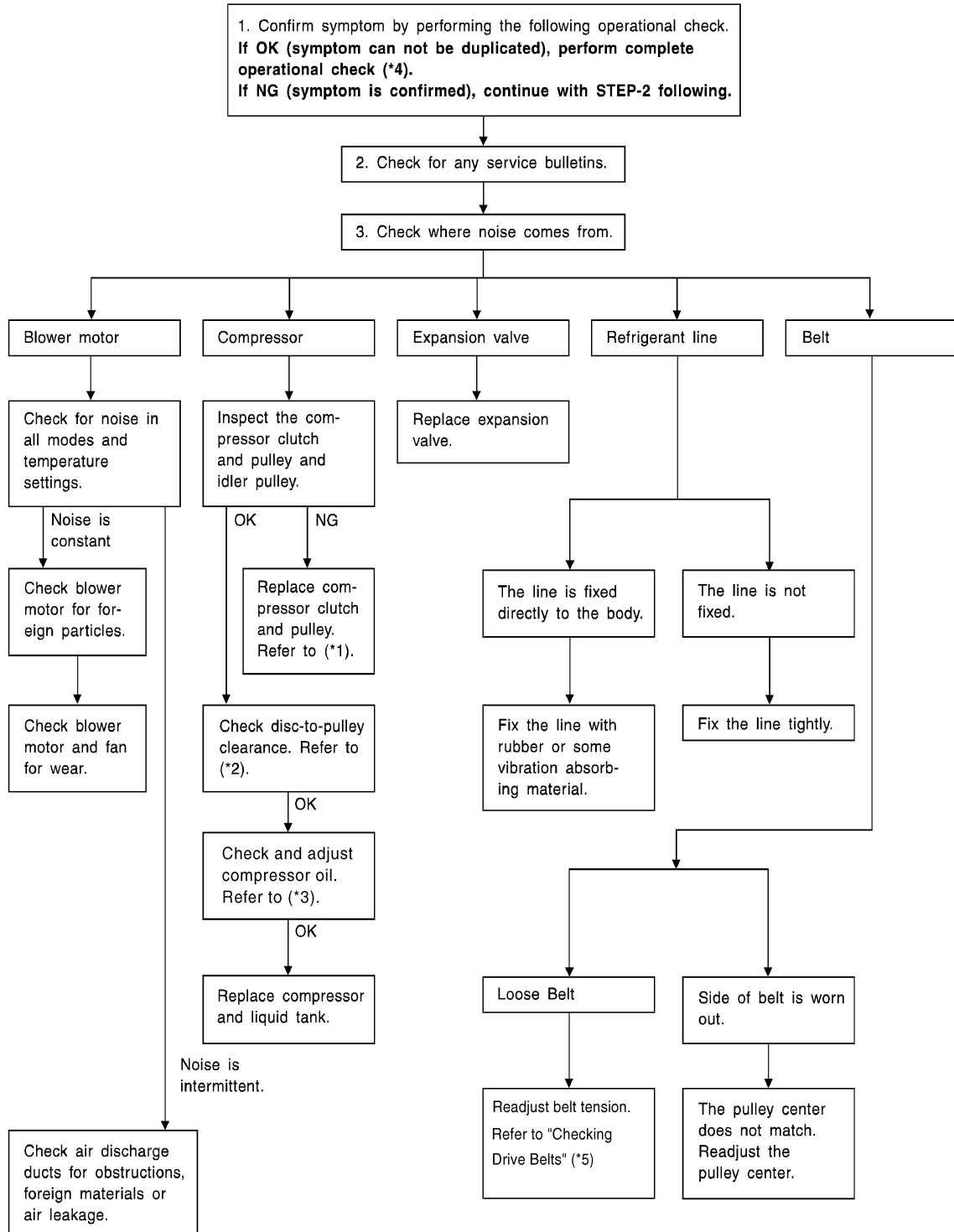

WJIA1972E

# NOISE

< SYMPTOM DIAGNOSIS >

[MANUAL A/C (TYPE 2)]

- |    |   |    |   |    |  |   |
|----|---|----|---|----|--|---|
| *1 | <a href="#">HA-34. "Removal and Installation for Compressor Clutch"</a> | *2 | <a href="#">HA-34. "Removal and Installation for Compressor Clutch"</a> | *3 | <a href="#">HA-20. "Maintenance of Oil Quantity in Compressor"</a> | A |
| *4 | <a href="#">HAC-183. "Operational Check"</a>                            | *5 | <a href="#">EM-12. "Checking Drive Belts"</a>                           |    |  | B |

B

C

D

E

F

G

H

HAC

J

K

L

M

N

O

P

## PRECAUTION

### PRECAUTIONS

#### Supplemental Restraint System (SRS) "AIR BAG" and "SEAT BELT PRE-TENSIONER"

INFOID:000000001678356

The Supplemental Restraint System such as "AIR BAG" and "SEAT BELT PRE-TENSIONER", used along with a front seat belt, helps to reduce the risk or severity of injury to the driver and front passenger for certain types of collision. This system includes seat belt switch inputs and dual stage front air bag modules. The SRS system uses the seat belt switches to determine the front air bag deployment, and may only deploy one front air bag, depending on the severity of a collision and whether the front occupants are belted or unbelted. Information necessary to service the system safely is included in the SR and SB section of this Service Manual.

**WARNING:**

- To avoid rendering the SRS inoperative, which could increase the risk of personal injury or death in the event of a collision which would result in air bag inflation, all maintenance must be performed by an authorized NISSAN/INFINITI dealer.
- Improper maintenance, including incorrect removal and installation of the SRS, can lead to personal injury caused by unintentional activation of the system. For removal of Spiral Cable and Air Bag Module, see the SR section.
- Do not use electrical test equipment on any circuit related to the SRS unless instructed to in this Service Manual. SRS wiring harnesses can be identified by yellow and/or orange harnesses or harness connectors.

#### Working with HFC-134a (R-134a)

INFOID:000000001678357

**WARNING:**

- CFC-12 (R-12) refrigerant and HFC-134a (R-134a) refrigerant are not compatible. If the refrigerants are mixed compressor failure is likely to occur. Refer to [HA-4, "Contaminated Refrigerant"](#). To determine the purity of HFC-134a (R-134a) in the vehicle and recovery tank, use Refrigerant Recovery/Recycling Recharging equipment and Refrigerant Identifier.
- Use only specified oil for the HFC-134a (R-134a) A/C system and HFC-134a (R-134a) components. If oil other than that specified is used, compressor failure is likely to occur.
- The specified HFC-134a (R-134a) oil rapidly absorbs moisture from the atmosphere. The following handling precautions must be observed:
  - When removing refrigerant components from a vehicle, immediately cap (seal) the component to minimize the entry of moisture from the atmosphere.
  - When installing refrigerant components to a vehicle, do not remove the caps (unseal) until just before connecting the components. Connect all refrigerant loop components as quickly as possible to minimize the entry of moisture into system.
  - Only use the specified oil from a sealed container. Immediately reseal containers of oil. Without proper sealing, oil will become moisture saturated and should not be used.
  - Avoid breathing A/C refrigerant and oil vapor or mist. Exposure may irritate eyes, nose and throat. Remove HFC-134a (R-134a) from the A/C system using certified service equipment meeting requirements of SAE J2210 [HFC-134a (R-134a) recycling equipment], or J2209 [HFC-134a (R-134a) recycling equipment], If accidental system discharge occurs, ventilate work area before resuming service. Additional health and safety information may be obtained from refrigerant and oil manufacturers.
  - Do not allow A/C oil to come in contact with styrofoam parts. Damage may result.

#### CONTAMINATED REFRIGERANT

If a refrigerant other than pure HFC-134a (R-134a) is identified in a vehicle, your options are:

- Explain to the customer that environmental regulations prohibit the release of contaminated refrigerant into the atmosphere.
- Explain that recovery of the contaminated refrigerant could damage your service equipment and refrigerant supply.
- Suggest the customer return the vehicle to the location of previous service where the contamination may have occurred.
- If you choose to perform the repair, recover the refrigerant using only **dedicated equipment and containers**. Do not recover contaminated refrigerant into your existing service equipment. If your facility does



# PRECAUTIONS

[MANUAL A/C (TYPE 2)]

## < PRECAUTION >

- not have dedicated recovery equipment, you may contact a local refrigerant product retailer for available service. This refrigerant must be disposed of in accordance with all federal and local regulations. In addition, replacement of all refrigerant system components on the vehicle is recommended.
- If the vehicle is within the warranty period, the air conditioner warranty is void. Please contact NISSAN Customer Affairs for further assistance.

## Precaution for Service Equipment

INFOID:000000001678358

### MANIFOLD GAUGE SET

Be certain that the gauge face indicates R-134a or 134a. Make sure the gauge set has 1/2"-16 ACME threaded connections for service hoses. Confirm the set has been used only with refrigerant HFC-134a (R-134a) along with specified oil.

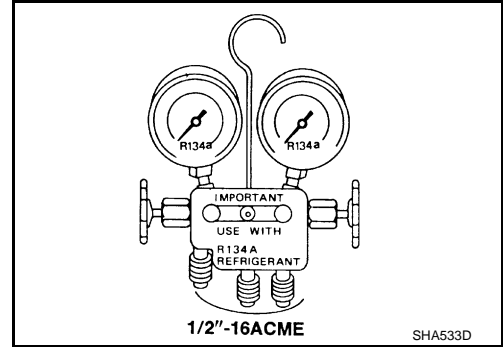

### SERVICE HOSES

Be certain that the service hoses display the markings described (colored hose with black stripe). All hoses must include positive shut-off devices (either manual or automatic) near the end of the hoses opposite the manifold gauge.

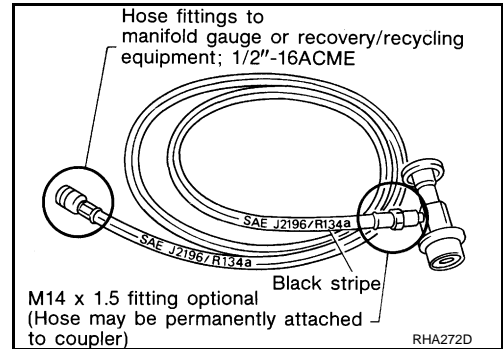

### SERVICE COUPLERS

Never attempt to connect HFC-134a (R-134a) service couplers to a CFC-12 (R-12) A/C system. The HFC-134a (R-134a) couplers will not properly connect to the CFC-12 (R-12) system. However, if an improper connection is attempted, discharging and contamination may occur.

Shut-off valve rotation	A/C service valve
Clockwise	Open
Counterclockwise	Close

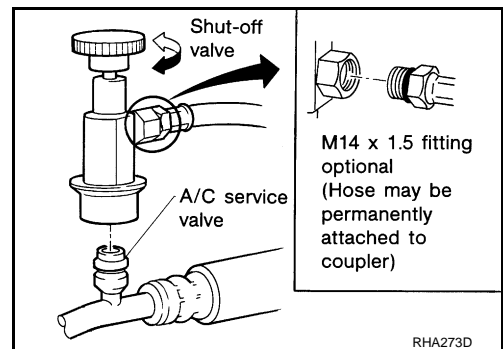

# MANUAL A/C IDENTIFICATION TABLE

< BASIC INSPECTION >

[MANUAL A/C (TYPE 3)]

## BASIC INSPECTION

### MANUAL A/C IDENTIFICATION TABLE

#### Application Table

INFOID:000000001680511

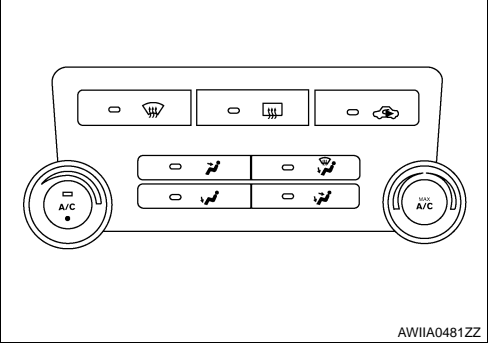
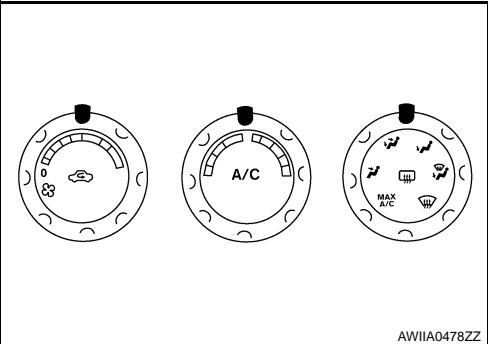
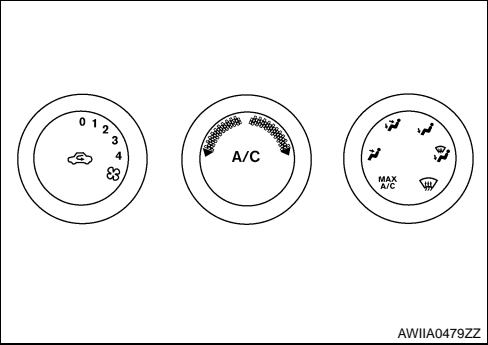
Manual A/C Type	Description	Visual Identification
Manual A/C (Type 1)	Two Control Dial System	 <p style="text-align: right; font-size: small;">AWIIA0481ZZ</p>
Manual A/C (Type 2)	Three Control Dial System [with variable blower control (VBC)]	 <p style="text-align: right; font-size: small;">AWIIA0478ZZ</p>
Manual A/C (Type 3)	Three Control Dial System [without variable blower control (VBC)]	 <p style="text-align: right; font-size: small;">AWIIA0479ZZ</p>

## DIAGNOSIS AND REPAIR WORKFLOW

How to Perform Trouble Diagnosis For Quick And Accurate Repair

INFOID:000000001680512

### WORK FLOW

#### 1. LISTEN TO CUSTOMER COMPLAINT

Listen to customer complaint. Get detailed information about the conditions and environment when the symptom occurs.

>> GO TO 2

#### 2. CHECK FOR SERVICE BULLETINS

Check for any service bulletins.

>> GO TO 3.

#### 3. VERIFY THE SYMPTOM WITH OPERATIONAL CHECK

Verify the symptom with operational check. Refer to [HAC-183, "Operational Check"](#).

>> GO TO 4

#### 4. GO TO APPROPRIATE TROUBLE DIAGNOSIS

Go to appropriate trouble diagnosis. Refer to [HAC-322, "Symptom Matrix Chart"](#).

>> If equipped with NAVI, GO TO 5.

>> If equipped without NAVI, GO TO 6.

#### 5. PERFORM THE FRONT AIR CONTROL SELF-DIAGNOSIS

Perform front air control self-diagnosis. Refer to [HAC-21, "Front Air Control Self-Diagnosis"](#).

>> If any diagnostic trouble codes set. Refer to [HAC-21, "Front Air Control Self-Diagnosis Code Chart"](#).

>> Confirm the repair by performing operational check. Refer to [HAC-7, "Operational Check"](#).

#### 6. REPAIR OR REPLACE

Repair or replace the specific parts.

>> GO TO 6

#### 7. FINAL CHECK

Final check.

Is the inspection result normal?

YES >> CHECK OUT

NO >> GO TO 4

A  
B  
C  
D  
E  
F  
G  
H  
HAC  
J  
K  
L  
M  
N  
O  
P

## INSPECTION AND ADJUSTMENT

## Operational Check

INFOID:000000001680513

The purpose of the operational check is to confirm that the system operates properly.

**Conditions : Engine running and at normal operating temperature**

## CHECKING BLOWER

1. Rotate the blower control dial clockwise once, blower should operate on low speed.
2. Rotate the blower control dial again, and continue checking blower speed until all speeds are checked.
3. Leave blower on maximum speed.

If NG, go to trouble diagnosis procedure for [HAC-293. "Front Blower Motor Diagnosis Procedure"](#).

If OK, continue with next check.

## CHECKING DISCHARGE AIR

1. Rotate MODE control dial to each position and the DEF  mode.
2. Confirm that discharge air comes out according to the air distribution table. Refer to [HAC-268. "Discharge Air Flow"](#)

Mode door position is checked in the next step.



If NG, go to trouble diagnosis procedure for [HAC-275. "Mode Door Motor Diagnosis Procedure"](#).

If OK, continue the check.

**NOTE:**

Confirm that the compressor clutch is engaged (sound or visual inspection) and intake door position is at fresh when the DEF or D/F is selected.





CHECKING RECIRCULATION (,  ONLY)

1. Press recirculation () switch one time. Recirculation indicator should illuminate.
2. Press recirculation () switch one more time. Recirculation indicator should go off.
3. Listen for intake door position change (blower sound should change slightly).

If NG, go to trouble diagnosis procedure for [HAC-285. "Intake Door Motor Diagnosis Procedure"](#).

If OK, continue the check.

**NOTE:**

Confirm that the compressor clutch is engaged (sound or visual inspection) and intake door position is at fresh when the DEF or D/F is selected. REC () is not allowed in DEF () D/F () or FOOT ()

## CHECKING TEMPERATURE DECREASE

1. Rotate temperature control dial counterclockwise until maximum cold.
2. Check for cold air at appropriate discharge air outlets.

If NG, listen for sound of air mix door motor operation. If OK, go to trouble diagnosis procedure for [HAC-323. "Component Function Check"](#). If air mix door motor appears to be malfunctioning, go to [HAC-279. "Air Mix Door Motor Component Function Check"](#).

If OK, continue the check.

## CHECKING TEMPERATURE INCREASE

1. Rotate temperature control dial clockwise until maximum hot.
2. Check for hot air at appropriate discharge air outlets.

If NG, listen for sound of air mix door motor operation. If OK, go to trouble diagnosis procedure for [HAC-331. "Component Function Check"](#). If air mix door motor appears to be malfunctioning, go to [HAC-279. "Air Mix Door Motor Component Function Check"](#).

If OK, continue with next check.

## CHECK A/C SWITCH

1. Press A/C switch.
  - Confirm that the compressor clutch engages (sound or visual inspection).

**NOTE:**

If current mode setting is DEF or D/F, compressor clutch will already be engaged and cannot be turned off.

# INSPECTION AND ADJUSTMENT

< BASIC INSPECTION >

[MANUAL A/C (TYPE 3)]

If NG, go to trouble diagnosis procedure for [HAC-299. "Magnet Clutch Diagnosis Procedure"](#).  
If all operational checks are OK (symptom cannot be duplicated), go to [HAC-259. "How to Perform Trouble Diagnosis For Quick And Accurate Repair"](#) and perform tests as outlined. If symptom appears, refer to [HAC-322. "Symptom Matrix Chart"](#) and perform applicable trouble diagnosis procedures.

- A
- B
- C
- D
- E
- F
- G
- H
- HAC
- J
- K
- L
- M
- N
- O
- P

# MANUAL A/C IDENTIFICATION TABLE

< FUNCTION DIAGNOSIS >

[MANUAL A/C (TYPE 3)]

## FUNCTION DIAGNOSIS

### MANUAL A/C IDENTIFICATION TABLE

#### Application Table

INFOID:000000001680514

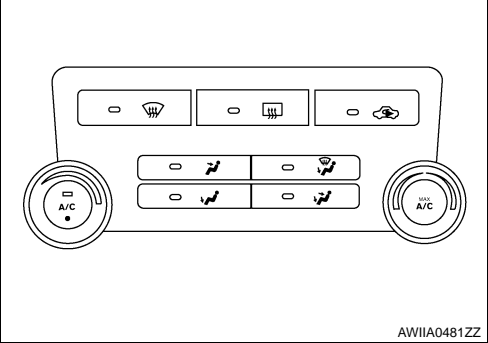
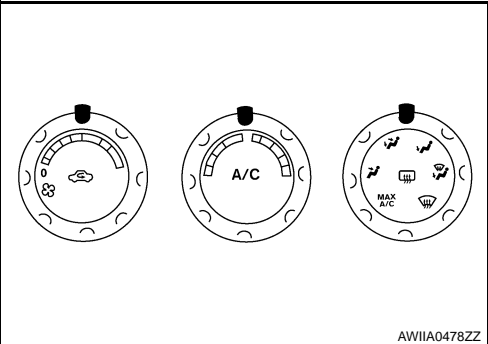
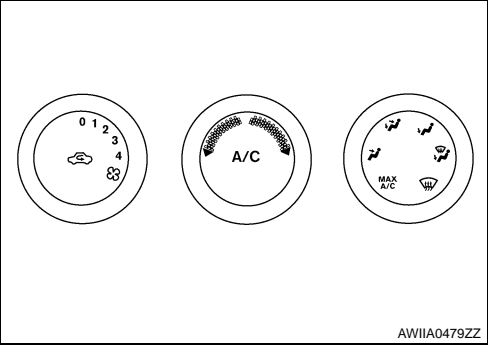
Manual A/C Type	Description	Visual Identification
Manual A/C (Type 1)	Two Control Dial System	 <p style="text-align: right;">AWIIA0481ZZ</p>
Manual A/C (Type 2)	Three Control Dial System [with variable blower control (VBC)]	 <p style="text-align: right;">AWIIA0478ZZ</p>
Manual A/C (Type 3)	Three Control Dial System [without variable blower control (VBC)]	 <p style="text-align: right;">AWIIA0479ZZ</p>

FUNCTION INFORMATION

Component Part Location

INFOID:000000001680515

ENGINE COMPARTMENT

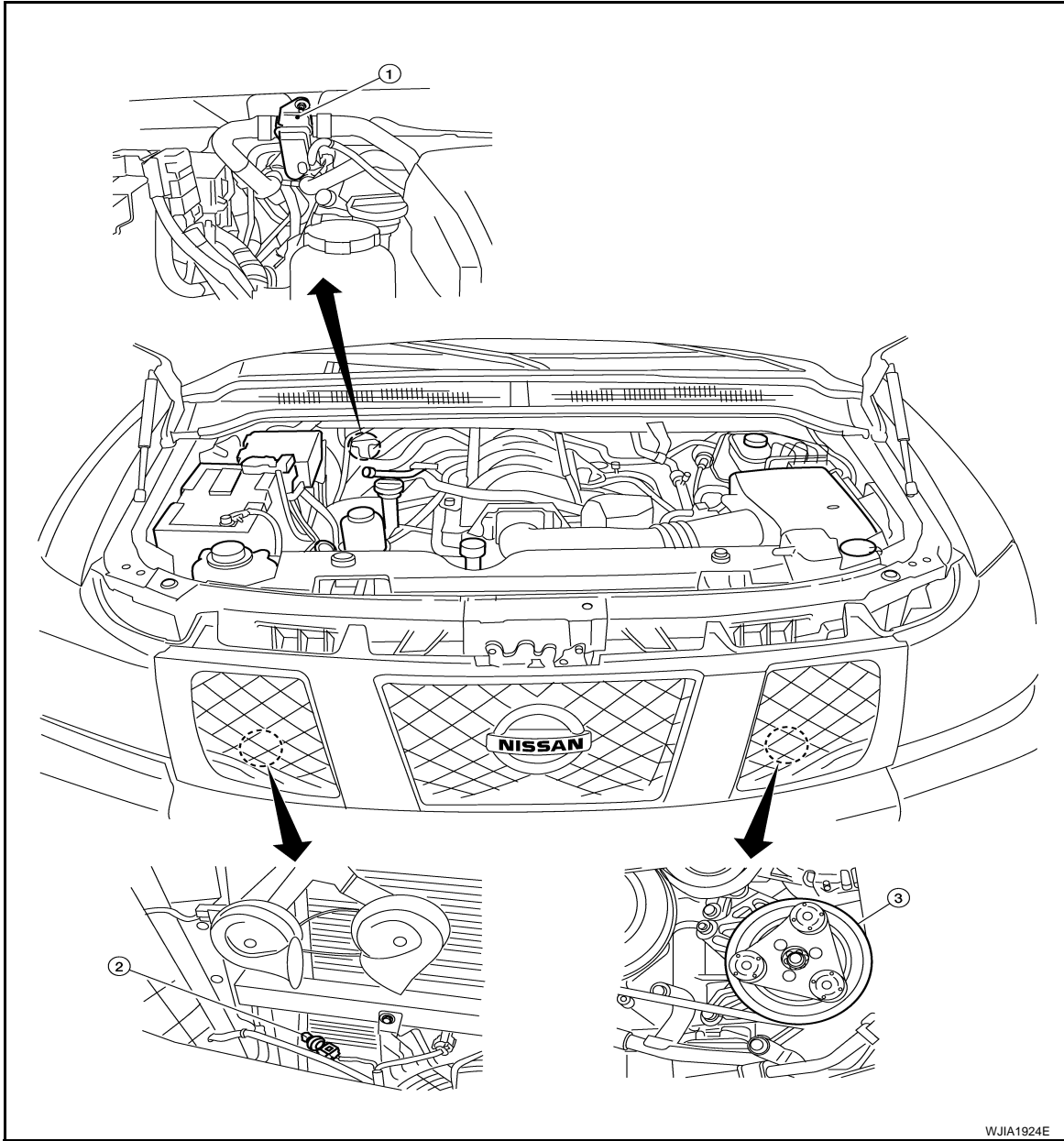

1. Water valve F68

2. Refrigerant pressure sensor E48  
(view with grille removed)

3. A/C Compressor F3

PASSENGER COMPARTMENT

A  
B  
C  
D  
E  
F  
G  
H  
HAC  
J  
K  
L  
M  
N  
O  
P

# FUNCTION INFORMATION

< FUNCTION DIAGNOSIS >

[MANUAL A/C (TYPE 3)]

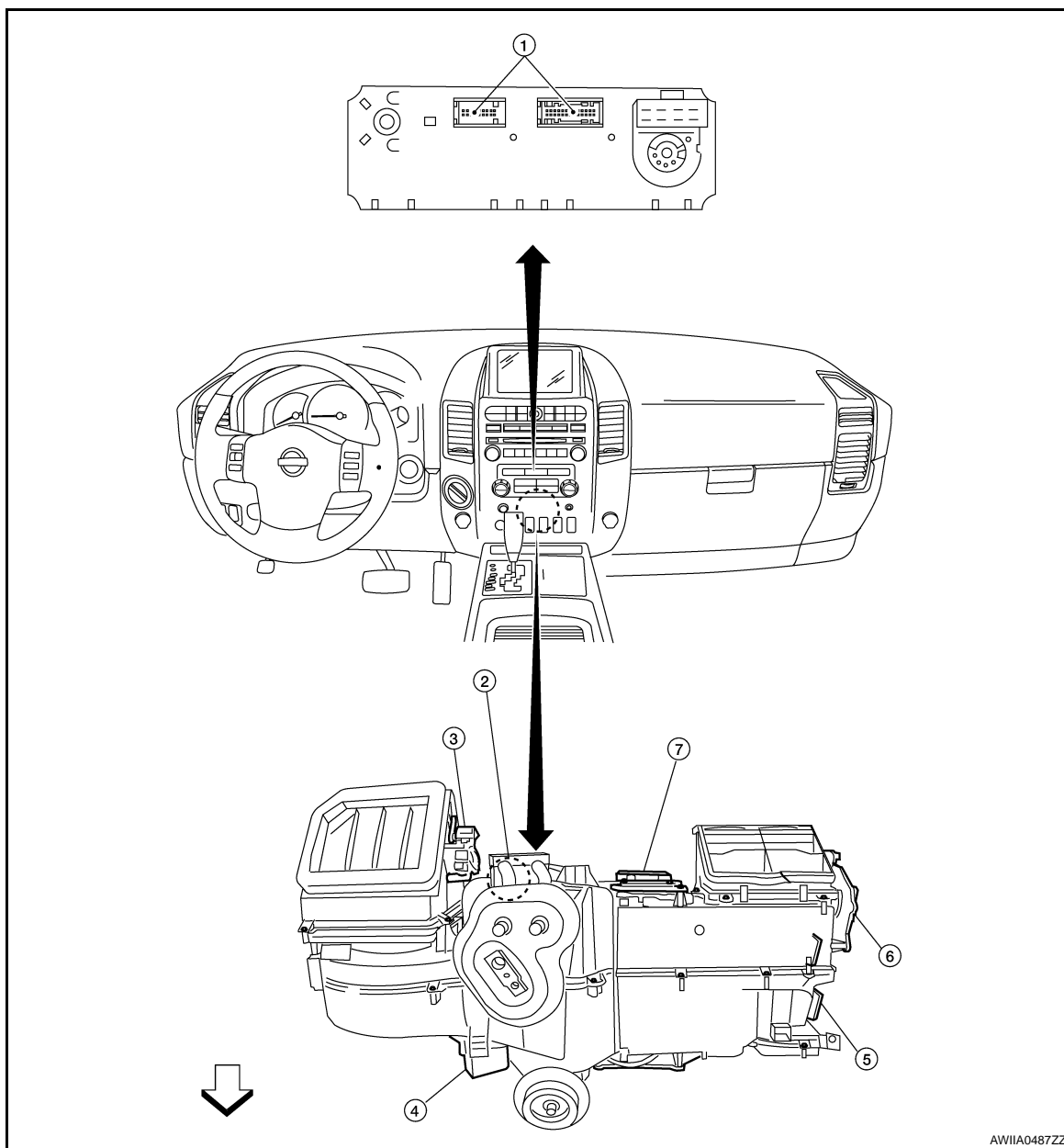

AWIIA0487ZZ

- |                                     |                         |                              |
|-------------------------------------|-------------------------|------------------------------|
| 1. Front air control M49, M50       | 2. Intake sensor M146   | 3. Intake door motor M58     |
| 4. Front blower motor resistor M163 | 5. Mode door motor M142 | 6. Defroster door motor M144 |
| 7. Air mix door motor (front) M147  |                         |                              |



# FUNCTION INFORMATION

< FUNCTION DIAGNOSIS >

[MANUAL A/C (TYPE 3)]

## Symptom Table

INFOID:000000001680516

Symptom	Reference Page	
A/C system does not come on.	Go to Trouble Diagnosis Procedure for A/C System.	<a href="#">HAC-309</a>
Air outlet does not change.	Go to Trouble Diagnosis Procedure for Mode Door Motor.	<a href="#">HAC-274</a>
Mode door motor is malfunctioning.		
Discharge air temperature does not change.	Go to Trouble Diagnosis Procedure for Air Mix Door Motor.	<a href="#">HAC-279</a>
Air mix door motor is malfunctioning.		
Intake door does not change.	Go to Trouble Diagnosis Procedure for Intake Door Motor.	<a href="#">HAC-284</a>
Intake door motor is malfunctioning.		
Defroster door motor is malfunctioning.	Go to Trouble Diagnosis Procedure for Defroster Door Motor.	<a href="#">HAC-287</a>
Front blower motor operation is malfunctioning.	Go to Trouble Diagnosis Procedure for Front Blower Motor.	<a href="#">HAC-292</a>
Magnet clutch does not engage.	Go to Trouble Diagnosis Procedure for Magnet Clutch.	<a href="#">HAC-299</a>
Insufficient cooling	Go to Trouble Diagnosis Procedure for Insufficient Cooling.	<a href="#">HAC-323</a>
Insufficient heating	Go to Trouble Diagnosis Procedure for Insufficient Heating.	<a href="#">HAC-331</a>
Noise	Go to Trouble Diagnosis Procedure for Noise.	<a href="#">HAC-333</a>

A  
B  
C  
D  
E  
F  
G  
H  
J  
K  
L  
M  
N  
O  
P

**HAC**

## REFRIGERATION SYSTEM

### Refrigerant Cycle

INFOID:000000001680517

Refer to [HA-15. "Refrigerant Cycle"](#).

### Refrigerant System Protection

INFOID:000000001680518

Refer to [HA-15. "Refrigerant System Protection"](#).

# MANUAL AIR CONDITIONER SYSTEM

< FUNCTION DIAGNOSIS >

[MANUAL A/C (TYPE 3)]

## MANUAL AIR CONDITIONER SYSTEM

### Control System Diagram

INFOID:000000001680519

### CONTROL SYSTEM

The control system consists of input sensors, switches, the front air control (microcomputer) and outputs. The relationship of these components is shown in the figure below:

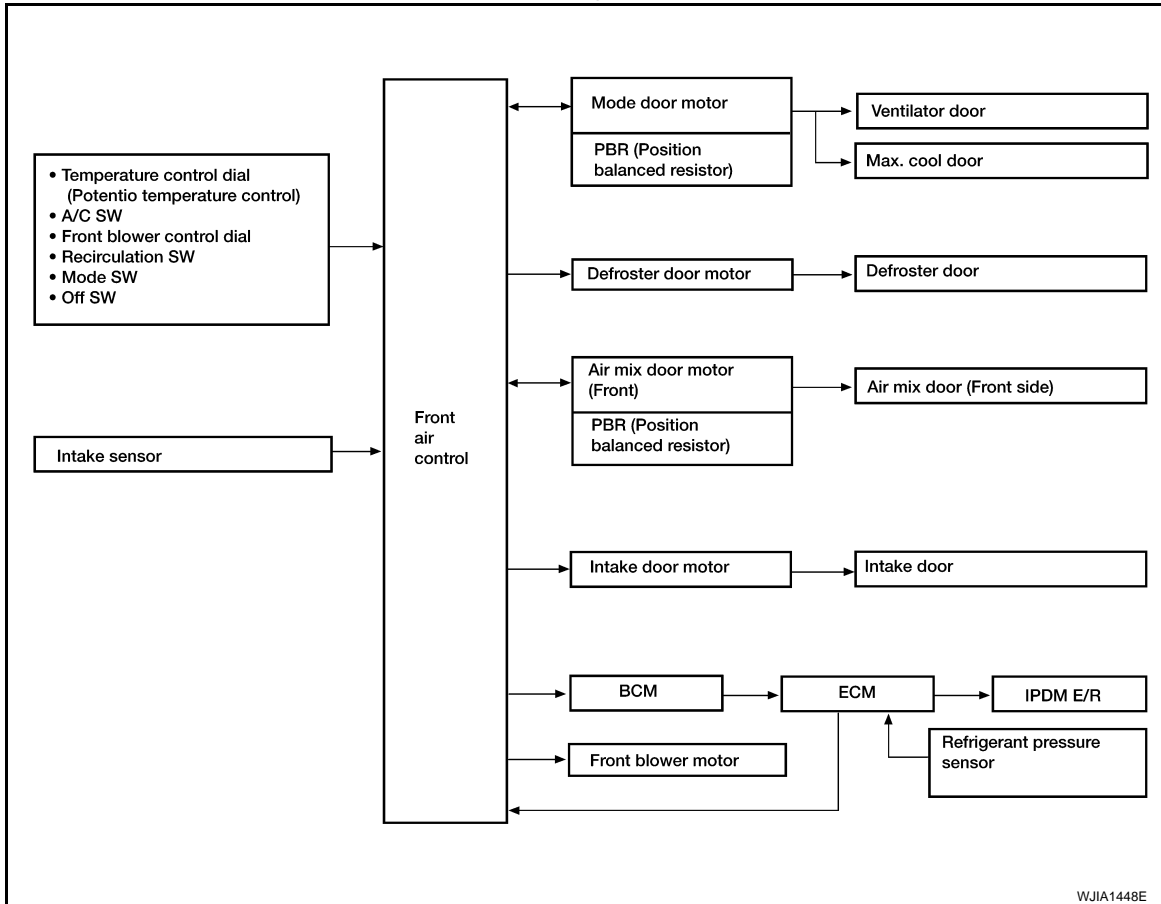

### Control System Description

INFOID:000000001680520

### CONTROL OPERATION

#### Front air control

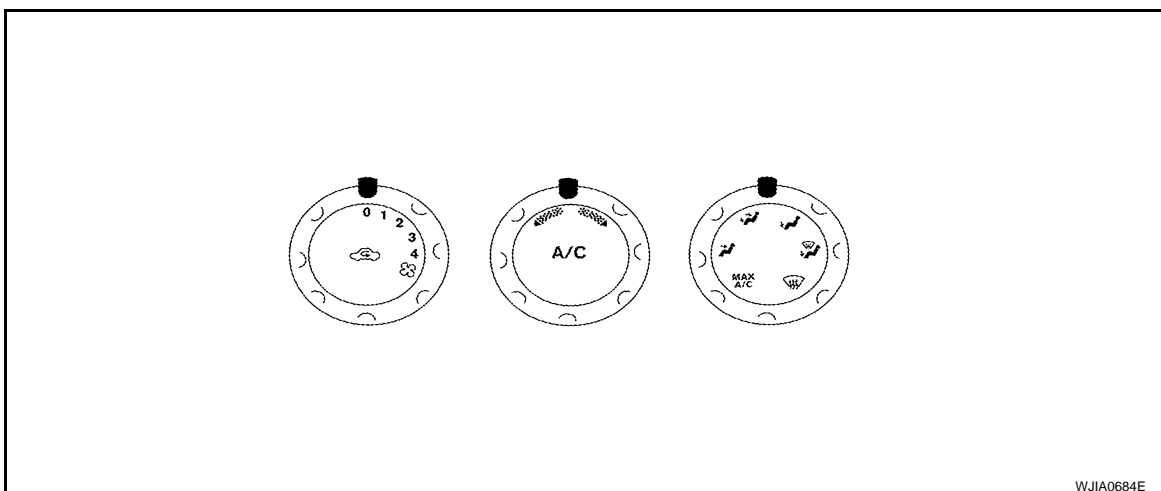

### TEMPERATURE CONTROL DIAL

Increases or decreases the set temperature.

A  
B  
C  
D  
E  
F  
G  
H  
HAC  
J  
K  
L  
M  
N  
O  
P

# MANUAL AIR CONDITIONER SYSTEM

< FUNCTION DIAGNOSIS >

[MANUAL A/C (TYPE 3)]

## RECIRCULATION ( ) SWITCH

- When REC switch is ON, REC switch indicator turns ON, and air inlet is set to REC.
- When REC switch is turned OFF, or when compressor is turned from ON to OFF, REC switch is automatically turned OFF. REC mode can be re-entered by pressing REC switch again.
- REC switch is not operated when DEF switch is turned ON, at the D/F position, or in floor position.

## BLOWER CONTROL DIAL/OFF SWITCH

- The blower speed is manually controlled with this dial.
- The compressor and blower are OFF, the intake doors are set to the outside air position, and the air outlet doors are set to the foot position.

## A/C SWITCH

The compressor is ON or OFF.

(Pressing the A/C switch when the AUTO switch is ON will turn off the A/C switch and compressor.)

## MODE CONTROL DIAL

Controls the air discharge outlets.

## MAGNET CLUTCH CONTROL

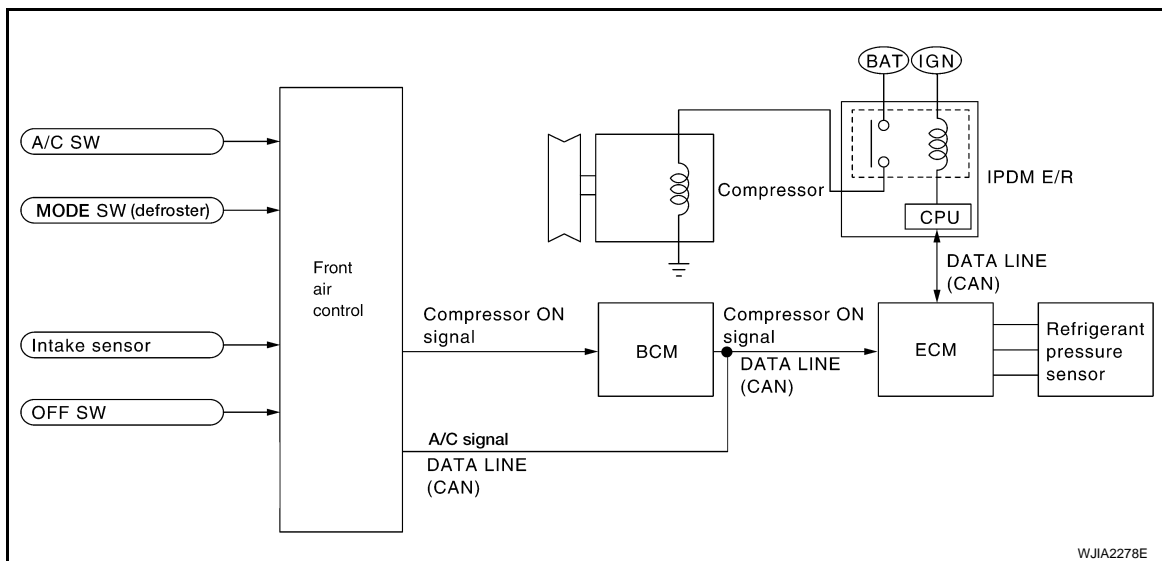

When A/C switch is pressed or DEF position is selected, front air control inputs compressor ON signal to BCM. BCM sends compressor ON signal to ECM and front air control, via CAN communication line.

ECM judges whether compressor can be turned ON, based on each sensor status (refrigerant pressure sensor signal, throttle angle sensor, etc.). If it judges compressor can be turned ON, it sends compressor ON signal to IPDM E/R, via CAN communication line.

Upon receipt of compressor ON signal from ECM, IPDM E/R turns air conditioner relay ON to operate compressor.

## Discharge Air Flow

INFOID:000000001680521

# MANUAL AIR CONDITIONER SYSTEM

< FUNCTION DIAGNOSIS >

[MANUAL A/C (TYPE 3)]

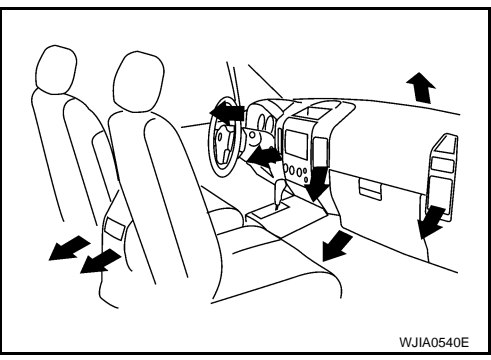

WJIA0540E

Mode door position	Air outlet/distribution		
	Vent	Foot	Defroster
	95%	5%	—
	60%	40%	—
	—	70%	30%
	—	60%	40%
	—	10%	90%

## Switches And Their Control Function

INFOID:000000001680522

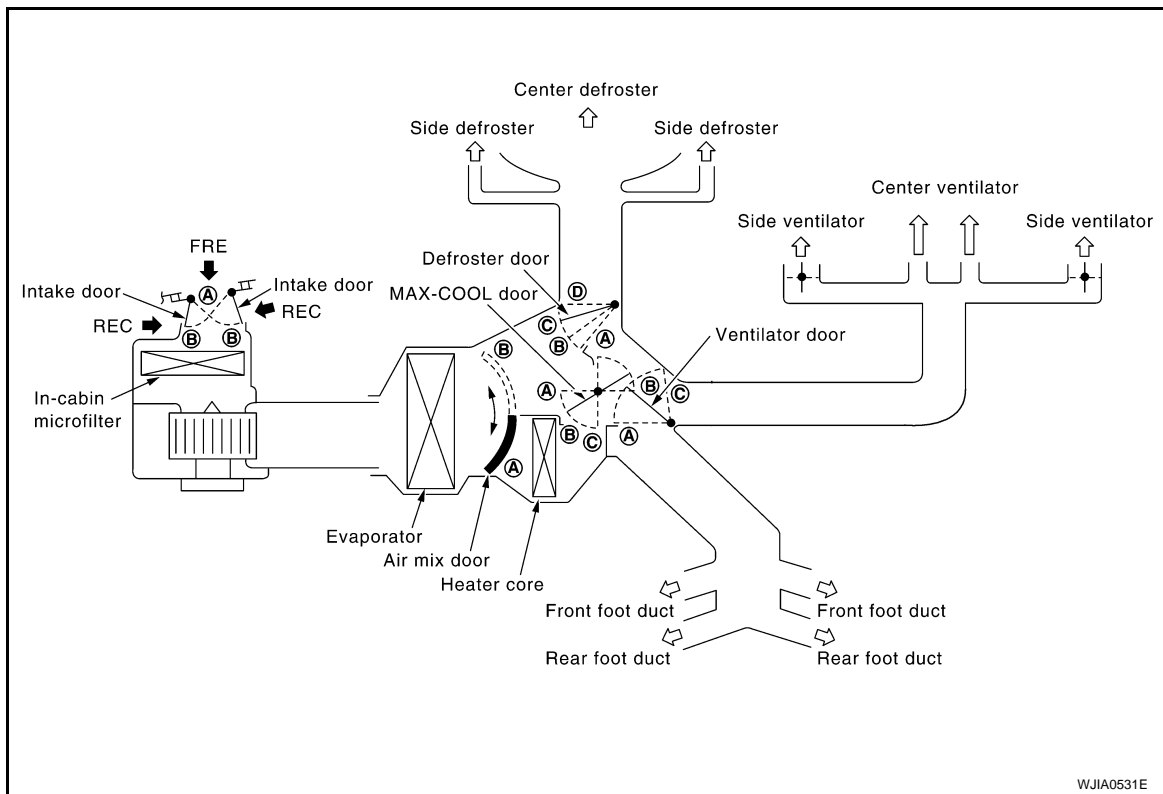

# MANUAL AIR CONDITIONER SYSTEM

< FUNCTION DIAGNOSIS >

[MANUAL A/C (TYPE 3)]

Door	Position or switch	MODE SW				DEF SW		REC SW		Temperature switch			OFF SW
		VENT	B/L	FOOT	D/F	ON	OFF	ON	OFF				
										COLD	~	HOT	
Ventilator door		(A)	(B)	(C)	(C)	(C)	—	—	—	—	—	—	(C)
MAX-COOL door		(A)	(B)	(B)	(B)	(C)	—	—	—	—	—	—	(B)
Defroster door		(D)	(D)	(D <sub>or</sub> C)	(B)	(A)	—	—	—	—	—	—	(C)
Intake door		—				(B)	—	(A)	(B)	—	—	—	(B)
Air mix door		—				—	—	—	—	(A)	—	(B)	—

WJIA0532E

---

CAN COMMUNICATION SYSTEM

System Description

INFOID:000000001680523

Refer to [LAN-4. "System Description"](#).

A

B

C

D

E

F

G

H

**HAC**

J

K

L

M

N

O

P

## DIAGNOSIS SYSTEM (BCM)

### CONSULT-III Function (BCM)

INFOID:000000001680524

CONSULT-III can display each diagnostic item using the diagnostic test modes shown following.

BCM diagnostic test item	Diagnostic mode	Description
Inspection by part	WORK SUPPORT	Supports inspections and adjustments. Commands are transmitted to the BCM for setting the status suitable for required operation, input/output signals are received from the BCM and received data is displayed.
	DATA MONITOR	Displays BCM input/output data in real time.
	ACTIVE TEST	Operation of electrical loads can be checked by sending drive signal to them.
	SELF-DIAG RESULTS	Displays BCM self-diagnosis results.
	CAN DIAG SUPPORT MNTR	The result of transmit/receive diagnosis of CAN communication can be read.
	ECU PART NUMBER	BCM part number can be read.
	CONFIGURATION	Performs BCM configuration read/write functions.

### DATA MONITOR

#### Display Item List

Monitor item name "operation or unit"	Contents
IGN ON SW "ON/OFF"	Displays "IGN Position (ON)/OFF, ACC Position (OFF)" status as judged from ignition switch signal.
COMP ON SIG "ON/OFF"	Displays "COMP (ON)/COMP (OFF)" status as judged from air conditioner switch signal.
FAN ON SIG "ON/OFF"	Displays "FAN (ON)/FAN (OFF)" status as judged from blower motor switch signal.



# MANUAL A/C IDENTIFICATION TABLE

< COMPONENT DIAGNOSIS >

[MANUAL A/C (TYPE 3)]

## COMPONENT DIAGNOSIS

### MANUAL A/C IDENTIFICATION TABLE

#### Application Table

INFOID:000000001680525

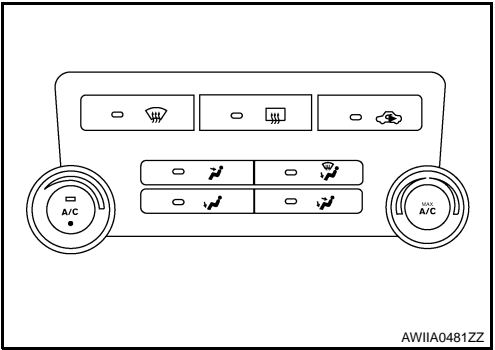
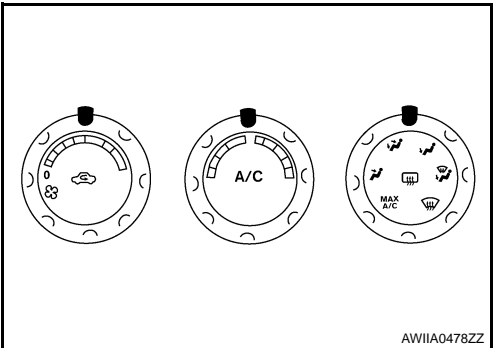
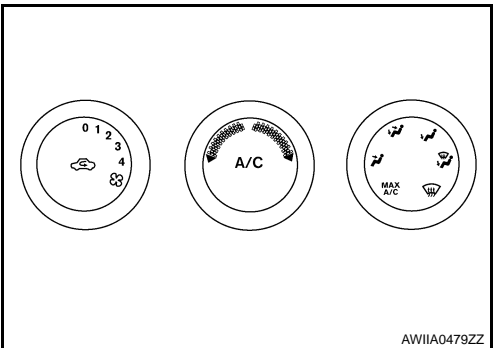
Manual A/C Type	Description	Visual Identification
Manual A/C (Type 1)	Two Control Dial System	 <p>AWIIA0481ZZ</p>
Manual A/C (Type 2)	Three Control Dial System [with variable blower control (VBC)]	 <p>AWIIA0478ZZ</p>
Manual A/C (Type 3)	Three Control Dial System [(without variable blower control (VBC))]	 <p>AWIIA0479ZZ</p>

A  
B  
C  
D  
E  
F  
G  
H  
J  
K  
L  
M  
N  
O  
P

**HAC**

## MODE DOOR MOTOR

### System Description

INFOID:000000001680526

### SYSTEM DESCRIPTION

#### Component Parts

Mode door control system components are:

- Front air control
- Mode door motor
- PBR (built into mode door motor)
- Intake sensor

#### System Operation

The mode door position (vent, B/L, foot, D/F, and defrost) is set by the front air control by means of the mode door motor. When a mode door position is selected on the front air control, voltage is applied to one circuit of the mode door motor while ground is applied to the other circuit, causing the mode door motor to rotate. The direction of rotation is determined by which circuit has voltage applied to it, and which one has ground applied to it. The front air control monitors the mode door position by measuring the voltage signal on the PBR circuit.

### COMPONENT DESCRIPTION

#### Mode Door Motor

The mode door motor is attached to the heater & cooling unit assembly. It rotates so that air is discharged from the outlet as indicated by the front air control. Motor rotation is conveyed to a link which activates the mode door.

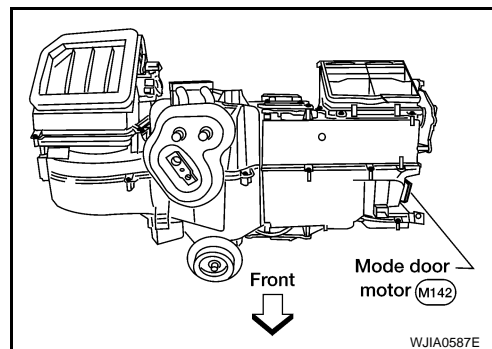

### Mode Door Motor Component Function Check



INFOID:000000001680527

### INSPECTION FLOW

#### 1. CONFIRM SYMPTOM BY PERFORMING OPERATIONAL CHECK - DISCHARGE AIR

1. Rotate the mode control dial and check each position and press the  (DEF) mode.
2. Confirm that discharge air comes out according to the air distribution table. Refer to [HAC-268, "Discharge Air Flow"](#).

**NOTE:**

Confirm that the compressor clutch is engaged (visual inspection) and intake door position is at FRESH  when DEF () or D/F () is selected.

Can a symptom be duplicated?

- YES >> GO TO 3.  
NO >> GO TO 2.

#### 2. PERFORM COMPLETE OPERATIONAL CHECK

Perform a complete operational check and check for any symptoms. Refer to [HAC-260, "Operational Check"](#).

Can a symptom be duplicated?

- YES >> Refer to [HAC-259, "How to Perform Trouble Diagnosis For Quick And Accurate Repair"](#).  
NO >> System OK.

#### 3. CHECK FOR SERVICE BULLETINS

Check for any service bulletins.

# MODE DOOR MOTOR

[MANUAL A/C (TYPE 3)]

## < COMPONENT DIAGNOSIS >

>> GO TO 4.

### 4. CHECK MODE DOOR OPERATION

Check and verify mode door mechanism for smooth operation in each mode.

Is the inspection result normal?

YES >> GO TO 5.

NO >> Repair as necessary.

### 5. CHECK THE MODE DOOR MOTOR PBR CIRCUIT

Perform diagnostic procedure for the mode door motor. Refer to [HAC-274. "Mode Door Motor Component Function Check"](#).

Is the inspection result normal?

YES >> GO TO 6.

NO >> Repair PBR circuit or replace motor. Refer to [HAC-275. "Mode Door Motor Diagnosis Procedure"](#).

### 6. RECHECK FOR SYMPTOMS

Perform a complete operational check and check for any symptoms. Refer to [HAC-260. "Operational Check"](#).

Does another symptom exist?

YES >> Repair as necessary.

NO >> Replace front air control Refer to [VTL-8. "Removal and Installation"](#).

## Mode Door Motor Diagnosis Procedure

INFOID:000000001680528

SYMPTOM:

- Air outlet does not change.
- Mode door motor does not operate normally.

### 1. CHECK FRONT AIR CONTROL FOR POWER AND GROUND

1. Turn ignition switch ON.
2. Press the B/L (↺) mode switch.
3. Check voltage between front air control harness connector M49 terminal 5 and terminal 6 while pressing the mode switch to the floor (↵) mode.

Connector	Terminals		Condition	Voltage (Approx.)
	(+)	(-)		
Front air control: M49	6	5	Press mode switch	Battery voltage

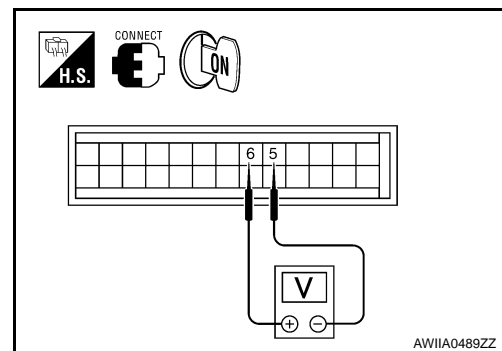

Is the inspection result normal?

YES >> GO TO 4.

NO >> GO TO 3.

### 2. CHECK MODE DOOR MOTOR CIRCUITS FOR SHORT TO GROUND

1. Turn ignition switch OFF.
2. Disconnect the front air control harness connector.
3. Check continuity between front air control harness connector M49 terminal 5, 6 and ground.

**5 - Ground : Continuity should not exist.**

**6 - Ground : Continuity should not exist.**

Is the inspection result normal?

YES >> Replace front air control. Refer to [VTL-8. "Removal and Installation"](#).

NO >> Repair or replace harness as necessary.

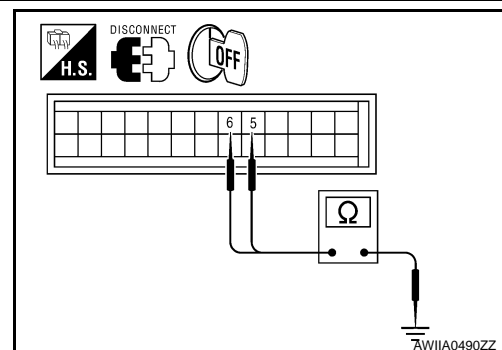

# MODE DOOR MOTOR

< COMPONENT DIAGNOSIS >

[MANUAL A/C (TYPE 3)]

## 3. CHECK FRONT AIR CONTROL FOR GROUND AND POWER

1. Press the mode switch to the D/F ( ) mode.
2. Check voltage between front air control harness connector M49 terminal 5 and terminal 6 while pressing the mode switch to the vent ( ) mode.

Connector	Terminals		Condition	Voltage (Approx.)
	(+)	(-)		
Front air control: M49	5	6	Press mode switch	Battery voltage

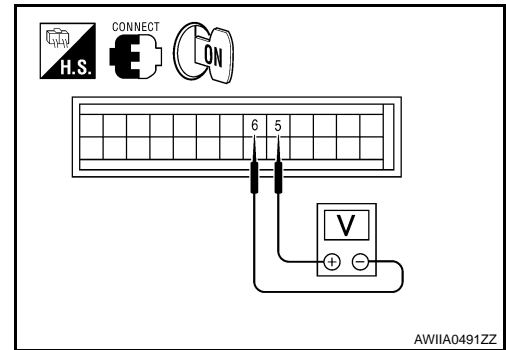

Is the inspection result normal?

- YES >> GO TO 5.  
 NO >> Replace front air control. Refer to [VTL-8. "Removal and Installation"](#).

## 4. CHECK MODE DOOR MOTOR AND CIRCUITS FOR OPEN

1. Turn ignition switch OFF.
2. Disconnect the front air control harness connector.
3. Check continuity between front air control harness connector M49 terminal 5 and terminal 6.

**Continuity should exist.**

Is the inspection result normal?

- YES >> GO TO 7.  
 NO >> GO TO 6.

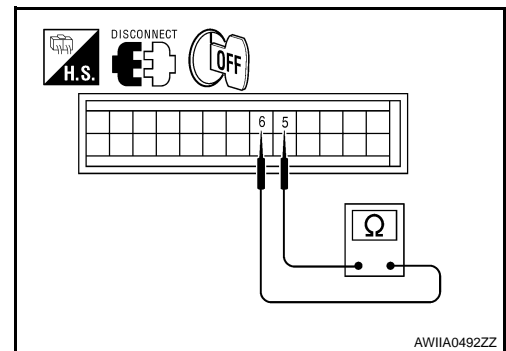

## 5. CHECK MODE DOOR MOTOR CIRCUITS FOR OPEN

1. Disconnect the mode door motor harness connector.
2. Check continuity between front air control harness connector M49 (A) terminal 5, 6 and the mode door motor harness connector M142 (B) terminal 5, 6.

**5 - 5 : Continuity should exist.**  
**6 - 6 : Continuity should exist.**

Is the inspection result normal?

- YES >> Replace mode door motor. Refer to [VTL-19. "Removal and Installation"](#).  
 NO >> Repair or replace harness as necessary.

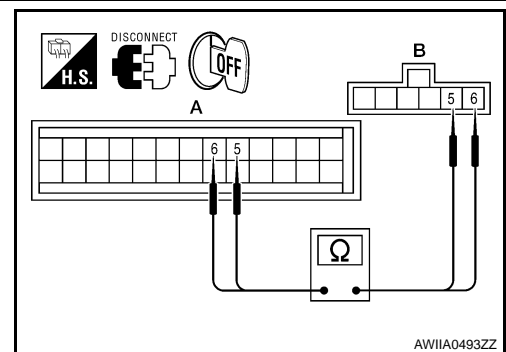

## 6. CHECK FRONT AIR CONTROL FOR PBR POWER AND GROUND

1. Reconnect front air control harness connector.
2. Turn ignition switch ON.
3. Check voltage between front air control harness connector M49 terminal 2 and 15.

Connector	Terminals		Voltage (Approx.)
	(+)	(-)	
Front air control: M49, M50	2	15	5V

Is the inspection result normal?

- YES >> GO TO 9.  
 NO >> GO TO 8.

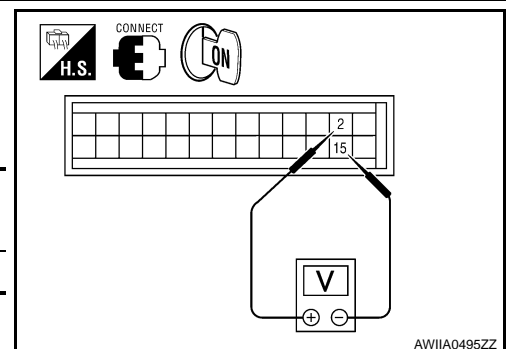

## 7. CHECK PBR REFERENCE VOLTAGE CIRCUIT FOR SHORT TO GROUND

# MODE DOOR MOTOR

## < COMPONENT DIAGNOSIS >

[MANUAL A/C (TYPE 3)]

1. Turn ignition switch OFF.
2. Disconnect the front air control harness connector.
3. Check continuity between front air control harness connector M49 terminal 2 and ground.

**Continuity should not exist.**

Is the inspection result normal?

- YES >> Replace front air control Refer to [VTL-8, "Removal and Installation"](#).
- NO >> Repair or replace harness as necessary.

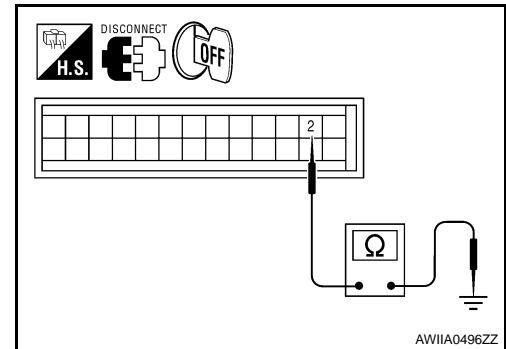

## 8.CHECK PBR REFERENCE VOLTAGE AND GROUND CIRCUITS

1. Turn ignition switch OFF.
2. Disconnect the front air control harness connector.
3. Check continuity between front air control harness connector M49 terminal 2 and terminal 15.

**Continuity should exist.**

Is the inspection result normal?

- YES >> GO TO 11.
- NO >> GO TO 10

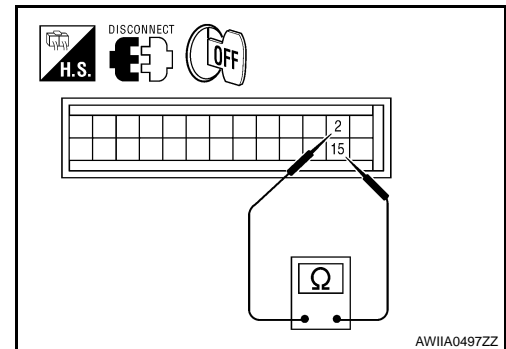

## 9.CHECK PBR REFERENCE VOLTAGE CIRCUIT FOR OPEN

1. Disconnect the mode door motor harness connector.
2. Check continuity between mode door motor harness connector M142 (B) terminal 3, 1 and front air control harness connector M49 (C) terminal 3, M50 (A) terminal 28.

**2 - 3 : Continuity should exist.**

**15 - 1 : Continuity should exist.**

Is the inspection result normal?

- YES >> Replace mode door motor. Refer to [VTL-19, "Removal and Installation"](#).
- NO >> Repair or replace harness as necessary.

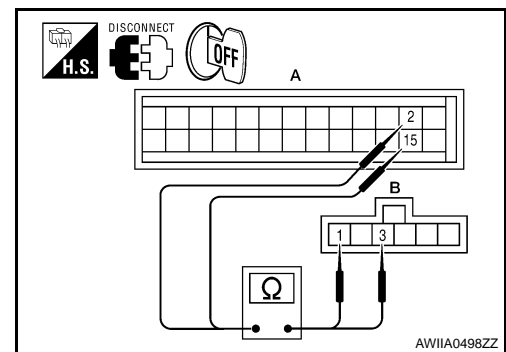

## 10.CHECK PBR FEEDBACK VOLTAGE

1. Reconnect the front air control harness connector.
2. Turn ignition switch ON.
3. Check voltage between front air control harness connector M49 terminal 16 and ground while cycling mode switch through all modes.

**Voltage : Approx. 1V - 4.5V**

Is the inspection result normal?

- YES >> GO TO 13.
- NO >> GO TO 12.

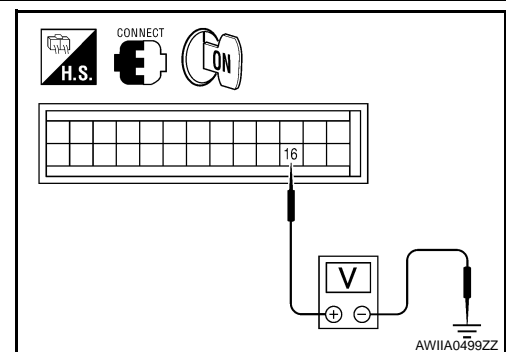

## 11.CHECK PBR FEEDBACK SIGNAL CIRCUIT FOR SHORT TO GROUND

# MODE DOOR MOTOR

[MANUAL A/C (TYPE 3)]

## < COMPONENT DIAGNOSIS >

1. Turn ignition switch OFF.
2. Disconnect front air control harness connector.
3. Check continuity between front air control harness connector M49 terminal 16 and ground.

**Continuity should not exist.**

Is the inspection result normal?

- YES >> Replace front air control Refer to [VTL-8, "Removal and Installation"](#).
- NO >> Repair or replace harness as necessary.

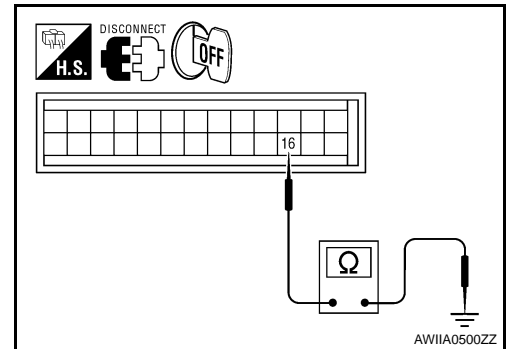

## 12.CHECK PBR FEEDBACK CIRCUIT FOR OPEN

1. Turn ignition switch OFF.
2. Disconnect the mode door motor harness connector and front air control harness connector.
3. Check continuity between mode door motor harness connector M142 terminal 2 and front air control harness connector M49 terminal 16.

**Continuity should exist.**

Is the inspection result normal?

- YES >> Replace mode door motor. Refer to [VTL-19, "Removal and Installation"](#).
- NO >> Repair or replace harness as necessary.

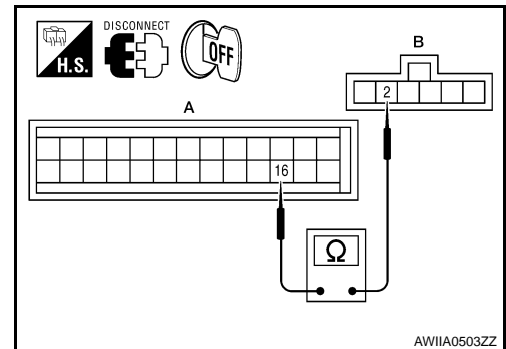

## AIR MIX DOOR MOTOR

### System Description

INFOID:000000001680529

### SYSTEM DESCRIPTION

#### SYMPTOM:

- Discharge air temperature does not change.
- Air mix door motor does not operate.

### SYSTEM DESCRIPTION

#### Component Parts

Air mix door control system components are:

- Front air control
- Air mix door motor
- PBR (built-into air mix door motors)
- Intake sensor

#### System Operation

The front air control receives data from the temperature selected by the driver side, passenger side, and rear. The front air control then applies a voltage to one circuit of the appropriate air mix door motor, while ground is applied to the other circuit, causing the appropriate air mix door motor to rotate. The direction of rotation is determined by which circuit has voltage applied to it, and which one has ground applied to it. The front air control monitors the air mix door positions by measuring the voltage signal on the PBR circuits of each door.

#### Air Mix Door Control Specification

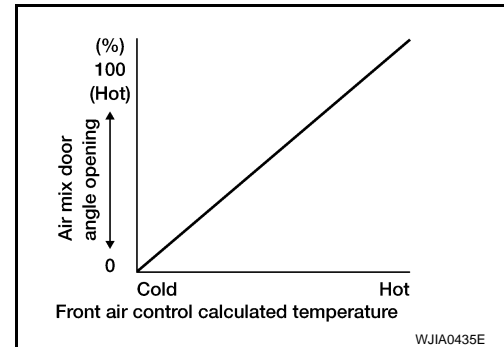

### COMPONENT DESCRIPTION

#### Air Mix Door Motors

The air mix door motor is attached to the front heater & cooling unit assembly. The motor rotates so that the air mix door is opened or closed to a position set by the front air control. Motor rotation is then conveyed through a shaft and the air mix door position is then fed back to the front air control by the PBR built into the air mix door motor.

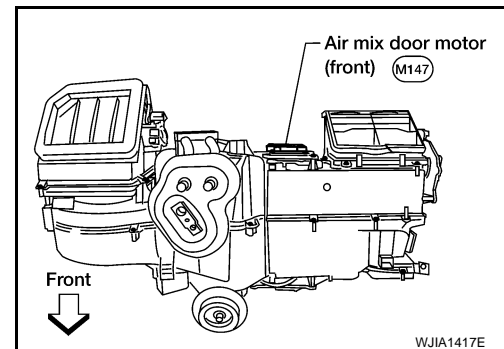

### Air Mix Door Motor Component Function Check

INFOID:000000001680530

### INSPECTION FLOW

#### 1. CONFIRM SYMPTOM BY PERFORMING OPERATIONAL CHECK - TEMPERATURE INCREASE

1. Turn the temperature control dial clockwise to maximum hot.
2. Check for hot air at discharge air outlets.

>> GO TO 2.

## 2. CONFIRM SYMPTOM BY PERFORMING OPERATIONAL CHECK - TEMPERATURE DECREASE

1. Turn the temperature control dial counterclockwise to maximum cold.
2. Check for cold air at discharge air outlets.

Can a symptom be duplicated?

- YES >> GO TO 4.  
NO >> GO TO 3.

## 3. PERFORM COMPLETE OPERATIONAL CHECK

Perform a complete operational check and check for any symptoms. Refer to [HAC-260, "Operational Check"](#).

Can a symptom be duplicated?

- YES >> Refer to [HAC-259, "How to Perform Trouble Diagnosis For Quick And Accurate Repair"](#).  
NO >> System OK.

## 4. CHECK FOR SERVICE BULLETINS

Check for any service bulletins.

>> GO TO 5.

## 5. CHECK AIR MIX DOOR OPERATION

Check and verify air mix door mechanism for smooth operation from maximum cold °to maximum hot in each mode.

Is the inspection result normal?

- YES >> GO TO 6.  
NO >> Repair as necessary.

## 6. CHECK THE AIR MIX DOOR MOTOR PBR CIRCUIT

Perform diagnostic procedure for the air mix door motor. Refer to [HAC-279, "Air Mix Door Motor Component Function Check"](#).

Is the inspection result normal?

- YES >> GO TO 7.  
NO >> Repair PBR circuit or replace air mix door motor. Refer to [VTL-20, "Removal and Installation"](#).

## 7. RECHECK FOR ANY SYMPTOMS

Perform a complete operational check for any symptoms. Refer to [HAC-260, "Operational Check"](#).

Does another symptom exist?

- YES >> Refer to [HAC-259, "How to Perform Trouble Diagnosis For Quick And Accurate Repair"](#).  
NO >> Replace front air control Refer to [VTL-8, "Removal and Installation"](#).

## Air Mix Door Motor Diagnosis Procedure

INFOID:000000001680531

SYMPTOM:

- Discharge air temperature does not change.
- Air mix door motor does not operate.

## DIAGNOSTIC PROCEDURE FOR AIR MIX DOOR MOTOR

### 1. CHECK FRONT AIR CONTROL FOR POWER AND GROUND



# AIR MIX DOOR MOTOR

[MANUAL A/C (TYPE 3)]

## < COMPONENT DIAGNOSIS >

1. Turn ignition switch ON.
2. Rotate temperature control dial to maximum hot.
3. Check voltage between front air control harness connector M49 terminal 3 and terminal 4 while rotating temperature control dial to maximum cold.

Connector	Terminals		Condition	Voltage (Approx.)
	(+)	(-)		
Front air control: M49	3	4	Rotate temp control dial	Battery voltage

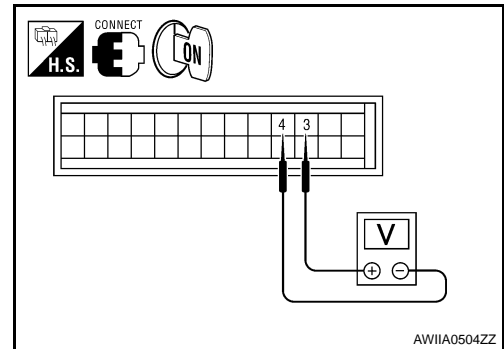

Is the inspection result normal?

- YES >> GO TO 4.  
NO >> GO TO 3.

## 2.CHECK AIR MIX DOOR MOTOR CIRCUITS FOR SHORT TO GROUND

1. Turn ignition switch OFF.
2. Disconnect the front air control harness connector.
3. Check continuity between front air control harness connector M49 terminal 3, 4 and ground.

- 3 - Ground : Continuity should not exist.**  
**4 - Ground : Continuity should not exist.**

Is the inspection result normal?

- YES >> Replace front air control. Refer to [VTL-8, "Removal and Installation"](#).  
NO >> Repair or replace harness as necessary.

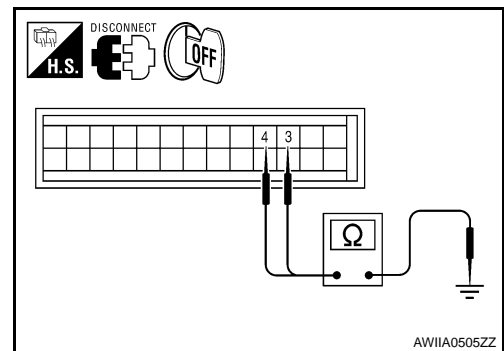

## 3.CHECK FRONT AIR CONTROL FOR POWER AND GROUND

1. Turn ignition switch ON.
2. Rotate temperature control dial to maximum hot.
3. Check voltage between front air control harness connector M49 terminal 3 and terminal 4 while rotating temperature control dial to maximum cold.

Connector	Terminals		Condition	Voltage (Approx.)
	(+)	(-)		
Front air control: M49	4	3	Rotate temp control dial	Battery voltage

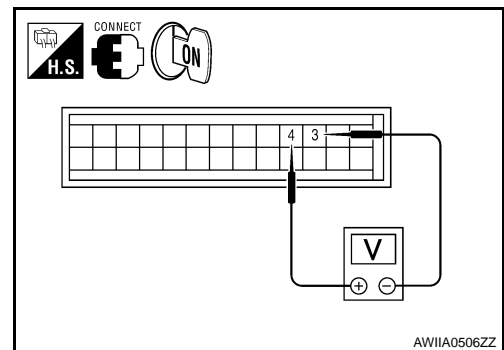

Is the inspection result normal?

- YES >> GO TO 5.  
NO >> Replace front air control. Refer to [VTL-8, "Removal and Installation"](#).

## 4.CHECK AIR MIX DOOR MOTOR CIRCUITS FOR OPEN

1. Turn ignition switch OFF.
2. Disconnect the front air control harness connector.
3. Check continuity between front air control harness connector M49 terminal 3 and terminal 4.

**Continuity should exist.**

Is the inspection result normal?

- YES >> GO TO 7.  
NO >> GO TO 6.

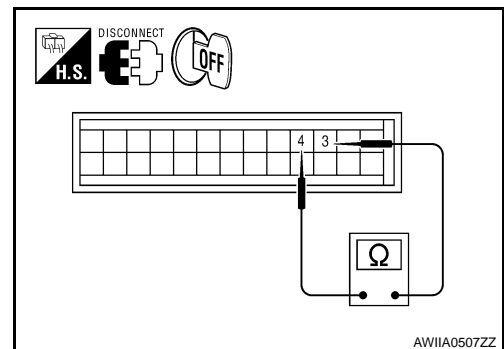

## 5.CHECK AIR MIX DOOR MOTOR CIRCUITS FOR OPEN

A  
B  
C  
D  
E  
F  
G  
H  
HAC  
J  
K  
L  
M  
N  
O  
P

# AIR MIX DOOR MOTOR

## < COMPONENT DIAGNOSIS >

[MANUAL A/C (TYPE 3)]

1. Disconnect the air mix door motor harness connector.
2. Check continuity between front air control harness connector M49 (A) terminal 3, 4 and the air mix door motor harness connector M147 (B) terminal 1, 6.

**3 - 1 : Continuity should exist.**  
**4 - 6 : Continuity should exist.**

Is the inspection result normal?

- YES >> Replace air mix door motor. Refer to [VTL-20. "Removal and Installation"](#).  
 NO >> Repair or replace harness as necessary.

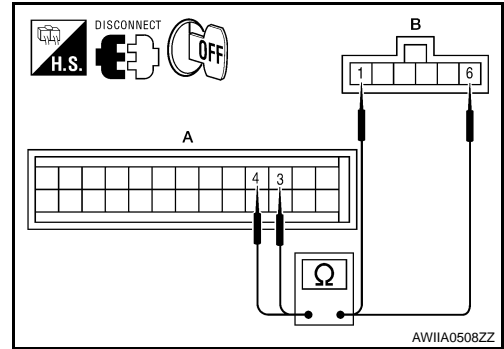

## 6. CHECK FRONT AIR CONTROL FOR PBR POWER AND GROUND

1. Reconnect front air control harness connector.
2. Turn ignition switch ON.
3. Check voltage between front air control harness connector M49 terminal 2 and 15

Connector	Terminals		Voltage (Approx.)
	(+)	(-)	
Front air control: M49	2	15	5V

Is the inspection result normal?

- YES >> GO TO 9.  
 NO >> GO TO 8.

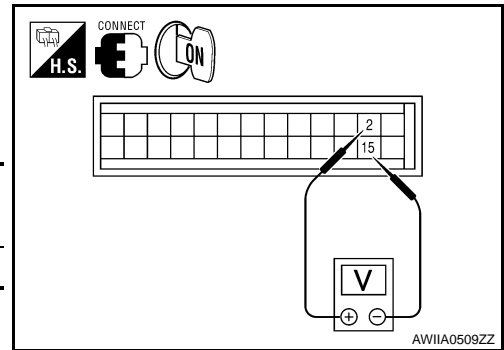

## 7. CHECK PBR REFERENCE VOLTAGE CIRCUIT FOR SHORT TO GROUND

1. Turn ignition switch OFF.
2. Disconnect the front air control harness connector.
3. Check continuity between front air control harness connector M49 terminal 2 and ground.

**Continuity should not exist.**

Is the inspection result normal?

- YES >> Replace front air control. Refer to [VTL-8. "Removal and Installation"](#).  
 NO >> Repair or replace harness as necessary.

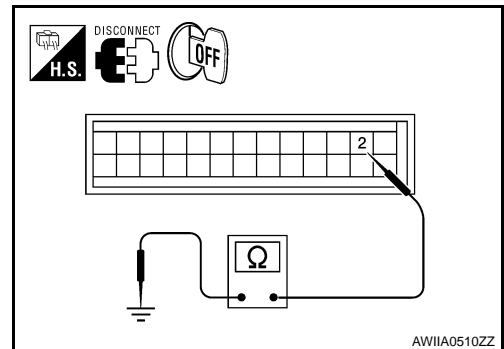

## 8. CHECK PBR REFERENCE VOLTAGE AND GROUND CIRCUITS

1. Turn ignition switch OFF.
2. Disconnect the front air control harness connector.
3. Check continuity between front air control harness connector M49 terminal 2 and 15.

**Continuity should exist.**

Is the inspection result normal?

- YES >> GO TO 11.  
 NO >> GO TO 10.

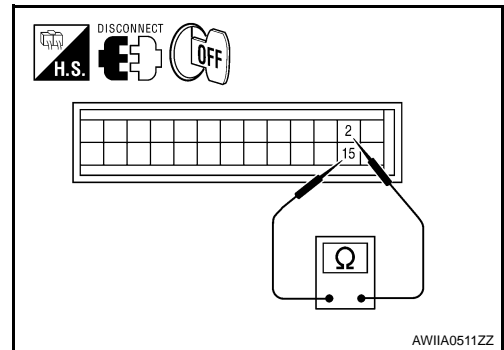

## 9. CHECK PBR REFERENCE VOLTAGE CIRCUIT FOR OPEN

# AIR MIX DOOR MOTOR

[MANUAL A/C (TYPE 3)]

## < COMPONENT DIAGNOSIS >

1. Disconnect the air mix door motor harness connector.
2. Check continuity between air mix door motor harness connector M147 (B) terminal 3, 2 and front air control harness connector M49 (A) terminal 2 and 15.

**2 - 3 : Continuity should exist.**

**15 - 2 : Continuity should exist.**

Is the inspection result normal?

YES >> Replace air mix door motor. Refer to [VTL-20, "Removal and Installation"](#).

NO >> Repair or replace harness as necessary.

## 10. CHECK PBR FEEDBACK VOLTAGE

1. Reconnect the front air control harness connector.
2. Turn ignition switch ON.
3. Check voltage between front air control harness connector M49 terminal 18 and ground while rotating temperature control dial from maximum hot to maximum cold.

**Voltage : Approx. .5V - 4.5V**

Is the inspection result normal?

YES >> GO TO 13.

NO >> GO TO 12.

## 11. CHECK PBR FEEDBACK SIGNAL CIRCUIT FOR SHORT TO GROUND

1. Turn ignition switch OFF.
2. Disconnect front air control harness connector.
3. Check continuity between front air control harness connector M49 terminal 18 and ground.

**Continuity should not exist.**

Is the inspection result normal?

YES >> Replace front air control. Refer to [VTL-8, "Removal and Installation"](#).

NO >> Repair or replace harness as necessary.

## 12. CHECK PBR FEEDBACK CIRCUIT FOR OPEN

1. Turn ignition switch OFF.
2. Disconnect the air mix door motor harness connector and front air control harness connector.
3. Check continuity between air mix door motor harness connector M147 (B) terminal 4 and front air control harness connector M49 (A) terminal 18.

**Continuity should exist.**

Is the inspection result normal?

YES >> Replace air mix door motor. Refer to [VTL-20, "Removal and Installation"](#).

NO >> Repair or replace harness as necessary.

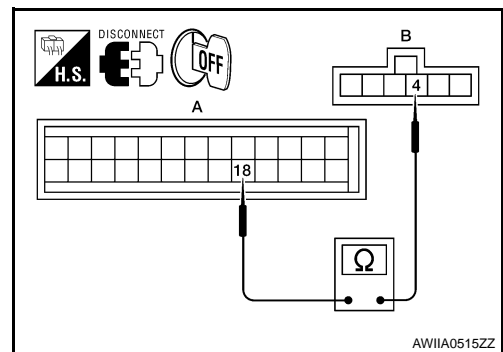
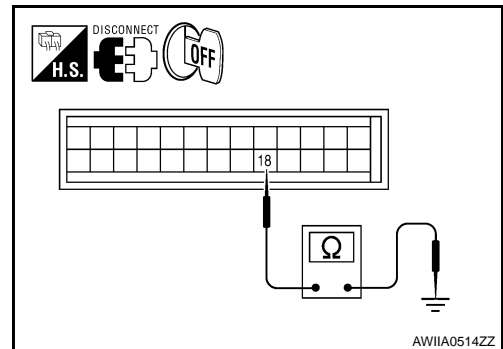
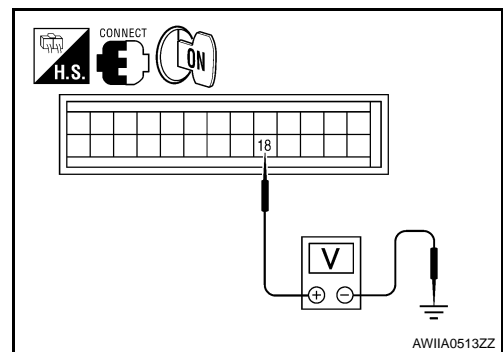
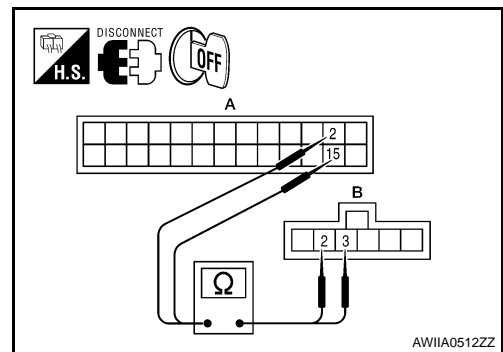

A  
B  
C  
D  
E  
F  
G  
H  
HAC  
J  
K  
L  
M  
N  
O  
P

## INTAKE DOOR MOTOR

### System Description

INFOID:000000001680532

#### SYSTEM DESCRIPTION

**SYMPTOM:**

- Intake door motor does not operate normally.
- Intake door does not change.

#### SYSTEM DESCRIPTION

##### Component Parts

Intake door control system components are:

- Front air control
- Intake door motor (PBR built into the intake door motor)
- Intake sensor

##### System Operation

The intake door control determines the intake door position based on the position of the recirculation switch. When the recirculation switch is depressed the intake door motor rotates closing off the fresh air inlet and recirculating the cabin air. If the recirculation switch is depressed again, the intake door motor rotates in the opposite direction, again allowing fresh air into the cabin.

##### Intake Door Control Specification

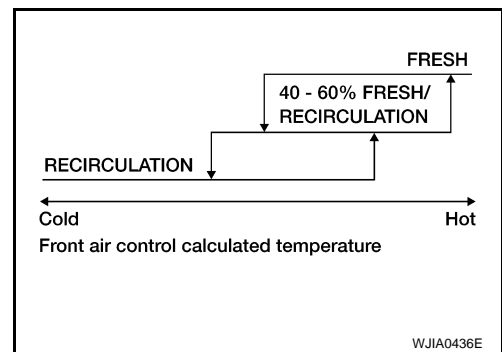

#### COMPONENT DESCRIPTION

##### Intake door motor

The intake door motor is attached to the intake unit. It rotates so that air is drawn from inlets set by the front air control. Motor rotation is conveyed to a lever which activates the intake door.

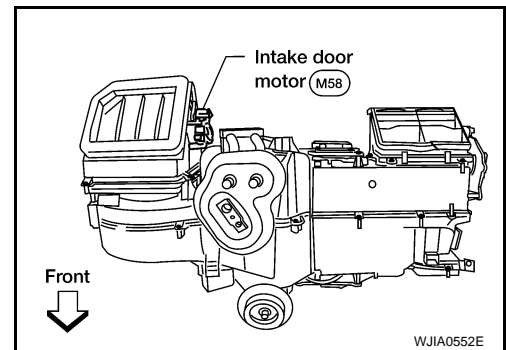

### Intake Door Motor Component Function Check

INFOID:000000001680533

#### INSPECTION FLOW

#### 1. CONFIRM SYMPTOM BY PERFORMING OPERATIONAL CHECK - REC ( )

1. Press the vent mode switch ( ).
2. Press REC ( ) switch. The REC ( ) indicator should illuminate.
3. Press REC ( ) switch again. The REC ( ) indicator should go out.
4. Listen for intake door position change (you should hear blower sound change slightly).

# INTAKE DOOR MOTOR

< COMPONENT DIAGNOSIS >

[MANUAL A/C (TYPE 3)]

Can a symptom be duplicated?

- YES >> GO TO 3.
- NO >> GO TO 2.

## 2.PERFORM COMPLETE OPERATIONAL CHECK

Perform a complete operational check and check for any symptoms. Refer to [HAC-260. "Operational Check"](#).

Can a symptom be duplicated?

- YES >> Refer to [HAC-259. "How to Perform Trouble Diagnosis For Quick And Accurate Repair"](#).
- NO >> System OK.

## 3.CHECK FOR SERVICE BULLETINS

Check for any service bulletins.

>> GO TO 4.

## 4.CHECK INTAKE DOOR OPERATION

Check and verify intake door mechanism for smooth operation.

Is the inspection result normal?

- YES >> GO TO 5.
- NO >> Repair intake door mechanism.

## 5.RECHECK FOR ANY SYMPTOMS

Perform a complete operational check for any symptoms. Refer to [HAC-260. "Operational Check"](#).

Does another symptom exist?

- YES >> Refer to [HAC-259. "How to Perform Trouble Diagnosis For Quick And Accurate Repair"](#).
- NO >> Replace front air control. Refer to [VTL-8. "Removal and Installation"](#).

## Intake Door Motor Diagnosis Procedure

INFOID:000000001680534

HAC

SYMPTOM:

- Intake door does not change.
- Intake door motor does not operate normally.

## DIAGNOSTIC PROCEDURE FOR INTAKE DOOR MOTOR

### 1.CHECK FRONT AIR CONTROL FOR POWER AND GROUND

1. Turn ignition switch ON.
2. Check voltage between front air control harness connector M49 terminal 8 and terminal 7 while placing the HVAC system into self-diagnostic mode.

Connector	Terminals		Condition	Voltage (Approx.)
	(+)	(-)		
front air control: M49	8	7	Self-diagnostic mode	Battery voltage

Is the inspection result normal?

- OK >> GO TO 4.
- NO >> GO TO 3.

### 2.CHECK INTAKE DOOR MOTOR CIRCUITS FOR SHORT TO GROUND

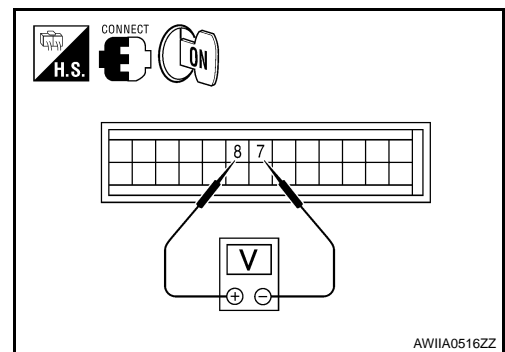

# INTAKE DOOR MOTOR

## < COMPONENT DIAGNOSIS >

[MANUAL A/C (TYPE 3)]

1. Turn ignition switch OFF.
2. Disconnect the front air control harness connector.
3. Check continuity between front air control harness connector M49 terminal 8, 7 and ground.

**8 - Ground : Continuity should not exist.**

**7 - Ground : Continuity should not exist.**

Is the inspection result normal?

OK >> Replace front air control. Refer to [VTL-8, "Removal and Installation"](#).

NO >> Repair or replace harness as necessary.

### 3. CHECK FRONT AIR CONTROL FOR GROUND AND POWER

1. Press the BACK button to back out of self-diagnostic mode.
2. Check voltage between front air control harness connector M49 terminal 8 and terminal 7 while placing the HVAC system into self-diagnostic mode.

Connector	Terminals		Condition	Voltage (Approx.)
	(+)	(-)		
front air control: M49	7	8	Self-diagnostic mode	Battery voltage

Is the inspection result normal?

OK >> GO TO 5.

NO >> Replace front air control. Refer to [VTL-8, "Removal and Installation"](#).

### 4. CHECK INTAKE DOOR MOTOR AND CIRCUITS FOR OPEN

1. Turn ignition switch OFF.
2. Disconnect the front air control harness connector.
3. Check continuity between front air control harness connector M49 terminal 8 and terminal 7.

**Continuity should exist.**

Is the inspection result normal?

OK >> Replace intake door motor. Refer to [VTL-11, "Removal and Installation"](#).

NO >> GO TO 6.

### 5. CHECK INTAKE DOOR MOTOR CIRCUITS FOR OPEN

1. Disconnect the intake door motor harness connector.
2. Check continuity between front air control harness connector M49 (A) terminal 7, 8 and the intake door motor harness connector M58 (B) terminal 1, 6.

**8 - 6 : Continuity should exist.**

**7 - 1 : Continuity should exist.**

Is the inspection result normal?

YES >> Replace intake door motor. Refer to [VTL-11, "Removal and Installation"](#).

NO >> Repair or replace harness as necessary.

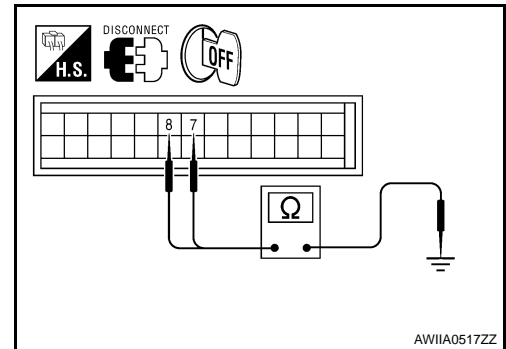

AWIIA0517ZZ

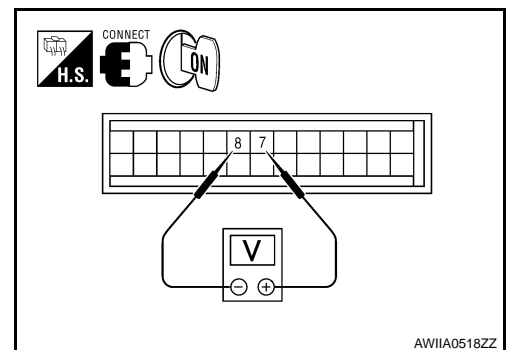

AWIIA0518ZZ

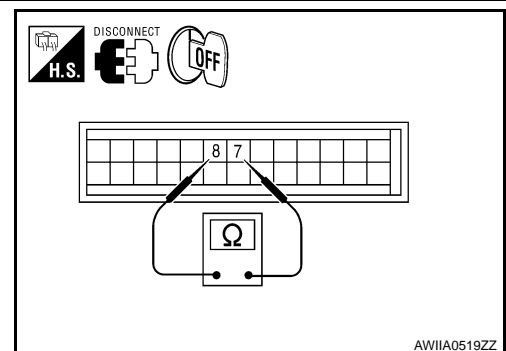

AWIIA0519ZZ

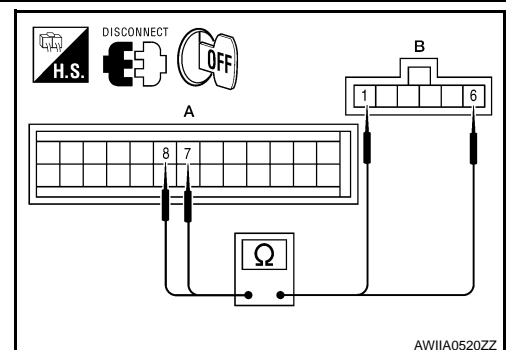

AWIIA0520ZZ

# DEFROSTER DOOR MOTOR CIRCUIT

< COMPONENT DIAGNOSIS >

[MANUAL A/C (TYPE 3)]

## DEFROSTER DOOR MOTOR CIRCUIT

### System Description

INFOID:000000001680535

### SYSTEM DESCRIPTION

#### Component Parts

Defroster door control system components are:

- Front air control
- Defroster door motor
- PBR (Built into defroster door motor)
- Intake sensor

#### System Operation

The front air control determines defroster door position based on the position of the defroster switch. When the defroster switch is depressed, the defroster door motor rotates directing air to the defroster ducts. When any mode other than defroster is selected, the defroster motor rotates in the opposite direction closing off air flow to the defroster ducts.

### COMPONENT DESCRIPTION

#### Defroster door motor

The defroster door motor is attached to the front heater & cooling unit assembly. The front air control sends a voltage to rotate to the defroster door directing the air flow either to the defroster ducts, or to the floor ducts, depending on which way the voltage and ground are applied to the motor leads. Motor rotation is conveyed to a lever which activates the defroster door.

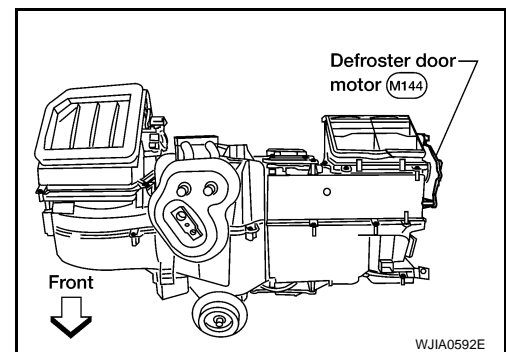

### Defroster Door Motor Component Function Check

INFOID:000000001680536

### INSPECTION FLOW

#### 1. CONFIRM SYMPTOM BY PERFORMING OPERATIONAL CHECK - DEFROSTER DOOR

1. Select vent (☹) mode.
2. Rotate mode control dial to defrost mode (☹☹).
3. Listen for defroster door position change (blower sound should change slightly).

#### Can the symptom be duplicated?

- YES >> GO TO 3.  
NO >> GO TO 2.

#### 2. CHECK FOR ANY SYMPTOMS

Perform a complete operational check for any symptoms. Refer to [HAC-260, "Operational Check"](#).

#### Does another symptom exist?

- YES >> Refer to [HAC-259, "How to Perform Trouble Diagnosis For Quick And Accurate Repair"](#).  
NO >> SYSTEM OK.

#### 3. CHECK FOR SERVICE BULLETINS

Check for any service bulletins.

>> GO TO 4.

#### 4. CHECK DEFROSTER DOOR MOTOR

# DEFROSTER DOOR MOTOR CIRCUIT

< COMPONENT DIAGNOSIS >

[MANUAL A/C (TYPE 3)]

Perform diagnostic procedure for defroster door motor. Refer to [HAC-287, "Defroster Door Motor Component Function Check"](#).

Is the inspection result normal?

YES >> GO TO 5.

NO >> Repair PBR circuit or replace defroster door motor. Refer to [VTL-17, "Removal and Installation"](#).

## 5.CHECK DEFROSTER DOOR OPERATION

Check and verify defroster door mechanism for smooth operation.

Is the inspection result normal?

YES >> Replace defroster door motor. Refer to [VTL-17, "Removal and Installation"](#).

NO >> Repair defroster door mechanism.

## Defroster Door Motor Diagnosis Procedure

INFOID:000000001680537

SYMPTOM:

- Defroster door does not change.
- Defroster door motor does not operate normally.

## DIAGNOSTIC PROCEDURE FOR DEFROSTER DOOR MOTOR

### 1.CHECK FRONT AIR CONTROL FOR POWER AND GROUND

1. Turn ignition switch ON.
2. Rotate the mode control dial to defrost mode (☸).
3. Check voltage between front air control harness connector M49 terminal 20 and terminal 19 and then press the defroster switch (☸) again.

Connector	Terminals		Condition	Voltage (Approx.)
	(+)	(-)		
Front air control: M49	20	19	Press defroster switch	Battery voltage

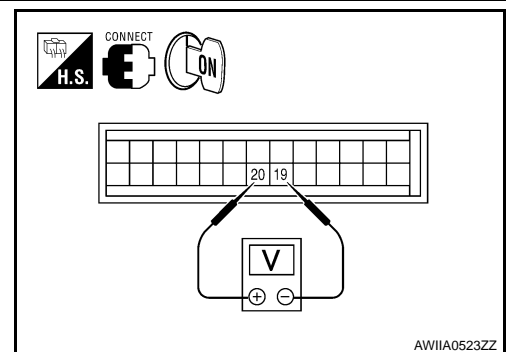

Is the inspection result normal?

YES >> GO TO 4.

NO >> GO TO 3.

### 2.CHECK DEFROSTER DOOR MOTOR CIRCUITS FOR SHORT TO GROUND

1. Turn ignition switch OFF.
2. Disconnect the front air control harness connector.
3. Check continuity between front air control harness connector M49 terminal 19, 20 and ground.

**19 - Ground : Continuity should not exist.**

**20 - Ground : Continuity should not exist.**

Is the inspection result normal?

YES >> Replace front air control. Refer to [VTL-8, "Removal and Installation"](#)

NO >> Repair or replace harness as necessary.

### 3.CHECK FRONT AIR CONTROL FOR GROUND AND POWER

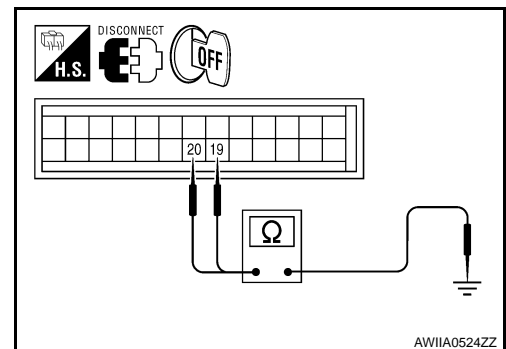





# DEFROSTER DOOR MOTOR CIRCUIT

## < COMPONENT DIAGNOSIS >

[MANUAL A/C (TYPE 3)]

1. Press the defroster switch (  ).
2. Check voltage between front air control harness connector M49 terminal 19 and terminal 20 and the press the defroster switch (  ) again.

Connector	Terminals		Condition	Voltage (Approx.)
	(+)	(-)		
Front air control: M49	19	20	Press defroster switch	Battery voltage

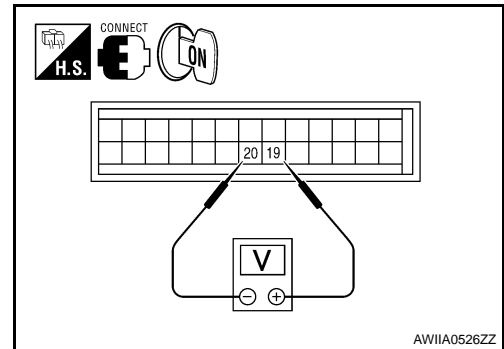

Is the inspection result normal?

YES >> GO TO 5.

NO >> Replace front air control. Refer to [VTL-8. "Removal and Installation"](#).

### 4. CHECK DEFROSTER DOOR MOTOR AND CIRCUITS FOR OPEN

1. Turn ignition switch OFF.
2. Disconnect the front air control harness connector.
3. Check continuity between front air control harness connector M49 terminal 19 and terminal 20.

**Continuity should exist.**

Is the inspection result normal?

YES >> GO TO 7.

NO >> GO TO 6.

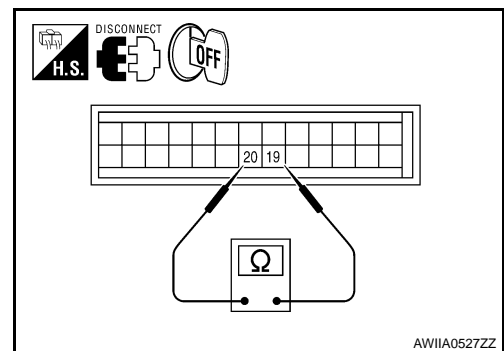

### 5. CHECK DEFROSTER DOOR MOTOR CIRCUITS FOR OPEN

1. Disconnect the defroster door motor harness connector.
2. Check continuity between front air control harness connector M49 terminal 19, 20 and the defroster door motor harness connector M144 terminal 1, 6.

**19 - 1 : Continuity should exist.**

**20 - 6 : Continuity should exist.**

Is the inspection result normal?

YES >> Replace defroster door motor. Refer to [VTL-17. "Removal and Installation"](#).

NO >> Repair or replace harness as necessary.

### 6. CHECK FRONT AIR CONTROL FOR PBR POWER AND GROUND

1. Reconnect front air control harness connector.
2. Turn ignition switch ON.
3. Check voltage between front air control harness connector M49 terminal 2 and 15.

Connector	Terminals		Voltage (Approx.)
	(+)	(-)	
Front air control: M50, M49	2	15	5V

Is the inspection result normal?

YES >> GO TO 9.

NO >> GO TO 8.

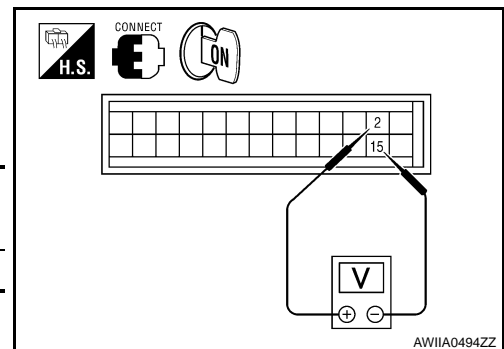

### 7. CHECK PBR REFERENCE VOLTAGE CIRCUIT FOR SHORT TO GROUND

# DEFROSTER DOOR MOTOR CIRCUIT

[MANUAL A/C (TYPE 3)]

## < COMPONENT DIAGNOSIS >

1. Turn ignition switch OFF.
2. Disconnect the front air control harness connector.
3. Check continuity between front air control harness connector M49 terminal 2 and ground.

**Continuity should not exist.**

Is the inspection result normal?

- YES >> Replace front air control. Refer to [VTL-8, "Removal and Installation"](#).
- NO >> Repair or replace harness as necessary.

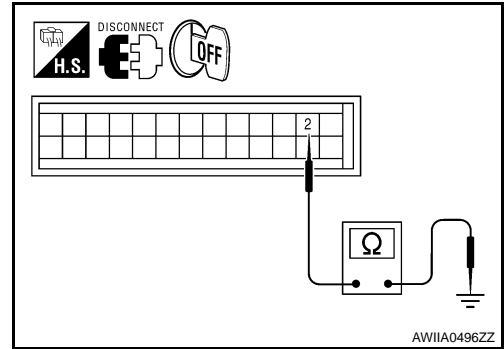

## 8. CHECK PBR REFERENCE VOLTAGE AND GROUND CIRCUITS

1. Turn ignition switch OFF.
2. Disconnect the front air control harness connector.
3. Check continuity between front air control harness connector M49 terminal 2 and 15.

**Continuity should exist.**

Is the inspection result normal?

- YES >> GO TO 11.
- NO >> GO TO 10.

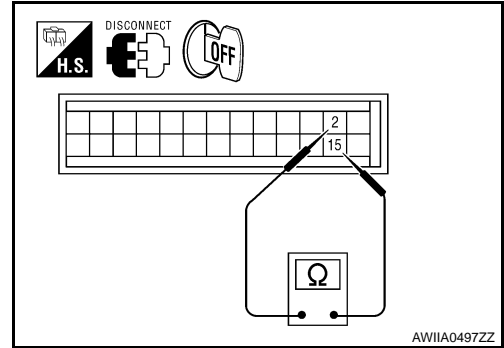

## 9. CHECK PBR REFERENCE VOLTAGE CIRCUIT FOR OPEN

1. Disconnect the defroster door motor harness connector.
2. Check continuity between defroster door motor harness connector M144 (B) terminal 3, 2 and front air control harness connector M49 (A) terminal 2, and 15.

**2 - 3 : Continuity should exist.**

**15 - 2 : Continuity should exist.**

Is the inspection result normal?

- YES >> Replace defroster door motor. Refer to [VTL-17, "Removal and Installation"](#).
- NO >> Repair or replace harness as necessary.

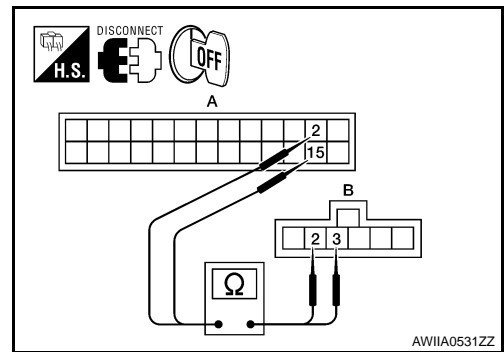

## 10. CHECK PBR FEEDBACK VOLTAGE

1. Reconnect the front air control harness connector.
2. Turn ignition switch ON.
3. Check voltage between front air control harness connector M49 terminal 25 and ground while cycling defroster switch on and off.

**Voltage : Approx. 1V - 4.5V**

Is the inspection result normal?

- YES >> GO TO 13.
- NO >> GO TO 12.

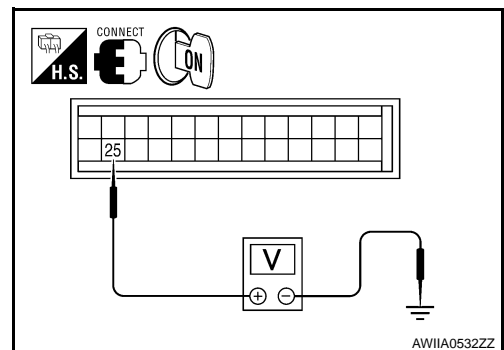

## 11. CHECK PBR FEEDBACK SIGNAL CIRCUIT FOR SHORT TO GROUND

# DEFROSTER DOOR MOTOR CIRCUIT

[MANUAL A/C (TYPE 3)]

## < COMPONENT DIAGNOSIS >

1. Turn ignition switch OFF.
2. Disconnect front air control harness connector.
3. Check continuity between front air control harness connector M49 terminal 25 and ground.

**Continuity should not exist.**

Is the inspection result normal?

- YES >> Replace front air control. Refer to [VTL-8, "Removal and Installation"](#).
- NO >> Repair or replace harness as necessary.

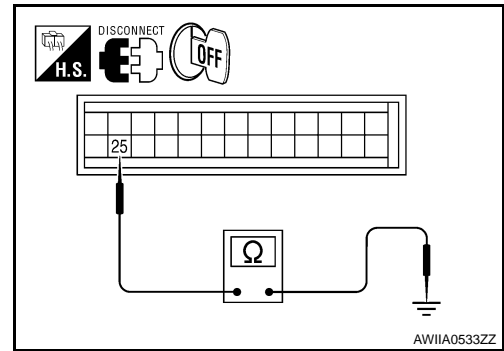

## 12. CHECK PBR FEEDBACK CIRCUIT FOR OPEN

1. Turn ignition switch OFF.
2. Disconnect the defroster door motor harness connector and front air control harness connector.
3. Check continuity between defroster door motor harness connector M144 (B) terminal 4 and front air control harness connector M49 (A) terminal 25

**Continuity should exist.**

Is the inspection result normal?

- YES >> Replace defroster door motor. Refer to [VTL-17, "Removal and Installation"](#).
- NO >> Repair or replace harness as necessary.

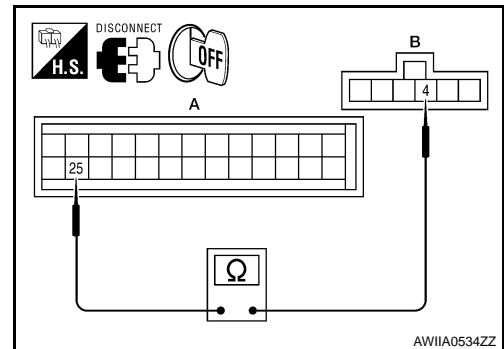

A  
B  
C  
D  
E  
F  
G  
H  
J  
K  
L  
M  
N  
O  
P

HAC



# BLOWER MOTOR CONTROL SYSTEM

< COMPONENT DIAGNOSIS >

[MANUAL A/C (TYPE 3)]

## 2. CHECK FOR ANY SYMPTOMS

Perform a complete operational check for any symptoms. Refer to [HAC-260, "Operational Check"](#).

Does another symptom exist?

YES >> Refer to [HAC-259, "How to Perform Trouble Diagnosis For Quick And Accurate Repair"](#).

NO >> System OK.

## 3. CHECK FOR SERVICE BULLETINS

Check for any service bulletins.

>> GO TO 4.

## 4. CHECK BLOWER MOTOR OPERATION

Check and verify blower motor operates manually in all speeds.

Does blower motor operate in all speeds?

YES >> GO TO 5.

NO >> Refer to [HAC-293, "Front Blower Motor Diagnosis Procedure"](#).

## 5. CHECK ENGINE COOLANT TEMPERATURE SENSOR CIRCUIT

Check engine coolant temperature sensor circuit. Refer to [EC-125, "Diagnosis Procedure"](#).

Is the inspection results normal?

YES >> GO TO 6.

NO >> Replace engine coolant temperature sensor.

## 6. RECHECK FOR ANY SYMPTOMS

Perform a complete operational check for any symptoms. Refer to [HAC-260, "Operational Check"](#).

Does another symptom exist?

YES >> Refer to [HAC-259, "How to Perform Trouble Diagnosis For Quick And Accurate Repair"](#).

NO >> Replace front air control. Refer to [VTL-8, "Removal and Installation"](#).

## Front Blower Motor Diagnosis Procedure

INFOID:000000001680540

SYMPTOM: Blower motor operation is malfunctioning.

### DIAGNOSTIC PROCEDURE FOR BLOWER MOTOR

SYMPTOM: Blower motor operation is malfunctioning under starting blower speed control.

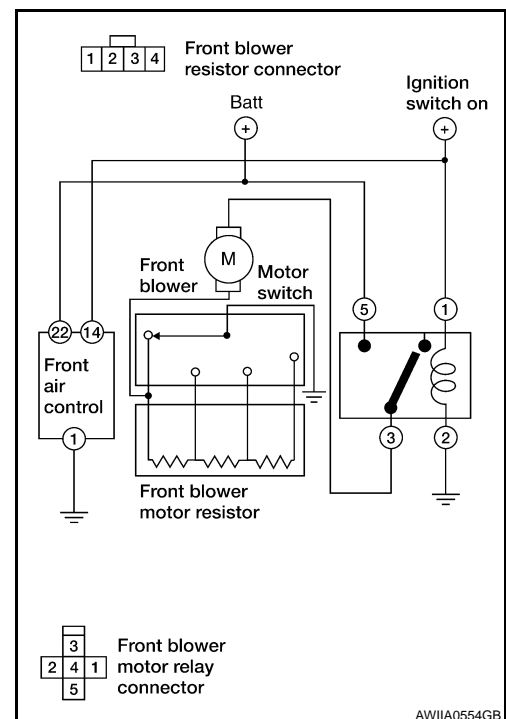

# BLOWER MOTOR CONTROL SYSTEM

< COMPONENT DIAGNOSIS >

[MANUAL A/C (TYPE 3)]

## 1. CHECK FRONT BLOWER MOTOR OPERATION

1. Turn ignition switch ON.
2. Turn blower control dial to each of the four speeds.

Does the blower motor operate normally at each speed?

- YES >> Inspection End..
- NO >> 1. Blower motor does not operate at any speed, GO TO 2.  
2. Blower motor does not operate at 1 - 3 speeds, GO TO 11.  
3. Blower motor does not operate at 4 speed, GO TO 12.

## 2. CHECK FUSES

Check 20A fuses [No. 24 and 27 (Located in the fuse and fusible link box)]. For fuse layout. Refer to [PG-66](#), "[Terminal Arrangement](#)".

**Fuses are good.**

Is the inspection result normal?

- YES >> GO TO 3.  
NO >> GO TO 8.

## 3. CHECK FRONT BLOWER MOTOR POWER SUPPLY CIRCUIT

1. Turn ignition switch OFF.
2. Disconnect front blower motor connector.
3. Turn ignition switch ON.
4. Press the A/C switch.
5. Rotate blower control dial to maximum speed.
6. Check voltage between front blower motor harness connector M62 terminal 2 and ground.

**2 - Ground : Battery voltage**

Is the inspection result normal?

- YES >> GO TO 11.  
NO >> GO TO 4.

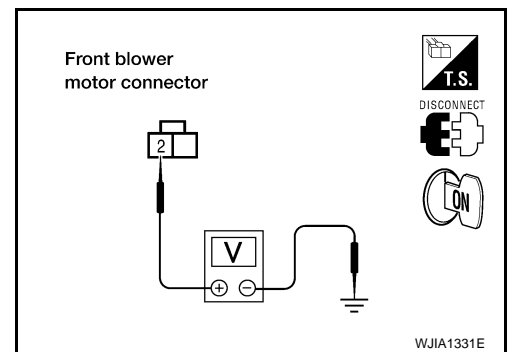

## 4. CHECK FRONT BLOWER MOTOR RELAY

Turn ignition switch OFF.

Check front blower motor relay. Refer to [HAC-296](#), "[Front Blower Motor Component Inspection](#)".

Is the inspection result normal?

- YES >> GO TO 5.  
NO >> Replace front blower motor relay.

## 5. CHECK FRONT BLOWER MOTOR RELAY (SWITCH SIDE) POWER SUPPLY CIRCUIT

1. Turn ignition switch OFF.
2. Check voltage between front blower motor relay harness connector M107 terminal 5 and ground.

**5 - Ground : Battery voltage**

Is the inspection result normal?

- YES >> GO TO 6.  
NO >> Repair harness or connector.

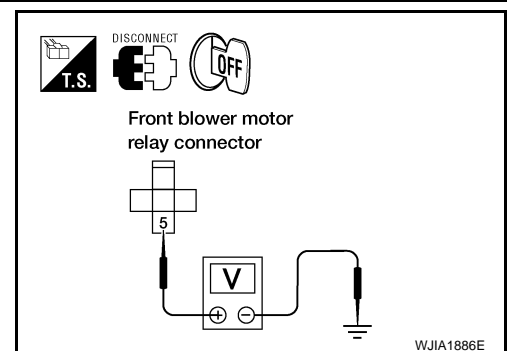

## 6. CHECK FRONT BLOWER MOTOR RELAY (SWITCH SIDE) CIRCUIT FOR OPEN

# BLOWER MOTOR CONTROL SYSTEM

## < COMPONENT DIAGNOSIS >

[MANUAL A/C (TYPE 3)]

Check continuity between front blower motor relay harness connector M107 terminal 3 and front blower motor harness connector M62 terminal 2.

**3 - 2 : Continuity should exist.**

Is the inspection result normal?

- YES >> GO TO 7.
- NO >> Repair harness or connector.

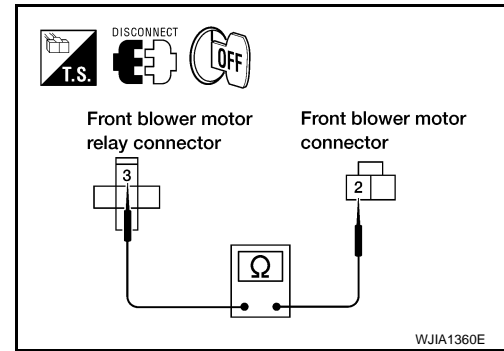

## 7. CHECK FRONT BLOWER MOTOR RELAY (COIL SIDE) POWER SUPPLY

1. Turn ignition switch ON.
2. Check voltage between front blower motor relay harness connector M107 terminal 1 and ground.

**1 - Ground : Battery voltage**

Is the inspection result normal?

- YES >> Repair front blower motor ground circuit or connector.
- NO >> Repair harness or connector.

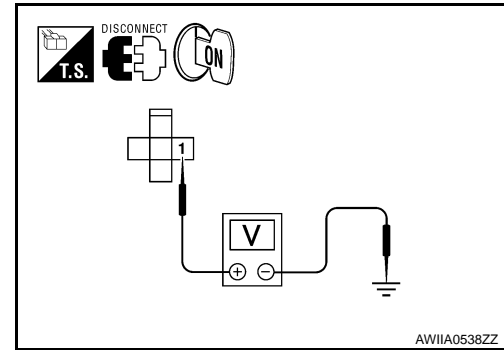

## 8. REPLACE FUSES

1. Replace fuses.
2. Activate the front blower motor.

Does the fuse blow?

- YES >> GO TO 9.
- NO >> Inspection End.

## 9. CHECK FRONT BLOWER MOTOR POWER SUPPLY CIRCUIT FOR SHORT

1. Turn ignition switch OFF.
2. Check continuity between variable blower control harness connector M62 terminal 2 and ground.

**2 - Ground : Continuity should not exist.**

Is the inspection result normal?

- YES >> GO TO 10.
- NO >> Repair harness or connector.

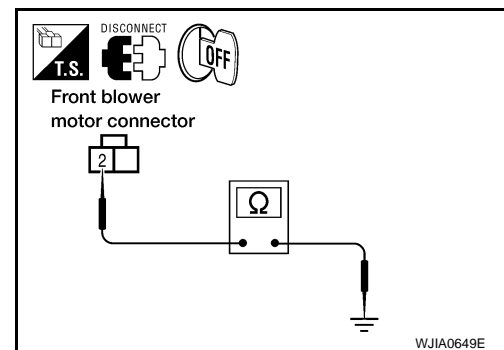

## 10. CHECK FRONT BLOWER MOTOR

Check front blower motor. Refer to [HAC-296, "Front Blower Motor Component Inspection"](#).

Is the inspection result normal?

- YES >> Repair front blower motor relay (switch side) circuit for short.
- NO >> Replace front blower motor. Refer to [VTL-12, "Removal and Installation"](#).

## 11. CHECK BLOWER MOTOR RESISTOR

Check blower motor resistor. Refer to [HAC-296, "Front Blower Motor Component Inspection"](#).

Is the inspection result normal?

- YES >> GO TO 12.
- NO >> Replace blower motor resistor. Refer to [VTL-23, "Removal and Installation"](#).

## 12. CHECK FRONT BLOWER MOTOR SWITCH

# BLOWER MOTOR CONTROL SYSTEM

[MANUAL A/C (TYPE 3)]

## < COMPONENT DIAGNOSIS >

Check front blower motor switch. Refer to [HAC-296. "Front Blower Motor Component Inspection"](#).

Is the inspection result normal?

YES >> GO TO 13.

NO >> Replace blower motor motor switch. Refer to [VTL-8. "Removal and Installation"](#).

### 13. CHECK FRONT BLOWER MOTOR SWITCH CIRCUITS

1. Reconnect blower motor resistor.
2. Disconnect front air control connector.
3. Turn ignition switch ON.
4. Check voltage between front air control harness connector M49 (A) terminal 26, M50 (B) terminals 36, 43, and 44 and ground.

**26 - Ground : Battery voltage**

**36 - Ground : Battery voltage**

**43 - Ground : Battery voltage**

**44 - Ground : Battery voltage**

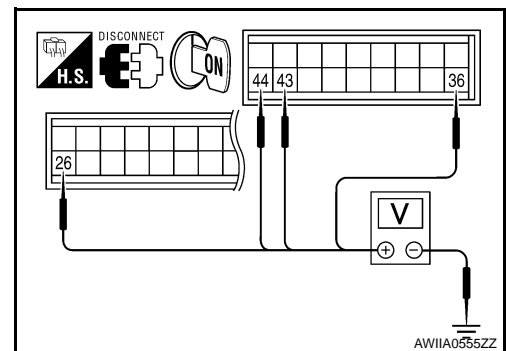

Is the inspection result normal?

YES >> GO TO 14.

NO >> Repair harness or connector.

### 14. CHECK BLOWER MOTOR GROUND CIRCUIT

1. Turn ignition switch OFF.
2. Turn blower control dial OFF.
3. Check continuity between front air control harness connector M50 terminal 41 and ground.

**41 - Ground : Continuity should exist.**

Is the inspection result normal?

YES >> Replace front air control.

NO >> Repair harness or connector.

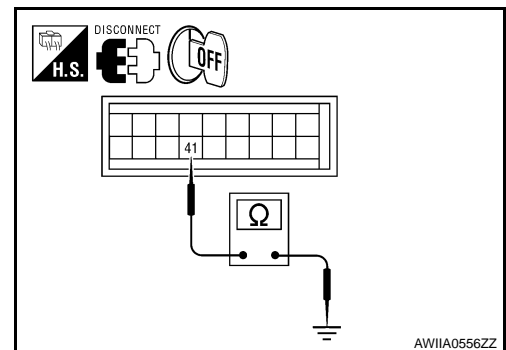

## Front Blower Motor Component Inspection

INFOID:000000001680541

### COMPONENT INSPECTION

Front Blower Motor Relay



# BLOWER MOTOR CONTROL SYSTEM

## < COMPONENT DIAGNOSIS >

[MANUAL A/C (TYPE 3)]

Check continuity between terminals by supplying 12 volts and ground to coil side terminals of relay.

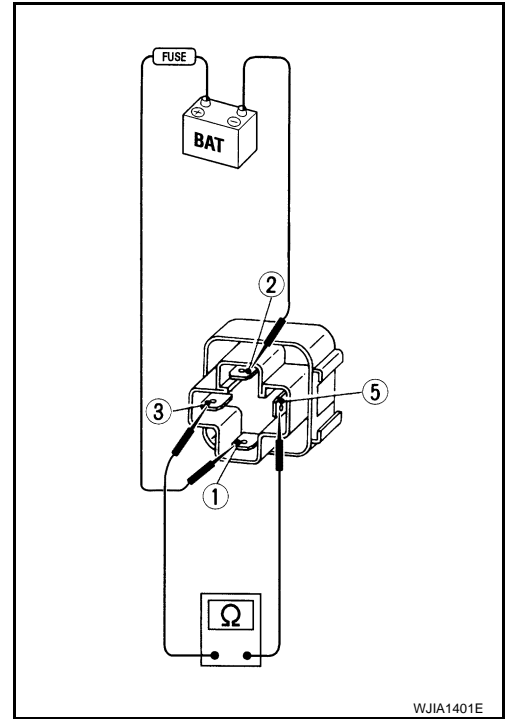

### Front Blower Motor

Confirm smooth rotation of the blower motor.

- Ensure that there are no foreign particles inside the blower unit.
- Apply 12 volts to terminal 2 and ground to terminal 1 and verify that the motor operates freely and quietly.

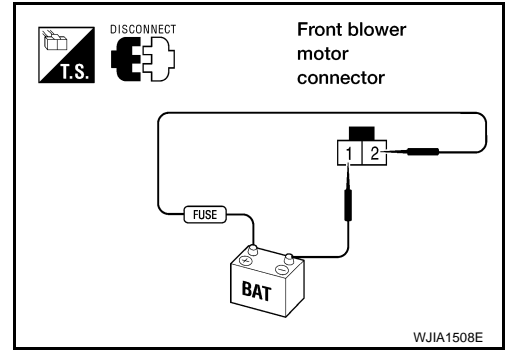

### Front Blower Motor Switch

Check continuity between terminals at each switch position.

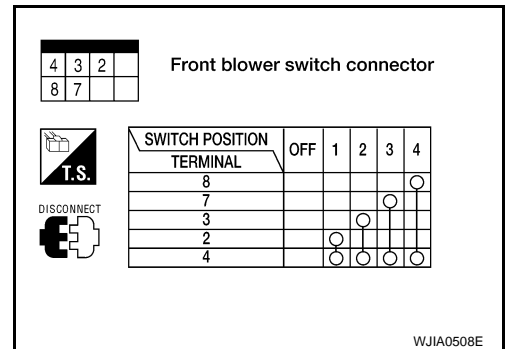

### Front Blower Motor Resistor

A  
B  
C  
D  
E  
F  
G  
H  
HAC  
J  
K  
L  
M  
N  
O  
P

# BLOWER MOTOR CONTROL SYSTEM

## < COMPONENT DIAGNOSIS >

[MANUAL A/C (TYPE 3)]

Check continuity between terminals. There will be resistance, but there should not be an open or short between any two terminals.

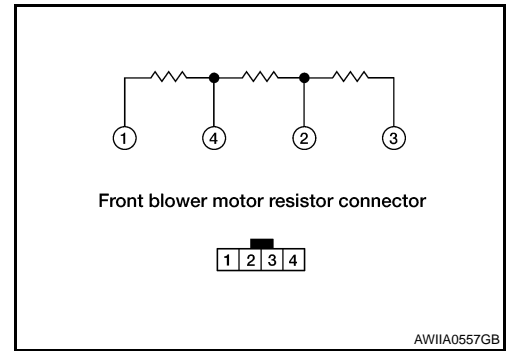

## MAGNET CLUTCH

### System Description

INFOID:000000001680542

### SYSTEM DESCRIPTION

The front air control controls compressor operation based on ambient and intake temperature and a signal from ECM.

#### Low Temperature Protection Control

The front air control will turn the compressor ON or OFF as determined by a signal detected by the intake sensor.

When intake air temperature is higher than the preset value, the compressor turns ON. The compressor turns OFF when intake air temperature is lower than the preset value.

### Magnet Clutch Component Function Check

INFOID:000000001680543

### INSPECTION FLOW

#### 1.CONFIRM SYMPTOM BY PERFORMING OPERATIONAL CHECK - MAGNET CLUTCH

1. Turn ignition switch ON.
2. Turn the blower control dial to low speed and press the A/C switch.
3. Rotate mode control dial to vent mode (↺).
4. Confirm that the compressor clutch engages (sound or visual inspection). (Discharge air and blower speed will depend on ambient, in-vehicle and set temperatures.)

#### Can the symptom be duplicated?

- YES >> GO TO 3.  
NO >> GO TO 2.

#### 2.CHECK FOR ANY SYMPTOMS

Perform a complete operational check for any symptoms. Refer to [HAC-260, "Operational Check"](#).

#### Does another symptom exist?

- YES >> Refer to [HAC-259, "How to Perform Trouble Diagnosis For Quick And Accurate Repair"](#).  
NO >> System OK.

#### 3.CHECK FOR SERVICE BULLETINS

Check for any service bulletins.

>> GO TO 4.

#### 4.CHECK INTAKE SENSOR

Check and verify intake sensor circuit. Refer to [HAC-306, "Intake Sensor Diagnosis Procedure"](#).

>> GO TO 5.

#### 5.RECHECK FOR ANY SYMPTOMS

Perform a complete operational check for any symptoms. Refer to [HAC-260, "Operational Check"](#).

#### Does another symptom exist?

- YES >> Refer to [HAC-259, "How to Perform Trouble Diagnosis For Quick And Accurate Repair"](#).  
NO >> Replace front air control. Refer to [VTL-8, "Removal and Installation"](#).

### Magnet Clutch Diagnosis Procedure

INFOID:000000001680544

### DIAGNOSTIC PROCEDURE FOR MAGNET CLUTCH

A  
B  
C  
D  
E  
F  
G  
H  
HAC  
J  
K  
L  
M  
N  
O  
P

# MAGNET CLUTCH

< COMPONENT DIAGNOSIS >

[MANUAL A/C (TYPE 3)]

SYMPTOM: Magnet clutch does not engage when A/C switch is ON.

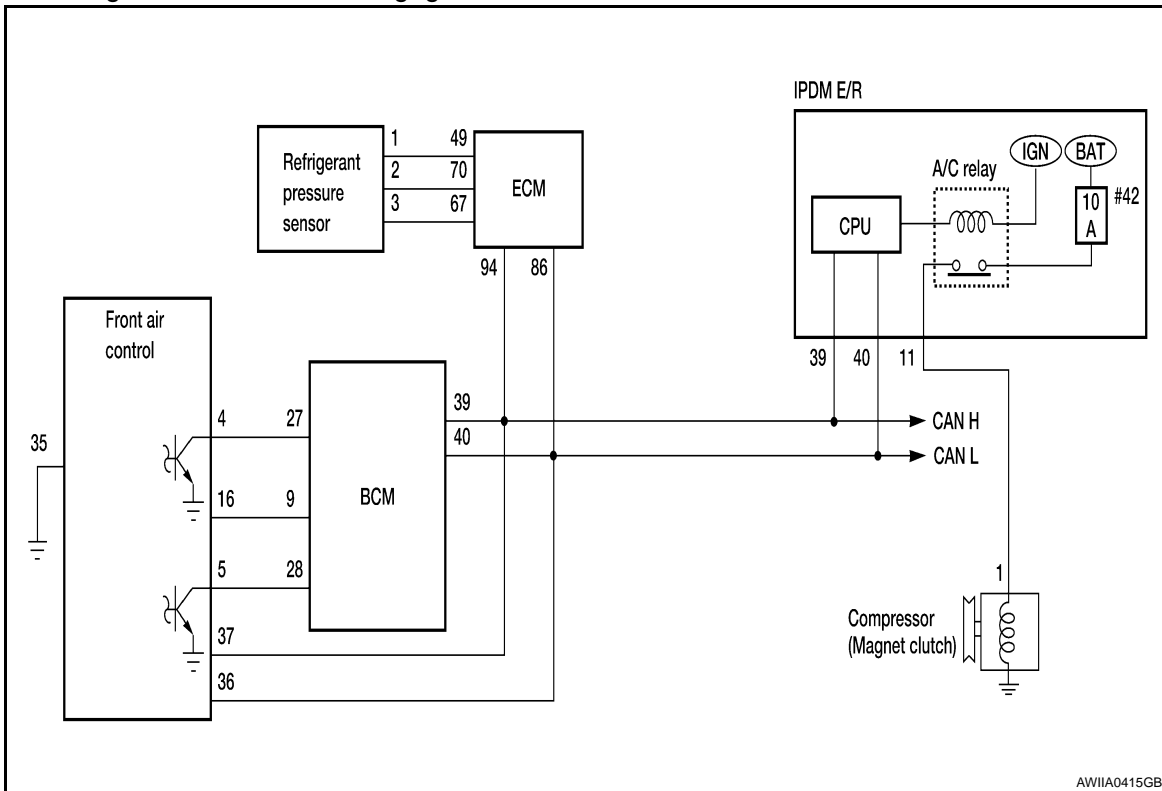

## 1. CHECK INTAKE SENSOR CIRCUIT

Check intake sensors. Refer to [HAC-307, "Intake Sensor Component Inspection"](#).

Is the inspection result normal?

YES >> GO TO 2.

NO >> Check malfunctioning intake sensor. Refer to [HAC-306, "Intake Sensor Diagnosis Procedure"](#).

## 2. PERFORM AUTO ACTIVE TEST

Refer to [PCS-10, "Diagnosis Description"](#).

Does magnet clutch operate?

YES >> •  WITH CONSULT-III  
GO TO 5.

•  WITHOUT CONSULT-III  
GO TO 6.

NO >> Check 10A fuse (No. 42, located in IPDM E/R), and GO TO 3.

## 3. CHECK CIRCUIT CONTINUITY BETWEEN IPDM E/R AND COMPRESSOR

1. Turn ignition switch OFF.
2. Disconnect IPDM E/R connector and compressor (magnet clutch) connector.
3. Check continuity between IPDM E/R harness connector E119 terminal 11 and A/C compressor harness connector F3 terminal 1.

11 - 1

: Continuity should exist.

Is the inspection result normal?

YES >> GO TO 4.

NO >> Repair harness or connector.

## 4. CHECK MAGNET CLUTCH CIRCUIT

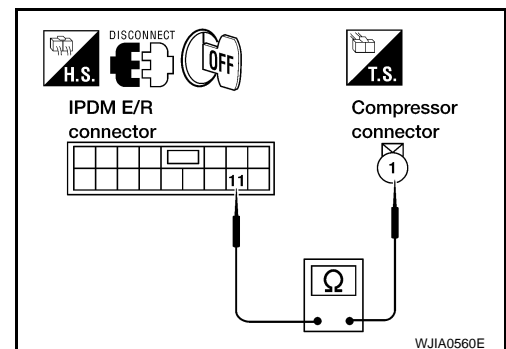

# MAGNET CLUTCH

## < COMPONENT DIAGNOSIS >

[MANUAL A/C (TYPE 3)]

Check for operation sound when applying battery voltage direct current to terminal.

Is the inspection result normal?

- YES >> Replace IPDM E/R. Refer to [PCS-30, "Removal and Installation of IPDM E/R"](#).
- NO >> Replace magnet clutch. Refer to [HA-34, "Removal and Installation for Compressor Clutch"](#).

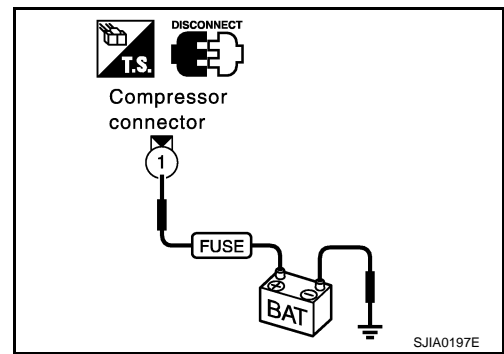

### 5. CHECK BCM INPUT (COMPRESSOR ON) SIGNAL

Check compressor ON/OFF signal. Refer to [HAC-272, "CONSULT-III Function \(BCM\)"](#).

**A/C SW ON : COMP ON SIG ON**  
**A/C SW OFF : COMP ON SIG OFF**

Is the inspection result normal?

- YES >> GO TO 8.
- NO >> GO TO 6.

### 6. CHECK CIRCUIT CONTINUITY BETWEEN BCM AND FRONT AIR CONTROL

1. Turn ignition switch OFF.
2. Disconnect BCM connector and front air control connector.
3. Check continuity between BCM harness connector M18 (A) terminal 27 and front air control harness connector M49 (B) terminal 12.

**27 - 12 Continuity should exist.**

Is the inspection result normal?

- YES >> GO TO 7.
- NO >> Repair harness or connector.

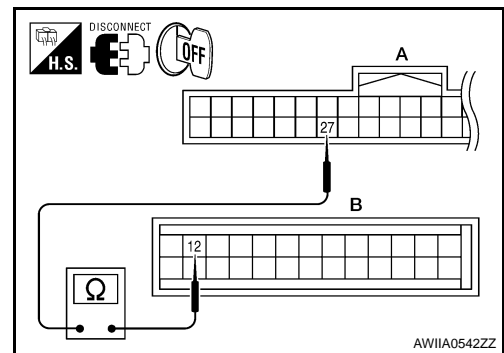

### 7. CHECK VOLTAGE FOR FRONT AIR CONTROL (A/C COMPRESSOR ON SIGNAL)

1. Reconnect BCM connector and front air control connector.
2. Turn ignition switch ON.
3. Check voltage between front air control harness connector M49 terminal 12 and ground.

Terminals		Condition	Voltage
(+)	(-)		
front air control connector	Terminal No.		
M49	12	Ground	A/C switch: ON Approx. 0V
			A/C switch: OFF Approx. 5V

Is the inspection result normal?

- YES >> GO TO 8.
- NO-1 >> If the voltage is approx. 5V when A/C switch is ON, replace front air control. Refer to [VTL-8, "Removal and Installation"](#).
- NO-2 >> If the voltage is approx. 0V when A/C switch is OFF, replace BCM. Refer to [BCS-50, "Removal and Installation"](#).

### 8. CHECK REFRIGERANT PRESSURE SENSOR

1. Start engine.

# MAGNET CLUTCH

## < COMPONENT DIAGNOSIS >

[MANUAL A/C (TYPE 3)]

- Check voltage between ECM harness connector F54 terminal 70 and ground.

Terminals		(-)	Condition	Voltage
(+) Terminal No.				
ECM connector	Terminal No.			
F54	70	Ground	A/C switch: ON	Approx. 0.36 - 3.88V

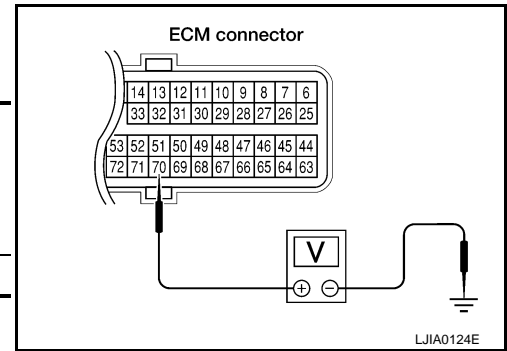

Is the inspection result normal?

- YES >> GO TO 9.  
 NO >> Refer to [EC-412, "Diagnosis Procedure"](#).

## 9. CHECK BCM INPUT (FAN ON) SIGNAL

Check FAN ON/OFF signal. Refer to [HAC-272, "CONSULT-III Function \(BCM\)"](#).

**FRONT BLOWER CONTROL : FAN ON SIG ON  
 DIAL ON**

**FRONT BLOWER CONTROL : FAN ON SIG OFF  
 DIAL OFF**

Is the inspection result normal?

- YES >> GO TO 12.  
 NO >> GO TO 10.

## 10. CHECK CIRCUIT CONTINUITY BETWEEN BCM AND FRONT AIR CONTROL

- Turn ignition switch OFF.
- Disconnect BCM connector and front air control connector.
- Check continuity between BCM harness connector M18 (A) terminal 28 and front air control harness connector M50 terminal 36.

**28 - 36 Continuity should exist.**

Is the inspection result normal?

- YES >> GO TO 11.  
 NO >> Repair harness or connector.

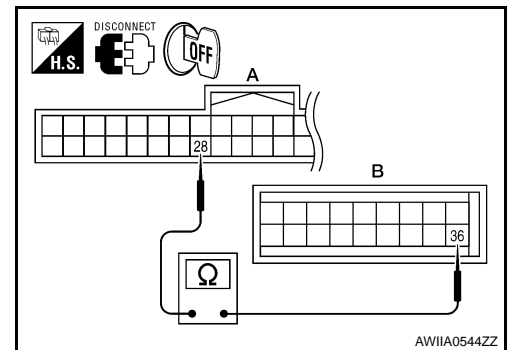

## 11. CHECK VOLTAGE FOR FRONT AIR CONTROL (FAN ON SIGNAL)

- Reconnect BCM connector and front air control connector.
- Turn ignition switch ON.
- Check voltage between front air control harness connector M50 terminal 36 and ground.

Terminals		(-)	Condition	Voltage
(+) Terminal No.				
front air control connector	Terminal No.			
M50	36	Ground	A/C switch: ON Blower motor operates	Approx. 0V
			A/C switch: OFF	Approx. 5V

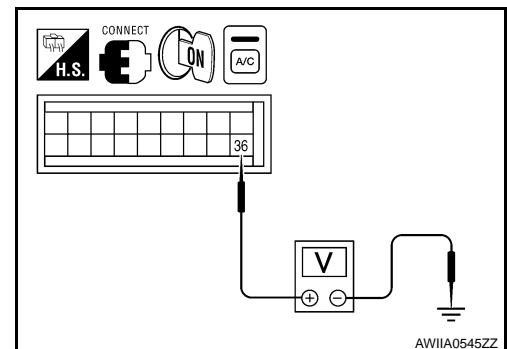

Is the inspection result normal?

- YES >> GO TO 12.  
 NO-1 >> If the voltage is approx. 5V when blower motor is ON, replace front air control. Refer to [VTL-8, "Removal and Installation"](#).

# MAGNET CLUTCH

< COMPONENT DIAGNOSIS >

[MANUAL A/C (TYPE 3)]

NO-2 >> If the voltage is approx. 0V when blower motor is OFF, replace BCM. Refer to [BCS-50. "Removal and Installation"](#).

## 12.CHECK CAN COMMUNICATION

Check CAN communication. Refer to [LAN-4. "System Description"](#).

- BCM – ECM
- ECM – IPDM E/R
- ECM – Front air control

Is the inspection result normal?

YES >> Inspection End.

NO >> Repair or replace malfunctioning part(s).

A  
B  
C  
D  
E  
F  
G  
H  
J  
K  
L  
M  
N  
O  
P

HAC

# WATER VALVE CIRCUIT

< COMPONENT DIAGNOSIS >

[MANUAL A/C (TYPE 3)]

## WATER VALVE CIRCUIT

### Description

INFOID:000000001680545

### COMPONENT DESCRIPTION

#### Water Valve

The water valve (1) cuts the flow of engine coolant to the heater core to allow for maximum cooling during A/C operation. It is controlled by the front air control.

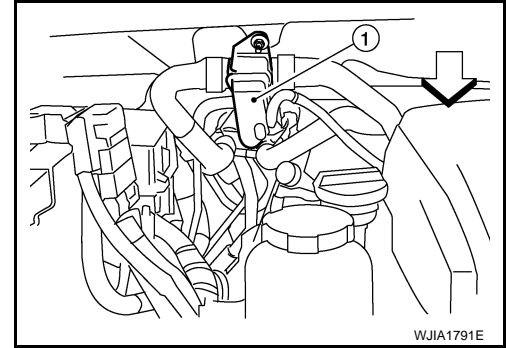

### Water Valve Diagnosis Procedure

INFOID:000000001680546

#### DIAGNOSTIC PROCEDURE FOR WATER VALVE

#### 1. CHECK WATER VALVE POWER AND GROUND CIRCUITS

1. Disconnect water valve connector F68.
2. Turn ignition switch ON.
3. Rotate temperature control dial to maximum heat.
4. Check voltage between water valve harness connector F68 terminal 1 and terminal 2 while rotating temperature control dial to maximum cold.

Connector	Terminals		Condition	Voltage (Approx.)
	(+)	(-)		
Water valve: F68	2	1	Rotate temperature control dial	Battery voltage

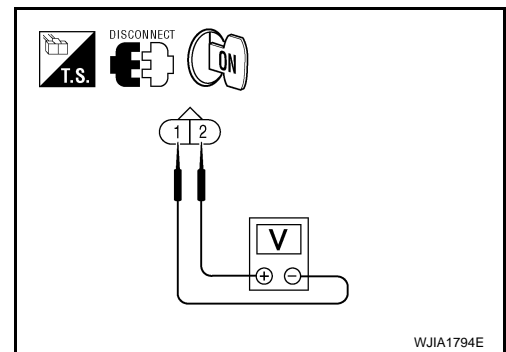

Is the inspection result normal?

- YES >> GO TO 3.  
NO >> GO TO 2.

#### 2. CHECK WATER VALVE CONTROL OUTPUT CIRCUIT

1. Turn ignition switch OFF.
2. Disconnect front air control connector M50.
3. Check continuity between water valve harness connector F68 (A) terminal 2 and front air control harness connector M50 (B) terminal 30.

**2 - 30 : Continuity should exist.**

4. Check continuity between water valve harness connector F68 terminal 2 and ground.

**2 - Ground : Continuity should not exist.**

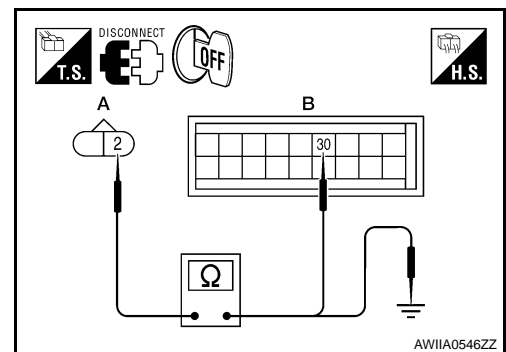

Is the inspection result normal?

- YES >> Replace front air control. Refer to [VTL-8, "Removal and Installation"](#).  
NO >> Repair harness or connector.

#### 3. CHECK WATER VALVE POWER AND GROUND CIRCUITS



# WATER VALVE CIRCUIT

[MANUAL A/C (TYPE 3)]

## < COMPONENT DIAGNOSIS >

1. Rotate temperature control dial to maximum cold.
2. Check voltage between water valve harness connector F68 terminal 1 and terminal 2 while rotating temperature control dial to maximum heat.

Connector	Terminals		Condition	Voltage (Approx.)
	(+)	(-)		
Water valve: F68	1	2	Rotate temperature control dial	Battery voltage

**Is the inspection result normal?**

- YES >> Replace the water valve.  
 NO >> GO TO 4.

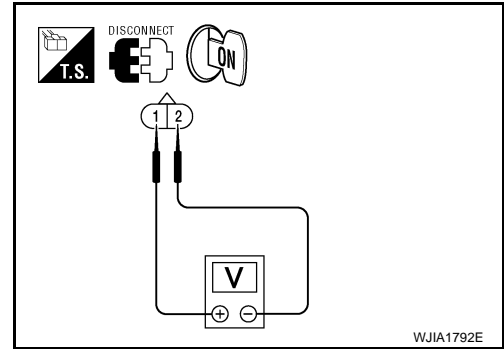

## 4. CHECK WATER VALVE CONTROL OUTPUT CIRCUIT

1. Turn ignition switch OFF.
2. Disconnect front air control connector M50.
3. Check continuity between water valve harness connector F68 (A) terminal 1 and front air control harness connector M50 (B) terminal 29.

**1 - 29 : Continuity should exist.**

4. Check continuity between water valve harness connector F68 (A) terminal 1 and ground.

**1 - Ground : Continuity should not exist.**

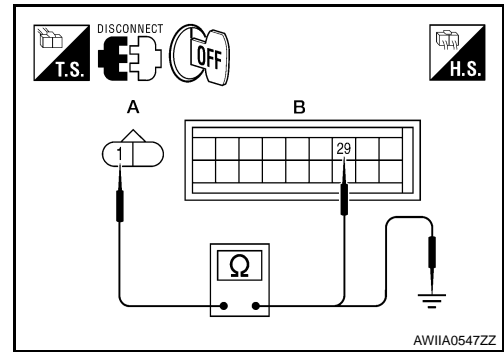

**Is the inspection result normal?**

- YES >> Replace front air control. Refer to [VTL-8, "Removal and Installation"](#).  
 NO >> Repair harness or connector.

A  
B  
C  
D  
E  
F  
G  
H  
J  
K  
L  
M  
N  
O  
P

HAC

# INTAKE SENSOR

< COMPONENT DIAGNOSIS >

[MANUAL A/C (TYPE 3)]

## INTAKE SENSOR

### System Description

INFOID:000000001680550

### COMPONENT DESCRIPTION

#### Intake Sensor

The intake sensor is located on the heater & cooling unit assembly. It converts temperature of air after it passes through the evaporator into a resistance value which is then input to the front air control.

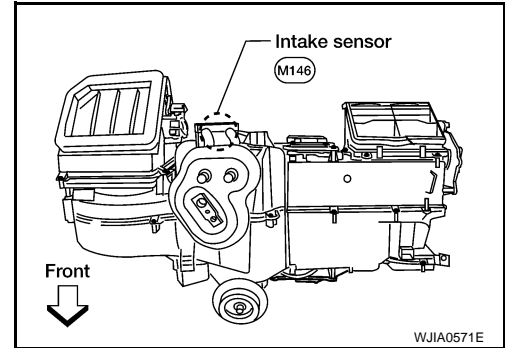

### Intake Sensor Diagnosis Procedure

INFOID:000000001680551

#### DIAGNOSTIC PROCEDURE FOR INTAKE SENSOR

SYMPTOM: Intake sensor circuit is open or shorted.

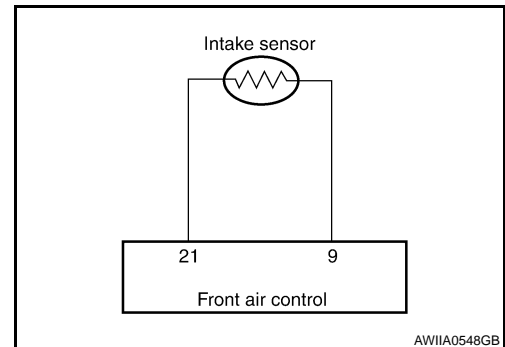

#### 1. CHECK VOLTAGE BETWEEN INTAKE SENSOR AND GROUND

1. Disconnect intake sensor connector.
2. Turn ignition switch ON.
3. Check voltage between intake sensor harness connector M146 terminal 2 and ground.

**2 - Ground : Approx. 5V**

Is the inspection result normal?

- YES >> GO TO 3.  
NO >> GO TO 4.

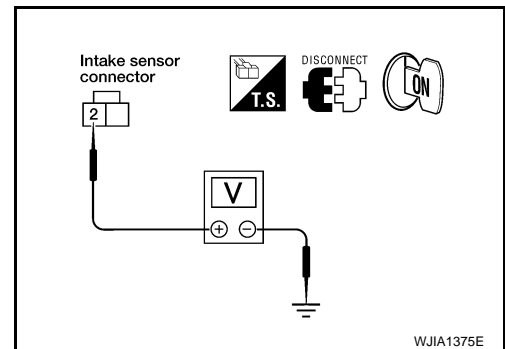

#### 2. CHECK CIRCUIT CONTINUITY BETWEEN INTAKE SENSOR AND FRONT AIR CONTROL

1. Turn ignition switch OFF.
2. Disconnect front air control connector.
3. Check continuity between intake sensor harness connector M146 (B) terminal 1 and front air control harness connector M49 (A) terminal 21.

**1 - 21 : Continuity should exist.**

Is the inspection result normal?

- YES >> GO TO 4.  
NO >> Repair harness or connector.

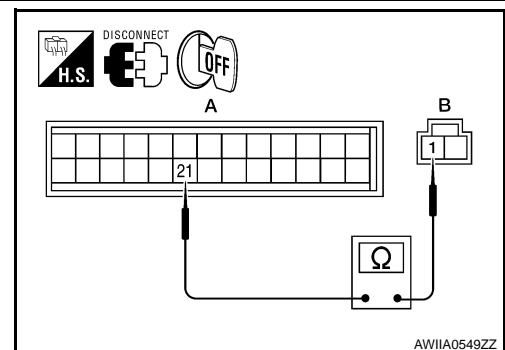

# INTAKE SENSOR

< COMPONENT DIAGNOSIS >

[MANUAL A/C (TYPE 3)]

## 3. CHECK INTAKE SENSOR

Check intake sensor. Refer to [HAC-307. "Intake Sensor Component Inspection"](#).

Is the inspection result normal?

YES >> Replace front air control. Refer to [VTL-8. "Removal and Installation"](#).

NO >> Replace intake sensor. Refer to [VTL-11. "Removal and Installation"](#).

## 4. CHECK CIRCUIT CONTINUITY BETWEEN INTAKE SENSOR AND FRONT AIR CONTROL

1. Turn ignition switch OFF.
2. Disconnect front air control connector.
3. Check continuity between intake sensor harness connector M146 (B) terminal 2 and front air control harness connector M49 (A) terminal 9.

**2 - 9** : Continuity should exist.

4. Check continuity between intake sensor harness connector M146 terminal 6 and ground.

**2 - Ground** : Continuity should not exist.

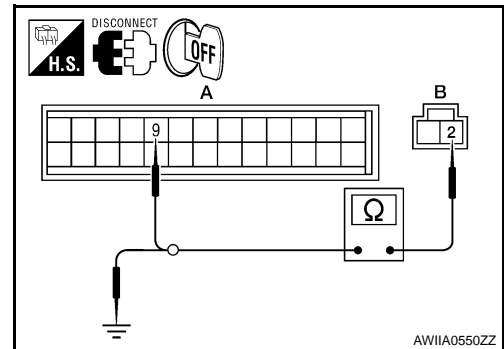

Is the inspection result normal?

YES >> Replace front air control. Refer to [VTL-8. "Removal and Installation"](#).

NO >> Repair harness or connector.

## Intake Sensor Component Inspection

INFOID:000000001680552

### COMPONENT INSPECTION

Intake Sensor

After disconnecting intake sensor connector, measure resistance between terminals 1 and 2 at sensor harness side, using the table below.

Temperature °C (°F)	Resistance kΩ
-15 (5)	209.0
-10 (14)	160.0
-5 (23)	123.0
0 (32)	95.8
5 (41)	74.9
10 (50)	58.9
15 (59)	46.7
20 (68)	37.3
25 (77)	30.0
30 (86)	24.2
35 (95)	19.7
40 (104)	16.1
45 (113)	13.2

If NG, replace intake sensor. Refer to [VTL-11. "Removal and Installation"](#).

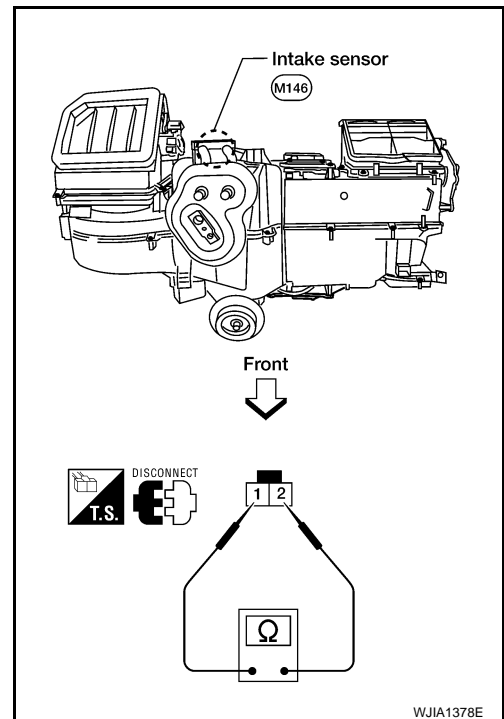

A  
B  
C  
D  
E  
F  
G  
H  
J  
K  
L  
M  
N  
O  
P

HAC

# POWER SUPPLY AND GROUND CIRCUIT FOR CONTROLLER

< COMPONENT DIAGNOSIS >

[MANUAL A/C (TYPE 3)]

## POWER SUPPLY AND GROUND CIRCUIT FOR CONTROLLER

### Component Description

INFOID:000000001680553

#### COMPONENT DESCRIPTION

##### Front Air Control

The front air control has a built-in microcomputer which processes information sent from various sensors needed for air conditioner operation. The air mix door motor, mode door motor, intake door motor, defroster door motor, blower motor and A/C compressor are then controlled.

The front air control is unitized with control mechanisms. When the various switches and temperature dials are operated, data is input to the front air control.

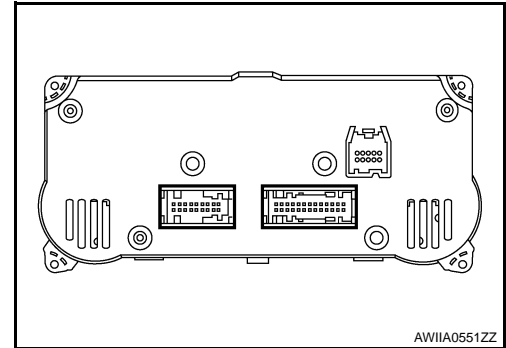

##### Potential Temperature Control (PTC)

The PTC is built into the front air control. It can be set from cold to hot or any intermediate position by rotating the temperature control dial.

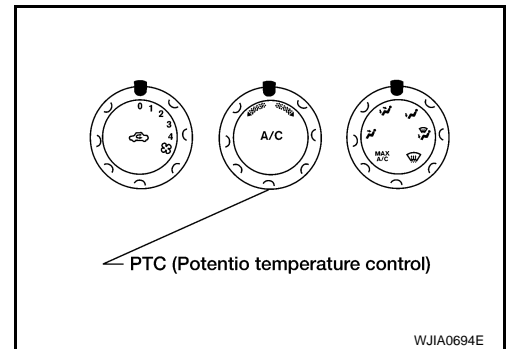

### Front Air Control Component Function Check

INFOID:000000001680554

SYMPTOM: A/C system does not come on.

#### INSPECTION FLOW

##### 1. CONFIRM SYMPTOM BY PERFORMING OPERATIONAL CHECK

1. Turn the blower control dial clockwise to low speed.
2. Press the A/C switch.
3. Confirm that the compressor clutch engages (sound or visual inspection).

Can a symptom be duplicated?

- YES >> GO TO 3.  
NO >> GO TO 2.

##### 2. PERFORM COMPLETE OPERATIONAL CHECK

Perform a complete operational check and check for any symptoms. Refer to [HAC-260, "Operational Check"](#).

Can a symptom be duplicated?

- YES >> Refer to [HAC-259, "How to Perform Trouble Diagnosis For Quick And Accurate Repair"](#).  
NO >> System OK.

##### 3. CHECK FOR SERVICE BULLETINS

Check for any service bulletins.

>> GO TO 4.

##### 4. CHECK POWER AND GROUND CIRCUIT

Check main power supply and ground circuit. Refer to [HAC-309, "Front Air Control Power and Ground Diagnosis Procedure"](#).

# POWER SUPPLY AND GROUND CIRCUIT FOR CONTROLLER

< COMPONENT DIAGNOSIS >

[MANUAL A/C (TYPE 3)]

Is the inspection result normal?

YES >> System OK.

NO >> Replace front air control. Refer to [VTL-8. "Removal and Installation"](#).

## Front Air Control Power and Ground Diagnosis Procedure

INFOID:000000001680555

### DIAGNOSTIC PROCEDURE FOR A/C SYSTEM

SYMPTOM: A/C system does not come on.

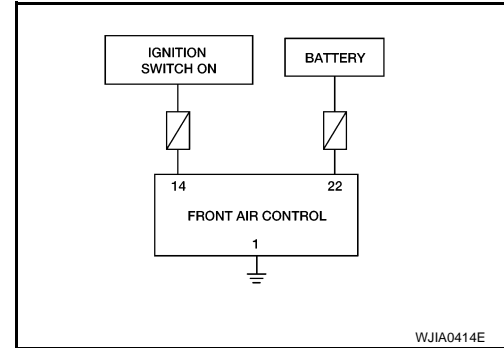

## 1. CHECK POWER SUPPLY CIRCUITS FOR FRONT AIR CONTROL

1. Disconnect front air control connectors.
2. Check voltage between front air control harness connector M49 terminals 14, 22 and ground.

Terminals		Ignition switch position			
(+)		(-)	OFF	ACC	ON
Front air control connector	Terminal No.				
M49	14	Ground	Approx. 0V	Approx. 0V	Battery voltage
M49	22		Battery voltage	Battery voltage	Battery voltage

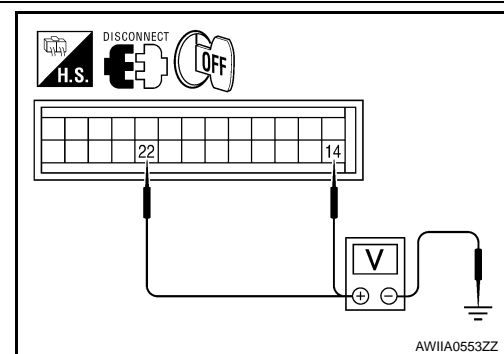

Is the inspection result normal?

YES >> GO TO 3.

NO >> Check 10A fuses [Nos. 8 and 19, located in the fuse block (J/B)]. Refer to [PG-66. "Terminal Arrangement"](#).

- If fuses are OK, check harness for open circuit. Repair or replace as necessary.
- If fuses are NG, replace fuse and check harness for short circuit. Repair or replace as necessary.

## 2. CHECK GROUND CIRCUIT FOR FRONT AIR CONTROL

1. Turn ignition switch OFF.
2. Check continuity between front air control harness connector M49 terminal 1 and ground.

**1 - Ground : Continuity should exist.**

Is the inspection result normal?

OK >> Replace front air control. Refer to [VTL-8. "Removal and Installation"](#).

NG >> Repair harness or connector.

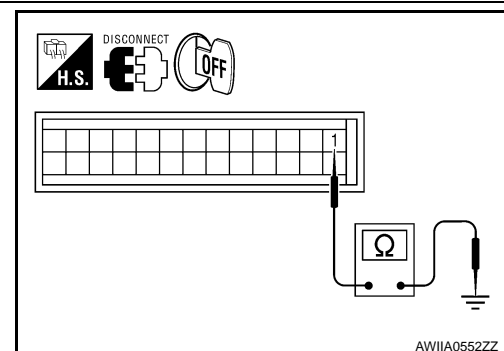

# MANUAL A/C IDENTIFICATION TABLE

< ECU DIAGNOSIS >

[MANUAL A/C (TYPE 3)]

## ECU DIAGNOSIS

### MANUAL A/C IDENTIFICATION TABLE

#### Application Table

INFOID:000000001680587

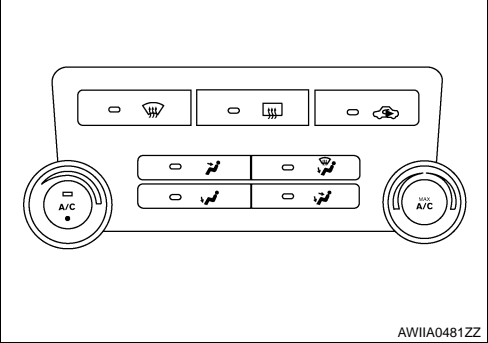
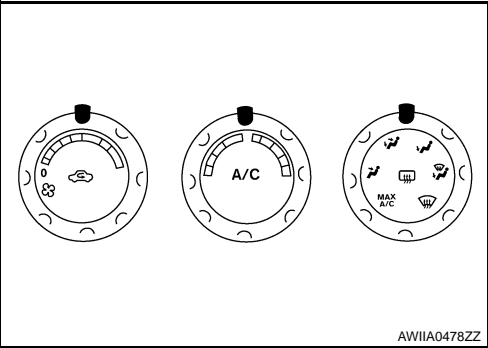
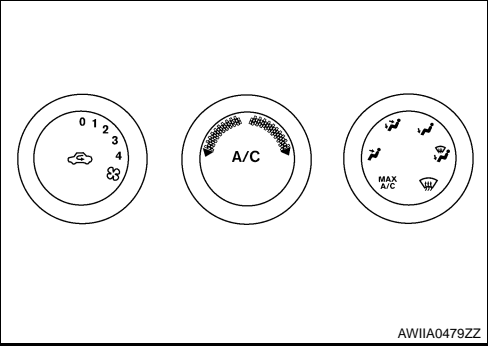
Manual A/C Type	Description	Visual Identification
Manual A/C (Type 1)	Two Control Dial System	
Manual A/C (Type 2)	Three Control Dial System [with variable blower control (VBC)]	
Manual A/C (Type 3)	Three Control Dial System [without variable blower control (VBC)]	

# AIR CONDITIONER CONTROL

< ECU DIAGNOSIS >

[MANUAL A/C (TYPE 3)]

## AIR CONDITIONER CONTROL

### Front Air Control Terminals Reference Values

INFOID:000000001680588

Measure voltage between each terminal and ground by following Terminals and Reference Value for front air control (1).

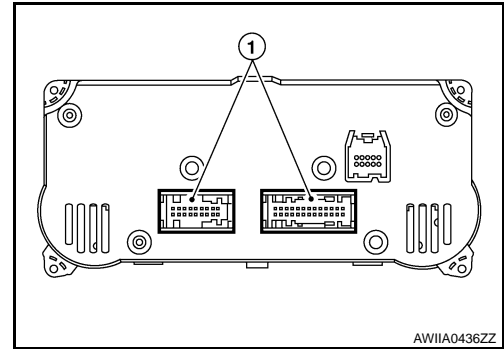

### FRONT AIR CONTROL HARNESS CONNECTOR TERMINAL LAYOUT

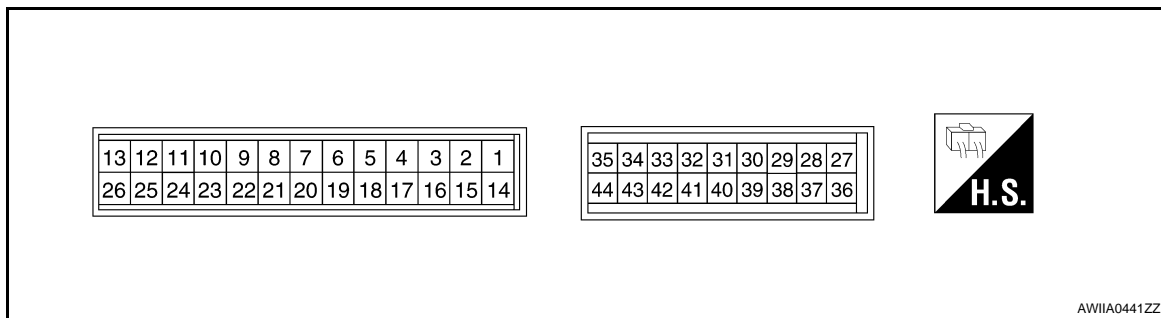

### TERMINALS AND RERERENCE VALUES FOR FRONT AIR CONTROL

Terminal No.	Wire color	Item	Ignition switch	Condition	Voltage (V) (Approx.)
1	B	Ground	-	-	0V
2	Y	V ref ACTR (5V)	ON	-	0 - 5V
3	W/G	Air mix door motor CW	ON	Clockwise rotation	Battery voltage
4	G	Air mix door motor CCW	ON	Counterclockwise rotation	Battery voltage
5	BR/W	Mode door motor CW	ON	Clockwise rotation	Battery voltage
6	P/L	Mode door motor CCW	ON	Counterclockwise rotation	Battery voltage
7	O	Intake door motor CW	ON	Clockwise rotation	Battery voltage
8	G/B	Intake door motor CCW	ON	Counterclockwise rotation	Battery voltage
9	L/B	Intake sensor	ON	-	0 - 5V
11	Y/B	Rear defrost request	ON	-	Battery voltage
12	W/R	Compressor ON signal	ON	A/C switch OFF	5V
			ON	A/C switch ON	0V
14	Y/G	Power supply for IGN	ON	-	Battery voltage
15	P	V ref ACTR (ground)	ON	-	5V
16	GR	Mode door motor feedback	ON	-	0 - 5V
18	SB	Air mix door motor feedback	ON	-	0 - 5V
19	LG	Defroster door motor CW	ON	Clockwise rotation	Battery voltage
20	P/B	Defroster door motor CCW	ON	Counterclockwise rotation	Battery voltage
21	V/R	Sensor ground	ON	-	0V
22	Y/R	Power supply for BAT	-	-	Battery voltage
23	R/L	Illumination +	ON	Park lamps ON	Battery voltage

# AIR CONDITIONER CONTROL

< ECU DIAGNOSIS >

[MANUAL A/C (TYPE 3)]

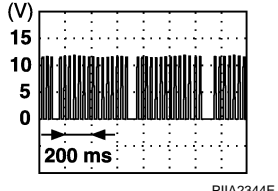
Terminal No.	Wire color	Item	Ignition switch	Condition	Voltage (V) (Approx.)
24	BR	Illumination -	-	Park lamps ON	
25	LG/B	Defroster door motor feedback	ON	-	0 - 5V
26	R/B	Front blower request	ON	Front blower motor OFF	Battery voltage
				Front blower motor ON	0V
29	Y/L	Water valve	ON	Water valve open	Battery voltage
				Water valve closed	0V
30	W/G	Water valve	ON	Water valve open	0V
				Water valve closed	Battery voltage
34	L	CAN-H	ON	-	0 - 5V
35	P	CAN-L	ON	-	0 - 5V
36	L/W	Blower speed input	ON	Front blower motor OFF	Battery voltage
			ON	Front blower motor ON	0V
41	B/W	Blower ground	ON	Front blower motor OFF	Battery voltage
			ON	Front blower motor ON	0V
43	L/R	Blower speed 2	ON	Front blower motor OFF	Battery voltage
			ON	Front blower motor ON	0V
44	L/Y	Blower speed 3	ON	Front blower motor OFF	Battery voltage
			ON	Front blower motor ON	0V



# AIR CONDITIONER CONTROL

< ECU DIAGNOSIS >

[MANUAL A/C (TYPE 3)]

## Wiring Diagram

INFOID:000000001680589

### AIR CONDITIONER CONTROL - MANUAL WITHOUT 3 CONTROL DIAL SYSTEM WITHOUT VBC

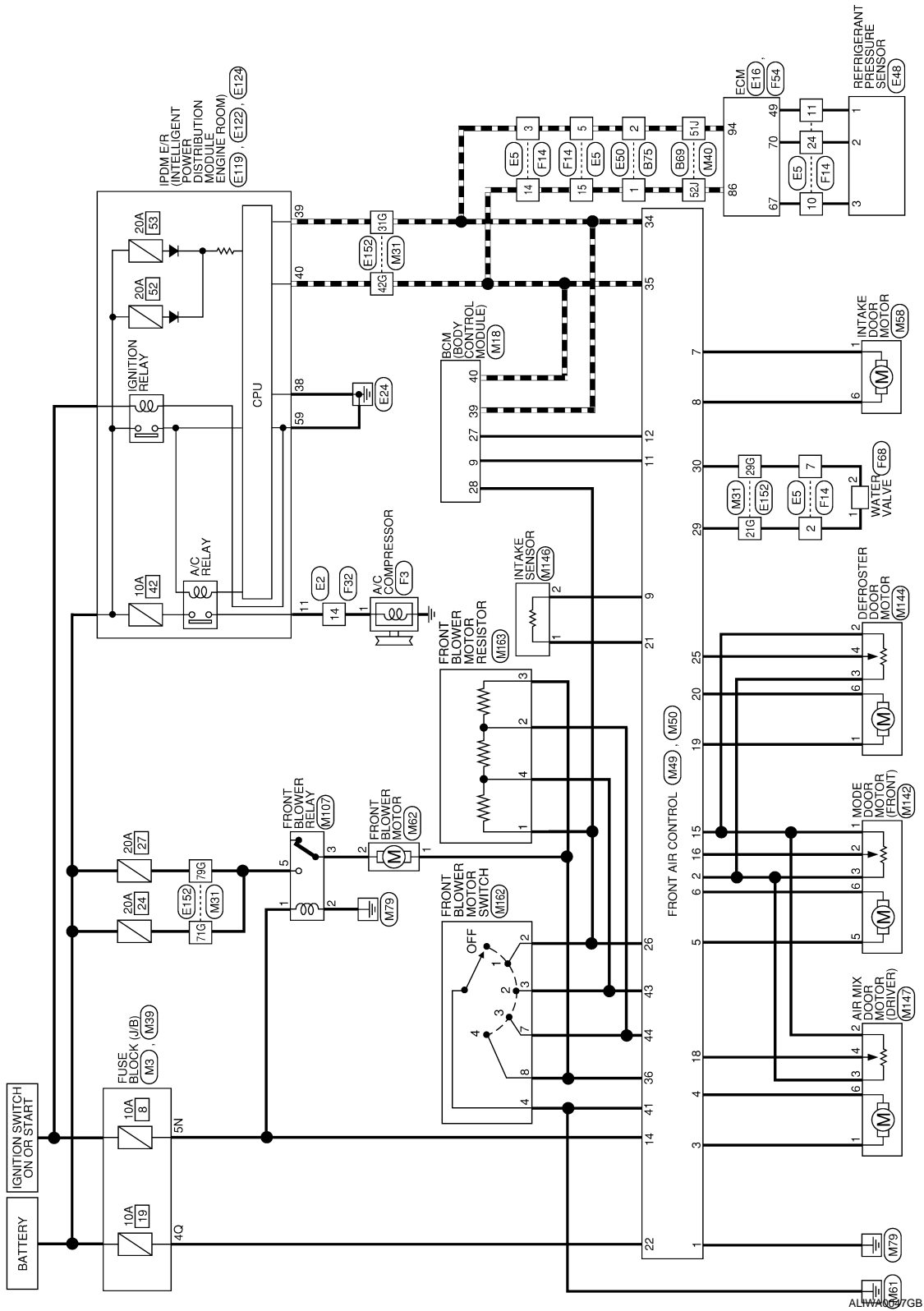

A  
B  
C  
D  
E  
F  
G  
H  
I  
J  
K  
L  
M  
N  
O  
P

HAC

## AIR CONDITIONER CONTROL - MANUAL WITHOUT 3 CONTROL DIAL SYSTEM, WITHOUT VBC CONNECTORS

Connector No.	M3
Connector Name	FUSE BLOCK (J/B)
Connector Color	WHITE

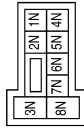

Terminal No.	Color of Wire	Signal Name
5N	Y/G	-

Connector No.	M18
Connector Name	BCM (BODY CONTROL MODULE)
Connector Color	WHITE

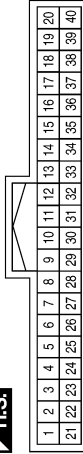

Terminal No.	Color of Wire	Signal Name
9	Y/B	RR DEF SW
27	W/R	AC_SW
28	R/B	BLR_FAN_SW
39	L	CAN-H
40	P	CAN-L

Connector No.	M31
Connector Name	WIRE TO WIRE
Connector Color	WHITE

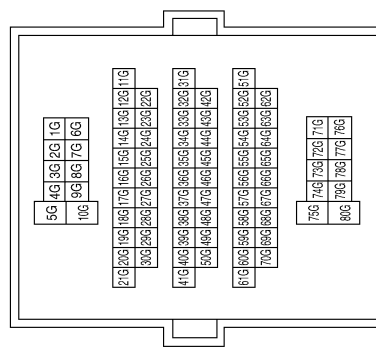

Terminal No.	Color of Wire	Signal Name
21G	Y/L	-
29G	W/G	-
31G	L	-
42G	P	-
71G	P	-
79G	P	-

Connector No.	M39
Connector Name	FUSE BLOCK (J/B)
Connector Color	WHITE



Terminal No.	Color of Wire	Signal Name
4Q	Y/R	-

# AIR CONDITIONER CONTROL

< ECU DIAGNOSIS >

[MANUAL A/C (TYPE 3)]

Terminal No.	Color of Wire	Signal Name
51J	L	-
52J	P	-

Connector No.	M40
Connector Name	WIRE TO WIRE
Connector Color	WHITE

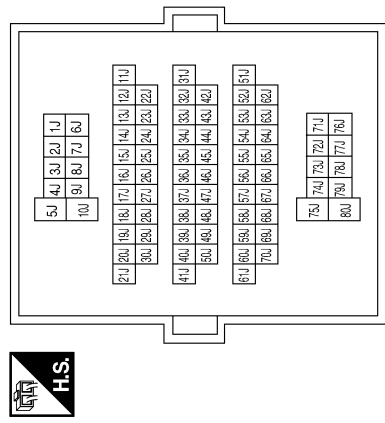

Connector No.	M50
Connector Name	A/C AUTO AMP.
Connector Color	BLUE

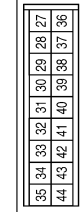

Terminal No.	Color of Wire	Signal Name
29	Y/L	WATER VALVE CLOSE
30	W/G	WATER VALVE OPEN
34	L	CAN-H
35	P	CAN-L
36	L/W	BLOWER SPEED INPUT
41	B/W	BLOWER GND
43	L/R	BLOWER SPEED 2
44	LY	BLOWER SPEED 3

Terminal No.	Color of Wire	Signal Name
11	Y/B	RR DEF REQUEST
12	W/R	AC REQUEST
14	Y/G	IGN
15	P	V REF RETURN
16	GR	PANEL FLOOR FEEDBACK
18	SB	DR BLEND DR FEEDBACK
19	LG	DEFROST CW
20	P/B	DEFROST CCW
21	V/R	SENS RETURN
22	Y/R	VB
25	LG/B	DEFROST FEEDBACK
26	R/B	FR BLOWER MONITOR

Connector No.	M49
Connector Name	A/C AUTO AMP.
Connector Color	BLACK

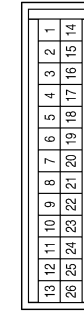

Terminal No.	Color of Wire	Signal Name
1	B	GND
2	Y	V REF ACTR (5V)
3	W/G	DR BLEND DR CW
4	G	DR BLEND DR CCW
5	BR/W	PANEL FLOOR CW
6	P/L	PANEL FLOOR CCW
7	O	RECIRC DOOR CCW
8	G/B	RECIRC DOOR CW
9	L/B	EVAP AIR TEMP SENS

ALIIA0185GB

A  
B  
C  
D  
E  
F  
G  
H  
HAC  
J  
K  
L  
M  
N  
O  
P

# AIR CONDITIONER CONTROL

< ECU DIAGNOSIS >

[MANUAL A/C (TYPE 3)]

Connector No.	M107
Connector Name	FRONT BLOWER RELAY
Connector Color	BLACK

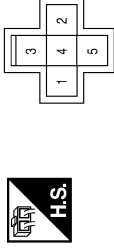

Terminal No.	Color of Wire	Signal Name
1	Y/G	-
2	B	-
3	W/L	-
5	GR	-

Connector No.	M62
Connector Name	FRONT BLOWER MOTOR
Connector Color	BLACK



Terminal No.	Color of Wire	Signal Name
1	L/W	-
2	W/L	-

Connector No.	M58
Connector Name	INTAKE DOOR MOTOR
Connector Color	BLACK



Terminal No.	Color of Wire	Signal Name
1	O	-
6	G/B	-

Connector No.	M146
Connector Name	INTAKE SENSOR
Connector Color	GRAY



Terminal No.	Color of Wire	Signal Name
1	V/R	-
2	L/B	-

Connector No.	M144
Connector Name	DEFROSTER DOOR MOTOR
Connector Color	BLACK



Terminal No.	Color of Wire	Signal Name
1	LG	-
2	P	-
3	Y	-
4	LG/B	-
6	P/B	-

Connector No.	M142
Connector Name	MODE DOOR MOTOR (FRONT)
Connector Color	BLACK

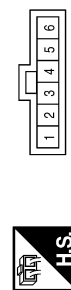

Terminal No.	Color of Wire	Signal Name
1	P	-
2	GR	-
3	Y	-
5	BR/W	-
6	P/L	-

ALIIA0186GB

# AIR CONDITIONER CONTROL

< ECU DIAGNOSIS >

[MANUAL A/C (TYPE 3)]

Connector No.	M147
Connector Name	AIR MIX DOOR MOTOR (DRIVER)
Connector Color	BLACK

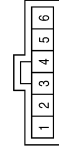

Terminal No.	Color of Wire	Signal Name
1	W/G	-
2	P	-
3	Y	-
4	SB	-
6	G	-

Connector No.	M162
Connector Name	FRONT BLOWER SWITCH
Connector Color	WHITE

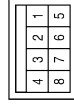

Terminal No.	Color of Wire	Signal Name
2	R/B	-
3	L/R	-
4	B/W	-
7	L/Y	-
8	L/W	-

Connector No.	M163
Connector Name	FRONT BLOWER MOTOR RESISTOR
Connector Color	BLACK

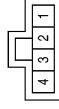

Terminal No.	Color of Wire	Signal Name
1	R/B	-
2	L/Y	-
3	L/W	-
4	L/R	-

Connector No.	E2
Connector Name	WIRE TO WIRE
Connector Color	WHITE



Terminal No.	Color of Wire	Signal Name
14	Y/B	-

Connector No.	E5
Connector Name	WIRE TO WIRE
Connector Color	WHITE



Terminal No.	Color of Wire	Signal Name
2	Y/L	-
3	L	-
5	L	-
7	W/G	-
14	P	-
15	P	-

Connector No.	E16
Connector Name	ECM
Connector Color	BLACK

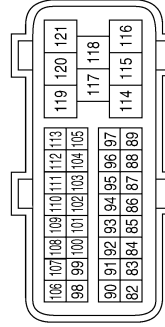

Terminal No.	Color of Wire	Signal Name
86	P	CAN-L
94	L	CAN-H

A  
B  
C  
D  
E  
F  
G  
H  
HAC  
J  
K  
L  
M  
N  
O  
P

# AIR CONDITIONER CONTROL

< ECU DIAGNOSIS >

[MANUAL A/C (TYPE 3)]

Connector No.	E122
Connector Name	IPDM E/R (INTELLIGENT POWER DISTRIBUTION MODULE ENGINE ROOM)
Connector Color	WHITE

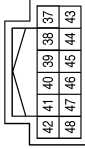

Terminal No.	Color of Wire	Signal Name
38	B	GND (SIG)
39	L	CAN-H
40	P	CAN-L

Connector No.	E119
Connector Name	IPDM E/R (INTELLIGENT POWER DISTRIBUTION MODULE ENGINE ROOM)
Connector Color	WHITE



Terminal No.	Color of Wire	Signal Name
11	Y/B	AC_COMP

Connector No.	E50
Connector Name	WIRE TO WIRE
Connector Color	BROWN



Terminal No.	Color of Wire	Signal Name
1	P	-
2	L	-

Terminal No.	Color of Wire	Signal Name
21G	Y/L	-
29G	W/G	-
31G	L	-
42G	P	-
71G	P	-
79G	GR	-

Connector No.	E152
Connector Name	WIRE TO WIRE
Connector Color	WHITE

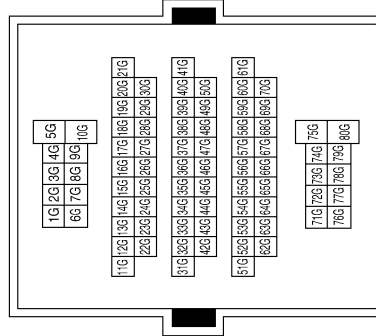

Connector No.	E124
Connector Name	IPDM E/R (INTELLIGENT POWER DISTRIBUTION MODULE ENGINE ROOM)
Connector Color	BLACK



Terminal No.	Color of Wire	Signal Name
59	B	GND (PWR)

ALIIA0188GB

# AIR CONDITIONER CONTROL

< ECU DIAGNOSIS >

[MANUAL A/C (TYPE 3)]

Connector No.	F3
Connector Name	A/C COMPRESSOR
Connector Color	BLACK



Terminal No.	Color of Wire	Signal Name
1	Y/B	-

Connector No.	F14
Connector Name	WIRE TO WIRE
Connector Color	WHITE

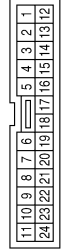

Terminal No.	Color of Wire	Signal Name
2	Y/L	-
3	L	-
5	L	-
7	W/G	-
14	P	-
15	P	-

Connector No.	F32
Connector Name	WIRE TO WIRE
Connector Color	WHITE

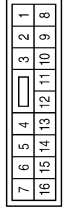

Terminal No.	Color of Wire	Signal Name
14	Y/B	-

Connector No.	F68
Connector Name	WATER VALVE
Connector Color	GRAY



Terminal No.	Color of Wire	Signal Name
1	Y/L	-
2	W/G	-

Connector No.	B69
Connector Name	WIRE TO WIRE
Connector Color	WHITE

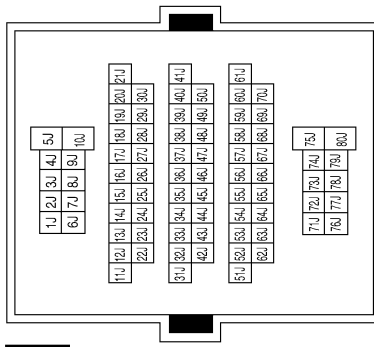

Terminal No.	Color of Wire	Signal Name
51J	L	-
52J	P	-

ALIIA0189GB

A  
B  
C  
D  
E  
F  
G  
H  
HAC  
J  
K  
L  
M  
N  
O  
P

# AIR CONDITIONER CONTROL

< ECU DIAGNOSIS >

[MANUAL A/C (TYPE 3)]

Connector No.	B75
Connector Name	WIRE TO WIRE
Connector Color	BROWN



Terminal No.	Color of Wire	Signal Name
1	P	-
2	L	-

ALIIA0190GB



# MANUAL A/C IDENTIFICATION TABLE

< SYMPTOM DIAGNOSIS >

[MANUAL A/C (TYPE 3)]

## SYMPTOM DIAGNOSIS

### MANUAL A/C IDENTIFICATION TABLE

#### Application Table

INFOID:000000001680590

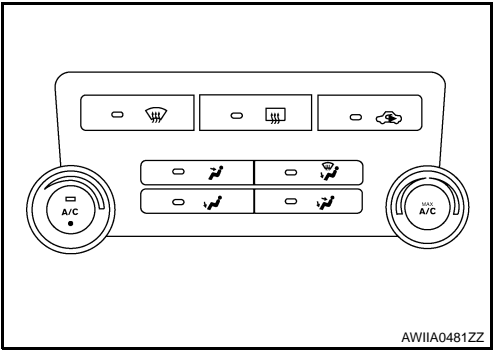
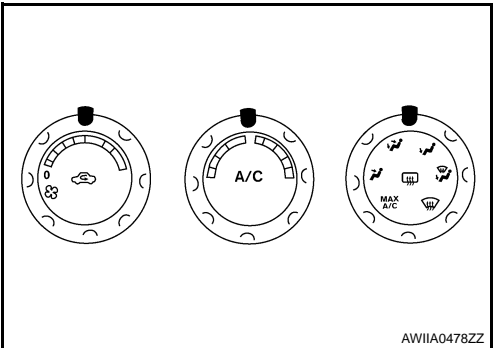
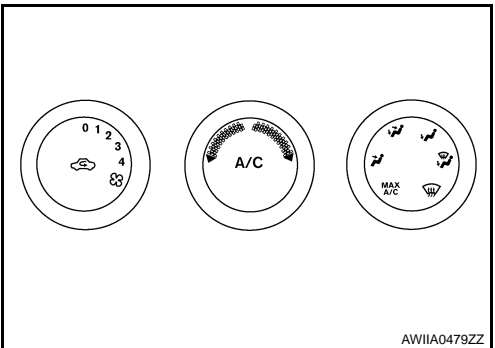
Manual A/C Type	Description	Visual Identification
Manual A/C (Type 1)	Two Control Dial System	
Manual A/C (Type 2)	Three Control Dial System [with variable blower control (VBC)]	
Manual A/C (Type 3)	Three Control Dial System [without variable blower control (VBC)]	

A  
B  
C  
D  
E  
F  
G  
H  
I  
J  
K  
L  
M  
N  
O  
P

HAC

# AIR CONDITIONER CONTROL

< SYMPTOM DIAGNOSIS >

[MANUAL A/C (TYPE 3)]

## AIR CONDITIONER CONTROL

### Symptom Matrix Chart

INFOID:000000001680591

#### SYMPTOM TABLE

Symptom	Reference Page
A/C system does not come on.	Go to Trouble Diagnosis Procedure for A/C System. <a href="#">HAC-309</a>
Air outlet does not change.	Go to Trouble Diagnosis Procedure for Mode Door Motor. <a href="#">HAC-274</a>
Mode door motor is malfunctioning.	
Discharge air temperature does not change.	Go to Trouble Diagnosis Procedure for Air Mix Door Motor. <a href="#">HAC-279</a>
Air mix door motor is malfunctioning.	
Intake door does not change.	Go to Trouble Diagnosis Procedure for Intake Door Motor. <a href="#">HAC-284</a>
Intake door motor is malfunctioning.	
Defroster door motor is malfunctioning.	Go to Trouble Diagnosis Procedure for Defroster Door Motor. <a href="#">HAC-287</a>
Front blower motor operation is malfunctioning.	Go to Trouble Diagnosis Procedure for Front Blower Motor. <a href="#">HAC-292</a>
Magnet clutch does not engage.	Go to Trouble Diagnosis Procedure for Magnet Clutch. <a href="#">HAC-299</a>
Insufficient cooling	Go to Trouble Diagnosis Procedure for Insufficient Cooling. <a href="#">HAC-323</a>
Insufficient heating	Go to Trouble Diagnosis Procedure for Insufficient Heating. <a href="#">HAC-331</a>
Noise	Go to Trouble Diagnosis Procedure for Noise. <a href="#">HAC-333</a>

# INSUFFICIENT COOLING

< SYMPTOM DIAGNOSIS >

[MANUAL A/C (TYPE 3)]

## INSUFFICIENT COOLING

### Component Function Check

INFOID:000000001680592

SYMPTOM: Insufficient cooling

#### INSPECTION FLOW

#### 1. CONFIRM SYMPTOM BY PERFORMING OPERATIONAL CHECK - TEMPERATURE DECREASE

1. Rotate the blower control dial to the low speed.
2. Turn temperature control dial counterclockwise to maximum cold.
3. Check for cold air at discharge air outlets.

Can the symptom be duplicated?

YES >> GO TO 3.

NO >> GO TO 2.

#### 2. CHECK FOR ANY SYMPTOMS

Perform a complete operational check for any symptoms. Refer to [HAC-260, "Operational Check"](#).

Does another symptom exist?

YES >> Refer to [HAC-322, "Symptom Matrix Chart"](#).

NO >> System OK.

#### 3. CHECK FOR SERVICE BULLETINS

Check for any service bulletins.

>> GO TO 3.

#### 4. CHECK DRIVE BELTS

Check compressor belt tension. Refer to [EM-12, "Checking Drive Belts"](#).

Is the inspection result normal?

OK >> GO TO 5.

NG >> Adjust or replace compressor belt. Refer to [EM-12, "Removal and Installation"](#).

#### 5. CHECK AIR MIX DOOR OPERATION

Check and verify air mix door mechanism for smooth operation. Refer to [HAC-279, "Air Mix Door Motor Component Function Check"](#)

Does air mix door operate correctly?

YES >> GO TO 6.

NO >> Check air mix door motor circuit. Refer to [HAC-280, "Air Mix Door Motor Diagnosis Procedure"](#).

#### 6. CHECK COOLING FAN MOTOR OPERATION

Check and verify cooling fan motor for smooth operation. Refer to [EC-386, "Component Inspection"](#).

Does cooling fan motor operate correctly?

YES >> GO TO 7.

NO >> Check cooling fan motor. Refer to [EC-386, "Diagnosis Procedure"](#).

#### 7. CHECK WATER VALVE OPERATION

Check and verify water valve for smooth operation. Refer to [HAC-304, "Description"](#).

Does water valve operate correctly?

YES >> GO TO 8.

NO >> Check water valve circuit. Refer to [HAC-304, "Water Valve Diagnosis Procedure"](#).

#### 8. CHECK RECOVERY/RECYCLING EQUIPMENT BEFORE USAGE

Check recovery/recycling equipment before connecting to vehicle. Verify there is no pressure in the recovery/recycling equipment by checking the gauges. If pressure exists, recover refrigerant from equipment lines.

>> GO TO 9.

A

B

C

D

E

F

G

H

HAC

J

K

L

M

N

O

P

# INSUFFICIENT COOLING

< SYMPTOM DIAGNOSIS >

[MANUAL A/C (TYPE 3)]

---

## 9. CHECK REFRIGERANT PURITY

---

1. Connect recovery/recycling equipment to vehicle.
2. Confirm refrigerant purity in supply tank using recovery/recycling and refrigerant identifier.

Is the inspection result normal?

YES >> GO TO 10.

NO >> Check contaminated refrigerant. Refer to [HAC-335, "Working with HFC-134a \(R-134a\)"](#).

---

## 10. CHECK FOR EVAPORATOR FREEZE UP

---

Start engine and run A/C. Check for evaporator freeze up.

Does evaporator freeze up?

YES >> Perform performance test diagnoses. Refer to [HAC-324, "Performance Test Diagnoses"](#).

NO >> GO TO 11.

---

## 11. CHECK REFRIGERANT PRESSURE

---

Check refrigerant pressure with manifold gauge connected. Refer to [HAC-327, "Test Reading"](#).

Is the inspection result normal?

YES >> Perform performance test diagnoses. Refer to [HAC-324, "Performance Test Diagnoses"](#).

NO >> GO TO 12.

---

## 12. CHECK AIR DUCTS

---

Check ducts for air leaks.

Is the inspection result normal?

YES >> System OK.

NO >> Repair air leaks.

Performance Test Diagnoses

INFOID:000000001680593

# INSUFFICIENT COOLING

< SYMPTOM DIAGNOSIS >

[MANUAL A/C (TYPE 3)]

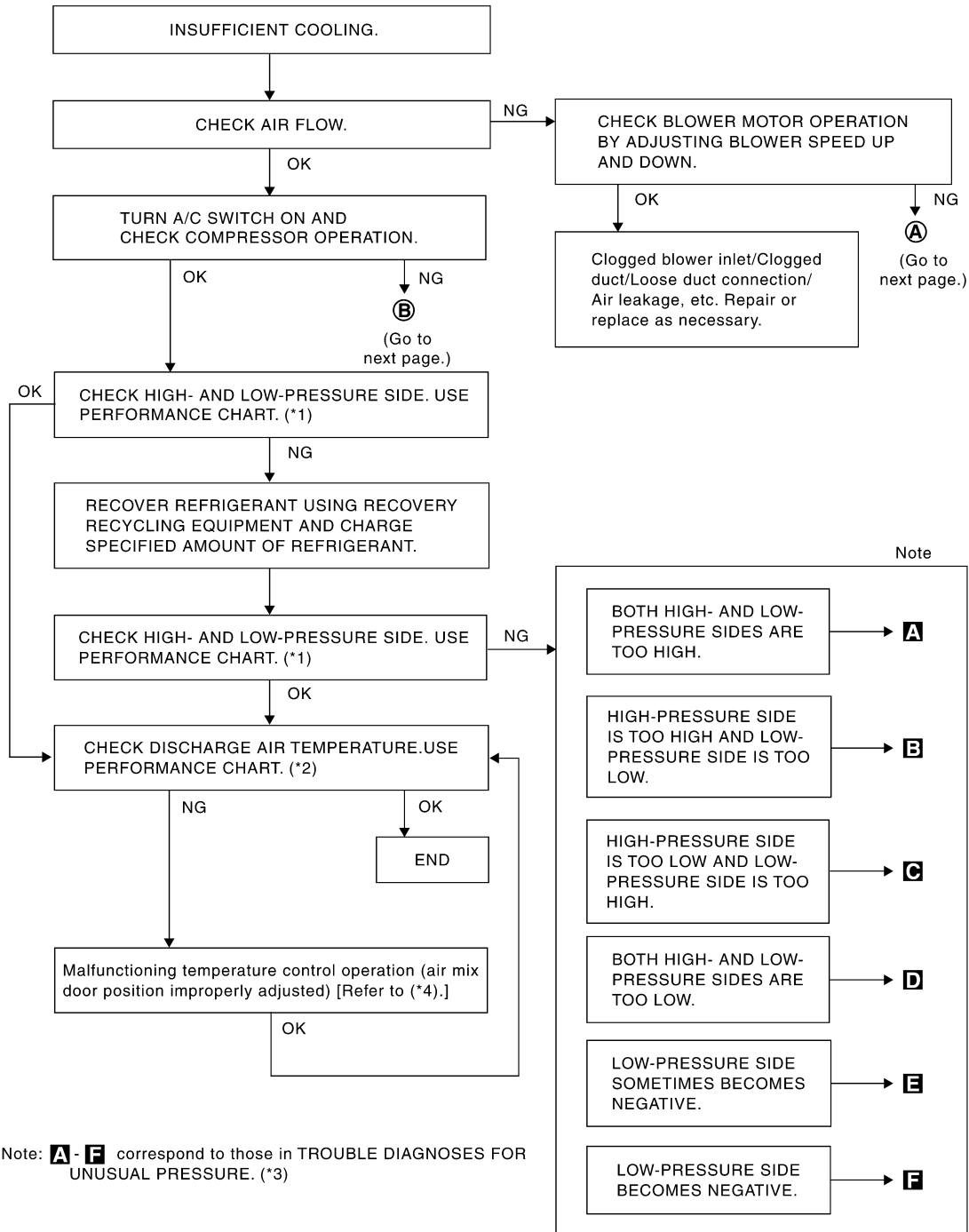

RJA1601E

\*1 [HAC-326. "Performance Chart"](#)

\*2 [HAC-327. "Test Reading"](#)

\*3 [HAC-328. "Trouble Diagnoses for Unusual Pressure"](#)

\*4 [HAC-279. "Air Mix Door Motor Component Function Check"](#)

# INSUFFICIENT COOLING

< SYMPTOM DIAGNOSIS >

[MANUAL A/C (TYPE 3)]

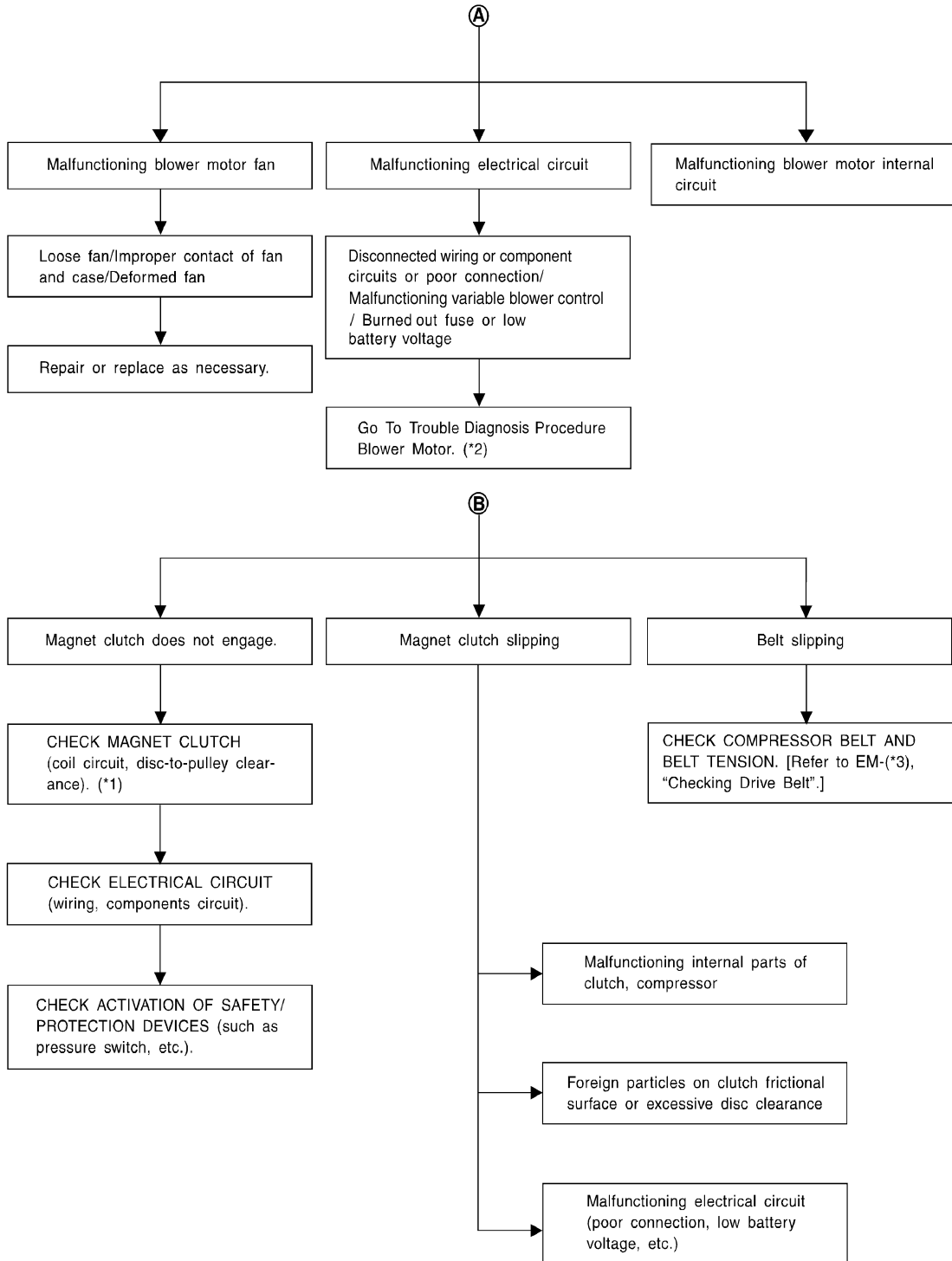

WJIA1371E

\*1 [HA-34. "Removal and Installation for Compressor Clutch"](#)

\*2 [HAC-292. "Front Blower Motor Component Function Check"](#)

\*3 [EM-12. "Checking Drive Belts"](#)

## Performance Chart

INFOID:000000001680594

Test Condition



**HAC-326**

# INSUFFICIENT COOLING

< SYMPTOM DIAGNOSIS >

[MANUAL A/C (TYPE 3)]

Testing must be performed as follows:

Vehicle location	Indoors or in the shade (in a well-ventilated place)
Doors	Closed
Door window	Open
Hood	Open
TEMP.	Max. COLD
Mode control dial	 (Ventilation) set
Recirculation (REC) switch	 (Recirculation) set
 Blower speed	Max. speed set
Engine speed	Idle speed

Operate the air conditioning system for 10 minutes before taking measurements.

## Test Reading

INFOID:000000001680595

### Recirculating-to-discharge Air Temperature Table

Inside air (Recirculating air) at blower assembly inlet		Discharge air temperature at center ventilator °C (°F)
Relative humidity %	Air temperature °C (°F)	
50 - 60	20 (68)	9.9 - 13.9 (50 - 57)
	25 (77)	14.6 - 18.6 (58 - 65)
	30 (86)	16.8 - 21.8 (62 - 71)
	35 (95)	21.1 - 27.1 (70 - 81)
	40 (104)	25.3 - 31.5 (78 - 89)
60 - 70	20 (68)	11.4 - 15.2 (53 - 59)
	25 (77)	15.5 - 20.0 (60 - 68)
	30 (86)	19.9 - 25.0 (68 - 77)
	35 (95)	24.5 - 29.6 (76 - 85)
	40 (104)	28.7 - 34.9 (84 - 95)

### Ambient Air Temperature-to-operating Pressure Table

Ambient air		High-pressure (Discharge side) kPa (kg/cm <sup>2</sup> , psi)	Low-pressure (Suction side) kPa (kg/cm <sup>2</sup> , psi)
Relative humidity %	Air temperature °C (°F)		
50 - 70	20 (68)	1020 - 1250 (10.4 - 12.7, 147.9 - 181.3)	160 - 190 (1.63 - 1.94, 23.2 - 27.6)
	25 (77)	1236 - 1510 (12.6 - 15.4, 179.2 - 219)	206 - 245 (2.1 - 2.5, 29.9 - 35.6)
	30 (86)	1569 - 1,922 (16.0 - 19.6, 227.6 - 278.8)	265 - 324 (2.7 - 3.3, 38.4 - 46.9)
	35 (95)	1,697 - 2079 (17.3 - 21.2, 246.1 - 301.5)	304 - 363 (3.1 - 3.7, 44.1 - 52.6)
	40 (104)	1971 - 2403 (20.1 - 24.5, 285.9 - 348.5)	373 - 451 (3.8 - 4.6, 54.0 - 65.4)

# INSUFFICIENT COOLING

< SYMPTOM DIAGNOSIS >

[MANUAL A/C (TYPE 3)]

## Trouble Diagnoses for Unusual Pressure

INFOID:000000001680596

Whenever system's high and/or low side pressure is unusual, diagnose using a manifold gauge. The marker above the gauge scale in the following tables indicates the standard (usual) pressure range. Since the standard (usual) pressure, however, differs from vehicle to vehicle, refer to above table (Ambient air temperature-to-operating pressure table).

### Both High- and Low-pressure Sides are Too High

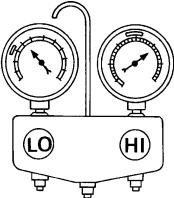
Gauge indication	Refrigerant cycle	Probable cause	Corrective action
<p>Both high- and low-pressure sides are too high.</p>  <p style="text-align: center;">AC359A</p>	Pressure is reduced soon after water is splashed on condenser.	Excessive refrigerant charge in refrigeration cycle	Reduce refrigerant until specified pressure is obtained.
	Air suction by cooling fan is insufficient.	Insufficient condenser cooling performance ↓ 1. Condenser fins are clogged. 2. Improper fan rotation of cooling fan	<ul style="list-style-type: none"> <li>Clean condenser.</li> <li>Check and repair cooling fan if necessary.</li> </ul>
	<ul style="list-style-type: none"> <li>Low-pressure pipe is not cold.</li> <li>When compressor is stopped high-pressure value quickly drops by approximately 196 kPa (2 kg/cm<sup>2</sup>, 28 psi). It then decreases gradually thereafter.</li> </ul>	Poor heat exchange in condenser (After compressor operation stops, high-pressure decreases too slowly.) ↓ Air in refrigeration cycle	Evacuate and recharge system.
	Engine tends to overheat.	Engine cooling systems malfunction.	Check and repair engine cooling system.
	<ul style="list-style-type: none"> <li>An area of the low-pressure pipe is colder than areas near the evaporator outlet.</li> <li>Plates are sometimes covered with frost.</li> </ul>	<ul style="list-style-type: none"> <li>Excessive liquid refrigerant on low-pressure side</li> <li>Excessive refrigerant discharge flow</li> <li>Expansion valve is open a little compared with the specification.</li> </ul> ↓ Improper expansion valve adjustment	Replace expansion valve.

### High-pressure Side is Too High and Low-pressure Side is Too Low

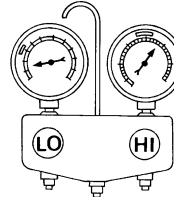
Gauge indication	Refrigerant cycle	Probable cause	Corrective action
<p>High-pressure side is too high and low-pressure side is too low.</p>  <p style="text-align: center;">AC360A</p>	Upper side of condenser and high-pressure side are hot, however, liquid tank is not so hot.	High-pressure tube or parts located between compressor and condenser are clogged or crushed.	<ul style="list-style-type: none"> <li>Check and repair or replace malfunctioning parts.</li> <li>Check oil for contamination.</li> </ul>

### High-pressure Side is Too Low and Low-pressure Side is Too High



# INSUFFICIENT COOLING

< SYMPTOM DIAGNOSIS >

[MANUAL A/C (TYPE 3)]

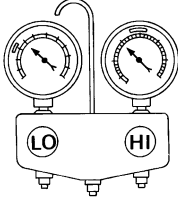
Gauge indication	Refrigerant cycle	Probable cause	Corrective action
High-pressure side is too low and low-pressure side is too high.  	High- and low-pressure sides become equal soon after compressor operation stops.	Compressor pressure operation is improper. ↓ Damaged inside compressor packings.	Replace compressor.
	No temperature difference between high- and low-pressure sides.	Compressor pressure operation is improper. ↓ Damaged inside compressor packings.	Replace compressor.

A  
B  
C  
D

## Both High- and Low-pressure Sides are Too Low

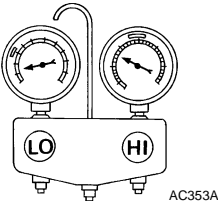
Gauge indication	Refrigerant cycle	Probable cause	Corrective action
Both high- and low-pressure sides are too low.  	<ul style="list-style-type: none"> <li>There is a big temperature difference between liquid tank outlet and inlet. Outlet temperature is extremely low.</li> <li>Liquid tank inlet and expansion valve are frosted.</li> </ul>	Liquid tank inside is slightly clogged.	<ul style="list-style-type: none"> <li>Replace liquid tank.</li> <li>Check oil for contamination.</li> </ul>
	<ul style="list-style-type: none"> <li>Temperature of expansion valve inlet is extremely low as compared with areas near liquid tank.</li> <li>Expansion valve inlet may be frosted.</li> <li>Temperature difference occurs somewhere in high-pressure side.</li> </ul>	High-pressure pipe located between liquid tank and expansion valve is clogged.	<ul style="list-style-type: none"> <li>Check and repair malfunctioning parts.</li> <li>Check oil for contamination.</li> </ul>
	Expansion valve and liquid tank are warm or only cool when touched.	Low refrigerant charge. ↓ Leaking fittings or components.	Check refrigerant system for leaks. Refer to <a href="#">HA-23, "Checking of Refrigerant Leaks"</a> .
	There is a big temperature difference between expansion valve inlet and outlet while the valve itself is frosted.	Expansion valve closes a little compared with the specification. ↓ 1. Improper expansion valve adjustment. 2. Malfunctioning expansion valve. 3. Outlet and inlet may be clogged.	<ul style="list-style-type: none"> <li>Remove foreign particles by using compressed air.</li> <li>Check oil for contamination.</li> </ul>
An area of the low-pressure pipe is colder than areas near the evaporator outlet.	Low-pressure pipe is clogged or crushed.	<ul style="list-style-type: none"> <li>Check and repair malfunctioning parts.</li> <li>Check oil for contamination.</li> </ul>	
Air flow volume is too low.	Evaporator is frozen.	<ul style="list-style-type: none"> <li>Check intake sensor circuit. Refer to <a href="#">HAC-306, "Intake Sensor Diagnosis Procedure"</a>.</li> <li>Repair evaporator fins.</li> <li>Replace evaporator.</li> <li>Refer to <a href="#">HAC-292, "Front Blower Motor Component Function Check"</a>.</li> </ul>	

E  
F  
G  
H  
J  
K  
L  
M  
N  
O  
P

HAC

Low-pressure Side Sometimes Becomes Negative

# INSUFFICIENT COOLING

< SYMPTOM DIAGNOSIS >

[MANUAL A/C (TYPE 3)]

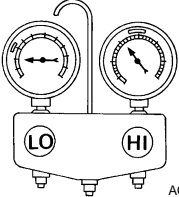
Gauge indication	Refrigerant cycle	Probable cause	Corrective action
<p>Low-pressure side sometimes becomes negative.</p>  <p style="text-align: right; font-size: small;">AC354A</p>	<ul style="list-style-type: none"> <li>• Air conditioning system does not function and does not cyclically cool the compartment air.</li> <li>• The system constantly functions for a certain period of time after compressor is stopped and restarted.</li> </ul>	<p>Refrigerant does not discharge cyclically.</p> <p>↓</p> <p>Moisture is frozen at expansion valve outlet and inlet.</p> <p>↓</p> <p>Water is mixed with refrigerant.</p>	<ul style="list-style-type: none"> <li>• Drain water from refrigerant or replace refrigerant.</li> <li>• Replace liquid tank.</li> </ul>

## Low-pressure Side Becomes Negative

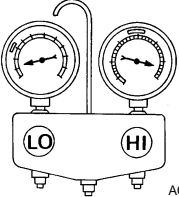
Gauge indication	Refrigerant cycle	Probable cause	Corrective action
<p>Low-pressure side becomes negative.</p>  <p style="text-align: right; font-size: small;">AC362A</p>	<p>Liquid tank or front/rear side of expansion valve's pipe is frosted or dewed.</p>	<p>High-pressure side is closed and refrigerant does not flow.</p> <p>↓</p> <p>Expansion valve or liquid tank is frosted.</p>	<p>Leave the system at rest until no frost is present. Start it again to check whether or not the malfunction is caused by water or foreign particles.</p> <ul style="list-style-type: none"> <li>• If water is the cause, initially cooling is okay. Then the water freezes causing a blockage. Drain water from refrigerant or replace refrigerant.</li> <li>• If due to foreign particles, remove expansion valve and remove the particles with dry and compressed air (not shop air).</li> <li>• If either of the above methods cannot correct the malfunction, replace expansion valve.</li> <li>• Replace liquid tank.</li> <li>• Check oil for contamination.</li> </ul>

**INSUFFICIENT HEATING****Component Function Check**

INFOID:000000001680597

SYMPTOM: Insufficient heating

**INSPECTION FLOW****1. CONFIRM SYMPTOM BY PERFORMING OPERATIONAL CHECK - TEMPERATURE INCREASE**

1. Turn the blower control dial to low speed.
2. Turn the temperature control dial clockwise to maximum heat
3. Check for hot air at discharge air outlets.

Can this symptom be duplicated?

YES &gt;&gt; GO TO 2.

NO >> Perform complete system operational check. Refer to [HAC-260, "Operational Check"](#).**2. CHECK FOR SERVICE BULLETINS**

Check for any service bulletins.

&gt;&gt; GO TO 3.

**3. CHECK ENGINE COOLING SYSTEM**

1. Check for proper engine coolant level. Refer to [CO-10, "Inspection"](#).
2. Check hoses for leaks or kinks.
3. Check radiator cap. Refer to [CO-10, "Inspection"](#).
4. Check for air in cooling system.

&gt;&gt; GO TO 4.

**4. CHECK AIR MIX DOOR OPERATION**

Check the operation of the air mix door.

Is the inspection result normal?

YES &gt;&gt; GO TO 5.

NO >> Check the air mix door motor circuit. Refer to [HAC-279, "Air Mix Door Motor Component Function Check"](#).**5. CHECK AIR DUCTS**

Check for disconnected or leaking air ducts.

Is the inspection result normal?

YES &gt;&gt; GO TO 6.

NO &gt;&gt; Repair all disconnected or leaking air ducts.

**6. CHECK HEATER HOSE TEMPERATURES**

1. Start engine and warm it up to normal operating temperature.
2. Touch both the inlet and outlet heater hoses.

Is the inspection result normal?

YES &gt;&gt; Hot inlet hose and a warm outlet hose: GO TO 7.

NO >> • Inlet hose cold: GO TO 10.  
• Both hoses warm: GO TO 8.**7. CHECK ENGINE COOLANT SYSTEM**Check engine control temperature sensor. Refer to [EC-126, "Component Inspection"](#).Is the inspection result normal?

YES &gt;&gt; System OK.

NO &gt;&gt; Repair or replace as necessary. Retest.

**8. CHECK HEATER HOSES**

Check heater hoses for proper installation.

A

B

C

D

E

F

G

H

HAC

J

K

L

M

N

O

P

# INSUFFICIENT HEATING

< SYMPTOM DIAGNOSIS >

[MANUAL A/C (TYPE 3)]

---

Is the inspection result normal?

YES >> System OK.

NO >> 1. Back flush heater core.

2. Drain the water from the system.

3. Refill system with new engine coolant. Refer to [CO-11, "Changing Engine Coolant"](#).

4. GO TO 10 to retest.

## 9. CHECK HEATER HOSE TEMPERATURES

---

1. Start engine and warm it up to normal operating temperature.

2. Touch both the inlet and outlet heater hoses.

Is the inspection result normal?

YES >> System OK.

NO >> Replace heater core. Refer to [VTL-15, "Removal and Installation"](#).

## 10. CHECK WATER VALVE

---

Check the operation of the water valve. Refer to [HAC-304, "Water Valve Diagnosis Procedure"](#).

Is the inspection result normal?

YES >> System OK.

NO >> Replace water valve.

NOISE

Component Function Check

INFOID:000000001680598

SYMPTOM: Noise

INSPECTION FLOW

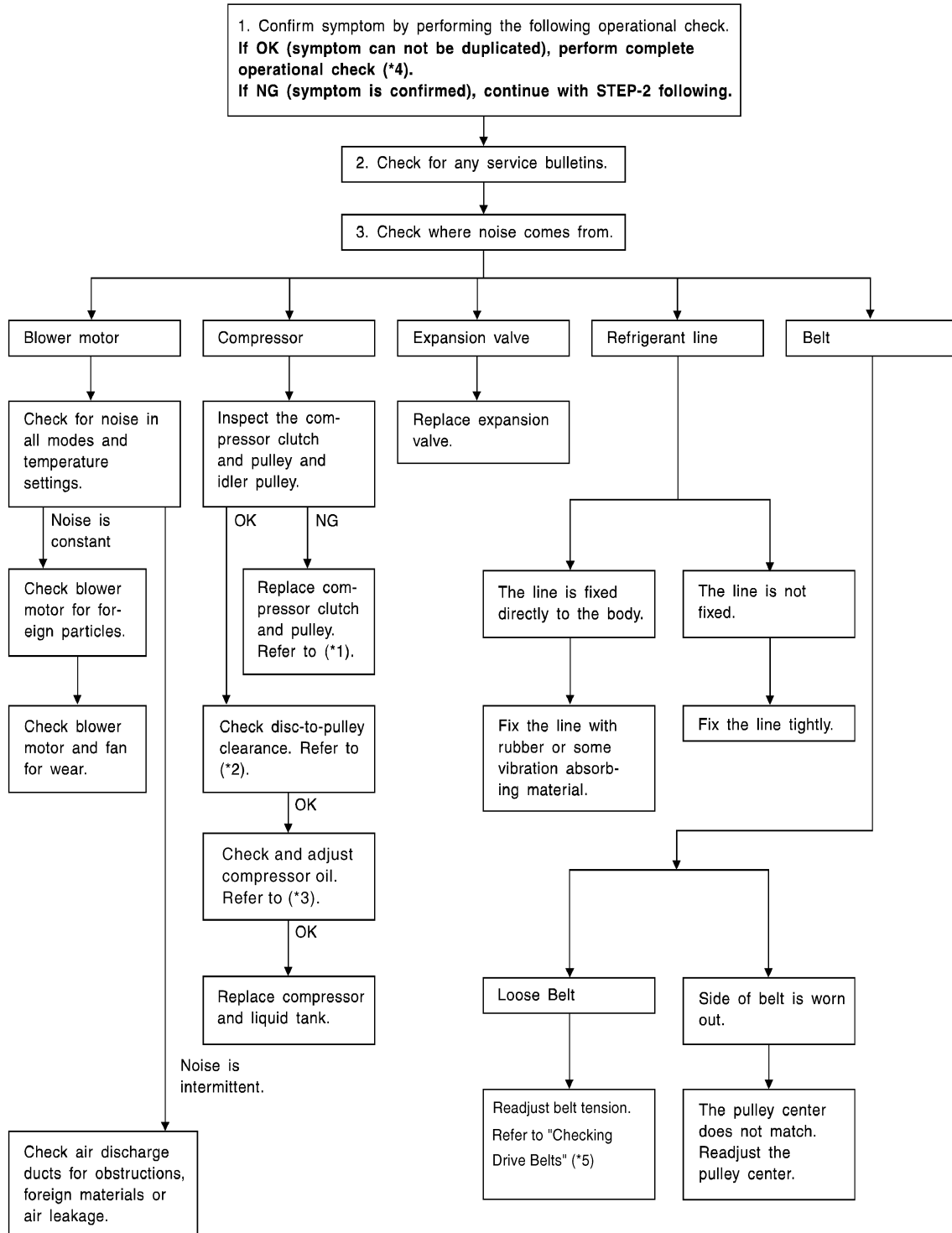

A  
B  
C  
D  
E  
F  
G  
H  
HAC  
J  
K  
L  
M  
N  
O  
P

# NOISE

< SYMPTOM DIAGNOSIS >

[MANUAL A/C (TYPE 3)]

---

- \*1 [HA-34. "Removal and Installation for Compressor Clutch"](#)
- \*2 [HA-34. "Removal and Installation for Compressor Clutch"](#)
- \*3 [HA-20. "Maintenance of Oil Quantity in Compressor"](#)
- \*4 [HAC-260. "Operational Check"](#)
- \*5 [EM-12. "Checking Drive Belts"](#)

PRECAUTION

PRECAUTIONS

Supplemental Restraint System (SRS) "AIR BAG" and "SEAT BELT PRE-TENSIONER"

INFOID:000000001680599

The Supplemental Restraint System such as "AIR BAG" and "SEAT BELT PRE-TENSIONER", used along with a front seat belt, helps to reduce the risk or severity of injury to the driver and front passenger for certain types of collision. This system includes seat belt switch inputs and dual stage front air bag modules. The SRS system uses the seat belt switches to determine the front air bag deployment, and may only deploy one front air bag, depending on the severity of a collision and whether the front occupants are belted or unbelted. Information necessary to service the system safely is included in the SR and SB section of this Service Manual.

**WARNING:**

- To avoid rendering the SRS inoperative, which could increase the risk of personal injury or death in the event of a collision which would result in air bag inflation, all maintenance must be performed by an authorized NISSAN/INFINITI dealer.
- Improper maintenance, including incorrect removal and installation of the SRS, can lead to personal injury caused by unintentional activation of the system. For removal of Spiral Cable and Air Bag Module, see the SR section.
- Do not use electrical test equipment on any circuit related to the SRS unless instructed to in this Service Manual. SRS wiring harnesses can be identified by yellow and/or orange harnesses or harness connectors.

Working with HFC-134a (R-134a)

INFOID:000000001680600

**WARNING:**

- CFC-12 (R-12) refrigerant and HFC-134a (R-134a) refrigerant are not compatible. If the refrigerants are mixed compressor failure is likely to occur. Refer to HA-4, "[Contaminated Refrigerant](#)". To determine the purity of HFC-134a (R-134a) in the vehicle and recovery tank, use Refrigerant Recovery/Recycling Recharging equipment and Refrigerant Identifier.
- Use only specified oil for the HFC-134a (R-134a) A/C system and HFC-134a (R-134a) components. If oil other than that specified is used, compressor failure is likely to occur.
- The specified HFC-134a (R-134a) oil rapidly absorbs moisture from the atmosphere. The following handling precautions must be observed:
  - When removing refrigerant components from a vehicle, immediately cap (seal) the component to minimize the entry of moisture from the atmosphere.
  - When installing refrigerant components to a vehicle, do not remove the caps (unseal) until just before connecting the components. Connect all refrigerant loop components as quickly as possible to minimize the entry of moisture into system.
  - Only use the specified oil from a sealed container. Immediately reseal containers of oil. Without proper sealing, oil will become moisture saturated and should not be used.
  - Avoid breathing A/C refrigerant and oil vapor or mist. Exposure may irritate eyes, nose and throat. Remove HFC-134a (R-134a) from the A/C system using certified service equipment meeting requirements of SAE J2210 [HFC-134a (R-134a) recycling equipment], or J2209 [HFC-134a (R-134a) recycling equipment], If accidental system discharge occurs, ventilate work area before resuming service. Additional health and safety information may be obtained from refrigerant and oil manufacturers.
  - Do not allow A/C oil to come in contact with styrofoam parts. Damage may result.

CONTAMINATED REFRIGERANT

If a refrigerant other than pure HFC-134a (R-134a) is identified in a vehicle, your options are:

- Explain to the customer that environmental regulations prohibit the release of contaminated refrigerant into the atmosphere.
- Explain that recovery of the contaminated refrigerant could damage your service equipment and refrigerant supply.
- Suggest the customer return the vehicle to the location of previous service where the contamination may have occurred.
- If you choose to perform the repair, recover the refrigerant using only **dedicated equipment and containers. Do not recover contaminated refrigerant into your existing service equipment.** If your facility does

A  
B  
C  
D  
E  
F  
G  
H  
HAC  
J  
K  
L  
M  
N  
O  
P

# PRECAUTIONS

[MANUAL A/C (TYPE 3)]

## < PRECAUTION >

not have dedicated recovery equipment, you may contact a local refrigerant product retailer for available service. This refrigerant must be disposed of in accordance with all federal and local regulations. In addition, replacement of all refrigerant system components on the vehicle is recommended.

- If the vehicle is within the warranty period, the air conditioner warranty is void. Please contact NISSAN Customer Affairs for further assistance.

## Precaution for Service Equipment

INFOID:000000001680601

### MANIFOLD GAUGE SET

Be certain that the gauge face indicates R-134a or 134a. Make sure the gauge set has 1/2"-16 ACME threaded connections for service hoses. Confirm the set has been used only with refrigerant HFC-134a (R-134a) along with specified oil.

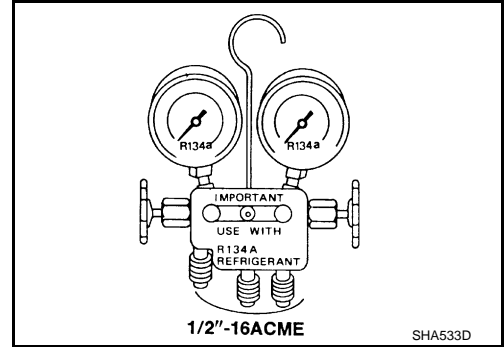

### SERVICE HOSES

Be certain that the service hoses display the markings described (colored hose with black stripe). All hoses must include positive shut-off devices (either manual or automatic) near the end of the hoses opposite the manifold gauge.

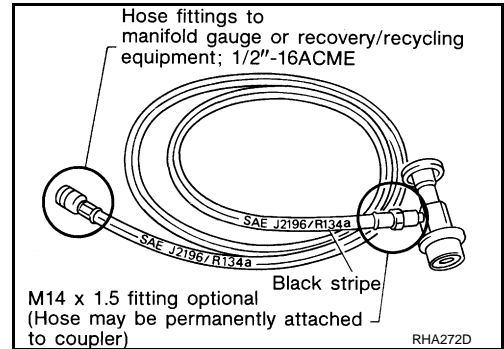

### SERVICE COUPLERS

Never attempt to connect HFC-134a (R-134a) service couplers to a CFC-12 (R-12) A/C system. The HFC-134a (R-134a) couplers will not properly connect to the CFC-12 (R-12) system. However, if an improper connection is attempted, discharging and contamination may occur.

Shut-off valve rotation	A/C service valve
Clockwise	Open
Counterclockwise	Close

