

A
B
C

SECTION INL

INTERIOR LIGHTING SYSTEM

CONTENTS

<p>BASIC INSPECTION 3</p> <p>DIAGNOSIS AND REPAIR WORKFLOW 3</p> <p style="padding-left: 20px;">Work Flow3</p> <p>FUNCTION DIAGNOSIS 6</p> <p>INTERIOR ROOM LAMP CONTROL SYSTEM 6</p> <p style="padding-left: 20px;">System Diagram6</p> <p style="padding-left: 20px;">System Description6</p> <p style="padding-left: 20px;">Component Parts Location7</p> <p style="padding-left: 20px;">Component Description8</p> <p>ILLUMINATION CONTROL SYSTEM 9</p> <p style="padding-left: 20px;">System Diagram9</p> <p style="padding-left: 20px;">System Description9</p> <p style="padding-left: 20px;">Component Parts Location9</p> <p style="padding-left: 20px;">Component Description10</p> <p>DIAGNOSIS SYSTEM (BCM)11</p> <p>COMMON ITEM11</p> <p style="padding-left: 20px;">COMMON ITEM : CONSULT-III Function11</p> <p>INT LAMP11</p> <p style="padding-left: 20px;">INT LAMP : CONSULT-III Function11</p> <p>BATTERY SAVER13</p> <p style="padding-left: 20px;">BATTERY SAVER : CONSULT-III Function13</p> <p>COMPONENT DIAGNOSIS15</p> <p>POWER SUPPLY AND GROUND CIRCUIT15</p> <p>BCM15</p> <p style="padding-left: 20px;">BCM : Inspection Procedure15</p> <p>BATTERY SAVER OUTPUT/POWER SUPPLY CIRCUIT16</p> <p style="padding-left: 20px;">Description16</p> <p style="padding-left: 20px;">Component Function Check16</p> <p style="padding-left: 20px;">Diagnosis Procedure16</p>	<p>INTERIOR ROOM LAMP CONTROL CIRCUIT18</p> <p style="padding-left: 20px;">Description18</p> <p style="padding-left: 20px;">Component Function Check18</p> <p style="padding-left: 20px;">Diagnosis Procedure18</p> <p>STEP LAMP CIRCUIT21</p> <p style="padding-left: 20px;">Description21</p> <p style="padding-left: 20px;">Component Function Check21</p> <p style="padding-left: 20px;">Diagnosis Procedure21</p> <p>CARGO LAMP CONTROL CIRCUIT23</p> <p style="padding-left: 20px;">Description23</p> <p style="padding-left: 20px;">Component Function Check23</p> <p style="padding-left: 20px;">Diagnosis Procedure23</p> <p>INTERIOR ROOM LAMP CONTROL SYSTEM25</p> <p style="padding-left: 20px;">Wiring Diagram25</p> <p>ILLUMINATION41</p> <p style="padding-left: 20px;">Wiring Diagram41</p> <p>ECU DIAGNOSIS55</p> <p>BCM (BODY CONTROL MODULE)55</p> <p style="padding-left: 20px;">Description55</p> <p>SYMPTOM DIAGNOSIS56</p> <p>INTERIOR LIGHTING SYSTEM SYMPTOMS ...56</p> <p style="padding-left: 20px;">Symptom Table56</p> <p>PRECAUTION57</p> <p>PRECAUTIONS57</p> <p style="padding-left: 20px;">Supplemental Restraint System (SRS) "AIR BAG" and "SEAT BELT PRE-TENSIONER"57</p> <p style="padding-left: 20px;">General precautions for service operations57</p> <p>ON-VEHICLE REPAIR58</p> <p>INTERIOR ROOM LAMP58</p>
---	---

A
B
C
D
E
F
G
H
I
J
K
INL

Removal and Installation	58	SERVICE DATA AND SPECIFICATIONS	
ILLUMINATION	63	(SDS)	65
Removal and Installation	63	BULB SPECIFICATIONS	65
		Interior Lamp/Illumination	65

DIAGNOSIS AND REPAIR WORKFLOW

< BASIC INSPECTION >

BASIC INSPECTION

DIAGNOSIS AND REPAIR WORKFLOW

Work Flow

INFOID:000000001621665

OVERALL SEQUENCE

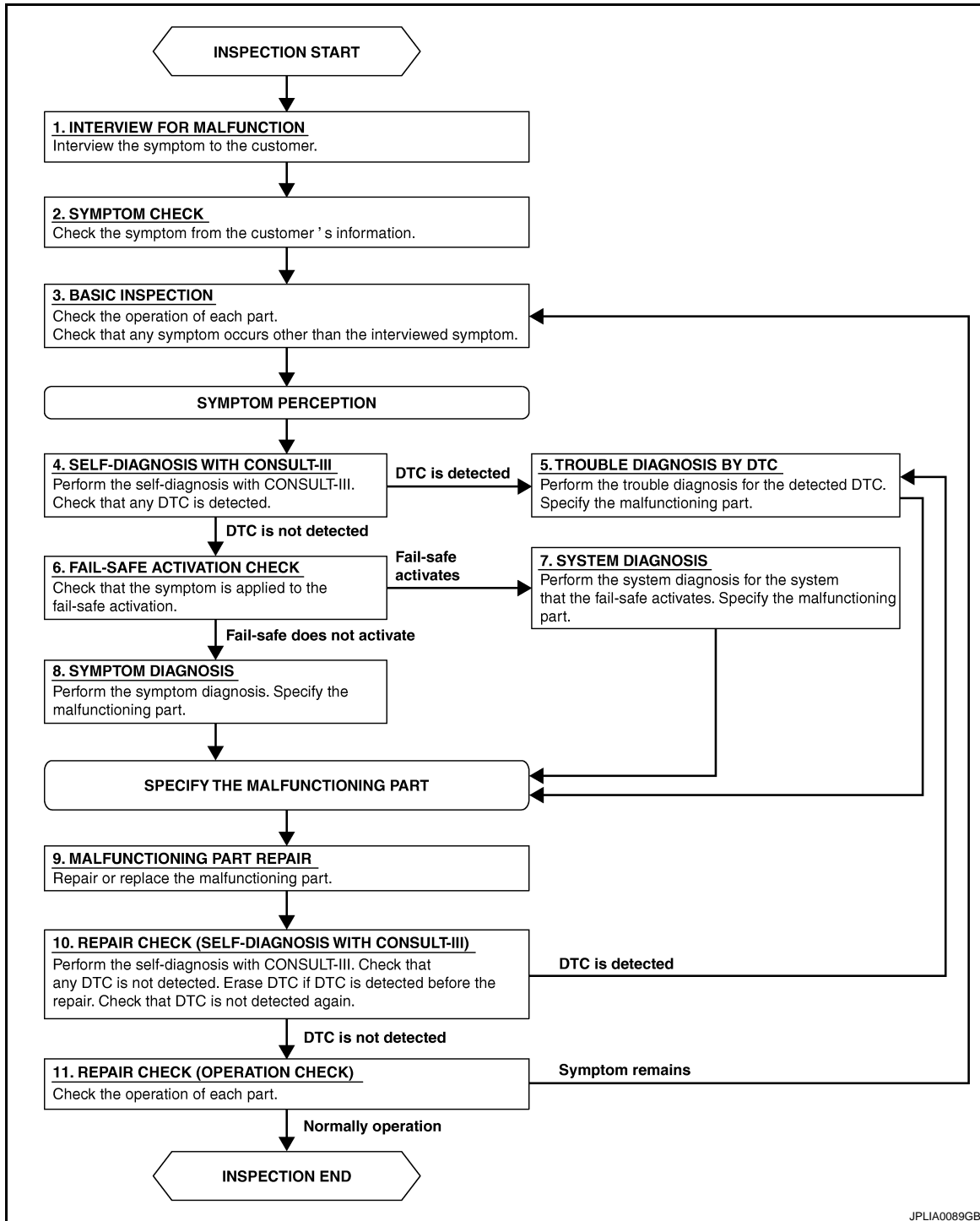

A
B
C
D
E
F
G
H
I
J
K
L
M
N
O
P

INL

DIAGNOSIS AND REPAIR WORKFLOW

< BASIC INSPECTION >

DETAILED FLOW

1. INTERVIEW FOR MALFUNCTION

Find out what the customer's concerns are.

>> GO TO 2

2. SYMPTOM CHECK

Verify the symptom from the customer's information.

>> GO TO 3

3. BASIC INSPECTION

Check the operation of each part. Check that any concerns occur other than those mentioned in the customer interview.

>> GO TO 4

4. SELF-DIAGNOSIS WITH CONSULT-III

Perform the self-diagnosis with CONSULT-III. Check that any DTC is detected.

Is any DTC detected?

YES >> GO TO 5

NO >> GO TO 6

5. TROUBLE DIAGNOSIS BY DTC

Perform the trouble diagnosis for the detected DTC. Specify the malfunctioning part.

>> GO TO 9

6. FAIL-SAFE ACTIVATION CHECK

Determine if the customer's concern is related to fail-safe activation.

Does the fail-safe activate?

YES >> GO TO 7

NO >> GO TO 8

7. SYSTEM DIAGNOSIS

Perform the system diagnosis for the system in which the fail-safe activates. Specify the malfunctioning part.

>> GO TO 9

8. SYMPTOM DIAGNOSIS

Perform the symptom diagnosis. Specify the malfunctioning part.

>> GO TO 9

9. MALFUNCTION PART REPAIR

Repair or replace the malfunctioning part.

>> GO TO 11

10. REPAIR CHECK (SELF-DIAGNOSIS WITH CONSULT-III)

Perform the self-diagnosis with CONSULT-III. Verified that no DTCs are detected. Erase all DTCs detected prior to the repair. Verify that DTC is not detected again.

Is any DTC detected?

DIAGNOSIS AND REPAIR WORKFLOW

< BASIC INSPECTION >

YES >> GO TO 5

NO >> GO TO 11

11. REPAIR CHECK (OPERATION CHECK)

Check the operation of each part.

Does it operate normally?

YES >> INSPECTION END

NO >> GO TO 3

A

B

C

D

E

F

G

H

I

J

K

INL

M

N

O

P

INTERIOR ROOM LAMP CONTROL SYSTEM

< FUNCTION DIAGNOSIS >

FUNCTION DIAGNOSIS

INTERIOR ROOM LAMP CONTROL SYSTEM

System Diagram

INFOID:000000001621666

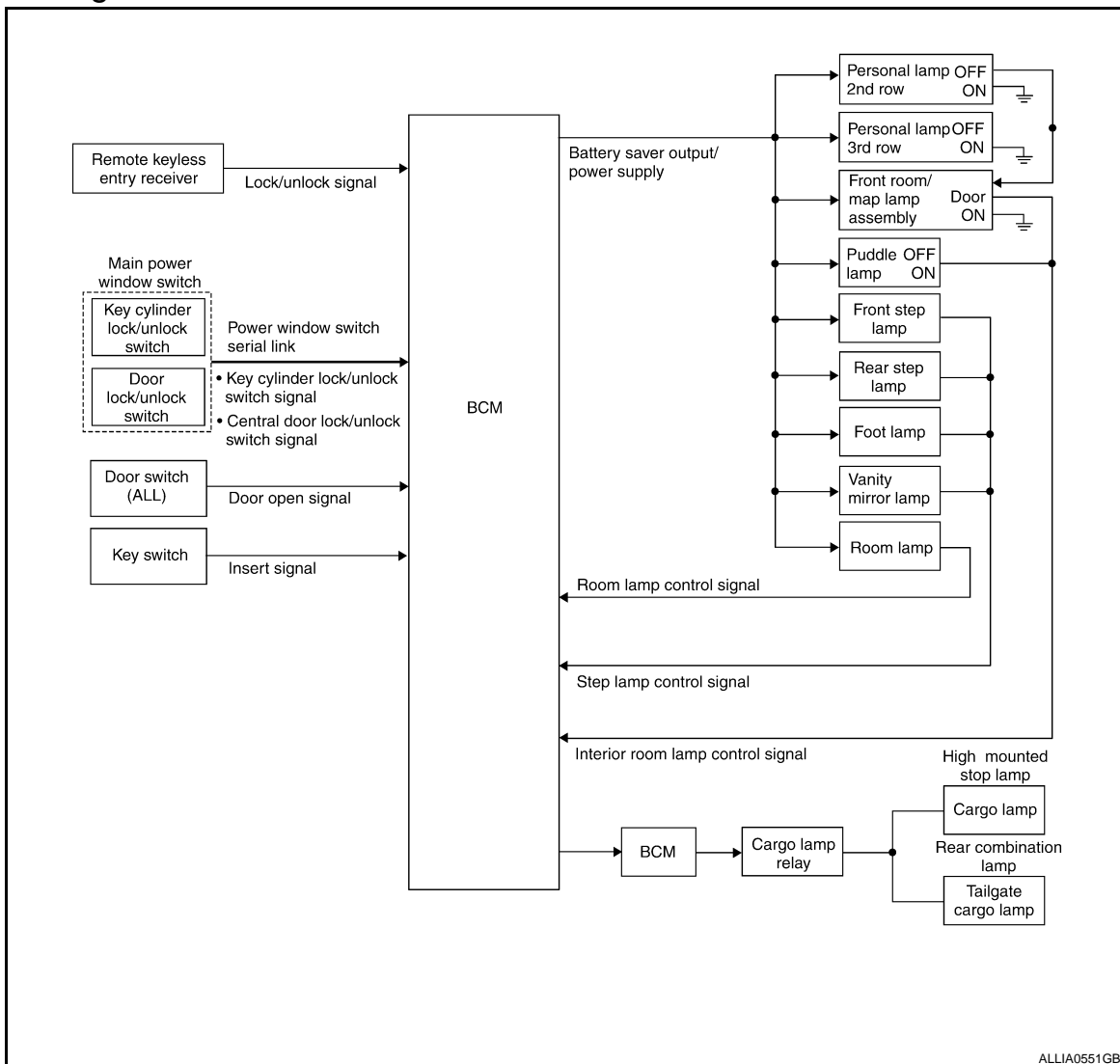

System Description

INFOID:000000001621667

OUTLINE

- Interior room lamps* are controlled by the interior room lamp timer control function of the BCM.
 - *Room lamp, Front room/map lamp assembly (if equipped), personal lamp 2nd row (if equipped and when lamp switch is in DOOR position) and puddle lamps (if equipped).
- Cargo lamp and tailgate cargo lamps (if equipped) are controlled by the cargo lamp control function of the BCM.
- Step lamps* are controlled by the step lamp control function of the BCM.
 - *Front step lamps, rear step lamps and foot lamps (if equipped).

The timer control functions of the BCM activate based on inputs from the remote keyless entry receiver, the door switches, the key switch (column shift), the key switch and key lock solenoid (floor shift or the cargo lamp switch).

ROOM LAMP TIMER OPERATION

When the interior room lamp switch is in the DOOR position and when all conditions below are met, the BCM begins timer control (maximum 30 seconds) for interior room lamp ON/OFF.

INTERIOR ROOM LAMP CONTROL SYSTEM

< FUNCTION DIAGNOSIS >

- When the front door LH is unlocked [with the main power window and door lock/unlock switch, front door lock assembly (key cylinder switch)].
- When the front door LH is unlocked with the remote keyless entry system (if equipped).
- When a door opens → closes and the key is not inserted in the ignition slot.

Timer control is canceled under the following conditions.

- When the front door LH is locked [with the main power window and door lock/unlock switch or front door lock assembly (key cylinder switch)]
- When the front door LH is locked with the remote keyless entry system (if equipped).
- A door is opened (door switch turns ON).
- The ignition switch is turned ON.

Interior lamp operational settings can be changed with the function setting of CONSULT-III.

INTERIOR LAMP BATTERY SAVER CONTROL

If an interior lamp is left ON and does not turn OFF even when the doors are closed, the BCM turns off power to the interior lamps automatically to save the battery 30 minutes after the ignition switch is turned OFF.

The BCM controls power and ground to all interior lamps.

After the battery saver system turns the lamps OFF, the lamps will illuminate again when

- a signal is received from the keyless entry system
- a door is opened or closed
- the key is removed from or inserted into the key slot.

The Interior lamp battery saver control time period can be changed with the function setting of CONSULT-III.

Component Parts Location

INFOID:000000001621668

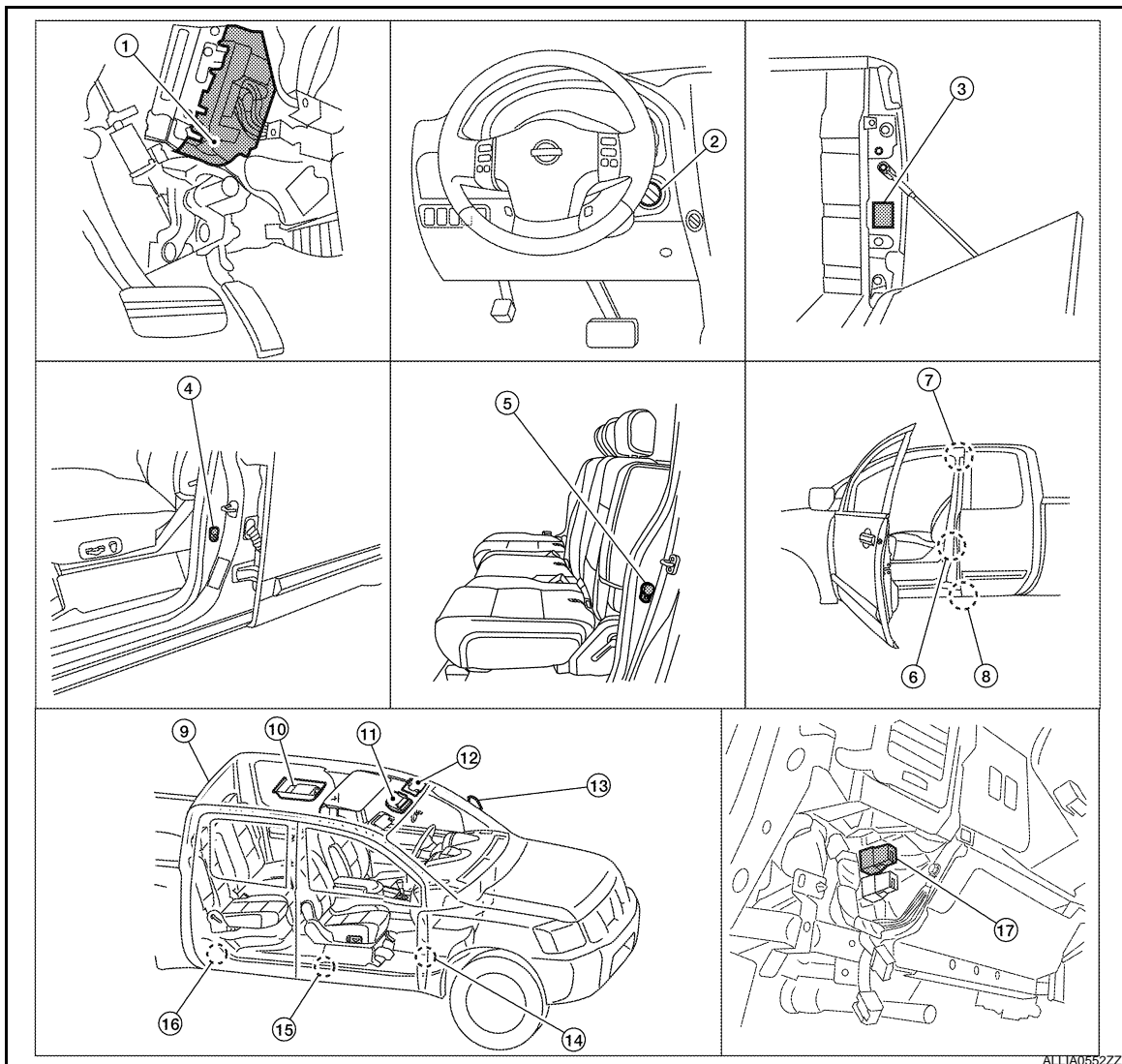

ALLIA0552ZZ

A
B
C
D
E
F
G
H
I
J
K
L
M
N
O
P

INL

INTERIOR ROOM LAMP CONTROL SYSTEM

< FUNCTION DIAGNOSIS >

- | | | |
|--|--|---|
| <p>1. BCM M18, M19, M20 (view with instrument panel removed)</p> <p>4. Front door switch (crew cab)
LH B8
RH B108</p> <p>7. Rear door switch upper (king cab)
LH B73
RH B156</p> <p>10. • Personal lamp 2nd row (with sun-roof) R203
• Room lamp (without front roof console) R9</p> <p>13. Door mirror (puddle lamp)
LH D4
RH D107</p> <p>16. Rear step lamp (crew cab)
LH D206
RH D306</p> | <p>2. • Key switch M80 (column shift)
• Key switch and lock solenoid M27 (floor shift)</p> <p>5. Rear door switch (crew cab)
LH B18
RH B116</p> <p>8. Rear door switch lower (king cab)
LH B74
RH B157</p> <p>11. Front room/map lamp assembly (with front roof console) R102</p> <p>14. Foot lamp
LH M99
RH M100</p> <p>17. Cargo lamp relay M150 (view with lower instrument panel LH removed)</p> | <p>3. Tailgate cargo lamp
LH C13
RH C14</p> <p>6. Front door switch (king cab)
LH B8
RH B108</p> <p>9. Cargo lamp B158</p> <p>12. Vanity lamp
LH R3
RH R8</p> <p>15. Front step lamp
LH D11
LH D109</p> |
|--|--|---|

Component Description

INFOID:000000001621669

Part name	Description
BCM	Provides power and ground and controls timer functions for the interior room lamps, step lamps and cargo lamp.
Key switch (column shift)	Provides key in ignition status to the BCM.
Key switch and lock solenoid (floor shift)	
Door switches	Provides door OPEN/CLOSED status to the BCM.
Cargo lamp switch	Provides cargo lamp ON/OFF request to the BCM.
Power window and door lock/unlock switch RH	Provides door lock/unlock position switch RH status to the BCM.
Main power window and door lock/unlock switch [front door lock assembly LH (key cylinder switch)].	Provides door lock/unlock position switch LH status to the BCM.

ILLUMINATION CONTROL SYSTEM

< FUNCTION DIAGNOSIS >

ILLUMINATION CONTROL SYSTEM

System Diagram

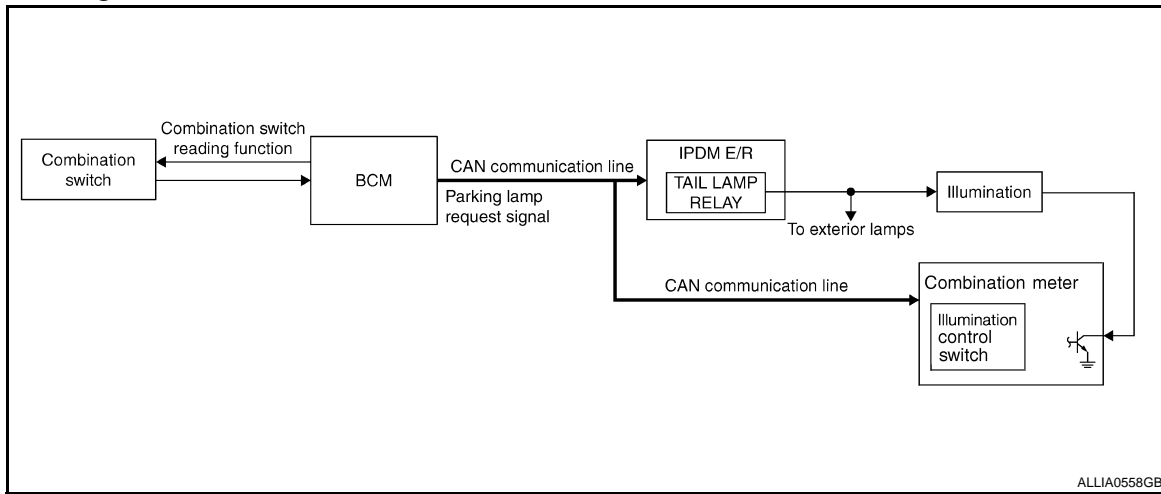

System Description

INFOID:000000001621671

The illumination lamp operation is dependent upon the position of the lighting switch (combination switch). When the lighting switch is placed in the 1ST or 2ND position (or if the auto light system is activated) the BCM (body control module) receives input requesting the parking lamps to illuminate. This input is communicated to the IPDM E/R (intelligent power distribution module engine room) via the CAN communication lines. The CPU (central processing unit) of the IPDM E/R controls the tail lamp relay coil. When energized, this relay directs power to the parking and illumination lamps, which then illuminate.

BATTERY SAVER CONTROL

When the lighting switch (combination switch) is in the 1ST or 2ND position and the ignition switch is turned from ON or ACC to OFF, the battery saver control feature is activated. Under this condition, the illumination lamps remain illuminated for 30 minutes unless the lighting switch position is changed. If the lighting switch position is changed, then the illumination lamps are turned off after a 30 second delay. When the lighting switch is turned from OFF to 1ST or 2ND position (or if auto light system is activated) after illumination lamps have been turned off by the battery saver control, the illumination lamps illuminate again.

Component Parts Location

INFOID:000000001621672

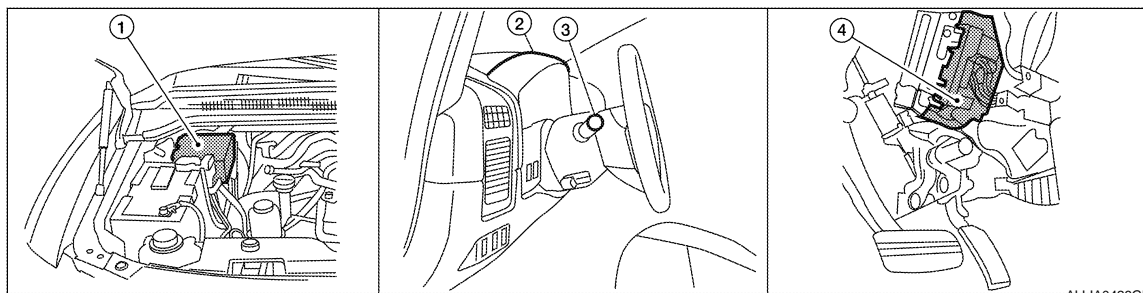

1. IPDM E/R E122, E123, E124
2. Combination meter (illumination control switch) M24, M25
3. Combination switch M28
4. BCM M18, M20 (view with instrument panel removed)

ILLUMINATION CONTROL SYSTEM

< FUNCTION DIAGNOSIS >

Component Description

INFOID:000000001621673

Part name	Description
BCM	The BCM monitors the lighting switch position with the combination switch reading function. The BCM requests, via CAN communication, that the IPDM E/R activate the tail lamp relay.
IPDM E/R	The IPDM E/R activates the tail lamp relay based on inputs received from the BCM via the CAN communication network.
Combination meter (illumination control switch)	The illumination control switch is a part of the combination meter. The combination meter controls illumination intensity by varying ground to the illumination lamps based on the illumination control switch position.
Combination switch	The combination switch provides input to the BCM about the lighting switch position.

DIAGNOSIS SYSTEM (BCM)

< FUNCTION DIAGNOSIS >

DIAGNOSIS SYSTEM (BCM) COMMON ITEM

COMMON ITEM : CONSULT-III Function

INFOID:000000001621674

CONSULT-III can display each diagnostic item using the diagnostic test modes shown following.

BCM diagnostic test item	Diagnostic mode	Description
Inspection by part	WORK SUPPORT	Supports inspections and adjustments. Commands are transmitted to the BCM for setting the status suitable for required operation, input/output signals are received from the BCM and received data is displayed.
	DATA MONITOR	Displays BCM input/output data in real time.
	ACTIVE TEST	Operation of electrical loads can be checked by sending drive signal to them.
	SELF-DIAG RESULTS	Displays BCM self-diagnosis results.
	CAN DIAG SUPPORT MNTR	The result of transmit/receive diagnosis of CAN communication can be read.
	ECU PART NUMBER	BCM part number can be read.
	CONFIGURATION	Performs BCM configuration read/write functions.

INT LAMP

INT LAMP : CONSULT-III Function

INFOID:000000001621675

WORK SUPPORT

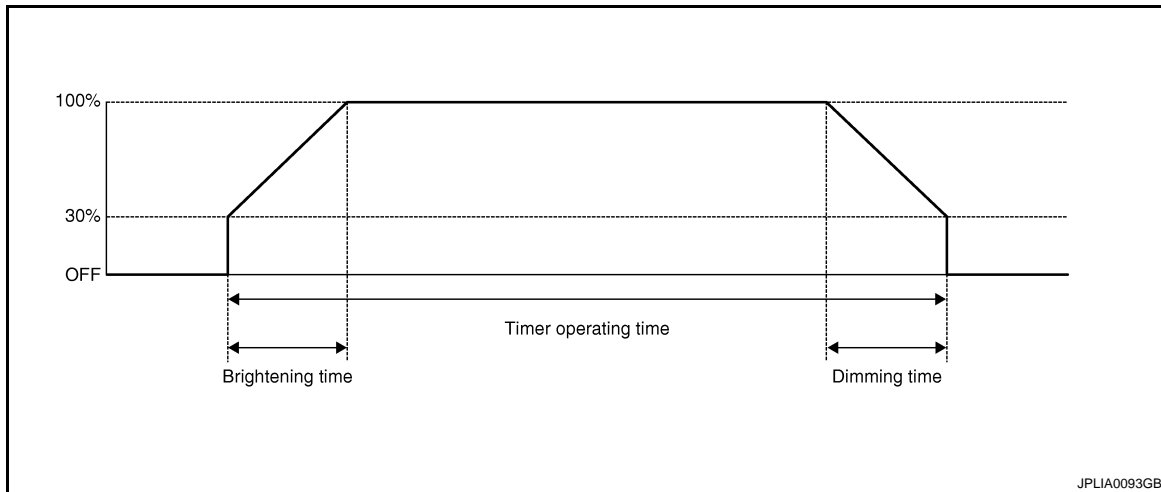

JPLIA0093GB

Service item	Setting item	Setting
SET I/L D-UNLCK INTCON	ON	With the interior room lamp timer function
	OFF	Without the interior room lamp timer function
ROOM LAMP ON TIME SET	MODE 1	0.5 sec.
	MODE 2	1 sec.
	MODE 3	2 sec.
	MODE 4	3 sec.
	MODE 5	4 sec.
	MODE 6	5 sec.
	MODE 7	0 sec.

Sets the interior room lamp gradual brightening time.

DIAGNOSIS SYSTEM (BCM)

< FUNCTION DIAGNOSIS >

Service item	Setting item	Setting
ROOM LAMP OFF TIME SET	MODE 1	0.5 sec.
	MODE 2	1 sec.
	MODE 3	2 sec.
	MODE 4	3 sec.
	MODE 5	4 sec.
	MODE 6	5 sec.
	MODE 7	0 sec.

Sets the interior room lamp gradual dimming time.

DATA MONITOR

Monitor item [Unit]	Description
IGN ON SW [ON/OFF]	The switch status input from ignition switch
KEY ON SW [ON/OFF]	Key switch status input from key slot
DOOR SW-DR [ON/OFF]	The switch status input from front door switch LH
DOOR SW-AS [ON/OFF]	The switch status input from front door switch RH
DOOR SW-RR [ON/OFF]	The switch status input from rear door switch RH
DOOR SW- RL [ON/OFF]	The switch status input from rear door switch LH
BACK DOOR SW [ON/OFF]	Listed, but not monitored
KEY CYL LK-SW [ON/OFF]	Lock switch status received from key cylinder switch by power window serial link
KEY CYL UN-SW [ON/OFF]	Unlock switch status received from key cylinder switch by power window serial link
CDL LOCK SW [ON/OFF]	Lock switch status received from door lock/unlock switch by power window serial link
CDL UNLOCK SW [ON/OFF]	Unlock switch status received from door lock/unlock switch by power window serial link
KEYLESS LOCK [ON/OFF]	Lock signal status received from remote keyless entry receiver
KEYLESS UNLOCK [ON/OFF]	Unlock signal status received from remote keyless entry receiver

ACTIVE TEST

Test item	Operation	Description
INT LAMP	ON	Outputs the interior room lamp control signal to turn the front room/map lamp, personal lamps (Map lamp switch is in DOOR position) and puddle lamps (if equipped) ON.
	OFF	Stops the interior room lamp control signal to turn the front room/map lamp, personal lamps (Map lamp switch is in DOOR position) and puddle lamps (if equipped) OFF.
IGN ILLUM	ON	Outputs the ignition keyhole illumination signal to turn the ignition keyhole illumination ON.
	OFF	Stops the ignition keyhole illumination signal to turn the ignition keyhole illumination OFF.

DIAGNOSIS SYSTEM (BCM)

< FUNCTION DIAGNOSIS >

Test item	Operation	Description
STEP LAMP TEST	ON	Outputs the step lamp control signal to turn the step lamps and foot lamps (if equipped) ON.
	OFF	Stops the step lamp control signal to turn the step lamps and foot lamps (if equipped) OFF.
LUGGAGE LAMP TEST	ON	Outputs the cargo lamp control signal to turn cargo lamp ON.
	OFF	Stops the cargo lamp control signal to turn cargo lamp OFF.

BATTERY SAVER

BATTERY SAVER : CONSULT-III Function

INFOID:000000001621676

WORK SUPPORT

Service item	Setting item	Setting
ROOM LAMP TIMER SET	MODE 1 (ON)	Interior room lamp timer activates with synchronizing all doors.
	MODE 2 (OFF)	Interior room lamp timer activates with synchronizing the front door LH only.

DATA MONITOR

Monitor item [Unit]	Description
IGN ON SW [ON/OFF]	The switch status input from ignition switch
KEY ON SW [ON/OFF]	Key switch status input from key slot
DOOR SW-DR [ON/OFF]	The switch status input from front door switch LH
DOOR SW-AS [ON/OFF]	The switch status input from front door switch RH
DOOR SW-RR [ON/OFF]	The switch status input from rear door switch RH
DOOR SW- RL [ON/OFF]	The switch status input from rear door switch LH
BACK DOOR SW [ON/OFF]	Listed, but not monitored
KEY CYL LK-SW [ON/OFF]	Lock switch status received from key cylinder switch by power window serial link
KEY CYL UN-SW [ON/OFF]	Unlock switch status received from key cylinder switch by power window serial link
CDL LOCK SW [ON/OFF]	Lock switch status received from door lock/unlock switch by power window serial link
CDL UNLOCK SW [ON/OFF]	Unlock switch status received from door lock/unlock switch by power window serial link
KEYLESS LOCK [ON/OFF]	Lock signal status received from remote keyless entry receiver
KEYLESS UNLOCK [ON/OFF]	Unlock signal status received from remote keyless entry receiver

ACTIVE TEST

DIAGNOSIS SYSTEM (BCM)

< FUNCTION DIAGNOSIS >

Test item	Operation	Description
BATTERY SAVER	ON	Outputs the battery saver output/power supply to turn the interior lamps ON.
	OFF	Stops the battery saver output/power supply to turn the interior lamps OFF.

POWER SUPPLY AND GROUND CIRCUIT

< COMPONENT DIAGNOSIS >

COMPONENT DIAGNOSIS

POWER SUPPLY AND GROUND CIRCUIT

BCM

BCM : Inspection Procedure

INFOID:000000001621677

POWER SUPPLY AND GROUND CIRCUIT INSPECTION FOR BCM

For information about power and ground circuit inspection for the BCM, refer to [BCS-29, "Diagnosis Procedure"](#).

A
B
C
D
E
F
G
H
I
J
K
INL
M
N
O
P

BATTERY SAVER OUTPUT/POWER SUPPLY CIRCUIT

< COMPONENT DIAGNOSIS >

BATTERY SAVER OUTPUT/POWER SUPPLY CIRCUIT

Description

INFOID:000000001621678

Provides the battery saver output/power supply. Cuts the power supply when the interior room lamp battery saver is activating.

Component Function Check

INFOID:000000001621679

1. CHECK BATTERY SAVER OUTPUT/POWER SUPPLY FUNCTION

CONSULT-III

1. Turn ignition switch ON.
2. Turn each interior room lamp ON.
 - Front step lamps
 - Rear step lamps (crew cab)
 - Puddle lamps (if equipped)
 - Foot lamps (if equipped)
 - Room lamp (if equipped)
 - Front room/map lamp assembly (if equipped)
 - Vanity lamps (if equipped)
 - Tailgate cargo lamps (if equipped)
 - Personal lamp 2nd row (if equipped)
3. Select "BATTERY SAVER" of BCM (BATTERY SAVER) active test item.
4. While operating the test items, check that each interior room lamp turns ON/OFF.

OFF : Interior room lamp OFF

ON : Interior room lamp ON

Does the interior room lamp turn ON/OFF?

- YES >> Battery saver output/power supply circuit is normal.
NO >> Refer to [INL-16, "Diagnosis Procedure"](#).

Diagnosis Procedure

INFOID:000000001621680

1. CHECK BATTERY SAVER OUTPUT/POWER SUPPLY OUTPUT

CONSULT-III

1. Turn ignition switch ON.
2. Select "BATTERY SAVER" of BCM (BATTERY SAVER) active test item.
3. With test item operating, check voltage between BCM harness connector M20 terminal 56 and ground.

(+)		(-)	Test item	Voltage
Connector	Terminal		BATTERY SAVER	
M20	56	Ground	OFF	0V
			ON	Battery voltage

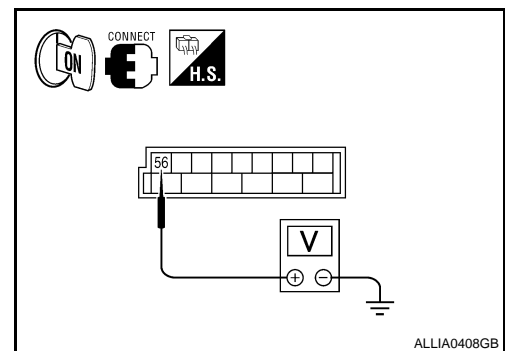

Is the voltage reading as specified?

- YES >> GO TO 2
NO >> Replace BCM. Refer to [BCS-50, "Removal and Installation"](#).

2. CHECK BATTERY SAVER OUTPUT/POWER SUPPLY OPEN CIRCUIT

1. Turn ignition switch OFF.
2. Disconnect the following connectors.
 - BCM M20
 - Front step lamp LH
 - Front step lamp RH
 - Door mirror LH (with puddle lamps)

BATTERY SAVER OUTPUT/POWER SUPPLY CIRCUIT

< COMPONENT DIAGNOSIS >

- Door mirror RH (with puddle lamps)
 - Rear step lamp LH (crew cab)
 - Rear step lamp RH (crew cab)
 - Foot lamp LH (if equipped)
 - Foot lamp RH (if equipped)
 - Room lamp (if equipped)
 - Front room/map lamp assembly (if equipped)
 - Vanity lamp LH (if equipped)
 - Vanity lamp RH (if equipped)
 - Personal lamp 2nd row (if equipped)
3. Check continuity between BCM harness connector and each interior room lamp harness connector.

BCM		Each interior room lamp			Continuity
Connector	Terminal	Connector	Terminal		
M20	56	Front step lamp LH	D11	1	Yes
		Front step lamp RH	D109	1	
		Door mirror LH (with puddle lamps)	D4	12	
		Door mirror RH (with puddle lamps)	D107	12	
		Rear step lamp LH (crew cab)	D206	1	
		Rear step lamp RH (crew cab)	D306	1	
		Foot lamp LH (if equipped)	M99	1	
		Foot lamp RH (if equipped)	M100	1	
		Room lamp (if equipped)	R9	2	
		Front room/map lamp assembly (if equipped)	R102	6	
		Vanity lamp LH (if equipped)	R3	1	
		Vanity lamp RH (if equipped)	R8	1	
		Personal lamp 2nd row (if equipped)	R203	3	

Does continuity exist?

- YES >> GO TO 3
- NO >> Repair the harnesses or connectors.

3.CHECK BATTERY SAVER OUTPUT/POWER SUPPLY SHORT CIRCUIT

Check continuity between BCM harness connector M20 terminal 56 and ground.

Connector	Terminal	—	Continuity
M20	56	Ground	No

Does continuity exist?

- YES >> Repair the harnesses or connectors.
- NO >> Check that each interior room lamp has no internal short circuit.

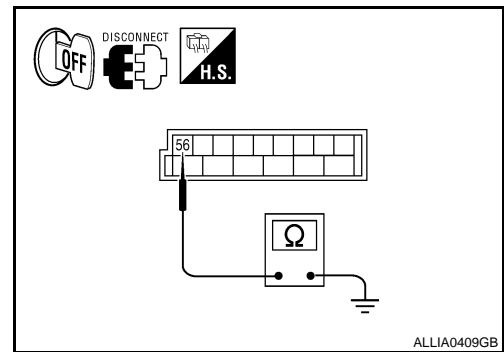

INTERIOR ROOM LAMP CONTROL CIRCUIT

< COMPONENT DIAGNOSIS >

INTERIOR ROOM LAMP CONTROL CIRCUIT

Description

INFOID:000000001621681

Controls the following interior room lamps (ground side) by pulse width modulated signal

- Puddle lamps (if equipped)
- Room lamp (if equipped)
- Front room/map lamp assembly (if equipped)
- Personal lamp 2nd row (if equipped)

NOTE:

PWM signal control period is approximately 250 Hz (in the gradual brightening/dimming).

Component Function Check

INFOID:000000001621682

CAUTION:

Before performing the diagnosis, check that the following is normal.

- Battery saver output/power supply
- Room lamp bulb (if equipped)
- Puddle lamp bulbs (if equipped)
- Front room/map lamp bulbs (if equipped)
- Personal lamp bulbs (if equipped)

1. CHECK INTERIOR ROOM LAMP CONTROL FUNCTION

CONSULT-III

1. Switch the map lamp switch to DOOR.
2. Turn ignition switch ON.
3. Select "INT LAMP" of BCM (INT LAMP) active test item.
4. With the test items operating, check that each interior room lamp turns ON/OFF (gradual brightening/dimming).

ON : Interior room lamp gradual brightening

OFF : Interior room lamp gradual dimming

Do the interior room lamps turn ON/OFF (gradual brightening/dimming)?

YES >> Interior room lamp control circuit is normal.

NO >> Refer to [INL-18, "Diagnosis Procedure"](#).

Diagnosis Procedure

INFOID:000000001621683

1. CHECK INTERIOR ROOM LAMP CONTROL OUTPUT

CONSULT-III

1. Turn ignition switch ON.
2. Select "INT LAMP" of BCM (INT LAMP) active test item.
3. While operating the test item, check voltage between BCM harness connector M20 terminal 63 and ground.

(+)		(-)	INT LAMP	Voltage
Connector	Terminal			
M20	63	Ground	ON	0V
			OFF	Battery voltage

Are voltage readings as specified?

YES >> Interior room lamp control circuit is operating normally.

Fixed ON >> GO TO 3

Fixed OFF >> GO TO 2.

2. CHECK INTERIOR ROOM LAMP CONTROL OPEN CIRCUIT

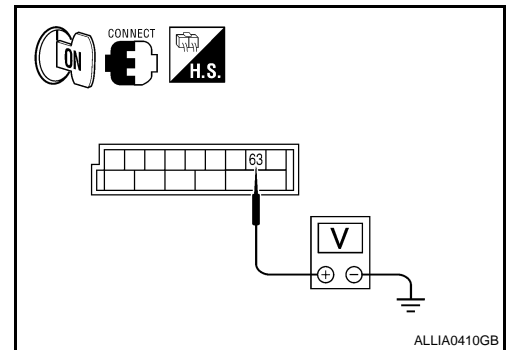

INTERIOR ROOM LAMP CONTROL CIRCUIT

< COMPONENT DIAGNOSIS >

1. Turn ignition switch OFF.
2. Disconnect BCM connector M20, door mirror connectors, room lamp connector or front room/map lamp connector (if equipped).
3. Check continuity between BCM harness connector M20 terminal 63 and the door mirror connectors and front room/map lamp harness connector.

Connector	Terminal	Component	Connector	Terminal	Continuity
A:M20	63	Door mirror LH (puddle lamp)	B:D4	13	Yes
		Door mirror RH (puddle lamp)	B:D107	13	
		Room lamp	C:R9	1	
		Front room/map lamp	D:R102	1	

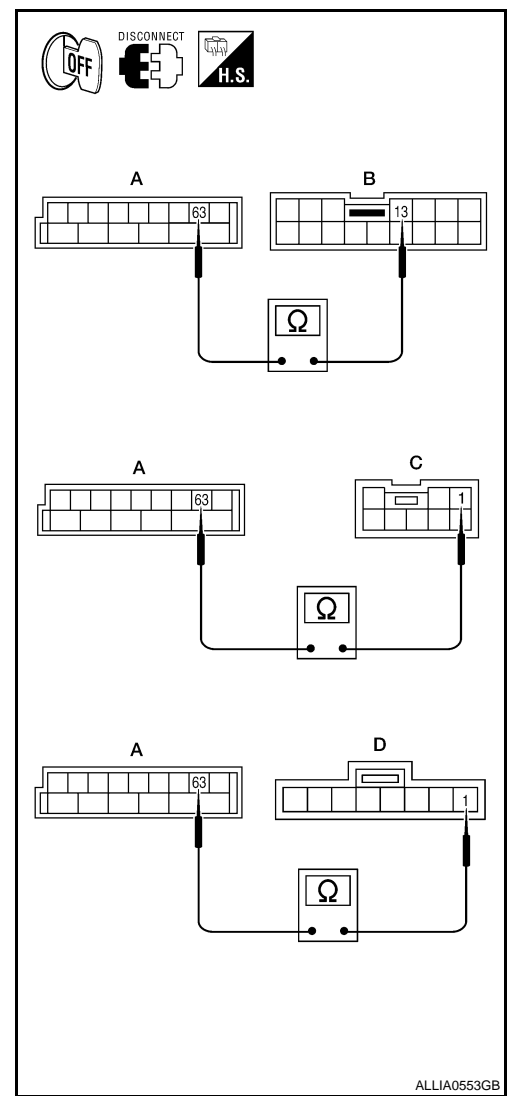

4. If equipped with personal lamp 2nd row, reconnect the front room/map lamp connector R102.
5. Check continuity between BCM harness connector M20 (A) terminal 63 and the 2nd row personal lamp harness connector R203 (B) terminal 1.

A		B		Continuity
Connector	Terminal	Connector	Terminal	
M20	63	R203	1	Yes

Are the continuity test results as specified?

YES >> Replace the room lamp, front room/map lamp, door mirror or personal lamp. Refer to [INL-58, "Removal and Installation"](#).

NO >> Repair the harnesses or connectors.

3. CHECK INTERIOR ROOM LAMP CONTROL SHORT CIRCUIT

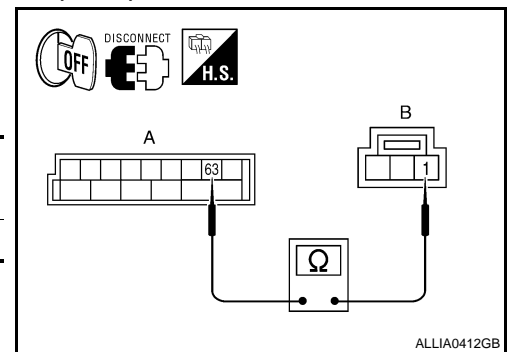

INTERIOR ROOM LAMP CONTROL CIRCUIT

< COMPONENT DIAGNOSIS >

1. Turn ignition switch OFF.
2. Disconnect BCM connector M20, door mirrors and personal lamp 2nd row connectors.
3. Move the room/map lamp switch to the ON position.
4. Check continuity between BCM harness connector and ground.

Connector	Terminal	—	Continuity
M20	63	Ground	No

Does continuity exist?

- YES >> Repair the harnesses or connectors.
NO >> Replace BCM. Refer to [BCS-50. "Removal and Installation"](#).

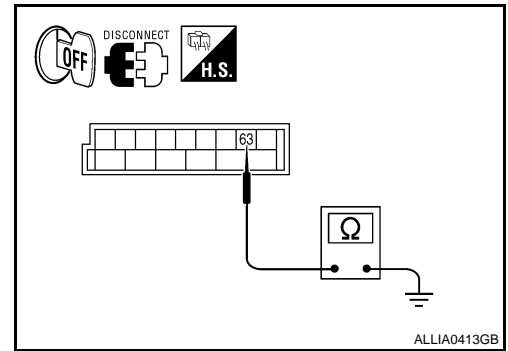

STEP LAMP CIRCUIT

< COMPONENT DIAGNOSIS >

STEP LAMP CIRCUIT

Description

INFOID:000000001621684

Controls the front and rear step lamps and the foot lamps (ground side) to turn the lamps ON and OFF.

Component Function Check

INFOID:000000001621685

CAUTION:

Before performing the diagnosis, check that the following is normal.

- Battery saver output/power supply
- Step lamp and/or foot lamp bulb

1. CHECK STEP LAMP OPERATION

CONSULT-III

1. Turn ignition switch ON.
2. Select "STEP LAMP TEST" of BCM (INT LAMP) active test item.
3. While operating the test items, check that the front/rear step lamps and foot lamps (if equipped) turn ON/OFF.

ON : Step lamp ON

OFF : Step lamp OFF

Do the lamps turn ON/OFF?

YES >> Step lamp circuit is operating.

NO >> Refer to [INL-21, "Diagnosis Procedure"](#).

Diagnosis Procedure

INFOID:000000001621686

1. CHECK STEP LAMP OUTPUT

CONSULT-III

1. Turn ignition switch ON.
2. Select "STEP LAMP TEST" of BCM (INT LAMP) active test item.
3. While operating the test item, check voltage between BCM harness connector and ground.

Connector	Terminal	—	STEP LAMP TEST	Voltage
M20	62	Ground	ON	0V
			OFF	Battery voltage

Are the voltage readings as specified?

YES >> Step lamp control circuit is operating normally.

Fixed ON >> GO TO 3

Fixed OFF >> GO TO 2.

2. CHECK STEP LAMP OPEN CIRCUIT

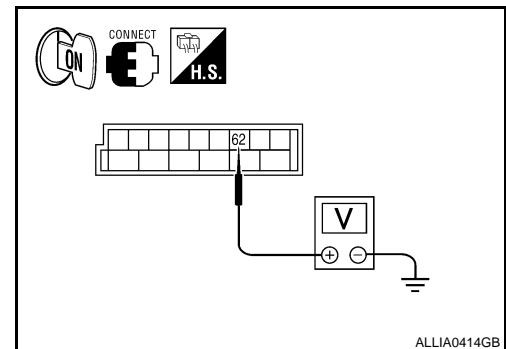

STEP LAMP CIRCUIT

< COMPONENT DIAGNOSIS >

1. Turn ignition switch OFF.
2. Disconnect BCM connector M20 and front step lamp, rear step lamp (if equipped) and foot lamp connectors (if equipped).
3. Check continuity between BCM harness connector, step lamp harness connectors and foot lamp connectors (if equipped).

Connector	Terminal	Connector	Terminal	Continuity	
A:M20	62	Front step lamp LH	B:D11	2	Yes
		Front step lamp RH	B:D109	2	
		Rear step lamp LH (crew cab)	B:D206	2	
		Rear step lamp RH (crew cab)	B:D306	2	
		Foot lamp LH (if equipped)	C:M99	2	
		Foot lamp RH (if equipped)	C:M100	2	

Does continuity exist?

- YES >> Replace lamp. Refer to [INL-58. "Removal and Installation"](#).
- NO >> Repair harnesses or connectors.

3. CHECK STEP LAMP SHORT CIRCUIT

1. Turn ignition switch OFF.
2. Disconnect BCM connector M20 and front step lamp, rear step lamp (if equipped) and foot lamp connectors (if equipped).
3. Check continuity between BCM harness connector M20 terminal 62 and ground.

Connector	Terminal	—	Continuity
M20	62	Ground	No

Does continuity exist?

- YES >> Repair the harnesses or connectors.
- NO >> Replace BCM. Refer to [BCS-50. "Removal and Installation"](#).

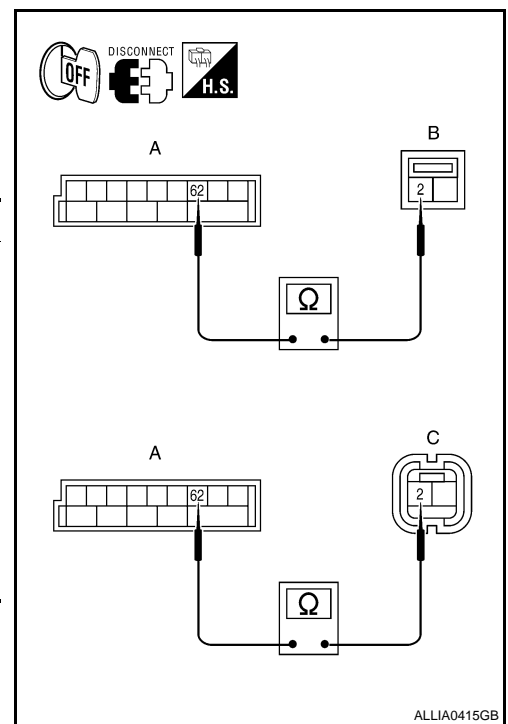

ALLIA0415GB

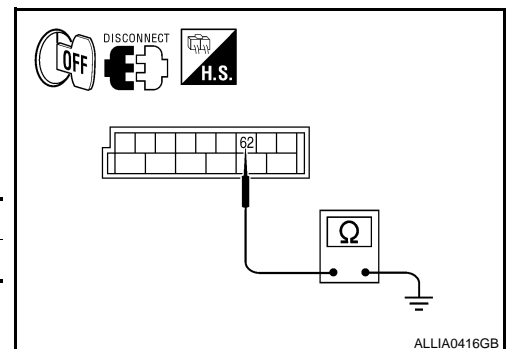

ALLIA0416GB

CARGO LAMP CONTROL CIRCUIT

< COMPONENT DIAGNOSIS >

CARGO LAMP CONTROL CIRCUIT

Description

INFOID:000000001621687

The BCM controls ground to the cargo lamp relay to turn the the cargo lamp and tailgate cargo lamps (if equipped) ON and OFF.

Component Function Check

INFOID:000000001621688

CAUTION:

Before performing the diagnosis, check that the following is normal.

- Battery saver output/power supply
- Cargo lamp bulb
- Tailgate cargo lamp bulbs

1. CHECK CARGO LAMP OPERATION

CONSULT-III

1. Turn ignition switch ON.
2. Select "LUGGAGE LAMP TEST" of BCM (INT LAMP) active test item.
3. With operating the test items, check voltage between cargo lamp relay harness connector M150 terminal 3 and ground.

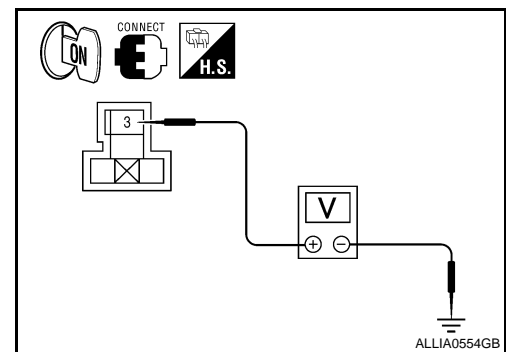

(+) Connector		(-) Terminal	Voltage
M150	3	Ground	Battery voltage

Is battery voltage present?

- YES >> Cargo lamp relay is operating normally.
 NO >> Refer to [INL-23, "Diagnosis Procedure"](#).

Diagnosis Procedure

INFOID:000000001621689

1. CHECK CARGO LAMP RELAY POWER

Check voltage between cargo lamp relay harness connector M150 terminals 2 and 5 and ground.

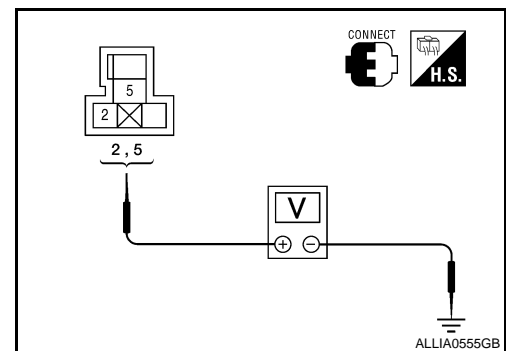

(+) Connector		(-) Terminal	Voltage
M150	2, 5	Ground	Battery voltage

Is battery voltage present?

- YES >> GO TO 2.
 NO >> Check fuse. Repair harness or connector

2. CARGO LAMP RELAY COMPONENT INSPECT

CARGO LAMP CONTROL CIRCUIT

< COMPONENT DIAGNOSIS >

1. Disconnect cargo lamp relay connector M150.
2. Supply power to terminal 2 and ground to terminal 1 of cargo lamp relay.
3. Check continuity between cargo lamp relay terminals 3 and 5.

Terminal	Condition	Continuity	
3	5	Power and ground supplied to terminals 1 and 2	Yes
		No power and ground supplied	No

Are continuity test results as specified?

YES >> GO TO 3.

NO >> Replace the cargo lamp relay.

3. CHECK CARGO LAMP RELAY CONTROL

CONSULT-III

1. Connect cargo lamp relay harness connector M150.
2. Turn ignition switch ON.
3. Select "LUGGAGE LAMP TEST" of BCM (INT LAMP) active test item.
4. While operating the test item, check voltage between the BCM harness connector M19 terminal 50 and ground.

(+)		(-)	LUGGAGE LAMP TEST	Voltage
Connector	Terminal			
M19	50	Ground	ON	0V
			OFF	Battery voltage

Are voltage readings as specified?

YES >> Relay is operating normally.

NO >> GO TO 4.

4. CARGO LAMP RELAY CONTROL CIRCUIT INSPECTION

1. Turn ignition switch OFF.
2. Disconnect BCM connector M19 and cargo lamp relay connector M150.
3. Check continuity between BCM harness connector M19 (A) terminal 50 and cargo lamp relay harness connector M150 (B) terminal 1.

A		B		Continuity
Connector	Terminal	Connector	Terminal	
M19	50	M150	1	Yes

4. Check continuity between BCM harness connector M19 (A) terminal 50 and ground.

A		—	Continuity
Connector	Terminal		
M19	50	Ground	No

Are continuity test results as specified?

YES >> Replace the BCM. Refer to [BCS-50, "Removal and Installation"](#).

NO >> Repair harness or connector.

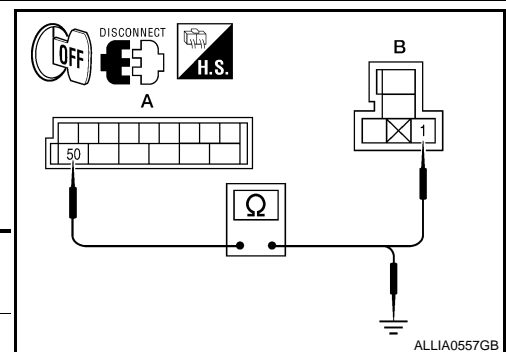
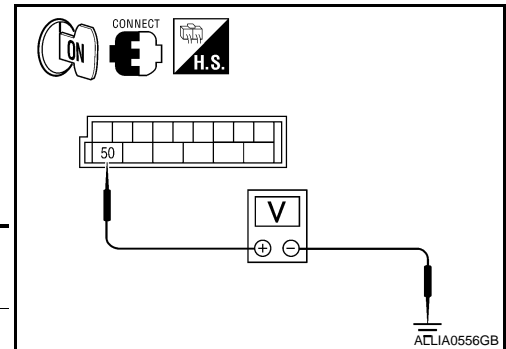
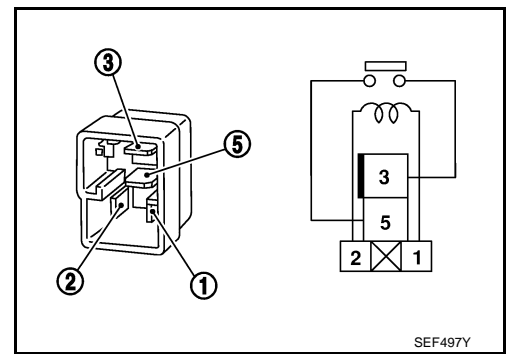

INTERIOR ROOM LAMP CONTROL SYSTEM

< COMPONENT DIAGNOSIS >

INTERIOR ROOM LAMP CONTROL SYSTEM

Wiring Diagram

INFOID:000000001621693

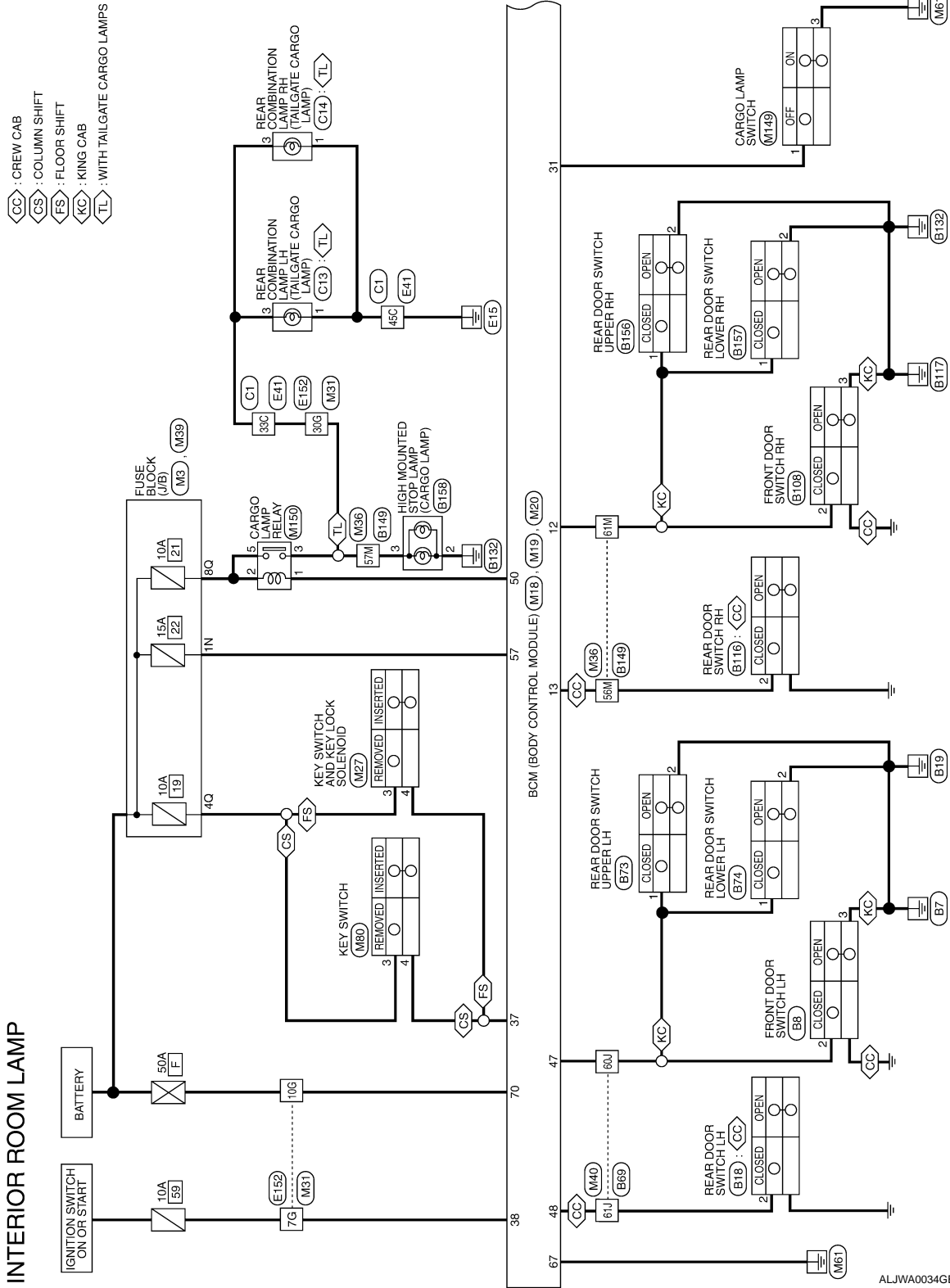

ALJWA0034GB

A
B
C
D
E
F
G
H
I
J
K
L
M
N
O
P

INL

INTERIOR ROOM LAMP CONTROL SYSTEM

< COMPONENT DIAGNOSIS >

INTERIOR ROOM LAMP CONNECTORS

Connector No.	M1
Connector Name	WIRE TO WIRE
Connector Color	WHITE

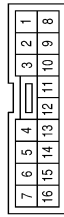

Terminal No.	Color of Wire	Signal Name
10	L	-
13	B	-
14	R	-

Connector No.	M3
Connector Name	FUSE BLOCK (J/B)
Connector Color	WHITE

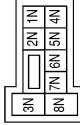

Terminal No.	Color of Wire	Signal Name
1N	Y/R	-

Connector No.	M8
Connector Name	WIRE TO WIRE
Connector Color	WHITE

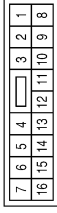

Terminal No.	Color of Wire	Signal Name
6	SHIELD	-
8	G	-
14	B	-

Connector No.	M9
Connector Name	WIRE TO WIRE
Connector Color	WHITE

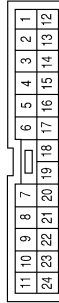

Terminal No.	Color of Wire	Signal Name
6	R/W	-
7	R/G	-

Connector No.	M18
Connector Name	BCM (BODY CONTROL MODULE)
Connector Color	WHITE

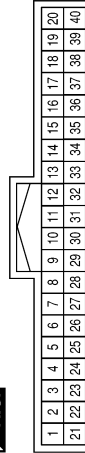

Terminal No.	Color of Wire	Signal Name
12	R/L	DOOR SW (AS)
13	GR	DOOR SW (RR)
22	G	ANTI-LINCH SERIAL LINK (RX, TX)
31	P/L	CARGO_LAMP_SW
37	B/R	KEY SW
38	W/L	IGN SW
39	L	CAN-H
40	P	CAN-L

INTERIOR ROOM LAMP CONTROL SYSTEM

< COMPONENT DIAGNOSIS >

Connector No.	M27
Connector Name	KEY SWITCH AND KEY LOCK SOLENOID
Connector Color	WHITE

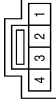

Terminal No.	Color of Wire	Signal Name
3	Y/R	-
4	B/R	-

Connector No.	M20
Connector Name	BCM (BODY CONTROL MODULE)
Connector Color	BLACK



Terminal No.	Color of Wire	Signal Name
56	R/G	BATTERY SAVER OUTPUT
57	Y/R	BAT (FUSE)
62	R/W	STEP LAMP OUTPUT
63	L	ROOM LAMP OUTPUT
67	B	GND (POWER)
70	W/B	BAT (FL)

Connector No.	M19
Connector Name	BCM (BODY CONTROL MODULE)
Connector Color	WHITE

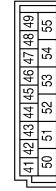

Terminal No.	Color of Wire	Signal Name
47	SB	DOOR SW (DR)
48	R/Y	DOOR SW (RL)
50	R/Y	CARGO - BEDLAMP

Terminal No.	Color of Wire	Signal Name
7G	W/L	-
10G	W/B	-
30G	Y	-

Connector No.	M31
Connector Name	WIRE TO WIRE
Connector Color	WHITE

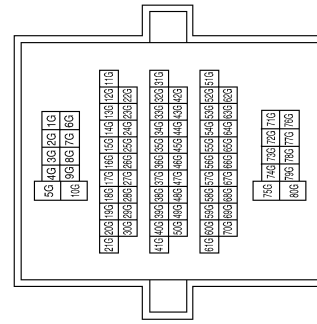

AWLIA0085GB

A
B
C
D
E
F
G
H
I
J
K
L
M
N
O
P

INL

INTERIOR ROOM LAMP CONTROL SYSTEM

< COMPONENT DIAGNOSIS >

Connector No.	M39
Connector Name	FUSE BLOCK (J/B)
Connector Color	WHITE

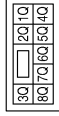

Terminal No.	Color of Wire	Signal Name
4Q	Y/R	-
8Q	G	-

Terminal No.	Color of Wire	Signal Name
49M	R/G	-
50M	R	-
56M	GR	-
57M	LG	-
61M	R/L	-
64M	R/W	-

Connector No.	M36
Connector Name	WIRE TO WIRE
Connector Color	WHITE

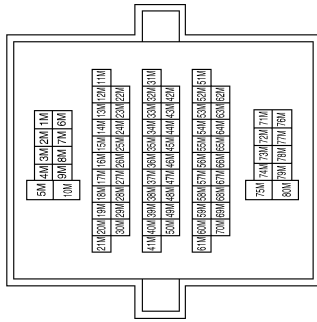

Terminal No.	Color of Wire	Signal Name
58J	R/G	-
59J	R/W	-
60J	SB	-
61J	R/Y	-

Connector No.	M40
Connector Name	WIRE TO WIRE
Connector Color	WHITE

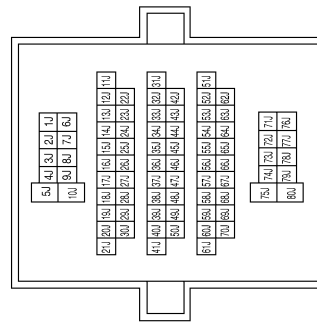

AWLIA0086GB

INTERIOR ROOM LAMP CONTROL SYSTEM

< COMPONENT DIAGNOSIS >

Connector No.	M99
Connector Name	FOOT LAMP LH
Connector Color	BROWN



Terminal No.	Color of Wire	Signal Name
1	R/G	-
2	R/W	-

Connector No.	M75
Connector Name	WIRE TO WIRE
Connector Color	WHITE

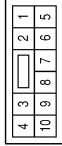

Terminal No.	Color of Wire	Signal Name
3	B	-
6	SHIELD	-
7	G	-

Connector No.	M74
Connector Name	WIRE TO WIRE
Connector Color	BROWN

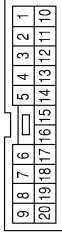

Terminal No.	Color of Wire	Signal Name
4	L	-
6	R/W	-
7	R/G	-

Connector No.	M150
Connector Name	CARGO LAMP RELAY
Connector Color	BLUE



Terminal No.	Color of Wire	Signal Name
1	G	-
2	R/Y	-
3	G	-
5	LG	-

Connector No.	M149
Connector Name	CARGO LAMP SWITCH
Connector Color	WHITE



Terminal No.	Color of Wire	Signal Name
1	P/L	-
2	BR	-
3	B	-
4	R/L	-

Connector No.	M100
Connector Name	FOOT LAMP RH
Connector Color	BROWN



Terminal No.	Color of Wire	Signal Name
1	R/G	-
2	R/W	-

AWLIA0087GB

INTERIOR ROOM LAMP CONTROL SYSTEM

< COMPONENT DIAGNOSIS >

Connector No.	C13
Connector Name	REAR COMBINATION LAMP LH
Connector Color	GRAY

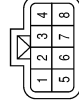

Terminal No.	Color of Wire	Signal Name
1	B	-
3	LG	-

Terminal No.	Color of Wire	Signal Name
33C	LG	-
45C	B	-

Connector No.	C1
Connector Name	WIRE TO WIRE
Connector Color	GRAY

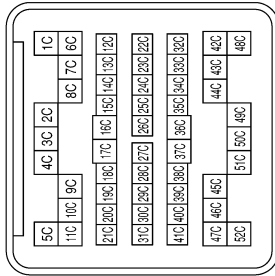

Terminal No.	33C	45C
Color of Wire	LG	B
Signal Name	-	-

Connector No.	E41
Connector Name	WIRE TO WIRE
Connector Color	GRAY

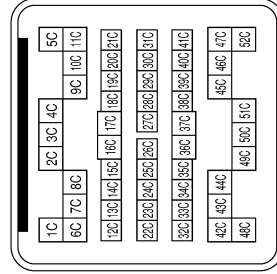

Connector No.	C14
Connector Name	REAR COMBINATION LAMP RH
Connector Color	GRAY

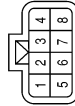

Terminal No.	Color of Wire	Signal Name
1	B	-
3	LG	-

AWLIA0088GB

INTERIOR ROOM LAMP CONTROL SYSTEM

< COMPONENT DIAGNOSIS >

Connector No.	B6
Connector Name	WIRE TO WIRE
Connector Color	WHITE

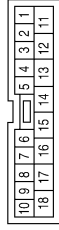

Terminal No.	Color of Wire	Signal Name
9	R/W	-
10	R/G	-

Terminal No.	Color of Wire	Signal Name
7G	L/W	-
10G	W/B	-
30G	Y	-

Connector No.	E152
Connector Name	WIRE TO WIRE
Connector Color	WHITE

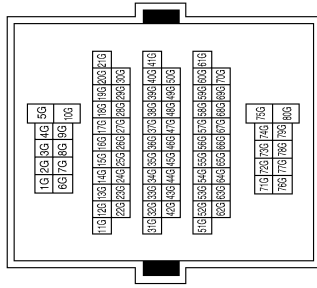

Connector No.	B18
Connector Name	REAR DOOR SWITCH LH
Connector Color	WHITE

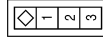

Terminal No.	Color of Wire	Signal Name
2	R/Y	-
3	B	-

Connector No.	B8
Connector Name	FRONT DOOR SWITCH LH
Connector Color	WHITE

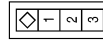

Terminal No.	Color of Wire	Signal Name
2	SB	-
3	B	-

AWLIA0089GB

A
B
C
D
E
F
G
H
I
J
K
L
M
N
O
P

INL

INTERIOR ROOM LAMP CONTROL SYSTEM

< COMPONENT DIAGNOSIS >

Connector No.	B69
Connector Name	WIRE TO WIRE
Connector Color	WHITE

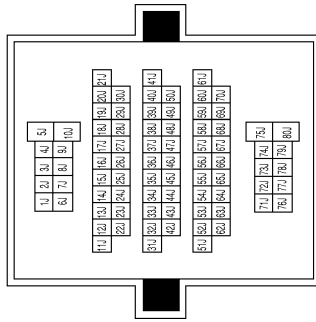

Terminal No.	Color of Wire	Signal Name
58J	R/G	-
59J	R/W	-
60J	SB	-
61J	R/Y	-

Connector No.	B73
Connector Name	REAR DOOR SWITCH UPPER LH
Connector Color	BLACK



Terminal No.	Color of Wire	Signal Name
1	SB	-
2	B	-

Connector No.	B74
Connector Name	REAR DOOR SWITCH LOWER LH
Connector Color	BLACK



Terminal No.	Color of Wire	Signal Name
1	SB	-
2	B	-

Connector No.	B106
Connector Name	WIRE TO WIRE
Connector Color	WHITE

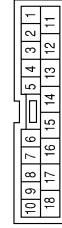

Terminal No.	Color of Wire	Signal Name
9	R/W	-
10	R/G	-

Connector No.	B108
Connector Name	FRONT DOOR SWITCH RH
Connector Color	WHITE

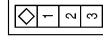

Terminal No.	Color of Wire	Signal Name
2	R/L	-
3	B	-

INTERIOR ROOM LAMP CONTROL SYSTEM

< COMPONENT DIAGNOSIS >

Connector No.	B149
Connector Name	WIRE TO WIRE
Connector Color	WHITE

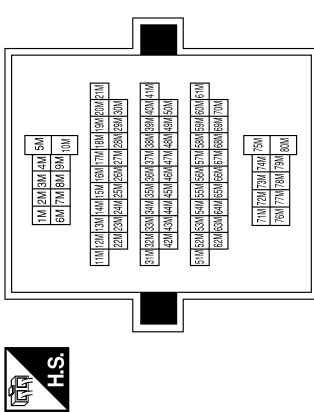

Terminal No.	Color of Wire	Signal Name
49M	R/G	-
50M	R	-
56M	GR	-
57M	LG	-
61M	R/L	-
64M	R/W	-

Connector No.	B146
Connector Name	WIRE TO WIRE
Connector Color	BROWN

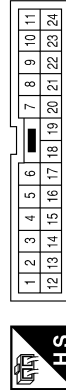

Terminal No.	Color of Wire	Signal Name
1	B	-
5	R/G	-
6	R	-

Connector No.	B116
Connector Name	REAR DOOR SWITCH RH
Connector Color	WHITE

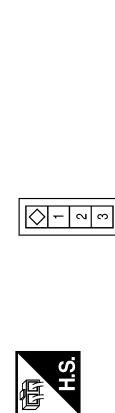

Terminal No.	Color of Wire	Signal Name
2	GR	-
3	B	-

Connector No.	B158
Connector Name	HIGH MOUNTED STOP LAMP
Connector Color	WHITE

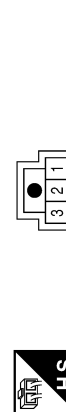

Terminal No.	Color of Wire	Signal Name
2	B	-
3	LG	-

Connector No.	B157
Connector Name	REAR DOOR SWITCH LOWER RH
Connector Color	BLACK



Terminal No.	Color of Wire	Signal Name
1	R/L	-
2	B	-

Connector No.	B156
Connector Name	REAR DOOR SWITCH UPPER RH
Connector Color	BLACK



Terminal No.	Color of Wire	Signal Name
1	R/L	-
2	B	-

AWLIA0091GB



INTERIOR ROOM LAMP CONTROL SYSTEM

< COMPONENT DIAGNOSIS >

Connector No.	D4
Connector Name	DOOR MIRROR LH (WITH AUTOMATIC DRIVE POSITIONER)
Connector Color	WHITE

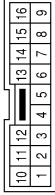
Terminal No.	Color of Wire	Signal Name
12	R/G	-
13	L	-

Connector No.	D2
Connector Name	WIRE TO WIRE
Connector Color	WHITE

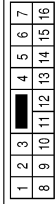

Terminal No.	Color of Wire	Signal Name
8	LG/W	-
14	B	-

Connector No.	D1
Connector Name	WIRE TO WIRE
Connector Color	BROWN

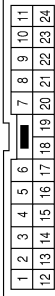
Terminal No.	Color of Wire	Signal Name
6	R/W	-
7	R/G	-
24	L	-

Connector No.	D8
Connector Name	MAIN POWER WINDOW AND DOOR LOCK/UNLOCK SWITCH
Connector Color	WHITE



Terminal No.	Color of Wire	Signal Name
17	B	GND

Connector No.	D7
Connector Name	MAIN POWER WINDOW AND DOOR LOCK/UNLOCK SWITCH (CREW CAB)
Connector Color	WHITE

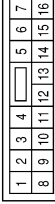
Terminal No.	Color of Wire	Signal Name
4	L	LOCK
6	R	UNLOCK
14	LG/W	ANTI_PINCH SERIAL_LINK

Connector No.	D7
Connector Name	MAIN POWER WINDOW AND DOOR LOCK/UNLOCK SWITCH (KING CAB)
Connector Color	WHITE

Terminal No.	Color of Wire	Signal Name
6	L	-
7	R	-
12	LG/W	-
15	B	-

AWLIA0092GB

INTERIOR ROOM LAMP CONTROL SYSTEM

< COMPONENT DIAGNOSIS >

Connector No.	D101
Connector Name	WIRE TO WIRE
Connector Color	WHITE

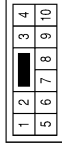

Terminal No.	Color of Wire	Signal Name
3	B	-
6	SHIELD	-
7	LG/W	-

Connector No.	D14
Connector Name	FRONT DOOR LOCK ASSEMBLY LH
Connector Color	BLACK

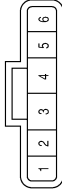

Terminal No.	Color of Wire	Signal Name
1	L	LOCK
5	B	GND
6	R	UNLOCK

Connector No.	D11
Connector Name	FRONT STEP LAMP LH
Connector Color	WHITE



Terminal No.	Color of Wire	Signal Name
1	R/G	-
2	R/W	-

Connector No.	D107
Connector Name	DOOR MIRROR RH (WITH AUTOMATIC DRIVE POSITIONER)
Connector Color	WHITE

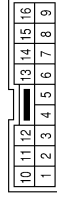

Terminal No.	Color of Wire	Signal Name
12	R/G	-
13	L	-

Connector No.	D105
Connector Name	POWER WINDOW AND DOOR LOCK/UNLOCK SWITCH RH
Connector Color	WHITE

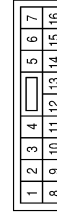

Terminal No.	Color of Wire	Signal Name
11	B	GND
16	LG/W	ANTI_PINCH_SERIAL_LINK

Connector No.	D102
Connector Name	WIRE TO WIRE
Connector Color	BROWN

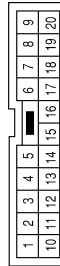

Terminal No.	Color of Wire	Signal Name
4	L	-
6	R/W	-
7	R/G	-

AWLIA0093GB

INTERIOR ROOM LAMP CONTROL SYSTEM

< COMPONENT DIAGNOSIS >

Connector No.	D206
Connector Name	REAR STEP LAMP LH
Connector Color	WHITE



Terminal No.	Color of Wire	Signal Name
1	R/G	-
2	R/W	-

Connector No.	D201
Connector Name	WIRE TO WIRE
Connector Color	WHITE

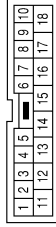

Terminal No.	Color of Wire	Signal Name
9	R/W	-
10	R/G	-

Connector No.	D109
Connector Name	FRONT STEP LAMP RH
Connector Color	WHITE



Terminal No.	Color of Wire	Signal Name
1	R/G	-
2	R/W	-

Connector No.	R1
Connector Name	WIRE TO WIRE
Connector Color	WHITE



Terminal No.	Color of Wire	Signal Name
10	L	-
12	R/G	-
13	B	-
14	R	-

Connector No.	D306
Connector Name	REAR STEP LAMP RH
Connector Color	WHITE



Terminal No.	Color of Wire	Signal Name
1	R/G	-
2	R/W	-

Connector No.	D301
Connector Name	WIRE TO WIRE
Connector Color	WHITE

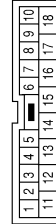

Terminal No.	Color of Wire	Signal Name
9	R/W	-
10	R/G	-

AWLIA0094GB

INTERIOR ROOM LAMP CONTROL SYSTEM

< COMPONENT DIAGNOSIS >

Connector No.	R8
Connector Name	VANITY LAMP RH
Connector Color	WHITE



Terminal No.	Color of Wire	Signal Name
1	R/G	-
2	B	-

Connector No.	R6
Connector Name	WIRE TO WIRE
Connector Color	WHITE

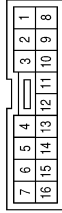

Terminal No.	Color of Wire	Signal Name
1	L/W	-
3	R/G	-
5	L	-
10	B	-

Connector No.	R3
Connector Name	VANITY LAMP LH
Connector Color	WHITE



Terminal No.	Color of Wire	Signal Name
1	R/G	-
2	B	-

Connector No.	R201
Connector Name	WIRE TO WIRE
Connector Color	BROWN

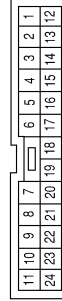

Terminal No.	Color of Wire	Signal Name
1	B	-
5	R/G	-
6	R	-

Connector No.	R102
Connector Name	FRONT ROOM/MAP LAMP ASSEMBLY
Connector Color	GRAY

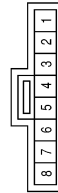

Terminal No.	Color of Wire	Signal Name
1	L	-
2	R	-
5	B	-
6	R/G	-

Connector No.	R101
Connector Name	WIRE TO WIRE
Connector Color	WHITE

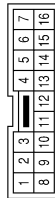

Terminal No.	Color of Wire	Signal Name
1	L/W	-
3	R/G	-
5	L	-
10	B	-

AWLIA0095GB

INTERIOR ROOM LAMP CONTROL SYSTEM

< COMPONENT DIAGNOSIS >

Connector No.	R203
Connector Name	PERSONAL LAMP 2ND ROW
Connector Color	WHITE



Terminal No.	Color of Wire	Signal Name
1	R	-
2	B	-
3	R/G	-

AWLIA0096GB

ILLUMINATION

< COMPONENT DIAGNOSIS >

ILLUMINATION

Wiring Diagram

INFOID:000000001621694

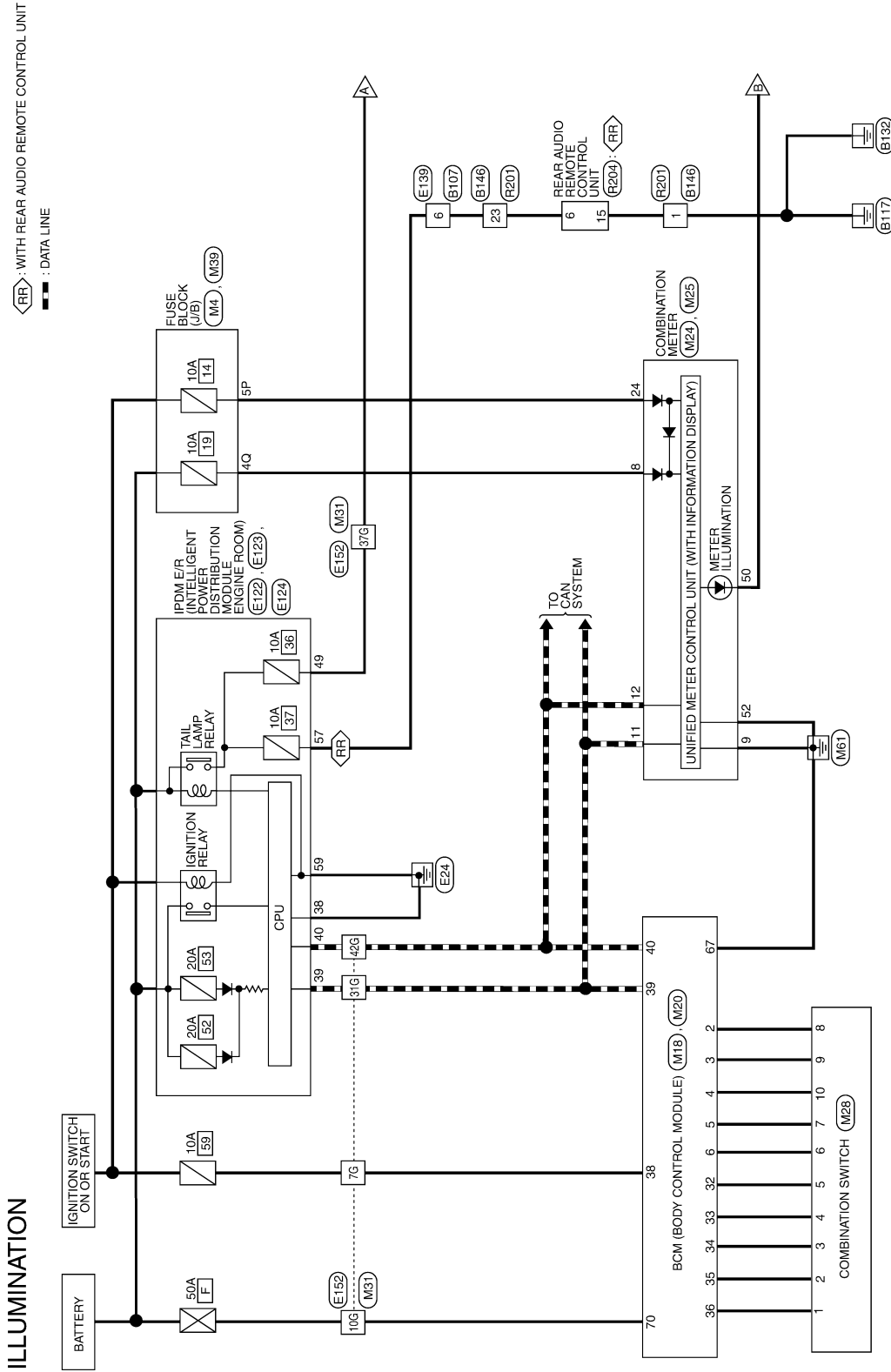

A
B
C
D
E
F
G
H
I
J
K
L
M
N
O
P

INL

ALJWA0037GB

ILLUMINATION

< COMPONENT DIAGNOSIS >

- ◀4W▶ : WITH 4-WHEEL DRIVE
- ◀BA▶ : WITH BASE AUDIO SYSTEM
- ◀EB▶ : EXCEPT BASE AUDIO SYSTEM
- ◀FA▶ : FRONT AIR CONTROL WITH DISPLAY
- ◀PM▶ : WITH POWER OUTSIDE MIRRORS
- ◀SO▶ : WITH REAR SONAR SYSTEM
- ◀WD▶ : WITH DVD ENTERTAINMENT SYSTEM
- ◀XC▶ : FRONT AIR CONTROL WITHOUT DISPLAY
- ★1 : FA : 8
- ★1 : XC : 23
- ★2 : FA : 9
- ★2 : XC : 24
- ★3 : EB : 8
- ★3 : BA : 9
- ★4 : EB : 7
- ★4 : BA : 8

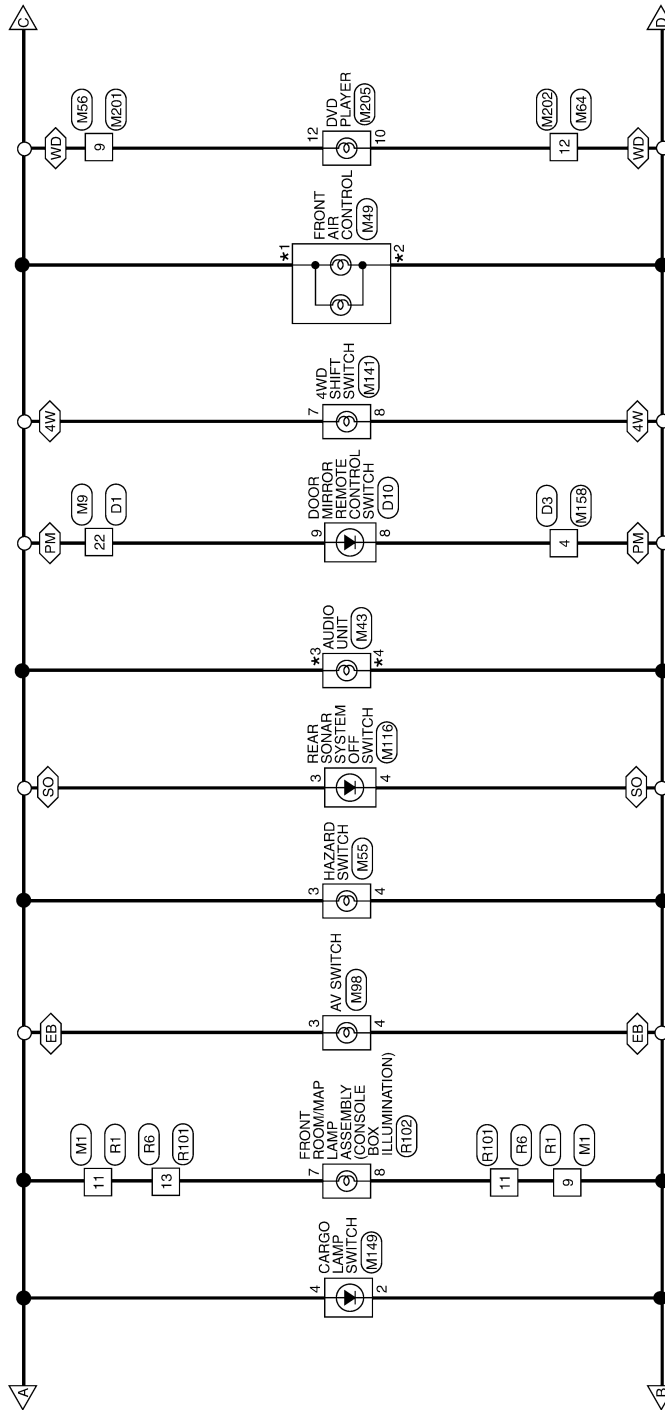

ALJWA0038GB

ILLUMINATION

< COMPONENT DIAGNOSIS >

- AN: WITH BASE AUDIO SYSTEM
- DG: WITH REAR POWER DROP GLASS
- FS: FLOOR SHIFT
- GB: WITH GLOVE BOX LAMP
- HS: WITH HEATED SEATS
- NV: WITH NAVI
- TT: WITH TRAILER TOW
- WV: WITH VDC

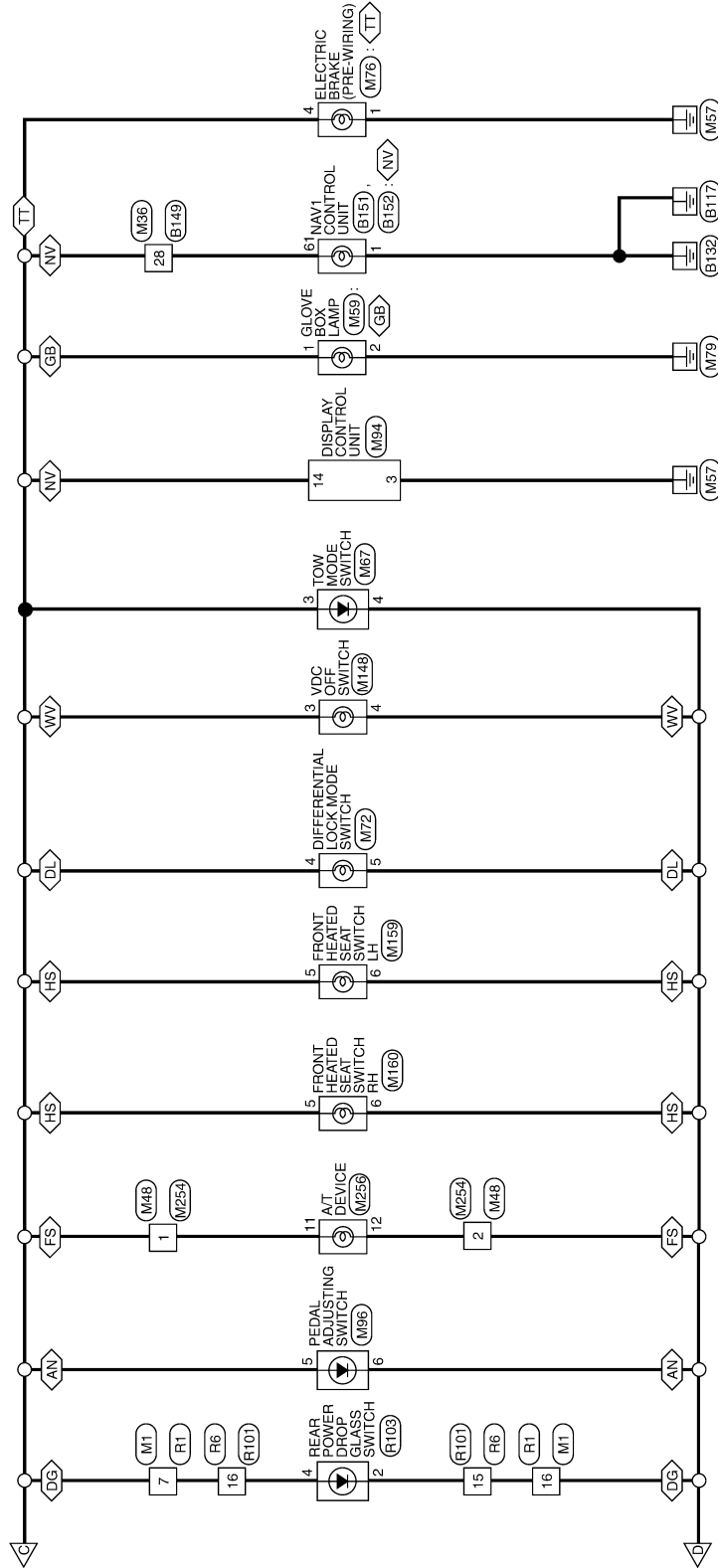

ALJWA0039GB

A
B
C
D
E
F
G
H
I
J
K
INL
M
N
O
P

ILLUMINATION CONNECTORS

Connector No.	M1
Connector Name	WIRE TO WIRE
Connector Color	WHITE

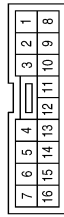

Terminal No.	Color of Wire	Signal Name
7	R/L	-
9	BR	-
11	R/L	-
16	BR	-

Connector No.	M4
Connector Name	FUSE BLOCK (J/B)
Connector Color	WHITE

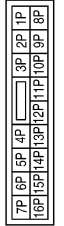

Terminal No.	Color of Wire	Signal Name
5P	O/L	-

Connector No.	M9
Connector Name	WIRE TO WIRE
Connector Color	WHITE

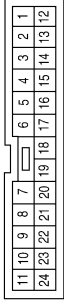

Terminal No.	Color of Wire	Signal Name
22	R/L	-

Connector No.	M18
Connector Name	BCM (BODY CONTROL MODULE)
Connector Color	WHITE

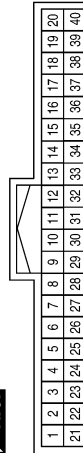

Terminal No.	Color of Wire	Signal Name
2	SB	INPUT-5
3	G/Y	INPUT-4
4	Y	INPUT-3
5	G/B	INPUT-2
6	V	INPUT-1
32	R/G	OUTPUT-5
33	R/Y	OUTPUT-4
34	L	OUTPUT-3
35	O/B	OUTPUT-2
36	R/W	OUTPUT-1
38	W/L	IGN SW
39	L	CAN-H
40	P	CAN-L

Connector No.	M20
Connector Name	BCM (BODY CONTROL MODULE)
Connector Color	BLACK

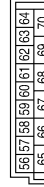

Terminal No.	Color of Wire	Signal Name
67	B	GND (POWER)
70	W/B	BAT (FL)

ILLUMINATION

< COMPONENT DIAGNOSIS >

Connector No.	M28
Connector Name	COMBINATION SWITCH
Connector Color	WHITE

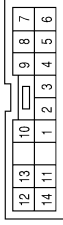

Terminal No.	Color of Wire	Signal Name
1	R/W	-
2	O/B	-
3	L	-
4	R/Y	-
5	R/G	-
6	V	-
7	G/B	-
8	SB	-
9	G/Y	-
10	Y	-

Connector No.	M25
Connector Name	COMBINATION METER
Connector Color	WHITE

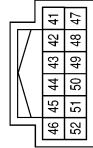

Terminal No.	Color of Wire	Signal Name
50	BR	-
52	B	-

Connector No.	M24
Connector Name	COMBINATION METER
Connector Color	WHITE

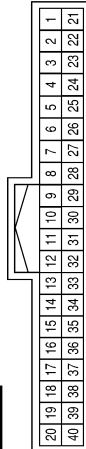

Terminal No.	Color of Wire	Signal Name
8	Y/R	-
9	B	-
11	L	CAN-H
12	P	CAN-L
24	O/L	-

Connector No.	M36
Connector Name	WIRE TO WIRE
Connector Color	WHITE

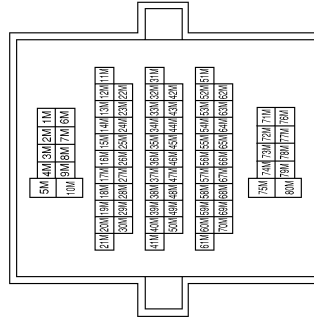

Terminal No.	Color of Wire	Signal Name
28M	R/L	-

Terminal No.	Color of Wire	Signal Name
7G	W/L	-
10G	W/B	-
31G	L	-
37G	R/L	-
42G	P	-

Connector No.	M31
Connector Name	WIRE TO WIRE
Connector Color	WHITE

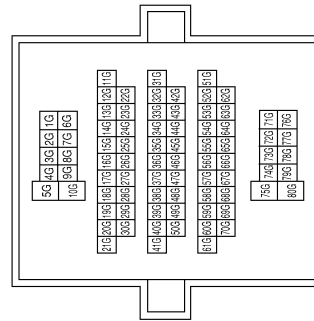

AWLIA0098GB

A
B
C
D
E
F
G
H
I
J
K
L
M
N
O
P

INL

ILLUMINATION

< COMPONENT DIAGNOSIS >

Connector No.	M39
Connector Name	FUSE BLOCK (J/B)
Connector Color	WHITE

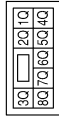

Terminal No.	Color of Wire	Signal Name
4Q	Y/R	-

Connector No.	M43
Connector Name	AUDIO UNIT (BASE AUDIO SYSTEM)
Connector Color	WHITE

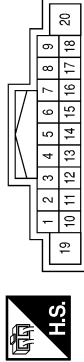

Terminal No.	Color of Wire	Signal Name
8	BR	-
9	R/L	-

Connector No.	M43
Connector Name	AUDIO UNIT (MID AUDIO SYSTEM) (PREMIUM AUDIO SYSTEM)
Connector Color	WHITE

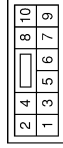

Terminal No.	Color of Wire	Signal Name
7	BR	-
8	R/L	-

Connector No.	M48
Connector Name	WIRE TO WIRE
Connector Color	BROWN



Terminal No.	Color of Wire	Signal Name
1	R/L	ILL
2	BR	GND

Connector No.	M49
Connector Name	FRONT AIR CONTROL (3 CONTROL DIAL SYSTEM)
Connector Color	BLACK

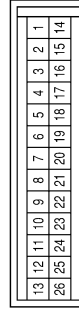

Terminal No.	Color of Wire	Signal Name
23	R/L	ILL
24	BR	GND

Connector No.	M49
Connector Name	FRONT AIR CONTROL (2 CONTROL DIAL SYSTEM)
Connector Color	BLACK

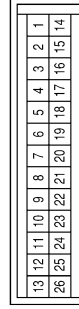

Terminal No.	Color of Wire	Signal Name
8	R/L	ILL
9	BR	GND

AWLIA0099GB

ILLUMINATION

< COMPONENT DIAGNOSIS >

Connector No.	M56
Connector Name	WIRE TO WIRE
Connector Color	WHITE

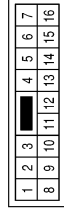

Terminal No.	9	Color of Wire	R/L	Signal Name	-
--------------	---	---------------	-----	-------------	---

Connector No.	M55
Connector Name	HAZARD SWITCH (WITH 3 CONTROL DIAL SYSTEM)
Connector Color	WHITE

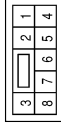

Terminal No.	7	Color of Wire	R/L	Signal Name	-
8	BR	BR	BR	-	-

Connector No.	M55
Connector Name	HAZARD SWITCH (WITH 2 CONTROL DIAL SYSTEM)
Connector Color	WHITE

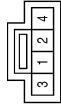

Terminal No.	3	Color of Wire	R/L	Signal Name	-
4	BR	BR	BR	-	-

Connector No.	M67
Connector Name	TOW MODE SWITCH
Connector Color	GRAY



Terminal No.	3	Color of Wire	R/L	Signal Name	-
4	BR	BR	BR	-	-

Connector No.	M64
Connector Name	WIRE TO WIRE
Connector Color	BROWN

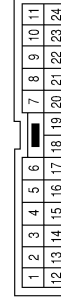

Terminal No.	12	Color of Wire	BR	Signal Name	-
--------------	----	---------------	----	-------------	---

Connector No.	M59
Connector Name	GLOVE BOX LAMP
Connector Color	BROWN



Terminal No.	1	Color of Wire	R/L	Signal Name	-
2	B	B	B	-	-

AWLIA0100GB

ILLUMINATION

< COMPONENT DIAGNOSIS >

Connector No.	M80
Connector Name	KEY SWITCH
Connector Color	WHITE



Terminal No.	Color of Wire	Signal Name
3	Y/R	-
4	B/R	-

Connector No.	M76
Connector Name	ELECTRIC BRAKE (PRE-WIRING)
Connector Color	WHITE

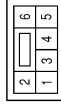

Terminal No.	Color of Wire	Signal Name
1	B	GND
4	R/L	ILL (TAIL)

Connector No.	M72
Connector Name	DIFFERENTIAL LOCK MODE SWITCH
Connector Color	WHITE

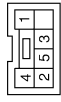

Terminal No.	Color of Wire	Signal Name
4	R/L	-
5	BR	-

Connector No.	M98
Connector Name	AV SWITCH
Connector Color	WHITE

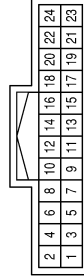

Terminal No.	Color of Wire	Signal Name
3	R/L	ILL
4	BR	ILL CONT GND

Connector No.	M96
Connector Name	PEDAL ADJUSTING SWITCH
Connector Color	BROWN

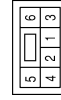

Terminal No.	Color of Wire	Signal Name
5	R/L	-
6	BR	-

Connector No.	M94
Connector Name	DISPLAY CONTROL UNIT
Connector Color	WHITE

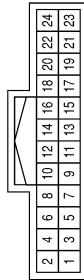

Terminal No.	Color of Wire	Signal Name
3	B	-
14	R/L	-

AWLIA0101GB

ILLUMINATION

< COMPONENT DIAGNOSIS >

Connector No.	M148
Connector Name	VDC OFF SWITCH
Connector Color	GRAY



Terminal No.	Color of Wire	Signal Name
3	R/L	-
4	BR	-

Connector No.	M141
Connector Name	4WD SHIFT SWITCH
Connector Color	WHITE

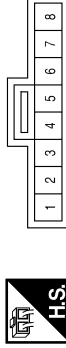

Terminal No.	Color of Wire	Signal Name
7	R/L	-
8	BR	-

Connector No.	M116
Connector Name	REAR SONAR SYSTEM OFF SWITCH
Connector Color	GRAY



Terminal No.	Color of Wire	Signal Name
3	R/L	-
4	BR	-

Connector No.	M159
Connector Name	FRONT HEATED SEAT SWITCH LH
Connector Color	WHITE



Terminal No.	Color of Wire	Signal Name
5	R/L	-
6	BR	-

Connector No.	M158
Connector Name	WIRE TO WIRE
Connector Color	WHITE



Terminal No.	Color of Wire	Signal Name
4	BR	-

Connector No.	M149
Connector Name	CARGO LAMP SWITCH
Connector Color	WHITE



Terminal No.	Color of Wire	Signal Name
2	BR	-
4	R/L	-

AWLIA0102GB

A
B
C
D
E
F
G
H
I
J
K
L
M
N
O
P

INL

ILLUMINATION

< COMPONENT DIAGNOSIS >

Connector No.	M160
Connector Name	FRONT HEATED SEAT SWITCH RH
Connector Color	BROWN

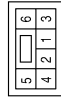

Terminal No.	Color of Wire	Signal Name
5	R/L	-
6	BR	-

Connector No.	M201
Connector Name	WIRE TO WIRE
Connector Color	WHITE

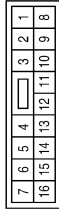

Terminal No.	Color of Wire	Signal Name
9	R/L	-

Connector No.	M202
Connector Name	WIRE TO WIRE
Connector Color	BROWN

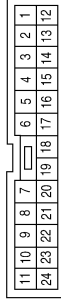

Terminal No.	Color of Wire	Signal Name
12	BR	-

Connector No.	M205
Connector Name	DVD PLAYER
Connector Color	GRAY

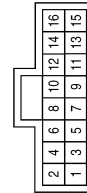

Terminal No.	Color of Wire	Signal Name
10	BR	ILL+
12	R/L	LIGHTING SW

Connector No.	M254
Connector Name	WIRE TO WIRE
Connector Color	BROWN



Terminal No.	Color of Wire	Signal Name
1	R/L	ILL
2	BR	GND

Connector No.	M256
Connector Name	AT DEVICE
Connector Color	BLACK



Terminal No.	Color of Wire	Signal Name
11	R/L	-
12	BR	-

ILLUMINATION

< COMPONENT DIAGNOSIS >

Connector No.	E124
Connector Name	IPDM E/R (INTELLIGENT POWER DISTRIBUTION MODULE ENGINE ROOM)
Connector Color	BLACK



Terminal No.	Color of Wire	Signal Name
57	R/L	TAIL LAMP
59	B	GND (PWR)

Connector No.	E123
Connector Name	IPDM E/R (INTELLIGENT POWER DISTRIBUTION MODULE ENGINE ROOM)
Connector Color	BROWN

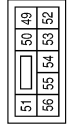

Terminal No.	Color of Wire	Signal Name
49	R/L	ILLUMINATION

Connector No.	E122
Connector Name	IPDM E/R (INTELLIGENT POWER DISTRIBUTION MODULE ENGINE ROOM)
Connector Color	WHITE

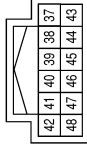

Terminal No.	Color of Wire	Signal Name
38	B	GND (SIG)
39	L	CAN-H
40	P	CAN-L

Terminal No.	Color of Wire	Signal Name
7G	L/W	-
10G	W/B	-
31G	L	-
37G	R/L	-
42G	P	-

Connector No.	E152
Connector Name	WIRE TO WIRE
Connector Color	WHITE

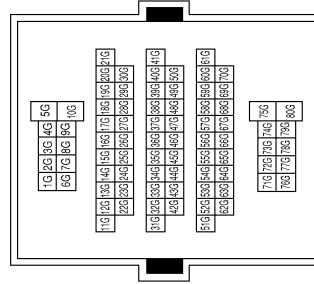

Connector No.	E139
Connector Name	WIRE TO WIRE
Connector Color	WHITE

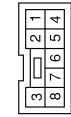

Terminal No.	Color of Wire	Signal Name
6	R/L	-

AWLIA0104GB



ILLUMINATION

< COMPONENT DIAGNOSIS >

Connector No.	B107
Connector Name	WIRE TO WIRE
Connector Color	WHITE

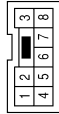

Terminal No.	Color of Wire	Signal Name
6	R/L	-

Connector No.	B146
Connector Name	WIRE TO WIRE
Connector Color	BROWN

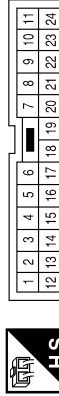

Terminal No.	Color of Wire	Signal Name
1	B	-
23	R/L	-

Connector No.	B149
Connector Name	WIRE TO WIRE
Connector Color	WHITE

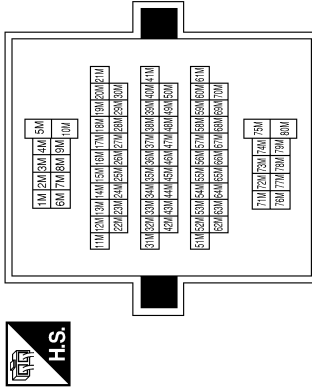

Terminal No.	Color of Wire	Signal Name
28M	R/L	-

Connector No.	B151
Connector Name	NAVI CONTROL UNIT
Connector Color	WHITE

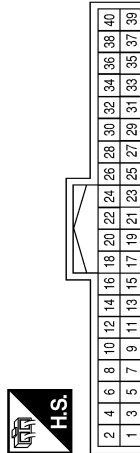

Terminal No.	Color of Wire	Signal Name
1	BR	GND

Connector No.	B152
Connector Name	NAVI CONTROL UNIT
Connector Color	WHITE

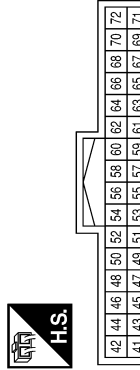

Terminal No.	Color of Wire	Signal Name
61	R/L	ILL

Connector No.	D1
Connector Name	WIRE TO WIRE
Connector Color	BROWN

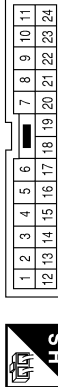

Terminal No.	Color of Wire	Signal Name
22	R/L	-

AWLIA0105GB

ILLUMINATION

< COMPONENT DIAGNOSIS >

Connector No.	D10
Connector Name	DOOR MIRROR REMOTE CONTROL SWITCH (WITHOUT AUTOMATIC DRIVE POSITIONER)
Connector Color	WHITE

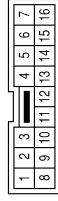

Terminal No.	Color of Wire	Signal Name
8	BR	-
9	R/L	-

Connector No.	D10
Connector Name	DOOR MIRROR REMOTE CONTROL SWITCH (WITH AUTOMATIC DRIVE POSITIONER)
Connector Color	BROWN

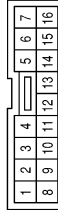

Terminal No.	Color of Wire	Signal Name
8	BR	-
9	R/L	-

Connector No.	D3
Connector Name	WIRE TO WIRE
Connector Color	WHITE

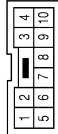

Terminal No.	Color of Wire	Signal Name
4	BR	-

Connector No.	R10
Connector Name	ROOM LAMP
Connector Color	WHITE



Terminal No.	Color of Wire	Signal Name
1	L	-
2	R/G	-

Connector No.	R6
Connector Name	WIRE TO WIRE
Connector Color	WHITE

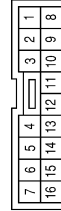

Terminal No.	Color of Wire	Signal Name
11	BR	-
13	R/L	-
15	BR	-
16	R/L	-

Connector No.	R1
Connector Name	WIRE TO WIRE
Connector Color	WHITE

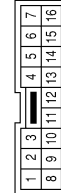

Terminal No.	Color of Wire	Signal Name
7	R/L	-
9	BR	-
11	R/L	-
16	BR	-

AWLIA0106GB

A
B
C
D
E
F
G
H
I
J
K
L
M
N
O
P

INL

ILLUMINATION

< COMPONENT DIAGNOSIS >

Connector No.	R103
Connector Name	REAR POWER DROP GLASS SWITCH
Connector Color	WHITE



Terminal No.	Color of Wire	Signal Name
2	BR	-
4	R/L	-

Connector No.	R102
Connector Name	FRONT ROOM/MAP LAMP ASSEMBLY
Connector Color	GRAY

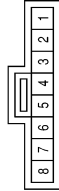

Terminal No.	Color of Wire	Signal Name
7	R/L	ILL+
8	BR	ILL-

Connector No.	R101
Connector Name	WIRE TO WIRE
Connector Color	WHITE

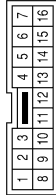

Terminal No.	Color of Wire	Signal Name
11	BR	-
13	R/L	-
15	BR	-
16	R/L	-

Connector No.	R204
Connector Name	REAR AUDIO REMOTE CONTROL UNIT
Connector Color	WHITE

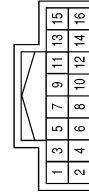

Terminal No.	Color of Wire	Signal Name
6	R/L	ILL+
15	B	GND

Connector No.	R201
Connector Name	WIRE TO WIRE
Connector Color	BROWN

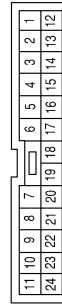

Terminal No.	Color of Wire	Signal Name
1	B	-
23	R/L	-

AWLIA0107GB

BCM (BODY CONTROL MODULE)

< ECU DIAGNOSIS >

ECU DIAGNOSIS

BCM (BODY CONTROL MODULE)

Description

INFOID:000000001621695

REFERENCE VALUES FOR BCM

For BCM reference values, refer to [BCS-35, "Reference Value"](#).

TERMINAL LAYOUT FOR BCM

For the terminal layout for the BCM, refer to [BCS-37, "Terminal Layout"](#).

PHYSICAL VALUES FOR BCM

For physical values for the BCM, refer to [BCS-37, "Physical Values"](#).

WIRING DIAGRAM - BCM

For the BCM wiring diagram, refer to [BCS-43, "Wiring Diagram"](#).

DTC INSPECTION PRIORITY CHART - BCM

For the BCM DTC inspection priority chart, refer to [BCS-46, "DTC Inspection Priority Chart"](#).

DTC INDEX - BCM

For the BCM DTC index, refer to [BCS-47, "DTC Index"](#).

A
B
C
D
E
F
G
H
I
J
K
INL
M
N
O
P

INTERIOR LIGHTING SYSTEM SYMPTOMS

< SYMPTOM DIAGNOSIS >

SYMPTOM DIAGNOSIS

INTERIOR LIGHTING SYSTEM SYMPTOMS

Symptom Table

INFOID:000000001621696

CAUTION:

Perform the self-diagnosis with CONSULT-III before the symptom diagnosis. Perform the trouble diagnosis if any DTC is detected.

Symptom	Possible cause	Inspection item
All of the following lamps do not turn ON <ul style="list-style-type: none"> • Room lamp (if equipped) • Front room/map lamp assembly (if equipped) • Personal lamp 2nd (if equipped) • Vanity lamps (if equipped) • Front step lamps • Rear step lamps (if equipped) • Puddle lamps (if equipped) • Foot lamps (if equipped) 	<ul style="list-style-type: none"> • Harness between BCM and each interior room lamp • BCM 	Battery saver output/power supply circuit. Refer to INL-16, "Description" .
Some or all of the following interior room lamps do not turn ON/OFF <ul style="list-style-type: none"> • Room lamp (if equipped) • Puddle lamps (if equipped) • Front room/map lamp assembly (if equipped) • Personal lamp 2nd row (if equipped) 	<ul style="list-style-type: none"> • Harness between BCM and each interior room lamp • BCM 	Interior room lamp control circuit. Refer to INL-18, "Description" .
Some or all of the following lamps do not turn ON/OFF <ul style="list-style-type: none"> • Front step lamps • Rear step lamps (if equipped) • Foot lamps (if equipped) 	<ul style="list-style-type: none"> • Harness between BCM and each step lamp • BCM 	Step lamp circuit. Refer to INL-21, "Description" .
Cargo lamps do not turn ON/OFF	<ul style="list-style-type: none"> • Harness between BCM and cargo lamp relay • BCM • Cargo lamp relay 	Cargo lamp relay. Refer to INL-23, "Description" .
Interior room lamp timer does not activate. (It turns ON/ OFF when the door opens/closes.)	—	Check the interior room lamp setting. Refer to INL-13, "BATTERY SAVER : CONSULT-III Function" .
Interior room lamp battery saver does not activate.	—	Check the interior room lamp battery saver setting. Refer to INL-13, "BATTERY SAVER : CONSULT-III Function" .

PRECAUTIONS

< PRECAUTION >

PRECAUTION

PRECAUTIONS

Supplemental Restraint System (SRS) "AIR BAG" and "SEAT BELT PRE-TENSIONER"

INFOID:000000001532100

The Supplemental Restraint System such as "AIR BAG" and "SEAT BELT PRE-TENSIONER", used along with a front seat belt, helps to reduce the risk or severity of injury to the driver and front passenger for certain types of collision. This system includes seat belt switch inputs and dual stage front air bag modules. The SRS system uses the seat belt switches to determine the front air bag deployment, and may only deploy one front air bag, depending on the severity of a collision and whether the front occupants are belted or unbelted. Information necessary to service the system safely is included in the SR and SB section of this Service Manual.

WARNING:

- To avoid rendering the SRS inoperative, which could increase the risk of personal injury or death in the event of a collision which would result in air bag inflation, all maintenance must be performed by an authorized NISSAN/INFINITI dealer.
- Improper maintenance, including incorrect removal and installation of the SRS, can lead to personal injury caused by unintentional activation of the system. For removal of Spiral Cable and Air Bag Module, see the SR section.
- Do not use electrical test equipment on any circuit related to the SRS unless instructed to in this Service Manual. SRS wiring harnesses can be identified by yellow and/or orange harnesses or harness connectors.

General precautions for service operations

INFOID:000000001532101

- When removing or disassembling any part, be careful not to damage or deform it. Protect parts which may get in the way with cloth.
- When removing parts with a screw driver or other tool, protect parts by wrapping them with vinyl or tape.
- Keep removed parts protected with cloth.
- If a non-reuseable part is removed, replace it with a new one.
- After re-assembly has been completed, make sure each part functions correctly.
- Never work with wet hands.
- Turn the lighting switch OFF before disconnecting and connecting the connector.
- Do not use organic solvent (paint thinner or gasoline) to clean lamps or remove sealant residue.

A
B
C
D
E
F
G
H
I
J
K
L
M
N
O
P

INL

INTERIOR ROOM LAMP

< ON-VEHICLE REPAIR >

ON-VEHICLE REPAIR

INTERIOR ROOM LAMP

Removal and Installation

INFOID:000000001532026

MAP LAMP

Removal

1. Disconnect the negative battery terminal.
2. Remove overhead console (3). Refer to [INT-21. "Removal and Installation"](#).
3. Disconnect connectors (4) and remove the map lamp screws (1), then remove map lamp (2) from overhead console.

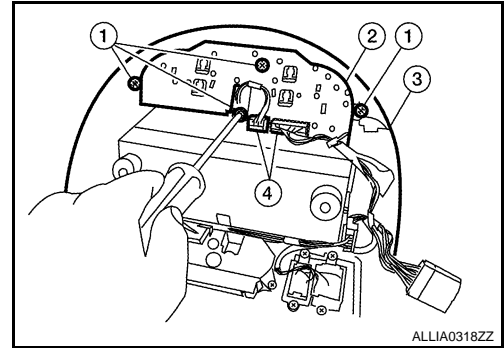

Installation

Installation is in the reverse order of removal.

Bulb Replacement

1. Disconnect the negative battery terminal.
2. Using a suitable tool (A), remove map lamp lens (1).
3. Release one side of the bulb (2) from the tab, then pull straight downward to remove.

Map lamp bulb : 12V - 8W

CAUTION:

Wrap a cloth around tool to protect the housing and lens.

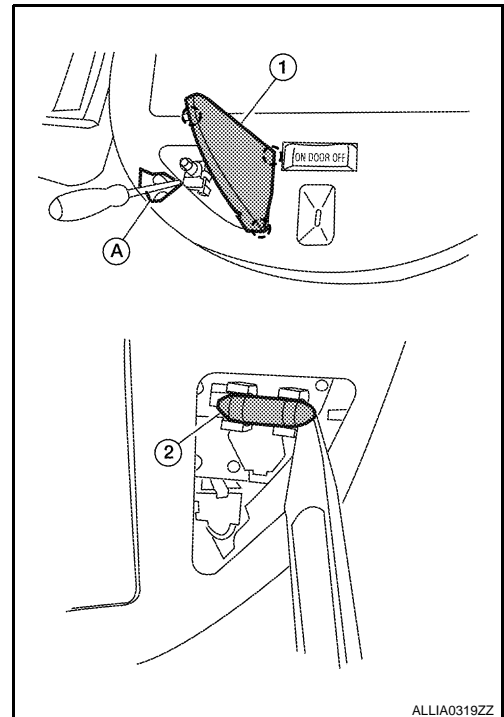

VANITY MIRROR LAMP

Removal

The vanity mirror lamp is replaced as part of the sunvisor assembly. Refer to [INT-21. "Removal and Installation"](#).

Installation

Installation is in the reverse order of removal.

Bulb Replacement

INTERIOR ROOM LAMP

< ON-VEHICLE REPAIR >

1. Disconnect the negative battery cable.
2. Using a suitable tool (A), release the tabs and remove the vanity mirror lamp lens (1).
3. Release one side of the bulb (2) from the tab, then pull straight out to remove.

Vanity mirror lamp bulb : 12V - 1.8W

CAUTION:

Wrap a cloth around tool to protect the housing and lens.

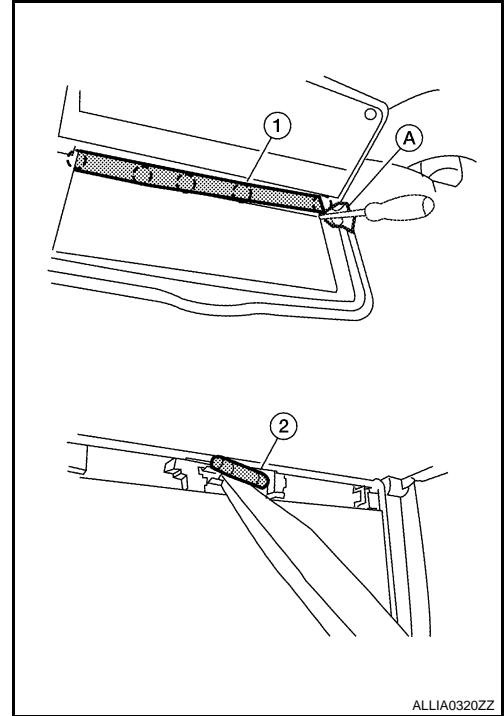

GLOVE BOX LAMP

Removal

1. Remove lower instrument panel RH and glove box. Refer to [IP-15, "Removal and Installation"](#).
2. Rotate glove box lamp socket and rotate counterclockwise to release from steering member.

Installation

Installation is in the reverse order of removal.

Bulb Replacement

1. Disconnect the negative battery terminal.
2. Remove lower instrument panel RH and glove box. Refer to [IP-15, "Removal and Installation"](#).
3. Pull bulb (2) straight out from glove box lamp socket (1) to remove.

Glove box lamp bulb : 12V - 3.4W

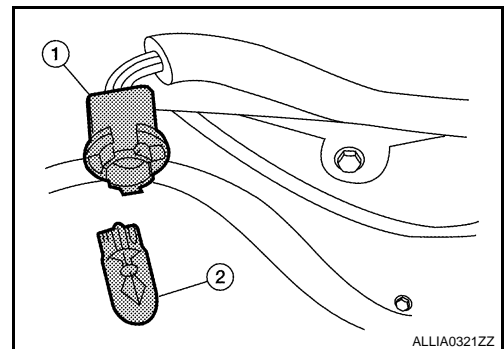

STEP LAMP

Removal

A
B
C
D
E
F
G
H
I
J
K
INL
M
N
O
P

INTERIOR ROOM LAMP

< ON-VEHICLE REPAIR >

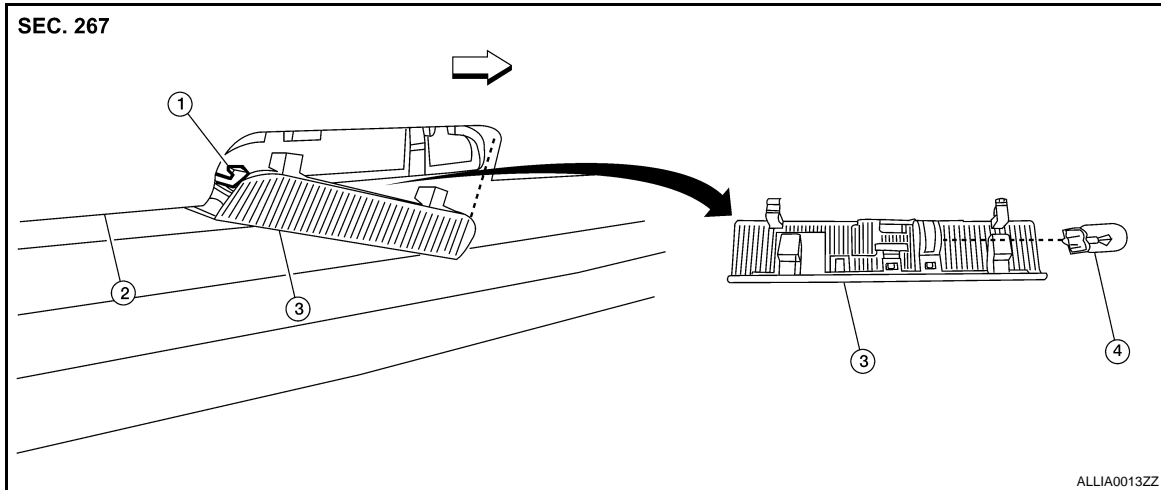

- | | | |
|------------------------|------------------|--------------------------|
| 1. Step lamp connector | 2. Door finisher | 3. Step lamp lens/socket |
| 4. Step lamp bulb | ← Vehicle front | |

1. Disconnect the negative battery terminal.
2. Insert a suitable tool between door finisher and step lamp lens/socket to release the pawls.
3. Disconnect the step lamp connector, then remove step lamp.

Installation

Installation is in the reverse order of removal.

Bulb Replacement

1. Disconnect the negative battery cable.
2. Remove the step lamp lens/socket.
3. Pull the bulb straight out to remove.

Step lamp bulb : 12V - 3.8W

PERSONAL LAMP (if equipped)

Removal

1. Disconnect the negative battery terminal.

INTERIOR ROOM LAMP

< ON-VEHICLE REPAIR >

2. Remove overhead console. Refer to [IINT-21, "Removal and Installation"](#).
3. Remove personal lamp (3) screws.
4. Disconnect personal lamp electrical connectors (1), then remove personal lamp (2) from overhead console.

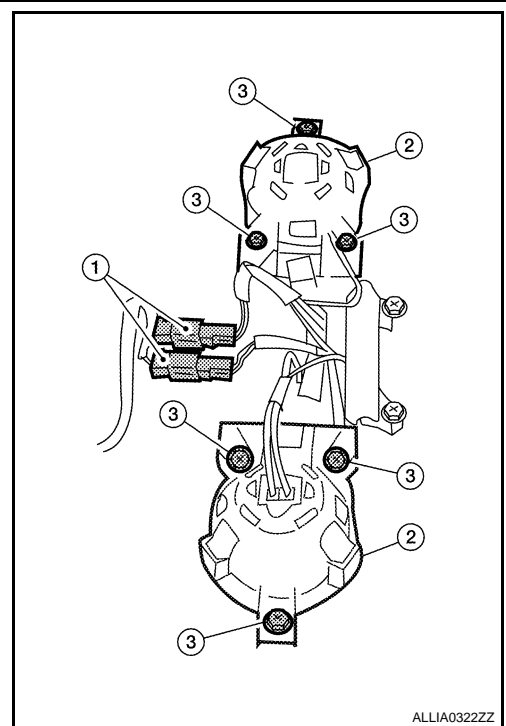

Installation

Installation is in the reverse order of removal.

Bulb Replacement

1. Disconnect the negative battery terminal.
2. Using a suitable tool (A), release the pawls and remove personal lamp lens (1).
3. Pull bulb (2) straight out to remove.

Personal lamp bulb : 12V - 6W

CAUTION:
Wrap a cloth around tool to protect the housing and lens.

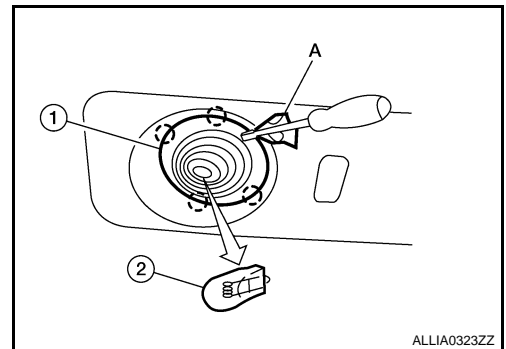

FOOTWELL LAMP

Removal

1. Disconnect the negative battery terminal.
2. Rotate footwell lamp socket (3) counterclockwise from bracket.

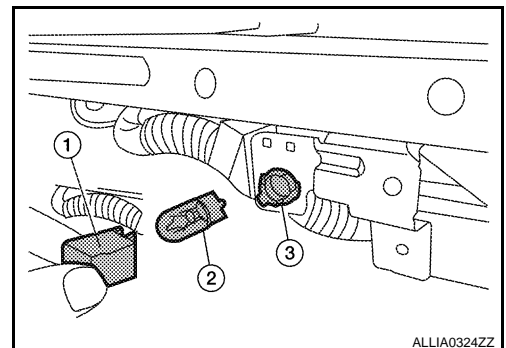

Installation

Installation is in the reverse order of removal.

Bulb Replacement

A
B
C
D
E
F
G
H
I
J
K
INL
M
N
O
P

INTERIOR ROOM LAMP

< ON-VEHICLE REPAIR >

1. Disconnect the negative battery terminal.
2. Release the pawls and remove bulb shield (1) from bracket.
3. Pull bulb (2) straight out from footwell lamp socket (3) to remove.

Footwell lamp bulb : 12V - 3.4W

ILLUMINATION

< ON-VEHICLE REPAIR >

ILLUMINATION

Removal and Installation

INFOID:000000001505548

ILLUMINATION CONTROL SWITCH

Removal

The illumination control switch (1) is replaced as a part of the combination meter assembly. Refer to [MWI-72, "Removal and Installation"](#).

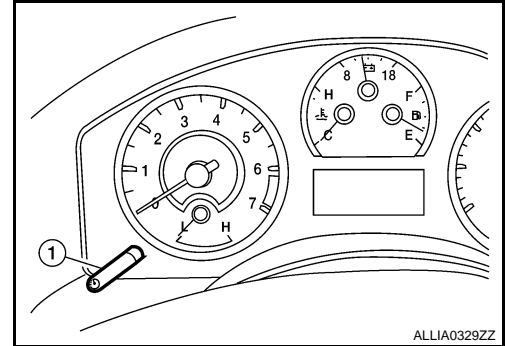

Installation

Installation is in the reverse order of removal.

CARGO LAMP (if equipped)

Removal

1. Disconnect the negative battery terminal.
2. Using a suitable tool (A), release the pawls and remove the cargo lamp lens (1).
3. Remove cargo lamp screws (2).
4. Disconnect the connector, then remove cargo lamp.

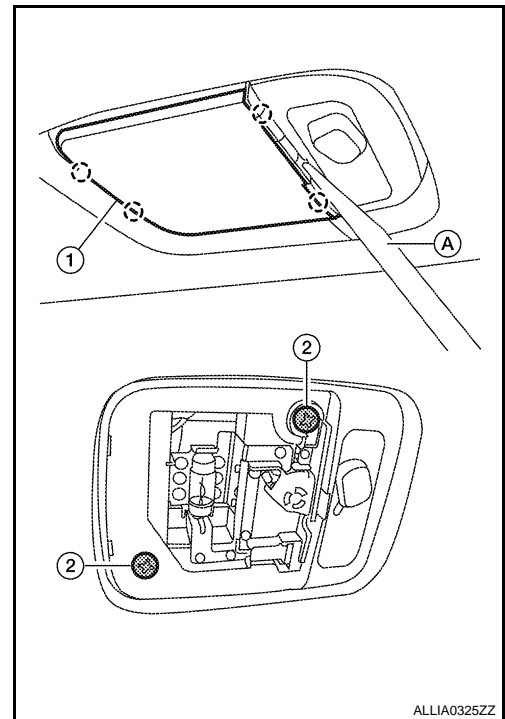

Installation

Installation is in the reverse order of removal.

Bulb Replacement

1. Disconnect the negative battery terminal.

A
B
C
D
E
F
G
H
I
J
K
INL
M
N
O
P

ILLUMINATION

< ON-VEHICLE REPAIR >

2. Using a suitable tool, release the pawls and remove the cargo lamp lens.
3. Release the cargo lamp bulb retainers (1), then pull bulb (2) straight out to remove.

Cargo lamp bulb

: 12V - 8W

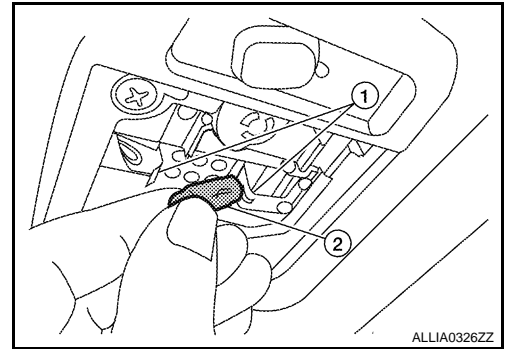

CONSOLE ILLUMINATION LAMP (if equipped)

Removal

The console illumination lamp (1) is replaced as part of the map lamp assembly (2). Refer to INTERIOR ROOM LAMP.

⇐: Vehicle front

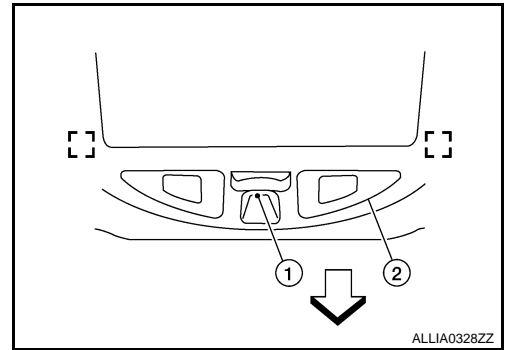

Installation

Installation is in the reverse order of removal.

Bulb Replacement

1. Disconnect the negative battery terminal.
2. Remove overhead console. Refer to INTERIOR - HEADLINER.
3. Rotate console illumination lamp bulb (1) counterclockwise, then pull straight out away from map lamp assembly (2) to remove.

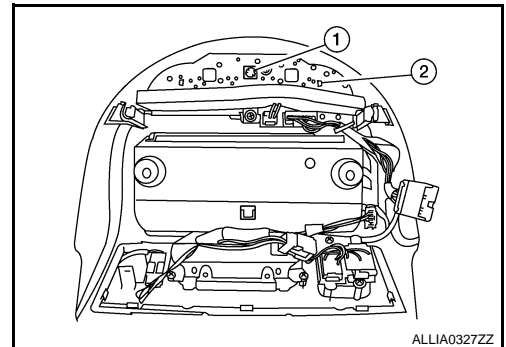

BULB SPECIFICATIONS

< SERVICE DATA AND SPECIFICATIONS (SDS)

SERVICE DATA AND SPECIFICATIONS (SDS)

BULB SPECIFICATIONS

Interior Lamp/Illumination

INFOID:000000001505547

Item	Wattage (W)*
Map Lamp	8
Vanity mirror lamp	1.8
Glove box lamp	3.4
Step lamp	3.8
Personal lamp	6
Footwell lamp	3.4
Cargo lamp	8
Console illumination lamp	-

*: Always check with the Parts Department for the latest parts information.

A
B
C
D
E
F
G
H
I
J
K
M
N
O
P

INL