

WT
SECTION
ROAD WHEELS & TIRES

A
B
C
D

WT

CONTENTS

BASIC INSPECTION	3	Special Repair Requirement	17	F
DIAGNOSIS AND REPAIR WORKFLOW	3	C1729 VEHICLE SPEED SIGNAL	18	
Repair Work Flow	3	Description	18	G
INSPECTION AND ADJUSTMENT	5	DTC Logic	18	
Preliminary Check	5	Vehicle Speed Signal	18	
Transmitter Wake Up Operation	5	ECU DIAGNOSIS	19	H
ID Registration Procedure	6	BCM (BODY CONTROL MODULE)	19	
FUNCTION DIAGNOSIS	8	Terminals and Reference Values (BCM)	19	I
TPMS	8	Wiring Diagram	19	
System Diagram	8	Self-Diagnosis	21	J
System Description	8	Flash Code Chart	22	
System Component	10	SYMPTOM DIAGNOSIS	24	K
DIAGNOSIS SYSTEM (BCM)	11	TPMS	24	
CONSULT-III Function (BCM)	11	Symptom Table	24	L
Self-Diagnosis	11	LOW TIRE PRESSURE WARNING LAMP		
COMPONENT DIAGNOSIS	13	DOES NOT TURN ON	25	M
C1708 - C1711 DATA FROM TRANSMITTER		Low Tire Pressure Warning Lamp Does Not Come		
NOT BEING RECEIVED	13	On When Ignition Switch Is Turned On	25	N
Description	13	LOW TIRE PRESSURE WARNING LAMP		
DTC Logic	13	STAYS ON	26	O
Data from Transmitter Not Being Received	13	Low Tire Pressure Warning Lamp Stays On When		
Special Repair Requirement	14	Ignition Switch Is Turned On	26	P
C1712 - C1715, C1720 - C1723, C1724 -		LOW TIRE PRESSURE WARNING LAMP		
C1727 TRANSMITTER MALFUNCTION	15	BLINKS	27	
Description	15	Low Tire Pressure Warning Lamp Flashes When		
DTC Logic	15	Ignition Switch Is Turned On	27	
Transmitter Malfunction	15	HAZARD WARNING LAMPS FLASH	28	
Special Repair Requirement	16	Hazard Warning Lamps Flash When Ignition		
C1716 - C1719 TRANSMITTER PRESSURE		Switch Is Turned On	28	
MALFUNCTION	17	"TIRE PRESSURE" INFORMATION IN DIS-		
Description	17	PLAY UNIT DOES NOT EXIST	29	
DTC Logic	17			
Transmitter Pressure Malfunction	17			

"TIRE PRESSURE" Information in Display Unit Does Not Exist	29	Commercial Service Tool	33
ID REGISTRATION CANNOT BE COMPLETED	30	ON-VEHICLE MAINTENANCE	34
ID Registration Cannot Be Completed	30	WHEEL	34
NOISE, VIBRATION, AND HARSHNESS (NVH) TROUBLESHOOTING	31	Inspection	34
NVH Troubleshooting Chart	31	WHEEL AND TIRE ASSEMBLY	35
PRECAUTION	32	Balancing Wheels	35
PRECAUTIONS	32	Rotation	36
Precaution for Supplemental Restraint System (SRS) "AIR BAG" and "SEAT BELT PRE-TENSIONER"	32	REMOVAL AND INSTALLATION	37
Precaution for work	32	REMOVAL AND INSTALLATION	37
PREPARATION	33	Transmitter (Pressure Sensor)	37
PREPARATION	33	SERVICE DATA AND SPECIFICATIONS (SDS)	39
Special Service Tool	33	SERVICE DATA AND SPECIFICATIONS (SDS)	39
		Road Wheel	39
		Tire	39

DIAGNOSIS AND REPAIR WORKFLOW

< BASIC INSPECTION >

BASIC INSPECTION

DIAGNOSIS AND REPAIR WORKFLOW

Repair Work Flow

INFOID:000000001663779

WORK FLOW

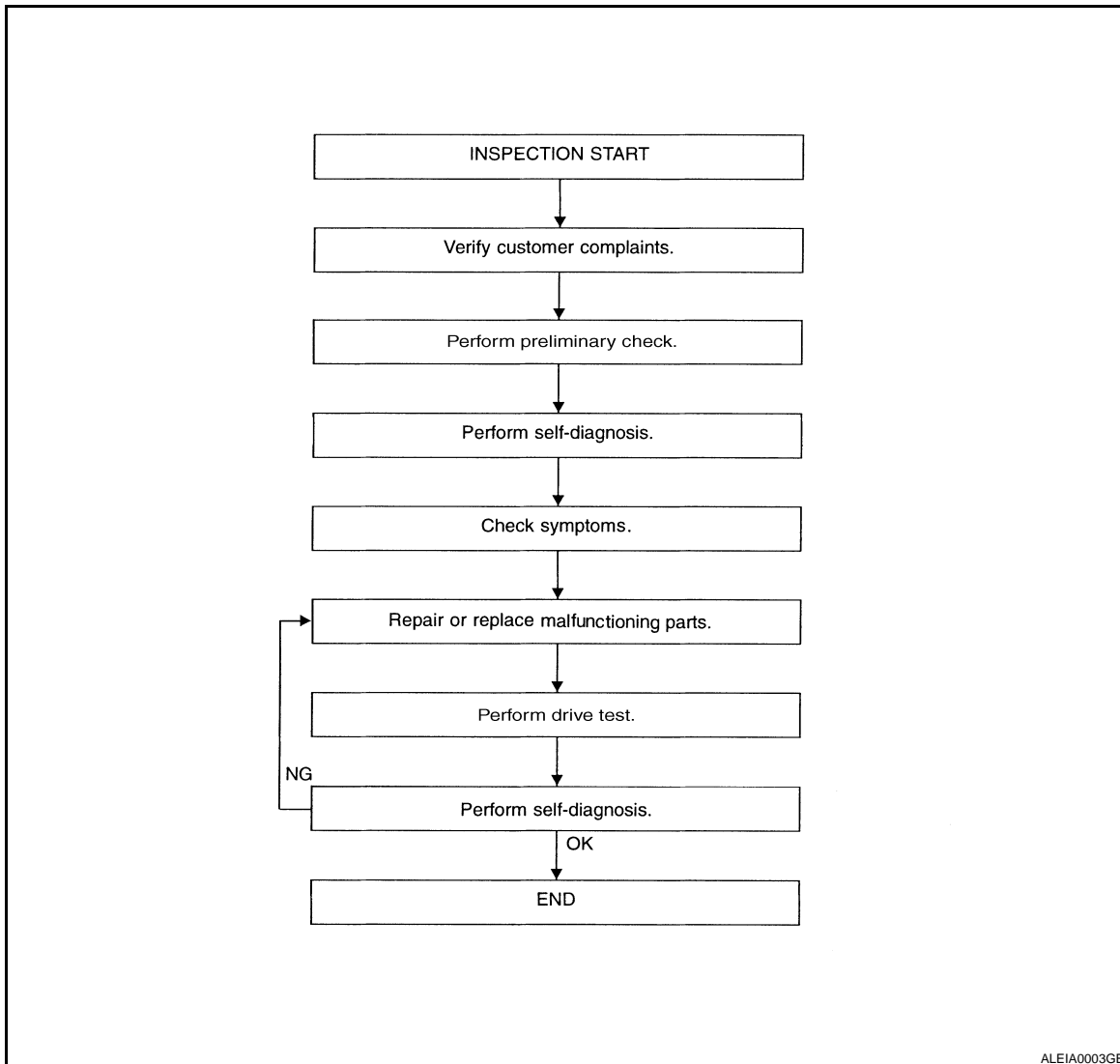

[WT-5. "Preliminary Check"](#)

[WT-21. "Self-Diagnosis"](#)

[WT-24. "Symptom Table"](#)

DETAILED FLOW

1. CUSTOMER INFORMATION

Interview the customer to obtain detailed information about the symptom.

>> GO TO 2

2. PRELIMINARY CHECK

Perform preliminary check. Refer to [WT-5. "Preliminary Check"](#)

>> GO TO 3

A
B
C
D
WT
F
G
H
I
J
K
L
M
N
O
P

DIAGNOSIS AND REPAIR WORKFLOW

< BASIC INSPECTION >

3.SELF-DIAGNOSIS

Perform SELF-DIAGNOSIS. Refer to [WT-21. "Self-Diagnosis"](#) (with CONSULT-III) or [WT-22. "Flash Code Chart"](#) (without CONSULT-III).

>> GO TO 4

4.SYMPTOM

Check for symptoms. Refer to [WT-24. "Symptom Table"](#).

>> GO TO 5

5.MALFUNCTIONING PARTS

Repair or replace the applicable parts.

>> GO TO 6

6.DRIVE TEST

1. Perform a drive test.
2. Check the low tire pressure warning lamp.

>> GO TO 7

7.SELF-DIAGNOSIS

Perform SELF-DIAGNOSIS. Refer to [WT-21. "Self-Diagnosis"](#) (with CONSULT-III) or [WT-22. "Flash Code Chart"](#) (without CONSULT-III).

Are any DTC's displayed?

- YES >> GO TO 5
NO >> Inspection End.

INSPECTION AND ADJUSTMENT

< BASIC INSPECTION >

INSPECTION AND ADJUSTMENT

Preliminary Check

INFOID:000000001663780

1. TIRE PRESSURE

Check all tire pressures. Refer to [WT-39, "Tire"](#).

Do tire pressures match specification?

YES >> GO TO 2.

NO >> Adjust tire pressures to specified value.

2. LOW TIRE PRESSURE WARNING LAMP

Check low tire pressure warning lamp activation.

Does the low tire pressure warning lamp activate for one second when ignition switch is turned ON?

YES >> GO TO 3.

NO >> GO TO [WT-25, "Low Tire Pressure Warning Lamp Does Not Come On When Ignition Switch Is Turned On"](#).

3. BCM CONNECTOR

1. Disconnect BCM harness connectors.
2. Check terminals for damage or loose connections.
3. Reconnect harness connectors.

Are BCM connectors damaged or loose?

YES >> Repair or replace damaged parts.

NO >> GO TO 4.

4. TRANSMITTER ACTIVATION TOOL

Check battery in transmitter activation tool.

Is transmitter activation tool battery fully charged?

YES >> Perform self-diagnosis. Refer to [WT-11, "Self-Diagnosis"](#).

NO >> Replace battery in transmitter activation tool.

Transmitter Wake Up Operation

INFOID:000000001663781

NOTE:

This procedure must be done after replacement of a low tire pressure warning transmitter or BCM. New replacement transmitters are provided "asleep" and must first be "woken up" using Transmitter Activation Tool J-45295 before ID registration can be performed.

1. Turn ignition switch ON. Push the transmitter activation tool against the tire near the front left transmitter. Press the button for 5 seconds. The hazard warning lamps flash per the following diagram.

Tool number : (J-45295)

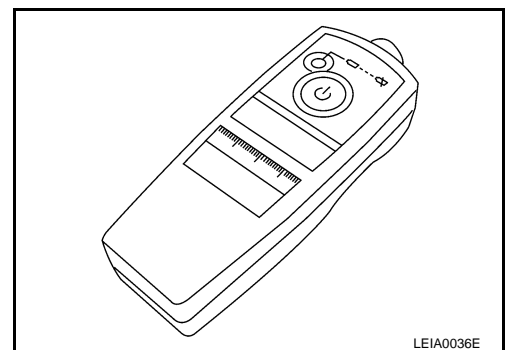

2. Repeat this procedure for each tire in the following order: FL, FR, RR, RL.

INSPECTION AND ADJUSTMENT

< BASIC INSPECTION >

- When the BCM finishes assigning each tire ID, the BCM flashes the hazard warning lamps and sends flashing indicator status by CAN according to the following time chart.

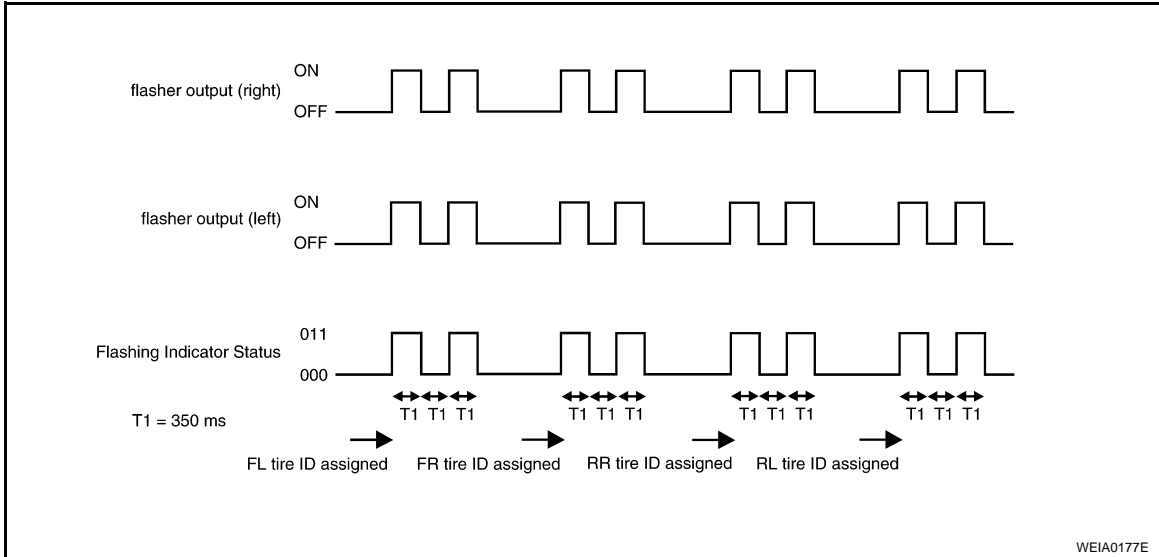

- After completing wake up of all transmitters, make sure low tire pressure warning lamp goes out.

ID Registration Procedure

INFOID:000000001663782

ID REGISTRATION WITH TRANSMITTER ACTIVATION TOOL

NOTE:

This procedure must be done after replacement of a low tire pressure warning transmitter or BCM. New replacement transmitters are provided "asleep" and must first be "woken up" using Transmitter Activation Tool J-45295 before ID registration can be performed.

- Connect CONSULT-III.
- Select "ID REGIST" under BCM.
- Push the transmitter activation tool against the tire near the front left transmitter. Press the button for 5 seconds.

Tool number : (J-45295)

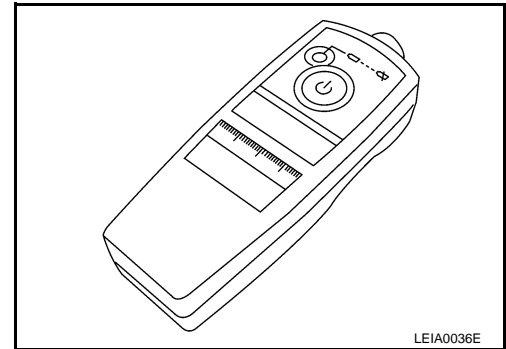

- Register the IDs in order from FR LH, FR RH, RR RH and RR LH. When ID registration of each wheel has been completed, the hazard warning lamps flash.

Step	Activation tire position	Hazard warning lamp	CONSULT-III
1	Front LH	2 times flashing	"YET" ↓ "DONE"
2	Front RH		
3	Rear RH		
4	Rear LH		

- After completing all ID registrations, press "END" to complete the procedure.

NOTE:

Be sure to register all of the IDs in order from FR LH, FR RH, RR RH, to RR LH, or the self-diagnostic results display will not function properly.

ID REGISTRATION WITHOUT TRANSMITTER ACTIVATION TOOL

NOTE:

INSPECTION AND ADJUSTMENT

< BASIC INSPECTION >

This procedure must be done after replacement of a low tire pressure warning transmitter or BCM. New replacement transmitters are provided "asleep" and must first be "woken up" using Transmitter Activation Tool J-45295 before ID registration can be performed.

1. Connect CONSULT-III.
2. Select "ID REGIST" under BCM.
3. Adjust the tire pressures to the values shown in the table and drive the vehicle at 40 km/h (25 MPH) or more for a few minutes.

Tire position	Tire pressure kPa (kg/cm ² , psi)
Front LH	250 (2.5, 36)
Front RH	230 (2.3, 33)
Rear RH	210 (2.1, 30)
Rear LH	190 (1.9, 27)

4. After completing all ID registrations, press "END" to complete the procedure.

Activation tire position	CONSULT-III
Front LH	"YET" ↓ "DONE"
Front RH	
Rear RH	
Rear LH	

5. Inflate all tires to proper pressure. Refer to [WT-39, "Tire"](#).

TPMS

< FUNCTION DIAGNOSIS >

FUNCTION DIAGNOSIS

TPMS

System Diagram

INFOID:000000001663783

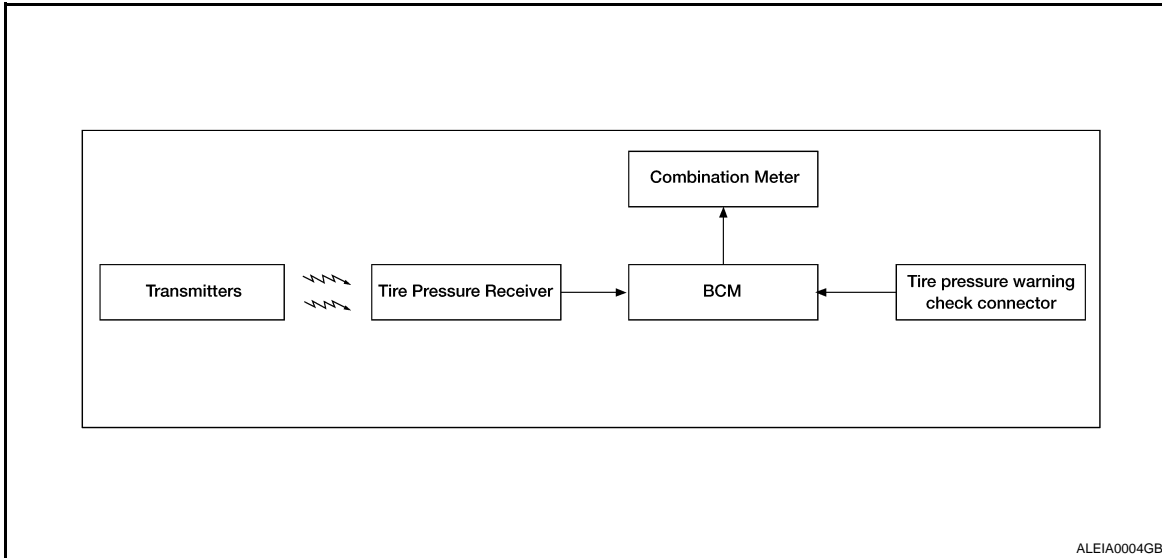

System Description

INFOID:000000001663784

BODY CONTROL MODULE (BCM)

The BCM is shown with the lower instrument panel LH removed. The BCM reads the air pressure signal received by the remote keyless entry receiver, and controls the low tire pressure warning lamp as shown below. It also has a self-diagnosis function to detect a system malfunction.

Condition	Low tire pressure warning lamp
System normal	On for 1 second after ignition ON
Tire less than 193 kPa (2.0 kg/cm ² , 28 psi) [Flat tire]	ON
TPMS malfunction	After key ON, flashes once per second for 1 minute, then stays ON

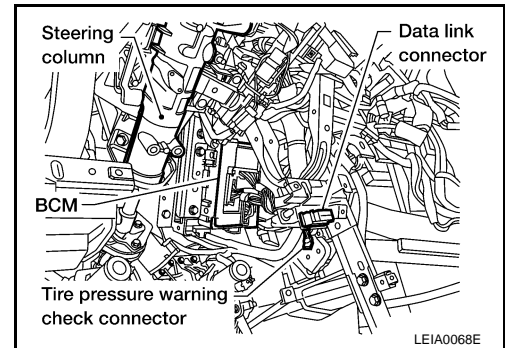

TRANSMITTER

A sensor-transmitter integrated with a valve is installed in each wheel, and transmits a detected air pressure signal in the form of a radio wave. The radio signal is received by the remote keyless entry receiver.

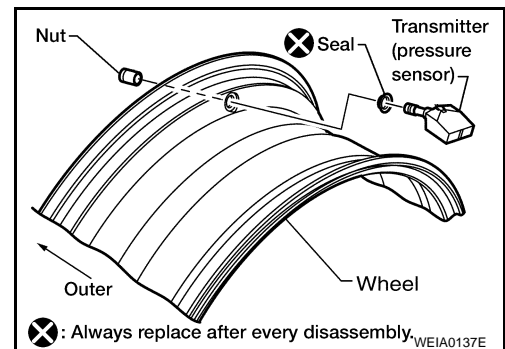

REMOTE KEYLESS ENTRY RECEIVER

TPMS

< FUNCTION DIAGNOSIS >

The remote keyless entry receiver is shown with the instrument panel RH removed. The remote keyless entry receiver receives the air pressure signal transmitted by the transmitter in each wheel.

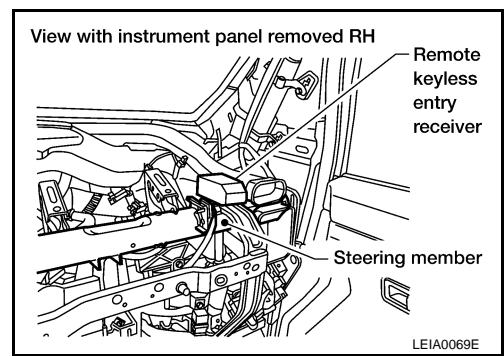

COMBINATION METER

The combination meter receives tire pressure status from the BCM using CAN communication. When a low tire pressure condition is sensed by the BCM, the combination meter low tire pressure warning lamp is activated.

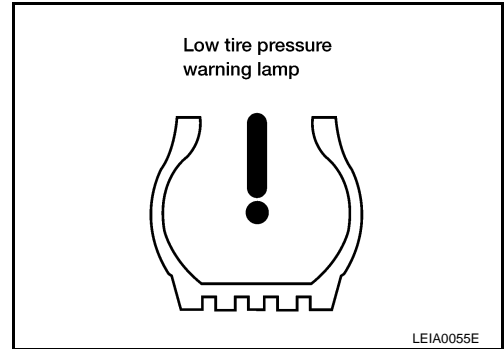

TIRE PRESSURE WARNING CHECK CONNECTOR

The tire pressure warning check connector can be grounded in order to initiate self-diagnosis without CONSULT-III. The tire pressure warning check connector is located behind the lower portion of the instrument panel LH.

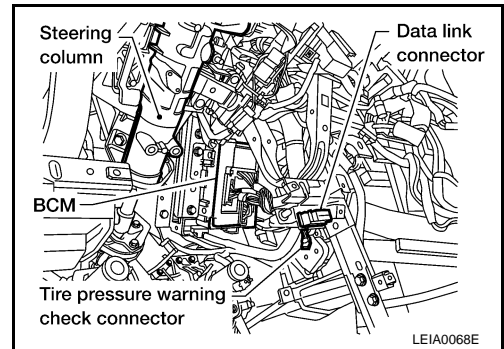

DISPLAY UNIT (with NAVI)

Displays the air pressure of each tire.

NOTE:

After the ignition switch is turned on, the pressure values will not be displayed until the data of each wheel is received.

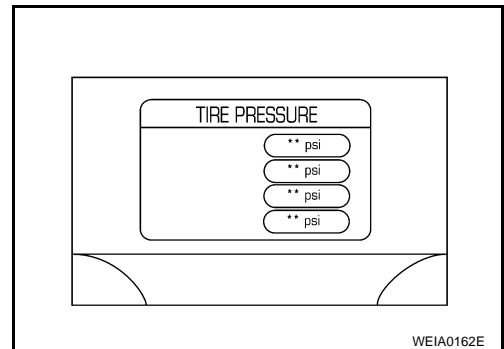

TPMS

< FUNCTION DIAGNOSIS >

System Component

INFOID:000000001663785

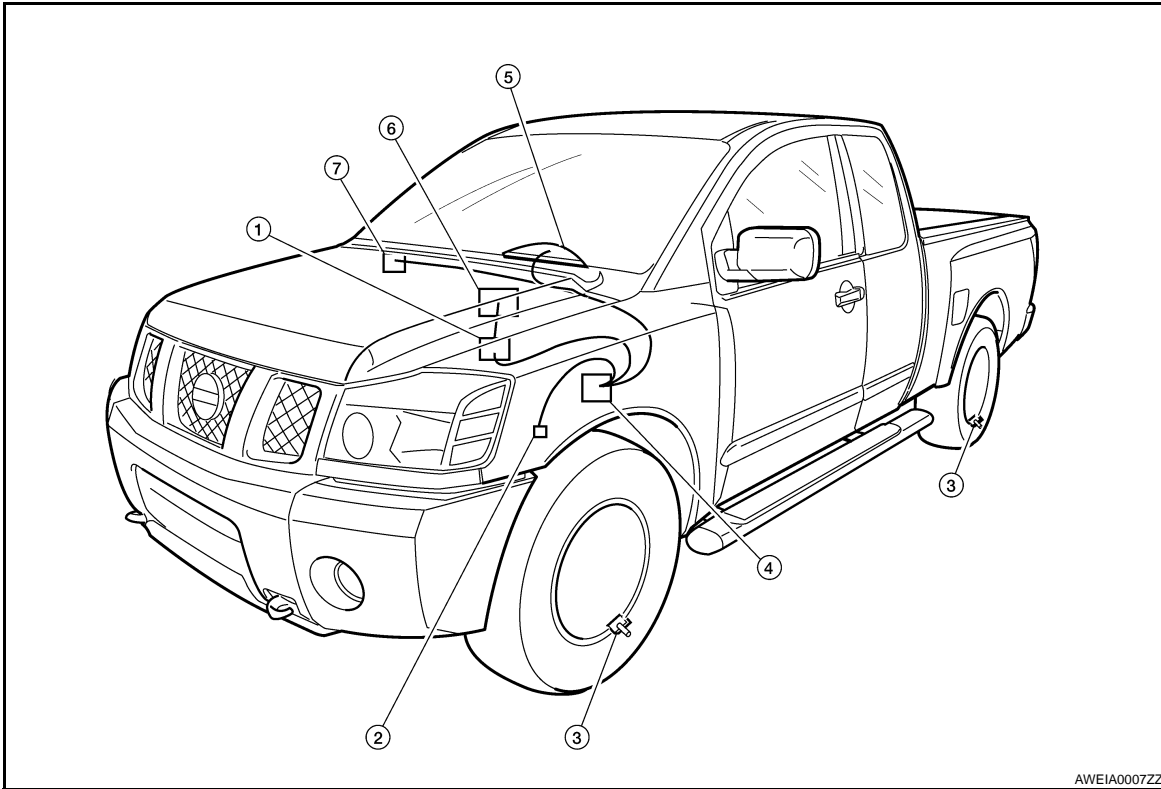

AWEIA0007ZZ

- | | | |
|--|--|--------------------------------|
| 1. Display control unit
(With NAVI) | 2. Tire pressure warning check connector
M123 | 3. Transmitter |
| 4. BCM
M18, M20 | 5. Combination meter
M24 | 6. Display unit
(With NAVI) |
| 7. Remote keyless entry receiver
M120 | | |

DIAGNOSIS SYSTEM (BCM)

< FUNCTION DIAGNOSIS >

DIAGNOSIS SYSTEM (BCM)

CONSULT-III Function (BCM)

INFOID:000000001663786

CONSULT-III can display each diagnostic item using the diagnostic test modes shown following.

BCM diagnostic test item	Diagnostic mode	Description
Inspection by part	WORK SUPPORT	Supports inspections and adjustments. Commands are transmitted to the BCM for setting the status suitable for required operation, input/output signals are received from the BCM and received data is displayed.
	DATA MONITOR	Displays BCM input/output data in real time.
	ACTIVE TEST	Operation of electrical loads can be checked by sending drive signal to them.
	SELF-DIAG RESULTS	Displays BCM self-diagnosis results.
	CAN DIAG SUPPORT MNTR	The result of transmit/receive diagnosis of CAN communication can be read.
	ECU PART NUMBER	BCM part number can be read.
	CONFIGURATION	Performs BCM configuration read/write functions.

Self-Diagnosis

INFOID:000000001663787

DESCRIPTION

During driving, the tire pressure monitoring system receives the signal transmitted from the transmitter installed in each wheel, and turns on the low tire pressure warning lamp when the tire pressure becomes low. The control unit (BCM) for this system has pressure judgement and self-diagnosis functions.

FUNCTION

When the tire pressure monitoring system detects low inflation pressure or an internal malfunction, the low tire pressure warning lamp in the combination meter comes on. The malfunction is indicated by the low tire pressure warning lamp flashing.

CONSULT-III Application to Tire Pressure Monitoring System

ITEM	SELF-DIAGNOSTIC RESULTS	DATA MONITOR
Front - Left transmitter	×	×
Front - Right transmitter	×	×
Rear - Left transmitter	×	×
Rear - Right transmitter	×	×
Warning lamp	—	×
Vehicle speed	×	×
CAN Communication	×	×

× : Applicable

— : Not applicable

Data Monitor Mode

MONITOR	CONDITION	SPECIFICATION
VHCL SPEED	Drive vehicle.	Vehicle speed (km/h or MPH)
AIR PRESS FL AIR PRESS FR AIR PRESS RR AIR PRESS RL	<ul style="list-style-type: none"> Drive vehicle for a few minutes. or <ul style="list-style-type: none"> Ignition switch ON and activation tool is transmitting activation signals. 	Tire pressure (kPa or psi)

DIAGNOSIS SYSTEM (BCM)

< FUNCTION DIAGNOSIS >

MONITOR	CONDITION	SPECIFICATION
ID REGST FL1 ID REGST FR1 ID REGST RR1 ID REGST RL1	Ignition switch ON	ID not registered: YET ID registered: DONE
WARNING LAMP		Low tire pressure warning lamp on: ON Low tire pressure warning lamp off: OFF

NOTE:

Before performing the self-diagnosis, be sure to register the ID, or the actual malfunction location may be different from that displayed on CONSULT-III.

C1708 - C1711 DATA FROM TRANSMITTER NOT BEING RECEIVED

< COMPONENT DIAGNOSIS >

COMPONENT DIAGNOSIS

C1708 - C1711 DATA FROM TRANSMITTER NOT BEING RECEIVED

Description

INFOID:000000001663788

Tire pressure data for one or more transmitters is not being received by the BCM.

DTC Logic

INFOID:000000001663789

DTC DETECTION LOGIC

DTC	CONSULT-III	DTC detecting condition
C1708	[NO - DATA] - FL	Data from FL transmitter cannot be received.
C1709	[NO - DATA] - FR	Data from FR transmitter cannot be received.
C1710	[NO - DATA] - RR	Data from RR transmitter cannot be received.
C1711	[NO - DATA] - RL	Data from RL transmitter cannot be received.

DTC CONFIRMATION PROCEDURE

1.ID REGISTRATION AND VEHICLE DRIVING

1. Carry out ID registration of all transmitters.
2. Drive at a speed of 40 km/h (25 MPH) or more for 3 minutes, and then drive the vehicle at any speed for 10 minutes.
3. Check all tire pressures with CONSULT-III within 5 minutes.

Does "DATA MONITOR ITEM" display tire pressure as normal without any warning lamp?

- YES >> Inspection End.
NO >> Refer to [WT-13, "Data from Transmitter Not Being Received"](#).

Data from Transmitter Not Being Received

INFOID:000000001663790

FLASH CODE NO. 21, 22, 23 or 24

1.CHECK BCM

Drive for several minutes. Check all tire pressures with CONSULT-III.

Are all tire pressures displayed as 0 kPa?

- YES >> GO TO 2
NO >> GO TO 3

2.CHECK TIRE PRESSURE RECEIVER CONNECTOR

Check tire pressure receiver connector for damage or loose connection.

Is tire pressure receiver connector damaged or loose?

- YES >> Repair or replace tire pressure receiver connector.
NO >> Replace BCM, then GO TO 3. Refer to [BCS-50, "Removal and Installation"](#).

3.PERFORM ID REGISTRATION

Carry out ID registration of all transmitters. Refer to [WT-6, "ID Registration Procedure"](#).

Is there a tire that cannot register ID?

- YES >> Replace malfunctioning transmitter, then GO TO 5. Refer to [WT-37, "Transmitter \(Pressure Sensor\)"](#).
NO >> GO TO 4

4.DRIVE VEHICLE

1. Drive at a speed of 40 km/h (25 MPH) or more for several minutes without stopping.
2. Check all tire pressures with CONSULT-III within 15 minutes after vehicle speed becomes 17 km/h (11 MPH).

Does "DATA MONITOR ITEM" display tire pressure as normal without any warning lamp?

C1708 - C1711 DATA FROM TRANSMITTER NOT BEING RECEIVED

< COMPONENT DIAGNOSIS >

- YES >> Inspection End.
- NO >> GO TO 5

5.ID REGISTRATION AND VEHICLE DRIVING

1. Carry out ID registration of all transmitters.
2. Drive at a speed of 40 km/h (25 MPH) or more for 3 minutes, and then drive the vehicle at any speed for 10 minutes.
3. Check all tire pressures with CONSULT-III within 5 minutes.

Does "DATA MONITOR ITEM" display tire pressure as normal without any warning lamp?

- YES >> Inspection End.
- NO >> Proceed to the inspection applicable to DTC.

Special Repair Requirement

INFOID:000000001663791

Perform preliminary check. Refer to [WT-5. "Preliminary Check"](#).

C1712 - C1715, C1720 - C1723, C1724 - C1727 TRANSMITTER MALFUNCTION

< COMPONENT DIAGNOSIS >

C1712 - C1715, C1720 - C1723, C1724 - C1727 TRANSMITTER MALFUNCTION

Description

INFOID:000000001663792

One or more transmitters are malfunctioning internally.

DTC Logic

INFOID:000000001663793

DTC DETECTION LOGIC

DTC	CONSULT-III	DTC detecting condition
C1712	[CHECKSUM - ERR] - FL	Checksum data from FL transmitter is malfunctioning.
C1713	[CHECKSUM - ERR] - FR	Checksum data from FR transmitter is malfunctioning.
C1714	[CHECKSUM - ERR] - RR	Checksum data from RR transmitter is malfunctioning.
C1715	[CHECKSUM - ERR] - RL	Checksum data from RL transmitter is malfunctioning.
C1720	[CODE - ERR] - FL	Function code data from FL transmitter is malfunctioning.
C1721	[CODE - ERR] - FR	Function code data from FR transmitter is malfunctioning.
C1722	[CODE - ERR] - RR	Function code data from RR transmitter is malfunctioning.
C1723	[CODE - ERR] - RL	Function code data from RL transmitter is malfunctioning.
C1724	[BATT - VOLT - LOW] - FL	Battery voltage of FL transmitter drops.
C1725	[BATT - VOLT - LOW] - FR	Battery voltage of FR transmitter drops.
C1726	[BATT - VOLT - LOW] - RR	Battery voltage of RR transmitter drops.
C1727	[BATT - VOLT - LOW] - RL	Battery voltage of RL transmitter drops.

DTC CONFIRMATION PROCEDURE

1. DRIVE VEHICLE

1. Drive at a speed of 40 km/h (25 MPH) or more for 3 minutes, and then drive the vehicle at any speed for 10 minutes.
2. Check all tire pressures with CONSULT-III within 5 minutes.

Does "DATA MONITOR ITEM" display tire pressure as normal without any warning lamp?

- YES >> Inspection End.
NO >> Refer to [WT-15. "Transmitter Malfunction"](#).

Transmitter Malfunction

INFOID:000000001663794

FLASH CODE NO. 31 - 34, 41 - 44, 45 - 48

1. PERFORM ID REGISTRATION

1. Carry out ID registration of all transmitters. Refer to [WT-6. "ID Registration Procedure"](#).
2. Drive at a speed of 40 km/h (25 MPH) or more for 3 minutes, and then drive the vehicle at any speed for 10 minutes.

>> GO TO 2

2. REPLACE TRANSMITTER

1. Check low tire pressure warning lamp again for flashing, replace malfunctioning transmitter. Refer to [WT-37. "Transmitter \(Pressure Sensor\)"](#).
2. Carry out ID registration of all transmitters.

Can ID registration of all transmitters be completed?

- YES >> GO TO 3
NO >> GO TO [WT-13. "Data from Transmitter Not Being Received"](#).

3. DRIVE VEHICLE

C1712 - C1715, C1720 - C1723, C1724 - C1727 TRANSMITTER MALFUNCTION

< COMPONENT DIAGNOSIS >

1. Drive at a speed of 40 km/h (25 MPH) or more for 3 minutes, and then drive the vehicle at any speed for 10 minutes.
2. Check all tire pressures with CONSULT-III within 5 minutes.

Does "DATA MONITOR ITEM" display tire pressure as normal without any warning lamp?

YES >> Inspection End.

NO >> Replace malfunctioning transmitter, and perform Step 3 again.

Special Repair Requirement

INFOID:000000001663795

Perform preliminary check. Refer to [WT-5, "Preliminary Check"](#).

C1716 - C1719 TRANSMITTER PRESSURE MALFUNCTION

< COMPONENT DIAGNOSIS >

C1716 - C1719 TRANSMITTER PRESSURE MALFUNCTION

Description

INFOID:000000001663796

Air pressure data from one or more transmitters is out of range.

DTC Logic

INFOID:000000001663797

DTC DETECTION LOGIC

DTC	CONSULT - III	DTC detecting condition
C1716	[PRESSDATA - ERR] FL	Air pressure data from FL transmitter is malfunctioning.
C1717	[PRESSDATA - ERR] FR	Air pressure data from FR transmitter is malfunctioning.
C1718	[PRESSDATA - ERR] RR	Air pressure data from RR transmitter is malfunctioning.
C1719	[PRESSDATA - ERR] RL	Air pressure data from RL transmitter is malfunctioning.

DTC CONFIRMATION PROCEDURE

1.ID REGISTRATION AND VEHICLE DRIVING

1. Carry out ID registration of all transmitters.
2. Drive at a speed of 40 km/h (25 MPH) or more for 3 minutes, and then drive the vehicle at any speed for 10 minutes.
3. Check all tire pressures with CONSULT-III within 5 minutes.

Does "DATA MONITOR ITEM" display tire pressure as normal without any warning lamp?

- YES >> Inspection End.
NO >> Refer to [WT-17. "Transmitter Pressure Malfunction"](#).

Transmitter Pressure Malfunction

INFOID:000000001663798

FLASH CODE NO. 35 - 38

1.CHECK ALL TIRE PRESSURES

Check all tire pressures. Refer to [WT-39. "Tire"](#).

Are there any tires with pressure of 64 psi or more?

- YES >> Adjust tire pressure to specified value.
NO >> GO TO 2

2.ID REGISTRATION AND VEHICLE DRIVING

1. Carry out ID registration of all transmitters. Refer to [WT-6. "ID Registration Procedure"](#).
2. Drive at a speed of 40 km/h (25 MPH) or more for several minutes without stopping.
3. Check all tire pressures with CONSULT-III within 15 minutes after vehicle speed becomes 17 km/h (11 MPH).

Does "DATA MONITOR ITEM" display 64 psi or more?

- YES >> Replace transmitter. Refer to [WT-37. "Transmitter \(Pressure Sensor\)"](#). GO TO 3.
NO >> GO TO 3

3.ID REGISTRATION AND VEHICLE DRIVING

1. Carry out ID registration of all transmitters.
2. Drive at a speed of 40 km/h (25 MPH) or more for 3 minutes, and then drive the vehicle at any speed for 10 minutes.
3. Check all tire pressures with CONSULT-III within 5 minutes.

Does "DATA MONITOR ITEM" display tire pressure as normal without any warning lamp?

- YES >> Inspection End.
NO >> Proceed to the inspection applicable to DTC.

Special Repair Requirement

INFOID:000000001663799

Perform preliminary check. Refer to [WT-5. "Preliminary Check"](#).

C1729 VEHICLE SPEED SIGNAL

< COMPONENT DIAGNOSIS >

C1729 VEHICLE SPEED SIGNAL

Description

INFOID:000000001663800

The vehicle speed signal is not being detected by the BCM.

DTC Logic

INFOID:000000001663801

DTC DETECTION LOGIC

DTC	CONSULT - III	DTC detecting condition
C1729	VHCL SPEED SIG ERR	Vehicle speed signal is in error.

DTC CONFIRMATION PROCEDURE

1. CHECK SELF-DIAGNOSTIC RESULTS

1. On "SELECT DIAG MODE", select the "SELF-DIAG RESULT" screen.
2. Check display contents on "SELF DIAG RESULT" screen.

Is the "CAN COMM CIRCUIT" displayed in the self-diagnosis display?

YES >> Refer to [WT-18, "Vehicle Speed Signal"](#).

NO >> Inspection end.

Vehicle Speed Signal

INFOID:000000001663802

FLASH CODE NO. 52

1. CHECK SELF-DIAGNOSTIC RESULTS

1. On "SELECT DIAG MODE", select the "SELF-DIAG RESULT" screen.
2. Check display contents on "SELF DIAG RESULT" screen.

Is the "CAN COMM CIRCUIT" displayed in the self-diagnosis display?

YES >> Perform trouble diagnosis for CAN communication system.

NO >> Check combination meter. [MWI-27, "CONSULT-III Function \(METER/M&A\)"](#)

BCM (BODY CONTROL MODULE)

< ECU DIAGNOSIS >

ECU DIAGNOSIS

BCM (BODY CONTROL MODULE)

Terminals and Reference Values (BCM)

Refer to [BCS-37, "Physical Values"](#).

Wiring Diagram

INFOID:000000001663803

INFOID:000000001663804

◀ NV : WITH NAVI
 ▬ : DATA LINE

TIRE PRESSURE MONITORING SYSTEM

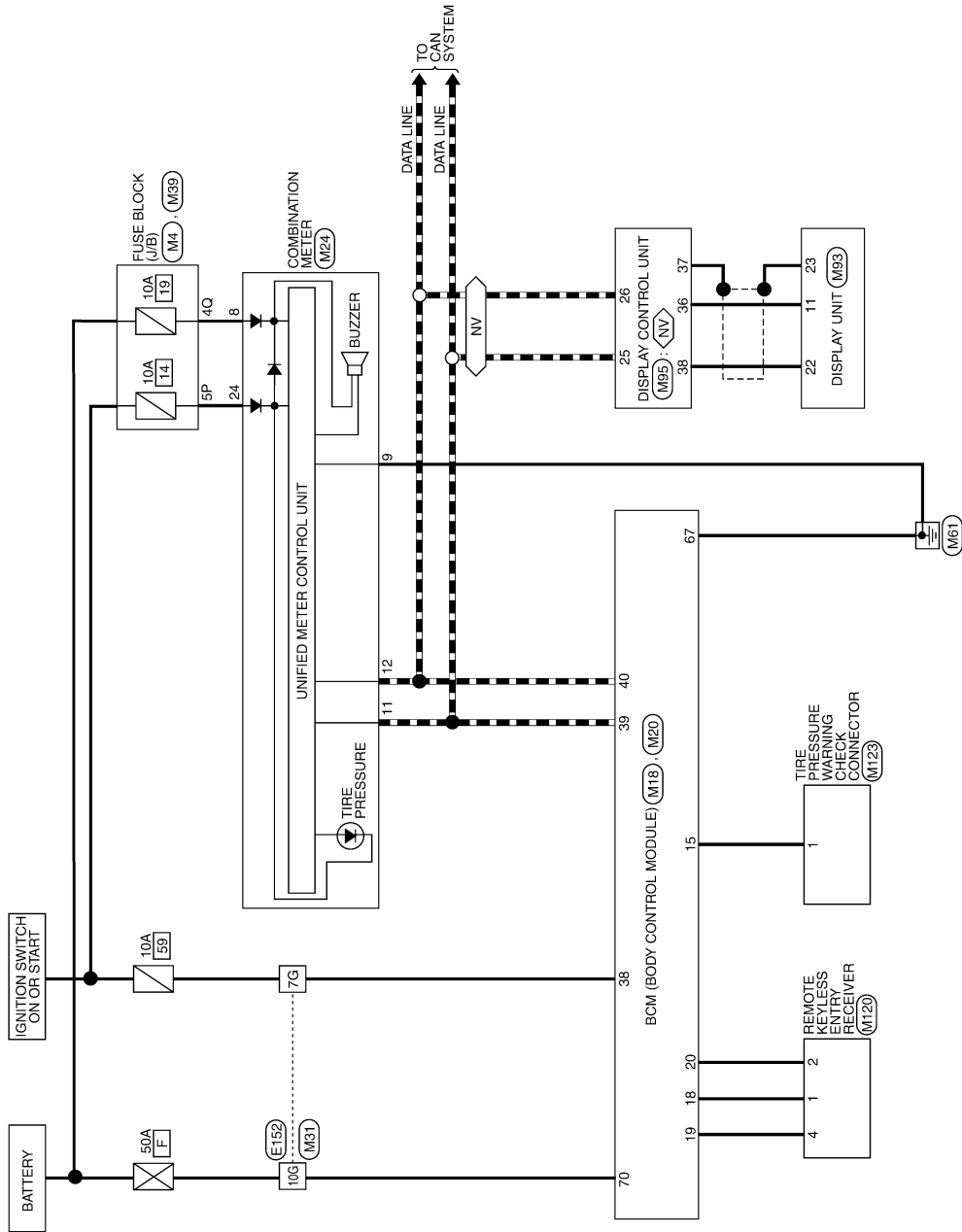

A
 B
 C
 D
 WT
 F
 G
 H
 I
 J
 K
 L
 M
 N
 O
 P

BCM (BODY CONTROL MODULE)

< ECU DIAGNOSIS >

TIRE PRESSURE MONITORING SYSTEM CONNECTORS

Connector No.	M4
Connector Name	FUSE BLOCK (J/B)
Connector Color	WHITE



Terminal No.	Color of Wire	Signal Name
5P	O/L	-

Connector No.	M18
Connector Name	BCM (BODY CONTROL MODULE)
Connector Color	WHITE

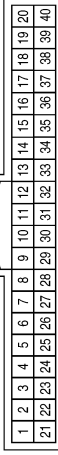

Terminal No.	Color of Wire	Signal Name
15	L/W	TPMS
18	P	SIG GND
19	V/W	KEYLESS PWR TUNER
20	G/W	KEYLESS TUNER SIGNAL
38	W/L	IGN SW
39	L	CAN-H
40	P	CAN-L

Connector No.	M20
Connector Name	BCM (BODY CONTROL MODULE)
Connector Color	BLACK



Terminal No.	Color of Wire	Signal Name
67	B	GND (POWER)
70	W/B	BATT (FL)

Connector No.	M24
Connector Name	COMBINATION METER
Connector Color	WHITE

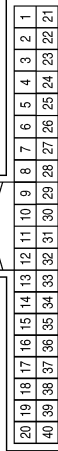

Terminal No.	Color of Wire	Signal Name
8	Y/R	-
9	B	-
11	L	CAN-H
12	P	CAN-L
24	O/L	-

Connector No.	M31
Connector Name	WIRE TO WIRE
Connector Color	WHITE

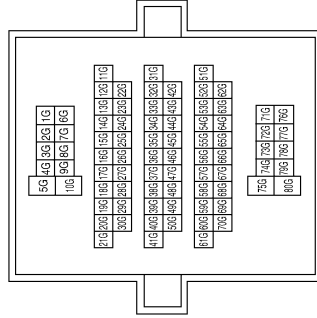

Terminal No.	Color of Wire	Signal Name
7G	W/L	-
10G	W/B	-

AWEIA0005GB

BCM (BODY CONTROL MODULE)

< ECU DIAGNOSIS >

Connector No.	M95
Connector Name	DISPLAY CONTROL UNIT
Connector Color	WHITE



26	28	30	32	34	36	38	40	42	44	46	48	50	52	54	56
25	27	29	31	33	35	37	39	41	43	45	47	49	51	53	55

Terminal No.	Color of Wire	Signal Name
25	L	CAN-H
26	P	CAN-L
36	B/W	DCU-DSP
37	SHIELD	-
38	L	DSP-DCU

Connector No.	M93
Connector Name	DISPLAY UNIT
Connector Color	WHITE



12	11	10	9	8	7	6	5	4	3	2	1
24	23	22	21	20	19	18	17	16	15	14	13

Terminal No.	Color of Wire	Signal Name
11	B/W	DCU-DPS
22	L	DSP-DCU
23	SHIELD	-

Connector No.	M39
Connector Name	FUSE BLOCK (J/B)
Connector Color	WHITE



30	20	10
60	70	80
90	50	40

Terminal No.	Color of Wire	Signal Name
4Q	Y/R	-

Connector No.	E152
Connector Name	WIRE TO WIRE
Connector Color	WHITE

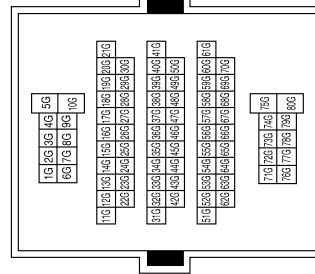

Connector No.	M123
Connector Name	TIRE PRESSURE WARNING CHECK CONNECTOR
Connector Color	WHITE



2	1
---	---

Terminal No.	Color of Wire	Signal Name
1	L/W	TPMS_TRIGGER_SW

Connector No.	M120
Connector Name	REMOTE KEYLESS ENTRY RECEIVER
Connector Color	WHITE



1	2	3	4
---	---	---	---

Terminal No.	Color of Wire	Signal Name
1	P	GND
2	G/W	SIGNAL
4	V/W	POWER

Terminal No.	Color of Wire	Signal Name
7G	L/W	-
10G	W/B	-

Self-Diagnosis

FUNCTION

Self-Diagnostic Results Mode

AWEIA0006GB

INFOID:000000001663805

A
B
C
D
WT
F
G
H
I
J
K
L
M
N
O
P

BCM (BODY CONTROL MODULE)

< ECU DIAGNOSIS >

Diagnostic item	Diagnostic item is detected when ...	Reference page
LOW - PRESSURE - FL [C1704] LOW - PRESSURE - FR [C1705] LOW - PRESSURE - RR [C1706] LOW - PRESSURE - RL [C1707]	Tire pressures dropped below specified value. Refer to WT-8 , " System Description ".	—
[NO-DATA] - FL [C1708] [NO-DATA] - FR [C1709] [NO-DATA] - RR [C1710] [NO-DATA] - RL [C1711]	Data from FL transmitter cannot be received. Data from FR transmitter cannot be received. Data from RR transmitter cannot be received. Data from RL transmitter cannot be received.	WT-13
[CHECKSUM- ERR] - FL [C1712] [CHECKSUM- ERR] - FR [C1713] [CHECKSUM- ERR] - RR [C1714] [CHECKSUM- ERR] - RL [C1715]	Checksum data from FL transmitter is malfunctioning. Checksum data from FR transmitter is malfunctioning. Checksum data from RR transmitter is malfunctioning. Checksum data from RL transmitter is malfunctioning.	WT-15
[PRESSDATA- ERR] - FL [C1716] [PRESSDATA- ERR] - FR [C1717] [PRESSDATA- ERR] - RR [C1718] [PRESSDATA- ERR] - RL [C1719]	Air pressure data from FL transmitter is malfunctioning. Air pressure data from FR transmitter is malfunctioning. Air pressure data from RR transmitter is malfunctioning. Air pressure data from RL transmitter is malfunctioning.	WT-17
[CODE- ERR] - FL [C1720] [CODE- ERR] - FR [C1721] [CODE- ERR] - RR [C1722] [CODE- ERR] - RL [C1723]	Function code data from FL transmitter is malfunctioning. Function code data from FR transmitter is malfunctioning. Function code data from RR transmitter is malfunctioning. Function code data from RL transmitter is malfunctioning.	WT-15
[BATT - VOLT - LOW] - FL [C1724] [BATT - VOLT - LOW] - FR [C1725] [BATT - VOLT - LOW] - RR [C1726] [BATT - VOLT - LOW] - RL [C1727]	Battery voltage of FL transmitter drops. Battery voltage of FR transmitter drops. Battery voltage of RR transmitter drops. Battery voltage of RL transmitter drops.	WT-15
VHCL_SPEED_SIG_ERR [C1729]	Vehicle speed signal is in error.	WT-18

NOTE:

Before performing the self-diagnosis, be sure to register the ID or else the actual malfunction location may be different from that displayed on CONSULT-III.

Flash Code Chart

INFOID:000000001663806

NOTE:

Ground tire pressure warning check connector to initiate self-diagnosis without CONSULT-III.

Flash Code	Malfunction part	Reference page
15 16 17 18	Tire pressure dropped below specified value. Refer to WT-8 , " System Description ".	—
21 22 23 24	Transmitter no data (FL) Transmitter no data (FR) Transmitter no data (RR) Transmitter no data (RL)	WT-13
31 32 33 34	Transmitter checksum error (FL) Transmitter checksum error (FR) Transmitter checksum error (RR) Transmitter checksum error (RL)	WT-15
35 36 37 38	Transmitter pressure data error (FL) Transmitter pressure data error (FR) Transmitter pressure data error (RR) Transmitter pressure data error (RL)	WT-17
41 42 43 44	Transmitter function code error (FL) Transmitter function code error (FR) Transmitter function code error (RR) Transmitter function code error (RL)	WT-15

BCM (BODY CONTROL MODULE)

< ECU DIAGNOSIS >

Flash Code	Malfunction part	Reference page
45	Transmitter battery voltage low (FL)	WT-15
46	Transmitter battery voltage low (FR)	
47	Transmitter battery voltage low (RR)	
48	Transmitter battery voltage low (RL)	
52	Vehicle speed signal	WT-18

A

B

C

D

WT

F

G

H

I

J

K

L

M

N

O

P

TPMS

< SYMPTOM DIAGNOSIS >

SYMPTOM DIAGNOSIS

TPMS

Symptom Table

INFOID:000000001663807

Symptom	Reference
Low tire pressure warning lamp does not come on when ignition switch is turned on.	WT-25
Low tire pressure warning lamp stays on when ignition switch is turned on.	WT-26
Low tire pressure warning lamp flashes when ignition switch is turned on.	WT-27
Hazard warning lamps flash when ignition switch is turned on.	WT-28
Tire pressure information in display unit does not exist.	WT-30
ID registration cannot be completed.	WT-30

LOW TIRE PRESSURE WARNING LAMP DOES NOT TURN ON

< SYMPTOM DIAGNOSIS >

LOW TIRE PRESSURE WARNING LAMP DOES NOT TURN ON

Low Tire Pressure Warning Lamp Does Not Come On When Ignition Switch Is Turned On

INFOID:000000001663808

DIAGNOSTIC PROCEDURE

1.SELF-DIAGNOSTIC RESULT CHECK

Using CONSULT-III, check display contents of BCM in SELF-DIAGNOSIS.

Is "CAN COMM CIRCUIT" displayed in the self-diagnosis display items?

YES >> Malfunction in CAN communication system. Refer to [LAN-57. "CAN System Specification Chart"](#).

NO >> GO TO 2

2.CHECK COMBINATION METER

Check combination meter operation. Refer to [MWI-27. "CONSULT-III Function \(METER/M&A\)"](#).

Inspection results OK?

YES >> GO TO 3

NO >> Replace combination meter. Refer to [MWI-72. "Removal and Installation"](#).

3.CHECK LOW TIRE PRESSURE WARNING LAMP

Disconnect BCM harness connector.

Does the low tire pressure warning lamp activate?

YES >> Replace BCM. Refer to [BCS-50. "Removal and Installation"](#).

NO >> Check combination meter operation.

A
B
C
D
WT
F
G
H
I
J
K
L
M
N
O
P

LOW TIRE PRESSURE WARNING LAMP STAYS ON

< SYMPTOM DIAGNOSIS >

LOW TIRE PRESSURE WARNING LAMP STAYS ON

Low Tire Pressure Warning Lamp Stays On When Ignition Switch Is Turned On

INFOID:000000001663809

DIAGNOSTIC PROCEDURE

1. BCM CONNECTORS

1. Turn ignition switch OFF.
2. Disconnect BCM harness connectors.
3. Check terminals for damage or loose connections.

Are any of the BCM connectors loose or damaged?

- YES >> Repair or replace damaged parts.
NO >> GO TO 2

2. BCM POWER SUPPLY AND GROUND CIRCUITS

Check BCM power supply and ground circuits. Refer to [BCS-29. "Diagnosis Procedure"](#).

Are the BCM power supply and ground circuits OK?

- YES >> Replace BCM. Refer to [BCS-50. "Removal and Installation"](#).
NO >> Repair BCM circuits.

LOW TIRE PRESSURE WARNING LAMP BLINKS

< SYMPTOM DIAGNOSIS >

LOW TIRE PRESSURE WARNING LAMP BLINKS

Low Tire Pressure Warning Lamp Flashes When Ignition Switch Is Turned On

INFOID:000000001663810

NOTE:

If low tire pressure warning lamp flashes as shown, the system is normal.

Flash Mode A

- This mode shows transmitter status is OFF-mode.
Carry out transmitter wake up operation. Refer to [WT-5, "Transmitter Wake Up Operation"](#).

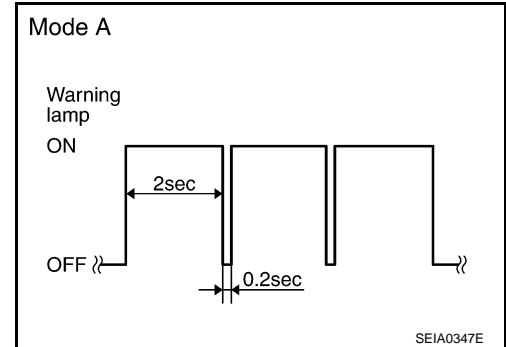

DIAGNOSTIC PROCEDURE

1. CHECK BCM CONNECTORS

1. Turn ignition switch OFF.
2. Disconnect BCM harness connectors.
3. Check terminals for damage or loose connections.

Inspection results OK?

YES >> GO TO 2

NO >> Repair or replace damaged parts.

2. CHECK TIRE PRESSURE WARNING CHECK CONNECTOR CIRCUIT

Check continuity between BCM harness connector M18 terminal 15 and ground.

Continuity should not exist.

Does continuity exist?

YES >> Repair circuit for short to ground.

NO >> Replace BCM. Refer to [BCS-50, "Removal and Installation"](#).

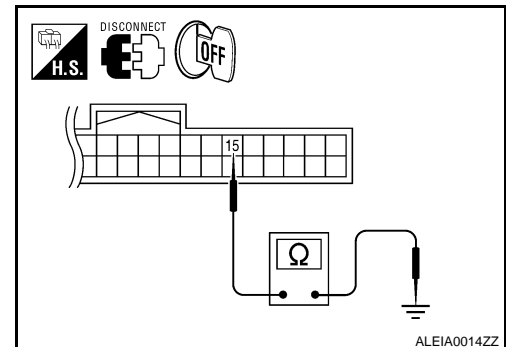

HAZARD WARNING LAMPS FLASH

< SYMPTOM DIAGNOSIS >

HAZARD WARNING LAMPS FLASH

Hazard Warning Lamps Flash When Ignition Switch Is Turned On

INFOID:000000001663811

DIAGNOSTIC PROCEDURE

1. CHECK BCM GROUND CIRCUIT

Check BCM ground circuit. Refer to [BCS-29, "Diagnosis Procedure"](#).

Is BCM ground circuit OK?

- YES >> Replace BCM. Refer to [BCS-50, "Removal and Installation"](#).
- NO >> Repair BCM ground circuit.

"TIRE PRESSURE" INFORMATION IN DISPLAY UNIT DOES NOT EXIST

< SYMPTOM DIAGNOSIS >

"TIRE PRESSURE" INFORMATION IN DISPLAY UNIT DOES NOT EXIST

"TIRE PRESSURE" Information in Display Unit Does Not Exist

INFOID:000000001663812

DIAGNOSTIC PROCEDURE

1. SELF-DIAGNOSTIC RESULT CHECK

Using CONSULT-III, check display contents in self-diagnostic results.

Is "CAN COMM CIRCUIT" displayed in the self-diagnosis display items?

YES >> Malfunction in CAN communication system.

NO >> GO TO 2.

2. CHECK DISPLAY UNIT

Perform display unit self-diagnosis. Refer to [AV-222. "AUDIO UNIT : Diagnosis Description"](#).

Inspection results OK?

OK >> Replace BCM. Refer to [BCS-50. "Removal and Installation"](#).

NG >> Repair or replace malfunctioning parts.

A

B

C

D

WT

F

G

H

I

J

K

L

M

N

O

P

ID REGISTRATION CANNOT BE COMPLETED

< SYMPTOM DIAGNOSIS >

ID REGISTRATION CANNOT BE COMPLETED

ID Registration Cannot Be Completed

INFOID:000000001663813

DIAGNOSTIC PROCEDURE

1.PERFORM ID REGISTRATION OF ALL TRANSMITTERS

Carry out ID registration of all transmitters. Refer to [WT-6, "ID Registration Procedure"](#).

Can ID registration of all transmitters be completed?

YES >> Inspection End.

NO >> GO TO [WT-13, "Data from Transmitter Not Being Received"](#).

NOISE, VIBRATION, AND HARSHNESS (NVH) TROUBLESHOOTING

< SYMPTOM DIAGNOSIS >

NOISE, VIBRATION, AND HARSHNESS (NVH) TROUBLESHOOTING

NVH Troubleshooting Chart

INFOID:000000001346497

Use the chart below to help you find the cause of the symptom. If necessary, repair or replace these parts.

Symptom		Possible cause and SUSPECTED PARTS													Reference page		
		Out-of-round	Imbalance	Incorrect tire pressure	Uneven tire wear	Deformation or damage	Non-uniformity	Incorrect tire size	DIFFERENTIAL	FRONT AXLE AND FRONT SUSPENSION	REAR AXLE AND REAR SUSPENSION	TIRES	ROAD WHEEL	BRAKE		STEERING	
TIRES	Noise	x	x	x	x	x	x		x	x	x	x		x	x	WT-34 WT-35 WT-39 WT-36 — — WT-39 DLN-172, "NVH Troubleshooting Chart" (FFD), DLN-204, "NVH Troubleshooting Chart" (RFD) M226, DLN-237, "NVH Troubleshooting Chart" (RFD) M226 ELD FAX-4, "NVH Troubleshooting Chart" (FAX), FSU-4, "NVH Troubleshooting Chart" (FSU) RAX-4, "NVH Troubleshooting Chart" (RAX), RSU-4, "NVH Troubleshooting Chart" (RSU) Refer to TIRES in this chart. Refer to ROAD WHEEL in this chart. BR-5, "NVH Troubleshooting Chart" ST-6, "NVH Troubleshooting Chart"	
	Shake	x	x	x	x	x		x		x	x	x		x	x		
	Vibration			x				x		x	x	x			x		
	Shimmy	x	x	x	x	x	x	x		x	x	x		x	x		
	Shudder	x	x	x	x	x		x		x	x	x		x	x		
	Poor quality ride or handling	x	x	x	x	x		x		x	x	x					
	ROAD WHEEL	Noise	x	x			x			x	x	x		x	x		x
		Shake	x	x			x				x	x		x	x		x
Shimmy, shudder		x	x			x				x	x		x	x	x		
Poor quality ride or handling		x	x			x				x	x		x				

x: Applicable

A
B
C
D
E
F
G
H
I
J
K
L
M
N
O
P

WT

PRECAUTIONS

< PRECAUTION >

PRECAUTION

PRECAUTIONS

Precaution for Supplemental Restraint System (SRS) "AIR BAG" and "SEAT BELT PRE-TENSIONER"

INFOID:000000001346493

The Supplemental Restraint System such as "AIR BAG" and "SEAT BELT PRE-TENSIONER", used along with a front seat belt, helps to reduce the risk or severity of injury to the driver and front passenger for certain types of collision. This system includes seat belt switch inputs and dual stage front air bag modules. The SRS system uses the seat belt switches to determine the front air bag deployment, and may only deploy one front air bag, depending on the severity of a collision and whether the front occupants are belted or unbelted. Information necessary to service the system safely is included in the SR and SB section of this Service Manual.

WARNING:

- **To avoid rendering the SRS inoperative, which could increase the risk of personal injury or death in the event of a collision which would result in air bag inflation, all maintenance must be performed by an authorized NISSAN/INFINITI dealer.**
- **Improper maintenance, including incorrect removal and installation of the SRS, can lead to personal injury caused by unintentional activation of the system. For removal of Spiral Cable and Air Bag Module, see the SR section.**
- **Do not use electrical test equipment on any circuit related to the SRS unless instructed to in this Service Manual. SRS wiring harnesses can be identified by yellow and/or orange harnesses or harness connectors.**

Precaution for work

INFOID:000000001346494

- After removing and installing the opening/closing parts, be sure to carry out fitting adjustments to check their operation.
- Check the lubrication level, damage, and wear of each part. If necessary, grease or replace it.

PREPARATION

< PREPARATION >

PREPARATION

PREPARATION

Special Service Tool

INFOID:000000001346495

The actual shapes of Kent-Moore tools may differ from those of special service tools illustrated here.

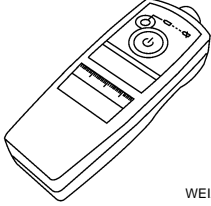
Tool number (Kent-Moore No.) Tool name	Description
KV991B1000 (J-45295) Transmitter activation tool  <p style="text-align: right;">WEIA0144E</p>	<ul style="list-style-type: none"> • Transmitter wake up operation • ID registration procedure

Commercial Service Tool

INFOID:000000001346496

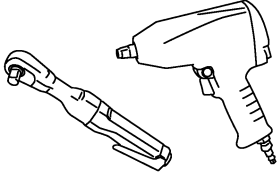
Tool name	Description
Power tool  <p style="text-align: right;">PBIC0190E</p>	Removing wheel nuts

WHEEL

< ON-VEHICLE MAINTENANCE >

ON-VEHICLE MAINTENANCE

WHEEL

Inspection

INFOID:000000001346510

1. Check tires for wear and improper inflation.
2. Check wheels for deformation, cracks and other damage. If deformed, remove wheel and check wheel runout.
 - a. Remove tire from wheel and mount wheel on a tire balance machine.
 - b. Set dial indicator as shown in the illustration. Refer to [WT-39](#), "[Road Wheel](#)".
3. Check front wheel bearings for looseness.
4. Check front suspension for looseness.

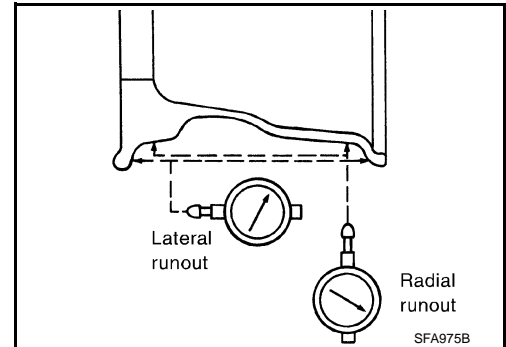

WHEEL AND TIRE ASSEMBLY

< ON-VEHICLE MAINTENANCE >

WHEEL AND TIRE ASSEMBLY

Balancing Wheels

INFOID:000000001346508

Removal

1. Remove inner and outer balance weights from the wheel.

CAUTION:

Be careful not to scratch the wheel during removal.

2. Using releasing agent, remove double-faced adhesive tape from the wheel.

CAUTION:

After removing double-faced adhesive tape, wipe clean traces of releasing agent from the wheel.

Wheel Balance Adjustment

- If a tire balance machine has adhesion balance weight mode settings and drive-in weight mode setting, select and adjust a drive-in weight mode suitable for wheels.

1. Set wheel on wheel balancer using the center hole as a guide. Start the tire balance machine.
2. When inner and outer imbalance values are shown on the wheel balancer indicator, multiply outer imbalance value by 1.6 to determine balance weight that should be used. Select the outer balance weight with a value closest to the calculated value and install it to the designated outer position of, or at the designated angle in relation to the road wheel.

CAUTION:

- **Do not install the inner balance weight before installing the outer balance weight.**
- **Before installing the balance weight, be sure to clean the mating surface of the wheel.**

Indicated imbalance value $\times 5/3 =$ balance weight to be installed

Calculation example:

$23 \text{ g (0.81 oz)} \times 5/3 = 38.33 \text{ g (1.35 oz)} = 40 \text{ g (1.41 oz)}$ balance weight (closer to calculated balance weight value)

Note that balance weight value must be closer to the calculated balance weight value.

Example:

$37.4 \text{ g} = 35 \text{ g (1.23 oz)}$

$37.5 \text{ g} = 40 \text{ g (1.41 oz)}$

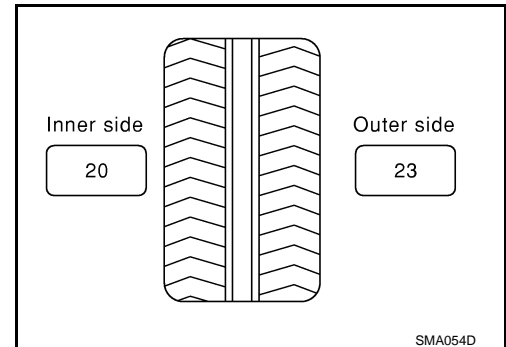

- a. Install balance weight in the position shown.
- b. When installing balance weight to wheels, set it into the grooved area on the inner wall of the wheel as shown so that the balance weight center is aligned with the wheel balancer indication position (angle).

CAUTION:

- **Always use Genuine NISSAN adhesion balance weights.**
- **Balance weights are not reusable; always replace with new ones.**
- **Do not install more than three sheets of balance weights.**

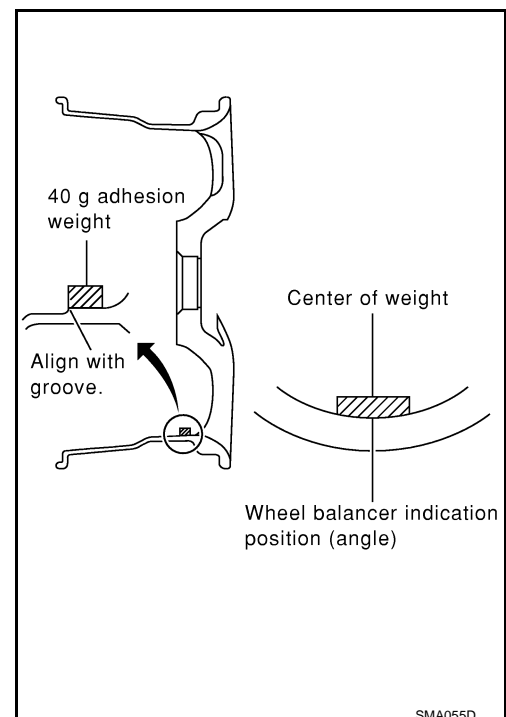

A
B
C
D
WT
F
G
H
I
J
K
L
M
N
O
P

WHEEL AND TIRE ASSEMBLY

< ON-VEHICLE MAINTENANCE >

- c. If calculated balance weight value exceeds 50 g (1.76 oz), install two balance weight sheets in line with each other as shown.

CAUTION:

Do not install one balance weight sheet on top of another.

3. Start wheel balancer again.
 4. Install drive-in balance weight on inner side of road wheel in the wheel balancer indication position (angle).

CAUTION:

Do not install more than two balance weights.

5. Start wheel balancer. Make sure that inner and outer residual imbalance values are 5 g (0.18 oz) each or below.

- If either residual imbalance value exceeds 5 g (0.18 oz), repeat installation procedures.

Wheel balance (Maximum allowable imbalance):

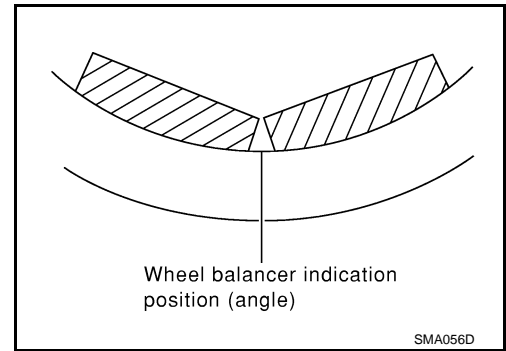

Maximum allowable imbalance	Dynamic (at rim flange)	5 g (0.18 oz) (one side)
	Static (at rim flange)	10 g (0.35 oz)

Rotation

INFOID:000000001346509

NOTE:

Follow the maintenance schedule for tire rotation service intervals. Refer to [MA-6. "Schedule 1"](#), [MA-8. "Schedule 2"](#).

1. Rotate the tires on each side from front to back as shown. Do not include the spare tire when rotating the tires.

Wheel nut : 133 N-m (14 kg-m, 98 ft-lb)

CAUTION:

When installing wheels, tighten them diagonally by dividing the work two to three times in order to prevent the wheels from developing any distortion.

2. Adjust the tire pressure to specification. Refer to [WT-39. "Tire"](#).
 3. After the tire rotation, retighten the wheel nuts after the vehicle has been driven for 1,000 km (600 miles), and also after every wheel and tire have been installed such as after repairing a flat tire.

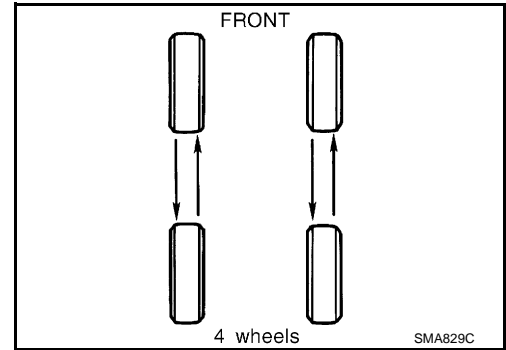

REMOVAL AND INSTALLATION

< REMOVAL AND INSTALLATION >

REMOVAL AND INSTALLATION

REMOVAL AND INSTALLATION

Transmitter (Pressure Sensor)

INFOID:000000001346500

REMOVAL

1. Deflate tire. Unscrew transmitter nut and allow transmitter to fall into tire.
2. Gently bounce tire so that transmitter falls to bottom of tire. Place wheel and tire assembly on tire changing machine and break both tire beads. Ensure that the transmitter remains at the bottom of the tire while breaking the bead.

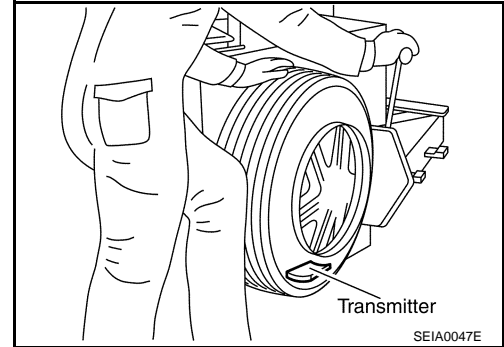

3. Turn tire so that valve hole is at bottom, and gently bounce the tire to ensure transmitter is near valve hole. Carefully lift tire onto turntable and position valve hole (and transmitter) 270 degrees from mounting/dismounting head.
4. Lubricate tire well, and remove top side of tire. Reach inside the tire and remove the transmitter.
5. Remove the second side of the tire as normal.

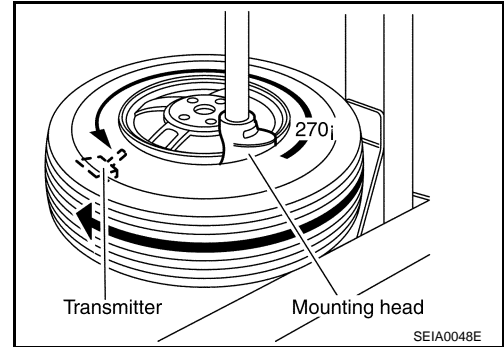

INSTALLATION

1. Place first side of tire onto rim.

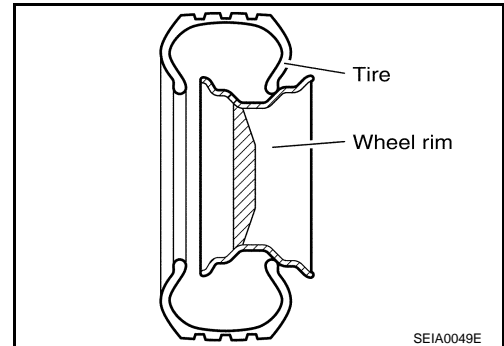

2. Mount transmitter on rim and tighten transmitter nut to specification.

Transmitter nut : 5.5 N-m (0.56 kg-m, 49 in-lb)

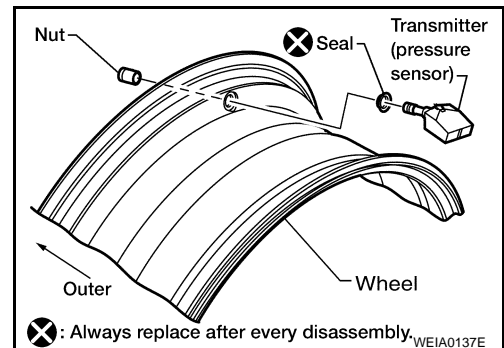

REMOVAL AND INSTALLATION

< REMOVAL AND INSTALLATION >

3. Place wheel on turntable of tire machine. Ensure that transmitter is 270 degrees from mounting/dismounting head.

NOTE:

Do not touch transmitter with mounting head.

4. Lubricate tire well, and install second side of tire as normal. Ensure that tire does not rotate relative to rim.
5. Inflate tire and balance wheel and tire assembly. Refer to [WT-35, "Balancing Wheels"](#).
6. Install wheel and tire assembly in appropriate wheel position on vehicle.

NOTE:

If replacing the transmitter, then transmitter wake up operation must be performed. Refer to [WT-5, "Transmitter Wake Up Operation"](#).

7. Adjust neutral position of steering angle sensor. Refer to [BRC-150, "ADJUSTMENT OF STEERING ANGLE SENSOR NEUTRAL POSITION : Special Repair Requirement"](#).

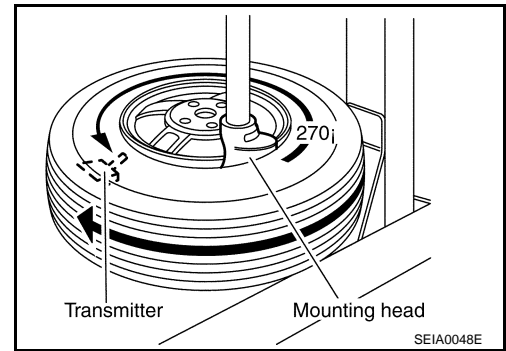

SERVICE DATA AND SPECIFICATIONS (SDS)

< SERVICE DATA AND SPECIFICATIONS (SDS)

SERVICE DATA AND SPECIFICATIONS (SDS)

SERVICE DATA AND SPECIFICATIONS (SDS)

Road Wheel

INFOID:0000000001346498

Wheel type		Aluminum	Steel	
			Inside	Outside
Maximum radial runout limit	Lateral mm (in)	0.3 (0.012) or less	1.0 (0.039) or less	0.9 (0.035) or less
	Radial mm (in)	0.3 (0.012) or less	0.8 (0.031) or less	0.4 (0.016) or less
Maximum allowable imbalance	Dynamic (at rim flange)	Less than 5 g (0.18 oz) (per side)		
	Static (at rim flange)	Less than 10 g (0.35 oz)		

Tire

INFOID:0000000001346499

Unit: kPa (kg/cm², psi)

Tire size	Air pressure	
	Conventional tire	Spare tire
Full size spare tire	—	240 (2.4, 35)
P265/70R18	240 (2.4, 35)	—
P275/70R18	240 (2.4, 35)	—
P275/60R20	240 (2.4, 35)	—