

ACCELERATOR CONTROL, FUEL & EXHAUST SYSTEMS

SECTION **FE**

CONTENTS

| | | |
|---|-------------------------------|-----------|
| ACCELERATOR CONTROL SYSTEM 2 | FUEL SYSTEM 3 | FE |
| Adjusting Accelerator Wire 2 | EXHAUST SYSTEM 5 | |

GE

MA

EM

LC

EF &
EC

FE

CL

MT

AT

TF

PD

FA

RA

BR

ST

BF

HA

EL

IDX

ACCELERATOR CONTROL SYSTEM

CAUTION:

- When removing accelerator wire, make a mark to indicate lock nut's initial position.
- Check that throttle valve opens fully when accelerator pedal is fully depressed and that it returns to idle position when pedal is released.
- Check accelerator control parts for improper contact with any adjacent parts.
- When connecting accelerator wire, be careful not to twist or scratch its inner wire.
- Refer to EL section for ASCD wire adjustment.
- For A/T throttle wire adjustment, refer to "ON-VEHICLE SERVICE" in AT section.

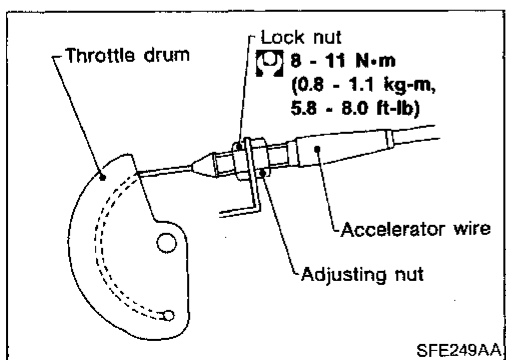
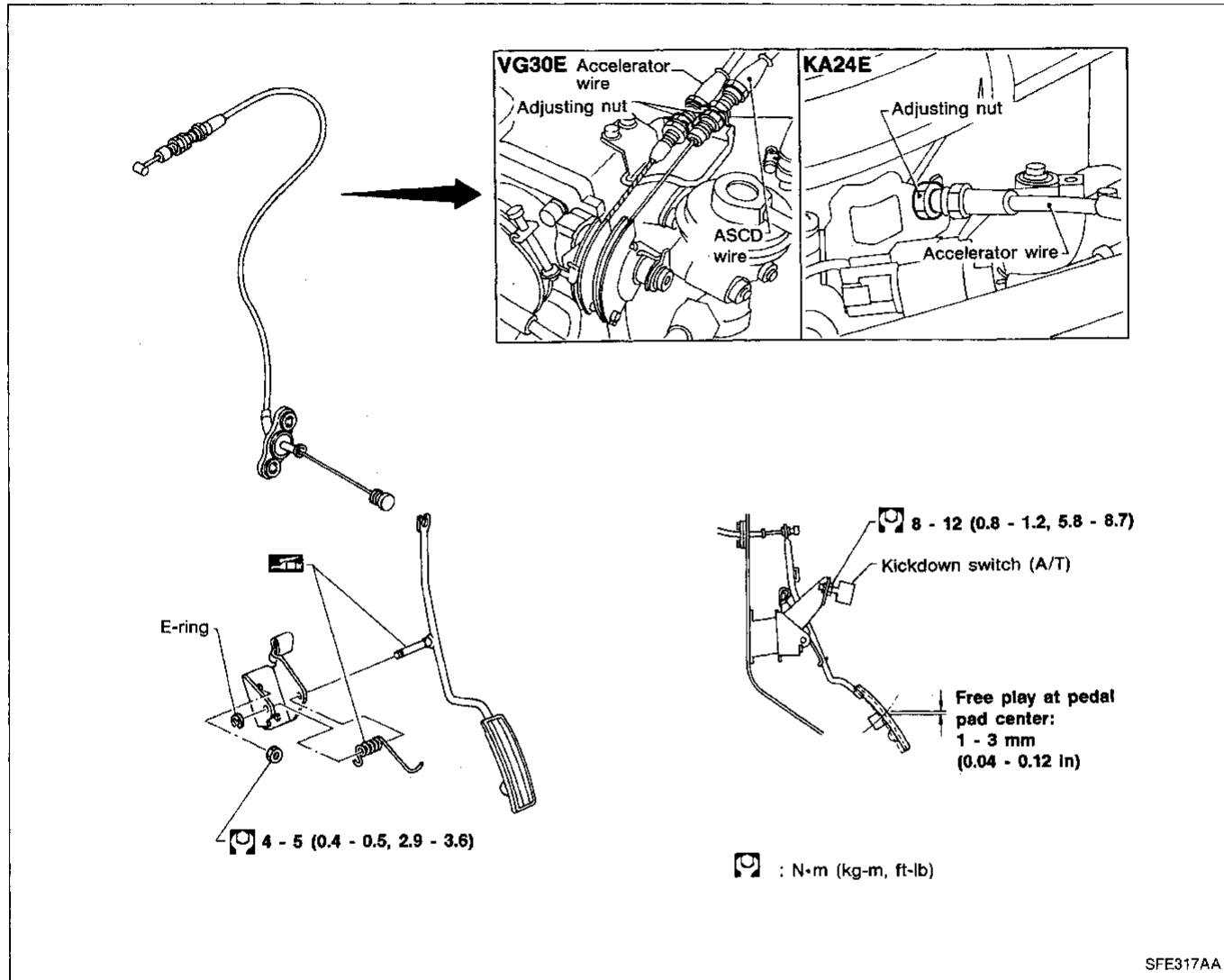

Adjusting Accelerator Wire

1. Loosen lock nut, and tighten adjusting nut until throttle drum starts to move.
2. From that position turn back adjusting nut 1.5 to 2 turns, and secure lock nut.

FUEL SYSTEM

WARNING:

When replacing fuel line parts, be sure to observe the following:

- Put a "CAUTION: INFLAMMABLE" sign in workshop.
- Do not smoke while servicing fuel system. Keep open flames and sparks away from work area.
- Be sure to furnish the workshop with a CO₂ fire extinguisher.
- Be sure to disconnect battery ground cable before conducting operations.
- Drain fuel from Fuel Tank and put drained fuel in an explosion-proof container and attach lid securely.

CAUTION:

- Before disconnecting fuel hose, release fuel pressure from fuel line. Refer to the "Changing Fuel Filter" in MA section.
- Do not disconnect any fuel line unless absolutely necessary.
- Plug hose and pipe openings to prevent entry of dust or dirt.
- Always replace O-ring with new ones.
- Do not kink or twist hose and tube when they are installed.
- Do not tighten hose clamps excessively to avoid damaging hoses.
- When installing fuel check valve, be careful of its designated direction. (Refer to EVAPORATIVE EMISSION SYSTEM in EF & EC section.)
- After installation, run engine and check for fuel leaks at connections.

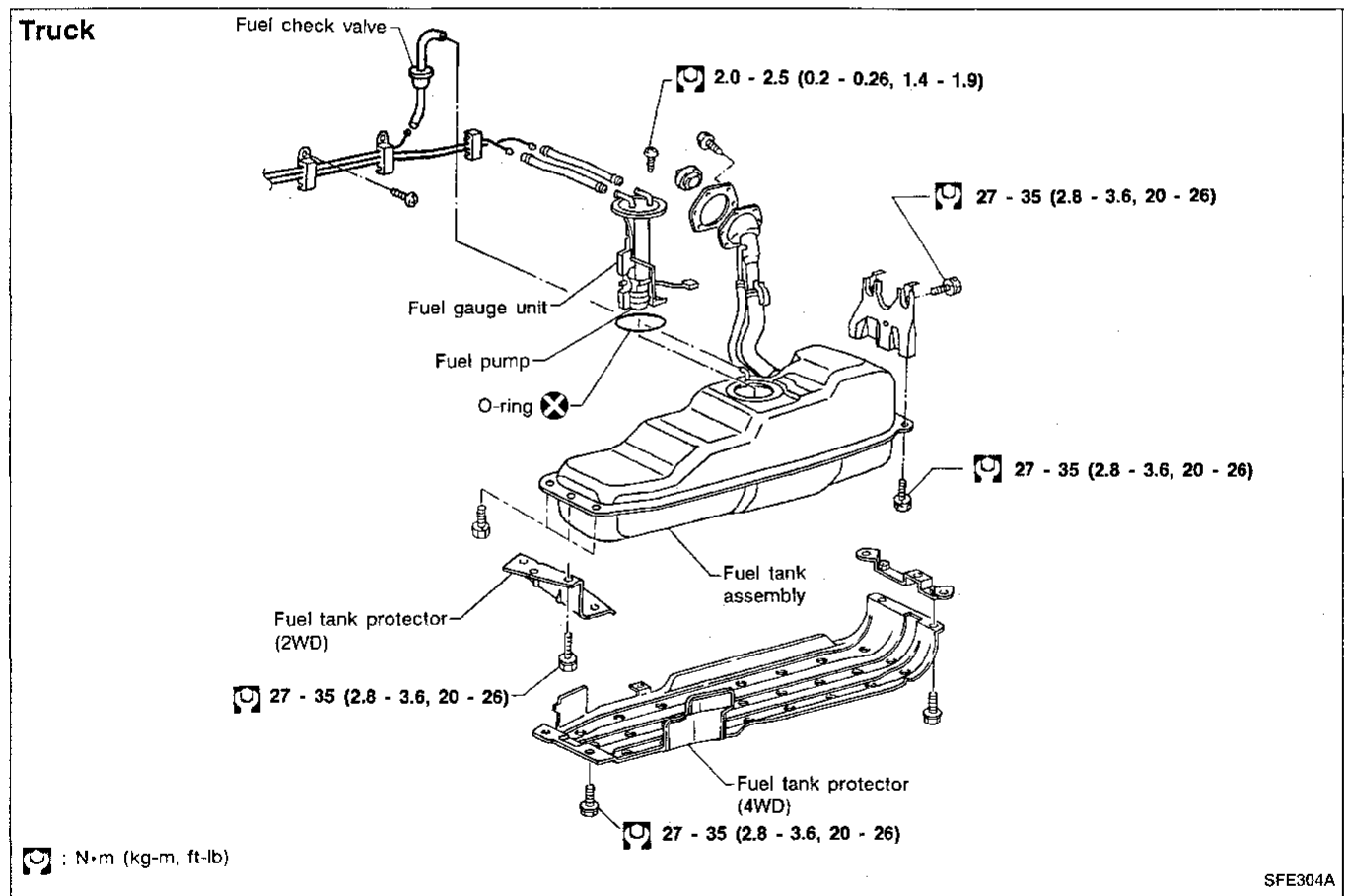

FUEL SYSTEM

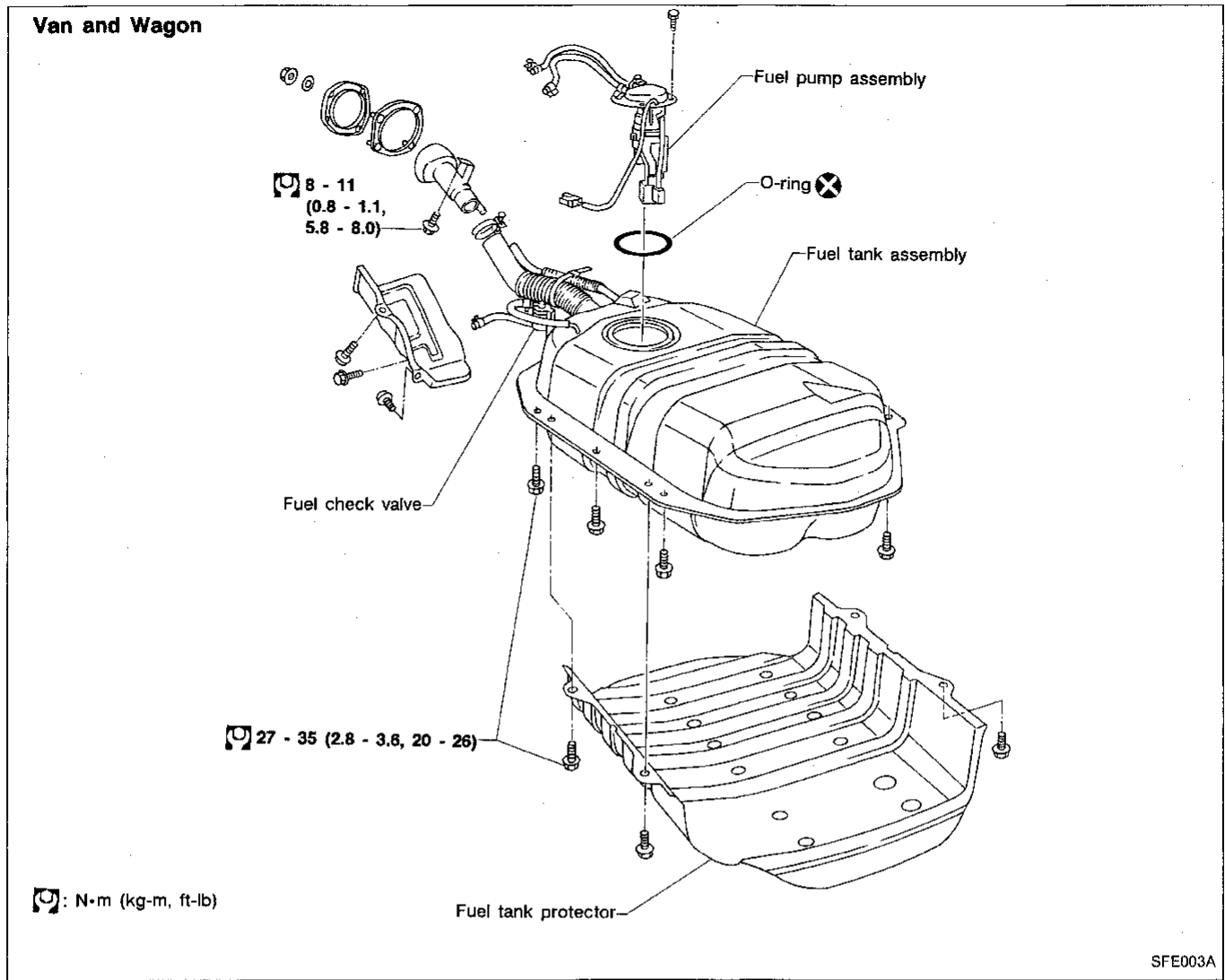

EXHAUST SYSTEM

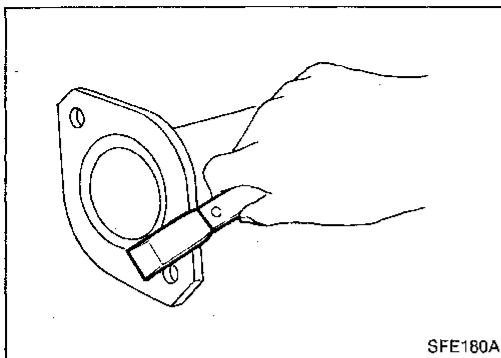

CAUTION:

- Always replace exhaust gaskets with new ones when reassembling. If gasket is left on flange surface, scrape off completely as shown at left.
- With engine running, check all tube connections for exhaust gas leaks, and entire system for unusual noises.
- After installation, check to ensure that mounting brackets and mounting insulators are free from undue stress. If any of the above parts are not installed properly, excessive noise or vibration may be transmitted to the vehicle body.

KA24E model (2WD)

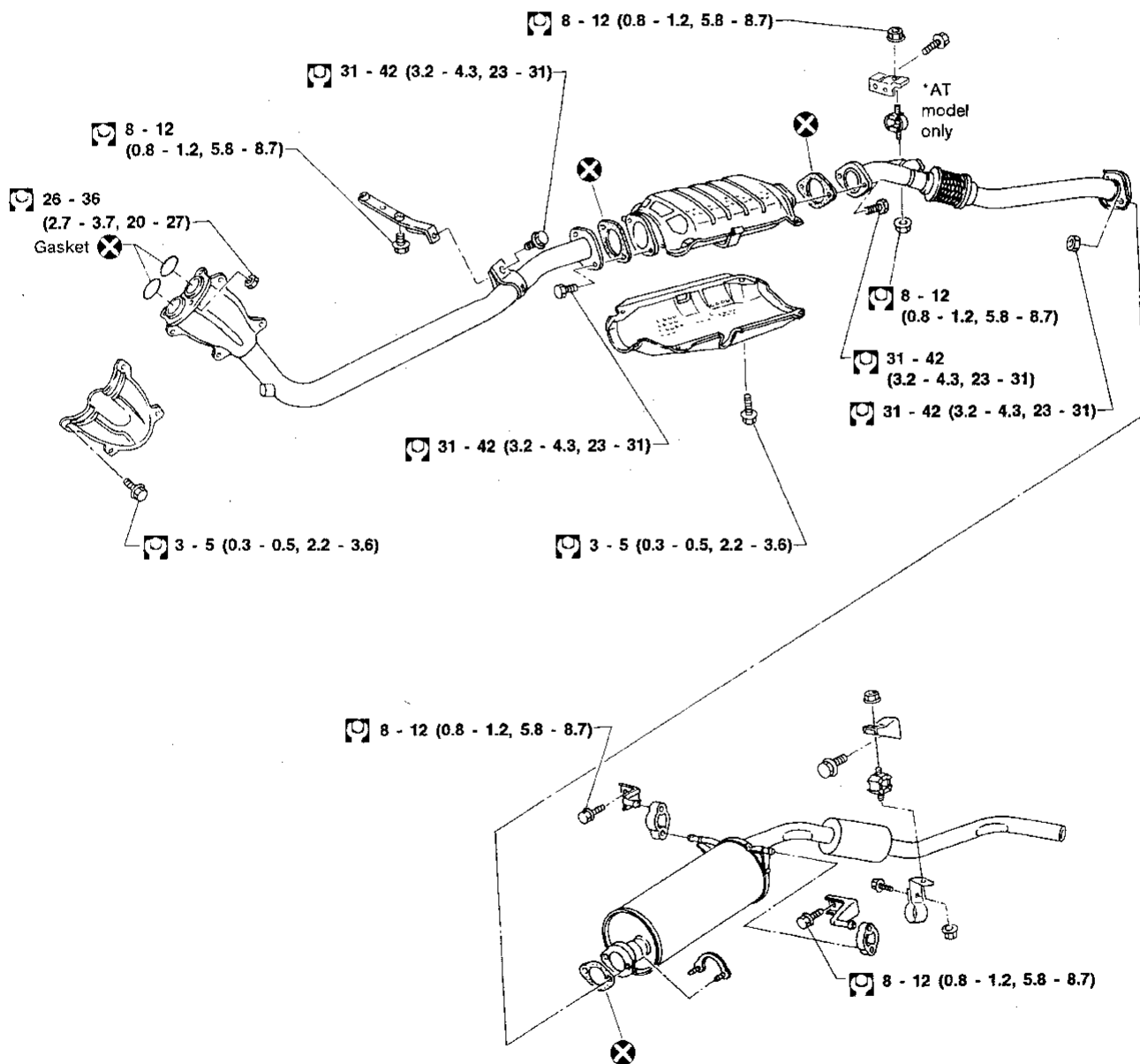

: N·m (kg-m, ft-lb)

SFE318A

GI

MA

EM

LC

EF &
EC

FE

CL

MT

AT

TF

PD

FA

RA

BR

ST

BF

HA

EL

IDX

EXHAUST SYSTEM

KA24E model (4WD)

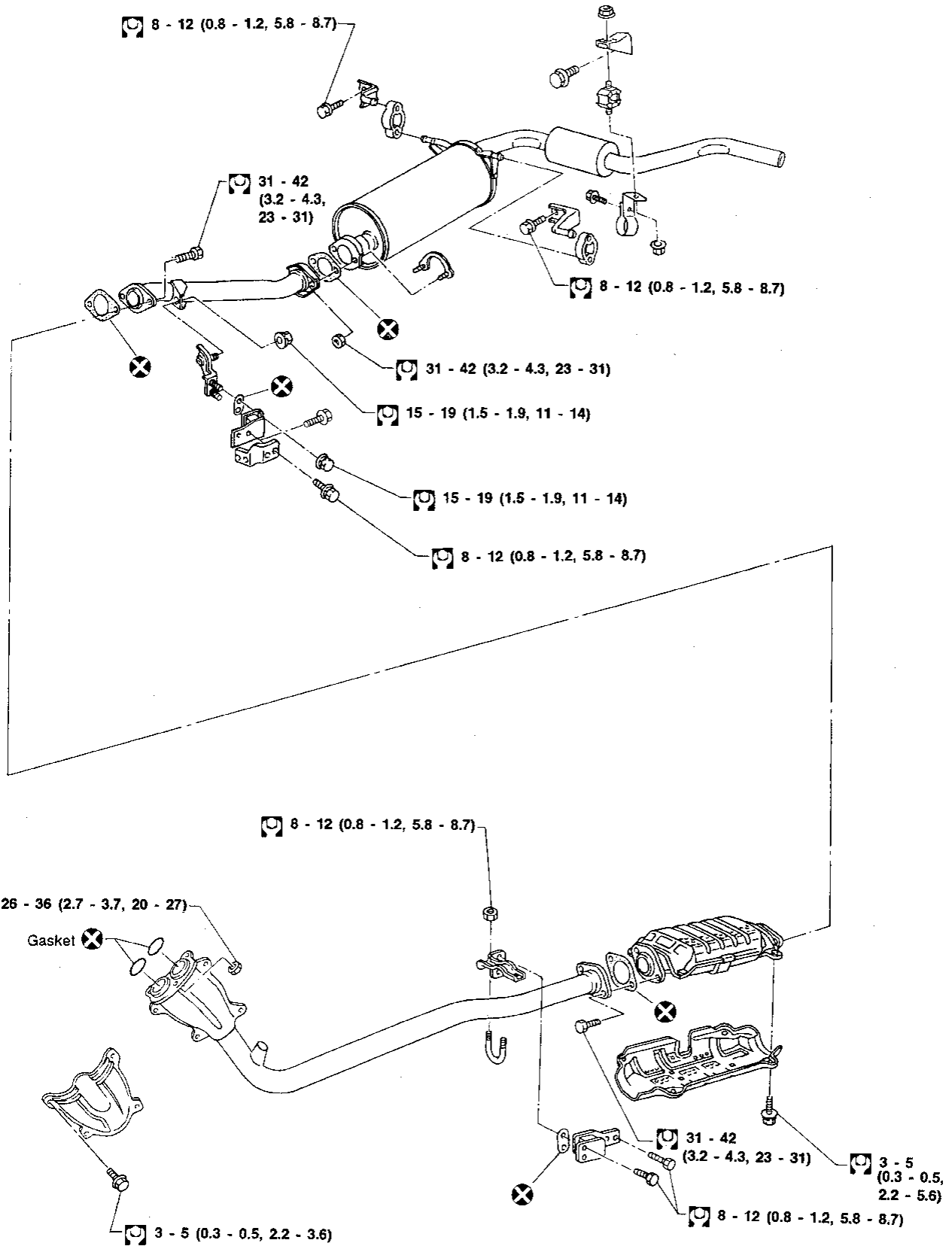

: N·m (kg·m, ft·lb)

SFE319A

FE-6

EXHAUST SYSTEM

VG30E model (4WD) for Truck

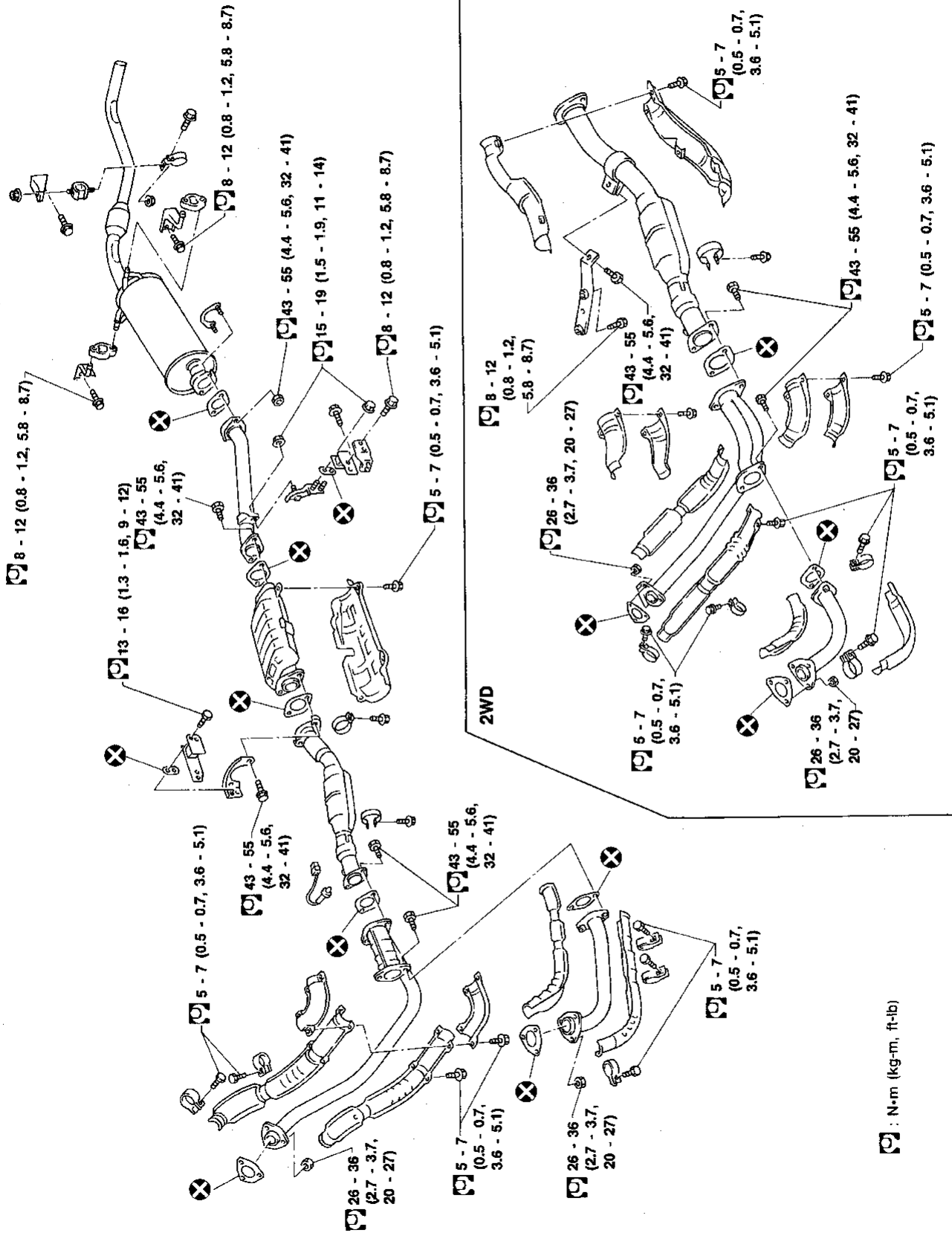

□ : N·m (kg·m, ft·lb)

- GI
- MA
- EM
- LC
- EF & EC
- FE**
- CL
- MT
- AT
- TF
- PD
- FA
- RA
- BR
- ST
- BF
- HA
- EL

FE-7

SFE351A

IDX

EXHAUST SYSTEM

VG30E model (4WD) for Wagon

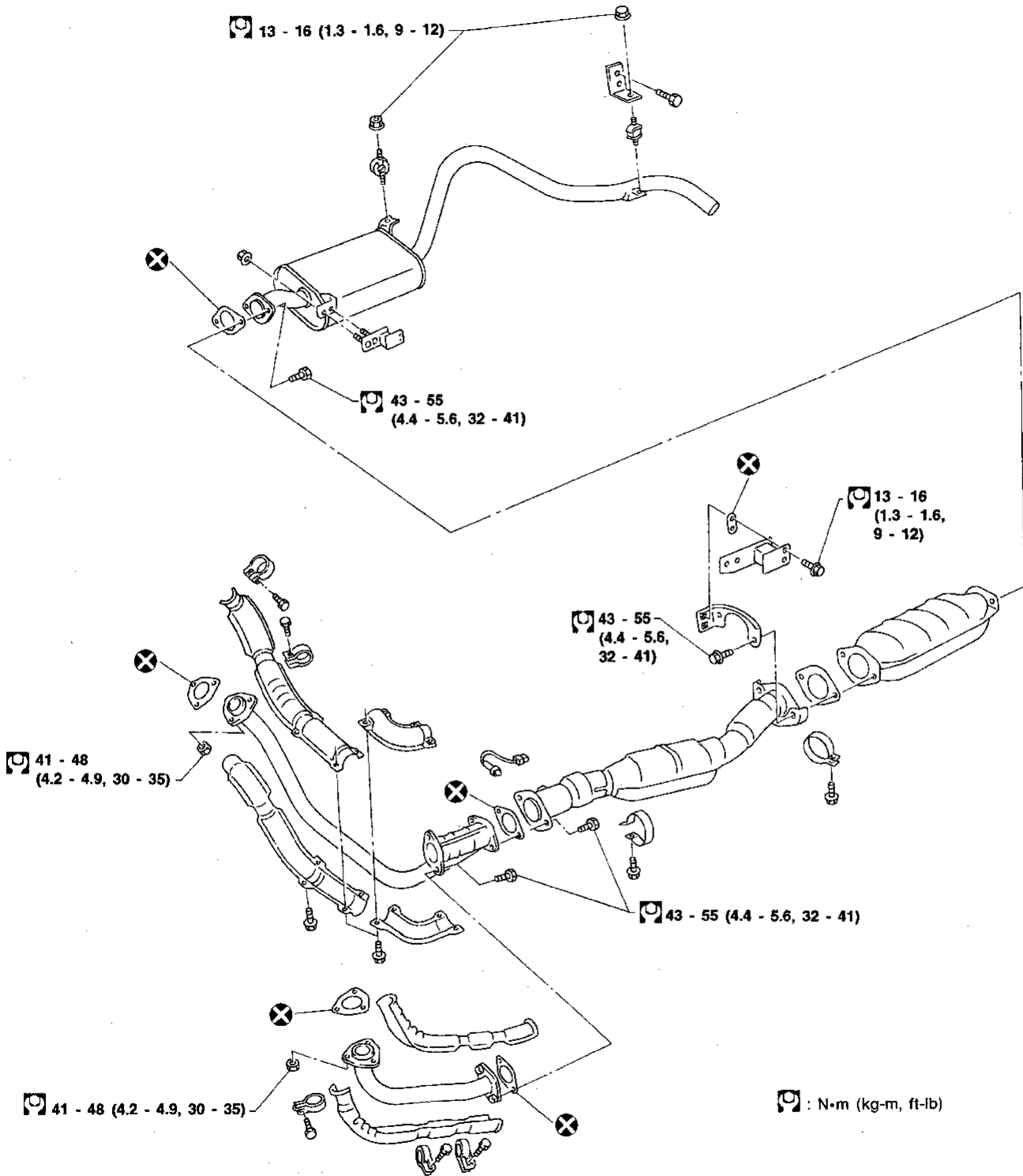

EXHAUST SYSTEM

VG30E model (2WD) for Wagon

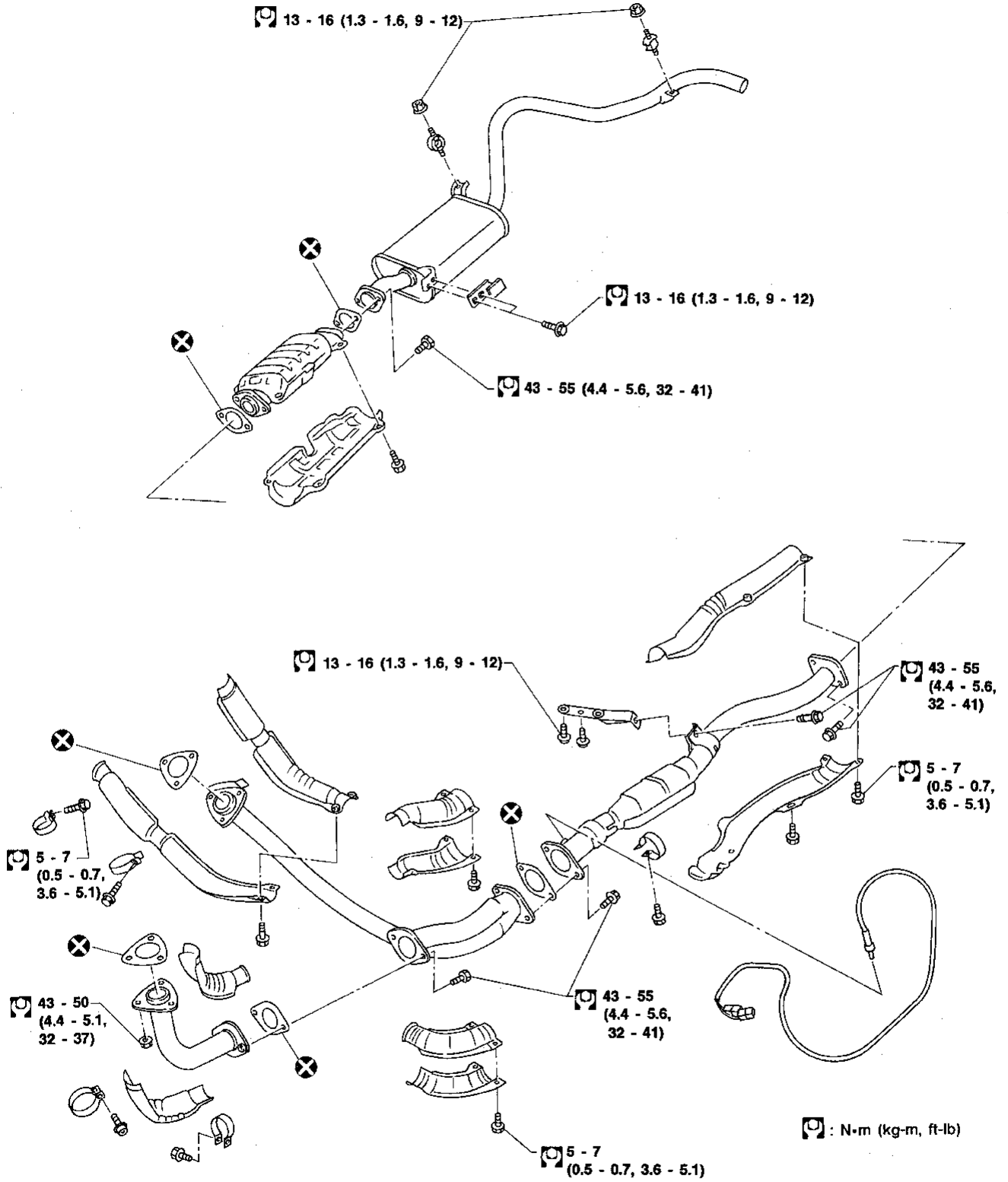

GI
MA
EM
LC
EF & EC
FE
CL
MT
AT
TF
PD
FA
RA
BR
ST
BF
HA
EL