

AUTOMATIC TRANSMISSION

SECTION **AT**

EF &
EC

AT

FA

BR

BF

HA

EL

CONTENTS

<input type="checkbox"/> RE4R01A <input type="checkbox"/>	Circuit Diagram	5
	Wiring Diagram	6
TRouble DIAGNOSES		2
Wiring Diagram		2
Circuit Diagram for Quick Pinpoint Check.....		4
<input type="checkbox"/> RE4R01A & RL4R01A <input type="checkbox"/>		
TRouble DIAGNOSES — A/T Shift Lock System		7
Circuit Diagram for Quick Pinpoint Check.....		7
Wiring Diagram		8
<input type="checkbox"/> RL4R01A <input type="checkbox"/>		
TRouble DIAGNOSES		5

Wiring Diagram

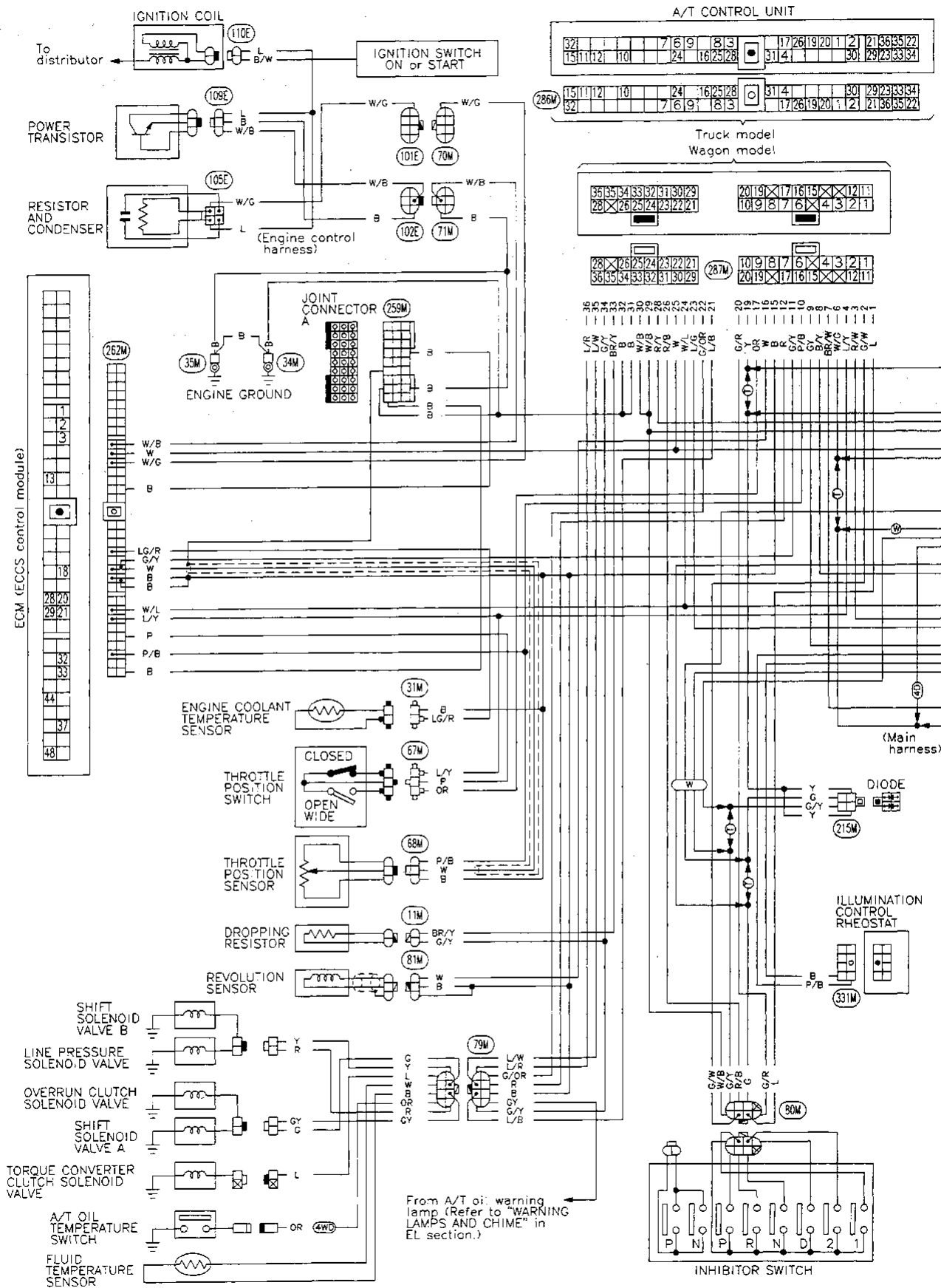

Wiring Diagram (Cont'd)

- (4WD) : 4-wheel drive model
- (W) : Wagon model
- (T) : Truck model
- (A) : A/T model
- (M) : M/T model
- (4D) : 4-door Wagor model

EF & EC

AT

FA

BR

BF

HA

EL

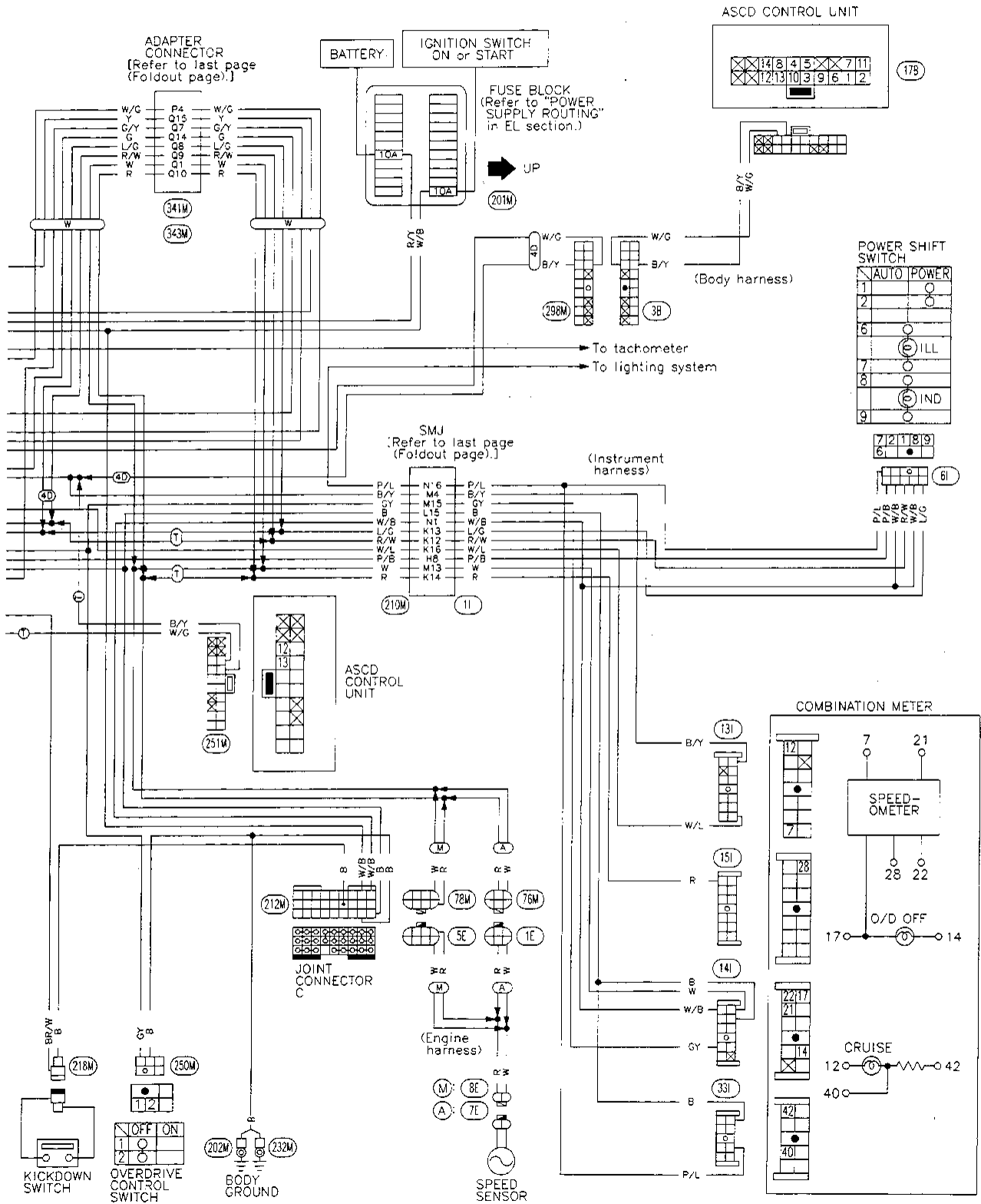

Circuit Diagram for Quick Pinpoint Check

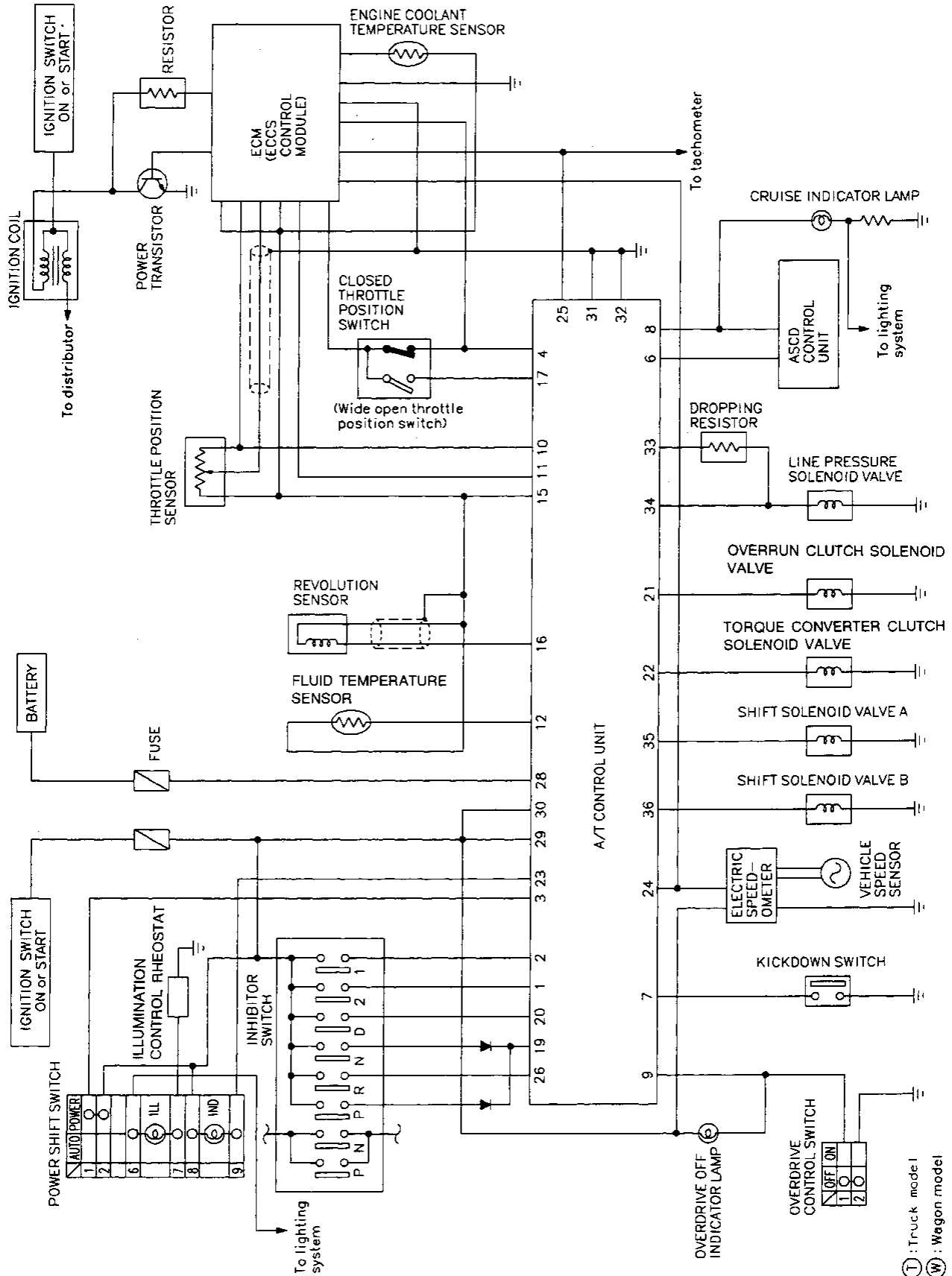

(T) : Truck model
 (W) : Wagon model
 SAT216H

Circuit Diagram

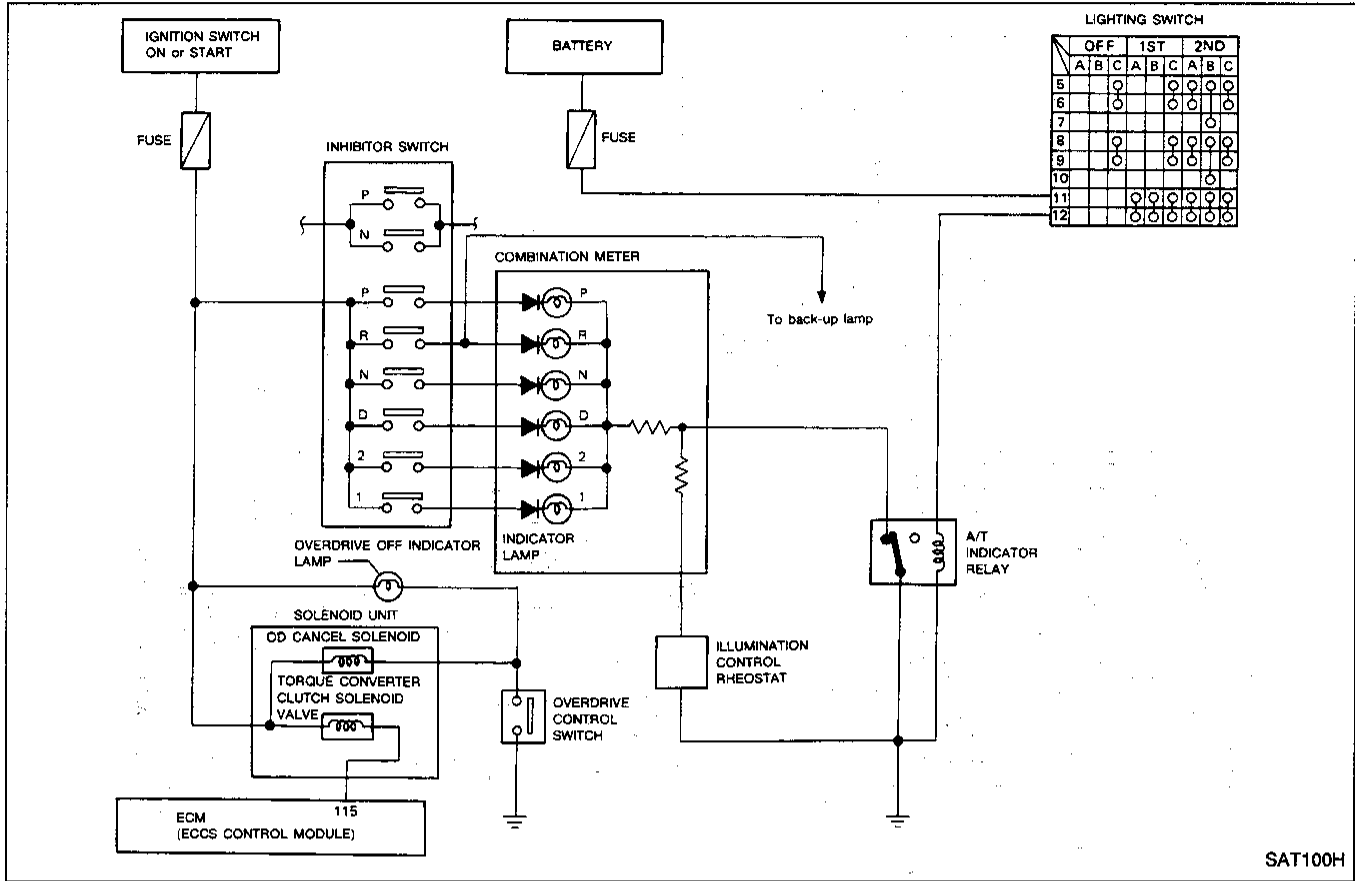

EF &
EC

AT

FA

BR

BF

HA

EL

SAT100H

Wiring Diagram

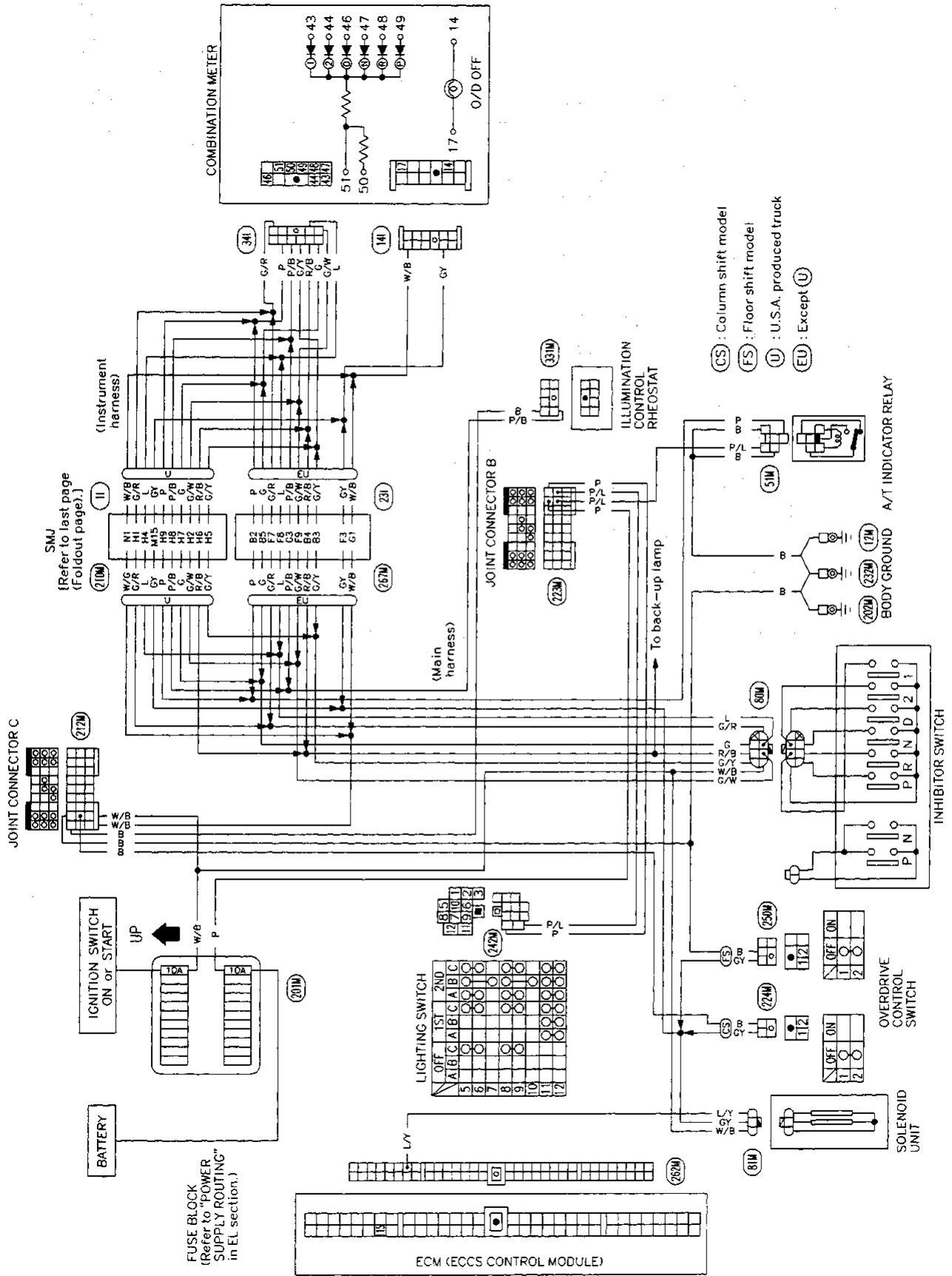

Circuit Diagram for Quick Pinpoint Check

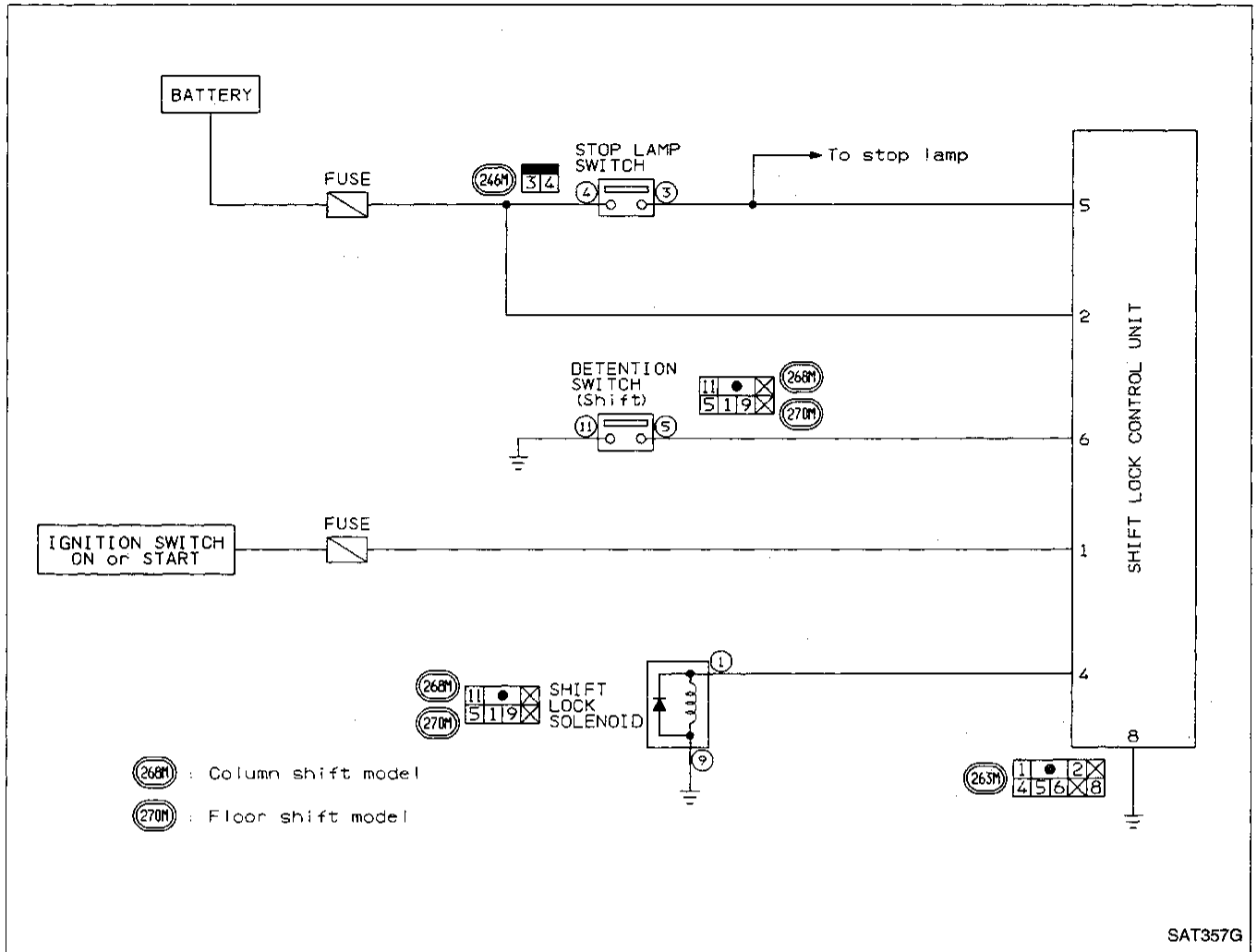

EF &
EC

AT

FA

BR

BF

HA

EL

TROUBLE DIAGNOSES — A/T Shift Lock System

Wiring Diagram

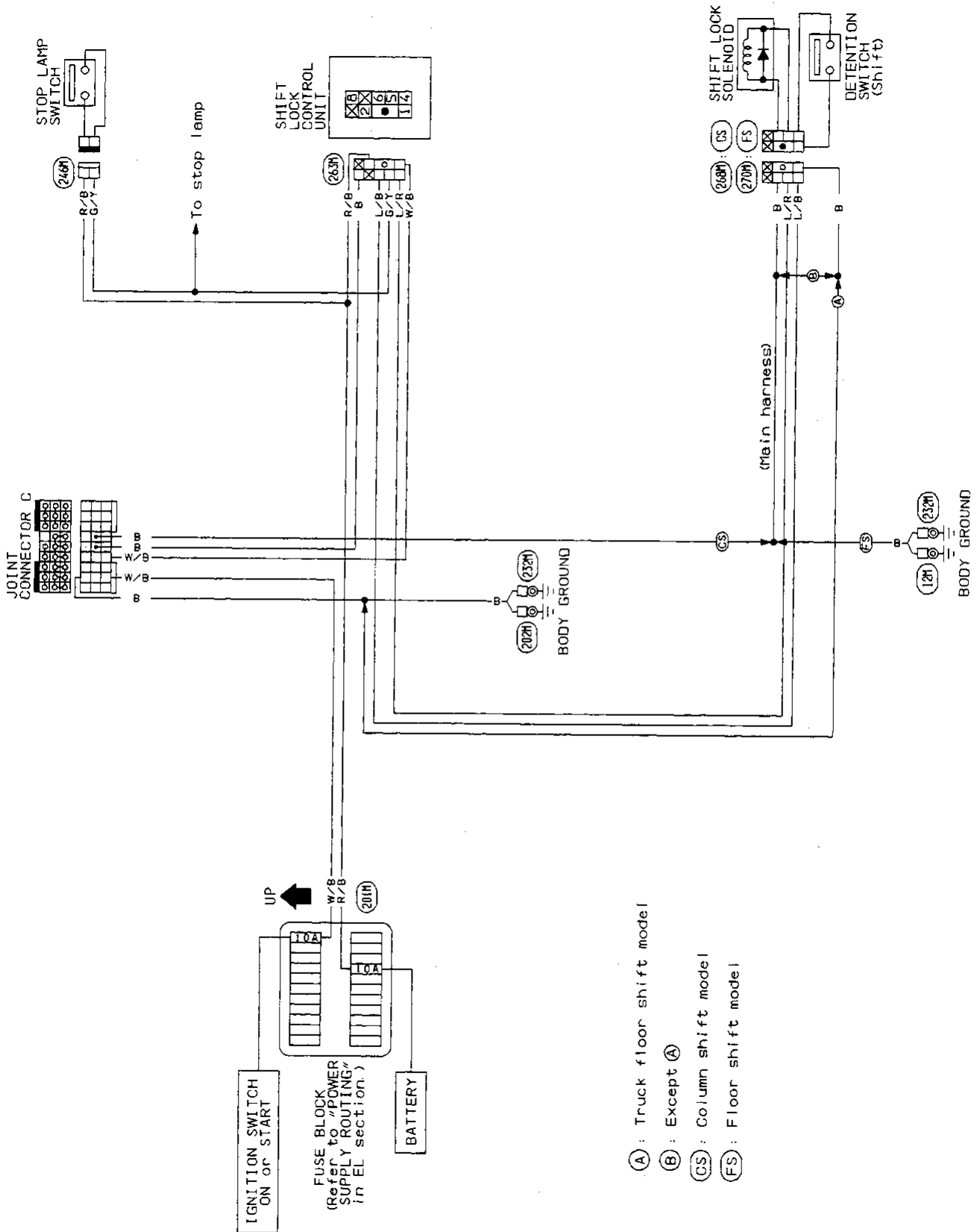

- (A) : Truck floor shift model
- (B) : Except (A)
- (CS) : Column shift model
- (FS) : Floor shift model