

SECTION BR

EF &
EC

AT

FA

BR

BF

HA

EL

CONTENTS

REAR WHEEL ANTI-LOCK BRAKE SYSTEM	2	TROUBLE DIAGNOSES	3
Wiring Diagram	2	Circuit Diagram for Quick Pinpoint Check.....	3

When you read wiring diagrams:

- Read GI section, "HOW TO READ WIRING DIAGRAMS".
- See EL section, "POWER SUPPLY ROUTING" for power distribution circuit.

When you perform trouble diagnoses, read GI section, "HOW TO FOLLOW FLOW CHART IN TROUBLE DIAGNOSES".

REAR WHEEL ANTI-LOCK BRAKE SYSTEM

Wiring Diagram

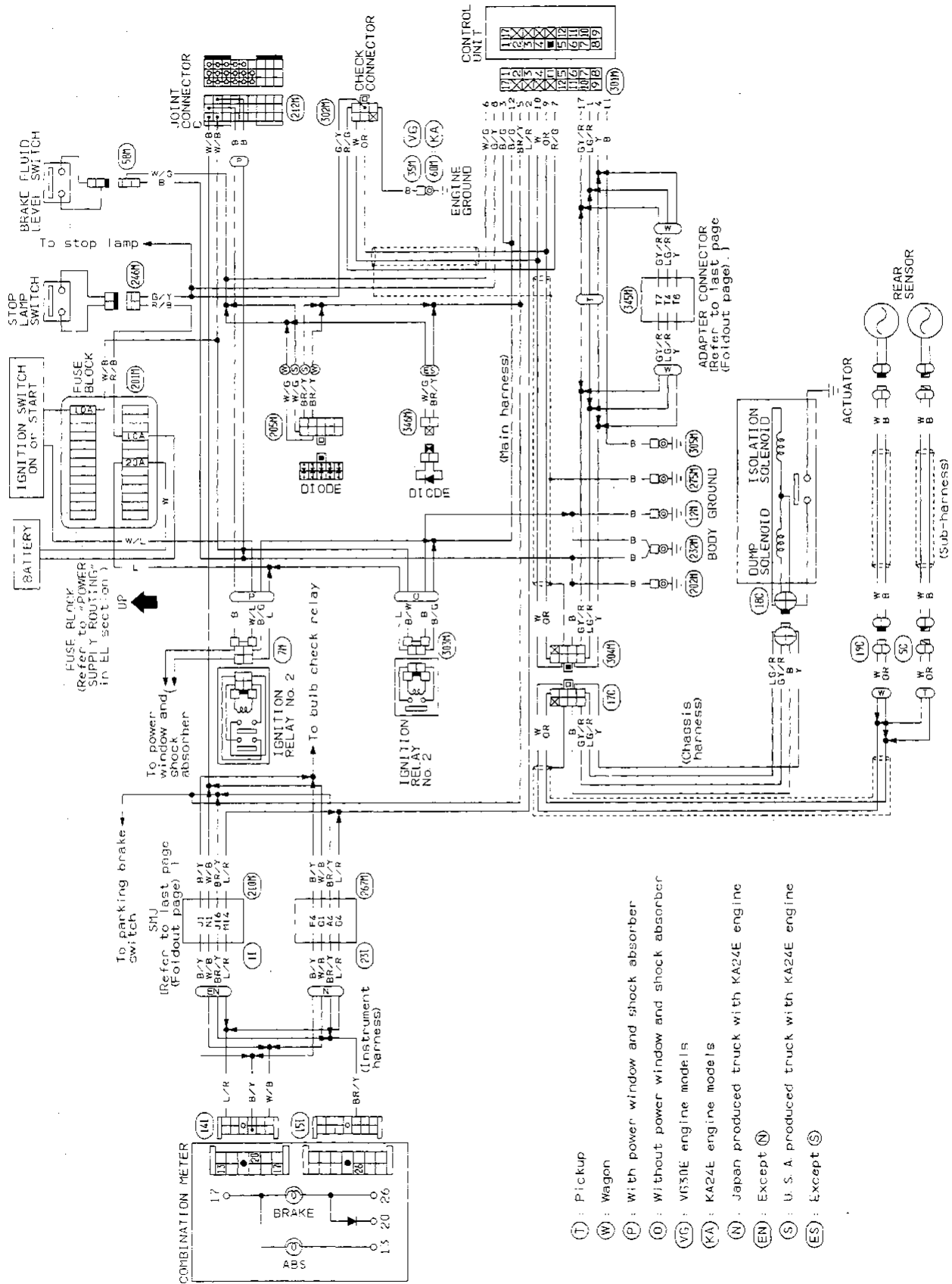

TROUBLE DIAGNOSES

Circuit Diagram for Quick Pinpoint Check

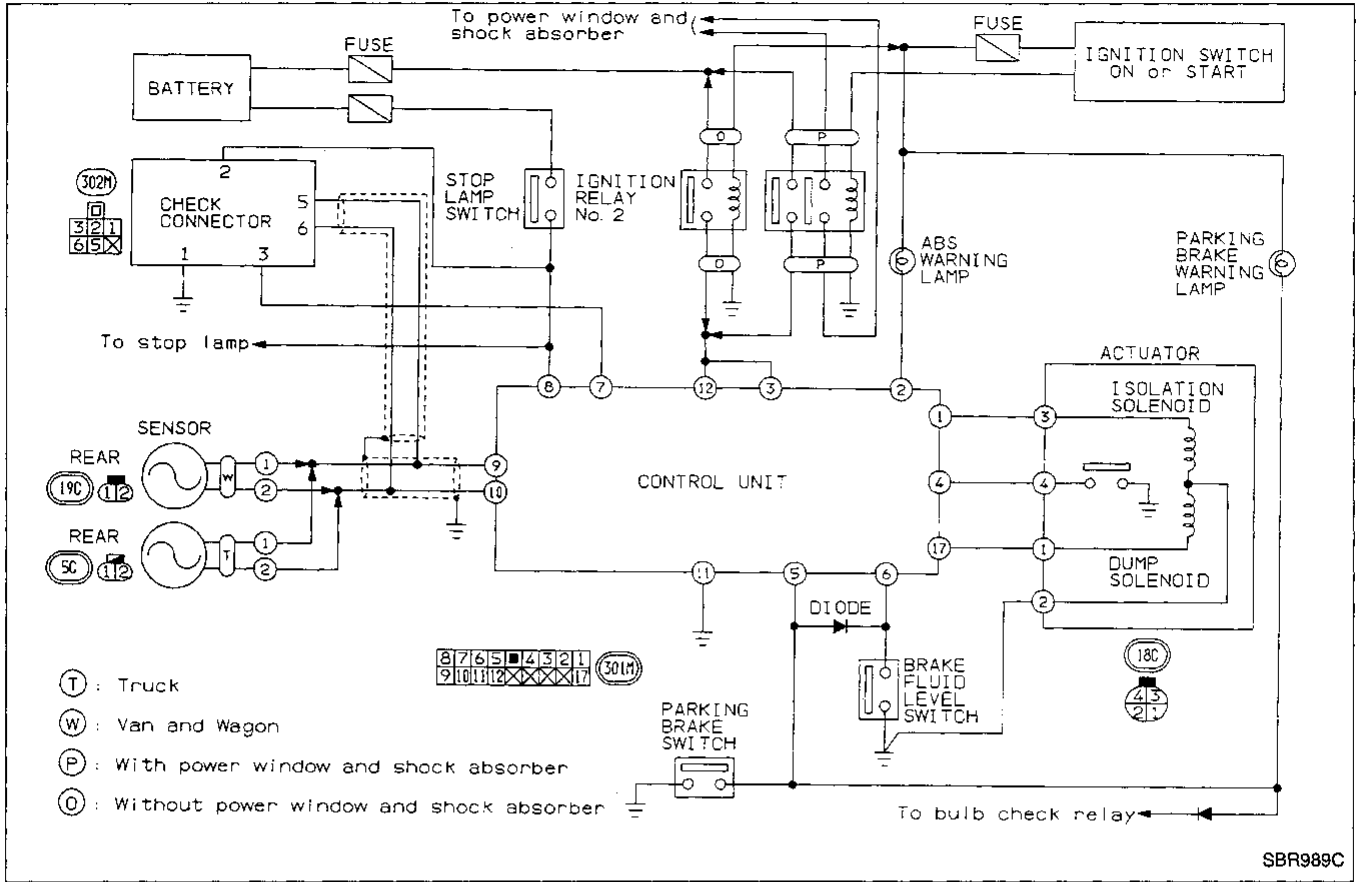

EF &
EC
AT
FA
BR
BF
HA
EL