

# BRAKE SYSTEM

## SECTION **BR**

### CONTENTS

|   |    |                                     |    |
|---|----|-------------------------------------|----|
| <b>PRECAUTIONS AND PREPARATION</b> .....                        | 1  | Inspection.....                     | 17 |
| Supplemental Restraint System (SRS) "AIR BAG" (4WD models)..... | 1  | <b>VACUUM PUMP</b> .....            | 19 |
| Supplemental Restraint System (SRS) "AIR BAG" (2WD models)..... | 1  | Removal and Installation .....      | 19 |
| Precautions for Brake System .....                              | 1  | Inspection.....                     | 19 |
| Special Service Tools .....                                     | 2  | <b>FRONT DISC BRAKE</b> .....       | 21 |
| Commercial Service Tools.....                                   | 2  | Pad Replacement .....               | 21 |
| <b>CHECK AND ADJUSTMENT</b> .....                               | 3  | Removal.....                        | 22 |
| Checking Brake Fluid Level.....                                 | 3  | Disassembly.....                    | 23 |
| Checking Brake Line.....  | 3  | Inspection - Caliper.....           | 23 |
| Changing Brake Fluid .....                                      | 3  | Inspection - Rotor .....            | 23 |
| Bleeding Brake System .....                                     | 4  | Assembly.....                       | 24 |
| <b>BRAKE HYDRAULIC LINE</b> .....                               | 5  | Installation .....                  | 24 |
| <b>CONTROL VALVE</b> .....                                      | 7  | Brake Burnishing Procedure.....     | 24 |
| Load Sensing Valve.....   | 7  | <b>REAR DRUM BRAKE</b> .....        | 26 |
| <b>BRAKE PEDAL AND BRACKET</b> .....                            | 10 | Removal .....                       | 27 |
| Removal and Installation .....                                  | 10 | Inspection - Wheel Cylinder.....    | 28 |
| Inspection.....   | 11 | Wheel Cylinder Overhaul.....        | 28 |
| Adjustment .....  | 11 | Inspection - Drum .....             | 28 |
| <b>MASTER CYLINDER</b> .....                                    | 12 | Inspection - Lining.....            | 28 |
| Removal.....  | 12 | Installation .....                  | 28 |
| Disassembly.....  | 13 | <b>PARKING BRAKE CONTROL</b> .....  | 30 |
| Inspection.....   | 13 | Removal and Installation .....      | 31 |
| Assembly.....   | 13 | Inspection.....                     | 31 |
| Installation .....  | 14 | Adjustment .....                    | 31 |
| <b>BRAKE BOOSTER</b> .....                                      | 15 | <b>ANTI-LOCK BRAKE SYSTEM</b> ..... | 32 |
| On-vehicle Service.....   | 15 | Purpose.....                        | 32 |
| Removal .....   | 15 | Operation .....                     | 32 |
| Inspection.....   | 15 | ABS Hydraulic Circuit .....         | 32 |
| Installation .....  | 16 | System Components.....              | 33 |
| <b>VACUUM HOSE</b> .....  | 17 | System Description .....            | 33 |
| Removal and Installation .....                                  | 17 | Removal and Installation .....      | 35 |
|   |    | <b>TROUBLE DIAGNOSES</b> .....      | 38 |

|  |    |   |    |
|--|----|---|----|
| How to Perform Trouble Diagnoses for Quick and Accurate Repair .....               | 38 | Diagnostic Procedure 5 (G sensor) .....   | 70 |
| Preliminary Check.....   | 39 | Diagnostic Procedure 6 (Control unit) .....   | 71 |
| Component Parts and Harness Connector Location.....                                | 40 | <b>TROUBLE DIAGNOSES FOR SYMPTOMS</b> .....   | 72 |
| Schematic/2WD Models.....  | 41 | Diagnostic Procedure 7 (ABS works frequently.).....   | 72 |
| Wiring Diagram - ABS -/2WD LHD Models.....   | 42 | Diagnostic Procedure 8 (Unexpected pedal action).....   | 73 |
| Wiring Diagram - ABS -/2WD RHD Models .....  | 45 | Diagnostic Procedure 9 (Long stopping distance) .....   | 73 |
| Schematic/4WD Models.....  | 48 | Diagnostic Procedure 10 (ABS does not work.).....   | 74 |
| Wiring Diagram - ABS -/4WD Models .....  | 49 | Diagnostic Procedure 11 (Pedal vibration and noise).....  | 74 |
| Self-diagnosis.....  | 53 | Diagnostic Procedure 12 (Warning lamp does not come on when ignition switch is turned ON.)..... | 75 |
| CONSULT .....  | 56 | Diagnostic Procedure 13 (Warning lamp stays on when ignition switch is turned ON.).....         | 77 |
| CONSULT Inspection Procedure.....  | 57 | <b>SERVICE DATA AND SPECIFICATIONS (SDS)</b> ...  | 78 |
| Ground Circuit Check .....   | 62 | General Specifications .....  | 78 |
| <b>TROUBLE DIAGNOSES FOR SELF-DIAGNOSTIC ITEMS</b> .....                           | 63 | Inspection and Adjustment .....   | 80 |
| Diagnostic Procedure 1 (Wheel sensor or rotor).....                                | 63 |   |    |
| Diagnostic Procedure 2 (ABS actuator solenoid valve and solenoid valve relay)..... | 65 |   |    |
| Diagnostic Procedure 3 (Motor relay or motor)...                                   | 67 |   |    |
| Diagnostic Procedure 4 (Low voltage) .....   | 69 |   |    |

**When you read wiring diagrams:**

- Read GI section, “HOW TO READ WIRING DIAGRAMS”.
- See EL section, “POWER SUPPLY ROUTING” for power distribution circuit.

**When you perform trouble diagnoses, read GI section, “HOW TO FOLLOW FLOW CHART IN TROUBLE DIAGNOSES” and “HOW TO PERFORM EFFICIENT DIAGNOSIS FOR AN ELECTRICAL INCIDENT”.**

## PRECAUTIONS AND PREPARATION

### Supplemental Restraint System (SRS) “AIR BAG” (4WD models)

The Supplemental Restraint System “AIR BAG”, used along with a seat belt, helps to reduce the risk or severity of injury to the driver in a frontal collision. The Supplemental Restraint System consists of air bag module (located in the center of the steering wheel), a diagnosis sensor unit, warning lamp, wiring harness and spiral cable. Information necessary to service the system safely is included in the **RS section** of this Service Manual.

#### WARNING:

- To avoid rendering the SRS inoperative, which could increase the risk of personal injury or death in the event of a collision which would result in air bag inflation, all maintenance must be performed by an authorized NISSAN dealer.
- Improper maintenance, including incorrect removal and installation of the SRS, can lead to personal injury caused by unintentional activation of the system.
- Do not use electrical test equipment on any circuit related to the SRS unless instructed to in this Service Manual. SRS wiring harnesses are covered with yellow insulation either just before the harness connectors or for the complete harness, for easy identification.

### Supplemental Restraint System (SRS) “AIR BAG” (2WD models)

The Supplemental Restraint System “AIR BAG”, used along with a seat belt, helps to reduce the risk or severity of injury to the driver in a frontal collision. The Supplemental Restraint System consists of an air bag module (located in the center of the steering wheel), a diagnosis sensor unit, warning lamp and spiral cable. Information necessary to service the system safely is included in the **RS section** of this Service Manual.

#### WARNING:

- To avoid rendering the SRS inoperative, which could increase the risk of personal injury or death in the event of a collision which would result in air bag inflation, all maintenance must be performed by an authorized NISSAN dealer.
- Improper maintenance, including incorrect removal and installation of the SRS, can lead to personal injury caused by unintentional activation of the system.
- Do not use electrical test equipment on any circuit related to the SRS.

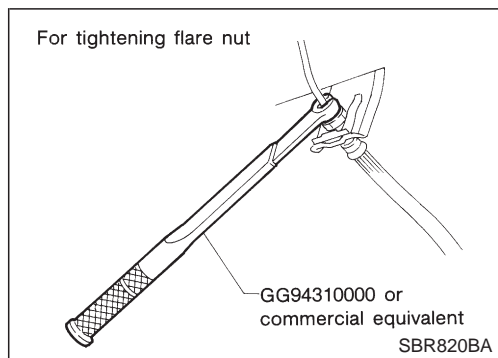

### Precautions for Brake System

- Use brake fluid DOT 3 or DOT 4\*1.
- Never reuse drained brake fluid.
- Be careful not to splash brake fluid on painted areas; it may cause paint damage. If brake fluid is splashed on painted areas, wash it away with water immediately.
- To clean master cylinder parts, disc brake caliper parts or wheel cylinder parts, use clean brake fluid.
- Never use mineral oils such as gasoline or kerosene. They will ruin rubber parts of the hydraulic system.
- Use flare nut wrench when removing and installing brake tubes.
- Always torque brake lines when installing.



#### WARNING:

- Clean brakes with a vacuum dust collector to minimize the hazard of airborne materials.

\*1: Refer to MA section (“Fluids and Lubricants”, “RECOMMENDED FLUIDS AND LUBRICANTS”).

# PRECAUTIONS AND PREPARATION

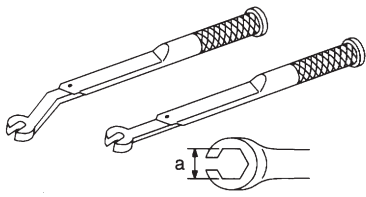
## Special Service Tools

| Tool number<br>Tool name              | Description   |   |
|---------------------------------------|---|---|
| GG94310000<br>Flare nut torque wrench |  | Removing and installing each brake piping<br><br><b>a: 10 mm (0.39 in)</b><br> : 16.2 N·m (1.65 kg·m, 11.9 ft·lb) |

## Commercial Service Tools

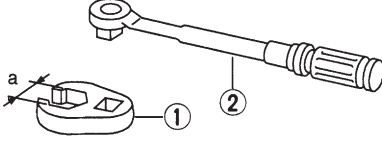
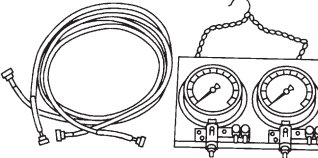
| Tool name                               | Description  |  |
|---|--|--|
| ① Flare nut crowfoot<br>② Torque wrench |   | Removing and installing each brake piping<br><br><b>a: 10 mm (0.39 in)</b> |
| Brake fluid pressure gauge              |  | Measuring brake fluid pressure   |

## CHECK AND ADJUSTMENT

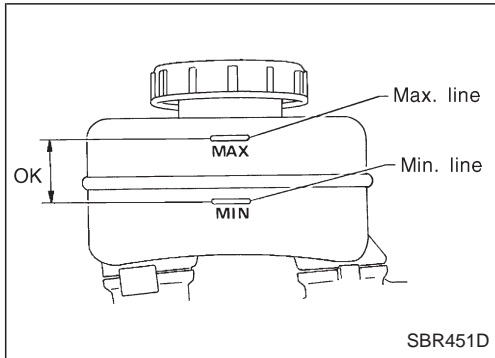

### Checking Brake Fluid Level

- Check fluid level in reservoir tank. It should be between Max and Min lines on reservoir tank.
- If fluid level is extremely low, check brake system for leaks.
- If the brake warning lamp comes on, check brake fluid level switch and parking brake switch.

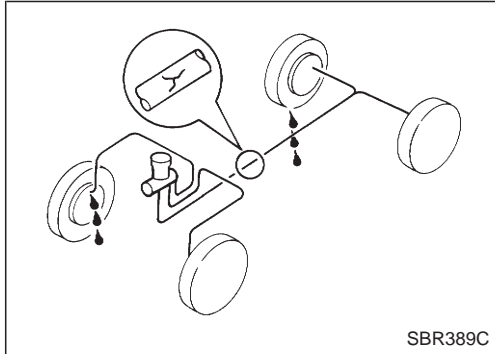

### Checking Brake Line

#### CAUTION:

**If leakage occurs around joints, retighten or, if necessary, replace damaged parts.**

1. Check brake lines (tubes and hoses) for cracks, deterioration or other damage. Replace any damaged parts.
2. Check for oil leakage by fully depressing brake pedal while engine is running.

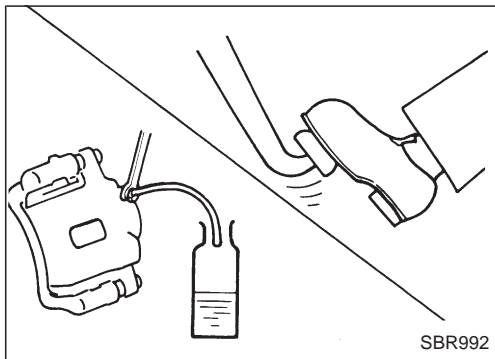

### Changing Brake Fluid

#### CAUTION:

- Refill with new brake fluid DOT 3 or DOT 4\*1.
- Always keep fluid level higher than minimum line on reservoir tank.
- Never reuse drained brake fluid.
- Be careful not to splash brake fluid on painted areas; it may cause paint damage. If brake fluid is splashed on painted areas, wash it away with water immediately.

1. Clean inside of reservoir tank, and refill with new brake fluid.
2. Connect a vinyl tube to each air bleeder valve.
3. Drain brake fluid from each air bleeder valve by depressing brake pedal.
4. Refill until brake fluid comes out of each air bleeder valve. Use same procedure as in bleeding hydraulic system to refill brake fluid. Refer to "Bleeding Brake System", BR-4.

\*1: Refer to MA section ("Fluids and Lubricants", "RECOMMENDED FLUIDS AND LUBRICANTS").

## CHECK AND ADJUSTMENT

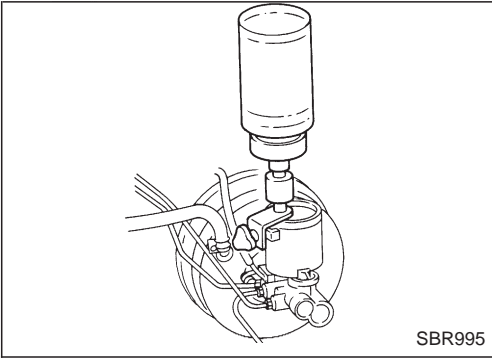

### Bleeding Brake System

#### CAUTION:

- Carefully monitor brake fluid level at master cylinder during bleeding operation.
- If master cylinder is suspected to have air inside, bleed air from master cylinder first. Refer to "Installation", "MASTER CYLINDER", BR-14.
- Fill reservoir with new brake fluid DOT 3 or DOT 4\*1. Make sure it is full at all times while bleeding air out of system.
- Place a container under master cylinder to avoid spillage of brake fluid.
- For models with ABS, turn ignition switch OFF and disconnect ABS actuator connector or battery cable.
- Bleed air in the following order.
  - a. LSV air bleeder
  - b. Left rear brake
  - c. Right rear brake
  - d. Left front brake
  - e. Right front brake

\*1: Refer to MA section ("Fluids and Lubricants", "RECOMMENDED FLUIDS AND LUBRICANTS").

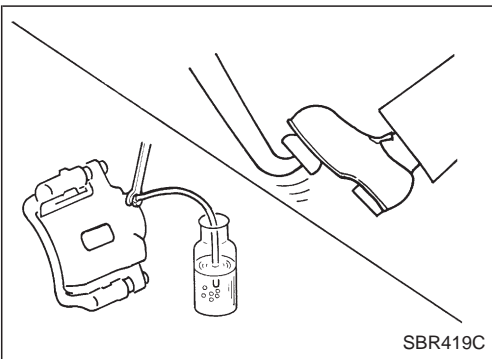

1. Connect a transparent vinyl tube to air bleeder valve.
2. Fully depress brake pedal several times.
3. With brake pedal depressed, open air bleeder valve to release air.
4. Close air bleeder valve.
5. Release brake pedal slowly.
6. Repeat steps 2 through 5 until clear brake fluid comes out of air bleeder valve.
7. Tighten air bleeder to the specified torque.  
🔧: 7 - 9 N·m (0.7 - 0.9 kg·m, 61 - 78 in·lb)

# BRAKE HYDRAULIC LINE

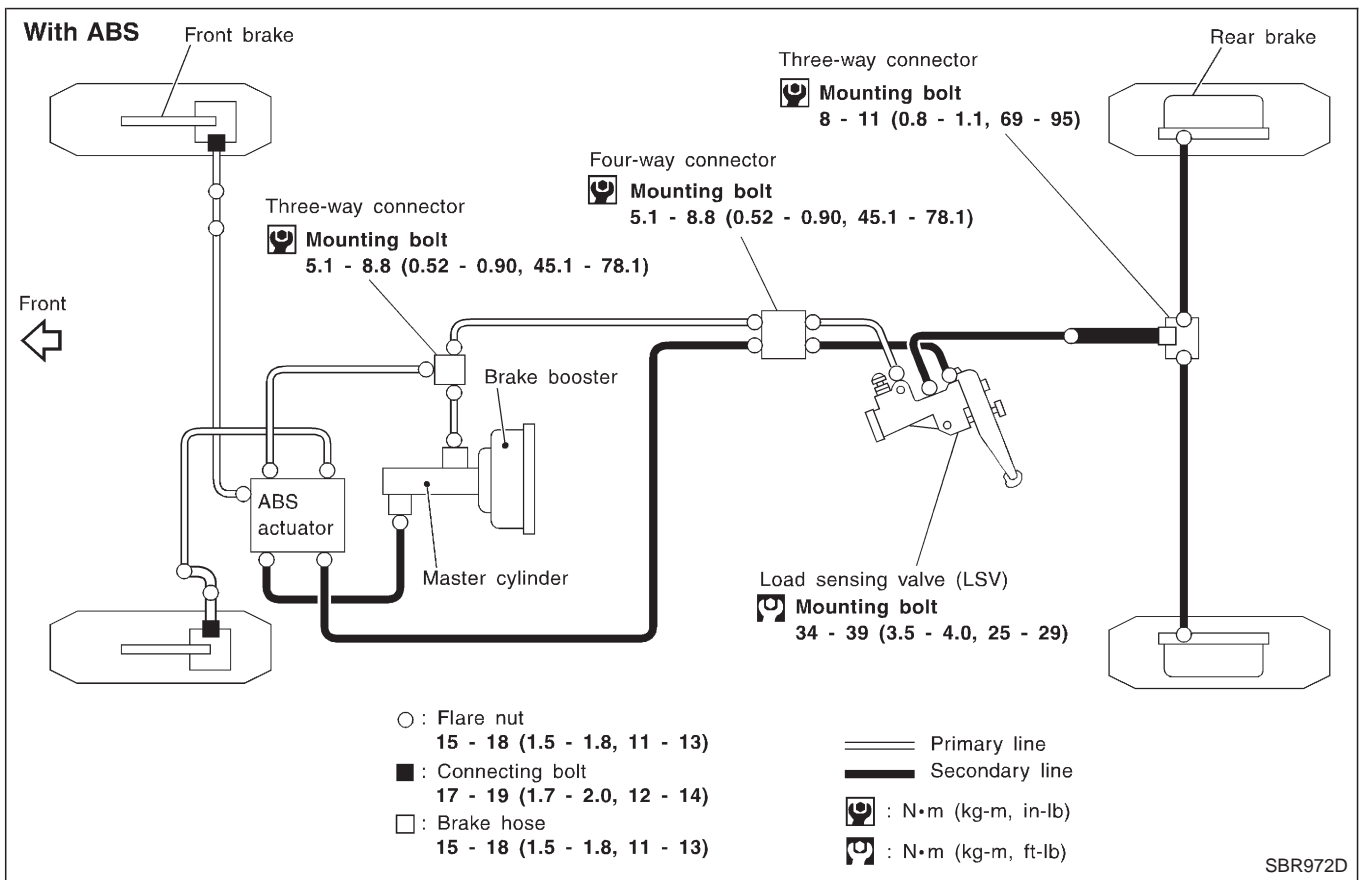
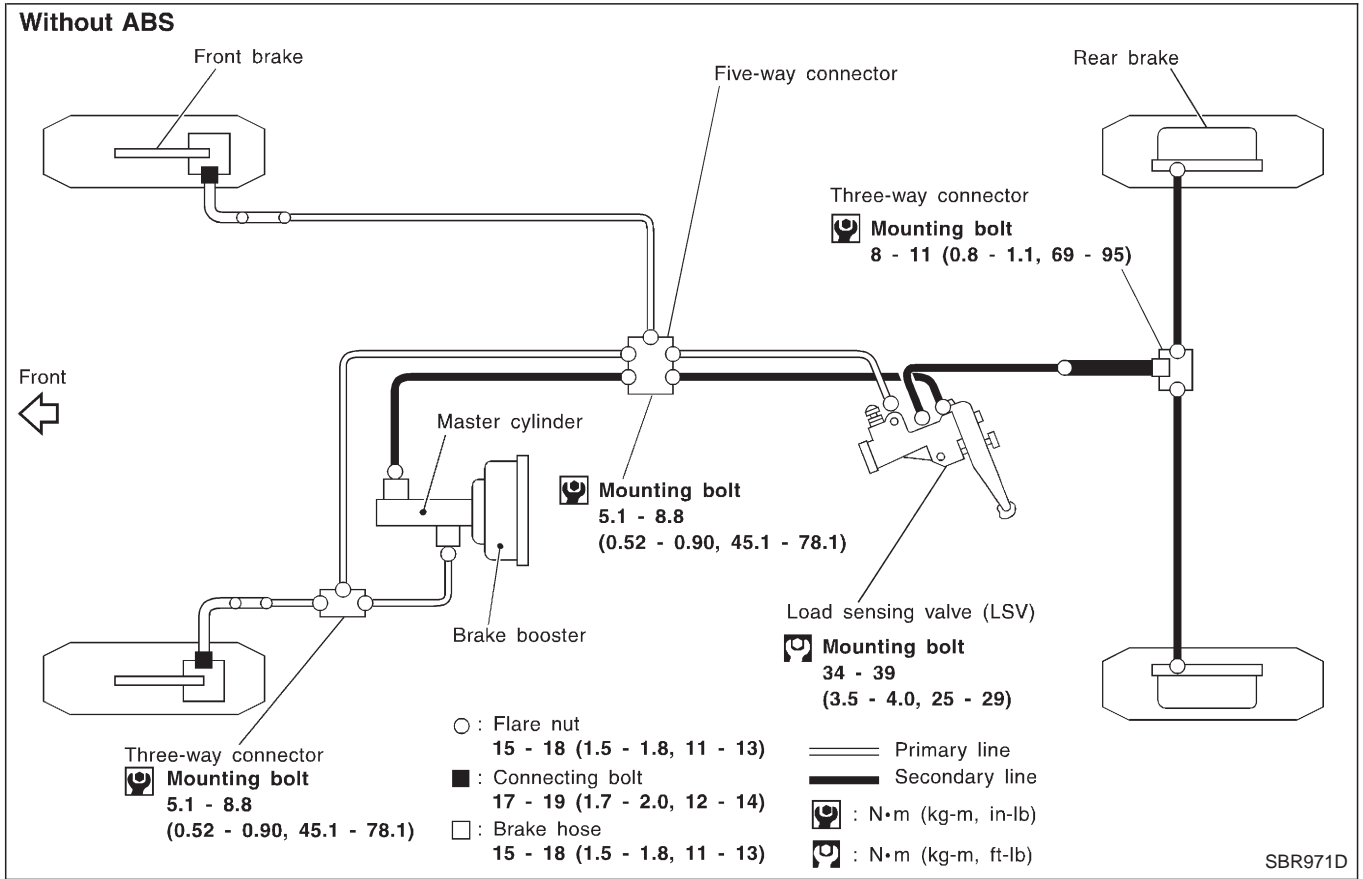

## BRAKE HYDRAULIC LINE

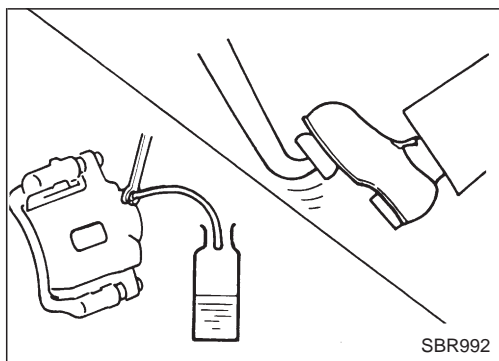

### REMOVAL

#### CAUTION:

- Be careful not to splash brake fluid on painted areas; it may cause paint damage. If brake fluid is splashed on painted areas, wash it away with water immediately.
  - All hoses must be free from excessive bending, twisting and pulling.
1. Connect vinyl tube to air bleeder valve.
  2. Drain brake fluid from each air bleeder valve by depressing brake pedal.
  3. Remove flare nut connecting brake tube and hose, then withdraw lock spring.
  4. Cover openings to prevent entrance of dirt whenever disconnecting brake line.

### INSPECTION

Check brake lines (tubes and hoses) for cracks, deterioration or other damage. Replace any damaged parts.

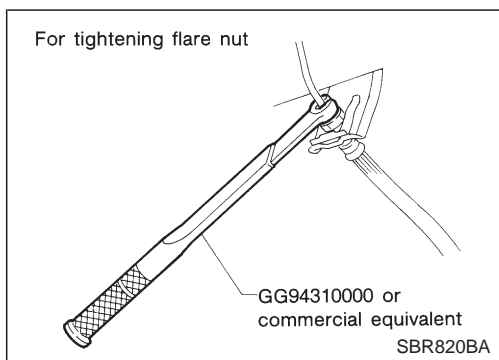

### INSTALLATION

#### CAUTION:

- Refill with new brake fluid DOT 3 or DOT 4\*1.
  - Never reuse drained brake fluid.
1. Tighten all flare nuts and connecting bolts.  
**Flare nut:**  
⊗: 15 - 18 N·m (1.5 - 1.8 kg·m, 11 - 13 ft·lb)  
**Connecting bolt:**  
⊗: 17 - 19 N·m (1.7 - 2.0 kg·m, 12 - 14 ft·lb)
  2. Refill until new brake fluid comes out of each air bleeder valve.
  3. Bleed air. Refer to "Bleeding Brake System", BR-4.
- \*1: Refer to MA section ("Fluids and Lubricants", "RECOMMENDED FLUIDS AND LUBRICANTS").



# CONTROL VALVE

## Load Sensing Valve

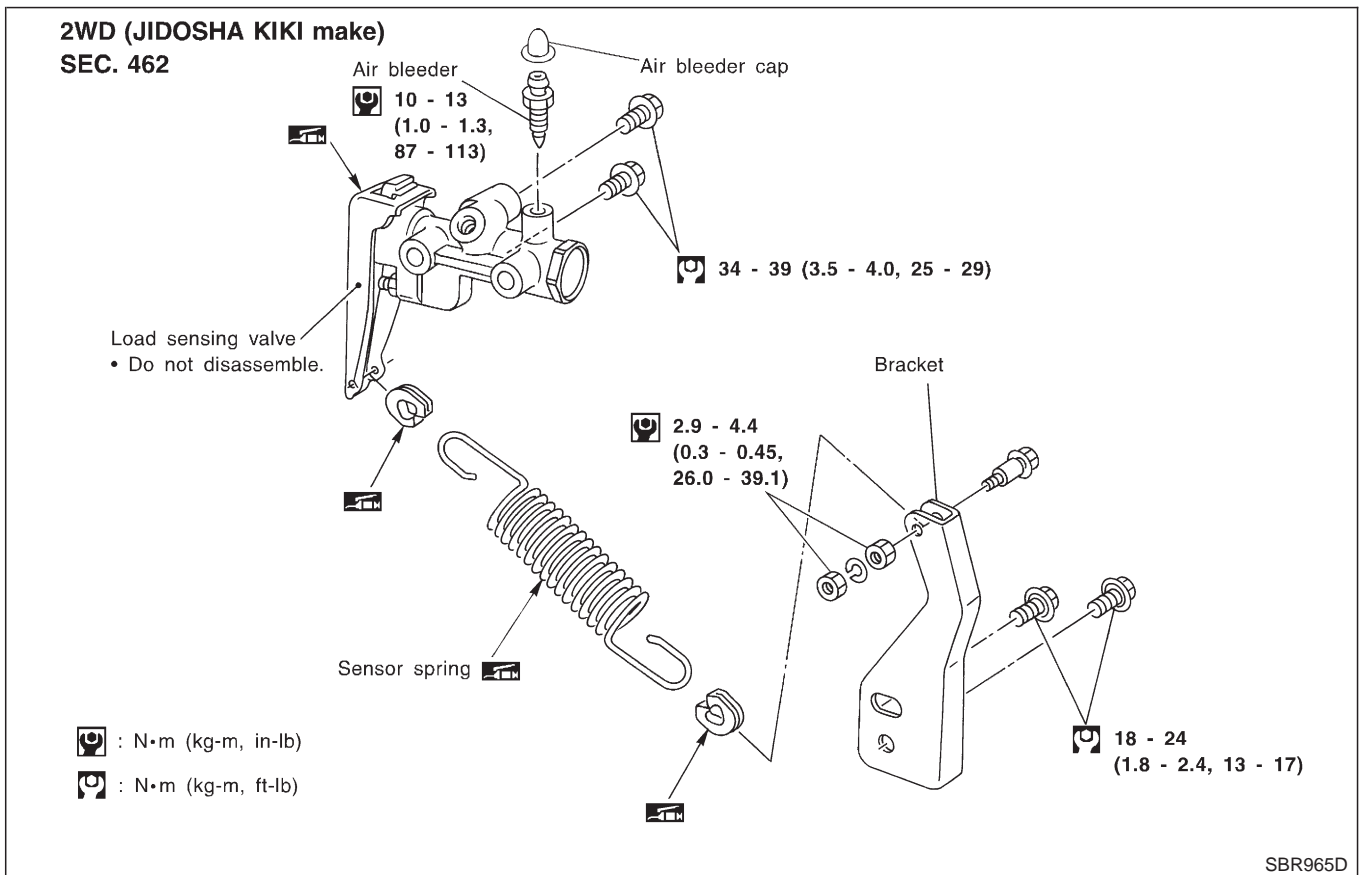
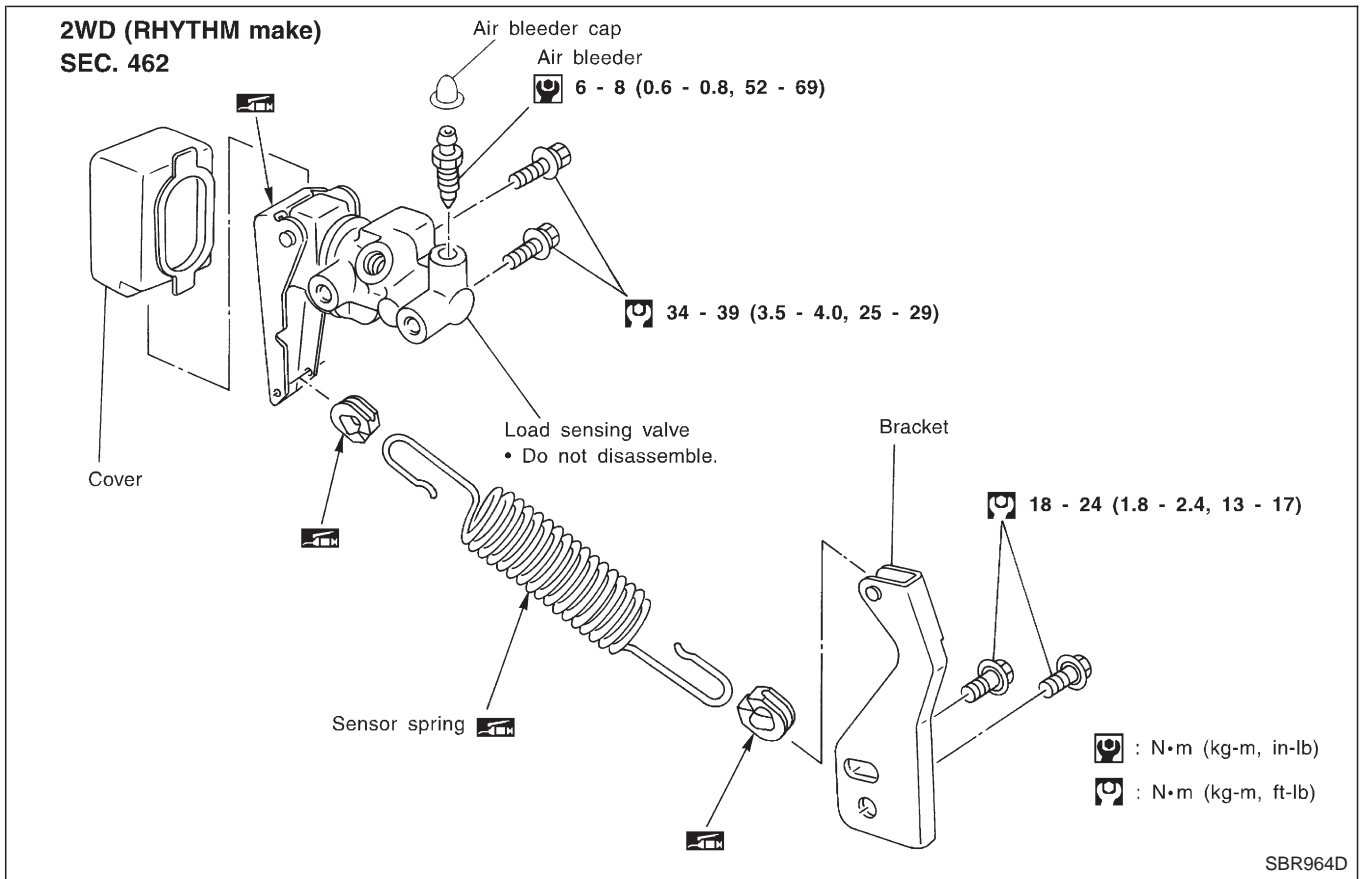



# CONTROL VALVE

## Load Sensing Valve (Cont'd)

### INSPECTION

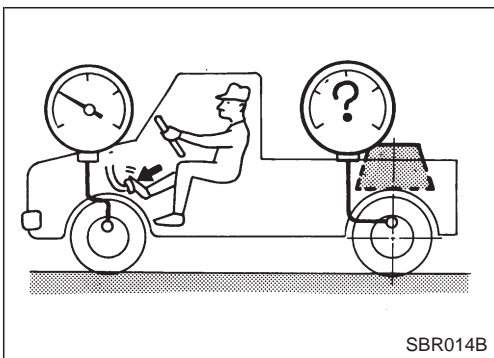
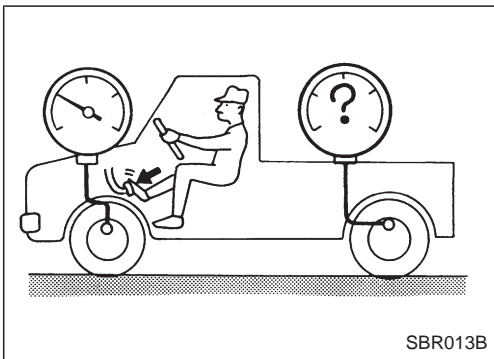
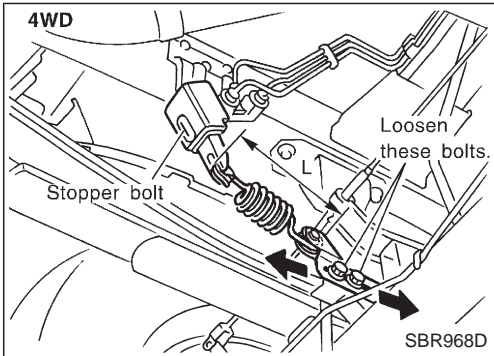
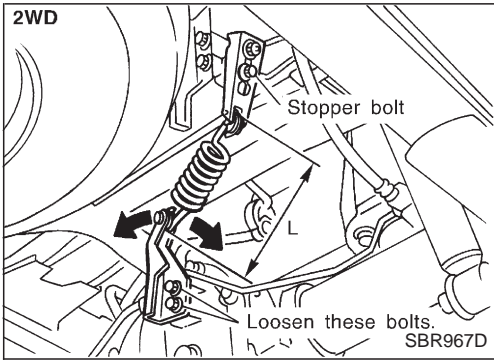

1. Ensure vehicle is unladen condition\*.
  - \* Fuel, radiator coolant and engine oil full. Spare tire, jack, hand tools and mats in designated positions.
2. Have a driver sit in the driver's seat and one person sit on the rear of the vehicle. Then have the person on the rear of the vehicle slowly get off. This is necessary to stabilize suspension deflection.
3. Adjust length "L" as follows:
  - a. Loosen stopper bolt locknut (2WD JIDOSHA KIKI make).
  - b. Pull lever against stopper bolt and adjust by turning stopper bolt.
  - c. Tighten stopper bolt locknut (2WD JIDOSHA KIKI make).

#### Length "L":

#### 2WD models

Approx. 187.3 mm (7.37 in)

#### 4WD models

Approx. 158.1 mm (6.22 in)

4. Install pressure gauge to front and rear brake air bleeder.
5. Bleed air from the Tool.
6. Raise front brake pressure to 4,904 kPa (49.0 bar, 50 kg/cm<sup>2</sup>, 711 psi) and 9,807 kPa (98.1 bar, 100 kg/cm<sup>2</sup>, 1,422 psi) and check rear brake pressure.

#### Rear brake pressure:

Refer to table below.

Unit: kPa (bar, kg/cm<sup>2</sup>, psi)

| Front brake pressure        | Rear brake pressure                                |  |  |  |
|-----------------------------|--|--|--|--|
|                             | 2WD  |  | 4WD  |  |
|                             | Unladen condition<br>L = 187.3 mm<br>(7.37 in)     | Loaded condition<br>L = 204.0 mm<br>(8.03 in)      | Unladen condition<br>L = 158.1 mm<br>(6.22 in)     | Loaded condition<br>L = 184.0 mm<br>(7.24 in)      |
| 4,904<br>(49.0, 50, 711)    | 1,667 - 2,648<br>(16.7 - 26.5, 17 - 27, 242 - 384) | 3,334 - 4,315<br>(33.3 - 43.2, 34 - 44, 483 - 626) | 1,863 - 2,844<br>(18.6 - 28.4, 19 - 29, 270 - 412) | 3,334 - 4,315<br>(33.3 - 43.2, 34 - 44, 483 - 626) |
| 9,807<br>(98.1, 100, 1,422) | 2,844 - 3,825<br>(28.4 - 38.2, 29 - 39, 412 - 555) | 3,629 - 5,590<br>(36.3 - 55.9, 37 - 57, 526 - 811) | 2,059 - 4,021<br>(20.6 - 40.2, 21 - 41, 299 - 583) | 3,629 - 5,590<br>(36.3 - 55.9, 37 - 57, 526 - 811) |

# BRAKE PEDAL AND BRACKET

## Removal and Installation

LHD

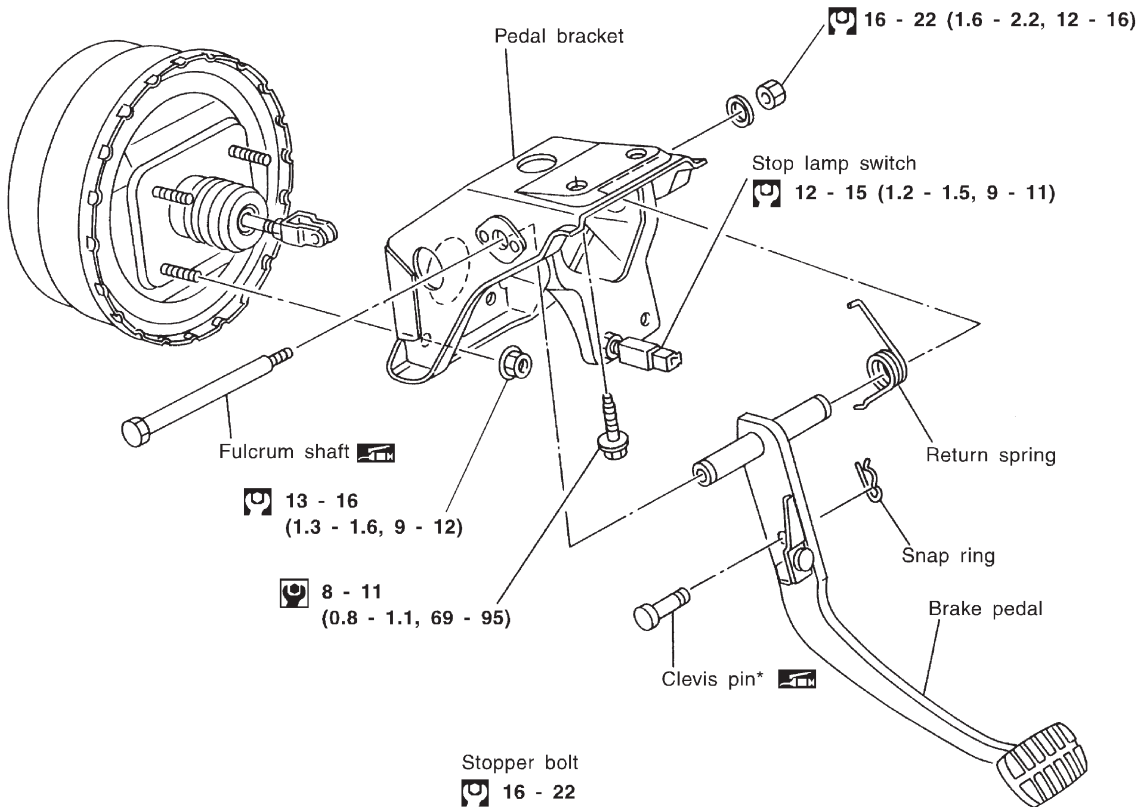

RHD

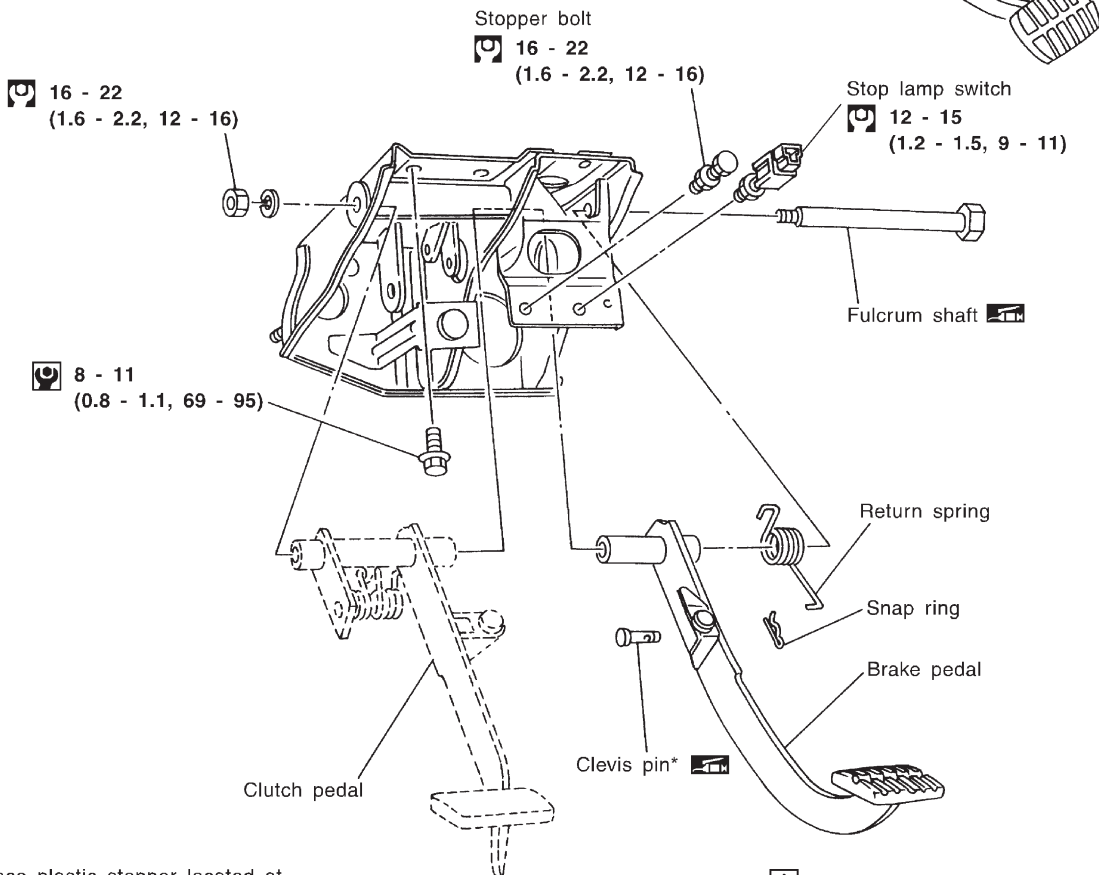

\* Replace plastic stopper located at the end of clevis pin, if deformed or damaged.

: N•m (kg-m, in-lb)

: N•m (kg-m, ft-lb)

# BRAKE PEDAL AND BRACKET

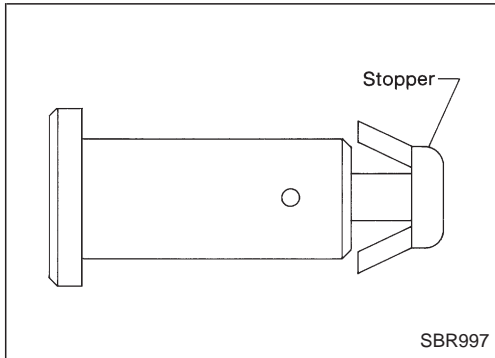

## Inspection

Check brake pedal for following items:

- Brake pedal bend
- Clevis pin deformation
- Crack of any welded portion
- Crack or deformation of clevis pin stopper

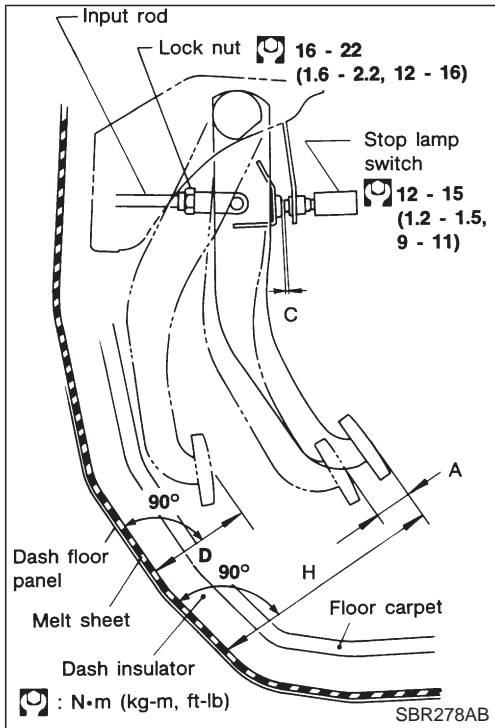

## Adjustment

Check brake pedal free height from melt sheet.

### H: Free height

Refer to SDS, BR-80.

### D: Depressed height

Refer to SDS, BR-80.

Under force of 490 N (50 kg, 110 lb)  
with engine running

### C: Clearance between pedal stopper and threaded end of stop lamp switch

0.3 - 1.0 mm (0.012 - 0.039 in)

### A: Pedal free play at clevis

1 - 3 mm (0.04 - 0.12 in)

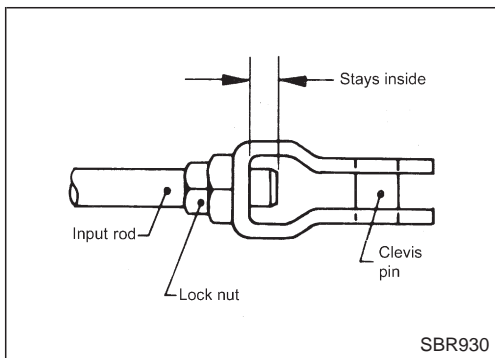

If necessary, adjust brake pedal free height.

1. Loosen lock nut and adjust pedal free height by turning brake booster input rod. Then tighten lock nut.

- **Make sure that the tip of input rod stays inside.**

2. Loosen lock nut and adjust clearance "C" with stop lamp switch respectively. Then tighten lock nuts.

3. Check pedal free play.

- **Make sure that stop lamp is off when pedal is released.**

4. Check brake pedal's depressed height while engine is running. If lower than specification, check for leaks, air in system, or damage to components (master cylinder, wheel cylinder, etc.). Then make necessary repairs.

# MASTER CYLINDER

SEC. 460

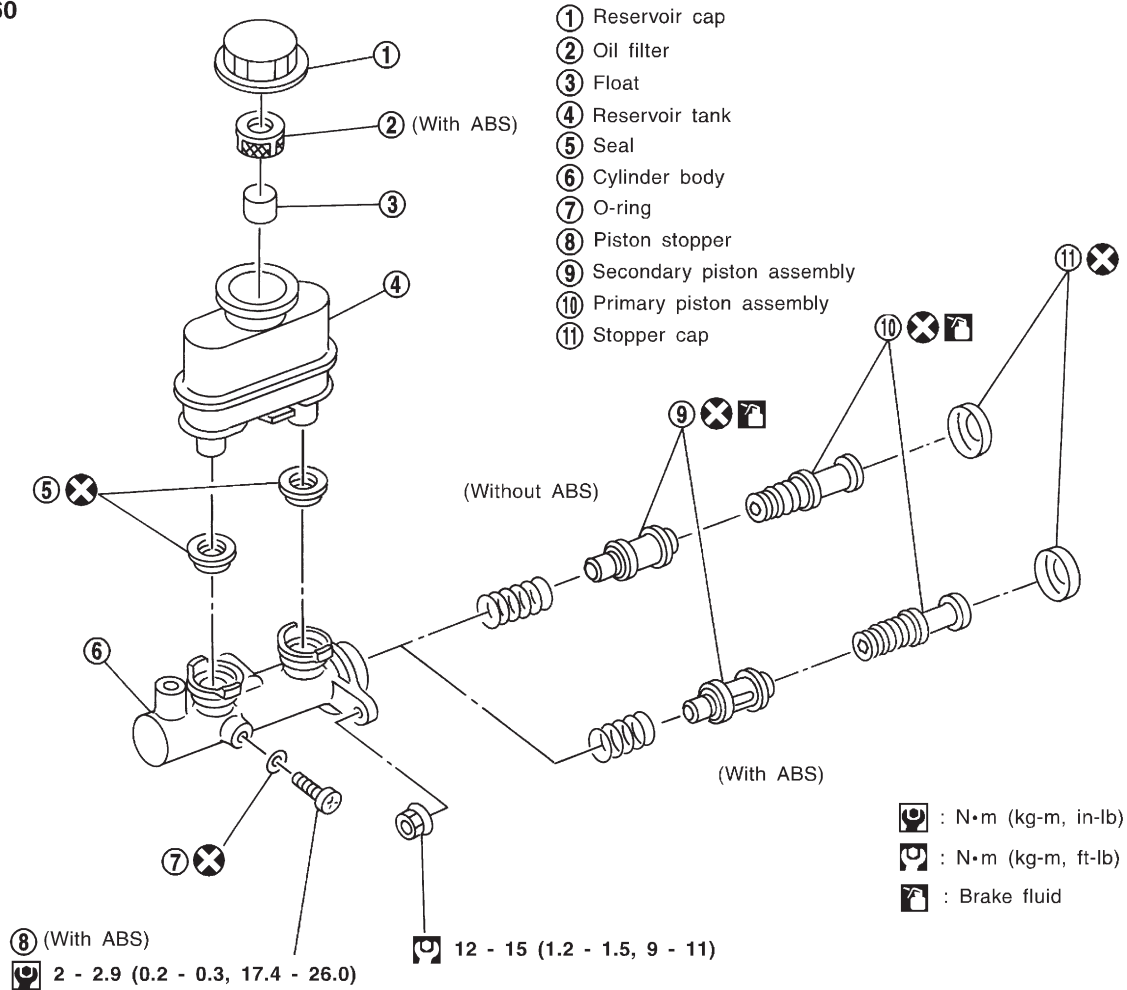

SBR970D

## Removal

### CAUTION:

- Be careful not to splash brake fluid on painted areas; it may cause paint damage. If brake fluid is splashed on painted areas, wash it away with water immediately.
- In the case of brake fluid leakage from the master cylinder, disassemble the cylinder. Then check piston cups for deformation or scratches and replace necessary parts.

1. Connect a vinyl tube to air bleeder valve.
2. Drain brake fluid from each air bleeder valve, depressing brake pedal to empty fluid from master cylinder.
3. Remove brake pipe flare nuts.
4. Remove master cylinder mounting nuts.

# MASTER CYLINDER

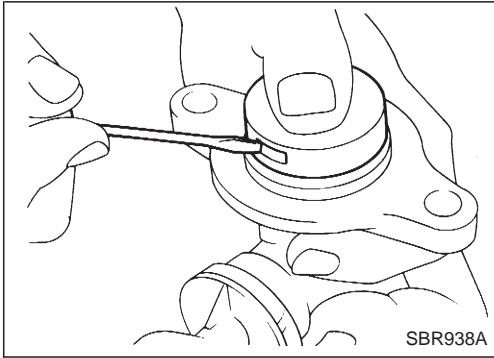

## Disassembly

1. Bend claws of stopper cap outward.

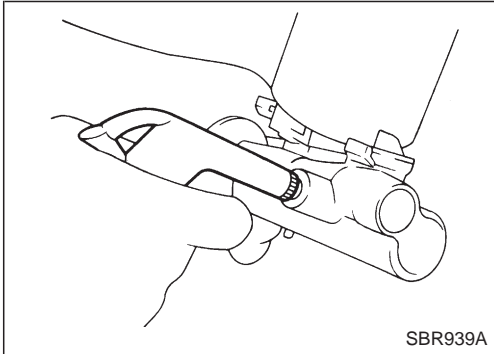

2. Remove piston assemblies.
  - If it is difficult to remove secondary piston assembly, gradually apply compressed air through fluid outlet.
3. Draw out reservoir tank.

## Inspection

Check master cylinder inner wall for pin holes or scratches. Replace if damaged.

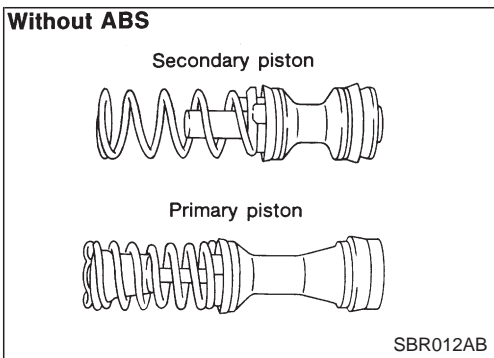

## Assembly

1. Insert secondary piston assembly. Then insert primary piston assembly.
  - Pay attention to direction of piston cups in figure at left. Also, insert pistons squarely to avoid scratches on cylinder bore.

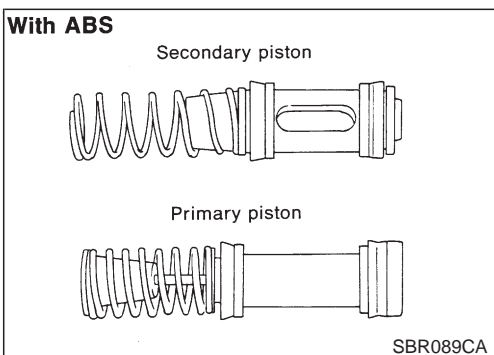

## MASTER CYLINDER

### Assembly (Cont'd)

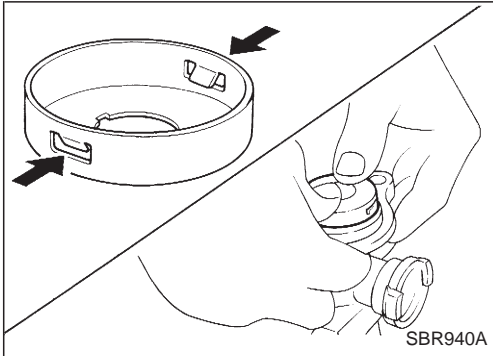

2. Install stopper cap.
- **Before installing stopper cap, ensure that claws are bent inward.**
3. Push reservoir tank seals into cylinder body.
4. Push reservoir tank into cylinder body.

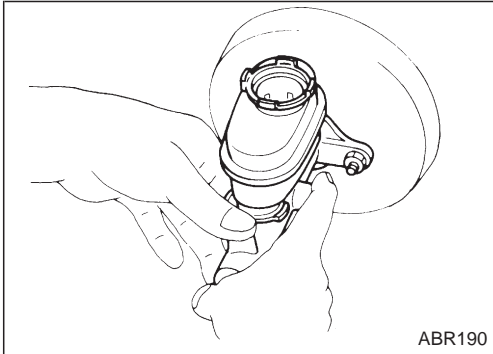

### Installation

#### CAUTION:

- **Refill with new brake fluid DOT 3 or DOT 4\*1.**
  - **Never reuse drained brake fluid.**
1. Place master cylinder onto brake booster and secure mounting nuts lightly.
  2. Tighten mounting nuts.  
⚙: **12 - 15 N-m (1.2 - 1.5 kg-m, 9 - 11 ft-lb)**
  3. Fill up reservoir tank with new brake fluid.
  4. Plug all ports on master cylinder with fingers to prevent air suction while releasing brake pedal.
  5. Have driver depress brake pedal slowly several times until no air comes out of master cylinder.
  6. Fit brake lines to master cylinder.
  7. Tighten flare nuts.  
⚙: **15 - 18 N-m (1.5 - 1.8 kg-m, 11 - 13 ft-lb)**
  8. Bleed air from brake system. Refer to "Bleeding Brake System", BR-4.
- \*1: Refer to MA section ("Fluids and Lubricants", "RECOMMENDED FLUIDS AND LUBRICANTS").



# BRAKE BOOSTER

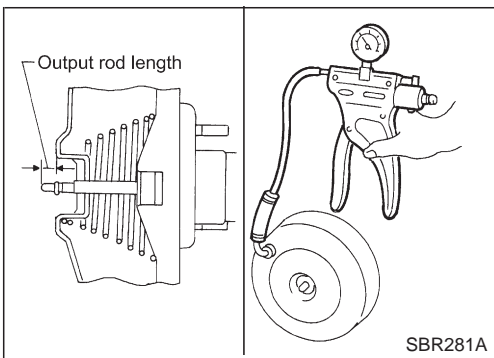
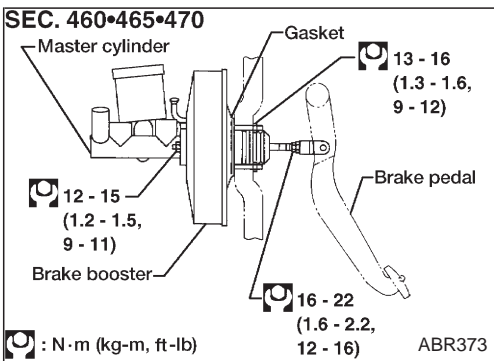
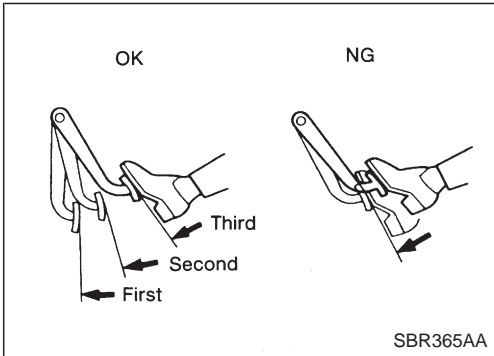
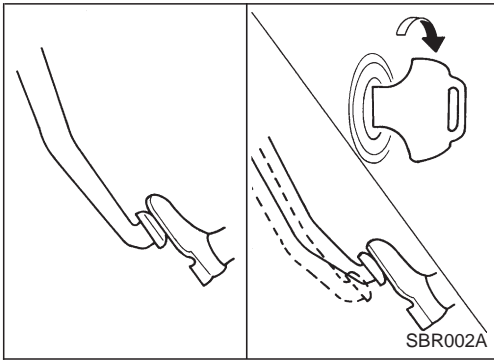

## On-vehicle Service

### OPERATING CHECK

- Depress brake pedal several times with engine off. After exhausting vacuum, make sure there is no change in pedal stroke.
- Depress brake pedal, then start engine. If pedal goes down slightly, operation is normal.

### AIRTIGHT CHECK

- Start engine, and stop it after one or two minutes. Depress brake pedal several times slowly. Booster is airtight if pedal stroke is less each time.
- Depress brake pedal while engine is running, and stop engine with pedal depressed. The pedal stroke should not change after holding pedal down for **30 seconds**.

## Removal

### CAUTION:

- Be careful not to splash brake fluid on painted areas; it may cause paint damage. If brake fluid is splashed on painted areas, wash it away with water immediately.
- Be careful not to deform or bend brake pipes during removal of booster.

## Inspection

### OUTPUT ROD LENGTH CHECK

1. Apply vacuum of  $-66.7$  kPa ( $-667$  mbar,  $-500$  mmHg,  $-19.69$  inHg) to brake booster with a hand vacuum pump.
2. Check output rod length.

#### Specified length:

**10.275 - 10.525 mm (0.4045 - 0.4144 in)**

# BRAKE BOOSTER

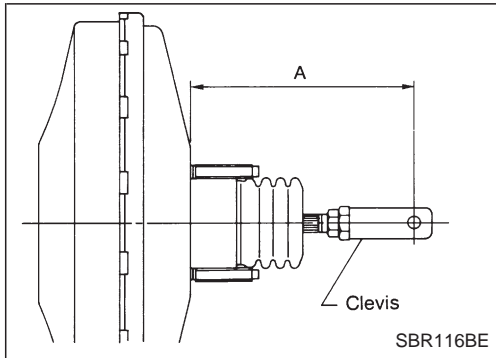

## Installation

### CAUTION:

- Be careful not to deform or bend brake pipes during installation of booster.
- Replace clevis pin if damaged.
- Refill with new brake fluid DOT 3 or DOT 4\*1.
- Never reuse drained brake fluid.
- Take care not to damage brake booster mounting bolt thread when installing. Due to the narrow angle of installation, the threads can be damaged by the dash panel.

### A: S230, M215T

LHD 165 mm (6.50 in)

RHD 185 mm (7.28 in)

### M195T

LHD 160 mm (6.30 in)

RHD 180 mm (7.09 in)

1. Before fitting booster, temporarily adjust clevis to dimension shown.
  2. Fit booster, then secure mounting nuts (brake pedal bracket to brake booster) lightly.
  3. Connect brake pedal and booster input rod with clevis pin.
  4. Secure mounting nuts.  
⚙️: 13 - 16 N·m (1.3 - 1.6 kg·m, 9 - 12 ft·lb)
  5. Install master cylinder. Refer to "Installation", "MASTER CYLINDER", BR-14.
  6. Adjust brake pedal height and free play. Refer to BR-11.
  7. Secure lock nut for clevis.  
⚙️: 16 - 22 N·m (1.6 - 2.2 kg·m, 12 - 16 ft·lb)
  8. Bleed air. Refer to "Bleeding Brake System", BR-4.
- \*1: Refer to MA section ("Fluids and Lubricants", "RECOMMENDED FLUIDS AND LUBRICANTS").

# VACUUM HOSE

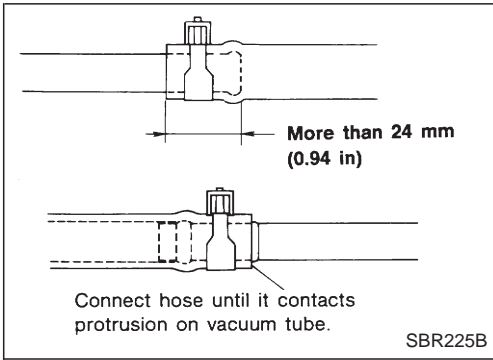

## Removal and Installation

### CAUTION:

When installing vacuum hoses, pay attention to the following points.

- Do not apply any oil or lubricants to vacuum hose and check valve.
- Insert vacuum tube into vacuum hose as shown.

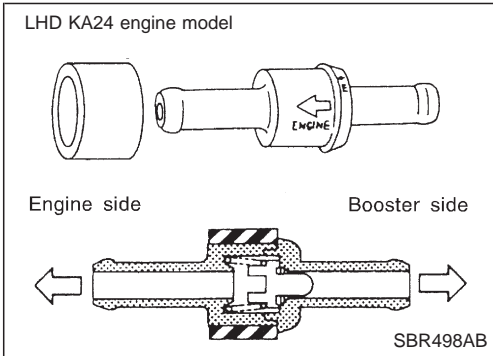

- Install check valve, paying attention to its direction.

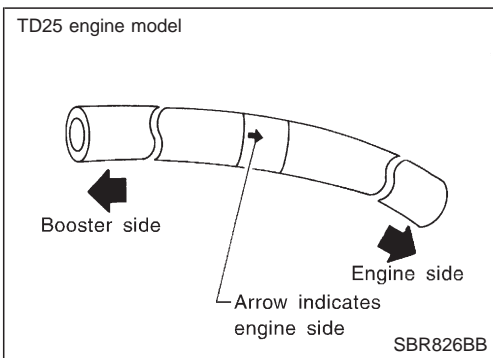

## Inspection

### HOSES AND CONNECTORS

Check vacuum lines, connections and check valve for airtightness, improper attachment chafing and deterioration.

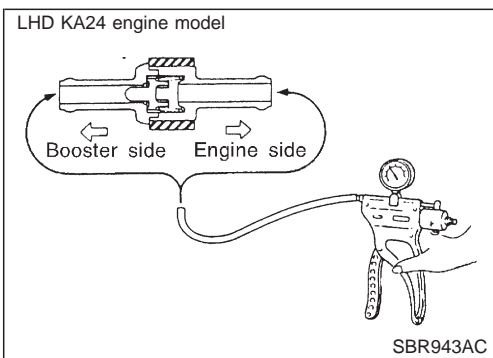

### CHECK VALVE

Check vacuum with a vacuum pump.

|                         |                          |
|-------------------------|--------------------------|
| Connect to booster side | Vacuum should exist.     |
| Connect to engine side  | Vacuum should not exist. |

# VACUUM HOSE Inspection (Cont'd)

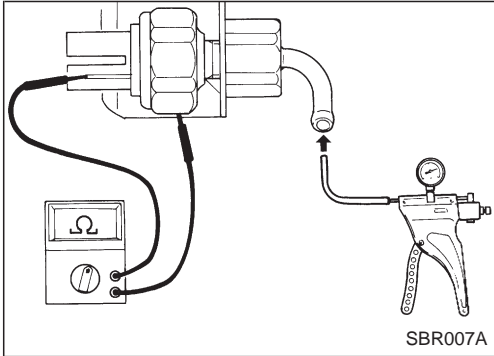
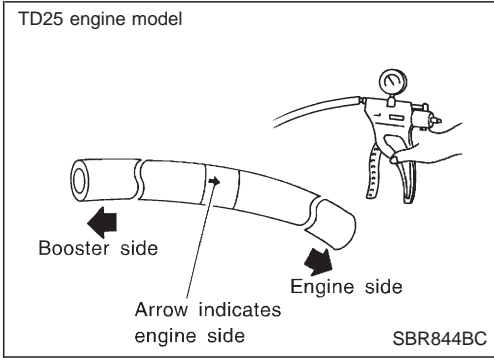

## VACUUM WARNING SWITCH\*

Test continuity through vacuum warning switch with an ohmmeter and vacuum pump.

|        |   |    |
|--------|---|----|
| Vacuum | Less than 26.7 kPa<br>(267 mbar, 200 mmHg, 7.87 inHg) | 0Ω |
|        | 33.3 kPa<br>(333 mbar, 250 mmHg, 9.84 inHg) or more   | ∞Ω |

\*Diesel engine models

# VACUUM PUMP

## Removal and Installation

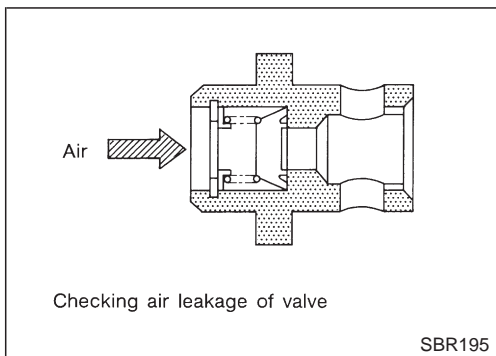
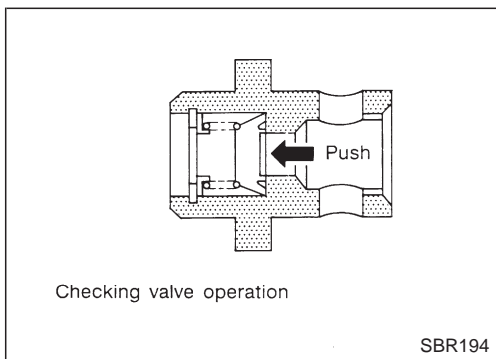
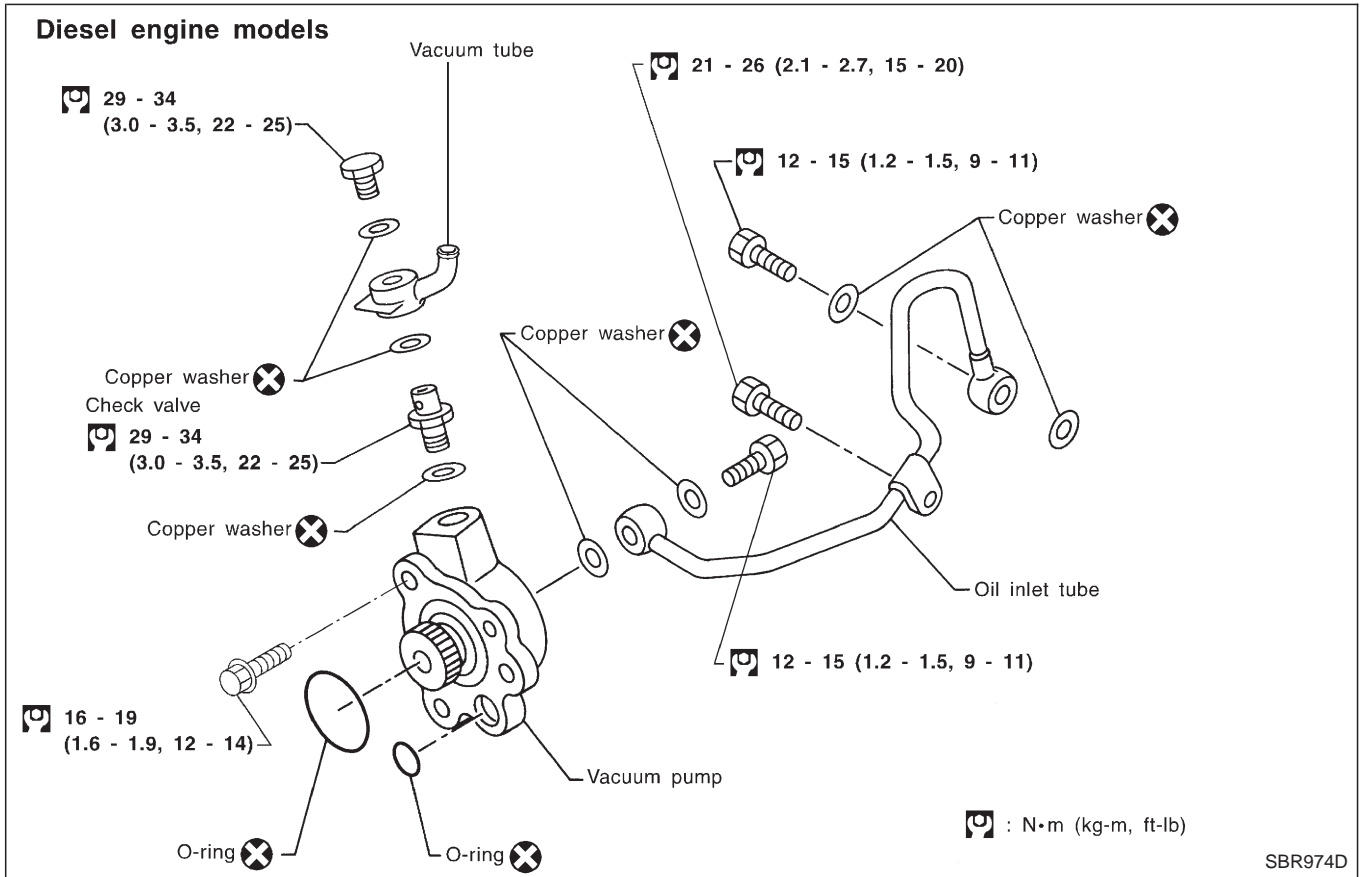

## Inspection

### CHECK VALVE

1. Check valve operation. Check that valve operates smoothly when slightly pushed. Replace if necessary.
2. Check for air leakage with 98 to 490 kPa (1.0 to 4.9 bar, 1 to 5 kg/cm<sup>2</sup>, 14 to 71 psi) of air pressure. Replace if necessary.

## VACUUM PUMP

### Inspection (Cont'd)

#### VACUUM

1. Install vacuum gauge.
2. Run engine at 1,000 rpm or more.
3. Check vacuum.

#### Specified vacuum:

**86.6 kPa (866 mbar, 650 mmHg, 25.59 inHg) or more**

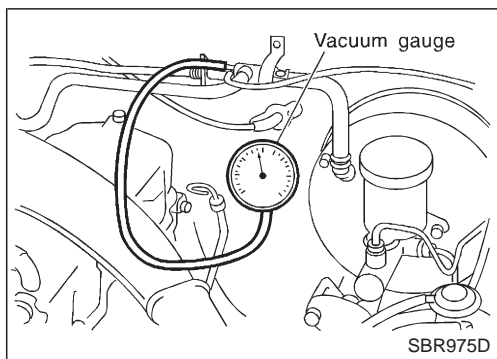

# FRONT DISC BRAKE

## Pad Replacement

### WARNING:

Clean brake pads with a vacuum dust collector to minimize the hazard of airborne materials.

### CAUTION:

- When cylinder body is open, do not depress brake pedal or caliper piston will pop out.
- Be careful not to damage piston boot or get oil on rotor. Always replace shims when replacing pads.
- If shims are rusted or show peeling of the rubber coat, replace them with new shims.
- It is not necessary to remove connecting bolt except for disassembly or replacement of caliper assembly. In this case, suspend cylinder body with wire so as not to stretch brake hose.

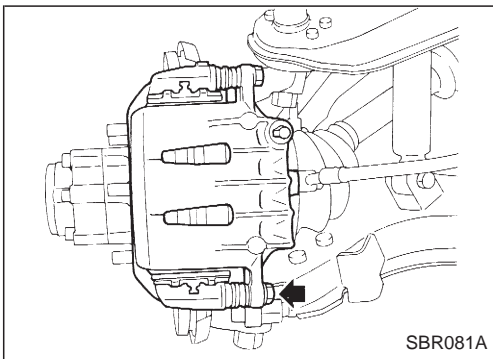

1. Remove master cylinder reservoir cap.
2. Remove lower pin bolt.

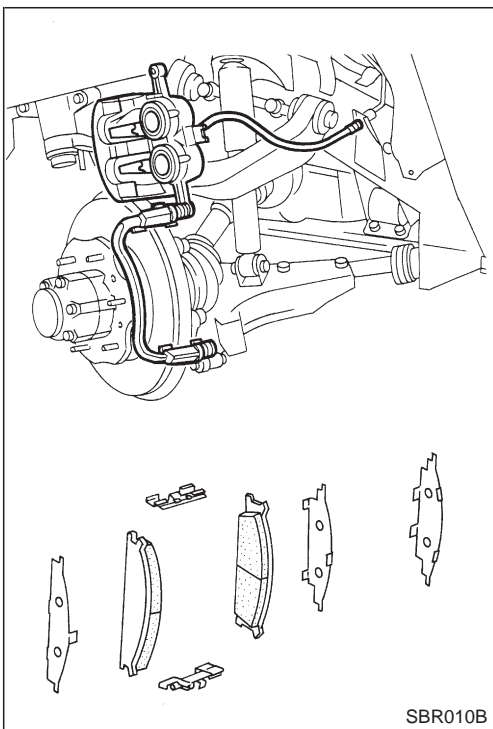

3. Open cylinder body upward. Then remove pad retainers, return spring and inner and outer shims.  
**Standard pad thickness:**  
CL28VD model  
10 mm (0.39 in)  
**Pad wear limit:**  
2.0 mm (0.079 in)
- Carefully monitor brake fluid level because brake fluid will return to reservoir when pushing back piston.

# FRONT DISC BRAKE

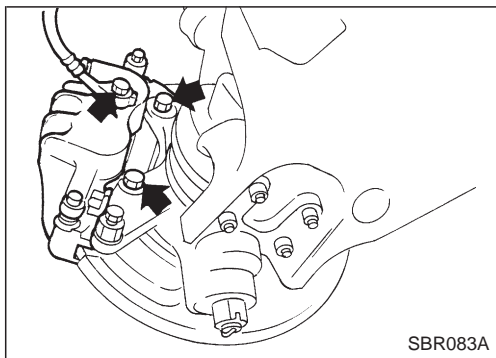
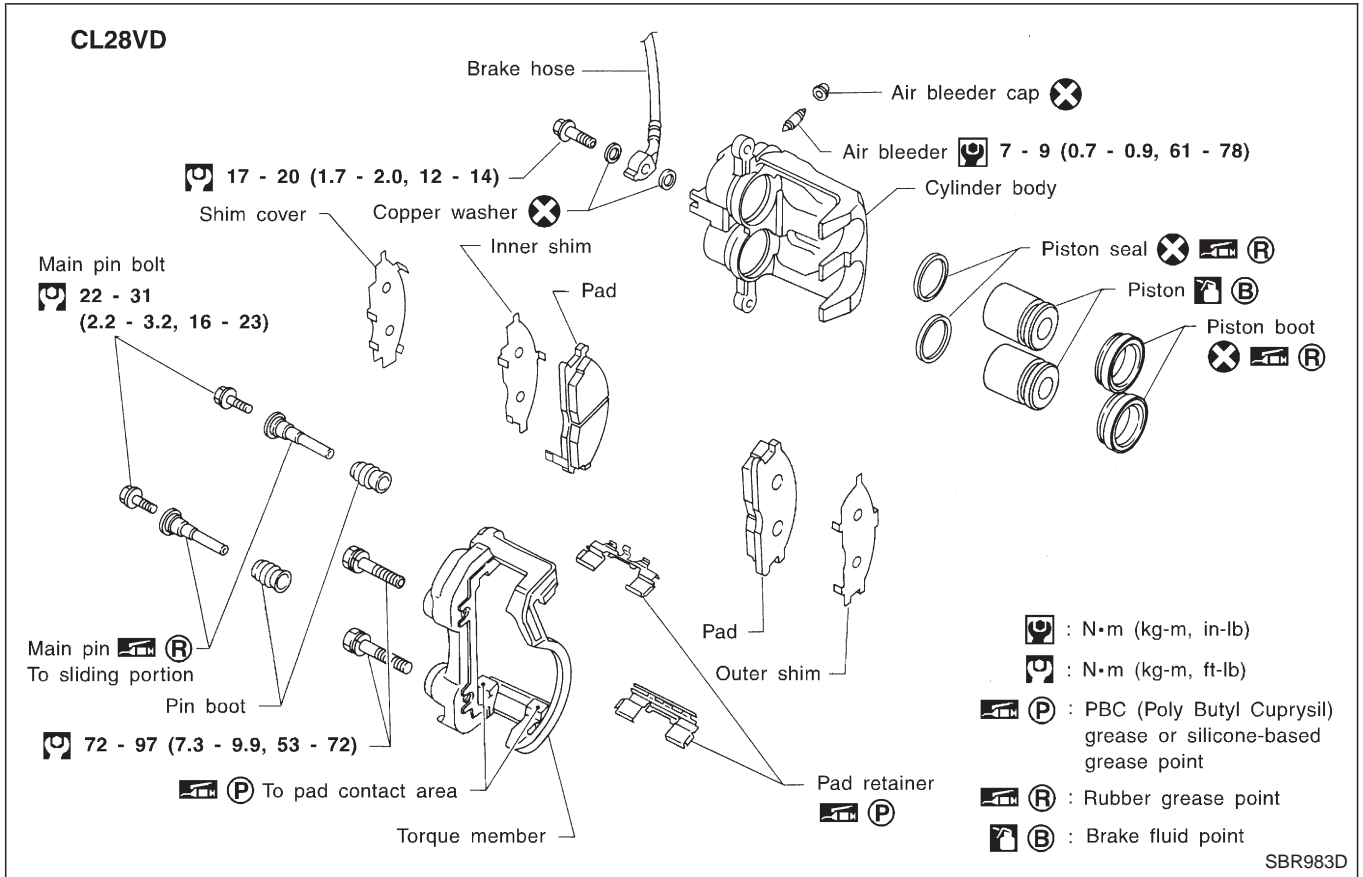

## Removal

### WARNING:

Clean brake pads with a vacuum dust collector to minimize the hazard of airborne materials.

### CAUTION:

Suspend caliper assembly with wire so as not to stretch brake hose.

Remove torque member fixing bolts and connecting bolt.

- It is not necessary to remove connecting bolt except for disassembly or replacement of caliper assembly. In this case, suspend caliper assembly with wire so as not to stretch brake hose.



# FRONT DISC BRAKE

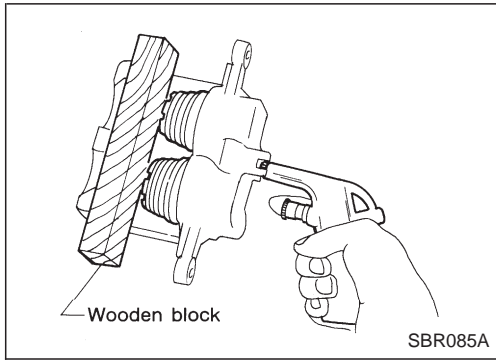

## Disassembly

### WARNING:

Do not place your fingers in front of piston.

### CAUTION:

- Do not scratch or score cylinder wall.
  - CL28VD type front disc brake uses plastic pistons, handle them carefully.
1. Push out piston and dust cover with compressed air. For CL28VD (2-piston type), use a wooden block so that both pistons come out evenly.
  2. Remove piston seal with a suitable tool.

## Inspection — Caliper

### CYLINDER BODY

- Check inside surface of cylinder for score, rust, wear, damage or presence of foreign objects. If any of the above conditions are observed, replace cylinder body.
- Minor damage from rust or foreign objects may be eliminated by polishing the surface with a fine emery sandpaper. Replace cylinder body if necessary.

### CAUTION:

Use brake fluid to clean. Never use mineral oil.

### PISTON

#### — for plastic piston (CL28VD) —

Check pistons for uneven surface, chips or cracks. Replace if any of these conditions are observed.

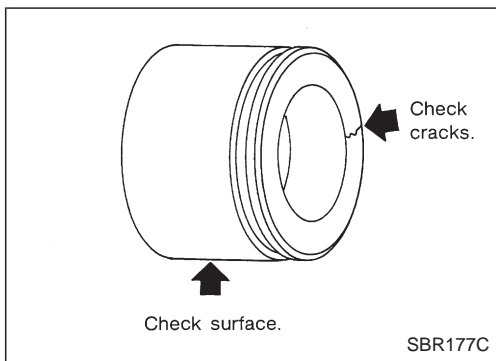

## SLIDE PIN, PIN BOLT AND PIN BOOT

Check for wear, cracks or other damage. Replace if any of these conditions are observed.

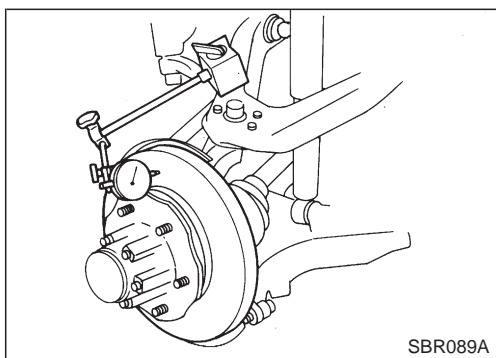

## Inspection — Rotor

### RUNOUT

1. Check runout using a dial indicator.
  - Make sure that wheel bearing axial end play is within the specifications before measuring. Refer to FA section ("Front Wheel Bearing", "ON-VEHICLE SERVICE").

Maximum runout:  
**0.07 mm (0.0028 in)**
2. If the runout is out of specification, machine rotor with on-car brake lathe ("MAD, DL-8700", "AMMCO 700 and 705" or equivalent).

## FRONT DISC BRAKE

### Inspection — Rotor (Cont'd)

#### THICKNESS

Thickness variation (At least 8 positions):

Maximum 0.02 mm (0.0008 in)

If thickness variation exceeds the specification, machine rotor with on-car brake lathe.

**Rotor repair limit:**

**CL28VD 24.0 mm (0.945 in)**

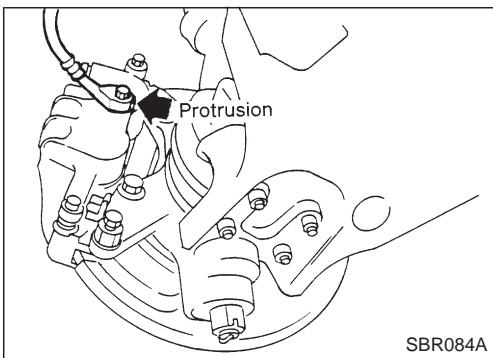
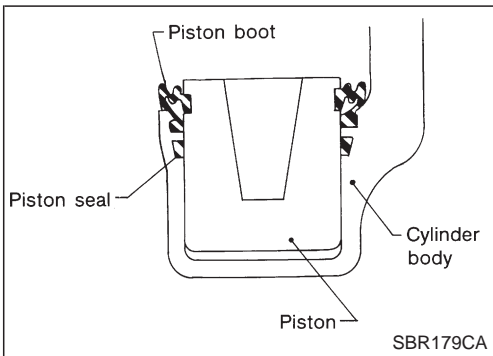
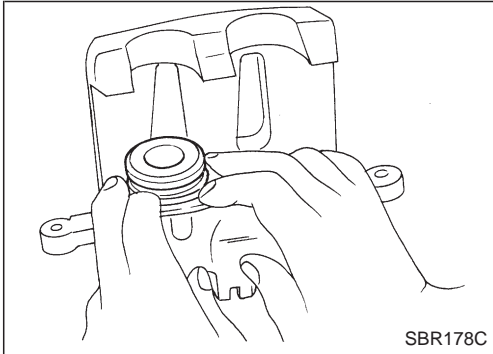
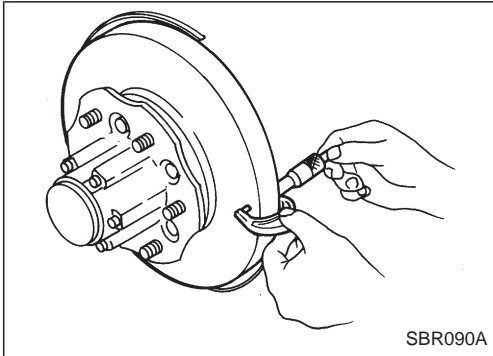

### Assembly

1. Insert piston seal into groove on cylinder body.
2. With piston boot fitted to piston, insert piston boot into groove on cylinder body and install piston.
3. Properly secure piston boot.

#### CAUTION:

- Secure dust seal properly.
- Lubricate with new brake fluid before installing plastic pistons (CL28VD) into cylinder body.

### Installation

#### CAUTION:

- Refill with new brake fluid DOT 3 or DOT 4\*1.
- Never reuse drained brake fluid.

1. Install caliper assembly.
2. Install brake hose to caliper securely.
3. Install all parts and secure all bolts.
4. Bleed air. Refer to "Bleeding Brake System", BR-4.

\*1: Refer to MA section ("Fluids and Lubricants", "RECOMMENDED FLUIDS AND LUBRICANTS").

### Brake Burnishing Procedure

When experiencing soft brake pedal feel at very low mileage, or after replacing the rotor, burnish the brake pad contact surfaces according to the following procedures.

#### CAUTION:

**Only perform this procedure under safe road and traffic conditions. Use extreme caution.**

1. Drive the vehicle on a straight smooth road at 50 km/h (31 MPH).

## FRONT DISC BRAKE

---

### **Brake Burnishing Procedure (Cont'd)**

2. Use medium brake pedal/foot effort to bring the vehicle to a complete stop from 50 km/h (31 MPH). Adjust brake pedal/foot pressure such that vehicle stopping time equals 3 to 5 seconds.
3. To cool the brake system, drive the vehicle at 50 km/h (31 MPH) for 1 minute without stopping.
4. Repeat steps 1 to 3 10 times or more to complete the burnishing procedure.



# REAR DRUM BRAKE

## Removal

### WARNING:

Clean brake lining with a vacuum dust collector to minimize the hazard of airborne materials.

### CAUTION:

Make sure parking brake lever is completely released.

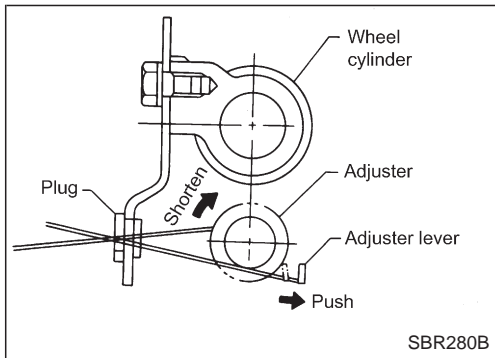

1. Release parking brake lever fully, then remove drum.
  - If drum is hard to remove, the following procedures should be carried out.
  - a. Remove plug. Then shorten adjuster to make clearance between brake shoe and drum.

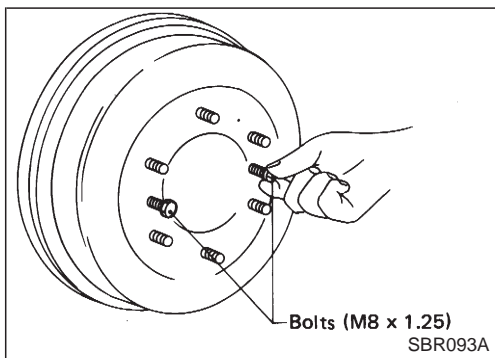

- b. Install two bolts as shown. Tighten the two bolts gradually.

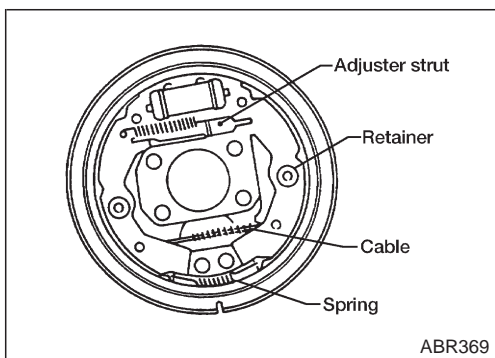

2. After removing retainer, remove spring by rotating shoes.
  - Be careful not to damage wheel cylinder piston boots.
  - Be careful not to damage parking brake cable when separating it.
3. Remove adjuster.
4. Disconnect parking brake cable from toggle lever.

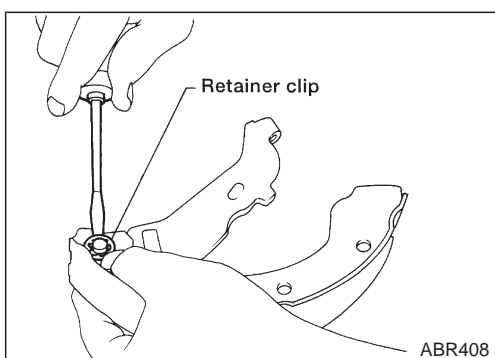

5. Remove retainer clip with a suitable tool. Then separate toggle lever and brake shoe.

# REAR DRUM BRAKE

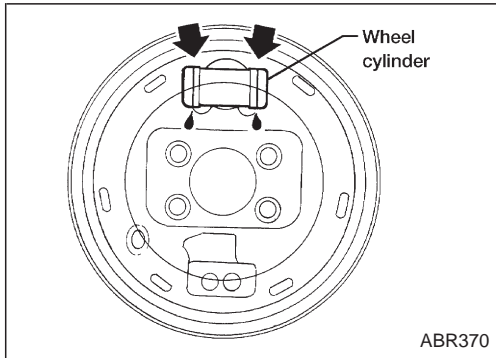

## Inspection — Wheel Cylinder

- Check wheel cylinder for leakage.
- Check for wear, damage and loose conditions. Replace if any such conditions exists.

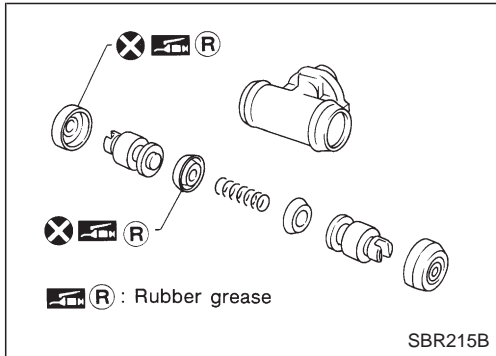

## Wheel Cylinder Overhaul

- Check all internal parts for wear, rust and damage. Replace if necessary.
- Pay attention not to scratch cylinder when installing pistons.

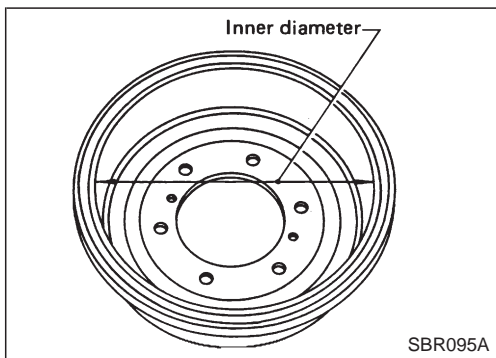

## Inspection — Drum

**Maximum inner diameter (Repair limit):**

**LT26B 261.5 mm (10.30 in)**

**LT30A 296.5 mm (11.67 in)**

- Contact surface should be finished with No. 120 to 150 emery sandpaper.
- Using a brake lathe, machine brake drum if it shows score marks, partial wear or stepped wear.
- After brake drum has been completely reconditioned or replaced, check drum and shoes for proper contact pattern.

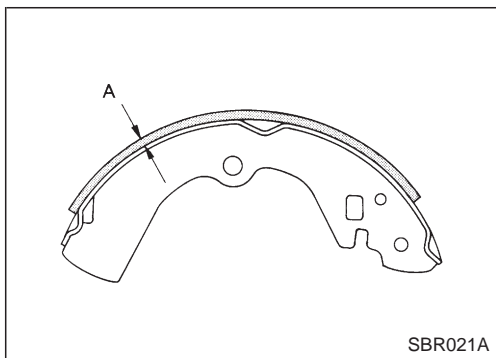

## Inspection — Lining

Check lining thickness.

**Standard lining thickness:**

**LT26B 5.5 mm (0.217 in)**

**LT30A 6.1 mm (0.240 in)**

**Lining wear limit (A):**

**LT26B 1.5 mm (0.059 in)**

**LT30A 1.5 mm (0.059 in)**

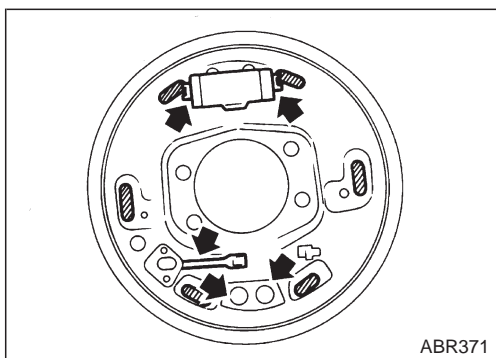

## Installation

- **Always perform shoe clearance adjustment. Refer to BR-31.**
1. Fit toggle lever to brake shoe with retainer clip.
  2. Apply brake grease to the contact areas shown at left.

# REAR DRUM BRAKE

## Installation (Cont'd)

- Shorten adjuster by rotating it.
- **Pay attention to direction of adjuster.**

| Wheel | Screw             |
|-------|-------------------|
| Left  | Left-hand thread  |
| Right | Right-hand thread |

- Connect parking brake cable to toggle lever.
- Install all parts.
- **Be careful not to damage wheel cylinder piston boots.**

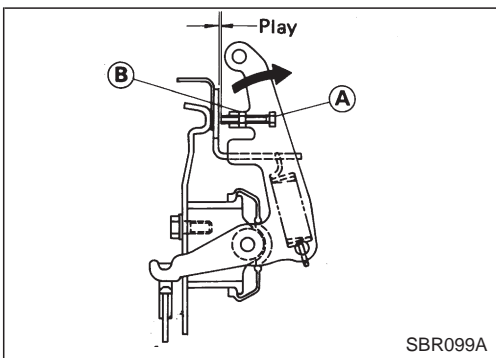
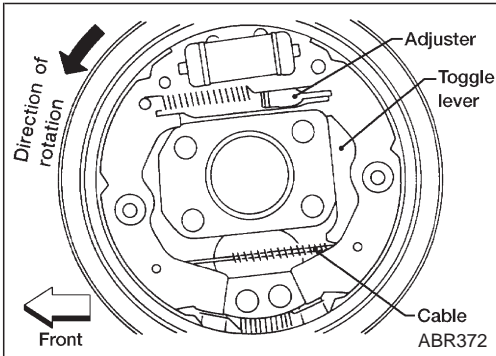
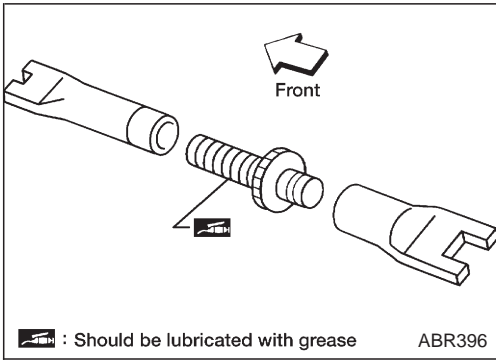

- Check all parts are installed properly.
- **After installation is completed, adjust shoe-to-drum clearance.**
- Install brake drum.
- When installing new wheel cylinder or overhauling wheel cylinder, bleed air. Refer to "Bleeding Brake System", BR-4.
- Adjust parking brake. Refer to BR-31.
- Install all the parts by referring to the figure below.

### LT30A model

- After installing crank lever on back plate, make sure that there is no play between crank lever and back plate. If play exists, adjust bolt (A) and lock nut (B).

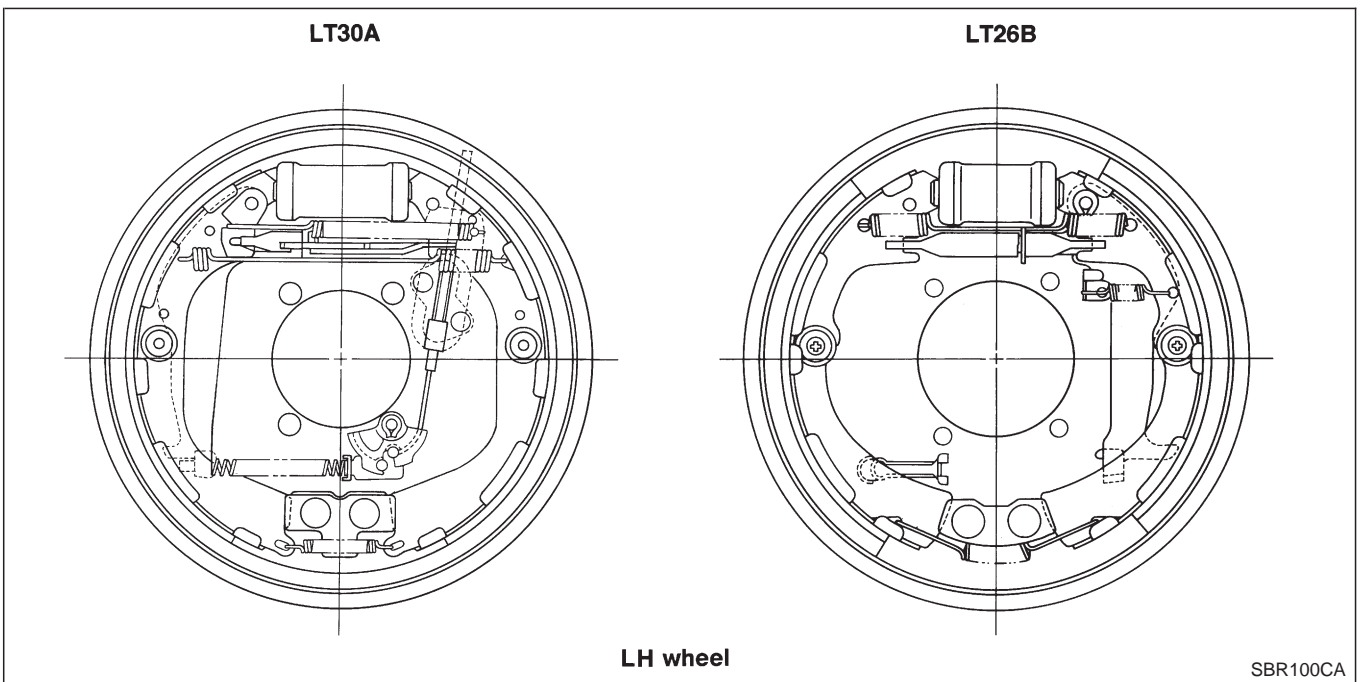







# PARKING BRAKE CONTROL

## Removal and Installation

- Be careful not to damage cable.
- Make sure there is no free play after installation.

## Inspection

1. Check control lever for wear or other damage. Replace if necessary.
2. Check wires for discontinuity or deterioration. Replace if necessary.
3. Check warning lamp and switch. Correct if necessary.
4. Check part at each connecting portion and, if found deformed or damaged, replace.

## Adjustment

Adjust parking brake as follows:

1. Fully release parking brake lever.
2. Loosen (A) and rotate (B) until parking brake cable loosen.
3. Depress brake pedal several times until clicking sound does not occur from rear brakes.
4. Adjust clearance between rear brake shoe and drum.
5. Adjust parking brake lever stroke by rotating (B).
6. Pull parking brake lever with specified force. Check lever stroke and ensure smooth operation.
7. Readjust clearance between rear brake shoe and drum.

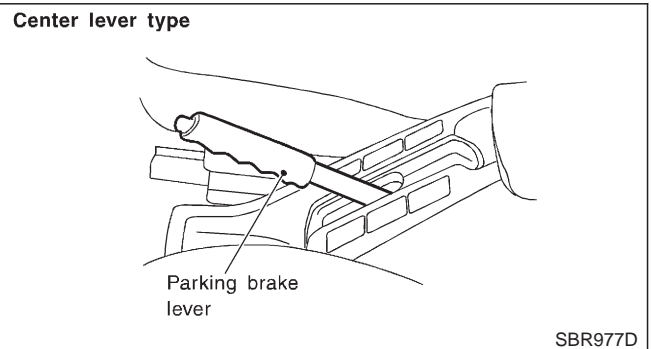
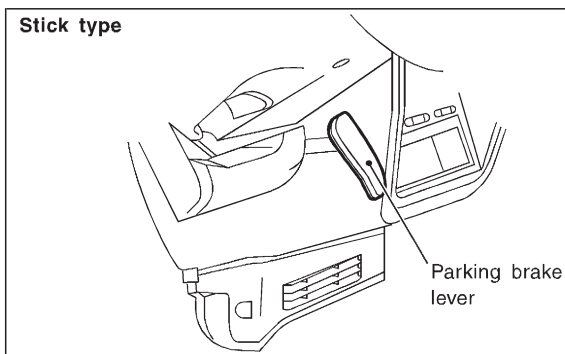
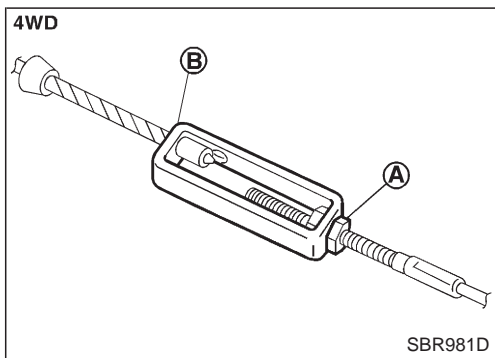
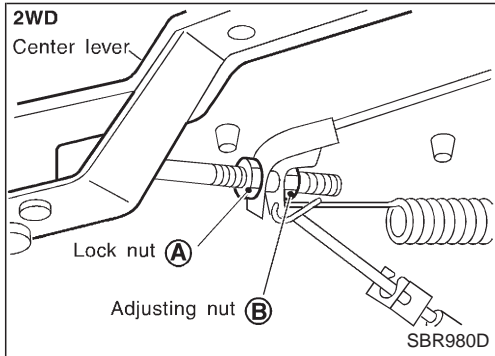

# ANTI-LOCK BRAKE SYSTEM

## Purpose

The Anti-Lock Brake System (ABS) consists of electronic and hydraulic components. It allows for control of braking force so locking of the wheels can be avoided.

The ABS:

- 1) Improves proper tracking performance through steering wheel operation.
- 2) Eases obstacle avoidance through steering wheel operation.
- 3) Improves vehicle stability.

## Operation

- When the vehicle speed is less than 10 km/h (6 MPH) this system does not work.
- The Anti-Lock Brake System (ABS) has a self-test function. The system turns on the ABS warning lamp for 1 second each time the ignition switch is turned "ON". After the engine is started, the ABS warning lamp turns off. The system performs a test the first time the vehicle reaches 6 km/h (4 MPH). A mechanical noise may be heard as the ABS performs this self-test. This is a normal part of the self-test feature. If a malfunction is found during this check, the ABS warning lamp will stay on.
- While driving, a mechanical noise may be heard during ABS operation. This is a normal condition.

## ABS Hydraulic Circuit

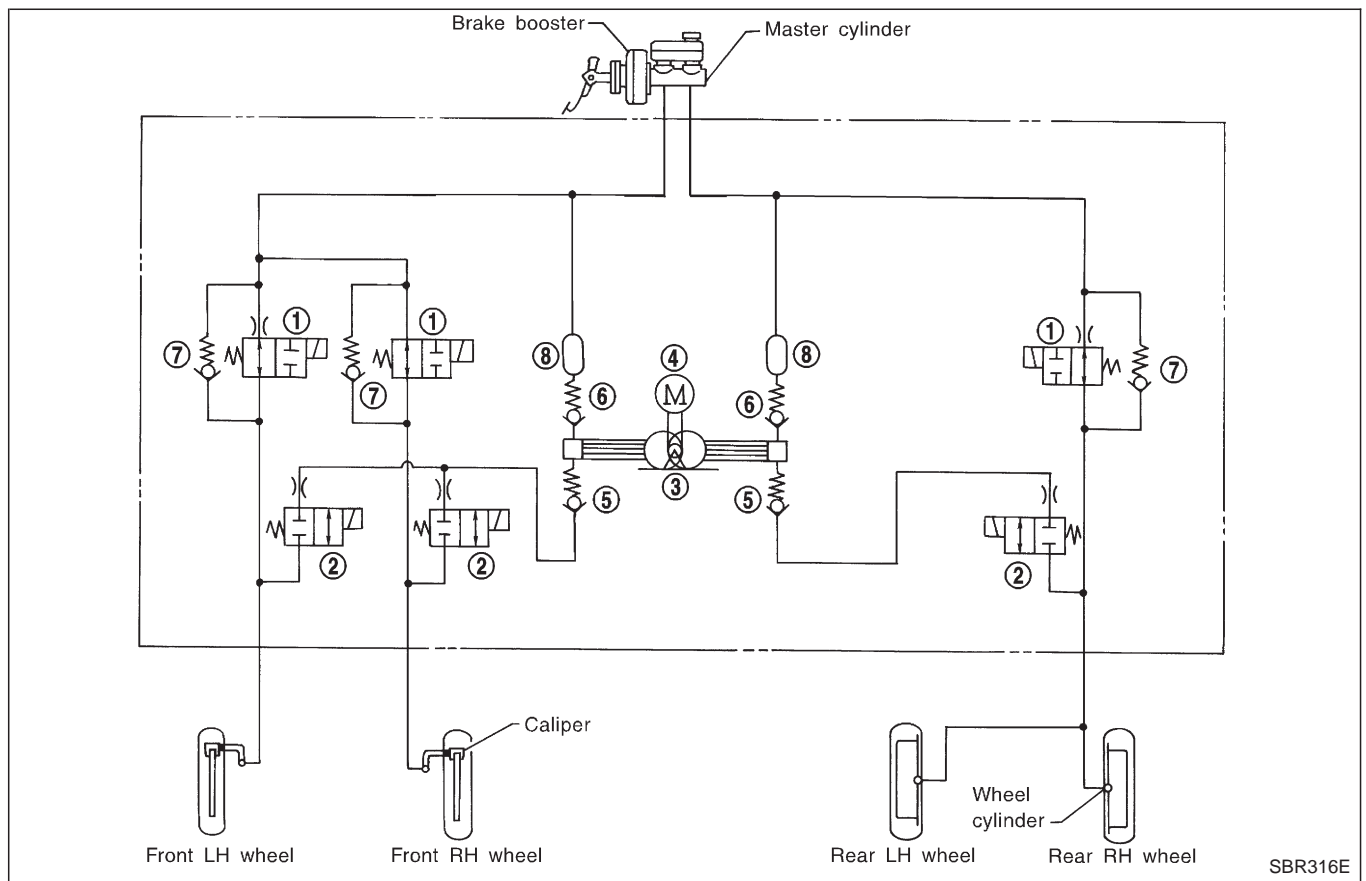

- |                         |                |                      |
|-------------------------|----------------|----------------------|
| ① Inlet solenoid valve  | ④ Motor        | ⑦ Bypass check valve |
| ② Outlet solenoid valve | ⑤ Inlet valve  | ⑧ Damper             |
| ③ Pump                  | ⑥ Outlet valve |                      |

# ANTI-LOCK BRAKE SYSTEM

## System Components

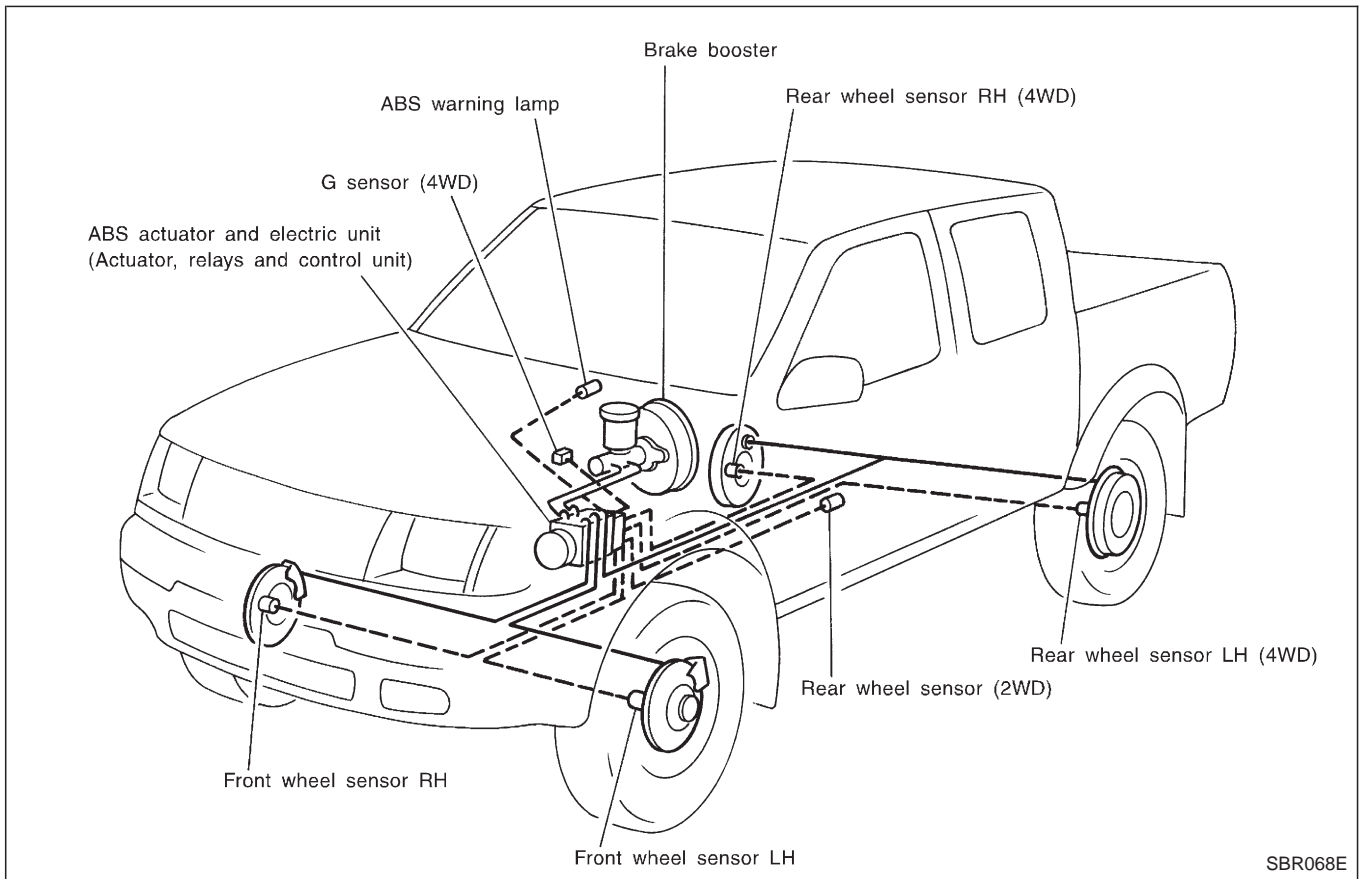

## System Description

### WHEEL SENSOR

The sensor unit consists of a gear-shaped sensor rotor and a sensor element. The element contains a bar magnet around which a coil is wound. The sensor is installed on the back of the brake rotor and the front of the differential (2WD) or the back of the rear brake drum (4WD). As the wheel rotates, the sensor generates a sine-wave pattern. The frequency and voltage increase(s) as the rotating speed increases.

### CONTROL UNIT (built in ABS actuator and electric unit)

The control unit computes the wheel rotating speed by the signal current sent from the sensor. Then it supplies a DC current to the actuator solenoid valve. It also controls ON-OFF operation of the valve relay and motor relay. If any electrical malfunction should be detected in the system, the control unit causes the warning lamp to light up. In this condition, the ABS will be deactivated by the control unit, and the vehicle's brake system reverts to normal operation. (For control unit layout, refer to ABS ACTUATOR AND ELECTRIC UNIT, BR-34.)

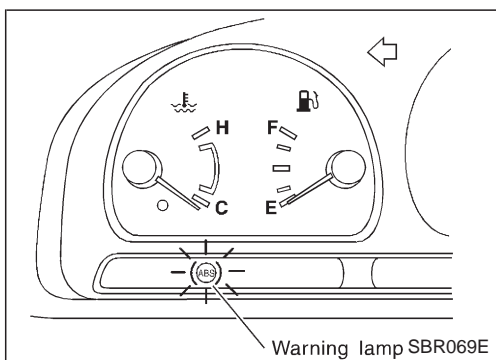

# ANTI-LOCK BRAKE SYSTEM

## System Description (Cont'd)

### G SENSOR (4WD models only)

The G sensor senses deceleration during braking to determine whether the vehicle is being driven on a high  $\mu$  road (asphalt road, etc.) or a low  $\mu$  road (snow-covered road, etc.). It then sends a signal to the ABS control unit.

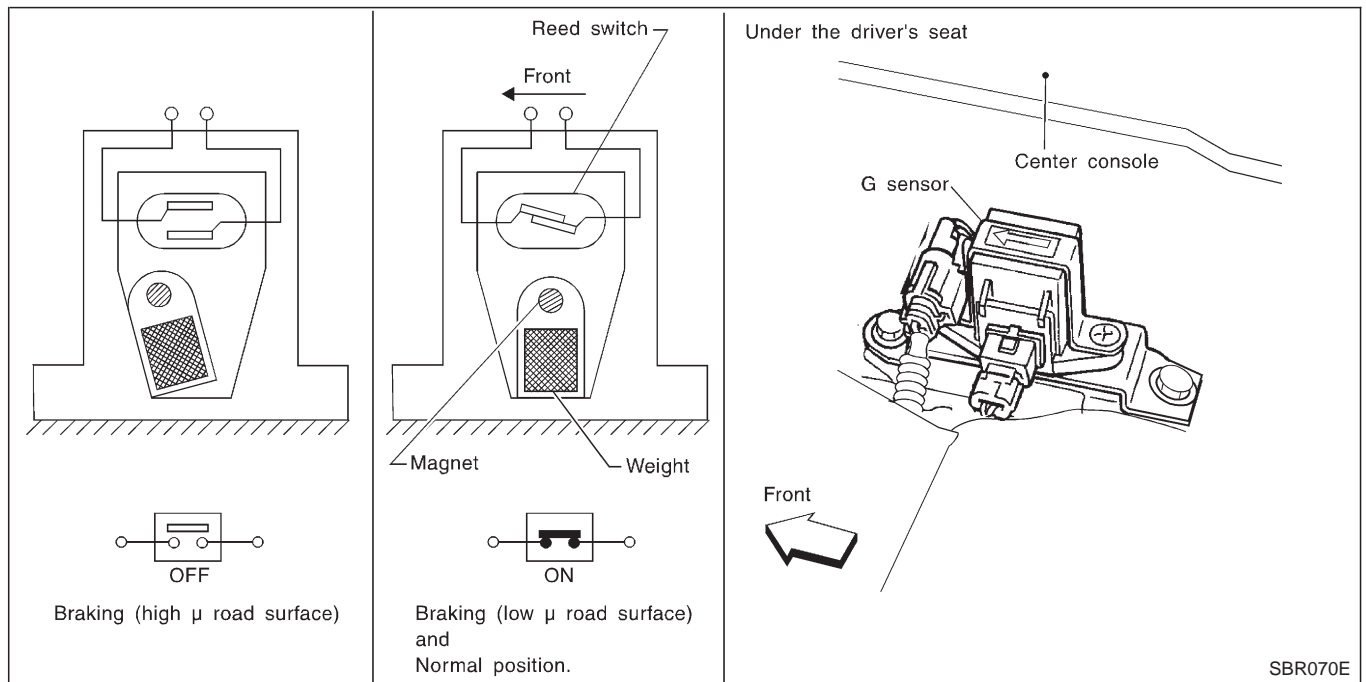

The reed switch turns on when it is affected by a magnetic field. During sudden deceleration (braking on a high  $\mu$  road), the weight moves and the magnet in the weight moves away from the reed switch. The magnetic field then diminishes and the reed switch turns off.

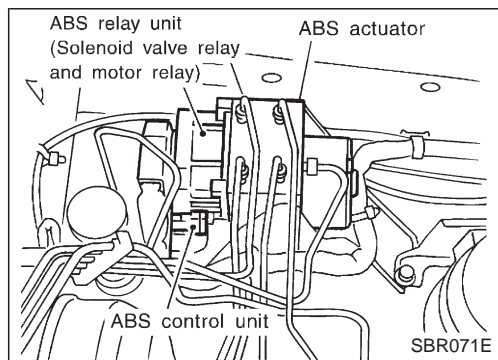

### ABS ACTUATOR AND ELECTRIC UNIT

The ABS actuator and electric unit contains:

- An electric motor and pump
- Two relays
- Six solenoid valves, each inlet and outlet for
  - LH front
  - RH front
  - Rear
- ABS control unit

This component controls the hydraulic circuit and increases, holds or decreases hydraulic pressure to all or individual wheels. The ABS actuator and electric unit are not disassemble.

### ABS actuator operation

|                        |                   | Inlet solenoid valve | Outlet solenoid valve |   |
|------------------------|-------------------|----------------------|-----------------------|---|
| Normal brake operation |                   | OFF (Open)           | OFF (Closed)          | Master cylinder brake fluid pressure is directly transmitted to wheel cylinder via the inlet solenoid valve.                        |
| ABS operation          | Pressure hold     | ON (Closed)          | OFF (Closed)          | Hydraulic circuit is shut off to hold the wheel cylinder brake fluid pressure.  |
|                        | Pressure decrease | ON (Closed)          | ON (Open)             | Wheel cylinder brake fluid is sent to reservoir via the outlet solenoid valve. Then it is pushed up to the master cylinder by pump. |
|                        | Pressure increase | OFF (Open)           | OFF (Closed)          | Master cylinder brake fluid pressure is transmitted to wheel cylinder.  |



# ANTI-LOCK BRAKE SYSTEM

## Removal and Installation (Cont'd)

### REAR WHEEL SENSOR

SEC. 476

2WD

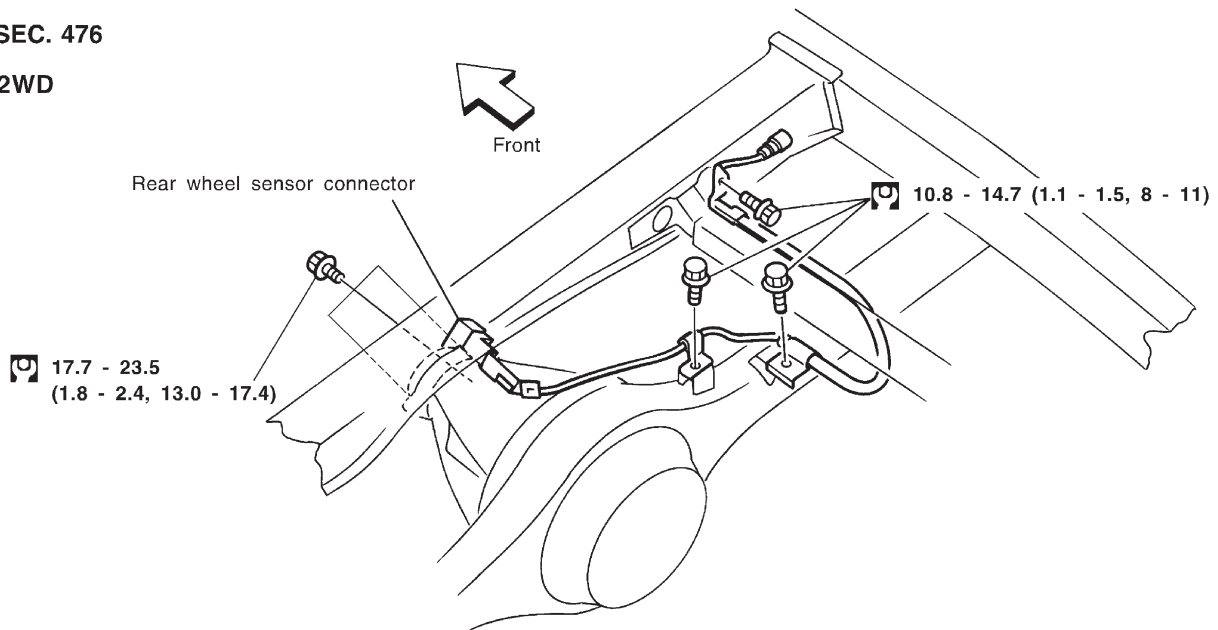

4WD

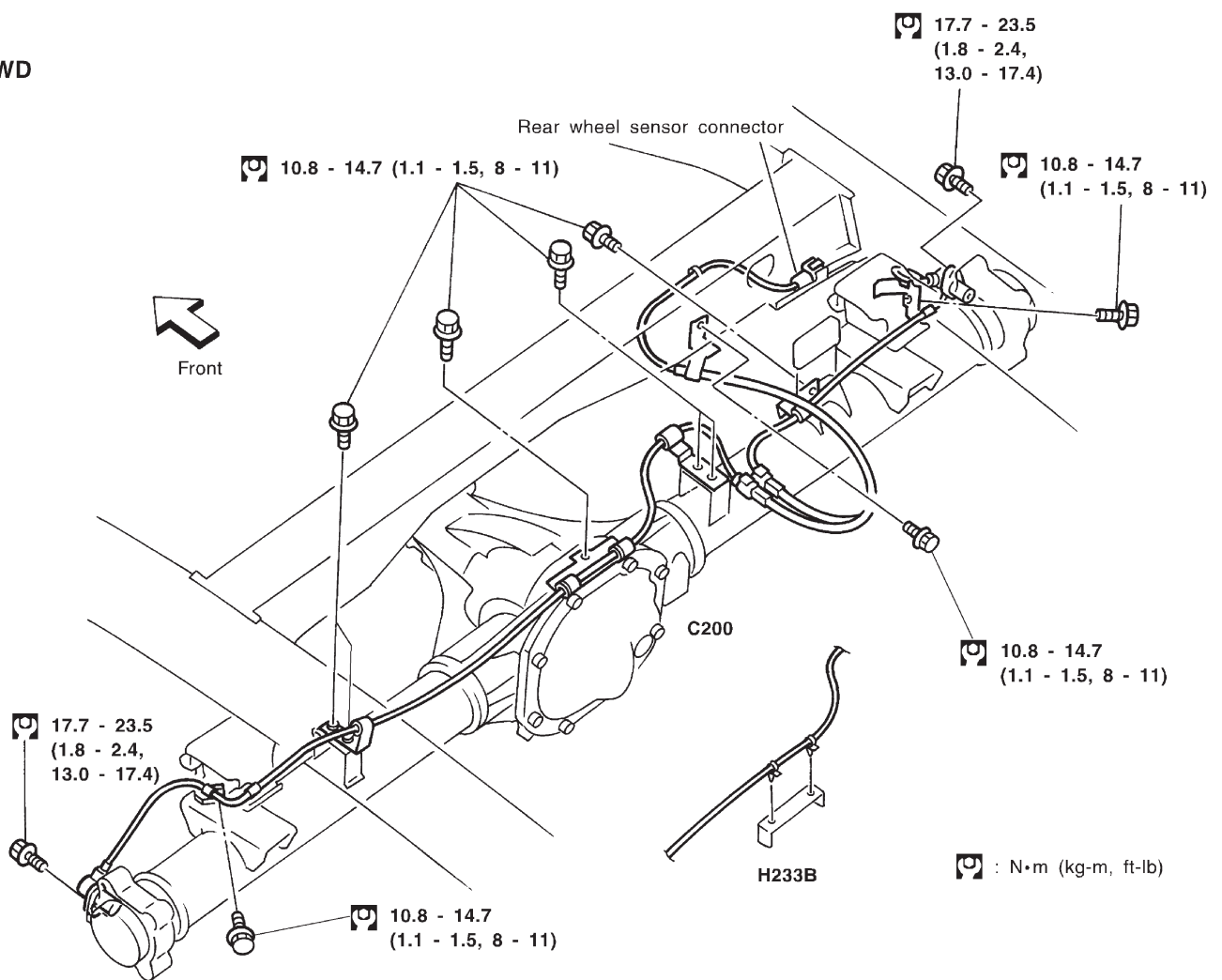

# ANTI-LOCK BRAKE SYSTEM

## Removal and Installation (Cont'd)

### G SENSOR

Always replace G sensor if bumped or dropped. Otherwise, performance characteristics of G sensor will be changed, which in turn changes ABS control performance characteristics.

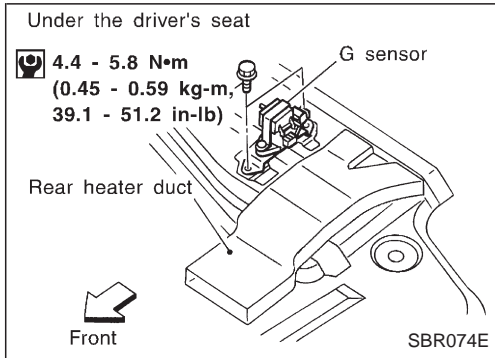

### ABS ACTUATOR AND ELECTRIC UNIT

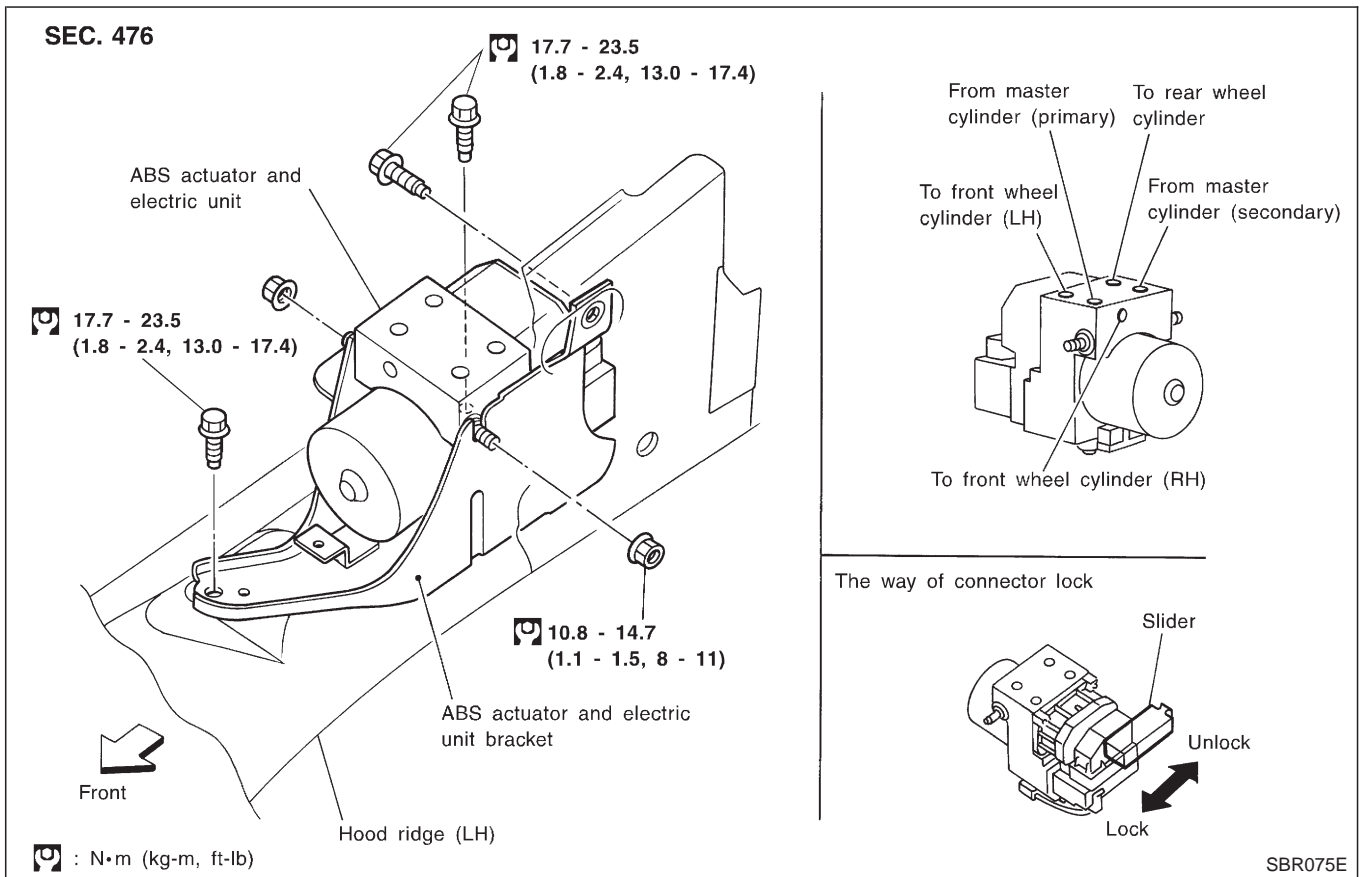

### Removal

1. Disconnect battery cable.
2. Drain brake fluid. Refer to "Changing Brake Fluid", BR-3.
3. Remove mounting bracket fixing bolts and nuts.
4. Disconnect connector, brake pipes and remove fixing nuts.

### Installation

#### CAUTION:

After installation, refill brake fluid. Then bleed air. Refer to "Bleeding Brake System", BR-4.

1. Connect brake pipes temporarily.
2. Tighten fixing bolts and nuts.
3. Tighten brake pipes.
4. Connect connector and battery cable.



## TROUBLE DIAGNOSES

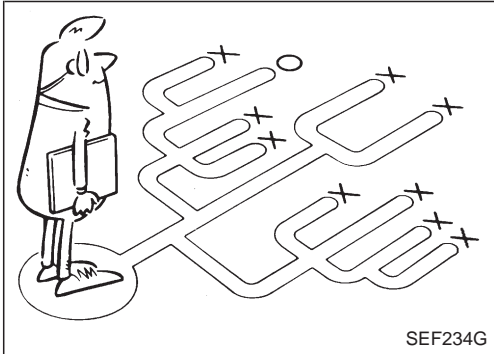
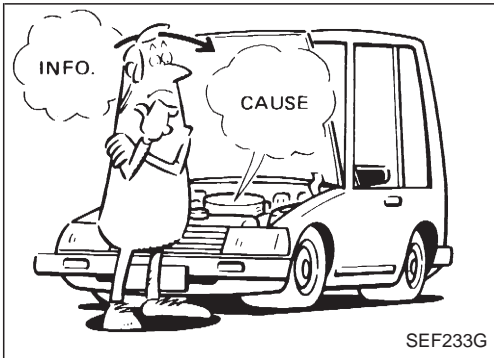

### How to Perform Trouble Diagnoses for Quick and Accurate Repair

#### INTRODUCTION

The ABS system has an electronic control unit to control major functions. The control unit accepts input signals from sensors and instantly drives the actuators. It is essential that both kinds of signals are proper and stable. It is also important to check for conventional problems: such as air leaks in booster lines, lack of brake fluid, or other problems with the brake system.

It is much more difficult to diagnose a problem that occurs intermittently rather than continuously. Most intermittent problems are caused by poor electric connections or faulty wiring. In this case, careful checking of suspicious circuits may help prevent the replacement of good parts.

A visual check only may not find the cause of the problems, so a road test should be performed.

Before undertaking actual checks, take a few minutes to talk with a customer who approaches with a ABS complaint. The customer is a very good source of information on such problems; especially intermittent ones. Through the talks with the customer, find out what symptoms are present and under what conditions they occur.

Start your diagnosis by looking for "conventional" problems first. This is one of the best ways to troubleshoot brake problems on an ABS controlled vehicle.



# TROUBLE DIAGNOSES

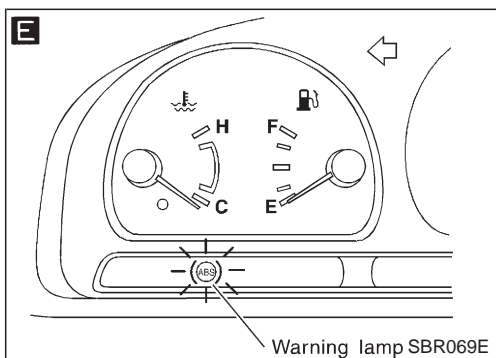
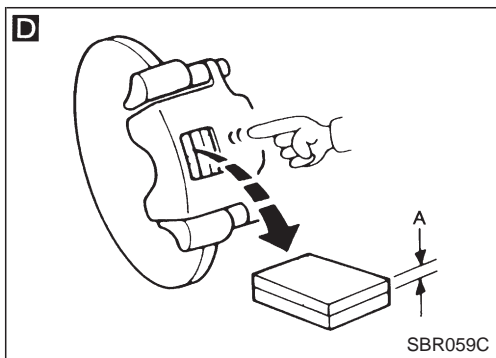
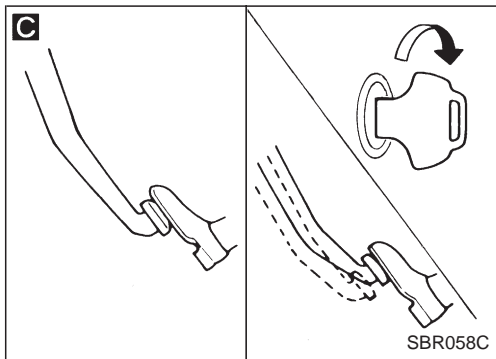
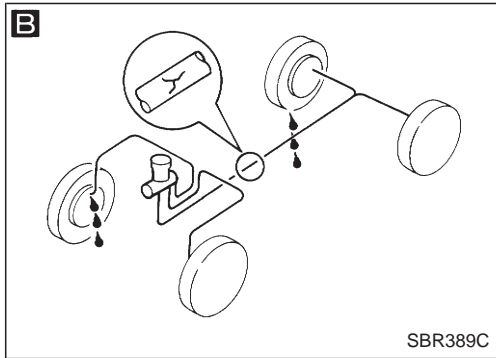
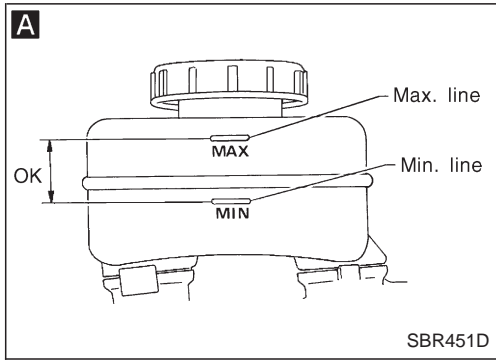

## Preliminary Check

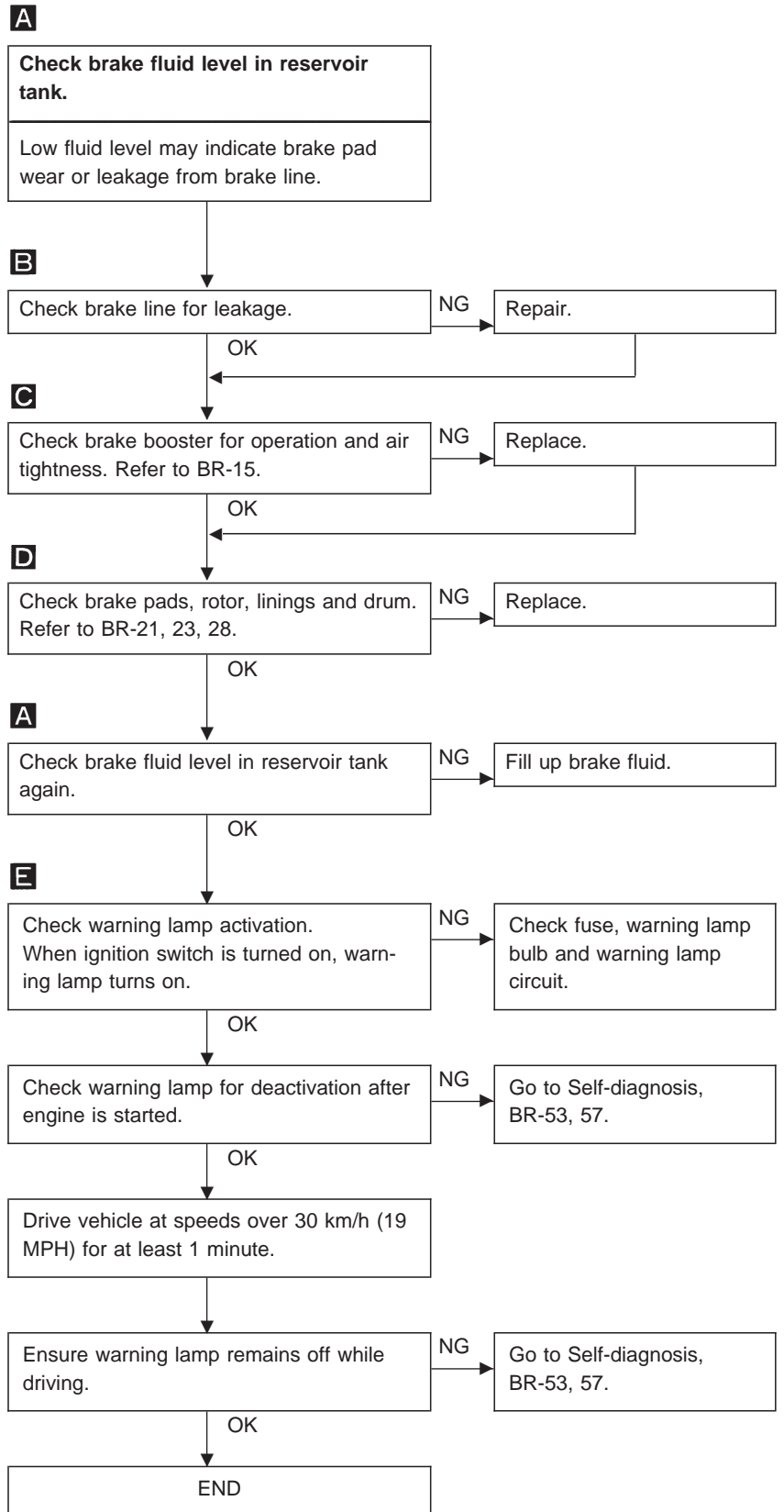

# TROUBLE DIAGNOSES

## Component Parts and Harness Connector Location

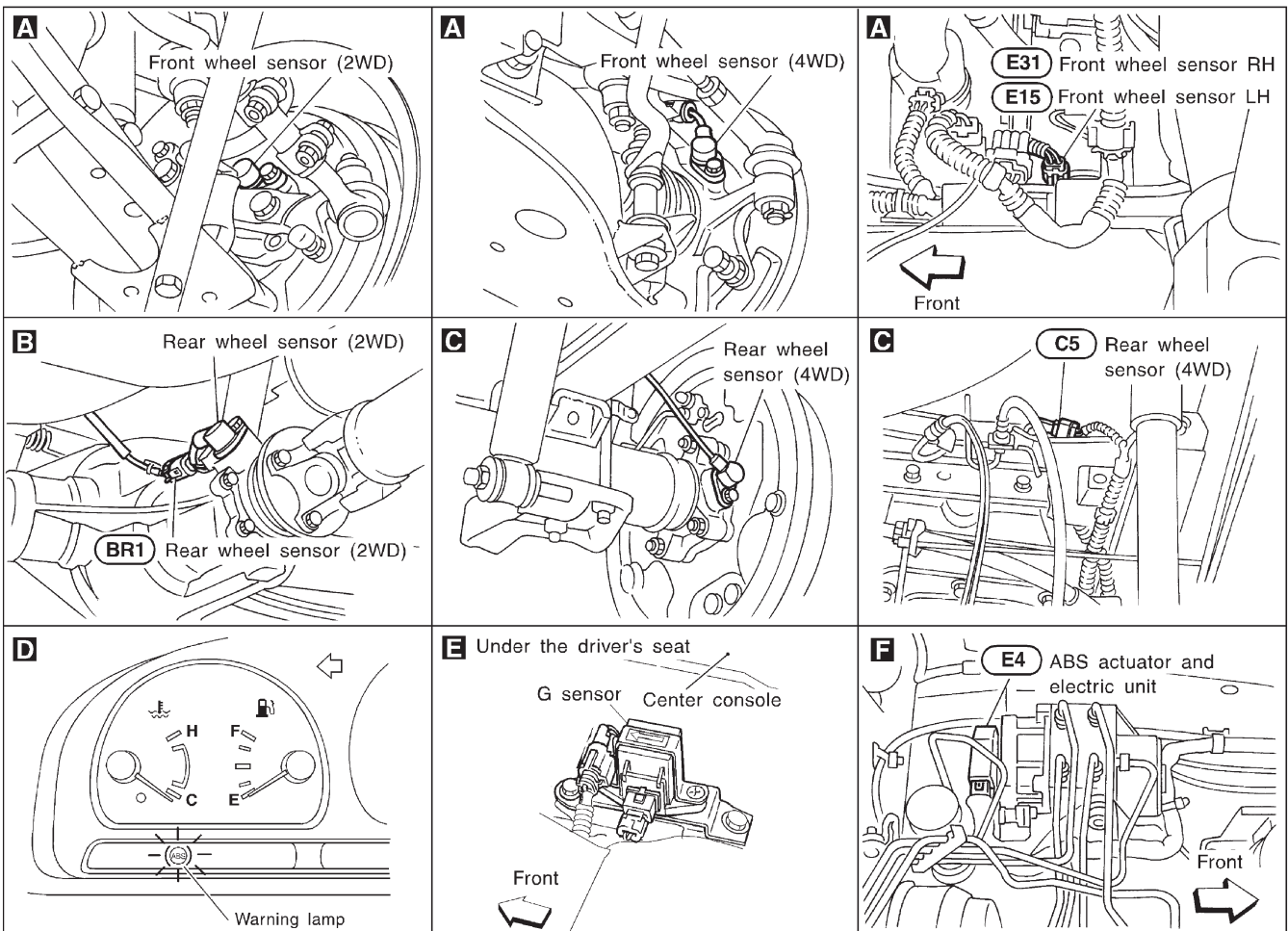
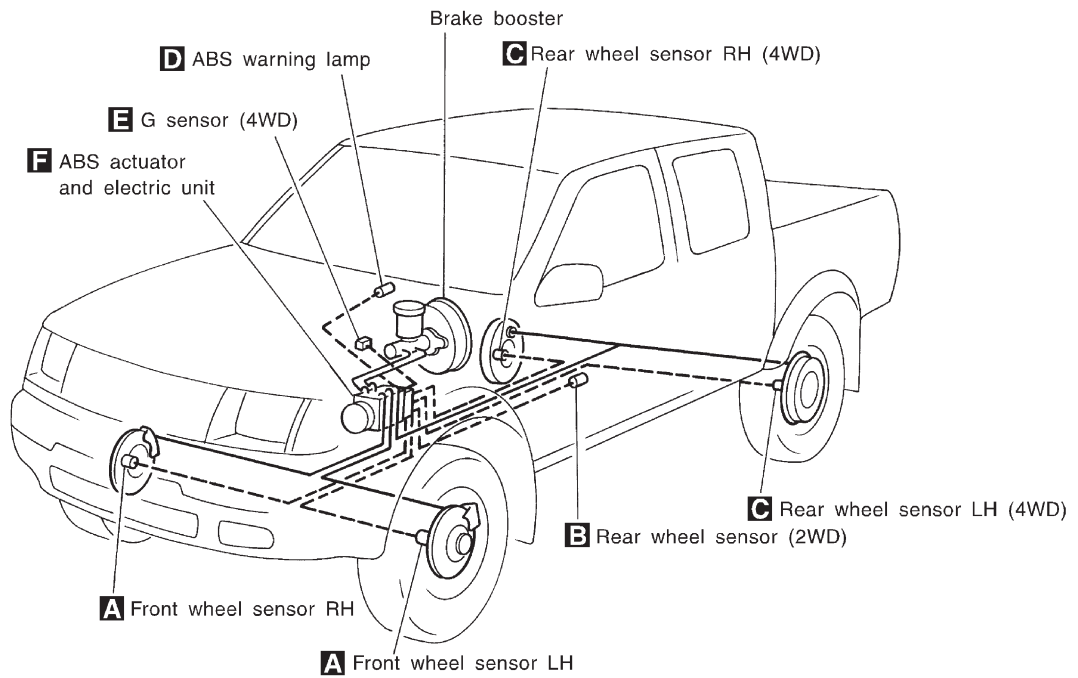

# TROUBLE DIAGNOSES

## Schematic/2WD Models

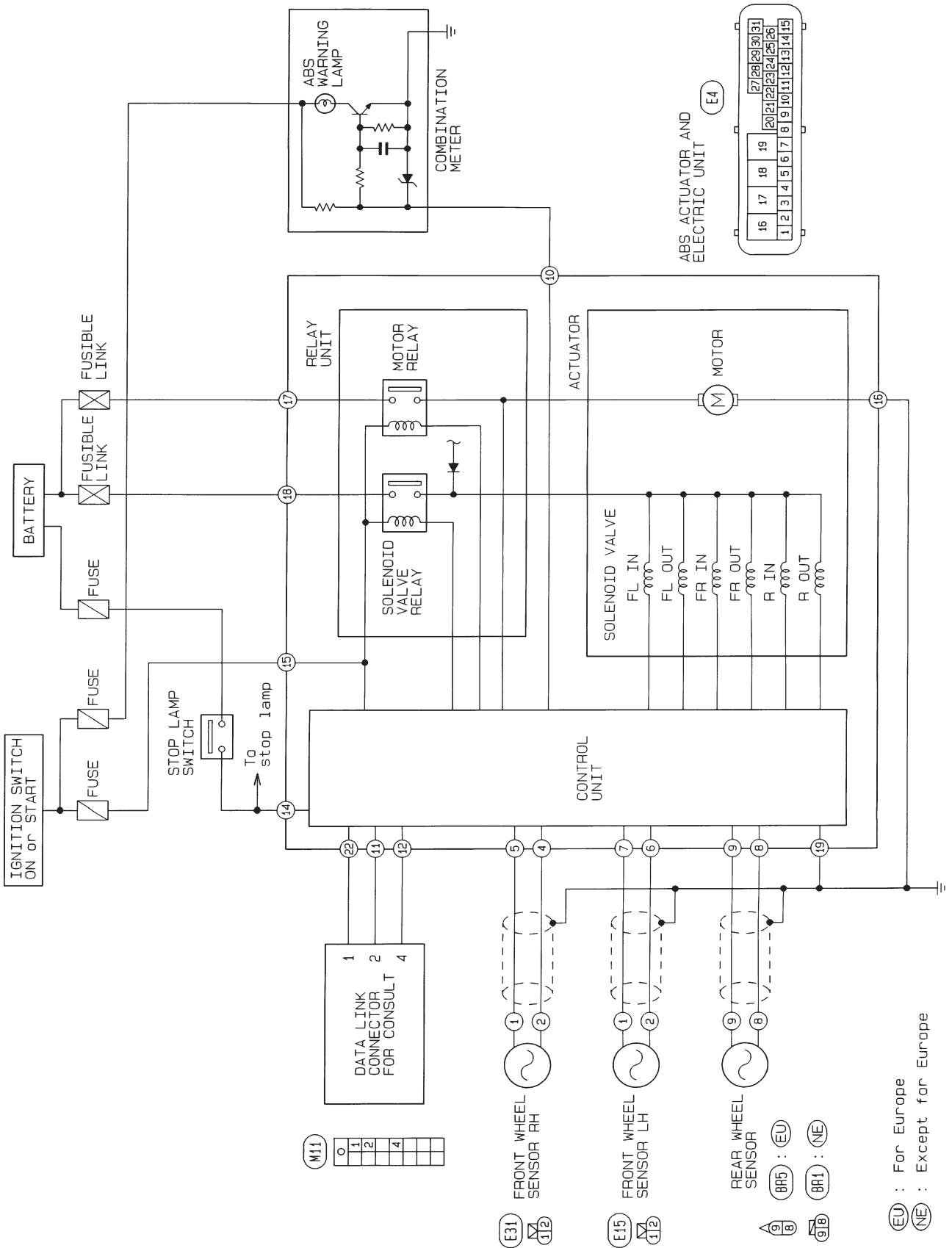

# TROUBLE DIAGNOSES

## Wiring Diagram — ABS —/2WD LHD Models

BR-ABS-01

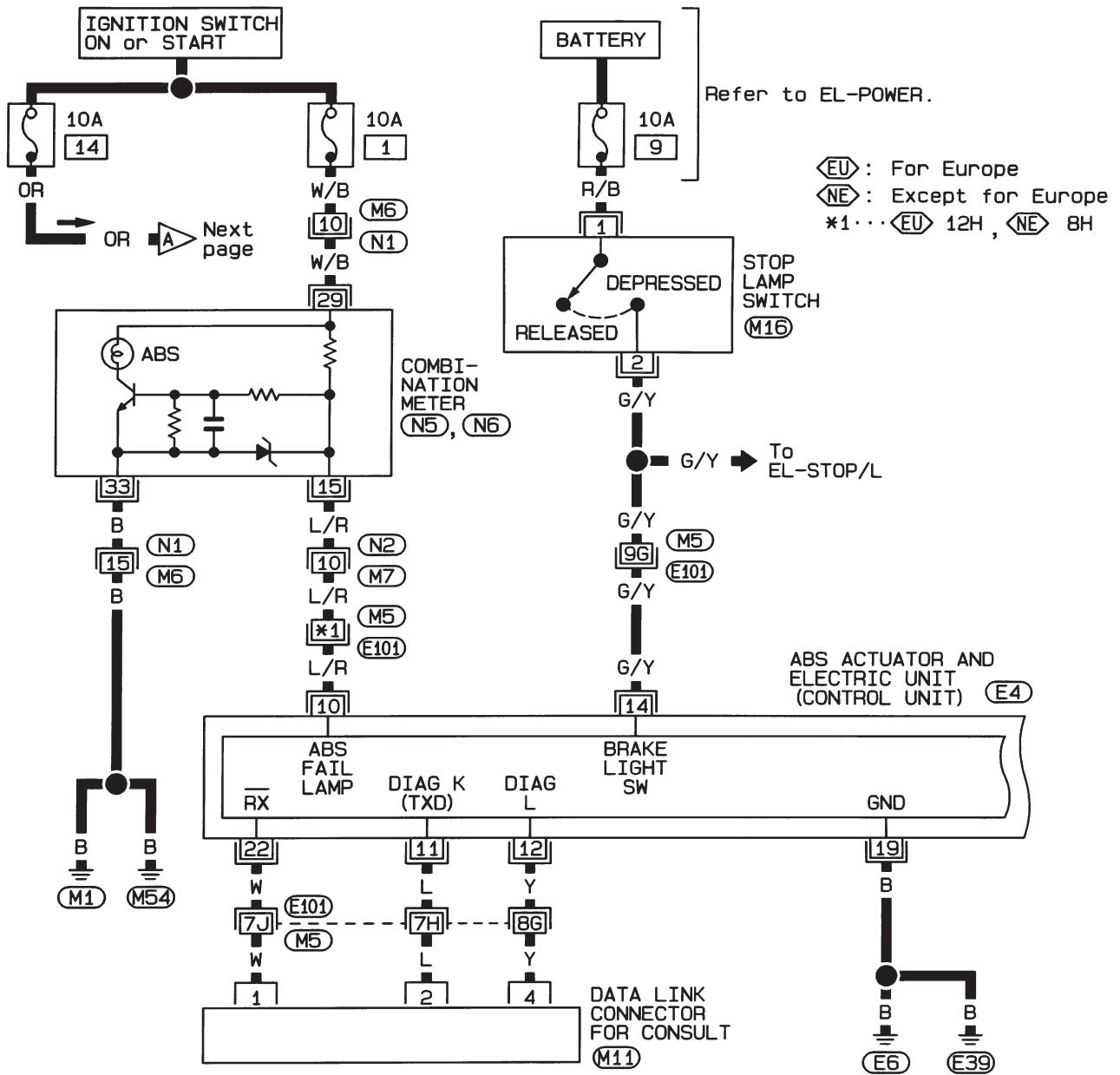

Refer to last page (Foldout page).

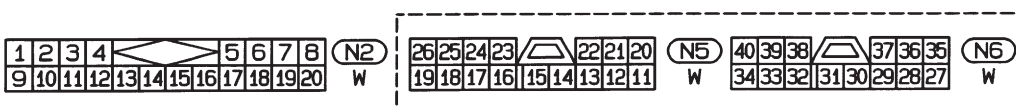

(M5), (E101)

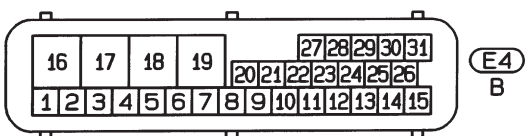

# TROUBLE DIAGNOSES

## Wiring Diagram — ABS —/2WD LHD Models (Cont'd)

BR-ABS-02

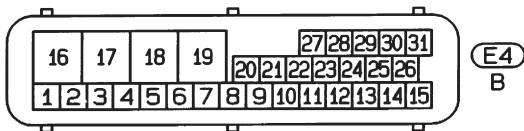
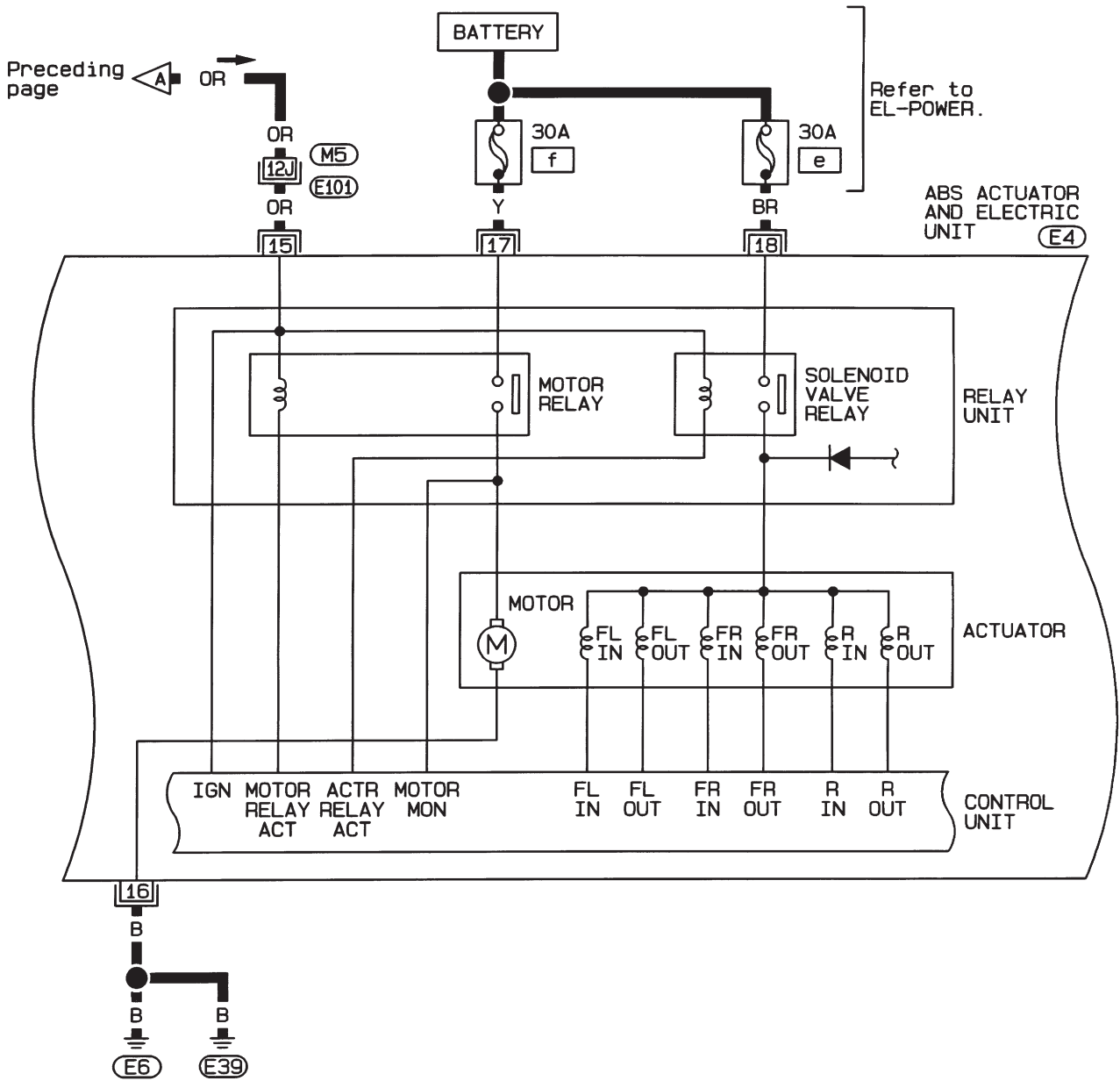

Refer to last page (Foldout page).

(M5), (E101)

# TROUBLE DIAGNOSES

## Wiring Diagram — ABS —/2WD LHD Models (Cont'd)

BR-ABS-03

EU : For Europe  
NE : Except for Europe

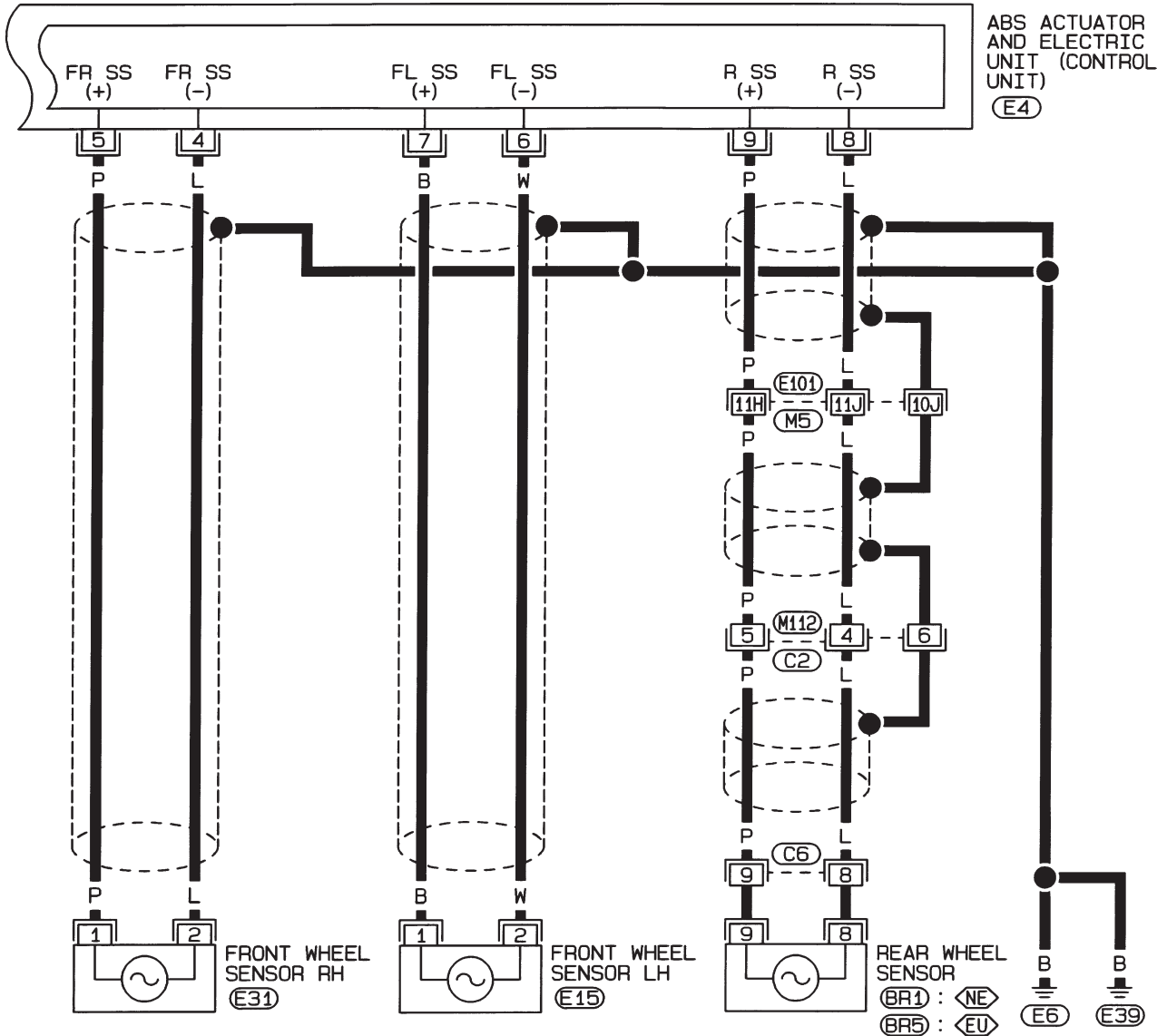

Refer to last page (Foldout page).

(M5), (E101)

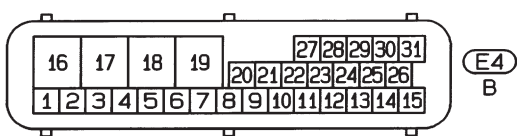

\* : This connector is not shown in "HARNES LAYOUT", EL section.

# TROUBLE DIAGNOSES

## Wiring Diagram — ABS —/2WD RHD Models

BR-ABS-04

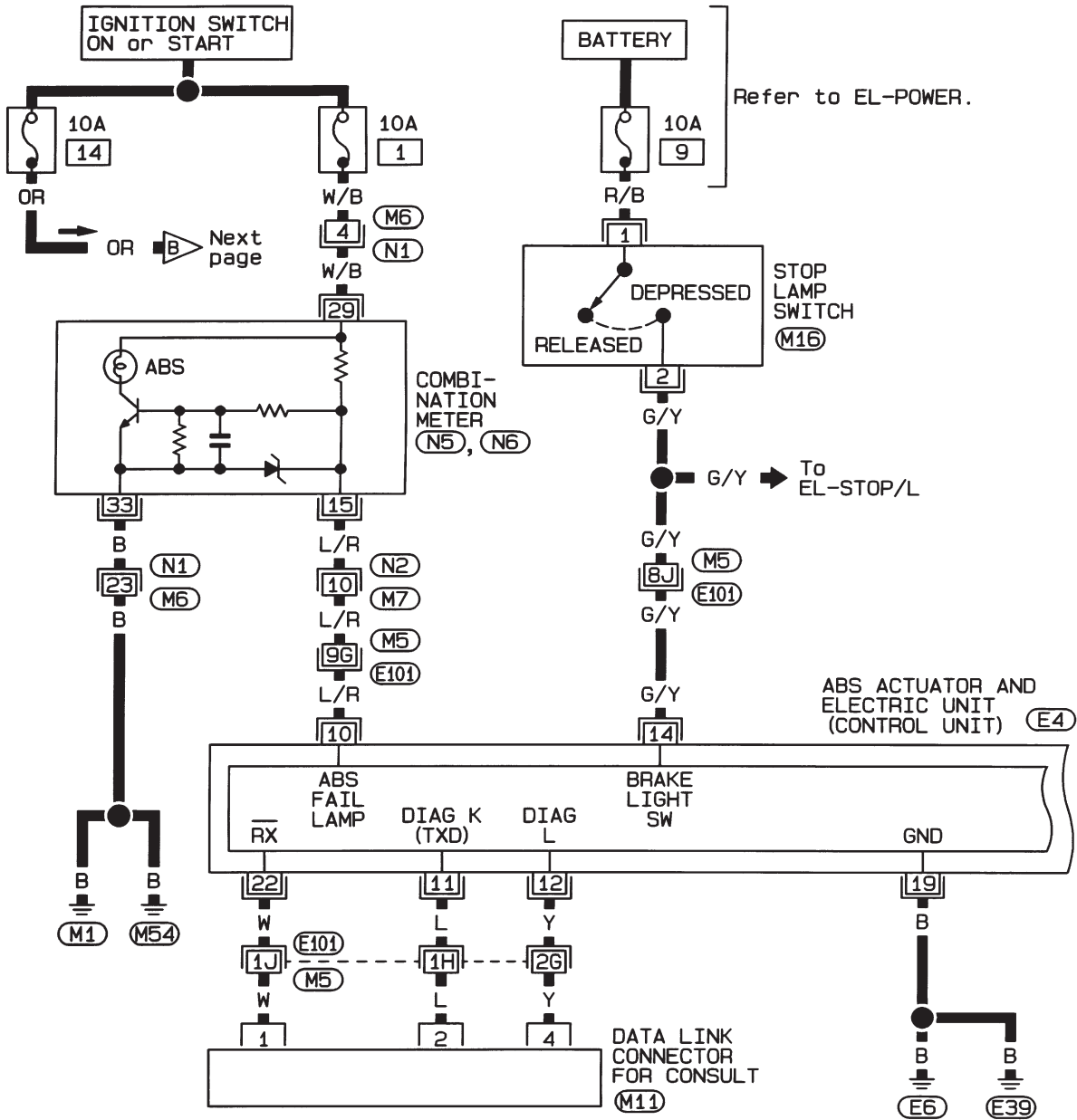

|   |   |    |    |    |    |    |     |
|---|---|----|----|----|----|----|-----|
| 1 | 2 | 3  | 4  | 5  | 6  | 7  | M11 |
| 8 | 9 | 10 | 11 | 12 | 13 | 14 | GY  |

|   |   |     |
|---|---|-----|
| 1 | 2 | M16 |
|   |   | B   |

|    |    |    |    |    |    |    |    |    |    |    |    |    |    |   |
|----|----|----|----|----|----|----|----|----|----|----|----|----|----|---|
| 1  | 2  | 3  | 4  | 5  | 6  | 7  | 8  | 9  | 10 | N1 |    |    |    |   |
| 11 | 12 | 13 | 14 | 15 | 16 | 17 | 18 | 19 | 20 | 21 | 22 | 23 | 24 | W |

|   |    |    |    |    |    |    |    |    |    |    |    |   |
|---|----|----|----|----|----|----|----|----|----|----|----|---|
| 1 | 2  | 3  | 4  | 5  | 6  | 7  | 8  | N2 |    |    |    |   |
| 9 | 10 | 11 | 12 | 13 | 14 | 15 | 16 | 17 | 18 | 19 | 20 | W |

|    |    |    |    |    |    |    |    |    |    |    |    |    |    |    |    |    |    |   |
|----|----|----|----|----|----|----|----|----|----|----|----|----|----|----|----|----|----|---|
| 26 | 25 | 24 | 23 | 22 | 21 | 20 | N5 | 40 | 39 | 38 | 37 | 36 | 35 | N6 |    |    |    |   |
| 19 | 18 | 17 | 16 | 15 | 14 | 13 | 12 | 11 | W  | 34 | 33 | 32 | 31 | 30 | 29 | 28 | 27 | W |

|    |    |    |    |    |    |    |    |    |    |    |    |    |    |    |    |    |
|----|----|----|----|----|----|----|----|----|----|----|----|----|----|----|----|----|
| 16 | 17 | 18 | 19 | 20 | 21 | 22 | 23 | 24 | 25 | 26 | 27 | 28 | 29 | 30 | 31 | E4 |
| 1  | 2  | 3  | 4  | 5  | 6  | 7  | 8  | 9  | 10 | 11 | 12 | 13 | 14 | 15 | B  |    |

Refer to last page (Foldout page).

(M5), (E101)

# TROUBLE DIAGNOSES

## Wiring Diagram — ABS —/2WD RHD Models (Cont'd)

BR-ABS-05

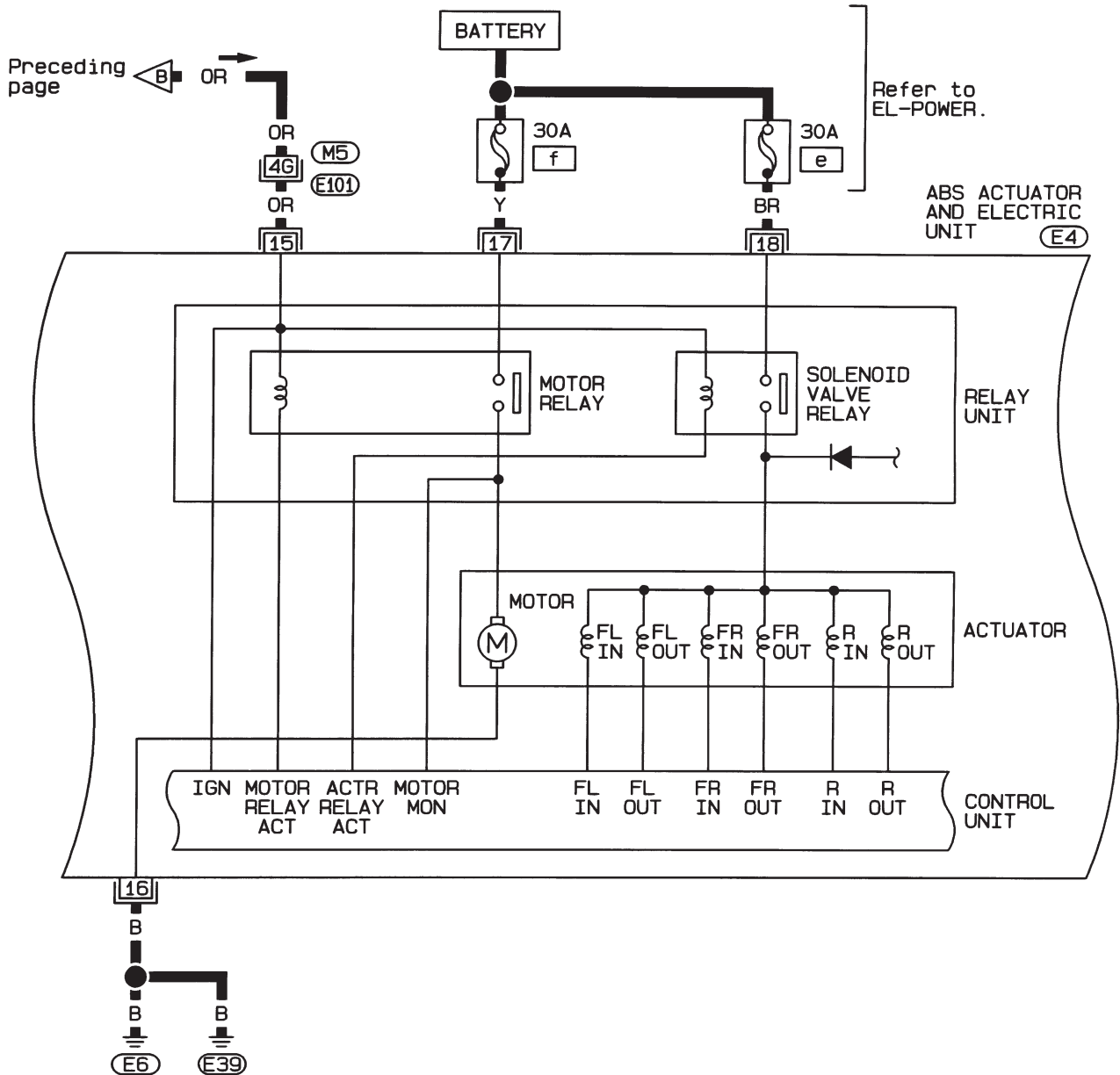

Refer to EL-POWER.

ABS ACTUATOR AND ELECTRIC UNIT (E4)

RELAY UNIT

ACTUATOR

CONTROL UNIT

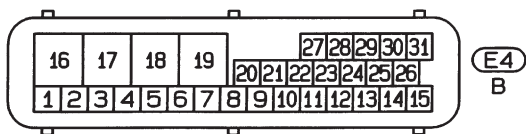

Refer to last page (Foldout page).

(M5), (E101)



# TROUBLE DIAGNOSES

## Wiring Diagram — ABS —/2WD RHD Models (Cont'd)

BR-ABS-06

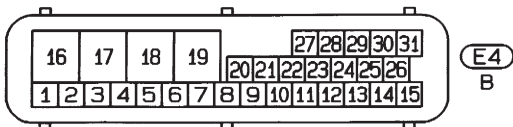
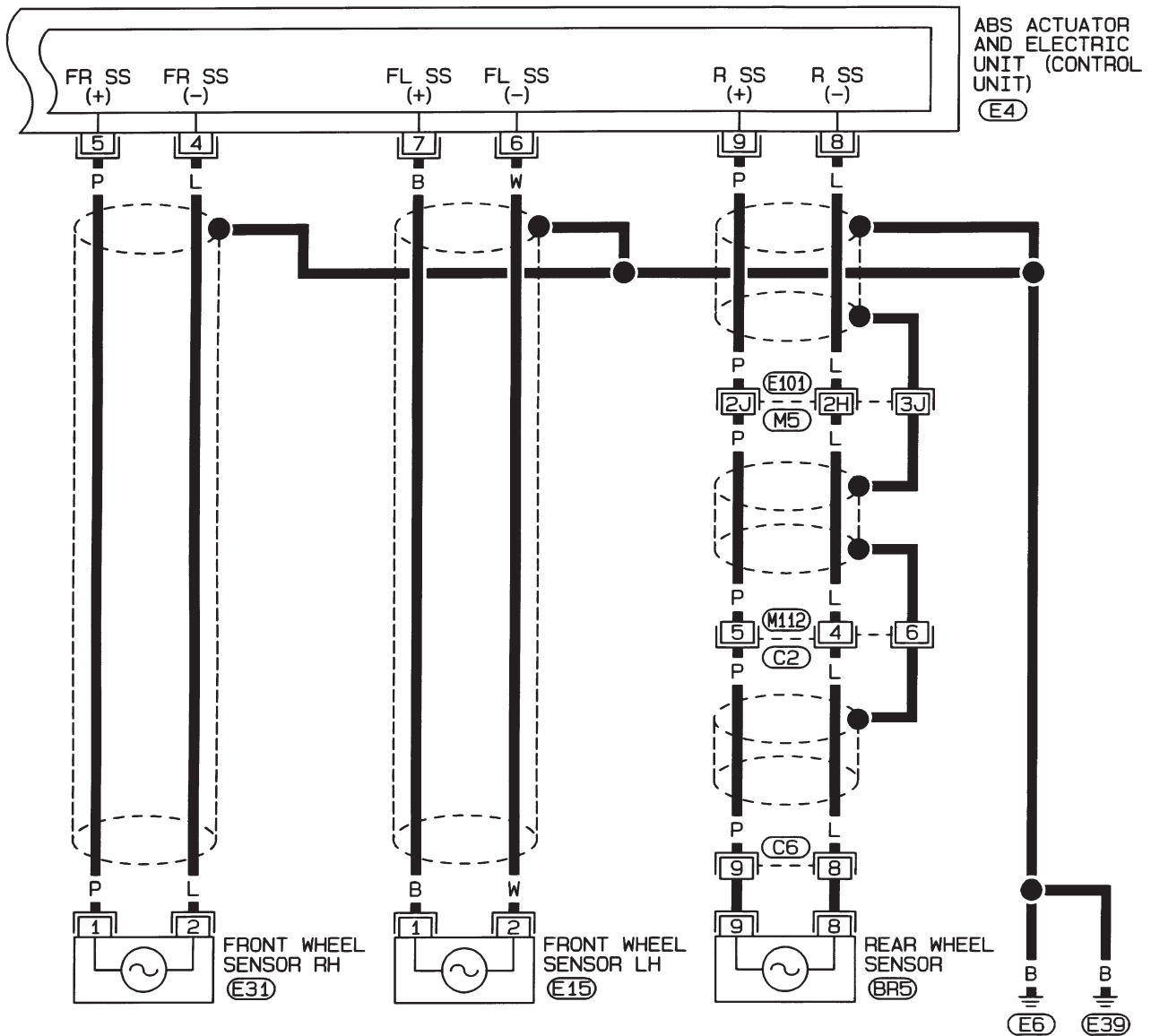

Refer to last page (Foldout page).

M5, E101

\* : This connector is not shown in "HARNES LAYOUT", EL section.

# TROUBLE DIAGNOSES

## Schematic/4WD Models

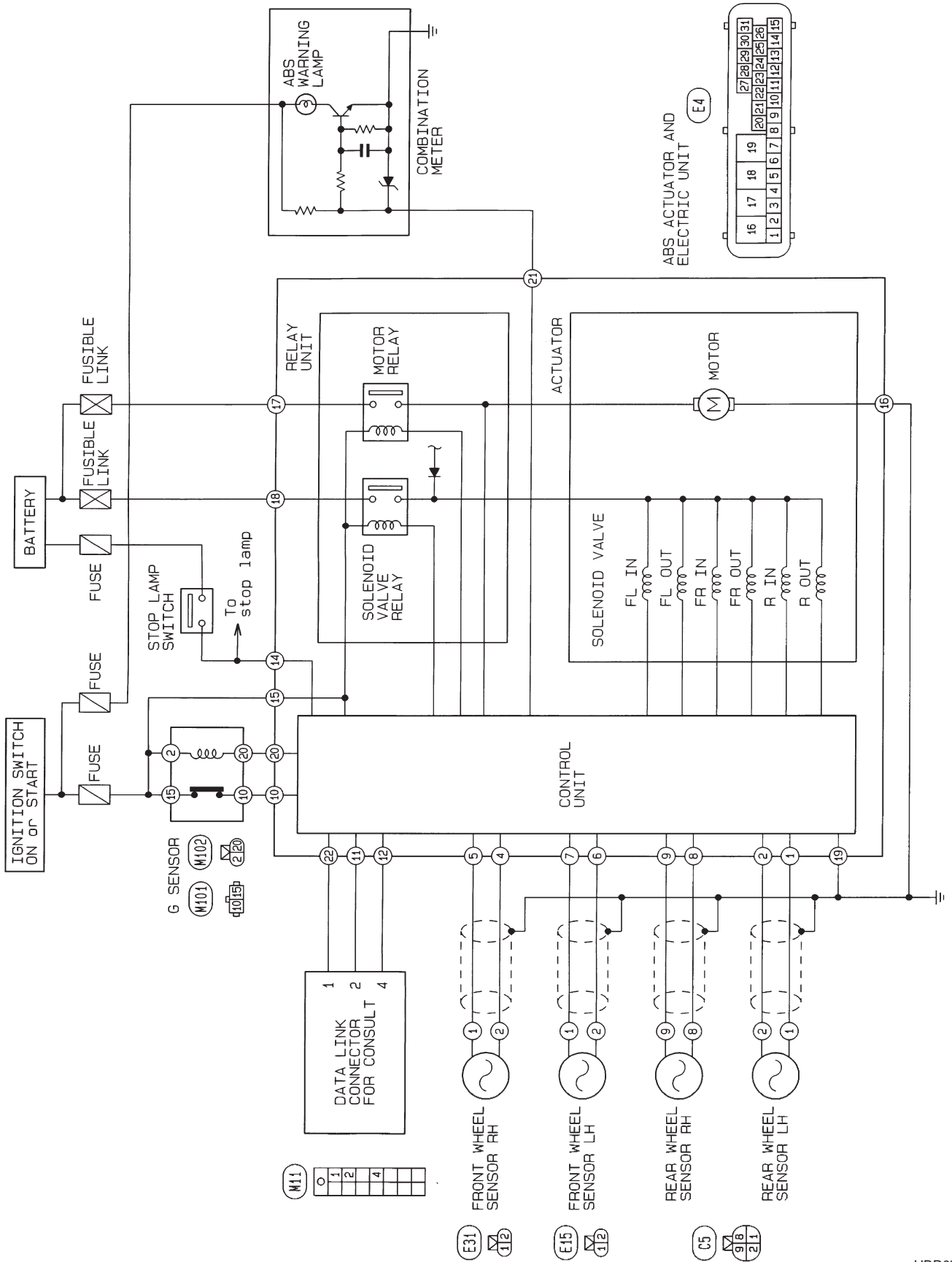

# TROUBLE DIAGNOSES

## Wiring Diagram — ABS —/4WD Models

BR-ABS-07

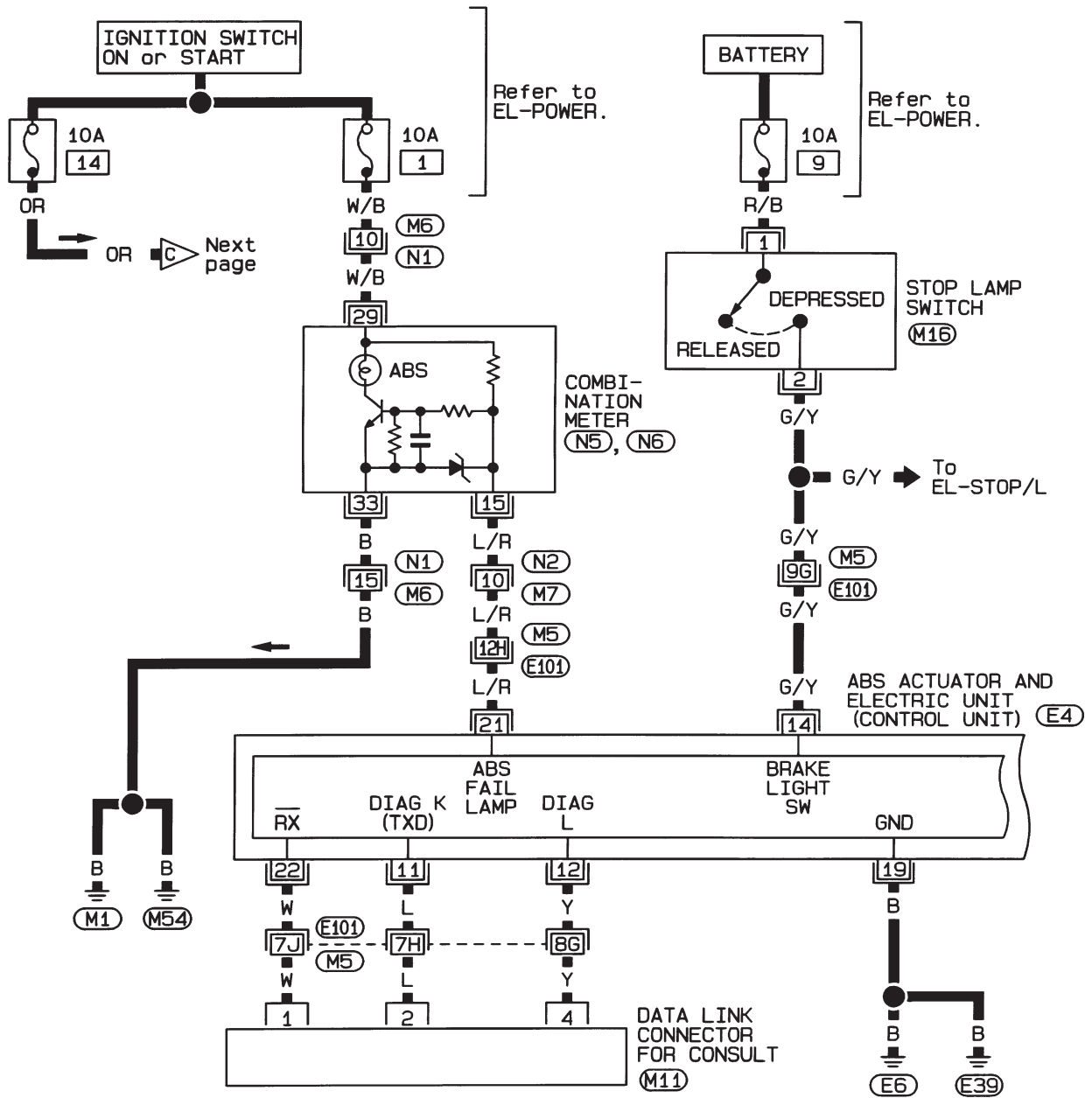

|   |   |   |    |    |    |    |    |       |
|---|---|---|----|----|----|----|----|-------|
| ○ | 1 | 2 | 3  | 4  | 5  | 6  | 7  | (M11) |
|   | 8 | 9 | 10 | 11 | 12 | 13 | 14 | GY    |

|  |   |   |       |
|--|---|---|-------|
|  | 1 | 2 | (M16) |
|  |   |   | B     |

|    |    |    |    |    |    |    |    |    |    |      |    |    |    |   |
|----|----|----|----|----|----|----|----|----|----|------|----|----|----|---|
| 1  | 2  | 3  | 4  | 5  | 6  | 7  | 8  | 9  | 10 | (N1) |    |    |    |   |
| 11 | 12 | 13 | 14 | 15 | 16 | 17 | 18 | 19 | 20 | 21   | 22 | 23 | 24 | W |

Refer to last page (Foldout page).

|   |    |    |    |    |    |    |    |      |    |    |    |   |
|---|----|----|----|----|----|----|----|------|----|----|----|---|
| 1 | 2  | 3  | 4  | 5  | 6  | 7  | 8  | (N2) |    |    |    |   |
| 9 | 10 | 11 | 12 | 13 | 14 | 15 | 16 | 17   | 18 | 19 | 20 | W |

|    |    |    |    |    |    |    |      |    |    |    |    |    |    |      |   |   |   |   |   |
|----|----|----|----|----|----|----|------|----|----|----|----|----|----|------|---|---|---|---|---|
| 26 | 25 | 24 | 23 | 22 | 21 | 20 | (N5) | 40 | 39 | 38 | 37 | 36 | 35 | (N6) |   |   |   |   |   |
| 19 | 18 | 17 | 16 | 15 | 14 | 13 | 12   | 11 | 10 | 9  | 8  | 7  | 6  | 5    | 4 | 3 | 2 | 1 | W |

(M5), (E101)

|    |    |    |    |    |    |    |    |    |      |    |    |    |    |    |   |
|----|----|----|----|----|----|----|----|----|------|----|----|----|----|----|---|
| 16 | 17 | 18 | 19 | 27 | 28 | 29 | 30 | 31 | (E4) |    |    |    |    |    |   |
| 1  | 2  | 3  | 4  | 5  | 6  | 7  | 8  | 9  | 10   | 11 | 12 | 13 | 14 | 15 | B |

# TROUBLE DIAGNOSES

## Wiring Diagram — ABS —/4WD Models (Cont'd)

BR-ABS-08

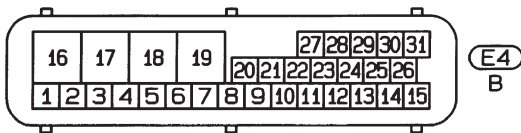
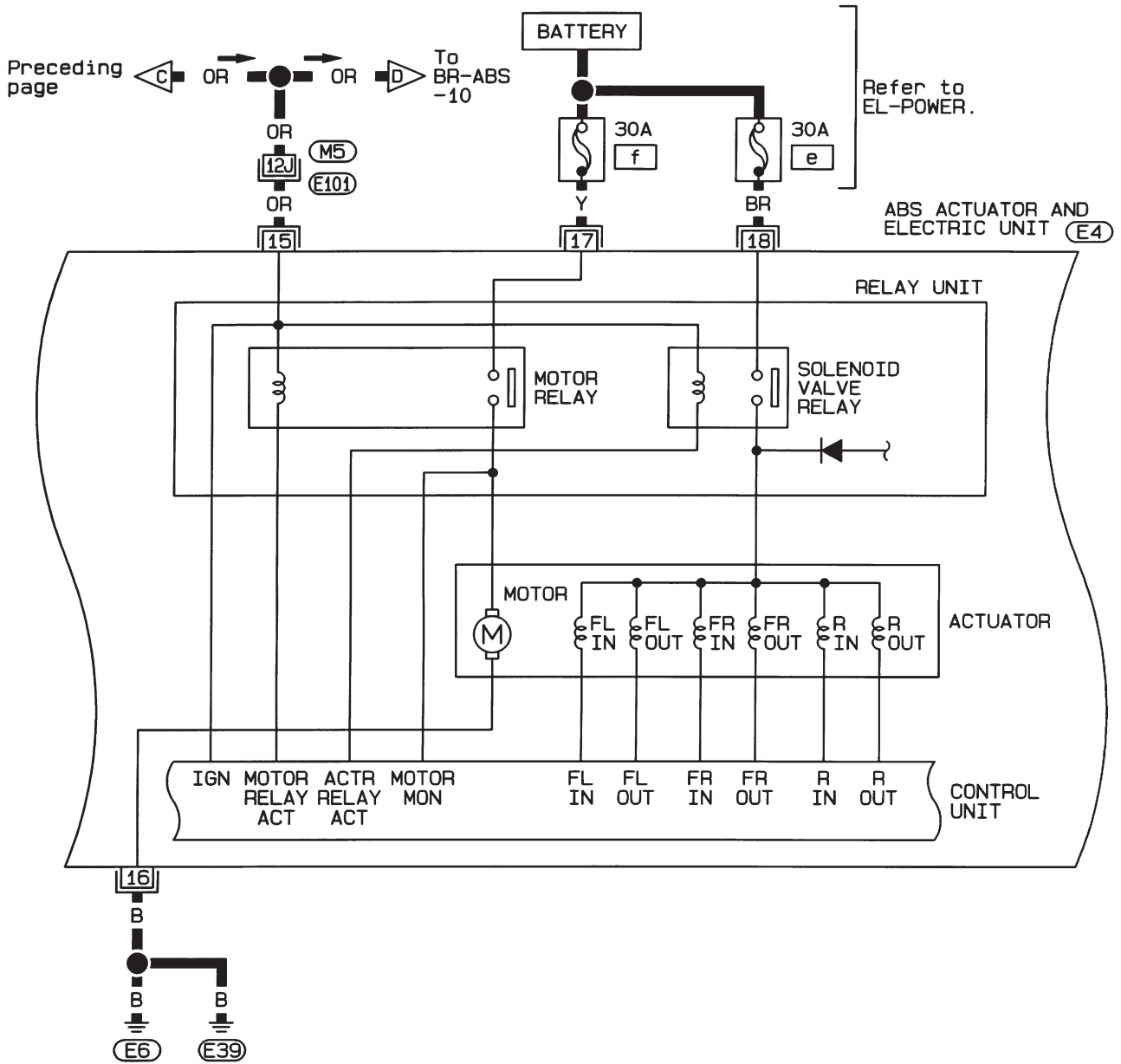

Refer to last page  
(Foldout page).

(M5), (E101)

# TROUBLE DIAGNOSES

## Wiring Diagram — ABS —/4WD Models (Cont'd)

BR-ABS-09

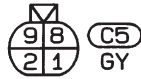
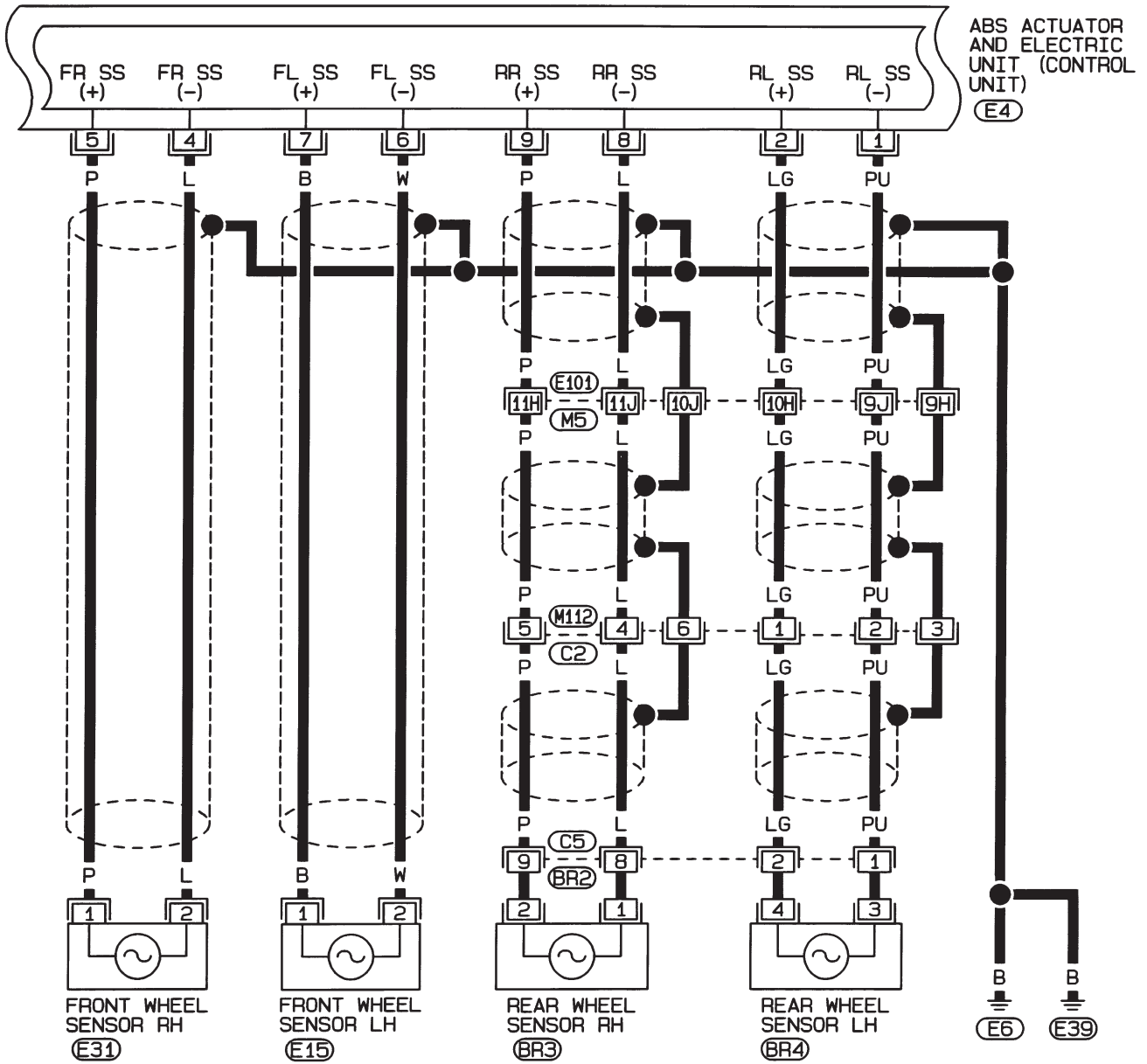

Refer to last page (Foldout page).

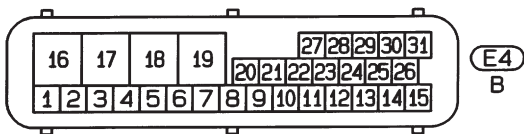

\* : This connector is not shown in "HARNESS LAYOUT", EL section.

# TROUBLE DIAGNOSES

## Wiring Diagram — ABS —/4WD Models (Cont'd)

BR-ABS-10

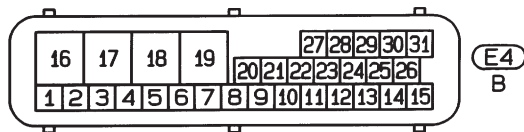
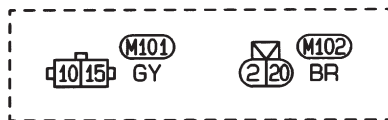
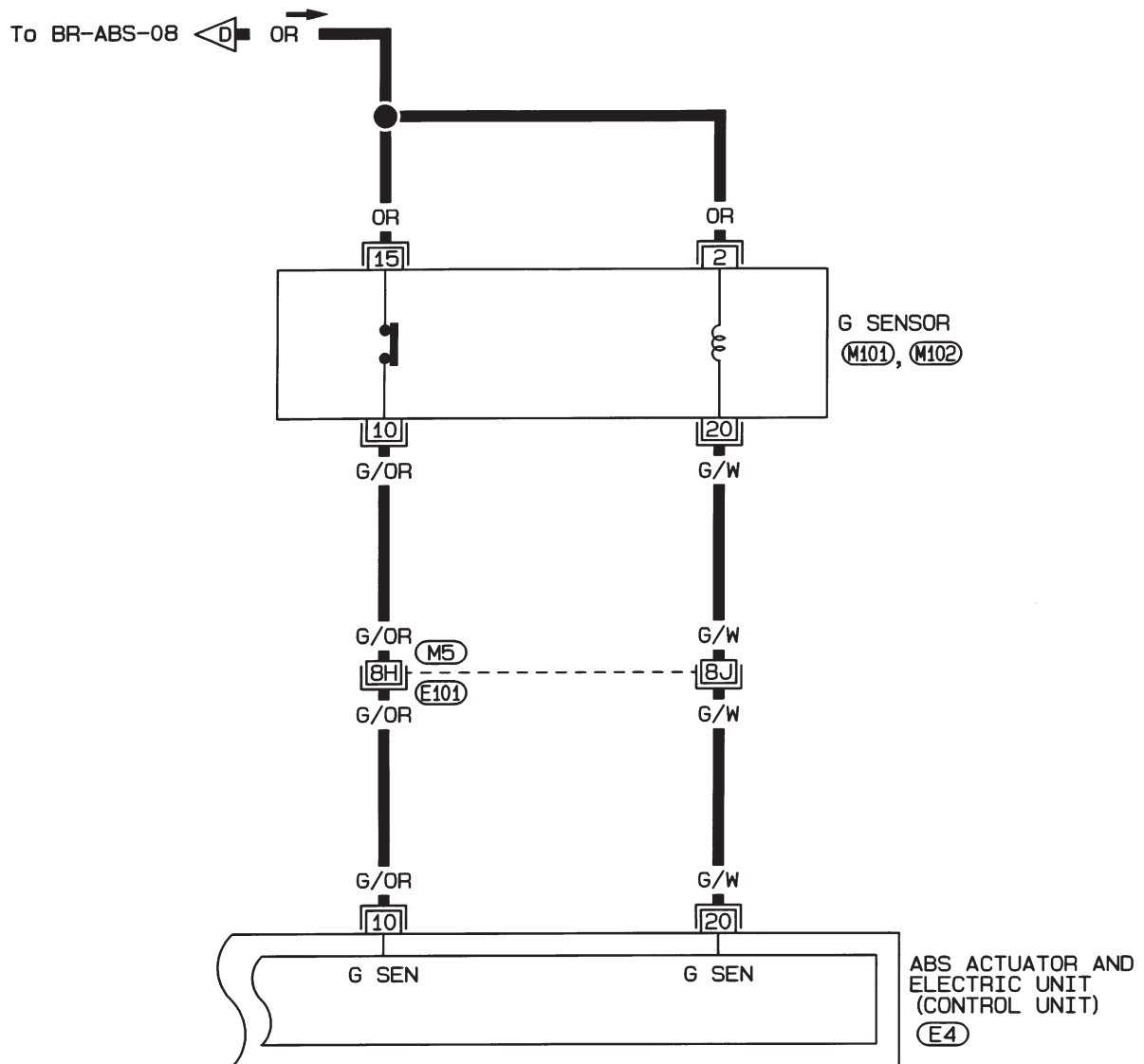

Refer to last page  
(Foldout page).

(M5), (E101)

# TROUBLE DIAGNOSES

## Self-diagnosis

### FUNCTION

- When a problem occurs in the ABS, the warning lamp on the instrument panel comes on. To start the self-diagnostic results mode, ground the self-diagnostic (check) terminal located on "Data Link Connector for CONSULT". The location of the malfunction is indicated by the warning lamp flashing.

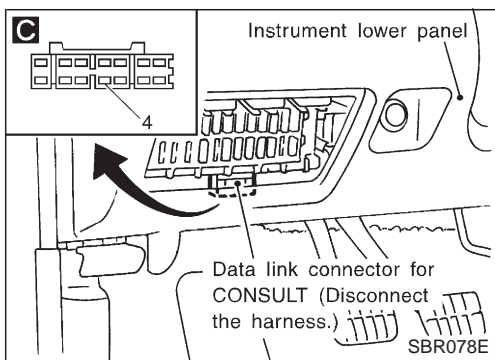
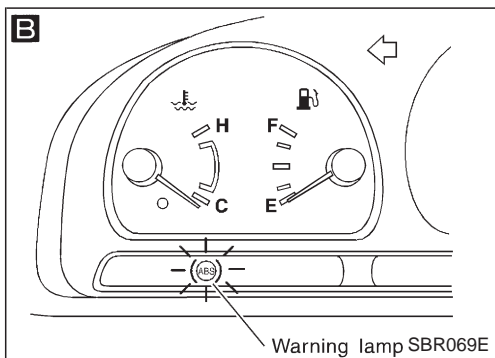
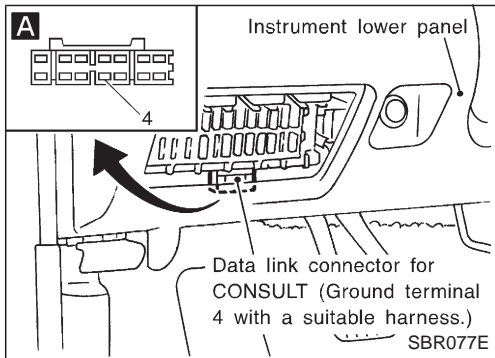

### SELF-DIAGNOSIS PROCEDURE

Drive vehicle over 30 km/h (19 MPH) for at least one minute.

Turn ignition switch "OFF".

**A** Ground terminal "4" of "Data link connector for CONSULT" with a suitable harness.

Turn ignition switch "ON" while grounding terminal "4".  
**Do not depress brake pedal.**

**B** After 3.0 seconds, the warning lamp starts flashing to indicate the malfunction code No. (See NOTE.)

Verify the location of the malfunction with the malfunction code chart. Refer to BR-55. Then make the necessary repairs following the diagnostic procedures.

After the malfunctions are repaired, erase the malfunction codes stored in the control unit. Refer to BR-54.

Rerun the self-diagnostic results mode to verify that the malfunction codes have been erased.

**C** Disconnect the check terminal from the ground. The self-diagnostic results mode is now complete.

**NOTE:** The indication terminates after five minutes. However, when the ignition switch is turned from "OFF" to "ON", the indication starts flashing again.

Ⓐ

# TROUBLE DIAGNOSES

## Self-diagnosis (Cont'd)

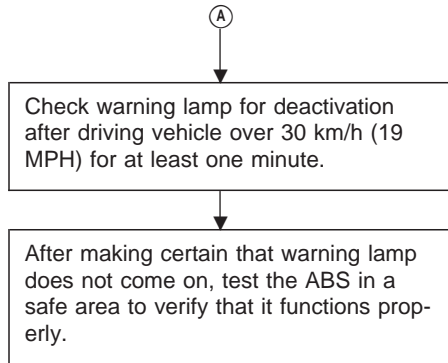

### HOW TO READ SELF-DIAGNOSTIC RESULTS (Malfunction codes)

- Determine the code No. by counting the number of times the warning lamp flashes on and off.
- When several malfunctions occur at one time, up to three code numbers can be stored; the latest malfunction will be indicated first.
- The indication begins with the start code 12. After that a maximum of three code numbers appear in the order of the latest one first. The indication then returns to the start code 12 to repeat (the indication will stay on for five minutes at the most).
- The malfunction code chart is given on the next page.

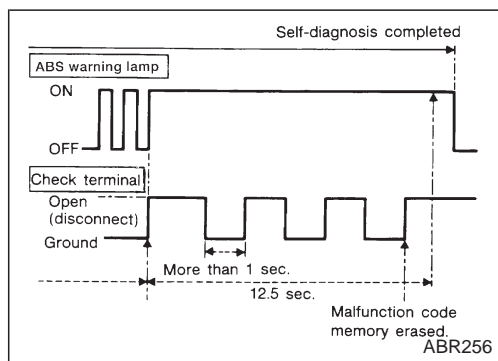
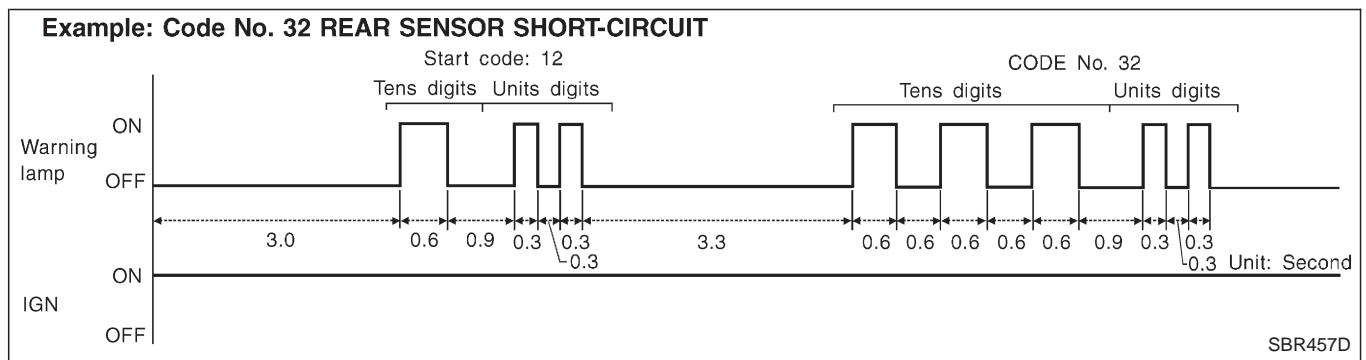

### HOW TO ERASE SELF-DIAGNOSTIC RESULTS (Malfunction codes)

1. Disconnect the check terminal from ground (ABS warning lamp will stay lit).
2. Within 12.5 seconds, ground the check terminal 3 times. Each terminal ground must last more than 1 second. The ABS warning lamp goes out after the erase operation has been completed.
3. Perform self-diagnosis again. Refer to BR-53. Only the start-code should appear, no malfunction codes.



## TROUBLE DIAGNOSES

### Self-diagnosis (Cont'd)

#### MALFUNCTION CODE/SYMPTOM CHART

| Code No.<br>(No. of warning lamp flashes)                       | Malfunctioning part  | Diagnostic procedure |
|---|--|----------------------|
| 45  | Actuator front left outlet solenoid valve  | 2                    |
| 46  | Actuator front left inlet solenoid valve   | 2                    |
| 41  | Actuator front right outlet solenoid valve   | 2                    |
| 42  | Actuator front right inlet solenoid valve  | 2                    |
| 55  | Actuator rear outlet solenoid valve  | 2                    |
| 56  | Actuator rear inlet solenoid valve   | 2                    |
| 25  | ★3 Front left sensor (open-circuit)  | 1                    |
| 26  | ★3 Front left sensor (short-circuit)   | 1                    |
| 21  | ★3 Front right sensor (open-circuit)   | 1                    |
| 22  | ★3 Front right sensor (short-circuit)  | 1                    |
| 35  | ★1, ★3 Rear sensor (open-circuit)  | 1                    |
| 36  | ★1, ★3 Rear sensor (short-circuit)   | 1                    |
| 31  | ★2, ★3 Rear right sensor (open-circuit)  | 1                    |
| 32  | ★2, ★3 Rear right sensor (short-circuit)   | 1                    |
| 35  | ★2, ★3 Rear left sensor (open-circuit)   | 1                    |
| 36  | ★2, ★3 Rear left sensor (short-circuit)  | 1                    |
| 18  | ★3 Sensor rotor  | 1                    |
| 17  | ★2 G sensor and circuit  | 5                    |
| 61  | ★5 Actuator motor or motor relay   | 3                    |
| 63  | Solenoid valve relay   | 2                    |
| 57  | ★4 Power supply (Low voltage)  | 4                    |
| 71  | Control unit   | 6                    |
| Warning lamp stays on when ignition switch is turned on         | Control unit power supply circuit<br>Warning lamp bulb circuit<br>Control unit or control unit connector<br>Solenoid valve relay stuck<br>Power supply for solenoid valve relay coil | 13                   |
| Warning lamp does not come on when ignition switch is turned on | Fuse, warning lamp bulb or warning lamp circuit<br>Control unit  | 12                   |
| Pedal vibration and noise                                       | —  | 11                   |
| Long stopping distance  | —  | 9                    |
| Unexpected pedal action   | —  | 8                    |
| ABS does not work   | —  | 10                   |
| ABS works frequently  | —  | 7                    |

★1: 2WD model only

★2: 4WD model only

★3: If one or more wheels spin on a rough or slippery road for 40 seconds or more, the ABS warning lamp will illuminate. This does not indicate a malfunction. Only in the case of the short-circuit (Code Nos. 26, 22, 32 and 36), after repair the ABS warning lamp also illuminates when the ignition switch is turned "ON". In this case, drive the vehicle at speeds greater than 30 km/h (19 MPH) for approximately 1 minute as specified in "SELF-DIAGNOSIS PROCEDURE", BR-53. Check to ensure that the ABS warning lamp goes out while the vehicle is being driven.

★4: The trouble code "57", which refers to a low power supply voltage, does not indicate that the ABS control unit is malfunctioning. Do not replace the ABS control unit with a new one.

★5: The trouble code "61" can sometimes appear when the ABS motor is not properly grounded. If it appears, be sure to check the condition of the ABS motor ground circuit connection.

# TROUBLE DIAGNOSES

## CONSULT

### CONSULT APPLICATION TO ABS

EE960 program card is not applicable to ABS. Use on board diagnostic system with ABS warning lamp until the next program card will be introduced. (Refer to "Self-diagnosis", BR-53.)

| ITEM   | SELF-DIAGNOSTIC RESULTS | DATA MONITOR | ACTIVE TEST |
|--|-------------------------|--------------|-------------|
| Front right wheel sensor   | X                       | X            | —           |
| Front left wheel sensor  | X                       | X            | —           |
| Rear wheel sensor ★1   | X                       | X            | —           |
| Rear right wheel sensor ★2   | X                       | X            | —           |
| Rear left wheel sensor ★2  | X                       | X            | —           |
| G switch (G sensor) ★2   | X                       | X            | X           |
| Stop lamp switch   | —                       | X            | —           |
| Front right inlet solenoid valve   | X                       | X            | X           |
| Front right outlet solenoid valve  | X                       | X            | X           |
| Front left inlet solenoid valve  | X                       | X            | X           |
| Front left outlet solenoid valve   | X                       | X            | X           |
| Rear inlet solenoid valve  | X                       | X            | X           |
| Rear outlet solenoid valve   | X                       | X            | X           |
| Actuator solenoid valve relay  | X                       | X            | —           |
| Actuator motor relay<br>(ABS MOTOR is shown on the Data Monitor screen.) | X                       | X            | X           |
| ABS warning lamp   | —                       | X            | —           |
| Battery voltage  | X                       | X            | —           |

X : Applicable

— : Not applicable

★1: 2WD model only

★2: 4WD model only

### ECU (ABS control unit) part number mode

Ignore the ECU part number displayed in the ECU PART NUMBER MODE. Refer to parts catalog to order the ECU.

# TROUBLE DIAGNOSES

## CONSULT Inspection Procedure SELF-DIAGNOSIS PROCEDURE

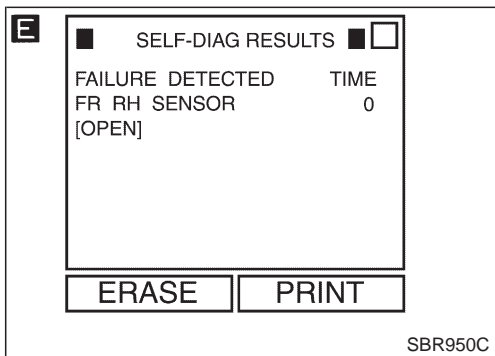
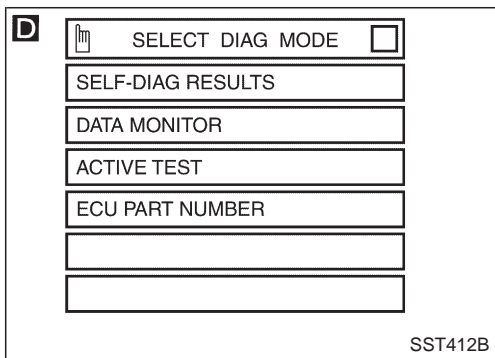
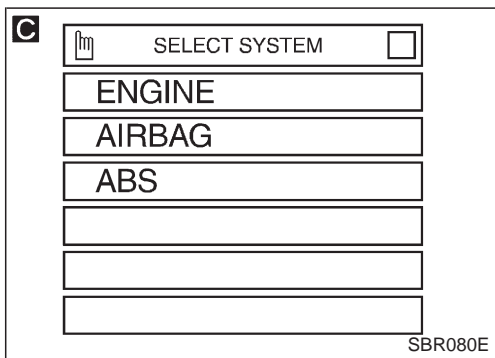
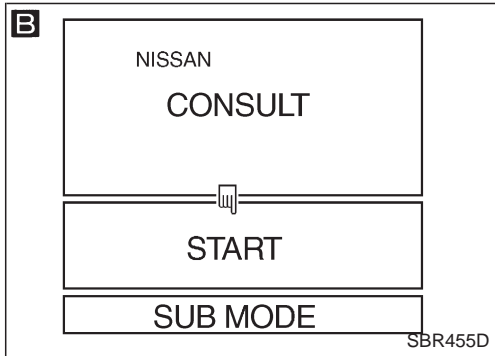
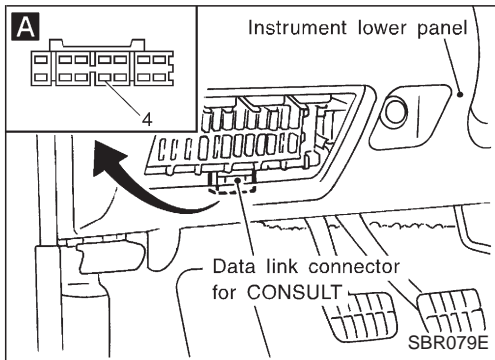

**A**

- 1) Turn ignition switch OFF.
- 2) Connect CONSULT to Data Link Connector for CONSULT.

1) Start engine.  
2) Drive vehicle over 30 km/h (19 MPH) for at least one minute.

**B** 1) Stop vehicle with engine running and touch "START" on CONSULT screen.  
**C** 2) Touch "ABS".  
**D** 3) Touch "SELF-DIAG RESULTS".  
• The screen shows the detected malfunction and how many times the ignition switch has been turned since the malfunction.

Make the necessary repairs following the diagnostic procedures.

**E** After the malfunctions are repaired, erase the self-diagnostic results stored in the control unit by touching "ERASE".

Check warning lamp for deactivation after driving vehicle over 30 km/h (19 MPH) for at least one minute.

Test the ABS in a safe area to verify that it functions properly.

**Note:** "SELF-DIAG RESULTS" screen shows the detected malfunction and how many times the ignition switch has been turned since the malfunction.

# TROUBLE DIAGNOSES

## CONSULT Inspection Procedure (Cont'd)

### SELF-DIAGNOSTIC RESULTS MODE

| Diagnostic item                 | Diagnostic item is detected when ...   | Diagnostic procedure |
|---------------------------------|--|----------------------|
| FR RH SENSOR [OPEN] ★1          | ● Circuit for front right wheel sensor is open.<br>(An abnormally high input voltage is entered.)  | 1                    |
| FR LH SENSOR [OPEN] ★1          | ● Circuit for front left wheel sensor is open.<br>(An abnormally high input voltage is entered.)   | 1                    |
| RR SENSOR [OPEN] ★1, ★2         | ● Circuit for rear sensor is open.<br>(An abnormal high input voltage is entered.)   | 1                    |
| RR RH SENSOR [OPEN] ★1, ★3      | ● Circuit for rear right sensor is open.<br>(An abnormally high input voltage is entered.)   | 1                    |
| RR LH SENSOR [OPEN] ★1, ★3      | ● Circuit for rear left sensor is open.<br>(An abnormally high input voltage is entered.)  | 1                    |
| FR RH SENSOR [SHORT] ★1         | ● Circuit for front right wheel sensor is shorted.<br>(An abnormally low input voltage is entered.)  | 1                    |
| FR LH SENSOR [SHORT] ★1         | ● Circuit for front left wheel sensor is shorted.<br>(An abnormally low input voltage is entered.)   | 1                    |
| RR SENSOR [SHORT] ★1, ★2        | ● Circuit for rear sensor is shorted.<br>(An abnormal low input voltage is entered.)   | 1                    |
| RR RH SENSOR [SHORT] ★1, ★3     | ● Circuit for rear right sensor is shorted.<br>(An abnormally low input voltage is entered.)   | 1                    |
| RR LH SENSOR [SHORT] ★1, ★3     | ● Circuit for rear left sensor is shorted.<br>(An abnormally low input voltage is entered.)  | 1                    |
| ABS SENSOR [ABNORMAL SIGNAL] ★1 | ● Teeth damage on sensor rotor or improper installation of wheel sensor.<br>(Abnormal wheel sensor signal is entered.)   | 1                    |
| FR RH IN ABS SOL [OPEN]         | ● Circuit for front right inlet solenoid valve is open.<br>(An abnormally low output voltage is entered.)  | 2                    |
| FR LH IN ABS SOL [OPEN]         | ● Circuit for front left inlet solenoid valve is open.<br>(An abnormally low output voltage is entered.)   | 2                    |
| RR IN ABS SOL [OPEN]            | ● Circuit for rear inlet solenoid valve is open.<br>(An abnormally low output voltage is entered.)   | 2                    |
| FR RH IN ABS SOL [SHORT]        | ● Circuit for front right inlet solenoid valve is shorted.<br>(An abnormally high output voltage is entered.)  | 2                    |
| FR LH IN ABS SOL [SHORT]        | ● Circuit for front left inlet solenoid valve is shorted.<br>(An abnormally high output voltage is entered.)   | 2                    |
| RR IN ABS SOL [SHORT]           | ● Circuit for rear inlet solenoid valve is shorted.<br>(An abnormally high output voltage is entered.)   | 2                    |
| FR RH OUT ABS SOL [OPEN]        | ● Circuit for front right outlet solenoid valve is open.<br>(An abnormally low output voltage is entered.)   | 2                    |
| FR LH OUT ABS SOL [OPEN]        | ● Circuit for front left outlet solenoid valve is open.<br>(An abnormally low output voltage is entered.)  | 2                    |
| RR OUT ABS SOL [OPEN]           | ● Circuit for rear outlet solenoid valve is open.<br>(An abnormally low output voltage is entered.)  | 2                    |
| FR RH OUT ABS SOL [SHORT]       | ● Circuit for front right outlet solenoid valve is shorted.<br>(An abnormally high output voltage is entered.)   | 2                    |
| FR LH OUT ABS SOL [SHORT]       | ● Circuit for front left outlet solenoid valve is shorted.<br>(An abnormally high output voltage is entered.)  | 2                    |
| RR OUT ABS SOL [SHORT]          | ● Circuit for rear outlet solenoid valve is shorted.<br>(An abnormally high output voltage is entered.)  | 2                    |
| ABS ACTUATOR RELAY [ABNORMAL]   | ● Actuator solenoid valve relay is ON, even if control unit sends off signal.<br>● Actuator solenoid valve relay is OFF, even if control unit sends on signal. | 2                    |
| ABS MOTOR RELAY [ABNORMAL]      | ● Circuit for ABS motor relay is open or shorted.<br>● Circuit for actuator motor is open or shorted.<br>● Actuator motor relay is stuck.                      | 3                    |
| BATTERY VOLT [VB-LOW]           | ● Power source voltage supplied to ABS control unit is abnormally low.   | 4                    |
| CONTROL UNIT                    | ● Function of calculation in ABS control unit has failed.  | 6                    |
| G-SENSOR [ABNORMAL] ★3          | ● G sensor circuit is open or shorted.   | 5                    |

★1: If one or more wheels spin on a rough or slippery road for 40 seconds or more, the ABS warning lamp will illuminate. This does not indicate a malfunction. Only in the case of the short-circuit (Code Nos. 26, 22, 32 and 36), after repair the ABS warning lamp also illuminates when the ignition switch is turned "ON". In this case, drive the vehicle at speeds greater than 30 km/h (19 MPH) for approximately 1 minute as specified in "SELF-DIAGNOSIS PROCEDURE", BR-53. Check to ensure that the ABS warning lamp goes out while the vehicle is being driven.

★2: 2WD model only

★3: 4WD model only

# TROUBLE DIAGNOSES

## CONSULT Inspection Procedure (Cont'd) DATA MONITOR PROCEDURE

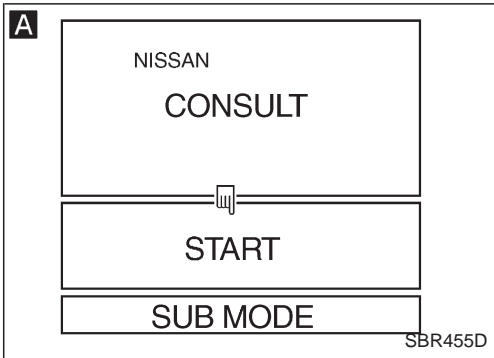

- 1) Turn ignition switch OFF.
- 2) Connect CONSULT to Data Link Connector for CONSULT.
- 3) Turn ignition switch ON.

- A** 1) Touch "START" on CONSULT screen.  
**B** 2) Touch "ABS".  
**C** 3) Touch "DATA MONITOR".

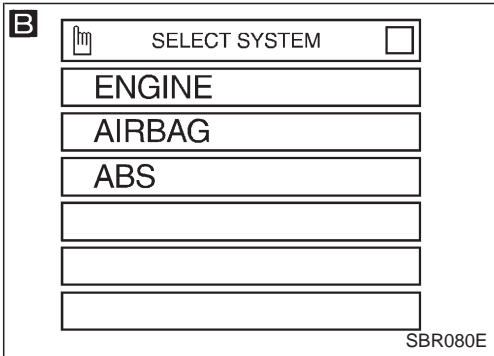

- D** 1) Touch "SETTING" on "SELECT MONITOR ITEM" screen.  
**E** 2) Touch "LONG TIME" on "SET RECORDING COND" screen.  
**D** 3) Touch "START" on "SELECT MONITOR ITEM".

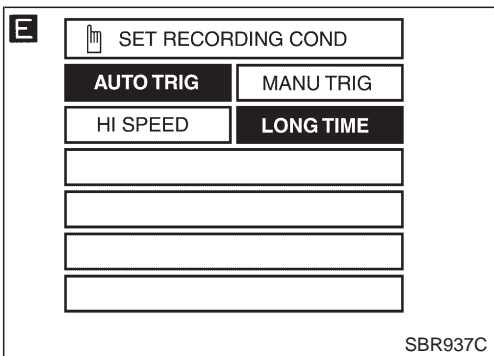
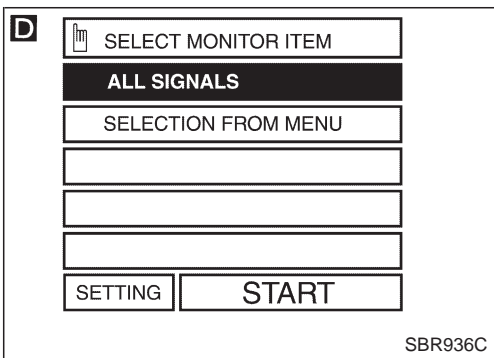
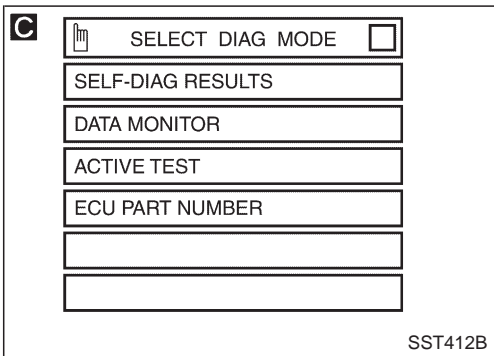

# TROUBLE DIAGNOSES

## CONSULT Inspection Procedure (Cont'd)

### ACTIVE TEST PROCEDURE

- When conducting Active test, vehicle must be stationary.
- When ABS warning lamp stays on, never conduct Active test.

- 1) Turn ignition switch OFF.
- 2) Connect CONSULT to Data Link Connector for CONSULT.
- 3) Start engine.

- 1) Touch "START" on CONSULT screen.
- 2) Touch "ABS".
- 3) Touch "ACTIVE TEST".

- 1) Select active test item by touching screen.
- 2) Touch "START".

Carry out the active test by touching screen key.

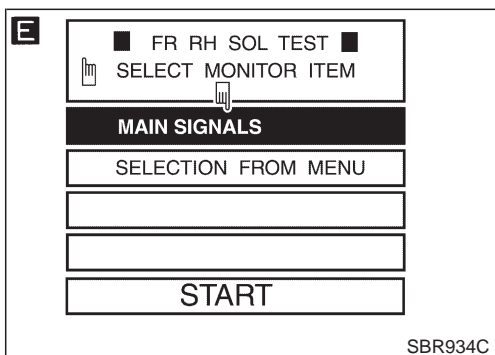
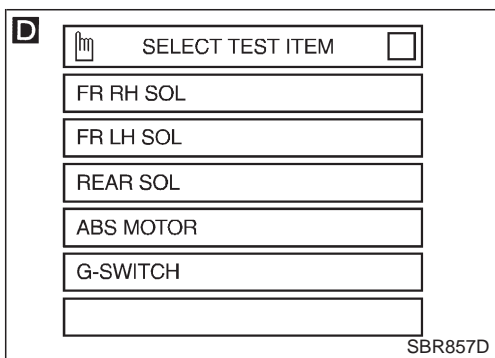
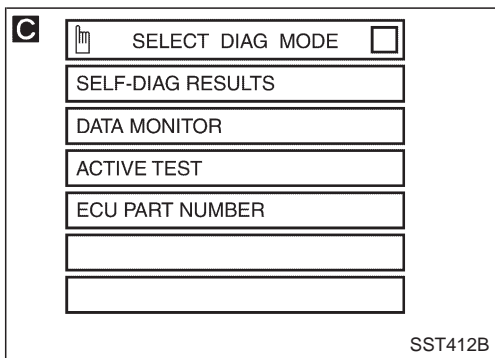
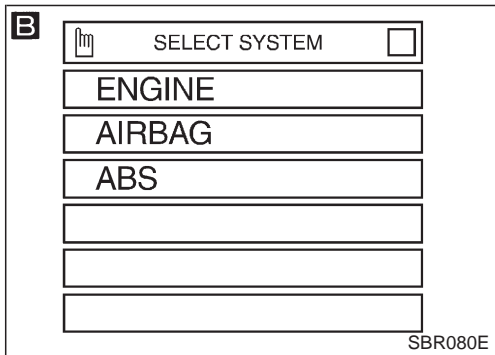
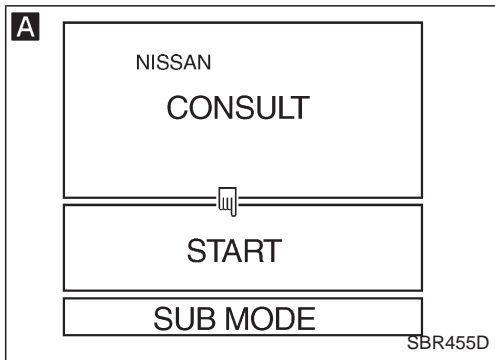

## TROUBLE DIAGNOSES

### CONSULT Inspection Procedure (Cont'd)

#### DATA MONITOR MODE

| MONITOR ITEM  | CONDITION  | SPECIFICATION   |
|---|--|---|
| FR RH SENSOR<br>FR LH SENSOR<br>RR SENSOR★1<br>RR RH SENSOR★2<br>RR LH SENSOR★2           | Drive vehicle.<br>(Each wheel is rotating.)  | Wheel speed signal<br>(Almost the same speed as speedometer.)   |
| STOP LAMP SW  | Brake is depressed.  | Depress the pedal: ON<br>Release the pedal: OFF   |
| G-SWITCH★2  | Vehicle is driven.<br>Vehicle is stopped.<br>Brake is applied.                                     | During sudden braking while driving on high $\mu$ roads (asphalt roads, etc.): OFF<br>While vehicle is stopped or during constant-speed driving: ON |
| FR RH IN SOL<br>FR RH OUT SOL<br>FR LH IN SOL<br>FR LH OUT SOL<br>RR IN SOL<br>RR OUT SOL | 1. Drive vehicle at speeds over 30 km/h (19 MPH) for at least one minute.<br>2. Engine is running. | Operating conditions for each solenoid valve are indicated.<br>ABS is not operating: OFF  |
| MOTOR RELAY   |  | ABS is not operating: OFF<br>ABS is operating: ON   |
| ACTUATOR RELAY  |  | Ignition switch ON (Engine stops): OFF<br>Engine running: ON  |
| WARNING LAMP  | Ignition switch is ON or engine is running.  | ABS warning lamp is turned on: ON<br>ABS warning lamp is turned off: OFF  |
| BATTERY VOLT  |  | Power supply voltage for control unit   |

★1: 2WD model only

★2: 4WD model only

#### ACTIVE TEST MODE

| TEST ITEM   | CONDITION              | JUDGEMENT   |         |        |         |                |     |     |              |    |     |                  |    |    |
|---|------------------------|---|---------|--------|---------|----------------|-----|-----|--------------|----|-----|------------------|----|----|
| FR RH SOLENOID<br>FR LH SOLENOID<br>REAR SOLENOID | Engine is running.     | Brake fluid pressure control operation<br><br><table style="margin-left: auto; margin-right: auto;"> <tr> <td></td> <td style="text-align: center;">IN SOL</td> <td style="text-align: center;">OUT SOL</td> </tr> <tr> <td>UP (Increase):</td> <td style="text-align: center;">OFF</td> <td style="text-align: center;">OFF</td> </tr> <tr> <td>KEEP (Hold):</td> <td style="text-align: center;">ON</td> <td style="text-align: center;">OFF</td> </tr> <tr> <td>DOWN (Decrease):</td> <td style="text-align: center;">ON</td> <td style="text-align: center;">ON</td> </tr> </table> |         | IN SOL | OUT SOL | UP (Increase): | OFF | OFF | KEEP (Hold): | ON | OFF | DOWN (Decrease): | ON | ON |
|   |                        | IN SOL  | OUT SOL |        |         |                |     |     |              |    |     |                  |    |    |
| UP (Increase):                                    | OFF                    | OFF   |         |        |         |                |     |     |              |    |     |                  |    |    |
| KEEP (Hold):                                      | ON                     | OFF   |         |        |         |                |     |     |              |    |     |                  |    |    |
| DOWN (Decrease):                                  | ON                     | ON  |         |        |         |                |     |     |              |    |     |                  |    |    |
| ABS MOTOR   |                        | ABS actuator motor<br>ON: Motor runs (ABS motor relay ON)<br>OFF: Motor stops (ABS motor relay OFF)   |         |        |         |                |     |     |              |    |     |                  |    |    |
| G SWITCH★   | Ignition switch is ON. | G SWITCH (G SENSOR),<br>ON: Set G SWITCH MONITOR "ON"<br>(G switch circuit is closed.)<br>OFF: Set G SWITCH MONITOR "OFF"<br>(G switch circuit is open.)  |         |        |         |                |     |     |              |    |     |                  |    |    |

★: 4WD model only

**Note: Active test will automatically stop ten seconds after the test starts. (LIMIT SIGNAL monitor shows ON.)**

## TROUBLE DIAGNOSES

---

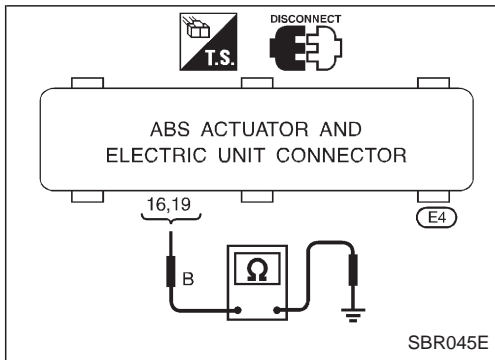

### Ground Circuit Check

#### ABS ACTUATOR AND ELECTRIC UNIT GROUND

- Check resistance between ABS actuator and electric unit connector terminals and ground.

**Resistance: approximately  $0\Omega$**



# TROUBLE DIAGNOSES FOR SELF-DIAGNOSTIC ITEMS

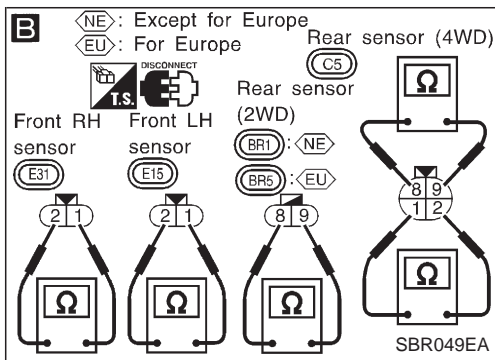
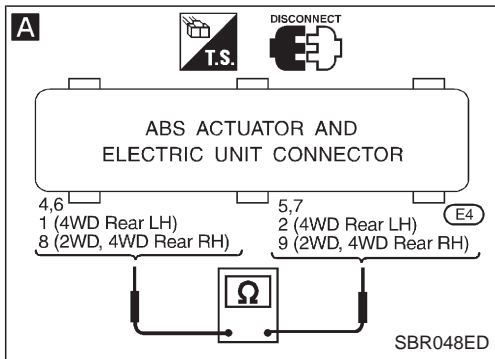
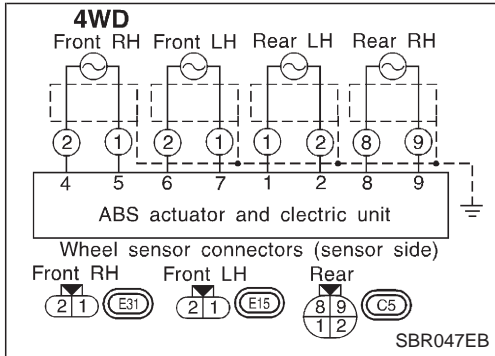
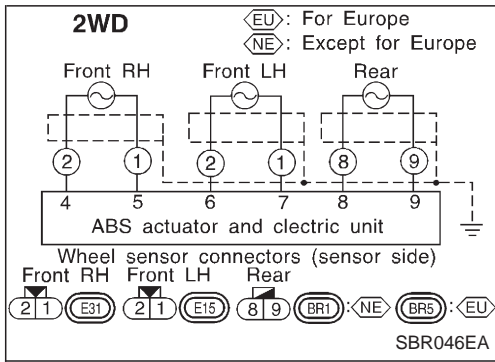

## Diagnostic Procedure 1 (Wheel sensor or rotor)

Malfunction code No. 21, 22, 25, 26, 31, 32, 35, 36 or 18

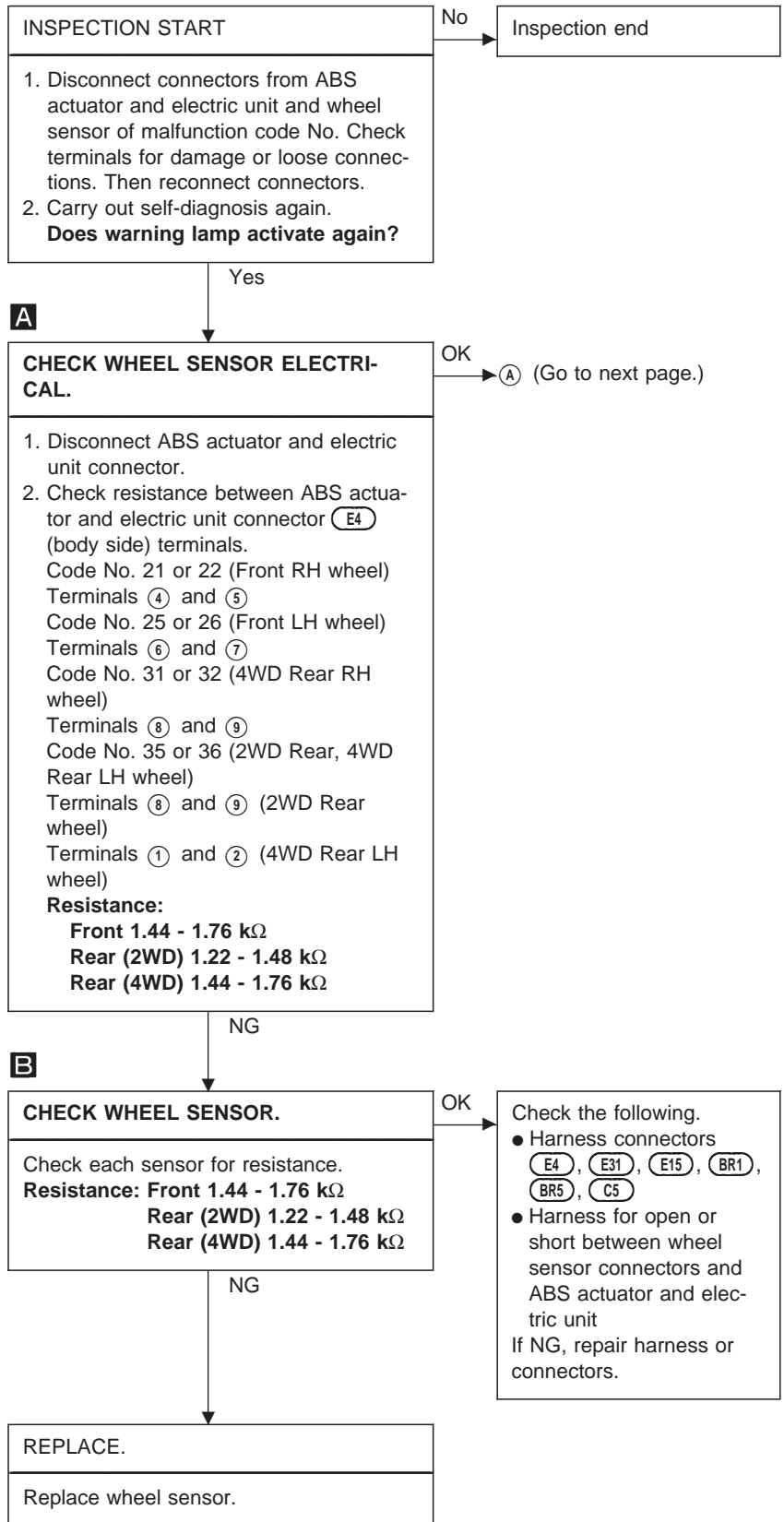

# TROUBLE DIAGNOSES FOR SELF-DIAGNOSTIC ITEMS

## Diagnostic Procedure 1 (Wheel sensor or rotor) (Cont'd)

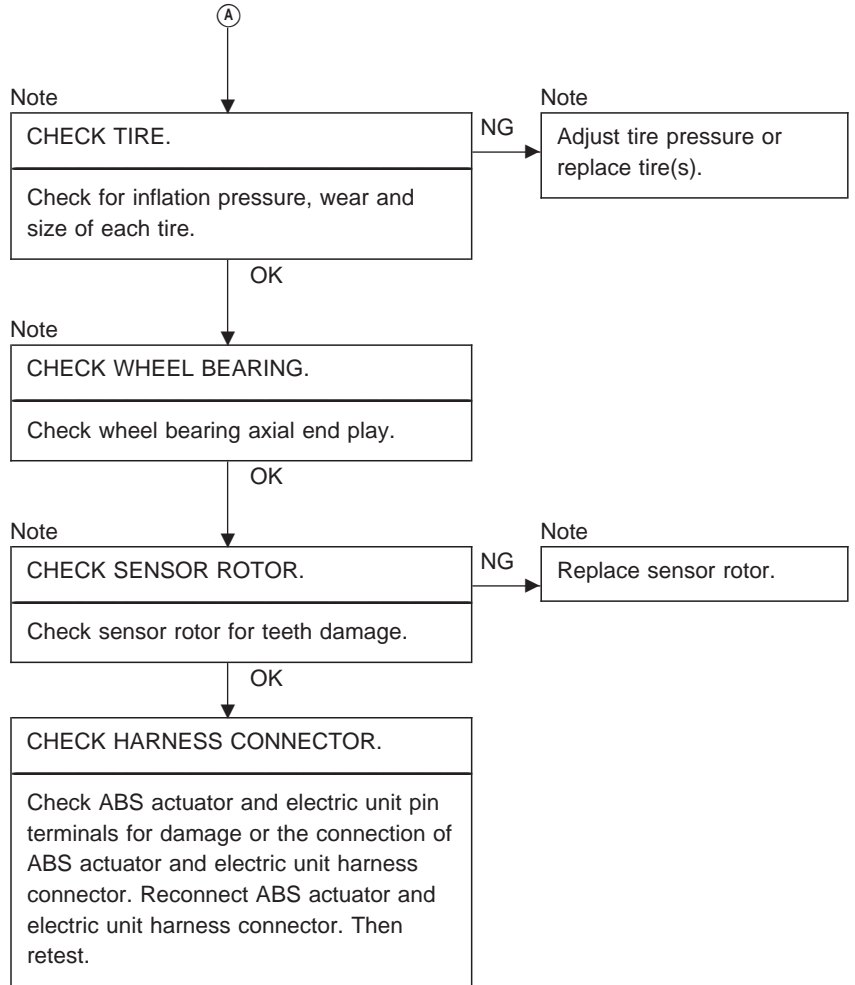

# TROUBLE DIAGNOSES FOR SELF-DIAGNOSTIC ITEMS

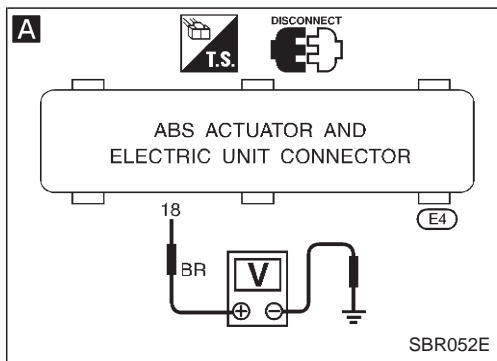
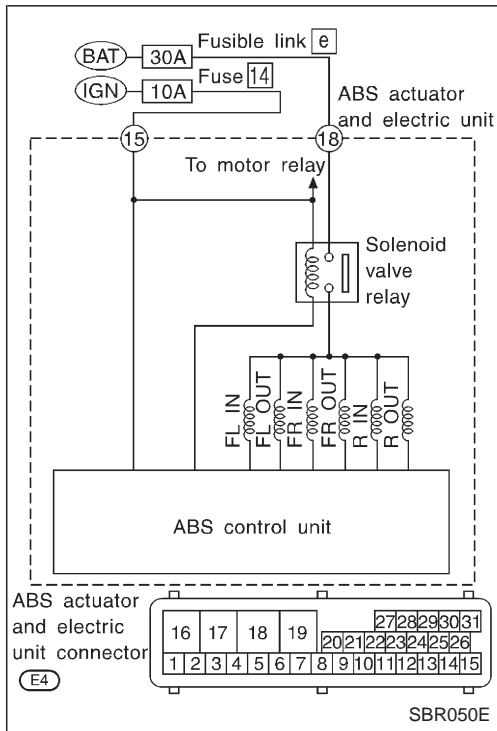

## Diagnostic Procedure 2 (ABS actuator solenoid valve and solenoid valve relay) Malfunction code No. 41, 45, 55, 42, 46, 56, 63

**CHECK FUSIBLE LINK.**

Check 30A fusible link [e]. For fusible link layout, refer to POWER SUPPLY ROUTING in EL section.

NG → (A) (Go to next page.)

OK ↓

**CHECK FUSE.**

Check 10A fuse [14]. For fuse layout, refer to POWER SUPPLY ROUTING in EL section.

NG → (B) (Go to next page.)

OK ↓

**CHECK CONNECTOR.**

1. Disconnect ABS actuator and electric unit connector. Check terminals for damage or loose connection. Then reconnect connector.  
2. Carry out self-diagnosis again.  
**Does warning lamp activate again?**

No → Inspection end

Yes ↓

**CHECK ABS ACTUATOR AND ELECTRIC UNIT GROUND CIRCUIT.**

Refer to ABS ACTUATOR AND ELECTRIC UNIT GROUND in Ground Circuit Check, BR-62.

NG → Repair harness and connector.

OK ↓

**CHECK SOLENOID VALVE RELAY POWER SUPPLY CIRCUIT.**

1. Disconnect ABS actuator and electric unit connector.  
2. Check voltage between ABS actuator and electric unit connector (E4) (body side) terminal (18) and ground.  
**Battery voltage should exist.**

NG → Check the following.  
● Harness connector (E4)  
● Harness for open or short between ABS actuator and electric unit and fusible link  
If NG, repair harness or connector.

OK ↓

**REPLACE.**

Replace ABS actuator and electric unit.

# TROUBLE DIAGNOSES FOR SELF-DIAGNOSTIC ITEMS

## Diagnostic Procedure 2 (ABS actuator solenoid valve and solenoid valve relay) (Cont'd)

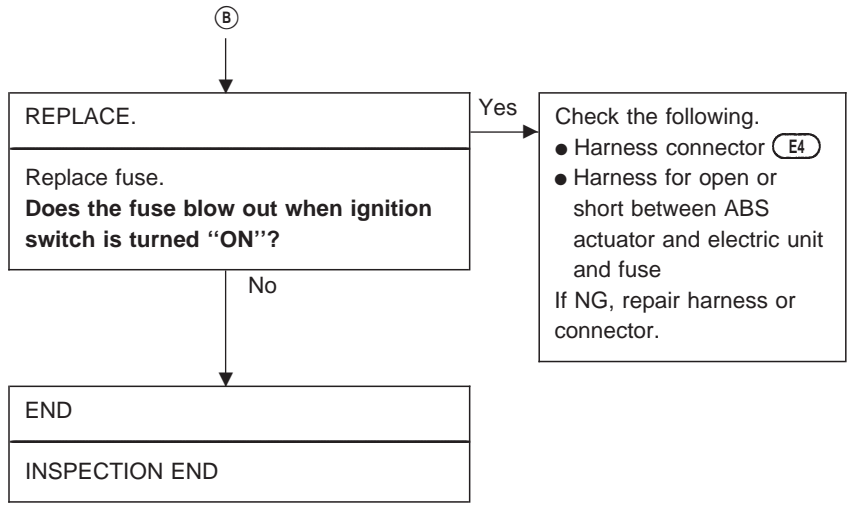
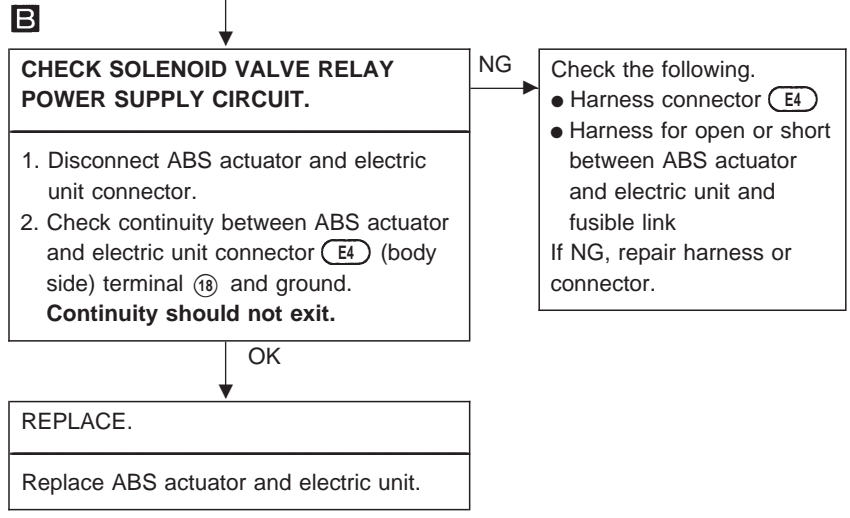
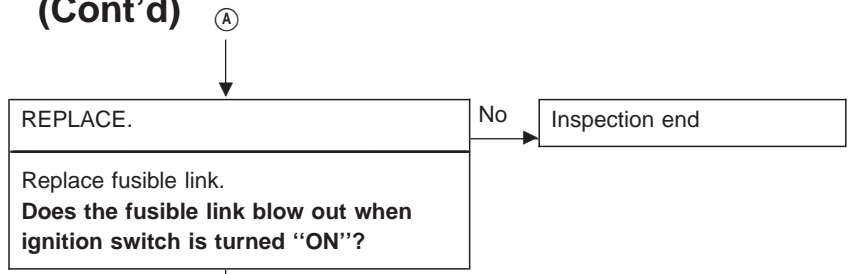
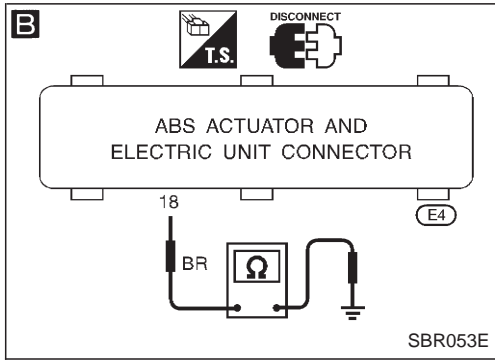

# TROUBLE DIAGNOSES FOR SELF-DIAGNOSTIC ITEMS

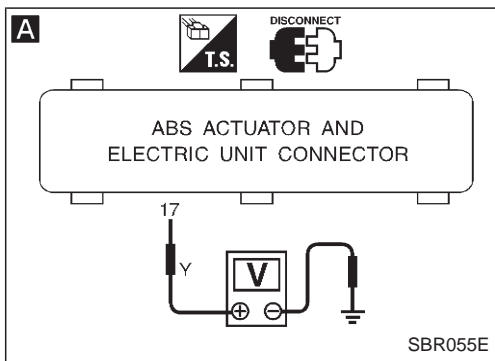
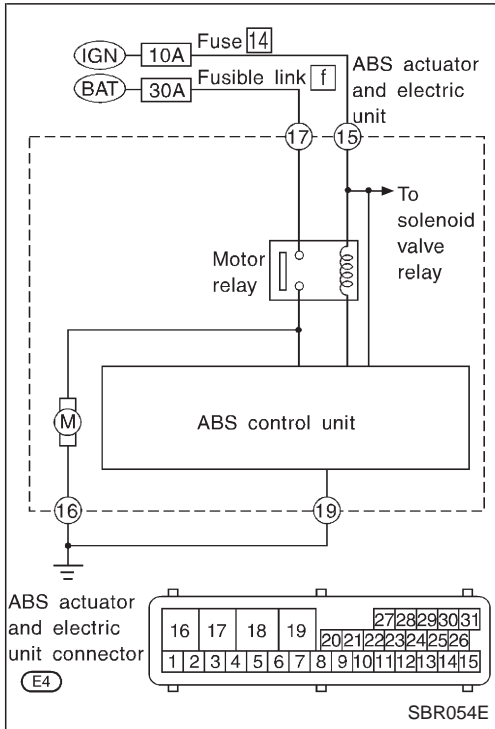

## Diagnostic Procedure 3 (Motor relay or motor)

### Malfunction code No. 61

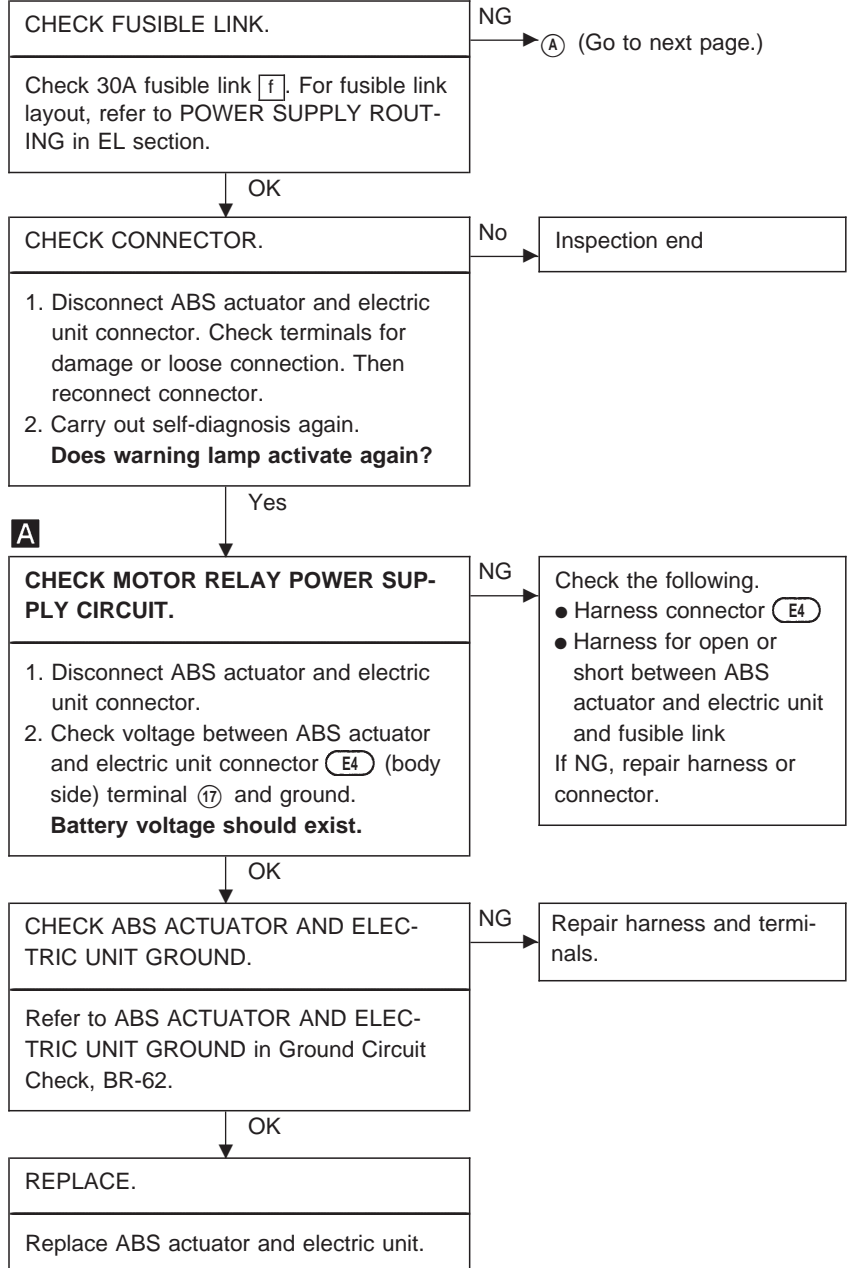

# TROUBLE DIAGNOSES FOR SELF-DIAGNOSTIC ITEMS

## Diagnostic Procedure 3 (Motor relay or motor) (Cont'd)

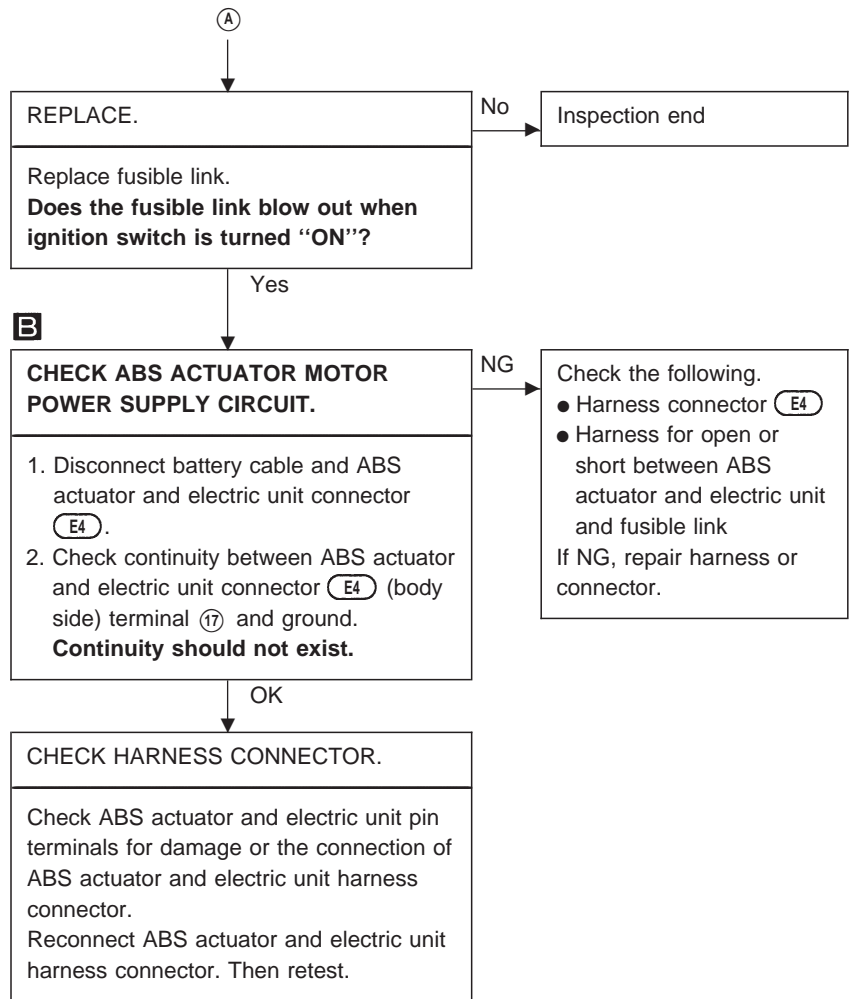
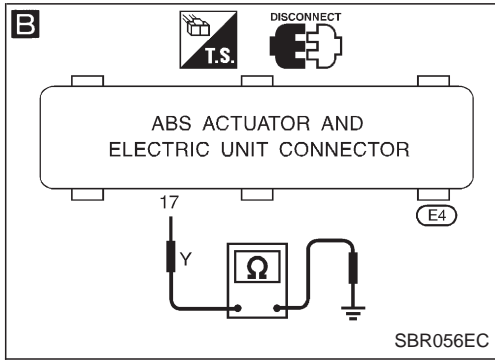

# TROUBLE DIAGNOSES FOR SELF-DIAGNOSTIC ITEMS

## Diagnostic Procedure 4 (Low voltage)

### Malfunction code No. 57

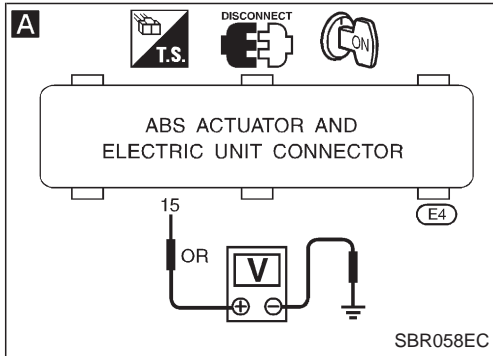
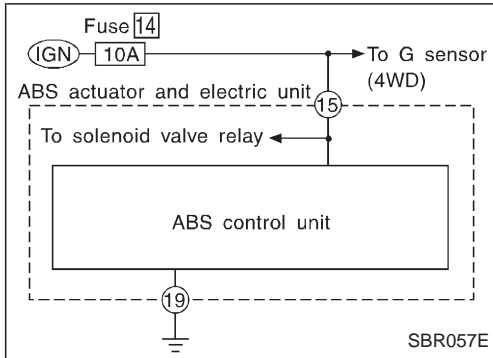

**CHECK CONNECTOR.**

No → Inspection end

1. Disconnect ABS actuator and electric unit connector. Check terminals for damage or loose connection. Then reconnect connector.  
2. Carry out self-diagnosis again.  
**Does warning lamp activate again?**

**A** Yes

**CHECK ABS CONTROL UNIT POWER SUPPLY CIRCUIT.**

NG → **A** (See below.)

1. Disconnect ABS actuator and electric unit connector.  
2. Check voltage between ABS actuator and electric unit connector (E4) (body side) terminal 15 and ground.  
**Battery voltage should exist when ignition switch is turned ON.**

OK

**CHECK ABS CONTROL UNIT GROUND.**

NG → Repair harness and connector.

Refer to ABS ACTUATOR AND ELECTRIC UNIT GROUND in Ground Circuit Check, BR-62.

OK

**CHECK HARNESS CONNECTOR.**

Check ABS actuator and electric unit pin terminals for damage or the connection of ABS actuator and electric unit harness connector. Reconnect ABS actuator and electric unit harness connector. Then retest.

**A**

**CHECK FUSE.**

NG → Replace fuse.

Check 10A fuse 14. For fuse layout, refer to POWER SUPPLY ROUTING in EL section.

OK

**CHECK ABS CONTROL UNIT POWER SUPPLY CIRCUIT.**

NG → Check the following.  
● Harness connector (E4)  
● Harness for open or short between ABS actuator and electric unit and fuse  
If NG, repair harness or connector.

Check continuity between battery and ABS actuator and electric unit connector (E4) (body side) terminal 15.

OK

**CHECK BATTERY.**

Check battery. Refer to BATTERY in EL section.

# TROUBLE DIAGNOSES FOR SELF-DIAGNOSTIC ITEMS

## Diagnostic Procedure 5 (G sensor)

### Malfunction code No. 17

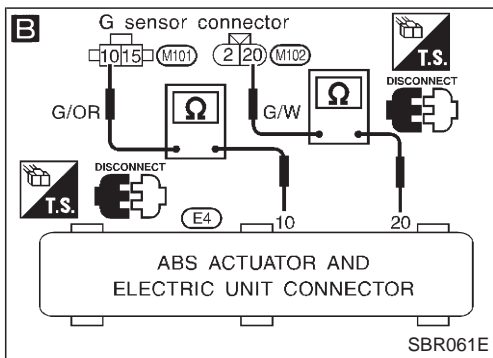
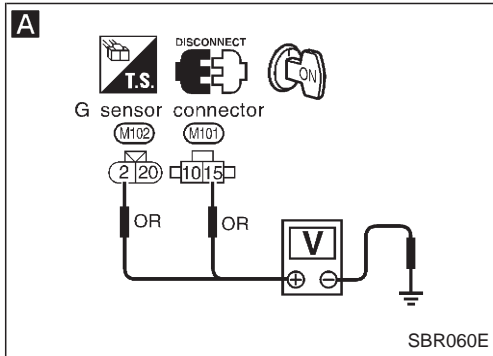
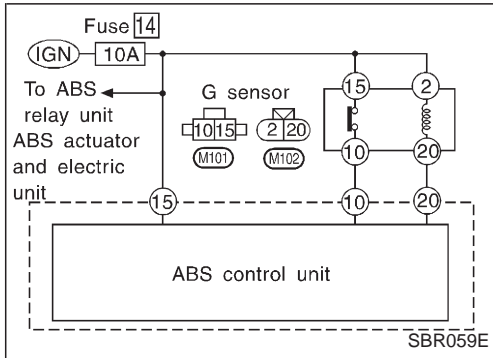

**CHECK G SENSOR POWER SUPPLY CIRCUIT.**

Check 10A fuse [14]. For fuse layout, refer to POWER SUPPLY ROUTING in EL section.

NG → Replace fuse.

OK

**CHECK CONNECTOR.**

1. Disconnect ABS actuator and electric unit connector. Check terminals for damage or loose connection. Then reconnect connector.  
2. Carry out self-diagnosis again.  
**Does warning lamp activate again?**

No → Inspection end

Yes

**CHECK G SENSOR.**

Refer to G SENSOR in Electrical Components Inspection, BR-71.

NG → Replace G sensor.

OK

**A**

**CHECK G SENSOR POWER SUPPLY CIRCUIT.**

1. Disconnect G sensor connector.  
2. Check voltage between G sensor connector (M101, M102) (body side) terminal ②, ⑩ and ground.  
**Battery voltage should exist.**

NG → Check the following.

- Harness connectors (M101, M102, E4)
- Harness for open or short between G sensor and ABS actuator and electric unit

If NG, repair harness or connectors.

OK

**B**

**CHECK G SENSOR GROUND.**

1. Disconnect ABS actuator and electric unit connector and G sensor connectors.  
2. Check continuity between ABS actuator and electric unit connector (E4) (body side) terminals ⑩, ⑳ and G sensor connectors (M101, M102) (body side) terminals ⑩, ⑳.  
**Continuity should exist.**

NG → Check the following.

- Harness connectors (M101, M102, E4)
- Harness for open or short between G sensor and ABS actuator and electric unit

If NG, repair harness or connectors.

OK

**CHECK HARNESS CONNECTOR.**

Check ABS actuator and electric unit pin terminals for damage or the connection of ABS actuator and electric unit harness connector. Reconnect ABS actuator and electric unit harness connector. Then retest.



# TROUBLE DIAGNOSES FOR SELF-DIAGNOSTIC ITEMS

## Diagnostic Procedure 5 (G sensor) (Cont'd) ELECTRICAL COMPONENTS INSPECTION

### G sensor

#### CAUTION:

The G sensor is easily damaged if it sustains an impact. Be careful not to drop or bump it.

1. Measure resistance between terminals ⑩ and ⑮ of G sensor unit connector.

| G sensor condition        | Resistance between terminals ⑩ and ⑮ | G sensor switch condition |
|---------------------------|--------------------------------------|---------------------------|
| Installed in vehicle      | 1.4 - 1.6 kΩ                         | "ON"                      |
| Tilted as shown in figure | 4.7 - 5.5 kΩ                         | "OFF"                     |

2. Measure resistance between terminals ② and ⑳ of the G sensor unit connector.

|             |            |
|-------------|------------|
| Resistance: | 70 - 124 Ω |
|-------------|------------|

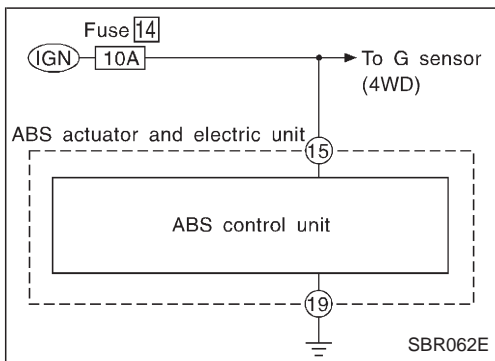
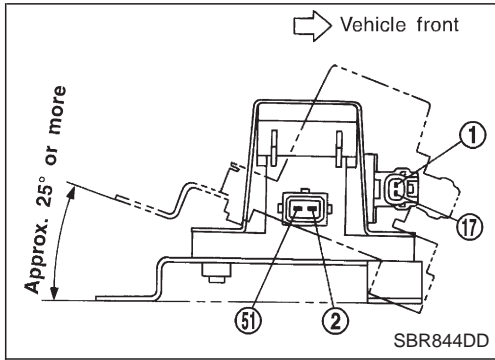

## Diagnostic Procedure 6 (Control unit)

### Malfunction code No. 71

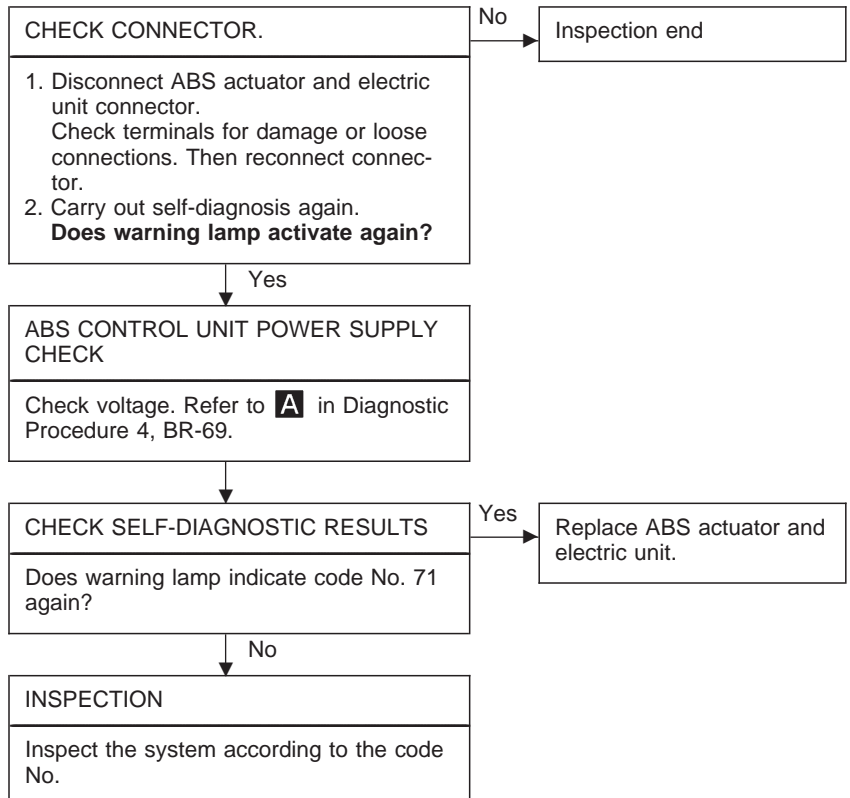

# TROUBLE DIAGNOSES FOR SYMPTOMS

## Diagnostic Procedure 7 (ABS works frequently.)

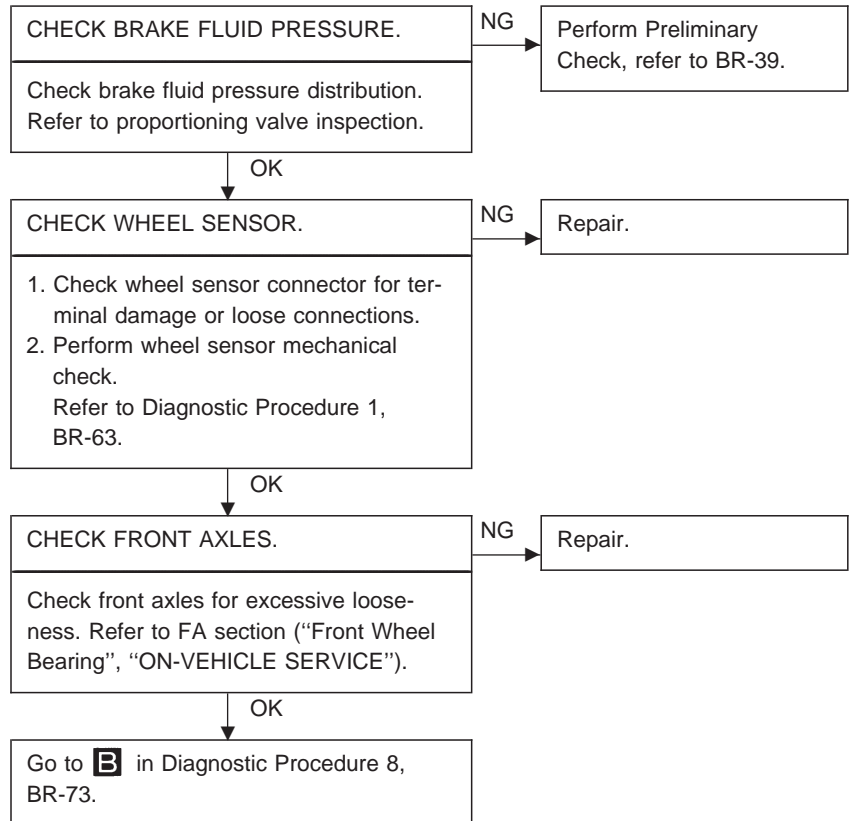

# TROUBLE DIAGNOSES FOR SYMPTOMS

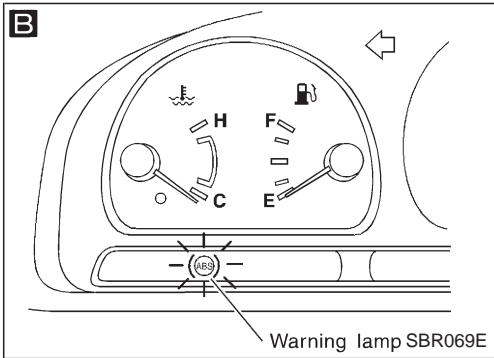
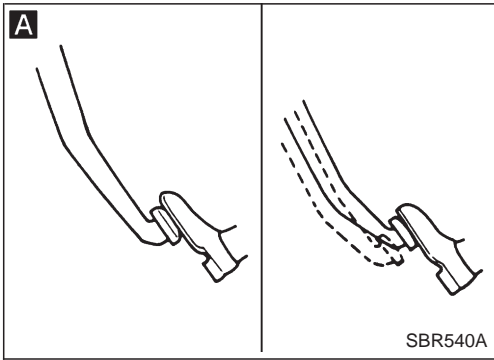

## Diagnostic Procedure 8 (Unexpected pedal action)

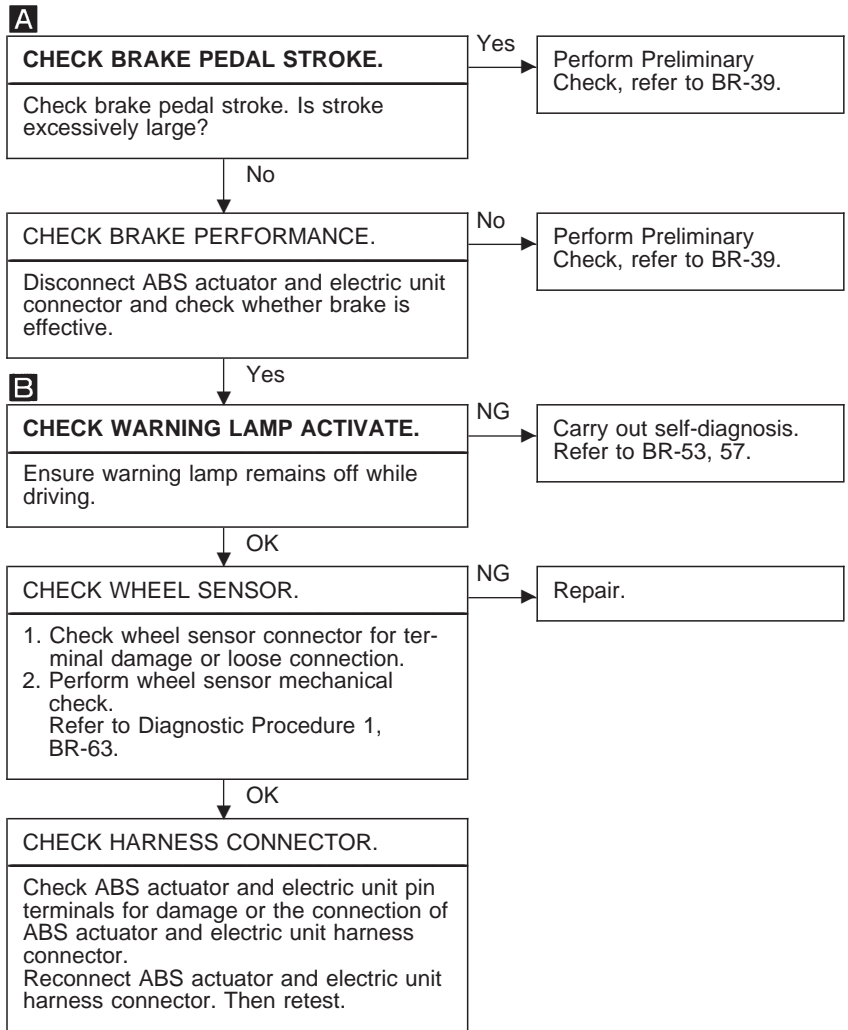

## Diagnostic Procedure 9 (Long stopping distance)

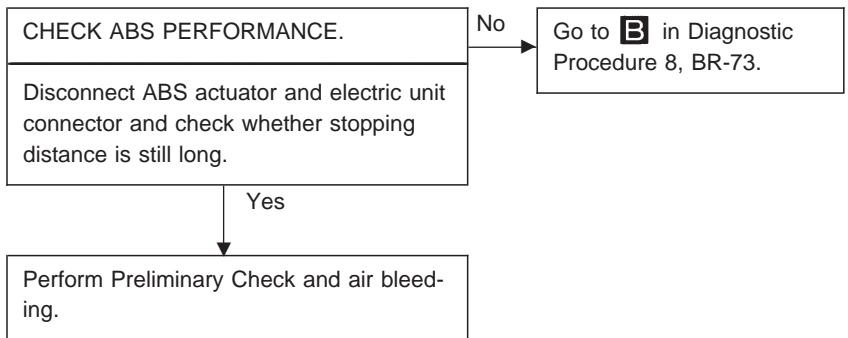

**Note:** Stopping distance may be larger than vehicles without ABS when road condition is slippery.

# TROUBLE DIAGNOSES FOR SYMPTOMS

## Diagnostic Procedure 10 (ABS does not work.)

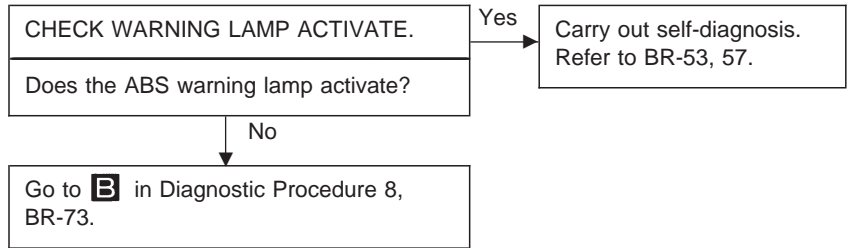

**Note: ABS does not work when vehicle speed is under 10 km/h (6 MPH).**

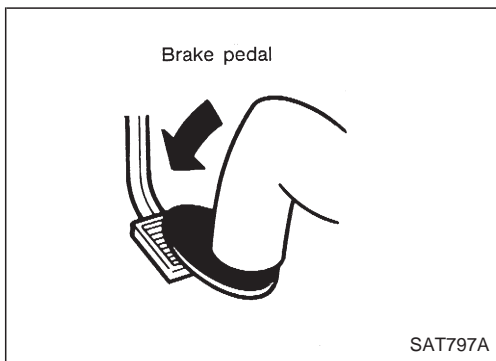

## Diagnostic Procedure 11 (Pedal vibration and noise)

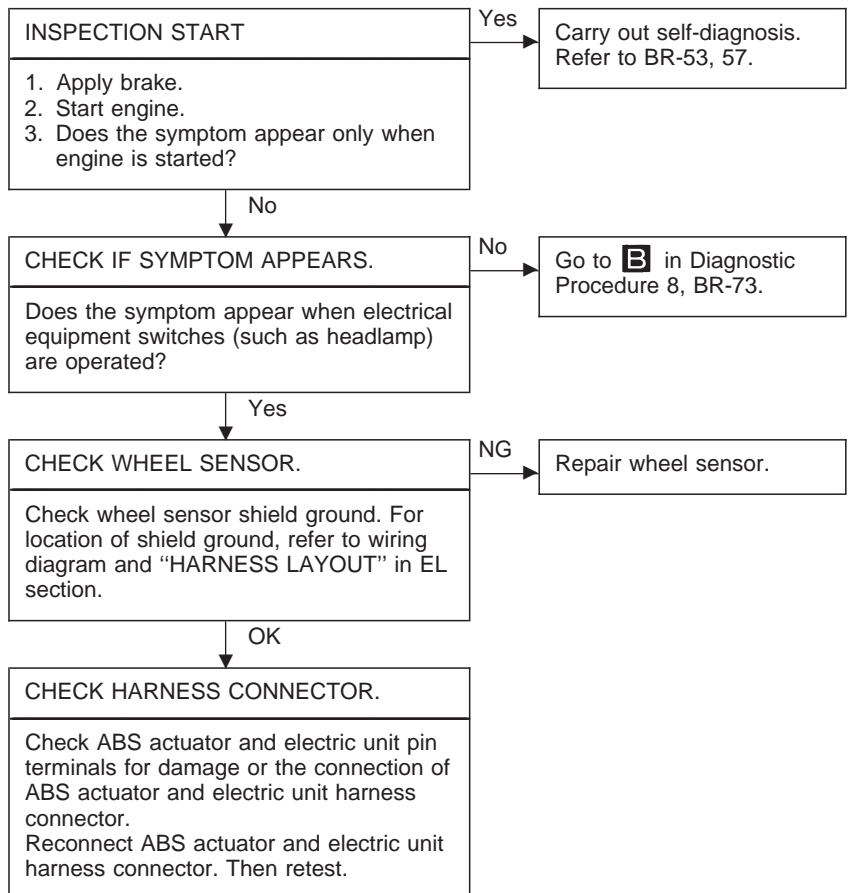

# TROUBLE DIAGNOSES FOR SYMPTOMS

## Diagnostic Procedure 11 (Pedal vibration and noise) (Cont'd)

Note: ABS may operate and cause vibration under any of the following conditions.

- Applying brake gradually when shifting or operating clutch.
- Low friction (slippery) road.
- High speed cornering.
- Driving over bumps and pot holes.
- Engine speed is over 5,000 rpm with vehicle stopped.

## Diagnostic Procedure 12 (Warning lamp does not come on when ignition switch is turned ON.)

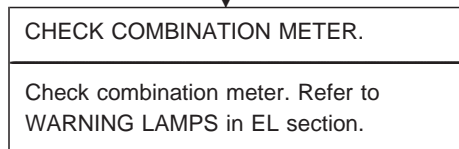
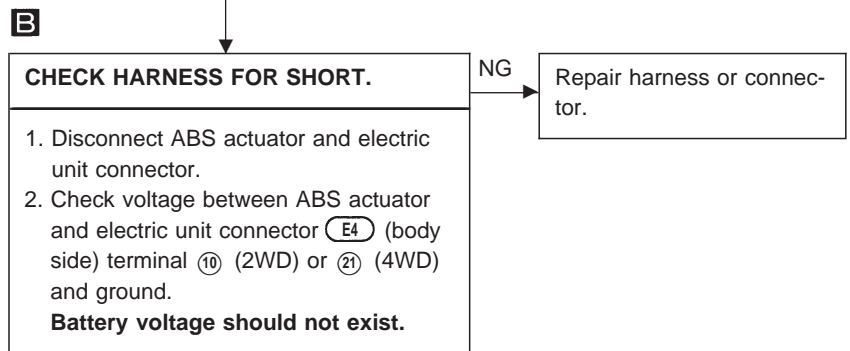
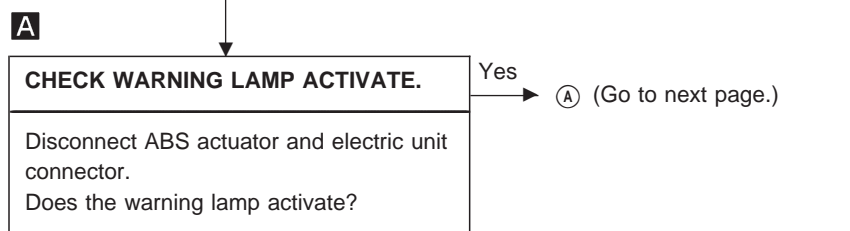
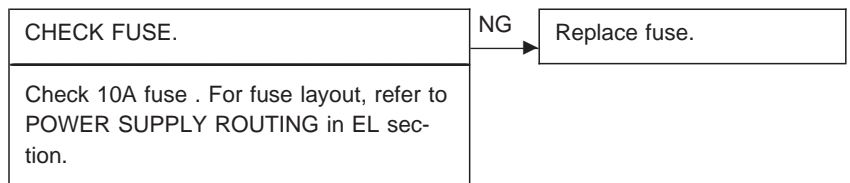
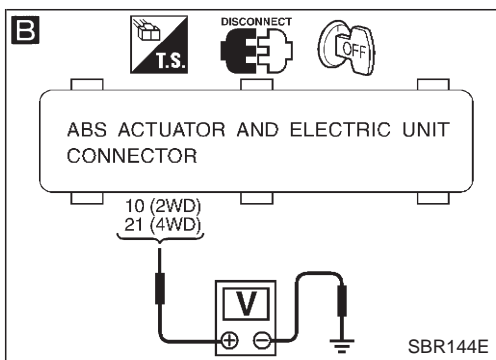
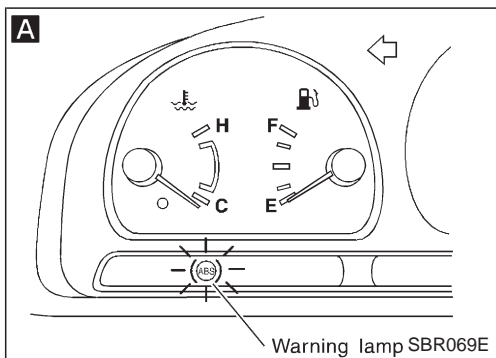
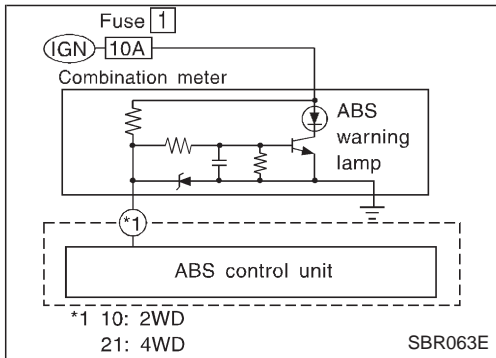

## TROUBLE DIAGNOSES FOR SYMPTOMS

### Diagnostic Procedure 12 (Warning lamp does not come on when ignition switch is turned ON.) (Cont'd)

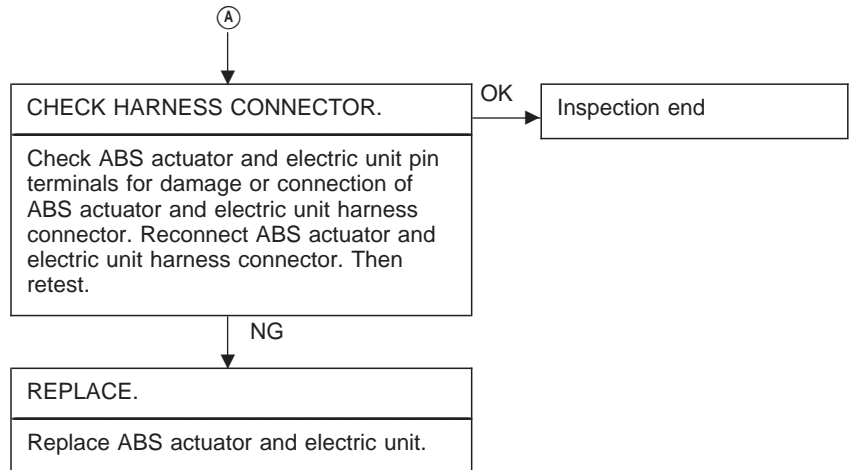

# TROUBLE DIAGNOSES FOR SYMPTOMS

## Diagnostic Procedure 13 (Warning lamp stays on when ignition switch is turned ON.)

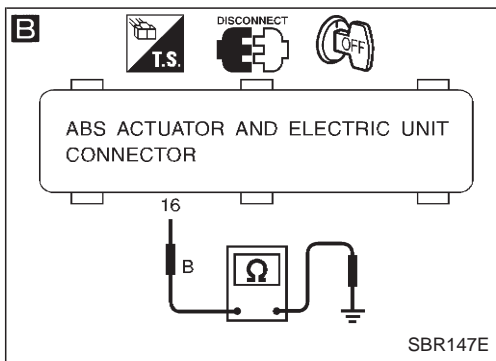
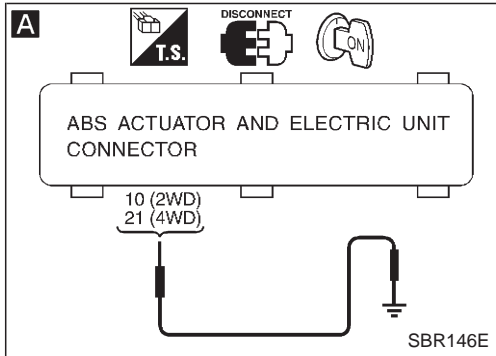
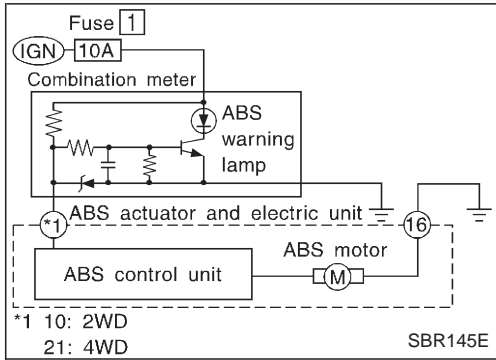

**A**

### CHECK WARNING LAMP.

1. Disconnect ABS actuator and electric unit connector.
2. Connect suitable wire between ABS actuator and electric unit connector (E4) (body side) terminal ⑩ (2WD) or ⑳ (4WD) and ground.

**Warning lamp should not activate.**

NG

Repair combination meter. Check the following.

- Harness connector (E4)
  - Harness for open or short between ABS actuator and electric unit and fuse
- If NG, repair harness or connector.

OK

### CHECK HARNESS CONNECTOR.

OK

Inspection end

Check ABS actuator and electric unit pin terminals for damage or the connection of ABS actuator and electric unit harness connector. Reconnect ABS actuator and electric unit harness connector. Then retest.

NG

**B**

### CHECK ABS MOTOR GROUND.

1. Turn ignition switch "OFF".
2. Disconnect ABS actuator and electric unit connector.
3. Check continuity between ABS actuator and electric unit connector (E4) (body side) ⑯ and ground.

**Continuity should exist.**

NG

Check the following.

- Harness connector (E4)
  - Harness for open or short between ABS actuator and electric unit and ground
- If NG, repair harness or connector.

OK

REPLACE.

Replace ABS actuator and electric unit.

# SERVICE DATA AND SPECIFICATIONS (SDS)

## General Specifications

### 2WD MODELS

| Applied model   | Without ABS                                   | With ABS |
|---|---|----------|
| Front brake   | CL28VD disc brake                             |          |
| Type  |   |          |
| Cylinder bore diameter    mm (in)                                   | 42.8 (1.685) x 2                              |          |
| Pad dimension                mm (in)<br>Length x width x thickness  | 146.6 x 48.5 x 10.0<br>(5.77 x 1.909 x 0.394) |          |
| Rotor outer diameter x thickness<br>mm (in)                         | 260 x 26<br>(10.24 x 1.02)                    |          |
| Rear brake  | LT26B drum brake                              |          |
| Type  |   |          |
| Wheel cylinder bore diameter<br>mm (in)                             | 23.81 (15/16)                                 |          |
| Lining dimension            mm (in)<br>Length x width x thickness   | 249.6 x 50 x 5.5<br>(9.83 x 1.97 x 0.217)     |          |
| Drum inner diameter        mm (in)                                  | 260 (10.24)                                   |          |
| Master cylinder bore diameter<br>mm (in)                            | 23.81 (15/16)                                 | 25.4 (1) |
| Control valve   | LSV   |          |
| Type  |   |          |
| Split point x reducing ratio<br>kPa (bar, kg/cm <sup>2</sup> , psi) | (Variable) x 0.15                             |          |
| Brake booster   | M195T   |          |
| Model   |   |          |
| Diaphragm diameter        mm (in)                                   | Primary: 205 (8.07)<br>Secondary: 180 (7.09)  |          |
| Recommended brake fluid   | DOT 3 or DOT 4*1                              |          |

\*1: Refer to MA section ("Fluids and Lubricants", "RECOMMENDED FLUIDS AND LUBRICANTS").



**SERVICE DATA AND SPECIFICATIONS (SDS)**  
**General Specifications (Cont'd)**

**4WD MODELS**

|   |  |
|---|--|
| Applied model   | All  |
| Front brake   |  |
| Type  | CL28VD disc brake                            |
| Cylinder bore diameter   mm (in)                                    | 42.8 (1.685) x 2                             |
| Pad dimension           mm (in)<br>Length x width x thickness       | 146.6 x 48.5 x 10<br>(5.77 x 1.909 x 0.39)   |
| Rotor outer diameter x thickness<br>mm (in)                         | 277 x 26 (10.91 x 1.02)                      |
| Rear brake  |  |
| Type  | LT30A drum brake                             |
| Wheel cylinder bore diameter<br>mm (in)                             | 22.22 (7/8)                                  |
| Lining dimension       mm (in)<br>Length x width x thickness        | 296.0 x 50.0 x 6.1 (11.65 x 1.969 x 0.240)   |
| Drum inner diameter    mm (in)                                      | 295 (11.61)                                  |
| Master cylinder bore diameter<br>mm (in)                            | 23.81 (15/16)                                |
| Control valve   |  |
| Type  | LSV  |
| Split point x reducing ratio<br>kPa (bar, kg/cm <sup>2</sup> , psi) | (Variable) x 0.15                            |
| Brake booster   |  |
| Model   | M215T  |
| Diaphragm diameter    mm (in)                                       | Primary: 230 (9.06)<br>Secondary: 205 (8.07) |
| Recommended brake fluid   | DOT 3 or DOT 4*1                             |

\*1: Refer to MA section ("Fluids and Lubricants", "RECOMMENDED FLUIDS AND LUBRICANTS").

# SERVICE DATA AND SPECIFICATIONS (SDS)

## Inspection and Adjustment

### DISC BRAKE

Unit: mm (in)

|                    |              |
|--------------------|--------------|
| Brake model        | CL28VD       |
| Pad wear limit     |              |
| Minimum thickness  | 2.0 (0.079)  |
| Rotor repair limit |              |
| Minimum thickness  | 24.0 (0.945) |

### DRUM BRAKE

Unit: mm (in)

|                        |               |               |
|------------------------|---------------|---------------|
| Brake model            | LT26B         | LT30A         |
| Lining wear limit      |               |               |
| Minimum thickness      | 1.5 (0.059)   |               |
| Drum repair limit      |               |               |
| Maximum inner diameter | 261.5 (10.30) | 296.5 (11.67) |
| Out-of-round limit     | 0.15 (0.0059) |               |

### BRAKE PEDAL

Unit: mm (in)

|  |                           |
|--|---------------------------|
| Free height "H"  |                           |
| LHD  | 209 - 219 (8.23 - 8.62)   |
| RHD  | 203 - 213 (7.99 - 8.39)   |
| Depressed height "D"<br>[under force of 490 N (50 kg, 110 lb) with engine running] | 120.0 (4.72)              |
| Clearance "C" between pedal stopper and threaded end of stop lamp switch           | 0.3 - 1.0 (0.012 - 0.039) |
| Pedal free play  |                           |
| At clevis  | 1.0 - 3.0 (0.039 - 0.118) |
| At pedal pad   | 4 - 12 (0.16 - 0.47)      |

\*: Measured from surface of melt sheet to pedal pad.

### PARKING BRAKE CONTROL

| Control type   |     | Stick lever | Center lever |
|--|-----|-------------|--------------|
| Lever stroke<br>[under force of 196 N<br>(20 kg, 44 lb)] | 2WD | 8 - 10      | —            |
|  | 4WD | 10 - 12     | 8 - 10       |
| Lever stroke when warning switch comes on                |     | 1           |              |